

**AN INVESTIGATION ON THE APPLICATION
OF THE METHOD OF PARTIAL IMAGES
TO A DYNAMIC PROBLEM**

John Francis Timony

LIBRARY
NAVAL POSTGRADUATE SCHOOL
MONTEREY, CALIF. 93940

NAVAL POSTGRADUATE SCHOOL

Monterey, California



THESIS

AN INVESTIGATION ON THE APPLICATION
OF THE METHOD OF PARTIAL IMAGES
TO A DYNAMIC PROBLEM

by

John Francis Timony

Thesis Advisor:

J.B. Knorr

June 1973

Approved for public release; distribution unlimited.

T155237

An Investigation on the Application
of the Method of Partial Images
to a Dynamic Problem

by

John Francis Timony
Ensign, United States Navy
B.S.E.E., United States Naval Academy, 1972

Submitted in partial fulfillment of the
requirements for the degree of

MASTER OF SCIENCE IN ELECTRICAL ENGINEERING

from the

NAVAL POSTGRADUATE SCHOOL
June 1973

ABSTRACT

The Method of Partial Images has been successfully applied to electrostatic problems involving conductors on a dielectric substrate. This same method is investigated for its adaptation to dynamic problems. A Green's Function is derived and applied to the problem of a wire dipole antenna on a dielectric substrate. The input admittance of the antenna is computed by the Method of Moments. Experimentally measured values of input admittance are compared with the theoretical values and the error is discussed.

TABLE OF CONTENTS

I.	INTRODUCTION -----	5
	A. THE USE OF IMAGE THEORY -----	5
	B. A DYNAMIC SOLUTION -----	6
II.	NATURE OF THE PROBLEM -----	7
	A. ON THE IMAGE COEFFICIENT METHOD -----	7
	B. SOLVING FOR THE GREEN'S FUNCTION -----	9
	C. PHASE CONSIDERATION -----	11
	D. THE USE OF Ψ_d -----	12
III.	THE IMPEDANCE MATRIX -----	13
	A. CALCULATION OF THE GREEN'S FUNCTION -----	13
	B. CALCULATION OF THE IMPEDANCE MATRIX -----	15
	1. Self-Impedance -----	17
	2. Mutual-Adjacent Impedance -----	18
	3. Mutual-Impedance -----	19
	C. PROGRAMMING -----	20
IV.	DATA EVALUATION -----	21
	A. EXPERIMENTAL PROCEDURE -----	21
V.	CONCLUSIONS -----	25
	A. EXPERIMENTAL DIFFERENCES -----	25
	B. PROBLEM IN THE GREEN'S FUNCTION -----	25
	APPENDIX A: DERIVATION OF THE IMPEDANCE FUNCTION ----	27
	APPENDIX B: DERIVATION OF THE GREEN'S FUNCTION -----	33
	APPENDIX C: FLOW CHART -----	36
	APPENDIX D: COMPUTER PROGRAM -----	37

BIBLIOGRAPHY -----	42
INITIAL DISTRIBUTION LIST -----	43
FORM DD 1473 -----	44

I. INTRODUCTION

If a monopole antenna is mounted on a perfectly conducting ground plane, it will reflect totally above the plane and will produce an image below the plane. This image will have an image current in the same direction as the monopole in order to satisfy boundary conditions at the ground plane. In essence, because of its image, the monopole will act as a dipole in a free-space. Hence, if the ground plane is removed, the image may be replaced by another physically real monopole thereby creating a dipole. In other words, conditions above the reflective plane remain unchanged if the plane is removed and a real object replaces the image.

A. THE USE OF IMAGE THEORY

With the monopole, the thickness of the ground plane is assumed to be negligible. This results in only one image. However, if the ground plane is a dielectric with finite thickness, total reflection no longer occurs. Instead, images are produced from partial reflection at the surface, reflection within the dielectric and transmission through the dielectric. These images are used in the "method of partial images" [1]. When the dielectric region is removed, these images may be considered real charges and are summed as an infinite series. However, a finite number of them give good results.

B. A DYNAMIC SOLUTION

The method of partial images has been successfully applied to static problems. The purpose of this research is to investigate its application in solving dynamic problems. A search for a Green's Function is conducted. Once found, it is utilized in an impedance equation. The equation generates an impedance matrix so that the "method of moments" can be used to solve for the current distribution or the input impedance of an antenna mounted on a dielectric substrate.

II. NATURE OF THE PROBLEM

Since the electrostatic problem has been solved, a method for solving the dynamic problem is sought using image theory. The dynamic situation is chosen to be a half-wave dipole antenna on a dielectric substrate of arbitrary thickness and relative permittivity (ϵ_r). A wire constitutes the antenna whose radius and length are variable.

A. ON THE IMAGE COEFFICIENT METHOD

Consider one small segment of the wire as an element of charge. Assume the charge to be a short distance from the dielectric. The charge element will have many lines

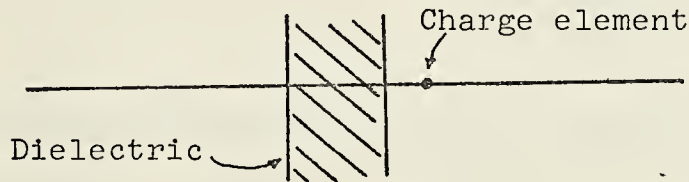

of flux in every radial direction. However, in considering a single line of flux, some of it penetrates the dielectric, while some of it is reflected at the interface. The amount reflected is proportional to the reflection coefficient (K). Similarly, the part penetrating the dielectric is proportional to $(1-K)$.

Naturally, many reflections and transmissions occur due to this single flux line. In turn, it produces many image points. The diagram serves to illustrate:

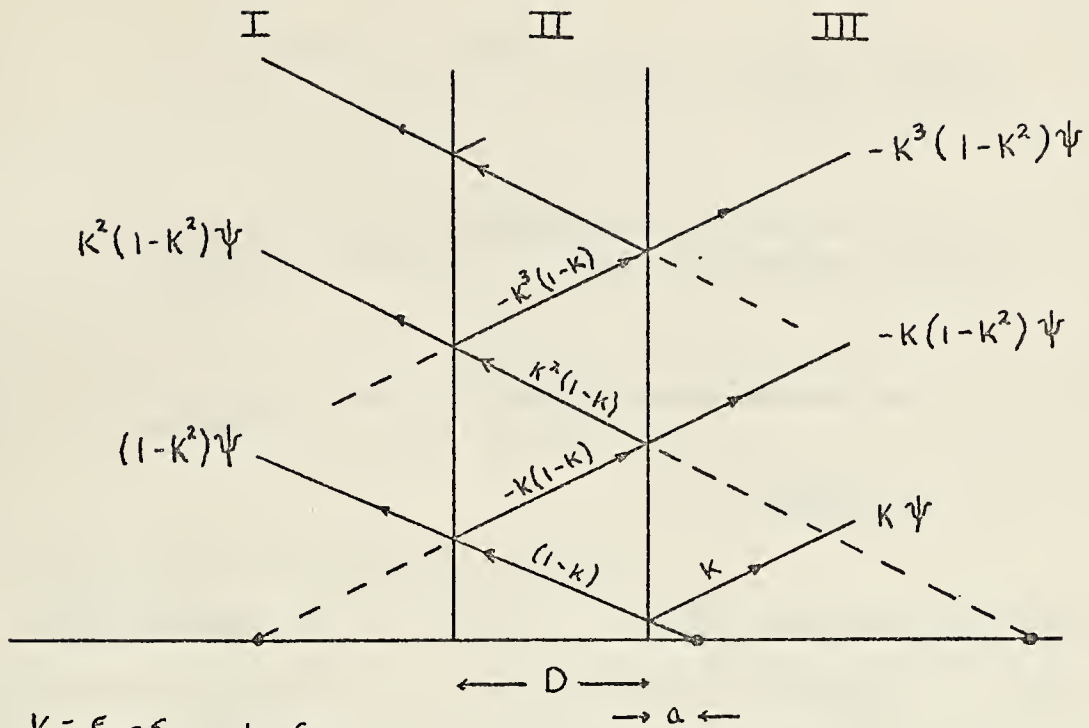

$$K = \frac{\epsilon_0 - \epsilon_r}{\epsilon_0 + \epsilon_r} = \frac{1 - \epsilon_r}{1 + \epsilon_r}$$

(Figure 1.)

Each of the three regions, I, II, III, may have different dielectric constants. However, in this case, regions I and III have $\epsilon_r = 1$ (free space). Region II has an arbitrary ϵ_r . In solving for the Green's Function, each region has a different image representation.

- (a). Image representation for left region - I.
- (b). Image representation for center region - II.
- (c). Image representation for right region - III.

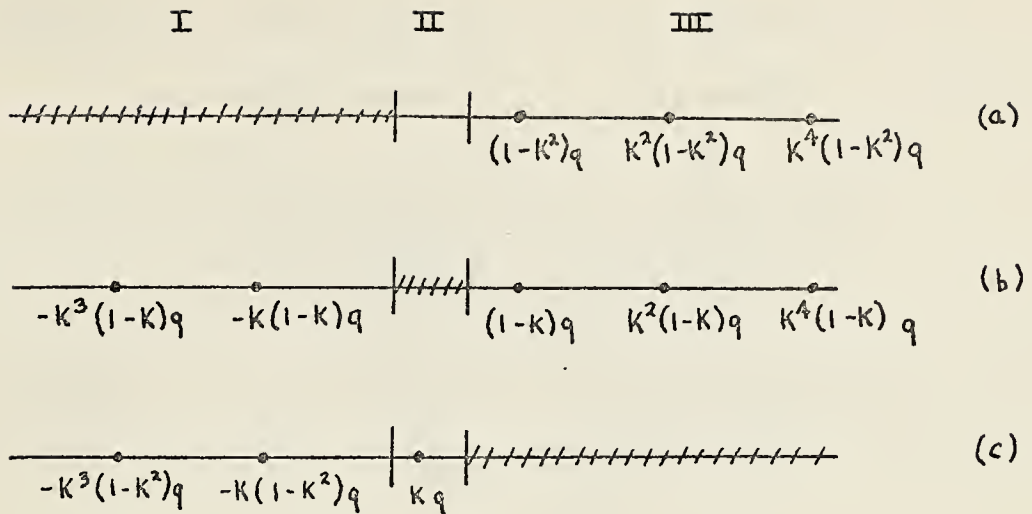

(Figure 2.)

B. SOLVING FOR THE GREEN'S FUNCTION

Specifically, in the problem at hand, the wire actually lies on the dielectric at the interface of regions II and III. Region II is the desired region with which to work because the accumulation of charge is assumed to be greater on the dielectric side of the wire than on the free space side. The image representation for this region appears as

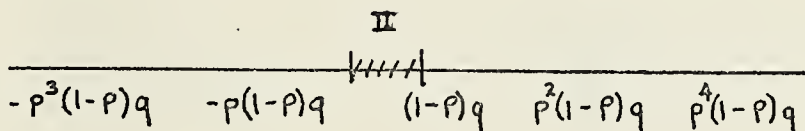

where the reflection coefficient is now $\rho = \frac{1-\epsilon_r}{1+\epsilon_r}$ in order to avoid confusion with the propagation constant (k).

Adding terms to simplify:

(a). For ψ_0 : $(1-\rho)$

$$(b). \text{ For } \psi_1: \quad \rho^2(1-\rho) - \rho(1-\rho) = (1-\rho)(\rho^2 - \rho) \\ = \rho(1-\rho)(\rho-1) = -\rho(1-\rho)^2$$

$$(c). \text{ For } \psi_2: \quad \rho^4(1-\rho) - \rho^3(1-\rho) = (1-\rho)(\rho^4 - \rho^3) \\ = \rho^3(1-\rho)(\rho-1) = -\rho^3(1-\rho)^2$$

$$(d). \text{ For } \psi_3: \quad \rho^6(1-\rho) - \rho^5(1-\rho) = (1-\rho)(\rho^6 - \rho^5) \\ = \rho^5(1-\rho)(\rho-1) = -\rho^5(1-\rho)^2$$

In terms of a summation, the Green's Function for the dielectric region is expressed

$$\psi_d = (1-\rho)\psi_0 - (1-\rho)^2 \sum \rho^{(2i-1)} \psi_i$$

where
$$\psi_i = \frac{\exp\left(-jk\sqrt{(x-x')^2 + (y-y')^2 + (z-2iD)^2}\right)}{4\pi\sqrt{(x-x')^2 + (y-y')^2 + (z-2iD)^2}}$$

$$\psi_0 = \frac{\exp\left(-jk\sqrt{(x-x')^2 + (y-y')^2}\right)}{4\pi\sqrt{(x-x')^2 + (y-y')^2}}$$

$$\rho = \frac{1-\epsilon_r}{1+\epsilon_r} \quad k = \frac{2\pi}{\lambda_d}$$

Yet, with a single wire, variation occurs in only the X-direction.

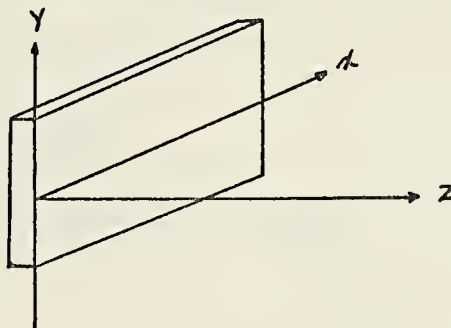

The dielectric Green's Function then becomes

$$\psi_d = (1-\rho)\psi_0 - (1-\rho)^2 \sum_{i=1}^{\infty} \rho^{(2i-1)} \psi_i$$

where

$$\psi_i = \frac{\exp\left(-jk\sqrt{(\kappa-\kappa')^2 + (2iD)^2}\right)}{4\pi\sqrt{(\kappa-\kappa')^2 + (2iD)^2}}$$

$$\psi_0 = \frac{\exp\left(-jk\sqrt{(\kappa-\kappa')^2}\right)}{4\pi\sqrt{(\kappa-\kappa')^2}}$$

C. PHASE CONSIDERATION

In formulating the Green's Function for the static problem, the phase of each image point need not be considered. However, in the dynamic problem, image point phase must be examined. With the charge element a distance "a" from the dielectric in Figure 1, each image point has a phase term associated with it. This means that ψ_d could not be expressed as a simple summation.

On the other hand, phase terms are eliminated if the charge element is adjacent to the dielectric. Since the wire is actually adjoined to the dielectric, every image point appears as though it were immersed in the dielectric region. For instance, consider image point "q₁" which

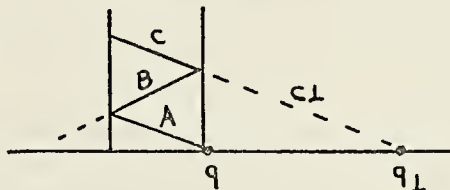

results from image path C1. This C1 comes from flux line A, which is reflected into B and then C. The image path length (C1) is equal to the addition of dielectric path lengths A and B through simple geometry. In other words, the image path "C1" appears to be in the dielectric medium due to A and B. Then image point "q₁" also appears to originate in the dielectric for the same reason. This is true for every image point. Hence, all image points appear to be in the same medium with equal phase. The Green's Function, then, retains its simple form.

D. THE USE OF ψ_d

The Green's Function (ψ_d) of this section was derived in a manner similar to Silvester's solution [1] using the method of partial images. Silvester, of course, solved a static problem. Yet, it seems logical to assume that his method should be applicable to a dynamic problem through the reasons stated.

The method of moments is used to find a numerical solution to the input impedance of the antenna. This method utilizes the Green's Function in solving for the impedance matrix.

III. THE IMPEDANCE MATRIX

In solving for the current distribution or the feed-point impedance of an antenna, the matrix approach in the method of moments is a good approximation. The key is to properly load the impedance matrix. Once this is accomplished, assumed values of voltage fill the voltage matrix and the problem is solved.

$$[I] = [Z]^{-1} [V]$$

The impedance matrix is obtained through the impedance equation. The equation is derived by Harrington [2] and the details are given in Appendix A. The Green's Function (ψ_d) from the previous section is employed in the equation.

$$Z(m,n) = j\omega\mu\Delta\bar{l}_n \cdot \Delta\bar{l}_m \psi(n,m) + \frac{1}{j\omega\epsilon} \left[\psi(\bar{n}, \bar{m}) - \psi(\bar{n}, \bar{m}) - \psi(\bar{n}, \bar{m}) + \psi(\bar{n}, \bar{m}) \right]$$

A. CALCULATION OF THE GREEN'S FUNCTION

In order to express the Green's Function in matrix form, ψ_d must be integrated along the wire. Holding the source point (n) fixed while the observation point (m) ranges over every segment generates the n^{th} column of the matrix. Then

moving the source point to the $(n+1)^{\text{st}}$ segment and, again, allowing the observation point (m) to roam along the wire generates the next column, etc. Finally, the $(m \times n)$ matrix is filled, where "m" is chosen numerically equal to "n".

In terms of equations:

$$\psi_{(n,m)} = \frac{1}{\Delta l_n} \int_{\Delta l_n} \psi_d dl$$

$$\psi_{(n,m)} = \frac{1}{\Delta l_n} \int \frac{(1-p) e^{-jk R_{om}} d\alpha'}{4\pi R_{om}} - \frac{1}{\Delta l_n} \int \frac{(1-p)^2}{4\pi} \sum_{i=1}^n p^{(2i-1)} \frac{e^{-jk R_{im}} d\alpha'}{R_{im}}$$

where

$$m=n \begin{cases} R_{om} = \sqrt{(\alpha_m - \alpha')^2 + a^2} \\ R_{im} = \sqrt{(2iD)^2} = 2iD \end{cases}$$

$$m \neq n \begin{cases} R_{om} = \sqrt{(\alpha_m - \alpha')^2} = (\alpha_m - \alpha') \approx (\alpha_m - \alpha_n) \\ R_{im} = \sqrt{(\alpha_m - \alpha')^2 + (2iD)^2} \approx \sqrt{(\alpha_m - \alpha_n)^2 + (2iD)^2} \end{cases}$$

There is a different Green's Function for each case.

The derivations are detailed in Appendix B while the results are shown here.

For case I. ($m=n$)

$$\psi(n,m) = \frac{(1-\rho)}{2\pi} \left[\frac{\ln\left(\frac{\Delta l_n}{a}\right)}{\Delta l_n} - \frac{jk}{2} \right] - \frac{(1-\rho)^2}{4\pi} \sum_{i=1}^n \rho^{(2i-1)} \frac{e^{-jk2iD}}{(2iD)}$$

For case II. ($m \neq n$)

$$\psi(n,m) = \frac{(1-\rho)}{4\pi} \frac{e^{-jk(\alpha_m - \alpha_n)}}{(\alpha_m - \alpha_n)}$$

$$- \frac{(1-\rho)^2}{4\pi} \sum_{i=1}^n \rho^{(2i-1)} \frac{e^{-jk\sqrt{(\alpha_m - \alpha_n)^2 + (2iD)^2}}}{\sqrt{(\alpha_m - \alpha_n)^2 + (2iD)^2}}$$

B. CALCULATION OF THE IMPEDANCE MATRIX

The impedance values are now found using the calculated Green's Functions in the impedance equation.

$$Z(m,n) = j\omega\mu \Delta l_n^2 \psi(n,m) + \frac{1}{j\omega\epsilon} \left[\psi(\bar{n}, \bar{m}) - \psi(\bar{n}, \bar{m}) - \psi(\bar{n}, \bar{m}) + \psi(\bar{n}, \bar{m}) \right]$$

Where $\Delta l_n^2 = \Delta \bar{l}_n \cdot \Delta \bar{l}_m$ since the length of each segment is chosen to be equal.

Three different situations arise in calculating elements of the impedance matrix. The first is the "self-impedance" term. Whenever the observation point and source point coincide, a self-impedance term is generated. These terms occupy the diagonal of the matrix and are all numerically equal.

The second situation is the "mutual-adjacent" term. These occur when the observation point is adjacent to the source point. Due to the fact that the distance between "m" and "n" is always the length of one segment (Δl_n), every mutual-adjacent term is equal.

The third situation happens when the observation and source points are one or more segments apart and are called "mutual impedance" terms. They complete the matrix and vary in magnitude.

1. Self-Impedance

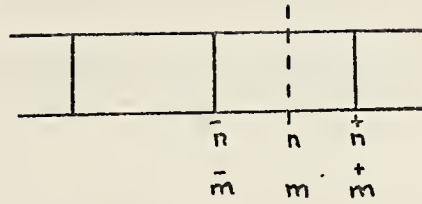

$$Z_{(n,n)} = j\omega\mu\Delta l_n^2 \left[\frac{(1-\rho)}{2\pi} \left[\frac{\ln\left(\frac{\Delta l_n}{a}\right)}{\Delta l_n} - \frac{jk}{2} \right] - \frac{(1-\rho)^2}{4\pi} \sum_{i=1}^n \rho^{(2i-1)} \frac{e^{-jk(2iD)}}{(2iD)} \right]$$

$$\frac{+2}{j\omega\epsilon_1} \left[\frac{(1-\rho)}{2\pi} \left[\frac{\ln\left(\frac{\Delta l_n}{a}\right)}{\Delta l_n} - \frac{jk}{2} \right] - \frac{(1-\rho)^2}{4\pi} \sum_{i=1}^n \rho^{(2i-1)} \frac{e^{-jk(2iD)}}{(2iD)} \right]$$

$$\frac{-2}{j\omega\epsilon_1} \left[\frac{(1-\rho)}{4\pi} \frac{e^{-jk\Delta l_n}}{\Delta l_n} - \frac{(1-\rho)^2}{4\pi} \sum_{i=1}^n \rho^{(2i-1)} \frac{e^{-jk\sqrt{(\Delta l_n)^2 + (2iD)^2}}}{\sqrt{(\Delta l_n)^2 + (2iD)^2}} \right]$$

2. Mutual-Adjacent Impedance

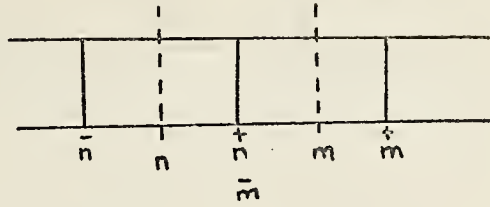

$$Z(m,n) = j\omega\mu\Delta l_n^2 \left[\frac{(1-p)}{4\pi} \frac{e^{-jk\Delta l_n}}{\Delta l_n} - \frac{(1-p)^2}{4\pi} \sum_{i=1}^n p^{(2i-1)} \frac{e^{-jk\sqrt{(\Delta l_n)^2 + (2iD)^2}}}{\sqrt{(\Delta l_n)^2 + (2iD)^2}} \right]$$

$$+ 2 \left[\frac{(1-p)}{4\pi} \frac{e^{-jk\Delta l_n}}{\Delta l_n} - \frac{(1-p)^2}{4\pi} \sum_{i=1}^n p^{(2i-1)} \frac{e^{-jk\sqrt{(\Delta l_n)^2 + (2iD)^2}}}{\sqrt{(\Delta l_n)^2 + (2iD)^2}} \right]$$

$$- \frac{1}{j\omega\epsilon_1} \left[\frac{(1-p)}{4\pi} \frac{e^{-jk2\Delta l_n}}{2\Delta l_n} - \frac{(1-p)^2}{4\pi} \sum_{i=1}^n p^{(2i-1)} \frac{e^{-jk\sqrt{(2\Delta l_n)^2 + (2iD)^2}}}{\sqrt{(2\Delta l_n)^2 + (2iD)^2}} \right]$$

$$- \frac{1}{j\omega\epsilon_1} \left[\frac{(1-p)}{2\pi} \left[\frac{\ln\left(\frac{\Delta l_n}{a}\right)}{\Delta l_n} - \frac{jk}{2} \right] - \frac{(1-p)^2}{4\pi} \sum_{i=1}^n p^{(2i-1)} \frac{e^{-jk(2iD)}}{(2iD)} \right]$$

3. Mutual Impedance

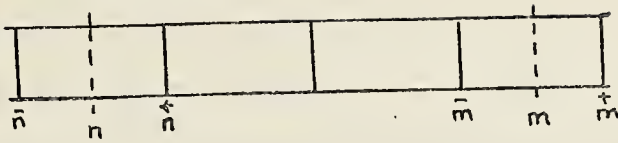

$$L = |m - n|$$

$$L_p = |m - n| + 1$$

$$L_m = |m - n| - 1$$

$$Z_{(m,n)} = j\omega\mu\Delta l_n^2 \left[\frac{(1-p)}{4\pi} \frac{e^{-jkL\Delta l_n}}{L\Delta l_n} - \frac{(1-p)^2}{4\pi} \sum_{i=1}^n p^{(2i-1)} \frac{e^{-jk\sqrt{(L\Delta l_n)^2 + (2iD)^2}}}{\sqrt{(L\Delta l_n)^2 + (2iD)^2}} \right]$$

$$\frac{+2}{j\omega\epsilon_1} \left[\frac{(1-p)}{4\pi} \frac{e^{-jkL\Delta l_n}}{L\Delta l_n} - \frac{(1-p)^2}{4\pi} \sum_{i=1}^n p^{(2i-1)} \frac{e^{-jk\sqrt{(L\Delta l_n)^2 + (2iD)^2}}}{\sqrt{(L\Delta l_n)^2 + (2iD)^2}} \right]$$

$$\frac{-1}{j\omega\epsilon_1} \left[\frac{(1-p)}{4\pi} \frac{e^{-jk(LP\Delta l_n)}}{(LP\Delta l_n)} - \frac{(1-p)^2}{4\pi} \sum_{i=1}^n p^{(2i-1)} \frac{e^{-jk\sqrt{(LP\Delta l_n)^2 + (2iD)^2}}}{\sqrt{(LP\Delta l_n)^2 + (2iD)^2}} \right]$$

$$\frac{-1}{j\omega\epsilon_1} \left[\frac{(1-p)}{4\pi} \frac{e^{-jk(LM\Delta l_n)}}{(LM\Delta l_n)} - \frac{(1-p)^2}{4\pi} \sum_{i=1}^n p^{(2i-1)} \frac{e^{-jk\sqrt{(LM\Delta l_n)^2 + (2iD)^2}}}{\sqrt{(LM\Delta l_n)^2 + (2iD)^2}} \right]$$

C. PROGRAMMING

The impedance equations of the previous section are programmed for computer usage. Of course, similarities exist throughout the equations making the programming easier.

Once the proper parameters and constants are selected, the impedance matrix is filled and then inverted. The values of voltage in the voltage matrix are chosen to be zero everywhere except at the feedpoint, where the source is one volt.

$$[Z]^{-1} [V] = [I]$$

The resulting matrix $[I]$ will be the current distribution on the wire. The middle value of $[I]$, the feedpoint value, is the feedpoint admittance since the source was one volt. The computer program is written to solve for various values of feedpoint, or input, admittances.

IV. DATA EVALUATION

After programming the equations, meaningful data is sought for analysis. Several parameters are available: the radius, the length, the dielectric constant, the thickness, and the frequency. In order to evaluate the validity of the equations, a comparison is made against Harrington's solutions.¹ Hence, the dielectric constant in Region II is chosen to be $\epsilon_r=1$. The length is equal to half of a free space wavelength at $f = 3$ GHz. The length-to-diameter ratio, $L/2a$, is set at 74.2, while the frequency is varied.

The results are plotted and compare favorably to Harrington's graphs. Figures 3 and 4 show conductance and susceptance, respectively, versus the length-to-wavelength ratios. It was found that at least a forty-one by forty-one matrix was necessary to achieve accuracy.

A. EXPERIMENTAL PROCEDURE

Experimentally, a thin copper strip was attached to a one-eighth inch thick dielectric substrate with $\epsilon_r=16$. The dielectric was mounted perpendicular onto the ground plane so that the thin strip would be fed as a quarter-wave monopole vice a half-wave dipole. The antenna was driven

¹Harrington, R.F., Field Computation by Moment Methods, p. 72, The MacMillan Company, 1968.

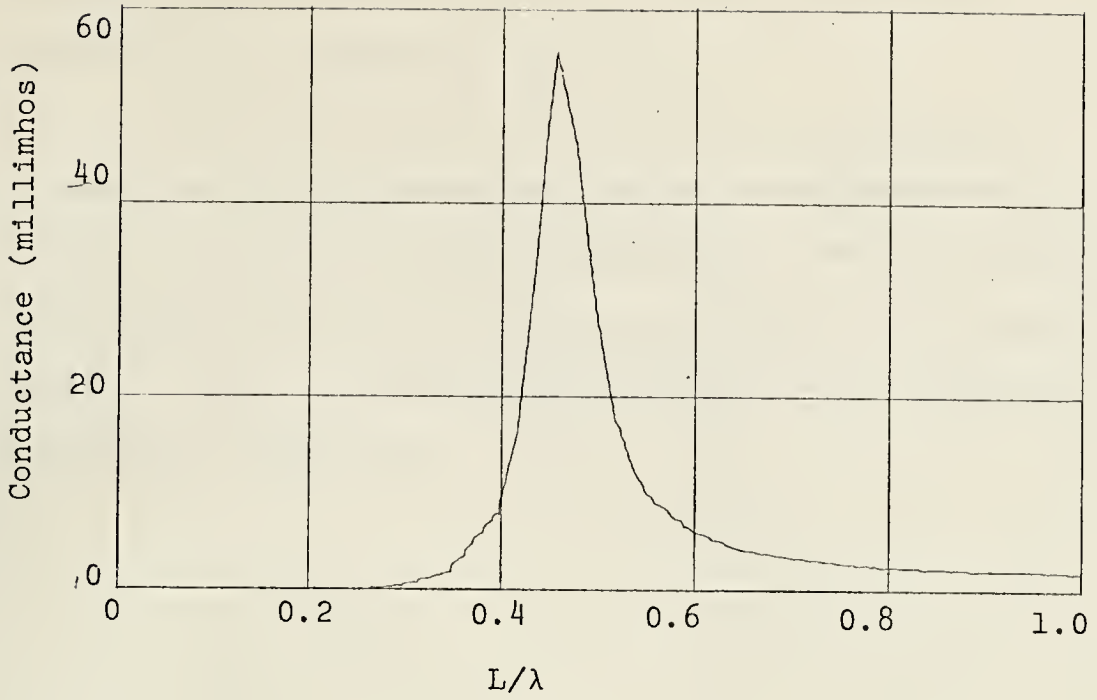

(Figure 3.)

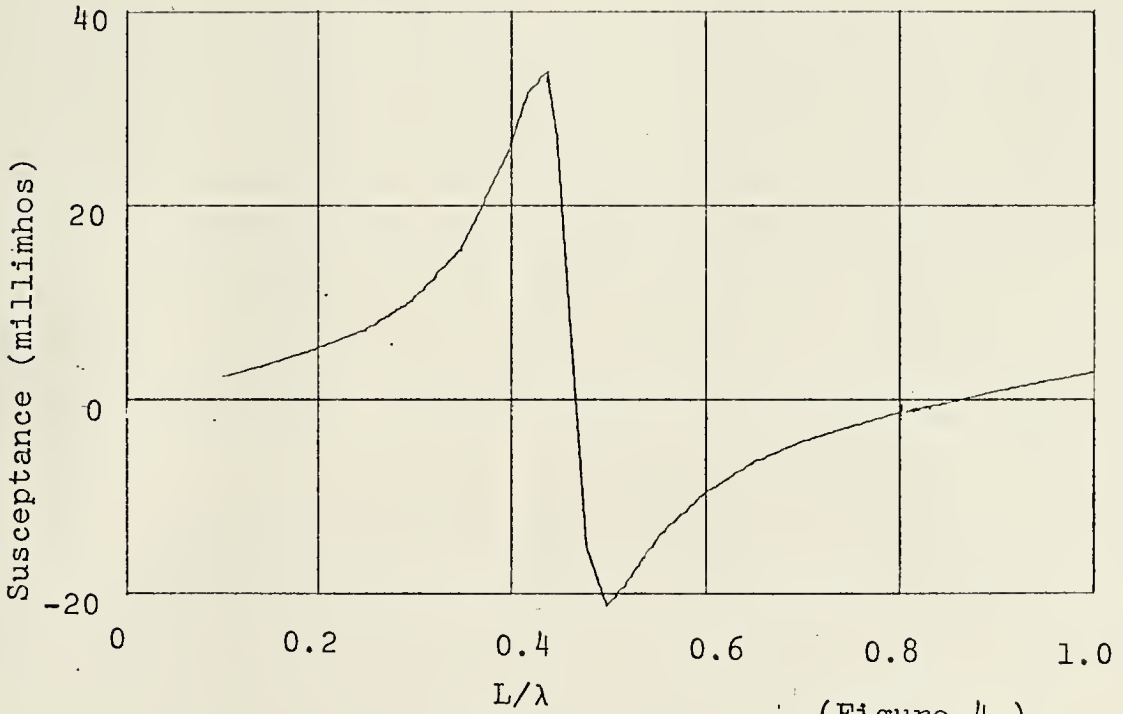

(Figure 4.)

Input Admittance of the Dipole

through 50 ohm miniature coax and input impedance was measured with a network analyzer.

The experimental values of input conductance and susceptance are plotted along with values calculated using the impedance equations. Obviously, Figures 5 and 6 illustrate a significant difference between experimental and calculated results. There is an amplitude variation and a difference in resonant frequencies.

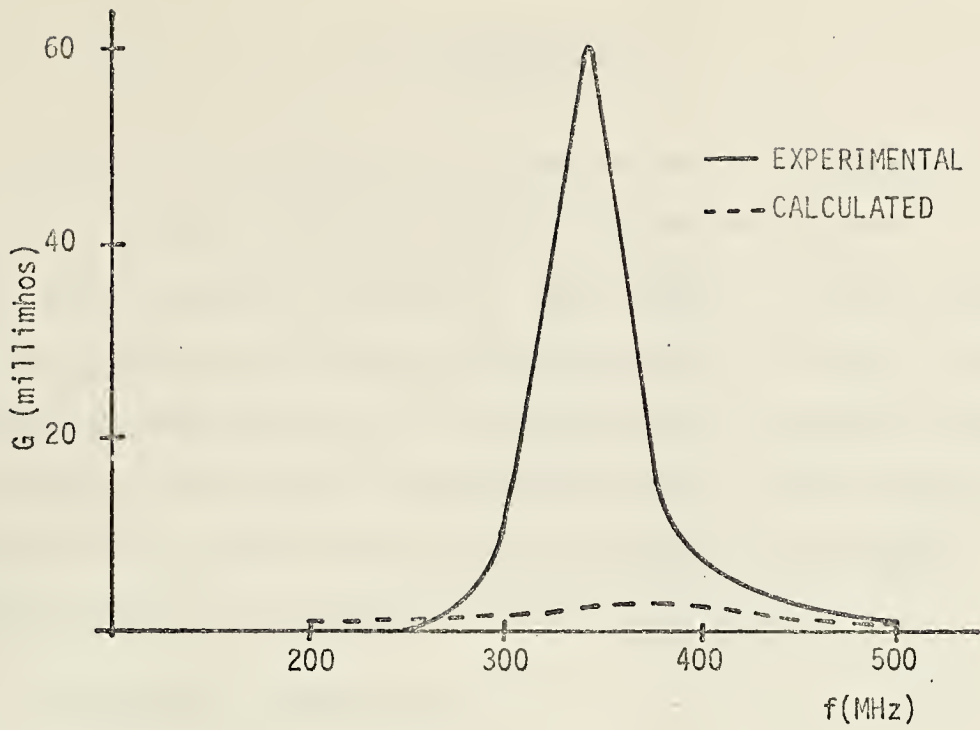

(Figure 5.)

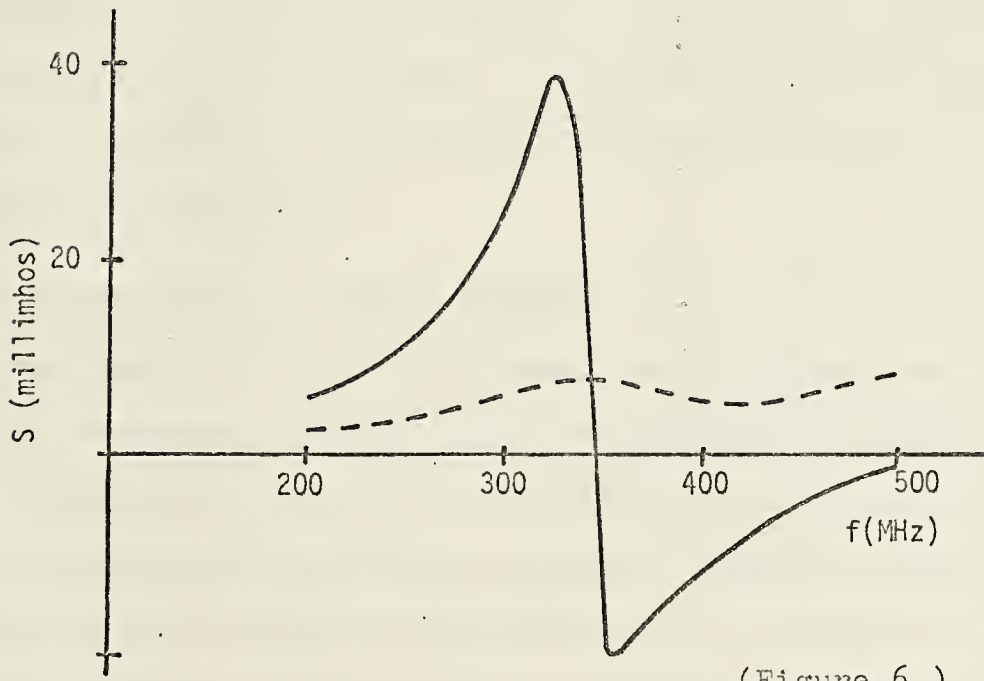

(Figure 6.)

V. CONCLUSIONS

From the free-space curves which match Harrington's curves, it seems that the Green's Function and the impedance equations are valid. Of course, in this instance, $\epsilon_r=1$ so that the reflection coefficient (ρ) is zero and every term containing (ρ) is eliminated. The part remaining is simply a free-space Green's Function. Hence, the solution is valid for a half-wave dipole antenna in free-space. Unfortunately, the same is not true when $\epsilon_r > 1$.

A. EXPERIMENTAL DIFFERENCES

Aside from the normal attenuation losses of experimental measurements, it seems the only other inaccuracy would come from the adhesive used to attach the copper strip to the dielectric. This would influence the effective dielectric constant (ϵ_{EFF}) and, perhaps, the amplitude of the admittance. Therefore, the emphasis is switched to the calculation procedures.

B. PROBLEM IN THE GREEN'S FUNCTION

The manner in which the Green's Function was chosen allows some error to exist. The accumulation of charge was assumed to be greater on the dielectric side of the wire rather than the free-space side. Because of this, Region II was selected in accordance with the method of partial images to solve for the necessary Green's Function. In the process, the propagation constant is dependent on

the relative permittivity of the dielectric.

$$k = \frac{2\pi}{\lambda_d} = \frac{2\pi}{\lambda\sqrt{\epsilon_r}}$$

However, from the physical standpoint, as the limit of the dielectric thickness approaches zero, the Green's Function should reduce to a free-space solution. Yet, ψ_d from section II-B will never reduce to a free-space function due to the dependence of the propagation constant on ϵ_r . This suggests the use of both a free-space propagation constant and a dielectric propagation constant. But there does not seem to be any apparent method in combining the two propagation constants with a Green's Function for Region II.

Further investigation led to a Green's Function for Region III which incorporated both propagation constants. It reduces to the free-space function as zero dielectric thickness is approached. However, the solution leads to negative conductance.

Finally, since the method of partial images can produce valid solutions for static and free-space dynamic problems, it would seem that with some additional changes this same method should solve all dynamic problems. Unfortunately, the final answer lies beyond the research efforts of this paper. The method of partial images, however, warrants the need for further investigation.

APPENDIX A

DERIVATION OF THE IMPEDANCE EQUATION

The impedance equation is developed in a manner similar to Harrington's derivation. Formulating the problem:

$$\bar{E}^s = -j\omega \bar{A} - \bar{\nabla} \Phi \quad (A-1)$$

$$A = \mu \oiint \bar{J}_s \frac{e^{-jkR}}{4\pi R} dS \quad (A-2)$$

$$\Phi = \frac{1}{\epsilon} \oiint \sigma_s \frac{e^{-jkR}}{4\pi R} dS \quad (A-3)$$

$$\sigma_s = \frac{-1}{j\omega} \bar{\nabla}_s \cdot \bar{J}_s \quad (A-4)$$

$$\bar{n} \times \bar{E}^s = -\bar{n} \times \bar{E}^i \quad \text{on } S \quad (A-5)$$

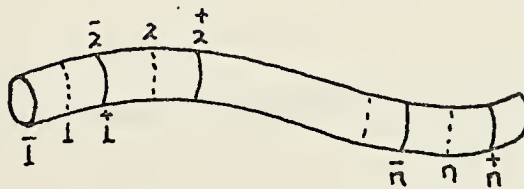

(Figure A-1)

The wire is broken into many segments subject to the following conditions:

- (1) Current flow is assumed to be along the wire axis.
- (2) To the axial component of \bar{E} at the surface, apply boundary condition (A-5).

With these assumptions, equations (A-1) through (A-4) become

$$-E_{\ell}^i = -j\omega \bar{A}_{\ell} - \frac{\partial \Phi}{\partial \ell} \quad \text{on } S \quad (\text{A-6})$$

$$\bar{A} = \mu \int_{\text{AXIS}} I(\ell) \frac{e^{-jkR}}{4\pi R} d\ell \quad (\text{A-7})$$

$$\Phi = \frac{1}{\epsilon} \int_{\text{AXIS}} \sigma(\ell) \frac{e^{-jkR}}{4\pi R} d\ell \quad (\text{A-8})$$

$$\sigma = \frac{-1}{j\omega} \frac{dI}{d\ell} \quad (\text{A-9})$$

where " ℓ " is the "length variable" along the axis of the wire.

Figure A-1 illustrates the division of the wire into "n" segments. According to the notation, any n^{th} segment starts at \bar{n} , is centered at n , and terminates at \bar{n}^+ . The distance between any \bar{n} and \bar{n}^+ is denoted by Δl_n , the length of the segment. Summing integrals over many small segments of Δl_n approximates an integral over the entire length. Equations (A-6) through (A-9) are then further approximated

$$-E_{\rho}^i(m) \approx j\omega A_{\rho}(m) - \frac{\Phi(\bar{n}^+) - \Phi(\bar{n})}{\Delta l_m} \quad (\text{A-10})$$

$$\bar{A}(m) \approx \mu \sum_n I(n) \frac{\Delta \bar{l}_n}{\Delta l_n} \int_{\Delta l_n} \frac{e^{-jkR}}{4\pi R} dl \quad (\text{A-11})$$

$$\Phi(\bar{n}^+) \approx \frac{1}{\epsilon} \sum_n \sigma(\bar{n}^+) \int_{\Delta l_n^+} \frac{e^{-jkR}}{4\pi R} dl \quad (\text{A-12})$$

$$\sigma(\bar{n}^+) \approx -\frac{1}{j\omega} \frac{I(n+1) - I(n)}{\Delta l_n^+} \quad (\text{A-13})$$

Similarly

$$\sigma(\bar{n}) \approx \frac{-1}{j\omega} \frac{I(n) - I(n-1)}{\Delta l_{\bar{n}}} \quad (\text{A-14})$$

substituting equation (A-13) into (A-12), and equation (A-14) into an equation similar to (A-12) for $\bar{\Phi}(\bar{m})$,

$$\bar{\Phi}(\bar{m}^+) = -\frac{1}{j\omega\epsilon} \sum_n \frac{I(n+1) - I(n)}{\Delta l_n^+} \int_{\Delta l_n^+} \frac{e^{-jkR}}{4\pi R} dl \quad (\text{A-15})$$

$$\bar{\Phi}(\bar{m}) = -\frac{1}{j\omega\epsilon} \sum_n \frac{I(n) - I(n-1)}{\Delta l_{\bar{n}}} \int_{\Delta l_{\bar{n}}} \frac{e^{-jkR}}{4\pi R} dl \quad (\text{A-16})$$

it is often convenient to express the integral parts of the above equations in the form of Green's Functions.

$$\psi(n, m) = \frac{1}{\Delta l_n} \int_{\Delta l_n} \frac{e^{-jkR_m}}{4\pi R_m} dl$$

Where R_m = the distance from the midpoint of the m^{th} segment to the integration point on the n^{th} segment.

Using this definition, equations (A-11), (A-15) and (A-16) become

$$\bar{A}(m) = \mu \sum_n I(n) \Delta \bar{l}_n \psi(n, m) \quad (\text{A-17})$$

$$\Phi(\hat{m}) = \frac{-1}{j\omega\epsilon} \sum_n \left[I(n+1) \Psi(\hat{n}, \hat{m}) - I(n) \Psi(\hat{n}, \hat{m}) \right] \quad (A-18)$$

$$\Phi(\bar{m}) = \frac{1}{j\omega\epsilon} \sum_n \left[I(n) \Psi(\bar{n}, \bar{m}) - I(n-1) \Psi(\bar{n}, \bar{m}) \right] \quad (A-19)$$

Now substituting equations (A-17), (A-18) and (A-19) into equation (A-10) and noting that $A_{\ell}(m) = \bar{A}(m) \cdot \frac{\Delta \bar{l}_m}{\Delta l_m}$

$$-E_{\ell}^i(m) = -\frac{j\omega\mu}{\Delta l_m} \sum_n I(n) \Delta \bar{l}_n \cdot \Delta \bar{l}_m \Psi(n, m)$$

$$\frac{-1}{\Delta l_m} \left\{ \begin{aligned} & -\frac{1}{j\omega\epsilon} \left[\sum_n I(n+1) \Psi(\hat{n}, \hat{m}) - I(n) \Psi(\hat{n}, \hat{m}) \right] \\ & + \frac{1}{j\omega\epsilon} \left[\sum_n I(n) \Psi(\bar{n}, \bar{m}) - I(n-1) \Psi(\bar{n}, \bar{m}) \right] \end{aligned} \right\} \quad (A-20)$$

Two further approximations are made

$$I(n+1) \Psi(\hat{n}, \hat{m}) \approx I(n) \Psi(\bar{n}, \hat{m}) \quad (A-21)$$

and

$$I(n-1) \Psi(\bar{n}, \bar{m}) \approx I(n) \Psi(\hat{n}, \bar{m}) \quad (A-22)$$

With these two substituted, equation (A-20) is written as

$$E_{\ell}^i(m) \Delta l_m = j\omega\mu \sum_n I(n) \Delta \bar{l}_n \cdot \Delta \bar{l}_m \Psi(n, m)$$

$$+ \frac{1}{j\omega\epsilon} \left\{ \sum_n I(n) \left[\Psi(\hat{n}, \hat{m}) - \Psi(\bar{n}, \hat{m}) - \Psi(\hat{n}, \bar{m}) + \Psi(\bar{n}, \bar{m}) \right] \right\} \quad (A-23)$$

or

$$E_{\rho}^i(m) \Delta l_m = \sum_n Z(m,n) I(n)$$

where

$$Z(m,n) = j\omega\mu \Delta \bar{l}_n \cdot \Delta \bar{l}_m \psi(n,m) + \frac{1}{j\omega\epsilon} \left[\psi(n,m^+) - \psi(\bar{n}, \bar{m}^+) - \psi(n^+, \bar{m}) + \psi(\bar{n}, \bar{m}) \right] \quad (A-24)$$

Equation (A-24) is the impedance equation which applies for the case of ($m=n$) self impedance, as well as for ($m \neq n$) mutual impedance.

Since "m" roams along all "n" segments of the wire, there is a set of "n" linear equations. In matrix form:

$$\begin{bmatrix} \bar{E}_{(1)}^i \cdot \Delta \bar{l}_1 \\ \bar{E}_{(2)}^i \cdot \Delta \bar{l}_2 \\ \circ \\ \circ \\ \circ \\ \bar{E}_{(n)}^i \cdot \Delta \bar{l}_n \end{bmatrix} = \begin{bmatrix} Z_{11} & Z_{12} & \circ & \circ & \circ & Z_{1n} \\ Z_{21} & & & & & \\ \circ & & & & & \\ \circ & & & & & \\ \circ & & & & & \\ Z_{n1} & Z_{n2} & \circ & \circ & \circ & Z_{nn} \end{bmatrix} \begin{bmatrix} I_{(1)} \\ I_{(2)} \\ \circ \\ \circ \\ \circ \\ I_{(n)} \end{bmatrix}$$

or

$$[V] = [Z] [I]$$

If [V] and [Z] are known, the current distribution may be found,

$$[I] = [Z]^{-1} [V]$$

as well as the feedpoint impedance.

APPENDIX B

DERIVATION OF THE GREEN'S FUNCTION

There is a distinct Green's Function for each case: when the observation point coincides with the source point ($m=n$); and when the observation point and source do not coincide ($m \neq n$).

Case I. ($m=n$)

$$\Psi(n,m) = \frac{1}{\Delta l_n} \int_{\Delta l_n} \frac{(1-\rho)}{4\pi} \frac{e^{-jk\sqrt{(x_m-x')^2+a^2}}}{\sqrt{(x_m-x')^2+a^2}} dx'$$

$$- \frac{1}{\Delta l_n} \int_{\Delta l_n} \frac{(1-\rho)^2}{4\pi} \sum_{i=1}^n \rho^{(2i-1)} \frac{e^{-jk(2iD)}}{(2iD)} dx'$$

a. The first term must be integrated over one segment



Using a Maclaurin series expansion on the first term:

$$\frac{(1-\rho)}{4\pi \Delta l_n} \int_{\Delta l_n} \frac{e^{-jk\sqrt{(x_m-x')^2+a^2}}}{\sqrt{(x_m-x')^2+a^2}} dx' = \frac{(1-\rho)}{4\pi \Delta l_n} \int_{\Delta l_n} \left[\frac{1}{\sqrt{(x_m-x')^2+a^2}} \right.$$

$$\left. -jk - \frac{k^2}{2} \sqrt{(x_m-x')^2+a^2} + \dots \right] dx'$$

since the first two terms of this Maclaurin expansion give reasonably good results,

$$= \frac{(1-\rho)}{4\pi\Delta l_n} \left[2 \ln(r_m - r') + \sqrt{(r_m - r')^2 + a^2} \right]_{\frac{\Delta l_n}{2}}^{\frac{\Delta l_n}{2}} - 2jk r' \left[\right]_{\frac{\Delta l_n}{2}}^{\frac{\Delta l_n}{2}}$$

assuming $\Delta l_n \approx 10a$

$$= \frac{(1-\rho)}{4\pi\Delta l_n} \left[2 \ln\left(\frac{\Delta l_n}{a}\right) - jk\Delta l_n \right] = \frac{(1-\rho)}{2\pi} \left[\frac{\ln\left(\frac{\Delta l_n}{a}\right)}{\Delta l_n} - \frac{jk}{2} \right]$$

b. Integration is now performed on the second term of the Green's Function.

$$\begin{aligned} & -\frac{1}{\Delta l_n} \int_{\Delta l_n} \frac{(1-\rho)^2}{4\pi} \sum_{i=1}^n \rho^{(2i-1)} \frac{e^{-jk2iD}}{2iD} dx' \\ &= -\frac{(1-\rho)^2}{4\pi\Delta l_n} \sum_{i=1}^n \rho^{(2i-1)} \frac{e^{-jk2iD}}{2iD} \int_{\Delta l_n} dx' \\ &= -\frac{(1-\rho)^2}{4\pi} \sum_{i=1}^n \rho^{(2i-1)} \frac{e^{-jk2iD}}{2iD} \end{aligned}$$

Finally, the Green's Function for Case I, ($m=n$) is

$$\psi(n, m) = \frac{(1-\rho)}{2\pi} \left[\frac{\ln\left(\frac{\Delta l_n}{a}\right)}{\Delta l_n} - j\frac{k}{2} \right] - \frac{(1-\rho)^2}{4\pi} \sum_{i=1}^n \rho^{(2i-1)} \frac{e^{-jk2iD}}{2iD}$$

Case II. ($m \neq n$)

$$\psi(n, m) = \frac{1}{\Delta l_n} \int_{\Delta l_n} \frac{(1-\rho) e^{-jk(r_m - r_n)}}{4\pi(r_m - r_n)} dr' - \frac{1}{\Delta l_n} \int_{\Delta l_n} \frac{(1-\rho)^2}{4\pi} \sum_{i=1}^n \rho^{(2i-1)} \frac{e^{-jk\sqrt{(r_m - r_n)^2 + (2iD)^2}}}{\sqrt{(r_m - r_n)^2 + (2iD)^2}} da'$$

For the crudest approximation, assume that

$\sqrt{(r_m - r_n)^2 + (2iD)^2}$ remains constant over the integration.

Then, the Green's Function for ($m \neq n$) becomes

$$\psi(n, m) = \frac{(1-\rho)}{4\pi} \frac{e^{-jk(r_m - r_n)}}{(r_m - r_n)} - \frac{(1-\rho)^2}{4\pi} \sum_{i=1}^n \rho^{(2i-1)} \frac{e^{-jk\sqrt{(r_m - r_n)^2 + (2iD)^2}}}{\sqrt{(r_m - r_n)^2 + (2iD)^2}}$$

APPENDIX C. FLOW CHART

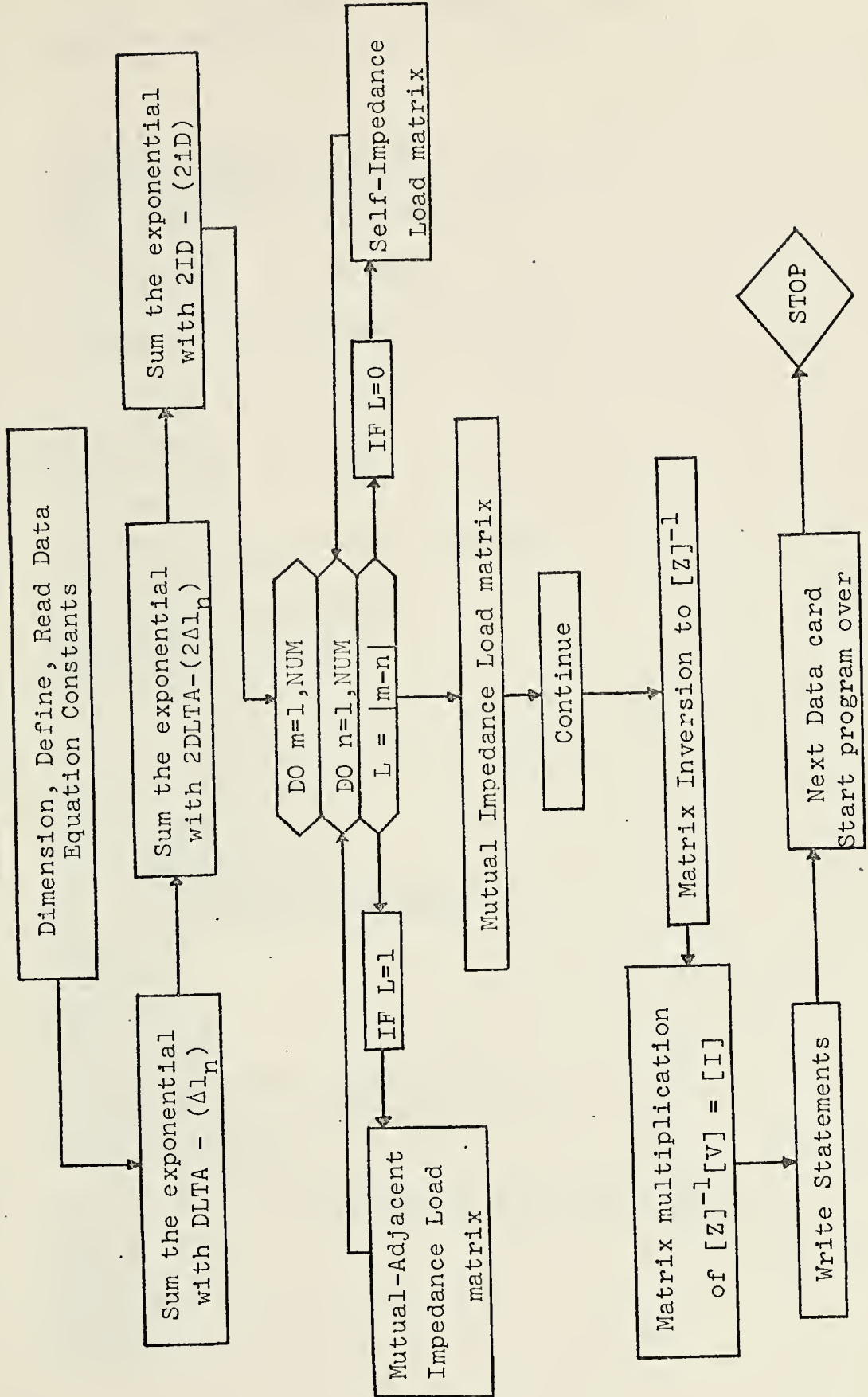

APPENDIX D. COMPUTER PROGRAM

COMPUTER APPLICATION ON THE METHOD
OF IMAGES USING REGION II

```

IMPLICIT REAL*4 (K)
IMPLICIT COMPLEX*8 (C,Z)
DIMENSION Z(41,41), ZMP(41), Y(41)
REAL*4 CAMPS(41)
REAL V(41)/20*0.0, 1.0, 20*0.0/
COMPLEX CABS

```

```

THE THICKNESS (D) IN METERS
D=0.003175

```

```

THE DIELECTRIC CONSTANT (ER)
ER=16.0

```

```

THE RADIUS (A) IN METERS
A=0.000500

```

```

20 READ(5, 30, END=260) DATA
30 FORMAT(F5.3)
NUM=41
MID=(NUM+1)/2

```

```

THE LENGTH OF THE WIRE IN METERS
ELNGTH=0.13493750

```

```

DLTA=ELNGTH/(FLOAT(NUM))
F=((3E08)*DATA)/ELNGTH
PI=3.14159
W=2.0*PI*F
U=PI*4.0*1.E-7
EO=1.0/(36.0*PI)*1.E-9

```

EQUATION CONSTANTS

```

RHC=(1.0-ER)/(1.0+ER)
B=C.0
K=W*SQRT(U*EO*ER)
A1=W*U*DLTA**2
A2=(1.0-RHO)/(2.0*PI)
A3=(1.0/DLTA)*ALOG(DLTA/A)
A4=1.0/(2.0*PI)*(1.0-RHO)**2
A5=2.0/(W*EO*ER)
A6=A2/2.0
A7=A4/2.0
A8=A5/2.0
A9=K/2.0
A10=DLTA**2
A11=4.0*D**2
AK1=K*DLTA
CD1=CEXP(CMPLX(B, -AK1))/DLTA
AK2=2.0*AK1
CD2=CEXP(CMPLX(B, -AK2))/(2.0*DLTA)
C1=CMPLX(B, A1)
C2=A3-CMPLX(B, A9)

```

SUMMATION OF THE EXPONENTIAL WITH DELTA (DLTA)

```

C3=CMPLX(B, B)
R2=0.0
DC 40 J=1, 10
J1=2.0*J-1
J2=J**2
R1=RHO**J1
R2=R2+R1

```



```

X1=SQRT(A10+A11*J2)
X2=K*X1
C4=CEXP(CMPLX(B,-X2))
C5=(R1*C4)/X1
C3=C3+C5
40 CONTINUE

```

```

C
C
C
C
SUMMATION OF THE EXPONENTIAL WITH 2*DELTA (2*DLTA)

```

```

C6=CMPLX(B,B)
R3=0.0
DO 50 I=1,10
I1=2.0*I-1
I2=I**2
R4=RHO**I1
R3=R3+R4
X3=SQRT(4.0*A10+A11*I2)
X4=K*X3
C8=CEXP(CMPLX(B,-X4))
C9=(R4*C8)/X3
C6=C6+C9
50 CONTINUE

```

```

C
C
C
C
SUMMATION OF THE EXPONENTIAL WITH 2*I*D

```

```

C20=CMPLX(B,B)
DC 60 I=1,10
I3=2.0*I-1
I4=I**2
R10=RHO**I3
X20=2.0*I*D
X21=K*X20
C21=CEXP(CMPLX(B,-X21))
C22=(R10*C21)/X20
C20=C20+C22
60 CONTINUE

```

```

C
C
C
C
CALCULATION OF THE IMPEDANCE MATRIX

```

```

DO 110 M=1,NUM
DC 100 N=1,NUM
L=IABS(M-N)
IF(L.EQ.0) GO TO 90
IF(L.EQ.1) GO TO 80

```

```

C
C
C
C
FOR MUTUAL IMPEDANCE

```

```

LP=L+1
LM=L-1
AK3=K*L*DLTA
CD3=CEXP(CMPLX(B,-AK3))/(L*DLTA)
AK4=K*LP*DLTA
CD4=CEXP(CMPLX(B,-AK4))/(LP*DLTA)
AK5=K*LM*DLTA
CD5=CEXP(CMPLX(B,-AK5))/(LM*DLTA)
C10=CMPLX(B,B)
C13=CMPLX(B,B)
C16=CMPLX(B,B)
R5=0.0
DC 70 J=1,10
J11=2.0*J-1
J22=J**2
R6=RHO**J11
R5=R5+R6
A12=(L*DLTA)**2
X5=SQRT(A12+A11*J22)
X6=K*X5
C11=CEXP(CMPLX(B,-X6))

```



```

C12=(R6*C11)/X5
C10=C10+C12
A13=(LP*DLTA)**2
X7=SQRT(A13+A11*J22)
X8=K*X7
C14=CEXP(CMPLX(B,-X8))
C15=(R6*C14)/X7
C13=C13+C15
A14=(LM*DLTA)**2
X9=SQRT(A14+A11*J22)
X10=K*X9
C17=CEXP(CMPLX(B,-X10))
C18=(R6*C17)/X9
C16=C16+C18
70 CCNTINUE
Z21=C1*(A6*CD3-A7*C10)
Z22=(CMPLX(B,-A5))*(A6*CD3-A7*C10)
Z23=(CMPLX(B,A8))*(A6*CD4-A7*C13)
Z24=(CMPLX(B,A8))*(A6*CD5-A7*C16)
Z(M,N)= Z21 + Z22 + Z23 + Z24
GO TO 100

```

```

FOR MUTUAL-ADJACENT IMPEDANCE

```

```

80 Z31=C1*(A6*CD1-A7*C3)
Z32=(CMPLX(B,-A5))*(A6*CD1-A7*C3)
Z33=(CMPLX(B,A8))*(A6*CD2-A7*C6)
Z34=(CMPLX(B,A8))*(A2*C2-A7*C20)
Z(M,N) = Z31+Z32+Z33+Z34
GO TO 100

```

```

FOR SELF IMPEDANCE

```

```

90 Z11=C1*(A2*C2-A7*C20)
Z12=(CMPLX(B,-A5))*(A2*C2-A7*C20)
Z13=(CMPLX(B,A5))*(A6*CD1-A7*C3)
Z(M,N) = Z11+Z12+Z13
100 CONTINUE
110 CCNTINUE

```

```

THE MATRIX INVERSION
CALL CMINI(NUM,Z,NUM,DETERM)

```

```

MATRIX MULTIPLICATION OF Z-INVERSE AND V

```

```

DO 130 I=1,NUM
ZMP(I)=(0.0,0.0)
DO 120 J=1,NUM
ZMP(I)=ZMP(I)+Z(I,J)*V(J)
120 CCNTINUE
130 CONTINUE
WRITE(6,140)
140 FORMAT('1')
WRITE(6,150)
150 FCRMAT(15(/))
WRITE(6,160) D,ER,A
160 FORMAT(10X,'THE THICKNESS D',15X,F12.8,/,10X,'THE ',
1'DIELECTRIC CONSTANT ER',4X,F12.8,/,10X,'THE RADIUS',
2'A',18X,F12.8,/)
WRITE(6,170) W
170 FCRMAT(//,10X,'THE RADIAN FREQUENCY W',10X,E13.7,/)
WRITE(6,180)
180 FCRMAT(10X,'THE COMPLEX CURRENT AT THE FEEDPOINT IN ',
3'AMPS',/)
WRITE(6,190) ZMP(MID)
190 FORMAT(42X,E11.5,3X,E11.5,3X)
DO 200 I=1,NUM
CAMPS(I)=CABS(ZMP(I))

```



```

200 CONTINUE
    WRITE(6,210)
210 FORMAT(//,10X,'THE MAGNITUDE OF THE CURRENT',/)
    WRITE(6,220) CAMPS(MID)
220 FORMAT(42X,E11.5)
    WRITE(6,230) DATA
230 FORMAT(//,10X,'FOR THE LENGTH/LAMDA RATIO ',5X,F6.4,/)
    WRITE(6,240) F
240 FORMAT(//,10X,'THE FREQUENCY F',16X,1PE10.4,/)

C
C
C    CARD PRINT OUT - DATA FOR DRAW SUBROUTINE
    WRITE(7,250) ZMP(MID)
250 FORMAT(E11.5)

C
    GO TO 20
260 CONTINUE
    STCP
    END

SUBROUTINE CMIN1 (N,A,NDIM,DETERM)

C
C
C    CMIN1 IS A SUBROUTINE WHICH WILL ACCEPT A SINGLE
C    PRECISION COMPLEX MATRIX AND RETURNS THE INVERSE
C    OF THE MATRIX IN ITS PLACE.
C
C    N      - THE ORDER OF THE MATRIX TO BE INVERTED
C    A      - COMPLEX SINGLE PRECISION INPUT MATRIX
C             (DESTROYED). THE INVERSE OF A IS
C             RETURNED IN ITS PLACE.
C    NDIM   - THE SIZE TO WHICH A IS DIMENSIONED

COMPLEX A(NDIM,NDIM),PIVOT(100),AMAX,T,SWAP,DETERM,U
INTEGER*4 IPIVOT(100),INDEX(100,2)
REAL TEMP,ALPHA(100)

C
C    INITIALIZATION
C
DETERM=CMPLX(1.0,0.0)
DC 20 J=1,N
ALPHA (J)=0.000
DC 10 I=1,N
10 ALPHA(J)=ALPHA(J)+A(J,I)*CONJG(A(J,I))
ALPHA(J)=SQRT(ALPHA(J))
20 IPIVOT(J)=0
DC 600 I=1,N

C
C    SEARCH FOR PIVOT ELEMENT
C
AMAX=CMPLX(0.0,0.0)
DO 105 J=1,N
IF (IPIVOT(J)-1) 60,105,60
60 DC 100 K=1,N
IF (IPIVOT(K)-1) 80,100,740
80 TEMP=AMAX*CONJG(AMAX)-A(J,K)*CONJG(A(J,K))
IF(TEMP) 85, 85, 100
85 IROW=J
ICOLUM=K
AMAX=A(J,K)
100 CONTINUE
105 CONTINUE
IPIVOT(ICOLUM)=IPIVOT(ICOLUM)+1

C
C    INTERCHANGE ROWS TO PUT PIVOT ELEMENT ON DIAGONAL
C
IF(IROW-ICOLUM) 140, 260, 140
140 DETERM=DETERM
DO 200 L=1,N
SWAP=A(IROW,L)

```



```

A(IROW,L)=A(ICOLUM,L)
200 A(ICOLUM,L)=SWAP
    SWAP=ALPHA(IROW)
    ALPHA(IROW)=ALPHA(ICOLUM)
    ALPHA(ICOLUM)=SWAP
260 INDEX(I,1)=IROW
    INDEX(I,2)=ICOLUM
    PIVOT(I)=A(ICOLUM,ICOLUM)
    U=PIVOT(I)
    TEMP=PIVOT(I)*CONJG(PIVOT(I))
    IF(TEMP) 330, 720, 330
C
C
C    DIVIDE PIVOT ROW BY PIVOT ELEMENT
330 A(ICOLUM,ICOLUM)=CMPLX(1.0,0.0)
    DO 350 L=1,N
    U=PIVOT(I)
350 A(ICOLUM,L)=A(ICOLUM,L)/U
C
C
C    REDUCE NON-PIVOT ROWS
380 DO 550 L1=1,N
    IF(L1-ICOLUM) 400, 550, 400
400 T=A(L1,ICOLUM)
    A(L1,ICOLUM)=CMPLX(0.0,0.0)
    DO 450 L=1,N
    U=A(ICOLUM,L)
450 A(L1,L)=A(L1,L)-U*T
550 CCNTINUE
600 CONTINUE
C
C
C    INTERCHANGE COLUMNS
620 DO 710 I=1,N
    L=N+1-I
    IF(INDEX(L,1)-INDEX(L,2)) 630, 710, 630
630 JRCW=INDEX(L,1)
    JCOLUM=INDEX(L,2)
    DO 705 K=1,N
    SWAP=A(K,JROW)
    A(K,JROW)=A(K,JCOLUM)
    A(K,JCOLUM)=SWAP
705 CCNTINUE
710 CCNTINUE
    RETURN
720 WRITE(6,730)
730 FORMAT(20H MATRIX IS SINGULAR)
740 RETURN
    END

```

BIBLIOGRAPHY

1. Silvester, Dr., "TEM Wave Properties of Microstrip Transmission," IEE Proceedings, Vol. 115, No. 1, p. 43-48, Jan. 1968.
2. Harrington, Roger F., Field Computation by Moment Methods, p. 62-73, The MacMillan Company, 1968.

INITIAL DISTRIBUTION LIST

	No. Copies
1. Library, Code 0212 Naval Postgraduate School Monterey, California 93940	2
2. Defense Documentation Center Cameron Station Alexandria, Virginia 22314	2
3. Asst Professor J. B. Knorr, Code 52 Ko Department of Electrical Engineering Naval Postgraduate School Monterey, California 93940	1
4. Asst Professor R. A. Adler, Code 52 Ab Department of Electrical Engineering Naval Postgraduate School Monterey, California 93940	1
5. Ens. John F. Timony 151 Farragut Avenue Vallejo, California 94590	1
6. Dr. Sydney R. Parker, Code 52 Department Chairman, Naval Postgraduate School Department of Electrical Engineering Monterey, CA 93940	1

DOCUMENT CONTROL DATA - R & D

(Security classification of title, body of abstract and indexing annotation must be entered when the overall report is classified)

1. ORIGINATING ACTIVITY (Corporate author) Naval Postgraduate School Monterey, California 93940		2a. REPORT SECURITY CLASSIFICATION Unclassified	
		2b. GROUP	
3. REPORT TITLE An Investigation on the Application of the Method of Partial Images to a Dynamic Problem			
4. DESCRIPTIVE NOTES (Type of report and inclusive dates) Master's Thesis: June 1973			
5. AUTHOR(S) (First name, middle initial, last name) John Francis Timony			
6. REPORT DATE June 1973		7a. TOTAL NO. OF PAGES 45	7b. NO. OF REFS 2
8a. CONTRACT OR GRANT NO.		8a. ORIGINATOR'S REPORT NUMBER(S)	
b. PROJECT NO.			
c.		9b. OTHER REPORT NO(S) (Any other numbers that may be assigned this report)	
d.			
10. DISTRIBUTION STATEMENT Approved for public release; distribution unlimited.			
11. SUPPLEMENTARY NOTES		12. SPONSORING MILITARY ACTIVITY Naval Postgraduate School Monterey, California 93940	
13. ABSTRACT The Method of Partial Images has been successfully applied to electrostatic problems involving conductors on a dielectric substrate. This same method is investigated for its adaptation to dynamic problems. A Green's Function is derived and applied to the problem of a wire dipole antenna on a dielectric substrate. The input admittance of the antenna is computed by the Method of Moments. Experimentally measured values of input admittance are compared with the theoretical values and the error is discussed.			

KEY WORDS

Method of Partial Images
Green's Function

LINK A		LINK B		LINK C	
ROLE	WT	ROLE	WT	ROLE	WT



Thesis
T513
c.1

Timony

145482

An investigation on
the application of the
method of partial images
to a dynamic problem.

Thesis
T513
c.1

Timony

145482

An investigation on
the application of the
method of partial images
to a dynamic problem.

thesT513

An investigation on the application of t



3 2768 001 0117 4

DUDLEY KNOX LIBRARY