



**Calhoun: The NPS Institutional Archive**

---

Theses and Dissertations

Thesis Collection

---

1967

## Aeronautical applications of holographic interferometry.

Holds, James Howard.

Monterey, California. U.S. Naval Postgraduate School

---

<http://hdl.handle.net/10945/11566>



Calhoun is a project of the Dudley Knox Library at NPS, furthering the precepts and goals of open government and government transparency. All information contained herein has been approved for release by the NPS Public Affairs Officer.

**Dudley Knox Library / Naval Postgraduate School**  
**411 Dyer Road / 1 University Circle**  
**Monterey, California USA 93943**

<http://www.nps.edu/library>

NPS ARCHIVE  
1967  
HOLDS, J.

AERONAUTICAL APPLICATIONS OF  
HOLOGRAPHIC INTERFEROMETRY

JAMES HOWARD HOLDS

1954

POSTGRADUATE SCHOOL  
CALIF. 93940









AERONAUTICAL APPLICATIONS OF

HOLOGRAPHIC INTERFEROMETRY

by

James Howard Holds  
Lieutenant, United States Navy  
B. S., Naval Academy, 1959

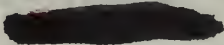

Submitted in partial fulfillment of the  
requirements for the degree of

MASTER OF SCIENCE IN AERONAUTICAL ENGINEERING

from the

NAVAL POSTGRADUATE SCHOOL  
June 1967



07  
LDS, J.

ABSTRACT

The advent of holography and the laser as an extremely intense, coherent light source has opened new dimensions in interferometric techniques. Precision optics are not required, alignment is not a critical factor, and three-dimensional interferograms of a flow field are obtainable. These are only a few of the advantages that stand out over present day interferometers. A brief outline of the holographic interferometric process and its capabilities is presented here. A detailed exposition of the continuous reconstruction beam technique is given from experience gained with such a device in the Department of Aeronautics of the Naval Postgraduate School.

LIBRARY  
NAVAL POSTGRADUATE SCHOOL  
MONTEREY, CALIF. 93940

ERRATA

- page 6, last line: change to read "expended"  
vice "Expended".
- page 23, line 14: change to read "plexiglass"  
vice "plixiglass".
- page 26, line 17: change to read "fringe"  
vice "frings".
- page 26, line 18: change to read "prediction"  
vice "prodiction".
- page 28, item 12: change to read "Liepmann, H.W.,  
and Roshko, A., Elements of Gas Dynamics,  
(London: John Wiley and Sons, Inc., 1957),  
Chapter 6."



## TABLE OF CONTENTS

	Page No.
List of Illustrations	5
Acknowledgements	6
I. Introduction	7
II. The Holographic Process	10
III. A Refined Analysis of a Holographic Interferogram	13
IV. A Continuous Beam Interferometer	17
V. Dark Field Holograms	21
VI. Light Field Holograms	25
VII. Summary and Recommendations	26
References	28
Illustrations	30
Bibliography	41
Distribution	43



## LIST OF ILLUSTRATIONS

1. Plan Schematic of a Classical Mach-Zehnder Interferometer.
2. Plan Schematic of a Holographic Interferometer.
3. Infinite Fringe Interferogram of a .22 Caliber Bullet in Krypton at Mach 2.5, Taken through a Multiple Exposure Hologram.
4. Light Reconstruction Process: (a,b) are Orders of Diffraction of the Direct and Prism Beams Respectively.
5. Comparison of Solutions Superposed on a Copy of the Original Interferogram.
6. Density Distribution in Conical Flow from Busemann Construction.
7. Geometry of the Conical Flow Problem.
8. Basis for Evaluating  $I(\omega)$ .
9. A Continuous Beam Holographic Interferometer at the Naval Post-graduate School.
10. Interferogram of  $40^\circ$  Cone at Mach 2.7: Infinite and Finite Fringe. Dots Represent Variable Density Solution of Fringe Prediction.
11. Dark Field Interferograms of Various Subjects.

## ACKNOWLEDGEMENTS

The author wishes to express sincere appreciation to his thesis advisor, Professor Allen E. Fuhs, for his interest and enthusiasm for this project. He was always available for counsel and could be counted on to help out when problem areas arose.

Thanks are also due to L. O. Heflinger, R. F. Wuerker, and R. W. Brooks of TRW Systems. These gentlemen, whose work leads the field in holographic interferometry, have given generous support to this project. A tour of their facilities at Redondo Beach, California, at the inception of the project has proven invaluable, as has their continuing liaison with Professor Fuhs.

The Visual Aids Department of the Naval Postgraduate School has provided excellent photographic support. R. T. Dubrau and David Lambert are to be commended for their interest in solving the unique problems that have arisen from the photographic aspects of the project.

Special thanks go to E. F. Calvin and N. Leckenby, technicians in the Department of Aeronautics. The interest shown and the efforts expended by these two gentlemen assured success of the project.

## I. INTRODUCTION

The first LASER (Light Amplification by Stimulated Emission of Radiation) was achieved in 1960 by Maiman using a ruby crystal in a pulsed mode. Shortly thereafter continuous operation of a gas laser was achieved by Javan. The high monochromaticity (time coherence) and exceptional directionality (spatial coherence) of the laser have opened the door to vast new fields of technology that have barely been tapped. One of these fields is wavefront reconstruction, or holographic photography. This particular science has produced interferometric techniques which have several desirable qualities.

Heflinger, Wuerker, and Brooks of TRW Systems have developed such techniques which are especially suitable for the analysis of fluid flow phenomena. Their work has been with both multiply exposed interferograms using a giant pulse laser<sup>1</sup> and holographically reconstructed comparison beams using a continuous gas laser.<sup>2</sup> Application of these techniques has shown that (1) accurate alignment is not critical, (2) precision optical components are not required, (3) three-dimensional interferograms are obtainable, and (4) the technique may be used to observe either transient or stationary phenomena. The full impact of these qualities cannot be fully appreciated unless one examines existing interferometers.

The classical Mach-Zehnder interferometer is in use contemporarily in aeronautical test laboratories throughout the world. This system, developed in 1891, was a minor modification of the Jamin interferometer



operated in 1865.<sup>3</sup> Examining the requirements of this system, it becomes readily evident why the holographic interferometer is a desirable concept to pursue. The optical elements must be of the finest quality obtainable. The alignment of the four optical plates which compose the heart of the system must be accurate to within a fraction of a wavelength of light. And finally, the structure supporting such a system has generally been of massive proportions to eliminate vibration.<sup>4</sup> Recent work has been done on the use of light, heavily damped mounts;<sup>5</sup> however, most existing systems use the former mounting. Figure 1 shows a typical plan layout of a Mach-Zehnder interferometer for comparison with the holographic interferometer.

Figure 2 shows the plan layout of a continuous reconstruction beam holographic interferometer. Note that the optical components of this system consist of only two lenses and a prism, and the quality of these components is not critical. A system such as this overcomes every drawback of the Mach-Zehnder interferometer and even challenges the much used schlieren system for simplicity, since high quality optics are a factor in the latter. Production of a lightweight, inexpensive interferometer which is readily maintained and adjusted and, in addition, is suitable for wind tunnel use is certainly a desirable objective. The holographic interferometer makes such a device practicable.

This thesis contains an exposition of the techniques involved in holographic interferometry. It will explore the quantitative capability of the multiple exposure method with a refined analysis of a fringe

prediction contained in Reference 1. It will detail fabrication and operation of a continuous reconstruction beam type interferometer within the Department of Aeronautics of the Naval Postgraduate School at Monterey, California, and it will provide results of the use of this interferometer in the analysis of flow phenomena in the school's supersonic wind tunnel.

## II. THE HOLOGRAPHIC PROCESS

The holographic process itself is not entirely new and was first presented by Gabor in the Proceedings of the Royal Society in 1949.<sup>6</sup> Gabor dealt with microscopic techniques, and he coined the term hologram for his first wavefront reconstructions. Early workers in other fields besides microscopy produced holograms (the recorded diffraction pattern) of very simple scenes such as transparencies with dark lettering. This precluded light scattering which resulted in loss of phase information on the incident beam.

In 1963, using a continuous wave He-Ne gas laser, Leith and Upatnieks accomplished wavefront reconstruction on continuous tone objects.<sup>7</sup> They noted that the brilliance, spatial coherence, and monochromaticity of the laser greatly facilitated their work. Such a process is possible using a mercury arc lamp with a Mach-Zehnder interferometer,<sup>8</sup> but the complexities of the Mach-Zehnder limit the applicability of the technique.

Exposing a high resolution plate to a scene in a test beam and to a reference beam, as shown in Figure 2, creates a diffraction grating within the emulsion. The spacing of this grating is inversely proportional to the sine of the angle between the two beams. If the plate is developed and reilluminated by coherent light, the grating will cause the incident light to be diffracted into a reproduction of the original scene. That is, it will reconstruct the light wave pattern incident upon it at the time of exposure. If the plate is exposed to two scenes, then, upon reconstruction it will contain a superposition of the light patterns of the scenes.

The superposition phenomenon just mentioned is the basis for multiple exposure holographic interferometry. The plate is exposed to any undisturbed reference scene. A disturbance is then introduced which causes changes in optical path length, and the plate is exposed again. The resulting hologram will contain the interference pattern of the disturbance. It will be an infinite fringe interferogram, containing lines of constant density (isopycnals) for two-dimensional flow. Such a technique is ideally suited to transient hypervelocity phenomena such as occur in ballistic studies. Heflinger, Wuerker, and Brooks used this technique with a Q-switched ruby laser to gain excellent interferograms of a .22 caliber bullet at supersonic velocities in various gases.<sup>2</sup> Exposure times involved were in the nano-second range. Figure 3 contains a reproduction of one of these interferograms. Note the outstanding fringe definition. Multiple exposure holographic techniques, then, provide a permanent record of an optical event which may be reconstructed with coherent light at will.

In order to view some interference phenomena continuously it is possible to make a hologram of the undisturbed reference scene. When this hologram is replaced in the setup, it is possible to view the reference scene through it as through a window. Any disturbance as before will cause interference, and the resultant fringes may be viewed or photographed. This is the type of interferometer that is dealt with in detail in Section IV.

Interference theory, per se, will not be dealt with in this thesis as the details are contained in any basic physics text. Fringe prediction is covered in Section III, and references are made to complete

expositions of such techniques. It should be noted, however, that a hologram made in the setup, as shown in Figure 2, is nothing more than a very fine, nominally parallel, diffraction grating created by the angular difference between the scene and the prism beam incident upon the plate. It is the changes of optical path length due to subsequent perturbations in the scene which manifest themselves as visible interference fringes upon the extremely fine diffraction grating of the hologram. Figure 4 shows the mechanics of the reconstruction process on a plate which has been exposed to scene and prism beam as in Figure 2. Either combination of a zero and a one order of diffraction provides high contrast fringing.

A very recent development in the field is three-beam holography,<sup>9</sup> which is said to double the sensitivity to phase variation compared to single continuous beam and multiple exposure holographic interferometry.

### III. A REFINED ANALYSIS OF A HOLOGRAPHIC INTERFEROGRAM

To test the quantitative capability of the holographic interferometric technique Heflinger, Wuerker, and Brooks<sup>1</sup> obtained an interferogram of a .22 caliber projectile with a conical tip at Mach number of 2.5 in a krypton atmosphere. Theoretical calculations assuming constant density yielded fringes which were compared with the observed interferogram. Heflinger, Wuerker, and Brooks recognized that the density was not constant between the conical shock and the surface of the cone. A constant density assumption leads to a fairly good fit between theoretical and observed fringes as can be seen by the dots in Figure 5.

Careful examination of Figure 5 shows that as the fringe number increases, the predicted fringe occurs downstream of the observed fringe. Note especially fringes for  $N = 5/2$  and  $7/2$ . It is of interest to account for the variation of density. Conical flow is one of the few compressible flow fields which is not two-dimensional planar and which can be solved without lengthy numerical calculations. The results of such a calculation verify even more closely the capability of the holographic interferometer.

The density distribution within the conical flow region was determined using a graphical Busemann solution,<sup>10</sup> commonly known as an apple curve due to its characteristic shape in the hodograph plane. To apply the Busemann graphical technique it is necessary to have the shock wave angle, ratios of properties across the oblique shock, and the turning angle of the flow immediately downstream of the conical shock. These data were obtained from the NASA Report, by Henderson and Braswell,<sup>11</sup>

which is for helium; however, since helium and krypton have the same ratio of heat capacities,  $\gamma = C_p/C_v$ , the calculations are applicable to krypton. The observed shock wave was within  $0.5^\circ$  of the value predicted by the NASA Report. Conditions at the surface of the cone from the apple curve solution and the NASA Report were identical. Figure 6 shows the density ratio (local density divided by freestream density) as a function of angle  $\omega$  which is defined in Figure 7.

The fringe shift calculation with variable density was based on the following formula:

$$N = Cx \int_0^{\frac{L}{x}} \left( \frac{\rho}{\rho_1} - 1 \right) \frac{ds}{x} \quad (1)$$

where the symbols have the meaning:

$N$  = fringe number

$C$  = constant

$L$  = geometrical path length

$ds$  = element of geometrical path length

$x$  = axial station

$\rho_1$  = density ahead of shock cone

Figure 7 illustrates the geometry related to Equation (1). Equation (1) is a slightly modified version of a fringe shift formula derived by Liepmann and Roshko.<sup>12</sup> The constant  $C$ , which has the dimension per unit length, depends on density  $\rho_1$ , the wavelength of light  $\lambda$ , and the Gladstone-Dale constant  $K$ . It is

$$C = \frac{2 \cdot \rho_1}{\lambda} \quad (2)$$

For the conditions of the test  $K\rho_1 = 3.98 \times 10^{-4}$  and  $\lambda = 6943 \text{ \AA}$ .

With the density field data from the Busemann solution it is possible to evaluate the integral

$$I(\omega) = \int_0^{\frac{L}{x}} \left( \frac{\rho}{\rho_1} - 1 \right) \frac{ds}{x} \quad (3)$$

Figure 8 contains the basis for this integration at discrete values of  $\omega$  and is a plot of  $(\rho/\rho_1 - 1)$  versus nondimensional pathlength  $(s/x)$ . Note that  $L/x$  is a function of angle  $\omega$ ; see Figure 7. For a given fringe, i.e.,  $N = 1/2, 3/2, 5/2$ , etc., the axial station  $x$  may be predicted from

$$x = \frac{N}{CI(\omega)} \quad (4)$$

A more extensive and thorough exposition of such fringe predictions may be found in References 13 and 14 in which Taylor-Maccoll conical flow solutions were used.

The results of the fringe prediction obtained from Equations (1) to (4) and Figure 6 have been plotted on the left side of Figure 5 as solid lines. Use of variable density shifts the predicted fringes slightly upstream of the observed fringes. It should be emphasized that the predicted fringes were obtained without any adjustable parameters. All numerical values were obtained from gas properties ( $\gamma$  and  $\kappa$ ), flow properties ( $M$  and  $\rho$ ), and optical data ( $\lambda$ ).

For the fringes plotted as solid lines on the right side of Figure 5, the quantity  $C$  was taken as an adjustable parameter. One value for  $C$  was assigned to give optimum fit of predicted to observed fringes.



From the Busemann construction for conical flow one has Mach number and direction of flow velocity as functions of  $\omega$ . Using these data, bounding characteristics were also plotted in Figure 5. These appear at the edge of the crosshatched region in the lower portion of the figure. The shoulders of the transition from cone to cylinder are slightly rounded. The characteristics, which have a slope equal to the local Mach angle, are drawn from the leading edge of the rounded corner.

It is evident from Figure 5 that the variable density fringe calculations more closely predict the shape and location of the fringes and verify the quantitative capability of the technique.

#### IV. A CONTINUOUS BEAM INTERFEROMETER

The holographic interferometer built at the Naval Postgraduate School uses as a coherent light source a continuous emission helium-neon laser from Spectra-Physics, Inc. It is the Model 124 with a rated minimum power output of 15.0 milliwatts at a wavelength of 6328 Angstrom units, which is within the red region of the visible spectrum. The output beam has a diameter of 1.1 millimeters and divergence of 1.0 milliradians. The amplitude stability of the output is better than 3 per cent on a long term basis.

The plasma exciter is a DC self-starting device requiring 250 volt-amps and 115 volts AC  $\pm$  10 volts. The weight of the laser and exciter is less than 30 pounds.

The Model 124 has optional wavelengths available at 6118, 11523, and 33910 Angstrom units. These wavelengths are obtainable using an adjustable prism. They are available at a very low power due to the stimulated emission characteristics of the helium-neon plasma.

The very small diameter output beam must be expanded in a convenient distance and shielded to avoid creating any eye hazard.<sup>15</sup> These two aims were accomplished by placing a 5X microscope objective at the output aperture of the laser. Further beam expansion is accomplished using a double concave lens with a negative ten centimeter focal length. Various diameter and focal length collimating lenses can be used compatible with space available and area of the test scene. The maximum rectangular

test scene through a lens is  $a \times 2a$  where:

$$a = \frac{R}{\sqrt{2}} ; \quad R = \text{Lens Radius}$$

One of the most used collimators has a diameter of 200 millimeters and focal length of 1200 millimeters.

After the test area the prism must be placed to superpose the reference beam on the holographic plate. Ten and twenty degree prisms were cut from plexiglass blocks and hand polished. Their rectangular dimension is 4 x 6 inches to provide adequate coverage of the usual 4 x 5 inch plate.

The plate holder itself is a device in which the plates may be exposed and returned precisely to their original position after developing. Its essential characteristics are positioning blocks and a clamping feature.

All components are attached with standard optical bench accessories to several optical benches which are secured to a 4 x 8 inch aluminum structural beam for rigidity of the entire system. This layout is 10 feet long and may be used on a laboratory table or mounted on stands for wind tunnel use. Figure 9 contains a photograph of the layout.

It should be noted that the optical components of the layout are not of top quality and were chosen more for size and focal length compatibility than any other feature. Using coherent laser light optical quality is not a factor as long as optical path is maintained.

Initial experiments were made using a small Optics Technology laser with a fraction of a milliwatt output power. A 1/4 x 1/2 inch hologram was produced and fringes noted in a piece of plexiglass. The size of the scene was not conducive to further work at low power levels.

The holograms are produced on Kodak 649F Spectroscopic Plate. This emulsion has extremely slow (ASA = .003), high resolution (2500 lines/millimeter) characteristics. The wavefront reconstruction capability lies in this high resolution plate and its ability to produce an extremely fine diffraction grating of the same order of magnitude as a wavelength of light.

Two-dimensional, dark field, holograms may be produced using the setup as shown in Figure 2. These may be adjusted to produce finite fringes of any orientation or spacing desired. Adjustments are accomplished by rotating the prism and rotating or tilting the hologram.

Typical hologram sizes are 2 x 4 inches. Exposure time on the holograms is approximately 5 seconds with the beam expanded to give a uniform intensity for the 4 x 5 inch scene size. The plates are then developed in a high resolution plate developer for five minutes with a standard stop, fix, and rinse cycle. All work with the spectroscopic plates should be done in complete darkness to avoid fogging of the plates. An OA type filter was used during initial work with the plates, and fogging did occur. The most important single factor during plate exposure is a vibration free environment.

Most holograms were exposed at night to obtain both darkness and reduce vibration problems. If vibration does occur during exposure, the

hologram is rendered useless. During exposures on the supersonic wind tunnel the interferometer was mounted on an insulated "floating" floor block designed for a Mach-Zehnder interferometer. No difficulty was encountered with this setup. Successful holograms were achieved with exposure times of up to thirty seconds.

Photography was accomplished with a large diameter, 286 millimeter focal length lens and a camera back. The focal plane shutter incorporated in the camera had an exposure capability of 1 millisecond. This speed was compatible with Polaroid ASA 3000 film. In certain cases too much light was available, and it was attenuated with a single polarizing filter. This capability is possible due to the fact that the laser beam is polarized.

## V. DARK FIELD HOLOGRAMS

When no ground glass diffusing plate is used in the test beam, the resulting hologram is called dark field and is useful in a two-dimensional sense. To look through the hologram at the test scene would not only be uncomfortable, looking into the laser source, but could cause permanent eye damage. Some safety experts have placed the minimum amount of continuous incident optical power that can be safely sighted and focused by the eye at 1 microwatt for the 6328 Angstrom units wavelength. Above this there is a possibility of permanent retinal damage.

To avoid the possibility of eye damage the collimated light through the test scene and hologram was allowed to project on a screen or directly on a photographic plate for recording interference patterns. This projection consisted of the direct scene plus the orders of diffraction that are shown in Figure 4. The interference patterns are identical in each order using this method, and the intensity of the first order in line with the prism beam is comparable to that of the zero order or direct scene projection.

These dark field holograms are most useful when observing subtle density changes in an open field. One may make interferometric analysis of heated bodies, flames, or flow of liquids or gases in transparent channels. In the latter case the transparent channel must be present when the scene hologram is made.

Early attempts to record the interference patterns, as noted above, used only a film holder and shutter arrangement. The projected beam,

however, produced grossly inferior interferograms due to spurious fringes on the body and on shock waves. These were due to diffraction phenomena creating additional interference at the holograms.

These problems were overcome entirely by focusing the camera noted in Section IV on the object creating interference in the field. Photography is also possible using the prism beam since the intensity is equal to that of the direct beam. The absence of the object from this scene, however, might cause some confusion when attempting to reduce the interferograms.

The dark field technique was used on the 4 x 4 inch supersonic wind tunnel at the Postgraduate School to investigate the flow about a 40° cone model. A cone was chosen since the method of fringe prediction coincides with that of Section II and could be extended without detailing the procedure.

While working with this arrangement it was found that a wide range of fringe orientation and spacing could be achieved. This was accomplished not only by rotating the prism and tilting the hologram, but also by moving the expanding or collimating lenses. Such flexibility of the system is remarkable. For instance, the expanding lens could be moved within a range of 2 centimeters without losing the fringes. The movement of the prism and hologram was more critical. It would be desirable to include micrometer adjustments on these components in future installations.

Figure 10 shows two interferograms of the 40° cone at Mach 2.7. The upper half of the figure is an infinite fringe representation and

includes the fringe prediction using methods of Section II. The lower half of the figure is finite fringe to indicate that capability of the interferometer.

High fringe contrast is to be noted and also the good agreement between predicted and actual fringes. The maximum relative error is less than 3 per cent.

The interferometer performed very well in conjunction with the wind tunnel. Vibration problems were generally easily overcome and created no serious difficulties. The existing circular windows in the test section greatly reduced the size of the scene available. This was due to the necessity of passing both the direct and prism beams through the forward half of the window. Work is now being completed on plexiglass side windows which will open up the entire nozzle block. Interferometry through the plexiglass will be possible since optical quality is not critical. This will greatly increase the capability of this installation for utilization of the holographic interferometer.

Figure 11 shows several finite fringe interferograms recorded through a hologram exposed to an open field. The scene was at atmospheric pressure and 70° Fahrenheit. The size of the hologram was approximately 3 x 4 inches. The entire layout of the interferometer was the same as used on the wind tunnel with the test scene oriented in the area abeam of the prism.

Test subjects introduced into the field included a heated rod and plate to observe temperature gradients and convective effects in the



the airflow about them. A match flame showed clearly the temperature distribution around it. A microscope slide glass was used to observe the optical flaws in it.

The reduction of finite fringe interferograms may be found in most complete texts on fluid flow or heat transfer.

The dark field method, using a continuous beam, is very suitable for wind tunnel and heat transfer study use. It has two other properties that also recommend its further development. There is sufficient intensity to make motion pictures of transient events, and the scene itself may be projected on a screen for instructional purposes.

## VI. LIGHT FIELD HOLOGRAMS

If a frosted glass plate is introduced into the scene beam of the interferometer, as shown in Figure 2, the resulting hologram will contain a completely three-dimensional reproduction of the scene. This is a light-field hologram. When it is replaced in the plate holder, a disturbance of the scene may be viewed through the hologram as if it were a "window". The interference pattern of any disturbance is completely three-dimensional in nature and may be viewed from different angles.

The light field technique is applicable to both the multiple exposure and continuous beam methods of interferometry. Figures 3 and 5 were both recorded through a double exposure hologram which was produced using light field techniques. Reference 1 contains excellent photographic evidence of the three-dimensional nature of the interferogram with a series of pictures taken at different camera angles. The pictures show clearly how the interference pattern shifts as the visual reference is changed.

Such an interferogram leads to the possibility of solution of the three-dimensional flow fields that defy mathematical closed form solutions. Such a process would necessarily require three views to locate points in the flow field, and then the flow properties could possibly be derived by correlating the fringe information contained in the three two-dimensional interferograms.

The light field technique has no counterpart in current interferometry. Its three-dimensional nature is unique. The extension of this technique to solve problems in complicated fluid flow fields and heat transfer problems is indicated.

## VII. SUMMARY AND RECOMMENDATIONS

Experience gained with the continuous beam holographic interferometer described in Section IV indicates that it is very well suited for experimental work in fluid flow investigations. It overcomes all of the drawbacks of the Mach-Zehnder interferometer and decreases the difficulty of interferometry by several orders of magnitude. The mechanics of the technique are only slightly more complex than those involved in obtaining shadowgraphs.

The contentions that optical quality and alignment are not critical factors have been adequately substantiated. The use of a plastic prism and ground glass proves the former. Manual adjustment of lenses, prism, and hologram bears out the latter.

The light weight and potential high mobility of the system make it ideal for laboratories where many different projects may use interferometric analysis in their studies.

The quantitative capability of the technique has been amply proven with the refinement to the frings prediction of the .22 caliber bullet and the good agreement between the  $40^\circ$  cone prodiction and the actual interferogram.

Recommendations arising from this research may be considered in two categories: technical and philisophical. Technically, several improvements in the physical layout would improve its capability: (1) micrometer adjustments should be incorporated in the prism and hologram mounts to facilitate fringe orientation; (2) a prism with a larger turning angle should be incorporated, which would allow moving the hologram

closer to the scene to facilitate closeup photography; (3) a spatial filter should be incorporated in the beam-expanding system for a more uniform light intensity; (4) an optical power meter should be obtained in order that the optimum optical output power of the laser may be obtained.

Philosophically, the holographic interferometer certainly holds within reach the solution to many problems heretofore unsolvable. This capability is due to the three-dimensional nature of the interferometry. It is felt that future research in this subject should be directed primarily at the light field technique and the reduction of the information contained.

The existing interferometer should be used vigorously, and is certainly capable of making interferometric analysis of subjects ranging from burning propellant grains to flow through transparent channels. The fabrication of additional interferometers sharing available laser sources would be a relatively simple matter. When one thinks of the interferometer as beginning in a collimated beam, it consists of only the prism and the hologram. Therefore adjustable holders for those components and a suitable mount are all that would be required.

## REFERENCES

1. Heflinger, L. O., Wuerker, R. F., and Brooks, R. E., "Holographic Interferometry," Journal of Applied Physics, 37 (1966), pp. 642-649.
2. Brooks, R. E., Heflinger, L. O., and Wuerker, R. F., "Interferometry with a Holographically Reconstructed Comparison Beam," Applied Physics Letters, (Nov. 1, 1965).
3. Tolansky, S., An Introduction to Interferometry, (New York: Longmans, Green and Co., 1955), p. 115.
4. Liepman, H. W., and Roshko, A., Elements of Gas Dynamics, (London: John Wiley and Sons, Inc., 1957), p. 165.
5. Ashkenas, H. I. and Bryson, A. E. "Design and Performance of Simple Interferometer for Wind-Tunnel Measurements," Journal of Aeronautical Sciences, 18 (1951), p. 82.
6. Gabor, D., "Microscopy by Reconstructed Wavefronts," Proceedings of the Royal Society, London, A197 (1949), p. 454.
7. Leith, E., and Upatnieks, "Wavefront Reconstruction with Continuous Tone Objects," Journal of the Optical Society of America, 53 (1963), p. 1377.
8. Leith, E., and Upatnieks, "Reconstructed Wavefronts and Communications Theory," Journal of the Optical Society of America, 52 (1962), p. 1123.
9. Manoranjan De, and Sevigny, L., "Three Beam Holography," Applied Physics Letters, 10 (Feb. 1, 1967), p. 78.
10. Shapiro, A. H., The Dynamics and Thermodynamics of Compressible Fluid Flow, (New York: The Ronald Press Co., 1954), Chapter 17.
11. Henderson, A., and Braswell, D. O., "Charts for Conical and Two-Dimensional Oblique Shock Parameters in Helium at Mach Numbers from about 1 to 100," NASA TN-D819, (June 1961).
12. Liepman Roshko, Chapter 6.
13. Bennett, F. D., Carter, W. C., and Bergdolt, V. E., "Interferometric Analysis of Airflow about Projectiles in Free Flight," Journal of Applied Physics, 23 (1952), pp. 453-469.

REFERENCES (CONTINUED)

14. Giese, J. H., Bennett, F. D., and Bergdolt, V. E., "A Simple Interferometric Test for Conical Flow," Journal of Applied Physics, 21 (1950), pp. 1226-1231.
15. Kohtiao, A., Newton, J., Schwell, H., and Resnick, I., "Hazards and Physiological Effects of Laser Radiation," Annals of The New York Academy of Sciences, 122 (Mar. 28, 1965), pp. 777-779.

**PLAN SCHEMATIC OF A CLASSICAL  
MACH-ZEHNDER INTERFEROMETER**

Collimating  
Mirror

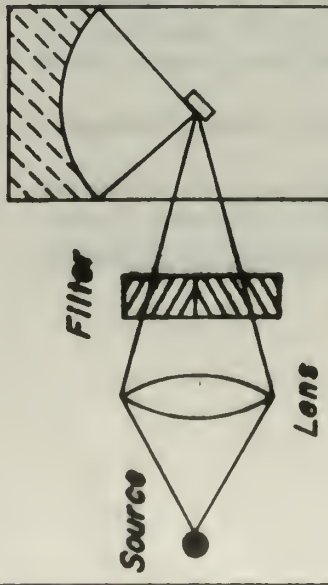

$P_2$  and  $P_3$  Totally  
Reflective Optical Plates

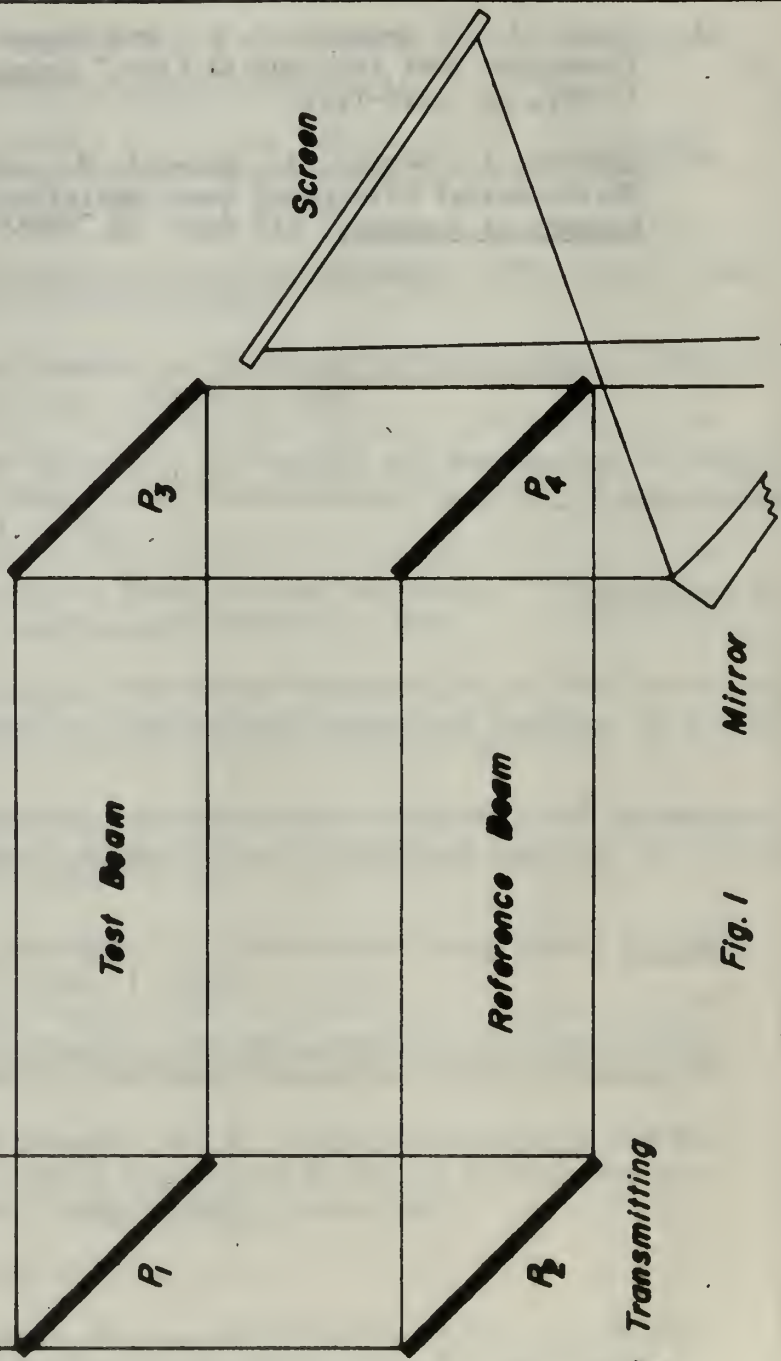

$P_1$  and  $P_2$  Partially Transmitting  
Optical Plates

Mirror

Screen

Fig. 1

PLAN SCHEMATIC OF A  
HOLOGRAPHIC INTERFEROMETER

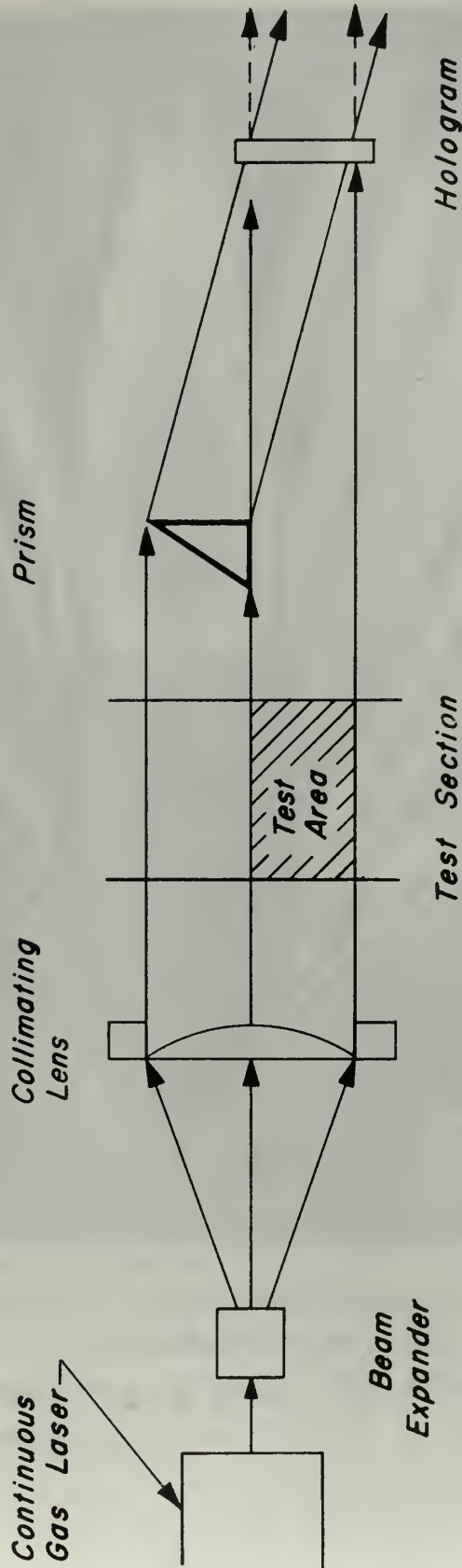
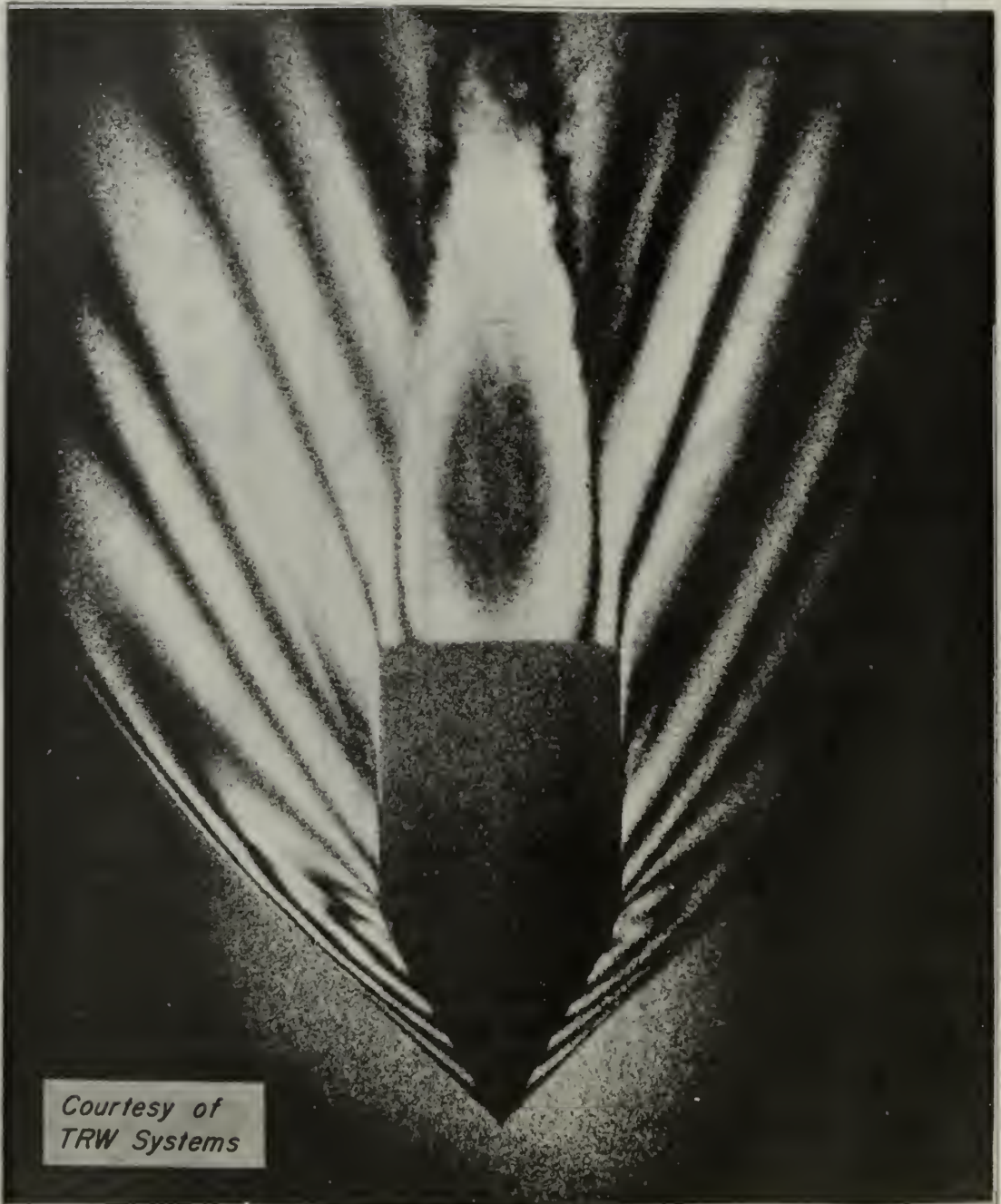

Fig. 2





Courtesy of  
TRW Systems

*Fig.3 INFINITE FRINGE INTERFEROGRAM  
OF A .22 CALIBER BULLET IN KRYPTON  
AT MACH 2.5. TAKEN THROUGH A  
MULTIPLE EXPOSURE HOLOGRAM.*

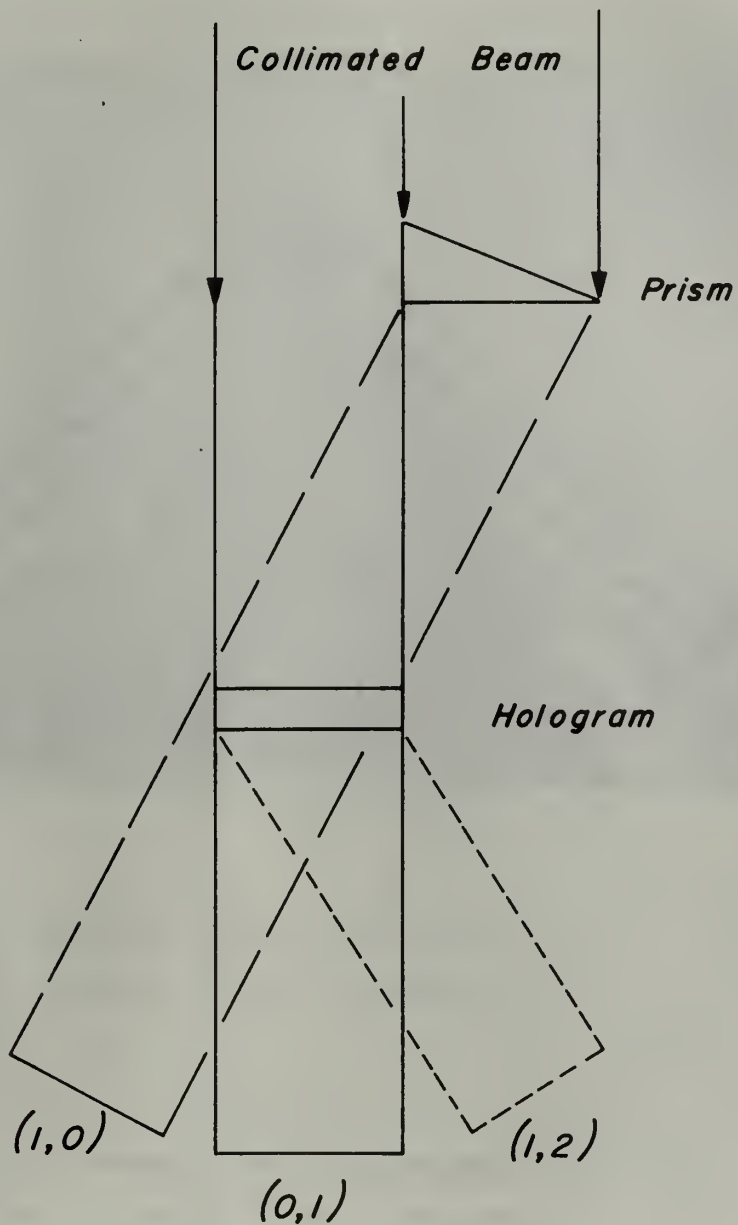

LIGHT RECONSTRUCTION PROCESS  
 $(a,b)$  ARE ORDERS OF DIFFRACTION  
 OF THE DIRECT AND PRISM BEAMS  
 RESPECTIVELY.

Fig. 4

*Courtesy of  
TRW Systems*



*..... Constant Density Solution*

*—— Variable Density Solution*

*Comparison of Solutions  
Superposed on a Copy of the  
Original Interferogram*

*Fig. 5*

DENSITY DISTRIBUTION IN CONICAL FLOW  
FROM BUSEMANN CONSTRUCTION

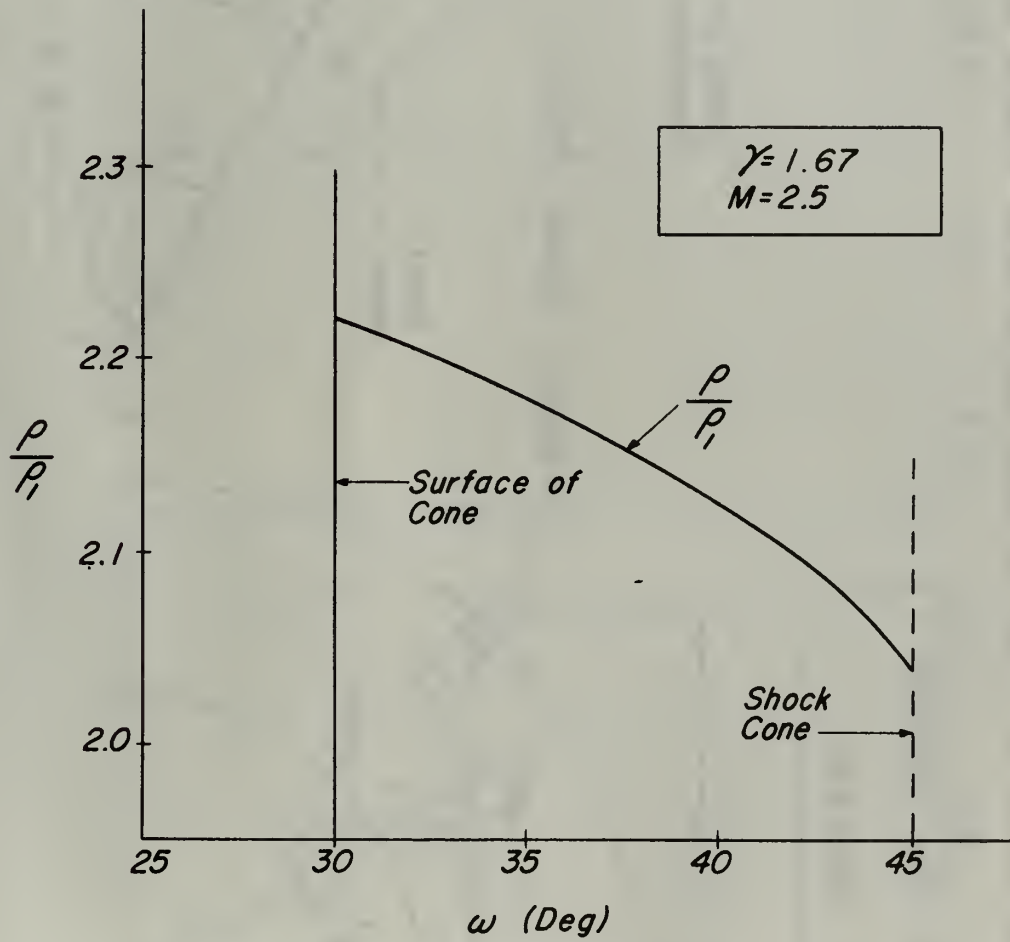

Fig. 6

**GEOMETRY OF THE CONICAL  
FLOW PROBLEM**

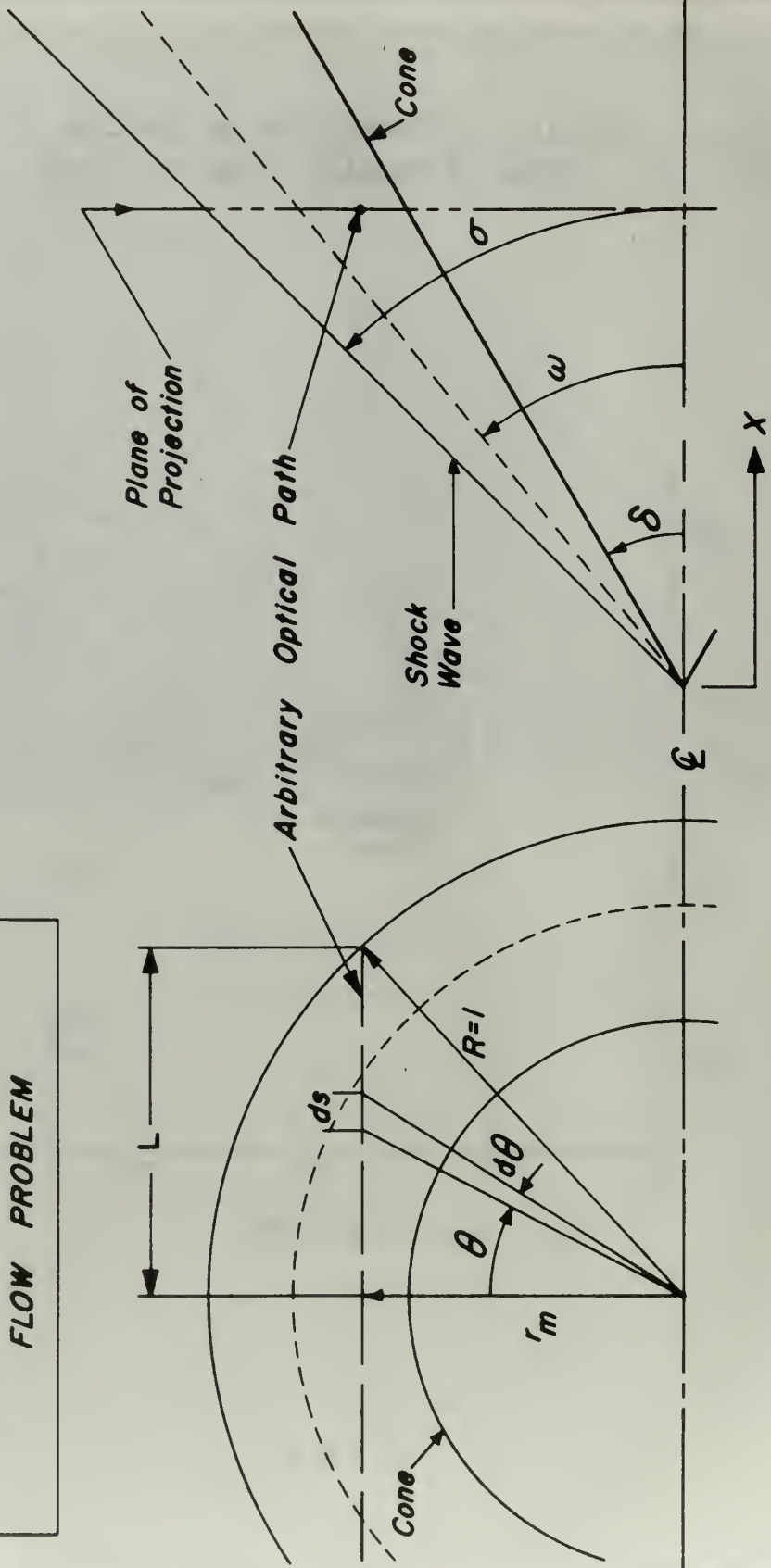
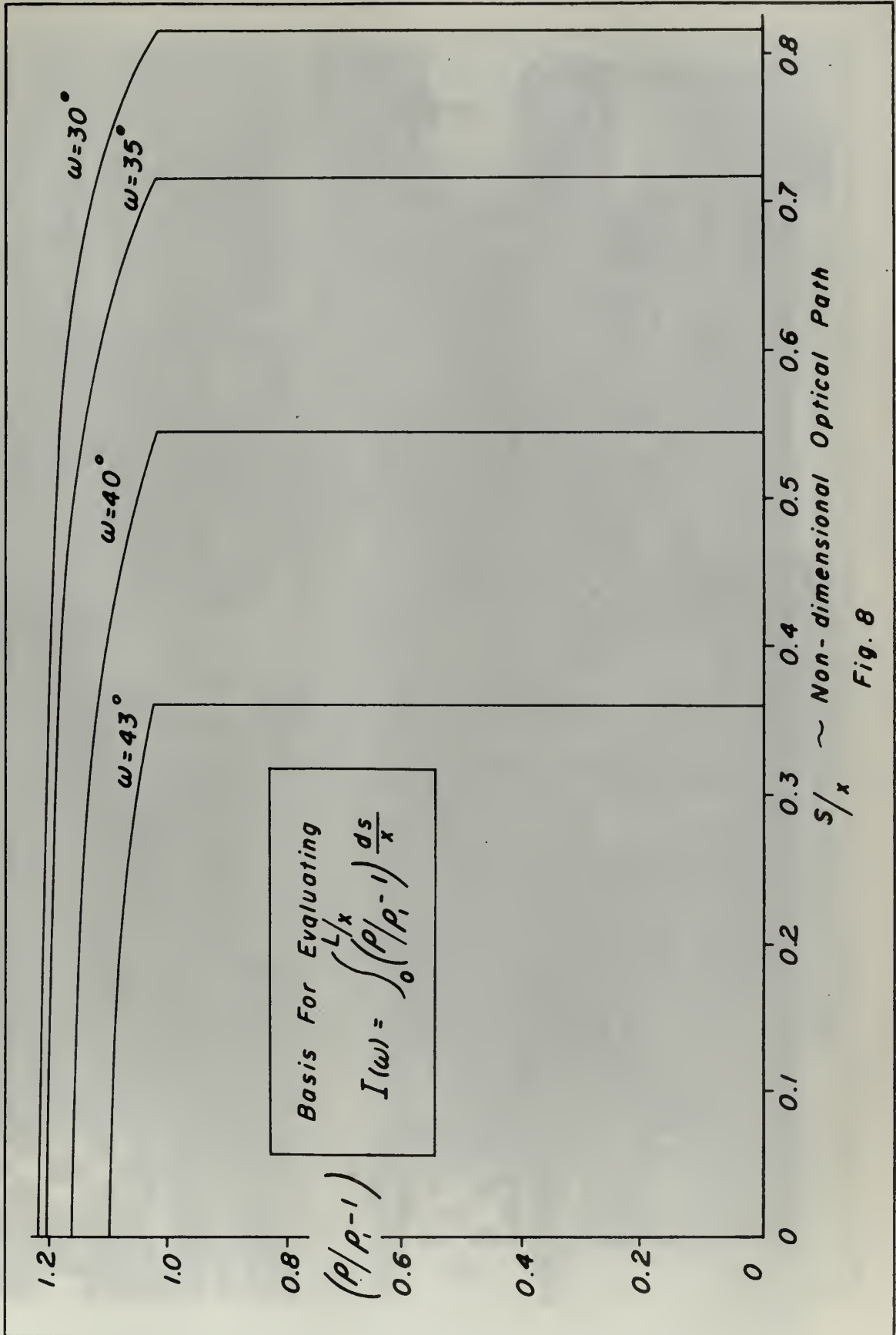

Fig 7



$S/x \sim$  Non-dimensional Optical Path

Fig. 8

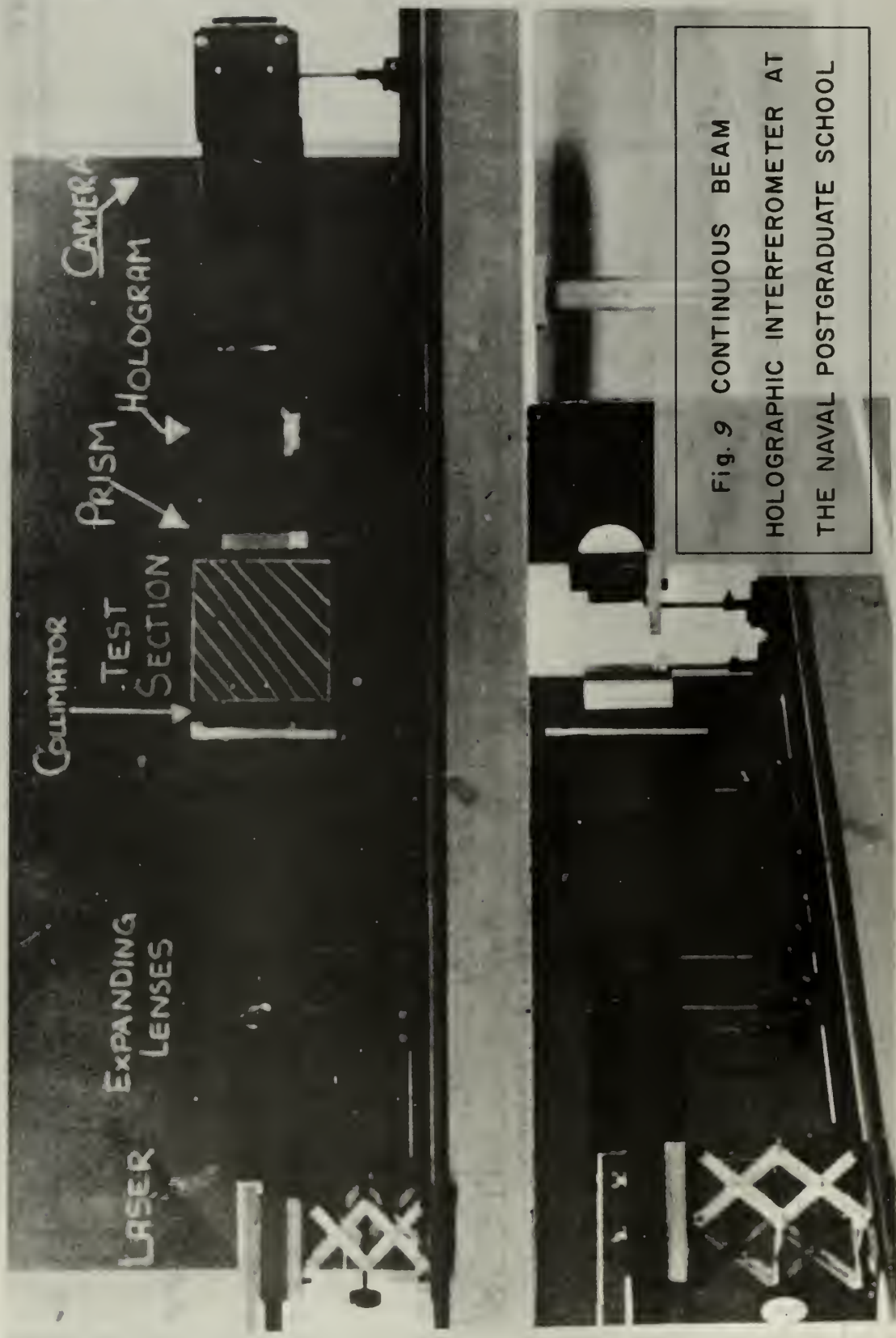

Fig. 9 CONTINUOUS BEAM  
HOLOGRAPHIC INTERFEROMETER AT  
THE NAVAL POSTGRADUATE SCHOOL



*INTERFEROGRAM OF 40° CONE AT MACH 2.7;  
INFINITE AND FINITE FRINGE.  
DOTS REPRESENT VARIABLE DENSITY  
SOLUTION OF FRINGE PREDICTION.*

*Fig. 10*





*HEATED ROD*

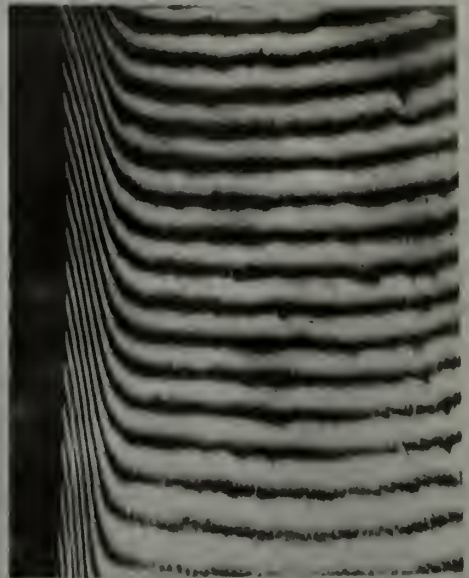

*HEATED PLATE*



*FLAME*

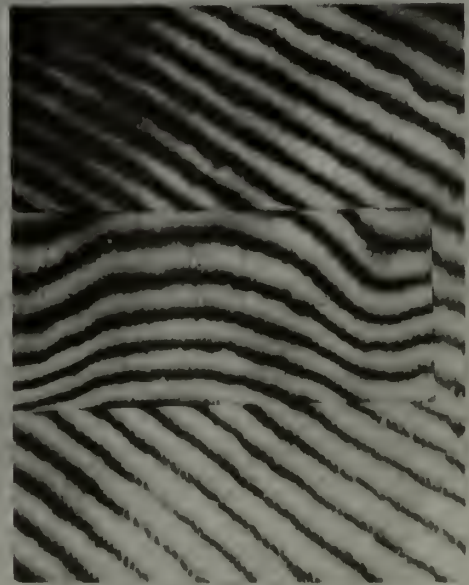

*SLIDE GLASS*

*Fig.11 DARK FIELD INTERFEROGRAMS  
OF VARIOUS SUBJECTS*

## BIBLIOGRAPHY

- Ashkenas, H. I., and Bryson, R. E., "Design and Performance of a Simple Interferometer for Wind-Tunnel Measurements," Journal of Aeronautical Sciences, 18 (1951), p. 82.
- Bennett, F. D., Carter, W. C., and Bergdolt, V. E., "Interferometric Analysis of Airflow about Projectiles in Free Flight," Journal of Applied Physics, 23 (1952), pp. 453-469.
- Brooks, R. E., Heflinger, L. O., and Wuerker, R. F., "Interferometry with a Holographically Reconstructed Comparison Beam," Applied Physics Letters, (Nov. 1, 1965).
- Brooks, R. E., Heflinger, L. O., Wuerker, R. F., and Briones, R. A., "Holographic Photography of High Speed Phenomena with Conventional and Q-Switched Ruby Lasers," Applied Physics Letters, 7 (Aug. 15, 1965), p. 92.
- Gabor, D., "A New Microscopic Principle," Nature, 161 (May 15, 1948), p. 777.
- Gabor, D., "Microscopy by Reconstructed Wavefronts," Proceedings of the Royal Society, London, A197 (1949), p. 454.
- Giese, J. H., Bennett, F. D., and Bergdolt, V. E., "A Simple Interferometric Test for Conical Flow," Journal of Applied Physics, 21 (1950), pp. 1226-1231
- Heflinger, L. O., Wuerker, R. F., and Brooks, R. E., "Holographic Interferometry," Journal of Applied Physics, 37 (1966), pp. 642-649
- Henderson, A., and Braswell, D. O., "Charts for Conical and Two-Dimensional Oblique Shock Parameters in Helium at Mach Numbers from about 1 to 100," NASA TN-D819
- Horman, M. H., "An Application of Wavefront Reconstruction to Interferometry," Applied Optics, 4 (March 1965), pp. 333-336
- Kohtiao, A., Newton, J., Schwell, H., and Resnick, I., "Hazards and Physiological Effects of Laser Radiation," Annals of The New York Academy of Sciences, 122 (Mar. 28, 1965), pp. 777-779.
- Leith, E., and Upatnieks, "Reconstructed Wavefronts and Communications Theory," Journal of the Optical Society of America, 52 (1962), p. 1123.
- Leith, E., and Upatnieks, "Wavefront Reconstruction with Continuous Tone Objects," Journal of the Optical Society of America, 53 (1963), p. 1377

BIBLIOGRAPHY (CONTINUED)

Lengyel, B. A., Lasers (New York: John Wiley and Sons, Inc., 1962).

Liepmann, H. W., and Roshko, A., Elements of Gas Dynamics (London: John Wiley and Sons, Inc., 1957).

Lytel, A., ABC's of Lasers and Masers (Indianapolis: Howard W. Sams and Co., 1963).

Manoranjan De, and Sevigny, L., "Three Beam Holography," Applied Physics Letters, 10 (Feb. 1, 1967), p. 78.

Shapiro, A. H., The Dynamics and Thermodynamics of Compressible Fluid Flow (New York: The Ronald Press Co., 1954), Chapter 17.

Smith, W. V., and Sorokin, P. P., The Laser (New York: McGraw-Hill Book Co., 1966).

✓ Stetson, K. A., and Powell, R. L., "Hologram Interferometry," Journal of the Optical Society of America, 56 (Sept. 1966), p. 1161.

Stroke, G. W., An Introduction to Coherent Optics and Holography (New York: Academic Press, Inc., 1966).

Tolansky, S., An Introduction to Interferometry (New York: Longmans, Green and Co., 1955) p.115.

INITIAL DISTRIBUTION LIST

	No. Copies
1. Defense Documentation Center Cameron Station Alexandria, Virginia 22314	20
2. Library Naval Postgraduate School Monterey, California 93940	2
3. Commander, Naval Air Systems Command Department of the Navy Washington, D. C. 20360	1
4. Professor A. E. Fuhs Department of Aeronautics Naval Postgraduate School Monterey, California 93940	6
5. LT James H. Holds, USN 21 W. Goguac Street Battle Creek, Michigan 49015	2
6. Dr. L. O. Heflinger TRW Systems Physical Electronics Laboratory One Space Park Redondo Beach, California 92078	1
7. Professor R. E. Reichenbach Department of Aeronautics Naval Postgraduate School Monterey, California 93940	1
8. Department of Aeronautics Naval Postgraduate School Monterey, California 93940	2
9. Dr. W. F. Koehler Dean of Programs Naval Postgraduate School Monterey, California 93940	1



## Security Classification

## DOCUMENT CONTROL DATA - R&amp;D

(Security classification of title, body of abstract and indexing annotation must be entered when the overall report is classified)

1. ORIGINATING ACTIVITY (Corporate author) Naval Postgraduate School		2a. REPORT SECURITY CLASSIFICATION Unclassified	
		2b. GROUP N/A	
3. REPORT TITLE Aeronautical Applications of Holographic Interferometry			
4. DESCRIPTIVE NOTES (Type of report and inclusive dates) Thesis			
5. AUTHOR(S) (Last name, first name, initial) Holds, James H.			
6. REPORT DATE June 1967		7a. TOTAL NO. OF PAGES 44	7b. NO. OF REFS 22
8a. CONTRACT OR GRANT NO. N/A		8a. ORIGINATOR'S REPORT NUMBER(S) N/A	
8b. PROJECT NO. N/A			
8c. N/A		8b. OTHER REPORT NO(S) (Any other numbers that may be assigned this report) N/A	
8d. N/A		This document has been approved for public release and sale; its distribution is unlimited.	
10. AVAILABILITY/LIMITATION NOTICES <del>This document is subject to special export controls and each transmittal to foreign government or foreign nationals may be made only with prior approval of the U. S. Naval Postgraduate School.</del> <span style="float: right;">New 5/70</span>			
11. SUPPLEMENTARY NOTES N/A		12. SPONSORING MILITARY ACTIVITY Commander, Naval Air Systems Command Navy Department Washington, D. C.	
13. ABSTRACT  The advent of holography and the laser as an extremely intense, coherent light source has opened new dimensions in interferometric techniques. Precision optics are not required, alignment is not a critical factor, and three-dimensional interferograms of a flow field are obtainable. These are only a few of the advantages that stand out over present day interferometers. A brief outline of the holographic interferometric process and its capabilities is presented here. A detailed exposition of the continuous reconstruction beam technique is given from experience gained with such a device in the Department of Aeronautics of the Naval Postgraduate School. (U)			

14.

KEY WORDS

LINK A

LINK B

LINK C

ROLE

WT

ROLE

WT

ROLE

WT

INTERFEROMETRY

HOLOGRAM

LASER APPLICATION













thesH6807

Aeronautical applications of holographic



3 2768 002 06890 0

DUDLEY KNOX LIBRARY