



Calhoun: The NPS Institutional Archive

Theses and Dissertations

Thesis Collection

2004

Structural loading of cross deck connections for trimaran vessels / by Jason L. Rhoads.

Rhoads, Jason L.

<http://hdl.handle.net/10945/11043>



Calhoun is a project of the Dudley Knox Library at NPS, furthering the precepts and goals of open government and government transparency. All information contained herein has been approved for release by the NPS Public Affairs Officer.

Dudley Knox Library / Naval Postgraduate School
411 Dyer Road / 1 University Circle
Monterey, California USA 93943

<http://www.nps.edu/library>

Structural Loading of Cross Deck Connections for Trimaran Vessels

by

Jason L. Rhoads

B.S. Nuclear Engineering
B.S. Materials Science & Engineering
University of California, Berkeley, 1995

Submitted to the Department of Ocean Engineering and the Department of Civil and Environmental Engineering in Partial Fulfillment of the Requirements for the Degrees of

Naval Engineer

and

Master of Science in Civil and Environmental Engineering

at the

Massachusetts Institute of Technology

June 2004

© 2004 Jason L. Rhoads. All rights reserved.

The author hereby grants to MIT and the U.S. Government permission to reproduce and to distribute publicly paper and electronic copies of this thesis document in whole or in part.

Signature of Author

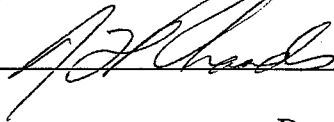

Department of Ocean Engineering and the
Department of Civil and Environmental Engineering
May 7, 2004

Certified by

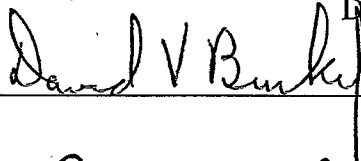

David V. Burke, Senior Lecturer
Department of Ocean Engineering
Thesis Supervisor

Certified by

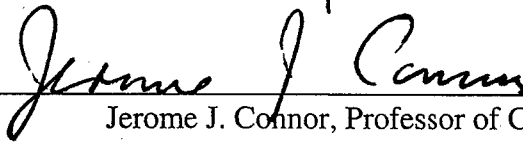

Jerome J. Connor, Professor of Civil and Environmental Engineering
Department of Civil and Environmental Engineering
Thesis Reader

Accepted by



Heidi Nepf, Associate Professor of Civil and Environmental Engineering
Chairman, Department Committee on Graduate Studies
Department of Civil and Environmental Engineering

Accepted by

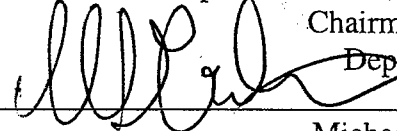

Michael Triantafyllou, Professor of Ocean Engineering
Chairman, Department Committee on Graduate Studies
Department of Ocean Engineering

DISTRIBUTION STATEMENT A
Approved for Public Release
Distribution Unlimited

20040830 035

Page Intentionally Left Blank

Structural Loading of Cross Deck Connections for Trimaran Vessels

by
Jason L. Rhoads

Submitted to the Department of Ocean Engineering and the Department of Civil and Environmental Engineering in Partial Fulfillment of the Requirements for the Degrees of

Naval Engineer

and

Master of Science in Civil and Environmental Engineering

ABSTRACT

This work investigates the fundamental relationships of wave loading on cross deck structures for trimaran vessels. In contrast with a monohull ship, trimaran vessels experience several possible structural loading cases including: longitudinal bending, transverse bending, torsional bending, spreading and squeezing of hulls, inner and outer hull slam pressures, wet deck slam pressures, loading from ship's motions, and whipping of slender hulls. This work investigates wave loading cases that result in transverse and torsional bending of the cross deck structure.

The wave loading cases investigated include: side hull troughing and cresting in longitudinal waves, side hull torsion in longitudinal waves, and transverse hogging and sagging. For each of these load cases, a design load using a fully statistical sea state was derived using an analytical model of a trimaran represented by rigidly connected box barges. The design loadings with a reliability index of 5 for almost 500 trimaran configurations were calculated varying main hull length, side hull length, side hull transverse placement, and side hull longitudinal placement. The design loadings were curve fit to a fourth order polynomial in the three independent variables.

The load predictions of the analytical box model of a trimaran were applied to a trimaran vessel with a realistic hull form using the finite element ship structural analysis program MAESTRO. Given the number of approximations and assumptions in the analytical model, the forces predicted by analytical model agreed closely with the finite element model's results.

The fitted curve of design loadings allows an initial design stage loading estimate for cross deck structural loading, given general characteristics of length and spacing of a trimaran's hulls. This estimate of structural loading combined with other characteristics of good trimaran design including stability, roll, and resistance characteristics will aid in optimizing an overall trimaran ship design.

Thesis Supervisor: David V. Burke
Title: Senior Lecturer, Department of Ocean Engineering

Thesis Reader: Jerome J. Connor
Title: Professor of Civil and Environmental Engineering

Table of Contents

Chapter 1	Introduction.....	9
1.1	Thesis and general approach.....	10
1.2	Background.....	11
Chapter 2	General Trimaran Characteristics.....	12
Chapter 3	Theory.....	14
3.1	Wave Loading Cases.....	14
3.1.1	Longitudinal Bending.....	14
3.1.2	Coincident Side Hull Troughing and Cresting in Longitudinal Waves.....	15
3.1.3	Side Hull Torsion in Longitudinal Waves.....	16
3.1.4	Transverse Bending.....	18
3.1.5	Other Possible Loading Cases.....	19
Chapter 4	Analysis Tools.....	21
4.1	Analytical Trimaran Model.....	21
4.1.1	Analytical Model Parts.....	22
4.2	Finite Element/ MAESTRO Analysis.....	41
4.2.1	Refined Finite Element MAESTRO Model.....	41
4.2.2	Statistically Significant Waves for the MAESTRO Model.....	44
4.2.3	MAESTRO Structural Failure Modes.....	47
4.2.4	MAESTRO Model Organization.....	49
4.2.5	MAESTRO Verification of Analytical Trimaran Model Predicted Forces.....	51
Chapter 5	Results.....	52
5.1	Statistical Analysis of Analytical Trimaran Model Using JMP.....	52
5.1.1	Analytical Model Results for Longitudinal Side Hull Troughing.....	53
5.1.2	Analytical Model Results for Longitudinal Side Hull Cresting.....	55
5.1.3	Analytical Model Results for Longitudinal Positive Phase Twisting.....	57
5.1.4	Analytical Model Results for Longitudinal Negative Twisting.....	59
5.1.5	Analytical Model Results for Transverse Sagging.....	61
5.1.6	Analytical Model Results for Transverse Hogging.....	62
5.2	Comparison and Discussion of Analytical and MAESTRO Results.....	63
Chapter 6	Conclusions.....	65
Chapter 7	Recommendations for Future Work.....	66
	List of References.....	67
	Appendix A. MathCAD Analytical Model.....	71

Appendix B. MathCAD Analytical Results Tables.....	83
Appendix C. Wave Height Matching Reliability Index of Five.....	109
Appendix D. Fit Parameters for Analytical Thesis Model	111
Appendix E. Comparison of Results for Longitudinal Troughing.....	117
Appendix F. Comparison of Results for Longitudinal Cresting	127
Appendix G. Comparison of Results for Longitudinal Positive Twisting	137
Appendix H. Comparison of Results for Longitudinal Negative Twisting.....	147
Appendix I. Comparison of Results for Transverse Hogging.....	157
Appendix J. Comparison of Results for Transverse Sagging.....	167

List of Figures

Figure 1 – RV Triton [2].....	9
Figure 2 – Longitudinal Cresting with Side Hulls Aft.....	15
Figure 3 – Longitudinal Cresting with Side Hulls Amidships.....	15
Figure 4 – Longitudinal Troughing with Side Hulls Aft.....	16
Figure 5 – Longitudinal Troughing with Side Hulls Amidships.....	16
Figure 6 – Negative Phase Twisting with Side Hulls Aft.....	17
Figure 7 – Positive Phase Twisting with Side Hulls Aft.....	17
Figure 8 – Twisting with Side Hulls Amidships.....	17
Figure 9 – Transverse Sagging.....	18
Figure 10 – Transverse Hogging.....	19
Figure 11 – Analytical Model Coordinate System.....	28
Figure 12 – Transverse Sagging Applying Upward Buoyant Force on Cross Structure.....	33
Figure 13 – Positive Phase Twisting with Side Hulls Aft.....	34
Figure 14 – Analytical Model Position of Calculated Forces.....	35
Figure 15 – Profile View of 100m Trimaran Balanced on a Wave of Long Wavelength.....	38
Figure 16 – Starboard Bow Perspective of a MAESTRO Trimaran Half Model.....	42
Figure 17 – Aft Body Plan View of a MAESTRO Trimaran Half Model with Water Line.....	43
Figure 18 – Port Bow Perspective of a MAESTRO Trimaran Half Model.....	43
Figure 19 – Reliability Index Wave Heights of 5 verses Wavelength.....	46
Figure 20 – Organizational Structure of a General MAESTRO Model [20].....	49
Figure 21 – Organization for the Specific MAESTRO Model Analyzed.....	50
Figure 22 – MAESTRO Model Organization of Trimaran Cross-Deck Structure.....	50
Figure 23 – Longitudinal Wave Side Hull Troughing Independant Variable Interaction.....	53
Figure 24 – Longitudinal Wave Side Hull Cresting Independant Variable Interaction.....	55
Figure 25 – Longitudinal Wave Side Hull Positive Twisting Independant Variable Interaction.....	57
Figure 26 – Longitudinal Wave Side Hull Negative Twisting Independant Variable Interaction.....	59
Figure 27 – Transverse Sagging Wave Side Hull Independant Variable Interaction.....	61

List of Tables

Table 1 – Principal characteristics of UCL trimaran studies [1].....	12
Table 2 – Additional characteristics of UCL trimaran studies.....	13
Table 3 – Structural Loading from sections 3.1.2, 3.1.3, and 3.1.4.....	21
Table 4 – Relevant Trimaran Parameters Affecting Design Loading.....	21
Table 5 – Joint Probability Mass Table of Significant Wave Height and Period.....	22
Table 6 – Joint Probability Mass Table of Significant Wave Height and Period.....	23
Table 7 – Joint Probability of True Wave Height and Period (3-11 second periods).....	25
Table 8 – Joint Probability of True Wave Height and Period (12-22 second periods).....	26
Table 9 – Deep Water Wavelengths.....	27
Table 10 – Parameters varied for Trimaran Design Space.....	39
Table 11 – Parameters Held in Fixed Relations for Trimaran Design Space.....	39
Table 12 – Particular Dimensions of Real Ship Model Used.....	41
Table 13 – Analytical Model Predictions for Comparison to MAESTRO.....	42
Table 14 – Equivalent Wave Height for Reliability Index of 5.....	45
Table 15 – Panel Failure Modes.....	47
Table 16 – Frame Failure Modes.....	47

Table 17 – Girder Failure Modes.....	47
Table 18 – Adequacy Parameters with analytically Predicted Forces (Longitudinal Troughing) 63	
Table 19 – Adequacy Parameters with MAESTRO Wave Balance (Longitudinal Troughing)... 63	
Table 20 – Structural Loading from Sections 3.1.2, 3.1.3, and 3.1.4	64
Table 21 – Relevant Trimaran Parameters Affecting Design Loading.....	64

List of Terms

B_m	main hull's beam
B_s	side hull's beam
FB_{lg}	vertical force on cross-structure in longitudinal waves (troughing and cresting)
FB_{tr}	vertical force in transverse waves (transverse hogging/sagging)
F_m	main hull's freeboard (also side hull freeboard)
g	gravitational constant
H_s	observed significant wave height
h_w	actual wave height
H_{wave_lg}	longitudinal wave amplitude
H_{wave_tr}	transverse wave amplitude
L_m	main hull's length
L_s	side hull's length
MB_{lg}	moment on cross-structure in longitudinal waves (longitudinal twisting)
V_{still}	original still water displacement
p	index of the wave height
p_{Ray}	Rayleigh probability distribution
q	index of the wavelength
t	index of the observed significant wave height
T	wave period
T_m	main hull's draft
$Trim_{still}$	original still water trim (assumed to be zero)
T_s	side hull's draft
x	longitudinal position
X_{cf}	longitudinal position of the entire ship's center of floatation
X_s	longitudinal position of the side hull with respect to main hull amidships
y	transverse position
Y_s	transverse position of the side hull with respect to main hull centerline
ΔT	change in heave of the ship due to the wave
Θ_{pitch}	change in pitch of the ship due to the longitudinal wave
λ	wavelength of the wave
ϕ	phase of the wave applied for each loading condition

Page Intentionally Left Blank

Chapter 1 Introduction

Over recent decades a growing demand for higher speed ships has led to the development of several new hull form concepts. These hull forms include catamarans, surface effects (SES) ships, small waterplane twin-hull (SWATH) ships, pentamaran, and trimaran ships to name a few. Of these 'new' hull forms the multi-hull vessel's origins can be traced to back several centuries to many seagoing peoples with outrigger canoes. In more recent times the multi-hull ships have been used in several racing, pleasure, and commercial vessels.

The benefits of the trimaran hull form have been studied extensively over the past several years at the University College London (UCL) [1]. In 2000 the RV TRITON, Figure 1 below, a trimaran demonstrator project for the United Kingdom's Royal Navy, was launched to test the trimaran hull form [2].

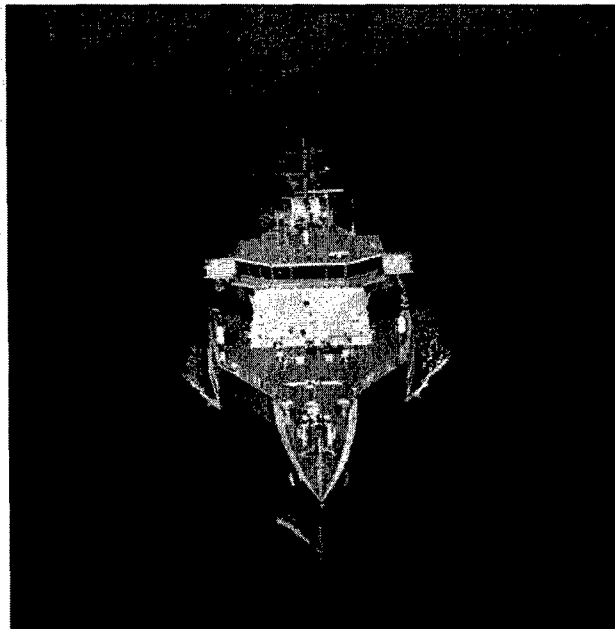

Figure 1 – RV Triton [2]

While much work in the area of trimaran hull form design has been accomplished by the UCL studies, the structural loading experienced by the cross-deck structure of the trimaran hull form is still largely unknown. Classification societies such as the American Bureau of Shipping (ABS) [3] or Det Norske Veritas (DNV) [4] currently have design codes for a traditional monohull's design loadings in terms of the ship's relevant dimensions and a sea-state coefficient dependent on ships dimensions to provide sufficient design margin for the life of a ship.

However, currently no such design codes exists for trimarans in general or specifically their cross-deck structures. The goal of this work is to be able to state similar design loadings based on the relevant parameters of a trimaran ship.

The trimaran's structural loading will depend strongly on the longitudinal extent as well as the longitudinal and transverse location of the outer hulls. These parameters of the outer hulls, by necessity, depend on the operational requirements and uses of the ship. In contrast with a conventional mono-hull ship, the structural loading of the trimaran potentially involves several additional loading cases not experienced by mono-hull ships. These loading cases may include longitudinal bending, transverse bending, torsional bending, spreading and squeezing of hulls, inner and outer hull slam pressures, wet deck slam pressures, loading from ship's motions, and whipping of slender hulls.

1.1 Thesis and general approach

Of the above-mentioned loading cases this work will focus on the structural loading in the longitudinal, transverse, and torsional wave loading cases that affect the cross-structure between the main and outer hulls of a trimaran. As previously mentioned, the loading of the cross structure between the hulls of a trimaran will depend strongly on the longitudinal extent and location of the trimaran's side hulls. This work will quantify the effects of various outer hull placements and sizes on the trimaran's cross-deck structural loading. Once the structural loading as functions of placement and size are determined, this information could be used in conjunction with other trimaran design parameters such as stability, roll, and resistance characteristics to optimize an overall trimaran ship design.

The approach for this study will be to first determine analytical approximations to the trimaran cross-deck structural loading using simple and symmetric box-type hull shapes for each of the three hulls. These analytical solutions will account for worst-case statistical sea state for various outer hull placement and size. Next these analytical approximations will be compared with quasi-finite element solutions obtained using the ship structural design program Method for Analysis Evaluation and Structural Optimization (MAESTRO) on hull forms more closely resembling actual hulls of trimarans. Comparison of these two approaches will provide an estimate the validity of the analytical approximations for various combinations of sea state and different trimaran configurations of placement and size of the outer hulls.

1.2 Background

The openly available previous work in the area of trimaran structural design to date has been fairly limited in scope. In general, the previous studies have assumed a worst case deterministic loading level in a few loading cases for specific designs of trimarans. The foci of these studies have been to investigate the cross-structure contribution to primary hull bending and transverse cross-structure bending in rolling conditions. The results of these studies are included in references [5] through [10].

The first of these studies examined the contribution from the side hull and cross deck structure to overall ship structural performance in longitudinal bending for both hogging and sagging [5]. The next study involving trimaran structures focused on performing a detailed structural point design including scantling sizes to estimate the structural weight fraction of a specific frigate-sized trimaran as compared to a monohull [6]. The third study again investigated the contribution of side hull and cross deck structure to the resistance of primary hull bending in hogging and sagging [7]. The next study [8] involved a reevaluation of the contribution to primary bending resistance from the side hulls and cross structure contained in references [5] and [7] with a more refined model of the trimaran hull form.

While references [5] through [8] dealt primarily with longitudinal loading in primary bending, reference [9] investigated the trimaran's structural behavior under transverse loading due to rolling the trimaran's side hulls to complete submergence or broach. The last study in trimaran structural design [10] investigates low weight alternatives to cross structure in loading condition cause by a ship rolling its hulls to complete submergence or broach.

The previous work on trimaran structural design to this point has only scratched the surface of the possible relevant structural design issues of this new hull form. While the previous work has sought to characterize a few deterministic loading scenarios for a small range of ships, this work will characterize the structural wave loading of the trimaran's cross-deck structure subjected to a statistical sea state for a variety of trimaran configurations and sizes.

Chapter 2 General Trimaran Characteristics

The trimaran hull form has been studied extensively over the past several years at the University College London. The results of these studies have produced several variants of the trimaran ship. Some of the relevant characteristics of those designs are shown below in Table 1.

Table 1 – Principal characteristics of UCL trimaran studies [1]

	Small Support Vessel	Offshore Patrol Vessel	RV TRITON	Fast Ferry	Canadian Ferry	Corvette	ASW Frigate	ASW Frigate	AAW Destroyer	Cruise Liner	LPH	Small Carrier
Displacement (tonne)	234	514	1117.6	1130	1350	1777	4200	4300	4978	9050	11850	16657
Extreme Length (m)	61.04	78.8	98	105	120	112	154.7	156.8	168.6	192	191.5	231.6
Extreme Beam (m)	10.85	13.7	22.5	19.2	25	20	27.5	25.9	25	28	40	43
Depth (m)	4.3	8.5	9	8.5	8	8.85	10.23	12.1	11.1	13.2	23.35	23.5
Main Hull LWL (m)	59.8	76.8	91	99	115	106.7	148.7	149.8	151.3	178.3	177.2	220
Main Hull Beam WL (m)	4.2	4.2	6.848	6.8	6.5	8.5	10.4	10.8	10.8	13	13.5	14.5
Main Hull Draft WL (m)	2.1	3.4	3.2	3.4	3.2	4.25	5.2	5.3	4.8	6.4	8.74	8
Side Hull Displacement	4.20%	3.10%	3.70%	4.00%	3.80%	4.30%	5.50%	3.70%	4.70%	3.00%	5.00%	6.80%
Side Hull LWL (m)	19.9	28	34.2	35	30	50	36	56.9	65	71.3	65.2	82
Side Hull Beam WL (m)	1.06	0.74	1.45	1.5	2	2.7	3	2	2.5	2.8	3.65	4
Side Hull Draft (m)	0.9	2.1	2.31	2	1.5	1.35	3.6	2.8	2.7	2.6	4.37	6.5
Max Speed (knots)	25	25	20	38	36	30	28	28	28	26	18	27
Ps (MW)	2.14	4.3	4	20	20	20	24	26	29	31.5	16.8	70

The general form of the trimaran in these balanced trimaran ship designs is determined by several factors including stability, roll, and resistance characteristics of a trimaran ship. In general the length of the side hulls is determined by intact and damaged stability requirements [1]. The motion characteristics for trimarans have been examined [1]. Another study indicates that outer hull waterplane area strongly affects roll motion [11]. Favorable resistance characteristics of trimaran outer hull placement have also been studied [12].

From the trimaran characteristics of the UCL designs in Table 1, other important characteristics of balanced trimaran ship designs were calculated or derived with the results shown below in Table 2.

Table 2 – Additional characteristics of UCL trimaran studies

	Small Support Vessel	Offshore Patrol Vessel	RV TRITON	Fast Ferry	Canadian Ferry	Corvette	ASW Frigate	ASW Frigate	AAW Destroyer	Cruise Liner	LPH	Small Carrier
Main Hull Relations												
Main Hull L/B	14.24	18.29	13.29	14.56	17.69	12.55	14.30	13.87	14.01	13.72	13.13	15.17
Main Hull B/T	2.00	1.24	2.14	2.00	2.03	2.00	2.00	2.04	2.25	2.03	1.54	1.81
Main Hull D/T	2.05	2.50	2.81	2.50	2.50	2.08	1.97	2.28	2.31	2.06	2.67	2.94
Main-Side Hull Relations												
Side/Main Hull L/L	0.33	0.36	0.38	0.35	0.26	0.47	0.24	0.38	0.43	0.40	0.37	0.37
Side/Main Hull T/T	0.43	0.62	0.72	0.59	0.47	0.32	0.69	0.53	0.56	0.41	0.50	0.81
Side/Main Hull B/B	0.25	0.18	0.21	0.22	0.31	0.32	0.29	0.19	0.23	0.22	0.27	0.28
Side /Main hull y/B	1.17	1.54	1.54	1.30	1.77	1.02	1.18	1.11	1.04	0.97	1.35	1.34
Side Hull Relations												
Side Hull L/B	18.77	37.84	23.59	23.33	15.00	18.52	12.00	28.45	26.00	25.46	17.86	20.50
Side Hull B/T	1.18	0.35	0.63	0.75	1.33	2.00	0.83	0.71	0.93	1.08	0.84	0.62

The trimaran characteristics shown in Table 2 will be used later in section 4.1 for development of the analytical trimaran model to set proper limits governing the range of characteristics for investigation of the applicable trimaran design space.

Chapter 3 Theory

The most accurate way to determine a ship's structural loading is to perform a fully dynamic analysis of the ship in a completely statistical sea state accounting for added mass and damping of the ocean in relation with the ship's motions with provisions to add the effects of the ship's forward speed and heading. However, even with today's advanced computational capabilities, this level of analysis is prohibitive for an investigation of the basic structural loading attributes of a new hull form such as the trimaran. Therefore, the emphasis of this work will study a static analysis of the wave loading of a trimaran, which often is sufficient as a first estimate of structural loading [13].

The cross-deck structural wave loading of the trimaran is affected by two major considerations: the longitudinal and transverse placement of the outer hulls, and the waterplane area (length and beam) of the outer hulls. How each of these outer hull characteristics affect each loading case is detailed below.

3.1 Wave Loading Cases

3.1.1 Longitudinal Bending

The longitudinal bending loading of a traditional monohull ship is generally characterized by two loading cases: hogging and sagging. Similarly, the longitudinal bending loads exerted on the trimaran's cross-deck structure might be expected to be described in terms of the hogging and sagging cases. However, in the case of a trimaran there can be two cases of hogging or sagging. These cases include hogging or sagging of the main hull as well as that of the outer hulls. Longitudinal bending loads in hogging and sagging of the side hulls was investigated in [8] and found to be virtually insignificant. While hogging and sagging of the main hull must be designed for in the overall structural design of a trimaran, the primary bending conditions of the main hull of a trimaran is not significantly different than that of a conventional monohull ship. Additionally, the contribution to resistance of primary bending of the ship due to the addition of the trimaran's cross-structure was investigated with the results in references [5] through [8], and hence the main hull longitudinal hogging and sagging problem is not further investigated in depth in this work.

3.1.2 Coincident Side Hull Troughing and Cresting in Longitudinal Waves

While the longitudinal bending forces incurred from the side hulls experiencing a wave of a wavelength that can produce hogging or sagging on the side hulls are not significant [8], the possibility of the wave crest or trough coinciding with the side hull length can create a significant vertical structural loading. This loading is due to the coincidence of location of the side hulls with a trough or a crest of a wave. While specific wavelengths can create a significant vertical force on the side hulls due to broaching or immersing the side hulls, the overall structural response of the entire ship is minimal compared with the wavelengths associated with primary bending in the trimaran's main hull hogging or sagging. These conditions are shown below in Figure 2 through Figure 5 with the hulls of the trimaran represented by box barges.

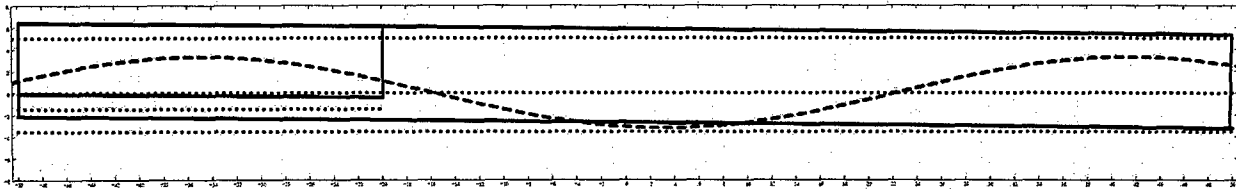

Figure 2 – Longitudinal Cresting with Side Hulls Aft

Figure 2 through Figure 5 show profile views of various possible configurations of coincident side hull troughing and cresting for a trimaran of typical proportions as determined from Table 2. The dotted lines show the still water position of the trimaran and waterline, the dashed line shows the wave, and the solid lines show the trimaran's response to the wave.

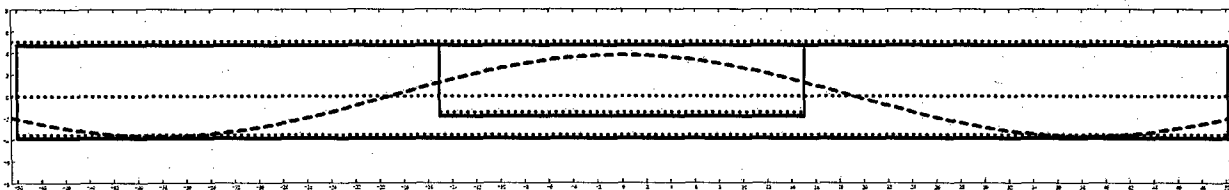

Figure 3 – Longitudinal Cresting with Side Hulls Amidships

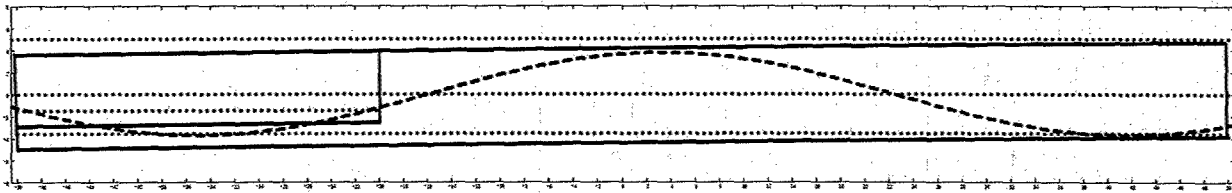

Figure 4 – Longitudinal Troughing with Side Hulls Aft

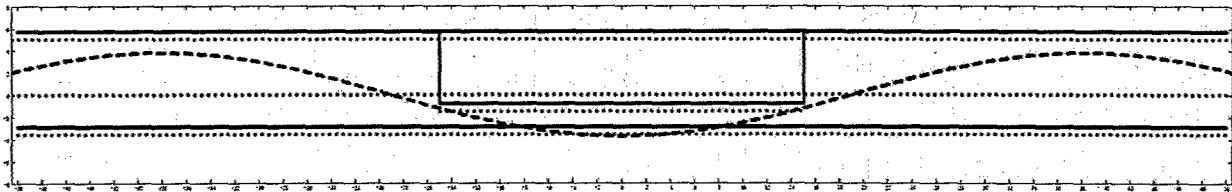

Figure 5 – Longitudinal Troughing with Side Hulls Amidships

In contrast with the traditional primary bending of hogging and sagging, coincident side hull troughing and cresting creates a vertical loading that increases and decreases the contribution of side hull buoyancy. For example, as can be seen in Figure 5 above, the main hull experiences a partial sagging condition, while the trough of the wave drops out from beneath the side hulls creating a vertical downward force on the cross-structure due to the loss of buoyancy of the side hulls. The troughing situation is especially relevant in the case where the outer hulls are relatively short compared to the main hull. The situation is similar for a cresting wave creating an upward vertical force on the outer hulls due to increased immersion and buoyancy.

The coincident side hull troughing and cresting conditions arise from the configuration of the trimaran's side hulls not being the same length as the main hull. Depending on the length of the main and side hulls, the side hulls could experience radical changes in their buoyant support and contribution while the main hull is relatively unaffected from the view point of a traditional primary bending conditions.

3.1.3 Side Hull Torsion in Longitudinal Waves

As with the case of side hull troughing and cresting, the unequal lengths of the hulls introduces a torsional structural loading on the side hull and cross-deck connection which is not

experienced in traditional monohull ship designs. The side hull torsional loading can be seen below in Figure 6 through Figure 8.

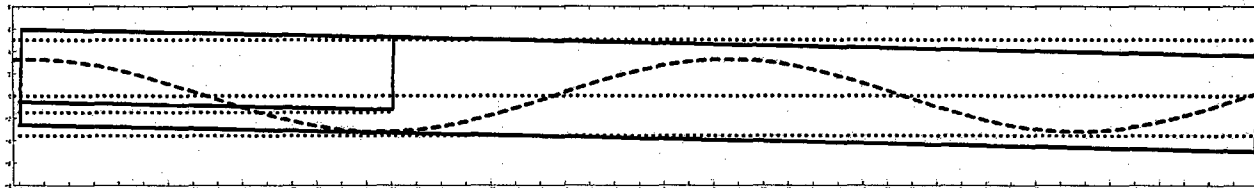

Figure 6 – Negative Phase Twisting with Side Hulls Aft

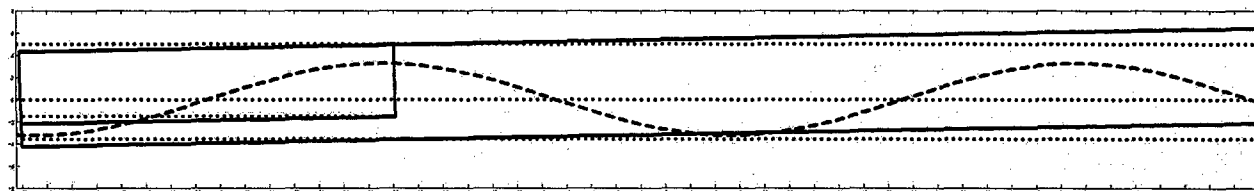

Figure 7 – Positive Phase Twisting with Side Hulls Aft

Figure 6 through Figure 8 show a profile view of various possible configurations of longitudinal torsional loading for a trimaran of typical proportions as determined from Table 2. The dotted lines show the still water position of the trimaran and waterline, the dashed line shows the wave, and the solid lines show the trimaran's response to the wave.

The longitudinal side hull torsion loading arises from similar conditions as that of side hull troughing and sagging. For certain side hull lengths and corresponding wavelengths produced by a particular sea-state, the side hull and cross-deck structure will experience large torsional forces while the main hull is relatively structurally unaffected when compared to its worst case loading conditions.

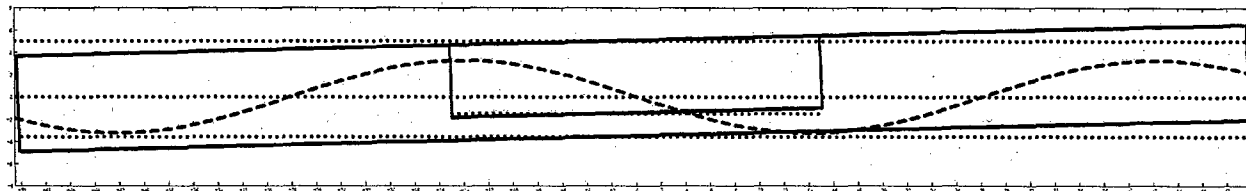

Figure 8 – Twisting with Side Hulls Amidships

3.1.4 Transverse Bending

A traditional monohull ship's structural loading is primarily characterized by the longitudinal bending cases of sagging and hogging. However, the form of the trimaran with its outer stabilizing hulls necessarily involves two new cases of structural loading in transverse bending that is not a concern with a traditional monohull design. These could probably be best described as "transverse hogging" and "transverse sagging." The transverse sagging load case is shown below in Figure 9, while transverse hogging is shown in Figure 10. Figure 9 and Figure 10 show an end view of a typical trimaran ship represented with box hulls.

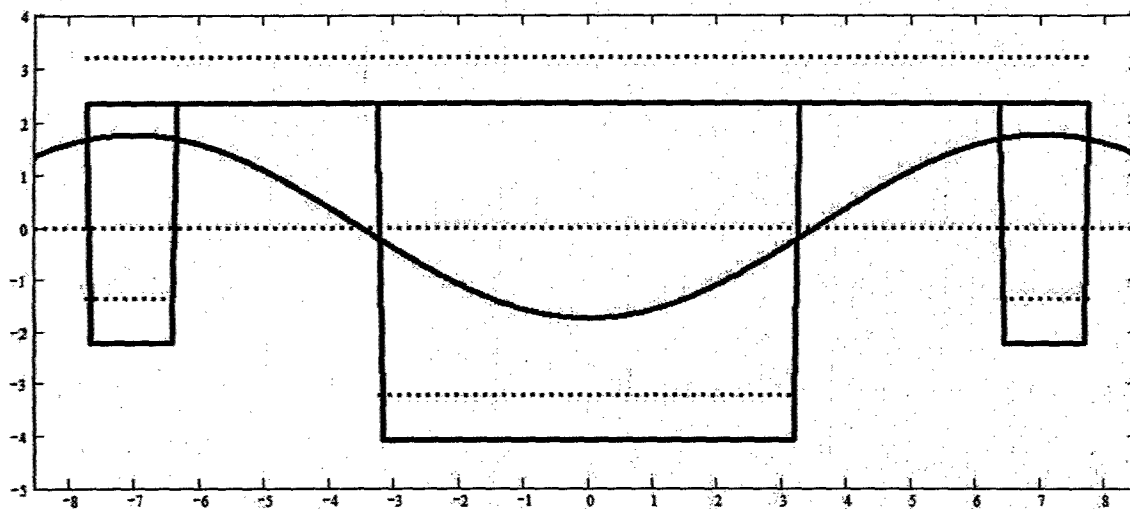

Figure 9 – Transverse Sagging

The dotted lines in the figures show the original still water position of the trimaran, and the heavy lines show the effect on the ship in a transverse beam wave condition. Like the loading conditions previously mentioned, the transverse beam wave condition gives rise to a situation where the side hulls are again gaining or losing buoyancy as compared to the still water case. This change in buoyancy leads to vertical forces applied to the trimaran's cross-deck structure. Depending on the trimaran's outer hull placement and the wavelengths of the beam waves encountered, the side hulls could be completely broached from or immersed in the water.

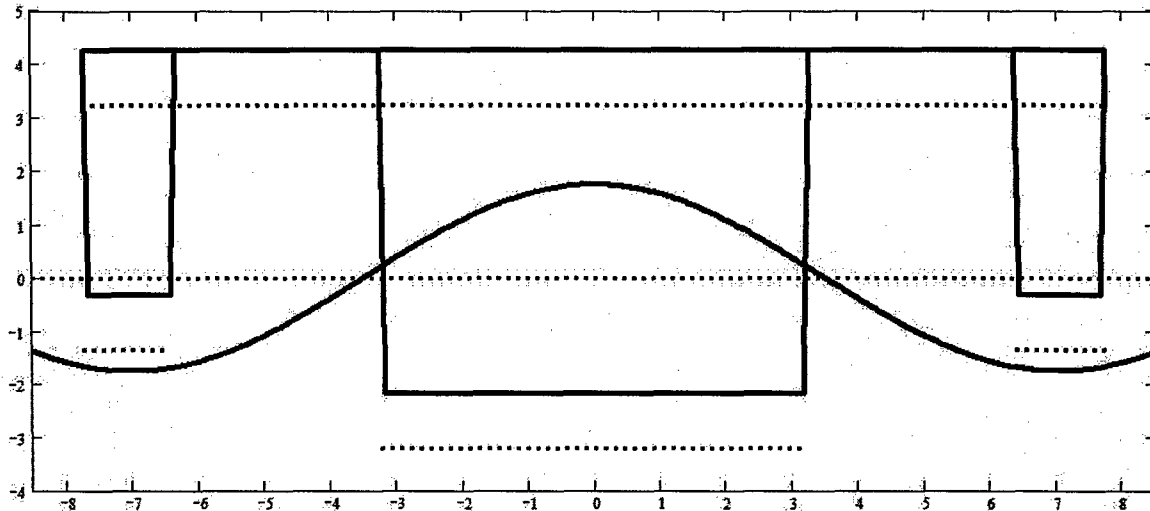

Figure 10 – Transverse Hogging

The “transverse hogging” case in Figure 10 is in reality an unstable condition, since the trimaran in this loading condition will most likely roll until one of its outer hulls rests in the water. However, the transverse hogging has been presented in its unstable condition because it is equivalent to the limiting load case where the outer hull is completely broached from the water.

3.1.5 Other Possible Loading Cases

The structural loading conditions outlined in sections 3.1.2, 3.1.3, and 3.1.4 above only take into account the limited scenarios where the wave front direction is either completely in a head seas or beam seas orientation. Obviously, the majority of the wave fronts experienced by any ship in its service life time will in general be at some oblique angle to the ship’s heading. This oblique angle will contain some of the characteristics of the load cases outline above with additional hydrodynamic forces tending to squeeze and spread the hulls in the transverse direction.

In addition to the transverse hydrodynamic forces, other dynamic loading effects due to the ship’s speed and heading will also need to be accounted for to perform a complete analysis. While these other structural loadings and effects are important to the final structural design and integrity of the completed trimaran ship, the complexity involved in accounting for each effect is

staggering. For the scope of this work, investigating the basic loading parameters, the structural loading conditions of coincident side hull troughing and cresting, side hull longitudinal torsion, and transverse hogging/sagging will be studied as to describe the loading conditions to which a trimaran's cross-deck structure is subjected.

Chapter 4 Analysis Tools

4.1 Analytical Trimaran Model

Over the course of this research almost 40 versions of analytical trimaran models were developed with each version adding successively more functionality and detail. However, the core of the analytical thesis model is that it approximates a trimaran as three rigidly connected “box barges” of appropriate dimensions obtained from Table 2. The analytical model then statically balances the trimaran on a wave and calculates the load forces, as described in section 3.1, applied to the cross-deck structure between the hulls. In this section the details of the final analytical thesis model will be discussed. Specific equations from the model will be provided in Appendix A. While any programming language would have been perfectly acceptable computational tool, the MathCAD program was used to perform the calculations for the analytical model due to its visually attractive mathematical interface.

Classification societies such as the American Bureau of Shipping (ABS) [3] or Det Norske Veritas (DNV) [4] often state design codes for ships strength in terms of the ship’s relevant dimensions and a sea-state coefficient dependent on ships dimensions to provide sufficient design margin for the life of a ship. The goal of the analytical thesis model is to be able to state similar design loadings based on the relevant parameters of a trimaran ship. The design loadings obtained for the load cases described sections 3.1.2, 3.1.3, and 3.1.4 are shown below in Table 3 while the relevant design parameters of the trimaran ship are shown in Table 4.

Table 3 –Structural Loading from sections 3.1.2, 3.1.3, and 3.1.4

FB_{lg}	the vertical force on cross-structure in longitudinal waves (troughing and cresting)
MB_{lg}	the moment on cross-structure in longitudinal waves (longitudinal twisting)
FB_{tr}	the vertical force in transverse waves (transverse hogging/sagging)

Table 4 – Relevant Trimaran Parameters Affecting Design Loading

B_m	the main hull’s beam
L_m	the main hull’s length
T_m	the main hull’s draft
F_m	the main hull’s freeboard (also side hull freeboard)
B_s	the side hull’s beam
L_s	the side hull’s length
T_s	the side hull’s draft
X_s	the longitudinal position of the side hull wrt main hull amidships
Y_s	the transverse position of the side hull wrt main hull centerline

4.1.1 Analytical Model Parts

The analytical model used for this work consists of two major components. These are the calculation of the ships motions and forces and the calculation of the representative sea states. Each part is described below with its corresponding equation provided in Appendix A.

4.1.1.1 Entry of Statistical Sea State

A joint frequency table in both wave period and significant wave height for the northern North Atlantic Ocean was obtained from [14]. This table was converted to a joint probability table whose results are shown below in Table 5 and Table 6. This joint probability table of wave height and period was used for a statistical representation of the most severe sea state in which the trimaran hull form would be subjected. The data represented in Table 5 and Table 6 is often approximated with well known distributions such as the Breitschneider or other spectra. However, these spectra often described in only a few parameters and do not always fully capture the true nature of the joint probability of the sea state in the wave height and wavelength parameters. Therefore, the observed tabular data was utilized.

Table 5 – Joint Probability Mass Table of Significant Wave Height and Period

		Spectral Peak Period (s)								
		3	4	5	6	7	8	9	10	11
Significant Wave Height (m)	0.5	0.0006	0.004	0.0106	0.0157	0.0163	0.0136	0.0098	0.0064	0.0039
	1.5	9E-05	0.0021	0.0123	0.0322	0.0511	0.0581	0.0528	0.041	0.0285
	2.5	0	8E-05	0.0015	0.0083	0.0229	0.039	0.0471	0.0446	0.0353
	3.5	0	0	6E-05	0.0008	0.0048	0.0137	0.0241	0.0296	0.028
	4.5	0	0	0	4E-05	0.0006	0.0031	0.009	0.0156	0.0188
	5.5	0	0	0	0	3E-05	0.0004	0.0021	0.0057	0.0095
	6.5	0	0	0	0	0	2E-05	0.0003	0.0014	0.0035
	7.5	0	0	0	0	0	0	2E-05	0.0002	0.0009
	8.5	0	0	0	0	0	0	0	2E-05	0.0001
	9.5	0	0	0	0	0	0	0	0	2E-05
	10.5	0	0	0	0	0	0	0	0	0
	11.5	0	0	0	0	0	0	0	0	0
	12.5	0	0	0	0	0	0	0	0	0
	13.5	0	0	0	0	0	0	0	0	0
	14.5	0	0	0	0	0	0	0	0	0

Where each wave height indicated is the center of a 1 meter range of heights

Table 6 – Joint Probability Mass Table of Significant Wave Height and Period

		Spectral Peak Period (s)									
		12	13	14	15	16	17	18	19	21	22
Significant Wave Height (m)	0.5	0.0023	0.0013	0.0007	0.0004	0.0002	0.0001	7E-05	4E-05	2E-05	2E-05
	1.5	0.0182	0.011	0.0063	0.0035	0.0019	0.001	0.0006	0.0003	0.0002	0.0002
	2.5	0.0245	0.0154	0.009	0.005	0.0026	0.0013	0.0007	0.0003	0.0002	0.0001
	3.5	0.0216	0.0144	0.0085	0.0046	0.0023	0.0011	0.0005	0.0002	1E-04	7E-05
	4.5	0.017	0.0123	0.0075	0.004	0.0019	0.0008	0.0003	0.0001	5E-05	3E-05
	5.5	0.0107	0.0088	0.0057	0.0031	0.0014	0.0006	0.0002	7E-05	2E-05	1E-05
	6.5	0.0053	0.0053	0.0039	0.0022	0.001	0.0004	0.0001	4E-05	1E-05	0
	7.5	0.002	0.0026	0.0023	0.0014	0.0006	0.0002	7E-05	2E-05	0	0
	8.5	0.0005	0.001	0.0011	0.0008	0.0004	0.0001	4E-05	1E-05	0	0
	9.5	0.0001	0.0003	0.0004	0.0004	0.0002	8E-05	2E-05	1E-05	0	0
	10.5	2E-05	7E-05	0.0001	0.0002	0.0001	5E-05	1E-05	0	0	0
	11.5	0	1E-05	4E-05	6E-05	5E-05	2E-05	1E-05	0	0	0
	12.5	0	0	1E-05	2E-05	2E-05	1E-05	0	0	0	0
	13.5	0	0	0	0	1E-05	0	0	0	0	0
14.5	0	0	0	0	0	0	0	0	0	0	

Where each wave height indicated is the center of a 1 meter range of heights

4.1.1.2 Conversion of Statistical Sea State

The data represented in Table 5 and Table 6 give the joint probability of a sea state having a given significant wave height and period. However, the data given is for short term observations of a narrow-banded, fully developed sea state reported in terms of significant wave height. However, significant wave height is a one parameter descriptor of the probability distribution for a fully developed sea state. The probability of the peak values of the actual wave amplitudes for a fully developed sea state are described by a Rayleigh distribution with significant wave height as the distribution function parameter. Correspondingly, each entry of Table 5 and Table 6 actually describes the joint probability of a certain Rayleigh distribution occurring. Since the limiting design of the trimaran is concerned with an overall probability of the wave loading conditions encountered, the data in Table 5 and Table 6 was converted to represent an absolute joint probability of actual wave height verses wave period in lieu of significant wave height.

Using [15], equation (1) was derived. Equation (1) is the Rayleigh probability distribution of actual wave height in terms of significant wave height.

$$p_{\text{ray}}(h_w, t) = 4 \cdot \frac{h_w}{(H_{s_t})^2} \cdot e^{-2 \cdot \left[\frac{h_w^2}{(H_{s_t})^2} \right]}$$

(1)

Where:

p_{ray} – the Rayleigh distribution probability as functions of wave height and the index t

h_w – the actual wave height

H_s – the observed significant wave height

t – the index of the observed significant wave height in Table 5 and Table 6

Using the Rayleigh probability distribution in equation (1), for each significant observed wave height, the probability of being in each wave height range of Table 5 and Table 6 was calculated by integrating the Rayleigh distribution in one meter segments. The result of the integral was multiplied by the joint probability shown in Table 5 and Table 6 and then added to the other associated probabilities affecting that wave height region. The result is shown in below in Table 7 and Table 8.

Table 7 – Joint Probability of True Wave Height and Period (3-11 second periods)

		Spectral Peak Period (s)								
		3	4	5	6	7	8	9	10	11
Significant Wave Height (m)	0.5	0.0006	0.0053	0.0183	0.0371	0.0535	0.0609	0.0584	0.0492	0.0372
	1.5	3E-05	0.0008	0.0054	0.0163	0.0315	0.045	0.0517	0.0502	0.0424
	2.5	3E-06	8E-05	0.0007	0.003	0.0081	0.0152	0.0218	0.0252	0.0245
	3.5	3E-08	5E-06	9E-05	0.0006	0.002	0.0049	0.0085	0.0115	0.0128
	4.5	0	5E-07	1E-05	1E-04	0.0005	0.0014	0.0031	0.005	0.0063
	5.5	0	3E-08	1E-06	2E-05	0.0001	0.0004	0.0011	0.0021	0.003
	6.5	0	0	1E-07	3E-06	3E-05	0.0001	0.0004	0.0008	0.0014
	7.5	0	0	2E-08	5E-07	6E-06	3E-05	0.0001	0.0003	0.0006
	8.5	0	0	0	6E-08	1E-06	9E-06	4E-05	0.0001	0.0003
	9.5	0	0	0	1E-08	3E-07	2E-06	1E-05	5E-05	0.0001
	10.5	0	0	0	0	3E-08	5E-07	4E-06	2E-05	5E-05
	11.5	0	0	0	0	8E-09	1E-07	1E-06	6E-06	2E-05
	12.5	0	0	0	0	0	2E-08	3E-07	2E-06	7E-06
	13.5	0	0	0	0	0	5E-09	1E-07	7E-07	3E-06
	14.5	0	0	0	0	0	0	1E-08	2E-07	1E-06
	15.5	0	0	0	0	0	0	4E-09	7E-08	4E-07
	16.5	0	0	0	0	0	0	0	1E-08	1E-07
	17.5	0	0	0	0	0	0	0	4E-09	5E-08
	18.5	0	0	0	0	0	0	0	0	9E-09
	19.5	0	0	0	0	0	0	0	0	4E-09
20.5	0	0	0	0	0	0	0	0	0	
21.5	0	0	0	0	0	0	0	0	0	
22.5	0	0	0	0	0	0	0	0	0	
23.5	0	0	0	0	0	0	0	0	0	
24.5	0	0	0	0	0	0	0	0	0	
25.5	0	0	0	0	0	0	0	0	0	
26.5	0	0	0	0	0	0	0	0	0	
27.5	0	0	0	0	0	0	0	0	0	
28.5	0	0	0	0	0	0	0	0	0	
29.5	0	0	0	0	0	0	0	0	0	

Table 8 – Joint Probability of True Wave Height and Period (12-22 second periods)

		Spectral Peak Period (s)									
		12	13	14	15	16	17	18	19	21	22
Significant Wave Height (m)	0.5	0.0256	0.0163	0.0096	0.0053	0.0028	0.0014	0.0007	0.0004	0.0002	0.0002
	1.5	0.0317	0.0212	0.0128	0.007	0.0036	0.0018	0.0008	0.0004	0.0002	0.0002
	2.5	0.0203	0.0145	0.009	0.005	0.0025	0.0011	0.0005	0.0002	9E-05	7E-05
	3.5	0.0117	0.0089	0.0058	0.0032	0.0016	0.0007	0.0003	0.0001	4E-05	3E-05
	4.5	0.0063	0.0052	0.0035	0.002	0.001	0.0004	0.0001	5E-05	2E-05	1E-05
	5.5	0.0033	0.003	0.0021	0.0012	0.0006	0.0002	8E-05	3E-05	7E-06	4E-06
	6.5	0.0017	0.0016	0.0012	0.0007	0.0004	0.0001	5E-05	1E-05	3E-06	1E-06
	7.5	0.0008	0.0009	0.0007	0.0004	0.0002	8E-05	3E-05	8E-06	1E-06	5E-07
	8.5	0.0004	0.0005	0.0004	0.0003	0.0001	5E-05	1E-05	4E-06	5E-07	1E-07
	9.5	0.0002	0.0002	0.0002	0.0002	8E-05	3E-05	9E-06	2E-06	2E-07	4E-08
	10.5	9E-05	0.0001	0.0001	9E-05	5E-05	2E-05	5E-06	1E-06	8E-08	1E-08
	11.5	4E-05	6E-05	7E-05	5E-05	3E-05	1E-05	3E-06	7E-07	3E-08	3E-09
	12.5	2E-05	3E-05	3E-05	3E-05	2E-05	6E-06	2E-06	4E-07	8E-09	0
	13.5	8E-06	1E-05	2E-05	2E-05	1E-05	4E-06	1E-06	2E-07	2E-09	0
	14.5	3E-06	7E-06	1E-05	9E-06	6E-06	2E-06	6E-07	1E-07	0	0
	15.5	2E-06	3E-06	5E-06	5E-06	3E-06	1E-06	3E-07	5E-08	0	0
	16.5	6E-07	1E-06	2E-06	3E-06	2E-06	7E-07	2E-07	2E-08	0	0
	17.5	3E-07	7E-07	1E-06	1E-06	1E-06	4E-07	1E-07	1E-08	0	0
	18.5	7E-08	3E-07	6E-07	7E-07	6E-07	2E-07	5E-08	4E-09	0	0
	19.5	4E-08	1E-07	3E-07	4E-07	4E-07	1E-07	3E-08	2E-09	0	0
20.5	7E-09	4E-08	1E-07	2E-07	2E-07	6E-08	1E-08	0	0	0	
21.5	4E-09	2E-08	7E-08	1E-07	1E-07	4E-08	8E-09	0	0	0	
22.5	0	3E-09	2E-08	4E-08	5E-08	2E-08	3E-09	0	0	0	
23.5	0	2E-09	1E-08	2E-08	3E-08	9E-09	2E-09	0	0	0	
24.5	0	0	3E-09	6E-09	1E-08	3E-09	0	0	0	0	
25.5	0	0	2E-09	3E-09	8E-09	2E-09	0	0	0	0	
26.5	0	0	0	0	3E-09	0	0	0	0	0	
27.5	0	0	0	0	2E-09	0	0	0	0	0	
28.5	0	0	0	0	0	0	0	0	0	0	
29.5	0	0	0	0	0	0	0	0	0	0	

4.1.1.3 Equations of Applied Waves

To create the loading conditions discussed above in sections 3.1.2, 3.1.3, and 3.1.4 from the wave height and period data in Table 7 and Table 8, the waves were applied as described below.

First the deep-water wavelength approximation was made by equation (2) for each period in Table 7 and Table 8.

$$\lambda = \frac{g}{2 \cdot \pi} \cdot (T)^2 \tag{2}$$

Where:

λ – the wavelength of the wave

g – the gravitational constant

T – the wave period from Table 7 and Table 8

Equation (2) applied to each indicated wave period yielded the wavelengths indicated in below Table 9.

Table 9 – Deep Water Wavelengths

Period (s)	Wavelength (m)
3	14.05
4	24.97
5	39.02
6	56.19
7	76.48
8	99.89
9	126.42
10	156.08
11	188.85
12	224.75
13	263.77
14	305.91
15	351.17
16	399.56
17	451.06
18	505.69
19	563.44
21	688.30
22	755.42

Next the following wave equations for the longitudinal and transverse directions were applied with the proper phasing to apply the loading conditions described in sections 3.1.2, 3.1.3, and 3.1.4. The coordinate system used for the analytical model was those of traditional ship coordinate systems of x-longitudinal, y-transverse, and z-vertical. The coordinate system of the analytical model is shown below in Figure 11.

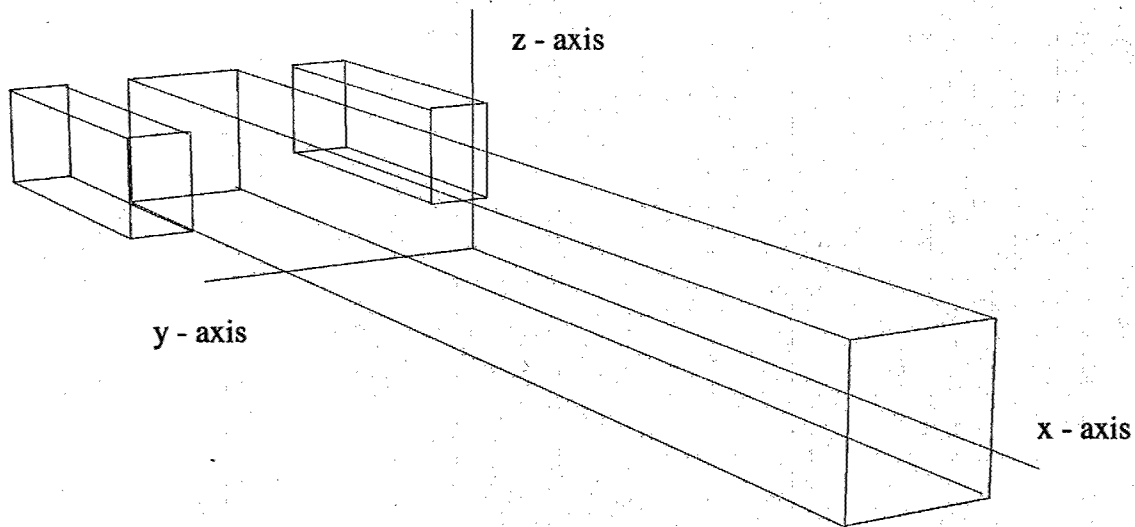

Figure 11 - Analytical Model Coordinate System

The wave equations used to create the specific loading conditions are show below in equations (3) and (4).

$$H_{\text{wave_lg}}(x, p, q, \phi, X_s) = \frac{h_{w_p}}{2} \cdot \sin \left[\frac{2 \cdot \pi}{\lambda_q} \cdot (x - X_s) - \phi \right] \quad \phi_{lg} = \begin{pmatrix} 0 \\ 90 \\ 180 \\ 270 \end{pmatrix} \cdot \text{deg} \quad \phi_{lg} = \begin{pmatrix} \text{pos_twist} \\ \text{trough} \\ \text{neg_twist} \\ \text{crest} \end{pmatrix} \quad (3)$$

$$H_{\text{wave_tr}}(y, p, q, \phi) := \frac{h_{w_p}}{2} \cdot \cos \left[\frac{2 \cdot \pi}{\lambda_q} \cdot (y) - \phi \right] \quad \phi_{tr} = \begin{pmatrix} 0 \\ 180 \end{pmatrix} \cdot \text{deg} \quad \phi_{tr} = \begin{pmatrix} \text{hog} \\ \text{sag} \end{pmatrix} \quad (4)$$

Where:

$H_{\text{wave_lg}}$ - is the longitudinal wave amplitude as functions of the shown variables

$H_{\text{wave_tr}}$ - is the transverse wave amplitude as functions of the shown variables

h_w - the actual wave height from Table 7 and Table 8

x - the longitudinal position

X_s - the longitudinal position of the side hull wrt main hull amidships

y - the transverse position

λ - the wavelength of the wave

ϕ - the phase of the wave applied for each loading condition

p - the index of the wave height Table 7 and Table 8

q - the index of the wavelength from Table 9

Equations (3) and (4) define the wave amplitude in the longitudinal and transverse directions respectively. Both equations are functions of the index p which references the wave

heights in Table 7 and Table 8. The wave definition equations are also functions of the index q referencing the wavelengths in Table 9. Additionally equation (3) is defined so that the origin of the wave is longitudinally offset to coincide with the longitudinal center of the side hull, X_s . Equations (3) and (4) are also defined as a function of applied phase angle so that each phase angle can be easily applied to generate the load cases defined in sections 3.1.2, 3.1.3, and 3.1.4. Finally, sinusoidal waves were used to approximate the wave functions rather than trochoidal waves, which more truly represent water waves, since the difference between sinusoidal and trochoidal waves for the wavelengths of concern is relatively small.

4.1.1.4 Calculation of Motion due to Applied Waves

After the waves applied to the trimaran hull form were defined as in equations (3) and (4) above, the next step in finding the load forces on the trimarans cross-structure was to perform a static balance of the ship for a particular wave. For the longitudinal wave cases, the static balance required simultaneously solving for the pitch and heave of the ship. While solving simultaneously equations for heave and pitch of a ship is conceptually simple, the practice of executing this concept is somewhat cumbersome. To perform the static balance, the underwater volume and the first moment of that volume subjected to the wave must balance with the displacement and moment of the ship in the pitched and heaved condition. This process involved iteratively solving equations (5) and (6) below using a modified Newton's method. Equation (5) is the heave equation.

$$\begin{aligned} \nabla_{\text{still}} = B_m \cdot \int_{-\frac{L_m}{2}}^{\frac{L_m}{2}} [H_{\text{wave_lg}}(x, \phi) - \Delta T - (x - X_{cf}) \cdot \sin(\Theta_{\text{pitch}})] dx \dots \\ + 2 \cdot B_s \cdot \int_{X_s - \frac{L_s}{2}}^{X_s + \frac{L_s}{2}} [H_{\text{wave_lg}}(x, \phi) - \Delta T - (x - X_{cf}) \cdot \sin(\Theta_{\text{pitch}})] dx \end{aligned} \quad (5)$$

Where:

ΔT – the change in heave of the ship due to the longitudinal wave

Θ_{pitch} – the change in pitch of the ship due to the longitudinal wave

$H_{\text{wave_lg}}$ – is the longitudinal wave height as functions of position and phase from (3)*

x – the longitudinal position

ϕ – the phase of the wave applied for each loading condition

B_m – the main hull's beam

L_m – the main hull's length

B_s – the side hull's beam

L_s – the side hull's length

X_s – the longitudinal position of the side hull wrt main hull amidships

X_{cf} – the longitudinal position of the entire ship's center of floatation

∇_{still} – the original still water displacement

$\text{Trim}_{\text{still}}$ – the original still water trim (assumed to be zero)

* For simplicity the wave height here is only shown as functions of position and phase with wave height and wavelength indices omitted.

Equation (6) is the heave equation.

$$\begin{aligned} \text{Trim}_{\text{still}} = & B_m \int_{-\frac{L_m}{2}}^{\frac{L_m}{2}} [H_{\text{wave_lg}}(x, \phi) - \Delta T - (x - X_{\text{cf}}) \cdot \sin(\Theta_{\text{pitch}})] \cdot (x - X_{\text{cf}}) dx \dots \\ & + 2 \cdot B_s \int_{X_s - \frac{L_s}{2}}^{X_s + \frac{L_s}{2}} [H_{\text{wave_lg}}(x, \phi) - \Delta T - (x - X_{\text{cf}}) \cdot \sin(\Theta_{\text{pitch}})] \cdot (x - X_{\text{cf}}) dx \end{aligned} \quad (6)$$

Where:

The definitions of terms from equation (5) apply.

As with the longitudinal case above, the heave of the trimaran due to transverse waves was calculated in a similar manner. However, since this work does not deal with the affects of roll on the ship and takes as a worst case the "transverse hogging and sagging" described in section 3.1.4, only one integral equation was needed to solve for the ship's heave in transverse waves.

$$\nabla_{\text{still}} = L_m \int_{-\frac{B_m}{2}}^{\frac{B_m}{2}} (H_{\text{wave_tr}}(y, \phi) - \Delta T) dy + 2 \cdot L_s \int_{Y_s - \frac{B_s}{2}}^{Y_s + \frac{B_s}{2}} (H_{\text{wave_tr}}(y, \phi) - \Delta T) dy \quad (7)$$

Where:

ΔT – the change in heave of the ship due to the transverse wave

$H_{\text{wave_tr}}$ – is the transverse wave height as functions of position and phase from (4)*

y – the transverse position

ϕ – the phase of the wave applied for each loading condition

B_m – the main hull's beam

L_m – the main hull's length

B_s – the side hull's beam

L_s – the side hull's length

Y_s – the transverse position of the side hull wrt main hull centerline

∇_{still} – the original still water displacement

* For simplicity the wave height here is only shown as functions of position and phase with wave height and wavelength indices omitted.

While equations (5), (6), and (7) display the conditions for a static balance on waves, the motion parameters of heave and pitch (ΔT and Θ_{pitch}) were solved for in terms of a change from the initial still water conditions that were assumed to be zero. The motion parameters of heave and pitch in the analytical model were left as functions of several variables that defined the general characteristics of the trimarans dimensions, so that the motion of several different variations of trimarans could be computed.

4.1.1.5 Calculation of Forces due to Motion in Waves

Once the motions of the trimaran due to the static balance were found as explained section 4.1.1.4, the forces due to those motions were calculated. The motion parameters of the ship in waves in section 4.1.1.4 were determined in reference to the still water condition. Consequently, the force calculation was performed as a change from the still water waterline position of the trimaran's side hulls. For example, if the side hull is more immersed than the still water position as in the "transverse sagging" case shown in Figure 12, then the buoyancy of the water provides an upward force on the cross-structure.

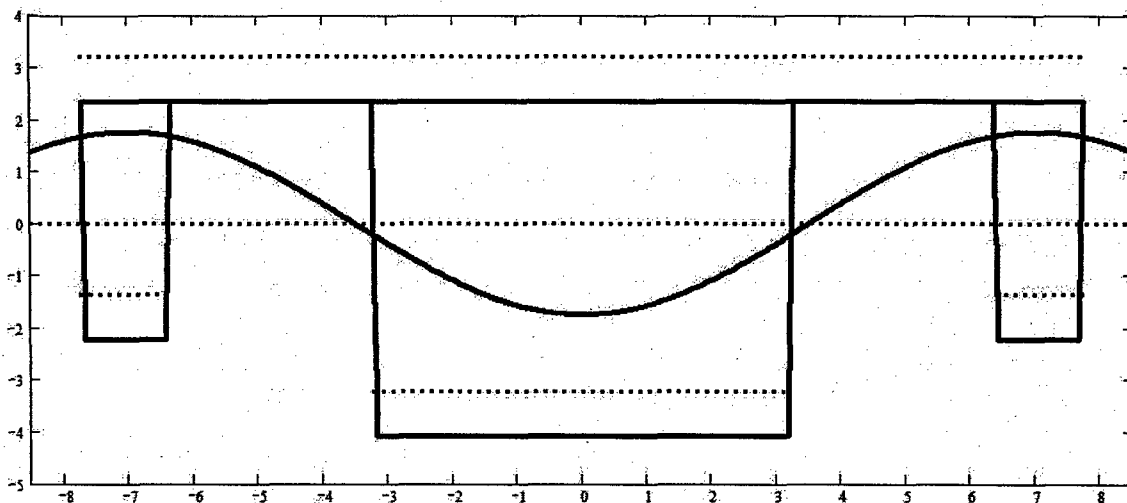

Figure 12 – Transverse Sagging Applying Upward Buoyant Force on Cross Structure

The force calculations for transverse hogging and longitudinal cresting or troughing are similar. In these cases the particular wave height and phase that the trimaran encounters either provides more or less buoyancy to the side hulls and consequently cantilevered type vertical forces are applied to the cross structure.

The twisting force applied to the cross structure of the trimaran was calculated in a similar manner as the vertical forces. The ship was statically balanced on the wave at phases of maximum twisting forces on the cross structure, and then the twisting moment due to the wave was calculated as a change from the still water condition. A case of this twisting situation is shown in Figure 13 which causes a positive twisting moment to be applied to the cross structure.

The position of the calculation of the twisting moment coincided with the longitudinal center of the side hull. The vertical position of the twisting moment was assumed to be at the original vertical position of side hull draft, which is an approximate position due the ships heaving and pitching motions.

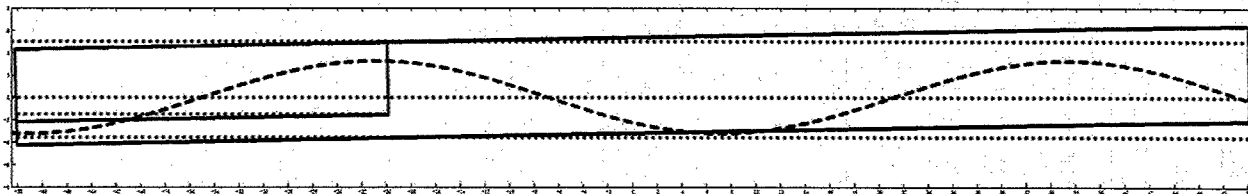

Figure 13 – Positive Phase Twisting with Side Hulls Aft

The analytical model calculated the vertical forces and twisting forces applied to the side hull due to the motion in waves. The model was generalized such that these forces were calculated as functions of many variables so that the model could be used to repetitively calculate forces for different wave states and trimaran configurations. These parameters included those of wave height, wavelength, and wave phase from the wave equations of (3) and (4). The pertinent parameters of the trimaran such as length, beam, draft, hull spacing and freeboard were also included in the force calculations.

The dependent forces variables and there independent variables are shown below in equations (8), (9), and (10) with position of application shown in Figure 14 their full definition of calculation shown in Appendix A.

$$FB_{lg}(p, q, \phi, X_s, X_{cf}, T_s, L_s, B_s, F_m, T_m, B_m, L_m) \quad (8)$$

$$MB_{lg}(p, q, \phi, X_s, X_{cf}, T_s, L_s, B_s, F_m, T_m, B_m, L_m) \quad (9)$$

$$FB_{tr}(p, q, \phi, Y_s, T_s, L_s, B_s, F_m, T_m, B_m, L_m) \quad (10)$$

Where:

FB_{lg} – the vertical force on cross-structure in longitudinal waves (troughing and cresting)

MB_{lg} – the moment on cross-structure in longitudinal waves (longitudinal twisting)

FB_{tr} – the vertical force in transverse waves (transverse hogging/sagging)

p – the index of the wave height Table 7 and Table 8

q – the index of the wavelength from Table 9

ϕ – the phase of the wave applied for each loading condition

X_{cf} – the longitudinal position of the entire ship's center of floatation

X_s – the longitudinal position of the side hull wrt main hull amidships

T_m – the main hull's draft

B_m – the main hull's beam

L_m – the main hull's length

F_m – the main hull's freeboard (also side hull freeboard)

T_s – the side hull's draft

B_s – the side hull's beam

L_s – the side hull's length

Y_s – the transverse position of the side hull wrt main hull centerline

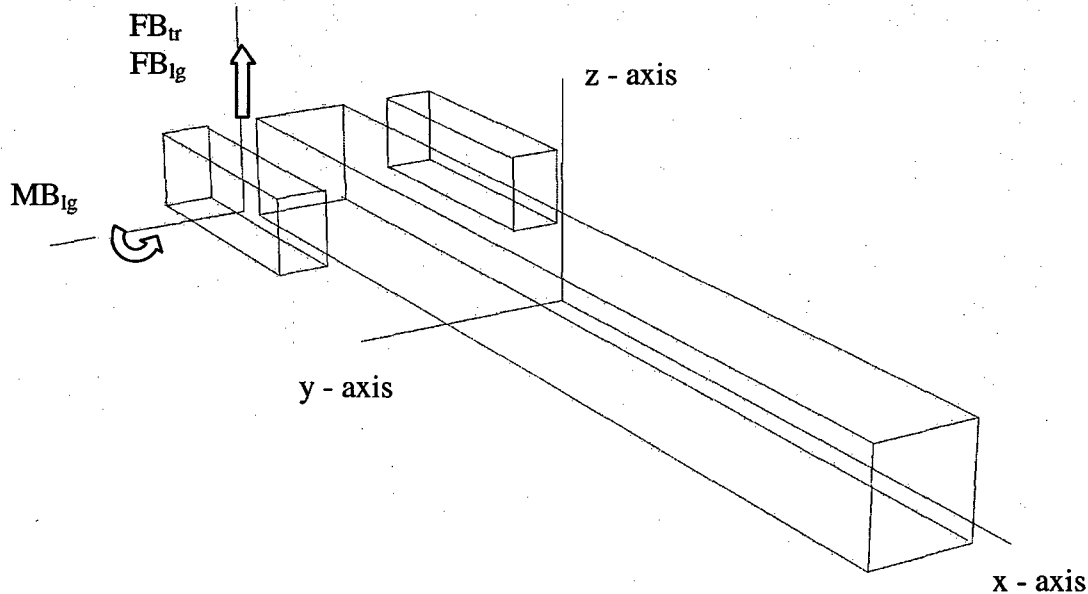

Figure 14 – Analytical Model Position of Calculated Forces

One main assumption for the calculation of forces and moments in the analytical model was that the initial still water position of the side hulls provided a neutrally buoyant displacement. This neutrally buoyant condition enforces a condition that there are no applied forces to the cross structure due to still water buoyancy conditions. While this would seem to be a reasonable design condition, it would not be a necessary condition and any imbalance in the still water forces would require accounted for. For the purpose of this work, however, the still water loading was assumed to be zero so that the nature of the structural loading in waves could be determined by equations (8), (9), and (10).

Another simplification in the analytical model was that wet deck slamming of waves with large wave heights into the trimaran cross-deck structure was not taken into account. While this assumption will eventually need to be restored to fully calculate the structural effects of sea state on trimarans, the effects were not found to be extremely relevant given the scope of this investigation. For example, for a 100m long trimaran of representative dimensions from Table 1, to obtain impact of waves with the trimarans cross deck structure would require significant wave heights on the order of 6 meters. This wave height corresponds to sea states of 6 or 7 [14]. Not only are these sea states very high for a ship of 100 meters, but also these sea states are relatively unlikely probabilistically as can be seen in Table 5 and Table 6. Therefore, discounting the cross-deck slamming for this analysis can be justified for this work.

4.1.1.6 Calculation of Design Forces due to a Full Sea Spectrum

Once the functions used to calculate the forces on the cross deck structure were defined in equations (8), (9), and (10), it was then possible to define a design load that the cross deck structure of a trimaran must withstand. Design loads are often stated in terms of safety factors or design margins. But at the root of a statistical design process design loads can also be stated in terms of the reliability index, which is what was used in this work. The reliability index used for this investigation was 5, which is suggested for naval war ships in [16]. In the strictest sense, the reliability index must take into account the probability distributions of both the load and the strength factors of a design. However, for the purpose of this work only the probability distribution of the sea-state and thus wave loading was used in the calculation of the reliability index. Omitting the probabilistic nature of the strength curves equates to knowing the failure strength deterministically, which is a reasonable simplification when considering steel

manufacturing quality assurance techniques. Once the design loading for a trimaran of general dimensions is determined, the partial safety factors for each possible failure mode could then be calculated if desired [16].

In addition to the reliability index, the other information need to determine the design loading for each load case of defined in sections 3.1.2, 3.1.3, and 3.1.4, was the susceptible wavelength for trimaran of particular dimensions. For example, the United States Naval design standard [17] and [18] for primary hull bending of a monohull ship has been to design for a trochoidal wave as shown in (11).

$$h_w = 1.1 \sqrt{L_m} \quad \lambda = L_m \quad (11)$$

While equation (11) approximates the loadings of a fully statistical sea-state relatively well for traditional naval ships, the formulation does not work well for a trimaran due to the varying lengths and spacing of the trimaran hulls. Therefore, the susceptible wave length for each load case described in sections 3.1.2, 3.1.3, and 3.1.4 was determined by finding the wavelength in which the maximum forces were produced from equations (8), (9), and (10) when considering the fully statistical sea state as described in Table 7 and Table 8.

However, computing the forces produced for each entry in Table 7 and Table 8 requires statically rebalancing the trimaran for each wavelength and wave height in Table 7 and Table 8. The amount of computational effort to solve the static motion balance for all the entries in the statistical sea state is extremely large and essentially unnecessary since the low wave height waves will not produce high forces regardless of wave length. Therefore, to determine the wavelengths to which a trimaran of particular dimensions were susceptible, the forces encountered for each entry of a statistical sea state described in Table 7 and Table 8 were effectively searched for the highest forces. To alleviate the need for calculating every force produced at every possible sea state described in Table 7 and Table 8, two simplifications were made. First, only wavelengths that would have the ability to produce a maximum force were considered. For example, the structural response of a trimaran with a main hull length of 100 meters is minimal on a wave of with a wavelength of 755 meters from Table 9. This situation can be seen in Figure 15. In the case where the wavelength encountered is much longer than the

length of the ship the ship gently rides the wave without experiencing large structural loadings. This concept is also the basis for the Naval design rules in (11).

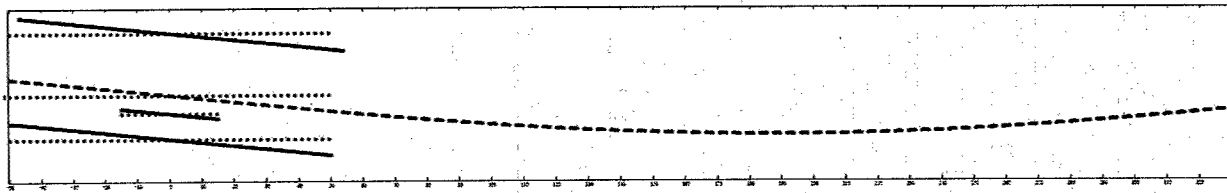

Figure 15 – Profile View of 100m Trimaran Balanced on a Wave of Long Wavelength

The second method utilized to reduce the computational effort of finding the susceptible wavelengths of a trimaran was to only calculate the forces produced from the maximum wave height for each respective wavelength which had a non-zero statistical probability in Table 7 and Table 8. Once the forces for the maximum wave height for each wavelength were calculated, the forces were compared and the susceptible wavelength was determined from the corresponding maximum force. For example, for the wave periods of 4 and 5 seconds the forces produced for 5.5 and 7.5 meter wave heights were calculated and compared.

Using these methods, the forces for each loading case in sections 3.1.2, 3.1.3, and 3.1.4 were calculated when subjected to applicable portions of the statistical sea state in Table 7 and Table 8. From those calculations, the susceptible wavelength index was set to the wavelength for the corresponding maximum force obtained. Once the susceptible wavelength for a given loading condition was determined, the design loading for that mode of loading could be calculated.

To determine the design loading for the susceptible wavelength, the joint probabilities in Table 7 and Table 8 were converted to a marginal probability distribution at the susceptible wavelength. Next, the force developed at each wave height in Table 7 and Table 8 at the susceptible wavelength was found. Finally, using the marginal probability and the developed forces at one meter wave height increments, the mean and standard deviation of the force distribution at the susceptible wavelength was determined. From there the design loading for each load case was determined using the reliability index of 5 so that the design loading would be 5 standard deviations from the mean loading.

This methodology of determining design loading was based on the joint probability mass function of Table 7 and Table 8. While this method certainly lends insight into the structural

loading of trimarans due to wave motions, the tabular nature of the probability distributions in Table 7 and Table 8 leaves the evaluation of the forces experienced in waves somewhat granular. A more in depth investigation of this subject could be performed using a continuous functions to describe the sea-state probability distribution as in [13], but for the purposes of this work's investigation into the basic structural loading attributes of a trimaran hull for would be unnecessary.

4.1.1.7 Calculation of Design Forces for Varying Sizes of Trimarans

Once the design forces as functions of the relevant parameters of the trimaran could be determined using the methods in section 4.1.1.6, the final component of the analytical thesis model computed the design forces for 468 different variations of trimaran sizes and placement configurations to investigate the possible design space of trimaran hull forms. The inputs that were allowed to vary were main hull length, side hull length, side hull x-location, side hull y-location these are shown in Table 10.

Table 10 – Parameters varied for Trimaran Design Space

L_m (main hull's length)	60 - 300 meters in 20meter increments
L_s (side hull's length)	0.25 - 0.50 in increments of 0.05 of L_m (main hull's length)
X_s (longitudinal position of the side hull with respect to main hull amidships)	Five equally spaced position from aligned amidships to where aft perpendiculars of side and main hulls are aligned
Y_s (transverse position of the side hull with respect to main hull centerline)	1 - 1.5 of B_m (main hull's beam) in increments of 0.1

The other relevant parameters needed for the computations, for example side hull beam, were calculated from fixed relations from Table 2 and reference [1] these are shown below in Table 11.

Table 11 – Parameters Held in Fixed Relations for Trimaran Design Space

B_m (main hull's beam)	Maintain $L_m / B_m = 14$
T_m (main hull's draft)	Maintain $B_m / T_m = 2$
D_m (main hull's depth) Required to find (F_m , main hull's freeboard)	Maintain $D_m / T_m = 2.4$
V_s (side hull volume)	Maintain at 4% V_m (main hull volume)
B_s (side hull's beam)	Maintain $B_s = T_s$ (side hull's draft)
T_s (side hull's draft)	Fixed by above constraints on V_s L_s B_s

The results of the required design force calculations for the design space are shown in Appendix B with an explanation of the analysis of the data provided in section 5.1.

4.2 Finite Element/ MAESTRO Analysis

Once the results from the analytical thesis model were obtained, a more refined model of a trimaran was made. The program used to create a more realistic model of a trimaran was the ship structural design program called Method for Analysis Evaluation and Structural Optimization (MAESTRO). The MAESTRO program, distributed by Proteus Engineering, was developed to analyze ship structures in a quasi-finite element analysis, with large stiffened panels as the elements between the finite element nodes. The utility of using a ship structural program such as MAESTRO is that it allows the ability to automatically balance a floating ship's structure in water utilizing linear wave theory. Naturally, the ability to include all the relevant hydrodynamic forces in the structural design of a ship is critical to accurate and safe ship design. In this case, MAESTRO only performs a static balance of a ship in waves, rather than a full dynamic analysis of the structure interacting with the ocean. However, allowing a static analysis that includes corrections for linear wave theory makes MAESTRO's results that much closer to reality.

4.2.1 Refined Finite Element MAESTRO Model

The complexity of building the MAESTRO model to the individual scantling of each component of the trimaran would be prohibitive for an initial investigation of the previous design space performed in 4.1.1.7. Therefore, one MAESTRO model was made to test the validity of the prediction of the analytical model presented in section 4.1. The particulars of the model in MAESTRO were obtained from [19] and are shown below in Table 12.

Table 12 – Particular Dimensions of Real Ship Model Used

parameter	meters
L_m	106
B_m	9
T_m	5.2
D_m	11.9
L_s	35
B_s	1.8
T_s	1
X_s	-35.5 from amidships
Y_s	9

Using the relations in the analytical thesis model developed in section 4.1, the design loadings for longitudinal cresting/troughing, longitudinal twisting, and transverse hogging/sagging from sections 3.1.2, 3.1.3, and 3.1.4, were found. The results of these design values are shown below in Table 13.

Table 13 – Analytical Model Predictions for Comparison to MAESTRO

Load Case	Force / Moment	Susceptible Wavelength (m)
Longitudinal Troughing	$-5.49 \times 10^5 \text{ N}$	76.5
Longitudinal Cresting	$5.72 \times 10^5 \text{ N}$	76.5
Positive Longitudinal Twist	$9.12 \times 10^6 \text{ Nm}$	56.2
Negative Longitudinal Twist	$-1.16 \times 10^7 \text{ Nm}$	99.9
Transverse Sagging	$1.09 \times 10^6 \text{ N}$	25.0
Transverse Hogging	$-5.22 \times 10^5 \text{ N}$	14.0

A representative MAESTRO model from [19] using the parameters of Table 12 was simulated using the MAESTRO program. This model is shown below in Figure 16 through Figure 18. The input file of the MAESTRO model is approximately 60 pages of text files, and hence has not been included as an appendix to this work.

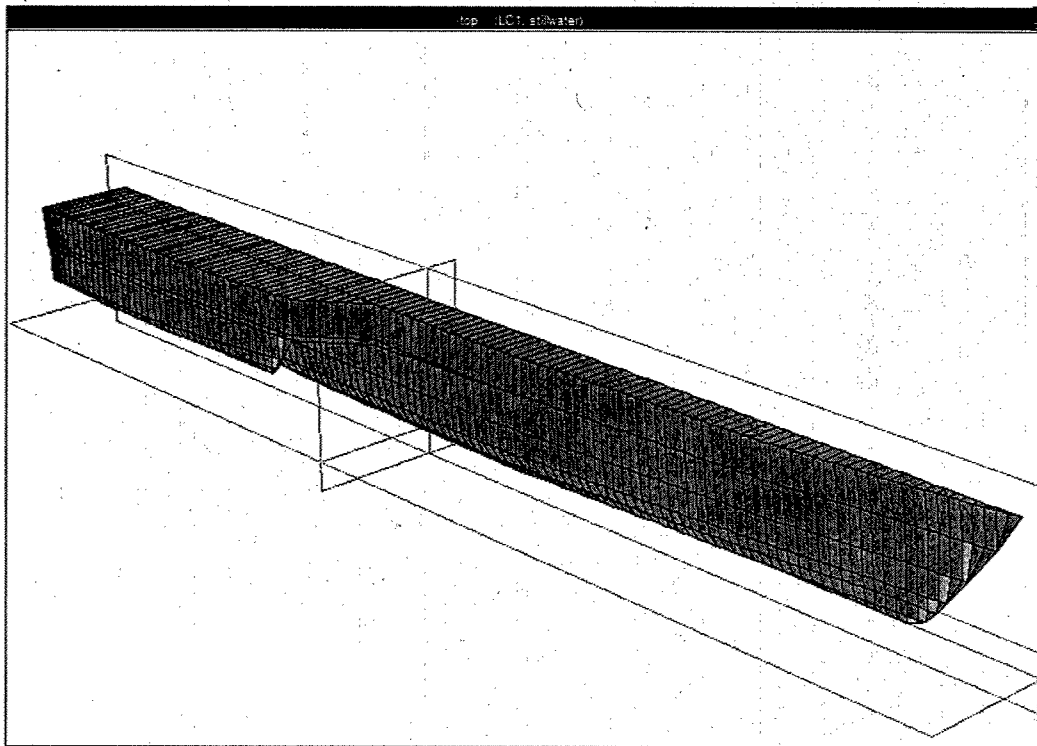

Figure 16 – Starboard Bow Perspective of a MAESTRO Trimaran Half Model

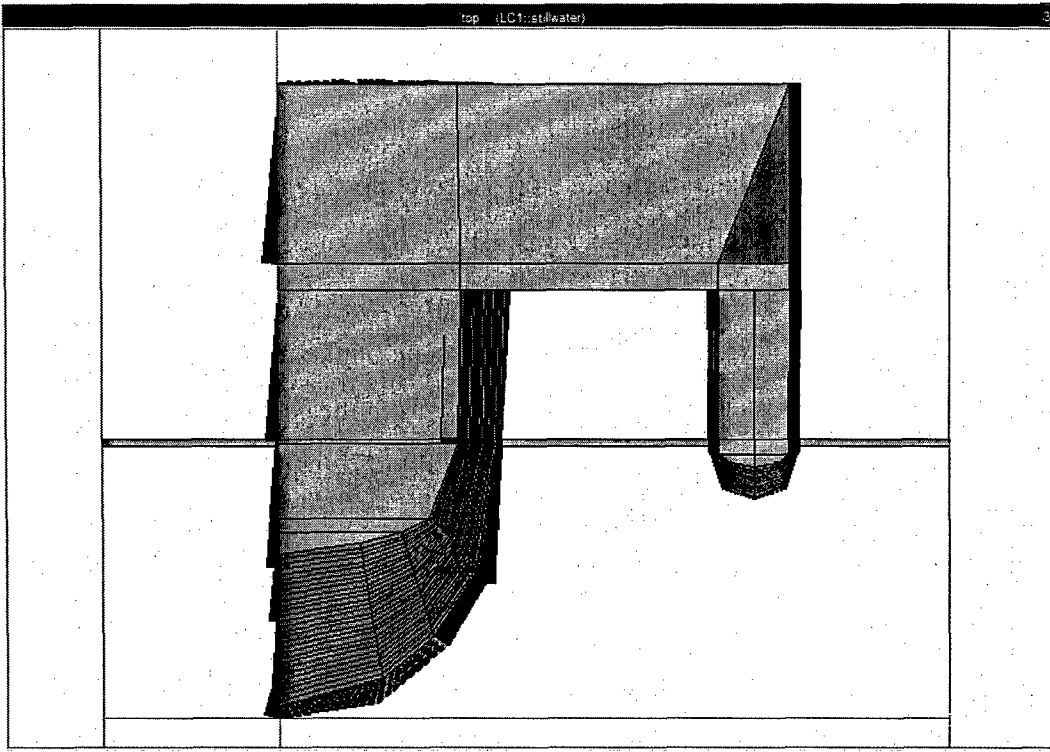

Figure 17 – Aft Body Plan View of a MAESTRO Trimaran Half Model with Water Line

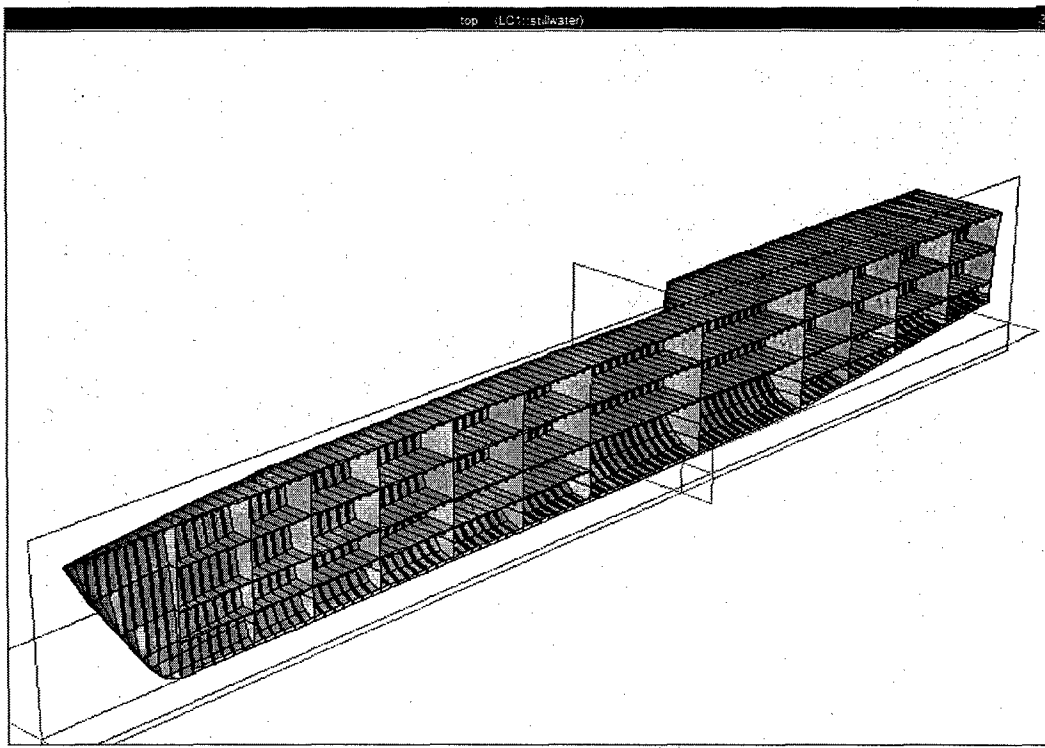

Figure 18 – Port Bow Perspective of a MAESTRO Trimaran Half Model

4.2.2 Statistically Significant Waves for the MAESTRO Model

As mentioned previously in section 4.1.1.6 a reliability index of 5 was used in the calculation of the design forces that a trimaran's cross structure should be able to withstand under the various loading cases defined in sections 3.1.2, 3.1.3, and 3.1.4. The use of the reliability index implies that the ship's Response Amplitude Operator (RAO) to a given sea state is known so that the forces produced by a particular sea state on the trimaran structure in particular failure modes can be calculated. Alternatively, as in the case of the analytical model in section 4.1, the forces produced could be calculated directly to response of the fully statistical sea state input without specifically knowing the RAO. However, to adequately compare the design forces predicted by the analytical model to the finite element model in MAESTRO the RAO of the MAESTRO model would have to be known or approximated. However, calculating the RAO of a new ship such as the trimaran would require a fully dynamic analysis including hydrodynamic effects, which is the difficult and largely unknown task in the first place.

This unknown RAO for the trimaran leads to the question of which wave height corresponds to producing a force that has a reliability index of 5, giving a design force of 5 standard deviations over the mean force for the fully statistical sea states described in Table 7 and Table 8. When dealing with ship response to waves, often motion RAO's are unity in the low frequency limit [15], which is exactly the static balance performed by MAESTRO. Therefore, the assumption was made that using wave heights that were five standard deviations above the mean wave height for each wave length would produce a force response in the various load cases described in sections 3.1.2, 3.1.3, and 3.1.4 that are five standard deviations over the mean.

Using the data from Table 7 and Table 8, the wave height to produce a response equivalent to the reliability index of 5 was calculated using the algorithm shown in Appendix C with the results shown below in Table 14.

Table 14 – Equivalent Wave Height for Reliability Index of 5

Wave Period (sec)	Wave Length (m)	Mean + 5SD Wave Height (m)
3	14.05	1.81
4	24.97	2.71
5	39.02	3.48
6	56.19	4.24
7	76.48	5.07
8	99.89	5.98
9	126.42	7.00
10	156.08	8.10
11	188.85	9.26
12	224.75	10.40
13	263.77	11.45
14	305.91	12.32
15	351.17	12.85
16	399.56	12.97
17	451.06	12.30
18	505.69	11.10
19	563.44	9.91
21	688.30	8.13
22	755.42	7.08

The values in Table 14 are also plotted in Figure 19. The shape and magnitude in Figure 19 roughly correspond to the wave coefficient values in the rule based formulas for longitudinal bending in references [3] and [4]. The fact that Figure 19 is so similar to current rule based classification societies wave coefficients implies that the simplification of applying a wave with a wave height that is 5 standard deviations over the mean for a given wavelength is most likely a valid simplification and concurs with current classification society practices.

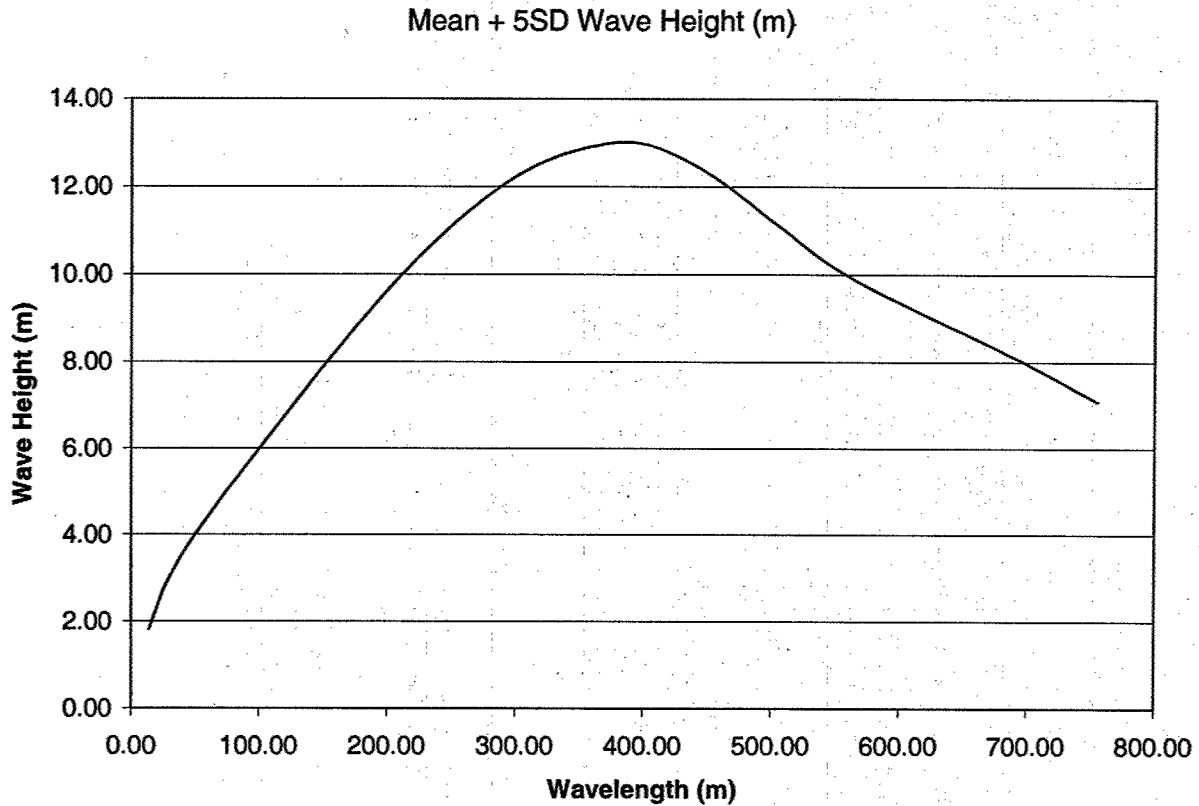

Figure 19 – Reliability Index Wave Heights of 5 verses Wavelength

Using the wave height and length data from Table 14 in conjunction with the load cases defined above in sections 3.1.2, 3.1.3, and 3.1.4, the MAESTRO program was used to compare how well the predicted values of forces from the analytical model match the wave balanced forces of the MAESTRO model.

4.2.3 MAESTRO Structural Failure Modes

The specific failure modes analyzed by MAESTRO from reference [20] are shown below in Table 15 through Table 17. These failure modes are specific to frame stiffened structures such as ships. The theoretical background behind these failure modes is detailed in [13].

Table 15 – Panel Failure Modes

PCSF	Panel Collapse, Stiffener Failure
PCCB	Panel Collapse, Combined Buckling
PCMY	Panel Collapse, Membrane Yield
PCSB	Panel Collapse, Stiffener Flexural/Torsional Buckling
PYTF	Panel Yield, Tension in Flange
PYTP	Panel Yield, Tension in Plate
PYCF	Panel Yield, Compression in Flange
PYCP	Panel Yield, Compression in Plate
PSPB (2 modes)	Panel Serviceability, Plate Bending
PFLB	Panel Failure Local Buckling

Table 16 – Frame Failure Modes

FCPH (3 modes)	Frame Collapse, Plastic Hinge
FYCF (3 modes)	Frame Yield, Compression in Flange
FYTF (3 modes)	Frame Yield, Tension in Flange
FYCP (3 modes)	Frame Yield, Compression in Plate
FYTP (3 modes)	Frame Yield, Tension in Plate

Table 17 – Girder Failure Modes

GCT	Girder Collapse, Tripping
GCCF	Girder Collapse, Compression in Flange
GCCP	Girder Collapse, Compression in Plate
GYCF	Girder Yield, Compression in Flange
GYCP	Girder Yield, Compression in Plate
GYTF	Girder Yield, Tension in Flange
GYTP	Girder Yield, Tension in Plate

MAESTRO measures the structural adequacy of each limiting failure mode using an adequacy parameter $g(R)$ shown in (12).

$$g(R) = \frac{1 - \gamma \cdot R}{1 + \gamma \cdot R} \quad (12)$$

Instead of using partial safety factors (γ) of 1.25 and 1.5 for the serviceability and collapse failure modes respectively, which are consistent with ship structural design practice, partial safety factors of 1 were used. Using safety factors of one is known as MAESTRO's Forensic Mode. Using MAESTRO in its Forensic Mode allowed the analytical and MAESTRO results to be compared on an equal basis. Where R is the strength ratio defined as the fraction of loading compared to the loading limit as shown in (13).

$$R = \frac{Q}{Q_L} \tag{13}$$

For each failure mode to be satisfied in each loading condition, the adequacy parameter must be above 0 to be above the failure criteria for that given failure mode.

4.2.4 MAESTRO Model Organization

The organizational tree structure of a general MAESTRO Model is shown below in Figure 20.

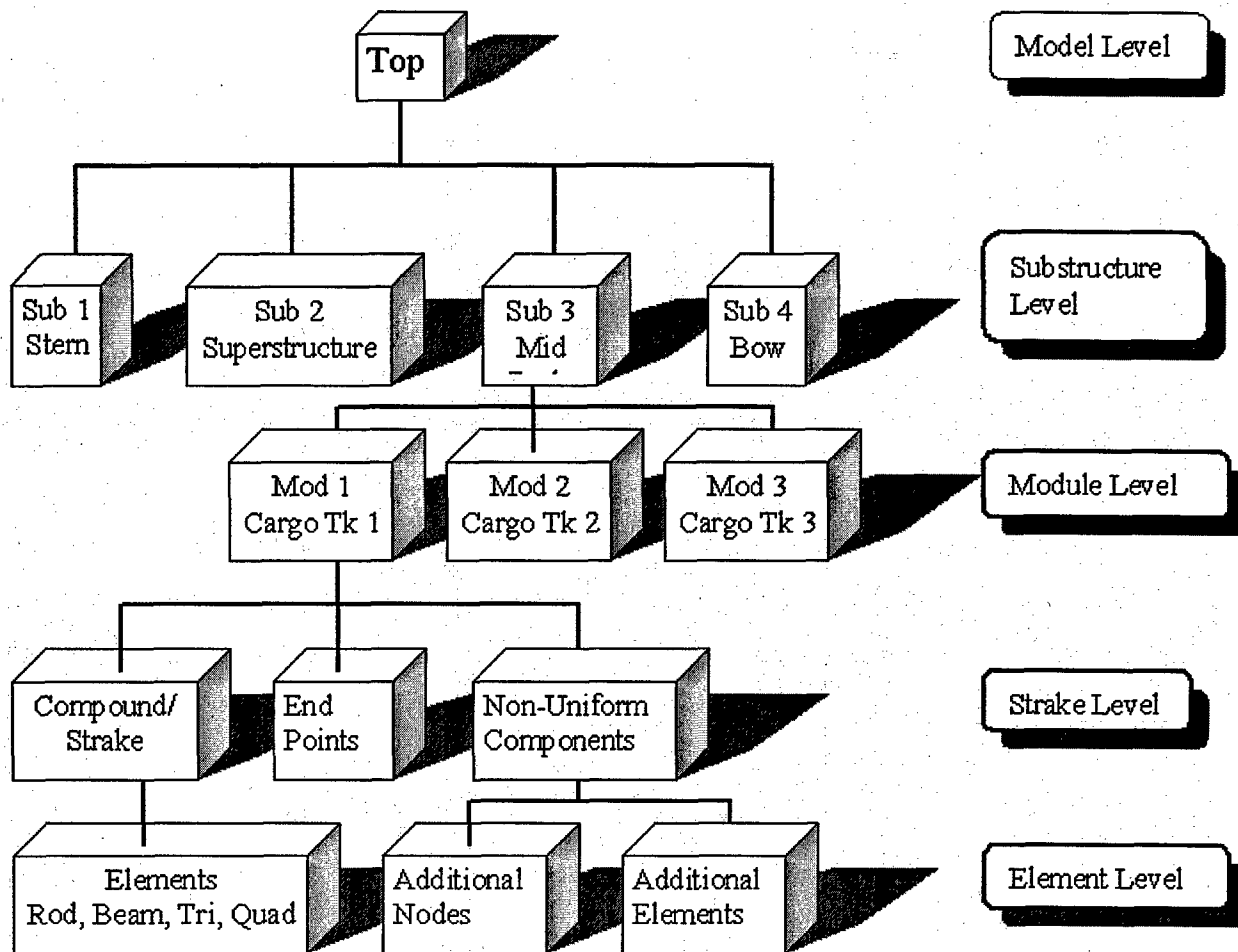

Figure 20 – Organizational Structure of a General MAESTRO Model [20]

The overall MAESTRO model is broken up into substructures, modules, strakes, and elements. The specific failure modes mentioned above in Table 15 through Table 17 are analyzed at the strake level. A strake consists of plates, stiffeners, frames, and possibly girders, in which the stiffeners, frames, and girders are often T-shapes for ship structures. This strake evaluation of the failure modes is what makes MAESTRO a macro-finite element program.

For the specific model shown in Figure 16 through Figure 18, the cross-deck structure between the main and side hulls has two substructures and five modules. While the entire

trimaran ship was modeled in eight substructures and several modules, only the substructure and module organization for the cross deck structure is shown below in Figure 21 and Figure 22.

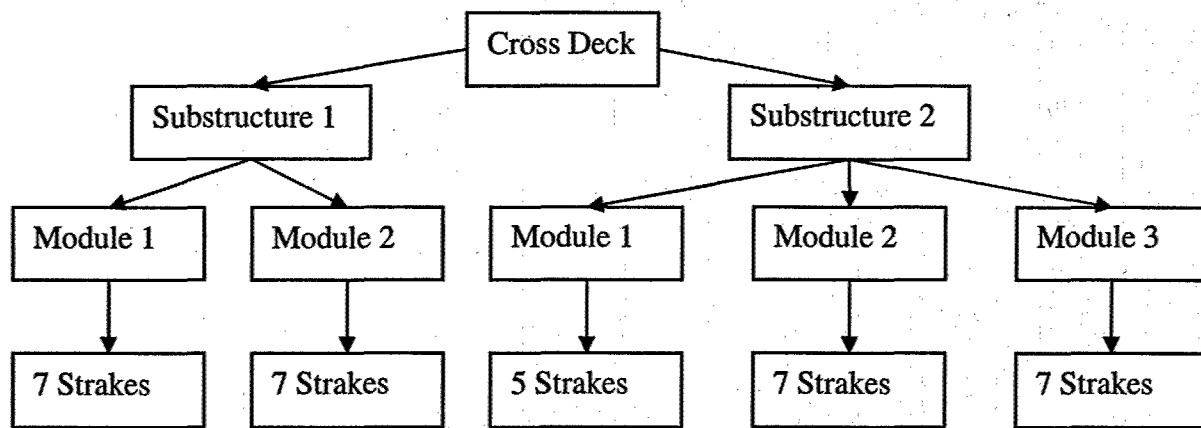

Figure 21 – Organization for the Specific MAESTRO Model Analyzed

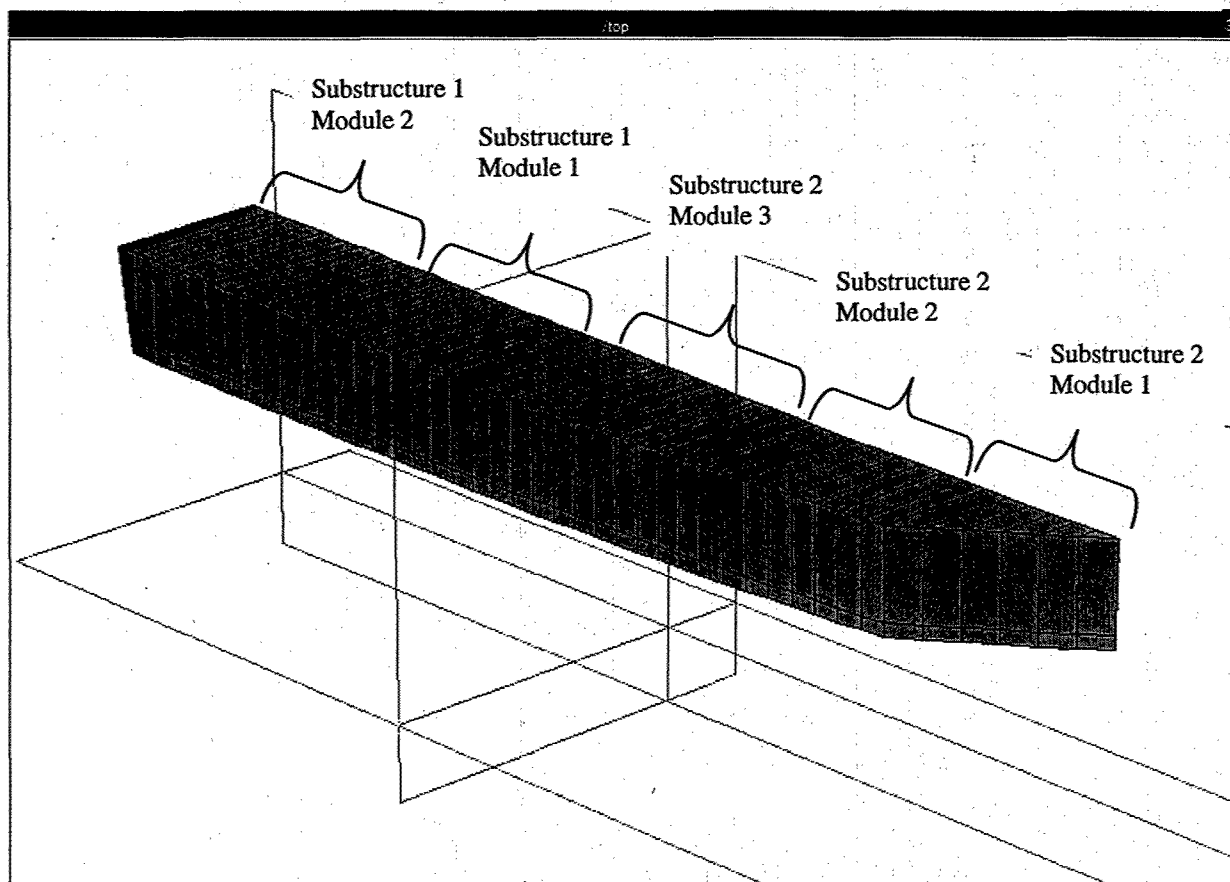

Figure 22 – MAESTRO Model Organization of Trimaran Cross-Deck Structure

4.2.5 MAESTRO Verification of Analytical Trimaran Model Predicted Forces

Once the analytical force predictions from Table 13 and the wave heights corresponding to 5 standard deviations above the mean from Table 14 at the applicable susceptible wavelengths were obtained, a basis for comparing and testing the analytical model's results to that obtained by MAESTRO in a full quasi-static linear theory wave balance was established. This comparison was accomplished by applying the analytical model's predicted forces from Table 13 as point forces in the finite element model to the stillwater MAESTRO model of the trimaran shown in Figure 16 through Figure 18, and then measuring as an output the failure modes shown in Table 15 through Table 17. Next, the MAESTRO output using the full quasi-static linear theory wave balance function provided by the MAESTRO program was analyzed. While the full output files from MAESTRO are over 1800 pages, excerpts from these output files are provided in Appendix E through Appendix J. Appendix E through Appendix J show the adequacy parameters calculated for both the analytical force predictions and the full MAESTRO quasi-static linear theory wave balance of the specific strakes from Figure 21 for each possible failure mode from Table 15 through Table 17 of the cross deck structure for the trimaran model. The discussion of the comparison of the analytical model to the MAESTRO Model results is included in section 5.2.

Chapter 5 Results

5.1 Statistical Analysis of Analytical Trimaran Model Using JMP

The tabular results of the analytical box shaped trimaran model for various main hull lengths, side hull lengths, side hull transverse spacing, and side hull longitudinal placement from section 4.1.1.7 are shown in Appendix B. To determine the relations between the various characteristics of trimarans and the forces and moments generated on a trimaran's cross structure, the statistical discovery program JMP, developed by the SAS institute, was used. JMP can be used for virtually any type of statistical analysis. However, in the case of the analytical trimaran model, JMP was used to fit the force and moment data produced to three independent variables in lengths and spacing to a fourth order polynomial including all the applicable cross terms between the independent variables.

For each load case the order of polynomial used to fit the predicted data was increased until the R-squared fit parameter and the predicted versus actual parameters were adequate to accurately predict the data in Appendix B. The entire fourth order fit equations and the curve fitting statistics are shown in Appendix D. The interaction profiles between the independent variables for each case of longitudinal cresting/troughing, longitudinal side hull twisting, and transverse sagging/hogging are shown in the following sections. The interaction plots show the interaction of the independent variables between each other and their contribution to the overall forces. For each polynomial fit obtained an accompanying equation is stated to help predict what forces an early stage structural designer can allot to the cross-structure.

5.1.1 Analytical Model Results for Longitudinal Side Hull Troughing

Figure 23 shows the side hull troughing forces as functions of the three independent variables of main hull length, side hull length as a fraction of main hull length, and side hull longitudinal placement for amidships as a fraction of main hull length.

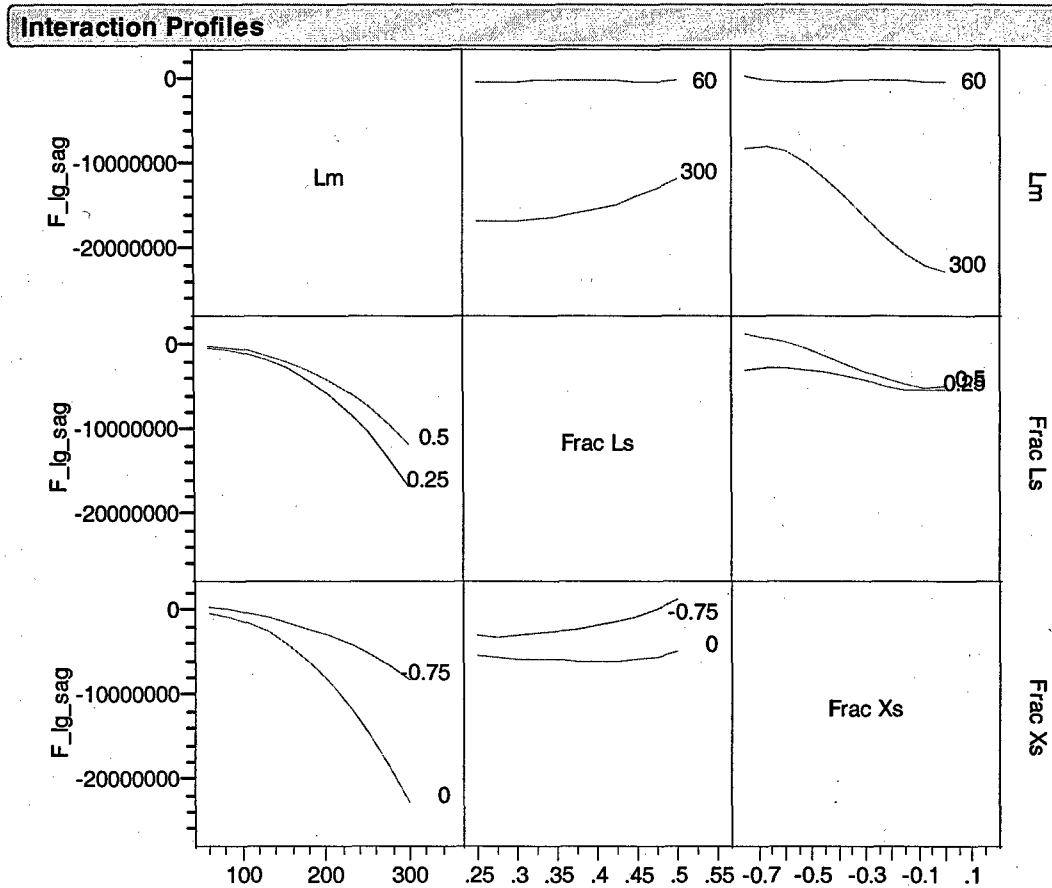

Figure 23 – Longitudinal Wave Side Hull Troughing Independent Variable Interaction

The interaction plot shows that as main hull length increases the vertical forces produced due to side hull troughing increase. This result is not surprising in view of the rising wave height versus wavelength characteristic of the statistical sea states described in Table 7 and Table 8, since as wave length of the encountered waves increases the statistically possible wave heights increase.

An interesting result from the bottom row of the interaction plot is that as the longitudinal location of the side hulls is moved aft, the trimaran's cross structure is not as susceptible to side hull troughing as when the side hull is placed in the longitudinally symmetric amidships position.

Another result from the middle row of Figure 23 is that vertical forces due to longitudinal troughing are only mildly sensitive to changes in the length of the side hull, but lessen as the length of the side hull increases. Finally, the interaction between variables can be studied as well. For example, having a smaller side hull length produces higher vertical forces when the side hulls are placed further aft than when the same side hull is placed amidships.

One final result from the side hull troughing data is the fit equation provided in (14). This equation gives the downward force as a function of three independent variables. For clarity the equation (14) is only shown to second order with the full fourth order equation included in Appendix D.

$$\begin{aligned}
 F_{\text{trough}} = & 3211000 + -61810L_m + 2225000\frac{L_s}{L_m} - 10020000\frac{X_s}{L_m} - 273.9(L_m - 180)^2 \dots \\
 & + 76210\left(\frac{L_s}{L_m} - 0.375\right) \cdot (L_m - 180) - 136600\left(\frac{X_s}{L_m} + 0.3125\right) \cdot (L_m - 180) \dots \\
 & + -18420000\left(\frac{L_s}{L_m} - 0.375\right) \cdot \left(\frac{X_s}{L_m} + 0.3125\right) - 2475000\left(\frac{X_s}{L_m} + 0.3125\right)^2 \dots \\
 & + \text{third_order_terms} + \text{fourth_order_terms}
 \end{aligned}
 \tag{14}$$

5.1.2 Analytical Model Results for Longitudinal Side Hull Cresting

The interaction profiles for the upward vertical forces produced during side hull cresting are shown below in Figure 24.

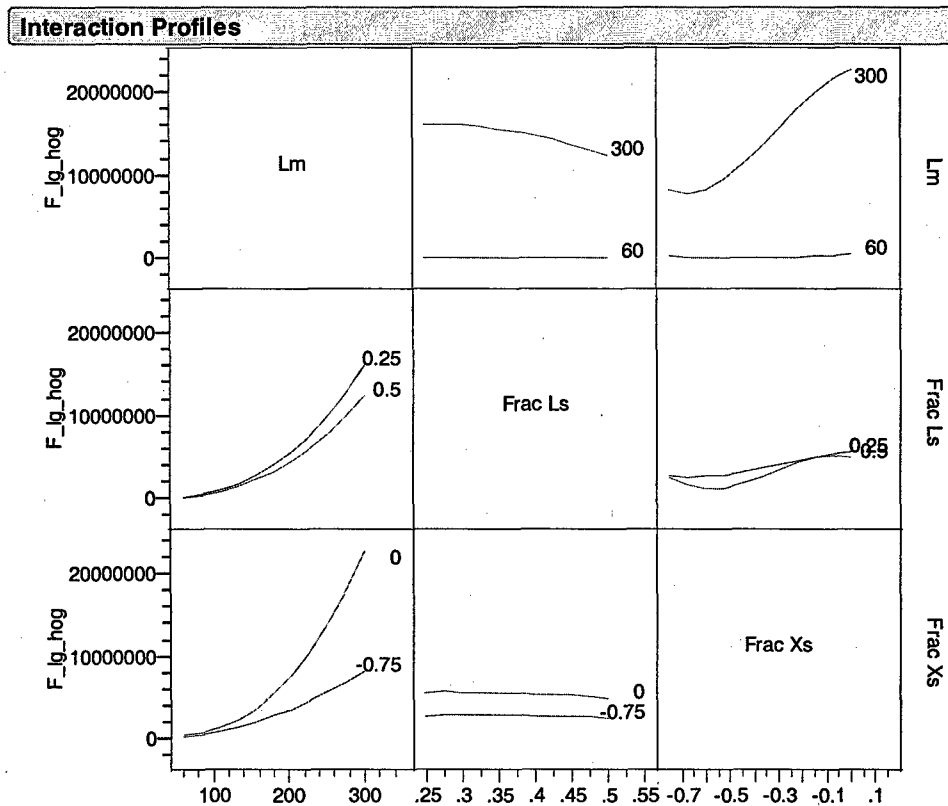

Figure 24 – Longitudinal Wave Side Hull Cresting Independent Variable Interaction

The interaction plots for side hull cresting is analogous to that of side hull troughing, and the relationships between the independent variables are essentially the same as that of side hull troughing.

The fit equation for the upward force on the side hull cross structure is partially shown in equation (15) with the full equation shown in Appendix D.

$$\begin{aligned}
 F_{\text{crest}} = & -2703000 + 58190L_m + -3016000\frac{L_s}{L_m} + 9039000\frac{X_s}{L_m} + 269.00(L_m - 180)^2 \dots \\
 & + -50870\left(\frac{L_s}{L_m} - 0.375\right) \cdot (L_m - 180) + 118600\left(\frac{X_s}{L_m} + 0.3125\right) \cdot (L_m - 180) \dots \\
 & + 19850000\left(\frac{L_s}{L_m} - 0.375\right) \cdot \left(\frac{X_s}{L_m} + 0.3125\right) \dots \\
 & + \text{third_order_terms} + \text{fourth_order_terms}
 \end{aligned}$$

(15)

5.1.3 Analytical Model Results for Longitudinal Positive Phase Twisting

The polynomial equation fit results for the positive phase twisting of the cross structure in longitudinal waves is shown below in the interaction plot of Figure 25.

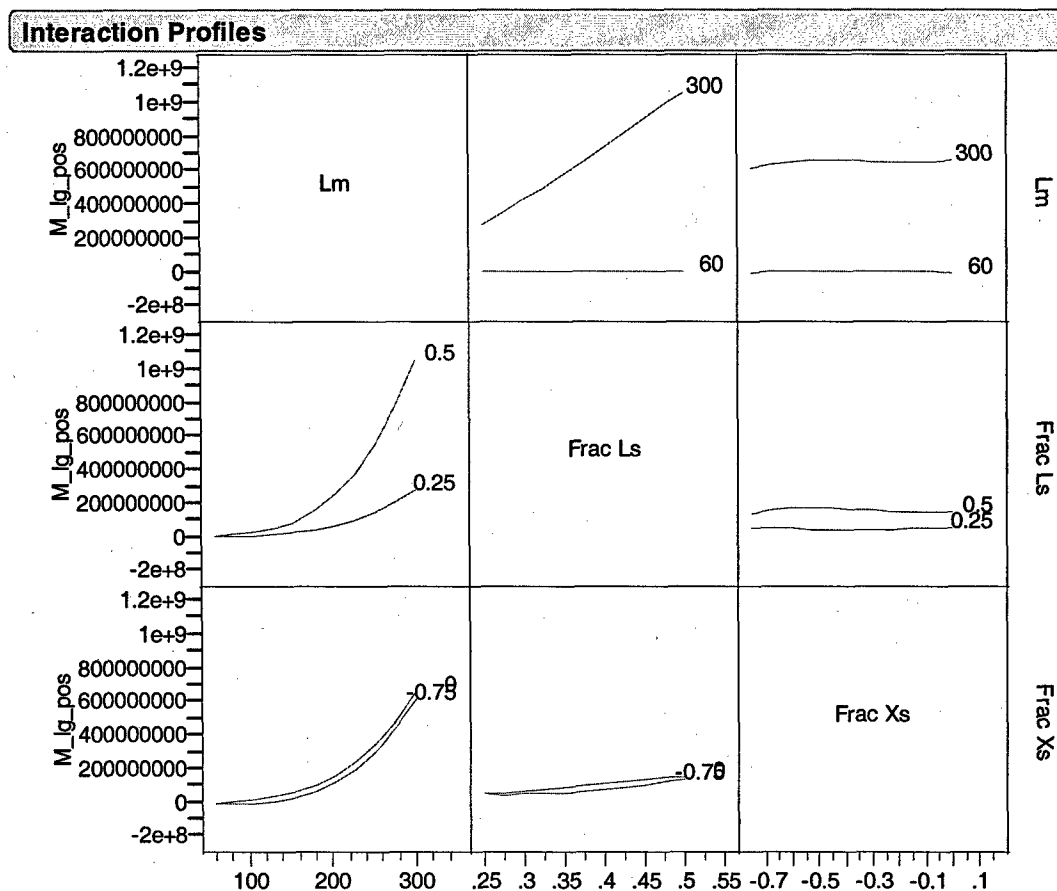

Figure 25 – Longitudinal Wave Side Hull Positive Twisting Independent Variable Interaction

Like the interaction plots for longitudinal cresting and troughing, the moments produced in positive phase twisting increases markedly as main hull length increases as is expected from the wavelengths of the susceptible sea states. From the bottom row of Figure 25 it is observed that the longitudinal placement of the side hulls has virtually no effect on the positive phase twisting moments. However, from the second row of the interaction plot, it can be seen that as the length of the side hull increases the twisting moment increases drastically. This result is not unreasonable since the length of the side hull increases the length of the moment arm for positive phase twisting.

The partial fit equation shown for positive phase twisting is shown equation (16) with the full equation shown in Appendix D.

$$\begin{aligned}
 M_{\text{pos}} = & -454800000 + 1990000L_m + 507700000\frac{L_s}{L_m} + -13040000\frac{X_s}{L_m} + 15350(L_m - 180)^2 \dots \\
 & + 10620000\left(\frac{L_s}{L_m} - 0.375\right)\cdot(L_m - 180) + -178900\left(\frac{X_s}{L_m} + 0.3125\right)\cdot(L_m - 180) \dots \\
 & + -412500000\left(\frac{L_s}{L_m} - 0.375\right)\cdot\left(\frac{X_s}{L_m} + 0.3125\right) \dots \\
 & + \text{third_order_terms} + \text{fourth_order_terms}
 \end{aligned}
 \tag{16}$$

5.1.4 Analytical Model Results for Longitudinal Negative Twisting

The polynomial equation fit results for the negative phase twisting of the cross structure in longitudinal waves is shown below in the interaction plot of Figure 26.

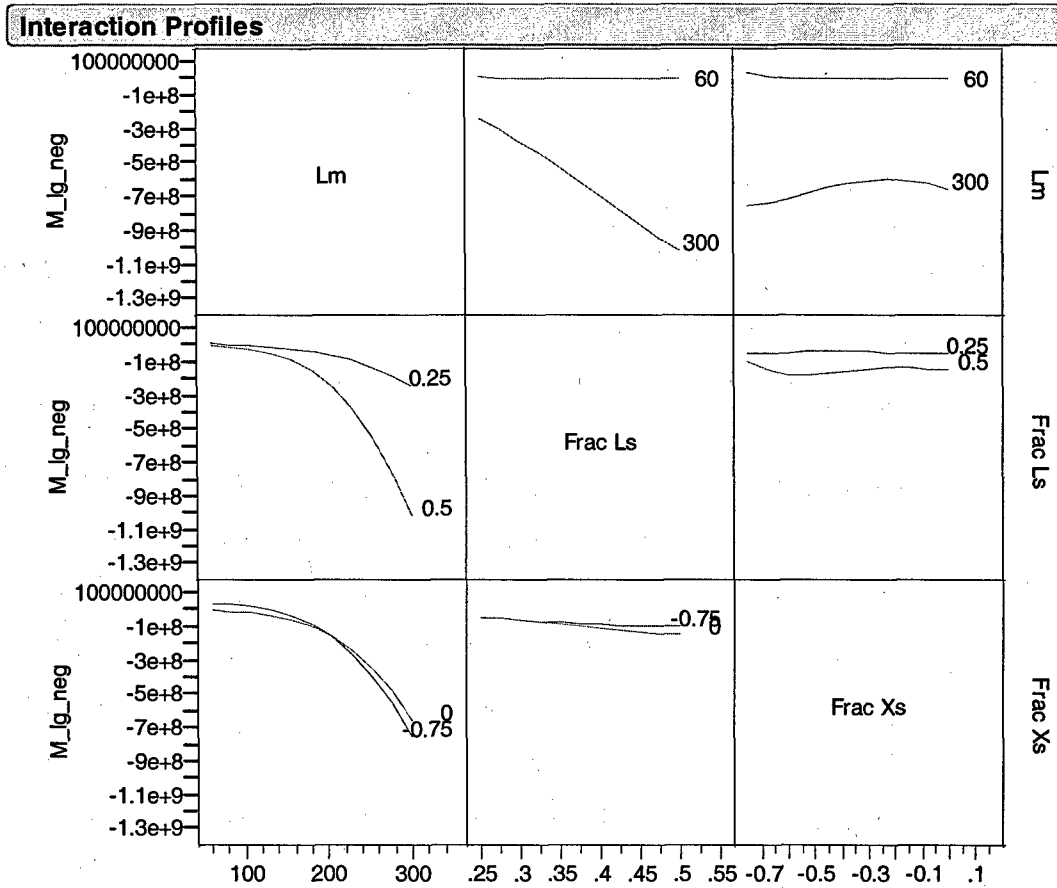

Figure 26 – Longitudinal Wave Side Hull Negative Twisting Independent Variable Interaction

The results for negative phase twisting are analogous to positive phase twisting maintaining similar trends between the independent variables.

The partial fit equation shown for positive phase twisting is shown equation (17) with the full equation shown in Appendix D.

$$\begin{aligned}
 M_{neg} = & 470200000 + -1843000L_m + -549900000\frac{L_s}{L_m} + 52640000\frac{X_s}{L_m} + -15260(L_m - 180)^2 \dots \\
 & + -10820000\left(\frac{L_s}{L_m} - 0.375\right) \cdot (L_m - 180) + 741500\left(\frac{X_s}{L_m} + 0.3125\right) \cdot (L_m - 180) \dots \\
 & + 842000000\left(\frac{L_s}{L_m} - 0.375\right) \cdot \left(\frac{X_s}{L_m} + 0.3125\right) + -430100000\left(\frac{X_s}{L_m} + 0.3125\right)^2 \dots \\
 & + \text{third_order_terms} + \text{fourth_order_terms}
 \end{aligned}$$

(17)

5.1.5 Analytical Model Results for Transverse Sagging

The results for transverse sagging are shown for the interaction plot below in Figure 27. For clarity the values in Appendix D were converted to utilize transverse dimensions stated in main and side hull beams from the fixed relations in Table 11. The interaction plots indicate that, as suspected, the upward forces on the cross structure due to a transverse sagging condition increases as the outer hull spacing increases. Another result from the interaction profile is that as the side hulls beam widens then forces on the cross structure lessens. Finally, as experienced in the previous loading cases as the size of the overall ship increases the forces experienced increase due to the statistical nature of the sea states.

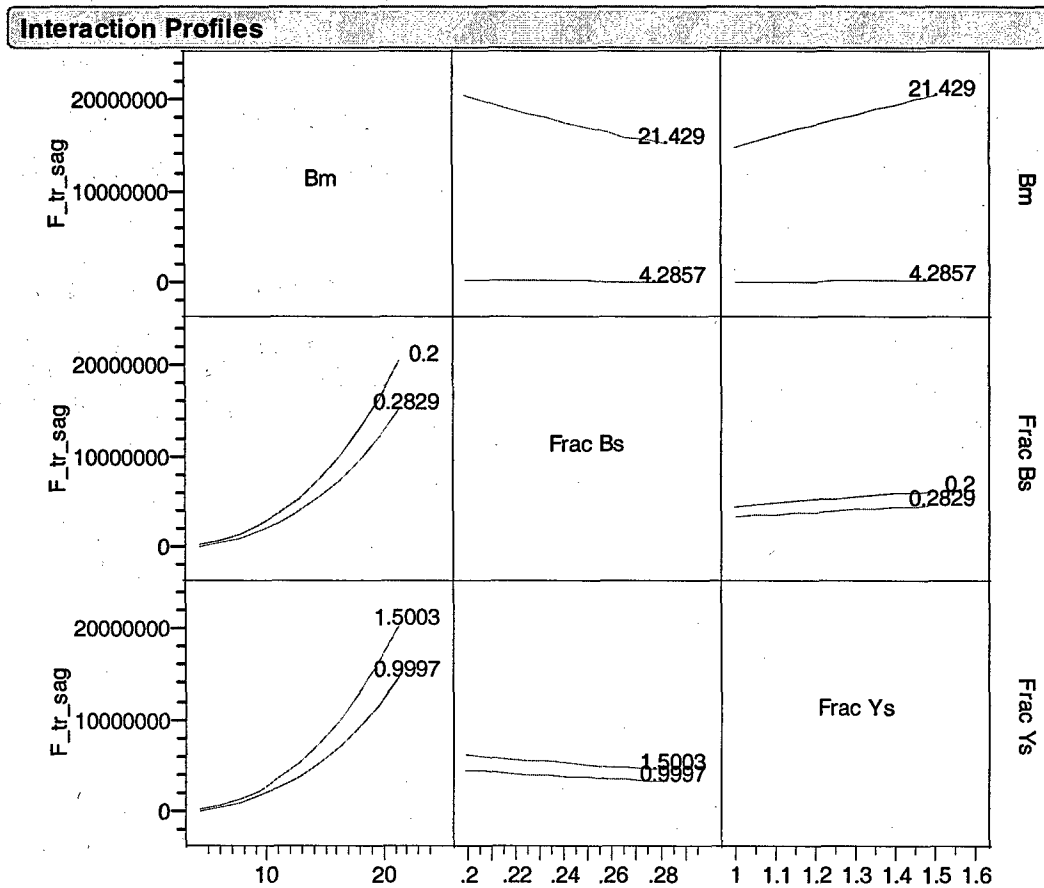

Figure 27 – Transverse Sagging Wave Side Hull Independent Variable Interaction

The partial fit equation shown for transverse sagging is shown equation (18) with the full equation shown in Appendix D.

$$\begin{aligned}
 F_{tr_sag} = & -7051000 + 951100B_m + -17730000\frac{B_s}{B_m} + 3046000\frac{Y_s}{B_m} + 55500(B_m - 12.86)^2 \dots \\
 & + -3537000\left(\frac{B_s}{B_m} - 0.2357\right) \cdot (B_m - 12.86) + 60540000\left(\frac{B_s}{B_m} - 0.2357\right)^2 \dots \\
 & + 592100(B_m - 12.86) \cdot \left(\frac{Y_s}{B_m} - 1.25\right) + -10590000\left(\frac{B_s}{B_m} - 0.2357\right) \cdot \left(\frac{Y_s}{B_m} - 1.25\right) \dots \\
 & + \text{third_order_terms} + \text{fourth_order_terms}
 \end{aligned}
 \tag{18}$$

5.1.6 Analytical Model Results for Transverse Hogging

A polynomial fit equation for the downward forces produced during transverse hogging was unable to be fitted to the data in Appendix B even using fourth order terms. This situation arises from the fact that there is a discontinuity in the downward force applied in a transverse hogging condition. When the transverse wave height is small enough that the outer hulls do not leave the water the loss of buoyancy due to wave height is linear. However, when the wave height becomes large enough, the side hulls leave the water and the loss of buoyancy after that point regardless of the wave height remains constant. Hence, a good fit for an overall downward force due to transverse hogging over a large range of values was not able to be found. Alternatively, the structural designer of a trimaran should design to the standard of the side hulls completely broaching the water as is discussed in references [5] through [10].

5.2 Comparison and Discussion of Analytical and MAESTRO Results

An example of the results of the MAESTRO structural analyses of the analytical force predictions compared to the full quasi-static linear wave theory balance analysis from 4.2.5 is shown below in Table 18 and Table 19 with the full results for all load cases and modules included in Appendix E through Appendix J.

Table 18 – Adequacy Parameters with analytically Predicted Forces (Longitudinal Troughing)

INITIAL PANEL ADEQUACY PARAMETER VALUES - MODULE 1 OF SUBSTR. 1

STRAKE	PCSF	PCCB	PCMY	PCSB	PYTF	PYTP	PYCF	PYCP	PSPBT	PSPBL	PFLB
1	0.826	0.938	0.927	0.933	1.000	1.000	0.965	0.965	1.000	1.000	0.807
2	0.883	0.978	0.939	0.913	1.000	1.000	0.945	0.945	1.000	1.000	0.882
3	0.971	0.996	0.986	0.985	1.000	1.000	0.990	0.990	1.000	1.000	0.923
4	0.939	0.990	0.955	0.991	0.998	0.998	0.995	0.995	1.000	1.000	0.932
5	0.979	1.000	0.983	1.000	1.000	1.000	1.000	1.000	1.000	1.000	0.979
6	0.957	0.988	0.976	0.994	1.000	1.000	0.996	0.996	1.000	1.000	0.901
7	0.913	0.990	0.940	1.000	1.000	1.000	1.000	1.000	1.000	1.000	0.906

Table 19 – Adequacy Parameters with MAESTRO Wave Balance (Longitudinal Troughing)

INITIAL PANEL ADEQUACY PARAMETER VALUES - MODULE 1 OF SUBSTR. 1

STRAKE	PCSF	PCCB	PCMY	PCSB	PYTF	PYTP	PYCF	PYCP	PSPBT	PSPBL	PFLB
1	0.848	0.943	0.937	0.939	1.000	1.000	0.969	0.969	1.000	1.000	0.831
2	0.898	0.980	0.944	0.918	1.000	1.000	0.948	0.948	1.000	1.000	0.897
3	0.972	0.997	0.988	0.986	1.000	1.000	0.991	0.991	1.000	1.000	0.940
4	0.949	0.987	0.964	0.991	1.000	1.000	0.995	0.995	1.000	1.000	0.944
5	0.977	1.000	0.983	1.000	1.000	1.000	1.000	1.000	1.000	1.000	0.977
6	0.967	0.986	0.983	0.995	1.000	1.000	0.997	0.997	1.000	1.000	0.923
7	0.918	0.967	0.945	1.000	1.000	1.000	1.000	1.000	1.000	1.000	0.908

Appendix E through Appendix J show the adequacy parameters for the panel and frame failure modes for each strake in the cross-deck structure from Figure 21. From the way that the adequacy parameter is defined, a lower adequacy parameter means that the evaluated strake is closer to failure for the analyzed failure mode.

Since a lower adequacy parameter means closer to failure, for the analytical model to be a conservative estimate of the cross-deck structural loading of the trimaran, every adequacy parameter for the analytical model must be less than the corresponding MAESTRO model adequacy parameter. While the adequacy parameters in Appendix E through Appendix J do

compare to a first order, the analytical model is not consistently the conservative estimate for every failure mode for every strake of the cross-deck structure.

The fact that the analytical model does not conservatively predict the failure adequacy parameters is not surprising. Many simplifications to the analytical model were made in order to make it possible to investigate the basic nature of global loading of the cross-deck structural forces experienced by trimarans over a large range of hull sizes and hull spacing configurations. The simplification most affecting the performance of the analytical model compared to the fully wave balanced MAESTRO model was the assumption that the hulls were rigid and rigidly connected. The hull deflections in the realistic fully wave balanced models were the primary source of the difference between the two models.

While it is unfortunate that the analytical model is not a truly conservative estimate of the cross-deck structural loading of trimarans for every loading case and failure mode, the results of the two methods did compare to a first order of magnitude with each other. Since the analytical model can predict forces to a first order of magnitude, it can be a useful tool for early stage design estimates of trimaran cross deck structural loading as functions of the basic hull parameters and dimensions restated again in Table 20 and Table 21.

Table 20 – Structural Loading from Sections 3.1.2, 3.1.3, and 3.1.4

FB_{lg}	the vertical force on cross-structure in longitudinal waves (troughing and cresting)
MB_{lg}	the moment on cross-structure in longitudinal waves (longitudinal twisting)
FB_{tr}	the vertical force in transverse waves (transverse hogging/sagging)

Table 21 – Relevant Trimaran Parameters Affecting Design Loading

B_m	the main hull's beam
L_m	the main hull's length
T_m	the main hull's draft
F_m	the main hull's freeboard (also side hull freeboard)
B_s	the side hull's beam
L_s	the side hull's length
T_s	the side hull's draft
X_s	the longitudinal position of the side hull wrt main hull amidships
Y_s	the transverse position of the side hull wrt main hull centerline

Since the goal of this work was to provide the trimaran designer with a way to estimate the cross-deck structural loading, this work is considered a qualified success.

Chapter 6 Conclusions

This main product of this work was the curve fits in Appendix D that predict trimaran cross-deck structure loading in applicable load cases of longitudinal troughing/cresting, longitudinal positive/negative twisting, and transverse hogging/sagging. These fitted curve of design loadings allows an initial design stage loading estimate for cross deck structural loading given general characteristics of length and spacing of a trimaran's hulls. The actual equations derived from the analytical model are useful for first approximations of loading to the cross-deck structure of a trimaran but are not necessarily always conservative. Flexure of the main hull of the trimaran is the main cause of the analytical model's un-conservative structural loading predictions.

A concurrent result of the fourth order polynomial fitted equations were the interaction profile plots shown in Figure 23 through Figure 27. The interaction profile plots show how the main design variables of the trimaran interact with each other to affect the cross-deck global structural loading. These plots are a useful visual qualitative tool to determine which trimaran configurations experience less cross-deck structural loading.

The fourth order polynomial curve fitted equations and the interaction profile plots combined with other characteristics of good trimaran design including stability, roll, and resistance characteristics will aid the trimaran ship designer in optimizing an overall trimaran ship design.

Chapter 7 Recommendations for Future Work

The first and probably most important area to continue further work in the area of trimaran cross-deck structural design would be to have an analytical model that accounted for forward speed effects of the ship moving through the water. While this is not extremely complicated to perform, it was not included in this work simply because MAESTRO does not have the capability verify the results, and the entire goal of this work was to derive an analytical model for cross-deck structural loading that could be compared with a more rigorous analysis such as finite element analysis.

An improvement to the analytical model in this work would be to account for side hull flare, slamming of waves into the cross deck structure, and incident waves encountered at oblique angles. Accounting for flare in the side hulls would be beneficial because both [1] and [19] reference the need to have side hull flare for stability and sea-keeping reasons. Using triangular side hulls instead of box barge side hulls would be a relatively simple correction to the analytical model and could be done to make side hull flare angle an additional parameter that could be varied while calculating design forces. Wave slamming of cross-deck structures and obliquely angled waves encounters on the other hand is more complicated and would require extensive modifications to the current analytical model.

Finally, general recommendations for study in the area of trimaran structural design in general would be to determine the dynamic whipping response of the relatively long and slender hulls that are characteristic of trimarans. An accompanying topic to the whipping response of slender hulls would be an investigation into active structural control to include the cost and power requirements for very high speed applications.

List of References

- [1] J. Zhang, "Design and Hydrodynamic Performance of Trimaran Displacement ships," PhD Thesis, Dept of Mechanical Engineering, University College London, 1997.
- [2] Unknown, "RV Trimaran Research Ship, United Kingdom", Naval Technology, [Online Journal] [cited 2003 August 14], Available HTTP <http://www.naval-technology.com/projects/trimaran/>
- [3] American Bureau of Shipping, Rules for Classing and Building Steel Vessels, Part 3. Houston, TX: ABS, 2000.
- [4] Det Norske Veritas, Rules for Classification, Steel Ships. Hovik, Norway: DNV, 1992.
- [5] M. W. Ash, "An Investigation of the Structural Efficiency of the Trimaran Hull Form," MSc. Naval Architecture Dissertation, Dept of Mechanical Engineering, University College London, 1993.
- [6] N. Putnam, "An Trimaran Structural Design," MSc. Naval Architecture Dissertation, Dept of Mechanical Engineering, University College London, 1995.
- [7] A. L. Spragg, "An Investigation of Trimaran Structural Efficiency," MSc. Naval Architecture Dissertation, Dept of Mechanical Engineering, University College London, 1995.
- [8] M. Selfridge, "Investigation of the Structural Efficiency of the Trimaran Hull Form," MSc. Naval Architecture Dissertation, Dept of Mechanical Engineering, University College London, 1996.
- [9] M. S. Khalid, "Investigation on Trimaran Box and Beam Under Transvere Load & Proposed Design Procedure," MSc. Naval Architecture Dissertation, Dept of Mechanical Engineering, University College London, 1998.

- [10] P. J. Kirk, "An Investigation into Low Weight Cross-Beams for Trimaran Ships," MSc. Naval Architecture Dissertation, Dept of Mechanical Engineering, University College London, 1999.
- [11] A. Francescutto, "On the Roll Motion of a Trimaran in Beam Waves," Proceedings of the Eleventh International Offshore and Polar Engineering Conference, vol. 3, pp. 321-325, 2001.
- [12] B. B. Ackers, T. J. Michael, O. W. Tredennick, H. C. Landen, E. R. Miller, J. P. Sodowsky, J. B. Hadler, "An Investigation of the Resistance Characteristics of Powered Trimaran Side-Hull Configurations," SNAME Transactions, vol. 105, pp. 349-373, 1997.
- [13] O. F. Hughes, Ship Structural Design: A Rationally-Based, Computer-Aided Optimization Approach. Jersey City, NJ: SNAME, 1988.
- [14] O. M. Faltinsen, Sea Load on Ships and Offshore Structures. New York, NY: Cambridge University Press, 1990.
- [15] E. V. Lewis, Principles of Naval Architecture, Vol III, Motions in Waves and Controllability. Jersey City, NJ: SNAME, 1989.
- [16] B. M. Ayyub, I. A. Assakkaf, J. P. Sikora, J.C. Adamchak, K. Atua, W. Melton, and P.E. Hess, "Reliability-Based Load and Resistance Factor Design (LRFD) Guideline for Hull Girder Bending," Naval Engineers Journal, vol 114, no 2, pp.43-68, 2002.
- [17] Naval Ship Engineering Center, Structural Design Manual for Naval Surface Ships, Washington, D.C.: Naval Sea Systems Command, 1976.
- [18] Naval Ship Engineering Center, DDS 100-6, Washington, D.C.: Naval Sea Systems Command, 1976.
- [19] J. L. Rhoads, C. Soultatis, D. Wolfson, "High Speed Corvette," Ship Design Project, Dept of Ocean Engineering, Massachusetts Institute of Technology, 2004.

[20] Optimum Structural Design, Inc., MAESTRO Modeler Manual, Stevensville, MD:

Optimum Structural Design, Inc., 1999.

Page Intentionally Left Blank

Appendix A. MathCAD Analytical Model

All the equations and formula required to complete the analytical model of the "box" trimaran are included in this Appendix. The essential explanations of the working of the analytical model are included in section 4.1.1. Where appropriate, each applicable section refers to the main text's explanation.

Explained in section 4.1.1.1

ss orig :=

	0	1	2	3	4	5	6	7	8	9	10	11	12	13	14	15	16	17	18	19	20	21	
0	0	0	0	0	0	0	0	0	0	0	0	0	0	0	0	0	0	0	0	0	0	0	
1	0.5	5.9·10 ⁻⁴	4.03·10 ⁻³	1.06·10 ⁻²	1.57·10 ⁻²	1.63·10 ⁻²	1.36·10 ⁻²	9.82·10 ⁻³	6.43·10 ⁻³	3.95·10 ⁻³	2.32·10 ⁻³	1.32·10 ⁻³	7.4·10 ⁻⁴	4.1·10 ⁻⁴	2.2·10 ⁻⁴	1.2·10 ⁻⁴	7·10 ⁻⁵	4·10 ⁻⁵	2·10 ⁻⁵	1·10 ⁻⁵	5·10 ⁻⁶	2·10 ⁻⁶	
2	1.5	9·10 ⁻⁵	2.12·10 ⁻³	1.23·10 ⁻²	3.22·10 ⁻²	5.11·10 ⁻²	5.81·10 ⁻²	5.28·10 ⁻²	4.1·10 ⁻²	2.85·10 ⁻²	1.82·10 ⁻²	1.1·10 ⁻²	6.34·10 ⁻³	3.55·10 ⁻³	1.94·10 ⁻³	1.05·10 ⁻³	5.8·10 ⁻⁴	3·10 ⁻⁴	1.6·10 ⁻⁴	8·10 ⁻⁵	4·10 ⁻⁵	2·10 ⁻⁵	
3	2.5	0	8·10 ⁻⁵	1.46·10 ⁻³	8.31·10 ⁻³	2.29·10 ⁻²	3.9·10 ⁻²	4.71·10 ⁻²	4.46·10 ⁻²	3.53·10 ⁻²	2.45·10 ⁻²	1.54·10 ⁻²	9.01·10 ⁻³	4.97·10 ⁻³	2.63·10 ⁻³	1.35·10 ⁻³	6.7·10 ⁻⁴	3.3·10 ⁻⁴	1.6·10 ⁻⁴	8·10 ⁻⁵	4·10 ⁻⁵	2·10 ⁻⁵	
4	3.5	0	0	6·10 ⁻⁵	8.5·10 ⁻⁴	4.81·10 ⁻³	1.37·10 ⁻²	2.41·10 ⁻²	2.96·10 ⁻²	2.8·10 ⁻²	2.16·10 ⁻²	1.44·10 ⁻²	8.49·10 ⁻³	4.58·10 ⁻³	2.31·10 ⁻³	1.1·10 ⁻³	5·10 ⁻⁴	2.2·10 ⁻⁴	1·10 ⁻⁴	5·10 ⁻⁵	2·10 ⁻⁵	1·10 ⁻⁵	
5	4.5	0	0	0	4·10 ⁻⁵	5.7·10 ⁻⁴	3.15·10 ⁻³	8.98·10 ⁻³	1.56·10 ⁻²	1.88·10 ⁻²	1.7·10 ⁻²	1.23·10 ⁻²	7.48·10 ⁻³	3.98·10 ⁻³	1.91·10 ⁻³	8.4·10 ⁻⁴	3.5·10 ⁻⁴	1.3·10 ⁻⁴	5·10 ⁻⁵	2·10 ⁻⁵	1·10 ⁻⁵	5·10 ⁻⁶	
6	5.5	0	0	0	0	3·10 ⁻⁵	3.9·10 ⁻⁴	2.07·10 ⁻³	5.71·10 ⁻³	9.5·10 ⁻³	1.07·10 ⁻²	8.85·10 ⁻³	5.75·10 ⁻³	3.09·10 ⁻³	1.42·10 ⁻³	5.8·10 ⁻⁴	2.1·10 ⁻⁴	7·10 ⁻⁵	2·10 ⁻⁵	1·10 ⁻⁵	5·10 ⁻⁶	2·10 ⁻⁶	
7	6.5	0	0	0	0	0	2·10 ⁻⁵	2.7·10 ⁻⁴	1.36·10 ⁻³	3.47·10 ⁻³	5.28·10 ⁻³	5.33·10 ⁻³	3.87·10 ⁻³	2.17·10 ⁻³	9.8·10 ⁻⁴	3.7·10 ⁻⁴	1.2·10 ⁻⁴	4·10 ⁻⁵	1·10 ⁻⁵	5·10 ⁻⁶	2·10 ⁻⁶	1·10 ⁻⁶	
8	7.5	0	0	0	0	0	0	2·10 ⁻⁵	2·10 ⁻⁴	8.8·10 ⁻⁴	1.97·10 ⁻³	2.61·10 ⁻³	2.26·10 ⁻³	1.38·10 ⁻³	6.4·10 ⁻⁴	2.3·10 ⁻⁴	7·10 ⁻⁵	2·10 ⁻⁵	1·10 ⁻⁵	5·10 ⁻⁶	2·10 ⁻⁶	1·10 ⁻⁶	
9	8.5	0	0	0	0	0	0	0	2·10 ⁻⁵	1.5·10 ⁻⁴	5.4·10 ⁻⁴	1.01·10 ⁻³	1.11·10 ⁻³	7.8·10 ⁻⁴	3.9·10 ⁻⁴	1.4·10 ⁻⁴	4·10 ⁻⁵	1·10 ⁻⁵	5·10 ⁻⁶	2·10 ⁻⁶	1·10 ⁻⁶	5·10 ⁻⁷	
10	9.5	0	0	0	0	0	0	0	0	1.1·10 ⁻⁴	3·10 ⁻⁴	4.5·10 ⁻⁴	3.9·10 ⁻⁴	2.2·10 ⁻⁴	8·10 ⁻⁵	2·10 ⁻⁵	1·10 ⁻⁵	5·10 ⁻⁶	2·10 ⁻⁶	1·10 ⁻⁶	5·10 ⁻⁷	2·10 ⁻⁷	
11	10.5	0	0	0	0	0	0	0	0	2·10 ⁻⁵	7·10 ⁻⁵	1.5·10 ⁻⁴	1.6·10 ⁻⁴	1.1·10 ⁻⁴	5·10 ⁻⁵	1·10 ⁻⁵	5·10 ⁻⁶	2·10 ⁻⁶	1·10 ⁻⁶	5·10 ⁻⁷	2·10 ⁻⁷	1·10 ⁻⁷	
12	11.5	0	0	0	0	0	0	0	0	0	10 ⁻⁶	4·10 ⁻⁶	6·10 ⁻⁶	5·10 ⁻⁶	2·10 ⁻⁶	1·10 ⁻⁶	5·10 ⁻⁷	2·10 ⁻⁷	1·10 ⁻⁷	5·10 ⁻⁸	2·10 ⁻⁸	1·10 ⁻⁸	
13	12.5	0	0	0	0	0	0	0	0	0	0	10 ⁻⁶	2·10 ⁻⁶	2·10 ⁻⁶	10 ⁻⁶	5·10 ⁻⁷	2·10 ⁻⁷	1·10 ⁻⁷	5·10 ⁻⁸	2·10 ⁻⁸	1·10 ⁻⁸	5·10 ⁻⁹	
14	13.5	0	0	0	0	0	0	0	0	0	0	0	0	10 ⁻⁶	0	0	0	0	0	0	0	0	
15	14.5	0	0	0	0	0	0	0	0	0	0	0	0	0	0	0	0	0	0	0	0	0	
16																							

Explained in section 4.1.1.2

$$B := (\text{rows}(\text{ss orig}) - 1)$$

$$D := (\text{cols}(\text{ss orig}) - 1)$$

$$t := 1..2B$$

$$r := 1..D$$

$$T_{\lambda} := \text{submatrix}(\text{ss orig}, 0, 0, 0, 19)^T \cdot \text{sec}$$

$$h_{w_t} := (t - .5) \cdot m$$

$$\lambda_r := \frac{g}{2\pi} \cdot (T_{\lambda_r})^2$$

(This equation explained in Section 4.1.1.3)

$$P_{\text{ray}}(H, t) := 4 \cdot \frac{H}{(h_{w_t})^2} \cdot e^{-2 \cdot \left[\frac{H^2}{(h_{w_t})^2} \right]}$$

```

ss := new2,B,D ← 0
for q ∈ 1..D
  for p ∈ 1..B
    if ssorigp,q ≠ 0
      for n ∈ 1..2·p
        tmp ← ssorigp,q ∫hwn - 0.5·mhwn + 0.5·m pray(H,p) dH
        newn,q ← newn,q + tmp
      0
    new

```

	0	1	2	3	4	5	6	7	8	9	10	11	12	13	14	15	16	17	18	19
0	0	0	0	0	0	0	0	0	0	0	0	0	0	0	0	0	0	0	0	0
1	0	6.43·10 ⁻⁴	5.3·10 ⁻³	1.83·10 ⁻²	3.71·10 ⁻²	5.35·10 ⁻²	6.09·10 ⁻²	5.84·10 ⁻²	4.82·10 ⁻²	3.72·10 ⁻²	2.56·10 ⁻²	1.63·10 ⁻²	9.59·10 ⁻³	5.31·10 ⁻³	2.79·10 ⁻³	1.42·10 ⁻³	7.15·10 ⁻⁴	3.6·10 ⁻⁴	1.8·10 ⁻⁴	1.75·10 ⁻⁴
2	0	3.48·10 ⁻⁵	8.49·10 ⁻⁴	5.33·10 ⁻³	1.83·10 ⁻²	3.15·10 ⁻²	4.5·10 ⁻²	5.17·10 ⁻²	5.02·10 ⁻²	4.24·10 ⁻²	3.17·10 ⁻²	2.12·10 ⁻²	1.28·10 ⁻²	7.04·10 ⁻³	3.6·10 ⁻³	1.75·10 ⁻³	8.23·10 ⁻⁴	3.85·10 ⁻⁴	1.82·10 ⁻⁴	1.84·10 ⁻⁴
3	0	2.54·10 ⁻⁶	7.78·10 ⁻⁵	6.89·10 ⁻⁴	3.01·10 ⁻³	6.09·10 ⁻³	1.52·10 ⁻²	2.18·10 ⁻²	2.52·10 ⁻²	2.45·10 ⁻²	2.03·10 ⁻²	1.45·10 ⁻²	9.03·10 ⁻³	4.96·10 ⁻³	2.46·10 ⁻³	1.12·10 ⁻³	4.88·10 ⁻⁴	2.07·10 ⁻⁴	8.83·10 ⁻⁵	6.84·10 ⁻⁵
4	0	3.01·10 ⁻⁷	4.72·10 ⁻⁶	8.88·10 ⁻⁵	5.99·10 ⁻⁴	2.05·10 ⁻³	4.85·10 ⁻³	8.47·10 ⁻³	1.15·10 ⁻²	1.28·10 ⁻²	1.17·10 ⁻²	8.94·10 ⁻³	5.79·10 ⁻³	3.21·10 ⁻³	1.56·10 ⁻³	6.72·10 ⁻⁴	2.7·10 ⁻⁴	1.05·10 ⁻⁴	3.99·10 ⁻⁵	2.67·10 ⁻⁵
5	0	0	4.51·10 ⁻⁷	1.16·10 ⁻⁵	9.97·10 ⁻⁵	4.75·10 ⁻⁴	1.44·10 ⁻³	3.08·10 ⁻³	4.96·10 ⁻³	6.26·10 ⁻³	6.34·10 ⁻³	5.23·10 ⁻³	3.55·10 ⁻³	2.10 ⁻³	9.6·10 ⁻⁴	3.98·10 ⁻⁴	1.48·10 ⁻⁴	5.32·10 ⁻⁵	1.74·10 ⁻⁵	10·10 ⁻⁵
6	0	0	2.6·10 ⁻⁸	1.32·10 ⁻⁶	1.69·10 ⁻⁵	1.1·10 ⁻⁴	4.23·10 ⁻⁴	1.1·10 ⁻³	2.07·10 ⁻³	2.97·10 ⁻³	3.33·10 ⁻³	2.96·10 ⁻³	2.12·10 ⁻³	1.23·10 ⁻³	5.87·10 ⁻⁴	2.34·10 ⁻⁴	8.18·10 ⁻⁵	2.78·10 ⁻⁵	7.49·10 ⁻⁶	3.71·10 ⁻⁶
7	0	0	0	1.48·10 ⁻⁷	2.92·10 ⁻⁶	2.52·10 ⁻⁵	1.21·10 ⁻⁴	3.8·10 ⁻⁴	8.37·10 ⁻⁴	1.36·10 ⁻³	1.69·10 ⁻³	1.63·10 ⁻³	1.23·10 ⁻³	7.33·10 ⁻⁴	3.57·10 ⁻⁴	1.39·10 ⁻⁴	4.57·10 ⁻⁵	1.46·10 ⁻⁵	3.18·10 ⁻⁶	1.33·10 ⁻⁶
8	0	0	0	1.84·10 ⁻⁸	5.05·10 ⁻⁷	5.7·10 ⁻⁶	3.41·10 ⁻⁵	1.28·10 ⁻⁴	3.3·10 ⁻⁴	6.1·10 ⁻⁴	8.4·10 ⁻⁴	8.78·10 ⁻⁴	7.07·10 ⁻⁴	4.39·10 ⁻⁴	2.16·10 ⁻⁴	8.29·10 ⁻⁵	2.59·10 ⁻⁵	7.88·10 ⁻⁶	1.33·10 ⁻⁶	4.51·10 ⁻⁷
9	0	0	0	0	5.65·10 ⁻⁸	1.13·10 ⁻⁶	8.97·10 ⁻⁶	4.16·10 ⁻⁵	1.28·10 ⁻⁴	2.65·10 ⁻⁴	4.07·10 ⁻⁴	4.63·10 ⁻⁴	3.98·10 ⁻⁴	2.58·10 ⁻⁴	1.3·10 ⁻⁴	4.93·10 ⁻⁵	1.48·10 ⁻⁵	4.28·10 ⁻⁶	5.37·10 ⁻⁷	1.42·10 ⁻⁷
10	0	0	0	0	1.14·10 ⁻⁸	2.63·10 ⁻⁷	2.47·10 ⁻⁶	1.36·10 ⁻⁵	4.78·10 ⁻⁵	1.14·10 ⁻⁴	1.84·10 ⁻⁴	2.4·10 ⁻⁴	2.21·10 ⁻⁴	1.5·10 ⁻⁴	7.84·10 ⁻⁵	2.95·10 ⁻⁵	8.58·10 ⁻⁶	2.34·10 ⁻⁶	2.1·10 ⁻⁷	4.23·10 ⁻⁸
11	0	0	0	0	3.03·10 ⁻⁹	5.04·10 ⁻⁷	3.89·10 ⁻⁶	1.89·10 ⁻⁵	4.7·10 ⁻⁵	9.01·10 ⁻⁵	1.22·10 ⁻⁴	1.21·10 ⁻⁴	8.65·10 ⁻⁵	4.89·10 ⁻⁵	1.76·10 ⁻⁵	4.96·10 ⁻⁶	1.28·10 ⁻⁶	7.56·10 ⁻⁷	1.01·10 ⁻⁸	0
12	0	0	0	0	7.88·10 ⁻⁹	1.45·10 ⁻⁷	1.28·10 ⁻⁶	6.29·10 ⁻⁶	1.97·10 ⁻⁵	4.18·10 ⁻⁵	6.16·10 ⁻⁵	6.57·10 ⁻⁵	4.95·10 ⁻⁵	2.8·10 ⁻⁵	1.06·10 ⁻⁵	2.9·10 ⁻⁶	6.95·10 ⁻⁷	2.68·10 ⁻⁸	2.62·10 ⁻⁹	0
13	0	0	0	0	1.52·10 ⁻⁸	2.78·10 ⁻⁷	1.92·10 ⁻⁶	7.48·10 ⁻⁶	1.84·10 ⁻⁵	3.01·10 ⁻⁵	3.49·10 ⁻⁵	3.49·10 ⁻⁵	2.78·10 ⁻⁵	1.69·10 ⁻⁵	6.27·10 ⁻⁶	1.88·10 ⁻⁶	3.98·10 ⁻⁷	7.6·10 ⁻⁸	0	0
14	0	0	0	0	4.84·10 ⁻⁹	9.57·10 ⁻⁸	7.3·10 ⁻⁷	3.12·10 ⁻⁶	8.44·10 ⁻⁶	1.49·10 ⁻⁵	1.87·10 ⁻⁵	1.57·10 ⁻⁵	9.82·10 ⁻⁶	3.73·10 ⁻⁶	9.84·10 ⁻⁷	1.95·10 ⁻⁷	2.42·10 ⁻⁸	0	0	0
15	0	0	0	0	0	1.21·10 ⁻⁸	1.7·10 ⁻⁷	1.02·10 ⁻⁶	3.42·10 ⁻⁶	6.88·10 ⁻⁶	9.57·10 ⁻⁶	8.81·10 ⁻⁶	5.71·10 ⁻⁶	2.18·10 ⁻⁶	5.63·10 ⁻⁷	9.8·10 ⁻⁸	0	0	0	0
16	0	0	0	0	0	4.48·10 ⁻⁹	6.75·10 ⁻⁸	4.36·10 ⁻⁷	1.57·10 ⁻⁶	3.38·10 ⁻⁶	5.07·10 ⁻⁶	4.8·10 ⁻⁶	3.37·10 ⁻⁶	1.26·10 ⁻⁶	3.26·10 ⁻⁷	4.98·10 ⁻⁸	0	0	0	0
17	0	0	0	0	0	0	1·10 ⁻⁸	1.11·10 ⁻⁷	5.53·10 ⁻⁷	1.43·10 ⁻⁶	2.47·10 ⁻⁶	2.53·10 ⁻⁶	1.92·10 ⁻⁶	7.23·10 ⁻⁷	1.81·10 ⁻⁷	2.28·10 ⁻⁸	0	0	0	0
18	0	0	0	0	0	0	4.16·10 ⁻⁹	4.91·10 ⁻⁸	2.6·10 ⁻⁷	7.04·10 ⁻⁷	1.3·10 ⁻⁶	1.4·10 ⁻⁶	1.12·10 ⁻⁶	4.18·10 ⁻⁷	1.03·10 ⁻⁷	1.1·10 ⁻⁸	0	0	0	0
19	0	0	0	0	0	0	0	8.52·10 ⁻⁹	7.43·10 ⁻⁸	2.56·10 ⁻⁷	5.85·10 ⁻⁷	6.96·10 ⁻⁷	6.19·10 ⁻⁷	2.29·10 ⁻⁷	5.41·10 ⁻⁸	4.26·10 ⁻⁹	0	0	0	0
20	0	0	0	0	0	0	0	3.88·10 ⁻⁹	3.59·10 ⁻⁸	1.28·10 ⁻⁷	3.11·10 ⁻⁷	3.83·10 ⁻⁷	3.61·10 ⁻⁷	1.28·10 ⁻⁷	3.01·10 ⁻⁸	1.94·10 ⁻⁹	0	0	0	0
21	0	0	0	0	0	0	0	7.41·10 ⁻⁹	3.88·10 ⁻⁸	1.24·10 ⁻⁷	1.73·10 ⁻⁷	1.89·10 ⁻⁷	1.48·10 ⁻⁷	4.47·10 ⁻⁸	1.48·10 ⁻⁸	0	0	0	0	0
22	0	0	0	0	0	0	0	3.63·10 ⁻⁹	1.88·10 ⁻⁸	6.85·10 ⁻⁸	9.54·10 ⁻⁸	1.1·10 ⁻⁷	3.62·10 ⁻⁸	7.89·10 ⁻⁹	0	0	0	0	0	0
23	0	0	0	0	0	0	0	3.27·10 ⁻⁹	2.2·10 ⁻⁸	3.75·10 ⁻⁸	5.34·10 ⁻⁸	1.55·10 ⁻⁸	3.27·10 ⁻⁹	0	0	0	0	0	0	0
24	0	0	0	0	0	0	0	1.71·10 ⁻⁹	1.2·10 ⁻⁸	2.06·10 ⁻⁸	3.1·10 ⁻⁸	8.6·10 ⁻⁹	1.71·10 ⁻⁹	0	0	0	0	0	0	0
25	0	0	0	0	0	0	0	0	2.93·10 ⁻⁹	5.85·10 ⁻⁹	1.33·10 ⁻⁸	2.83·10 ⁻⁹	0	0	0	0	0	0	0	0
26	0	0	0	0	0	0	0	0	1.61·10 ⁻⁹	3.22·10 ⁻⁹	7.72·10 ⁻⁹	1.61·10 ⁻⁹	0	0	0	0	0	0	0	0
27	0	0	0	0	0	0	0	0	0	0	0	2.65·10 ⁻⁹	0	0	0	0	0	0	0	0
28	0	0	0	0	0	0	0	0	0	0	0	1.52·10 ⁻⁹	0	0	0	0	0	0	0	0
29	0	0	0	0	0	0	0	0	0	0	0	0	0	0	0	0	0	0	0	0

```

pmax := for q ∈ 1..D
        for p ∈ 1..2B
          tmp ← p if ssp,q ≠ 0
          pmaxq ← tmp
        pmax

```

Explained in Section 4.1.1.3

$$H_{\text{wave_lg}}(x, p, q, \phi, X_s) := \frac{h_{w_p}}{2} \cdot \sin \left[\frac{2\pi}{\lambda_q} \cdot (x - X_s) - \phi \right]$$

$$\phi_{\text{lg}} := \begin{pmatrix} 0 \\ 90 \\ 180 \\ 270 \end{pmatrix} \cdot \text{deg} \quad \phi_{\text{lg}} = \begin{pmatrix} \text{pos_twist} \\ \text{trough} \\ \text{neg_twist} \\ \text{crest} \end{pmatrix}$$

$$H_{\text{wave_tr}}(y, p, q, \phi) := \frac{h_w p}{2} \cdot \cos \left[\frac{2 \cdot \pi}{\lambda_q} \cdot (y) - \phi \right]$$

$$\phi_{\text{tr}} := \begin{pmatrix} 0 \\ 180 \end{pmatrix} \cdot \text{deg}$$

$$\phi_{\text{tr}} = \begin{pmatrix} \text{hog} \\ \text{sag} \end{pmatrix}$$

Explained in Section 4.1.1.4

```

motion_lg(p, q, phi, X_s, X_cf, T_s, L_s, B_s, F_m, T_m, B_m, L_m) :=
  Delta T <- 0 m
  Theta_pitch <- 0
  Delta P <- 1 m^4
  Delta V <- 1 m^3
  count <- 0
  while (|Delta V| > 10^-3 m^3) v (|Delta P| > 10^-3 m^4)
  Delta V <- B_m * integral(
    from -L_m/2 to L_m/2
    of [ F_m if [H_wave_lg(x, p, q, phi, X_s) - Delta T - (x - X_cf) * sin(Theta_pitch)] > F_m
        -T_m if [H_wave_lg(x, p, q, phi, X_s) - Delta T - (x - X_cf) * sin(Theta_pitch)] < -T_m
        [H_wave_lg(x, p, q, phi, X_s) - Delta T - (x - X_cf) * sin(Theta_pitch)] otherwise ] dx ...
    + 2 * B_s * integral(
      from X_s/2 to X_s/2 + L_s/2
      of [ F_m if [H_wave_lg(x, p, q, phi, X_s) - Delta T - (x - X_cf) * sin(Theta_pitch)] > F_m
          -T_s if [H_wave_lg(x, p, q, phi, X_s) - Delta T - (x - X_cf) * sin(Theta_pitch)] < -T_s
          [H_wave_lg(x, p, q, phi, X_s) - Delta T - (x - X_cf) * sin(Theta_pitch)] otherwise ] dx
    )
  Delta P <- B_m * integral(
    from -L_m/2 to L_m/2
    of [ F_m if [H_wave_lg(x, p, q, phi, X_s) - Delta T - (x - X_cf) * sin(Theta_pitch)] > F_m
        -T_m if [H_wave_lg(x, p, q, phi, X_s) - Delta T - (x - X_cf) * sin(Theta_pitch)] < -T_m
        [H_wave_lg(x, p, q, phi, X_s) - Delta T - (x - X_cf) * sin(Theta_pitch)] otherwise ] * (x - X_cf) dx ...
    + 2 * B_s * integral(
      from X_s/2 to X_s/2 + L_s/2
      of [ F_m if [H_wave_lg(x, p, q, phi, X_s) - Delta T - (x - X_cf) * sin(Theta_pitch)] > F_m
          -T_s if [H_wave_lg(x, p, q, phi, X_s) - Delta T - (x - X_cf) * sin(Theta_pitch)] < -T_s
          [H_wave_lg(x, p, q, phi, X_s) - Delta T - (x - X_cf) * sin(Theta_pitch)] otherwise ] * (x - X_cf) dx
    )
  tmp1 <- Delta V / (B_m * L_m + 2 * B_s * L_s)
  tmp2 <- Delta P / (B_m * (L_m/2)^3)
  Delta T <- Delta T + tmp1
  Theta_pitch <- Theta_pitch + tmp2
  count <- count + 1
  M <- (
    Delta T / m
    Theta_pitch
  )
  if count >= 100
  | M <- motion_lg(p - 1, q, phi, X_s, X_cf, T_s, L_s, B_s, F_m, T_m, B_m, L_m)
  | break
M

```

$$\text{motion_tr}(p, q, \phi, Y_s, T_s, L_s, B_s, F_m, T_m, B_m, L_m) := \left[\begin{array}{l}
\Delta T \leftarrow 0 \cdot m \\
\Delta V \leftarrow 1 \cdot m^3 \\
\text{count} \leftarrow 0 \\
\text{while } (|\Delta V| > 10^{-3} \cdot m^3) \\
\left[\begin{array}{l}
\Delta V \leftarrow L_m \cdot \int_{-\frac{B_m}{2}}^{\frac{B_m}{2}} \left[\begin{array}{l}
F_m \text{ if } (H_{\text{wave_tr}}(y, p, q, \phi) - \Delta T) > F_m \text{ dy} \dots \\
-T_m \text{ if } (H_{\text{wave_tr}}(y, p, q, \phi) - \Delta T) < -T_m \\
(H_{\text{wave_tr}}(y, p, q, \phi) - \Delta T) \text{ otherwise}
\end{array} \right. \\
+ 2 \cdot L_s \cdot \int_{Y_s - \frac{B_s}{2}}^{Y_s + \frac{B_s}{2}} \left[\begin{array}{l}
F_m \text{ if } (H_{\text{wave_tr}}(y, p, q, \phi) - \Delta T) > F_m \text{ dy} \\
-T_s \text{ if } (H_{\text{wave_tr}}(y, p, q, \phi) - \Delta T) < -T_s \\
(H_{\text{wave_tr}}(y, p, q, \phi) - \Delta T) \text{ otherwise}
\end{array} \right. \\
\text{tmp1} \leftarrow \frac{\Delta V}{B_m \cdot L_m + 2 \cdot B_s \cdot L_s} \\
\Delta T \leftarrow \Delta T + \text{tmp1} \\
M \leftarrow \frac{\Delta T}{m} \\
\text{count} \leftarrow \text{count} + 1 \\
\text{if count} \geq 100 \\
\left[\begin{array}{l}
M \leftarrow \text{motion_tr}(p - 1, q, \phi, Y_s, T_s, L_s, B_s, F_m, T_m, B_m, L_m) \\
\text{break}
\end{array} \right.
\end{array} \right. \\
M
\end{array} \right.$$

Explained in Section 4.1.1.5

$$\text{FB}_{lg}(p, q, \phi, X_s, X_{cf}, T_s, L_s, B_s, F_m, T_m, B_m, L_m) := \left[\begin{array}{l}
\text{mot} \leftarrow \text{motion}_{lg}(p, q, \phi, X_s, X_{cf}, T_s, L_s, B_s, F_m, T_m, B_m, L_m) \\
\Delta T \leftarrow \text{mot}_0 \cdot m \\
\Theta_{\text{pitch}} \leftarrow \text{mot}_1 \\
\text{FB}_s \leftarrow \frac{1 \text{ton}}{35 \cdot \text{ft}^3} \cdot B_s \cdot \int_{X_s - \frac{L_s}{2}}^{X_s + \frac{L_s}{2}} \left[\begin{array}{l}
F_m \text{ if } [H_{\text{wave}_{lg}}(x, p, q, \phi, X_s) - \Delta T - (x - X_{cf}) \cdot \sin(\Theta_{\text{pitch}})] > F_m \\
-T_s \text{ if } [H_{\text{wave}_{lg}}(x, p, q, \phi, X_s) - \Delta T - (x - X_{cf}) \cdot \sin(\Theta_{\text{pitch}})] < -T_s \\
[H_{\text{wave}_{lg}}(x, p, q, \phi, X_s) - \Delta T - (x - X_{cf}) \cdot \sin(\Theta_{\text{pitch}})] \text{ otherwise}
\end{array} \right] dx \\
\text{FB}_s
\end{array} \right.$$

$$\begin{array}{l}
 \text{MB}_{lg}(p, q, \phi, X_s, X_{cf}, T_s, L_s, B_s, F_m, T_m, B_m, L_m) := \left[\begin{array}{l}
 \text{mot} \leftarrow \text{motion}_{lg}(p, q, \phi, X_s, X_{cf}, T_s, L_s, B_s, F_m, T_m, B_m, L_m) \\
 \Delta T \leftarrow \text{mot}_0 \cdot m \\
 \Theta_{pitch} \leftarrow \text{mot}_1 \\
 \text{MB}_s \leftarrow \frac{\text{lton}}{35\text{-ft}^3} \left[B_s \cdot \int_{X_s - \frac{L_s}{2}}^{X_s + \frac{L_s}{2}} \left[\begin{array}{l}
 F_m \text{ if } [H_{\text{wave}_{lg}}(x, p, q, \phi, X_s) - \Delta T - (x - X_{cf}) \cdot \sin(\Theta_{pitch})] > F_m \\
 -T_s \text{ if } [H_{\text{wave}_{lg}}(x, p, q, \phi, X_s) - \Delta T - (x - X_{cf}) \cdot \sin(\Theta_{pitch})] < -T_s \\
 [H_{\text{wave}_{lg}}(x, p, q, \phi, X_s) - \Delta T - (x - X_{cf}) \cdot \sin(\Theta_{pitch})] \text{ otherwise}
 \end{array} \right] \cdot (x - X_s) dx \\
 \text{MB}_s
 \end{array} \right]
 \end{array}$$

$$\begin{array}{l}
 \text{FB}_{tr}(p, q, \phi, Y_s, T_s, L_s, B_s, F_m, T_m, B_m, L_m) := \left[\begin{array}{l}
 \text{mot} \leftarrow \text{motion}_{tr}(p, q, \phi, Y_s, T_s, L_s, B_s, F_m, T_m, B_m, L_m) \\
 \Delta T \leftarrow \text{mot} \cdot m \\
 \text{FB}_s \leftarrow \frac{\text{lton}}{35\text{-ft}^3} \left[L_s \cdot \int_{Y_s - \frac{B_s}{2}}^{Y_s + \frac{B_s}{2}} \left[\begin{array}{l}
 F_m \text{ if } (H_{\text{wave}_{tr}}(y, p, q, \phi) - \Delta T) > F_m \\
 -T_s \text{ if } (H_{\text{wave}_{tr}}(y, p, q, \phi) - \Delta T) < -T_s \\
 (H_{\text{wave}_{tr}}(y, p, q, \phi) - \Delta T) \text{ otherwise}
 \end{array} \right] dy \\
 \text{FB}_s
 \end{array} \right]
 \end{array}$$

Explained in Section 4.1.1.6

$\beta := 5$

$$\begin{array}{l}
 \text{dmax}_{lg}(L_m) := \left[\begin{array}{l}
 \text{dmax} \leftarrow 0 \\
 \text{for } n \in 1..D \\
 \quad \text{dmax} \leftarrow n \text{ if } \lambda_n < L_m \\
 \text{dmax} \leftarrow \text{dmax} + 3
 \end{array} \right]
 \end{array}$$

$$\begin{array}{l}
 \text{q}_{lg_sag_FB}(X_s, X_{cf}, T_s, L_s, B_s, F_m, T_m, B_m, L_m) := \left[\begin{array}{l}
 q_{max} \leftarrow 0 \\
 F \leftarrow 0 \\
 \text{for } q \in 1.. \text{dmax}_{lg}(L_m) \\
 \quad \left[\begin{array}{l}
 p \leftarrow p_{max}_q \\
 \text{Ftemp} \leftarrow \left| \text{FB}_{lg}(p, q, \phi_{lg1}, X_s, X_{cf}, T_s, L_s, B_s, F_m, T_m, B_m, L_m) \right| \\
 \text{if } \text{Ftemp} > F \\
 \quad \left[\begin{array}{l}
 q_{max} \leftarrow q \\
 F \leftarrow \text{Ftemp}
 \end{array} \right]
 \end{array} \right] \\
 q_{max}
 \end{array} \right]
 \end{array}$$

```

design_lg_sag_FB_s(X_s, X_cf, T_s, L_s, B_s, F_m, T_m, B_m, L_m) :=
  mean ← 0
  m2 ← 0
  design ← 0
  q ← q_lg_sag_FB(X_s, X_cf, T_s, L_s, B_s, F_m, T_m, B_m, L_m)
  sum ← ∑_{p=1}^{pmax_q} ss_{p,q}
  for p ∈ 1..pmax_q
    if ss_{p,q} ≠ 0
      F ← FB_lg(p, q, φ_lg1, X_s, X_cf, T_s, L_s, B_s, F_m, T_m, B_m, L_m)
      mean ← mean + |F| ·  $\frac{ss_{p,q}}{sum}$ 
      m2 ← m2 + (F)2 ·  $\frac{ss_{p,q}}{sum}$ 
  design ← -[mean + β · √(m2 - (mean)2)]
  design

```

```

q_lg_hog_FB(X_s, X_cf, T_s, L_s, B_s, F_m, T_m, B_m, L_m) :=
  q_max ← 0
  F ← 0
  for q ∈ 1..dmax_lg(L_m)
    p ← pmax_q
    Ftemp ← |FB_lg(p, q, φ_lg3, X_s, X_cf, T_s, L_s, B_s, F_m, T_m, B_m, L_m)|
    if Ftemp > F
      q_max ← q
      F ← Ftemp
  q_max

```

```

design_lg_hog_FB (Xs, Xcf, Ts, Ls, Bs, Fm, Tm, Bm, Lm) :=
  mean ← 0
  m2 ← 0
  design ← 0
  q ← q_lg_hog_FB (Xs, Xcf, Ts, Ls, Bs, Fm, Tm, Bm, Lm)
  sum ← ∑p=1pmaxq ssp,q
  for p ∈ 1..pmaxq
    if ssp,q ≠ 0
      F ← FBlg(p, q, φlg3, Xs, Xcf, Ts, Ls, Bs, Fm, Tm, Bm, Lm)
      mean ← mean + |F| ·  $\frac{ss_{p,q}}{sum}$ 
      m2 ← m2 + (F)2 ·  $\frac{ss_{p,q}}{sum}$ 
  design ← mean + β · √(m2 - (mean)2)
  design

```

```

q_twist_MB_pos (Xs, Xcf, Ts, Ls, Bs, Fm, Tm, Bm, Lm) :=
  qmax ← 0
  F ← 0
  for q ∈ 1..dmaxlg(Lm)
    p ← pmaxq
    Ftemp ← |MBlg(p, q, φlg0, Xs, Xcf, Ts, Ls, Bs, Fm, Tm, Bm, Lm)|
    if Ftemp > F
      qmax ← q
      F ← Ftemp
  qmax

```

```

design_twist_MB_pos (Xs, Xcf, Ts, Ls, Bs, Fm, Tm, Bm, Lm) :=
  mean ← 0
  m2 ← 0
  design ← 0
  q ← q_twist_MB_pos (Xs, Xcf, Ts, Ls, Bs, Fm, Tm, Bm, Lm)
  sum ← ∑p=1pmaxq ssp,q
  for p ∈ 1..pmaxq
    if ssp,q ≠ 0
      F ← MBlg(p, q, φlg0, Xs, Xcf, Ts, Ls, Bs, Fm, Tm, Bm, Lm)
      mean ← mean + |F| ·  $\frac{ss_{p,q}}{sum}$ 
      m2 ← m2 + (F)2 ·  $\frac{ss_{p,q}}{sum}$ 
  design ← mean + β · √(m2 - (mean)2)
  design

```

```

q_twist_MB_neg (Xs, Xcf, Ts, Ls, Bs, Fm, Tm, Bm, Lm) :=
  qmax ← 0
  F ← 0
  for q ∈ 1..dmaxlg(Lm)
    p ← pmaxq
    Ftemp ← |MBlg(p, q, φlg2, Xs, Xcf, Ts, Ls, Bs, Fm, Tm, Bm, Lm)|
    if Ftemp > F
      qmax ← q
      F ← Ftemp
  qmax

```

```

design_twist_MB_neg (Xs, Xcf, Ts, Ls, Bs, Fm, Tm, Bm, Lm) :=
  mean ← 0
  m2 ← 0
  design ← 0
  q ← q_twist_MB_neg (Xs, Xcf, Ts, Ls, Bs, Fm, Tm, Bm, Lm)
  sum ← ∑p=1pmaxq ssp,q
  for p ∈ 1..pmaxq
    if ssp,q ≠ 0
      F ← MBlg(p, q, φlg2, Xs, Xcf, Ts, Ls, Bs, Fm, Tm, Bm, Lm)
      mean ← mean + |F| ·  $\frac{ss_{p,q}}{sum}$ 
      m2 ← m2 + (F)2 ·  $\frac{ss_{p,q}}{sum}$ 
  design ← -[mean + β · √(m2 - (mean)2)]
  design

```

$$\text{dmax_tr}(Y_s) := \left\{ \begin{array}{l} \text{dmax_tr} \leftarrow 0 \\ \text{for } n \in 1..D \\ \quad \text{dmax_tr} \leftarrow n \text{ if } \lambda_n < 2 \cdot Y_s \\ \text{dmax_tr} \leftarrow \text{dmax_tr} + 3 \end{array} \right.$$

$$\text{q_tr_sag_FB}(Y_s, T_s, L_s, B_s, F_m, T_m, B_m, L_m) := \left\{ \begin{array}{l} q_{\max} \leftarrow 0 \\ F \leftarrow 0 \\ \text{for } q \in 1.. \text{dmax_tr}(Y_s) \\ \quad \left\{ \begin{array}{l} p \leftarrow p_{\max_q} \\ F_{\text{temp}} \leftarrow \left| \text{FB}_{\text{tr}}(p, q, \phi_{\text{tr}_1}, Y_s, T_s, L_s, B_s, F_m, T_m, B_m, L_m) \right| \\ \text{if } F_{\text{temp}} > F \\ \quad \left\{ \begin{array}{l} q_{\max} \leftarrow q \\ F \leftarrow F_{\text{temp}} \end{array} \right. \end{array} \right. \\ q_{\max} \end{array} \right.$$

$$\text{design_tr_sag_FB}_s(Y_s, T_s, L_s, B_s, F_m, T_m, B_m, L_m) := \left\{ \begin{array}{l} \text{mean} \leftarrow 0 \\ m2 \leftarrow 0 \\ \text{design} \leftarrow 0 \\ q \leftarrow \text{q_tr_sag_FB}(Y_s, T_s, L_s, B_s, F_m, T_m, B_m, L_m) \\ \text{sum} \leftarrow \sum_{p=1}^{p_{\max_q}} \text{ss}_{p,q} \\ \text{for } p \in 1.. p_{\max_q} \\ \quad \text{if } \text{ss}_{p,q} \neq 0 \\ \quad \quad \left\{ \begin{array}{l} F \leftarrow \text{FB}_{\text{tr}}(p, q, \phi_{\text{tr}_1}, Y_s, T_s, L_s, B_s, F_m, T_m, B_m, L_m) \\ \text{mean} \leftarrow \text{mean} + |F| \cdot \frac{\text{ss}_{p,q}}{\text{sum}} \\ m2 \leftarrow m2 + (F)^2 \cdot \frac{\text{ss}_{p,q}}{\text{sum}} \end{array} \right. \\ \text{design} \leftarrow \left[\text{mean} + \beta \sqrt{m2 - (\text{mean})^2} \right] \\ \text{design} \end{array} \right.$$

```

q_tr_hog_FB (Y_s, T_s, L_s, B_s, F_m, T_m, B_m, L_m) :=
  q_max ← 0
  F ← 0
  for q ∈ 1..dmax_tr(Y_s)
    p ← pmax_q
    Ftemp ← |FB_tr(p, q, φ_tr0, Y_s, T_s, L_s, B_s, F_m, T_m, B_m, L_m)|
    if Ftemp > F
      q_max ← q
      F ← Ftemp
  q_max

```

```

design_tr_hog_FB_s(Y_s, T_s, L_s, B_s, F_m, T_m, B_m, L_m) :=
  mean ← 0
  m2 ← 0
  design ← 0
  q ← q_tr_hog_FB(Y_s, T_s, L_s, B_s, F_m, T_m, B_m, L_m)
  sum ← ∑_{p=1}^{pmax_q} ss_{p,q}
  for p ∈ 1..pmax_q
    if ss_{p,q} ≠ 0
      F ← FB_tr(p, q, φ_tr0, Y_s, T_s, L_s, B_s, F_m, T_m, B_m, L_m)
      mean ← mean + |F| · \frac{ss_{p,q}}{sum}
      m2 ← m2 + (F)^2 · \frac{ss_{p,q}}{sum}
  design ← -[mean + β · √{m2 - (mean)^2}]
  design

```

Explained in Section 4.1.1.7

file_root := "C:\Documents and Settings\jlrhoads\My Documents\rhoads thesis data"

file_base(L_m) := num2str($\frac{L_m}{m}$) file_ext := ".prn" cc(a, b) := concat(a, b)

fullname_lg(L_m) := file_root cc [[file_base(L_m) cc ("_lg" cc file_ext)]]

fullname_tr(L_m) := file_root cc [[file_base(L_m) cc ("_tr" cc file_ext)]]

for j ∈ 0..12

$$L_m \leftarrow (60 + 20 \cdot j) \cdot m$$

$$B_m \leftarrow \frac{L_m}{14}$$

$$T_m \leftarrow \frac{B_m}{2}$$

$$D_m \leftarrow 2.4 T_m$$

$$F_m \leftarrow D_m - T_m$$

$$\text{data}_{lg} \leftarrow (0 \ 0 \ 0 \ 0 \ 0 \ 0 \ 0 \ 0)$$

$$\text{data}_{tr} \leftarrow (0 \ 0 \ 0 \ 0 \ 0 \ 0)$$

WRITEPRN(fullname_lg(L_m), data_lg)

WRITEPRN(fullname_tr(L_m), data_tr)

for n ∈ 0..5

$$L_s \leftarrow L_m \cdot (0.25 + n \cdot 0.05)$$

$$T_s \leftarrow \sqrt{\frac{L_m \cdot B_m \cdot T_m}{L_s}} \cdot 0.04$$

$$B_s \leftarrow T_s$$

for i ∈ 0..5

$$X_{smax} \leftarrow \left(\frac{L_m}{2} - \frac{L_s}{2} \right)$$

$$X_{inc} \leftarrow \frac{X_{smax}}{5}$$

$$X_s \leftarrow X_{inc} \cdot i$$

$$X_{cf} \leftarrow \frac{B_m \cdot L_m \cdot 0 \cdot m + 2 B_s \cdot L_s \cdot X_s}{B_m \cdot L_m + 2 B_s \cdot L_s}$$

$$\text{data}_{lg0,0} \leftarrow \frac{L_m}{m}$$

$$\text{data}_{lg0,1} \leftarrow \frac{L_s}{m}$$

$$\text{data}_{lg0,2} \leftarrow \frac{B_s}{m}$$

$$\text{data}_{lg0,3} \leftarrow \frac{X_s}{m}$$

$$\text{data}_{lg0,4} \leftarrow \frac{\text{design_lg_sag_FB}_s(X_s, X_{cf}, T_s, L_s, B_s, F_m, T_m, B_m, L_m)}{N}$$

$$\text{data}_{lg0,5} \leftarrow \frac{\text{design_lg_hog_FB}_s(X_s, X_{cf}, T_s, L_s, B_s, F_m, T_m, B_m, L_m)}{N}$$

$$\text{data}_{lg0,6} \leftarrow \frac{\text{design_twist_MB_pos}(X_s, X_{cf}, T_s, L_s, B_s, F_m, T_m, B_m, L_m)}{N \cdot m}$$

$$\text{data}_{lg0,7} \leftarrow \frac{\text{design_twist_MB_neg}(X_s, X_{cf}, T_s, L_s, B_s, F_m, T_m, B_m, L_m)}{N \cdot m}$$

APPENDPRN(fullname_lg(L_m), data_lg)

for i ∈ 0..5

$$Y_s \leftarrow B_m \cdot (1 + i \cdot 0.1)$$

$$\text{data}_{tr0,0} \leftarrow \frac{L_m}{m}$$

$$\text{data}_{tr0,1} \leftarrow \frac{L_s}{m}$$

$$\text{data}_{tr0,2} \leftarrow \frac{B_s}{m}$$

$$\text{data}_{tr0,3} \leftarrow \frac{Y_s}{m}$$

$$\text{data}_{tr0,4} \leftarrow \frac{\text{design_tr_sag_FB}_s(Y_s, T_s, L_s, B_s, F_m, T_m, B_m, L_m)}{N}$$

$$\text{data}_{tr0,5} \leftarrow \frac{\text{design_tr_hog_FB}_s(Y_s, T_s, L_s, B_s, F_m, T_m, B_m, L_m)}{N}$$

APPENDPRN(fullname_tr(L_m), data_tr)

"done"

Page Intentionally Left Blank

Appendix B. MathCAD Analytical Results Tables

Lm (m)	Ls (m)	Bs (m)	Xs (m)	F_lg_sag (N)	F_lg_hog (N)	M_lg_pos (Nm)	M_lg_neg (Nm)
60	15	1.212	0	-2.63E+05	3.22E+05	8.52E+05	-8.52E+05
60	15	1.212	-4.5	-2.54E+05	2.62E+05	8.48E+05	-7.95E+05
60	15	1.212	-9	-2.28E+05	2.32E+05	8.29E+05	-7.84E+05
60	15	1.212	-13.5	-1.88E+05	1.90E+05	8.05E+05	-7.77E+05
60	15	1.212	-18	-1.48E+05	1.48E+05	7.95E+05	-8.25E+05
60	15	1.212	-22.5	-1.21E+05	1.35E+05	8.02E+05	-8.85E+05
60	18	1.107	0	-2.55E+05	3.31E+05	1.23E+06	-1.23E+06
60	18	1.107	-4.2	-2.47E+05	2.59E+05	1.24E+06	-1.04E+06
60	18	1.107	-8.4	-2.23E+05	2.29E+05	1.22E+06	-1.02E+06
60	18	1.107	-12.6	-1.86E+05	1.89E+05	1.18E+06	-1.01E+06
60	18	1.107	-16.8	-1.45E+05	1.46E+05	1.16E+06	-1.21E+06
60	18	1.107	-21	-1.14E+05	1.21E+05	1.14E+06	-1.32E+06
60	21	1.024	0	-3.09E+05	3.33E+05	1.64E+06	-1.64E+06
60	21	1.024	-3.9	-2.93E+05	3.09E+05	1.65E+06	-1.59E+06
60	21	1.024	-7.8	-2.09E+05	2.19E+05	1.64E+06	-1.19E+06
60	21	1.024	-11.7	-1.76E+05	1.84E+05	1.60E+06	-1.17E+06
60	21	1.024	-15.6	-1.37E+05	1.29E+05	1.56E+06	-1.61E+06
60	21	1.024	-19.5	-1.07E+05	1.08E+05	1.53E+06	-1.79E+06
60	24	0.9583	0	-2.99E+05	3.27E+05	2.04E+06	-2.04E+06
60	24	0.9583	-3.6	-2.84E+05	3.06E+05	2.06E+06	-1.99E+06
60	24	0.9583	-7.2	-2.43E+05	2.53E+05	2.06E+06	-1.92E+06
60	24	0.9583	-10.8	-1.59E+05	1.88E+05	2.02E+06	-1.85E+06
60	24	0.9583	-14.4	-1.28E+05	1.29E+05	1.96E+06	-2.00E+06
60	24	0.9583	-18	-9.53E+04	9.63E+04	1.92E+06	-2.24E+06
60	27	0.9035	0	-2.84E+05	3.16E+05	2.42E+06	-2.42E+06
60	27	0.9035	-3.3	-2.71E+05	2.97E+05	2.45E+06	-2.36E+06
60	27	0.9035	-6.6	-2.34E+05	2.50E+05	2.44E+06	-2.28E+06
60	27	0.9035	-9.9	-1.82E+05	1.10E+05	2.40E+06	-2.20E+06
60	27	0.9035	-13.2	-1.26E+05	1.30E+05	2.34E+06	-2.36E+06
60	27	0.9035	-16.5	-1.66E+04	8.86E+04	2.29E+06	-2.65E+06
60	30	0.8571	0	-8.61E+04	2.99E+05	2.75E+06	-2.75E+06
60	30	0.8571	-3	-7.52E+04	2.83E+05	2.78E+06	-2.68E+06
60	30	0.8571	-6	-4.98E+04	2.42E+05	2.77E+06	-2.60E+06
60	30	0.8571	-9	-2.70E+04	1.87E+05	2.73E+06	-2.50E+06
60	30	0.8571	-12	-1.96E+04	1.31E+05	2.66E+06	-2.69E+06
60	30	0.8571	-15	-2.83E+04	8.55E+04	2.59E+06	-3.00E+06

Lm (m)	Ls (m)	Bs (m)	Ys (m)	F_tr_sag (N)	F_tr_hog (N)
60	15	1.212	4.286	1.73E+05	-1.69E+05
60	15	1.212	4.714	1.97E+05	-1.90E+05
60	15	1.212	5.143	2.19E+05	-2.09E+05
60	15	1.212	5.571	2.38E+05	-2.24E+05
60	15	1.212	6	2.52E+05	-2.37E+05
60	15	1.212	6.429	2.62E+05	-2.45E+05
60	18	1.107	4.286	1.87E+05	-1.81E+05
60	18	1.107	4.714	2.14E+05	-2.04E+05
60	18	1.107	5.143	2.38E+05	-2.24E+05
60	18	1.107	5.571	2.58E+05	-2.39E+05
60	18	1.107	6	2.74E+05	-2.48E+05
60	18	1.107	6.429	2.84E+05	-2.49E+05
60	21	1.024	4.286	2.00E+05	-1.92E+05
60	21	1.024	4.714	2.29E+05	-2.16E+05
60	21	1.024	5.143	2.54E+05	-2.36E+05
60	21	1.024	5.571	2.76E+05	-2.47E+05
60	21	1.024	6	2.93E+05	-2.49E+05
60	21	1.024	6.429	3.04E+05	-2.48E+05
60	24	0.9583	4.286	2.12E+05	-2.02E+05
60	24	0.9583	4.714	2.42E+05	-2.27E+05
60	24	0.9583	5.143	2.69E+05	-2.44E+05
60	24	0.9583	5.571	2.92E+05	-2.49E+05
60	24	0.9583	6	3.10E+05	-2.48E+05
60	24	0.9583	6.429	3.22E+05	-2.47E+05
60	27	0.9035	4.286	2.22E+05	-2.11E+05
60	27	0.9035	4.714	2.55E+05	-2.35E+05
60	27	0.9035	5.143	2.83E+05	-2.47E+05
60	27	0.9035	5.571	3.07E+05	-2.48E+05
60	27	0.9035	6	3.26E+05	-2.47E+05
60	27	0.9035	6.429	3.38E+05	-2.46E+05
60	30	0.8571	4.286	2.33E+05	-2.20E+05
60	30	0.8571	4.714	2.66E+05	-2.41E+05
60	30	0.8571	5.143	2.96E+05	-2.48E+05
60	30	0.8571	5.571	3.21E+05	-2.47E+05
60	30	0.8571	6	3.41E+05	-2.46E+05
60	30	0.8571	6.429	3.54E+05	-2.45E+05

Lm (m)	Ls (m)	Bs (m)	Xs (m)	F_lg_sag (N)	F_lg_hog (N)	M_lg_pos (Nm)	M_lg_neg (Nm)
80	20	1.616	0	-6.02E+05	6.17E+05	2.49E+06	-2.49E+06
80	20	1.616	-6	-5.72E+05	5.83E+05	2.24E+06	-2.41E+06
80	20	1.616	-12	-4.93E+05	4.97E+05	2.25E+06	-2.22E+06
80	20	1.616	-18	-3.96E+05	3.97E+05	2.26E+06	-1.82E+06
80	20	1.616	-24	-3.23E+05	3.23E+05	2.17E+06	-2.29E+06
80	20	1.616	-30	-2.97E+05	2.97E+05	2.32E+06	-2.47E+06
80	24	1.475	0	-5.97E+05	6.17E+05	3.47E+06	-3.47E+06
80	24	1.475	-5.6	-5.68E+05	5.85E+05	3.31E+06	-3.36E+06
80	24	1.475	-11.2	-4.93E+05	5.01E+05	3.33E+06	-3.08E+06
80	24	1.475	-16.8	-3.98E+05	4.00E+05	3.35E+06	-2.87E+06
80	24	1.475	-22.4	-3.17E+05	3.18E+05	2.93E+06	-3.38E+06
80	24	1.475	-28	-2.78E+05	2.78E+05	3.13E+06	-3.70E+06
80	28	1.366	0	-5.75E+05	5.98E+05	4.39E+06	-4.39E+06
80	28	1.366	-5.2	-6.28E+05	5.69E+05	4.48E+06	-4.25E+06
80	28	1.366	-10.4	-4.78E+05	4.90E+05	4.53E+06	-3.89E+06
80	28	1.366	-15.6	-3.87E+05	3.92E+05	4.56E+06	-3.57E+06
80	28	1.366	-20.8	-3.02E+05	3.04E+05	4.55E+06	-4.54E+06
80	28	1.366	-26	-2.52E+05	2.17E+05	3.78E+06	-5.04E+06
80	32	1.278	0	-6.51E+05	6.88E+05	5.61E+06	-5.61E+06
80	32	1.278	-4.8	-6.16E+05	6.45E+05	5.68E+06	-4.96E+06
80	32	1.278	-9.6	-4.50E+05	4.66E+05	5.76E+06	-4.52E+06
80	32	1.278	-14.4	-3.64E+05	3.94E+05	5.80E+06	-5.03E+06
80	32	1.278	-19.2	-2.80E+05	2.67E+05	5.81E+06	-5.71E+06
80	32	1.278	-24	-2.20E+05	1.95E+05	5.76E+06	-6.39E+06
80	36	1.205	0	-6.23E+05	6.65E+05	6.74E+06	-6.74E+06
80	36	1.205	-4.4	-5.92E+05	6.27E+05	6.83E+06	-5.38E+06
80	36	1.205	-8.8	-5.07E+05	5.28E+05	6.93E+06	-6.49E+06
80	36	1.205	-13.2	-1.25E+05	3.97E+05	7.00E+06	-6.46E+06
80	36	1.205	-17.6	-6.85E+04	2.70E+05	7.02E+06	-6.80E+06
80	36	1.205	-22	-4.50E+04	1.80E+05	6.99E+06	-7.63E+06
80	40	1.143	0	-5.84E+05	6.31E+05	7.73E+06	-7.73E+06
80	40	1.143	-4	-5.58E+05	5.99E+05	7.85E+06	-7.57E+06
80	40	1.143	-8	-4.84E+05	4.90E+05	7.96E+06	-7.44E+06
80	40	1.143	-12	-1.28E+05	3.95E+05	8.06E+06	-7.38E+06
80	40	1.143	-16	-8.05E+04	2.74E+05	8.11E+06	-7.75E+06
80	40	1.143	-20	-2.42E+04	1.74E+05	8.10E+06	-8.65E+06

Lm (m)	Ls (m)	Bs (m)	Ys (m)	F_tr_sag (N)	F_tr_hog (N)
80	20	1.616	5.714	4.04E+05	-3.98E+05
80	20	1.616	6.286	4.32E+05	-4.21E+05
80	20	1.616	6.857	4.45E+05	-4.32E+05
80	20	1.616	7.429	4.66E+05	-4.29E+05
80	20	1.616	8	5.17E+05	-4.13E+05
80	20	1.616	8.571	5.65E+05	-3.83E+05
80	24	1.475	5.714	4.38E+05	-4.26E+05
80	24	1.475	6.286	4.69E+05	-4.52E+05
80	24	1.475	6.857	4.83E+05	-4.63E+05
80	24	1.475	7.429	5.04E+05	-4.60E+05
80	24	1.475	8	5.60E+05	-4.43E+05
80	24	1.475	8.571	6.12E+05	-4.12E+05
80	28	1.366	5.714	4.68E+05	-4.51E+05
80	28	1.366	6.286	5.02E+05	-4.79E+05
80	28	1.366	6.857	5.17E+05	-4.92E+05
80	28	1.366	7.429	5.39E+05	-4.88E+05
80	28	1.366	8	5.99E+05	-4.69E+05
80	28	1.366	8.571	6.54E+05	-4.36E+05
80	32	1.278	5.714	4.96E+05	-4.75E+05
80	32	1.278	6.286	5.32E+05	-5.04E+05
80	32	1.278	6.857	5.47E+05	-5.18E+05
80	32	1.278	7.429	5.71E+05	-5.14E+05
80	32	1.278	8	6.34E+05	-4.94E+05
80	32	1.278	8.571	6.93E+05	-4.58E+05
80	36	1.205	5.714	5.22E+05	-4.96E+05
80	36	1.205	6.286	5.59E+05	-5.28E+05
80	36	1.205	6.857	5.76E+05	-5.42E+05
80	36	1.205	7.429	6.00E+05	-5.38E+05
80	36	1.205	8	6.66E+05	-5.16E+05
80	36	1.205	8.571	7.28E+05	-4.79E+05
80	40	1.143	5.714	5.46E+05	-5.17E+05
80	40	1.143	6.286	5.85E+05	-5.49E+05
80	40	1.143	6.857	6.02E+05	-5.65E+05
80	40	1.143	7.429	6.27E+05	-5.61E+05
80	40	1.143	8	6.96E+05	-5.38E+05
80	40	1.143	8.571	7.61E+05	-4.98E+05

Lm (m)	Ls (m)	Bs (m)	Xs (m)	F_lg_sag (N)	F_lg_hog (N)	M_lg_pos (Nm)	M_lg_neg (Nm)
100	25	2.02	0	-1.14E+06	1.17E+06	5.59E+06	-5.59E+06
100	25	2.02	-7.5	-1.07E+06	1.09E+06	5.43E+06	-4.73E+06
100	25	2.02	-15	-8.95E+05	8.99E+05	4.82E+06	-4.85E+06
100	25	2.02	-22.5	-6.95E+05	6.95E+05	4.70E+06	-4.87E+06
100	25	2.02	-30	-5.74E+05	5.74E+05	4.63E+06	-5.05E+06
100	25	2.02	-37.5	-5.80E+05	5.80E+05	4.70E+06	-5.52E+06
100	30	1.844	0	-1.15E+06	1.18E+06	8.03E+06	-8.03E+06
100	30	1.844	-7	-1.09E+06	1.11E+06	7.83E+06	-7.80E+06
100	30	1.844	-14	-9.14E+05	9.22E+05	7.15E+06	-6.16E+06
100	30	1.844	-21	-7.10E+05	7.12E+05	7.47E+06	-6.23E+06
100	30	1.844	-28	-5.65E+05	5.66E+05	6.55E+06	-7.44E+06
100	30	1.844	-35	-5.34E+05	5.34E+05	6.76E+06	-8.24E+06
100	35	1.707	0	-1.12E+06	1.16E+06	1.05E+07	-1.05E+07
100	35	1.707	-6.5	-1.07E+06	1.09E+06	1.03E+07	-1.02E+07
100	35	1.707	-13	-9.06E+05	9.20E+05	9.77E+06	-9.51E+06
100	35	1.707	-19.5	-7.07E+05	7.11E+05	1.02E+07	-6.99E+06
100	35	1.707	-26	-5.45E+05	5.46E+05	8.47E+06	-1.01E+07
100	35	1.707	-32.5	-4.79E+05	4.79E+05	8.58E+06	-1.13E+07
100	40	1.597	0	-1.19E+06	1.11E+06	1.29E+07	-1.29E+07
100	40	1.597	-6	-1.02E+06	1.05E+06	1.26E+07	-1.25E+07
100	40	1.597	-12	-8.75E+05	8.95E+05	1.25E+07	-1.17E+07
100	40	1.597	-18	-6.85E+05	6.94E+05	1.31E+07	-1.25E+07
100	40	1.597	-24	-5.15E+05	5.18E+05	1.35E+07	-1.27E+07
100	40	1.597	-30	-4.18E+05	3.21E+05	1.01E+07	-1.43E+07
100	45	1.506	0	-1.15E+06	1.05E+06	1.49E+07	-1.49E+07
100	45	1.506	-5.5	-1.09E+06	1.13E+06	1.46E+07	-1.45E+07
100	45	1.506	-11	-8.20E+05	9.51E+05	1.52E+07	-1.35E+07
100	45	1.506	-16.5	-6.49E+05	7.22E+05	1.59E+07	-1.50E+07
100	45	1.506	-22	-4.77E+05	4.75E+05	1.65E+07	-1.52E+07
100	45	1.506	-27.5	-3.76E+04	3.03E+05	1.68E+07	-1.72E+07
100	50	1.429	0	-1.08E+06	9.57E+05	1.63E+07	-1.63E+07
100	50	1.429	-5	-1.03E+06	1.08E+06	1.70E+07	-1.59E+07
100	50	1.429	-10	-2.19E+05	9.27E+05	1.76E+07	-1.47E+07
100	50	1.429	-15	-1.30E+05	6.79E+05	1.84E+07	-1.72E+07
100	50	1.429	-20	-7.48E+04	4.88E+05	1.91E+07	-1.73E+07
100	50	1.429	-25	-7.57E+04	3.02E+05	1.97E+07	-1.96E+07

Lm (m)	Ls (m)	Bs (m)	Ys (m)	F_tr_sag (N)	F_tr_hog (N)
100	25	2.02	7.143	6.58E+05	-6.41E+05
100	25	2.02	7.857	7.60E+05	-7.59E+05
100	25	2.02	8.571	8.54E+05	-8.51E+05
100	25	2.02	9.286	9.38E+05	-9.31E+05
100	25	2.02	10	1.01E+06	-9.99E+05
100	25	2.02	10.71	1.06E+06	-1.05E+06
100	30	1.844	7.143	7.13E+05	-6.96E+05
100	30	1.844	7.857	8.23E+05	-6.67E+05
100	30	1.844	8.571	9.25E+05	-9.20E+05
100	30	1.844	9.286	1.02E+06	-1.01E+06
100	30	1.844	10	1.09E+06	-1.08E+06
100	30	1.844	10.71	1.15E+06	-1.13E+06
100	35	1.707	7.143	7.62E+05	-7.44E+05
100	35	1.707	7.857	8.80E+05	-7.14E+05
100	35	1.707	8.571	9.89E+05	-9.81E+05
100	35	1.707	9.286	1.09E+06	-1.07E+06
100	35	1.707	10	1.17E+06	-1.14E+06
100	35	1.707	10.71	1.23E+06	-1.19E+06
100	40	1.597	7.143	8.07E+05	-7.81E+05
100	40	1.597	7.857	9.32E+05	-7.53E+05
100	40	1.597	8.571	1.05E+06	-6.79E+05
100	40	1.597	9.286	1.15E+06	-1.12E+06
100	40	1.597	10	1.24E+06	-1.19E+06
100	40	1.597	10.71	1.30E+06	-1.24E+06
100	45	1.506	7.143	8.48E+05	-8.14E+05
100	45	1.506	7.857	9.80E+05	-7.86E+05
100	45	1.506	8.571	1.10E+06	-7.12E+05
100	45	1.506	9.286	1.21E+06	-1.17E+06
100	45	1.506	10	1.30E+06	-1.24E+06
100	45	1.506	10.71	1.37E+06	-1.29E+06
100	50	1.429	7.143	8.87E+05	-8.46E+05
100	50	1.429	7.857	1.02E+06	-8.17E+05
100	50	1.429	8.571	1.15E+06	-7.42E+05
100	50	1.429	9.286	1.26E+06	-1.21E+06
100	50	1.429	10	1.36E+06	-1.28E+06
100	50	1.429	10.71	1.43E+06	-1.34E+06

Lm (m)	Ls (m)	Bs (m)	Xs (m)	F_lg_sag (N)	F_lg_hog (N)	M_lg_pos (Nm)	M_lg_neg (Nm)
120	30	2.424	0	-1.56E+06	1.94E+06	1.03E+07	-1.03E+07
120	30	2.424	-9	-1.50E+06	1.51E+06	1.01E+07	-9.99E+06
120	30	2.424	-18	-1.45E+06	1.35E+06	9.79E+06	-9.30E+06
120	30	2.424	-27	-1.11E+06	1.11E+06	9.43E+06	-8.17E+06
120	30	2.424	-36	-8.82E+05	8.83E+05	9.24E+06	-9.55E+06
120	30	2.424	-45	-9.39E+05	9.38E+05	9.84E+06	-1.06E+07
120	36	2.213	0	-1.95E+06	1.98E+06	1.50E+07	-1.50E+07
120	36	2.213	-8.4	-1.83E+06	1.85E+06	1.49E+07	-1.38E+07
120	36	2.213	-16.8	-1.51E+06	1.33E+06	1.44E+07	-1.28E+07
120	36	2.213	-25.2	-1.13E+06	1.10E+06	1.39E+07	-1.21E+07
120	36	2.213	-33.6	-8.75E+05	8.75E+05	1.35E+07	-1.41E+07
120	36	2.213	-42	-8.53E+05	8.53E+05	1.34E+07	-1.58E+07
120	42	2.049	0	-1.92E+06	1.97E+06	2.01E+07	-2.01E+07
120	42	2.049	-7.8	-1.81E+06	1.85E+06	2.00E+07	-1.72E+07
120	42	2.049	-15.6	-1.52E+06	1.53E+06	1.94E+07	-1.58E+07
120	42	2.049	-23.4	-1.15E+06	1.15E+06	1.87E+07	-1.48E+07
120	42	2.049	-31.2	-8.56E+05	8.57E+05	1.81E+07	-1.91E+07
120	42	2.049	-39	-7.59E+05	7.59E+05	1.79E+07	-2.16E+07
120	48	1.917	0	-1.86E+06	1.92E+06	2.53E+07	-2.53E+07
120	48	1.917	-7.2	-1.76E+06	1.81E+06	2.51E+07	-2.48E+07
120	48	1.917	-14.4	-1.49E+06	1.52E+06	2.45E+07	-2.40E+07
120	48	1.917	-21.6	-1.14E+06	1.15E+06	2.36E+07	-2.30E+07
120	48	1.917	-28.8	-8.28E+05	8.30E+05	2.28E+07	-2.60E+07
120	48	1.917	-36	-6.66E+05	6.67E+05	2.23E+07	-2.75E+07
120	54	1.807	0	-1.88E+06	1.83E+06	3.00E+07	-3.00E+07
120	54	1.807	-6.6	-1.78E+06	1.73E+06	2.99E+07	-2.95E+07
120	54	1.807	-13.2	-1.43E+06	1.47E+06	2.92E+07	-2.85E+07
120	54	1.807	-19.8	-1.11E+06	1.12E+06	2.82E+07	-2.73E+07
120	54	1.807	-26.4	-7.91E+05	7.97E+05	2.71E+07	-3.12E+07
120	54	1.807	-33	-9.56E+04	5.82E+05	2.64E+07	-3.30E+07
120	60	1.714	0	-1.78E+06	1.70E+06	3.39E+07	-3.39E+07
120	60	1.714	-6	-1.70E+06	1.62E+06	3.38E+07	-3.33E+07
120	60	1.714	-12	-1.34E+06	1.51E+06	3.31E+07	-3.22E+07
120	60	1.714	-18	-3.60E+05	1.16E+06	3.53E+07	-3.09E+07
120	60	1.714	-24	-2.12E+05	7.87E+05	3.79E+07	-3.58E+07
120	60	1.714	-30	-7.88E+04	4.68E+05	4.00E+07	-3.78E+07

Lm (m)	Ls (m)	Bs (m)	Ys (m)	F_tr_sag (N)	F_tr_hog (N)
120	30	2.424	8.571	1.18E+06	-1.18E+06
120	30	2.424	9.429	1.32E+06	-1.32E+06
120	30	2.424	10.29	1.44E+06	-1.43E+06
120	30	2.424	11.14	1.52E+06	-1.51E+06
120	30	2.424	12	1.56E+06	-1.55E+06
120	30	2.424	12.86	1.56E+06	-1.55E+06
120	36	2.213	8.571	1.28E+06	-1.28E+06
120	36	2.213	9.429	1.43E+06	-1.43E+06
120	36	2.213	10.29	1.56E+06	-1.55E+06
120	36	2.213	11.14	1.64E+06	-1.63E+06
120	36	2.213	12	1.69E+06	-1.68E+06
120	36	2.213	12.86	1.69E+06	-1.68E+06
120	42	2.049	8.571	1.37E+06	-1.37E+06
120	42	2.049	9.429	1.53E+06	-1.53E+06
120	42	2.049	10.29	1.67E+06	-1.65E+06
120	42	2.049	11.14	1.76E+06	-1.74E+06
120	42	2.049	12	1.81E+06	-1.79E+06
120	42	2.049	12.86	1.81E+06	-1.79E+06
120	48	1.917	8.571	1.45E+06	-1.45E+06
120	48	1.917	9.429	1.62E+06	-1.61E+06
120	48	1.917	10.29	1.76E+06	-1.75E+06
120	48	1.917	11.14	1.86E+06	-1.84E+06
120	48	1.917	12	1.91E+06	-1.89E+06
120	48	1.917	12.86	1.91E+06	-1.90E+06
120	54	1.807	8.571	1.53E+06	-1.52E+06
120	54	1.807	9.429	1.71E+06	-1.69E+06
120	54	1.807	10.29	1.85E+06	-1.83E+06
120	54	1.807	11.14	1.96E+06	-1.92E+06
120	54	1.807	12	2.01E+06	-1.97E+06
120	54	1.807	12.86	2.01E+06	-1.97E+06
120	60	1.714	8.571	1.59E+06	-1.58E+06
120	60	1.714	9.429	1.79E+06	-1.77E+06
120	60	1.714	10.29	1.94E+06	-1.91E+06
120	60	1.714	11.14	2.05E+06	-1.99E+06
120	60	1.714	12	2.10E+06	-2.03E+06
120	60	1.714	12.86	2.10E+06	-2.03E+06

Lm (m)	Ls (m)	Bs (m)	Xs (m)	F_lg_sag (N)	F_lg_hog (N)	M_lg_pos (Nm)	M_lg_neg (Nm)
140	35	2.828	0	-2.66E+06	2.68E+06	1.87E+07	-1.87E+07
140	35	2.828	-10.5	-2.51E+06	2.52E+06	1.66E+07	-1.59E+07
140	35	2.828	-21	-2.13E+06	2.14E+06	1.68E+07	-1.60E+07
140	35	2.828	-31.5	-1.70E+06	1.70E+06	1.70E+07	-1.60E+07
140	35	2.828	-42	-1.39E+06	1.39E+06	1.54E+07	-1.79E+07
140	35	2.828	-52.5	-1.30E+06	1.32E+06	1.63E+07	-1.89E+07
140	42	2.582	0	-2.65E+06	2.68E+06	2.68E+07	-2.68E+07
140	42	2.582	-9.8	-2.52E+06	2.54E+06	2.46E+07	-2.60E+07
140	42	2.582	-19.6	-2.15E+06	2.16E+06	2.49E+07	-2.06E+07
140	42	2.582	-29.4	-1.71E+06	1.72E+06	2.52E+07	-2.07E+07
140	42	2.582	-39.2	-1.37E+06	1.37E+06	2.16E+07	-2.66E+07
140	42	2.582	-49	-1.22E+06	1.18E+06	2.26E+07	-2.72E+07
140	49	2.39	0	-3.00E+06	2.61E+06	3.51E+07	-3.51E+07
140	49	2.39	-9.1	-2.82E+06	2.48E+06	3.35E+07	-3.41E+07
140	49	2.39	-18.2	-2.11E+06	2.12E+06	3.39E+07	-3.14E+07
140	49	2.39	-27.3	-1.68E+06	1.69E+06	3.44E+07	-2.35E+07
140	49	2.39	-36.4	-1.31E+06	1.31E+06	3.46E+07	-3.61E+07
140	49	2.39	-45.5	-1.10E+06	1.05E+06	2.83E+07	-3.71E+07
140	56	2.236	0	-2.93E+06	3.00E+06	4.28E+07	-4.28E+07
140	56	2.236	-8.4	-2.76E+06	2.35E+06	4.27E+07	-4.15E+07
140	56	2.236	-16.8	-2.32E+06	2.03E+06	4.33E+07	-3.83E+07
140	56	2.236	-25.2	-1.74E+06	1.61E+06	4.39E+07	-4.27E+07
140	56	2.236	-33.6	-1.21E+06	1.21E+06	4.43E+07	-4.59E+07
140	56	2.236	-42	-9.65E+05	9.32E+05	4.43E+07	-4.73E+07
140	63	2.108	0	-2.85E+06	2.88E+06	4.89E+07	-4.89E+07
140	63	2.108	-7.7	-2.65E+06	2.73E+06	5.16E+07	-4.75E+07
140	63	2.108	-15.4	-2.26E+06	2.30E+06	5.23E+07	-4.38E+07
140	63	2.108	-23.1	-1.73E+06	1.72E+06	5.31E+07	-5.13E+07
140	63	2.108	-30.8	-1.20E+06	1.20E+06	5.37E+07	-5.51E+07
140	63	2.108	-38.5	-8.32E+05	8.35E+05	5.39E+07	-6.06E+07
140	70	2	0	-2.71E+06	2.72E+06	5.88E+07	-5.88E+07
140	70	2	-7	-2.59E+06	2.58E+06	5.94E+07	-5.14E+07
140	70	2	-14	-2.16E+06	2.22E+06	6.03E+07	-5.85E+07
140	70	2	-21	-1.68E+06	1.71E+06	6.13E+07	-5.90E+07
140	70	2	-28	-1.28E+05	1.19E+06	6.21E+07	-6.33E+07
140	70	2	-35	-1.73E+05	7.69E+05	6.26E+07	-6.97E+07

Lm (m)	Ls (m)	Bs (m)	Ys (m)	F_tr_sag (N)	F_tr_hog (N)
140	35	2.828	10	1.83E+06	-1.83E+06
140	35	2.828	11	1.97E+06	-1.97E+06
140	35	2.828	12	2.04E+06	-2.04E+06
140	35	2.828	13	2.11E+06	-2.04E+06
140	35	2.828	14	2.31E+06	-1.97E+06
140	35	2.828	15	2.49E+06	-1.83E+06
140	42	2.582	10	1.99E+06	-1.98E+06
140	42	2.582	11	2.14E+06	-2.13E+06
140	42	2.582	12	2.21E+06	-2.21E+06
140	42	2.582	13	2.29E+06	-2.21E+06
140	42	2.582	14	2.50E+06	-2.13E+06
140	42	2.582	15	2.69E+06	-1.98E+06
140	49	2.39	10	2.12E+06	-2.12E+06
140	49	2.39	11	2.29E+06	-2.28E+06
140	49	2.39	12	2.37E+06	-2.36E+06
140	49	2.39	13	2.45E+06	-2.36E+06
140	49	2.39	14	2.68E+06	-2.28E+06
140	49	2.39	15	2.88E+06	-2.12E+06
140	56	2.236	10	2.25E+06	-2.24E+06
140	56	2.236	11	2.42E+06	-2.41E+06
140	56	2.236	12	2.51E+06	-2.50E+06
140	56	2.236	13	2.59E+06	-2.49E+06
140	56	2.236	14	2.84E+06	-2.41E+06
140	56	2.236	15	3.05E+06	-2.24E+06
140	63	2.108	10	2.37E+06	-2.36E+06
140	63	2.108	11	2.55E+06	-2.53E+06
140	63	2.108	12	2.64E+06	-2.62E+06
140	63	2.108	13	2.72E+06	-2.62E+06
140	63	2.108	14	2.98E+06	-2.53E+06
140	63	2.108	15	3.21E+06	-2.35E+06
140	70	2	10	2.48E+06	-2.46E+06
140	70	2	11	2.67E+06	-2.64E+06
140	70	2	12	2.76E+06	-2.74E+06
140	70	2	13	2.85E+06	-2.74E+06
140	70	2	14	3.12E+06	-2.64E+06
140	70	2	15	3.35E+06	-2.46E+06

Lm (m)	Ls (m)	Bs (m)	Xs (m)	F_lg_sag (N)	F_lg_hog (N)	M_lg_pos (Nm)	M_lg_neg (Nm)
160	40	3.232	0	-4.08E+06	4.10E+06	2.93E+07	-2.93E+07
160	40	3.232	-12	-3.81E+06	3.82E+06	2.89E+07	-2.82E+07
160	40	3.232	-24	-3.12E+06	2.83E+06	2.77E+07	-2.49E+07
160	40	3.232	-36	-2.39E+06	2.34E+06	2.65E+07	-2.46E+07
160	40	3.232	-48	-1.97E+06	1.97E+06	2.57E+07	-2.88E+07
160	40	3.232	-60	-2.03E+06	2.03E+06	2.75E+07	-3.12E+07
160	48	2.951	0	-4.13E+06	4.17E+06	4.30E+07	-4.30E+07
160	48	2.951	-11.2	-3.87E+06	3.90E+06	4.24E+07	-3.92E+07
160	48	2.951	-22.4	-3.22E+06	3.23E+06	4.08E+07	-3.62E+07
160	48	2.951	-33.6	-2.46E+06	2.46E+06	3.89E+07	-3.01E+07
160	48	2.951	-44.8	-1.94E+06	1.94E+06	3.77E+07	-4.26E+07
160	48	2.951	-56	-1.86E+06	1.86E+06	3.76E+07	-4.67E+07
160	56	2.732	0	-4.06E+06	4.12E+06	5.76E+07	-5.76E+07
160	56	2.732	-10.4	-3.83E+06	3.87E+06	5.70E+07	-4.94E+07
160	56	2.732	-20.8	-3.22E+06	3.24E+06	5.49E+07	-4.53E+07
160	56	2.732	-31.2	-2.47E+06	2.47E+06	5.65E+07	-5.18E+07
160	56	2.732	-41.6	-1.88E+06	1.88E+06	5.05E+07	-5.79E+07
160	56	2.732	-52	-1.67E+06	1.67E+06	4.99E+07	-6.42E+07
160	64	2.556	0	-4.27E+06	3.98E+06	7.22E+07	-7.22E+07
160	64	2.556	-9.6	-4.03E+06	3.76E+06	7.15E+07	-7.10E+07
160	64	2.556	-19.2	-3.14E+06	3.17E+06	6.91E+07	-6.83E+07
160	64	2.556	-28.8	-2.43E+06	2.44E+06	7.25E+07	-6.50E+07
160	64	2.556	-38.4	-1.80E+06	1.80E+06	7.62E+07	-7.36E+07
160	64	2.556	-48	-1.46E+06	1.46E+06	6.18E+07	-8.22E+07
160	72	2.409	0	-4.11E+06	3.76E+06	8.55E+07	-8.55E+07
160	72	2.409	-8.8	-3.90E+06	3.56E+06	8.47E+07	-8.41E+07
160	72	2.409	-17.6	-3.32E+06	3.04E+06	8.21E+07	-8.09E+07
160	72	2.409	-26.4	-2.33E+06	2.35E+06	8.82E+07	-8.53E+07
160	72	2.409	-35.2	-1.69E+06	1.70E+06	9.29E+07	-8.85E+07
160	72	2.409	-44	-1.26E+06	1.10E+06	9.63E+07	-9.93E+07
160	80	2.286	0	-3.87E+06	3.47E+06	9.63E+07	-9.63E+07
160	80	2.286	-8	-3.69E+06	3.81E+06	9.55E+07	-9.47E+07
160	80	2.286	-16	-3.20E+06	3.27E+06	9.27E+07	-9.12E+07
160	80	2.286	-24	-2.48E+06	2.51E+06	1.02E+08	-9.84E+07
160	80	2.286	-32	-3.66E+05	1.72E+06	1.08E+08	-1.02E+08
160	80	2.286	-40	-1.16E+05	1.06E+06	1.13E+08	-1.14E+08

Lm (m)	Ls (m)	Bs (m)	Ys (m)	F_tr_sag (N)	F_tr_hog (N)
160	40	3.232	11.43	2.51E+06	-2.51E+06
160	40	3.232	12.57	2.58E+06	-2.56E+06
160	40	3.232	13.71	2.88E+06	-2.49E+06
160	40	3.232	14.86	3.15E+06	-3.15E+06
160	40	3.232	16	3.37E+06	-3.37E+06
160	40	3.232	17.14	3.54E+06	-3.53E+06
160	48	2.951	11.43	2.73E+06	-2.72E+06
160	48	2.951	12.57	2.79E+06	-2.78E+06
160	48	2.951	13.71	3.12E+06	-2.70E+06
160	48	2.951	14.86	3.42E+06	-2.50E+06
160	48	2.951	16	3.66E+06	-3.64E+06
160	48	2.951	17.14	3.83E+06	-3.82E+06
160	56	2.732	11.43	2.92E+06	-2.92E+06
160	56	2.732	12.57	2.98E+06	-2.98E+06
160	56	2.732	13.71	3.34E+06	-2.90E+06
160	56	2.732	14.86	3.65E+06	-2.68E+06
160	56	2.732	16	3.91E+06	-3.89E+06
160	56	2.732	17.14	4.10E+06	-4.08E+06
160	64	2.556	11.43	3.09E+06	-3.09E+06
160	64	2.556	12.57	3.16E+06	-3.16E+06
160	64	2.556	13.71	3.54E+06	-3.07E+06
160	64	2.556	14.86	3.87E+06	-2.84E+06
160	64	2.556	16	4.14E+06	-4.11E+06
160	64	2.556	17.14	4.34E+06	-4.30E+06
160	72	2.409	11.43	3.26E+06	-3.25E+06
160	72	2.409	12.57	3.32E+06	-3.32E+06
160	72	2.409	13.71	3.72E+06	-3.23E+06
160	72	2.409	14.86	4.07E+06	-2.98E+06
160	72	2.409	16	4.35E+06	-2.61E+06
160	72	2.409	17.14	4.56E+06	-4.50E+06
160	80	2.286	11.43	3.41E+06	-3.39E+06
160	80	2.286	12.57	3.47E+06	-3.46E+06
160	80	2.286	13.71	3.89E+06	-3.37E+06
160	80	2.286	14.86	4.25E+06	-3.12E+06
160	80	2.286	16	4.55E+06	-2.73E+06
160	80	2.286	17.14	4.77E+06	-4.69E+06

Lm (m)	Ls (m)	Bs (m)	Xs (m)	F_lg_sag (N)	F_lg_hog (N)	M_lg_pos (Nm)	M_lg_neg (Nm)
180	45	3.637	0	-5.14E+06	5.82E+06	4.65E+07	-4.65E+07
180	45	3.637	-13.5	-4.86E+06	4.87E+06	4.21E+07	-4.04E+07
180	45	3.637	-27	-4.15E+06	4.15E+06	4.24E+07	-3.93E+07
180	45	3.637	-40.5	-3.31E+06	3.31E+06	4.26E+07	-3.91E+07
180	45	3.637	-54	-2.70E+06	2.70E+06	3.83E+07	-4.29E+07
180	45	3.637	-67.5	-2.48E+06	2.71E+06	4.03E+07	-4.74E+07
180	54	3.32	0	-5.12E+06	5.96E+06	6.69E+07	-6.69E+07
180	54	3.32	-12.6	-5.51E+06	4.88E+06	6.24E+07	-6.49E+07
180	54	3.32	-25.2	-4.18E+06	4.19E+06	6.28E+07	-5.19E+07
180	54	3.32	-37.8	-3.34E+06	3.34E+06	6.31E+07	-5.13E+07
180	54	3.32	-50.4	-2.66E+06	2.66E+06	6.31E+07	-6.33E+07
180	54	3.32	-63	-2.33E+06	2.45E+06	5.60E+07	-7.09E+07
180	63	3.073	0	-5.88E+06	5.95E+06	8.81E+07	-8.81E+07
180	63	3.073	-11.7	-5.52E+06	4.75E+06	8.49E+07	-8.55E+07
180	63	3.073	-23.4	-4.57E+06	4.10E+06	8.55E+07	-7.92E+07
180	63	3.073	-35.1	-3.40E+06	3.27E+06	8.60E+07	-5.99E+07
180	63	3.073	-46.8	-2.54E+06	2.48E+06	8.62E+07	-8.60E+07
180	63	3.073	-58.5	-2.11E+06	2.18E+06	8.57E+07	-9.72E+07
180	72	2.875	0	-5.87E+06	5.81E+06	1.08E+08	-1.08E+08
180	72	2.875	-10.8	-5.40E+06	5.47E+06	1.08E+08	-1.05E+08
180	72	2.875	-21.6	-4.54E+06	3.90E+06	1.09E+08	-9.70E+07
180	72	2.875	-32.4	-3.42E+06	3.43E+06	1.10E+08	-1.08E+08
180	72	2.875	-43.2	-2.43E+06	2.43E+06	1.10E+08	-1.18E+08
180	72	2.875	-54	-1.92E+06	1.39E+06	1.10E+08	-1.24E+08
180	81	2.711	0	-5.70E+06	5.56E+06	1.30E+08	-1.30E+08
180	81	2.711	-9.9	-5.40E+06	5.26E+06	1.31E+08	-1.21E+08
180	81	2.711	-19.8	-4.40E+06	4.46E+06	1.32E+08	-1.12E+08
180	81	2.711	-29.7	-3.37E+06	3.39E+06	1.33E+08	-1.30E+08
180	81	2.711	-39.6	-2.36E+06	2.37E+06	1.33E+08	-1.42E+08
180	81	2.711	-49.5	-1.69E+06	1.69E+06	1.33E+08	-1.50E+08
180	90	2.571	0	-5.21E+06	5.22E+06	1.49E+08	-1.49E+08
180	90	2.571	-9	-5.16E+06	4.96E+06	1.50E+08	-1.31E+08
180	90	2.571	-18	-4.46E+06	4.26E+06	1.52E+08	-1.48E+08
180	90	2.571	-27	-3.25E+06	3.29E+06	1.53E+08	-1.49E+08
180	90	2.571	-36	-2.28E+06	2.30E+06	1.54E+08	-1.64E+08
180	90	2.571	-45	-3.27E+05	1.52E+06	1.54E+08	-1.73E+08

Lm (m)	Ls (m)	Bs (m)	Ys (m)	F_tr_sag (N)	F_tr_hog (N)
180	45	3.637	12.86	3.27E+06	-3.08E+06
180	45	3.637	14.14	3.69E+06	-3.69E+06
180	45	3.637	15.43	4.05E+06	-4.04E+06
180	45	3.637	16.71	4.32E+06	-4.31E+06
180	45	3.637	18	4.49E+06	-4.49E+06
180	45	3.637	19.29	4.48E+06	-4.56E+06
180	54	3.32	12.86	3.55E+06	-3.35E+06
180	54	3.32	14.14	4.00E+06	-4.00E+06
180	54	3.32	15.43	4.39E+06	-4.38E+06
180	54	3.32	16.71	4.68E+06	-4.67E+06
180	54	3.32	18	4.87E+06	-4.86E+06
180	54	3.32	19.29	4.85E+06	-4.93E+06
180	63	3.073	12.86	3.79E+06	-3.59E+06
180	63	3.073	14.14	4.28E+06	-3.41E+06
180	63	3.073	15.43	4.69E+06	-4.68E+06
180	63	3.073	16.71	5.00E+06	-4.99E+06
180	63	3.073	18	5.21E+06	-5.19E+06
180	63	3.073	19.29	5.19E+06	-5.27E+06
180	72	2.875	12.86	4.02E+06	-3.80E+06
180	72	2.875	14.14	4.53E+06	-3.61E+06
180	72	2.875	15.43	4.97E+06	-4.96E+06
180	72	2.875	16.71	5.30E+06	-5.28E+06
180	72	2.875	18	5.51E+06	-5.49E+06
180	72	2.875	19.29	5.49E+06	-5.58E+06
180	81	2.711	12.86	4.22E+06	-4.00E+06
180	81	2.711	14.14	4.77E+06	-3.80E+06
180	81	2.711	15.43	5.22E+06	-5.21E+06
180	81	2.711	16.71	5.57E+06	-5.55E+06
180	81	2.711	18	5.80E+06	-5.77E+06
180	81	2.711	19.29	5.78E+06	-5.86E+06
180	90	2.571	12.86	4.41E+06	-4.19E+06
180	90	2.571	14.14	4.98E+06	-3.98E+06
180	90	2.571	15.43	5.46E+06	-5.44E+06
180	90	2.571	16.71	5.83E+06	-5.79E+06
180	90	2.571	18	6.06E+06	-6.02E+06
180	90	2.571	19.29	6.04E+06	-6.10E+06

Lm (m)	Ls (m)	Bs (m)	Xs (m)	F_lg_sag (N)	F_lg_hog (N)	M_lg_pos (Nm)	M_lg_neg (Nm)
200	50	4.041	0	-7.41E+06	7.44E+06	6.70E+07	-6.70E+07
200	50	4.041	-15	-6.92E+06	6.94E+06	6.53E+07	-6.45E+07
200	50	4.041	-30	-5.69E+06	5.17E+06	6.29E+07	-5.69E+07
200	50	4.041	-45	-4.37E+06	4.27E+06	6.04E+07	-5.72E+07
200	50	4.041	-60	-3.60E+06	3.60E+06	5.69E+07	-6.64E+07
200	50	4.041	-75	-3.70E+06	3.70E+06	6.12E+07	-7.12E+07
200	60	3.689	0	-7.50E+06	7.54E+06	9.43E+07	-9.43E+07
200	60	3.689	-14	-7.04E+06	7.07E+06	9.59E+07	-9.09E+07
200	60	3.689	-28	-5.85E+06	5.86E+06	9.26E+07	-8.33E+07
200	60	3.689	-42	-4.49E+06	4.49E+06	9.44E+07	-7.26E+07
200	60	3.689	-56	-3.55E+06	3.55E+06	8.62E+07	-9.85E+07
200	60	3.689	-70	-3.40E+06	3.40E+06	8.59E+07	-1.07E+08
200	70	3.415	0	-7.97E+06	7.45E+06	1.31E+08	-1.31E+08
200	70	3.415	-13	-7.46E+06	7.01E+06	1.29E+08	-1.16E+08
200	70	3.415	-26	-5.85E+06	5.87E+06	1.25E+08	-1.06E+08
200	70	3.415	-39	-4.50E+06	4.51E+06	1.29E+08	-1.28E+08
200	70	3.415	-52	-3.44E+06	3.44E+06	1.16E+08	-1.34E+08
200	70	3.415	-65	-3.04E+06	3.04E+06	1.14E+08	-1.47E+08
200	80	3.194	0	-7.67E+06	7.18E+06	1.64E+08	-1.64E+08
200	80	3.194	-12	-7.37E+06	6.78E+06	1.62E+08	-1.38E+08
200	80	3.194	-24	-5.71E+06	5.74E+06	1.58E+08	-1.25E+08
200	80	3.194	-36	-4.41E+06	4.42E+06	1.66E+08	-1.63E+08
200	80	3.194	-48	-3.27E+06	3.28E+06	1.74E+08	-1.71E+08
200	80	3.194	-60	-2.66E+06	2.66E+06	1.42E+08	-1.89E+08
200	90	3.012	0	-7.47E+06	6.76E+06	1.95E+08	-1.95E+08
200	90	3.012	-11	-7.13E+06	7.23E+06	1.93E+08	-1.92E+08
200	90	3.012	-22	-6.05E+06	5.48E+06	1.88E+08	-1.86E+08
200	90	3.012	-33	-4.57E+06	4.25E+06	2.01E+08	-1.97E+08
200	90	3.012	-44	-3.11E+06	3.08E+06	2.12E+08	-2.06E+08
200	90	3.012	-55	-2.29E+06	2.09E+06	2.19E+08	-2.29E+08
200	100	2.857	0	-7.15E+06	6.22E+06	2.20E+08	-2.20E+08
200	100	2.857	-10	-5.65E+06	6.89E+06	2.18E+08	-2.17E+08
200	100	2.857	-20	-4.89E+06	5.91E+06	2.22E+08	-2.10E+08
200	100	2.857	-30	-4.51E+06	4.55E+06	2.34E+08	-2.27E+08
200	100	2.857	-40	-3.10E+06	3.12E+06	2.46E+08	-2.38E+08
200	100	2.857	-50	-3.80E+05	1.97E+06	2.56E+08	-2.65E+08

Lm (m)	Ls (m)	Bs (m)	Ys (m)	F_tr_sag (N)	F_tr_hog (N)
200	50	4.041	14.29	4.49E+06	-4.49E+06
200	50	4.041	15.71	4.96E+06	-4.95E+06
200	50	4.041	17.14	5.29E+06	-5.29E+06
200	50	4.041	18.57	5.47E+06	-5.47E+06
200	50	4.041	20	5.70E+06	-5.50E+06
200	50	4.041	21.43	6.14E+06	-5.36E+06
200	60	3.689	14.29	4.87E+06	-4.87E+06
200	60	3.689	15.71	5.37E+06	-5.37E+06
200	60	3.689	17.14	5.73E+06	-5.73E+06
200	60	3.689	18.57	5.93E+06	-5.93E+06
200	60	3.689	20	6.17E+06	-5.96E+06
200	60	3.689	21.43	6.65E+06	-5.81E+06
200	70	3.415	14.29	5.21E+06	-5.21E+06
200	70	3.415	15.71	5.75E+06	-5.75E+06
200	70	3.415	17.14	6.13E+06	-6.13E+06
200	70	3.415	18.57	6.35E+06	-6.34E+06
200	70	3.415	20	6.60E+06	-6.37E+06
200	70	3.415	21.43	7.11E+06	-6.22E+06
200	80	3.194	14.29	5.52E+06	-5.51E+06
200	80	3.194	15.71	6.09E+06	-6.08E+06
200	80	3.194	17.14	6.50E+06	-6.49E+06
200	80	3.194	18.57	6.73E+06	-6.71E+06
200	80	3.194	20	6.99E+06	-6.74E+06
200	80	3.194	21.43	7.53E+06	-6.58E+06
200	90	3.012	14.29	5.80E+06	-5.80E+06
200	90	3.012	15.71	6.40E+06	-6.39E+06
200	90	3.012	17.14	6.84E+06	-6.82E+06
200	90	3.012	18.57	7.07E+06	-7.05E+06
200	90	3.012	20	7.35E+06	-7.08E+06
200	90	3.012	21.43	7.92E+06	-6.91E+06
200	100	2.857	14.29	6.07E+06	-6.06E+06
200	100	2.857	15.71	6.70E+06	-6.68E+06
200	100	2.857	17.14	7.15E+06	-7.12E+06
200	100	2.857	18.57	7.40E+06	-7.37E+06
200	100	2.857	20	7.68E+06	-7.40E+06
200	100	2.857	21.43	8.27E+06	-7.22E+06

Lm (m)	Ls (m)	Bs (m)	Xs (m)	F_lg_sag (N)	F_lg_hog (N)	M_lg_pos (Nm)	M_lg_neg (Nm)
220	55	4.445	0	-8.92E+06	9.98E+06	9.69E+07	-9.69E+07
220	55	4.445	-16.5	-8.42E+06	8.43E+06	9.42E+07	-8.70E+07
220	55	4.445	-33	-7.15E+06	7.16E+06	8.87E+07	-7.74E+07
220	55	4.445	-49.5	-5.70E+06	5.70E+06	8.96E+07	-7.61E+07
220	55	4.445	-66	-4.65E+06	4.65E+06	8.23E+07	-9.10E+07
220	55	4.445	-82.5	-4.34E+06	4.69E+06	8.36E+07	-1.00E+08
220	66	4.057	0	-1.02E+07	1.02E+07	1.40E+08	-1.40E+08
220	66	4.057	-15.4	-9.47E+06	8.47E+06	1.30E+08	-1.19E+08
220	66	4.057	-30.8	-7.73E+06	7.24E+06	1.32E+08	-1.11E+08
220	66	4.057	-46.2	-5.75E+06	5.76E+06	1.33E+08	-9.25E+07
220	66	4.057	-61.6	-4.58E+06	4.58E+06	1.33E+08	-1.35E+08
220	66	4.057	-77	-4.06E+06	4.25E+06	1.17E+08	-1.50E+08
220	77	3.756	0	-1.01E+07	1.02E+07	1.86E+08	-1.86E+08
220	77	3.756	-14.3	-9.48E+06	8.26E+06	1.77E+08	-1.81E+08
220	77	3.756	-28.6	-7.85E+06	7.10E+06	1.79E+08	-1.36E+08
220	77	3.756	-42.9	-5.85E+06	5.65E+06	1.81E+08	-1.80E+08
220	77	3.756	-57.2	-4.38E+06	4.39E+06	1.82E+08	-1.83E+08
220	77	3.756	-71.5	-3.67E+06	3.78E+06	1.82E+08	-2.05E+08
220	88	3.514	0	-1.01E+07	9.94E+06	2.30E+08	-2.30E+08
220	88	3.514	-13.2	-9.27E+06	9.36E+06	2.26E+08	-2.24E+08
220	88	3.514	-26.4	-7.79E+06	7.83E+06	2.29E+08	-2.10E+08
220	88	3.514	-39.6	-5.87E+06	5.39E+06	2.32E+08	-2.28E+08
220	88	3.514	-52.8	-4.19E+06	4.19E+06	2.33E+08	-2.48E+08
220	88	3.514	-66	-3.32E+06	3.32E+06	2.33E+08	-2.63E+08
220	99	3.313	0	-9.35E+06	9.50E+06	2.67E+08	-2.67E+08
220	99	3.313	-12.1	-9.28E+06	8.99E+06	2.74E+08	-2.60E+08
220	99	3.313	-24.2	-7.56E+06	7.62E+06	2.77E+08	-2.44E+08
220	99	3.313	-36.3	-5.78E+06	5.80E+06	2.80E+08	-2.75E+08
220	99	3.313	-48.4	-4.07E+06	4.07E+06	2.83E+08	-3.00E+08
220	99	3.313	-60.5	-2.92E+06	2.93E+06	2.84E+08	-3.19E+08
220	110	3.143	0	-8.98E+06	8.90E+06	3.13E+08	-3.13E+08
220	110	3.143	-11	-7.78E+06	8.46E+06	3.15E+08	-2.87E+08
220	110	3.143	-22	-6.72E+06	7.73E+06	3.19E+08	-2.69E+08
220	110	3.143	-33	-5.89E+06	5.62E+06	3.23E+08	-3.16E+08
220	110	3.143	-44	-3.99E+06	3.93E+06	3.27E+08	-3.47E+08
220	110	3.143	-55	-4.37E+05	2.61E+06	3.29E+08	-3.68E+08

Lm (m)	Ls (m)	Bs (m)	Ys (m)	F_tr_sag (N)	F_tr_hog (N)
220	55	4.445	15.71	5.84E+06	-5.84E+06
220	55	4.445	17.29	6.27E+06	-6.27E+06
220	55	4.445	18.86	6.32E+06	-6.48E+06
220	55	4.445	20.43	6.96E+06	-6.46E+06
220	55	4.445	22	7.52E+06	-6.21E+06
220	55	4.445	23.57	7.96E+06	-7.96E+06
220	66	4.057	15.71	6.33E+06	-6.33E+06
220	66	4.057	17.29	6.80E+06	-6.80E+06
220	66	4.057	18.86	6.85E+06	-7.03E+06
220	66	4.057	20.43	7.55E+06	-7.01E+06
220	66	4.057	22	8.14E+06	-6.73E+06
220	66	4.057	23.57	8.63E+06	-6.23E+06
220	77	3.756	15.71	6.77E+06	-6.77E+06
220	77	3.756	17.29	7.27E+06	-7.27E+06
220	77	3.756	18.86	7.32E+06	-7.52E+06
220	77	3.756	20.43	8.07E+06	-7.50E+06
220	77	3.756	22	8.71E+06	-7.20E+06
220	77	3.756	23.57	9.22E+06	-6.66E+06
220	88	3.514	15.71	7.18E+06	-7.17E+06
220	88	3.514	17.29	7.71E+06	-7.71E+06
220	88	3.514	18.86	7.75E+06	-7.97E+06
220	88	3.514	20.43	8.54E+06	-7.94E+06
220	88	3.514	22	9.22E+06	-7.63E+06
220	88	3.514	23.57	9.77E+06	-7.06E+06
220	99	3.313	15.71	7.55E+06	-7.54E+06
220	99	3.313	17.29	8.11E+06	-8.10E+06
220	99	3.313	18.86	8.15E+06	-8.38E+06
220	99	3.313	20.43	8.98E+06	-8.35E+06
220	99	3.313	22	9.70E+06	-8.03E+06
220	99	3.313	23.57	1.03E+07	-7.42E+06
220	110	3.143	15.71	7.89E+06	-7.89E+06
220	110	3.143	17.29	8.48E+06	-8.47E+06
220	110	3.143	18.86	8.52E+06	-8.75E+06
220	110	3.143	20.43	9.39E+06	-8.73E+06
220	110	3.143	22	1.01E+07	-8.39E+06
220	110	3.143	23.57	1.07E+07	-7.76E+06

Lm (m)	Ls (m)	Bs (m)	Xs (m)	F_lg_sag (N)	F_lg_hog (N)	M_lg_pos (Nm)	M_lg_neg (Nm)
240	60	4.849	0	-1.22E+07	1.22E+07	1.33E+08	-1.33E+08
240	60	4.849	-18	-1.14E+07	1.14E+07	1.27E+08	-1.28E+08
240	60	4.849	-36	-9.33E+06	8.63E+06	1.24E+08	-1.11E+08
240	60	4.849	-54	-7.13E+06	7.07E+06	1.20E+08	-1.11E+08
240	60	4.849	-72	-5.87E+06	5.87E+06	1.18E+08	-1.30E+08
240	60	4.849	-90	-6.06E+06	6.06E+06	1.18E+08	-1.39E+08
240	72	4.426	0	-1.24E+07	1.24E+07	1.90E+08	-1.90E+08
240	72	4.426	-16.8	-1.16E+07	1.16E+07	1.87E+08	-1.83E+08
240	72	4.426	-33.6	-9.61E+06	9.61E+06	1.82E+08	-1.46E+08
240	72	4.426	-50.4	-7.34E+06	7.34E+06	1.77E+08	-1.45E+08
240	72	4.426	-67.2	-5.80E+06	5.80E+06	1.73E+08	-1.93E+08
240	72	4.426	-84	-5.56E+06	5.56E+06	1.61E+08	-2.09E+08
240	84	4.098	0	-1.30E+07	1.23E+07	2.54E+08	-2.54E+08
240	84	4.098	-15.6	-1.22E+07	1.15E+07	2.53E+08	-2.38E+08
240	84	4.098	-31.2	-9.63E+06	9.64E+06	2.47E+08	-2.18E+08
240	84	4.098	-46.8	-7.38E+06	7.38E+06	2.53E+08	-2.51E+08
240	84	4.098	-62.4	-5.62E+06	5.62E+06	2.34E+08	-2.63E+08
240	84	4.098	-78	-4.97E+06	4.97E+06	2.31E+08	-2.88E+08
240	96	3.833	0	-1.25E+07	1.18E+07	3.21E+08	-3.21E+08
240	96	3.833	-14.4	-1.20E+07	1.12E+07	3.19E+08	-2.87E+08
240	96	3.833	-28.8	-1.00E+07	9.44E+06	3.13E+08	-2.63E+08
240	96	3.833	-43.2	-7.41E+06	7.26E+06	3.25E+08	-3.21E+08
240	96	3.833	-57.6	-5.36E+06	5.36E+06	3.42E+08	-3.36E+08
240	96	3.833	-72	-4.35E+06	4.35E+06	2.90E+08	-3.70E+08
240	108	3.614	0	-1.21E+07	1.12E+07	3.83E+08	-3.83E+08
240	108	3.614	-13.2	-1.15E+07	1.18E+07	3.81E+08	-3.79E+08
240	108	3.614	-26.4	-9.86E+06	9.03E+06	3.74E+08	-3.71E+08
240	108	3.614	-39.6	-7.44E+06	6.99E+06	3.95E+08	-3.88E+08
240	108	3.614	-52.8	-5.07E+06	5.05E+06	4.17E+08	-4.07E+08
240	108	3.614	-66	-3.75E+06	3.42E+06	4.33E+08	-4.18E+08
240	120	3.429	0	-9.46E+06	1.18E+07	4.35E+08	-4.35E+08
240	120	3.429	-12	-1.03E+07	1.12E+07	4.34E+08	-4.31E+08
240	120	3.429	-24	-7.81E+06	9.59E+06	4.26E+08	-4.22E+08
240	120	3.429	-36	-7.33E+06	7.38E+06	4.59E+08	-4.49E+08
240	120	3.429	-48	-5.05E+06	5.07E+06	4.85E+08	-4.70E+08
240	120	3.429	-60	-6.92E+05	3.21E+06	5.07E+08	-5.21E+08

Lm (m)	Ls (m)	Bs (m)	Ys (m)	F_tr_sag (N)	F_tr_hog (N)
240	60	4.849	17.14	7.22E+06	-7.22E+06
240	60	4.849	18.86	7.39E+06	-7.50E+06
240	60	4.849	20.57	8.22E+06	-7.46E+06
240	60	4.849	22.29	8.92E+06	-8.92E+06
240	60	4.849	24	9.46E+06	-9.46E+06
240	60	4.849	25.71	9.82E+06	-9.82E+06
240	72	4.426	17.14	7.83E+06	-7.83E+06
240	72	4.426	18.86	8.01E+06	-8.14E+06
240	72	4.426	20.57	8.91E+06	-8.10E+06
240	72	4.426	22.29	9.67E+06	-7.71E+06
240	72	4.426	24	1.03E+07	-1.03E+07
240	72	4.426	25.71	1.07E+07	-1.06E+07
240	84	4.098	17.14	8.38E+06	-8.38E+06
240	84	4.098	18.86	8.57E+06	-8.72E+06
240	84	4.098	20.57	9.53E+06	-8.67E+06
240	84	4.098	22.29	1.03E+07	-8.25E+06
240	84	4.098	24	1.10E+07	-1.10E+07
240	84	4.098	25.71	1.14E+07	-1.14E+07
240	96	3.833	17.14	8.89E+06	-8.88E+06
240	96	3.833	18.86	9.07E+06	-9.24E+06
240	96	3.833	20.57	1.01E+07	-9.19E+06
240	96	3.833	22.29	1.10E+07	-8.74E+06
240	96	3.833	24	1.16E+07	-7.92E+06
240	96	3.833	25.71	1.21E+07	-1.20E+07
240	108	3.614	17.14	9.35E+06	-9.34E+06
240	108	3.614	18.86	9.54E+06	-9.72E+06
240	108	3.614	20.57	1.06E+07	-9.67E+06
240	108	3.614	22.29	1.15E+07	-9.20E+06
240	108	3.614	24	1.22E+07	-8.34E+06
240	108	3.614	25.71	1.27E+07	-1.27E+07
240	120	3.429	17.14	9.78E+06	-9.77E+06
240	120	3.429	18.86	9.97E+06	-1.02E+07
240	120	3.429	20.57	1.11E+07	-1.01E+07
240	120	3.429	22.29	1.20E+07	-9.62E+06
240	120	3.429	24	1.28E+07	-8.72E+06
240	120	3.429	25.71	1.33E+07	-1.32E+07

Lm (m)	Ls (m)	Bs (m)	Xs (m)	F_lg_sag (N)	F_lg_hog (N)	M_lg_pos (Nm)	M_lg_neg (Nm)
260	65	5.253	0	-1.43E+07	1.56E+07	1.73E+08	-1.73E+08
260	65	5.253	-19.5	-1.35E+07	1.35E+07	1.74E+08	-1.67E+08
260	65	5.253	-39	-1.13E+07	1.13E+07	1.65E+08	-1.47E+08
260	65	5.253	-58.5	-8.95E+06	8.95E+06	1.67E+08	-1.48E+08
260	65	5.253	-78	-7.35E+06	7.35E+06	1.50E+08	-1.76E+08
260	65	5.253	-97.5	-7.06E+06	7.29E+06	1.61E+08	-1.83E+08
260	78	4.795	0	-1.59E+07	1.60E+07	2.60E+08	-2.60E+08
260	78	4.795	-18.2	-1.48E+07	1.36E+07	2.54E+08	-2.33E+08
260	78	4.795	-36.4	-1.21E+07	1.15E+07	2.43E+08	-2.14E+08
260	78	4.795	-54.6	-9.08E+06	9.08E+06	2.48E+08	-1.88E+08
260	78	4.795	-72.8	-7.23E+06	7.23E+06	2.51E+08	-2.47E+08
260	78	4.795	-91	-6.57E+06	6.59E+06	2.21E+08	-2.74E+08
260	91	4.439	0	-1.59E+07	1.60E+07	3.47E+08	-3.47E+08
260	91	4.439	-16.9	-1.49E+07	1.33E+07	3.40E+08	-2.96E+08
260	91	4.439	-33.8	-1.23E+07	1.14E+07	3.31E+08	-2.71E+08
260	91	4.439	-50.7	-9.13E+06	8.95E+06	3.39E+08	-3.37E+08
260	91	4.439	-67.6	-6.94E+06	6.94E+06	3.44E+08	-3.36E+08
260	91	4.439	-84.5	-5.93E+06	5.86E+06	2.88E+08	-3.76E+08
260	104	4.153	0	-1.47E+07	1.56E+07	4.32E+08	-4.32E+08
260	104	4.153	-15.6	-1.48E+07	1.47E+07	4.16E+08	-4.24E+08
260	104	4.153	-31.2	-1.22E+07	1.09E+07	4.24E+08	-4.02E+08
260	104	4.153	-46.8	-9.18E+06	8.61E+06	4.33E+08	-4.28E+08
260	104	4.153	-62.4	-6.53E+06	6.53E+06	4.41E+08	-4.60E+08
260	104	4.153	-78	-5.16E+06	5.16E+06	4.44E+08	-4.83E+08
260	117	3.915	0	-1.44E+07	1.49E+07	5.08E+08	-5.08E+08
260	117	3.915	-14.3	-1.44E+07	1.41E+07	5.04E+08	-4.98E+08
260	117	3.915	-28.6	-1.22E+07	1.19E+07	5.13E+08	-4.74E+08
260	117	3.915	-42.9	-9.06E+06	9.08E+06	5.25E+08	-5.17E+08
260	117	3.915	-57.2	-6.35E+06	6.36E+06	5.36E+08	-5.57E+08
260	117	3.915	-71.5	-4.55E+06	4.55E+06	5.42E+08	-5.86E+08
260	130	3.714	0	-1.38E+07	1.40E+07	5.67E+08	-5.67E+08
260	130	3.714	-13	-1.18E+07	1.33E+07	5.82E+08	-5.57E+08
260	130	3.714	-26	-1.02E+07	1.19E+07	5.93E+08	-5.30E+08
260	130	3.714	-39	-9.12E+06	9.16E+06	6.07E+08	-5.96E+08
260	130	3.714	-52	-6.17E+06	6.15E+06	6.20E+08	-6.44E+08
260	130	3.714	-65	-7.55E+05	4.07E+06	6.30E+08	-6.78E+08

Lm (m)	Ls (m)	Bs (m)	Ys (m)	F_tr_sag (N)	F_tr_hog (N)
260	65	5.253	18.57	8.34E+06	-8.52E+06
260	65	5.253	20.43	9.41E+06	-9.41E+06
260	65	5.253	22.29	1.03E+07	-1.03E+07
260	65	5.253	24.14	1.10E+07	-1.10E+07
260	65	5.253	26	1.14E+07	-1.14E+07
260	65	5.253	27.86	1.19E+07	-1.16E+07
260	78	4.795	18.57	9.04E+06	-9.25E+06
260	78	4.795	20.43	1.02E+07	-9.26E+06
260	78	4.795	22.29	1.12E+07	-1.12E+07
260	78	4.795	24.14	1.19E+07	-1.19E+07
260	78	4.795	26	1.24E+07	-1.24E+07
260	78	4.795	27.86	1.29E+07	-1.26E+07
260	91	4.439	18.57	9.67E+06	-9.91E+06
260	91	4.439	20.43	1.09E+07	-9.91E+06
260	91	4.439	22.29	1.20E+07	-1.19E+07
260	91	4.439	24.14	1.27E+07	-1.27E+07
260	91	4.439	26	1.32E+07	-1.32E+07
260	91	4.439	27.86	1.38E+07	-1.34E+07
260	104	4.153	18.57	1.02E+07	-1.05E+07
260	104	4.153	20.43	1.16E+07	-1.05E+07
260	104	4.153	22.29	1.27E+07	-9.96E+06
260	104	4.153	24.14	1.35E+07	-1.35E+07
260	104	4.153	26	1.40E+07	-1.40E+07
260	104	4.153	27.86	1.46E+07	-1.42E+07
260	117	3.915	18.57	1.08E+07	-1.11E+07
260	117	3.915	20.43	1.22E+07	-1.11E+07
260	117	3.915	22.29	1.33E+07	-1.05E+07
260	117	3.915	24.14	1.42E+07	-1.42E+07
260	117	3.915	26	1.47E+07	-1.47E+07
260	117	3.915	27.86	1.53E+07	-1.49E+07
260	130	3.714	18.57	1.13E+07	-1.16E+07
260	130	3.714	20.43	1.27E+07	-1.16E+07
260	130	3.714	22.29	1.39E+07	-1.10E+07
260	130	3.714	24.14	1.48E+07	-1.48E+07
260	130	3.714	26	1.54E+07	-1.54E+07
260	130	3.714	27.86	1.60E+07	-1.56E+07

Lm (m)	Ls (m)	Bs (m)	Xs (m)	F_lg_sag (N)	F_lg_hog (N)	M_lg_pos (Nm)	M_lg_neg (Nm)
280	70	5.657	0	-1.86E+07	1.86E+07	2.37E+08	-2.37E+08
280	70	5.657	-21	-1.73E+07	1.73E+07	2.21E+08	-2.10E+08
280	70	5.657	-42	-1.41E+07	1.34E+07	2.18E+08	-1.88E+08
280	70	5.657	-63	-1.08E+07	1.08E+07	2.15E+08	-1.86E+08
280	70	5.657	-84	-8.67E+06	8.78E+06	2.00E+08	-2.26E+08
280	70	5.657	-105	-9.17E+06	9.17E+06	2.05E+08	-2.42E+08
280	84	5.164	0	-1.89E+07	1.89E+07	3.41E+08	-3.41E+08
280	84	5.164	-19.6	-1.77E+07	1.77E+07	3.26E+08	-3.31E+08
280	84	5.164	-39.2	-1.46E+07	1.34E+07	3.23E+08	-2.69E+08
280	84	5.164	-58.8	-1.11E+07	1.08E+07	3.18E+08	-2.30E+08
280	84	5.164	-78.4	-8.67E+06	8.67E+06	3.14E+08	-3.35E+08
280	84	5.164	-98	-8.39E+06	8.39E+06	2.85E+08	-3.63E+08
280	98	4.781	0	-1.86E+07	1.88E+07	4.50E+08	-4.50E+08
280	98	4.781	-18.2	-1.82E+07	1.76E+07	4.42E+08	-4.37E+08
280	98	4.781	-36.4	-1.47E+07	1.47E+07	4.39E+08	-4.05E+08
280	98	4.781	-54.6	-1.12E+07	1.12E+07	4.33E+08	-4.42E+08
280	98	4.781	-72.8	-8.43E+06	8.14E+06	4.27E+08	-4.58E+08
280	98	4.781	-91	-7.48E+06	7.48E+06	4.23E+08	-5.01E+08
280	112	4.472	0	-1.84E+07	1.82E+07	5.51E+08	-5.51E+08
280	112	4.472	-16.8	-1.80E+07	1.71E+07	5.62E+08	-5.36E+08
280	112	4.472	-33.6	-1.50E+07	1.44E+07	5.57E+08	-4.97E+08
280	112	4.472	-50.4	-1.11E+07	1.10E+07	5.71E+08	-5.47E+08
280	112	4.472	-67.2	-8.09E+06	8.09E+06	6.05E+08	-5.86E+08
280	112	4.472	-84	-6.56E+06	6.56E+06	5.37E+08	-6.46E+08
280	126	4.216	0	-1.79E+07	1.86E+07	6.75E+08	-6.75E+08
280	126	4.216	-15.4	-1.70E+07	1.76E+07	6.75E+08	-6.18E+08
280	126	4.216	-30.8	-1.48E+07	1.39E+07	6.70E+08	-5.73E+08
280	126	4.216	-46.2	-1.11E+07	1.07E+07	6.95E+08	-6.57E+08
280	126	4.216	-61.6	-7.56E+06	7.67E+06	7.39E+08	-7.10E+08
280	126	4.216	-77	-5.68E+06	5.68E+06	7.73E+08	-7.86E+08
280	140	4	0	-1.71E+07	1.76E+07	7.73E+08	-7.73E+08
280	140	4	-14	-1.49E+07	1.67E+07	7.72E+08	-7.69E+08
280	140	4	-28	-1.29E+07	1.43E+07	7.68E+08	-7.61E+08
280	140	4	-42	-1.08E+07	1.10E+07	8.07E+08	-7.93E+08
280	140	4	-56	-7.54E+06	7.56E+06	8.60E+08	-8.21E+08
280	140	4	-70	-4.74E+06	4.76E+06	9.05E+08	-9.12E+08

Lm (m)	Ls (m)	Bs (m)	Ys (m)	F_tr_sag (N)	F_tr_hog (N)
280	70	5.657	20	1.05E+07	-1.05E+07
280	70	5.657	22	1.16E+07	-1.16E+07
280	70	5.657	24	1.25E+07	-1.25E+07
280	70	5.657	26	1.30E+07	-1.30E+07
280	70	5.657	28	1.37E+07	-1.32E+07
280	70	5.657	30	1.47E+07	-1.31E+07
280	84	5.164	20	1.13E+07	-1.13E+07
280	84	5.164	22	1.26E+07	-1.26E+07
280	84	5.164	24	1.35E+07	-1.35E+07
280	84	5.164	26	1.41E+07	-1.41E+07
280	84	5.164	28	1.49E+07	-1.43E+07
280	84	5.164	30	1.59E+07	-1.42E+07
280	98	4.781	20	1.21E+07	-1.12E+07
280	98	4.781	22	1.35E+07	-1.35E+07
280	98	4.781	24	1.45E+07	-1.45E+07
280	98	4.781	26	1.51E+07	-1.51E+07
280	98	4.781	28	1.59E+07	-1.53E+07
280	98	4.781	30	1.70E+07	-1.52E+07
280	112	4.472	20	1.28E+07	-1.19E+07
280	112	4.472	22	1.43E+07	-1.43E+07
280	112	4.472	24	1.53E+07	-1.53E+07
280	112	4.472	26	1.60E+07	-1.60E+07
280	112	4.472	28	1.68E+07	-1.63E+07
280	112	4.472	30	1.80E+07	-1.61E+07
280	126	4.216	20	1.35E+07	-1.25E+07
280	126	4.216	22	1.50E+07	-1.19E+07
280	126	4.216	24	1.61E+07	-1.61E+07
280	126	4.216	26	1.68E+07	-1.68E+07
280	126	4.216	28	1.77E+07	-1.71E+07
280	126	4.216	30	1.90E+07	-1.69E+07
280	140	4	20	1.41E+07	-1.31E+07
280	140	4	22	1.57E+07	-1.25E+07
280	140	4	24	1.69E+07	-1.69E+07
280	140	4	26	1.76E+07	-1.76E+07
280	140	4	28	1.85E+07	-1.79E+07
280	140	4	30	1.98E+07	-1.76E+07

Lm (m)	Ls (m)	Bs (m)	Xs (m)	F_lg_sag (N)	F_lg_hog (N)	M_lg_pos (Nm)	M_lg_neg (Nm)
300	75	6.061	0	-2.15E+07	2.27E+07	3.02E+08	-3.02E+08
300	75	6.061	-22.5	-2.10E+07	2.02E+07	2.93E+08	-2.91E+08
300	75	6.061	-45	-1.68E+07	1.68E+07	2.82E+08	-2.52E+08
300	75	6.061	-67.5	-1.31E+07	1.31E+07	2.83E+08	-2.52E+08
300	75	6.061	-90	-1.08E+07	1.08E+07	2.56E+08	-2.95E+08
300	75	6.061	-112.5	-1.07E+07	1.07E+07	2.69E+08	-3.02E+08
300	90	5.533	0	-2.32E+07	2.32E+07	4.30E+08	-4.30E+08
300	90	5.533	-21	-2.16E+07	2.04E+07	4.30E+08	-4.15E+08
300	90	5.533	-42	-1.71E+07	1.71E+07	4.14E+08	-3.32E+08
300	90	5.533	-63	-1.33E+07	1.33E+07	4.20E+08	-3.30E+08
300	90	5.533	-84	-1.06E+07	1.06E+07	3.85E+08	-4.39E+08
300	90	5.533	-105	-9.90E+06	9.90E+06	3.84E+08	-4.50E+08
300	105	5.122	0	-2.27E+07	2.32E+07	5.86E+08	-5.86E+08
300	105	5.122	-19.5	-2.17E+07	2.01E+07	5.79E+08	-5.38E+08
300	105	5.122	-39	-1.79E+07	1.70E+07	5.55E+08	-4.92E+08
300	105	5.122	-58.5	-1.32E+07	1.33E+07	5.75E+08	-5.72E+08
300	105	5.122	-78	-1.02E+07	1.02E+07	5.91E+08	-6.01E+08
300	105	5.122	-97.5	-8.90E+06	8.90E+06	5.10E+08	-6.18E+08
300	120	4.792	0	-2.24E+07	2.27E+07	7.37E+08	-7.37E+08
300	120	4.792	-18	-2.11E+07	2.14E+07	7.28E+08	-6.47E+08
300	120	4.792	-36	-1.78E+07	1.65E+07	7.10E+08	-7.02E+08
300	120	4.792	-54	-1.33E+07	1.29E+07	7.37E+08	-7.30E+08
300	120	4.792	-72	-9.40E+06	9.65E+06	7.60E+08	-7.70E+08
300	120	4.792	-90	-7.79E+06	7.79E+06	7.73E+08	-7.95E+08
300	135	4.518	0	-2.18E+07	2.18E+07	8.74E+08	-8.74E+08
300	135	4.518	-16.5	-2.06E+07	2.06E+07	8.65E+08	-8.63E+08
300	135	4.518	-33	-1.74E+07	1.75E+07	8.63E+08	-8.35E+08
300	135	4.518	-49.5	-1.32E+07	1.32E+07	8.94E+08	-8.83E+08
300	135	4.518	-66	-9.20E+06	9.21E+06	9.25E+08	-9.33E+08
300	135	4.518	-82.5	-6.52E+06	6.52E+06	9.46E+08	-9.67E+08
300	150	4.286	0	-1.69E+07	2.05E+07	9.87E+08	-9.87E+08
300	150	4.286	-15	-1.61E+07	1.95E+07	9.78E+08	-9.75E+08
300	150	4.286	-30	-1.59E+07	1.67E+07	9.99E+08	-9.44E+08
300	150	4.286	-45	-1.22E+07	1.29E+07	1.04E+09	-1.02E+09
300	150	4.286	-60	-8.82E+06	8.96E+06	1.07E+09	-1.08E+09
300	150	4.286	-75	-5.86E+06	5.87E+06	1.10E+09	-1.12E+09

Lm (m)	Ls (m)	Bs (m)	Ys (m)	F_tr_sag (N)	F_tr_hog (N)
300	75	6.061	21.43	1.27E+07	-1.27E+07
300	75	6.061	23.57	1.39E+07	-1.39E+07
300	75	6.061	25.71	1.47E+07	-1.47E+07
300	75	6.061	27.86	1.55E+07	-1.49E+07
300	75	6.061	30	1.67E+07	-1.48E+07
300	75	6.061	32.14	1.77E+07	-1.41E+07
300	90	5.533	21.43	1.38E+07	-1.38E+07
300	90	5.533	23.57	1.51E+07	-1.51E+07
300	90	5.533	25.71	1.59E+07	-1.59E+07
300	90	5.533	27.86	1.68E+07	-1.62E+07
300	90	5.533	30	1.81E+07	-1.60E+07
300	90	5.533	32.14	1.92E+07	-1.53E+07
300	105	5.122	21.43	1.48E+07	-1.48E+07
300	105	5.122	23.57	1.61E+07	-1.61E+07
300	105	5.122	25.71	1.70E+07	-1.70E+07
300	105	5.122	27.86	1.79E+07	-1.73E+07
300	105	5.122	30	1.94E+07	-1.71E+07
300	105	5.122	32.14	2.05E+07	-1.64E+07
300	120	4.792	21.43	1.56E+07	-1.56E+07
300	120	4.792	23.57	1.71E+07	-1.71E+07
300	120	4.792	25.71	1.80E+07	-1.80E+07
300	120	4.792	27.86	1.90E+07	-1.84E+07
300	120	4.792	30	2.05E+07	-1.81E+07
300	120	4.792	32.14	2.17E+07	-1.73E+07
300	135	4.518	21.43	1.65E+07	-1.65E+07
300	135	4.518	23.57	1.80E+07	-1.80E+07
300	135	4.518	25.71	1.89E+07	-1.89E+07
300	135	4.518	27.86	2.00E+07	-1.93E+07
300	135	4.518	30	2.16E+07	-1.91E+07
300	135	4.518	32.14	2.28E+07	-1.82E+07
300	150	4.286	21.43	1.72E+07	-1.72E+07
300	150	4.286	23.57	1.88E+07	-1.88E+07
300	150	4.286	25.71	1.98E+07	-1.98E+07
300	150	4.286	27.86	2.09E+07	-2.02E+07
300	150	4.286	30	2.25E+07	-1.99E+07
300	150	4.286	32.14	2.39E+07	-1.91E+07

Appendix C. Wave Height Matching Reliability Index of Five

Where the required variables in this algorithm are contained in Appendix A

```

design_wave := new
                1,D ← 0·m
                for q ∈ 1..D
                    mean ← 0
                    m2 ← 0
                    design ← 0
                    h ← 0
                    sum ← ∑p=1pmaxq ssp,q
                    for p ∈ 1..2B
                        if ssp,q ≠ 0
                            h ← hwp
                            mean ← mean + |h| ·  $\frac{ss_{p,q}}{sum}$ 
                            m2 ← m2 + (h)2 ·  $\frac{ss_{p,q}}{sum}$ 
                    design ←  $\left[ mean + \beta \sqrt{m2 - (mean)^2} \right]$ 
                    new1,q ← design
                new
    
```

Page Intentionally Left Blank

Appendix D. Fit Parameters for Analytical Thesis Model

Actual by Predicted Plot Longitudinal Troughing

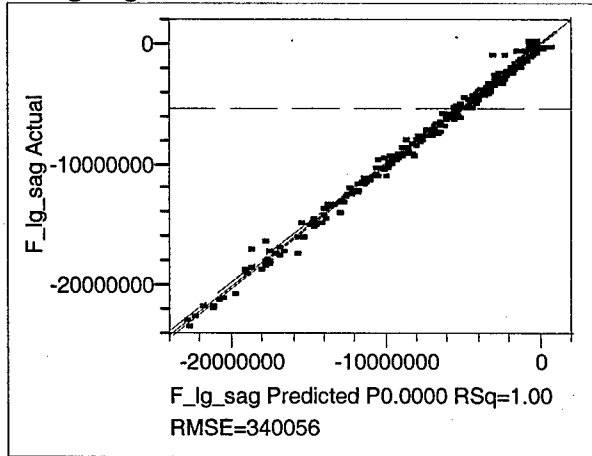

Summary of Fit Longitudinal Troughing

RSquare	0.996193
RSquare Adj	0.995996
Root Mean Square Error	340056
Mean of Response	-5293391
Observations (or Sum Wgts)	468

$$\begin{aligned}
 F_{\text{trough}} = & 3211000 + -61810L_m + 2225000 \frac{L_s}{L_m} - 10020000 \frac{X_s}{L_m} - 273.9(L_m - 180)^2 \dots \\
 & + 76210 \left(\frac{L_s}{L_m} - 0.375 \right) \cdot (L_m - 180) - 136600 \left(\frac{X_s}{L_m} + 0.3125 \right) \cdot (L_m - 180) \dots \\
 & + -18420000 \left(\frac{L_s}{L_m} - 0.375 \right) \cdot \left(\frac{X_s}{L_m} + 0.3125 \right) - 2475000 \left(\frac{X_s}{L_m} + 0.3125 \right)^2 \dots \\
 & + -0.2781(L_m - 180)^3 + 408.3(L_m - 180)^2 \cdot \left(\frac{L_s}{L_m} - 0.375 \right) + 491600 \left(\frac{L_s}{L_m} - 0.375 \right)^2 \cdot (L_m - 180) \dots \\
 & + -371.6(L_m - 180)^2 \cdot \left(\frac{X_s}{L_m} + 0.3125 \right) - 105500(L_m - 180) \cdot \left(\frac{L_s}{L_m} - 0.375 \right) \cdot \left(\frac{X_s}{L_m} + 0.3125 \right) \dots \\
 & + 26770 \left(\frac{X_s}{L_m} + 0.3125 \right)^2 \cdot (L_m - 180) + 170200000 \left(\frac{L_s}{L_m} - 0.375 \right)^3 \dots \\
 & + 21070000 \left(\frac{X_s}{L_m} + 0.3125 \right)^2 \cdot \left(\frac{L_s}{L_m} - 0.375 \right) + 37440000 \left(\frac{X_s}{L_m} + 0.3125 \right)^3 \dots \\
 & + 1225(L_m - 180)^2 \cdot \left(\frac{L_s}{L_m} - 0.375 \right)^2 + 483500 \left(\frac{L_s}{L_m} - 0.375 \right)^2 \cdot (L_m - 180) \cdot \left(\frac{X_s}{L_m} + 0.3125 \right) \dots \\
 & + 416000 \left(\frac{X_s}{L_m} + 0.3125 \right)^3 \cdot (L_m - 180) + 191100000 \left(\frac{L_s}{L_m} - 0.375 \right)^4 \dots \\
 & + 285700000 \left(\frac{L_s}{L_m} - 0.375 \right)^2 \cdot \left(\frac{X_s}{L_m} + 0.3125 \right)^2 + 28010000 \left(\frac{X_s}{L_m} + 0.3125 \right)^4
 \end{aligned}$$

Actual by Predicted Plot Longitudinal Cresting

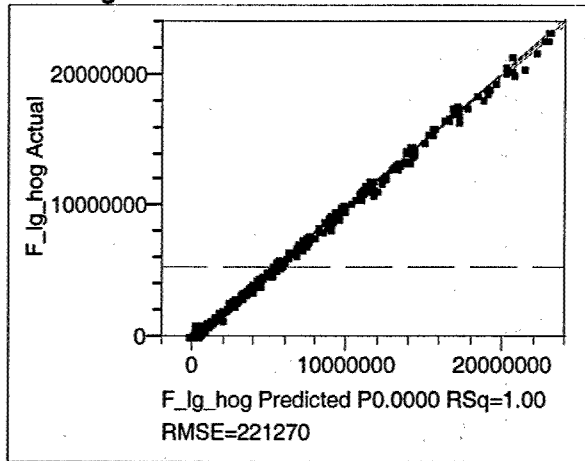

Summary of Fit Longitudinal Cresting

RSquare	0.998383
RSquare Adj	0.998295
Root Mean Square Error	221269.5
Mean of Response	5328974
Observations (or Sum Wgts)	468

$$\begin{aligned}
 F_{\text{crest}} = & -2703000 + 58190L_m + -3016000\frac{L_s}{L_m} + 9039000\frac{X_s}{L_m} + 269.00(L_m - 180)^2 \dots \\
 & + -50870\left(\frac{L_s}{L_m} - 0.375\right) \cdot (L_m - 180) + 118600\left(\frac{X_s}{L_m} + 0.3125\right) \cdot (L_m - 180) \dots \\
 & + 19850000\left(\frac{L_s}{L_m} - 0.375\right) \cdot \left(\frac{X_s}{L_m} + 0.3125\right) + 0.3331(L_m - 180)^3 \dots \\
 & + -327.5(L_m - 180)^2 \cdot \left(\frac{L_s}{L_m} - 0.375\right) + -255700\left(\frac{L_s}{L_m} - 0.375\right)^2 \cdot (L_m - 180) \dots \\
 & + 451.3(L_m - 180)^2 \cdot \left(\frac{X_s}{L_m} + 0.3125\right) + 157300(L_m - 180) \cdot \left(\frac{L_s}{L_m} - 0.375\right) \cdot \left(\frac{X_s}{L_m} + 0.3125\right) \dots \\
 & + -11470000\left(\frac{X_s}{L_m} + 0.3125\right)^2 \cdot \left(\frac{L_s}{L_m} - 0.375\right) + -36160000\left(\frac{X_s}{L_m} + 0.3125\right)^3 \dots \\
 & + -0.8241(L_m - 180)^3 \cdot \left(\frac{L_s}{L_m} - 0.375\right) + -1240(L_m - 180)^2 \cdot \left(\frac{L_s}{L_m} - 0.375\right)^2 \dots \\
 & + 0.5652(L_m - 180)^3 \cdot \left(\frac{X_s}{L_m} + 0.3125\right) + 934.7(L_m - 180)^2 \cdot \left(\frac{X_s}{L_m} + 0.3125\right) \cdot \left(\frac{L_s}{L_m} - 0.375\right) \dots \\
 & + 143.3(L_m - 180)^2 \cdot \left(\frac{X_s}{L_m} + 0.3125\right)^2 + 364600\left(\frac{L_s}{L_m} - 0.375\right)^2 \cdot (L_m - 180) \cdot \left(\frac{X_s}{L_m} + 0.3125\right) \dots \\
 & + -122200\left(\frac{X_s}{L_m} + 0.3125\right)^2 \cdot (L_m - 180) \cdot \left(\frac{L_s}{L_m} - 0.375\right) + -310300\left(\frac{X_s}{L_m} + 0.3125\right)^3 \cdot (L_m - 180) \dots \\
 & + -64030000\left(\frac{L_s}{L_m} - 0.375\right)^4 + -157300000\left(\frac{X_s}{L_m} + 0.3125\right)^3 \cdot \left(\frac{L_s}{L_m} - 0.375\right)
 \end{aligned}$$

Actual by Predicted Plot Positive Twisting

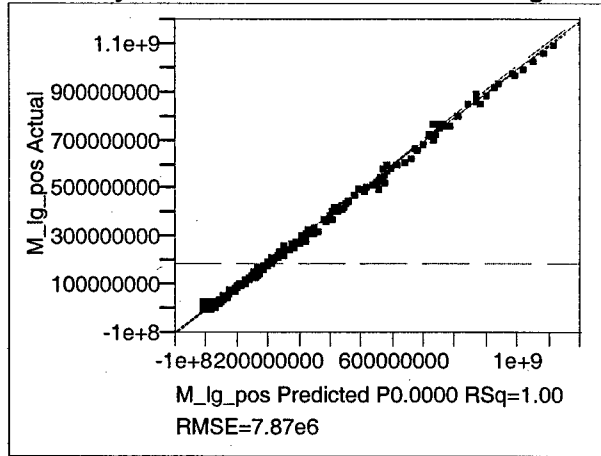

Summary of Fit Positive Twisting

RSquare	0.998925
RSquare Adj	0.998862
Root Mean Square Error	7872087
Mean of Response	1.8625e8
Observations (or Sum Wgts)	468

$$\begin{aligned}
 M_{pos} = & -454800000 + 1990000L_m + 507700000 \frac{L_s}{L_m} + -13040000 \frac{X_s}{L_m} + 15350(L_m - 180)^2 \dots \\
 & + 10620000 \left(\frac{L_s}{L_m} - 0.375 \right) \cdot (L_m - 180) + -178900 \left(\frac{X_s}{L_m} + 0.3125 \right) \cdot (L_m - 180) \dots \\
 & + -412500000 \left(\frac{L_s}{L_m} - 0.375 \right) \cdot \left(\frac{X_s}{L_m} + 0.3125 \right) + 48.54(L_m - 180)^3 \dots \\
 & + 76560(L_m - 180)^2 \cdot \left(\frac{L_s}{L_m} - 0.375 \right) + 5028000 \left(\frac{L_s}{L_m} - 0.375 \right)^2 \cdot (L_m - 180) \dots \\
 & + -1562(L_m - 180)^2 \cdot \left(\frac{X_s}{L_m} + 0.3125 \right) + -5227000(L_m - 180) \cdot \left(\frac{L_s}{L_m} - 0.375 \right) \cdot \left(\frac{X_s}{L_m} + 0.3125 \right) \dots \\
 & + 367400 \left(\frac{X_s}{L_m} + 0.3125 \right)^2 \cdot (L_m - 180) + -4038000000 \left(\frac{L_s}{L_m} - 0.375 \right)^3 \dots \\
 & + -2110000000 \left(\frac{L_s}{L_m} - 0.375 \right)^2 \cdot \left(\frac{X_s}{L_m} + 0.3125 \right) + 347900000 \left(\frac{X_s}{L_m} + 0.3125 \right)^3 \dots \\
 & + 0.04053(L_m - 180)^4 + 228.9(L_m - 180)^3 \cdot \left(\frac{L_s}{L_m} - 0.375 \right) \dots \\
 & + 26720(L_m - 180)^2 \cdot \left(\frac{L_s}{L_m} - 0.375 \right)^2 + -35500(L_m - 180)^2 \cdot \left(\frac{X_s}{L_m} + 0.3125 \right) \cdot \left(\frac{L_s}{L_m} - 0.375 \right) \dots \\
 & + -71960000 \left(\frac{L_s}{L_m} - 0.375 \right)^3 \cdot (L_m - 180) + -36190000 \left(\frac{L_s}{L_m} - 0.375 \right)^2 \cdot (L_m - 180) \cdot \left(\frac{X_s}{L_m} + 0.3125 \right) \dots \\
 & + 2871000 \left(\frac{X_s}{L_m} + 0.3125 \right)^3 \cdot (L_m - 180) + 3429000000 \left(\frac{L_s}{L_m} - 0.375 \right)^2 \cdot \left(\frac{X_s}{L_m} + 0.3125 \right)^2 \dots \\
 & + 3328000000 \left(\frac{X_s}{L_m} + 0.3125 \right)^3 \cdot \left(\frac{L_s}{L_m} - 0.375 \right) + -256800000 \left(\frac{X_s}{L_m} + 0.3125 \right)^4
 \end{aligned}$$

Actual by Predicted Plot Negative Twisting

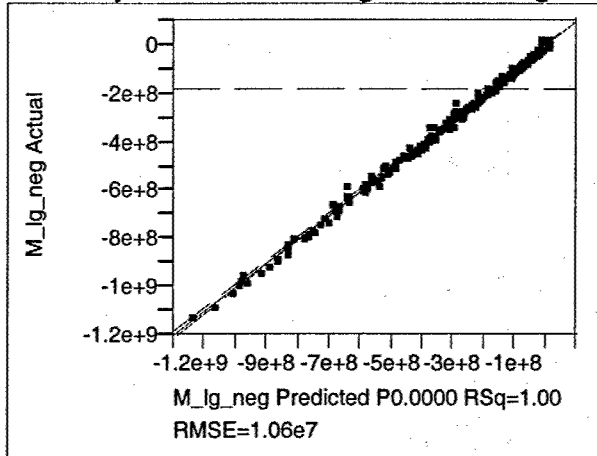

Summary of Fit Negative Twisting

RSquare	0.99804
RSquare Adj	0.99792
Root Mean Square Error	10575155
Mean of Response	-1.849e8
Observations (or Sum Wgts)	468

$$\begin{aligned}
 M_{\text{neg}} = & 470200000 + -1843000L_m + -549900000 \frac{L_s}{L_m} + 52640000 \frac{X_s}{L_m} + -15260(L_m - 180)^2 \dots \\
 & + -10820000 \left(\frac{L_s}{L_m} - 0.375 \right) \cdot (L_m - 180) + 741500 \left(\frac{X_s}{L_m} + 0.3125 \right) \cdot (L_m - 180) \dots \\
 & + 842000000 \left(\frac{L_s}{L_m} - 0.375 \right) \cdot \left(\frac{X_s}{L_m} + 0.3125 \right) + -430100000 \left(\frac{X_s}{L_m} + 0.3125 \right)^2 + -47.46(L_m - 180)^3 \dots \\
 & + -78110(L_m - 180)^2 \cdot \left(\frac{L_s}{L_m} - 0.375 \right) + -5926000 \left(\frac{L_s}{L_m} - 0.375 \right)^2 \cdot (L_m - 180) \dots \\
 & + 2805(L_m - 180)^2 \cdot \left(\frac{X_s}{L_m} + 0.3125 \right) + 7941000(L_m - 180) \cdot \left(\frac{L_s}{L_m} - 0.375 \right) \cdot \left(\frac{X_s}{L_m} + 0.3125 \right) \dots \\
 & + -3490000 \left(\frac{X_s}{L_m} + 0.3125 \right)^2 \cdot (L_m - 180) + 683300000 \left(\frac{L_s}{L_m} - 0.375 \right)^3 \dots \\
 & + -338275456 \left(\frac{X_s}{L_m} + 0.3125 \right)^3 + -224.6(L_m - 180)^3 \cdot \left(\frac{L_s}{L_m} - 0.375 \right) \dots \\
 & + 38050(L_m - 180)^2 \cdot \left(\frac{X_s}{L_m} + 0.3125 \right) \cdot \left(\frac{L_s}{L_m} - 0.375 \right) + -14060(L_m - 180)^2 \cdot \left(\frac{X_s}{L_m} + 0.3125 \right)^2 \dots \\
 & + 79630000 \left(\frac{L_s}{L_m} - 0.375 \right)^3 \cdot (L_m - 180) + 20870000 \left(\frac{L_s}{L_m} - 0.375 \right)^2 \cdot (L_m - 180) \cdot \left(\frac{X_s}{L_m} + 0.3125 \right) \dots \\
 & + -8802000 \left(\frac{L_s}{L_m} - 0.375 \right) \cdot (L_m - 180) \cdot \left(\frac{X_s}{L_m} + 0.3125 \right)^2 + -2796000 \left(\frac{X_s}{L_m} + 0.3125 \right)^3 \cdot (L_m - 180) \dots \\
 & + -3775000000 \left(\frac{L_s}{L_m} - 0.375 \right)^4 + 7867000000 \left(\frac{L_s}{L_m} - 0.375 \right)^2 \cdot \left(\frac{X_s}{L_m} + 0.3125 \right)^2 \dots \\
 & + -7595000000 \left(\frac{X_s}{L_m} + 0.3125 \right)^3 \cdot \left(\frac{L_s}{L_m} - 0.375 \right) + 2099000000 \left(\frac{X_s}{L_m} + 0.3125 \right)^4 \dots
 \end{aligned}$$

Actual by Predicted Plot Transverse Sagging

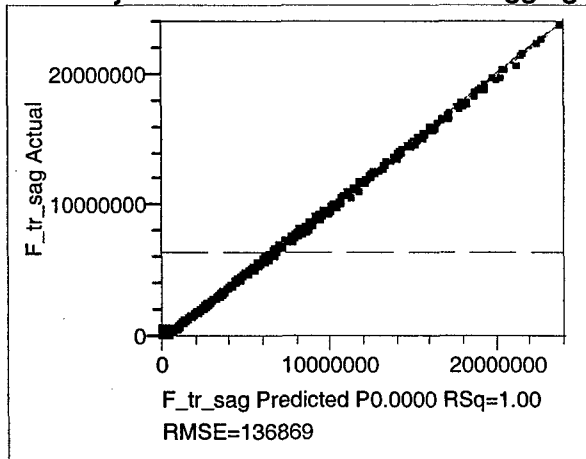

Summary of Fit Transverse Sagging

RSquare	0.999459
RSquare Adj	0.999435
Root Mean Square Error	136868.7
Mean of Response	6480962
Observations (or Sum Wgts)	468

$$\begin{aligned}
 F_{tr_sag} = & -7051000 + 951100B_m + -17730000 \frac{B_s}{B_m} + 3046000 \frac{Y_s}{B_m} + 55500(B_m - 12.86)^2 \dots \\
 & + -3537000 \left(\frac{B_s}{B_m} - 0.2357 \right) \cdot (B_m - 12.86) + 60540000 \left(\frac{B_s}{B_m} - 0.2357 \right)^2 \dots \\
 & + 592100(B_m - 12.86) \cdot \left(\frac{Y_s}{B_m} - 1.25 \right) + -10590000 \left(\frac{B_s}{B_m} - 0.2357 \right) \cdot \left(\frac{Y_s}{B_m} - 1.25 \right) \dots \\
 & + 1055(B_m - 12.86)^3 + -216600(B_m - 12.86)^2 \cdot \left(\frac{B_s}{B_m} - 0.2357 \right) + 12750000 \left(\frac{B_s}{B_m} - 0.2357 \right)^2 \cdot (B_m - 12.86) \dots \\
 & + 38890(B_m - 12.86)^2 \cdot \left(\frac{Y_s}{B_m} - 1.25 \right) + -2246000(B_m - 12.86) \cdot \left(\frac{B_s}{B_m} - 0.2357 \right) \cdot \left(\frac{Y_s}{B_m} - 1.25 \right) \dots \\
 & + -143000 \left(\frac{Y_s}{B_m} - 1.25 \right)^2 \cdot (B_m - 12.86) + 35.06(B_m - 12.86)^4 \dots \\
 & + -3806(B_m - 12.86)^3 \cdot \left(\frac{B_s}{B_m} - 0.2357 \right) + 740600(B_m - 12.86)^2 \cdot \left(\frac{B_s}{B_m} - 0.2357 \right)^2 \dots \\
 & + -135100(B_m - 12.86)^2 \cdot \left(\frac{B_s}{B_m} - 0.2357 \right) \cdot \left(\frac{Y_s}{B_m} - 1.25 \right) + 1063000 \left(\frac{Y_s}{B_m} - 1.25 \right)^3 \cdot (B_m - 12.86) \dots \\
 & + -17961988 \left(\frac{Y_s}{B_m} - 1.25 \right)^4
 \end{aligned}$$

Page Intentionally Left Blank

Appendix E. Comparison of Results for Longitudinal Troughing Analytical Troughing

INITIAL PANEL ADEQUACY PARAMETER VALUES - MODULE 1 OF SUBSTR. 1

STRAKE	PCSF	PCCB	PCMY	PCSB	PYTF	PYTP	PYCF	PYCP	PSPBT	PSPBL	PFLB
1	0.826	0.938	0.927	0.933	1.000	1.000	0.965	0.965	1.000	1.000	0.807
2	0.883	0.978	0.939	0.913	1.000	1.000	0.945	0.945	1.000	1.000	0.882
3	0.971	0.996	0.986	0.985	1.000	1.000	0.990	0.990	1.000	1.000	0.923
4	0.939	0.990	0.955	0.991	0.998	0.998	0.995	0.995	1.000	1.000	0.932
5	0.979	1.000	0.983	1.000	1.000	1.000	1.000	1.000	1.000	1.000	0.979
6	0.957	0.988	0.976	0.994	1.000	1.000	0.996	0.996	1.000	1.000	0.901
7	0.913	0.990	0.940	1.000	1.000	1.000	1.000	1.000	1.000	1.000	0.906

MAESTRO Troughing

INITIAL PANEL ADEQUACY PARAMETER VALUES - MODULE 1 OF SUBSTR. 1

STRAKE	PCSF	PCCB	PCMY	PCSB	PYTF	PYTP	PYCF	PYCP	PSPBT	PSPBL	PFLB
1	0.848	0.943	0.937	0.939	1.000	1.000	0.969	0.969	1.000	1.000	0.831
2	0.898	0.980	0.944	0.918	1.000	1.000	0.948	0.948	1.000	1.000	0.897
3	0.972	0.997	0.988	0.986	1.000	1.000	0.991	0.991	1.000	1.000	0.940
4	0.949	0.987	0.964	0.991	1.000	1.000	0.995	0.995	1.000	1.000	0.944
5	0.977	1.000	0.983	1.000	1.000	1.000	1.000	1.000	1.000	1.000	0.977
6	0.967	0.986	0.983	0.995	1.000	1.000	0.997	0.997	1.000	1.000	0.923
7	0.918	0.967	0.945	1.000	1.000	1.000	1.000	1.000	1.000	1.000	0.908

POSITIVE NUMBER: CONSTRAINT SATISFIED. | THESE VALUES ARE NORMALIZED
 NEGATIVE NUMBER: CONSTRAINT VIOLATED. | BETWEEN +1. AND -1.
 1.000 : CONSTRAINT NOT RELEVANT OR NULLIFIED BY USER.
 -2.000 : CONSTRAINT SUPPRESSED.

Analytical Troughing

INITIAL FRAME ADEQUACY PARAMETER VALUES - MODULE 1 OF SUBSTR. 1

STRAKE	FCPH1	FCPH2	FCPH3	FYCF1	FYCF2	FYCF3	FYTF1	FYTF2	FYTF3	FYCP1	FYCP2	FYCP3	FYTP1	FYTP2	FYTP3
1	0.896	0.842	0.965	0.862	1.000	1.000	1.000	0.772	0.939	1.000	0.955	0.977	0.956	1.000	1.000
2	0.784	0.964	0.898	0.714	1.000	0.864	1.000	0.933	1.000	1.000	0.980	1.000	0.935	1.000	0.969
3	0.840	0.851	0.993	0.755	1.000	0.974	1.000	0.760	1.000	1.000	0.960	1.000	0.953	1.000	0.974
4	0.939	0.939	0.992	1.000	0.901	0.985	0.899	1.000	0.977	0.974	1.000	0.978	1.000	0.975	1.000
5	0.975	0.985	0.982	0.961	0.977	0.969	1.000	1.000	1.000	1.000	1.000	1.000	0.983	0.984	0.984
6	0.842	0.852	0.994	1.000	0.767	1.000	0.753	1.000	0.973	0.953	1.000	0.974	1.000	0.958	1.000
7	0.878	0.882	0.981	0.793	1.000	0.871	1.000	0.798	1.000	1.000	0.869	0.871	0.870	1.000	0.884

MAESTRO Troughing

INITIAL FRAME ADEQUACY PARAMETER VALUES - MODULE 1 OF SUBSTR. 1

STRAKE	FCPH1	FCPH2	FCPH3	FYCF1	FYCF2	FYCF3	FYTF1	FYTF2	FYTF3	FYCP1	FYCP2	FYCP3	FYTP1	FYTP2	FYTP3
1	0.935	0.884	0.969	0.915	1.000	1.000	1.000	0.830	0.946	1.000	0.969	0.984	0.971	1.000	1.000
2	0.820	0.973	0.918	0.764	1.000	0.897	1.000	0.946	1.000	1.000	0.984	1.000	0.949	1.000	0.975
3	0.876	0.884	0.995	0.810	1.000	0.980	1.000	0.811	0.983	1.000	0.971	1.000	0.963	1.000	0.980
4	0.945	0.958	0.985	1.000	0.931	1.000	0.909	1.000	0.972	0.979	1.000	0.982	1.000	0.980	1.000
5	0.984	0.991	0.989	0.974	0.985	0.980	1.000	1.000	1.000	1.000	0.994	1.000	0.987	0.988	0.988
6	0.882	0.892	0.994	1.000	0.828	1.000	0.813	1.000	0.979	0.965	1.000	0.981	1.000	0.970	1.000
7	0.913	0.883	0.981	0.839	1.000	1.000	1.000	0.807	0.888	1.000	0.887	0.890	0.889	1.000	1.000

POSITIVE NUMBER: CONSTRAINT SATISFIED. | THESE VALUES ARE NORMALIZED
 NEGATIVE NUMBER: CONSTRAINT VIOLATED. | BETWEEN +1. AND -1.
 1.000 : CONSTRAINT NOT RELEVANT OR NULLIFIED BY USER.
 -2.000 : CONSTRAINT SUPPRESSED.
 -- : STRAKE NOT EVALUATED.

Analytical Troughing

INITIAL PANEL ADEQUACY PARAMETER VALUES - MODULE 2 OF SUBSTR. 1

STRAKE	PCSF	PCCB	PCMY	PCSB	PYTF	PYTP	PYCF	PYCP	PSPBT	PSPBL	PFLB
1	0.817	0.945	0.907	0.951	0.992	0.992	0.975	0.975	1.000	1.000	0.797
2	0.894	0.981	0.897	0.959	0.999	0.999	0.975	0.975	1.000	1.000	0.884
3	0.877	0.779	0.924	0.983	1.000	1.000	0.990	0.990	1.000	1.000	0.753
4	0.935	0.911	0.954	0.990	0.986	0.986	0.994	0.994	1.000	1.000	0.861
5	0.823	0.992	0.867	1.000	1.000	1.000	1.000	1.000	1.000	1.000	0.824
6	0.838	0.693	0.906	0.980	1.000	1.000	0.988	0.988	1.000	1.000	0.657
7	0.585	0.941	0.693	1.000	1.000	1.000	1.000	1.000	1.000	1.000	0.583

MAESTRO Troughing

INITIAL PANEL ADEQUACY PARAMETER VALUES - MODULE 2 OF SUBSTR. 1

STRAKE	PCSF	PCCB	PCMY	PCSB	PYTF	PYTP	PYCF	PYCP	PSPBT	PSPBL	PFLB
1	0.843	0.941	0.929	0.956	0.994	0.994	0.977	0.977	1.000	1.000	0.823
2	0.911	0.983	0.919	0.958	1.000	1.000	0.974	0.974	1.000	1.000	0.903
3	0.903	0.825	0.941	0.987	1.000	1.000	0.992	0.992	1.000	1.000	0.803
4	0.947	0.930	0.962	0.992	0.989	0.989	0.995	0.995	1.000	1.000	0.891
5	0.873	0.972	0.907	1.000	1.000	1.000	1.000	1.000	1.000	1.000	0.873
6	0.870	0.752	0.926	0.985	1.000	1.000	0.991	0.991	1.000	1.000	0.719
7	0.658	0.963	0.750	1.000	1.000	1.000	1.000	1.000	1.000	1.000	0.657

POSITIVE NUMBER: CONSTRAINT SATISFIED. | THESE VALUES ARE NORMALIZED
 NEGATIVE NUMBER: CONSTRAINT VIOLATED. | BETWEEN +1. AND -1.
 1.000 : CONSTRAINT NOT RELEVANT OR NULLIFIED BY USER.
 -2.000 : CONSTRAINT SUPPRESSED.
 -- : STRAKE NOT EVALUATED.

Analytical Troughing

INITIAL FRAME ADEQUACY PARAMETER VALUES - MODULE 2 OF SUBSTR. 1

STRAKE	FCPH1	FCPH2	FCPH3	FYCF1	FYCF2	FYCF3	FYTF1	FYTF2	FYTF3	FYCP1	FYCP2	FYCP3	FYTP1	FYTP2	FYTP3
1	0.964	0.982	0.985	0.963	1.000	0.989	1.000	0.971	1.000	0.995	0.988	0.992	0.977	0.989	0.983
2	0.932	0.932	0.997	0.897	1.000	1.000	0.985	0.886	0.937	1.000	0.981	0.992	0.925	0.937	0.931
3	0.890	0.900	0.994	0.829	0.986	0.937	1.000	0.843	1.000	0.945	0.933	0.939	0.972	1.000	0.984
4	0.988	0.976	0.986	0.975	0.976	0.976	0.984	0.967	0.980	0.976	0.976	0.976	1.000	1.000	1.000
5	0.962	0.987	0.981	0.961	0.971	0.968	0.942	0.899	0.924	0.986	0.985	0.986	0.878	0.891	0.884
6	0.888	0.896	0.993	0.982	0.833	0.938	0.829	1.000	0.984	0.918	0.929	0.923	1.000	0.976	1.000
7	0.892	0.918	0.974	0.820	1.000	0.896	0.853	0.787	0.819	0.929	0.897	0.923	0.830	0.840	0.835

MAESTRO Troughing

INITIAL FRAME ADEQUACY PARAMETER VALUES - MODULE 2 OF SUBSTR. 1

STRAKE	FCPH1	FCPH2	FCPH3	FYCF1	FYCF2	FYCF3	FYTF1	FYTF2	FYTF3	FYCP1	FYCP2	FYCP3	FYTP1	FYTP2	FYTP3
1	0.971	0.987	0.988	0.968	1.000	0.989	1.000	0.978	0.994	0.994	0.990	0.992	0.984	0.993	0.989
2	0.950	0.950	0.998	0.924	1.000	1.000	0.989	0.914	0.951	1.000	0.986	0.994	0.942	0.951	0.946
3	0.915	0.923	0.996	0.868	0.990	0.951	1.000	0.876	1.000	0.957	0.948	0.952	0.978	1.000	0.988
4	0.982	0.984	0.988	0.987	0.975	0.981	0.973	0.978	0.983	0.980	0.982	0.981	1.000	1.000	1.000
5	0.970	0.993	0.988	0.972	0.981	0.976	0.960	0.934	0.951	0.990	0.989	0.989	0.913	0.923	0.918
6	0.918	0.927	0.995	0.988	0.881	0.950	0.873	1.000	0.988	0.936	0.945	0.940	1.000	0.983	1.000
7	0.926	0.909	0.986	0.866	1.000	0.947	0.882	0.847	0.864	0.943	0.910	0.912	0.865	0.870	0.867

POSITIVE NUMBER: CONSTRAINT SATISFIED. | THESE VALUES ARE NORMALIZED
 NEGATIVE NUMBER: CONSTRAINT VIOLATED. | BETWEEN +1. AND -1.
 1.000 : CONSTRAINT NOT RELEVANT OR NULLIFIED BY USER.
 -2.000 : CONSTRAINT SUPPRESSED.
 -- : STRAKE NOT EVALUATED.

Analytical Troughing

INITIAL PANEL ADEQUACY PARAMETER VALUES - MODULE 1 OF SUBSTR. 2

STRAKE	PCSF	PCCB	PCMY	PCSB	PYTF	PYTP	PYCF	PYCP	PSPBT	PSPBL	PFLB
1	0.865	0.969	0.921	0.922	1.000	1.000	0.928	0.928	1.000	1.000	0.864
2	0.674	0.896	0.835	0.674	1.000	1.000	0.876	0.876	1.000	1.000	0.677
3	0.528	0.671	0.746	0.915	1.000	1.000	0.958	0.958	1.000	1.000	0.507
5	0.440	0.348	0.748	1.000	1.000	1.000	1.000	1.000	1.000	1.000	0.440
6	0.870	0.975	0.948	0.947	0.988	0.988	0.951	0.951	1.000	1.000	0.823

MAESTRO Troughing

INITIAL PANEL ADEQUACY PARAMETER VALUES - MODULE 1 OF SUBSTR. 2

STRAKE	PCSF	PCCB	PCMY	PCSB	PYTF	PYTP	PYCF	PYCP	PSPBT	PSPBL	PFLB
1	0.897	0.976	0.931	0.941	0.999	0.999	0.945	0.945	1.000	1.000	0.839
2	0.717	0.929	0.870	0.769	1.000	1.000	0.915	0.915	1.000	1.000	0.720
3	0.557	0.759	0.761	0.985	0.995	0.995	0.993	0.993	1.000	1.000	0.541
5	0.462	0.377	0.762	1.000	1.000	1.000	1.000	1.000	1.000	1.000	0.463
6	0.890	0.985	0.952	0.958	0.986	0.986	0.961	0.961	1.000	1.000	0.859

POSITIVE NUMBER: CONSTRAINT SATISFIED. | THESE VALUES ARE NORMALIZED
 NEGATIVE NUMBER: CONSTRAINT VIOLATED. | BETWEEN +1. AND -1.
 1.000 : CONSTRAINT NOT RELEVANT OR NULLIFIED BY USER.
 -2.000 : CONSTRAINT SUPPRESSED.
 -- : STRAKE NOT EVALUATED.

Analytical Troughing

INITIAL FRAME ADEQUACY PARAMETER VALUES - MODULE 1 OF SUBSTR. 2

STRAKE	FCPH1	FCPH2	FCPH3	FYCF1	FYCF2	FYCF3	FYTF1	FYTF2	FYTF3	FYCP1	FYCP2	FYCP3	FYTP1	FYTP2	FYTP3
1	0.837	0.813	0.986	1.000	0.650	0.837	0.736	1.000	1.000	0.843	1.000	0.848	1.000	0.846	1.000
2	0.757	0.785	0.976	0.660	1.000	1.000	1.000	0.556	0.786	1.000	1.000	1.000	0.767	0.798	0.786
3	0.916	0.918	0.948	0.974	0.893	0.968	0.921	0.930	0.974	0.968	1.000	0.977	0.865	0.899	0.882
5	0.929	0.982	0.955	0.919	0.954	0.937	0.851	0.857	0.854	0.957	0.952	0.955	0.872	0.870	0.871
6	0.837	0.801	0.979	0.695	1.000	0.939	1.000	0.671	0.842	0.983	0.839	0.940	0.839	1.000	0.843

MAESTRO Troughing

INITIAL FRAME ADEQUACY PARAMETER VALUES - MODULE 1 OF SUBSTR. 2

STRAKE	FCPH1	FCPH2	FCPH3	FYCF1	FYCF2	FYCF3	FYTF1	FYTF2	FYTF3	FYCP1	FYCP2	FYCP3	FYTP1	FYTP2	FYTP3
1	0.865	0.841	0.986	1.000	0.693	0.859	0.784	1.000	1.000	0.868	0.990	0.872	1.000	0.871	1.000
2	0.790	0.819	0.976	0.706	1.000	1.000	1.000	0.614	0.818	1.000	1.000	1.000	0.793	0.824	0.811
3	0.943	0.923	0.964	1.000	0.894	0.965	0.931	0.942	0.970	0.973	1.000	0.980	0.894	0.916	0.905
5	0.929	0.987	0.958	0.916	0.954	0.934	0.890	0.873	0.881	0.958	0.953	0.956	0.873	0.881	0.877
6	0.864	0.829	0.980	0.736	1.000	0.947	1.000	0.719	0.866	0.983	0.864	0.950	0.863	1.000	0.867

POSITIVE NUMBER: CONSTRAINT SATISFIED. | THESE VALUES ARE NORMALIZED
 NEGATIVE NUMBER: CONSTRAINT VIOLATED. | BETWEEN +1. AND -1.
 1.000 : CONSTRAINT NOT RELEVANT OR NULLIFIED BY USER.
 -2.000 : CONSTRAINT SUPPRESSED.
 -- : STRAKE NOT EVALUATED.

Analytical Troughing

INITIAL PANEL ADEQUACY PARAMETER VALUES - MODULE 2 OF SUBSTR. 2

STRAKE	PCSF	PCCB	PCMY	PCSB	PYTF	PYTP	PYCF	PYCP	PSPBT	PSPBL	PFLB
1	0.716	0.873	0.864	0.897	1.000	1.000	0.946	0.946	1.000	1.000	0.701
2	0.800	0.952	0.871	0.828	1.000	1.000	0.888	0.888	1.000	1.000	0.801
3	0.950	0.979	0.984	0.982	0.999	0.999	0.989	0.989	1.000	1.000	0.924
4	0.963	0.981	0.970	0.985	0.987	0.987	0.995	0.995	1.000	1.000	0.958
5	0.890	0.959	0.897	1.000	1.000	1.000	1.000	1.000	1.000	1.000	0.888
6	0.953	0.983	0.964	0.997	0.982	0.982	1.000	1.000	1.000	1.000	0.873
7	0.814	0.956	0.856	1.000	1.000	1.000	1.000	1.000	1.000	1.000	0.815

MAESTRO Troughing

INITIAL PANEL ADEQUACY PARAMETER VALUES - MODULE 2 OF SUBSTR. 2

STRAKE	PCSF	PCCB	PCMY	PCSB	PYTF	PYTP	PYCF	PYCP	PSPBT	PSPBL	PFLB
1	0.743	0.880	0.874	0.921	1.000	1.000	0.959	0.959	1.000	1.000	0.730
2	0.832	0.960	0.907	0.875	1.000	1.000	0.921	0.921	1.000	1.000	0.833
3	0.964	0.998	0.981	0.992	0.990	0.990	0.995	0.995	1.000	1.000	0.922
4	0.971	1.000	0.968	1.000	0.982	0.982	1.000	1.000	1.000	1.000	0.961
5	0.903	0.946	0.905	1.000	1.000	1.000	1.000	1.000	1.000	1.000	0.902
6	0.965	1.000	0.964	0.998	0.978	0.978	1.000	1.000	1.000	1.000	0.888
7	0.822	0.948	0.864	1.000	1.000	1.000	1.000	1.000	1.000	1.000	0.823

POSITIVE NUMBER: CONSTRAINT SATISFIED. | THESE VALUES ARE NORMALIZED
 NEGATIVE NUMBER: CONSTRAINT VIOLATED. | BETWEEN +1. AND -1.
 1.000 : CONSTRAINT NOT RELEVANT OR NULLIFIED BY USER.
 -2.000 : CONSTRAINT SUPPRESSED.
 -- : STRAKE NOT EVALUATED.

Analytical Troughing

INITIAL FRAME ADEQUACY PARAMETER VALUES - MODULE 2 OF SUBSTR. 2

STRAKE	FCPH1	FCPH2	FCPH3	FYCF1	FYCF2	FYCF3	FYTF1	FYTF2	FYTF3	FYCP1	FYCP2	FYCP3	FYTP1	FYTP2	FYTP3
1	0.950	0.981	0.968	0.941	0.989	0.965	0.969	0.944	0.957	0.987	0.980	0.983	0.962	0.978	0.972
2	0.871	0.883	0.986	0.825	1.000	1.000	1.000	0.799	0.966	1.000	0.972	0.987	0.942	1.000	0.972
3	0.835	0.842	0.994	0.777	1.000	0.978	1.000	0.774	0.976	1.000	0.956	0.985	0.939	1.000	0.974
4	0.879	0.919	0.971	1.000	0.639	1.000	0.624	1.000	0.652	0.652	1.000	0.653	1.000	0.653	0.961
5	0.972	0.977	0.975	0.957	0.964	0.961	0.973	0.953	0.964	0.990	0.990	0.990	0.932	0.938	0.935
6	0.828	0.832	0.994	1.000	0.762	0.975	0.765	1.000	0.978	0.940	1.000	0.975	1.000	0.949	1.000
7	0.918	0.918	0.946	0.854	1.000	0.911	0.969	0.860	0.932	0.967	0.907	0.911	0.911	1.000	0.942

MAESTRO Troughing

INITIAL FRAME ADEQUACY PARAMETER VALUES - MODULE 2 OF SUBSTR. 2

STRAKE	FCPH1	FCPH2	FCPH3	FYCF1	FYCF2	FYCF3	FYTF1	FYTF2	FYTF3	FYCP1	FYCP2	FYCP3	FYTP1	FYTP2	FYTP3
1	0.969	0.984	0.979	0.962	0.990	0.976	0.972	0.952	0.962	0.986	0.982	0.984	0.976	0.981	0.978
2	0.885	0.908	0.986	0.838	1.000	1.000	1.000	0.828	0.975	1.000	0.976	0.988	0.956	1.000	0.978
3	0.866	0.870	0.996	0.817	1.000	0.982	1.000	0.814	0.981	1.000	0.963	0.985	0.952	1.000	0.980
4	0.891	0.925	0.976	1.000	0.662	1.000	0.646	1.000	0.673	0.673	1.000	0.674	1.000	0.674	0.964
5	0.984	0.984	0.984	0.968	0.968	0.968	0.978	0.962	0.971	0.987	0.988	0.988	0.942	0.947	0.945
6	0.862	0.865	0.995	1.000	0.807	0.980	0.812	1.000	0.983	0.950	0.992	0.979	1.000	0.962	1.000
7	0.944	0.918	0.951	0.890	1.000	0.958	0.966	0.869	0.925	0.979	0.921	0.925	0.926	1.000	0.958

POSITIVE NUMBER: CONSTRAINT SATISFIED. | THESE VALUES ARE NORMALIZED
 NEGATIVE NUMBER: CONSTRAINT VIOLATED. | BETWEEN +1. AND -1.
 1.000 : CONSTRAINT NOT RELEVANT OR NULLIFIED BY USER.
 -2.000 : CONSTRAINT SUPPRESSED.
 -- : STRAKE NOT EVALUATED.

Analytical Troughing

INITIAL PANEL ADEQUACY PARAMETER VALUES - MODULE 3 OF SUBSTR. 2

STRAKE	PCSF	PCCB	PCMY	PCSB	PYTF	PYTP	PYCF	PYCP	PSPBT	PSPBL	PFLB
1	0.782	0.919	0.943	0.900	1.000	1.000	0.948	0.948	1.000	1.000	0.775
2	0.836	0.956	0.910	0.862	1.000	1.000	0.910	0.910	1.000	1.000	0.836
3	0.964	0.995	0.981	0.978	1.000	1.000	0.986	0.986	1.000	1.000	0.922
4	0.949	0.990	0.969	0.981	1.000	1.000	0.988	0.988	1.000	1.000	0.939
5	0.967	0.996	0.977	1.000	1.000	1.000	1.000	1.000	1.000	1.000	0.965
6	0.968	0.984	0.982	0.992	1.000	1.000	0.995	0.995	1.000	1.000	0.893
7	0.929	0.947	0.958	1.000	1.000	1.000	1.000	1.000	1.000	1.000	0.904

MAESTRO Troughing

INITIAL PANEL ADEQUACY PARAMETER VALUES - MODULE 3 OF SUBSTR. 2

STRAKE	PCSF	PCCB	PCMY	PCSB	PYTF	PYTP	PYCF	PYCP	PSPBT	PSPBL	PFLB
1	0.819	0.920	0.954	0.921	1.000	1.000	0.959	0.959	1.000	1.000	0.811
2	0.867	0.962	0.931	0.892	1.000	1.000	0.930	0.930	1.000	1.000	0.865
3	0.970	0.996	0.985	0.982	1.000	1.000	0.989	0.989	1.000	1.000	0.939
4	0.962	0.986	0.978	0.986	1.000	1.000	0.992	0.992	1.000	1.000	0.953
5	0.965	0.986	0.978	1.000	1.000	1.000	1.000	1.000	1.000	1.000	0.965
6	0.970	0.984	0.990	0.994	0.998	0.998	0.997	0.997	1.000	1.000	0.907
7	0.939	0.933	0.967	1.000	1.000	1.000	1.000	1.000	1.000	1.000	0.904

POSITIVE NUMBER: CONSTRAINT SATISFIED. | THESE VALUES ARE NORMALIZED
 NEGATIVE NUMBER: CONSTRAINT VIOLATED. | BETWEEN +1. AND -1.
 1.000 : CONSTRAINT NOT RELEVANT OR NULLIFIED BY USER.
 -2.000 : CONSTRAINT SUPPRESSED.
 --- : STRAKE NOT EVALUATED.

Analytical Troughing

INITIAL FRAME ADEQUACY PARAMETER VALUES - MODULE 3 OF SUBSTR. 2

STRAKE	FCPH1	FCPH2	FCPH3	FYCF1	FYCF2	FYCF3	FYTF1	FYTF2	FYTF3	FYCP1	FYCP2	FYCP3	FYTP1	FYTP2	FYTP3
1	0.914	0.921	0.983	0.897	1.000	0.986	1.000	0.878	0.964	1.000	0.977	0.987	0.959	1.000	0.979
2	0.891	0.900	0.985	0.857	1.000	0.989	1.000	0.850	0.987	1.000	0.978	0.990	0.956	1.000	0.983
3	0.814	0.822	0.994	0.748	1.000	0.974	1.000	0.748	0.973	1.000	0.948	1.000	0.933	1.000	0.972
4	0.907	0.864	0.976	1.000	0.811	0.953	0.862	1.000	0.965	0.957	1.000	0.968	1.000	0.944	0.962
5	0.978	0.983	0.984	0.963	0.977	0.970	1.000	1.000	1.000	0.994	0.986	0.994	0.985	0.985	0.986
6	0.811	0.816	0.993	1.000	0.746	1.000	0.739	1.000	0.972	0.938	1.000	0.973	1.000	0.939	1.000
7	0.888	0.875	0.985	0.803	1.000	0.921	1.000	0.792	0.874	1.000	0.871	0.874	0.873	1.000	0.923

MAESTRO Troughing

INITIAL FRAME ADEQUACY PARAMETER VALUES - MODULE 3 OF SUBSTR. 2

STRAKE	FCPH1	FCPH2	FCPH3	FYCF1	FYCF2	FYCF3	FYTF1	FYTF2	FYTF3	FYCP1	FYCP2	FYCP3	FYTP1	FYTP2	FYTP3
1	0.946	0.940	0.980	0.937	1.000	0.992	1.000	0.908	0.963	0.993	0.982	0.989	0.973	1.000	0.985
2	0.911	0.921	0.986	0.885	1.000	0.989	1.000	0.878	0.991	1.000	0.983	0.992	0.963	1.000	0.985
3	0.856	0.860	0.996	0.804	1.000	0.980	1.000	0.800	0.979	1.000	0.960	1.000	0.948	1.000	0.978
4	0.916	0.891	0.979	1.000	0.848	0.965	0.876	1.000	0.960	0.963	1.000	0.975	1.000	0.954	0.968
5	0.986	0.988	0.989	0.975	0.985	0.980	1.000	1.000	1.000	0.995	0.989	0.995	0.989	0.990	0.989
6	0.856	0.861	0.993	1.000	0.806	1.000	0.799	1.000	0.979	0.954	1.000	0.980	1.000	0.955	1.000
7	0.919	0.873	0.973	0.844	1.000	1.000	1.000	0.798	0.885	1.000	0.886	0.889	0.889	1.000	0.944

POSITIVE NUMBER: CONSTRAINT SATISFIED. | THESE VALUES ARE NORMALIZED
 NEGATIVE NUMBER: CONSTRAINT VIOLATED. | BETWEEN +1. AND -1.
 1.000 : CONSTRAINT NOT RELEVANT OR NULLIFIED BY USER.
 -2.000 : CONSTRAINT SUPPRESSED.
 -- : STRAKE NOT EVALUATED.

Appendix F. Comparison of Results for Longitudinal Cresting Analytical Cresting

INITIAL PANEL ADEQUACY PARAMETER VALUES - MODULE 1 OF SUBSTR. 1

STRAKE	PCSF	PCCB	PCMY	PCSB	PYTF	PYTP	PYCF	PYCP	PSPBT	PSPBL	PFLB
1	0.858	0.934	0.944	0.943	1.000	1.000	0.971	0.971	1.000	1.000	0.841
2	0.917	0.982	0.951	0.926	1.000	1.000	0.953	0.953	1.000	1.000	0.915
3	0.974	0.997	0.988	0.987	1.000	1.000	0.992	0.992	1.000	1.000	0.972
4	0.953	0.983	0.970	0.986	1.000	1.000	0.992	0.992	1.000	1.000	0.936
5	0.950	0.931	0.983	1.000	1.000	1.000	1.000	1.000	1.000	1.000	0.950
6	0.967	0.982	0.980	0.992	1.000	1.000	0.995	0.995	1.000	1.000	0.952
7	0.928	0.950	0.961	1.000	1.000	1.000	1.000	1.000	1.000	1.000	0.922

MAESTRO Cresting

INITIAL PANEL ADEQUACY PARAMETER VALUES - MODULE 1 OF SUBSTR. 1

STRAKE	PCSF	PCCB	PCMY	PCSB	PYTF	PYTP	PYCF	PYCP	PSPBT	PSPBL	PFLB
1	0.834	0.970	0.925	0.947	1.000	1.000	0.973	0.973	1.000	1.000	0.825
2	0.902	0.979	0.945	0.916	1.000	1.000	0.947	0.947	1.000	1.000	0.901
3	0.969	0.986	0.980	0.986	1.000	1.000	0.991	0.991	1.000	1.000	0.961
4	0.942	0.998	0.958	0.991	0.999	0.999	0.995	0.995	1.000	1.000	0.942
5	0.966	0.968	0.987	1.000	1.000	1.000	1.000	1.000	1.000	1.000	0.966
6	0.957	0.999	0.969	0.997	1.000	1.000	0.998	0.998	1.000	1.000	0.949
7	0.913	0.988	0.937	1.000	1.000	1.000	1.000	1.000	1.000	1.000	0.913

POSITIVE NUMBER: CONSTRAINT SATISFIED. | THESE VALUES ARE NORMALIZED
 NEGATIVE NUMBER: CONSTRAINT VIOLATED. | BETWEEN +1. AND -1.
 1.000 : CONSTRAINT NOT RELEVANT OR NULLIFIED BY USER.
 -2.000 : CONSTRAINT SUPPRESSED.

Analytical Cresting

INITIAL FRAME ADEQUACY PARAMETER VALUES - MODULE 1 OF SUBSTR. 1

STRAKE	FCPH1	FCPH2	FCPH3	FYCF1	FYCF2	FYCF3	FYTF1	FYTF2	FYTF3	FYCP1	FYCP2	FYCP3	FYTP1	FYTP2	FYTP3
1	0.979	0.948	0.981	0.974	1.000	1.000	1.000	0.922	0.968	0.994	0.984	0.990	0.993	1.000	1.000
2	0.895	0.987	0.952	0.868	1.000	0.948	1.000	0.963	1.000	1.000	0.992	1.000	0.972	0.996	0.985
3	0.958	0.965	0.996	0.936	1.000	0.994	1.000	0.938	1.000	1.000	0.993	1.000	0.987	1.000	0.993
4	0.962	0.925	0.980	0.936	1.000	1.000	1.000	0.878	0.961	1.000	0.974	0.978	0.977	1.000	1.000
5	0.988	0.992	0.990	1.000	1.000	1.000	0.986	0.991	0.988	0.988	0.991	0.989	1.000	1.000	1.000
6	0.960	0.970	0.995	1.000	0.949	1.000	0.937	1.000	0.991	0.987	1.000	0.993	1.000	0.993	1.000
7	0.924	0.904	0.988	0.862	1.000	1.000	1.000	0.842	0.907	1.000	0.906	0.908	0.908	1.000	1.000

MAESTRO Cresting

INITIAL FRAME ADEQUACY PARAMETER VALUES - MODULE 1 OF SUBSTR. 1

STRAKE	FCPH1	FCPH2	FCPH3	FYCF1	FYCF2	FYCF3	FYTF1	FYTF2	FYTF3	FYCP1	FYCP2	FYCP3	FYTP1	FYTP2	FYTP3
1	0.812	0.860	0.972	0.742	1.000	0.953	1.000	0.802	1.000	1.000	0.955	0.972	0.956	1.000	0.987
2	0.871	0.970	0.947	0.837	1.000	0.944	1.000	0.937	1.000	1.000	0.988	1.000	0.966	1.000	0.983
3	0.956	0.962	0.994	0.928	1.000	0.990	1.000	0.939	1.000	1.000	0.988	0.993	0.990	1.000	0.996
4	0.932	0.868	0.930	0.902	0.791	0.884	1.000	0.951	1.000	0.975	0.980	1.000	0.975	0.964	0.973
5	0.950	0.971	0.960	0.921	0.947	0.934	1.000	1.000	1.000	0.989	0.976	0.976	0.976	0.997	0.979
6	0.931	0.909	0.988	1.000	0.857	0.979	0.886	1.000	1.000	0.984	1.000	0.994	1.000	0.973	0.985
7	0.903	0.805	0.873	0.865	0.721	0.806	1.000	1.000	1.000	1.000	1.000	1.000	0.916	0.908	0.913

POSITIVE NUMBER: CONSTRAINT SATISFIED. | THESE VALUES ARE NORMALIZED
 NEGATIVE NUMBER: CONSTRAINT VIOLATED. | BETWEEN +1. AND -1.
 1.000 : CONSTRAINT NOT RELEVANT OR NULLIFIED BY USER.
 -2.000 : CONSTRAINT SUPPRESSED.
 -- : STRAKE NOT EVALUATED.

Analytical Cresting

INITIAL PANEL ADEQUACY PARAMETER VALUES - MODULE 2 OF SUBSTR. 1

STRAKE	PCSF	PCCB	PCMY	PCSB	PYTF	PYTP	PYCF	PYCP	PSPBT	PSPBL	PFLB
1	0.899	0.952	0.957	0.971	0.996	0.996	0.985	0.985	1.000	1.000	0.884
2	0.950	0.991	0.960	0.969	1.000	1.000	0.981	0.981	1.000	1.000	0.947
3	0.947	0.897	0.970	0.994	1.000	1.000	0.997	0.997	1.000	1.000	0.887
4	0.962	0.965	0.973	0.999	0.992	0.992	0.999	0.999	1.000	1.000	0.945
5	0.928	0.956	0.947	1.000	1.000	1.000	1.000	1.000	1.000	1.000	0.929
6	0.924	0.846	0.955	0.989	1.000	1.000	0.993	0.993	1.000	1.000	0.819
7	0.934	0.931	0.963	1.000	1.000	1.000	1.000	1.000	1.000	1.000	0.926

MAESTRO Cresting

INITIAL PANEL ADEQUACY PARAMETER VALUES - MODULE 2 OF SUBSTR. 1

STRAKE	PCSF	PCCB	PCMY	PCSB	PYTF	PYTP	PYCF	PYCP	PSPBT	PSPBL	PFLB
1	0.881	0.975	0.935	0.971	0.993	0.993	0.985	0.985	1.000	1.000	0.877
2	0.945	0.991	0.949	0.971	1.000	1.000	0.982	0.982	1.000	1.000	0.942
3	0.936	0.871	0.962	0.994	1.000	1.000	0.996	0.996	1.000	1.000	0.860
4	0.951	0.955	0.971	0.999	0.988	0.988	1.000	1.000	1.000	1.000	0.920
5	0.861	0.981	0.895	1.000	1.000	1.000	1.000	1.000	1.000	1.000	0.861
6	0.909	0.805	0.943	0.985	1.000	1.000	0.991	0.991	1.000	1.000	0.777
7	0.846	0.777	0.940	1.000	1.000	1.000	1.000	1.000	1.000	1.000	0.846

POSITIVE NUMBER: CONSTRAINT SATISFIED. | THESE VALUES ARE NORMALIZED
 NEGATIVE NUMBER: CONSTRAINT VIOLATED. | BETWEEN +1. AND -1.
 1.000 : CONSTRAINT NOT RELEVANT OR NULLIFIED BY USER.
 -2.000 : CONSTRAINT SUPPRESSED.
 -- : STRAKE NOT EVALUATED.

Analytical Cresting

INITIAL FRAME ADEQUACY PARAMETER VALUES - MODULE 2 OF SUBSTR. 1

STRAKE	FCPH1	FCPH2	FCPH3	FYCF1	FYCF2	FYCF3	FYTF1	FYTF2	FYTF3	FYCP1	FYCP2	FYCP3	FYTP1	FYTP2	FYTP3
1	0.986	0.994	0.994	0.985	1.000	1.000	0.995	0.992	0.994	0.994	0.994	0.994	0.993	0.997	0.995
2	0.977	0.978	0.998	0.967	1.000	1.000	0.995	0.959	0.977	1.000	0.994	0.997	0.972	0.977	0.974
3	0.973	0.980	0.997	0.958	0.981	0.971	1.000	0.966	1.000	0.975	0.972	0.973	0.992	1.000	0.996
4	0.967	0.946	0.989	0.944	1.000	0.991	1.000	0.914	0.976	0.990	0.979	0.982	0.982	1.000	1.000
5	0.987	0.991	0.989	0.994	0.995	0.995	0.986	0.976	0.981	0.990	0.991	0.991	0.958	0.961	0.960
6	0.976	0.985	0.995	0.984	0.951	0.968	0.964	1.000	0.995	0.962	0.966	0.964	1.000	0.997	1.000
7	0.939	0.918	0.988	0.885	0.997	0.959	1.000	0.866	0.922	0.959	0.921	0.923	0.923	0.981	0.981

MAESTRO Cresting

INITIAL FRAME ADEQUACY PARAMETER VALUES - MODULE 2 OF SUBSTR. 1

STRAKE	FCPH1	FCPH2	FCPH3	FYCF1	FYCF2	FYCF3	FYTF1	FYTF2	FYTF3	FYCP1	FYCP2	FYCP3	FYTP1	FYTP2	FYTP3
1	0.963	0.991	0.986	0.951	1.000	1.000	1.000	0.985	0.996	1.000	0.990	0.995	0.984	0.991	0.987
2	0.968	0.968	0.998	0.953	1.000	1.000	0.994	0.942	0.971	1.000	0.992	0.996	0.964	0.970	0.967
3	0.975	0.986	0.994	0.954	0.969	0.962	1.000	0.978	1.000	0.967	0.965	0.966	0.995	1.000	0.997
4	0.922	0.900	0.988	0.871	1.000	0.982	1.000	0.842	0.961	0.983	0.958	0.965	0.962	1.000	1.000
5	0.980	0.991	0.986	0.967	0.980	0.974	0.952	0.933	0.943	0.997	0.988	0.997	0.917	0.922	0.920
6	0.965	0.966	0.997	0.972	0.943	0.959	0.947	1.000	0.997	0.951	0.954	0.952	1.000	0.993	1.000
7	0.888	0.953	0.949	0.829	1.000	0.900	1.000	0.904	1.000	0.971	0.923	0.969	0.922	1.000	0.923

POSITIVE NUMBER: CONSTRAINT SATISFIED. | THESE VALUES ARE NORMALIZED
 NEGATIVE NUMBER: CONSTRAINT VIOLATED. | BETWEEN +1. AND -1.
 1.000 : CONSTRAINT NOT RELEVANT OR NULLIFIED BY USER.
 -2.000 : CONSTRAINT SUPPRESSED.
 -- : STRAKE NOT EVALUATED.

Analytical Cresting

INITIAL PANEL ADEQUACY PARAMETER VALUES - MODULE 1 OF SUBSTR. 2

STRAKE	PCSF	PCCB	PCMY	PCSB	PYTF	PYTP	PYCF	PYCP	PSPBT	PSPBL	PFLB
1	0.908	0.983	0.955	0.952	1.000	1.000	0.956	0.956	1.000	1.000	0.907
2	0.657	0.900	0.856	0.692	1.000	1.000	0.881	0.881	1.000	1.000	0.654
3	0.648	0.716	0.848	0.869	1.000	1.000	0.935	0.935	1.000	1.000	0.613
5	0.651	0.575	0.853	1.000	1.000	1.000	1.000	1.000	1.000	1.000	0.651
6	0.913	0.984	0.977	0.975	0.990	0.990	0.977	0.977	1.000	1.000	0.882

MAESTRO Cresting

INITIAL PANEL ADEQUACY PARAMETER VALUES - MODULE 1 OF SUBSTR. 2

STRAKE	PCSF	PCCB	PCMY	PCSB	PYTF	PYTP	PYCF	PYCP	PSPBT	PSPBL	PFLB
1	0.866	0.976	0.941	0.937	1.000	1.000	0.942	0.942	1.000	1.000	0.863
2	0.503	0.855	0.775	0.585	1.000	1.000	0.817	0.817	1.000	1.000	0.500
3	0.514	0.627	0.840	0.772	1.000	1.000	0.883	0.883	1.000	1.000	0.471
5	0.676	0.594	0.857	1.000	1.000	1.000	1.000	1.000	1.000	1.000	0.676
6	0.893	0.972	0.973	0.970	0.992	0.992	0.973	0.973	1.000	1.000	0.850

POSITIVE NUMBER: CONSTRAINT SATISFIED. | THESE VALUES ARE NORMALIZED
 NEGATIVE NUMBER: CONSTRAINT VIOLATED. | BETWEEN +1. AND -1.
 1.000 : CONSTRAINT NOT RELEVANT OR NULLIFIED BY USER.
 -2.000 : CONSTRAINT SUPPRESSED.
 -- : STRAKE NOT EVALUATED.

Analytical Cresting

INITIAL FRAME ADEQUACY PARAMETER VALUES - MODULE 1 OF SUBSTR. 2

STRAKE	FCPH1	FCPH2	FCPH3	FYCF1	FYCF2	FYCF3	FYTF1	FYTF2	FYTF3	FYCP1	FYCP2	FYCP3	FYTP1	FYTP2	FYTP3
1	0.904	0.890	0.992	1.000	0.790	0.906	0.835	1.000	1.000	0.907	1.000	0.911	1.000	0.909	0.994
2	0.853	0.881	0.978	0.787	1.000	1.000	1.000	0.736	0.880	1.000	1.000	1.000	0.874	0.885	0.882
3	0.913	0.963	0.948	0.947	0.957	0.988	0.948	0.952	0.984	0.979	0.990	0.985	0.886	0.923	0.904
5	0.950	0.988	0.974	0.964	0.978	0.971	0.847	0.901	0.875	0.978	0.975	0.977	0.923	0.903	0.913
6	0.902	0.886	0.991	0.814	1.000	0.967	1.000	0.801	0.908	0.989	0.905	0.908	0.906	1.000	1.000

MAESTRO Cresting

INITIAL FRAME ADEQUACY PARAMETER VALUES - MODULE 1 OF SUBSTR. 2

STRAKE	FCPH1	FCPH2	FCPH3	FYCF1	FYCF2	FYCF3	FYTF1	FYTF2	FYTF3	FYCP1	FYCP2	FYCP3	FYTP1	FYTP2	FYTP3
1	0.893	0.882	0.992	1.000	0.782	0.901	0.812	1.000	0.988	0.899	1.000	0.903	0.988	0.901	0.984
2	0.839	0.871	0.977	0.767	1.000	1.000	1.000	0.715	0.869	1.000	0.872	1.000	0.869	0.961	0.874
3	0.878	0.970	0.926	0.911	0.974	0.974	0.942	0.946	0.974	0.974	0.986	0.980	0.854	0.906	0.880
5	0.913	0.985	0.956	0.972	0.981	0.978	0.790	0.875	0.834	0.982	0.979	0.980	0.899	0.874	0.888
6	0.893	0.882	0.994	0.806	1.000	0.966	1.000	0.788	0.902	0.990	0.899	0.903	0.901	1.000	1.000

POSITIVE NUMBER: CONSTRAINT SATISFIED. | THESE VALUES ARE NORMALIZED
 NEGATIVE NUMBER: CONSTRAINT VIOLATED. | BETWEEN +1. AND -1.
 1.000 : CONSTRAINT NOT RELEVANT OR NULLIFIED BY USER.
 -2.000 : CONSTRAINT SUPPRESSED.
 -- : STRAKE NOT EVALUATED.

Analytical Cresting

INITIAL PANEL ADEQUACY PARAMETER VALUES - MODULE 2 OF SUBSTR. 2

STRAKE	PCSF	PCCB	PCMY	PCSB	PYTF	PYTP	PYCF	PYCP	PSPBT	PSPBL	PFLB
1	0.773	0.869	0.940	0.907	1.000	1.000	0.952	0.952	1.000	1.000	0.756
2	0.801	0.959	0.878	0.839	1.000	1.000	0.894	0.894	1.000	1.000	0.795
3	0.957	0.995	0.981	0.978	1.000	1.000	0.986	0.986	1.000	1.000	0.954
4	0.936	0.990	0.971	0.961	1.000	1.000	0.986	0.986	1.000	1.000	0.938
5	0.934	0.898	0.946	1.000	1.000	1.000	1.000	1.000	1.000	1.000	0.934
6	0.960	0.980	0.975	0.992	0.991	0.991	0.995	0.995	1.000	1.000	0.925
7	0.910	0.923	0.926	1.000	1.000	1.000	1.000	1.000	1.000	1.000	0.911

MAESTRO Cresting

INITIAL PANEL ADEQUACY PARAMETER VALUES - MODULE 2 OF SUBSTR. 2

STRAKE	PCSF	PCCB	PCMY	PCSB	PYTF	PYTP	PYCF	PYCP	PSPBT	PSPBL	PFLB
1	0.718	0.870	0.915	0.876	1.000	1.000	0.935	0.935	1.000	1.000	0.696
2	0.703	0.941	0.830	0.778	1.000	1.000	0.853	0.853	1.000	1.000	0.695
3	0.930	0.990	0.969	0.960	1.000	1.000	0.975	0.975	1.000	1.000	0.928
4	0.898	0.982	0.953	0.934	1.000	1.000	0.977	0.977	1.000	1.000	0.900
5	0.930	0.924	0.942	1.000	1.000	1.000	1.000	1.000	1.000	1.000	0.921
6	0.942	0.973	0.967	0.985	0.996	0.996	0.991	0.991	1.000	1.000	0.919
7	0.906	0.924	0.939	1.000	1.000	1.000	1.000	1.000	1.000	1.000	0.906

POSITIVE NUMBER: CONSTRAINT SATISFIED. | THESE VALUES ARE NORMALIZED
 NEGATIVE NUMBER: CONSTRAINT VIOLATED. | BETWEEN +1. AND -1.
 1.000 : CONSTRAINT NOT RELEVANT OR NULLIFIED BY USER.
 -2.000 : CONSTRAINT SUPPRESSED.
 -- : STRAKE NOT EVALUATED.

Analytical Cresting

INITIAL FRAME ADEQUACY PARAMETER VALUES - MODULE 2 OF SUBSTR. 2

STRAKE	FCPH1	FCPH2	FCPH3	FYCF1	FYCF2	FYCF3	FYTF1	FYTF2	FYTF3	FYCP1	FYCP2	FYCP3	FYTP1	FYTP2	FYTP3
1	0.979	0.977	0.978	0.975	0.973	0.974	0.981	0.967	0.974	0.984	0.982	0.983	0.985	0.984	0.985
2	0.921	0.945	0.987	0.904	1.000	1.000	1.000	0.875	0.969	1.000	0.986	1.000	0.964	0.987	0.975
3	0.947	0.952	0.995	0.932	1.000	0.994	1.000	0.922	0.990	1.000	0.990	1.000	0.974	1.000	0.987
4	0.934	0.955	0.980	1.000	0.773	1.000	0.769	0.945	0.785	0.785	0.991	0.785	0.990	0.785	0.983
5	0.988	0.997	0.994	0.984	0.980	0.983	0.980	0.966	0.973	0.979	0.984	0.982	0.955	0.958	0.957
6	0.945	0.949	0.997	1.000	0.923	0.993	0.925	1.000	0.993	0.979	0.995	0.991	1.000	0.987	1.000
7	0.954	0.951	0.973	0.915	1.000	0.949	0.979	0.918	0.979	0.959	0.946	0.948	0.949	1.000	0.968

MAESTRO Cresting

INITIAL FRAME ADEQUACY PARAMETER VALUES - MODULE 2 OF SUBSTR. 2

STRAKE	FCPH1	FCPH2	FCPH3	FYCF1	FYCF2	FYCF3	FYTF1	FYTF2	FYTF3	FYCP1	FYCP2	FYCP3	FYTP1	FYTP2	FYTP3
1	0.931	0.969	0.950	0.918	0.970	0.944	0.987	0.964	0.975	0.988	0.979	0.984	0.949	0.970	0.960
2	0.919	0.942	0.987	0.912	1.000	1.000	1.000	0.860	0.955	1.000	0.986	1.000	0.952	0.979	0.966
3	0.955	0.964	0.992	0.942	1.000	1.000	1.000	0.930	0.991	1.000	0.994	1.000	0.973	0.993	0.984
4	0.946	0.913	0.972	0.916	0.848	1.000	0.843	0.844	0.855	0.855	0.937	0.987	0.936	0.855	0.855
5	0.976	0.983	0.979	0.971	0.975	0.973	0.973	0.955	0.965	0.989	0.989	0.989	0.945	0.950	0.948
6	0.942	0.939	0.997	1.000	0.913	0.991	0.917	1.000	0.993	0.982	0.995	0.991	1.000	0.981	0.992
7	0.907	0.960	0.944	0.855	0.957	0.916	1.000	0.919	0.986	0.951	0.932	0.934	0.934	0.966	0.962

POSITIVE NUMBER: CONSTRAINT SATISFIED. | THESE VALUES ARE NORMALIZED
 NEGATIVE NUMBER: CONSTRAINT VIOLATED. | BETWEEN +1. AND -1.
 1.000 : CONSTRAINT NOT RELEVANT OR NULLIFIED BY USER.
 -2.000 : CONSTRAINT SUPPRESSED.
 -- : STRAKE NOT EVALUATED.

Analytical Cresting

INITIAL PANEL ADEQUACY PARAMETER VALUES - MODULE 3 OF SUBSTR. 2

STRAKE	PCSF	PCCB	PCMY	PCSB	PYTF	PYTP	PYCF	PYCP	PSPBT	PSPBL	PFLB
1	0.812	0.905	0.944	0.911	1.000	1.000	0.954	0.954	1.000	1.000	0.793
2	0.862	0.967	0.920	0.878	1.000	1.000	0.921	0.921	1.000	1.000	0.861
3	0.966	0.994	0.981	0.977	1.000	1.000	0.986	0.986	1.000	1.000	0.964
4	0.950	0.987	0.969	0.978	1.000	1.000	0.986	0.986	1.000	1.000	0.947
5	0.935	0.900	0.982	1.000	1.000	1.000	1.000	1.000	1.000	1.000	0.935
6	0.964	0.981	0.979	0.988	1.000	1.000	0.993	0.993	1.000	1.000	0.948
7	0.917	0.923	0.956	1.000	1.000	1.000	1.000	1.000	1.000	1.000	0.908

MAESTRO Cresting

INITIAL PANEL ADEQUACY PARAMETER VALUES - MODULE 3 OF SUBSTR. 2

STRAKE	PCSF	PCCB	PCMY	PCSB	PYTF	PYTP	PYCF	PYCP	PSPBT	PSPBL	PFLB
1	0.756	0.927	0.911	0.884	1.000	1.000	0.939	0.939	1.000	1.000	0.737
2	0.812	0.957	0.891	0.838	1.000	1.000	0.894	0.894	1.000	1.000	0.811
3	0.955	0.989	0.973	0.963	1.000	1.000	0.977	0.977	1.000	1.000	0.953
4	0.926	0.992	0.948	0.967	1.000	1.000	0.978	0.978	1.000	1.000	0.924
5	0.931	0.925	0.962	1.000	1.000	1.000	1.000	1.000	1.000	1.000	0.931
6	0.949	0.993	0.966	0.983	1.000	1.000	0.989	0.989	1.000	1.000	0.942
7	0.893	0.948	0.930	1.000	1.000	1.000	1.000	1.000	1.000	1.000	0.894

POSITIVE NUMBER: CONSTRAINT SATISFIED. | THESE VALUES ARE NORMALIZED
 NEGATIVE NUMBER: CONSTRAINT VIOLATED. | BETWEEN +1. AND -1.
 1.000 : CONSTRAINT NOT RELEVANT OR NULLIFIED BY USER.
 -2.000 : CONSTRAINT SUPPRESSED.
 -- : STRAKE NOT EVALUATED.

Analytical Cresting

INITIAL FRAME ADEQUACY PARAMETER VALUES - MODULE 3 OF SUBSTR. 2

STRAKE	FCPH1	FCPH2	FCPH3	FYCF1	FYCF2	FYCF3	FYTF1	FYTF2	FYTF3	FYCP1	FYCP2	FYCP3	FYTP1	FYTP2	FYTP3
1	0.989	0.971	0.987	0.989	0.995	0.992	0.993	0.954	0.976	0.991	0.986	0.989	0.992	0.994	0.993
2	0.946	0.949	0.991	0.936	1.000	1.000	1.000	0.915	0.983	1.000	0.992	0.996	0.972	1.000	0.986
3	0.949	0.955	0.996	0.931	1.000	1.000	1.000	0.926	0.992	1.000	0.990	1.000	0.980	1.000	0.991
4	0.981	0.946	0.980	0.970	1.000	1.000	1.000	0.907	0.960	1.000	0.982	0.984	0.984	0.997	0.995
5	0.986	0.992	0.991	0.998	0.995	0.997	0.984	0.990	0.988	0.984	0.988	0.986	1.000	1.000	1.000
6	0.950	0.957	0.995	1.000	0.934	1.000	0.925	1.000	0.991	0.984	1.000	0.992	1.000	0.987	1.000
7	0.932	0.913	0.989	0.872	1.000	1.000	1.000	0.857	0.916	1.000	0.913	0.916	0.916	1.000	1.000

MAESTRO Cresting

INITIAL FRAME ADEQUACY PARAMETER VALUES - MODULE 3 OF SUBSTR. 2

STRAKE	FCPH1	FCPH2	FCPH3	FYCF1	FYCF2	FYCF3	FYTF1	FYTF2	FYTF3	FYCP1	FYCP2	FYCP3	FYTP1	FYTP2	FYTP3
1	0.835	0.938	0.936	0.784	1.000	0.926	1.000	0.909	1.000	1.000	0.970	0.982	0.933	1.000	0.964
2	0.928	0.921	0.994	0.911	1.000	1.000	1.000	0.875	0.970	1.000	0.985	0.993	0.964	1.000	0.984
3	0.948	0.952	0.995	0.926	1.000	0.992	1.000	0.933	0.993	1.000	0.985	0.993	0.984	1.000	0.992
4	0.971	0.828	0.912	0.959	0.761	0.874	0.969	1.000	1.000	0.970	1.000	1.000	0.971	0.941	0.961
5	0.953	0.973	0.963	0.923	0.947	0.935	1.000	1.000	1.000	0.981	0.977	0.977	0.975	0.981	0.978
6	0.923	0.900	0.988	1.000	0.857	0.980	0.884	1.000	1.000	0.979	1.000	0.991	1.000	0.965	0.985
7	0.926	0.810	0.881	0.892	0.724	0.811	1.000	1.000	1.000	0.914	0.975	1.000	0.917	0.907	0.913

POSITIVE NUMBER: CONSTRAINT SATISFIED. | THESE VALUES ARE NORMALIZED
 NEGATIVE NUMBER: CONSTRAINT VIOLATED. | BETWEEN +1. AND -1.
 1.000 : CONSTRAINT NOT RELEVANT OR NULLIFIED BY USER.
 -2.000 : CONSTRAINT SUPPRESSED.
 -- : STRAKE NOT EVALUATED.

Appendix G. Comparison of Results for Longitudinal Positive Twisting

Analytical Positive Twist

INITIAL PANEL ADEQUACY PARAMETER VALUES - MODULE 1 OF SUBSTR. 1

STRAKE	PCSF	PCCB	PCMY	PCSB	PYTF	PYTP	PYCF	PYCP	PSPBT	PSPBL	PFLB
1	0.888	0.943	0.966	0.954	1.000	1.000	0.976	0.976	1.000	1.000	0.875
2	0.923	0.986	0.960	0.942	1.000	1.000	0.964	0.964	1.000	1.000	0.921
3	0.974	0.998	0.987	0.990	1.000	1.000	0.994	0.994	1.000	1.000	0.954
4	0.968	0.988	0.979	0.994	1.000	1.000	0.996	0.996	1.000	1.000	0.966
5	0.978	0.991	0.995	1.000	1.000	1.000	1.000	1.000	1.000	1.000	0.978
6	0.969	0.982	0.985	0.994	1.000	1.000	0.996	0.996	1.000	1.000	0.925
7	0.962	0.974	0.976	1.000	1.000	1.000	1.000	1.000	1.000	1.000	0.938

MAESTRO Positive Twist

INITIAL PANEL ADEQUACY PARAMETER VALUES - MODULE 1 OF SUBSTR. 1

STRAKE	PCSF	PCCB	PCMY	PCSB	PYTF	PYTP	PYCF	PYCP	PSPBT	PSPBL	PFLB
1	0.893	0.953	0.956	0.966	1.000	1.000	0.983	0.983	1.000	1.000	0.880
2	0.933	0.989	0.964	0.955	1.000	1.000	0.972	0.972	1.000	1.000	0.930
3	0.976	0.999	0.988	0.994	1.000	1.000	0.997	0.997	1.000	1.000	0.955
4	0.966	0.993	0.976	0.997	0.999	0.999	0.998	0.998	1.000	1.000	0.957
5	0.980	0.998	0.988	1.000	1.000	1.000	1.000	1.000	1.000	1.000	0.980
6	0.968	0.985	0.981	0.996	1.000	1.000	0.997	0.997	1.000	1.000	0.934
7	0.960	0.993	0.973	1.000	1.000	1.000	1.000	1.000	1.000	1.000	0.947

POSITIVE NUMBER: CONSTRAINT SATISFIED. | THESE VALUES ARE NORMALIZED
 NEGATIVE NUMBER: CONSTRAINT VIOLATED. | BETWEEN +1. AND -1.
 1.000 : CONSTRAINT NOT RELEVANT OR NULLIFIED BY USER.
 -2.000 : CONSTRAINT SUPPRESSED.
 -- : STRAKE NOT EVALUATED.

Analytical Positive Twist

INITIAL FRAME ADEQUACY PARAMETER VALUES - MODULE 1 OF SUBSTR. 1

STRAKE	FCPH1	FCPH2	FCPH3	FYCF1	FYCF2	FYCF3	FYTF1	FYTF2	FYTF3	FYCP1	FYCP2	FYCP3	FYTP1	FYTP2	FYTP3
1	0.934	0.891	0.972	0.912	1.000	1.000	1.000	0.843	0.953	1.000	0.968	0.984	0.971	1.000	1.000
2	0.836	0.973	0.925	0.782	1.000	0.902	1.000	0.954	1.000	1.000	0.987	1.000	0.950	1.000	0.977
3	0.894	0.905	0.994	0.842	1.000	0.984	1.000	0.848	1.000	1.000	0.972	1.000	0.963	1.000	0.983
4	0.983	0.978	0.986	1.000	0.992	1.000	0.976	0.962	0.976	0.994	0.994	0.996	1.000	0.996	1.000
5	0.991	0.993	0.993	0.983	0.990	0.987	1.000	1.000	1.000	0.992	0.992	0.992	0.996	0.995	0.996
6	0.898	0.908	0.994	1.000	0.856	1.000	0.842	1.000	0.983	0.965	1.000	0.984	1.000	0.972	1.000
7	0.896	0.881	0.987	0.818	1.000	1.000	1.000	0.803	0.882	1.000	0.880	0.883	0.881	1.000	1.000

MAESTRO Positive Twist

INITIAL FRAME ADEQUACY PARAMETER VALUES - MODULE 1 OF SUBSTR. 1

STRAKE	FCPH1	FCPH2	FCPH3	FYCF1	FYCF2	FYCF3	FYTF1	FYTF2	FYTF3	FYCP1	FYCP2	FYCP3	FYTP1	FYTP2	FYTP3
1	0.906	0.876	0.978	0.870	1.000	1.000	1.000	0.823	0.961	1.000	0.968	0.981	0.971	1.000	1.000
2	0.828	0.974	0.922	0.768	1.000	0.896	1.000	0.952	1.000	1.000	0.986	1.000	0.955	1.000	0.979
3	0.907	0.919	0.993	0.855	1.000	0.984	1.000	0.867	1.000	1.000	0.980	1.000	0.973	1.000	0.985
4	0.969	0.953	0.992	0.948	1.000	0.991	1.000	0.923	0.980	1.000	0.983	0.985	0.984	1.000	0.995
5	0.988	0.994	0.992	0.978	0.987	0.983	1.000	1.000	1.000	1.000	0.991	0.991	0.992	0.997	0.997
6	0.904	0.911	0.995	1.000	0.855	1.000	0.849	1.000	0.984	0.973	1.000	0.985	1.000	0.977	1.000
7	0.874	0.894	0.977	0.794	1.000	0.877	1.000	0.815	1.000	1.000	0.876	0.880	0.876	1.000	0.878

POSITIVE NUMBER: CONSTRAINT SATISFIED. | THESE VALUES ARE NORMALIZED
 NEGATIVE NUMBER: CONSTRAINT VIOLATED. | BETWEEN +1. AND -1.
 1.000 : CONSTRAINT NOT RELEVANT OR NULLIFIED BY USER.
 -2.000 : CONSTRAINT SUPPRESSED.
 -- : STRAKE NOT EVALUATED.

Analytical Positive Twist

INITIAL PANEL ADEQUACY PARAMETER VALUES - MODULE 2 OF SUBSTR. 1

STRAKE	PCSF	PCCB	PCMY	PCSB	PYTF	PYTP	PYCF	PYCP	PSPBT	PSPBL	PFLB
1	0.843	0.953	0.918	0.958	0.993	0.993	0.978	0.978	1.000	1.000	0.837
2	0.907	0.983	0.907	0.970	1.000	1.000	0.981	0.981	1.000	1.000	0.907
3	0.891	0.809	0.933	0.983	1.000	1.000	0.990	0.990	1.000	1.000	0.782
4	0.938	0.923	0.969	0.990	0.990	0.990	0.993	0.993	1.000	1.000	0.875
5	0.821	0.991	0.863	1.000	1.000	1.000	1.000	1.000	1.000	1.000	0.821
6	0.854	0.729	0.917	0.984	1.000	1.000	0.990	0.990	1.000	1.000	0.696
7	0.583	0.940	0.690	1.000	1.000	1.000	1.000	1.000	1.000	1.000	0.581

MAESTRO Positive Twist

INITIAL PANEL ADEQUACY PARAMETER VALUES - MODULE 2 OF SUBSTR. 1

STRAKE	PCSF	PCCB	PCMY	PCSB	PYTF	PYTP	PYCF	PYCP	PSPBT	PSPBL	PFLB
1	0.859	0.965	0.925	0.970	0.993	0.993	0.984	0.984	1.000	1.000	0.854
2	0.932	0.989	0.929	0.975	0.999	0.999	0.985	0.985	1.000	1.000	0.926
3	0.918	0.844	0.950	0.990	1.000	1.000	0.994	0.994	1.000	1.000	0.830
4	0.952	0.939	0.970	0.996	0.988	0.988	0.997	0.997	1.000	1.000	0.902
5	0.840	0.989	0.879	1.000	1.000	1.000	1.000	1.000	1.000	1.000	0.841
6	0.886	0.770	0.932	0.984	1.000	1.000	0.990	0.990	1.000	1.000	0.740
7	0.827	0.992	0.878	1.000	1.000	1.000	1.000	1.000	1.000	1.000	0.828

POSITIVE NUMBER: CONSTRAINT SATISFIED. | THESE VALUES ARE NORMALIZED
 NEGATIVE NUMBER: CONSTRAINT VIOLATED. | BETWEEN +1. AND -1.
 1.000 : CONSTRAINT NOT RELEVANT OR NULLIFIED BY USER.
 -2.000 : CONSTRAINT SUPPRESSED.
 --- : STRAKE NOT EVALUATED.

Analytical Positive Twist

INITIAL FRAME ADEQUACY PARAMETER VALUES - MODULE 2 OF SUBSTR. 1

STRAKE	FCPH1	FCPH2	FCPH3	FYCF1	FYCF2	FYCF3	FYTF1	FYTF2	FYTF3	FYCP1	FYCP2	FYCP3	FYTP1	FYTP2	FYTP3
1	0.964	0.986	0.985	0.969	1.000	0.992	1.000	0.974	0.993	0.996	0.992	0.994	0.972	0.985	0.978
2	0.947	0.947	0.998	0.917	1.000	1.000	0.992	0.906	0.948	1.000	0.985	0.993	0.937	0.948	0.943
3	0.915	0.923	0.995	0.868	0.993	0.946	1.000	0.877	1.000	0.954	0.942	0.948	0.978	1.000	0.988
4	0.988	0.979	0.986	0.990	0.965	0.978	0.987	0.968	0.979	0.977	0.980	0.979	1.000	1.000	1.000
5	0.961	0.991	0.985	0.980	0.986	0.985	0.938	0.893	0.918	0.998	0.987	0.988	0.869	0.882	0.876
6	0.918	0.929	0.994	0.989	0.883	0.945	0.874	1.000	0.988	0.928	0.939	0.934	1.000	0.985	1.000
7	0.916	0.893	0.981	0.847	1.000	0.947	0.842	0.807	0.824	0.925	0.895	0.898	0.828	0.834	0.831

MAESTRO Positive Twist

INITIAL FRAME ADEQUACY PARAMETER VALUES - MODULE 2 OF SUBSTR. 1

STRAKE	FCPH1	FCPH2	FCPH3	FYCF1	FYCF2	FYCF3	FYTF1	FYTF2	FYTF3	FYCP1	FYCP2	FYCP3	FYTP1	FYTP2	FYTP3
1	0.973	0.988	0.988	0.971	1.000	0.991	1.000	0.981	1.000	0.996	0.991	0.994	0.980	0.989	0.985
2	0.954	0.954	0.998	0.930	1.000	1.000	0.990	0.923	0.957	1.000	0.987	0.995	0.949	0.957	0.953
3	0.939	0.949	0.995	0.904	0.980	0.955	1.000	0.917	1.000	0.962	0.955	0.958	0.984	1.000	0.992
4	0.966	0.940	0.987	0.940	1.000	0.984	1.000	0.905	0.973	0.984	0.977	0.981	0.981	1.000	1.000
5	0.975	0.994	0.990	0.978	0.981	0.979	0.950	0.917	0.934	0.998	0.992	0.992	0.898	0.906	0.902
6	0.938	0.946	0.995	0.980	0.910	0.953	0.905	1.000	0.991	0.940	0.947	0.944	1.000	0.989	1.000
7	0.899	0.919	0.989	0.832	1.000	0.902	0.961	0.856	0.934	0.949	0.901	0.903	0.902	0.936	0.930

POSITIVE NUMBER: CONSTRAINT SATISFIED. | THESE VALUES ARE NORMALIZED
 NEGATIVE NUMBER: CONSTRAINT VIOLATED. | BETWEEN +1. AND -1.
 1.000 : CONSTRAINT NOT RELEVANT OR NULLIFIED BY USER.
 -2.000 : CONSTRAINT SUPPRESSED.
 -- : STRAKE NOT EVALUATED.

Analytical Positive Twist

INITIAL PANEL ADEQUACY PARAMETER VALUES - MODULE 1 OF SUBSTR. 2

STRAKE	PCSF	PCCB	PCMY	PCSB	PYTF	PYTP	PYCF	PYCP	PSPBT	PSPBL	PFLB
1	0.910	0.981	0.951	0.948	1.000	1.000	0.952	0.952	1.000	1.000	0.909
2	0.726	0.922	0.881	0.750	1.000	1.000	0.906	0.906	1.000	1.000	0.727
3	0.702	0.750	0.849	0.903	1.000	1.000	0.952	0.952	1.000	1.000	0.680
5	0.632	0.547	0.847	1.000	1.000	1.000	1.000	1.000	1.000	1.000	0.633
6	0.920	0.982	0.971	0.968	0.996	0.996	0.971	0.971	1.000	1.000	0.885

MAESTRO Positive Twist

INITIAL PANEL ADEQUACY PARAMETER VALUES - MODULE 1 OF SUBSTR. 2

STRAKE	PCSF	PCCB	PCMY	PCSB	PYTF	PYTP	PYCF	PYCP	PSPBT	PSPBL	PFLB
1	0.911	0.981	0.949	0.947	1.000	1.000	0.951	0.951	1.000	1.000	0.910
2	0.751	0.926	0.880	0.761	1.000	1.000	0.910	0.910	1.000	1.000	0.753
3	0.682	0.749	0.837	0.913	1.000	1.000	0.957	0.957	1.000	1.000	0.661
5	0.619	0.531	0.841	1.000	1.000	1.000	1.000	1.000	1.000	1.000	0.619
6	0.926	0.978	0.970	0.968	0.990	0.990	0.970	0.970	1.000	1.000	0.891

POSITIVE NUMBER: CONSTRAINT SATISFIED. | THESE VALUES ARE NORMALIZED
 NEGATIVE NUMBER: CONSTRAINT VIOLATED. | BETWEEN +1. AND -1.
 1.000 : CONSTRAINT NOT RELEVANT OR NULLIFIED BY USER.
 -2.000 : CONSTRAINT SUPPRESSED.
 -- : STRAKE NOT EVALUATED.

Analytical Positive Twist

INITIAL FRAME ADEQUACY PARAMETER VALUES - MODULE 1 OF SUBSTR. 2

STRAKE	FCPH1	FCPH2	FCPH3	FYCF1	FYCF2	FYCF3	FYTF1	FYTF2	FYTF3	FYCP1	FYCP2	FYCP3	FYTP1	FYTP2	FYTP3
1	0.894	0.878	0.992	1.000	0.768	0.896	0.820	1.000	1.000	0.898	1.000	0.901	1.000	0.900	1.000
2	0.840	0.868	0.978	0.767	1.000	1.000	1.000	0.712	0.868	1.000	1.000	1.000	0.857	0.873	0.868
3	0.934	0.956	0.960	0.963	0.946	0.986	0.945	0.962	0.986	0.979	1.000	0.986	0.910	0.939	0.925
5	0.965	0.988	0.976	0.960	0.977	0.970	0.897	0.924	0.911	0.979	0.975	0.977	0.941	0.930	0.935
6	0.892	0.873	0.989	0.796	1.000	0.963	1.000	0.780	0.898	0.991	0.896	0.898	0.896	1.000	1.000

MAESTRO Positive Twist

INITIAL FRAME ADEQUACY PARAMETER VALUES - MODULE 1 OF SUBSTR. 2

STRAKE	FCPH1	FCPH2	FCPH3	FYCF1	FYCF2	FYCF3	FYTF1	FYTF2	FYTF3	FYCP1	FYCP2	FYCP3	FYTP1	FYTP2	FYTP3
1	0.857	0.841	0.991	1.000	0.706	0.864	0.758	1.000	1.000	0.865	1.000	0.869	1.000	0.867	1.000
2	0.805	0.835	0.977	0.714	1.000	1.000	1.000	0.654	0.838	1.000	1.000	1.000	0.824	0.843	0.837
3	0.932	0.951	0.961	0.961	0.938	0.985	0.938	0.955	0.984	0.978	1.000	0.985	0.908	0.940	0.924
5	0.964	0.983	0.973	0.960	0.976	0.968	0.891	0.911	0.901	0.980	0.977	0.979	0.937	0.929	0.933
6	0.855	0.834	0.988	0.733	1.000	0.950	1.000	0.717	0.865	0.989	0.862	0.865	0.863	1.000	1.000

POSITIVE NUMBER: CONSTRAINT SATISFIED. | THESE VALUES ARE NORMALIZED

NEGATIVE NUMBER: CONSTRAINT VIOLATED. | BETWEEN +1. AND -1.

1.000 : CONSTRAINT NOT RELEVANT OR NULLIFIED BY USER.

-2.000 : CONSTRAINT SUPPRESSED.

-- : STRAKE NOT EVALUATED.

Analytical Positive Twist

INITIAL PANEL ADEQUACY PARAMETER VALUES - MODULE 2 OF SUBSTR. 2

STRAKE	PCSF	PCCB	PCMY	PCSB	PYTF	PYTP	PYCF	PYCP	PSPBT	PSPBL	PFLB
1	0.822	0.887	0.935	0.931	1.000	1.000	0.964	0.964	1.000	1.000	0.811
2	0.846	0.968	0.905	0.873	1.000	1.000	0.917	0.917	1.000	1.000	0.845
3	0.960	0.988	0.988	0.987	1.000	1.000	0.992	0.992	1.000	1.000	0.955
4	0.970	0.982	0.989	0.988	0.996	0.996	0.996	0.996	1.000	1.000	0.971
5	0.941	0.923	0.947	1.000	1.000	1.000	1.000	1.000	1.000	1.000	0.936
6	0.964	0.985	0.982	0.996	0.992	0.992	0.998	0.998	1.000	1.000	0.925
7	0.922	0.955	0.938	1.000	1.000	1.000	1.000	1.000	1.000	1.000	0.898

MAESTRO Positive Twist

INITIAL PANEL ADEQUACY PARAMETER VALUES - MODULE 2 OF SUBSTR. 2

STRAKE	PCSF	PCCB	PCMY	PCSB	PYTF	PYTP	PYCF	PYCP	PSPBT	PSPBL	PFLB
1	0.826	0.987	0.925	0.938	1.000	1.000	0.968	0.968	1.000	1.000	0.818
2	0.864	0.970	0.910	0.880	1.000	1.000	0.922	0.922	1.000	1.000	0.864
3	0.965	0.981	0.989	0.990	1.000	1.000	0.994	0.994	1.000	1.000	0.936
4	0.978	1.000	0.988	1.000	0.993	0.993	1.000	1.000	1.000	1.000	0.973
5	0.918	0.998	0.922	1.000	1.000	1.000	1.000	1.000	1.000	1.000	0.916
6	0.963	1.000	0.972	0.996	0.985	0.985	1.000	1.000	1.000	1.000	0.915
7	0.949	0.994	0.953	1.000	1.000	1.000	1.000	1.000	1.000	1.000	0.840

POSITIVE NUMBER: CONSTRAINT SATISFIED. | THESE VALUES ARE NORMALIZED
 NEGATIVE NUMBER: CONSTRAINT VIOLATED. | BETWEEN +1. AND -1.
 1.000 : CONSTRAINT NOT RELEVANT OR NULLIFIED BY USER.
 -2.000 : CONSTRAINT SUPPRESSED.
 -- : STRAKE NOT EVALUATED.

Analytical Positive Twist

INITIAL FRAME ADEQUACY PARAMETER VALUES - MODULE 2 OF SUBSTR. 2

STRAKE	FCPH1	FCPH2	FCPH3	FYCF1	FYCF2	FYCF3	FYTF1	FYTF2	FYTF3	FYCP1	FYCP2	FYCP3	FYTP1	FYTP2	FYTP3
1	0.966	0.988	0.978	0.955	0.986	0.971	0.994	0.971	0.982	0.988	0.981	0.985	0.979	0.992	0.986
2	0.908	0.930	0.987	0.877	1.000	1.000	1.000	0.863	0.975	1.000	0.984	1.000	0.962	0.993	0.980
3	0.914	0.922	0.994	0.885	1.000	0.989	1.000	0.883	0.988	1.000	0.981	0.993	0.967	1.000	0.986
4	0.943	0.946	0.973	0.969	0.877	1.000	0.857	0.908	0.874	0.877	0.968	0.878	0.969	0.878	0.996
5	0.990	0.991	0.991	0.975	0.976	0.976	0.986	0.975	0.981	0.985	0.985	0.985	0.966	0.969	0.968
6	0.908	0.912	0.997	1.000	0.873	0.987	0.873	1.000	0.988	0.968	0.995	0.987	1.000	0.975	1.000
7	0.915	0.942	0.978	0.855	1.000	0.918	1.000	0.893	0.969	0.952	0.920	0.922	0.922	1.000	0.937

MAESTRO Positive Twist

INITIAL FRAME ADEQUACY PARAMETER VALUES - MODULE 2 OF SUBSTR. 2

STRAKE	FCPH1	FCPH2	FCPH3	FYCF1	FYCF2	FYCF3	FYTF1	FYTF2	FYTF3	FYCP1	FYCP2	FYCP3	FYTP1	FYTP2	FYTP3
1	0.821	0.983	0.906	0.775	1.000	0.884	1.000	0.965	0.986	1.000	0.966	1.000	0.880	0.966	0.927
2	0.888	0.900	0.987	0.843	1.000	1.000	1.000	0.825	0.972	1.000	0.977	0.989	0.959	1.000	0.981
3	0.902	0.913	0.990	0.857	1.000	0.977	1.000	0.882	1.000	1.000	0.967	0.986	0.974	1.000	1.000
4	0.937	0.931	0.951	0.864	0.930	0.913	0.910	0.851	0.885	0.917	0.884	0.885	0.886	0.996	0.997
5	0.835	0.899	0.873	0.788	0.847	0.819	0.976	0.963	0.970	1.000	1.000	1.000	0.854	0.886	0.871
6	0.846	0.805	0.975	1.000	0.733	0.956	0.777	1.000	1.000	0.957	1.000	0.989	1.000	0.928	0.969
7	0.861	0.629	0.740	0.759	0.492	0.620	1.000	0.916	1.000	0.937	0.920	0.922	0.844	0.830	0.839

POSITIVE NUMBER: CONSTRAINT SATISFIED. | THESE VALUES ARE NORMALIZED
 NEGATIVE NUMBER: CONSTRAINT VIOLATED. | BETWEEN +1. AND -1.
 1.000 : CONSTRAINT NOT RELEVANT OR NULLIFIED BY USER.
 -2.000 : CONSTRAINT SUPPRESSED.
 -- : STRAKE NOT EVALUATED.

Analytical Positive Twist

INITIAL PANEL ADEQUACY PARAMETER VALUES - MODULE 3 OF SUBSTR. 2

STRAKE	PCSF	PCCB	PCMY	PCSB	PYTF	PYTP	PYCF	PYCP	PSPBT	PSPBL	PFLB
1	0.856	0.916	0.968	0.934	1.000	1.000	0.966	0.966	1.000	1.000	0.846
2	0.898	0.977	0.938	0.906	1.000	1.000	0.939	0.939	1.000	1.000	0.897
3	0.970	0.997	0.986	0.986	1.000	1.000	0.992	0.992	1.000	1.000	0.953
4	0.972	0.992	0.987	0.989	1.000	1.000	0.993	0.993	1.000	1.000	0.970
5	0.955	0.937	0.986	1.000	1.000	1.000	1.000	1.000	1.000	1.000	0.955
6	0.972	0.984	0.989	0.993	1.000	1.000	0.996	0.996	1.000	1.000	0.929
7	0.961	0.951	0.987	1.000	1.000	1.000	1.000	1.000	1.000	1.000	0.930

MAESTRO Positive Twist

INITIAL PANEL ADEQUACY PARAMETER VALUES - MODULE 3 OF SUBSTR. 2

STRAKE	PCSF	PCCB	PCMY	PCSB	PYTF	PYTP	PYCF	PYCP	PSPBT	PSPBL	PFLB
1	0.851	0.974	0.952	0.949	1.000	1.000	0.974	0.974	1.000	1.000	0.846
2	0.893	0.973	0.947	0.917	1.000	1.000	0.946	0.946	1.000	1.000	0.891
3	0.967	0.979	0.987	0.994	1.000	1.000	0.996	0.996	1.000	1.000	0.929
4	0.975	0.999	0.972	0.996	0.995	0.995	0.998	0.998	1.000	1.000	0.974
5	0.977	0.992	0.969	1.000	1.000	1.000	1.000	1.000	1.000	1.000	0.975
6	0.976	1.000	0.980	0.999	0.994	0.994	1.000	1.000	1.000	1.000	0.934
7	0.950	0.991	0.952	1.000	1.000	1.000	1.000	1.000	1.000	1.000	0.950

POSITIVE NUMBER: CONSTRAINT SATISFIED. | THESE VALUES ARE NORMALIZED
 NEGATIVE NUMBER: CONSTRAINT VIOLATED. | BETWEEN +1. AND -1.
 1.000 : CONSTRAINT NOT RELEVANT OR NULLIFIED BY USER.
 -2.000 : CONSTRAINT SUPPRESSED.
 -- : STRAKE NOT EVALUATED.

Analytical Positive Twist

INITIAL FRAME ADEQUACY PARAMETER VALUES - MODULE 3 OF SUBSTR. 2

STRAKE	FCPH1	FCPH2	FCPH3	FYCF1	FYCF2	FYCF3	FYTF1	FYTF2	FYTF3	FYCP1	FYCP2	FYCP3	FYTP1	FYTP2	FYTP3
1	0.948	0.948	0.990	0.936	1.000	0.992	1.000	0.924	0.982	0.993	0.980	0.988	0.978	1.000	0.990
2	0.922	0.933	0.989	0.897	1.000	0.993	1.000	0.897	0.989	1.000	0.986	0.994	0.969	1.000	0.988
3	0.883	0.891	0.995	0.841	1.000	0.984	1.000	0.843	1.000	1.000	0.970	1.000	0.958	1.000	0.983
4	0.972	0.957	0.990	1.000	0.940	0.986	0.957	0.966	0.981	0.988	0.994	0.995	0.995	0.982	0.988
5	0.993	0.994	0.996	0.983	0.988	0.987	1.000	1.000	1.000	0.991	0.991	0.991	0.996	0.995	0.996
6	0.882	0.890	0.995	1.000	0.845	1.000	0.836	1.000	0.983	0.962	1.000	0.984	1.000	0.965	1.000
7	0.903	0.898	0.992	0.828	1.000	0.897	1.000	0.828	0.893	1.000	0.890	0.893	0.892	1.000	1.000

MAESTRO Positive Twist

INITIAL FRAME ADEQUACY PARAMETER VALUES - MODULE 3 OF SUBSTR. 2

STRAKE	FCPH1	FCPH2	FCPH3	FYCF1	FYCF2	FYCF3	FYTF1	FYTF2	FYTF3	FYCP1	FYCP2	FYCP3	FYTP1	FYTP2	FYTP3
1	0.785	0.899	0.935	0.702	1.000	0.900	1.000	0.860	1.000	1.000	0.958	0.981	0.957	1.000	0.973
2	0.912	0.916	0.994	0.870	1.000	0.992	1.000	0.854	0.980	1.000	0.978	0.989	0.970	1.000	0.989
3	0.891	0.901	0.994	0.839	1.000	0.982	1.000	0.850	1.000	1.000	0.970	0.983	0.963	1.000	0.985
4	0.935	0.699	0.866	0.990	0.543	0.770	0.863	1.000	1.000	0.901	1.000	1.000	0.991	0.884	0.900
5	0.912	0.936	0.928	0.865	0.893	0.884	1.000	1.000	1.000	1.000	0.963	0.984	0.962	0.967	0.962
6	0.864	0.827	0.978	1.000	0.735	0.961	0.780	1.000	0.983	0.962	1.000	0.983	1.000	0.947	0.971
7	0.893	0.683	0.809	0.824	0.553	0.696	1.000	0.920	1.000	1.000	0.930	1.000	0.835	0.825	0.832

POSITIVE NUMBER: CONSTRAINT SATISFIED. | THESE VALUES ARE NORMALIZED
 NEGATIVE NUMBER: CONSTRAINT VIOLATED. | BETWEEN +1. AND -1.
 1.000 : CONSTRAINT NOT RELEVANT OR NULLIFIED BY USER.
 -2.000 : CONSTRAINT SUPPRESSED.
 -- : STRAKE NOT EVALUATED.

Appendix H. Comparison of Results for Longitudinal Negative Twisting

Analytical Negative Twist

INITIAL PANEL ADEQUACY PARAMETER VALUES - MODULE 1 OF SUBSTR. 1

STRAKE	PCSF	PCCB	PCMY	PCSB	PYTF	PYTP	PYCF	PYCP	PSPBT	PSPBL	PFLB
1	0.771	0.923	0.899	0.917	1.000	1.000	0.957	0.957	1.000	1.000	0.750
2	0.867	0.972	0.924	0.890	1.000	1.000	0.930	0.930	1.000	1.000	0.862
3	0.969	0.995	0.984	0.980	1.000	1.000	0.987	0.987	1.000	1.000	0.946
4	0.919	0.983	0.943	0.983	0.998	0.998	0.990	0.990	1.000	1.000	0.915
5	0.955	0.972	0.971	1.000	1.000	1.000	1.000	1.000	1.000	1.000	0.954
6	0.954	0.988	0.969	0.991	1.000	1.000	0.994	0.994	1.000	1.000	0.923
7	0.875	0.961	0.918	1.000	1.000	1.000	1.000	1.000	1.000	1.000	0.874

MAESTRO Negative Twist

INITIAL PANEL ADEQUACY PARAMETER VALUES - MODULE 1 OF SUBSTR. 1

STRAKE	PCSF	PCCB	PCMY	PCSB	PYTF	PYTP	PYCF	PYCP	PSPBT	PSPBL	PFLB
1	0.735	0.930	0.889	0.881	1.000	1.000	0.938	0.938	1.000	1.000	0.717
2	0.819	0.951	0.895	0.836	1.000	1.000	0.895	0.895	1.000	1.000	0.818
3	0.952	0.970	0.971	0.960	1.000	1.000	0.975	0.975	1.000	1.000	0.950
4	0.904	0.989	0.936	0.959	1.000	1.000	0.975	0.975	1.000	1.000	0.902
5	0.926	0.913	0.963	1.000	1.000	1.000	1.000	1.000	1.000	1.000	0.926
6	0.936	0.994	0.958	0.978	1.000	1.000	0.986	0.986	1.000	1.000	0.934
7	0.860	0.940	0.912	1.000	1.000	1.000	1.000	1.000	1.000	1.000	0.861

POSITIVE NUMBER: CONSTRAINT SATISFIED. | THESE VALUES ARE NORMALIZED
 NEGATIVE NUMBER: CONSTRAINT VIOLATED. | BETWEEN +1. AND -1.
 1.000 : CONSTRAINT NOT RELEVANT OR NULLIFIED BY USER.
 -2.000 : CONSTRAINT SUPPRESSED.
 -- : STRAKE NOT EVALUATED.

Analytical Negative Twist

INITIAL FRAME ADEQUACY PARAMETER VALUES - MODULE 1 OF SUBSTR. 1

STRAKE	FCPH1	FCPH2	FCPH3	FYCF1	FYCF2	FYCF3	FYTF1	FYTF2	FYTF3	FYCP1	FYCP2	FYCP3	FYTP1	FYTP2	FYTP3
1	0.940	0.894	0.972	0.923	1.000	1.000	1.000	0.843	0.949	1.000	0.972	0.984	0.979	1.000	1.000
2	0.836	0.976	0.926	0.792	1.000	0.916	1.000	0.940	1.000	1.000	0.984	1.000	0.957	0.994	0.977
3	0.892	0.901	0.995	0.834	1.000	0.983	1.000	0.835	1.000	1.000	0.976	1.000	0.968	1.000	0.982
4	0.967	0.963	0.984	0.967	0.970	1.000	0.943	0.940	0.972	0.988	0.987	0.990	0.990	0.990	1.000
5	0.988	0.997	0.994	0.979	0.987	0.984	1.000	1.000	1.000	0.988	0.987	0.988	1.000	1.000	1.000
6	0.895	0.905	0.995	1.000	0.847	1.000	0.833	1.000	0.982	0.972	1.000	0.984	1.000	0.975	1.000
7	0.905	0.896	0.984	0.833	1.000	0.903	1.000	0.824	0.893	1.000	0.891	0.893	0.892	1.000	0.931

MAESTRO Negative Twist

INITIAL FRAME ADEQUACY PARAMETER VALUES - MODULE 1 OF SUBSTR. 1

STRAKE	FCPH1	FCPH2	FCPH3	FYCF1	FYCF2	FYCF3	FYTF1	FYTF2	FYTF3	FYCP1	FYCP2	FYCP3	FYTP1	FYTP2	FYTP3
1	0.823	0.886	0.964	0.757	1.000	0.945	1.000	0.837	0.982	1.000	0.961	0.978	0.933	1.000	0.972
2	0.900	0.973	0.957	0.897	1.000	0.978	1.000	0.934	1.000	1.000	0.988	0.996	0.966	0.996	0.982
3	0.975	0.979	0.996	0.958	1.000	0.989	1.000	0.969	0.997	0.996	0.986	0.992	0.994	1.000	0.997
4	0.957	0.859	0.918	0.933	0.774	0.873	1.000	0.948	1.000	0.973	0.986	1.000	0.980	0.957	0.971
5	0.949	0.964	0.960	0.919	0.946	0.933	1.000	0.988	1.000	0.986	0.973	0.973	0.973	0.981	0.979
6	0.944	0.911	0.982	1.000	0.880	0.978	0.916	1.000	0.995	0.986	1.000	0.996	1.000	0.967	0.986
7	0.931	0.735	0.844	0.870	0.650	0.771	1.000	0.957	1.000	0.884	0.961	1.000	0.874	0.846	0.864

POSITIVE NUMBER: CONSTRAINT SATISFIED. | THESE VALUES ARE NORMALIZED
 NEGATIVE NUMBER: CONSTRAINT VIOLATED. | BETWEEN +1. AND -1.
 1.000 : CONSTRAINT NOT RELEVANT OR NULLIFIED BY USER.
 -2.000 : CONSTRAINT SUPPRESSED.
 -- : STRAKE NOT EVALUATED.

Analytical Negative Twist

INITIAL PANEL ADEQUACY PARAMETER VALUES - MODULE 2 OF SUBSTR. 1

STRAKE	PCSF	PCCB	PCMY	PCSB	PYTF	PYTP	PYCF	PYCP	PSPBT	PSPBL	PFLB
1	0.822	0.945	0.910	0.964	0.995	0.995	0.981	0.981	1.000	1.000	0.808
2	0.919	0.989	0.953	0.956	0.999	0.999	0.973	0.973	1.000	1.000	0.914
3	0.934	0.868	0.961	0.995	1.000	1.000	0.997	0.997	1.000	1.000	0.857
4	0.924	1.000	0.945	1.000	0.987	0.987	1.000	1.000	1.000	1.000	0.906
5	0.946	0.948	0.962	1.000	1.000	1.000	1.000	1.000	1.000	1.000	0.943
6	0.910	0.810	0.943	0.985	1.000	1.000	0.991	0.991	1.000	1.000	0.781
7	0.897	0.844	0.929	1.000	1.000	1.000	1.000	1.000	1.000	1.000	0.895

MAESTRO Negative Twist

INITIAL PANEL ADEQUACY PARAMETER VALUES - MODULE 2 OF SUBSTR. 1

STRAKE	PCSF	PCCB	PCMY	PCSB	PYTF	PYTP	PYCF	PYCP	PSPBT	PSPBL	PFLB
1	0.835	0.986	0.918	0.957	0.994	0.994	0.978	0.978	1.000	1.000	0.826
2	0.919	0.986	0.960	0.942	1.000	1.000	0.964	0.964	1.000	1.000	0.917
3	0.933	0.861	0.959	0.992	1.000	1.000	0.995	0.995	1.000	1.000	0.852
4	0.935	1.000	0.954	0.997	0.988	0.988	1.000	1.000	1.000	1.000	0.910
5	0.902	0.987	0.927	1.000	1.000	1.000	1.000	1.000	0.914	0.917	0.902
6	0.914	0.816	0.946	0.985	0.998	0.998	0.991	0.991	1.000	1.000	0.781
7	0.728	0.666	0.869	1.000	1.000	1.000	1.000	1.000	0.851	0.864	0.728

POSITIVE NUMBER: CONSTRAINT SATISFIED. | THESE VALUES ARE NORMALIZED
 NEGATIVE NUMBER: CONSTRAINT VIOLATED. | BETWEEN +1. AND -1.
 1.000 : CONSTRAINT NOT RELEVANT OR NULLIFIED BY USER.
 -2.000 : CONSTRAINT SUPPRESSED.
 -- : STRAKE NOT EVALUATED.

Analytical Negative Twist

INITIAL FRAME ADEQUACY PARAMETER VALUES - MODULE 2 OF SUBSTR. 1

STRAKE	FCPH1	FCPH2	FCPH3	FYCF1	FYCF2	FYCF3	FYTF1	FYTF2	FYTF3	FYCP1	FYCP2	FYCP3	FYTP1	FYTP2	FYTP3
1	0.987	0.990	0.995	0.978	0.997	0.988	1.000	0.986	1.000	0.995	0.990	0.992	1.000	1.000	1.000
2	0.962	0.963	0.998	0.947	1.000	1.000	0.988	0.932	0.967	1.000	0.991	0.996	0.961	0.966	0.964
3	0.948	0.957	0.996	0.918	0.972	0.962	1.000	0.931	1.000	0.967	0.964	0.965	0.987	1.000	0.993
4	0.960	0.940	0.989	0.928	1.000	0.982	1.000	0.907	0.976	0.986	0.974	0.978	0.978	1.000	1.000
5	0.992	0.998	0.996	0.975	0.980	0.978	1.000	0.992	1.000	0.991	0.990	0.991	0.981	0.983	0.982
6	0.946	0.951	0.997	0.976	0.919	0.960	0.917	1.000	0.992	0.953	0.957	0.955	1.000	0.989	1.000
7	0.913	0.942	0.981	0.856	1.000	0.919	1.000	0.893	1.000	0.982	0.921	0.960	0.921	1.000	0.923

MAESTRO Negative Twist

INITIAL FRAME ADEQUACY PARAMETER VALUES - MODULE 2 OF SUBSTR. 1

STRAKE	FCPH1	FCPH2	FCPH3	FYCF1	FYCF2	FYCF3	FYTF1	FYTF2	FYTF3	FYCP1	FYCP2	FYCP3	FYTP1	FYTP2	FYTP3
1	0.812	0.991	0.904	0.756	1.000	0.869	1.000	0.966	1.000	1.000	0.966	1.000	0.933	0.996	0.958
2	0.970	0.967	0.997	0.964	1.000	1.000	0.994	0.932	0.976	1.000	0.994	1.000	0.971	0.975	0.973
3	0.988	0.997	0.995	0.959	0.958	0.958	1.000	1.000	1.000	0.962	0.962	0.962	1.000	1.000	1.000
4	0.928	0.952	0.961	0.877	0.906	0.921	1.000	0.932	1.000	0.980	0.970	0.976	0.976	1.000	1.000
5	0.805	0.883	0.844	0.726	0.815	0.770	0.964	0.938	0.952	1.000	1.000	1.000	0.886	0.898	0.893
6	0.940	0.881	0.968	0.959	0.826	0.954	0.893	1.000	1.000	0.959	0.958	0.958	0.988	0.959	0.976
7	0.903	0.502	0.704	0.711	0.336	0.541	1.000	0.926	1.000	0.922	0.909	0.916	0.714	0.697	0.710

POSITIVE NUMBER: CONSTRAINT SATISFIED. | THESE VALUES ARE NORMALIZED
 NEGATIVE NUMBER: CONSTRAINT VIOLATED. | BETWEEN +1. AND -1.
 1.000 : CONSTRAINT NOT RELEVANT OR NULLIFIED BY USER.
 -2.000 : CONSTRAINT SUPPRESSED.
 -- : STRAKE NOT EVALUATED.

Analytical Negative Twist

INITIAL PANEL ADEQUACY PARAMETER VALUES - MODULE 1 OF SUBSTR. 2

STRAKE	PCSF	PCCB	PCMY	PCSB	PYTF	PYTP	PYCF	PYCP	PSPBT	PSPBL	PFLB
1	0.856	0.969	0.922	0.922	1.000	1.000	0.927	0.927	1.000	1.000	0.856
2	0.607	0.868	0.809	0.604	1.000	1.000	0.845	0.845	1.000	1.000	0.607
3	0.510	0.622	0.730	0.878	1.000	1.000	0.939	0.939	1.000	1.000	0.488
5	0.427	0.340	0.738	1.000	1.000	1.000	1.000	1.000	1.000	1.000	0.427
6	0.855	0.976	0.951	0.951	0.980	0.980	0.955	0.955	1.000	1.000	0.810

MAESTRO Negative Twist

INITIAL PANEL ADEQUACY PARAMETER VALUES - MODULE 1 OF SUBSTR. 2

STRAKE	PCSF	PCCB	PCMY	PCSB	PYTF	PYTP	PYCF	PYCP	PSPBT	PSPBL	PFLB
1	0.823	0.968	0.927	0.922	1.000	1.000	0.928	0.928	1.000	1.000	0.817
2	0.357	0.793	0.701	0.457	1.000	1.000	0.757	0.757	1.000	1.000	0.351
3	0.382	0.537	0.795	0.699	1.000	1.000	0.842	0.842	1.000	1.000	0.338
5	0.611	0.530	0.821	1.000	1.000	1.000	1.000	1.000	1.000	1.000	0.612
6	0.858	0.969	0.967	0.965	0.989	0.989	0.968	0.968	1.000	1.000	0.798

POSITIVE NUMBER: CONSTRAINT SATISFIED. | THESE VALUES ARE NORMALIZED
 NEGATIVE NUMBER: CONSTRAINT VIOLATED. | BETWEEN +1. AND -1.
 1.000 : CONSTRAINT NOT RELEVANT OR NULLIFIED BY USER.
 -2.000 : CONSTRAINT SUPPRESSED.
 -- : STRAKE NOT EVALUATED.

Analytical Negative Twist

INITIAL FRAME ADEQUACY PARAMETER VALUES - MODULE 1 OF SUBSTR. 2

STRAKE	FCPH1	FCPH2	FCPH3	FYCF1	FYCF2	FYCF3	FYTF1	FYTF2	FYTF3	FYCP1	FYCP2	FYCP3	FYTP1	FYTP2	FYTP3
1	0.837	0.814	0.986	1.000	0.652	0.838	0.737	1.000	1.000	0.843	1.000	0.849	1.000	0.847	1.000
2	0.756	0.785	0.976	0.662	1.000	1.000	1.000	0.553	0.785	1.000	1.000	1.000	0.769	0.798	0.787
3	0.890	0.919	0.933	0.960	0.896	0.970	0.920	0.914	0.971	0.965	1.000	0.976	0.831	0.876	0.853
5	0.931	0.982	0.956	0.919	0.952	0.936	0.795	0.830	0.812	0.953	0.947	0.950	0.855	0.840	0.847
6	0.837	0.802	0.979	0.696	1.000	0.939	1.000	0.673	0.843	0.980	0.840	0.941	0.840	1.000	0.844

MAESTRO Negative Twist

INITIAL FRAME ADEQUACY PARAMETER VALUES - MODULE 1 OF SUBSTR. 2

STRAKE	FCPH1	FCPH2	FCPH3	FYCF1	FYCF2	FYCF3	FYTF1	FYTF2	FYTF3	FYCP1	FYCP2	FYCP3	FYTP1	FYTP2	FYTP3
1	0.915	0.902	0.990	1.000	0.815	0.918	0.851	1.000	0.986	0.917	1.000	0.921	0.980	0.920	0.978
2	0.846	0.879	0.977	0.789	1.000	1.000	1.000	0.719	0.872	1.000	0.877	0.881	0.879	0.939	0.910
3	0.833	0.965	0.897	0.879	0.976	0.965	0.938	0.927	0.969	0.967	0.980	0.974	0.799	0.867	0.833
5	0.870	0.987	0.935	0.960	0.977	0.970	0.701	0.821	0.764	0.973	0.970	0.972	0.851	0.817	0.836
6	0.914	0.901	0.993	0.842	1.000	0.973	1.000	0.822	0.919	0.985	0.917	0.920	0.919	1.000	1.000

POSITIVE NUMBER: CONSTRAINT SATISFIED. | THESE VALUES ARE NORMALIZED
 NEGATIVE NUMBER: CONSTRAINT VIOLATED. | BETWEEN +1. AND -1.
 1.000 : CONSTRAINT NOT RELEVANT OR NULLIFIED BY USER.
 -2.000 : CONSTRAINT SUPPRESSED.
 -- : STRAKE NOT EVALUATED.

Analytical Negative Twist

INITIAL PANEL ADEQUACY PARAMETER VALUES - MODULE 2 OF SUBSTR. 2

STRAKE	PCSF	PCCB	PCMY	PCSB	PYTF	PYTP	PYCF	PYCP	PSPBT	PSPBL	PFLB
1	0.675	0.849	0.862	0.866	1.000	1.000	0.930	0.930	1.000	1.000	0.667
2	0.757	0.935	0.839	0.785	1.000	1.000	0.859	0.859	1.000	1.000	0.758
3	0.946	0.970	0.975	0.971	1.000	1.000	0.982	0.982	1.000	1.000	0.937
4	0.921	0.988	0.965	0.955	0.989	0.989	0.984	0.984	1.000	1.000	0.926
5	0.879	0.957	0.888	1.000	1.000	1.000	1.000	1.000	1.000	1.000	0.877
6	0.940	0.977	0.954	0.996	0.978	0.978	0.997	0.997	1.000	1.000	0.861
7	0.786	0.932	0.832	1.000	1.000	1.000	1.000	1.000	1.000	1.000	0.785

MAESTRO Negative Twist

INITIAL PANEL ADEQUACY PARAMETER VALUES - MODULE 2 OF SUBSTR. 2

STRAKE	PCSF	PCCB	PCMY	PCSB	PYTF	PYTP	PYCF	PYCP	PSPBT	PSPBL	PFLB
1	0.612	0.812	0.883	0.814	1.000	1.000	0.901	0.901	1.000	1.000	0.583
2	0.596	0.915	0.762	0.695	1.000	1.000	0.795	0.795	1.000	1.000	0.585
3	0.903	0.985	0.953	0.939	1.000	1.000	0.961	0.961	1.000	1.000	0.902
4	0.851	0.970	0.933	0.889	1.000	1.000	0.960	0.960	1.000	1.000	0.853
5	0.900	0.857	0.924	1.000	1.000	1.000	1.000	1.000	1.000	1.000	0.897
6	0.922	0.970	0.953	0.972	0.996	0.996	0.982	0.982	1.000	1.000	0.905
7	0.880	0.874	0.901	1.000	1.000	1.000	1.000	1.000	1.000	1.000	0.880

POSITIVE NUMBER: CONSTRAINT SATISFIED. | THESE VALUES ARE NORMALIZED
 NEGATIVE NUMBER: CONSTRAINT VIOLATED. | BETWEEN +1. AND -1.
 1.000 : CONSTRAINT NOT RELEVANT OR NULLIFIED BY USER.
 -2.000 : CONSTRAINT SUPPRESSED.
 -- : STRAKE NOT EVALUATED.

Analytical Negative Twist

INITIAL FRAME ADEQUACY PARAMETER VALUES - MODULE 2 OF SUBSTR. 2

STRAKE	FCPH1	FCPH2	FCPH3	FYCF1	FYCF2	FYCF3	FYTF1	FYTF2	FYTF3	FYCP1	FYCP2	FYCP3	FYTP1	FYTP2	FYTP3
1	0.963	0.973	0.968	0.963	0.976	0.969	0.950	0.935	0.943	0.982	0.980	0.981	0.966	0.970	0.968
2	0.879	0.900	0.986	0.846	1.000	1.000	1.000	0.801	0.959	1.000	0.973	0.986	0.941	0.989	0.966
3	0.855	0.859	0.996	0.808	1.000	0.985	1.000	0.793	0.977	1.000	0.965	0.986	0.942	1.000	0.975
4	0.856	0.871	0.978	1.000	0.516	1.000	0.516	1.000	0.541	0.541	1.000	0.541	1.000	0.541	0.849
5	0.977	0.982	0.987	0.973	0.969	0.975	0.965	0.939	0.953	0.987	0.988	0.988	0.914	0.921	0.917
6	0.852	0.856	0.994	1.000	0.794	0.979	0.799	1.000	0.981	0.947	0.990	0.978	1.000	0.958	1.000
7	0.931	0.919	0.936	0.918	1.000	1.000	0.907	0.874	0.930	0.937	0.932	0.935	0.943	0.972	0.976

MAESTRO Negative Twist

INITIAL FRAME ADEQUACY PARAMETER VALUES - MODULE 2 OF SUBSTR. 2

STRAKE	FCPH1	FCPH2	FCPH3	FYCF1	FYCF2	FYCF3	FYTF1	FYTF2	FYTF3	FYCP1	FYCP2	FYCP3	FYTP1	FYTP2	FYTP3
1	0.950	0.944	0.947	0.949	0.941	0.945	0.961	0.952	0.956	0.978	0.976	0.977	0.955	0.952	0.954
2	0.928	0.954	0.986	0.953	1.000	1.000	0.977	0.855	0.932	1.000	0.990	1.000	0.935	0.952	0.943
3	0.964	0.969	0.995	0.958	1.000	1.000	1.000	0.933	0.982	1.000	0.995	1.000	0.971	0.985	0.978
4	0.917	0.906	0.984	1.000	0.648	0.674	0.663	0.938	0.882	0.675	1.000	1.000	0.967	0.675	0.675
5	0.980	0.994	0.991	0.980	0.975	0.978	0.960	0.936	0.948	0.980	0.982	0.981	0.923	0.929	0.926
6	0.970	0.970	0.997	1.000	0.956	0.996	0.959	1.000	0.994	0.986	0.993	0.990	1.000	0.992	1.000
7	0.946	0.971	0.966	0.960	0.965	0.978	0.931	0.973	0.957	0.970	0.972	0.971	0.988	0.977	0.986

POSITIVE NUMBER: CONSTRAINT SATISFIED. THESE VALUES ARE NORMALIZED
 NEGATIVE NUMBER: CONSTRAINT VIOLATED. BETWEEN +1. AND -1.
 1.000 : CONSTRAINT NOT RELEVANT OR NULLIFIED BY USER.
 -2.000 : CONSTRAINT SUPPRESSED.
 -- : STRAKE NOT EVALUATED.

Analytical Negative Twist

INITIAL PANEL ADEQUACY PARAMETER VALUES - MODULE 3 OF SUBSTR. 2

STRAKE	PCSF	PCCB	PCMY	PCSB	PYTF	PYTP	PYCF	PYCP	PSPBT	PSPBL	PFLB
1	0.727	0.906	0.902	0.869	1.000	1.000	0.931	0.931	1.000	1.000	0.712
2	0.800	0.942	0.886	0.826	1.000	1.000	0.886	0.886	1.000	1.000	0.799
3	0.958	0.992	0.974	0.967	1.000	1.000	0.980	0.980	1.000	1.000	0.942
4	0.917	0.984	0.947	0.967	1.000	1.000	0.979	0.979	1.000	1.000	0.916
5	0.950	0.974	0.969	1.000	1.000	1.000	1.000	1.000	1.000	1.000	0.950
6	0.953	0.979	0.972	0.987	1.000	1.000	0.992	0.992	1.000	1.000	0.900
7	0.870	0.909	0.920	1.000	1.000	1.000	1.000	1.000	1.000	1.000	0.862

MAESTRO Negative Twist

INITIAL PANEL ADEQUACY PARAMETER VALUES - MODULE 3 OF SUBSTR. 2

STRAKE	PCSF	PCCB	PCMY	PCSB	PYTF	PYTP	PYCF	PYCP	PSPBT	PSPBL	PFLB
1	0.653	0.878	0.881	0.818	1.000	1.000	0.903	0.903	1.000	1.000	0.631
2	0.704	0.933	0.827	0.748	1.000	1.000	0.832	0.832	1.000	1.000	0.702
3	0.929	0.984	0.953	0.936	1.000	1.000	0.961	0.961	1.000	1.000	0.927
4	0.892	0.984	0.932	0.938	1.000	1.000	0.960	0.960	1.000	1.000	0.889
5	0.910	0.854	0.965	1.000	1.000	1.000	1.000	1.000	1.000	1.000	0.910
6	0.926	0.979	0.954	0.966	1.000	1.000	0.979	0.979	1.000	1.000	0.922
7	0.852	0.883	0.913	1.000	1.000	1.000	1.000	1.000	1.000	1.000	0.853

POSITIVE NUMBER: CONSTRAINT SATISFIED. | THESE VALUES ARE NORMALIZED
 NEGATIVE NUMBER: CONSTRAINT VIOLATED. | BETWEEN +1. AND -1.
 1.000 : CONSTRAINT NOT RELEVANT OR NULLIFIED BY USER.
 -2.000 : CONSTRAINT SUPPRESSED.
 -- : STRAKE NOT EVALUATED.

Analytical Negative Twist

INITIAL FRAME ADEQUACY PARAMETER VALUES - MODULE 3 OF SUBSTR. 2

STRAKE	FCPH1	FCPH2	FCPH3	FYCF1	FYCF2	FYCF3	FYTF1	FYTF2	FYTF3	FYCP1	FYCP2	FYCP3	FYTP1	FYTP2	FYTP3
1	0.955	0.942	0.977	0.952	1.000	0.988	1.000	0.903	0.952	0.994	0.983	0.989	0.973	0.989	0.981
2	0.911	0.913	0.986	0.890	1.000	1.000	1.000	0.862	0.981	1.000	0.982	0.992	0.957	1.000	0.981
3	0.869	0.875	0.995	0.809	1.000	1.000	1.000	0.799	0.979	1.000	0.966	1.000	0.951	1.000	0.978
4	0.922	0.905	0.974	1.000	0.870	0.970	0.867	1.000	0.947	0.966	1.000	0.968	1.000	0.958	0.972
5	0.989	0.993	0.992	0.979	0.988	0.985	0.991	1.000	1.000	0.989	0.988	0.989	0.991	0.990	0.991
6	0.868	0.873	0.993	1.000	0.819	1.000	0.807	1.000	0.978	0.958	1.000	0.980	1.000	0.959	1.000
7	0.915	0.875	0.972	0.843	1.000	0.948	1.000	0.799	0.886	1.000	0.887	0.891	0.890	1.000	0.948

MAESTRO Negative Twist

INITIAL FRAME ADEQUACY PARAMETER VALUES - MODULE 3 OF SUBSTR. 2

STRAKE	FCPH1	FCPH2	FCPH3	FYCF1	FYCF2	FYCF3	FYTF1	FYTF2	FYTF3	FYCP1	FYCP2	FYCP3	FYTP1	FYTP2	FYTP3
1	0.961	0.946	0.953	0.959	0.947	0.956	1.000	0.946	0.977	0.991	0.984	0.988	0.969	0.964	0.966
2	0.932	0.914	0.990	0.932	1.000	1.000	0.984	0.852	0.950	1.000	0.989	0.995	0.951	0.990	0.971
3	0.973	0.977	0.996	0.970	1.000	1.000	1.000	0.954	0.987	1.000	0.997	1.000	0.984	0.995	0.990
4	0.970	0.940	0.964	0.960	0.925	0.958	0.995	0.941	0.979	1.000	0.988	1.000	0.984	0.971	0.978
5	0.983	0.996	0.990	0.988	0.996	0.990	0.971	0.984	0.979	0.983	0.987	0.984	1.000	0.985	1.000
6	0.968	0.967	0.997	1.000	0.955	1.000	0.951	1.000	0.992	0.991	1.000	0.995	1.000	0.988	0.995
7	0.945	0.967	0.978	0.912	0.979	0.951	1.000	0.933	1.000	1.000	0.952	0.953	0.953	0.990	0.989

POSITIVE NUMBER: CONSTRAINT SATISFIED. THESE VALUES ARE NORMALIZED
 NEGATIVE NUMBER: CONSTRAINT VIOLATED. BETWEEN +1. AND -1.
 1.000 : CONSTRAINT NOT RELEVANT OR NULLIFIED BY USER.
 -2.000 : CONSTRAINT SUPPRESSED.
 -- : STRAKE NOT EVALUATED.

Appendix I. Comparison of Results for Transverse Hogging

Analytical Transverse Hogging

INITIAL PANEL ADEQUACY PARAMETER VALUES - MODULE 1 OF SUBSTR. 1

STRAKE	PCSF	PCCB	PCMY	PCSB	PYTF	PYTP	PYCF	PYCP	PSPBT	PSPBL	PFLB
1	0.605	0.743	0.856	0.810	1.000	1.000	0.899	0.899	1.000	1.000	0.556
2	0.716	0.903	0.835	0.744	1.000	1.000	0.833	0.833	1.000	1.000	0.714
3	0.932	0.985	0.956	0.940	1.000	1.000	0.962	0.962	1.000	1.000	0.930
4	0.870	0.952	0.918	0.942	1.000	1.000	0.964	0.964	1.000	1.000	0.860
5	0.934	0.933	0.964	1.000	1.000	1.000	1.000	1.000	1.000	1.000	0.922
6	0.920	0.979	0.948	0.971	1.000	1.000	0.982	0.982	1.000	1.000	0.889
7	0.844	0.924	0.897	1.000	1.000	1.000	1.000	1.000	1.000	1.000	0.845

MAESTRO Transverse Hogging

INITIAL PANEL ADEQUACY PARAMETER VALUES - MODULE 1 OF SUBSTR. 1

STRAKE	PCSF	PCCB	PCMY	PCSB	PYTF	PYTP	PYCF	PYCP	PSPBT	PSPBL	PFLB
1	0.480	0.735	0.796	0.723	1.000	1.000	0.849	0.849	1.000	1.000	0.437
2	0.583	0.855	0.752	0.625	1.000	1.000	0.749	0.749	1.000	1.000	0.582
3	0.890	0.976	0.930	0.905	1.000	1.000	0.940	0.940	1.000	1.000	0.885
4	0.818	0.947	0.887	0.902	1.000	1.000	0.939	0.939	1.000	1.000	0.808
5	0.870	0.837	0.940	1.000	1.000	1.000	1.000	1.000	1.000	1.000	0.870
6	0.875	0.965	0.919	0.951	1.000	1.000	0.969	0.969	1.000	1.000	0.871
7	0.785	0.849	0.875	1.000	1.000	1.000	1.000	1.000	1.000	1.000	0.786

POSITIVE NUMBER: CONSTRAINT SATISFIED. | THESE VALUES ARE NORMALIZED
 NEGATIVE NUMBER: CONSTRAINT VIOLATED. | BETWEEN +1. AND -1.
 1.000 : CONSTRAINT NOT RELEASED OR NULLIFIED BY USER.
 -2.000 : CONSTRAINT SUPPRESSED.
 -- : STRAKE NOT EVALUATED.

Analytical Transverse Hogging

INITIAL FRAME ADEQUACY PARAMETER VALUES - MODULE 1 OF SUBSTR. 1

STRAKE	FCPH1	FCPH2	FCPH3	FYCF1	FYCF2	FYCF3	FYTF1	FYTF2	FYTF3	FYCP1	FYCP2	FYCP3	FYTP1	FYTP2	FYTP3
1	0.927	0.794	0.907	0.907	1.000	1.000	1.000	0.693	0.839	0.980	0.922	0.960	0.948	1.000	1.000
2	0.747	0.794	0.966	0.695	1.000	1.000	1.000	0.667	0.948	1.000	0.939	0.975	0.899	1.000	0.967
3	0.871	0.885	0.991	0.806	1.000	0.980	1.000	0.806	1.000	1.000	0.968	1.000	0.958	1.000	0.979
4	0.978	0.935	0.975	0.965	1.000	1.000	0.959	0.894	0.953	0.984	0.976	0.982	0.986	1.000	1.000
5	0.945	0.974	0.964	0.921	0.955	0.940	1.000	1.000	1.000	1.000	1.000	1.000	0.957	0.959	0.958
6	0.869	0.877	0.995	1.000	0.807	1.000	0.791	1.000	0.977	0.957	1.000	0.979	1.000	0.961	1.000
7	0.862	0.900	0.954	0.783	1.000	0.874	1.000	0.816	1.000	1.000	0.875	1.000	0.874	1.000	0.876

MAESTRO Transverse Hogging

INITIAL FRAME ADEQUACY PARAMETER VALUES - MODULE 1 OF SUBSTR. 1

STRAKE	FCPH1	FCPH2	FCPH3	FYCF1	FYCF2	FYCF3	FYTF1	FYTF2	FYTF3	FYCP1	FYCP2	FYCP3	FYTP1	FYTP2	FYTP3
1	0.919	0.867	0.950	0.906	1.000	1.000	0.976	0.783	0.887	0.982	0.947	0.965	0.941	1.000	0.981
2	0.832	0.848	0.977	0.824	1.000	1.000	1.000	0.730	0.918	1.000	0.955	0.980	0.905	1.000	0.958
3	0.933	0.952	0.990	0.912	1.000	0.989	1.000	0.925	0.991	1.000	0.988	1.000	0.974	1.000	0.989
4	0.919	0.884	0.979	0.882	1.000	1.000	1.000	0.818	0.948	1.000	0.956	0.964	0.958	1.000	1.000
5	0.944	0.978	0.966	0.921	0.952	0.940	0.988	1.000	1.000	0.987	0.952	0.988	0.951	0.980	0.952
6	0.930	0.939	0.993	1.000	0.912	1.000	0.902	1.000	0.985	0.977	0.993	0.988	1.000	0.981	1.000
7	0.863	0.883	0.965	0.783	1.000	0.868	1.000	0.794	0.874	1.000	0.866	0.868	0.866	1.000	0.895

POSITIVE NUMBER: CONSTRAINT SATISFIED. | THESE VALUES ARE NORMALIZED
 NEGATIVE NUMBER: CONSTRAINT VIOLATED. | BETWEEN +1. AND -1.
 1.000 : CONSTRAINT NOT RELEVANT OR NULLIFIED BY USER.
 -2.000 : CONSTRAINT SUPPRESSED.
 -- : STRAKE NOT EVALUATED.

Analytical Transverse Hogging

INITIAL PANEL ADEQUACY PARAMETER VALUES - MODULE 2 OF SUBSTR. 1

STRAKE	PCSF	PCCB	PCMY	PCSB	PYTF	PYTP	PYCF	PYCP	PSPBT	PSPBL	PFLB
1	0.686	0.872	0.855	0.877	0.985	0.985	0.935	0.935	1.000	1.000	0.651
2	0.806	0.951	0.846	0.861	1.000	1.000	0.912	0.912	1.000	1.000	0.801
3	0.833	0.655	0.890	0.969	1.000	1.000	0.981	0.981	1.000	1.000	0.628
4	0.879	0.862	0.919	0.985	0.981	0.981	0.991	0.991	1.000	1.000	0.802
5	0.760	0.981	0.819	1.000	1.000	1.000	1.000	1.000	1.000	1.000	0.761
6	0.731	0.503	0.834	0.960	1.000	1.000	0.976	0.976	1.000	1.000	0.433
7	0.527	0.918	0.646	1.000	1.000	1.000	1.000	1.000	1.000	1.000	0.528

MAESTRO Transverse Hogging

INITIAL PANEL ADEQUACY PARAMETER VALUES - MODULE 2 OF SUBSTR. 1

STRAKE	PCSF	PCCB	PCMY	PCSB	PYTF	PYTP	PYCF	PYCP	PSPBT	PSPBL	PFLB
1	0.604	0.860	0.814	0.823	0.978	0.978	0.905	0.905	1.000	1.000	0.570
2	0.739	0.927	0.816	0.787	1.000	1.000	0.863	0.863	1.000	1.000	0.740
3	0.807	0.590	0.870	0.956	1.000	1.000	0.971	0.971	1.000	1.000	0.561
4	0.850	0.835	0.902	0.964	0.973	0.973	0.979	0.979	1.000	1.000	0.773
5	0.692	0.955	0.763	1.000	1.000	1.000	1.000	1.000	1.000	1.000	0.693
6	0.669	0.397	0.788	0.945	1.000	1.000	0.966	0.966	1.000	1.000	0.308
7	0.658	0.894	0.744	1.000	1.000	1.000	1.000	1.000	1.000	1.000	0.659

POSITIVE NUMBER: CONSTRAINT SATISFIED. | THESE VALUES ARE NORMALIZED
 NEGATIVE NUMBER: CONSTRAINT VIOLATED. | BETWEEN +1. AND -1.
 1.000 : CONSTRAINT NOT RELEVANT OR NULLIFIED BY USER.
 -2.000 : CONSTRAINT SUPPRESSED.
 -- : STRAKE NOT EVALUATED.

Analytical Transverse Hogging

INITIAL FRAME ADEQUACY PARAMETER VALUES - MODULE 2 OF SUBSTR. 1

STRAKE	FCPH1	FCPH2	FCPH3	FYCF1	FYCF2	FYCF3	FYTF1	FYTF2	FYTF3	FYCP1	FYCP2	FYCP3	FYTP1	FYTP2	FYTP3
1	0.946	0.986	0.978	0.950	1.000	0.988	1.000	0.961	0.992	0.993	0.983	0.988	0.960	0.979	0.970
2	0.933	0.935	0.997	0.917	1.000	1.000	0.977	0.862	0.918	1.000	0.982	0.992	0.904	0.919	0.912
3	0.900	0.912	0.993	0.845	0.954	0.899	1.000	0.860	1.000	0.909	0.895	0.902	0.977	1.000	1.000
4	0.978	0.947	0.984	0.952	0.969	0.963	1.000	0.919	0.974	0.959	0.958	0.958	0.984	1.000	1.000
5	0.948	0.984	0.982	0.952	0.962	0.959	0.918	0.859	0.891	0.995	0.980	0.980	0.827	0.845	0.836
6	0.897	0.905	0.991	0.941	0.835	0.886	0.842	1.000	0.985	0.860	0.874	0.867	1.000	0.979	1.000
7	0.880	0.918	0.976	0.806	1.000	0.888	0.839	0.723	0.779	0.899	0.881	0.890	0.773	0.789	0.781

MAESTRO Transverse Hogging

INITIAL FRAME ADEQUACY PARAMETER VALUES - MODULE 2 OF SUBSTR. 1

STRAKE	FCPH1	FCPH2	FCPH3	FYCF1	FYCF2	FYCF3	FYTF1	FYTF2	FYTF3	FYCP1	FYCP2	FYCP3	FYTP1	FYTP2	FYTP3
1	0.934	0.985	0.974	0.946	1.000	0.984	1.000	0.943	0.986	0.991	0.980	0.986	0.943	0.968	0.956
2	0.942	0.945	0.997	0.944	1.000	1.000	0.974	0.855	0.913	1.000	0.986	0.994	0.900	0.915	0.907
3	0.942	0.958	0.991	0.836	0.917	0.875	1.000	0.929	1.000	0.888	0.877	0.882	0.987	1.000	0.993
4	0.926	0.893	0.982	0.870	1.000	0.958	1.000	0.832	0.954	0.951	0.940	0.945	0.960	1.000	1.000
5	0.943	0.987	0.978	0.953	0.958	0.956	0.891	0.822	0.857	0.993	0.979	0.993	0.782	0.799	0.790
6	0.940	0.955	0.990	0.900	0.804	0.851	0.913	1.000	0.988	0.824	0.836	0.830	1.000	0.989	1.000
7	0.871	0.886	0.983	0.776	1.000	0.871	0.910	0.760	0.839	0.880	0.860	0.871	0.804	0.827	0.815

POSITIVE NUMBER: CONSTRAINT SATISFIED. | THESE VALUES ARE NORMALIZED
 NEGATIVE NUMBER: CONSTRAINT VIOLATED. | BETWEEN +1. AND -1.
 1.000 : CONSTRAINT NOT RELEVANT OR NULLIFIED BY USER.
 -2.000 : CONSTRAINT SUPPRESSED.
 -- : STRAKE NOT EVALUATED.

Analytical Transverse Hogging

INITIAL PANEL ADEQUACY PARAMETER VALUES - MODULE 1 OF SUBSTR. 2

STRAKE	PCSF	PCCB	PCMY	PCSB	PYTF	PYTP	PYCF	PYCP	PSPBT	PSPBL	PFLB
1	0.750	0.949	0.884	0.874	1.000	1.000	0.883	0.883	1.000	1.000	0.749
2	0.240	0.729	0.635	0.325	1.000	1.000	0.693	0.693	1.000	1.000	0.237
3	0.266	0.387	0.677	0.638	1.000	1.000	0.807	0.807	1.000	1.000	0.210
5	0.376	0.276	0.697	1.000	1.000	1.000	1.000	1.000	1.000	1.000	0.376
6	0.786	0.946	0.937	0.930	0.983	0.983	0.935	0.935	1.000	1.000	0.703

MAESTRO Transverse Hogging

INITIAL PANEL ADEQUACY PARAMETER VALUES - MODULE 1 OF SUBSTR. 2

STRAKE	PCSF	PCCB	PCMY	PCSB	PYTF	PYTP	PYCF	PYCP	PSPBT	PSPBL	PFLB
1	0.664	0.937	0.853	0.846	1.000	1.000	0.857	0.857	1.000	1.000	0.655
2	-0.007	0.575	0.451	0.120	1.000	1.000	0.543	0.543	1.000	1.000	-0.010
3	0.017	0.226	0.625	0.444	1.000	1.000	0.686	0.686	1.000	1.000	-0.024
5	0.381	0.277	0.681	1.000	1.000	1.000	1.000	1.000	1.000	1.000	0.381
6	0.733	0.928	0.934	0.930	0.979	0.979	0.935	0.935	1.000	1.000	0.630

POSITIVE NUMBER: CONSTRAINT SATISFIED. | THESE VALUES ARE NORMALIZED
 NEGATIVE NUMBER: CONSTRAINT VIOLATED. | BETWEEN +1. AND -1.
 1.000 : CONSTRAINT NOT RELEVANT OR NULLIFIED BY USER.
 -2.000 : CONSTRAINT SUPPRESSED.
 -- : STRAKE NOT EVALUATED.

Analytical Transverse Hogging

INITIAL FRAME ADEQUACY PARAMETER VALUES - MODULE 1 OF SUBSTR. 2

STRAKE	FCPH1	FCPH2	FCPH3	FYCF1	FYCF2	FYCF3	FYTF1	FYTF2	FYTF3	FYCP1	FYCP2	FYCP3	FYTP1	FYTP2	FYTP3
1	0.812	0.791	0.987	1.000	0.621	0.821	0.690	1.000	0.986	0.822	1.000	0.828	0.990	0.825	0.981
2	0.721	0.751	0.975	0.623	1.000	1.000	1.000	0.488	0.748	1.000	0.770	1.000	0.754	0.902	0.767
3	0.778	0.921	0.863	0.853	0.918	0.964	0.902	0.879	0.968	0.948	0.974	0.962	0.721	0.811	0.765
5	0.846	0.975	0.918	0.931	0.954	0.943	0.616	0.751	0.683	0.951	0.946	0.949	0.807	0.757	0.783
6	0.812	0.779	0.980	0.663	1.000	0.934	1.000	0.627	0.820	0.976	0.817	0.822	0.819	1.000	1.000

MAESTRO Transverse Hogging

INITIAL FRAME ADEQUACY PARAMETER VALUES - MODULE 1 OF SUBSTR. 2

STRAKE	FCPH1	FCPH2	FCPH3	FYCF1	FYCF2	FYCF3	FYTF1	FYTF2	FYTF3	FYCP1	FYCP2	FYCP3	FYTP1	FYTP2	FYTP3
1	0.820	0.803	0.979	1.000	0.649	0.833	0.694	1.000	0.965	0.830	1.000	0.836	0.954	0.834	0.950
2	0.718	0.760	0.967	0.626	1.000	1.000	1.000	0.494	0.752	1.000	0.763	0.772	0.771	0.874	0.824
3	0.672	0.935	0.794	0.748	0.966	0.921	0.890	0.849	0.938	0.934	0.957	0.945	0.621	0.748	0.682
5	0.725	0.971	0.854	0.946	0.956	0.954	0.448	0.650	0.551	0.955	0.951	0.953	0.702	0.647	0.680
6	0.819	0.795	0.986	0.685	1.000	0.972	1.000	0.644	0.830	0.969	0.826	0.832	0.831	1.000	1.000

Analytical Transverse Hogging

INITIAL PANEL ADEQUACY PARAMETER VALUES - MODULE 2 OF SUBSTR. 2

STRAKE	PCSF	PCCB	PCMY	PCSB	PYTF	PYTP	PYCF	PYCP	PSPBT	PSPBL	PFLB
1	0.488	0.747	0.839	0.745	1.000	1.000	0.862	0.862	1.000	1.000	0.469
2	0.510	0.885	0.692	0.603	1.000	1.000	0.729	0.729	1.000	1.000	0.499
3	0.875	0.981	0.941	0.924	1.000	1.000	0.951	0.951	1.000	1.000	0.874
4	0.841	0.966	0.930	0.874	1.000	1.000	0.954	0.954	1.000	1.000	0.844
5	0.845	0.847	0.870	1.000	1.000	1.000	1.000	1.000	1.000	1.000	0.832
6	0.895	0.969	0.945	0.970	0.987	0.987	0.981	0.981	1.000	1.000	0.829
7	0.776	0.868	0.816	1.000	1.000	1.000	1.000	1.000	1.000	1.000	0.777

MAESTRO Transverse Hogging

INITIAL PANEL ADEQUACY PARAMETER VALUES - MODULE 2 OF SUBSTR. 2

STRAKE	PCSF	PCCB	PCMY	PCSB	PYTF	PYTP	PYCF	PYCP	PSPBT	PSPBL	PFLB
1	0.325	0.648	0.775	0.637	1.000	1.000	0.797	0.797	1.000	1.000	0.290
2	0.299	0.821	0.555	0.448	1.000	1.000	0.611	0.611	1.000	1.000	0.285
3	0.807	0.969	0.905	0.876	1.000	1.000	0.919	0.919	1.000	1.000	0.807
4	0.725	0.936	0.874	0.783	1.000	1.000	0.919	0.919	1.000	1.000	0.730
5	0.795	0.725	0.850	1.000	1.000	1.000	1.000	1.000	1.000	1.000	0.795
6	0.848	0.934	0.911	0.943	0.994	0.994	0.963	0.963	1.000	1.000	0.809
7	0.790	0.767	0.816	1.000	1.000	1.000	1.000	1.000	1.000	1.000	0.790

POSITIVE NUMBER: CONSTRAINT SATISFIED. | THESE VALUES ARE NORMALIZED
 NEGATIVE NUMBER: CONSTRAINT VIOLATED. | BETWEEN +1. AND -1.
 1.000 : CONSTRAINT NOT RELEVANT OR NULLIFIED BY USER.
 -2.000 : CONSTRAINT SUPPRESSED.
 --- : STRAKE NOT EVALUATED.

Analytical Transverse Hogging

INITIAL FRAME ADEQUACY PARAMETER VALUES - MODULE 2 OF SUBSTR. 2

STRAKE	FCPH1	FCPH2	FCPH3	FYCF1	FYCF2	FYCF3	FYTF1	FYTF2	FYTF3	FYCP1	FYCP2	FYCP3	FYTP1	FYTP2	FYTP3
1	0.923	0.930	0.927	0.921	0.930	0.925	0.935	0.918	0.927	0.970	0.965	0.967	0.932	0.936	0.934
2	0.871	0.888	0.983	0.880	1.000	1.000	1.000	0.751	0.906	1.000	0.977	1.000	0.894	0.949	0.921
3	0.860	0.868	0.994	0.827	1.000	1.000	1.000	0.793	0.972	1.000	0.977	1.000	0.932	1.000	0.967
4	0.839	0.840	0.974	1.000	0.450	0.483	0.461	1.000	0.757	0.483	1.000	1.000	1.000	0.483	0.483
5	0.968	0.980	0.985	0.962	0.960	0.963	0.943	0.906	0.925	0.975	0.976	0.975	0.882	0.891	0.886
6	0.856	0.855	0.993	1.000	0.798	0.979	0.800	1.000	0.981	0.953	0.989	0.978	1.000	0.954	1.000
7	0.924	0.939	0.932	0.901	0.976	0.943	0.914	0.917	0.927	0.944	0.940	0.943	0.948	0.974	0.978

MAESTRO Transverse Hogging

INITIAL FRAME ADEQUACY PARAMETER VALUES - MODULE 2 OF SUBSTR. 2

STRAKE	FCPH1	FCPH2	FCPH3	FYCF1	FYCF2	FYCF3	FYTF1	FYTF2	FYTF3	FYCP1	FYCP2	FYCP3	FYTP1	FYTP2	FYTP3
1	0.896	0.881	0.888	0.896	0.876	0.886	0.919	0.907	0.913	0.956	0.951	0.951	0.904	0.895	0.900
2	0.880	0.919	0.979	0.951	1.000	1.000	0.940	0.736	0.855	1.000	0.984	1.000	0.861	0.893	0.877
3	0.928	0.936	0.991	0.917	1.000	1.000	1.000	0.864	0.964	1.000	1.000	1.000	0.943	0.970	0.956
4	0.838	0.802	0.962	1.000	0.399	0.440	0.425	0.892	0.918	0.441	1.000	1.000	0.939	0.441	0.442
5	0.961	0.986	0.982	0.961	0.951	0.956	0.919	0.873	0.896	0.960	0.962	0.961	0.851	0.862	0.857
6	0.944	0.942	0.993	1.000	0.919	0.991	0.919	1.000	0.987	0.969	0.985	0.977	1.000	0.981	0.992
7	0.908	0.943	0.936	0.923	0.929	0.958	0.885	0.946	0.922	0.953	0.955	0.955	0.972	0.964	0.969

POSITIVE NUMBER: CONSTRAINT SATISFIED. | THESE VALUES ARE NORMALIZED
 NEGATIVE NUMBER: CONSTRAINT VIOLATED. | BETWEEN +1. AND -1.
 1.000 : CONSTRAINT NOT RELEVANT OR NULLIFIED BY USER.
 -2.000 : CONSTRAINT SUPPRESSED.
 -- : STRAKE NOT EVALUATED.

Analytical Transverse Hogging

INITIAL PANEL ADEQUACY PARAMETER VALUES - MODULE 3 OF SUBSTR. 2

STRAKE	PCSF	PCCB	PCMY	PCSB	PYTF	PYTP	PYCF	PYCP	PSPBT	PSPBL	PFLB
1	0.530	0.824	0.855	0.745	1.000	1.000	0.862	0.862	1.000	1.000	0.514
2	0.619	0.893	0.765	0.657	1.000	1.000	0.768	0.768	1.000	1.000	0.619
3	0.904	0.980	0.940	0.919	1.000	1.000	0.949	0.949	1.000	1.000	0.902
4	0.865	0.979	0.917	0.919	1.000	1.000	0.949	0.949	1.000	1.000	0.861
5	0.879	0.847	0.952	1.000	1.000	1.000	1.000	1.000	1.000	1.000	0.879
6	0.913	0.973	0.946	0.961	1.000	1.000	0.976	0.976	1.000	1.000	0.884
7	0.830	0.844	0.907	1.000	1.000	1.000	1.000	1.000	1.000	1.000	0.830

MAESTRO Transverse Hogging

INITIAL PANEL ADEQUACY PARAMETER VALUES - MODULE 3 OF SUBSTR. 2

STRAKE	PCSF	PCCB	PCMY	PCSB	PYTF	PYTP	PYCF	PYCP	PSPBT	PSPBL	PFLB
1	0.373	0.764	0.773	0.637	1.000	1.000	0.797	0.797	1.000	1.000	0.348
2	0.444	0.845	0.653	0.516	1.000	1.000	0.663	0.663	1.000	1.000	0.442
3	0.851	0.967	0.904	0.870	1.000	1.000	0.918	0.918	1.000	1.000	0.848
4	0.800	0.964	0.875	0.869	1.000	1.000	0.916	0.916	1.000	1.000	0.794
5	0.808	0.722	0.932	1.000	1.000	1.000	1.000	1.000	1.000	1.000	0.808
6	0.856	0.958	0.911	0.932	1.000	1.000	0.958	0.958	1.000	1.000	0.847
7	0.756	0.768	0.870	1.000	1.000	1.000	1.000	1.000	1.000	1.000	0.757

POSITIVE NUMBER: CONSTRAINT SATISFIED. | THESE VALUES ARE NORMALIZED
 NEGATIVE NUMBER: CONSTRAINT VIOLATED. | BETWEEN +1. AND -1.
 1.000 : CONSTRAINT NOT RELEVANT OR NULLIFIED BY USER.
 -2.000 : CONSTRAINT SUPPRESSED.
 -- : STRAKE NOT EVALUATED.

Analytical Transverse Hogging

INITIAL FRAME ADEQUACY PARAMETER VALUES - MODULE 3 OF SUBSTR. 2

STRAKE	FCPH1	FCPH2	FCPH3	FYCF1	FYCF2	FYCF3	FYTF1	FYTF2	FYTF3	FYCP1	FYCP2	FYCP3	FYTP1	FYTP2	FYTP3
1	0.929	0.925	0.934	0.922	0.932	0.944	1.000	0.882	0.947	0.987	0.972	0.980	0.950	0.944	0.947
2	0.870	0.840	0.983	0.859	1.000	1.000	1.000	0.741	0.928	1.000	0.976	0.989	0.916	0.985	0.955
3	0.845	0.850	0.994	0.795	1.000	1.000	1.000	0.780	0.976	1.000	0.963	1.000	0.938	1.000	0.974
4	0.909	0.819	0.949	1.000	0.759	0.928	0.852	1.000	0.954	0.954	1.000	1.000	1.000	0.919	0.947
5	0.973	0.986	0.984	0.954	0.969	0.966	0.964	1.000	0.972	0.972	0.974	0.975	1.000	0.969	0.971
6	0.841	0.841	0.994	1.000	0.782	1.000	0.776	1.000	0.976	0.952	1.000	0.978	1.000	0.945	0.977
7	0.906	0.899	0.978	0.840	1.000	0.971	1.000	0.826	0.898	1.000	0.896	0.899	0.899	0.978	0.975

MAESTRO Transverse Hogging

INITIAL FRAME ADEQUACY PARAMETER VALUES - MODULE 3 OF SUBSTR. 2

STRAKE	FCPH1	FCPH2	FCPH3	FYCF1	FYCF2	FYCF3	FYTF1	FYTF2	FYTF3	FYCP1	FYCP2	FYCP3	FYTP1	FYTP2	FYTP3
1	0.927	0.825	0.889	0.933	0.813	0.900	0.992	0.904	0.950	0.981	0.970	0.976	0.937	0.895	0.916
2	0.872	0.812	0.965	0.890	1.000	1.000	0.939	0.682	0.876	1.000	0.979	0.990	0.888	0.972	0.930
3	0.938	0.940	0.993	0.930	1.000	1.000	1.000	0.898	0.972	1.000	0.991	1.000	0.963	0.991	0.979
4	0.961	0.815	0.921	0.995	0.763	0.906	0.913	0.938	0.965	1.000	1.000	1.000	0.960	0.913	0.940
5	0.960	0.995	0.981	0.960	0.991	0.970	0.924	0.953	0.944	0.951	0.969	0.953	1.000	0.952	1.000
6	0.937	0.937	0.993	1.000	0.916	1.000	0.905	1.000	0.983	0.982	0.994	0.989	1.000	0.975	0.990
7	0.934	0.918	0.984	0.886	0.967	1.000	0.963	0.855	0.918	0.939	0.917	0.920	0.921	0.972	0.976

POSITIVE NUMBER: CONSTRAINT SATISFIED. | THESE VALUES ARE NORMALIZED
 NEGATIVE NUMBER: CONSTRAINT VIOLATED. | BETWEEN +1. AND -1.
 1.000 : CONSTRAINT NOT RELEVANT OR NULLIFIED BY USER.
 -2.000 : CONSTRAINT SUPPRESSED.
 -- : STRAKE NOT EVALUATED.

Appendix J. Comparison of Results for Transverse Sagging

Analytical Transverse Sagging

INITIAL PANEL ADEQUACY PARAMETER VALUES - MODULE 1 OF SUBSTR. 1

STRAKE	PCSF	PCCB	PCMY	PCSB	PYTF	PYTP	PYCF	PYCP	PSPBT	PSPBL	PFLB
1	0.655	0.859	0.864	0.824	1.000	1.000	0.906	0.906	1.000	1.000	0.624
2	0.719	0.915	0.843	0.758	1.000	1.000	0.842	0.842	1.000	1.000	0.718
3	0.932	0.986	0.957	0.943	1.000	1.000	0.964	0.964	1.000	1.000	0.929
4	0.879	0.975	0.924	0.937	1.000	1.000	0.962	0.962	1.000	1.000	0.874
5	0.862	0.791	0.954	1.000	1.000	1.000	1.000	1.000	1.000	1.000	0.862
6	0.913	0.974	0.946	0.968	1.000	1.000	0.980	0.980	1.000	1.000	0.908
7	0.835	0.877	0.908	1.000	1.000	1.000	1.000	1.000	1.000	1.000	0.835

MAESTRO Transverse Sagging

INITIAL PANEL ADEQUACY PARAMETER VALUES - MODULE 1 OF SUBSTR. 1

STRAKE	PCSF	PCCB	PCMY	PCSB	PYTF	PYTP	PYCF	PYCP	PSPBT	PSPBL	PFLB
1	0.458	0.819	0.773	0.707	1.000	1.000	0.839	0.839	1.000	1.000	0.435
2	0.541	0.842	0.730	0.594	1.000	1.000	0.727	0.727	1.000	1.000	0.540
3	0.879	0.970	0.924	0.897	1.000	1.000	0.934	0.934	1.000	1.000	0.872
4	0.808	0.949	0.882	0.891	1.000	1.000	0.933	0.933	1.000	1.000	0.798
5	0.859	0.835	0.923	1.000	1.000	1.000	1.000	1.000	1.000	1.000	0.859
6	0.861	0.962	0.910	0.945	1.000	1.000	0.965	0.965	1.000	1.000	0.855
7	0.781	0.828	0.877	1.000	1.000	1.000	1.000	1.000	1.000	1.000	0.782

POSITIVE NUMBER: CONSTRAINT SATISFIED. | THESE VALUES ARE NORMALIZED
 NEGATIVE NUMBER: CONSTRAINT VIOLATED. | BETWEEN +1. AND -1.
 1.000 : CONSTRAINT NOT RELEVANT OR NULLIFIED BY USER.
 -2.000 : CONSTRAINT SUPPRESSED.

Analytical Transverse Sagging

INITIAL FRAME ADEQUACY PARAMETER VALUES - MODULE 1 OF SUBSTR. 1

STRAKE	FCPH1	FCPH2	FCPH3	FYCF1	FYCF2	FYCF3	FYTF1	FYTF2	FYTF3	FYCP1	FYCP2	FYCP3	FYTP1	FYTP2	FYTP3
1	0.986	0.976	0.989	0.990	0.985	1.000	0.959	0.980	0.976	0.981	0.987	0.984	0.988	0.995	0.992
2	0.965	0.978	0.983	1.000	1.000	1.000	0.898	0.931	0.936	0.984	0.991	0.990	0.970	0.983	0.976
3	0.956	0.950	0.995	1.000	0.928	0.994	0.918	1.000	0.991	0.989	1.000	1.000	1.000	0.984	0.992
4	0.896	0.878	0.989	0.852	1.000	1.000	1.000	0.813	0.954	1.000	0.951	0.960	0.950	1.000	0.963
5	0.971	0.981	0.977	1.000	1.000	1.000	0.960	0.972	0.967	0.977	0.979	0.979	1.000	1.000	1.000
6	0.957	0.950	0.996	0.929	1.000	1.000	1.000	0.918	0.990	1.000	0.981	0.989	0.989	1.000	1.000
7	0.929	0.930	0.996	0.883	1.000	0.934	1.000	0.879	0.927	1.000	0.925	0.927	0.926	1.000	1.000

MAESTRO Transverse Sagging

INITIAL FRAME ADEQUACY PARAMETER VALUES - MODULE 1 OF SUBSTR. 1

STRAKE	FCPH1	FCPH2	FCPH3	FYCF1	FYCF2	FYCF3	FYTF1	FYTF2	FYTF3	FYCP1	FYCP2	FYCP3	FYTP1	FYTP2	FYTP3
1	0.847	0.946	0.931	0.828	1.000	0.944	1.000	0.890	1.000	0.991	0.967	0.981	0.920	1.000	0.960
2	0.927	0.923	0.986	0.961	1.000	1.000	0.885	0.826	0.886	0.983	0.977	0.983	0.932	0.983	0.957
3	0.935	0.924	0.991	1.000	0.892	0.990	0.881	1.000	0.987	0.981	1.000	0.989	1.000	0.981	0.991
4	0.833	0.825	0.993	0.768	1.000	0.955	1.000	0.744	0.939	1.000	0.925	0.940	0.922	1.000	0.943
5	0.891	0.952	0.922	0.851	0.913	0.884	1.000	1.000	1.000	1.000	0.978	1.000	0.927	0.930	0.929
6	0.941	0.935	0.994	0.910	1.000	1.000	1.000	0.891	0.986	1.000	0.977	0.986	0.985	1.000	1.000
7	0.864	0.901	0.965	0.795	1.000	0.878	1.000	0.820	1.000	1.000	0.877	0.879	0.878	1.000	0.897

POSITIVE NUMBER: CONSTRAINT SATISFIED. | THESE VALUES ARE NORMALIZED
 NEGATIVE NUMBER: CONSTRAINT VIOLATED. | BETWEEN +1. AND -1.
 1.000 : CONSTRAINT NOT RELEVANT OR NULLIFIED BY USER.
 -2.000 : CONSTRAINT SUPPRESSED.
 -- : STRAKE NOT EVALUATED.

Analytical Transverse Sagging

INITIAL PANEL ADEQUACY PARAMETER VALUES - MODULE 2 OF SUBSTR. 1

STRAKE	PCSF	PCCB	PCMY	PCSB	PYTF	PYTP	PYCF	PYCP	PSPBT	PSPBL	PFLB
1	0.773	0.915	0.910	0.903	0.989	0.989	0.949	0.949	1.000	1.000	0.748
2	0.857	0.962	0.920	0.872	1.000	1.000	0.919	0.919	1.000	1.000	0.856
3	0.904	0.798	0.939	0.979	1.000	1.000	0.986	0.986	1.000	1.000	0.780
4	0.914	0.934	0.945	0.978	0.985	0.985	0.988	0.988	1.000	1.000	0.889
5	0.882	0.887	0.912	1.000	1.000	1.000	1.000	1.000	1.000	1.000	0.882
6	0.829	0.670	0.894	0.971	1.000	1.000	0.983	0.983	1.000	1.000	0.598
7	0.749	0.659	0.877	1.000	1.000	1.000	1.000	1.000	1.000	1.000	0.749

MAESTRO Transverse Sagging

INITIAL PANEL ADEQUACY PARAMETER VALUES - MODULE 2 OF SUBSTR. 1

STRAKE	PCSF	PCCB	PCMY	PCSB	PYTF	PYTP	PYCF	PYCP	PSPBT	PSPBL	PFLB
1	0.618	0.925	0.789	0.817	0.973	0.973	0.902	0.902	1.000	1.000	0.596
2	0.740	0.927	0.826	0.768	1.000	1.000	0.850	0.850	1.000	1.000	0.741
3	0.811	0.607	0.875	0.954	1.000	1.000	0.970	0.970	1.000	1.000	0.582
4	0.852	0.844	0.911	0.955	0.965	0.965	0.974	0.974	1.000	1.000	0.759
5	0.605	0.940	0.689	1.000	1.000	1.000	1.000	1.000	1.000	1.000	0.606
6	0.670	0.391	0.783	0.938	1.000	1.000	0.962	0.962	1.000	1.000	0.296
7	0.442	0.288	0.712	1.000	1.000	1.000	1.000	1.000	1.000	1.000	0.443

POSITIVE NUMBER: CONSTRAINT SATISFIED. | THESE VALUES ARE NORMALIZED
 NEGATIVE NUMBER: CONSTRAINT VIOLATED. | BETWEEN +1. AND -1.
 1.000 : CONSTRAINT NOT RELEVANT OR NULLIFIED BY USER.
 -2.000 : CONSTRAINT SUPPRESSED.
 -- : STRAKE NOT EVALUATED.

Analytical Transverse Sagging

INITIAL FRAME ADEQUACY PARAMETER VALUES - MODULE 2 OF SUBSTR. 1

STRAKE	FCPH1	FCPH2	FCPH3	FYCF1	FYCF2	FYCF3	FYTF1	FYTF2	FYTF3	FYCP1	FYCP2	FYCP3	FYTP1	FYTP2	FYTP3
1	0.976	0.993	0.991	0.980	1.000	0.996	0.991	0.978	0.993	0.991	0.990	0.991	0.980	0.989	0.985
2	0.983	0.987	0.998	0.995	1.000	1.000	0.984	0.953	0.972	1.000	0.999	0.999	0.968	0.973	0.970
3	0.977	0.968	0.995	0.946	0.941	0.943	0.959	1.000	1.000	0.948	0.949	0.949	1.000	0.991	0.996
4	0.908	0.887	0.987	0.854	1.000	0.968	1.000	0.819	0.954	0.978	0.952	0.959	0.955	1.000	1.000
5	0.978	0.985	0.982	0.996	0.993	0.994	0.965	0.955	0.960	0.982	0.984	0.983	0.926	0.928	0.927
6	0.976	0.967	0.995	0.940	0.909	0.925	1.000	0.951	0.992	0.917	0.921	0.919	0.996	1.000	1.000
7	0.922	0.912	0.968	0.857	0.955	0.912	1.000	0.854	0.912	0.979	0.910	0.912	0.910	1.000	0.912

MAESTRO Transverse Sagging

INITIAL FRAME ADEQUACY PARAMETER VALUES - MODULE 2 OF SUBSTR. 1

STRAKE	FCPH1	FCPH2	FCPH3	FYCF1	FYCF2	FYCF3	FYTF1	FYTF2	FYTF3	FYCP1	FYCP2	FYCP3	FYTP1	FYTP2	FYTP3
1	0.923	0.986	0.963	0.906	1.000	0.955	1.000	0.927	0.979	1.000	0.977	0.985	0.927	0.953	0.940
2	0.957	0.961	0.998	0.976	1.000	1.000	0.975	0.881	0.927	1.000	0.994	0.997	0.918	0.929	0.923
3	0.980	0.965	0.990	0.877	0.879	0.878	0.964	1.000	1.000	0.891	0.890	0.891	1.000	0.994	0.997
4	0.851	0.830	0.986	0.748	1.000	0.929	1.000	0.742	0.927	0.945	0.915	0.927	0.923	1.000	1.000
5	0.948	0.960	0.954	0.913	0.927	0.920	0.828	0.767	0.797	1.000	0.986	0.986	0.728	0.743	0.736
6	0.977	0.970	0.991	0.864	0.827	0.845	0.975	0.957	0.987	0.822	0.827	0.825	1.000	1.000	1.000
7	0.835	0.885	0.971	0.710	1.000	0.833	1.000	0.798	1.000	0.890	0.851	0.867	0.846	1.000	0.851

POSITIVE NUMBER: CONSTRAINT SATISFIED. | THESE VALUES ARE NORMALIZED
 NEGATIVE NUMBER: CONSTRAINT VIOLATED. | BETWEEN +1. AND -1.
 1.000 : CONSTRAINT NOT RELEVANT OR NULLIFIED BY USER.
 -2.000 : CONSTRAINT SUPPRESSED.
 -- : STRAKE NOT EVALUATED.

Analytical Transverse Sagging

INITIAL PANEL ADEQUACY PARAMETER VALUES - MODULE 1 OF SUBSTR. 2

STRAKE	PCSF	PCCB	PCMY	PCSB	PYTF	PYTP	PYCF	PYCP	PSPBT	PSPBL	PFLB
1	0.780	0.966	0.910	0.912	1.000	1.000	0.919	0.919	1.000	1.000	0.772
2	0.213	0.721	0.600	0.340	1.000	1.000	0.678	0.678	1.000	1.000	0.206
3	0.217	0.435	0.767	0.592	1.000	1.000	0.779	0.779	1.000	1.000	0.187
5	0.651	0.566	0.828	1.000	1.000	1.000	1.000	1.000	1.000	1.000	0.651
6	0.834	0.965	0.964	0.968	0.986	0.986	0.970	0.970	1.000	1.000	0.770

MAESTRO Transverse Sagging

INITIAL PANEL ADEQUACY PARAMETER VALUES - MODULE 1 OF SUBSTR. 2

STRAKE	PCSF	PCCB	PCMY	PCSB	PYTF	PYTP	PYCF	PYCP	PSPBT	PSPBL	PFLB
1	0.644	0.937	0.849	0.849	1.000	1.000	0.861	0.861	1.000	1.000	0.632
2	-0.067	0.526	0.395	0.078	1.000	1.000	0.500	0.500	1.000	1.000	-0.069
3	-0.055	0.207	0.627	0.385	1.000	1.000	0.646	0.646	1.000	1.000	-0.083
5	0.474	0.370	0.718	1.000	1.000	1.000	1.000	1.000	1.000	1.000	0.474
6	0.739	0.926	0.937	0.942	0.979	0.979	0.947	0.947	1.000	1.000	0.639

POSITIVE NUMBER: CONSTRAINT SATISFIED. | THESE VALUES ARE NORMALIZED
 NEGATIVE NUMBER: CONSTRAINT VIOLATED. | BETWEEN +1. AND -1.
 1.000 : CONSTRAINT NOT RELEVANT OR NULLIFIED BY USER.
 -2.000 : CONSTRAINT SUPPRESSED.
 -- : STRAKE NOT EVALUATED.

Analytical Transverse Sagging

INITIAL FRAME ADEQUACY PARAMETER VALUES - MODULE 1 OF SUBSTR. 2

STRAKE	FCPH1	FCPH2	FCPH3	FYCF1	FYCF2	FYCF3	FYTF1	FYTF2	FYTF3	FYCP1	FYCP2	FYCP3	FYTP1	FYTP2	FYTP3
1	0.903	0.896	0.986	1.000	0.814	0.913	0.822	0.983	0.966	0.910	1.000	0.913	0.960	0.912	0.960
2	0.851	0.880	0.977	0.795	1.000	1.000	1.000	0.724	0.874	0.883	0.867	0.877	0.864	0.925	0.894
3	0.775	0.958	0.862	0.820	1.000	0.940	0.938	0.908	0.952	0.960	0.968	0.964	0.746	0.840	0.792
5	0.803	0.982	0.899	0.976	0.974	0.979	0.602	0.759	0.686	0.978	0.977	0.978	0.786	0.755	0.776
6	0.900	0.894	0.992	0.825	0.997	0.998	1.000	0.802	0.910	0.971	0.907	0.911	0.910	1.000	1.000

MAESTRO Transverse Sagging

INITIAL FRAME ADEQUACY PARAMETER VALUES - MODULE 1 OF SUBSTR. 2

STRAKE	FCPH1	FCPH2	FCPH3	FYCF1	FYCF2	FYCF3	FYTF1	FYTF2	FYTF3	FYCP1	FYCP2	FYCP3	FYTP1	FYTP2	FYTP3
1	0.859	0.848	0.977	1.000	0.731	0.872	0.747	0.960	0.949	0.868	0.977	0.873	0.932	0.871	0.933
2	0.767	0.811	0.968	0.693	1.000	1.000	1.000	0.579	0.799	0.815	0.790	0.806	0.781	0.867	0.823
3	0.646	0.923	0.773	0.713	1.000	0.896	0.901	0.858	0.924	0.933	0.946	0.940	0.604	0.739	0.669
5	0.681	0.973	0.833	0.958	0.961	0.966	0.404	0.621	0.519	0.965	0.962	0.964	0.657	0.612	0.642
6	0.857	0.845	0.985	0.755	0.989	0.996	0.997	0.716	0.868	0.956	0.864	0.870	0.870	1.000	1.000

POSITIVE NUMBER: CONSTRAINT SATISFIED. | THESE VALUES ARE NORMALIZED
 NEGATIVE NUMBER: CONSTRAINT VIOLATED. | BETWEEN +1. AND -1.
 1.000 : CONSTRAINT NOT RELEVANT OR NULLIFIED BY USER.
 -2.000 : CONSTRAINT SUPPRESSED.
 -- : STRAKE NOT EVALUATED.

Analytical Transverse Sagging

INITIAL PANEL ADEQUACY PARAMETER VALUES - MODULE 2 OF SUBSTR. 2

STRAKE	PCSF	PCCB	PCMY	PCSB	PYTF	PYTP	PYCF	PYCP	PSPBT	PSPBL	PFLB
1	0.512	0.739	0.839	0.757	1.000	1.000	0.869	0.869	1.000	1.000	0.471
2	0.484	0.886	0.691	0.616	1.000	1.000	0.737	0.737	1.000	1.000	0.469
3	0.873	0.979	0.937	0.917	1.000	1.000	0.947	0.947	1.000	1.000	0.873
4	0.793	0.956	0.906	0.846	1.000	1.000	0.943	0.943	1.000	1.000	0.798
5	0.838	0.733	0.918	1.000	1.000	1.000	1.000	1.000	1.000	1.000	0.838
6	0.897	0.962	0.935	0.960	0.999	0.999	0.974	0.974	1.000	1.000	0.886
7	0.821	0.810	0.905	1.000	1.000	1.000	1.000	1.000	1.000	1.000	0.822

MAESTRO Transverse Sagging

INITIAL PANEL ADEQUACY PARAMETER VALUES - MODULE 2 OF SUBSTR. 2

STRAKE	PCSF	PCCB	PCMY	PCSB	PYTF	PYTP	PYCF	PYCP	PSPBT	PSPBL	PFLB
1	0.292	0.663	0.740	0.613	1.000	1.000	0.782	0.782	1.000	1.000	0.255
2	0.243	0.802	0.520	0.413	1.000	1.000	0.583	0.583	1.000	1.000	0.228
3	0.789	0.964	0.896	0.860	1.000	1.000	0.910	0.910	1.000	1.000	0.789
4	0.692	0.926	0.856	0.760	1.000	1.000	0.909	0.909	1.000	1.000	0.697
5	0.821	0.760	0.849	1.000	1.000	1.000	1.000	1.000	1.000	1.000	0.796
6	0.832	0.935	0.893	0.933	0.999	0.999	0.957	0.957	1.000	1.000	0.811
7	0.753	0.753	0.861	1.000	1.000	1.000	1.000	1.000	1.000	1.000	0.754

POSITIVE NUMBER: CONSTRAINT SATISFIED. | THESE VALUES ARE NORMALIZED
 NEGATIVE NUMBER: CONSTRAINT VIOLATED. | BETWEEN +1. AND -1.
 1.000 : CONSTRAINT NOT RELEVANT OR NULLIFIED BY USER.
 -2.000 : CONSTRAINT SUPPRESSED.
 -- : STRAKE NOT EVALUATED.

Analytical Transverse Sagging

INITIAL FRAME ADEQUACY PARAMETER VALUES - MODULE 2 OF SUBSTR. 2

STRAKE	FCPH1	FCPH2	FCPH3	FYCF1	FYCF2	FYCF3	FYTF1	FYTF2	FYTF3	FYCP1	FYCP2	FYCP3	FYTP1	FYTP2	FYTP3
1	0.954	0.919	0.936	0.955	0.907	0.931	0.954	0.949	0.951	0.967	0.967	0.967	0.957	0.937	0.947
2	0.933	0.962	0.984	0.983	1.000	1.000	0.915	0.850	0.908	1.000	0.992	1.000	0.921	0.924	0.923
3	0.972	0.968	0.994	0.983	0.983	1.000	0.934	0.938	0.975	1.000	1.000	1.000	0.979	0.963	0.971
4	0.922	0.890	0.981	0.941	0.624	0.657	0.651	0.859	0.937	0.659	1.000	1.000	0.953	0.659	0.659
5	0.959	0.995	0.977	0.979	0.961	0.976	0.945	0.922	0.936	0.947	0.958	0.953	0.911	0.918	0.914
6	0.973	0.973	0.997	0.961	0.984	0.996	0.989	0.961	0.993	0.987	0.988	0.988	0.992	1.000	0.996
7	0.946	0.966	0.971	0.959	0.950	0.972	0.929	0.984	0.959	0.967	0.970	0.969	1.000	0.973	0.979

MAESTRO Transverse Sagging

INITIAL FRAME ADEQUACY PARAMETER VALUES - MODULE 2 OF SUBSTR. 2

STRAKE	FCPH1	FCPH2	FCPH3	FYCF1	FYCF2	FYCF3	FYTF1	FYTF2	FYTF3	FYCP1	FYCP2	FYCP3	FYTP1	FYTP2	FYTP3
1	0.827	0.864	0.846	0.814	0.864	0.839	0.942	0.915	0.928	0.968	0.948	0.958	0.855	0.876	0.865
2	0.908	0.946	0.979	1.000	1.000	1.000	0.867	0.766	0.838	1.000	0.990	1.000	0.860	0.871	0.866
3	0.946	0.932	0.987	0.987	0.946	1.000	0.882	0.914	0.962	1.000	1.000	1.000	0.969	0.936	0.952
4	0.869	0.842	0.943	0.797	0.576	0.612	0.605	0.715	0.854	0.614	0.868	1.000	0.862	0.613	0.614
5	0.949	0.963	0.956	0.922	0.925	0.925	0.910	0.862	0.886	0.973	0.973	0.973	0.846	0.857	0.851
6	0.953	0.957	0.994	0.935	0.979	0.994	0.990	0.936	0.991	0.978	0.981	0.980	0.984	1.000	0.993
7	0.900	0.922	0.932	0.855	0.897	0.896	0.937	1.000	0.964	0.960	0.957	0.959	0.965	0.969	0.974

POSITIVE NUMBER: CONSTRAINT SATISFIED. | THESE VALUES ARE NORMALIZED
 NEGATIVE NUMBER: CONSTRAINT VIOLATED. | BETWEEN +1. AND -1.
 1.000 : CONSTRAINT NOT RELEVANT OR NULLIFIED BY USER.
 -2.000 : CONSTRAINT SUPPRESSED.
 -- : STRAKE NOT EVALUATED.

Analytical Transverse Sagging

INITIAL PANEL ADEQUACY PARAMETER VALUES - MODULE 3 OF SUBSTR. 2

STRAKE	PCSF	PCCB	PCMY	PCSB	PYTF	PYTP	PYCF	PYCP	PSPBT	PSPBL	PFLB
1	0.556	0.807	0.841	0.758	1.000	1.000	0.869	0.869	1.000	1.000	0.524
2	0.610	0.908	0.769	0.674	1.000	1.000	0.779	0.779	1.000	1.000	0.605
3	0.906	0.979	0.937	0.915	1.000	1.000	0.947	0.947	1.000	1.000	0.904
4	0.859	0.977	0.911	0.915	1.000	1.000	0.945	0.945	1.000	1.000	0.854
5	0.836	0.732	0.953	1.000	1.000	1.000	1.000	1.000	1.000	1.000	0.837
6	0.895	0.968	0.937	0.954	1.000	1.000	0.971	0.971	1.000	1.000	0.888
7	0.815	0.823	0.902	1.000	1.000	1.000	1.000	1.000	1.000	1.000	0.815

MAESTRO Transverse Sagging

INITIAL PANEL ADEQUACY PARAMETER VALUES - MODULE 3 OF SUBSTR. 2

STRAKE	PCSF	PCCB	PCMY	PCSB	PYTF	PYTP	PYCF	PYCP	PSPBT	PSPBL	PFLB
1	0.335	0.780	0.735	0.613	1.000	1.000	0.782	0.782	1.000	1.000	0.308
2	0.398	0.833	0.622	0.482	1.000	1.000	0.636	0.636	1.000	1.000	0.394
3	0.837	0.963	0.896	0.857	1.000	1.000	0.910	0.910	1.000	1.000	0.834
4	0.779	0.959	0.853	0.853	1.000	1.000	0.906	0.906	1.000	1.000	0.773
5	0.818	0.729	0.916	1.000	1.000	1.000	1.000	1.000	1.000	1.000	0.818
6	0.831	0.959	0.895	0.923	1.000	1.000	0.952	0.952	1.000	1.000	0.821
7	0.734	0.751	0.860	1.000	1.000	1.000	1.000	1.000	1.000	1.000	0.734

POSITIVE NUMBER: CONSTRAINT SATISFIED. | THESE VALUES ARE NORMALIZED
 NEGATIVE NUMBER: CONSTRAINT VIOLATED. | BETWEEN +1. AND -1.
 1.000 : CONSTRAINT NOT RELEVANT OR NULLIFIED BY USER.
 -2.000 : CONSTRAINT SUPPRESSED.
 -- : STRAKE NOT EVALUATED.

Analytical Transverse Sagging

INITIAL FRAME ADEQUACY PARAMETER VALUES - MODULE 3 OF SUBSTR. 2

STRAKE	FCPH1	FCPH2	FCPH3	FYCF1	FYCF2	FYCF3	FYTF1	FYTF2	FYTF3	FYCP1	FYCP2	FYCP3	FYTP1	FYTP2	FYTP3
1	0.982	0.865	0.938	1.000	0.842	0.937	0.955	0.982	0.970	0.978	0.980	0.979	0.979	0.935	0.957
2	0.945	0.906	0.979	0.969	1.000	1.000	0.923	0.825	0.923	0.997	0.994	0.996	0.937	0.977	0.957
3	0.953	0.951	0.996	1.000	0.935	1.000	0.917	1.000	0.982	0.991	1.000	1.000	0.994	0.974	0.986
4	0.921	0.892	0.969	0.883	1.000	0.971	1.000	0.811	0.937	1.000	0.955	1.000	0.954	0.980	0.958
5	0.954	0.982	0.968	1.000	1.000	1.000	0.937	0.965	0.953	0.954	0.964	0.959	1.000	1.000	1.000
6	0.953	0.950	0.996	0.933	1.000	1.000	1.000	0.920	0.989	1.000	0.982	0.990	0.983	1.000	0.993
7	0.958	0.962	0.990	0.928	0.986	0.957	0.980	0.931	0.958	0.957	0.953	0.956	1.000	0.989	0.990

MAESTRO Transverse Sagging

INITIAL FRAME ADEQUACY PARAMETER VALUES - MODULE 3 OF SUBSTR. 2

STRAKE	FCPH1	FCPH2	FCPH3	FYCF1	FYCF2	FYCF3	FYTF1	FYTF2	FYTF3	FYCP1	FYCP2	FYCP3	FYTP1	FYTP2	FYTP3
1	0.840	0.796	0.846	0.811	0.784	0.850	1.000	0.914	1.000	0.988	0.967	0.979	0.910	0.878	0.893
2	0.896	0.814	0.954	0.933	1.000	1.000	0.884	0.678	0.853	0.997	0.982	0.990	0.885	0.963	0.924
3	0.937	0.937	0.995	1.000	0.921	1.000	0.882	1.000	0.969	0.985	1.000	1.000	0.991	0.965	0.981
4	0.918	0.783	0.868	0.895	0.722	0.836	1.000	1.000	1.000	1.000	1.000	1.000	0.952	0.905	0.929
5	0.949	0.975	0.966	0.925	0.950	0.943	0.924	1.000	0.943	0.950	0.961	0.962	1.000	0.945	0.949
6	0.936	0.932	0.996	0.906	1.000	1.000	1.000	0.886	0.984	1.000	0.977	0.987	0.974	1.000	0.989
7	0.932	0.948	0.977	0.972	0.914	0.979	0.889	0.953	0.938	0.939	0.980	0.981	1.000	0.937	0.940

POSITIVE NUMBER: CONSTRAINT SATISFIED. | THESE VALUES ARE NORMALIZED
 NEGATIVE NUMBER: CONSTRAINT VIOLATED. | BETWEEN +1. AND -1.
 1.000 : CONSTRAINT NOT RELEVANT OR NULLIFIED BY USER.
 -2.000 : CONSTRAINT SUPPRESSED.
 -- : STRAKE NOT EVALUATED.