



Calhoun: The NPS Institutional Archive

Theses and Dissertations

Thesis Collection

2004-09

Autonomous optimal rendezvous of underwater vehicles

Nicholson, John W.

Monterey California. Naval Postgraduate School

<http://hdl.handle.net/10945/9956>



Calhoun is a project of the Dudley Knox Library at NPS, furthering the precepts and goals of open government and government transparency. All information contained herein has been approved for release by the NPS Public Affairs Officer.

**Dudley Knox Library / Naval Postgraduate School
411 Dyer Road / 1 University Circle
Monterey, California USA 93943**

<http://www.nps.edu/library>



**NAVAL
POSTGRADUATE
SCHOOL**

MONTEREY, CALIFORNIA

DISSERTATION

**AUTONOMOUS OPTIMAL RENDEZVOUS
OF
UNDERWATER VEHICLES**

by

John W. Nicholson

September 2004

Dissertation Supervisor:

Anthony J. Healey

Approved for public release; distribution is unlimited

THIS PAGE INTENTIONALLY LEFT BLANK

REPORT DOCUMENTATION PAGE			<i>Form Approved OMB No. 0704-0188</i>	
Public reporting burden for this collection of information is estimated to average 1 hour per response, including the time for reviewing instruction, searching existing data sources, gathering and maintaining the data needed, and completing and reviewing the collection of information. Send comments regarding this burden estimate or any other aspect of this collection of information, including suggestions for reducing this burden, to Washington headquarters Services, Directorate for Information Operations and Reports, 1215 Jefferson Davis Highway, Suite 1204, Arlington, VA 22202-4302, and to the Office of Management and Budget, Paperwork Reduction Project (0704-0188) Washington DC 20503.				
1. AGENCY USE ONLY (Leave blank)		2. REPORT DATE September 2004	3. REPORT TYPE AND DATES COVERED Doctoral Dissertation	
4. TITLE AND SUBTITLE: Autonomous Optimal Rendezvous of Underwater Vehicles			5. FUNDING NUMBERS	
6. AUTHOR(S) Nicholson, John W.				
7. PERFORMING ORGANIZATION NAME(S) AND ADDRESS(ES) Naval Postgraduate School Monterey, CA 93943-5000			8. PERFORMING ORGANIZATION REPORT NUMBER	
9. SPONSORING / MONITORING AGENCY NAME(S) AND ADDRESS(ES) N/A			10. SPONSORING / MONITORING AGENCY REPORT NUMBER	
11. SUPPLEMENTARY NOTES The views expressed in this thesis are those of the author and do not reflect the official policy or position of the Department of Defense or the U.S. Government.				
12a. DISTRIBUTION / AVAILABILITY STATEMENT Approved for public release; distribution is unlimited			12b. DISTRIBUTION CODE	
13. ABSTRACT (maximum 200 words) The capability of an autonomous underwater vehicle (AUV) to rendezvous with other AUVs was implemented and demonstrated in the Naval Postgraduate School ARIES AUV; providing a method of overcoming the severe range limitations of high-bandwidth underwater data transfer methods in order to enable accelerated access to data collected by a network of data-gathering survey AUVs. Rendezvous was implemented by autonomous reconfiguration of ARIES' operations, using a mission planning module to combine acoustically-transmitted rendezvous requests from survey AUVs with pre-stored survey AUV mission data to generate rendezvous missions based either on time-optimal or energy-optimal trajectories. The planning module efficiently generates rendezvous trajectories based on solutions derived using optimal control theory. A new third layer of control, based on a finite state machine, was added above ARIES' autopilot and mission execution functions in order to initiate mission planning and replanning, activate missions, sequence vehicle operations through seven defined states, control acoustic communications, and handle perturbations and missed rendezvous.				
14. SUBJECT TERMS AUV,UUV, robotics, rendezvous, cooperative behavior, trajectory planning, path planning, acoustic communications, state machine, optimal control			15. NUMBER OF PAGES 146	
			16. PRICE CODE	
17. SECURITY CLASSIFICATION OF REPORT Unclassified	18. SECURITY CLASSIFICATION OF THIS PAGE Unclassified	19. SECURITY CLASSIFICATION OF ABSTRACT Unclassified	20. LIMITATION OF ABSTRACT UL	

THIS PAGE INTENTIONALLY LEFT BLANK

Approved for public release, distribution is unlimited

AUTONOMOUS OPTIMAL RENDEZVOUS OF UNDERWATER VEHICLES

John W. Nicholson
Captain, United States Navy
B.S., United States Naval Academy, 1981
Ocean Engineer, Massachusetts Institute of Technology / Woods Hole Oceanographic
Institution Joint Program in Oceanography and Ocean Engineering, 1988

Submitted in partial fulfillment of the
requirements for the degree of

DOCTOR OF PHILOSOPHY IN MECHANICAL ENGINEERING

from the

**NAVAL POSTGRADUATE SCHOOL
September 2004**

Author:

John W. Nicholson

Approved by:

Anthony Healey
Distinguished Professor of
Mechanical Engineering
Dissertation Supervisor

Joshua Gordis
Professor of
Mechanical Engineering
Dissertation Committee Chair

Young Kwon
Professor of
Mechanical Engineering
Southern Illinois University

Fotis Papoulias
Professor of
Mechanical Engineering

Wei Kang
Professor of Mathematics

Approved by:

Anthony J. Healey, Chair, Department of Mechanical Engineering

Approved by:

Juli Filizetti, Associate Provost for Academic Affairs

THIS PAGE INTENTIONALLY LEFT BLANK

ABSTRACT

The capability of an autonomous underwater vehicle (AUV) to rendezvous with other AUVs was implemented and demonstrated in the Naval Postgraduate School ARIES AUV; providing a method of overcoming the severe range limitations of high-bandwidth underwater data transfer methods in order to enable accelerated access to data collected by a network of data-gathering survey AUVs. Rendezvous was implemented by autonomous reconfiguration of ARIES' operations, using a mission planning module to combine acoustically-transmitted rendezvous requests from survey AUVs with pre-stored survey AUV mission data to generate rendezvous missions based either on time-optimal or energy-optimal trajectories. The planning module efficiently generates rendezvous trajectories based on solutions derived using optimal control theory. A new third layer of control, based on a finite state machine, was added above ARIES' autopilot and mission execution functions in order to initiate mission planning and replanning, activate missions, sequence vehicle operations through seven defined states, control acoustic communications, and handle perturbations and missed rendezvous.

THIS PAGE INTENTIONALLY LEFT BLANK

TABLE OF CONTENTS

I.	INTRODUCTION.....	1
	A. MOTIVATION	1
	B. HISTORY	2
	C. AUV APPLICATIONS.....	5
	D. AUV LIMITATIONS	6
	E. SCOPE OF THIS WORK	7
II.	RENDEZVOUS.....	9
	A. SPACE RENDEZVOUS.....	9
	B. RENDEZVOUS AND INTERCEPT.....	9
	C. COMPARISON OF INTERCEPT GUIDANCE LAWS	10
III.	TIME-OPTIMAL RENDEZVOUS.....	15
	A. OPTIMAL CONTROL FUNDAMENTALS	15
	B. THE AUV EQUATIONS OF MOTION.....	16
	1. Steering Equations.....	17
	2. Simplification of the Steering Equations	17
	3. Surge Equation.....	18
	4. Kinematics	18
	5. Result.....	19
	C. TIME-OPTIMAL SOLUTION FOR CONSTANT SPEED.....	21
	D. TIME-OPTIMAL SOLUTION FOR VARIABLE SPEED.....	24
	E. SOLUTION FOR MOVING TARGET BY NUMERICAL METHOD...26	
	F. EXISTENCE AND UNIQUENESS OF THE SOLUTION.....	29
	G. SUMMARY	31
IV.	ENERGY-OPTIMAL RENDEZVOUS	33
	A. OVERVIEW	33
	B. AUV POWER CHARACTERISTIC	33
	C. USABLE SPEED RANGE	34
	D. MOST EFFICIENT SPEED	35
	E. CHARACTERISTICS OF THE ENERGY-OPTIMAL SOLUTION.....	41
	F. NUMERICAL SOLUTION	42
	G. EXISTENCE AND UNIQUENESS OF THE SOLUTION.....	44
	H. SUMMARY	44
V.	IMPLEMENTATION OF AUV RENDEZVOUS	45
	A. OVERVIEW	45
	B. IMPLEMENTATION OF OPTIMAL CONTROLS	45
	C. CONCEPT OF OPERATIONS.....	46
	1. Network Comprised of One Server and Multiple Sensor Vehicles	46
	2. Server Vehicle Knowledge of Sensor Vehicle Mission.....	47
	3. Default Server Vehicle State = Loiter	47

4.	Minimal, Dual-Mode Communications	47
5.	Rendezvous in Response to Sensor Vehicle Request	47
6.	Vehicle Network Operates Asynchronously	48
7.	Sensor Vehicle Does Not Maneuver for Rendezvous.....	48
8.	Vehicles Maintain Ground Track and Speed Through Water.....	49
9.	Optimality	49
10.	Robustness	49
D.	ROBUSTNESS FEATURES.....	49
1.	Rendezvous Queue Management.....	49
2.	Missed Rendezvous Logic.....	50
3.	Rendezvous Request Check Sum.....	50
4.	Mission Feasibility Check	50
5.	Currents	50
6.	Navigation Accuracy.....	51
E.	BASELINE ARIES CHARACTERISTICS	51
1.	Hardware	51
2.	Software	53
F.	HARDWARE MODIFICATIONS TO ENABLE RENDEZVOUS.....	56
G.	SUMMARY OF NECESSARY SOFTWARE MODIFICATIONS	56
1.	Dynamic, Autonomous Mission Planning Process.....	56
2.	Additional Layer of Control	57
3.	Mission Activation	57
4.	Queue Management.....	58
5.	Shared Memory.....	58
6.	Modem Upgrade.....	58
H.	MISSION PLANNING PROCESS	60
1.	Efficient Use of Computer Resources	60
2.	Data Required for Mission Planning.....	61
3.	Elements of a Rendezvous Request	62
a.	<i>Sender Identity</i>	<i>62</i>
b.	<i>Present Track Segment.....</i>	<i>62</i>
c.	<i>Progress Along Present Track Segment.....</i>	<i>62</i>
d.	<i>Time Stamp.....</i>	<i>62</i>
e.	<i>Check Sum.....</i>	<i>63</i>
4.	Pre-Processing Target Data	63
a.	<i>Compute Segment Lengths</i>	<i>63</i>
b.	<i>Compute Segment Courses Over Ground.....</i>	<i>64</i>
c.	<i>Compute Target Vehicle Speed Over Ground and Heading for Each Segment</i>	<i>64</i>
5.	Planning Time-Optimal Rendezvous	64
a.	<i>Validating Rendezvous Request Format.....</i>	<i>64</i>
b.	<i>Determining Future Target Vehicle Positions and Synchronizing Data.....</i>	<i>65</i>
c.	<i>Locating the Time-Optimal Rendezvous Point.....</i>	<i>66</i>
d.	<i>Locating Remaining ARIES Way Points</i>	<i>75</i>
e.	<i>Planning Speeds.....</i>	<i>76</i>

	<i>f.</i>	<i>Setting Way Point Timeouts</i>	<i>76</i>
	<i>g.</i>	<i>Planning GPS Fixes.....</i>	<i>77</i>
	<i>h.</i>	<i>Setting Watch Radii</i>	<i>77</i>
	<i>i.</i>	<i>Setting Depths and Altitudes</i>	<i>77</i>
	<i>j.</i>	<i>Writing the Mission to File.....</i>	<i>78</i>
6.		Planning Energy-Optimal Rendezvous.....	78
	<i>a.</i>	<i>Bounding the Energy-Optimal Rendezvous Point.....</i>	<i>78</i>
	<i>b.</i>	<i>Locating the Energy-Optimal Rendezvous Point.....</i>	<i>81</i>
I.		STATE MACHINE.....	82
	1.	Loiter	84
		<i>a. Actions</i>	<i>84</i>
		<i>b. Transitions.....</i>	<i>85</i>
	2.	Plan Mission	85
		<i>a. Actions</i>	<i>85</i>
		<i>b. Transitions.....</i>	<i>85</i>
	3.	Closing.....	86
		<i>a. Actions</i>	<i>86</i>
		<i>b. Transitions.....</i>	<i>87</i>
	4.	Initiate Rendezvous.....	87
		<i>a. Actions</i>	<i>87</i>
		<i>b. Transitions.....</i>	<i>88</i>
	5.	Rendezvous	88
		<i>a. Actions</i>	<i>88</i>
		<i>b. Transitions.....</i>	<i>88</i>
	6.	Query Position.....	88
		<i>a. Actions</i>	<i>88</i>
		<i>b. Transitions.....</i>	<i>88</i>
	7.	Terminate.....	88
		<i>a. Actions</i>	<i>89</i>
		<i>b. Transitions.....</i>	<i>89</i>
	8.	Receipt of Rendezvous Requests and Other Modem Messages.....	89
	9.	Initiating Modem Transmissions.....	90
J.		MISSION ACTIVATION	90
K.		RENDEZVOUS QUEUE AND QUEUE MANAGEMENT	91
L.		MODEM	92
M.		SHARED MEMORY	93
N.		SYSTEM IN-LAB TESTING	95
VI.		DEMONSTRATION OF CONCEPT	99
	A.	METHODS	99
	B.	STATE MACHINE AND RENDEZVOUS QUEUE, LABORATORY RUN.....	100
	C.	TIME-OPTIMAL RENDEZVOUS, LABORATORY RUN	104
	D.	ENERGY-OPTIMAL RENDEZVOUS, LABORATORY RUN	109
	E.	TIME-OPTIMAL RENDEZVOUS, IN-WATER RUN	111
	F.	ENERGY-OPTIMAL RENDEZVOUS, IN-WATER RUN.....	114
VII.		CONCLUSION	117

A. SUMMARY	117
B. RECOMMENDATIONS.....	119
LIST OF REFERENCES.....	123
INITIAL DISTRIBUTION LIST	127

LIST OF FIGURES

Figure 1.	Intercept (a) and Rendezvous (b).....	10
Figure 2.	Pursuit (a) and Proportional Navigation (b).....	11
Figure 3.	Pursuit and Proportional Navigation of a 5.5 Meter Per Second Chaser Vehicle Intercepting a 6 Meter Per Second Target Vehicle	12
Figure 4.	Comparing Proportional Navigation and Pursuit Guidance, Maneuvering Constant Speed Target (After: Hutchins and Roque, 1995)	13
Figure 5.	AUV State Variables.....	19
Figure 6.	Initial and Final Vehicle Positions.....	21
Figure 7.	Time Optimal Trajectory, Constant Speed	23
Figure 8.	Dubins Solution	24
Figure 9.	Initial and Final States, Variable Speed.....	25
Figure 10.	Vehicle Tracks, MATLAB FMINCON Time-Optimal Rendezvous Solution.....	27
Figure 11.	Control Histories, MATLAB FMINCON Time-Optimal Rendezvous Solution.....	28
Figure 12.	Speed and Heading, MATLAB FMINCON Time-Optimal Rendezvous Solution.....	28
Figure 13.	Reachable Positions for Chaser and Target Vehicles	30
Figure 14.	ARIES Power Characteristic.....	34
Figure 15.	Target Positions and Ranges as a Function of Time, With Decomposition of Target Velocity u_t Into Components Across (u_{t_x}) and Into (u_{t_y}) the Line of Sight	36
Figure 16.	ARIES Rendezvous With Maneuvering Target, Waypoints Annotated.....	39
Figure 17.	Energy to Rendezvous, as a Function of Time, With Way Points Annotated.....	39
Figure 18.	Vehicle Tracks, MATLAB FMINCON Solution to Energy-Optimal Rendezvous.....	43
Figure 19.	Control Histories, MATLAB Solution to Energy-Optimal Rendezvous.....	43
Figure 20.	Speed and Heading, MATLAB Solution to Energy-Optimal Rendezvous	44
Figure 21.	ARIES Vehicle Diagram (After: Marco, 2001).....	52
Figure 22.	ARIES Baseline Computer Software Architecture, Showing Processors, Network Connections, Processes, Shared Memory (SM) Structures, and Mission Definition Files. Boxed Region in QNXE Was Later Modified for Rendezvous as shown in Fig. 24 (After: Marco, 2001)	54
Figure 23.	Structure of ARIES Way Point File (After: Marco, 2001)	55
Figure 24.	QNXE Software Modifications to Implement Rendezvous. Baseline ARIES Features are Light. Proxy Trigger and Dark Features were Added for Rendezvous	59
Figure 25.	Comparison of ARIES Speed Transient and First-Order Model	68
Figure 26.	Advance and Transfer	68
Figure 27.	ARIES Advance, Transfer, and Path Length Versus Course Change	69

Figure 28.	Calculating Effects of Course/Speed Changes With Currents. Large Course Change (a). Small Course Change With Speed Change Continuing After Course Change (b).....	70
Figure 29.	ARIES Rendezvous Trajectory.....	71
Figure 30.	ARIES on Target Track Causes Planning Non-Convergence. Initial Computation of Transfer (a). First Refinement Iteration (b). Result of First Iteration(c).....	73
Figure 31.	Watch Radius.....	78
Figure 32.	Earliest Possible Energy-Optimal Rendezvous (a). Latest Possible Energy Optimal Rendezvous (b).....	80
Figure 33.	ARIES Finite State Machine, Showing States and Transitions.....	83
Figure 34.	ARIES Three-Layer Rendezvous Software Architecture.....	84
Figure 35.	Shared Memory Segments and Variables.....	94
Figure 36.	ARIES Demonstration Setup.....	100
Figure 37.	Mission Planning, Time-Optimal Rendezvous, Laboratory Run.....	105
Figure 38.	Mission Replanning, Time-Optimal Rendezvous, Laboratory Run.....	108
Figure 39.	Energy to Rendezvous versus Rendezvous Position, Energy-Optimal Laboratory Run.....	110
Figure 40.	Mission Planning, Energy-Optimal Rendezvous, Laboratory Run.....	111
Figure 41.	Time-Optimal Rendezvous, In-Water Run.....	112
Figure 42.	ARIES Speed Command and Speed, Rudder Angle, and Heading, Time-Optimal Rendezvous, In-Water Run.....	113
Figure 43.	Closure for Energy Optimal Rendezvous, In-Water Run.....	114

LIST OF TABLES

Table 1.	Modem Messages Initiated by the State Machine	91
Table 2.	Incoming Messages Recognized by Modem Process	93
Table 3.	ARIES Laboratory Mission 1, Events 1-5.	101
Table 4.	ARIES Laboratory Mission 1, Events 6-11.	102
Table 5.	ARIES Laboratory Mission 1, Events 12-19.	103
Table 6.	ARIES Laboratory Mission 1, Events 20-24.	104
Table 7.	Parsing of Laboratory Time-Optimal Rendezvous Request	106
Table 8.	ARIES Initial Rendezvous Mission, Laboratory Time Optimal Run.	107
Table 9.	Events and Responses Following Mission Replanning, Time-Optimal Laboratory Run.	109

THIS PAGE INTENTIONALLY LEFT BLANK

ACKNOWLEDGMENTS

To my lovely, devoted wife Christine - for her patience and for taking care of the family while I worked away on this tiny piece of the universe.

To the United States Navy – for three trips to college, 27 rewarding years of active duty (to date), and the opportunity to serve as a permanent military professor.

To Dean Michael Halbig and Professor Terry Dwan at the United States Naval Academy, and former squadron commanders Captain Butch Hansen and Captain Al Hochevar - for supporting my entry into the Permanent Military Professor Program.

To Distinguished Professor Anthony J. Healey - for creating and sustaining the Naval Postgraduate School (NPS) Center for Autonomous Underwater Vehicle (AUV) Research, and for providing the inspiration and resources for this work.

To fellow members of the NPS Center for AUV Research – for their assistance.

To Professor Terry McNelley at NPS - for invaluable support and guidance during my arrival and initial studies there.

To fellow PMPs with whom I studied – for their support, camaraderie, and commiseration.

THIS PAGE INTENTIONALLY LEFT BLANK

I. INTRODUCTION

A. MOTIVATION

This work furthers the capabilities of an evolving class of robot, the autonomous underwater vehicle (AUV). AUV's represent the latest development in a centuries-old progression of human efforts to work in the marine environment, efforts motivated by economic, scientific, military, and other reasons.

Work in the marine environment is difficult on many levels. Human operators are out of their natural element and require protection and life support. Communications bandwidth and range are more limited than for most other environments. This complicates the control of underwater systems, and can result in loss of the system due to an inability to communicate with or locate it. Significant forces such as winds, waves, currents, and hydrodynamic and hydrostatic forces affect and disrupt operations. The environment is corrosive, fouling, and incompatible with electrical/electronic equipment. As a result, operations tend to be difficult, time consuming, expensive, and hazardous to both machine and operator.

AUVs are a recent solution for achieving desired objectives in the marine environment while addressing and overcoming the inherent challenges. As technology in any field of work advances, it is leveraged to maximize benefit and minimize cost. The same is true in this context. Beginning with boats and nets, human ingenuity has extended man's presence and capabilities in the marine environment to maximize benefits while reducing the costs and risks of doing so. Advances in technology brought successive improvements in marine propulsion; progressing from oars, to sails, to steam, to nuclear and other current methods of propelling vehicles delivering cargo, warheads, sensors, or other payloads. Sensors evolved from the lead line, used for taking soundings, to sonar for taking soundings and locating objects other than the sea floor, to high resolution sonar for identifying the details of the sea floor and underwater objects. Cameras, line scanners, magnetometers, sub-bottom profilers, and numerous types of

oceanographic sensors have been developed to further man's reach into and understanding of the marine environment.

A key element of man's operations in the marine environment has been the human element itself, which has been a bit of the proverbial "double edged sword". On the negative side are such liabilities as the costs of salaries, benefits, and training; the costs and logistics of protection from the elements and of life support; time lost to rest and recreation; and the consequences of injury or loss of life. As is the case in such endeavors as space exploration, protecting and supporting human life entails significant increases in the size, complexity, and expense of equipment; reduction of mission duration; and added risk. The positive side of the human element is its unmatched versatility for performing a variety of tasks, for which there has long been no substitute in the complex marine environment. Additionally, unexpected situations frequently occur requiring human intervention, as human intelligence and reasoning are unequalled for making the appropriate decision in dealing with the new situation. Although removing humans from such operations is highly desirable from a liability standpoint, doing so has been challenging. Automation has advanced the process of removing the human element over time, starting with the simplest tasks. Many more complex tasks are yet to be successfully automated. The human element enhances operations in the marine environment, albeit at a price. A desirable goal would be to remove the human element while preserving the effectiveness inherent in it.

AUVs remove the human element almost completely; more so than in related unmanned aerial, land, space, and sea surface vehicles. Communications methods available to these other vehicles provide ample opportunity for human participation and intervention during the course of a mission. AUVs are significantly constrained in their ability to communicate with external operators, and are therefore highly dependent on autonomous operation. The nature of their operating environment motivates much progress in the field of autonomy.

B. HISTORY

Development of AUVs has progressed in stages over the last few centuries. As is frequently the case, military operations provided significant motivation to develop and

advance technology. As in the above discussion, military effectiveness also benefits from inclusion of the human element. And, as above, the desire to minimize the cost and risk of human involvement motivates developments in automation. One typical military objective throughout history has been to deliver an effective explosive charge to the desired target with the objective of destroying it. Over time, automation has gradually replaced human methods of delivering the charge to the desired target. In 1585, during the siege of Antwerp by the Spanish Armada, defenders of the city sent an unmanned vessel filled with explosives and fused with a timer down the river Scheldt. It succeeded in its mission, which was to blast an opening into a barricade built across the river. The automation required was minimal, as the river's banks constrained the vessel's path to arrive at the barricade, its flow brought it to the barricade, and the timer needed only delay the explosion until after the vessel was swept against the barricade (Gray, 1991).

The more challenging and useful situation involved delivering the explosive payload below the waterline of a moving target in open water. The spar torpedo, placed on the end of a long pole at the bow of a small manned vehicle, represented an early solution. This involved a human element, which guided the vessel and its attached explosive payload to the intended target. The human cost and risk was to be mitigated by the distance provided by the length of the spar, or by the length of a rope that was pulled taut to detonate the torpedo after it was implanted in the target and the delivery vehicle backed away. As was demonstrated by the CSS Hunley's sinking of the USS Housatonic during the Civil War, the weapon with its human controls was very effective; but the loss of the Hunley also demonstrated that the cost was too high and that further automation of the concept was necessary (Bak, 1999). The desire to achieve the same level of effectiveness, but at lower cost, resulted in development of possibly the first AUV, the Whitehead torpedo. It was developed by Robert Whitehead during the latter part of the 19th century and further removed the human element. In fact, once launched, there was no human element. Whitehead overcame significant technical challenges in designing a suitable propulsion and control system for his torpedo. Propulsion was provided by a variety of different engines, and control was provided by a combination of gyroscope-based heading control and depth-cell based depth control (Gray, 1991).

Current torpedoes and AUVs are improvements on Whitehead's invention. His propulsion designs were succeeded by internal combustion engines or electric drive powered by various types of batteries. His straight-running torpedo carried no sensors, other than an exploder to detonate the warhead when it sensed contact with a solid object. However follow-on torpedoes carried equipment such as wake or acoustic sensors to detect, track, and home on targets; as well as magnetic and other sensors to sense the proximity of a target and detonate the warhead at the appropriate time. Additionally, enabling a torpedo to process its sensor data to home in on a target required the addition of computational capability, first analog, then digital (Naval Undersea Warfare Center, 1998). Military necessity brought a high level of autonomy and technical sophistication to underwater vehicles.

Torpedoes represent one path of development towards AUVs, another was progress in sensor technology. Beginning with lead line soundings taken by dropping a tethered weight to the bottom to determine water depth, a variety of tethered measurement devices and sensors have been used in the ocean environment. These include oceanographic instruments and camera sleds. The device was lowered to the desired depth at the desired location to take the measurement or image, then brought back to the deploying vessel where the data was downloaded from the device (McConnell, 1982). This method of gathering data did not allow access to the data until the device was removed from the area to be sensed and back on deck. This not only delayed presentation of the data to the human operator, it prevented adaptive planning of the data gathering operation based on conditions sensed by the device (Andrews, 2004). Improvement came with tethers which also contained communication channels, such as wiring or optical fiber. Access to sensed data was available instantaneously, and the device could be repositioned in response to the sensed data to adaptively plan the data gathering operation and improve the usefulness of gathered data. The feedback provided by the communications link made control of the tethered device possible, and gave rise in the 1950's to remotely operated vehicles (ROV) (Marine Technology Society, 2003). An ROV is typically outfitted with thrusters, control surfaces, and other equipment such that a human operator can drive the ROV by remote control in the performance of its mission.

This link to a human element allows ROVs to perform complex undersea missions without the actual presence of the human, eliminating the need for human requirements such as life support and protection at depth. Instead, the human element is located at a safe distance, either on a support vessel or at a networked location thousands of miles away. Additionally, the electrical connection to the surface vessel provides essentially unlimited power to the device

Versatile as ROVs are, there are still limitations to be overcome. The requirement for a tether and support vessel limits the operations of the ROV to the length of the tether, and the speed at which the tether can be towed. Additionally, the necessity of the surface vessel limits ROV operations to areas accessible to the surface vessel, something which may be constrained by sea conditions, hydrography, ice, hostile action, or the desire to remain covert. Also, there is the expense of a continuously present support vessel.

AUVs represent a follow-on development in both sequences of technological progress. They build on the fusion of propulsion, control, and guidance/logic technology developed to improve torpedo capabilities, and they are used as platforms to carry the sensors that have been tethered to other vessels. In doing so, those sensors may be employed more effectively than by tethered or other means.

C. AUV APPLICATIONS

Many applications for AUVs have been realized or are under development. Naval missions include deep-ocean search (Urich, 1995), mine countermeasures (Wernli, 1997), oceanographic measurement (Peterson and Head, 2002), intelligence, surveillance, reconnaissance, anti-submarine warfare and various support missions (Department of the Navy, 2000).

An example of an economic application is the Hugin AUV, which has been used extensively and effectively for offshore petroleum exploration. It carries a variety of sensors to the vicinity of the ocean floor, a task previously performed by a sensor towed by a surface vehicle. By overcoming the speed and maneuvering limitations associated with the towed deployment scheme, survey time is reduced by over 50% (Chance, 2001).

AUVs are used extensively to gather oceanographic data, bringing methods of measurement previously not possible. They have been deployed under ice (Jones, 2002), where surface vessels could not operate, gathering data faster than would have been possible by boring through the ice from above and lowering instruments to take measurements. Long-duration AUVs such as gliders have remained at sea and gathered oceanographic data for extended periods of time without the need for a support vessel, and have demonstrated the ability to operate from an undersea dock, periodically leaving to gather data and returning to download data and recharge batteries (Curtin and Bellingham, 2001).

D. AUV LIMITATIONS

AUVs, however, are by no means a panacea. For all their advantages, there are areas in which they are inferior to tethered vehicles. One consequence removing the tether is that power is limited to what can be carried onboard. This limitation was the motivation for the development of nuclear power on manned submarines, and this same limitation on smaller, unmanned AUVs that has spurred development of advanced battery and fuel cell technology. Untethered vehicles also allow little or no human involvement in their mission, due to the limited communications bandwidth available. As a result, the complexity of their missions is limited by the degree to which they can be automated. Overcoming this limitation motivates further research in autonomy and underwater communications. A related consequence of this limited communications bandwidth is limited access by the operator to data gathered by the AUV. The most common method of retrieving the data gathered by the AUV is to recover the vehicle at the end of its mission and download the data via a computer network connection. In time-critical operations the resulting time delay may be unacceptable. Other methods, such as low-bandwidth acoustic communications or periodic radio communications periods on the surface, are also available but may not be operationally desirable. If covertness is a requirement for the operation, one reason for using an AUV instead of a vehicle tethered to a surface vessel, such methods of transmitting data may compromise covertness. Methods of transferring data covertly and at high bandwidth exist, such as optical (Lacovara, 2003) or high frequency acoustic modem exist (Kojima, 2002), but are of limited range (Etter, 1996).

E. SCOPE OF THIS WORK

This work develops a high data rate method of covertly gaining access to data gathered by AUVs. Such autonomous, networked, accelerated access to data is in accordance with current Chief of Naval Operations guidance (Clark, 2002). This work implements the server vehicle concept proposed by (Marco and Healey, 2000) as a means of retrieving data from data-gathering vehicles to make it available to the operator while the survey is in progress. This method uses no radio transmissions, and limits other transmissions to either short-duration long-range acoustic or short-range acoustic or optical transmissions. Covertness is enhanced by this minimization of detectable transmissions.

The approach for accomplishing this objective is autonomous AUV rendezvous, in which an AUV designated as a server vehicle is tasked to download data from a vehicle equipped with sensors which is gathering data on a survey, surveillance, or similar mission. After obtaining the data, the server vehicle delivers it to a node where it can be transmitted to the operator. The operation comprises a network of cooperating vehicles, with a single server vehicle servicing one or more sensor vehicles.

Such a cooperative vehicle network of cannot adhere rigidly to a pre-scripted sequence of operations, as the unpredictable nature of sensed data, navigational errors, disturbances, and operational details make a priori knowledge of all necessary mission planning parameters impossible. As a result, rendezvous planning must be adaptive enough to bring the server vehicle to within short-range communications range of the sensor vehicle regardless of these unpredictable mission parameters. Additionally, because the adaptive planning must occur during the operation and after final interaction with the human element, the planning process must be autonomous. This builds on work by (Marr, 2003), wherein individual parameters in the AUV's mission were transmitted by acoustic command and changed inside the vehicle. In this work, a set of parameters describing the location of the sensor vehicle are transmitted to the server vehicle, which uses the parameters to generate a new mission for itself and then executes the mission.

Finally, the rendezvous process should be optimized in order to satisfy the objectives of the operation. Because the objective of the rendezvous concept is to

accelerate access to AUV data, it may be desirable to plan each rendezvous such that it is completed in as short a time as possible. Solutions to this time-optimal problem will be shown to require closing the rendezvous point at high speed, a mode of operation which quickly depletes the limited energy capacity of an AUV and therefore shortens its time on station. Recognizing the energy limitations of AUVs, it may be desirable instead to perform each rendezvous using the minimum possible energy. These energy-optimal solutions provide reasonable access times to AUV data and maximize server vehicle time on station. Other optimization objectives may also be desirable. This work addresses the above two optimization objectives, finding analytical/numerical solutions to both and implementing practical and efficient optimization of the rendezvous solution.

This work made use of the Naval Postgraduate School Acoustic Radio Interactive Exploratory Server (ARIES) AUV. The unique behaviors necessary for AUV rendezvous; including dynamic mission planning, mission reconfiguration, command and control communications, and a new higher layer of operational control; were implemented in this AUV.

II. RENDEZVOUS

A. SPACE RENDEZVOUS

Decades before the space age the orbital rendezvous problem was being considered, with a focus on effecting rendezvous to meet specified optimization objectives. Hohmann (1925) first solved the problem of transferring a space vehicle from one orbit to another while expending a minimum of energy. The realization of space operations in the mid twentieth century motivated extensive work in optimal space rendezvous (Marec, 1979). In fact, the vast majority of the literature on the topic of optimal rendezvous pertains to space vehicles.

Optimization objectives of space maneuvers include the minimum energy and minimum time, as will be considered here, however the physics of the space environment are radically different. The space environment is characterized by gravity, centripetal, and limited-duration thrust forces; whereas the AUV operating environment is dominated by drag, control surface, and near-continuous thrust forces. As a result, optimal rendezvous solutions for spacecraft have little utility for AUVs.

B. RENDEZVOUS AND INTERCEPT

Of greater relevance is the extensive work done with endo-atmospheric missiles and underwater vehicles. This is true because these tend to be finned vehicles operating under the influences of thrust and drag, as are AUVs. However, most of the literature for these vehicles involves intercept vice rendezvous. Figure 1 illustrates the difference. Designating the vehicle which maneuvers as the “chaser vehicle” and the second vehicle as the “target vehicle”, the objective of intercept is for the chaser vehicle to match the position of the target vehicle at some future point in time along the target vehicle’s track. Intercept is a momentary condition satisfactory for most weapons systems requirements that are the motivation of much of the research on the topic. In such cases a warhead is detonated near the point of intercept and no further maneuvering is necessary. In fact, warhead detonation generally makes further chaser vehicle maneuvers impossible as the chaser vehicle is destroyed. Rendezvous extends the concept of intercept, also matching vehicle positions but adding the requirement of matching velocity as well. As a result,

there is little if any relative velocity between vehicles and the vehicles remain in close proximity for an extended period of time.

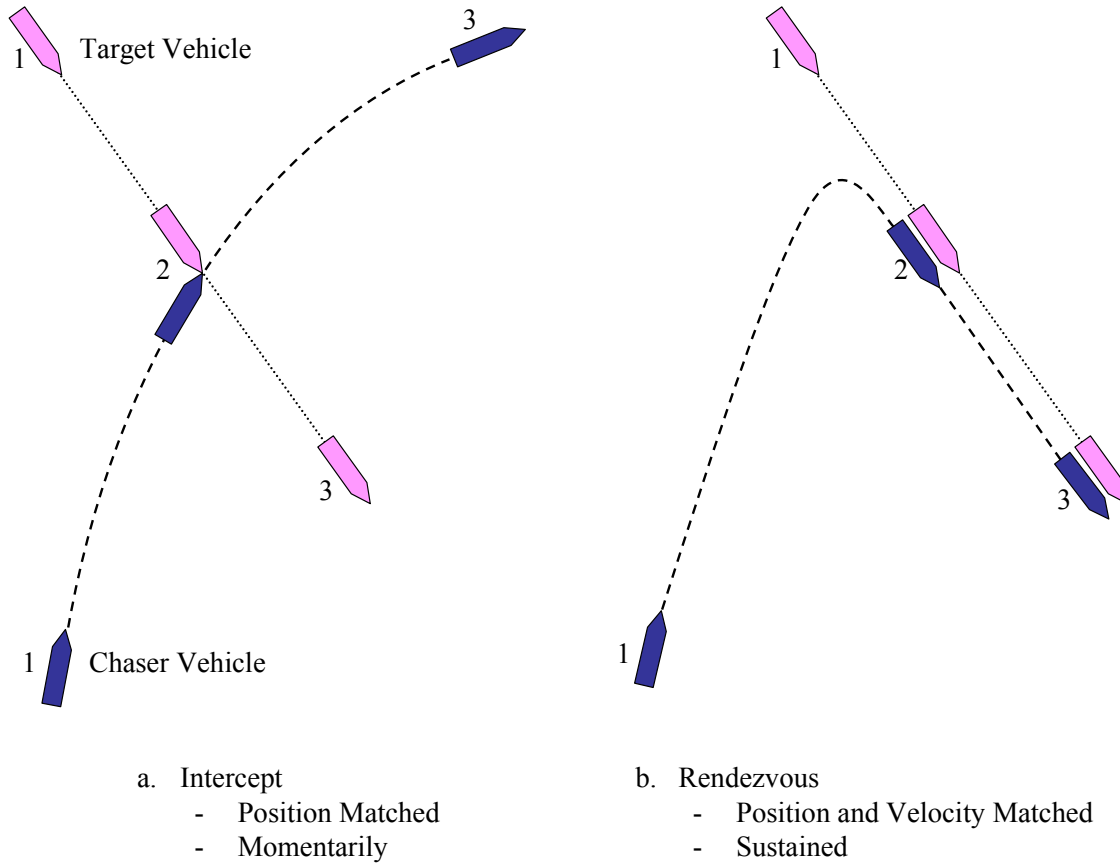

Figure 1. Intercept (a) and Rendezvous (b)

C. COMPARISON OF INTERCEPT GUIDANCE LAWS

Intercept is a useful step towards rendezvous since an intercept trajectory differs from a rendezvous trajectory primarily in the relatively short time period just prior to the rendezvous. For the remainder of the trajectory, which comprises the majority of the trajectory, intercept principles are of great utility. Many guidance laws have been developed for one vehicle to efficiently intercept a target vehicle, and two that represent the two fundamental approaches are known as pursuit and proportional navigation. These are shown in Fig. 2.

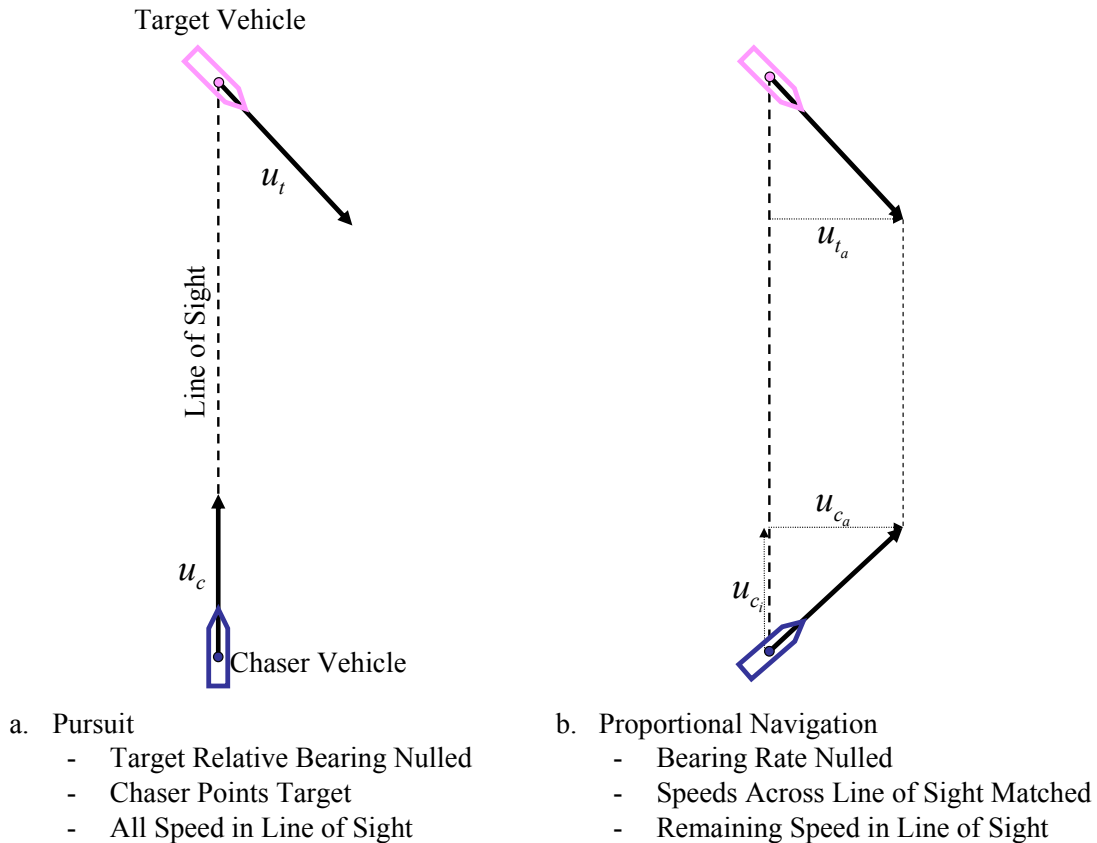

Figure 2. Pursuit (a) and Proportional Navigation (b)

The pursuit guidance law acts to null the target vehicle’s bearing relative to the centerline of the chaser vehicle. By doing so the chaser vehicle always points the target, and all its forward speed u_c is applied in the line of sight to maximize range rate at any given time. For a stationary target in Euclidean space this law provides the time-optimal intercept trajectory as the chaser vehicle is driven along the shortest possible path to the target. It is a simple law to implement since the chaser vehicle need only maneuver to keep the target’s image in the center of its homing sensor.

Proportional navigation is probably the most studied and utilized of the missile guidance laws (Zarchan 2002). It intercepts the target by nulling the target’s bearing rate, generating the “constant bearing, decreasing range” condition that leads to collision between moving vehicles. Proportional navigation apportions the chaser vehicle’s

forward speed u_c along two orthogonal axes. Chaser vehicle course is adjusted such that its speed across the line of sight, u_{c_s} , matches target speed across the line of sight u_{t_s} . Doing so puts the target vehicle in a position of having no lateral velocity relative to the target vehicle. The remainder of u_c , the speed in the line of sight u_{c_l} , is then applied in the direction of the target in order to close to intercept. For the case of a stationary target this yields the same solution as pursuit guidance.

Since its speed is always directed at the target, pursuit might seem to be the time-optimal guidance law. However, Fig. 3 illustrates why this is usually not the case.

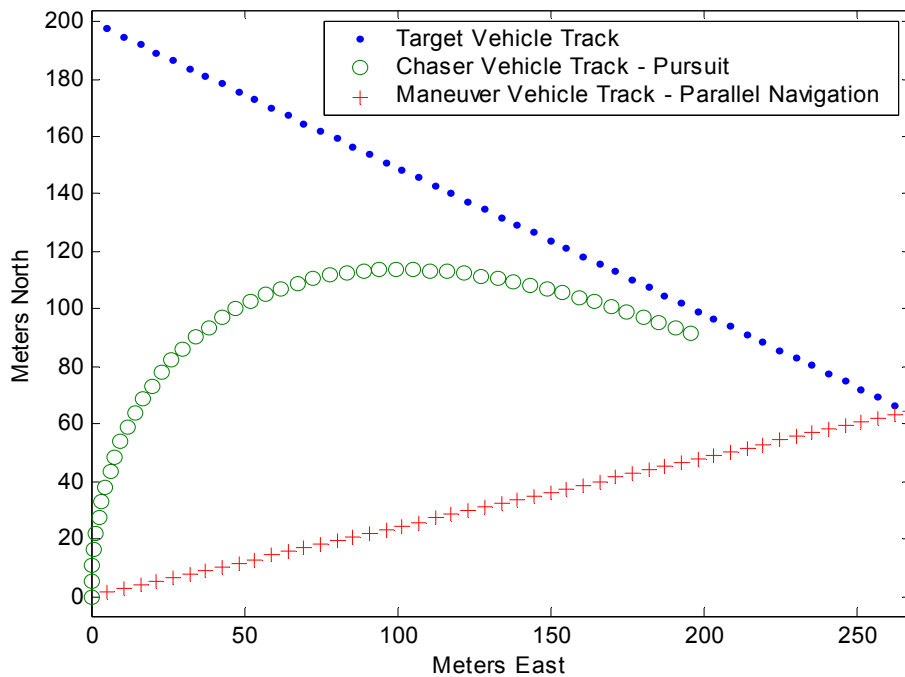

Figure 3. Pursuit and Proportional Navigation of a 5.5 Meter Per Second Chaser Vehicle Intercepting a 6 Meter Per Second Target Vehicle

A constant-velocity target vehicle moving at 6 meters per second on a constant southeasterly course and speed is to be intercepted by a chaser vehicle moving at 5.5 meters per second. The chaser vehicle departs the origin, once using pursuit guidance and once using proportional navigation, and the positions of both vehicles are shown at 1

second intervals for a total of 50 seconds. The pursuit guidance law initially closes range more rapidly, but does not follow a direct path to the intercept point. Instead, because of the mismatch in speeds across the line of sight, the target vehicle changes bearing and presents a more opening aspect throughout the problem. The chaser vehicle falls into a “tail chase” with the target vehicle and closure rate drops significantly. In fact, because the chaser vehicle is slower than the target vehicle, range between vehicles eventually begins to open and the opportunity to intercept is lost. Compare this to proportional navigation, which in this case allows the chaser to intercept the target vehicle even though it is at a speed disadvantage. Note also that proportional navigation follows a straight-line path to the intercept point, wasting no path length enroute. In fact, proportional navigation has been shown to be the time optimal method for intercepting constant-velocity targets (Mehrandezh, Sela, Fenton, and Benhabib, 1999).

Figure 4 illustrates the relative merits of these two guidance laws for the next level of complexity, the realistic case of a constant-speed maneuvering target.

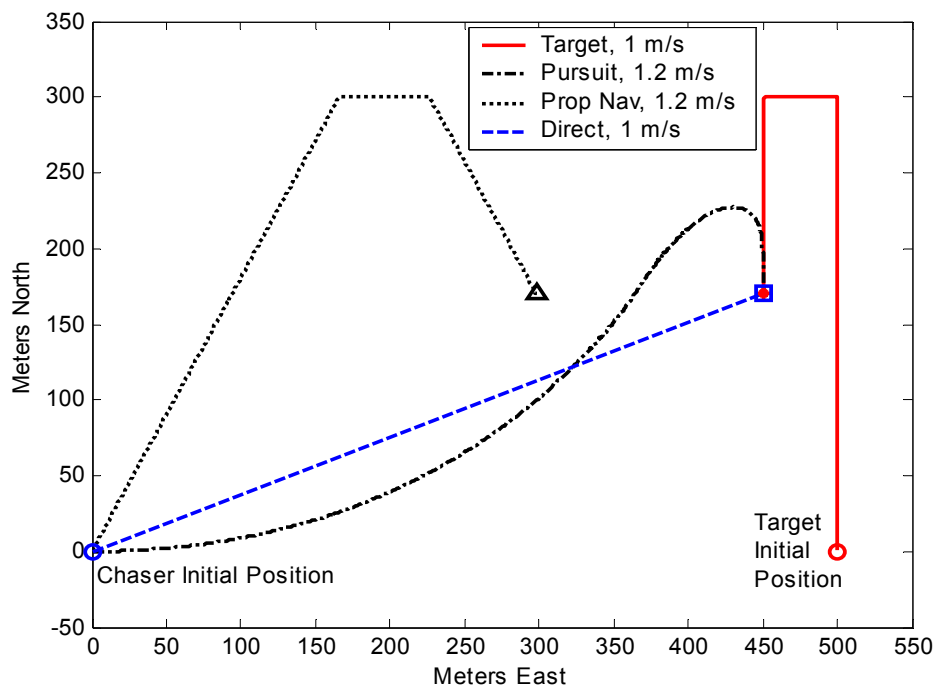

Figure 4. Comparing Proportional Navigation and Pursuit Guidance, Maneuvering Constant Speed Target (After: Hutchins and Roque, 1995)

Here a 1 meter per second target vehicle follows a typical AUV survey pattern composed of parallel tracks. A chaser vehicle departs the origin as before, using each of the guidance laws. The chaser vehicle's speed is 1.2 meters per second, and vehicle positions for 480 seconds are shown. In this case proportional navigation clearly results in excessive path length as the chaser vehicle tracks the target vehicle's maneuvers. Unlike the previous example, pursuit guidance is now superior to proportional navigation in that interception occurs sooner. However, pursuit guidance is not optimal, as a direct path to the same rendezvous point and rendezvous time would have required the chaser vehicle to travel at only 1.0 meters per second thereby saving 42% of the propulsion energy required to reach the intercept point. Conversely, had the chaser vehicle traveled a direct route at 1.2 meters per second to intercept the target vehicle, it would have intercepted it in 421 seconds, a 12% time savings. Planning this direct path, however, requires a priori knowledge of target maneuvers.

Rendezvous can be seen as an extension of the above discussion, provided that trajectory planning take into account the final course and speed changes required to match target vehicle velocity as well as position.

Trajectory planning benefits from a priori knowledge of target vehicle movements. This is not a valid assumption for much of the previous intercept work, since this work stems from weapons research and therefore the target can be expected to attempt to evade the incoming interceptor. However, in the context of AUV rendezvous, a cooperative behavior between vehicles, it would be a reasonable assumption that the chaser vehicle could be provided the details of the chaser vehicle's mission prior to the start of the operation. This assumption will be used in the rest of this work to optimize the rendezvous process.

III. TIME-OPTIMAL RENDEZVOUS

A. OPTIMAL CONTROL FUNDAMENTALS

Optimal control problems involve finding the sequence of control inputs to drive a system from a prescribed initial state to a prescribed final state while minimizing a specified performance index $J(\mathbf{x})$. Denoting the set of control inputs as the vector \mathbf{u} , and the states by the vector \mathbf{x} , the general form of the performance index is

$$J(\mathbf{x}, \mathbf{u}, t_f) = \phi(t_f) + \int_0^{t_f} L(\mathbf{x}, \mathbf{u}, t) dt \quad (3.1)$$

The term $\phi(t_f)$ is some specified function of the final state, and the integral term is a function of states and controls throughout the time period in question.

The four necessary conditions for optimality, derived using the calculus of variations, are satisfaction of boundary conditions; plus

$$\frac{\partial H}{\partial \mathbf{p}} = \dot{\mathbf{x}} \quad (3.2)$$

$$\frac{\partial H}{\partial \mathbf{x}} = -\dot{\mathbf{p}} \quad (3.3)$$

$$\frac{\partial H}{\partial \mathbf{u}} = \mathbf{0} \quad (3.4)$$

Where the Hamiltonian H , defined as

$$H = L + \mathbf{p} \bullet \dot{\mathbf{x}} \quad (3.5)$$

is a convenient grouping of terms resulting from the derivation of the above conditions. It consists of the integrand of the performance index, plus the inner product of the costate vector \mathbf{p} and the time derivative of the state vector (Bryson, 1999).

The above assume that the magnitude of control inputs is unconstrained. However, in practical systems the magnitudes of control inputs are necessarily constrained, which can complicate solution of optimal control problems. Frequently the

optimal control solution obtained using the above equations requires infinite control effort. For example, the time-optimal problem of finding the force to be applied to a mass to accelerate it to a specified speed in the minimum possible time has as its solution an infinite force over an infinitesimal time period, the integral of which equals the impulse required to change the momentum of the mass the specified amount. Realistic systems with constraints on controls were addressed by (Pontryagin, 1962), who introduced the minimum principle as a generalization of Eq. 3.3 to specify that the optimal control minimizes the Hamiltonian at each instant of time, or

$$u = \operatorname{arg\,min}(H) \quad (3.6)$$

The rendezvous problem clearly falls into the category of constrained controls, owing to the finite control effort available to an AUV's thrusters and control surfaces.

The rendezvous problem also falls into the category of optimal control problems with constraints on the final state. Because the objective of rendezvous is for a chaser vehicle to match the position and velocity of a target AUV, the state of the target vehicle represents the specified final state of the chaser vehicle.

The final state is not fixed, since the target vehicle is in motion. Instead there is a "target set" of states as a function of time. Additionally, because the final time for the problem is yet to be determined, this problem is also classified as one having an open final time.

Finally, the rendezvous problem will be shown to have a singular solution.

B. THE AUV EQUATIONS OF MOTION

The equations of motion for the ARIES AUV describe its three-dimensional dynamics and kinematics. The pertinent aspects of AUV rendezvous involve motions in the horizontal plane, since vertical distances between vehicles, typically a few meters, are insignificant when compared to horizontal distances measured in hundreds or thousands meters. Because distance between vehicles is dominated by horizontal plane motion, and because there is insignificant cross-coupling between ARIES horizontal and vertical plane motions, only the horizontal plane is addressed in this work. The horizontal plane

motions of interest are steering, as controlled by the vehicle's rudders, and surge, as controlled by the vehicle's thrusters.

1. Steering Equations

The linearized equations of motion for steering (Healey, 1995) are of the form:

$$\mathbf{M}\dot{\mathbf{x}} = \mathbf{A}\mathbf{x} + \mathbf{B}u \quad (3.7)$$

Where \mathbf{M} is the mass matrix, \mathbf{A} is the dynamics matrix, and \mathbf{B} is the control distribution matrix. Premultiplying both sides by \mathbf{M}^{-1} results in the set of equations for $\dot{\mathbf{x}}$ in the standard state-space form needed to solve the optimal control problem. The ARIES equations, assuming constant forward velocity u and using values determined by (Johnson, 2001) are:

$$\begin{bmatrix} \dot{v} \\ \dot{r} \\ \dot{\psi} \end{bmatrix} = \begin{bmatrix} -0.149 & 0.890 & 0 \\ -0.051 & -0.411 & 0 \\ 0 & 1 & 0 \end{bmatrix} \begin{bmatrix} v \\ r \\ \psi \end{bmatrix} + \begin{bmatrix} 0.153 \\ -0.165 \\ 0 \end{bmatrix} \delta_r \quad (3.8)$$

The states are v , r , and ψ , where v is sideslip velocity in meters per second, r is yaw rate or time derivative of vehicle heading in radians per second, and ψ is the vehicle heading. The control, δ_r , is rudder angle in radians.

2. Simplification of the Steering Equations

In order to examine the optimal control problem in a tractable form, the steering equations were simplified to a single equation. Of the three state variables in the steering equations, the vehicle heading ψ is the most significant in determining vehicle motion. Sideslip velocity v is small compared to vehicle forward velocity u . Additionally, yaw rate r is the time derivative of heading angle ψ . It does not significantly affect other vehicle motions, and its effects are accounted for in ψ .

Assuming that r reaches steady state early in a turn, a reasonable assumption based on ARIES operational data, the steady state version of second equation in Eq. 3.8 becomes

$$0 = -0.051v - 0.411r - 0.165\delta_r \quad (3.9)$$

Operational experience shows that the magnitude of v is generally less than the magnitude of r during a turn. This, coupled with the magnitudes of the coefficients in the first two terms on the right hand side of Eq. 3.8, makes the first term over an order of magnitude smaller than the second term. Disregarding the v term and rearranging the above equation yields a simplified version of equation (3.7)

$$\dot{\psi} = r = k_1 \delta_r \quad (3.10)$$

The result is that, for constant speed, turn rate is proportional to rudder angle and the vehicle's track in a turn is approximately a circular arc. This is a sufficiently accurate approximation for the optimal control solution that follows.

Additionally, over ARIES operational speed range its turning radius is approximately constant. As a result, for a given rudder angle, its turn rate is approximately proportional to u , so for the optimal control solution,

$$\dot{\psi} = ku\delta_r \quad (3.11)$$

3. Surge Equation

The surge equation of motion describes the behavior of u in response to longitudinal forces acting on the vehicle, namely propulsive thrust and drag. Both are quadratic, with thrust proportional to the square of thruster speed N , and drag proportional to the square of u (Triantafyllou, 2002). Taking into account that ARIES always operates with a positive values of u and N , the simplified surge equation is

$$\dot{u} = \alpha N^2 - \beta u^2 \quad (3.12)$$

4. Kinematics

The preceding equations of motion are augmented by kinematic relationships between the state variables to describe motion in the horizontal plane. The coordinate system used is the "North-East-Down" system where X is the northerly coordinate relative to some global origin, Y is the easterly coordinate, and Z is the downward coordinate, all in meters. Since ψ orients the vehicle in the horizontal plane of this coordinate system, and vehicle velocity is predominantly in this direction (disregarding v), the simplified kinematic equations for the horizontal plane coordinates are

$$\dot{X} = u \cos \psi \quad (3.13)$$

$$\dot{Y} = u \sin \psi \quad (3.14)$$

Figure 5 illustrates these variables. The result is a set of four state equations

$$\dot{\mathbf{x}} = \begin{bmatrix} \dot{\psi} \\ \dot{X} \\ \dot{Y} \\ \dot{u} \end{bmatrix} = \begin{bmatrix} ku\delta_r \\ u \cos \psi \\ u \sin \psi \\ \alpha N^2 - \beta u^2 \end{bmatrix} \quad (3.15)$$

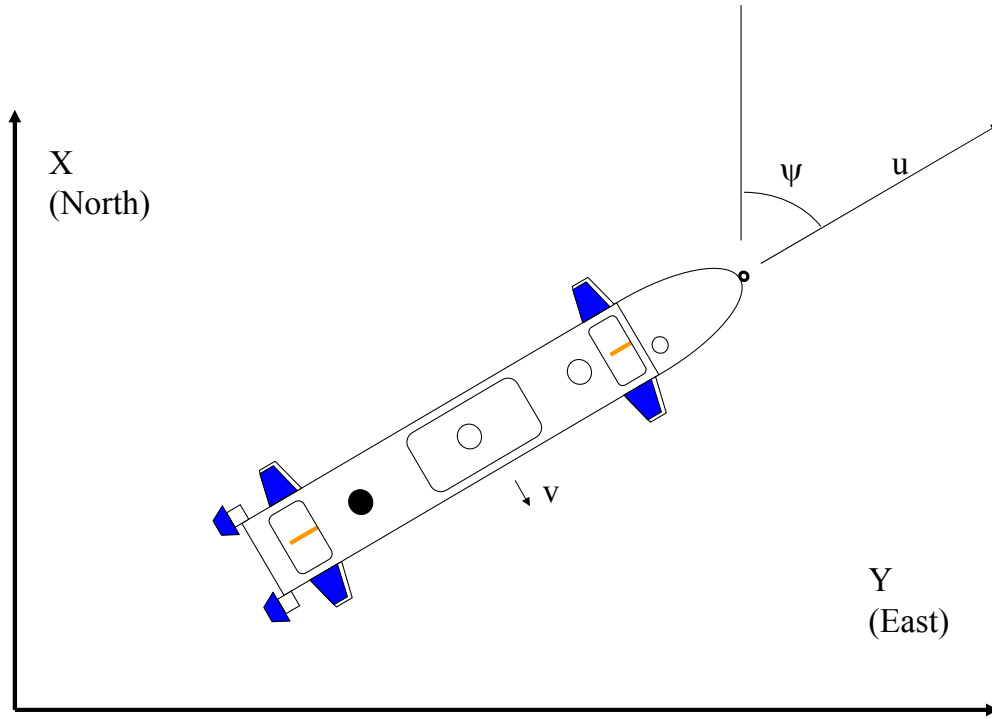

Figure 5. AUV State Variables

5. Result

The result of the above is the following set of expressions for the time optimal control problem. The objective is to find the sequence of control inputs, rudder commands $\delta_r(t)$ and thruster speed commands $N(t)$, which minimize the time until rendezvous. The performance measure is simply

$$J = t_f = \phi(t_f) + \int_0^{t_f} L(x, u, t) dt = \int_0^{t_f} 1 dt \quad (3.16)$$

and the integrand in Eq. 3.1 is unity. The Hamiltonian for this problem is therefore

$$H = 1 + p_1 k u \delta_r + p_2 u \cos \psi + p_3 u \sin \psi + p_4 [\alpha N^2 - \beta u^2] = 0 \quad (3.17)$$

The Hamiltonian equals zero whenever the Hamiltonian is not an explicit function of time and the problem has an open final time (Kirk, 1970). Substituting the Hamiltonian into Eq 3.2 simply yields the state equations Eq. 3.8 again. Substituting into Eq. 3.3 yields the following differential equations for the costates

$$\begin{aligned} \dot{p}_1 &= -\frac{\delta H}{\delta \psi} = u(p_2 \sin \psi - p_3 \cos \psi) \\ \dot{p}_2 &= -\frac{\delta H}{\delta X} = 0 \\ \dot{p}_3 &= -\frac{\delta H}{\delta Y} = 0 \\ \dot{p}_4 &= -\frac{\delta H}{\delta u} = -p_1 k \delta_r - p_2 \cos \psi - p_3 \sin \psi + 2p_4 \beta u \end{aligned} \quad (3.18)$$

Clearly p_2 and p_3 are constants. Inserting these into the first equation and integrating yields

$$p_1 = \int_0^t (p_2 u \sin \psi - p_3 u \cos \psi) dt = p_2 \Delta Y - p_3 \Delta X + p_{1_0} \quad (3.19)$$

which shows that p_1 has a constant value along lines in the horizontal plane corresponding to

$$\psi = \tan^{-1} \left(\frac{\Delta Y}{\Delta X} \right) = \tan^{-1} \left(\frac{p_3}{p_2} \right) \quad (3.20)$$

where ΔY and ΔX denote the change in vehicle X and Y coordinates since the start of the problem.

C. TIME-OPTIMAL SOLUTION FOR CONSTANT SPEED

As a step towards determining the time-optimal solution, we first examine the case of a constant speed vehicle transitioning from a prescribed initial state to a prescribed final state in the shortest possible time. For simplicity, the value of u is fixed at 1 meter per second and maximum magnitude of rudder control is fixed at 1 unit. With no speed dynamics included, the final equation in Eq. 3.15 and 3.18 are removed. Initial vehicle position is at the origin, and the rudder constant of proportionality k is left unspecified. The problem is illustrated in Fig. 6.

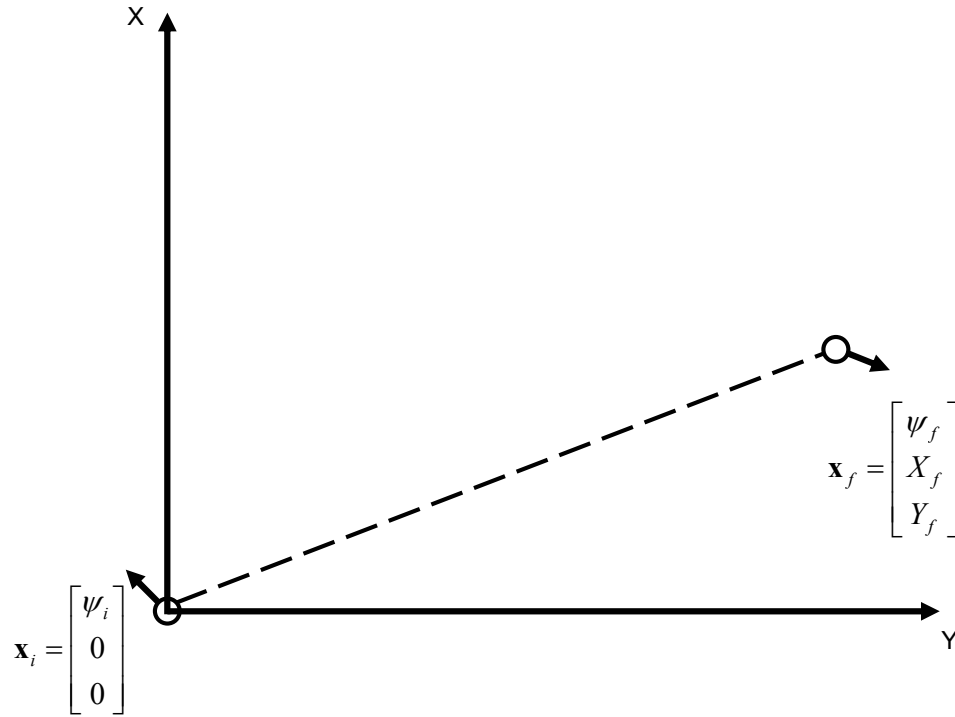

Figure 6. Initial and Final Vehicle Positions

The objective is move from the initial state to the final state in the shortest possible time. The turn radius ρ for a vehicle moving along a circular arc at speed u and yaw rate $\dot{\psi}$ is

$$\rho = \frac{u}{\dot{\psi}} \quad (3.21)$$

In the limit as the rudder constant of proportionality k approaches infinity; ρ approaches zero, yaw rate $\dot{\psi}$ approaches infinity and this problem devolves to finding the shortest transit between the two points. At fixed speed, the solution is the well known straight line connecting two points in Euclidean space. This trajectory requires a constant course between the two points between initial and final turns, which in turn requires a constant zero rudder command. The constrained controls in this example invoke Pontryagin's minimum principle, which requires minimization of the Hamiltonian at each moment in time. The Hamiltonian for the constant speed case is

$$H = 1 + p_1 k \delta_r + p_2 \cos \psi + p_3 \sin \psi \quad (3.22)$$

and minimization involves finding the control δ_r at each moment that minimizes H . The coefficient of δ_r , namely $p_1 k$, is known as the "switching function" since minimizing H involves always switching δ_r to its maximum value opposite in sign to the switching function to make the value of the complete term $p_1 k \delta_r$ as small as possible at every point in time. Such full application of available control is commonly referred to as "bang".

Clearly the straight-line solution is not possible if the rudder is not zeroed. Zeroing the rudder occurs if the value of the switching function is zero itself, such that rudder angle no longer directly affects the value of the Hamiltonian. Such a situation is referred to as "singular", and occurs here for $p_1 = 0$. As discussed previously, straight lines of constant p_1 exist in the plane, so the optimal control solution to this problem has the constants p_1 , p_2 , and p_3 set to values which result in $p_1 = 0$ on the line between these two points. The solution is referred to as "bang-singular-bang", a straight transit between two maximum rudder turns.

Because the switching function equals zero on the singular arc, the control history for rudder commands cannot be determined as the sequence which minimizes the Hamiltonian. Other means must be employed, and one common method is to note that if the switching function is to equal zero for the non-zero duration of the singular arc, its

time derivatives must also equal zero during that period. From Eq. 3.18 the derivative of the rudder switching function is

$$\dot{p}_1 = p_2 \sin \psi - p_3 \cos \psi \quad (3.23)$$

Since the only variable on the right hand side is ψ , it must remain constant if \dot{p}_1 is to remain equal to zero such that p_1 remains constant and equal to zero. This implies constant ψ , which by Eq. 3.23 implies zero rudder during the singular arc, as would be expected.

As the value of k is reduced to reasonable values, the turn radii increase to finite values and curved portions appear on the ends of the trajectory. However, the form of the solution is unchanged. The situation is illustrated in Fig. 7. The singular arc still exists in the middle of the trajectory, along a new line of $p_1=0$ as determined by the problem boundary conditions.

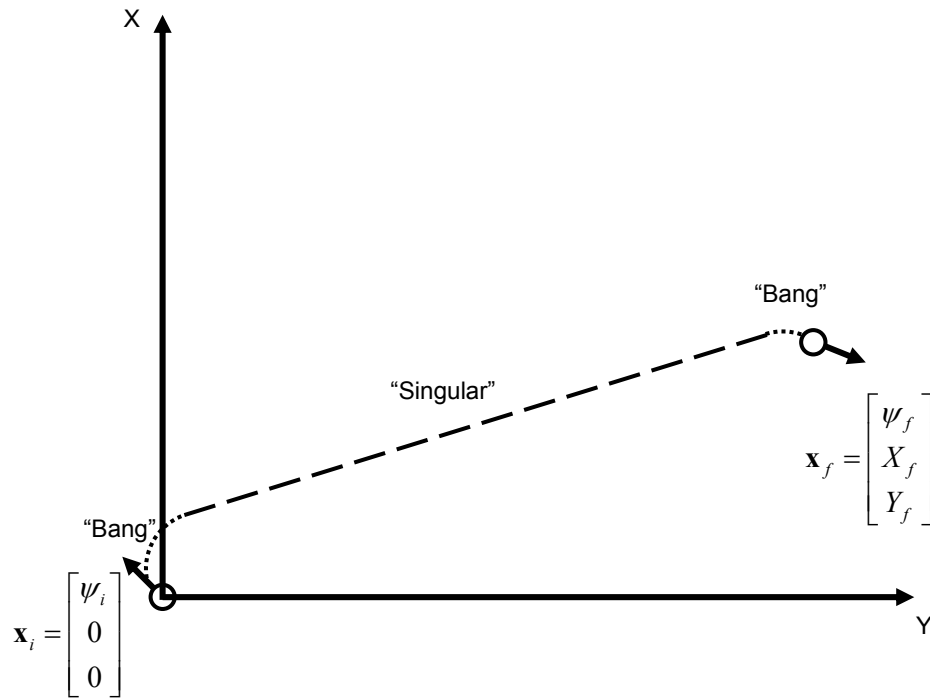

Figure 7. Time Optimal Trajectory, Constant Speed

This result is confirmed by work on Dubins sets in the field of optimal path planning (Shkel and Lumelsky, 2001). This work involves finding the shortest possible path between two points when each point has an associated heading, with a maximum limit imposed on path radius of curvature. These conditions equate to the boundary conditions and control constraints of the previous problem. The optimal path of shortest distance, in cases when the distance between the two points was large compared to the radius of curvature, is a trajectory consisting of a minimum-radius curve followed by a straight segment followed by a minimum radius curve. The Dubins result is shown in Fig. 8.

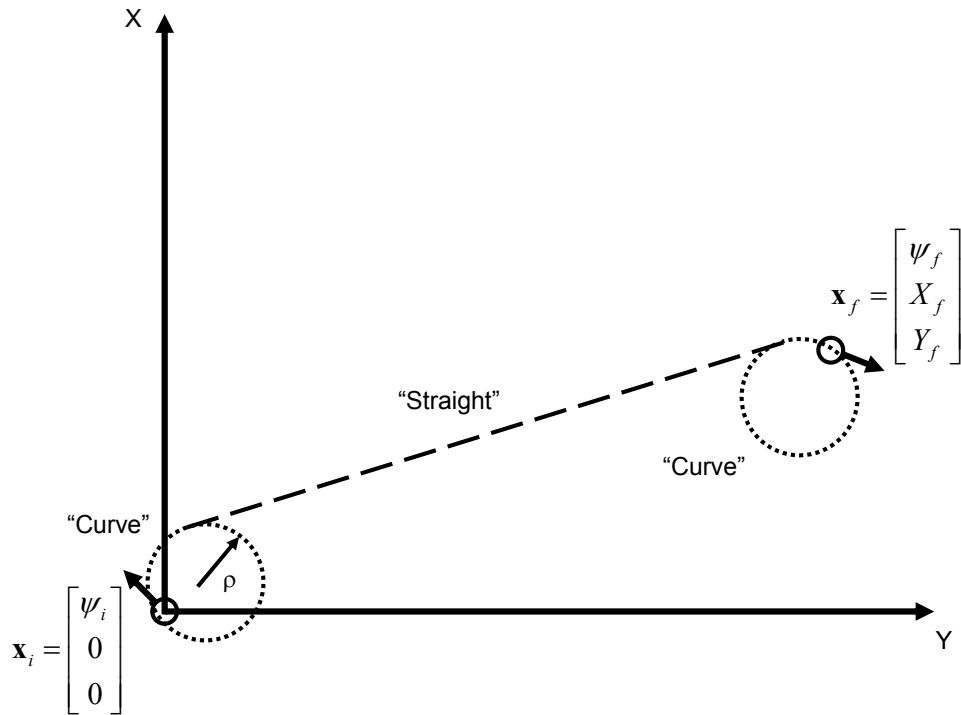

Figure 8. Dubins Solution

D. TIME-OPTIMAL SOLUTION FOR VARIABLE SPEED

Having characterized the time-optimal rudder control, the problem is now generalized to include variable vehicle speed. The problem is illustrated in Fig. 9, where all four vehicle states apply and the vehicle goes from zero initial speed to a final speed u_f .

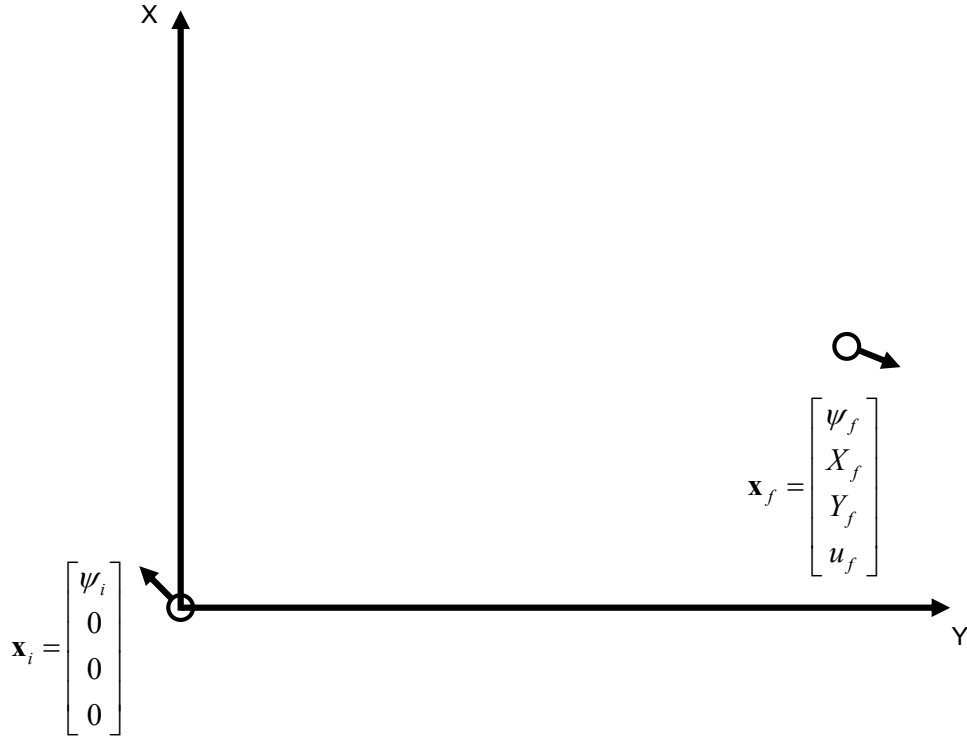

Figure 9. Initial and Final States, Variable Speed

The variable-speed Hamiltonian is

$$H = 1 + u(p_1 k \delta_r + p_2 \cos \psi + p_3 \sin \psi) + p_4 [\alpha N^2 - \beta u^2] \quad (3.24)$$

The Hamiltonian is now to be minimized by the action of two controls, the rudder angle δ_r and thruster speed N . Note that since thruster speed is a squared term and the speed switch is p_4 , the Hamiltonian is minimized by maximizing thruster speed whenever $p_4 < 0$ and by stopping thrusters when $p_4 > 0$. Initially, since $u_i = 0$ and $H=0$, p_4 must be less than zero and full thruster speed is ordered to set the vehicle in motion. As the vehicle begins to move and turn, the middle term responds as it did in the constant-speed case to minimize the Hamiltonian. The path is identical to the constant speed case.

The speed switching function is p_4 , which starts negative. From Eq. 3.18, its dynamics are governed by

$$\dot{p}_4 = -p_1 k \delta r - p_2 \cos \psi - p_3 \sin \psi + 2 p_4 \beta u \quad (3.25)$$

Since the Hamiltonian equals zero at all times, Eq. 3.22 shows that the sum of the first three terms on the right hand side are equal to 1. With $p_4 < 0$ initially, and $u=0$, the last term starts equal to zero and goes negative. As a result, p_4 starts negative and begins increasing. Were it to go positive it will stay positive. There are two possible outcomes. In the first, the last term goes negative fast enough that p_4 never goes positive. In this case full thruster speed is ordered continuously. In the second, p_4 eventually goes positive and zero thruster speed is therefore ordered to minimize the Hamiltonian. The latter case corresponds to the vehicle accelerating to as high a speed as possible to minimize transit speed, then decelerating to meet the terminal constraint on speed, as would be expected in satisfying the boundary conditions of this problem. This speed control is “bang-bang”, full speed command followed by zero speed command. The former case would correspond to a case where transit time is minimized and target vehicle speed equals maximum chaser vehicle speed.

E. SOLUTION FOR MOVING TARGET BY NUMERICAL METHOD

The above results provide the general characteristics of the solution to the time-optimal control problem for a stationary target vehicle. Because of the general difficulty in obtaining solutions to optimal control problems, a numerical method was used to verify that the solution for the more general case of rendezvous with a moving target was the same.

The analysis was done using the MATLAB FMINCON constrained optimizer. An initial state was defined for the vehicle, as was a target set of final states. Parameters to be optimized were rudder and thruster commands. Thruster and rudder commands were discretized into 50 steps each, for 100 total control inputs. One additional parameter to be determined was the size of the time step, for a total of 101 parameters. The FMINCON optimizer then determined the values of these parameters which resulted in the smallest step size, hence the earliest rendezvous time, subject to the constraint that the final state of the vehicle matched target vehicle state. Each thruster and rudder command was optimized individually to arrive at the earliest possible time at which

vehicle states were matched. The chaser vehicle started at the origin on course North ($\psi=0$) and speed = 1.0 meters per second. The target vehicle started at (100,0) on a southeasterly course ($\psi=0.75\pi$) at speed = 1.0 meters per second. Turn dynamics are

$$\dot{\psi} = \delta_r \quad (3.26)$$

and surge dynamics are

$$\dot{u} = 0.08N^2 - 0.08u^2 = 0.08(u_{com}^2 - u^2) \quad (3.27)$$

where u_{com} represents speed command expressed in meters per second vice thruster speed in RPM. Control constraints limited the magnitude of rudder angle limited to 0.4 radians and speed to a maximum of 1.5 meters per second. These provide chaser vehicle dynamics similar to ARIES.

The problem and results are shown in Fig. 10 through 12.

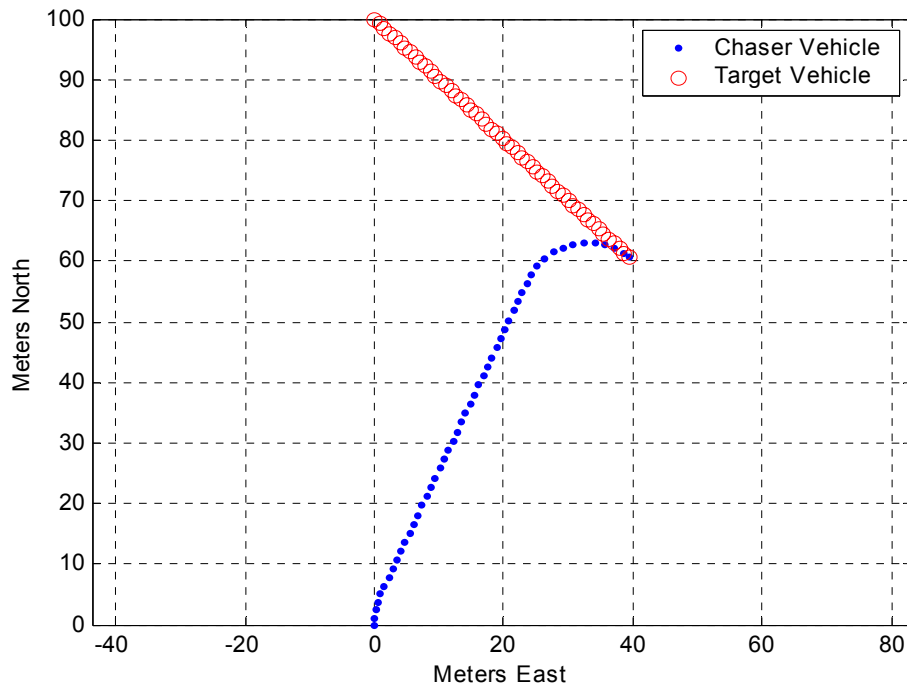

Figure 10. Vehicle Tracks, MATLAB FMINCON Time-Optimal Rendezvous Solution

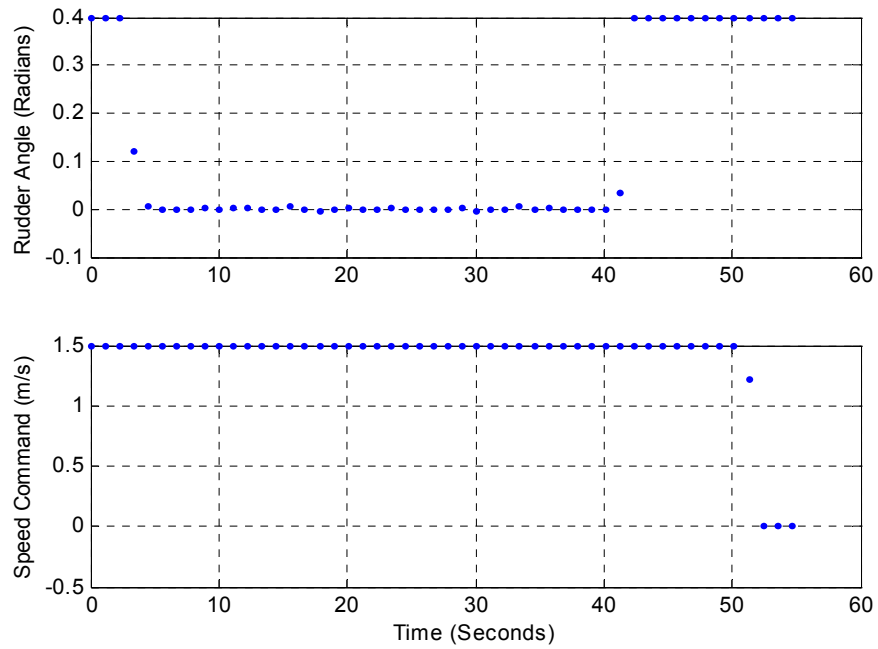

Figure 11. Control Histories, MATLAB FMINCON Time-Optimal Rendezvous Solution

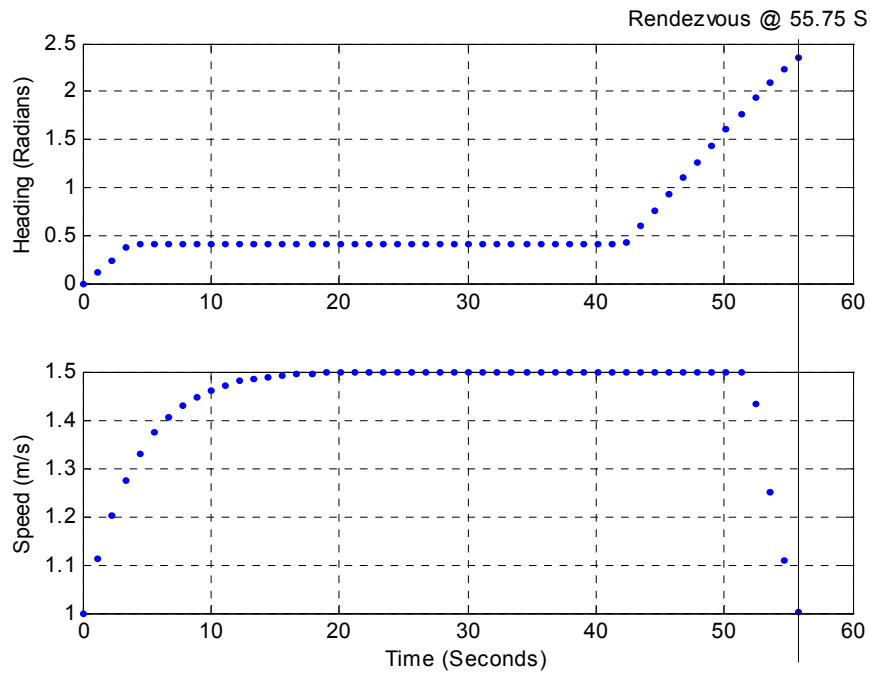

Figure 12. Speed and Heading, MATLAB FMINCON Time-Optimal Rendezvous Solution

Figure 11 shows the control histories for this problem. As discussed previously, rudder control was “bang-singular-bang”, with maximum-effort initial and final turns separated by a singular arc where rudder is essentially zero except for fluctuations due to the singular nature of this part of the problem. Except for one point affected by discretization error, speed control was “bang-bang”. The chaser vehicle accelerated to maximum speed and maintained maximum speed as long as possible, shortening the time until rendezvous. At the speed switch zero speed was ordered, decelerating the vehicle at the maximum possible rate such that vehicle speed, course and position were matched simultaneously.

F. EXISTENCE AND UNIQUENESS OF THE SOLUTION

Existence and uniqueness of the time-optimal solution can be addressed by considering two sets of vehicle states. The set of all possible chaser vehicle states begins as a single point in its state space, its initial condition, and grows as a function of time according to the vehicle’s control history during the time interval. This “set of reachable states” (Kirk,1970), is defined for each future point in time. The target vehicle also has a set of reachable states, but if we assume that it follows a pre-specified trajectory without error its set of reachable states at any time is simply the point it is scheduled to occupy at that time. Figure 13 illustrates this, showing the initial and possible future positions of both vehicles at future points in time, position being a subspace of the state space. Clearly no rendezvous is possible if the target’s state is not a point in the chaser vehicle’s set of reachable states. The time at which the target vehicle’s future position is first included in the chaser vehicle’s set of reachable positions is the first candidate for time-optimal rendezvous, although all other states must be matched as well if rendezvous is to be feasible. The envelope of chaser vehicle reachable positions is defined by its maximum travel from its initial position by that time, which is determined primarily by its maximum speed. Generalizing this to include all states, the earliest time for which the target vehicle’s state is included in the chaser vehicle’s set of reachable states is the earliest time that rendezvous is possible. This defines the time-optimal rendezvous solution.

Assuming the chaser vehicle has a speed advantage over the target vehicle, the solution exists. For no solution to exist the target vehicle must remain outside the chaser vehicle's set of reachable states for all times, which occurs only if its speed exceeds the chaser vehicle, thereby keeping it outside of the chaser vehicle's ever-expanding set of reachable states. The assumption of speed advantage is logical. If chaser vehicle speed did not at least equal target speed, it could not match speed with the target and therefore could not rendezvous with it.

If the solution exists, it is unique. This is so because the target vehicle occupies exactly one position at any given time, and the time to rendezvous is a monotonically increasing function of target progress down track. Were multiple solutions to exist, each would be at a different position and time. Since the value of each time is unique, one would have a unique lower value than the others and would therefore be a unique time-optimal solution.

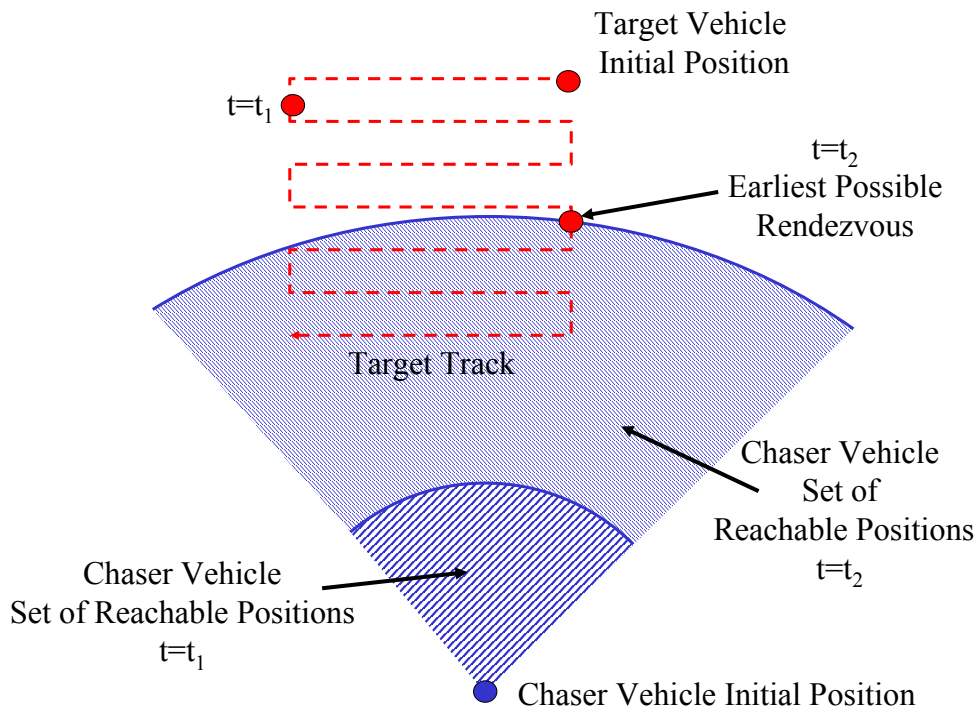

Figure 13. Reachable Positions for Chaser and Target Vehicles

G. SUMMARY

The results of this chapter indicate that the time optimal control history for AUV rudder is “bang-singular-bang”: a maximum-effort turn towards the rendezvous point, followed by a zero-rudder constant heading transit towards the rendezvous point, followed by another maximum-effort turn into rendezvous. Speed control is “bang-bang”: immediate maximum-effort acceleration to maximum speed, followed by a zero-propulsion maximum deceleration to match target speed at the rendezvous point. Control histories such as these can be implemented practically in the ARIES vehicle.

THIS PAGE INTENTIONALLY LEFT BLANK

IV. ENERGY-OPTIMAL RENDEZVOUS

A. OVERVIEW

Along with situations requiring timely rendezvous are situations requiring energy-efficient rendezvous. Present AUVs are energy limited, with the vast majority powered by electric batteries. Propulsion is the largest demand on an AUV's energy stores, a fact driving the development of long-duration glider vehicles. Propulsion demands on a server vehicle operating in a network of multiple sensor vehicles spread over a large area would be significant. In order to conserve server vehicle energy reserves, thereby extending its time on station, it would be advantageous to plan the rendezvous trajectory to be as energy-efficient as possible. This chapter determines the characteristics of energy-optimal AUV rendezvous.

B. AUV POWER CHARACTERISTIC

The same approach as the previous chapter is used here, with the same necessary condition for optimality. The difference for energy optimality is the cost function, which here is the total energy required for rendezvous, defined as the integral of power over time.

The AUV power characteristic is the sum of two terms: "hotel" loads and propulsion loads. Hotel loads are those which are approximately constant over time, such as power for computers and sensors. Propulsion loads are those required to power the vehicle's main thrusters, and are proportional to the product of thrust and vehicle speed. Since thrust is approximately proportional to the square of thruster speed, and steady state vehicle speed is proportional to thruster speed (Triantafyllou and Hover, 2002), a reasonable relationship for vehicle power requirements is

$$P = A + BN^2u \quad (4.1)$$

where P is power in watts, A is hotel load in watts, B is the propulsion power coefficient, and u is present vehicle speed. N is thruster speed command expressed as steady-state vehicle speed in meters per second. In steady state this becomes

$$P = A + BN^3 = A + Bu^3 \quad (4.2)$$

To define the cost function for the ARIES vehicle, its values of A and B had to be determined. This was done by installing an electrical current sensor in its power circuitry and logging vehicle power requirements as a function of speed, including zero-speed measurements of hotel loads. The data is shown in Fig 14.

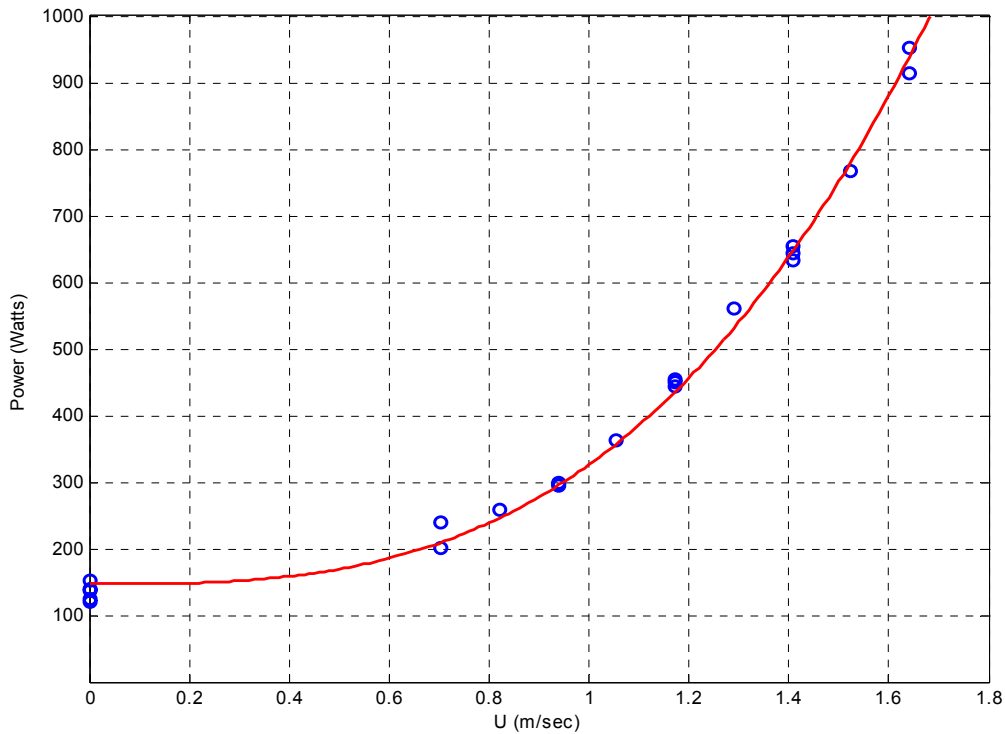

Figure 14. ARIES Power Characteristic

Fitting the parameters A and B to this data and substituting into Eq. 4.2 yields, for steady state operation

$$P = 147.0 + 179.1u^3 = 147.0 + 179.1N^3 \quad (4.3)$$

C. USABLE SPEED RANGE

Figure 14 shows that power measurements were taken for conditions of no propulsion and for propulsion in the upper end of ARIES' speed range. The lack of data

between 0 and 0.7 meters per second is due to a practical limit on minimum speed for ARIES and many other AUVs.

Low-speed operation is restricted by vehicle control considerations. Vehicles such as ARIES that use control surfaces vice thrusters to maintain attitude and depth require forward speed through the water to generate control surface forces. Below a minimum threshold speed vehicle control is lost, so operations are limited to speeds greater than this threshold.

A more significant effect is the tendency to ballast AUVs to be positively buoyant, a practice that assures eventual return to the surface and vehicle recovery in nearly all circumstances. This is particularly desirable considering the cost and complexity of typical AUVs. Any deviation from neutral buoyancy introduces a buoyant force that must be overcome by forces generated by control surfaces, which is not possible below a certain threshold.

Finally, surface suction forces exist which tend to keep the vehicle surfaced until sufficient control surface forces are generated to overcome suction and the vehicle is able to dive. This occurs both at the start of the vehicle's run and whenever the vehicle returns to the surface to obtain a GPS fix.

The result of the above is a constraint on energy-optimal solutions that vehicle speed be no less than the vehicle's lowest controllable speed. Based on ARIES operational experience, this was established at 1 meter per second.

D. MOST EFFICIENT SPEED

A key aspect of finding the energy-optimal rendezvous trajectory is to identify the most efficient speed. A common definition of most efficient speed is the speed for which the greatest distance is covered per unit energy expended. For vehicles having a power characteristic in the form of Eq. 4.1, the solution (Bongiorno, 1967) is

$$u = \left(\frac{A}{2B} \right)^{1/3} \quad (4.4)$$

However, this is solution applies to transits of unspecified length or transit to a fixed end point, which in this context equates to rendezvous with a stationary target. For rendezvous with a moving target it is necessary to generalize the solution.

The energy optimal rendezvous with a moving AUV must take into account the effect of the target's movement on energy requirements. Figure 15 shows the initial positions of ARIES and a target vehicle, as well as the future positions of the target vehicle as a function of time.

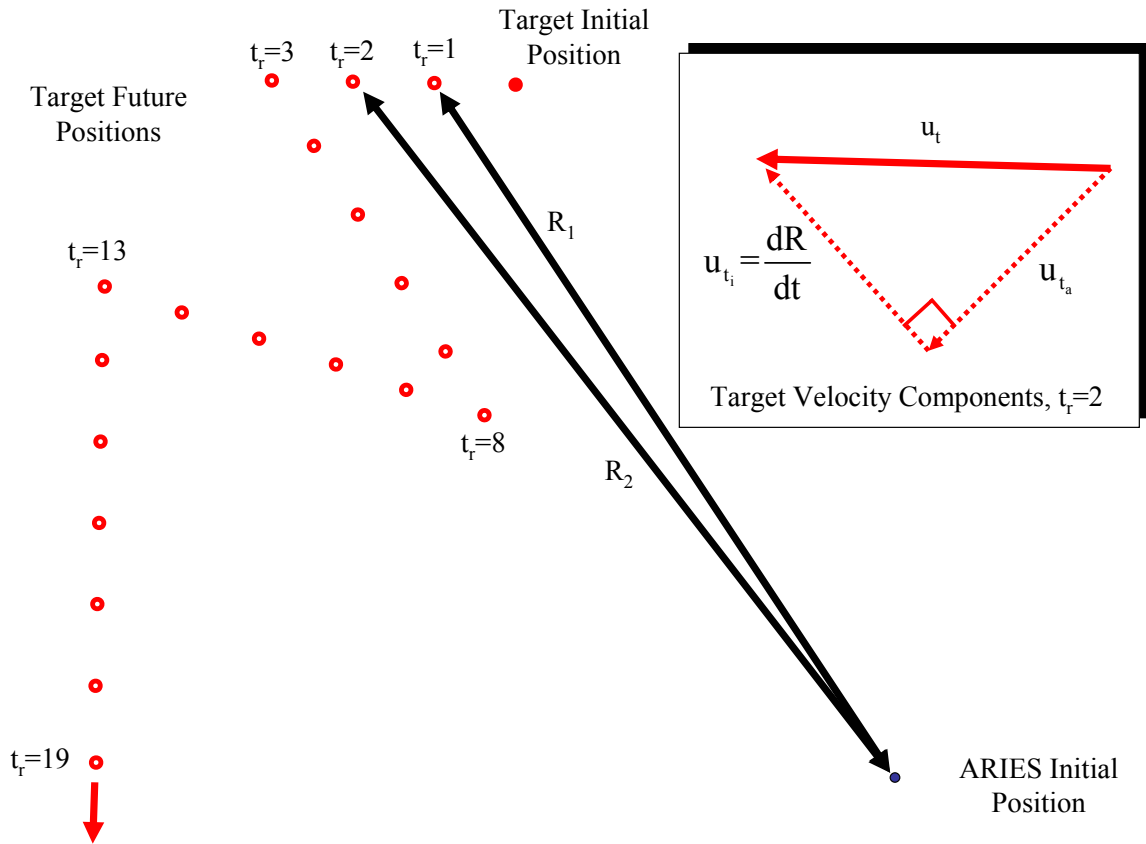

Figure 15. Target Positions and Ranges as a Function of Time, With Decomposition of Target Velocity u_t Into Components Across (u_{t_a}) and Into (u_{t_i}) the Line of Sight

Each future target position is a candidate rendezvous point, with a candidate rendezvous time t_r . Each future position has a range R associated with it, which is the distance from ARIES' initial position to that point. Unlike the time-optimal case, where the optimal rendezvous point was simply the earliest point for which rendezvous is

possible, the location of energy-optimal rendezvous point is less obvious. Assuming that ARIES travels to the rendezvous point along a straight path at constant speed $u(t_r)$, defined as

$$u(t_r) = \frac{R(t_r)}{t_r} \quad (4.5)$$

Figure 15 shows that the value of $u(t_r)$ for the earliest points will be extremely large, as the values of t_r are small. Disregarding the curved ends of ARIES rendezvous trajectory for the moment, the energy E required to rendezvous at target's position at time t_r is equal to power times the time available to transit to that point, or

$$E(t_r) = \left[A + Bu(t_r)^3 \right] t_r = \left[A + B \left(\frac{R(t_r)}{t_r} \right)^3 \right] t_r = At_r + B \frac{R^3(t_r)}{t_r^2} \quad (4.6)$$

A necessary condition for the function $E(t_r)$ to have a minimum is

$$\begin{aligned} \frac{\partial E(t_r)}{\partial t_r} = 0 &= A + \frac{BR^2(t_r)}{t_r^2} \left[-2 \frac{R(t_r)}{t_r} + 3 \frac{dR(t_r)}{dt_r} \right] \\ &= A + Bu^2(t_r) \left[-2u(t_r) + 3 \frac{dR(t_r)}{dt_r} \right] \end{aligned} \quad (4.7)$$

One consequence of Eq. 4.7 is that the most efficient speed is a function of problem geometry. The final term in the equation is the target velocity component in the line of sight, or range rate. Compared to the case of a stationary target discussed previously, the most efficient speed for a target with a negative range rate or closing target will be lower, while the converse is true for an opening target. Note that, for zero range rate, Eq. 4.7 reduces to Eq. 4.4.

A second consequence is that, for the earliest rendezvous opportunity (time optimal rendezvous), $u(t_r)$ will have its maximum value and will drive Eq. 4.7 strongly negative, getting less negative with time as the value of $u(t_r)$ decreases. The result is a

time period early in the problem during which the energy required for rendezvous generally decreases if rendezvous is delayed.

A third consequence is that the minimum-energy point can exist at any time in the problem, complicating the process of finding it. The final term in Eq. 4.7 is determined by the target's heading and speed, both of which can be programmed to change at any time. A change from opening to closing aspect, as occurs at $t_r=3$ in Fig. 15, will cause an immediate drop in the value of Eq. 4.7, which may signal the opportunity for a new minimum, possibly a value lower than previous minima depending on the length of the period of closure. As a result, the energy-optimal rendezvous point is more difficult to locate; and the search for it more extensive than the time-optimal case.

A related consequence is that minima tend to be located at points where the target's aspect changes from closing to opening. This happens either when the target turns away, as occurs at $t_r=8$ in Fig. 15, or for targets on straight paths as they reach the closest point of approach, as occurs at $t_r=19$.

A computer simulation depicted in Figs. 16 and 17 demonstrate the above points. Figure 16 shows ARIES initial position southeast of a target vehicle's operating area. ARIES is to rendezvous with the vehicle, which is running a typical AUV survey pattern along parallel tracks defined by waypoints. The target's speed is constant at 1 meter per second, and ARIES maximum speed is 1.5 meters per second. Figure 17 is a plot of energy to rendezvous as a function of rendezvous time. For each candidate rendezvous point, the energy to rendezvous is calculated using Eq. 4.6. Since the curve is only plotted for points reachable by ARIES at 1.5 meter per second or less, most of the points prior to $t=500$ seconds are not plotted. Early on, energy requirements for the first few points drop with increasing time as discussed above. The curve is highly non-linear, having several maxima and minima caused by target maneuvers, changes in target aspect, and the passage of time. The curve shows that, as the target maneuvers from closing to opening aspect at way point 2, energy required to rendezvous begins to increase, with the opposite occurring as it maneuvers to a closing aspect at way points 3 and 4.

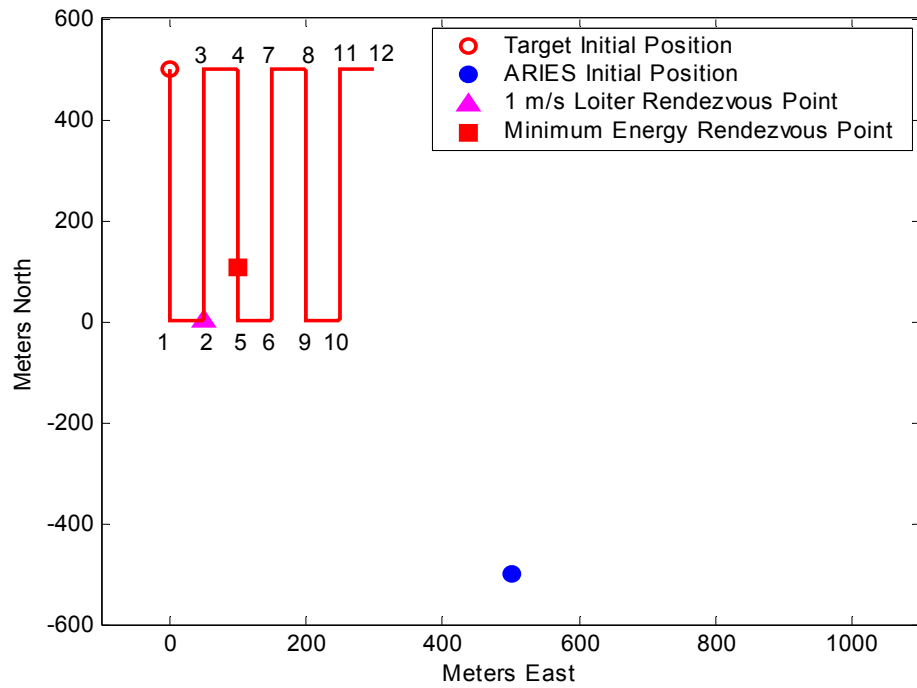

Figure 16. ARIES Rendezvous With Maneuvering Target, Waypoints Annotated

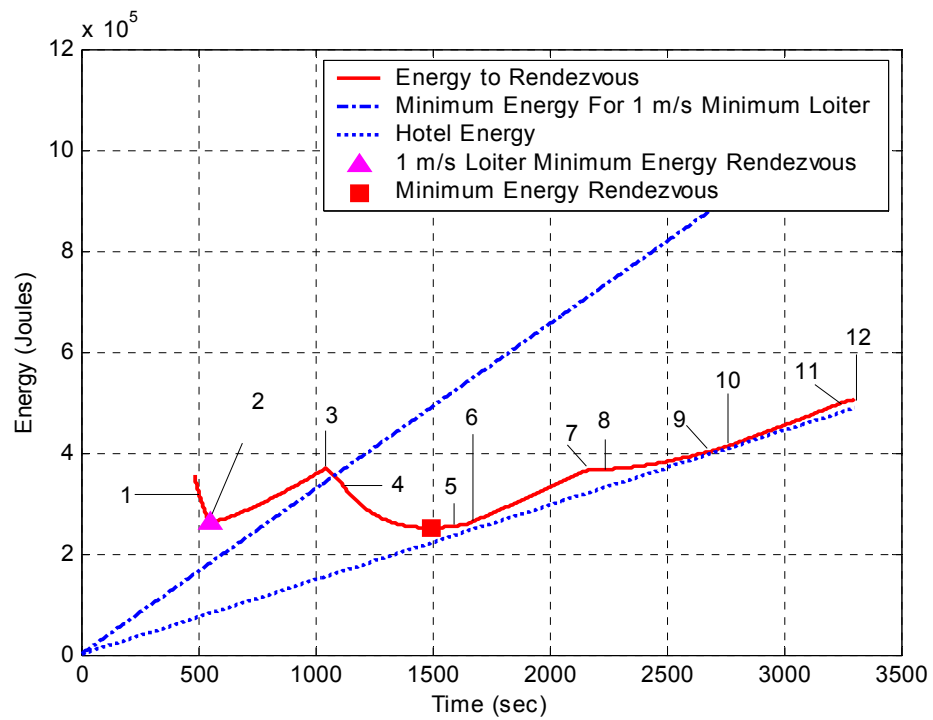

Figure 17. Energy to Rendezvous, as a Function of Time, With Way Points Annotated

Also plotted on Fig. 17 are two limits for minimum possible energy. The upper line is ARIES minimum possible energy expenditure assuming that it must maintain a greater than a minimum controllable speed of 1 meter per second. In this case the lowest power state of the vehicle corresponds to loiter or transit at 1 meter per second. The lower line is the minimum possible energy expenditure if there were no minimum controllable speed. This latter line represents a no-propulsion vehicle state, with only the hotel load.

For the minimum loiter speed case, the energy-optimal rendezvous is defined by the point on the rendezvous energy curve to the left of the minimum energy for minimum loiter line that has the lowest energy value. For this case, the energy-optimal rendezvous occurs at way point 2. ARIES' speed enroute to the rendezvous point in this case was 1.223 meters per second. As discussed above, this is a case where a target maneuver from a closing to opening aspect causes a minimum on the energy curve. Analysis of this rendezvous point showed that it was the point satisfying Eq. 4.7. Rendezvous is still possible for later times, such as way points 4 and later, but would involve ARIES loitering at 1 meter per second and using up unnecessary transit distance while waiting for the rendezvous at the later point.

For the case of no minimum loiter speed, the energy-optimal rendezvous point is simply the global minimum. In this example, the point occurs between way points 4 and 5, and ARIES speed enroute to rendezvous would have been 0.487 meters per second if there were no ARIES minimum speed. This is an example of the other case discussed above: a minimum occurring on a steady course, where the value of Eq. 4.7 passes through zero due to the gradual change in target vehicle aspect as it proceeds down track.

Note that the target maneuver at way point 3 created a global minimum. Had the target not maneuvered and remained on its northerly course, the global minimum would have occurred at way point 2. This illustrates how the energy-optimal rendezvous point is highly dependent on the specifics of the target's track, and the necessity of examining a large portion of its track to identify the energy-optimal rendezvous point.

Note also that for the minimum loiter speed case that the latest possible energy-optimal rendezvous is the first intersection of the energy curve with the minimum energy for minimum loiter line. This is so because the line has a positive slope, therefore any rendezvous after this intersection must involve a greater amount of energy.

Finally, note that in this case of a constantly maneuvering target that its geographic position does not change quickly; it tends to remain in the same geographic area and proceed slowly to the east. As a result, the energy required to rendezvous quickly converges to the hotel load.

E. CHARACTERISTICS OF THE ENERGY-OPTIMAL SOLUTION

The preceding assumed ARIES trajectory to rendezvous was a straight line, disregarding the effects of initial and final course and speed changes necessary to complete an actual rendezvous trajectory as discussed in the previous chapter. The same methods used in the previous chapter are applied here to determine the characteristics of the energy-optimal rendezvous trajectory. What differentiates the two is the cost function $J(\mathbf{x}, \mathbf{u}, t_f)$.

Proceeding as with the time-optimal case, the cost function for the energy-optimal case is the total energy to rendezvous. The problem still features constraints on controls and final state, which is still defined as a target set since final time is still open. It will also be shown to be singular.

The cost function is the integral of power over time, or

$$J(\mathbf{x}, \mathbf{u}, t_f) = \phi(t_f) + \int_0^{t_f} L(\mathbf{x}, \mathbf{u}, t) dt = \int_0^{t_f} [A + BN^2u] dt \quad (4.8)$$

Using this integrand to form the Hamiltonian yields

$$\begin{aligned} H &= [A + BN^2u] + p_1u\delta r + p_2u\cos\psi + p_3u\sin\psi + p_4(\alpha N^2 - \beta u^2) \\ &= (Bu + \alpha p_4)N^2 + p_1u\delta r + A + p_2u\cos\psi + p_3u\sin\psi - p_4\beta u^2 \\ &= 0 \end{aligned} \quad (4.9)$$

The speed switching function is

$$(Bu + \alpha p_4) \quad (4.10)$$

Bongiono (1967) showed that speed control for a non-maneuvering vehicle was singular, and that its value was provided by Eq. 4.4, the most efficient speed for that case. It is also singular here as well, when Eq. 4.10 equals zero. This is expected since energy-optimal rendezvous should involve operation at speeds other than extremes. Substituting the Hamiltonian into the necessary conditions for optimality yields

$$\begin{aligned} \dot{p}_1 &= -\frac{\delta H}{\delta \psi} = u(p_2 \sin \psi - p_3 \cos \psi) \\ \dot{p}_2 &= -\frac{\delta H}{\delta X} = 0 \\ \dot{p}_3 &= -\frac{\delta H}{\delta Y} = 0 \\ \dot{p}_4 &= -\frac{\delta H}{\delta u} = -BN^2 - p_1 k \delta r - p_2 \cos \psi - p_3 \sin \psi + 2p_4 \beta u \end{aligned} \quad (4.11)$$

Again, as in Ch. III, p_2 and p_3 are constants. And again, p_1 has a constant value along lines in the horizontal plane. So rudder control is “bang-singular-bang” in the energy-optimal case as well. Speed control is now “bang-singular-bang”, with N^2 driven to zero for positive values of the switching function, maximum for negative values of the switching function, and the most efficient speed when the switching function equals zero.

F. NUMERICAL SOLUTION

The same scenario run in Ch.III was run for the energy-optimal case. The results are shown in Figs. 18 through 20. Rudder and speed control are “bang-singular-bang”. Starting from an initial speed of 1.0 meters per second, the initial speed order is essentially zero for the first time step, decelerating the vehicle to 0.876 meters per second. Speed command is held there until the final time step before rendezvous, where it is increased to match target speed of 1.0 meters per second at rendezvous, which occurs at 88.76 seconds.

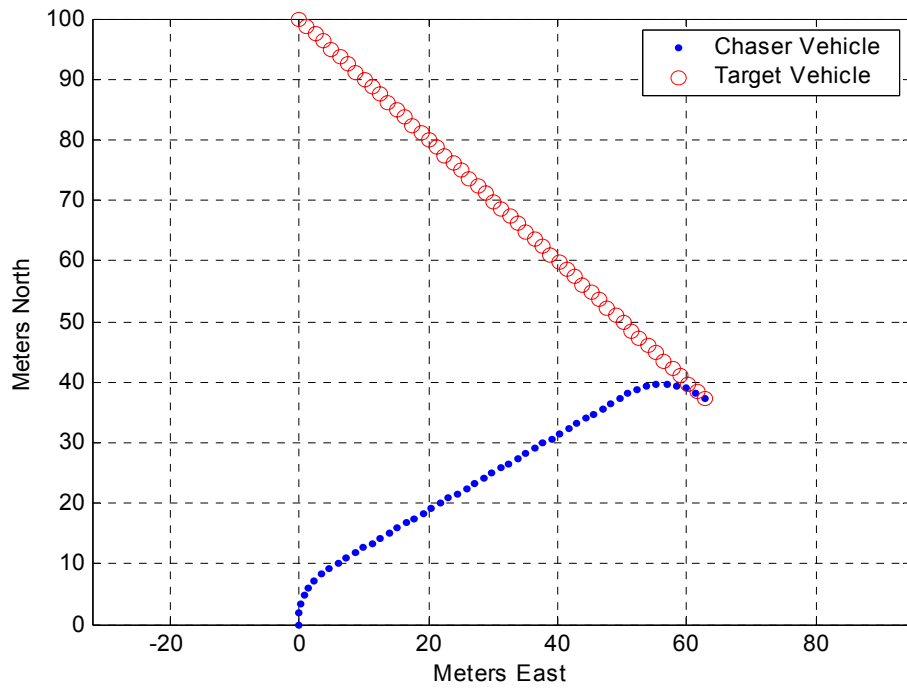

Figure 18. Vehicle Tracks, MATLAB FMINCON Solution to Energy-Optimal Rendezvous

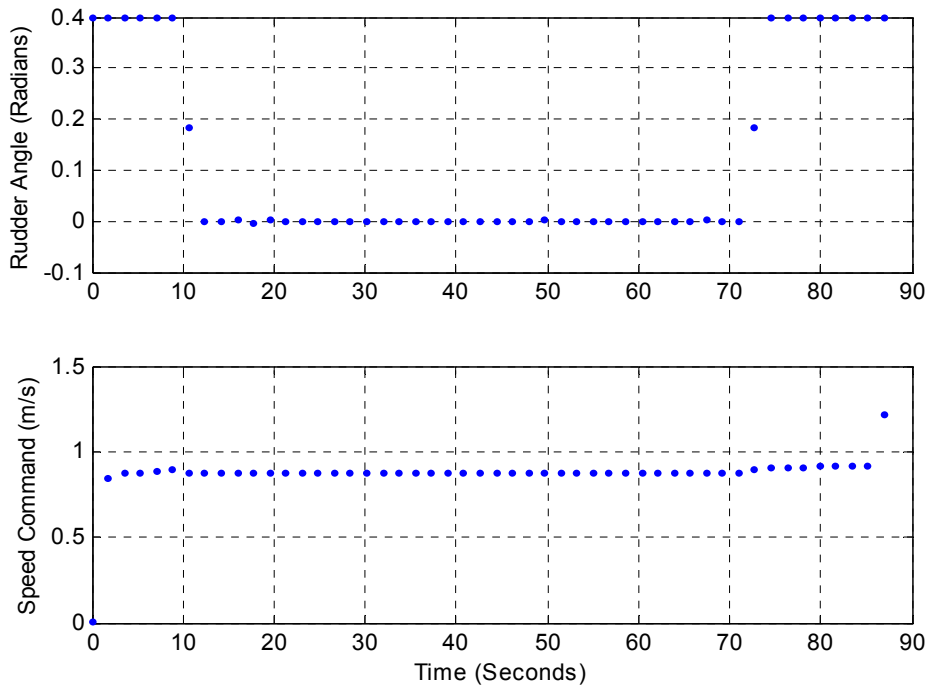

Figure 19. Control Histories, MATLAB Solution to Energy-Optimal Rendezvous

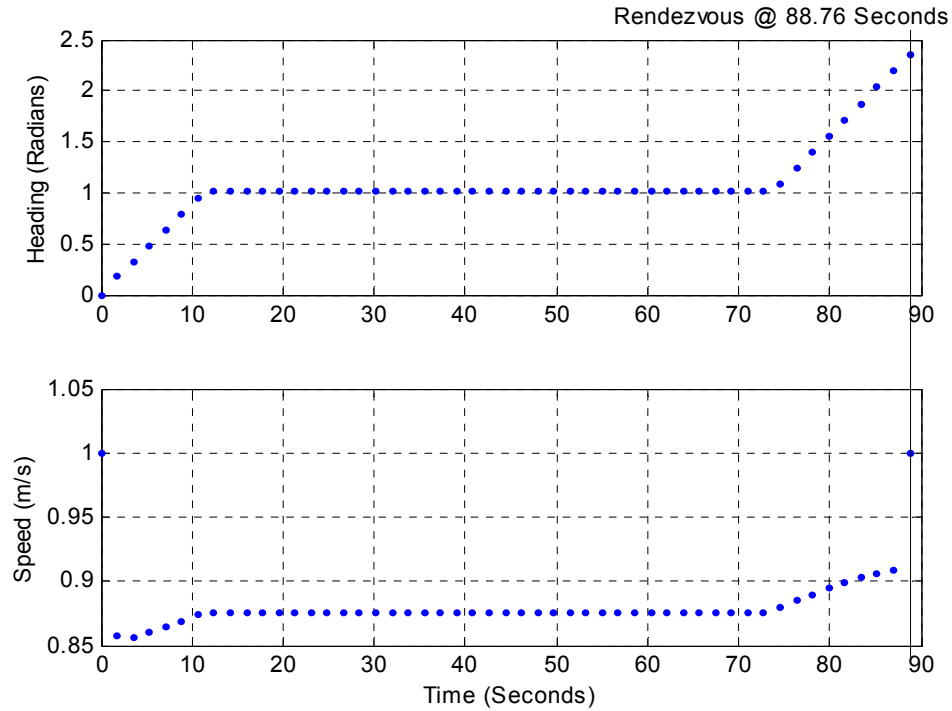

Figure 20. Speed and Heading, MATLAB Solution to Energy-Optimal Rendezvous

G. EXISTENCE AND UNIQUENESS OF THE SOLUTION

As was the case in Ch. III, the rendezvous solution exists when the chaser vehicle has a speed advantage over the target.

The solution is not necessarily unique, however. Considering Fig. 17, it is possible that target vehicle maneuvers could produce several identical energy minima. In such cases, considering the nature of rendezvous operations, it would be advantageous to select the earliest such minimum. This will be the approach taken for implementation in ARIES.

H. SUMMARY

Energy-optimal rendezvous involves “bang-singular-bang” control of both rudder and speed. The shape of the trajectory is similar to the time-optimal track, with maximum-rudder initial and final segments bracketing a straight singular section. A singular arc is also contained in the speed control history, where the speed commanded is the most efficient speed for the particular problem.

V. IMPLEMENTATION OF AUV RENDEZVOUS

A. OVERVIEW

The time optimal and energy optimal AUV rendezvous trajectories derived in Ch. III and IV were implemented in the NPS ARIES vehicle, a test bed for investigating new AUV capabilities and behaviors. Originally designed to serve as a communications node for a network of AUVs, it was well suited for this demonstration.

The essential aspects of the optimal control solutions obtained in the previous chapters were adapted for implementation in ARIES, with modification to provide the necessary efficiency and robustness for this implementation.

B. IMPLEMENTATION OF OPTIMAL CONTROLS

The previously-derived optimal controls solutions can be summarized as a set of rules which a planning process must observe in order to approximate the optimal controls for AUV rendezvous. For time optimal rendezvous, the rules are:

- Bang-bang speed control: Accelerate immediately to maximum speed, holding maximum speed as long as possible without overshooting the final rendezvous state, decelerate using minimum propulsive power to match target speed when both vehicles arrive simultaneously at the arrival point.

- Bang-singular-bang rudder control: Immediately make an initial maximum-rudder turn to the closing course, maintain constant course (zero rudder) as long as possible without overshooting the final rendezvous state, then make a final maximum-rudder turn to rendezvous course, timed to match target course when both vehicle arrive simultaneously at the arrival point.

For energy-optimal rendezvous the rules are:

- Bang-singular-bang speed control: Immediately change speed to the most efficient speed for the scenario, hold this speed as long as possible without overshooting the final rendezvous state, then change speed to match target speed when both vehicles arrive simultaneously at the arrival point.

- Bang-singular-bang rudder control: Same as time-optimal case.

These essential aspects of the optimal control solutions were implemented in the ARIES mission planning process. In order to avoid convergence problems and to conserve ARIES' computational resources, the ARIES planning process was not written as a large-dimension parameter optimizer as was used in Ch. III and IV. Instead, these aspects of the optimal solutions formed a set of rules to be observed by a trajectory planning routine which applied them in searching for the minimum-time or minimum-energy rendezvous trajectory for the vehicle states at the time of planning.

The previously-derived optimal controls represent typical solutions to such optimal control problems: determined by the initial state of the system, the parameters of the system, and perfect information about both. Such solutions are completely determined at the start of the problem. For a given system, the trajectory is determined by the initial conditions and no adjustment or feedback is required during the problem run, hence the "single sample" or "open-loop" description of such problems. The AUV optimal controls previously presented do not account for such real-world phenomena as imperfect target and chaser vehicle state information, such as courses, speeds, and positions. Nor do they account for unpredictable disturbances such as variations vehicle dynamics parameters or currents and weather. These effects cause the optimal control solution to degrade over time as errors propagate, disturbances affect the system, and updated information becomes available. To counter these degradations, it is necessary to periodically re-evaluate the status of the rendezvous and to replan it based on updated information.

C. CONCEPT OF OPERATIONS

In order to proceed with development and implementation of the rendezvous behavior, it was first necessary to establish several planning assumptions to guide software development. They specify realistic constraints to be addressed in rendezvous software.

1. Network Comprised of One Server and Multiple Sensor Vehicles

One server vehicle acts as a central communications node for a network of sensor vehicles. It downloads data from these vehicles during rendezvous, and later uploads this data to the next communications node. The area of operations is divided into zones.

Each zone contains one sensor vehicle, carrying a sensor payload used to gather the desired data in this zone. Examples of such data include locations of threats such as mines or obstacles, or time-sensitive information on the activities of an opposing force.

2. Server Vehicle Knowledge of Sensor Vehicle Mission

Assuming the same operator controls all vehicles in the network, it is reasonable to assume that essential elements of the sensor vehicles' mission can be made available to the server vehicle prior to the start of the operation. Such information includes positions of intended waypoints and vehicle speed along each mission leg. This is data that would not be expected to change during the operation, and providing such data to the server vehicle a priori reduces the amount of data that must be communicated between vehicles to plan a rendezvous. Other aspects of the mission, such as actual target vehicle position, might vary in response to effects such as currents and other uncertainties. As a result, some information must be exchanged between vehicles in order to rendezvous.

3. Default Server Vehicle State = Loiter

The server vehicle loiters in a specific location. When pursuing a rendezvous it departs the loiter area for the operating area of one or more sensor vehicles, and returns to the loiter area once all rendezvous are complete. This allows selecting a loiter area to optimize communications and transit paths between vehicles.

4. Minimal, Dual-Mode Communications

Covertness, as well as reducing network traffic, requires minimizing the volume of inter-vehicle communications. This is achieved through a dual-mode communications scheme. A command-and-control mode consisting of a long-range, high-reliability, low data rate mode is used for long-range communications between vehicles to request and coordinate the rendezvous process. The volume and length of these transmissions is minimized to improve covertness and to minimize network traffic. A rendezvous mode consisting of a short-range, high data rate mode is used during rendezvous to pass data from sensor to server vehicle. The short-range nature of this mode provides covertness.

5. Rendezvous in Response to Sensor Vehicle Request

The server vehicle will rendezvous with sensor vehicles in response to their requests, as opposed to rendezvous with sensor vehicles on a pre-determined schedule. Requests are transmitted by sensor vehicles when their logic indicates that a significant,

time-sensitive, reportable event has occurred. This scheme simplifies server vehicle operations in that it minimizes server vehicle movements, reducing total propulsion energy required. Also, if the loiter area optimizes communications, loitering in this area except when conducting rendezvous improves the likelihood that the vehicle will be in this location, thereby improving communications reliability.

6. Vehicle Network Operates Asynchronously

Because the server vehicle responds to rendezvous requests from sensor vehicles, which may request rendezvous at any time, the network necessarily is asynchronous. The handling of rendezvous requests in server vehicle software must ensure that requests are properly queued and that information contained in queued requests is updated when updates become available.

7. Sensor Vehicle Does Not Maneuver for Rendezvous

Sensor vehicles perform their missions throughout the operation of the vehicle network, including rendezvous for data transfer. The sensor vehicle does not deviate from its mission profile to facilitate the rendezvous. The server vehicle performs all rendezvous calculations and maneuvers to satisfy the rendezvous optimization objective. An important implication of this is that the sensor vehicle's speed must not exceed the server vehicle's speed at any time. Were this not true, the server vehicle would need to alter its operations by slowing down to permit the server vehicle to rendezvous. A more general implication is that sensor vehicle dynamic characteristics must not exceed those of the server vehicle to a degree that rendezvous may be disrupted. The detailed dynamic limits would be dependent on the rendezvous communications method. An example would be a sensor vehicle whose turn rate so exceeds the server vehicle's that rendezvous communications between vehicles is significantly disrupted. A directional optical method might impose stringent limitations on vehicle turn rates and other dynamics to ensure that the directional sending / receiving devices stay aligned during rendezvous. However a more omni-directional acoustic method might only require that vehicles remain within its maximum range capability during maneuvers, permitting divergent turn rates and courses so long as they do not result in exceeding this maximum range. In summary, we assume that vehicle dynamics are controlled such that they cannot disrupt a rendezvous in progress.

8. Vehicles Maintain Ground Track and Speed Through Water

In the presence of currents, AUVs can be expected to be set away from their intended track over ground. The usual response to this effect is for the AUV to adjust its heading and assume a “crab angle” to counter the effect of currents. Ground track is maintained, although speed over ground may be affected. In this implementation, the rendezvous planning process assumes that vehicles subject to currents adjust their courses accordingly. However, they are assumed to maintain their pre-planned speed through the water while doing so, making no adjustment in speed for the effects of currents. This is reasonable since vehicles will frequently operate at a maximum or minimum attainable speed through the water, in which case no increase or decrease in speed may be possible.

9. Optimality

Rendezvous trajectories are to satisfy either a minimum energy or minimum time optimization objective.

10. Robustness

Software must be tolerant of real-world effects such as navigation inaccuracy, communications drop-outs or garbles, or ocean currents.

D. ROBUSTNESS FEATURES

The following features were incorporated into rendezvous management software.

1. Rendezvous Queue Management

The asynchronous nature of the network results in random arrival of rendezvous requests from sensor vehicles. Additionally, a request from one vehicle may arrive while the server vehicle is closing or engaged in rendezvous with another sensor vehicle. Requests are queued for action in order of arrival, with the first request completed in its entirety before the next request is acted upon. Also, since rendezvous requests convey sensor vehicle navigation data which may change significantly while the request is in the queue, sensor vehicles may send subsequent rendezvous requests containing updated navigation data. The queue is managed such that the updated request replaces the previous request for any sensor vehicle in the queue, rather than adding it to the queue as a new rendezvous request. If such a request is received from the sensor vehicle that the server vehicle is enroute to rendezvous with, receipt of the request triggers an immediate replanning of the rendezvous.

2. Missed Rendezvous Logic

Once a rendezvous is planned, the rendezvous process must be able to overcome a failure of rendezvous communications at the rendezvous point. Action must be taken to correct the problem and, if uncorrected, the rendezvous must be terminated so that the server vehicle can break out of this state and proceed with other aspects of its operation. This situation could be caused by a failure of communications equipment, incorrect rendezvous planning by the server vehicle, or by inaccurate navigation or equipment malfunction for either vehicle. In such instances, the server vehicle first queries the sensor vehicle to report its present navigation data so that another rendezvous can be planned. If no response to this query is received, the server vehicle abandons the rendezvous and deletes the rendezvous request from the queue.

3. Rendezvous Request Check Sum

One possible cause of the above missed rendezvous scenario is the possibility that garbled navigation data contained in the rendezvous request results in the incorrect planning of a rendezvous, with the server arriving at an erroneous rendezvous point. To prevent this occurrence, rendezvous requests contain check sums to improve the probability of correct receipt of rendezvous request navigation data.

4. Mission Feasibility Check

To guard against other unforeseen causes of incorrect rendezvous planning, the final results of the rendezvous mission generated by the mission planning process is checked for feasibility of waypoint positions. A navigational envelope is defined around the area of operations which contains all expected sensor vehicle positions during the operation. If any of the waypoints contained in the rendezvous mission generated onboard ARIES fall outside of this envelope the mission is deemed infeasible and is not acted upon unless a subsequent rendezvous request containing corrected sensor vehicle position data is received.

5. Currents

Because currents can significantly affect navigation accuracy, the rendezvous planning process accepts set (direction) and drift (magnitude) of currents as inputs and accounts for their effects on vehicle speeds and headings in planning rendezvous missions.

6. Navigation Accuracy

Because ARIES fixes its position by surfacing for GPS fixes, it can only fix its position periodically, generally once every few minutes. The remainder of the time it uses speed and heading sensors to dead reckon its position. Sensor errors lead to position errors that grow over time. Additionally, it is reasonable to expect that sensor vehicles are affected similarly, and will periodically update their reported positions. To account for these effects and update the rendezvous solution, rendezvous missions are periodically replanned while in progress.

E. BASELINE ARIES CHARACTERISTICS

The NPS ARIES vehicle is a shallow-water AUV used as a test-bed to explore new concepts for autonomous vehicles. As such, its hardware and software are frequently modified. The following description applies to its “baseline” or normal configuration, prior to modification for rendezvous operations.

1. Hardware

Key components are shown in Fig. 21. ARIES is powered by 6 lead-acid batteries which provide several hours worth of power. Propulsion is provided by two fixed stern-mounted thrusters and vehicle attitude is controlled by two bow planes, two stern planes and two top-mounted rudders. It navigates by fusing a variety of navigation sensors; including compasses, velocimeters, gyros, an inertial measurement unit, and a GPS receiver which provides fix information whenever the GPS antenna is out of the water and exposed to the GPS satellite constellation. The present sensor configuration consists of a video camera and supporting storage, processing, and transmission equipment, although various sonar systems have also been carried. Because of its design as a communications node, ARIES carries both radio and acoustic communications equipment. For the implementation of AUV rendezvous the key piece of communications equipment was the Benthos acoustic modem, which has been used for previous communications research (Marr, 2002) and which enables communications between submerged vehicles. Its capabilities were adequate for command and control communications such as sending and receiving rendezvous requests and for reporting

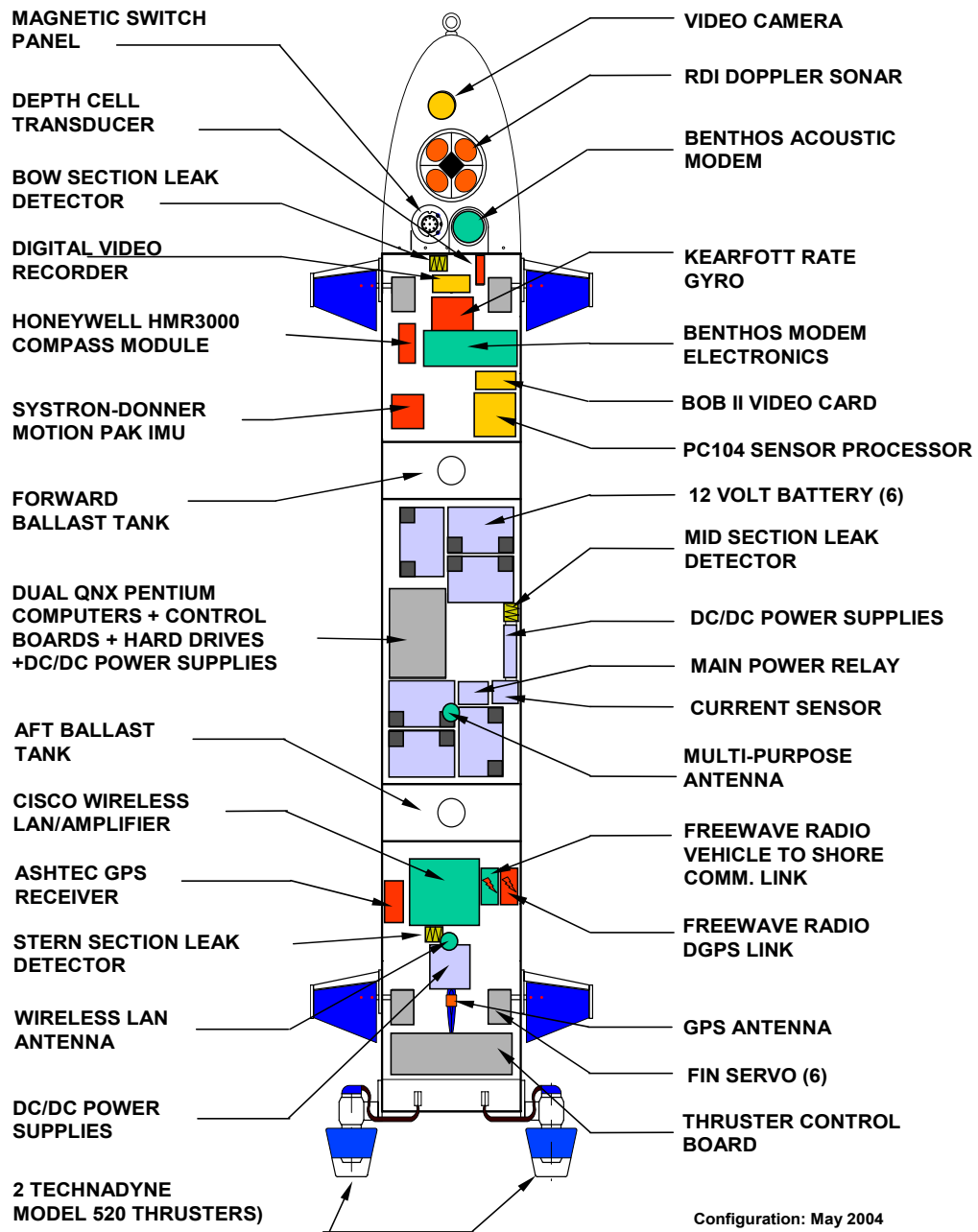

Figure 21. ARIES Vehicle Diagram (After: Marco, 2001)

vehicle status. No hardware modification, other than addition of the electrical current sensor used to measure ARIES' power characteristic function, was necessary.

ARIES' operation is controlled by a dual processor computer. Each processor consists of a Pentium 166MHz CPU on an EBX motherboard, each hosting various PC-104 input/output cards. Both processors run the QNX 4.23a real-time operating system. Communications between processors and to other computers is via a 10Base2 Ethernet connection. An additional connection to the processor designated QNXE is provided via FreeWave radio modem. This connection is used during ARIES operations when ARIES is not physically connected to an Ethernet cable, and permits command and control of the vehicle while it is on the surface.

2. Software

The baseline ARIES software architecture is as shown in Fig. 22. The primary function of the processor designated QNXT is navigation. It hosts several processes, most of which process data from navigation hardware. Associated with each process are shared memory blocks where processed data is written for reading by the Nav process. The Nav process uses an extended Kalman filter to fuse sensor data into accurate navigation data. QNXT also hosts processes for overlaying navigation data onto video images (Bob II), for digitizing analog signals from navigation equipment and other vehicle systems (Analog), and for transmitting navigation data to QNXE (QtS).

QNXE controls vehicle mission execution. It receives the navigation data supplied by QNXT via the network process QeR and, using various sliding mode autopilots, sends commands to ARIES' six control surfaces to maintain course and depth. The mission is described in the mission script file, which could contain a sequence of low-level commands such as thruster speeds, control surface angles, headings, depths, or altitudes to be executed. However, usual ARIES missions are described at a higher level. Rather than specifying the low-level details of the mission, the script file typically calls for a "waypoint control" mission. In this case, a second file which describes the mission as a series of navigation waypoints is read into the Exec process at the start of the mission. Each line of this file specifies the position of the next waypoint, as well as the

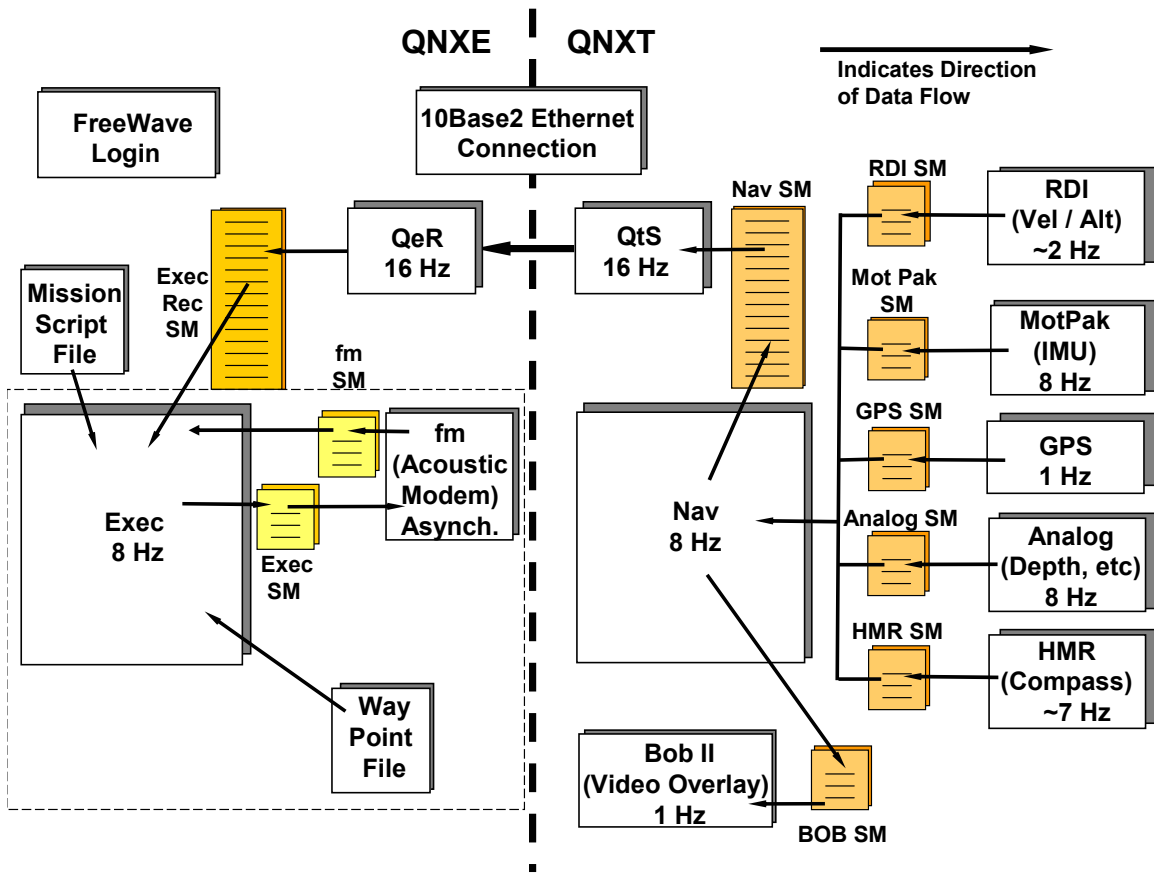

Figure 22. ARIES Baseline Computer Software Architecture, Showing Processors, Network Connections, Processes, Shared Memory (SM) Structures, and Mission Definition Files. Boxed Region in QNXE Was Later Modified for Rendezvous as shown in Fig. 24 (After: Marco, 2001)

speed, depth or altitude, time limit for arriving at the next waypoint, and how closely to approach the waypoint before activating the next waypoint. The details of the ARIES waypoint file are shown in Fig. 23.

1	2	3	4	5	6	7	8	9	10	11
596.66	1286.09	2.75	2.75	1	1.75	2.0	1	25.0	8.00	40.0
533.43	1326.44	2.75	2.75	0	1.75	2.0	1	25.0	8.00	150.0
471.02	1368.04	2.25	2.25	1	1.75	2.0	0	25.0	8.00	100.0
408.61	1409.64	2.25	2.25	1	1.75	2.0	0	25.0	8.00	100.0
330.40	1463.58	2.75	2.75	0	1.75	2.0	1	25.0	8.00	150.0
409.16	1410.47	2.75	2.75	0	1.75	2.0	1	25.0	8.00	200.0

Each row defines a single way point. Columns 1-11 contain:

Column	Description
1	Way point X position (meters).
2	Way point Y position (meters).
3	Left screw speed command (volts).
4	Right screw speed command (volts).
5	Control mode flag, 0 = Depth control, 1 = Altitude control.
6	Altitude command (meters, if applicable).
7	Depth command (meters, if applicable).
8	Perform GPS popup on this track, 1 = Yes, 0 = No.
9	Duration of GPS popup (sec).
10	Watch radius (meters)
11	Way point timeout – mission aborts if ARIES has not reached the watch radius of the waypoint after heading for this waypoint for this amount of time (sec)

Figure 23. Structure of ARIES Way Point File (After: Marco, 2001)

The normal method to log in to ARIES' computers is via 10Base2 ethernet connection to the QNXE/QNXN network. The operator uses network utilities such as telnet and ftp to control computer operations; retrieve, edit, and store computer files; compile the C code in which ARIES is programmed; and start and stop processes and missions. QNXE also provides two methods of communications with ARIES when it is physically disconnected from a computer network, as is the case during underway ARIES operations. A FreeWave radio modem connection via a serial port permits an operator to take control and issue commands to QNXE when the FreeWave antenna is above the surface of the water during an operation. Additionally, ARIES' acoustic modem is controlled by a process (fm) hosted by QNXE. The modem does not provide direct control of the QNXE processor, as does login over the FreeWave or 10Base2 Ethernet connection, but it does accept a limited set of commands defined in and recognized by the

fm and Exec processes. Such commands, if successfully parsed by the modem process, are written to modem shared memory where the Exec process reads and executes the command. Additionally, if the modem process successfully parses and passes on to the Exec process a pre-defined query for data, the processes obtain and write the requested data to the modem for transmission.

F. HARDWARE MODIFICATIONS TO ENABLE RENDEZVOUS

Because ARIES was designed to serve as a communications node, little hardware modification was necessary. The only change was installation of the electric current sensor which was used to determine the vehicle's power characteristics. After measuring the necessary power data, this sensor remained in place as a development tool for future ARIES modifications. It is not necessary for actual rendezvous operations as implemented here.

G. SUMMARY OF NECESSARY SOFTWARE MODIFICATIONS

The basic navigational nature of QNXT processes required no modification. However, because of the command and control nature of QNXE processes, extensive modification was required in QNXE software.

1. Dynamic, Autonomous Mission Planning Process

As is the case with most AUVs, an ARIES mission is written and loaded into the vehicle prior to starting the mission. At the start of the mission ARIES parses the mission script file, which normally directs it to read the contents of the way point file into memory. The mission then consists of ARIES driving to each way point in a pre-determined sequence and manner. This relatively static mission definition is unsuitable for the rendezvous operations in that it does not permit ARIES to respond to rendezvous requests. To respond to a rendezvous request, ARIES operations must change once execution has begun. Beginning with a "loiter phase", the operation must progress to a "closing phase" in response to a feasible rendezvous request. During the closing phase ARIES closes the position of the sensor or target vehicle. At the rendezvous point ARIES must transition to a "rendezvous phase", during which it remains in close proximity of the target vehicle and conducts rendezvous communications. Finally, upon completion of rendezvous communications, ARIES must return to its loiter phase. These transitions, which involve timing and positioning which cannot be known a priori, require

dynamic, autonomous, on-board planning of the new mission. To accomplish this a new rendezvous planning process, named RPlan, was written to run concurrently and interact with a version of the Exec process modified for rendezvous to allow activation of new missions during an ARIES rendezvous operation. This modified process is named RExec.

For baseline ARIES operations, involving the execution of a mission defined by a single waypoint file, the term “mission” refers to both the entirety of ARIES’ behavior during a single deployment as well as the contents of a single waypoint file. To avoid confusion in rendezvous ARIES terminology, where multiple “missions” may be executed during a single deployment, the term “mission” will refer to the contents of a single waypoint file. The term “operation” will refer to an ARIES deployment, during while several “missions” are expected to be executed.

2. Additional Layer of Control

The sequence of events involved in responding to a rendezvous request must be controlled by a higher level of logic than that of the base line ARIES or most other current AUVs. Whereas the typical AUV mission follows a sequence of waypoints or commands, rendezvous operations involve interpreting inter-vehicle communications, dynamic mission planning, error checking, multiple mission activation, and measures to provide robustness in the event of plausible problems. Management of such operations requires an additional layer of supervisory logic. In this implementation, a finite state machine was incorporated into the Exec process to monitor operation events and to shift ARIES mode of control of in response.

3. Mission Activation

Once written, the planned mission must be activated. In other words, its waypoints and other data must be read into Exec memory and the vehicle mission set to execute it. The baseline ARIES software performed this step once, at the beginning of its mission, with the mission consisting of proceeding to each way point in succession. Upon arriving at the final waypoint, the mission was terminated. For rendezvous, mission activation must take place mid-operation, whenever required by initiation or

completion of rendezvous. To accomplish this, Exec was modified to allow mission activation whenever required. Additionally, any of several way point files could be activated.

4. Queue Management

The asynchronous nature of the vehicle network required a queue in which to store incoming rendezvous requests. Additionally, typical queue management functions were necessary to perform such actions as testing for the presence of a request in the queue, clearing the top request from the queue once action is complete, or writing a new request to the bottom of the queue. Because queued rendezvous requests contained sensor vehicle navigation data, which could be updated by the sensor vehicle while the request remained queued, queue management in this implementation also need to distinguish between initial and subsequent rendezvous requests from the same sensor vehicle. In the former case, the request is written to the queue. In the latter, the initial request retains its position in the queue, with the navigation data contained in the request being overwritten by the updated data contained in the subsequent request.

5. Shared Memory

Shared memory is a method used by the QNX operating system to make data available between cooperating processes. Shared memory structures are initialized at boot-up, and may be accessed by multiple processes for reading or writing data. Before a process writes data to or reads data from a shared memory structure, it sets a semaphore to prevent all other processes from accessing shared memory until the operation is complete. On completion it clears the semaphore, allowing access to the next process attempting to read or write to shared memory. Shared memory was already used extensively in ARIES prior to modification for rendezvous. Implementation of the rendezvous behavior resulted in addition of new variables to existing structures, as well as addition of a new structure to accompany the new mission planning process.

6. Modem Upgrade

As the conduit for rendezvous command-and-control communications, the modem process required modification. Some modification involved adapting its vocabulary to recognize messages required by the rendezvous process. However, the process was also rewritten to allow ARIES to initiate modem communications, something

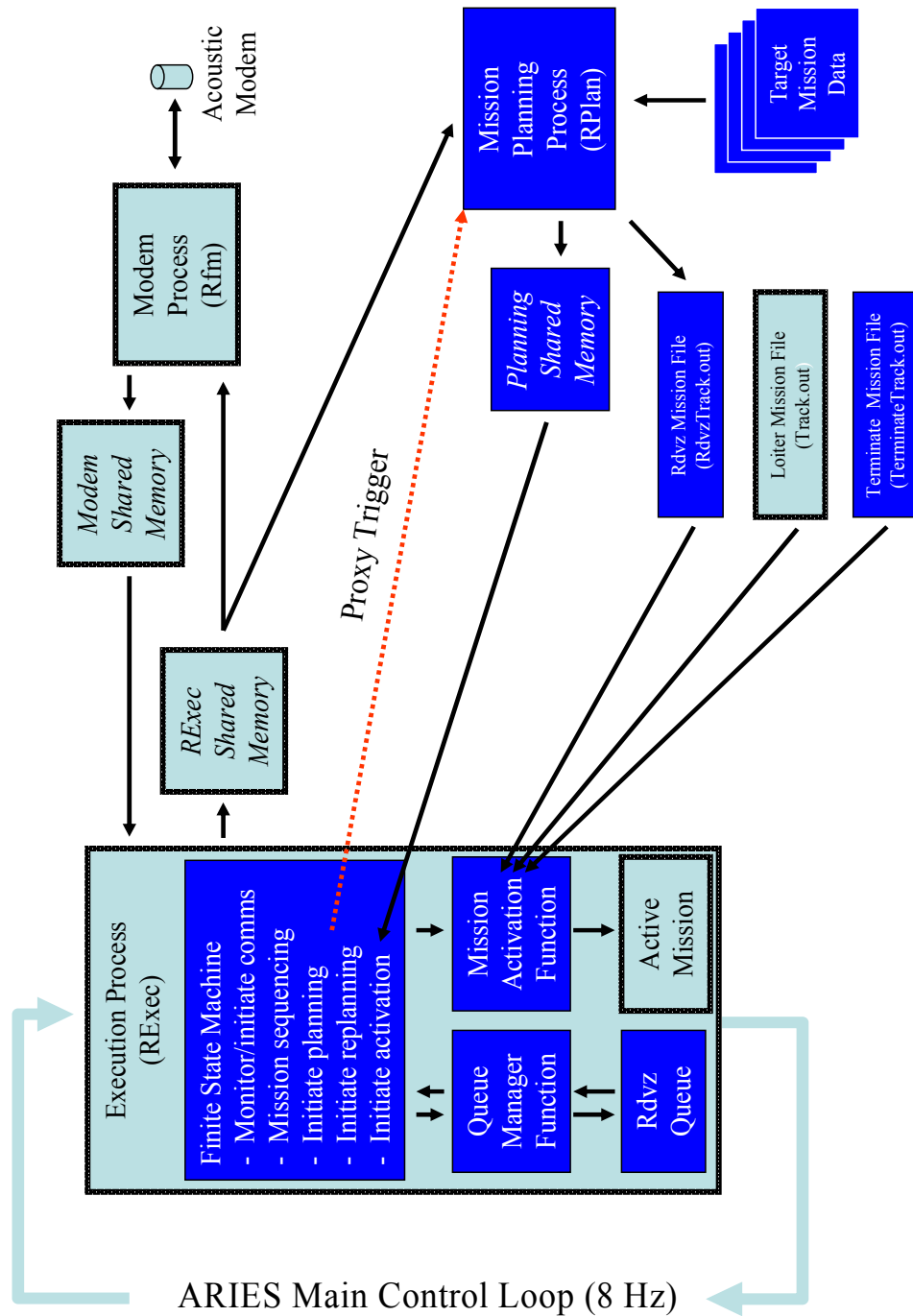

Figure 24. QNXE Software Modifications to Implement Rendezvous. Baseline ARIES Features are Light. Proxy Trigger and Dark Features were Added for Rendezvous

it had not done before. In the past, ARIES modem transmissions had been only in response to modem queries from another modem.

These software modifications are described in detail in the following sections. Figure 24 provides an overview of these modifications.

H. MISSION PLANNING PROCESS

1. Efficient Use of Computer Resources

Adding a new process to the QNXE processor and its existing processes, especially one which potentially would involve extensive mathematical computations as well as file input and output, led to an early decision make the process as computationally efficient as possible. Were the addition of the planning process to consume the remainder of QNXE's available resources, vital vehicle control functions in the Exec process such as autopilots could be disrupted. The following measures were taken to minimize the effect of the new planning process on existing QNXE processes:

- The planning process was written as a separate process, rather than a function to be called by Exec. Although an analysis of QNXE loading indicated that a substantial amount of unused resources were available for a planning process, the computational requirements of such a process would be unknown until it was written. Writing the planning process as a separate process allowed the possibility of running it as a lower priority than other QNXE processes, a feature of the QNX 4.23a operating system. As a lower priority process, the planning process would use whatever QNXE computer resources were available once other processes were serviced. This is permissible since the planning of the rendezvous mission is less time critical than vehicle control functions.

- The mission planning process was written such that it remained "receive blocked" until it was necessary to plan a mission. In this state, an inter-process control feature of the QNX 4.23a operating system, execution of the planning process is halted until it receives a signal from the RExec process. RExec sends this signal by triggering a QNX proxy message, which unblocks and starts the planning process.

- Wherever possible, planning calculations are performed prior to receipt of a rendezvous request to minimize calculations required during rendezvous request processing. Examples include calculating distances and courses between mission waypoints.

Testing of the completed mission planning process showed that QNXE was capable of hosting the planning and existing QNXE processes with all processes running at the same priority.

2. Data Required for Mission Planning

A variety of data is required to plan the rendezvous between the ARIES and target vehicle; including ARIES vehicle dynamics, ARIES state information, target vehicle state information, magnitude and direction of currents, and target vehicle mission parameters. This data can be divided into two categories: data onboard ARIES prior to the start of rendezvous mission planning, and data not onboard which must be included in the rendezvous request.

An ARIES vehicle dynamics model can be written into the planning process. Also, ARIES estimates its own state, and that information is onboard at all times. Additionally, assuming that ARIES has the capability to measure and estimate currents in the area of operations, so that data is onboard as well. It may be obtained as the difference between velocity over ground and velocity through the water, both of which are measured by the Acoustic Doppler Current Profiler (ADCP).

This leaves only target vehicle state information, some of which is assumed to be known a priori. As previously discussed, aspects of the target's mission that are not expected to change during the operation are loaded onto ARIES prior to the start of the operation. In this implementation this information was a sequential list of each target vehicle's waypoints. Three elements described each waypoint: X coordinate (meters), Y coordinate (meters), and vehicle forward speed through the water u while closing each waypoint (meters per second) . Describing the target vehicle's mission in this manner reduces the set of possible vehicle positions to a single segmented linear feature.

The only remaining data required to plan the rendezvous is the target vehicle's position along this path. This information generally will not be known to the server

vehicle unless the target vehicle is additionally constrained to maintain its progress along track in accordance with a pre-determined time table, an overly restrictive requirement which would increase the complexity of target vehicle design and not allow for unforeseen disturbances to target vehicle progress. A simple and accurate way to locate a vehicle constrained to move along a path is to describe its location as its progress along the path. Progress is expressed as the present path segment being completed and the fraction of that segment complete. For this scheme a progress value of 0 represents the vehicle located at the start of a segment and 1 represents the vehicle located at the finish. Target vehicle progress is included in the rendezvous request as a method of locating the target vehicle, the remaining information required to plan the rendezvous is available onboard ARIES.

3. Elements of a Rendezvous Request

The rendezvous request consists of the following elements. All are integer values that are transmitted via acoustic modem to ARIES.

a. Sender Identity

Because multiple target vehicles may be involved in an operation, this element identifies which vehicle sent the request.

b. Present Track Segment

This identifies which segment of its mission the target vehicle is presently completing, which is also the number of the way point at the end of the segment. As a result, way point “0” identifies the starting point of the target’s track and “1” is both the first segment of the target’s track and the waypoint at the end of the track.

c. Progress Along Present Track Segment

This is a three-digit integer describing fraction of present track segment complete, expressed in thousandths.

d. Time Stamp

Target vehicle position must be accompanied by the time the position was determined so that ARIES can correct the reported target vehicle position for time delays in transmitting and receiving the rendezvous request. Modem processing and sound propagation delays typically introduce several seconds of delay from transmission to reception and processing. This integer conveys the time for which rendezvous request

target vehicle state data was valid, in seconds since start of the operation. Note that this scheme requires synchronized clocks on ARIES and target vehicles.

e. Check Sum

Because an ARIES rendezvous mission is based on the information contained in a rendezvous request, because of the amount of data contained in the rendezvous request, and because of the likelihood that the rendezvous request may arrive garbled after long-range transmission between widely separated vehicles, a check sum is included in the rendezvous request. It is a simple sum of the four integers that precede it in the request. The check sum serves a second purpose in this demonstration of rendezvous behavior, where it is desirable to specify the optimization objective in the rendezvous request. To specify a time-optimal rendezvous the check sum is given a positive sign, while a negative check sum signals an energy-optimal rendezvous. For rendezvous operations outside of this demonstration, the particulars of the operation would determine whether time-optimal or energy-optimal rendezvous is desirable. In such cases this parameter would be set in ARIES prior to the operation, and would not be a necessary element of the rendezvous request.

4. Pre-Processing Target Data

The following calculations, which are performed on target data prior to the receipt of a rendezvous request, produce results that either will not change over the course of an operation or change slowly enough that they need not be repeated for each rendezvous request. This data is stored in a series of two-dimensional data arrays, with each row corresponding to a waypoint number and each column corresponding to a target vehicle number. Note that in the C programming language used in ARIES, the first element of an array is numbered “0”. Using this convention, the first waypoint of a mission is the “0th” way point, and the first row or column of a two-dimension array is the “0th” row or column.

a. Compute Segment Lengths

The Euclidean distance between each successive way point in a target’s mission is computed and stored in the array SegLen. Since the first segment of the target’s mission is the segment from waypoint 0 (first waypoint) to waypoint 1 (second way point), the first row of the SegLen array to contain computed segment lengths is row

1. Row 0 contains zeros, as there are only n-1 distances to compute between n way points. The first row of each of the following data arrays are also zeroes.

b. Compute Segment Courses Over Ground

The course over ground ψ_g for each segment is computed as:

$$\psi_g = \text{atan2}\left(\frac{\Delta Y}{\Delta X}\right) \quad (5.1)$$

or, the arctangent of the ratio of change in Y coordinate and X coordinate between two successive way points expressed as a value between $-\pi$ and π . These are stored in the array SegPsi

c. Compute Target Vehicle Speed Over Ground and Heading for Each Segment

In the absence of currents and other perturbations vehicle heading equals course over ground. However, rendezvous operations are assumed to take place in the presence of currents, and their effect is accounted for. Because the direction and magnitude of local currents vary slowly, their effects can be computed periodically on an appropriate time scale and considered constant between such updates. Doing so reduces the computations required in response to a rendezvous request. The target vehicle velocity over ground vector is the vector sum of velocity through the water and current velocity. Given the previous assumption that the target vehicle maintains its ground track, the known quantities of course over ground, current magnitude and direction, and speed through the water can be used to solve for vehicle heading and speed over ground. These quantities are stored in the two-dimensional arrays Psi and U_g, and are updated whenever magnitude and direction of currents are updated.

5. Planning Time-Optimal Rendezvous

The following is the sequence of events for a time-optimal rendezvous request, assuming that the received request is properly formatted and the planning process passes all checks.

a. Validating Rendezvous Request Format

Upon receipt by the acoustic modem, the header of any incoming message is compared against established message header formats to establish the type of message

received and to handle it accordingly. Once the incoming message is classified a rendezvous request message, the message is parsed into individual data elements which are written into corresponding modem shared memory variables. A flag in modem shared memory is also set to signal arrival of a recognized message type to the RExec process, which reads the message data from modem shared memory into the appropriate RExec process variables.

Data received in the RExec process is checked against its check sum and written into the RExec rendezvous queue. At the appropriate time, as determined by the finite state machine, the request is retrieved from the rendezvous queue and computations begin which will result in a complete rendezvous mission waypoint file.

b. Determining Future Target Vehicle Positions and Synchronizing Data

To plan the rendezvous the planning process must adjust target position reported in the rendezvous request for delays in receiving the request and must project target position into the future. The method of accomplishing this begins with determining the expected time of arrival at each waypoint, beginning with the last way point reached by the target vehicle. For target vehicle i on segment j , this is way point $j-1$. The time t that the target vehicle arrived at this previous way point is computed as:

$$t[j-1] = t_{stamp} - \frac{(Prog)(SegLen[j,i])}{U_g[j,i]} - t_{op} \quad (5.2)$$

Where t_{stamp} is the time stamp contained in the rendezvous request, Prog is the target's fractional progress down the present segment ($[j,i]$) expressed as a number between 0 and 1, and t_{op} is clock time of the operation at the time of computation, which was initialized at zero for all vehicles at the start of the operation. In general, $t[j-1]$ has a negative value. This calculation removes the effects of delays in transmitting and processing the rendezvous request, thereby synchronizing the target's state data to ARIES' data. Also note that times produced by this calculation define the time of computation as $t=0$, so that all times are conveniently referenced to the time of computation. The target arrival times at way point $[j]$ and subsequent way points are computed sequentially as:

$$\begin{aligned}
t[j] &= t[j-1] + \frac{Seglen[j,i]}{U_g[j,i]} \\
t[j+1] &= t[j] + \frac{Seglen[j+1,i]}{U_g[j+1,i]} \\
&\bullet \\
&\bullet \\
&\bullet
\end{aligned}
\tag{5.3}$$

Target future position and arrival time at each way point is now established. Using these discrete future positions and times as a basis, and knowing speed over ground for each segment, future target position can be determined for any future time, or target time of arrival can be determined for any future position along its track.

c. Locating the Time-Optimal Rendezvous Point

The next step in planning the time-optimal rendezvous is to identify the time-optimal rendezvous point, or, the earliest time that ARIES can rendezvous with the target vehicle. The method for finding this point is based on the concept of reachable states, as discussed in Ch. III. Locating this time-optimal rendezvous point proceeds by examining each future target vehicle way point and determining whether or not it lies within ARIES set of reachable states. Because ARIES dynamics envelope is assumed to always include those of the target vehicle, the problem timeline is divided into two periods. During an early period rendezvous is not feasible, usually because ARIES' maximum speed does not allow it to reach the target vehicle by that time. During a later period rendezvous is always feasible. The boundary between these two periods is the earliest feasible rendezvous time, and only one such boundary exists. It is located by sequentially evaluating each of the target vehicle's future waypoints and determining whether ARIES can reach that point at the time the target is due to arrive there, on the same course and speed as the target, i.e., by determining whether rendezvous is possible at that point. The earliest way point for which rendezvous is feasible lies at the end of the segment that contains the time optimal rendezvous point, for the beginning point of that segment was a non-feasible point and therefore these two points bound the time-optimal rendezvous point.

Rendezvous feasibility for a given point on the target vehicle's track consists of determining whether there is sufficient time for ARIES to transit to the point and match target vehicle course and speed, assuming ARIES transits at maximum speed and accounting for the time and distance required for ARIES to accelerate, turn as necessary, and decelerate to target speed.

Such calculations require models of ARIES acceleration and deceleration (surge) and turn dynamics. An easily implementable and sufficiently accurate surge dynamics model suitable for this application was a first order linearly-damped model of the form:

$$u(t) = u_i + (u_f - u_i)e^{-\lambda t} \quad (5.4)$$

where u_i and u_f are initial and final forward speeds, respectively. ARIES operational data showed the value of λ to be approximately 0.2, yielding a five second time constant. This yields a speed model which can be easily integrated to compute the vehicle path length L required for the speed change:

$$L(t) = u_f t - \frac{u_f - u_i}{\lambda} (1 - e^{-\lambda t}) \quad (5.5)$$

The exponential form of the above equation results in infinitely long path lengths since this representation for speed never exactly reaches steady state. To prevent this and to keep the result practical, the planning process considers the speed transient complete once ARIES speed is within 0.1 meters per second of its steady state value. The model's fidelity with an actual ARIES speed transient is shown in Fig. 25.

Similarly, a simple model of ARIES turn dynamics was necessary. The common empirically determined turn parameters for marine vehicles, advance and transfer, were used in this application and are shown in Fig. 26. Advance is the distance along the initial track that the vehicle travels during the turn, and transfer is the cross-track distance during the turn. These parameters describe the physical dimensions of a vehicle's turn, allowing the rendezvous planning process to model turns when optimizing ARIES' trajectory in a rendezvous mission.

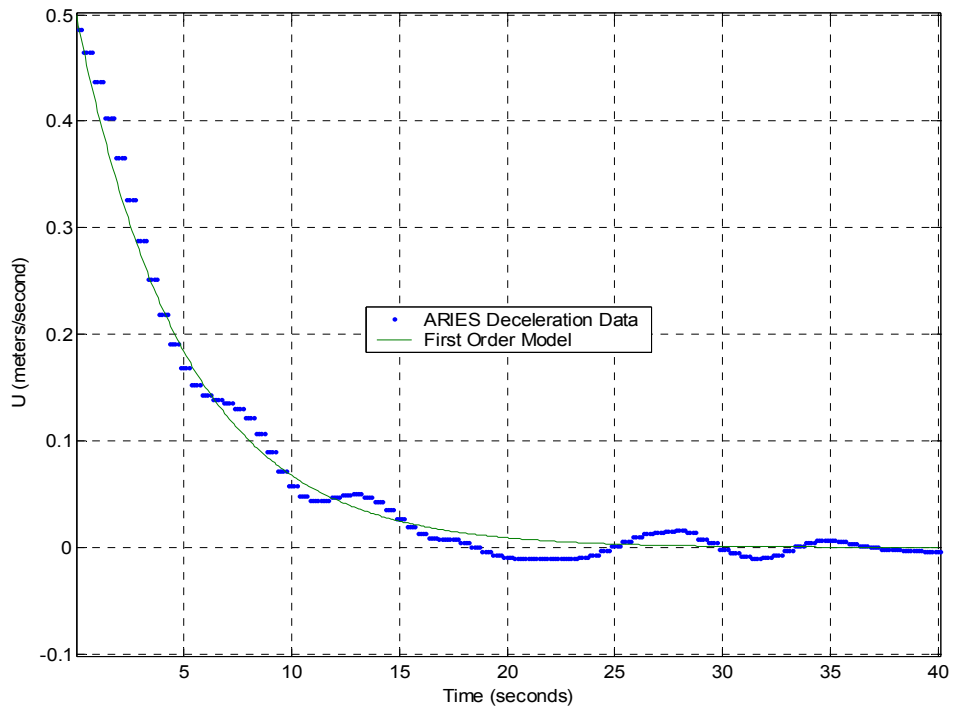

Figure 25. Comparison of ARIES Speed Transient and First-Order Model

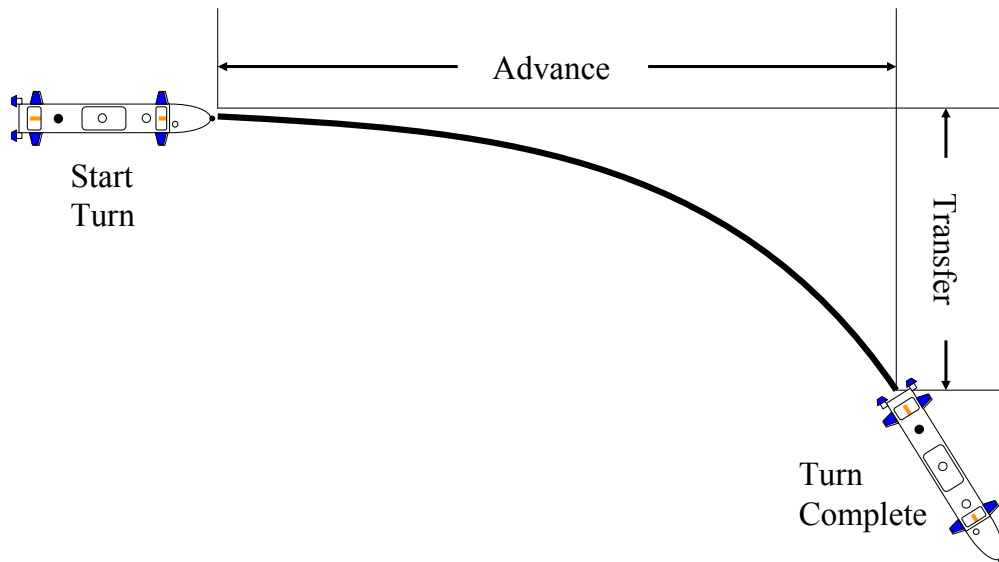

Figure 26. Advance and Transfer

During a series of experiments these parameters and total ARIES turn path length were measured, and models fitted to the data. Path length, when combined with ARIES speed, determines the time to complete the turn. A cubic polynomial was fit to each data set:

$$Advance = 3.178(\Delta\psi)^3 - 21.20(\Delta\psi)^2 + 36.83(\Delta\psi) \quad (5.6)$$

$$Transfer = -0.3837(\Delta\psi)^3 + 0.6694(\Delta\psi)^2 + 9.362(\Delta\psi) \quad (5.7)$$

$$PathLength = 3.345(\Delta\psi)^3 - 17.67(\Delta\psi)^2 + 37.01(\Delta\psi) \quad (5.8)$$

These functions are shown in Fig 27.

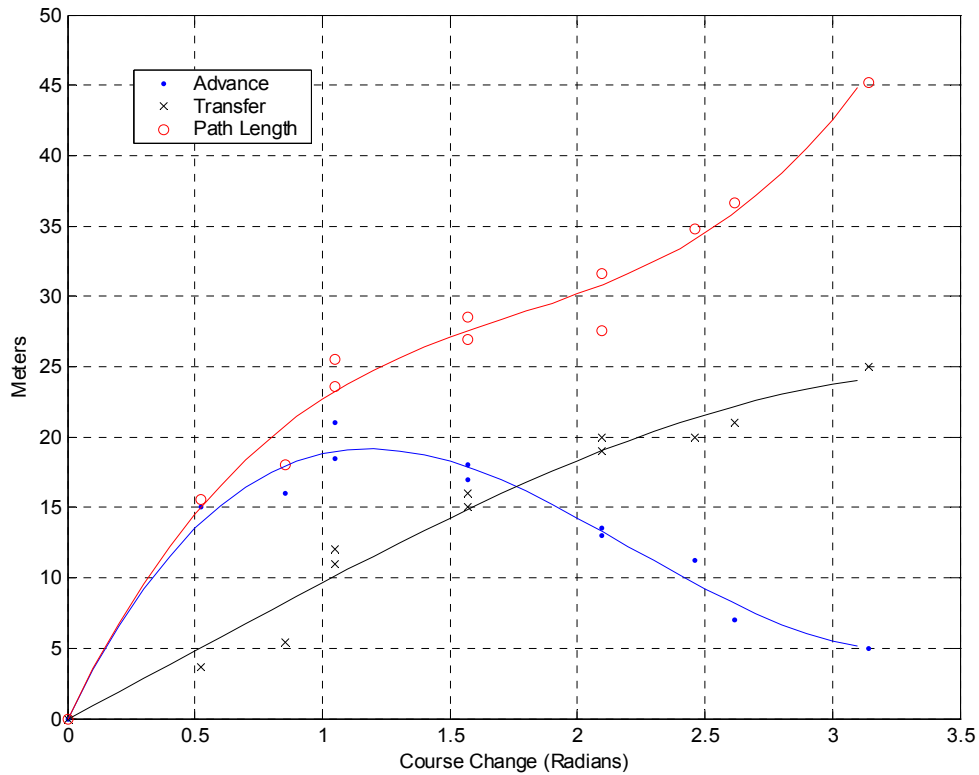

Figure 27. ARIES Advance, Transfer, and Path Length Versus Course Change

Using the above models, along with information on set and drift due to currents, the time and change in position required for each ARIES turn is computed by the planning process RPlan, as shown in Fig. 28.

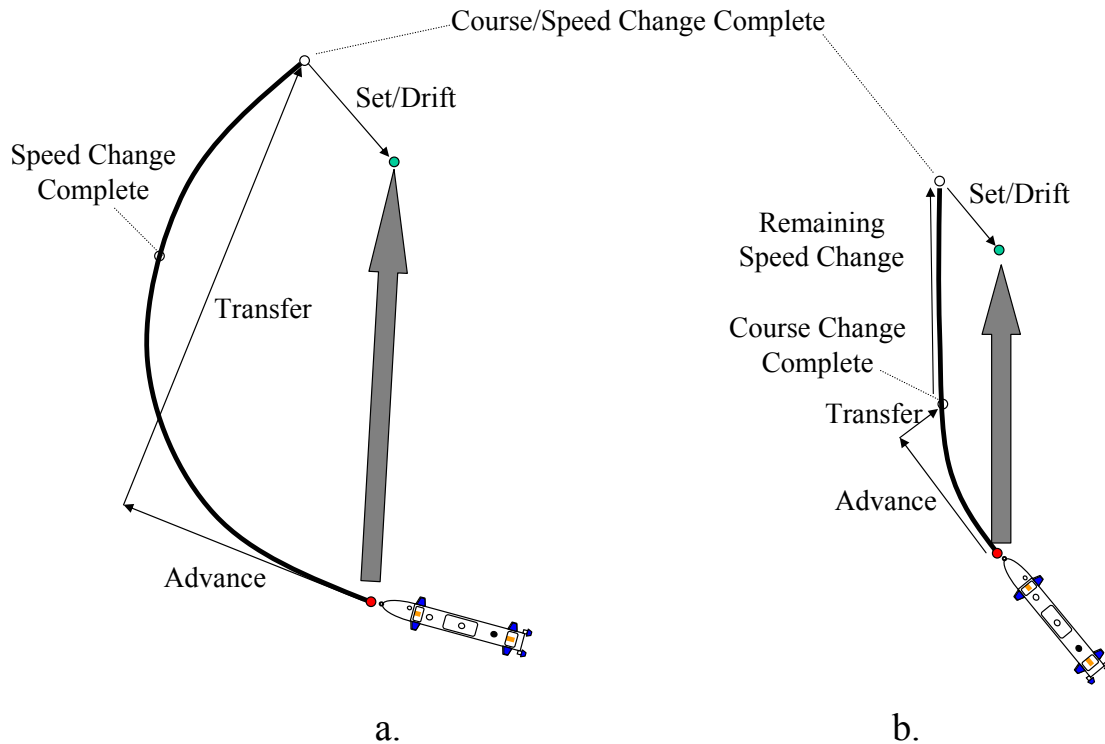

Figure 28. Calculating Effects of Course/Speed Changes With Currents. Large Course Change (a). Small Course Change With Speed Change Continuing After Course Change (b)

As discussed in previous chapters, these turns comprise the beginning and end of ARIES' closure trajectory for rendezvous. The remaining portion of the trajectory is a straight, steady-course, steady-speed segment between the two turns. It covers the period from the end of the initial course and speed change to the beginning of the final course and speed change. Hence, the ARIES trajectory is computed as three consecutive and separate segments tied together by boundary conditions on course, speed, and position at four key points. Starting at ARIES' initial position (X_i, Y_i) with initial course ψ_i and initial speed u_i ; point 1 (X_1, Y_1) is the end of the initial course / speed change maneuver and the start of the straight portion of the trajectory where ARIES course and speed are ψ_1 and u_1 respectively. Point 2 (X_2, Y_2) is the end of the straight portion of the trajectory and the start of the final course / speed change maneuver.

Note that $\psi_2 = \psi_1$ and $u_2 = u_1$. Point 3 (X_3, Y_3) is the rendezvous point. At this final point ARIES position, course, and speed match those of the target vehicle. The ARIES rendezvous trajectory is shown in Fig.29.

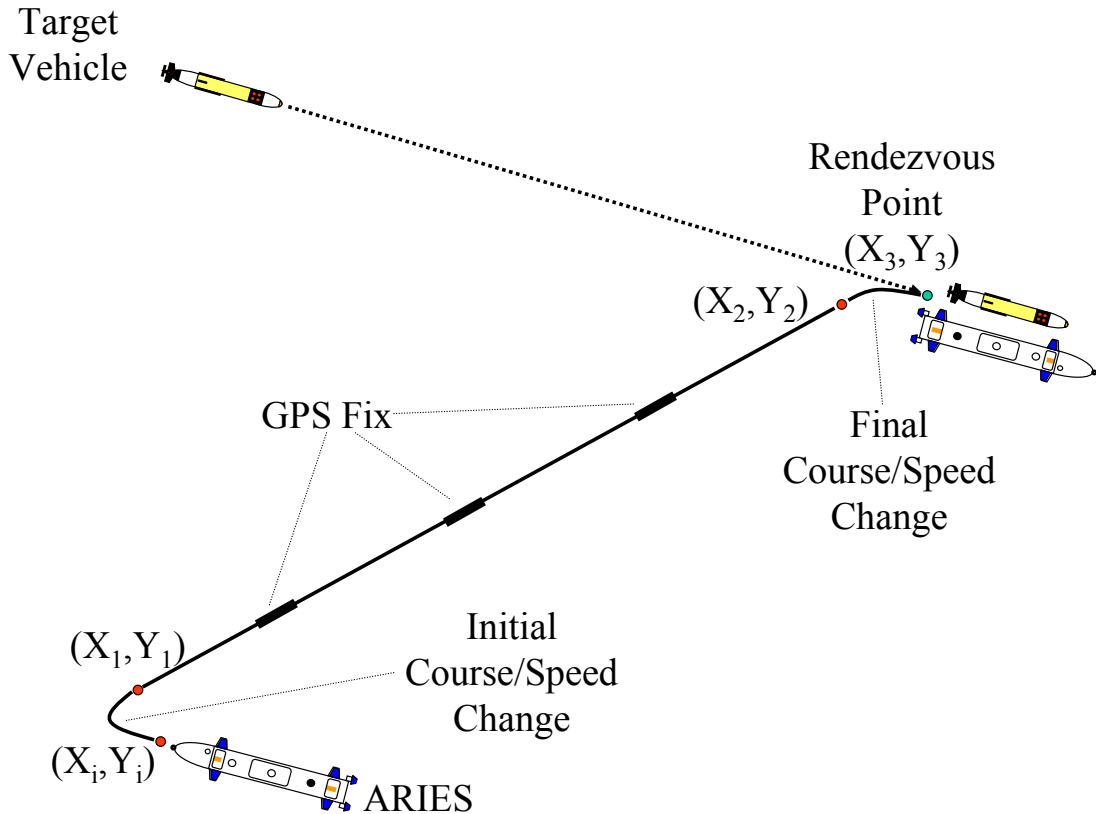

Figure 29. ARIES Rendezvous Trajectory

The process of planning ARIES' speed changes is fairly straightforward. The initial speed change takes ARIES from its initial speed, u_i , to the speed during the straight portion of closure, u_1 . Recall that for minimum time rendezvous u_1 is ARIES' maximum attainable speed.

For the sake of simplifying ARIES mission planning, both ARIES' final turn and final deceleration begin at point 2. This is a deviation from the results of the previous chapters, which in general did not require simultaneous final course and speed changes. This simplification avoids such complexities as planning a way point during the final turn to begin deceleration, without significantly altering the optimization of the

rendezvous trajectory. This does not occur during the initial turn since course and speed changes begin simultaneously at the beginning of this turn. The result of this simplified planning of the final turn is that ARIES either steadies on final course while decelerating, or reaches final speed while completing the turn, neither of which lead to significant sub-optimization.

The process of determining whether a target vehicle future waypoint is feasible begins by computing the effects of each course / speed change on ARIES trajectory. The advance, transfer, and path length are calculated for each turn. The path length required for the speed change is also calculated, using Eqn. 5.8 above. Whichever path length is longest determines the duration of the course / speed change transient. If the course change is significant, the turn path length dominates. Conversely, when minor course changes are made, the dominant consideration becomes the distance required to reach the steady state speed u_i . In the former case, (X_1, Y_1) are found by displacing (X_i, Y_i) the distance due to the effects advance and transfer, plus the distance due to currents over the time duration of the turn. For the latter case, (X_1, Y_1) are found by displacing (X_i, Y_i) the distance due to the effects advance and transfer, plus the additional distance along the final course ψ_1 required to complete the speed transient, plus the distance due to currents over the time duration of the turn. These are shown in Fig. 28. A similar approach is used for the final turn / speed change, except whereas the initial turn projected the effects forward from the initial known position, in the final turn the final position is known or assumed and these effects are projected backwards to find (X_2, Y_2) .

One complication to the above methodology is that the effects of neither turn can be calculated directly since each is a function of course change, a quantity that is unknown since it depends on the combined effects of both turns. For example, to find (X_1, Y_1) , advance and transfer data are applied to (X_i, Y_i) . However, advance and transfer depend on ARIES course between (X_1, Y_1) and (X_2, Y_2) , which depends on the unknowns (X_1, Y_1) . To overcome this complication, an iterative solution is used in the planning

process starting with an initial guess for the unknown course ψ_2 . This guess is the heading ψ_{2i} such that the current-corrected course over ground connects (X_i, Y_i) to (X_3, Y_3) , ARIES' initial and proposed final positions. Using this initial guess, initial values of (X_1, Y_1) and (X_2, Y_2) are obtained, which yield a refined value of ψ_1 . Iteration continues until neither X_2 nor Y_2 change by greater than 1 meter in the last iteration.

The above iterative algorithm fails to converge when ARIES is ahead of the target vehicle and within an ARIES turn diameter of the target vehicle's projected track, as illustrated in Fig. 30.

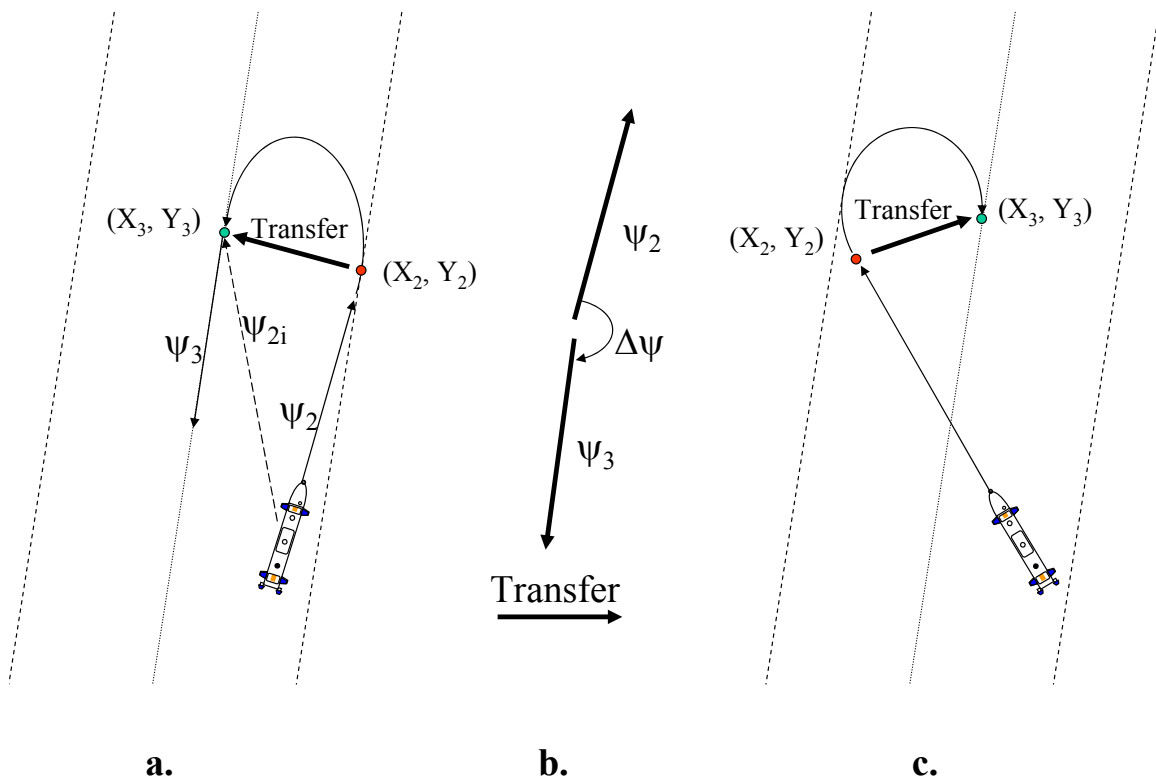

Figure 30. ARIES on Target Track Causes Planning Non-Convergence. Initial Computation of Transfer (a). First Refinement Iteration (b). Result of First Iteration(c)

In this case the planning process plans a final turn that is essentially a course reversal, but in excess of pi radians. In calculating the advance and transfer of any turn, the planning

process compares the initial and final headings and computes advance and transfer. The difficulty stems from the computation of transfer which, unlike advance, has sense. Advance has the same value whether a course change of given magnitude goes to the right or left of initial course. In computing transfer for a given course change, the direction of the course change must be noted so that the planning process applies transfer in the direction of the turn. For the case of ARIES near the target track, the final course change is approximately a full course reversal and is in excess of pi radians. In planning a turn, given an initial and final course, the two choices are to turn less than pi radians, in the direction of the next course, or to turn greater than pi radians, in the opposite direction, then to steady on the new course. The former is normally desirable, and is the method used in the planning process. On the initial computation of transfer for the final turn, a comparison of ψ_{2_i} and ψ_3 yields a value of transfer with the correct sense, as shown in Fig. 30(a). However, on the first iteration to refine the position of (X_2, Y_2) , ψ_3 is compared with the just-determined ψ_2 , which is based on the initial value of transfer. As shown in Fig. 30(b), the comparison of ψ_2 with ψ_3 yields a reversal of the sense for transfer, due the shortest turn between these two courses. Applying this value of transfer to (X_3, Y_3) in the backwards direction to locate (X_2, Y_2) shifts this point to the opposite side of the target's track. This results in another final turn in excess of pi radians, and in the course of planning this turn the opposite effect occurs, switching (X_2, Y_2) back to the original side of target track and never converging. To prevent non-convergence, whenever ARIES initial position is within 30 meters of target track the iterative process of locating (X_1, Y_1) and (X_2, Y_2) stops after one iteration. This single iteration first plans initial and final course changes based on target course and the course between the known locations (X_i, Y_i) and (X_3, Y_3) . The result is a loss of a few meters in accuracy, which may be reduced during subsequent replanning of the rendezvous mission.

If ARIES total transit time exceeds the time at which the target vehicle is due at this waypoint, the target's state at this time is not contained in ARIES set of reachable states, and rendezvous is not feasible. In this case the time-optimal rendezvous point occurs later, further down the target vehicle's track. Conversely, if the calculated

ARIES transit time is less than the time that the target vehicle requires to reach the way point, rendezvous is feasible at this point, albeit suboptimally as ARIES can feasibly arrive before the target. In this case, the time optimal rendezvous occurs at an earlier time and location along the target's track.

Having determined the time required to complete both course / speed changes and the endpoints of the straight portion of the trajectory, t_{1-2} , the available ARIES transit time between (X_2, Y_2) and (X_3, Y_3) is computed by subtracting the time required by both ARIES course/speed changes from the time that the target reaches the way point. The final step in determining rendezvous feasibility is to compare R_{1-2} , the distance between (X_1, Y_1) and (X_2, Y_2) , to R_A , the maximum distance ARIES could travel in along ψ_1 from (X_1, Y_1) and (X_2, Y_2) in t_{1-2} while correcting for prevailing currents. In the time optimal case,

$$R_A = R_{1-2} \quad (5.9)$$

as ARIES reaches the rendezvous point at the earliest possible moment. Locating the time-optimal rendezvous point therefore consists of finding the zero of

$$R_A - R_{1-2} \quad (5.10)$$

The zero is located iteratively using a secant-method algorithm (Betts, 2001).

d. Locating Remaining ARIES Way Points

The process of locating the time-optimal rendezvous point (X_3, Y_3) , the first way point found for the ARIES rendezvous mission, also locates the way point for beginning the final course / speed change (X_2, Y_2) as an intermediate result. The remaining rendezvous mission way points are added prior to (X_2, Y_2) as GPS fix way points, or after (X_3, Y_3) to guide ARIES along the target vehicle's track. In this implementation the first three target way points after (X_3, Y_3) were used in ARIES rendezvous mission to provide a sufficiently long rendezvous communication period. The number of GPS way points included prior to rendezvous is a function of R_{1-2} , which constitutes the majority of ARIES pre-rendezvous travel. GPS waypoint planning

consists of dividing the straight track between (X_1, Y_1) and (X_2, Y_2) into 200 meter long segments, starting at (X_2, Y_2) and stepping backwards towards X_1, Y_1 . ARIES surfaces for a GPS fix once in each 200 meter segment. A GPS fix is also planned in the segment between the earliest 200 meter segment and (X_1, Y_1) if that segment is at least 100 meters long, which provides sufficient time for the surfacing maneuver and course correction following the fix.

e. Planning Speeds

As shown in Fig. 23, each ARIES mission waypoint is specified by 11 parameters. Having determined the values in the first two columns for each waypoint in the time optimal rendezvous mission, X and Y coordinates, the remaining are then assigned. The next two columns contain N_{rs} and N_{ls} , the speed commands to the right and left thrusters respectively, which determine ARIES forward speed through the water u . Since the relationship between propeller speed and forward speed for vehicles such as ARIES is typically linear, experimental ARIES data was used to establish a linear relationship between thruster commands and commanded speed u_{com} :

$$N_{ls}, N_{rs} = 2.132u_{com} \quad (5.11)$$

Identical commands are sent to both thrusters. Experimentation with ARIES showed that its maximum speed is approximately 1.5 meters per second, so for time-optimal rendezvous waypoints up to and including (X_2, Y_2) speed corresponding to 1.5 meters per second is commanded. This results in ARIES using maximum speed from the start of the rendezvous mission until it reaches (X_2, Y_2) , the point at which it begins its deceleration to match target speed. For way points after (X_2, Y_2) , the speed command is the same as the target's speed.

f. Setting Way Point Timeouts

ARIES is programmed to abort its mission if it does reach its way point in a specified time period. This provides for mission termination in the event of a vehicle control or navigation failure. This feature, controlled by the parameter in the final column of the way point file, was left unmodified for this implementation, so it was

necessary to assign appropriate values to this parameter. Values of approximately 150% of expected time to reach each waypoint were assigned to each, a rule validated by previous ARIES research.

g. Planning GPS Fixes

As discussed above, GPS fixes may be planned prior to the rendezvous point. For each segment containing a GPS fix, the value in column 8 is set to “1” and the value in column 9 is set to 30, to allow a 30 second period in which to surface and obtain the fix.

h. Setting Watch Radii

This parameter determines when ARIES is considered to have reached the way point. When ARIES approaches the way point within this distance, or crosses a line perpendicular to the track connecting the current and previous way points and tangent to the watch radius circle, the next way point is activated and ARIES begins driving towards it. A typical value for this parameter is 10 meters, the value which is set for most way points and the value assumed to be used by the target vehicle. The exceptions are (X_2, Y_2) and (X_3, Y_3) , which define the entry into and exit from the final turn. In order to accurately control ARIES trajectory during the final turn into the rendezvous, these watch radii are set to 1 meter.

i. Setting Depths and Altitudes

These parameters are set in columns 5-7 of the way point file. Depth mode is selected in column 5 to maintain ARIES at a constant depth, which is set to 3 meters in column 6. Since altitude mode is not set in column 5, column 7 represents unused data for normal depth-mode ARIES missions. For this implementation this column is used to indicate whether ARIES is expected to be rendezvoused with the target at this time, an indication that triggers other ARIES actions. Therefore, for all waypoints after (X_2, Y_2) this value is set to “7” to indicate rendezvous should be in progress.

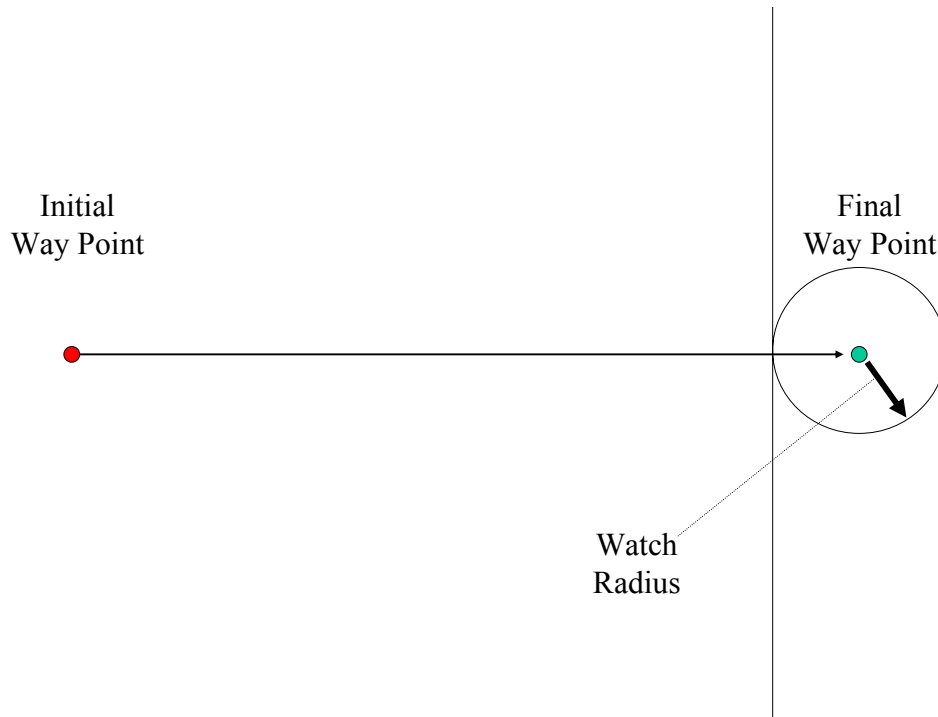

Figure 31. Watch Radius

j. Writing the Mission to File

Once all rendezvous mission parameters have been assigned, the mission is checked for feasibility by verifying that each planned way point lies within the previously determined area of operations. Once checked, the mission is written to the way point file “RdvzTrack.out”, which is opened and executed by the RExec process.

6. Planning Energy-Optimal Rendezvous

The steps to planning an energy-optimal rendezvous are a superset of the steps for planning a time-optimal rendezvous. All the time-optimal planning steps – finding the time optimal rendezvous point, planning GPS fixes, setting speeds and other parameters, checking for feasibility, and writing the mission to file – are taken; however energy-optimal rendezvous planning involves additional complexity requiring additional intermediate steps.

a. Bounding the Energy-Optimal Rendezvous Point

Whereas the time optimal rendezvous point was uniquely defined as the position of the target vehicle at the earliest time for which the target state was included in

ARIES set of reachable states, the energy optimal rendezvous point is one of many possible reachable states. This is so because, by its nature, the energy optimal rendezvous involves closing the target at a slower, more energy-efficient speed. As was the case with time-optimal rendezvous, the target state is not included in the set of reachable states prior to the time-optimal rendezvous point, therefore the time-optimal rendezvous point sets the earliest possible bound for the energy-optimal rendezvous. This provides the planning process a wide range of possible rendezvous points, all of which lie after the time optimal rendezvous point.

The energy optimal rendezvous point lies somewhere in a single region that is bounded by this point and another similar point. Practical limits on slow-speed vehicle controllability define this latest-possible bound on energy optimal rendezvous when it occurs prior to end of target mission. Because vehicles such as ARIES use control surfaces to generate forces to control attitude, course, and depth; and because these forces are proportional to the square of forward speed, there exists a practical minimum speed u_{min} below which the forces generated by its control surfaces can no longer overcome buoyant forces, surface suction forces, or other disturbances. This minimum speed sets a lower bound on propulsion power, and results in an upper bound on time for energy-optimal rendezvous. Minimum ARIES speed sets a lower bound on minimum energy used for rendezvous:

$$E = \int_{t=0}^{t_3} A + Bu_{min}^3 dt = t_3 (A + Bu_{min}^3) \quad (5.12)$$

where t_3 is the time of rendezvous, A is vehicle hotel load in watts, and B is the propulsion power coefficient in watt-second³/meter³. Since the term in parenthesis is constant, the minimum energy to rendezvous is a linear function of time. As a result, if there exist multiple opportunities to rendezvous with ARIES closing the target at u_{min} , all opportunities after the first opportunity require more energy. As a result, the earliest rendezvous time for ARIES using its minimum speed throughout the closure to rendezvous sets a latest possible time for minimum-energy rendezvous. The minimum energy rendezvous point lies between the first time that the target's state is included in

ARIES set of reachable states at maximum ARIES speed and the first time it is included at ARIES minimum speed, as shown in Fig. 32.

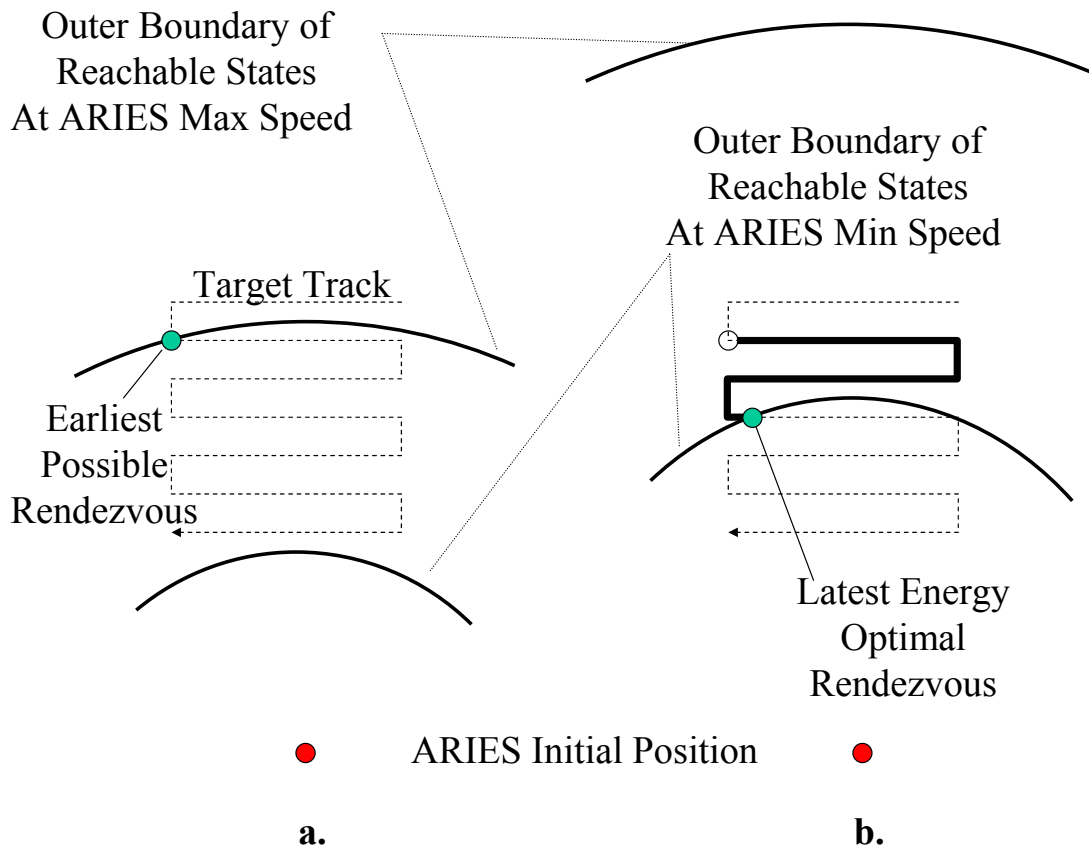

Figure 32. Earliest Possible Energy-Optimal Rendezvous (a). Latest Possible Energy Optimal Rendezvous (b)

There are two exceptions to the above result. First, if the target vehicle's mission terminates prior to the time that ARIES could reach it at minimum speed then obviously the latest possible rendezvous time is the end of the target's mission. Second, in a similar situation, if the target continuously opens ARIES position at a speed higher than u_{min} , ARIES cannot reach the target before the end of the target mission. However, this is unlikely since target vehicles are assumed to remain in within a bounded geographical area, meaning their overall speed away from ARIES is likely to be low.

Bounding the times of possible minimum energy rendezvous conserves computational resources required for the energy optimal rendezvous by limiting the size of the space to be search for a solution.

b. Locating the Energy-Optimal Rendezvous Point

This process uses the same subroutines used to find the time-optimal rendezvous point. First, the time-optimal rendezvous point is located on the target vehicle's track, marking the earliest possible time for energy optimal rendezvous.

After this step the sequence of steps for planning the energy-optimal rendezvous trajectory departs from the time-optimal sequence. The next step in the energy-optimal planning process is to identify the latest possible energy-optimal rendezvous. The same algorithm is used, except whereas the earliest time was identified by setting ARIES speed to its maximum value of 1.5 meters per second, the search for the latest time is conducted using ARIES minimum speed of 1.0 meters per second.

Having defined the portion of the target's track containing the minimum energy rendezvous point, the track is sampled to determine the energy required to rendezvous at each sample point. For each sample point the speed to reach that point is computed as trajectory path length between ARIES and the point, divided by the time the target vehicle will be at the point. The energy required by the rendezvous trajectory to that point is then calculated for each point as

$$E = (A + Bu^3)t \quad (5.13)$$

and the minimum energy rendezvous point is identified as the point having the lowest value of E.

Once the minimum energy point is identified, the planning process plans the trajectory from ARIES position to the rendezvous point. The process is similar to that of the time-optimal case, which used a constant speed to iteratively locate the rendezvous point. However, in this case the rendezvous point is held constant while the course and speed changes necessary to reach the point are solved iteratively.

Having determined the energy-optimal rendezvous point, the remainder of the planning process is identical to that for the time-optimal rendezvous. Additional way points are added to the mission and waypoint parameters are set for each waypoint, only difference being that ARIES speed command prior to the rendezvous point is a lower, energy-efficient speed rather than maximum attainable speed. The mission is checked for feasibility, and written to the way point file RdvzTrack.out.

I. STATE MACHINE

Having provided ARIES the capability to autonomously reconfigure its operations by planning new missions in response to requests by other vehicles, it was necessary to add another layer of logic above that of baseline ARIES. The form selected was a finite state machine, illustrated in Fig. 33. The finite state machine is a representation of a process consisting of states and transitions (Hatley, Hruschka, and Pirbhai, 2000). In the ARIES state machine, each state is a stage of the rendezvous process. Associated with each state are actions taken by the vehicle. Transitions between states occur in response to events sensed by the vehicle. Each state is responsive to a specific set of events, with no action taken for events not associated with that state. Each state also has an associated set of transitions it may take to the next state. The finite state machine provides a clear framework upon which to define the logic of the rendezvous process, and provides a high level of control over the process. This is essential since it is now necessary to automate a multi-state ARIES mission, containing both previous ARIES processes as well as new and modified processes.

The state machine comprises a new, third layer of control above two layers that existed in the vehicle prior to this work. The three-layer approach is common in robotics software architecture, with the Rational Behavior Model (RBM) (Kwak, McGee, and Bihari, 1992) representing one implementation. In ARIES the lowest layer, corresponding the execution level of the RBM, contains the autopilots that control the vehicle's fins and rudders to keep the vehicle on prescribed course and depth, which reside in the process RExec. The middle layer, corresponding the RBM tactical level, contains the mission control functions, also resident in the RExec process. This logic interprets the mission script and waypoint files and sequences the vehicle through the mission defined in these files. Mission parameters contained in these files are provided to the execution level for action. The state machine, representing the strategic level of the RBM, sequences ARIES through multiple missions during its operation and performs

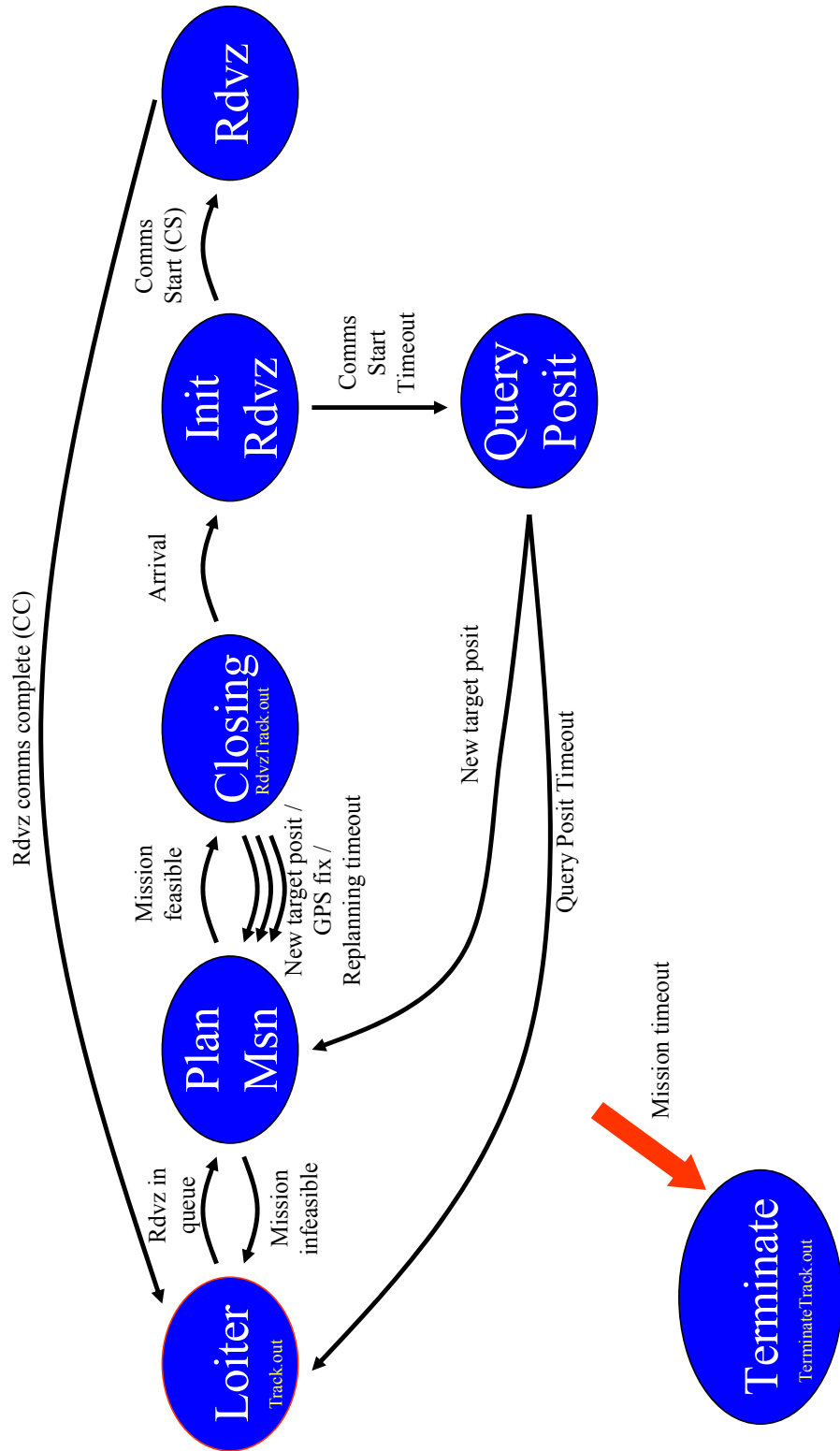

Figure 33. ARIES Finite State Machine, Showing States and Transitions

supporting functions such as initiation and interpretation of communications and initiation of mission planning. This hierarchy is shown in Fig. 34.

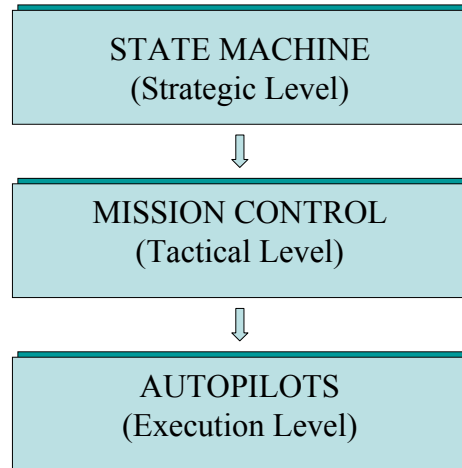

Figure 34. ARIES Three-Layer Rendezvous Software Architecture

The state machine is implemented in ARIES RExec code by defining the variable “State” and changing its value whenever criteria are met for transition to the next state. There are seven possible states, and with transition criteria and actions defined for each. At each 125 millisecond cycle of RExec’s main control loop the transition criteria are examined. If satisfied, the state transition occurs by the next cycle.

1. Loiter

LOITER is ARIES’s initial state upon starting the RExec process.

a. Actions

While in LOITER, ARIES follows the way point file “Track.out”. This behavior is the same as baseline ARIES behavior, except for mission timeout, providing backward compatibility with baseline ARIES missions. To run a baseline ARIES mission under rendezvous software architecture, one need only define the mission in the mission script file script.d and way point file Track.out and run the mission under RExec without issuing any rendezvous requests to ARIES.

For rendezvous missions the way point file Track.out defines ARIES loiter location, courses and speeds. In general ARIES loiters at low, energy-efficient speeds, fixing its position periodically with GPS.

Any transition to LOITER reactivates the way point file Track.out.

b. Transitions

While in LOITER, ARIES checks the status of the rendezvous request queue each 125 millisecond cycle of the RExec control loop. ARIES remains in the LOITER state as long as the queue remains empty, transitioning to the mission planning PLAN MSN state as soon as a request appears in the queue.

There are three transitions into the LOITER state. If ARIES is in the RENDEZVOUS state, the LOITER state is entered upon completion of the rendezvous. If, while attempting to initiate rendezvous communications, ARIES cannot contact the target vehicle, it returns to the LOITER state. If the rendezvous planning process produces an infeasible rendezvous mission, the state returns to LOITER. Note that whenever rendezvous requests exist in the queue prior to ARIES entering the LOITER state, ARIES immediately transitions to the PLAN MSN state.

2. Plan Mission

a. Actions

Upon entering the PLAN MSN state, RExec writes the parameters contained in the next rendezvous request in the queue to RExec shared memory. This makes the request available to the rendezvous mission planning process RPlan. RExec then triggers RPlan's proxy, which frees the RPlan process from its normal "receive blocked" execution-suspended condition and begins the mission planning process. On subsequent control loop cycles RExec monitors the status of the planning process, which is indicated by values written to RPlan shared memory by the RPlan process, and take actions based on the outcome of the planning process.

b. Transitions

There are five transitions into the PLAN MSN state. The previously discussed transition from the LOITER state occurs for initial planning of a mission in the rendezvous request queue. The remaining four are due to replanning a rendezvous mission in progress in order to improve navigational accuracy. If a subsequent

rendezvous request is received from the same target vehicle that ARIES is closing for rendezvous, but before the rendezvous commences, the updated target position data contained in the request is used to replan the mission by reentering the PLAN MSN state. Similarly, if ARIES is unable to establish rendezvous communications with the target vehicle after arrival at the rendezvous point, it queries the target for its position. The position contained in the response to the query is used to replan the mission. Whereas these allow replanning to correct target vehicle position, there are two instances when the rendezvous mission is replanned to correct for ARIES position. Whenever ARIES obtains a new GPS fix, subject to a restriction that no GPS fix has been obtained within a specified time period, replanning occurs. Finally, replanning occurs if ARIES fails to obtain a scheduled GPS fix. Although in such cases no new position data is obtained to improve the accuracy of ARIES' position, disturbances such as currents and speed variations will perturb ARIES as it drives down its track towards rendezvous. Periodic replanning allows ARIES to adjust its rendezvous plan to ensure it meets the target at the rendezvous point.

There are two transitions out of the PLAN MSN state. As discussed above, when the rendezvous planning process produces an infeasible mission, state transitions to LOITER. In addition, the rendezvous request is cleared from the queue so that the next request may be acted upon. On the other hand, if the mission planning process produces a feasible mission, RExec opens the rendezvous mission way point file RdvzTrack.out, reads the contents into memory to begin executing the rendezvous mission, and ARIES enters the CLOSING state.

3. Closing

ARIES is in the CLOSING state from the time it begins executing a rendezvous mission until it reaches the rendezvous point, with the exception of transitions to the PLAN MSN state for replanning.

a. Actions

While closing the rendezvous point ARIES monitors replanning criteria.

b. Transitions

The CLOSING state is entered upon successful completion of mission planning. Transition out of the closing state occurs for replanning or arrival at the rendezvous point.

Replanning in response to a subsequent rendezvous request from the current target vehicle occurs when the queue management process determines that this has occurred.

Replanning in response to a good GPS fix begins after an unbroken ten second period of receiving three or more GPS satellites, if no GPS fix has been obtained in the previous 60 seconds. The 60 second period ensures that once such a GPS fix period exceeds 10 seconds, the planning process is not repeatedly triggered each RExec cycle. The ten second/three satellite criterion is based on previous ARIES navigation system performance. Note that failure to meet this fix criterion does result in rejection of the GPS fix data. Although replanning does not occur if the criteria are not met, ARIES navigation is still updated by the GPS data and the correction of ARIES position still occurs in the navigation filter. This updated navigation data will then be applied to the next mission replanning event.

If a GPS fix satisfying the above criteria is not obtained, a 30 second timer is started. If no GPS fix is obtained in this period, replanning commences.

Upon arrival at (X_2, Y_2) , the start of the final course/speed change, ARIES transitions from the closing state to the initiate rendezvous or INIT RDVZ state. Arrival at this point is signaled by the activation of the way point (X_3, Y_3) . It, and all subsequent way points in the rendezvous mission, contain the value “7” for the 6th way point parameter. This is the state machine transition signal.

4. Initiate Rendezvous

a. Actions

Upon entry into this state, ARIES attempts to initiate rendezvous communications with the target vehicle which should be nearby.

b. Transitions

The INIT RDVZ state is entered upon activation of the rendezvous point as the next ARIES way point.

The state is exited either when rendezvous communications are established with the target vehicle, or after no rendezvous communications occur after 60 seconds.

5. Rendezvous

a. Actions

In the rendezvous or RDVZ state, ARIES conducts rendezvous communications while it continues to follow the rendezvous mission.

b. Transitions

The state is entered at the start of rendezvous communications, and is exited at their completion.

6. Query Position

Should ARIES be unable to establish rendezvous communications within 60 seconds of entering the INIT RDVZ state, it enters the query position or QUERY POSIT state and attempts to locate the target vehicle, the assumption being that it is not in the immediate vicinity, outside the limited range of the high-bandwidth rendezvous communications device.

a. Actions

ARIES transmits a query to the target vehicle, asking it to send an updated rendezvous request with which ARIES may plan a new rendezvous mission.

b. Transitions

The state is entered at the expiration of a 60 second timer from the INIT RDVZ state. It is exited if no response to the query is received. In this case, ARIES enters the LOITER state. If a response is received, the state becomes PLAN MSN.

7. Terminate

When the operation involving ARIES and its network of sensor vehicles reaches its scheduled completion, ARIES' logic must terminate this phase of the operation and activate the final phase: returning for recovery. To do so, ARIES enters the

TERMINATE state. This state is unique in that it can be entered from any state, which provides a “fail-safe” feature to break ARIES out of whatever phase of operations it may be involved in.

a. Actions

Upon entry into the TERMINATE state, ARIES activates the way point file TerminateTrack.out, which brings ARIES to its recovery point. Periodic GPS fixes are obtained enroute to maintain accurate navigation.

b. Transitions

The state is entered upon expiration of the mission timer. There are no transitions out of the state.

8. Receipt of Rendezvous Requests and Other Modem Messages

The asynchronous operations of the vehicle network result in rendezvous request transmission at any time. The state machine ensures that ARIES acts on requests only when appropriate, however incoming requests must be properly handled at any stage of the operation. To ensure this occurs, the state machine portion of the RExec process takes the same action on incoming requests regardless of state. Within the RExec 8 Hz control loop, immediately before the state machine block of code, the RExec process reads modem shared memory to check for arrival of any new modem message. Arrival of a new message is signaled by the modem process Rfm setting one of its shared memory variables, an integer that serves as a flag, to TRUE. If set, the data contained in the message is read from modem shared memory into RExec.

If the message is a rendezvous request or pertains to rendezvous communications, the value of the RExec variable “SMEvent” , or state machine modem event, is set to signal this event. It can signal four different events: receipt of a rendezvous request requiring immediate planning, receipt of a rendezvous request to be queued for later planning, start of rendezvous communications, and completion of rendezvous communications. The value of SMEvent is an input to the state machine to potentially trigger a state transition.

If the modem message is a rendezvous request, the checksum is validated and the request written to the queue.

Any abort command received by the modem process triggers a block of code which immediately brings ARIES to the surface and shuts it down, bypassing the state machine.

If the message is a position query, it is processed by the modem Rfm process without involving the RExec process.

9. Initiating Modem Transmissions

The state machine periodically generates outgoing modem transmissions. Because ARIES carries only its Benthos modem, with no high data-rate rendezvous communications equipment, this modem serves both command and control and simulated data functions. As a result, all communications go through this one modem.

As discussed previously, ARIES transmits to attempt to begin rendezvous communications, and transmits to query for target position if rendezvous communications do not start within the expected time. In an actual operation, as opposed to this demonstration, the former would be transmitted as short-range data communications and the latter as long-range command and control communications.

For the purposes of this development and demonstration additional modem status messages are initiated by the state machine to supplement the above transmissions to better track vehicle status, although they would not be used in an operational setting. These transmissions are shown in Table 1.

J. MISSION ACTIVATION

The baseline ARIES execution process Exec opened one way point file at the start of its mission, loading data into memory and performing necessary calculations only once. Calculations include such parameters as courses and lengths of each segment, time out for the first way point based on ARIES initial position, and whether the first way point is too close and should be skipped. The RExec process required the flexibility to do this mid-operation, whenever a new mission is activated by the state machine. To this end, these functions were removed from RExec and rewritten as a distinct subroutine of RExec which could be called whenever necessary, taking the way point file name and ARIES position as input arguments.

MODEM TRANSMISSION	TRANSLATION
<i>“CLOSING”</i>	Successful completion of the mission planning or replanning.
<i>“INFEAS RDVZ, LOITER”</i>	Mission planning resulted in an infeasible rendezvous mission plan.
<i>“QUERY POSIT TIMEOUT”</i>	Rendezvous attempt abandoned after no rendezvous communications established and no response received in response to query for target vehicle position.
<i>“RDVZ COMMS”</i>	Entry into the rendezvous state
<i>“MISSION TIMEOUT, TERMINATING”</i>	Overall mission timeout.

Table 1. Modem Messages Initiated by the State Machine

K. RENDEZVOUS QUEUE AND QUEUE MANAGEMENT

The rendezvous queue is an integer array sized to store five rendezvous parameters for each of four rendezvous requests. The size of the queue was based on an assumption that no more than four target vehicles would be involved in the operation, and due to queue management which allows only one queued request per target vehicle. Requests. The five parameters per request are target number, waypoint, progress towards way point, time stamp, and check sum/optimization objective.

The first queue management function, WriteQueue, writes incoming the requests to the queue when they appear in modem shared memory. Because subsequent requests from a queued target vehicle represent updated navigation information and not a request for an additional rendezvous, the process of writing to the queue also involves checking the queue for a previous request from this target vehicle. If no previous request is queued for this vehicle, the request is written to the bottom of the queue, otherwise the previously queued request is overwritten. WriteQueue returns a value which becomes the value of the state machine variable SMevent. If the queue is empty, there are no pending

rendezvous requests and the incoming request should be sent to the mission planning process immediately. Similarly, if the sending vehicle's previous request is at the top of the queue, ARIES is in the process of rendezvousing with the sender of the incoming request. As long as the present state is not RENDEZVOUS, the incoming request should be processed and the rendezvous mission replanned. For these two cases SMevent is set equal to "2", which triggers the mission planning process if ARIES' state is LOITER, CLOSING, or QUERY POSIT. Otherwise it returns the value "6", which causes the contents of the request to be written to the queue.

The queue management function "CheckQueue" is called by RExec while in the loiter state to initiate mission planning. CheckQueue returns "1" if there is a pending rendezvous request in the queue, otherwise it returns "0".

The queue management function "ClearQueue" removes the top request from the queue and promotes all pending requests. It is called upon normal completion of a rendezvous, upon completion of the mission planning when the mission is infeasible, and after an unsuccessful rendezvous when ARIES fails to make contact with the target vehicle and receives no response to its query for target vehicle position.

L. MODEM

The baseline modem process "fm" was rewritten as "Rfm" to support rendezvous operations. Its vocabulary was modified to remove unused message formats and to provide those required. Recognized incoming messages are shown in Table 2. Recognized message headers are "RVS" and "RVQ", corresponding to "set" commands and queries, respectively. The next field in the message is the command, which is followed by command parameters in the case of a rendezvous request. Memory variables were also added to store message parameters. Receipt of any of these messages causes the contents to be written to Rfm shared memory, and for a flag to be set in shared memory to signal the RExec process that a new message has been received. RExec clears this flag after reading the message parameters from Rfm shared memory.

The modem process was also modified to allow the RExec process to initiate modem transmissions, as is necessary when ARIES attempts to contact the target vehicle or transmit status messages. This required the Rfm process to monitor the contents of

MESSAGE	TRANSLATION
<i>“RVS,REQ,a,b,c,d,e”</i>	Rendezvous request from target vehicle a , which is enroute to its b^{th} way point and is located c thousandths of the total length of this leg down track at time d seconds. The sum of the integers $a-d$ is e . The sign of e is positive for a time-optimal rendezvous and negative for an energy-optimal rendezvous.
<i>“RVS,CS”</i>	Start of simulated rendezvous communications
<i>“RVS,CC”</i>	Completion of simulated rendezvous communications
<i>“RVS,ABORT”</i>	Abort. ARIES stops and surfaces.
<i>“RVQ,POSIT”</i>	Query ARIES X,Y position

Table 2. Incoming Messages Recognized by Modem Process

RExec shared memory as well as modem output. Rfm checks the status of a flag in RExec shared memory which signals the presence of an outgoing message, at approximately 20 Hz. When this flag is set, Rfm reads the message from RExec shared memory, clears the flag, and sends the message to the modem to be transmitted.

M. SHARED MEMORY

Shared memory is the primary method of inter-process communications in ARIES. Modifications to shared memory for rendezvous operations consisted of creating a new shared memory segment for the planning process RPlan, and adding new variables to the existing execution and modem process shared memory segments. A diagram of shared memory segments is shown in Fig. 35.

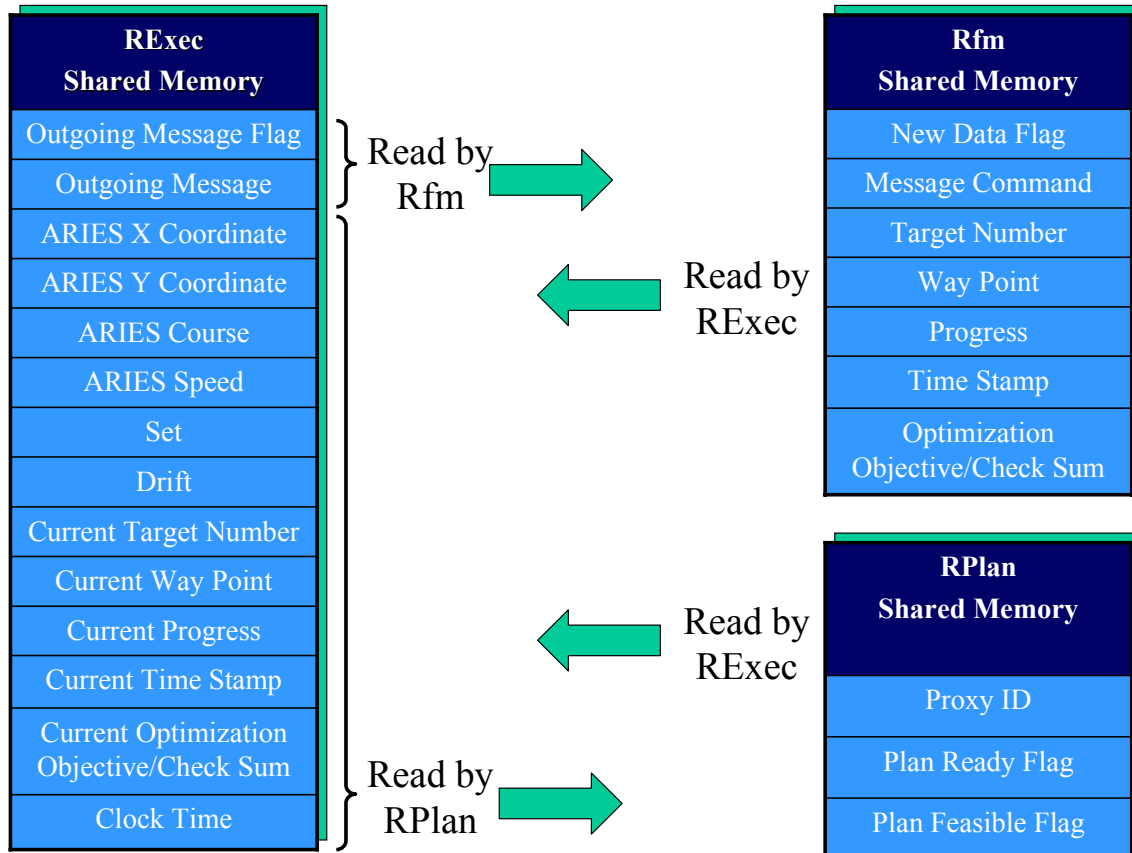

Figure 35. Shared Memory Segments and Variables

The RExec process makes data available to the modem processes Rfm and RPlan. Data made available to the modem consists of a flag to signal the RExec has generated an outgoing modem message and the message itself. RExec sets the flag and Rfm clears the flag once it reads the message. RExec also makes data necessary for mission planning available to RPlan. This data consists of ARIES position, course and speed, target parameters for the target to be rendezvoused with, and clock time. RExec shared memory also makes provisions for passing measured current set and drift, although measurement of these parameters is not yet implemented in RExec code.

Rfm shared memory provides a flag for modem messages similar to that in RExec shared memory. It is cleared by the RExec process once the incoming message is read by RExec. The remaining Rfm shared memory variables store the data contained in the incoming message.

RPlan shared memory contains flags to indicate that the mission plan generated by the planning process is ready, and whether it is feasible. The plan ready flag is cleared by RExec after it reads the flag. Additionally, RPlan shared memory contains the process identification of its proxy. This value must be provided to the RExec process in order for RExec to trigger RPlan's proxy to start the planning process for each rendezvous request.

N. SYSTEM IN-LAB TESTING

The extensive modifications to ARIES software required significant debugging and verification of proper performance. New features and processes were written and tested as isolated modules. However, meaningful complete testing of the integrated system of existing and new code required full-up mission execution. Mission execution normally requires in-water operations, since the lab environment does not provide proper inputs to ARIES' navigation sensors to simulate expected progress through a operational scenario. In the lab environment baseline ARIES software generates multiple mission abort signals because in-lab sensor readings detect events such as failure to reach way points, exceeding minimum allowable altitude above bottom, or thruster failure.

In-water testing also has its limitations. As well as being expensive, labor-intensive, and dependent on weather conditions, it is also less efficient. It is not possible to remain logged on to ARIES' QNXE and QNXT processors during an in-water run since no network connection is available with ARIES underway on a mission. The result is that it is significantly more difficult and time-consuming to monitor mission execution, diagnose improper execution, reboot processors when necessary, and modify and recompile code during in-water ARIES operations.

To overcome these difficulties and accelerate implementation of rendezvous operations, an in-lab testing mode was included in the code for the RExec process. By doing so, the following ARIES protective actions could be temporarily disabled for in-lab testing, then restored for in-water operations:

- Minimum altitude abort: If ARIES altitude above bottom falls below a set minimum, it suspends execution of its mission, turns to a pre-determined course towards deeper water, runs at high speed for a set period, and aborts its

mission. In the lab sensed altitude equals zero since ARIES acoustic doppler current profiler is in air, triggering this abort.

- Way point time out abort: If ARIES position does not satisfy watch radius criteria before expiration of the associated way point time out; a navigation, propulsion, or control failure is assumed. Abort criteria is met and ARIES terminates its mission.

Additionally, in-lab operation of thrusters generally involves running them in air, which risks damaging them due to lack of cooling and lubrication.

The following features were implemented in RExec to overcome these impediments:

- A variable called “LAB” was defined, which is set to “1” for in-lab testing and “0” otherwise. The minimum altitude abort function is enabled only when LAB=0.
- Simulated navigation data is programmed into RExec code which overwrites the navigation data received from the nav process running on QNXT. Data such as (X,Y) position is provided as a function of time to simulate ARIES progressing through a sequence of way points. This not only allows execution of a simulated in-water mission, it prevents activation of the way point timeout abort. Additionally, other parameters can be simulated to verify other features of ARIES software. In particular, the number of GPS satellites received was simulated as a function of time to verify that expected rendezvous mission replanning occurred following GPS fixes.
- Thruster speed command was made to be contingent on the value of LAB. When equal to 1, thruster speed command was reduced by a factor of 10 to permit in-air operation.

In-lab testing consisted of approximately 200 missions to debug ARIES rendezvous software. As a result, with the exception of compass error and a minor

conflict between two methods of periodic mission replanning, ARIES demonstrated expected rendezvous behavior upon its first attempt in-water.

THIS PAGE INTENTIONALLY LEFT BLANK

VI. DEMONSTRATION OF CONCEPT

A. METHODS

Demonstration of ARIES' capability to perform the server vehicle function was accomplished via two methods.

Using the capability to run missions in the laboratory environment developed for this work, rendezvous missions were run in the laboratory with simulated navigation data provided to the vehicle. Navigation data consisted of a pre-programmed sequence of vehicle positions, as well as course, speed, and number of GPS satellites. These simulated parameters provided sufficient input to ARIES rendezvous software to evaluate its performance. All vehicle systems, including thrusters, control surfaces, and sensors operated normally during lab testing. Actual acoustic communications were used for sending commands to ARIES and for ARIES to transmit when required.

Actual in-water missions were used to further demonstrate ARIES' capabilities. Because a second AUV with compatible acoustic communications capabilities was not available, demonstration of the rendezvous concept involved ARIES rendezvousing with a virtual target vehicle. This target consisted of a moving point in space whose position, course, and speed are programmed prior to the run and could be determined in post-run analysis. While target movements were simulated, actual target communications other than high bandwidth data transfer communications were provided by a Benthos acoustic modem controlled by a human operator on a nearby support vessel. It injected all communications that would have been transmitted by the target vehicle, providing simulated target vehicle communications for ARIES to process and respond to. Such communications included actual rendezvous requests as well as short messages signaling the start and completion of simulated high bandwidth data transfer communications. Additional utility messages commanded ARIES to report its position or to abort its mission.

Geometry of the operational area is shown in Fig. 36. For in-water operations, ARIES started in a 100 meter square loiter pattern, periodically obtaining GPS fixes to

maintain navigational accuracy. For laboratory operations it was not necessary for ARIES to maintain headway while awaiting a rendezvous request, so the initial position was a single point.

In all demonstrations the target vehicle was assumed to follow a typical survey pattern of advancing parallel tracks.

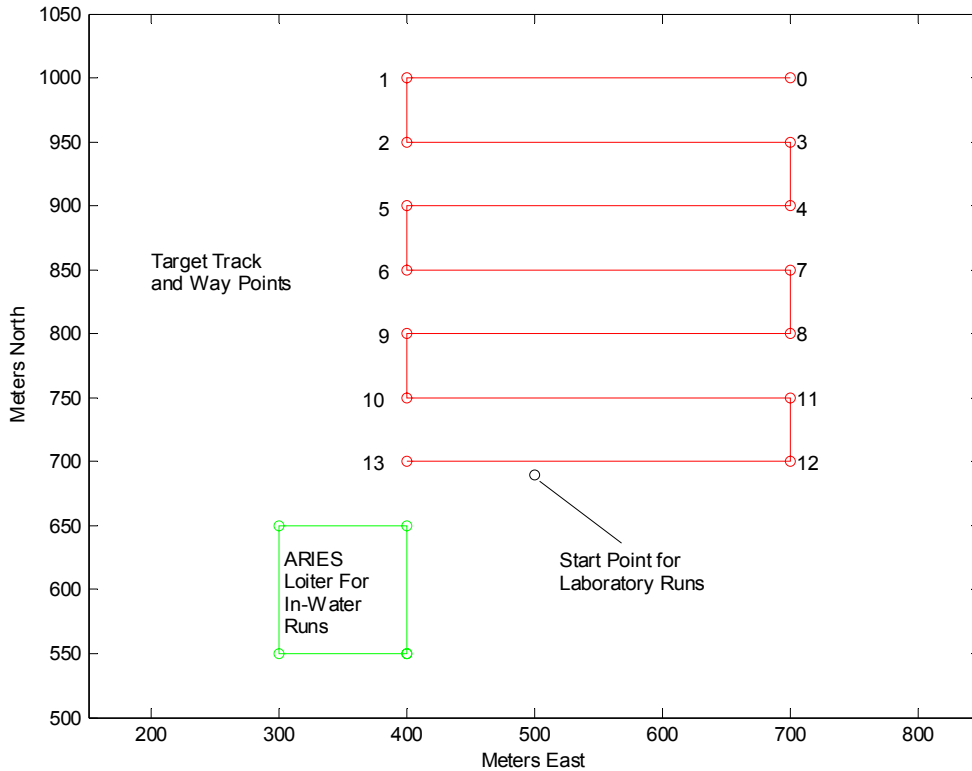

Figure 36. ARIES Demonstration Setup

B. STATE MACHINE AND RENDEZVOUS QUEUE, LABORATORY RUN

Proper operation of the state machine and rendezvous queue was tested early in the development process, first as MATLAB code, then as stand-alone C code on ARIES, and finally as C code integrated with all rendezvous software. All combinations of states and input events were applied to ARIES to verify that proper action was taken when expected, no action was taken when no action was expected, and that repeated occurrences of the same event did not cause ARIES to take repeated actions. Tables 3

through 6 list a sequence of events run in the laboratory and ARIES' correct response to each. ARIES' initial state was LOITER, with the loiter mission plan active.

Event	ARIES Response
1. Invalid rendezvous request	None.
2. Valid rendezvous request	Written to queue. State change to PLAN MSN.
3. Plan is complete, infeasible	State change to LOITER, request cleared from queue.
4. Valid rendezvous request	Written to queue. State change to PLAN MSN.
5. Plan is complete, feasible	State change to CLOSING. Rendezvous plan activated

Table 3. ARIES Laboratory Mission 1, Events 1-5.

Event 1 is a receipt of a rendezvous request that did not meet the parsing criteria of the RExec process. Here that the check sum was incorrect for the remaining data contained in the request. As a result, the request was disregarded and ARIES' operation was unchanged.

Event 2 modified event 1 in that the check sum criteria was met. In response, the request was written to the rendezvous queue by the queue management function WriteQueue. This caused a state transition to PLAN MSN, and processing of the request by the planning process RPlan. Here, the resulting plan did not pass the RPlan feasibility check (event 3). RPlan signaled RExec that the planning process was complete, but that the plan was infeasible. As a result, RExec called the ClearQueue queue management function to remove the request from the queue, and the state changed back to LOITER.

Event 4 modified event 2 in that the resulting plan was feasible (event 5). In response, the state machine set the state to CLOSING and activated the rendezvous mission plan just created by RPlan.

Event 6 was receipt of a signal that rendezvous communications had commenced. This was inserted to verify that no response to this event would take place in the CLOSING state.

Event	ARIES Response
6. Rendezvous comms start	None.
7. Replanning timer expires	State change to PLAN MSN.
8. Plan is complete, feasible	State change to CLOSING.
9. Arrival at rendezvous point	State change to INIT RDVZ. Attempt comms.
10. No comms received from target	State changed to QUERY POSIT. Queries target for present position.
11. No target position received	State change to LOITER, loiter mission plan activated, rendezvous request cleared from queue.

Table 4. ARIES Laboratory Mission 1, Events 6-11.

Event 7 was the expiration of the replanning timer, which occurs when a GPS fix is scheduled during the CLOSING state but no satisfactory fix is obtained. This caused a state transition to the PLAN MSN state, and subsequent reentry to the CLOSING state and activation of the new mission upon successful replanning of the rendezvous mission (event 8).

Event 9 was arrival at rendezvous, which caused transition to the INIT RDVZ state. In this case ARIES attempted to start rendezvous communications, but rendezvous communications were not received from the target vehicle (event 10). This triggered transition to the QUERY POSIT state, wherein ARIES signaled the target vehicle to send an updated rendezvous request. In this case, ARIES received no reply to its query (event 11), causing transition to the LOITER state. Along with the state transition, the loiter mission plan was activated, and the rendezvous request was cleared from the queue.

Event 12 was another valid rendezvous request; which resulted in successful mission planning, transition to the CLOSING state, and activation of the rendezvous mission written in response to this request (event 13). This was followed by event 14, which was a valid rendezvous request from a different target vehicle. Because ARIES was currently enroute to rendezvous with the first target vehicle, this request from a second vehicle was written to the queue for later processing.

Event	ARIES Response
12. Valid rendezvous request	Written to queue. State change to PLAN MSN.
13. Plan is complete, feasible	State change to CLOSING. Rendezvous plan activated
14. Valid rendezvous request from different target	Written to queue under current request.
15. Rendezvous comms complete signal	None.
16. Arrival at rendezvous point	State change to INIT RDVZ. Attempt comms.
17. No comms received from target	State changed to QUERY POSIT. Queries target for present position.
18. Updated target position received	State changed to PLAN MSN
19. Plan is complete, feasible	State change to CLOSING. Updated rendezvous plan activated.

Table 5. ARIES Laboratory Mission 1, Events 12-19.

Event 15 was similar to event 6, an event that should elicit no response from ARIES because ARIES was not in the state for which action should be taken. Because the state was CLOSING, vice RDVZ, no action was taken.

Events 16 and 17 were the same as events 9 and 10, except in this case the target vehicle replied with a new rendezvous request reporting its present status (event 18). This caused another transition to PLAN MSN, and upon event 19 ARIES transitioned back to the CLOSING state and activated the updated rendezvous mission.

Event	ARIES Response
20. Arrival at rendezvous point	State change to INIT RDVZ. Attempt comms.
21. Rendezvous comms start	State change to RDVZ
22. Rendezvous comms complete	Current request cleared from queue. Next request promoted to top of queue. State changed to LOITER, then to PLAN MSN when request noted in queue.
23. Plan is complete, feasible	State changed to CLOSING. Rendezvous plan for second target activated.
24. Mission timer expires	State changed to TERMINATE. Terminate plan activated

Table 6. ARIES Laboratory Mission 1, Events 20-24.

Event 20 was arrival for rendezvous, which in this case was immediately followed by rendezvous communications (event 21). Communications complete was signaled by event 22, which caused transition to the LOITER state, clearing of the rendezvous request from the queue, promotion of the subsequent rendezvous request to the top of the queue, and activation of the loiter mission. However in this case the transition was only momentary, as the state machine detected the presence of a rendezvous request during its next cycle, and ARIES planned and executed the rendezvous for this target vehicle (event 23).

Event 24 was the expiration of the overall mission timer, which immediately activated the terminate mission and causes ARIES to transit to its recovery site.

C. TIME-OPTIMAL RENDEZVOUS, LABORATORY RUN

Having demonstrated the proper functioning of ARIES' state machine and queue management software, laboratory runs were conducted to verify proper functioning of the planning process RPlan and of ARIES in general. The initial configuration of both vehicles is shown in Fig. 37. ARIES was in the LOITER state, on course 000 true, speed 0 meters per second, and the rendezvous queue was empty. The target vehicle was on its fifth mission leg, between way points 4 and 5, on a westerly course, with a speed of 1.0 meters per second.

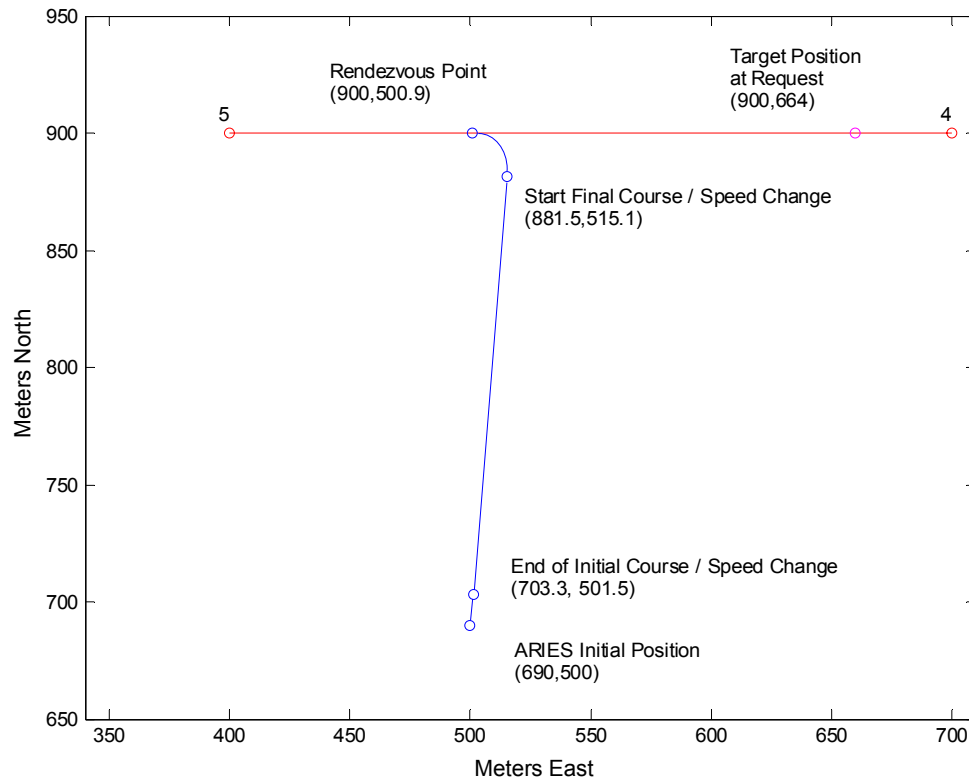

Figure 37. Mission Planning, Time-Optimal Rendezvous, Laboratory Run

At time = 34.25 seconds ARIES received the following message via acoustic modem:

RVS,REQ,0,5,120,30,155

which was parsed by the modem process Rfm as shown in Table 7.

This constitutes a valid message, and was written to the rendezvous queue. With ARIES in the LOITER state and a rendezvous request in the queue with a positive check sum, the state machine triggered the planning process RPlan to build a time-optimal rendezvous plan. The time-optimal mission planning process proceeded as discussed in Ch. V. RPlan retrieved the target vehicle mission from memory, and applied the 4.25 second transmission time delay from generation to receipt

Message Element	Translation
RVS,REQ	Rendezvous request
0	Target vehicle number 0 is the sender of the request
5	Target vehicle is enroute to its waypoint number 5
120	The target vehicle is 120/1000 (12.0%) down the track from its waypoint number 4 to its waypoint number 5
30	The data contained in the rendezvous request are target vehicle parameters at time = 30 seconds. It is 4.25 seconds old
155	Check sum. Since this has a positive value, a time-optimal rendezvous is requested.

Table 7. Parsing of Laboratory Time-Optimal Rendezvous Request

of rendezvous request to the times that it calculated for target vehicle arrival at its previous and subsequent way points. The planning process identified the first way point at which ARIES could feasibly rendezvous with the target vehicle. In this case, it was the present waypoint, waypoint 5. Using the iterative method of finding the time-optimal rendezvous point between this way point and the previous way point, the planning process identified points 1, 2, and 3. Point 3 is the rendezvous point and the point at the end of the second course/speed change. Point 2 is the start of this course / speed change, and point 1 is the end of the first course / speed change. Because the first course / speed change involved a minor 4.33 degree course change but a significant 1.5 meter per

second speed change, its duration was determined by the 13.5 seconds required for ARIES to accelerate. Once on steady course and speed, ARIES trajectory between point 1 and 2 was a straight line 178.7 meters long which, at 1.5 meters per second, could be transited in 119.1 seconds. The final course / speed change was a significant 94.33 degree course change and minor 0.5 meter per second speed change, so its duration was determined by the 26.0 seconds required to complete the turn. As a result, the plan brought ARIES to point 3, the rendezvous point, 158.6 seconds into the future, at which time it should match target vehicle course and speed. Its position along the track at that time was projected to be Y=500.9, which was 0.3 meters ahead of the target vehicle's projected Y=501.2 position. With velocities and positions matched, the vehicles meet the definition of rendezvous.

Using these points, the planning process created the rendezvous mission described by the way point file shown in Table 8, which is in the ARIES format of the previous chapter. The first two way points are points 2 and 3. Note that the distance to the first waypoint is greater than 100 meters, so that a "1" appears in the eighth column to obtain a GPS fix during this leg to update ARIES' position. The final three waypoints are the next three target waypoints, waypoints 5, 6, and 7.

881.50	515.07	3.20	3.20	0	3.00	3.00	1	30.00	1.00	288.14
900.00	500.94	2.13	2.13	0	7.00	3.00	0	1.00	1.00	70.00
900.00	400.00	2.13	2.13	0	7.00	3.00	0	1.00	10.00	450.00
850.00	400.00	2.13	2.13	0	7.00	3.00	0	1.00	10.00	75.00
850.00	700.00	2.13	2.13	0	7.00	3.00	0	1.00	10.00	450.00

Table 8. ARIES Initial Rendezvous Mission, Laboratory Time Optimal Run.

ARIES activated this rendezvous mission, and at time = 75 seconds its simulated position was greater than 30% of the way down the first leg of its rendezvous mission,

which contains a GPS pop-up. Having met GPS pop-up criteria it surfaced, and at that point began to sense the simulated reception of three GPS satellites. In accordance with the GPS reception logic written into the RExec process, after ten seconds of this GPS reception rendezvous mission replanning occurred. The situation is shown in Fig 38. Because ARIES' GPS position was different from its position had precisely followed the course and speed of its rendezvous trajectory, it was necessary to replan the rendezvous based on updated vehicle positions. This is done as it was done above, and the result was a new time-optimal rendezvous point. Note that ARIES position was further from the rendezvous point than was expected, which lengthened the time remaining until the earliest possible rendezvous. As a result, the updated rendezvous is later, 10.6 meters further down the target's track.

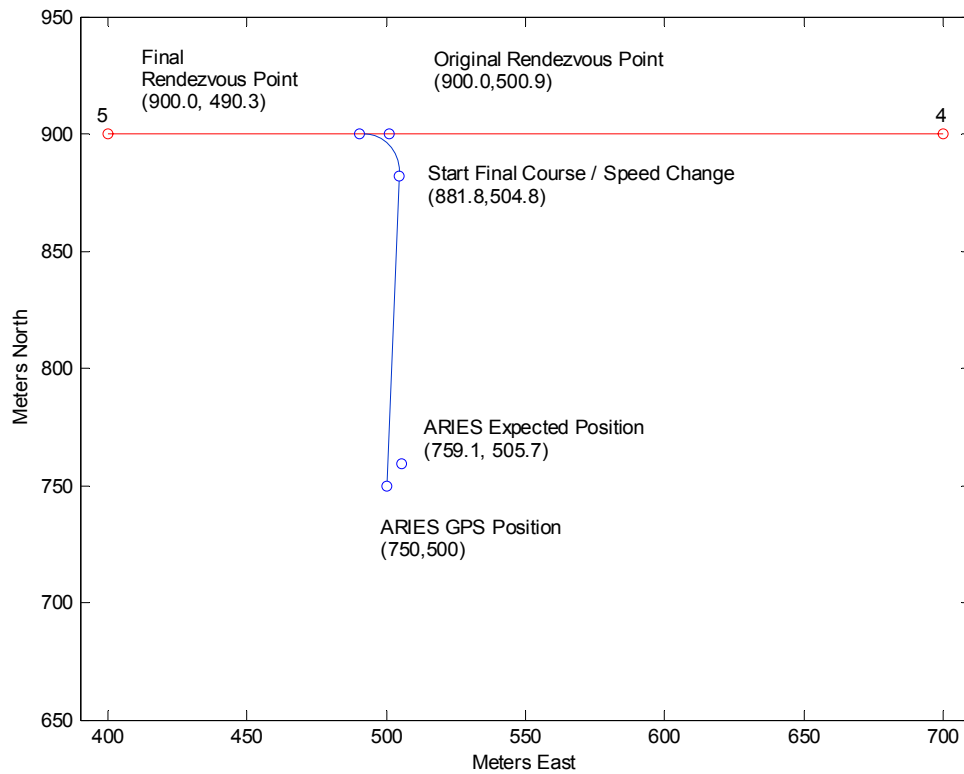

Figure 38. Mission Replanning, Time-Optimal Rendezvous, Laboratory Run.

Following replanning of the rendezvous mission, ARIES continued on to the rendezvous point. The next several events and ARIES responses were nominal, as presented in the previous section and shown in Table 9.

Time (Sec)	Event	ARIES Response
180	Arrival at rendezvous point	State change to INIT RDVZ. Attempt comms.
189	Rendezvous comms start	State change to RDVZ
200	Rendezvous comms complete	Current rendezvous request cleared from queue. State changed to LOITER, loiter mission activated.

Table 9. Events and Responses Following Mission Replanning, Time-Optimal Laboratory Run.

The final event of this run was a GPS popup while ARIES was enroute to the loiter pattern. Since mission replanning applies only to the rendezvous mission and can only occur while ARIES is in the CLOSING state, the loiter mission is unaffected. Although the mission waypoint file remains unchanged, the fix provides data that updates ARIES' position and improves its navigation accuracy.

D. ENERGY-OPTIMAL RENDEZVOUS, LABORATORY RUN

The initial conditions for this run were identical to the time-optimal run. At time = 34 seconds ARIES received the following message via acoustic modem:

RVS,REQ,0,5,120,30,-155

This is identical to the rendezvous request from the time optimal run, except the check sum's negative sign signals that the rendezvous will be planned as energy optimal. As discussed in Ch. V, the initial portion of the energy-optimal planning process is to determine the time-optimal rendezvous point, which establishes the earliest bound on the time period during which an energy optimal rendezvous may occur. Because the target vehicle position data contained in this rendezvous request is identical to the time-optimal

case, and the time delay for receiving this request was only 0.25 seconds different from the time-optimal case, the earliest possible energy-optimal rendezvous point was essentially the original time-optimal rendezvous point bound from the previous case. Therefore the earliest possible rendezvous occurred on target mission leg 5.

As discussed in Ch. V, the latest possible energy-optimal rendezvous is found as the time optimal rendezvous for ARIES' lowest speed, 1.0 meters per second. Sampling the target track every 20 meters between these two bounds and determining the energy required for rendezvous at each point yielded the point (900,420) as the energy optimal rendezvous point, as shown in Fig. 39.

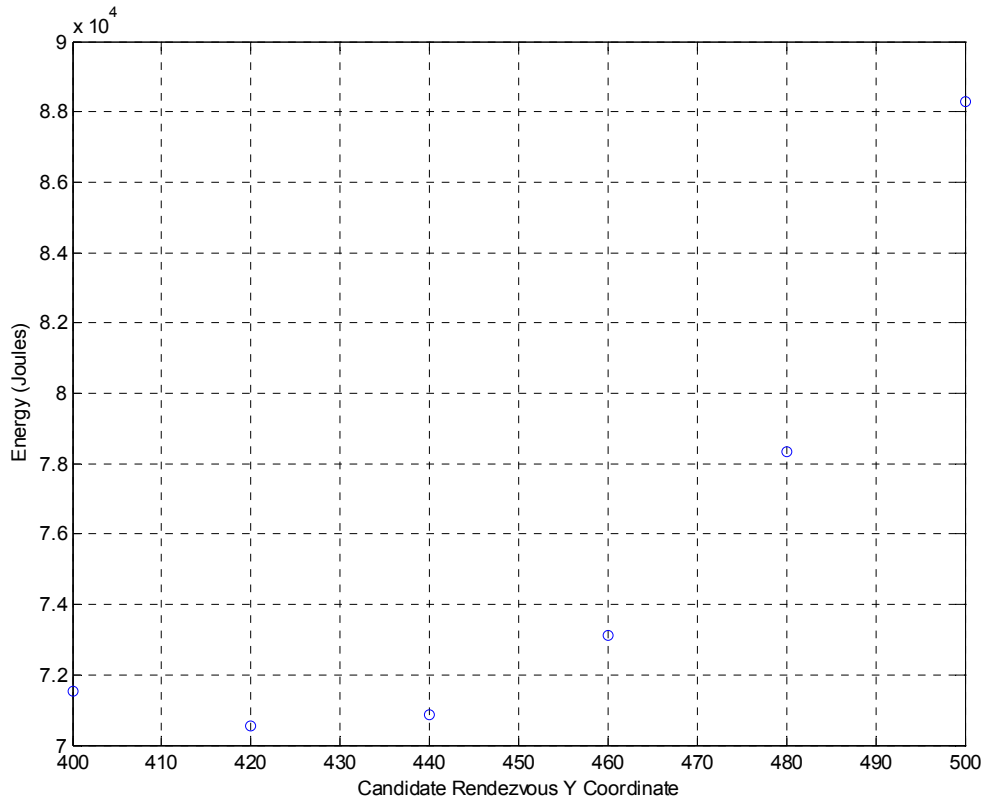

Figure 39. Energy to Rendezvous versus Rendezvous Position, Energy-Optimal Laboratory Run

After locating the energy-optimal rendezvous point, the planning process built the rendezvous mission waypoint file to get ARIES to the rendezvous point. This planning

process is similar to that used in the time-optimal case, except instead of adjusting the rendezvous point location with closure speed fixed, closure speed is adjusted while holding the rendezvous point fixed. The process is illustrated in Fig. 40.

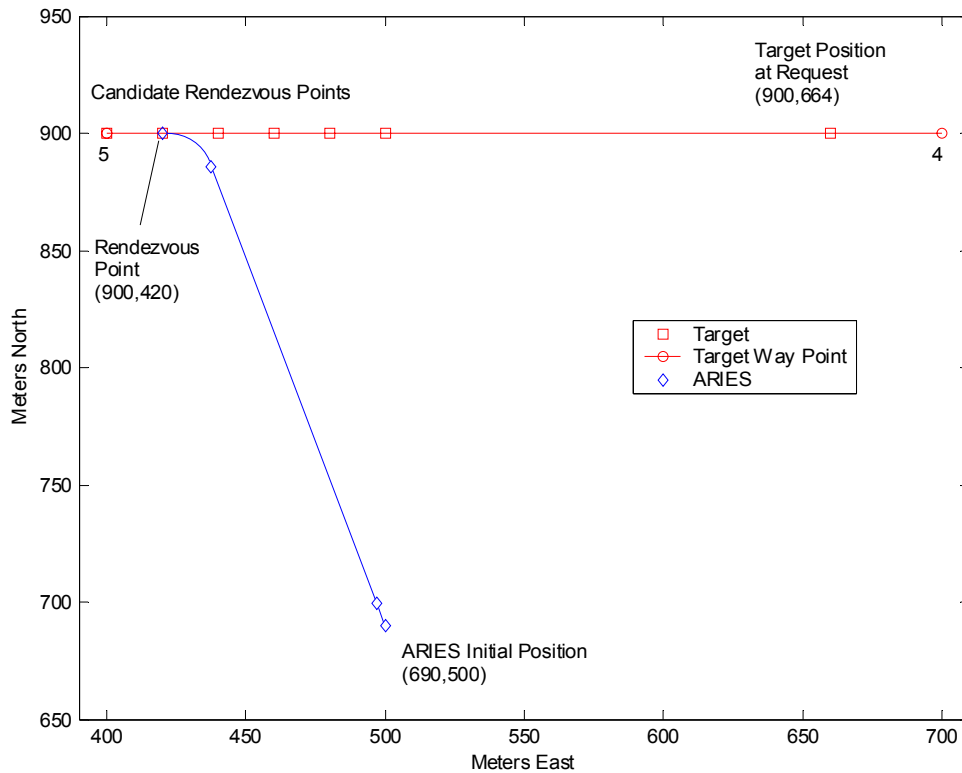

Figure 40. Mission Planning, Energy-Optimal Rendezvous, Laboratory Run

After ARIES activated the rendezvous mission, the rendezvous proceeded as in the time-optimal case, with the mission replanned once in response to a GPS fix.

E. TIME-OPTIMAL RENDEZVOUS, IN-WATER RUN

The initial in-water time optimal run is depicted in Fig. 41. ARIES began the run in the loiter state, traversing its loiter pattern in a clockwise direction and fixing its position with GPS periodically. At time = 662.125 seconds, ARIES received the following rendezvous request from target number 2:

2,2,96,660,760

This request parses to a time-optimal request from target #2, located 9.60% of the way between its waypoints 1 and 2 at time 660 seconds. As before the planning process identified the time-optimal rendezvous point, which in this case was located on the third leg of the target's mission. The mission was feasible and ARIES departed its loiter pattern to begin closing the rendezvous point.

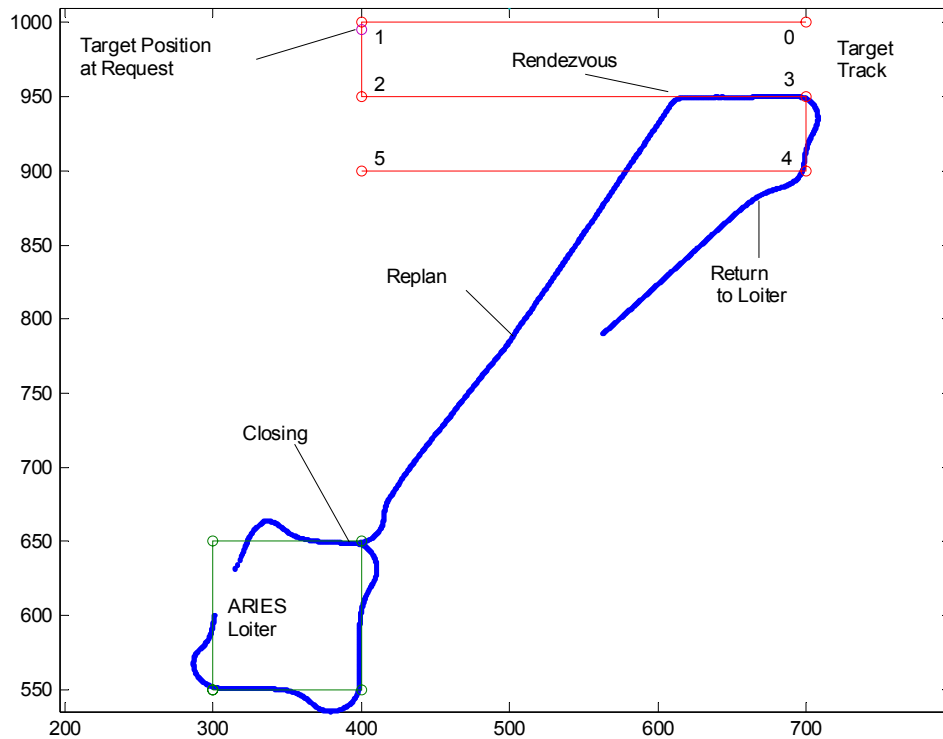

Figure 41. Time-Optimal Rendezvous, In-Water Run

At time = 782.375 seconds ARIES replanned the rendezvous mission. During closure ARIES actual speed through the water had been 1.6 meters per second, not 1.5 meters per second as planned by the planning process. This was due to ARIES' open-loop speed control. Ballasting and hydrodynamic variations resulted in a higher than expected speed. Mission replanning took this speed difference into account, adjusting the rendezvous point for ARIES actual position which was further down track than expected;

and using the better-than expected progress towards the rendezvous point to plan a new, earlier rendezvous. The result was a four degree course adjustment to the left, towards the earlier rendezvous point.

At time $t = 909$ seconds ARIES arrived at the rendezvous point $X=950, Y=617.3$. Projecting the target vehicle's rendezvous request position forward to this time, its position would be $X=950, Y=903.8$. Therefore ARIES arrived approximately 5.2 meters ahead of expected position of the target vehicle. This miss distance is within range of all present high-speed underwater communications systems, and was primarily due to the speed error during closure. ARIES' accumulated position error due to the 0.1 meter per second speed error during the 127 seconds of closure since mission replanning would have been approximately 13 meters.

ARIES controls and state responses are shown in Fig. 42. As discussed in Ch. III, rudder control is “bang-singular-bang” while enroute to rendezvous, with approximately zero rudder during the singular arc. Speed control is “bang-bang”.

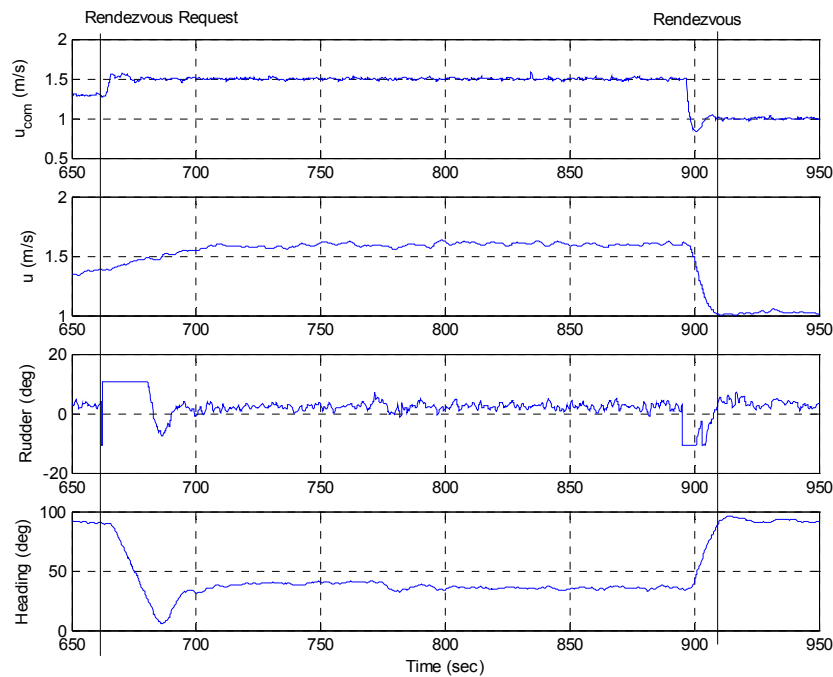

Figure 42. ARIES Speed Command and Speed, Rudder Angle, and Heading, Time-Optimal Rendezvous, In-Water Run

ARIES rendezvoused with the target for 120 seconds. At the rendezvous point ARIES unsuccessfully attempted to establish rendezvous communications, which were provided by a modem-equipped support vessel. As a result, ARIES queried for target vehicle position at time = 976.625 seconds. When no reply was received by time = 1036 seconds ARIES abandoned the rendezvous attempt, as directed by the state machine, and returned to its loiter area.

F. ENERGY-OPTIMAL RENDEZVOUS, IN-WATER RUN

The initial in-water energy-optimal run is depicted in Fig. 43.

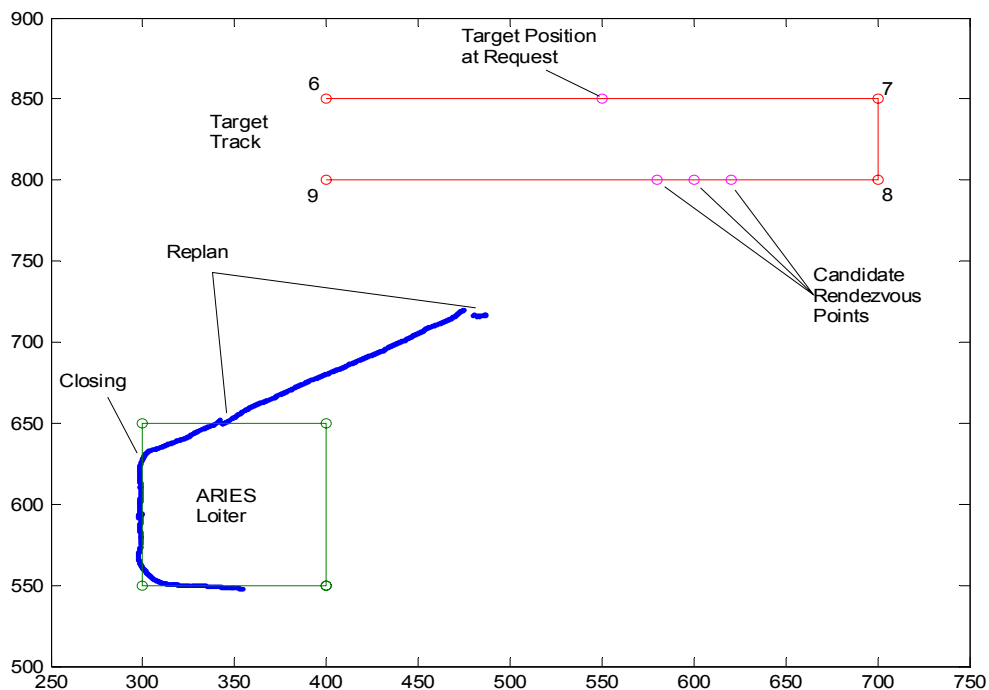

Figure 43. Closure for Energy Optimal Rendezvous, In-Water Run

ARIES again started in its loiter pattern. At time = 242 seconds it received the rendezvous request

RVS,REQ,0,7,500,240,-747

which signaled that the target number 0 was 50% of the way down its seventh leg at time 240 seconds, and that the rendezvous will be energy optimal. The planning process identified three candidate rendezvous points at which rendezvous fell within ARIES

speed range. The leftmost point required the least energy, and rendezvous was planned for that point. Replanning occurred at two later times based on reception of satisfactory GPS fixes scheduled to occur at those points. The first replanning resulted in selection of the same rendezvous point as initial planning. Due to variations in actual ARIES speed and external disturbances during closure, the second replanning process selected the center candidate rendezvous point. Shortly after this final replanning of the rendezvous, ARIES aborted its mission due to inadequate battery power for propulsion. Projection of ARIES' and the target's future movements indicated that the vehicles would have rendezvoused within approximately 30 meters.

THIS PAGE INTENTIONALLY LEFT BLANK

VII. CONCLUSION

A. SUMMARY

This work develops a high-bandwidth concept for accelerating access to information gathered by AUVs. This cooperative behavior enhances AUV operations and increases their value and effectiveness in networked naval operations as envisioned in the CNO's "Sea Power 21" guidance for future Naval operations.

The data transfer method utilizes rendezvous between AUVs to enable the use of high bandwidth optical or acoustic communications links between vehicles. A server vehicle, whose role is to transfer survey data from sensor vehicles to a larger network, comes into close proximity with a sensor vehicle to receive the data. This is necessary because high bandwidth underwater communications methods are of limited range, This concept also provides a greater degree of covertness than radio links with the sensor vehicle.

Because of limitations on AUV energy resources, and because access to such data may be time-sensitive, efficiency is a goal of the rendezvous process. Since most literature on rendezvous deals with spacecraft operations, intercept methods were investigated for application to AUV rendezvous. Intercept is similar to rendezvous in that the goal is to match the future position of a target vehicle. Rendezvous imposes the additional constraint that target vehicle be matched as well. Doing so brings both vehicles in close proximity with no relative motion such that communications can be exchanged. The relative merits of intercept methods are dependent on the geometry of the particular problem, owing to the lack of information on target maneuvers during the intercept. This work demonstrates how such information, which should be available between cooperating vehicles, enhances the efficiency of the rendezvous process.

Efficiency was then defined as time-optimal or energy-optimal rendezvous, depending on whether the objective is the most rapid access to data or conservation of vehicle energy reserves. Using principles of optimal control, the characteristics of the optimal rendezvous trajectories were determined for both cases. For time optimal rendezvous the solution was found to be bang-singular-bang rudder control and bang-

bang speed control. The chaser vehicle immediately accelerates to and maintains maximum speed until such time that stopping propulsion causes the vehicle to decelerate to target vehicle speed at the rendezvous point. It also executes two course changes, using maximum rudder until on a heading to close the target vehicle and remaining on this heading until a final maximum rudder turn that brings it to the position and heading of the target vehicle at the same speed. The rendezvous point is uniquely defined as the earliest for which the target vehicle's state fall into the set of chaser vehicle reachable states. In order to determine the energy-optimal rendezvous trajectory, the vehicle's power requirement as a function of speed must be known. Installation of a current sensor in the NPS ARIES vehicle made this possible for the ARIES vehicle, and data showed that the vehicle's power characteristics are a typical combination of a constant hotel load and a cubic propulsion load. The energy-optimal rendezvous solution involves bang-singular-bang control of both speed and rudder. Rudder control is similar to the time-optimal case, while speed control involves a final speed change to match target speed and an initial speed change to a most-efficient speed to close the target. This speed is dependent on problem geometry, and may not be attainable due to lower limits on vehicle speed imposed by vehicle buoyancy and control considerations. The minimum energy solution is not unique, but operational considerations would probably drive towards selecting the earliest of multiple solutions.

These solutions were then implemented by upgrading the operational software of the ARIES vehicle to allow it to perform the server vehicle function. Whereas ARIES is a typical AUV utilizing autopilots for vehicle control and mission scripts and way point files to define a mission, rendezvous requires a higher level operational control. In order to rendezvous, ARIES must communicate effectively with the other vehicle, must plan its mission based on information received from the other vehicle, must activate the mission and follow it to the rendezvous point, must periodically replan the rendezvous mission to account for navigational changes enroute, must provide a level of robustness to deal with navigational and communications failures, and must properly sequence this complex collection of activities.

ARIES communications software was upgraded to allow exchange of rendezvous information and to allow ARIES to initiate communications.

A mission planning module was written to process incoming requests to rendezvous, combine the information contained in the request with pre-stored target vehicle mission parameters, and generate a rendezvous mission waypoint file to bring ARIES efficiently to the rendezvous point in either a time-optimal or energy-optimal manner.

ARIES mission activation software was rewritten to allow activation of way point files whenever appropriate, rather than only at the start of a mission as is typically the case with AUV missions. Additionally a rendezvous queue, along with queue management routines, was added to coordinate the processing of requests from multiple target vehicles.

To coordinate ARIES' rendezvous operations an additional layer of control was added. A finite state machine was implemented which defined the rendezvous mission as a series of seven states. The state machine defined a series of mission events, and ordered state transitions to occur whenever transition criteria were met.

ARIES proper functioning as a server vehicle capable of rendezvousing with other vehicles was then verified. A laboratory operational mode was developed for ARIES, allowing ARIES to run simulated missions in the laboratory environment. This greatly reduced the amount of time needed to debug the significant code changes necessary to perform rendezvous operations, and provided a means to demonstrate ARIES proper operation as a rendezvous-capable server vehicle. In-water runs with a surrogate target vehicle and using a support vessel to provide communications inputs to ARIES further demonstrated ARIES correct functioning as a server vehicle.

B. RECOMMENDATIONS

This work developed and demonstrated the server vehicle rendezvous behavior on the ARIES AUV, however an operational system would require the following additional developments.

A high bandwidth communications link should be installed on the server vehicle to provide the high-speed data transfer capability that is the motivation for this work.

Implementation of closed-loop control of server vehicle speed would improve navigation to the rendezvous point. This implementation used open-loop speed control based on previous determination of the relationship between steady-state thruster and vehicle speeds. Closing this loop, particularly for energy-optimal rendezvous, would improve the server vehicle's ability to reach the rendezvous point at the computed time of rendezvous. In the time-optimal case, since the objective is to rendezvous as soon as possible, a logical and analogous improvement would be to command maximum vehicle speed as was done here, but to use actual measured speed in the rendezvous planning process. This would still provide minimum-time transit to the rendezvous point, while providing more accurate data to the planning process.

Because of the limited range of high-bandwidth underwater communications equipment, it would be beneficial for server vehicle navigation to shift to a mode based on sensed survey vehicle position once rendezvous is achieved. The implementation presented here is based on a global frame of reference for both vehicles, wherein the accuracy with which the server vehicle can close the survey vehicle is affected by the global position uncertainty of both vehicles. At best, several meters of error would be expected if using typical global navigation methods such as GPS or long-baseline acoustic navigation. However once the rendezvous point is reached using a global reference frame, if the server vehicle is able to sense the position of the survey vehicle directly and shift to a navigation frame of reference centered on it, the server vehicle should be able to control its position relative to the survey vehicle with accuracy superior that of the global reference frame. This may be necessary for extremely short range or highly directional communications systems.

Compatible survey vehicles must be added to the operation to create the vehicle network. Such vehicles should be configured with both command-and-control mode and rendezvous mode communications equipment, and this equipment must be integrated with the vehicle's processors. Vehicle logic must determine when an event warranting transmission of a rendezvous request has occurred, determine vehicle state, generate the

request containing the state information, and transmit it. Logic should also determine when to issue subsequent rendezvous requests if rendezvous does not occur. Rendezvous mode communications equipment must be integrated with the sensors gathering survey data, to transfer the data once rendezvous commences.

Survey vehicles should also be dynamically compatible with the server vehicle so that rendezvous is possible. The survey vehicle should not operate at speeds greater than the server vehicle, and turn dynamics should be compatible so that rendezvous operations are not unduly disrupted during turns. Additionally, for directional communications systems, the motions of both vehicles must be controlled to avoid disruption of the communications link during data transfer.

THIS PAGE INTENTIONALLY LEFT BLANK

LIST OF REFERENCES

- Andrews, Frank (2004). *The Thresher Debris Field*, Submarine Review, April.
- Bak, Richard (1999). *The CSS Hunley – The Greatest Undersea Adventure of the Civil War*. Dallas: Taylor Publishing.
- Betts, John T. (2001). *Practical Methods for Optimal Control Using Nonlinear Programming*. Philadelphia: Society for Industrial and Applied Mathematics.
- Bongiorno, Joseph J. Jr. (1967) *Minimum-Energy Control of a Second-Order Non-Linear System*, IEEE Transactions on Automatic Control, Vol AC-12, pp. 249-255.
- Bryson, Arthur E. (1999). *Dynamic Optimization*. Menlo Park, California: Addison Wesley Longman.
- Chance, Thomas S. and Northcutt, Jay (2001). *Deep Water AUV Experiences*, retrieved June 28, 2004 from http://www.cctechnol.com/papers/deepwater_exp.pdf.
- Clark, Vern (2002). *Sea Power 21: Projecting Decisive Joint Capabilities*, Proceedings of the United States Naval Institute, Vol 128, pp. 32-41.
- Curtin, Thomas B. and Bellingham, James G. (2001) *Guest Editorial: Autonomous Sampling Networks*, IEEE Journal of Oceanic Engineering, Vol 26, pp. 421-423.
- Department of the Navy (2000). *The Navy Unmanned Undersea Vehicle (UUV Master Plan)*. Retrieved June 28, 2004 from <http://www.auvsi.org/resources/UUVMPPubRelease.pdf>.
- Etter, Paul C. (1996). *Underwater Acoustic Modeling*. London: E & FN Spon.
- Gray, Edwyn (1991). *The Devil's Device – Robert Whitehead and the History of the Torpedo*. Annapolis, Maryland: Naval Institute Press.
- Hatley, Derek; Hruschka, Peter; and Pirbhai, Imtiaz (2000). *Process for System Architecture and Requirements Engineering*. New York: Dorset House.
- Healey, Anthony J. (1995). *Dynamics and Control of Marine Vehicles - ME4823 Course Notes*.
- Hohmann, J. (1925). *The Attainability of Heavenly Bodies*, *NASA Technical Translation F.44, (1960)* Munich: Oldenbourg.

Hutchins, R.G., Roque, J.P.C. (1995). *Filtering and Control of An Autonomous Underwater Vehicle for Both Target Intercept and Control*. Proceedings of the 4th IEEE Conference on Control Applications, Albany New York, pp. 1162-1163.

Kirk, Donald E. (1970). *Optimal Control Theory – An Introduction*. Englewood Cliffs, New Jersey: Prentice-Hall

Johnson, Jay H. (2001). *AUV Steering Parameter Identification For Improved Control Design*. MSME Thesis, Monterey California: Naval Postgraduate School.

Jones, Daren (2002) *The AUV Marketplace*, Underwater Magazine, July/August.

Kojima, J. et al (2002, April) *High Speed Acoustic Data Link Transmitting Moving Pictures for Autonomous Underwater Vehicles*, Proceedings of the 2002 Symposium on Underwater Technology, pp. 278-283.

Kwak, S.H., McGhee, R.B., and Bihari, T.E. (1992) *Rational Behavior Model: A Tri-Level Multiple Paradigm Architecture for Robot Vehicle Control Software* Monterey, California: Naval Postgraduate School.

Lacovara, Philip (2003). *High Data-Rate Optical Communications (HDROC) Pier Test Report, Report number R1009-02*. Ambalux Corporation.

Marco, David B. (2001). *Procedure to Run Missions with ARIES*.

Marco, David B., and Healey, Anthony J. (2000, September) *Current Developments in Underwater Vehicle Control and Navigation: The NPS ARIES AUV*, OCEANS 2000 MTS/IEEE Conference and Exhibition, Providence, Rhode Island, pp 1011-1016.

Marr, William J. (2003) *Acoustic Based Tactical Control of Underwater Vehicles*. Ph.D. Dissertation, Monterey California: Naval Postgraduate School

Marec, Jean-Pierre (1979). *Optimal Space Trajectories*. Amsterdam: Elsevier.

Mehrandezh, M., Sela, M.N., Fenton, R.G., Benhabib, B., (1999, May) *Proportional Navigation Guidance in Robot Trajectory Planning for Intercepting Moving Objects*. Proceedings of the 1999 IEEE International Conference on Robotics & Automation, Detroit, Michigan, pp.145-150.

McConnell, Anita (1982). *No Sea Too Deep – The History of Oceanographic Instruments*. Bristol, England: Adam Hilger Ltd.

Naval Undersea Warfare Center (1998). *A Century of Progress – A History of Torpedo System Development*.

Peterson, Craig A. and Head, Martha E. M. (2002) “Seahorses and Submarines: Testing Transformational Capabilities With UUVs at NAVOCEANO”, *Undersea Warfare*, Vol 5.

Pontryagin, L. S., Boltyanskii, V. G., Gamkrelidze, R. V. , Mishchenko, E. F. (1962). *The Mathematical Theory of Optimal Processes*, Moscow, 1961, translated by K. N. Trirgoff, L. W. Neustadt (Ed), New York: Interscience.

Marine Technology Society. *A Brief History of ROVs*. Retrieved November 11, 2003 from <http://www.rov.org/education/pages/history.html>.

Shkel, Andrei M. and Luelsky, Vladimir (2001). “Classification of the Dubins Set”, *Robotics and Autonomous Systems*, Vol 34, pp. 179-202.

Triantafyllou, Michael S., Hover, Franz S. (2002). *Maneuvering and Control of Marine Vehicles*. Cambridge, Massachusetts: Massachusetts Institute of Technology.

Urich, R. and Walton, J. (1995, September). *Supervisory Control of Untethered Undersea System: A New Paradigm Verified*. Ninth International Symposium on Unmanned Untethered Submersible Technology, Durham, New Hampshire.

Wernli, Robert L. (1997, October). “Trends in UUV Development within the U.S. Navy”, OCEANS '97 Conference proceedings, Halifax, Nova Scotia, pp. 841-848.

Zarchan, Paul (2002). *Tactical and Strategic Missile Guidance*. Washington: American Institute of Aeronautics and Astronautics.

THIS PAGE INTENTIONALLY LEFT BLANK

INITIAL DISTRIBUTION LIST

1. Defense Technical Information Center
Ft. Belvoir, VA
2. Dudley Knox Library
Naval Postgraduate School
Monterey, CA
3. Distinguished Professor Anthony J. Healey
Department of Mechanical Engineering
Naval Postgraduate School
Monterey, CA
4. Associate Professor Joshua Gordis
Department of Mechanical Engineering
Naval Postgraduate School
Monterey, CA
5. Associate Professor Fotis Papoulias
Department of Mechanical Engineering
Naval Postgraduate School
Monterey, CA
6. Associate Professor Wei Kang
Department of Mathematics
Naval Postgraduate School
Monterey, CA
7. Professor Young Kwon
Department of Mechanical Engineering
Southern Illinois University
Carbondale, IL
8. Dr. Thomas Swean
Office of Naval Research
Arlington, VA
9. Dr. Thomas Curtin
Office of Naval Research
Arlington, VA

10. Dr. Doug Todoroff
Office of Naval Research
Arlington, VA
11. Dr. James Bellingham
Monterey Bay Aquarium Research Institute
Moss Landing, CA
12. Mr. John Lisiewicz
Naval Undersea Warfare Center
Newport, RI
13. Mr. Chris VonAlt
Woods Hole Oceanographic Institution
Woods Hole, MA