



2003-06

Analysis of the ship ops model's accuracy in predicting U.S. Naval ship operating cost

Hascall, Andrew M.

Monterey, California. Naval Postgraduate School



Calhoun is a project of the Dudley Knox Library at NPS, furthering the precepts and goals of open government and government transparency. All information contained herein has been approved for release by the NPS Public Affairs Officer.

**Dudley Knox Library / Naval Postgraduate School
411 Dyer Road / 1 University Circle
Monterey, California USA 93943**



NAVAL
POSTGRADUATE
SCHOOL

MONTEREY, CALIFORNIA

MBA PROFESSIONAL REPORT

**Analysis of the Ship Ops Model's Accuracy in Predicting U. S. Naval
Ship Operating Cost**

**By: Andrew M. Hascall
Andrew M. Matthews
Mihaly Gyarmati
William K. Gantt and
Zsolt Hajdu**

June 2003

**Advisors: Shu Liao,
John Mutty**

Approved for public release; distribution is unlimited

THIS PAGE INTENTIONALLY LEFT BLANK

REPORT DOCUMENTATION PAGE			Form Approved OMB No. 0704-0188	
Public reporting burden for this collection of information is estimated to average 1 hour per response, including the time for reviewing instruction, searching existing data sources, gathering and maintaining the data needed, and completing and reviewing the collection of information. Send comments regarding this burden estimate or any other aspect of this collection of information, including suggestions for reducing this burden, to Washington headquarters Services, Directorate for Information Operations and Reports, 1215 Jefferson Davis Highway, Suite 1204, Arlington, VA 22202-4302, and to the Office of Management and Budget, Paperwork Reduction Project (0704-0188) Washington DC 20503.				
1. AGENCY USE ONLY (Leave blank)		2. REPORT DATE June 2003	3. REPORT TYPE AND DATES COVERED MBA Professional Report	
4. TITLE AND SUBTITLE: Analysis of the Ship Ops Model's Accuracy in Predicting U. S. Naval Ship Operating Cost			5. FUNDING NUMBERS	
6. AUTHOR(S): William K. Gantt, Mihaly Gyarmati, Zsolt Hajdu, Andrew M. Hascall, Andrew M. Matthews				
7. PERFORMING ORGANIZATION NAME(S) AND ADDRESS(ES) Naval Postgraduate School Monterey, CA 93943-5000			8. PERFORMING ORGANIZATION REPORT NUMBER	
9. SPONSORING / MONITORING AGENCY NAME(S) AND ADDRESS(ES) N/A			10. SPONSORING / MONITORING AGENCY REPORT NUMBER	
11. SUPPLEMENTARY NOTES The views expressed in this report are those of the author(s) and do not reflect the official policy or position of the Department of Defense or the U.S. Government.				
12a. DISTRIBUTION / AVAILABILITY STATEMENT Approved for public release; distribution is unlimited.			12b. DISTRIBUTION CODE	
13. ABSTRACT (maximum 200 words) The purpose of this MBA Project was to investigate and provide a comprehensive analysis of the accuracy of the Ship Ops model used by the US Navy to budget for ship-operating costs. This project was conducted with the sponsorship and assistance of the OPNAV N82 office, also known as the Office of Budget (FMB). The goal of this project was to improve FMB's ability to predict ship-operating costs through the use of an improved Ship Ops model. This project provides an in depth introduction to the Ship Ops model currently in use and an analysis of the model's performance in predicting accurate operating costs. The project also provides suggestions for improvements to the model and tools that can be used to predict costs on an individual ship level that is not possible with the current model. This project observed only limited improvements in predicting Repair Parts and OPTAR cost through the use of regressions based on operational data such as days underway. Significant improvement was observed when the current moving average methodology for predicting Repair Parts cost was replaced with a regression-based prediction based on a sequential independent variable, Fiscal Year.				
14. SUBJECT TERMS Cost Analysis, Cost Estimates, Forecasting, Navy, Naval Vessels (Combatant), Operating and Support Costs.			15. NUMBER OF PAGES 305	
			16. PRICE CODE	
17. SECURITY CLASSIFICATION OF REPORT Unclassified	18. SECURITY CLASSIFICATION OF THIS PAGE Unclassified	19. SECURITY CLASSIFICATION OF ABSTRACT Unclassified	20. LIMITATION OF ABSTRACT UL	

THIS PAGE INTENTIONALLY LEFT BLANK

Approved for public release; distribution is unlimited

**ANALYSIS OF THE SHIP OPS MODEL'S ACCURACY IN PRE-
DICTING U.S. NAVAL SHIP OPERATING COST**

William K. Gantt, Lieutenant, United States Navy
Mihaly Gyarmati, Captain, Hungarian Army
Zsolt Hajdu, 1st Lieutenant, Hungarian Army
Andrew M. Hascall, Lieutenant Commander, United States Navy
Andrew M. Matthews, Lieutenant Commander, United States Navy

Submitted in partial fulfillment
of the requirements for the degree of

MASTERS OF BUSINESS ADMINISTRATION

from the

**NAVAL POSTGRADUATE SCHOOL
June 2003**

Authors:

William K. Gantt

Mihaly Gyarmati

Zsolt Hajdu

Andrew M. Hascall

Andrew M. Matthews

Approved by:

Shu Liao
Lead Advisor

John Mutty
Support Advisor

Douglas A. Brook, Dean
Graduate School of Business and Public Policy

THIS PAGE INTENTIONALLY LEFT BLANK

ANALYSIS OF THE SHIP OPS MODEL'S ACCURACY IN PREDICTING U.S. NAVAL SHIP OPERATING COST

ABSTRACT

The purpose of this MBA Project was to investigate and provide a comprehensive analysis of the accuracy of the Ship Ops model used by the US Navy to budget for ship-operating costs. This project was conducted with the sponsorship and assistance of the OPNAV N82 office, also known as the Office of Budget (FMB). The goal of this project was to improve FMB's ability to predict ship-operating costs through the use of an improved Ship Ops model. This project provides an in depth introduction to the Ship Ops model currently in use and an analysis of the model's performance in predicting accurate operating costs. The project also provides suggestions for improvements to the model and tools that can be used to predict costs on an individual ship level that is not possible with the current model. This project observed only limited improvements in predicting Repair Parts and OPTAR cost through the use of regressions based on operational data such as days underway. Significant improvement was observed when the current moving average methodology for predicting Repair Parts cost was replaced with a regression-based prediction based on a sequential independent variable, Fiscal Year.

THIS PAGE INTENTIONALLY LEFT BLANK

TABLE OF CONTENTS

I. INTRODUCTION	1
A. BACKGROUND	1
B. RESEARCH DISCUSSION	3
C. OBJECTIVES	3
D. ORGANIZATION OF THE PAPER.....	3
II. CURRENT MODEL	5
A. DESCRIPTION.....	5
1. Feeder Sheets	6
2. Calculation Sheets.....	9
3. Info Sheets	11
4. Summary Sheets.....	12
B. USE AND LIMITATIONS.....	12
III. DATA COLLECTION	15
A. REVIEW OF PREVIOUS STUDIES.....	15
B. COST DATA	16
C. EMPLOYMENT DATA.....	17
D. SHIP CLASSES CHOSEN.....	18
IV. DATA ANALYSIS	21
A. METHODOLOGY	21
B. APPLICATION	25
C. RESULTS	26
V. MODIFIED MODEL PROPOSAL	35
A. INTRODUCTION	35
B. DEVELOPING THE MODIFIED MODEL.....	36
C. EVALUATING OUR MODEL.....	39
D. RESULTS	50
VI. CONCLUSIONS AND RECOMENDATIONS.....	51
A. CONCLUSIONS.....	51

B. RECOMMENDATIONS.....	51
C. AREAS FOR FUTURE RESEARCH	51
1. Alternative Models.....	51
2. Submarines.....	52
3. SF & SU.....	52
4. Monte Carlo Simulation.....	52
5. Analysis of the Data Input Process.....	52
APPENDIX A: SHIP OPS MODEL EXAMPLE CALCULATIONS	53
A. APPENDIX DESCRIPTION.....	53
B. USEFUL DEFINITIONS.....	53
C. FEEDER SHEETS.....	55
1. OP-41 List.....	55
2. FY-CL-RS Constants.....	55
3. FY-CL-Constants.....	56
4. Burn Rates.....	57
D. CALCULATION SHEETS	57
1. Fuel (SF)	57
2. Counter Terrorism (CT).....	62
3. Repair Parts (SR)	63
4. Other Consumables (SO).....	65
5. Utilities.....	66
6. No Special Interest Items (NSI).....	67
APPENDIX B: CURRENT MODEL ANALYSIS METHODOLOGY	69
APPENDIX C: SUMMARY OF SIGNIFICANT REGRESSIONS WITH MAPE.....	121
AOE-1 Class.....	123
AOE-6 Class.....	124
ARS Class	126
CG-47 Class	128
CVN-68 Class	130
DD-963 Class	132
DDG-51 Class	134
FFG Class.....	137
LHA-1 Class.....	140
LHD Class.....	142

LPD Class.....	144
LSD-36 Class	146
LSD-41 Class	148
MCM Class	150
MHC Class	152
APPENDIX D: SUMMARY OF SHIP CLASS REGRESSION BY CLASS	155
AOE 1 Class	156
AOE 6 Class	157
ARS 50 Class	158
CG 47 Class.....	161
DD 963 Class	163
DDG 51 Class.....	165
FFG 7 Class.....	166
LHA 1 Class	170
LHD 1 Class	172
LPD 4 Class.....	175
LSD 36 Class.....	176
APPENDIX E: SUMMARY OF INDIVIDUAL SHIP REGRESSIONS BY CLASS ..	177
AOE-1 Class.....	178
AOE-6 Class.....	180
ARS Class	183
CVN-68 Class	197
DD-963 Class	201
CG-47 Class	211
FFG Class	221
LHA Class.....	230
LHD Class	232
LPD Class.....	238
LSD-36 Class	243
LSD-41 Class	248
MCM Class	252

MHC Class	257
APPENDIX F: REGRESSIONS TO CALCULATE SUPPLEMENTAL FUNDING REQUIREMENTS.....	259
AOE-1 Class.....	261
AOE-6 Class.....	262
ARS Class	263
CG-47 Class	263
CVN-68 Class	265
DD-963 Class	266
DDG-51 Class	267
FFG Class	269
LHA-1 Class.....	271
LHD Class.....	271
LPD Class.....	273
LSD-36 Class	274
SR	274
LSD-41 Class	275
MCM Class	275
MHC Class	276
APPENDIX G: RECOMMENDATIONS FOR DEVELOPING NEW MODELS	277
APPENDIX H: MAPE COMPARISON TABLES FOR THE MODIFIED MODELS.	281
LIST OF REFERENCES.....	283
INITIAL DISTRIBUTION LIST	285

LIST OF FIGURES

Figure 1: Percentages of the Total Navy Budget for O&M,N and 1B1B.....	2
Figure 2: Ship Ops Model Information Flow Diagram	6
Figure 3: Ship Ops Model FY-CL Constants Sheet	8
Figure 4: Ship Ops Model Inputs for SR, SO and SU	10
Figure 5: Creation of “Prediction from all Actual” (PFAD) Costs.....	22
Figure 6: Development of PFAD Costs	23
Figure 7: Cost Summary for Pacific Fleet DDG-51 Ship Class FY 2002	27
Figure 8: Prediction Analysis of Pacific Fleet DDG-51 Ship Class Fuel Cost for FY 2002	27
Figure 9: Prediction Analysis of Pacific Fleet DDG-51 Ship Class SU, SR and SO Costs for 2002.....	28
Figure 10: Actual Versus PFAD for Pacific Fleet DDG-51 Ships	32

THIS PAGE INTENTIONALLY LEFT BLANK

LIST OF TABLES

Table 1: Ship Ops Model Feeder Sheets.....	7
Table 2: Ship Ops Model Calculation Sheets.....	9
Table 3: Ship Ops Model Summary Sheets.....	11
Table 4: Ship Ops Model Summary Sheets.....	12
Table 5: Prediction Appraisal of Selected Ship Classes' Total Costs.....	29
Table 6: Prediction Analysis of Selected Ship Classes' Fuel Cost.....	30
Table 7: Prediction Appraisal of Selected Ship Classes' Utility Cost.....	31
Table 8: Prediction Analysis of Selected Ship Classes' SR and SO Cost.....	33
Table 9: Example of TYCOM Cost Data.....	35
Table 10: Variables used in Regressions.....	38
Table 11: Best MAPE by Type of Regression SO.....	41
Table 12: Best MAPE by Type of Regression SR.....	42
Table 13: MAPE Comparison for PFAD and the Modified Model SR 2002.....	44
Table 14: MAPE Comparison for PFAD and the Modified Model SR 2001.....	45
Table 15: MAPE Comparison for PFAD and the Modified Model SR 2000.....	46
Table 16: MAPE Comparison for PFAD and the Modified Model SO 2002.....	47
Table 17: MAPE Comparison for PFAD and the Modified Model SO 2001.....	48
Table 18: MAPE Comparison for PFAD and the Modified Model SO 2000.....	49
Table 19: Weighted MAPE Summary.....	50
Table 20: Helpful Definitions of Model Terms and Abbreviations.....	54
Table 21: List of Variables Used in the Regressions in Appendix C.....	122
Table 22: List of Variables Used in Regressions in Appendix D.....	155
Table 23: List of Variables Used in Regressions in Appendix F.....	260
Table 24: Alternative Model Comparison.....	278
Table 25: Weights of Ship Year Unit Costs in Model C.....	279
Table 26: MAPE Comparison for Modified Models SO.....	281
Table 27: MAPE Comparison for Modified Models SR.....	282

THIS PAGE INTENTIONALLY LEFT BLANK

LIST OF ACRONYMS

APPN	Appropriation
BBLs	Barrels
CL	Claimant
CT	Counter Terrorism
CVBG	Carrier Battle Group
DNUW	Deployed Not Underway
DUW	Deployed Underway
FMB	Navy Office of Budget
FY	Fiscal Year
LANTFLT	Atlantic Fleet
LECP	Logistics Engineering Change Proposal
MAPE	Mean Absolute Percentage Error
MTIS	Material Turned Into Stock
NAVSEA	Naval Sea Systems Command
NDNU	Not Deployed Not Underway
NDU	Not Deployed Underway
NEURS	Navy's Energy Usage Reporting System
NSI	No Special Interest
O&M,N	Operations and Maintenance, Navy
O&M,NR	Operations and Maintenance, Navy Reserve
OPCON	Operational Control
OPMONTH	Operating Month
OPNAV	Office of the Chief of Naval Operations
OPTAR	Operating Target
OPTEMPO	Operation Tempo
OSD	Office of the Secretary of Defense
PACFLT	Pacific Fleet

PE	Program Element
PFAD	Predicted From Actual Data
POM	Program Objective Memorandum
RS	Resource Sponsor
SF	Fuel Cost Element
SO	Other Consumable Cost Element
SR	Repair Parts Cost Element
SU	Utilities Cost Element
TAD	Temporary Additional Duty
TYCOM	Type Commander

ACKNOWLEDGEMENTS

We would like to acknowledge the support of LCDR Mike McLean at FMB and the individuals at the various Type Commanders that were ready and willing to support our research by providing data and answering our many questions. We also appreciate the patience and encouragement given by our advisors Professor S.S. Liao and Professor J. E. Mutty. Lastly we would like to thank our families for their understanding and support during this process.

THIS PAGE INTENTIONALLY LEFT BLANK

I. INTRODUCTION

A. BACKGROUND

“We must challenge every assumption and search for new and better ways to accomplish our tasks. We must refine requirements, conduct innovative operations, and optimally allocate resources to achieve efficiencies and recapitalize the Fleet.”

CNO’s 2003 Leadership Guidance

The cost of operating Navy ships is difficult to determine, but extremely important to accurately predict. Under-funding in this area could result in the deferral of equipment replacement and spare parts replenishment/consumption, ultimately reducing the Navy’s current level of readiness. Over-funding could hinder the Navy’s efforts to recapitalize assets in order to meet future threats. As the quote above underscores, the Navy is determined to more accurately predict resource needs in order to fully fund recapitalization efforts.

Within the Operations and Maintenance, Navy (O&M,N) and Operations and Maintenance, Navy Reserve (O&M,NR) appropriations categories, the Mission and Other Ship Operations (1B1B) sub-activity group provides “resources for all aspects of ship operations required to continuously deploy combat ready warships and supporting forces in support of national objectives.” (FY 2003 President’s Budget) The 1B1B sub-activity group, to be referred to as Ship Ops throughout this paper, resource requirements are determined by the OPNAV N80 (programming) staff. The 1B1B program area is divided into five subprograms:

1. Charter
2. Fuel
3. Utilities
4. TAD (Travel and Trainings costs: **Temporary Additional Duty**)
5. OPTAR (**O**perating **T**arget: Includes Repair Parts and Consumables purchases)

The Ship Ops sub-activity group includes the costs within each subprogram for all active and reserve ships. The OPNAV N82 office responsible for this sub-activity, also known as the Office of Budget (FMB), must collect inputs, assess requirements and provide resources as necessary to support the requirements. Figure 1 shows the percentages of the total FY 2004 Navy Budget for O&M, N and Ship Ops.

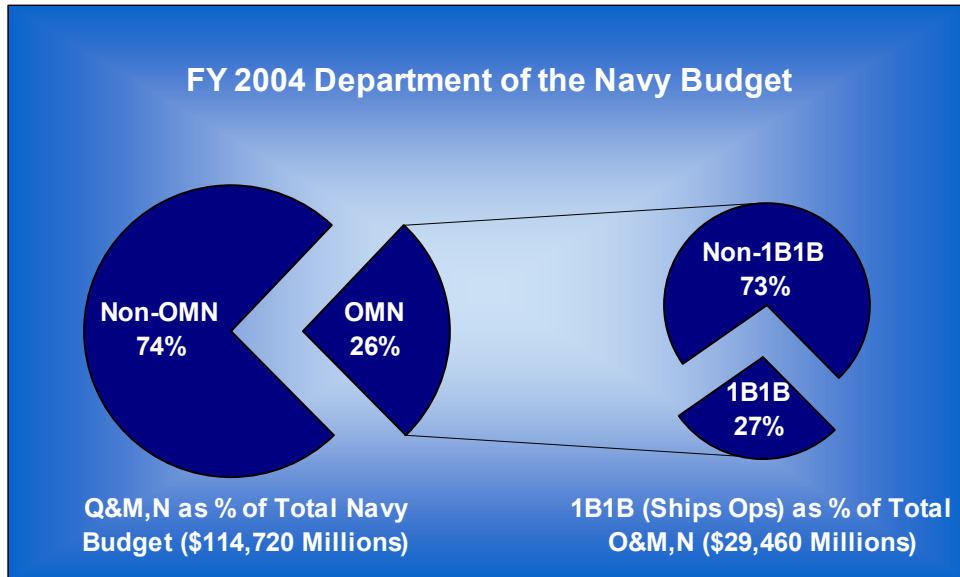

Figure 1: Percentages of the Total Navy Budget for O&M,N and 1B1B

In order to support this sub-activity, N80 must have accurate tools to forecast requirement costs based on fleet inputs. The Ship Operations (Ship Ops) model is used by the OPNAV staff to determine the resource requirements for Ship Ops. The model was developed by the OPNAV N80 (programming) staff several years ago to consolidate inputs from numerous resource sponsors. By consolidating resource sponsor efforts, the model advocates a standardized Navy approach to determining resource requirements for Ship Ops. The existing model uses three-year moving averages and average number of ships in commission to estimate ship-operating costs for the upcoming year.

B. RESEARCH DISCUSSION

FMB feels this model provides a good first estimate of costs, but wants an evaluation of the model as a predictor of actual ship operations costs. FMB has also expressed an interest in the possible development of a more accurate and flexible model. The current model estimates ship costs according to ship class. This model uses a three-year average of previous years' actual operating costs per ship multiplied by the average number of ship years per class. A ship year is defined as a ship in commission for a full year. A ship that is in service for part of a year earns half a ship year no matter what portion of a calendar year it is actually in service.

The model provides FMB with a good first approximation of operating costs for a class of ships. However, FMB feels the model does not provide good information for the effects of increased Operations Tempo (OPTEMPO) in the middle of the year. For instance, if the Abraham Lincoln Carrier Battle Group (CVBG) is extended on deployment, the model is unable to predict the specific additional costs. While, FMB can produce some numbers to estimate additional operating costs, these numbers are not very defensible when requesting increased funding.

C. OBJECTIVES

The intent of this project is to evaluate the current model used by the Office of Budget (FMB) to forecast future operating costs for Navy ships and to develop an improved model if warranted. The strengths and weaknesses of the current model along with input relationships will be identified and analyzed for use in the development of an improved model.

D. ORGANIZATION OF THE PAPER

Chapter II of this paper provides a presentation of the current Ship Ops model including methodology, a description of inputs and outputs, and a description of its use and limitations. Chapter III contains a review of previous studies that have attempted to predict ship operating costs and details the data collected and used to analyze the effective-

ness of the current model. Chapter IV presents the data analysis for the model review including methodology, the results obtained and results validation. Chapter V introduces our proposed modified model and Chapter VI gives recommendations for future research.

II. CURRENT MODEL

A. DESCRIPTION

This chapter provides a narrative description of the current Version 4 of the POM-04 Ship Ops model. It describes model inputs and data flows and provides a list and description of the various model worksheets. To better understand the data manipulation and resulting outputs, Appendix A follows specific data flows and provides example calculations for one ship class in one fleet. It also provides a helpful list of abbreviations and terms used in the various worksheets.

The Ship Ops model is a large Excel file with numerous worksheets linking execution data inputs to cost projection outputs. These worksheets can be grouped into four categories: Feeder Sheets, Calculation Sheets, Summary Sheets and Info Sheets. Because Info Sheets simply provide additional information about the model (e.g.: the modifications made from previous versions) and Summary Sheets merely display and manipulate data from other sheets for presentation purposes, they are irrelevant to our discussion of cost estimation.

The basic flow of data is shown below:

Basic Input → Feeder Sheets → Calculation Sheets → Summary Sheets

The Basic Input from various sponsors is provided to the multiple Feeder Sheets. Feeder Sheets are used to enter data into the model. The basic input data include execution data, escalation rates, fuel prices and underway and deployment status inputs. The calculation sheets, which are linked both to the Feeder Sheets and the Summary Sheets, manipulate these inputs and display the results in the Summary Sheets. Figure 2 is a modified diagram from the 2001 Ship Ops Model User's Guide of the model's data flow for the POM-04 version 4 model.

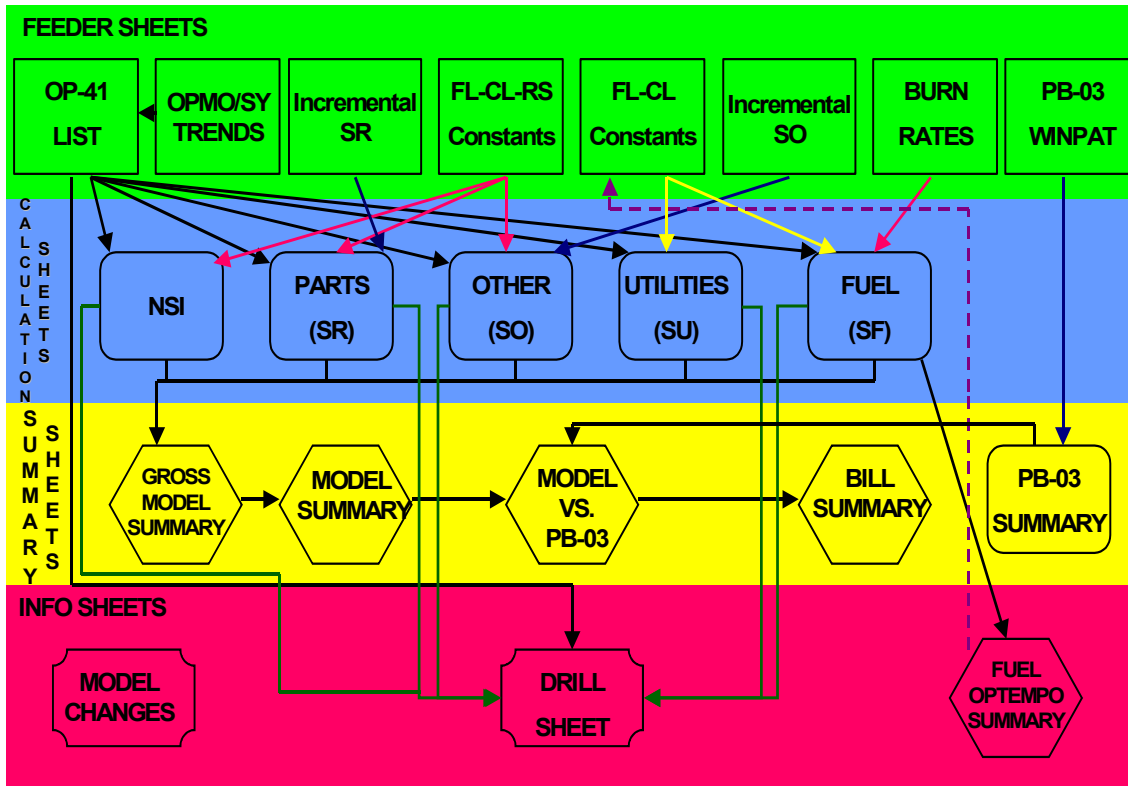

Figure 2: Ship Ops Model Information Flow Diagram

1. Feeder Sheets

In the version of the model that we used for our analysis there are six Feeder Sheets. Table 1 lists the different feeder sheets with a brief description of the basic input contained in each.

Feeder Sheet	Contents
OP-41 List	The model's main source of execution data. Execution data for SR, SO, SU, and NSI are fed into this sheet to calculate the future requirements based on projected ship years and operating months.
FY-CL Constants	Contains the constants for FY (fiscal year) and CL (claimant). These include days per month, price per barrel, and multipliers based on ship status (Deployed or Non-deployed and Underway or not Underway). It also has price growths and factors for the other fund codes.
FY-CL-RS Constants	Contains constants that vary by resource sponsor (RS).
Incremental SO	Contains one year or multi-year special requirements based on program element (PE), FY and CL. Note: There can be Incremental sheets for each fund code.
Incremental SR	Same as Incremental SO
Burn Rates	Provides most of the input for the Fuel (SF) worksheet. Includes deployed and non-deployed input for days underway per month, days not underway per month, underway burn rates and not underway burn rates

Table 1: Ship Ops Model Feeder Sheets

The primary inputs are the execution data and historical cost data. These inputs are updated in the OP-41 List Feeder Sheet. The numbers are submitted by the Type Commanders and reviewed by the resource sponsors. Execution data consist of operational month and ship years¹, which are based on historical data that include the previous three years, and predicted inputs for the future years. For example, the 2002 version of the model contains actual (historical) information from FY 1999 through 2001. The rest of the execution data (years 2002 till 2009) are estimated by the Fleets and are used for determining future requirements. Cost data for each fund category are entered using actual figures from the previous three years.

Other inputs contained in the Feeder Sheets include various multipliers which are used for adjusting the “raw data” to meet requirements. The FY-CL Constants Feeder

¹ Operational month for this model is defined as the sum of months deployed and months non-deployed. A ship year is based on a ship's operational status, if the ship is commissioned, newly commissioned, or de-commissioned.

Sheet, shown below in Figure 3, has the multipliers that are applicable regardless of resource sponsors and are constant in a fiscal year (FY) and Fleet Claimant (CL). Here the user can enter the price of fuel per barrel based on the data provided by the Office of the Secretary of Defense (OSD), and also can use the OPTEMPO multiplier to adjust total OPTEMPO figures to meet predicted requirements. These two columns are used in the fuel cost calculation. The constants that change from one resource sponsor to the other are incorporated in the FY-CL-RS Constants Feeder Sheet. This sheet provides the price growth input for SR and SO among others.

	A	B	C	D	E	F	G	H	I	J	K	L	M	N	O	P	Q	R	S	
1	FY-CL-OMN	FY	C	DAYS per Month	Deployed Price per BB	D-not UV/IMO Factor	Non-Deployed Price per BB	D-not UV/IMO Factor	OPTAR Control	Utilities Price Growth	Repair Parts Gold Disk/REP	100% ICAS Reductio	OPTAR PDRE P	NSI	OMN-OMNR					
43	2002-60-OMN	###	60	30.4	100675	\$40.32	0.900	1.0009	\$40.32	0.900	100.0%	102.50%	100.0%	95.00%		157%	66.67%	10000	0.0000	OMN
44	2002-60-OMNR	###	60	30.4	0.93750	\$40.32	0.900	1.3930	\$40.32	0.900	100.8%	102.40%	89.0%	0.00%	157%	66.67%	10000	0.0000	OMNR	
45	2002-60-OMNRMHC	###	60	30.4	106061	\$40.32	0.900	1.9444	\$40.32	0.900	100.0%	102.46%	100.0%	95.00%	157%	66.67%	10000	0.0000	OMNRMHC	
46	2002-60-OMNRICV	###	60	30.4	175000	\$40.32	0.900	0.7660	\$40.32	0.900	100.0%	102.46%	100.0%	95.00%	157%	66.67%	10000	0.0000	OMNRICV	
47	2002-60-OMNRMCS	###	60	30.4	183404	\$40.32	0.900	1.831	\$40.32	0.900	100.0%	102.46%	100.0%	95.00%	157%	66.67%	10000	0.0000	OMNRMCS	
48	2002-70-OMN	###	70	30.4	0.98339	\$40.32	0.900	0.9982	\$40.32	0.900	100.0%	132.60%	100.0%	95.00%	157%	66.67%	10000	0.0000	OMN	
49	2002-70-OMNR	###	70	30.4	0.45307	\$40.32	0.900	0.9594	\$40.32	0.900	100.0%	133.00%	100.0%	95.00%	157%	66.67%	10000	0.0000	OMNR	
50	2003-60-OMN	###	60	30.4	100672	\$34.02	0.993	1.0096	\$34.02	0.900	100.0%	99.00%	100.0%	95.00%	0.00%	66.67%	10000	0.0000	OMN	
51	2003-60-OMNR	###	60	30.4	0.93750	\$34.02	0.900	1.3930	\$34.02	0.900	102.2%	99.30%	107.0%	95.00%	0.00%	66.67%	10000	0.0000	OMNR	
52	2003-60-OMNRMHC	###	60	30.4	106061	\$34.02	0.900	1.9444	\$34.02	0.900	100.0%	97.96%	100.0%	95.00%	0.00%	66.67%	10000	0.0000	OMNRMHC	
53	2003-60-OMNRICV	###	60	30.4	0.95000	\$34.02	0.900	0.7700	\$34.02	0.900	100.0%	97.96%	100.0%	95.00%	0.00%	66.67%	10000	0.0000	OMNRICV	
54	2003-60-OMNRMCS	###	60	30.4	2.66667	\$34.02	0.900	1.8667	\$34.02	0.900	100.0%	97.96%	100.0%	95.00%	0.00%	66.67%	10000	0.0000	OMNRMCS	
55	2003-70-OMN	###	70	30.4	0.98805	\$34.02	0.900	1.0007	\$34.02	0.900	100.0%	103.90%	100.0%	95.00%	0.00%	66.67%	10000	0.0000	OMN	
56	2003-70-OMNR	###	70	30.4	0.45307	\$34.02	0.900	0.6383	\$34.02	0.900	100.0%	95.80%	100.0%	95.00%	0.00%	66.67%	10000	0.0000	OMNR	
57	2004-60-OMN	###	60	30.5	0.99986	\$34.02	0.900	0.9940	\$34.02	0.900	100.0%	110.60%	100.0%	95.00%	0.00%	66.67%	10000	0.0000	OMN	
58	2004-60-OMNR	###	60	30.5	2.66667	\$34.02	0.900	1.3930	\$34.02	0.900	101.8%	109.70%	101.8%	95.00%	0.00%	66.67%	10000	0.0000	OMNR	
59	2004-60-OMNRMHC	###	60	30.5	106061	\$34.02	0.900	1.9444	\$34.02	0.900	100.0%	101.80%	100.0%	95.00%	0.00%	66.67%	10000	0.0000	OMNRMHC	
60	2004-60-OMNRICV	###	60	30.5	0.95000	\$34.02	0.900	0.7600	\$34.02	0.900	100.0%	101.80%	100.0%	95.00%	0.00%	66.67%	10000	0.0000	OMNRICV	
61	2004-60-OMNRMCS	###	60	30.5	2.66667	\$34.02	0.900	1.8667	\$34.02	0.900	100.0%	101.80%	100.0%	95.00%	0.00%	66.67%	10000	0.0000	OMNRMCS	
62	2004-70-OMN	###	70	30.5	0.98325	\$34.02	0.900	0.9998	\$34.02	0.900	100.0%	82.90%	100.0%	95.00%	0.00%	66.67%	10000	0.0000	OMN	
63	2004-70-OMNR	###	70	30.5	0.45307	\$34.02	0.900	0.6383	\$34.02	0.888	100.0%	101.80%	100.0%	95.00%	0.00%	66.67%	10000	0.0000	OMNR	
64	2005-60-OMN	###	60	30.4	100633	\$34.44	0.900	1.0085	\$34.44	0.900	100.0%	101.70%	100.0%	95.00%	0.00%	66.67%	10000	0.0000	OMN	
65	2005-60-OMNR	###	60	30.4	0.93750	\$34.44	0.900	1.3930	\$34.44	0.900	101.8%	101.70%	101.8%	95.00%	0.00%	66.67%	10000	0.0000	OMNR	
66	2005-60-OMNRMHC	###	60	30.4	106061	\$34.44	0.900	1.9444	\$34.44	0.900	100.0%	101.80%	100.0%	95.00%	0.00%	66.67%	10000	0.0000	OMNRMHC	
67	2005-60-OMNRICV	###	60	30.4	170000	\$34.44	0.900	0.7670	\$34.44	0.900	100.0%	101.80%	100.0%	95.00%	0.00%	66.67%	10000	0.0000	OMNRICV	
68	2005-60-OMNRMCS	###	60	30.4	2.66667	\$34.44	0.900	1.8667	\$34.44	0.900	100.0%	101.80%	100.0%	95.00%	0.00%	66.67%	10000	0.0000	OMNRMCS	
69	2005-70-OMN	###	70	30.4	0.98944	\$34.44	0.900	1.0020	\$34.44	0.900	100.0%	101.70%	100.0%	95.00%	0.00%	66.67%	10000	0.0000	OMN	
70	2005-70-OMNR	###	70	30.4	0.45307	\$34.44	0.900	0.9929	\$34.44	0.900	100.0%	101.80%	100.0%	95.00%	0.00%	66.67%	10000	0.0000	OMNR	
71	2006-60-OMN	###	60	30.4	1.01182	\$35.24	0.900	1.0118	\$35.24	0.900	100.0%	101.90%	100.0%	95.00%	0.00%	66.67%	10000	0.0000	OMN	
72	2006-60-OMNR	###	60	30.4	0.93750	\$35.24	0.900	1.3930	\$35.24	0.900	101.9%	101.90%	101.9%	95.00%	0.00%	66.67%	10000	0.0000	OMNR	
73	2006-60-OMNRMHC	###	60	30.4	106061	\$35.24	0.900	1.9444	\$35.24	0.900	100.0%	101.90%	100.0%	95.00%	0.00%	66.67%	10000	0.0000	OMNRMHC	
74	2006-60-OMNRICV	###	60	30.4	170000	\$35.24	0.900	0.7670	\$35.24	0.900	100.0%	101.90%	100.0%	95.00%	0.00%	66.67%	10000	0.0000	OMNRICV	
75	2006-60-OMNRMCS	###	60	30.4	2.66667	\$35.24	0.900	1.8667	\$35.24	0.900	100.0%	101.90%	100.0%	95.00%	0.00%	66.67%	10000	0.0000	OMNRMCS	
76	2006-70-OMN	###	70	30.4	0.98438	\$35.24	0.900	1.0005	\$35.24	0.900	100.0%	101.90%	100.0%	95.00%	0.00%	66.67%	10000	0.0000	OMN	
77	2006-70-OMNR	###	70	30.4	0.45307	\$35.24	0.900	0.9929	\$35.24	0.900	100.0%	101.90%	100.0%	95.00%	0.00%	66.67%	10000	0.0000	OMNR	
78	2007-60-OMN	###	60	30.4	100353	\$36.05	0.900	1.0102	\$36.05	0.900	100.0%	101.90%	100.0%	95.00%	0.00%	66.67%	10000	0.0000	OMN	
79	2007-60-OMNR	###	60	30.4	0.93750	\$36.05	0.900	1.3930	\$36.05	0.900	101.9%	101.90%	101.9%	95.00%	0.00%	66.67%	10000	0.0000	OMNR	
80	2007-60-OMNRMHC	###	60	30.4	106061	\$36.05	0.900	1.9444	\$36.05	0.900	100.0%	101.90%	100.0%	95.00%	0.00%	66.67%	10000	0.0000	OMNRMHC	
81	2007-60-OMNRICV	###	60	30.4	170000	\$36.05	0.900	0.7670	\$36.05	0.900	100.0%	101.90%	100.0%	95.00%	0.00%	66.67%	10000	0.0000	OMNRICV	
82	2007-60-OMNRMCS	###	60	30.4	2.66667	\$36.05	0.900	1.8667	\$36.05	0.900	100.0%	101.90%	100.0%	95.00%	0.00%	66.67%	10000	0.0000	OMNRMCS	
83	2007-70-OMN	###	70	30.4	0.98733	\$36.05	0.900	1.0012	\$36.05	0.900	100.0%	101.90%	100.0%	95.00%	0.00%	66.67%	10000	0.0000	OMN	
84	2007-70-OMNR	###	70	30.4	0.45307	\$36.05	0.900	0.9929	\$36.05	0.900	100.0%	101.90%	100.0%	95.00%	0.00%	66.67%	10000	0.0000	OMNR	
85	2008-60-OMN	###	60	30.5	0.99808	\$36.87	0.900	1.0091	\$36.87	0.900	100.0%	101.90%	100.0%	95.00%	0.00%	66.67%	10000	0.0000	OMN	
86	2008-60-OMNR	###	60	30.5	1.00000	\$36.87	0.900	1.3930	\$36.87	0.900	101.9%	101.90%	101.9%	95.00%	0.00%	66.67%	10000	0.0000	OMNR	

Figure 3: Ship Ops Model FY-CL Constants Sheet

The final category of inputs consists of the “normative” data. Primarily these data include standards for burn rate calculations (fuel usage based on a ship’s operational status) for deployed and non-deployed ships and standards for OPTEMPO (depending on current CNO goals) that set the standards for underway days for deployed and non-deployed ships. These are not included in the Constants Feeder Sheets.

2. Calculation Sheets

There are currently six Calculation Sheets that provide projected costs for Repair Parts (SR), Other Consumables (SO), Utilities (SU) and Fuel (SF), No Special Interest (NSI), for non-standard yearly requirements, and Counter Terrorism (CT). These costs are calculated separately in the Calculation Sheets and then aggregated in the Summary Sheets. Table 2 lists and describes each Calculation Sheet.

Calculation Sheet	Description
No Special Interest (NSI)	Calculated using input from various feeder worksheets. Baseline is average of the last three years of execution data plus price growth factors.
Repair Parts (SR)	Same as NSI but is adjusted with input from savings initiatives.
OPTAR Other (SO)	Same as NSI
Utilities (SU)	Baseline is the last three years’ SU per OP month average. The SU requirement is adjusted for price growth and multiplied by the projected number of op months.
Fuel (SF)	Most complex of the calculation sheets. Includes two main sections for deployed and non deployed status. These are further divided into underway and not underway. Each section determines the total number of barrels of fuel required.
Counter Terrorism (CT)	Same as NSI.

Table 2: Ship Ops Model Calculation Sheets

The fundamental methodology of the cost calculation entails using a three-year moving average of the unit cost (cost/ship years in case of SR and SO, and cost/OPMONTHs in case of SU) of the specific cost element. For example the cost assessment for FY2003 is computed by taking the average unit cost from FY2000 through FY2002 (total cost/total ship years), corrected with the *actual* price growths to get an average unit cost in year 2002 dollars. This value is then multiplied by the *predicted* price growth factor from FY2002 to FY2003 and multiplied by the estimated value of ship years for FY2003. The result will be the base requirement for that year. This base value will be adjusted with the value of estimated savings (where applicable). The adjusted value is the cost estimate for FY2003. Figure 4 shows the diverse types of inputs that are used for SR, SO and SU cost predictions. Notice the different estimated figures established for predicting future cost. We will use this structure to explain our methodology in Chapter IV.

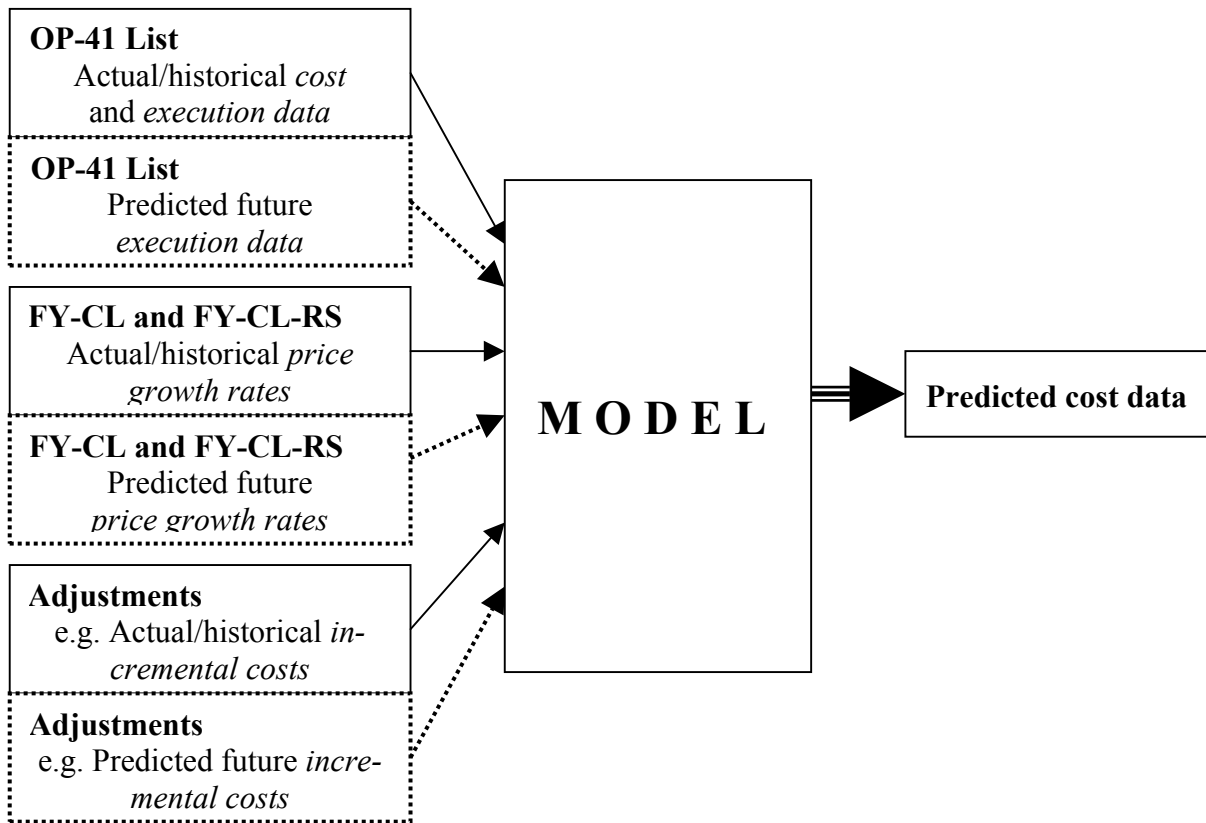

Figure 4: Ship Ops Model Inputs for SR, SO and SU

The calculation of SF differs significantly from the other three cost types, since it uses burn rates based on the standard number of days underway in a deployed or in a non-deployed status. The number of days underway depends on the ship’s operational status based on one of five categories. The five operational categories are deployed underway, deployed not underway, not deployed underway, not deployed not underway and repair days. Then using the burn rate norms (calculated from historical consumption data of the NUERS database), multiplied by the predicted/established fuel price one gets fuel cost in each categories, which comprise the total predicted SF expenses.²

3. Info Sheets

The model also has three explanatory info sheets. There are two “drill” type sheets that allow the user to run “what if” drills without affecting the other worksheets and the other details the list of model changes by version. Table 3 below lists each sheet and provides a brief description.

Info Sheet	Description
Drill Worksheet	Provides cost per year data on the current model. These data assist resource sponsors with what if drills
Fuel OPTEMPO Summary	Used to set the OPTEMPO goals by changing the OP-TEMPO multiplier
Model Changes	Provides description of each model change and update

Table 3: Ship Ops Model Summary Sheets

² NEURS is the Navy’s Energy Usage Reporting System. In the NEURS system, ships are required to submit monthly reports listing the amount of fuel used, hours underway, hours cold iron and several other factors detailed in OPNAV INSTRUCTION 4100.11B.

4. Summary Sheets

The model output detailed in the Summary Sheets is based on ship class. Cost projection results are made for ship classes and not for an individual ship. The output can be further grouped by fleet, resource sponsor, program element and fiscal year. The current version of the model contains cost estimates through FY 2009.

The outputs of the Ship Ops model are contained in the nine Summary Sheets that are fed by the calculation sheets. These sheets summarize the output of the model and help provide comparisons for previous FY's. The lowest output level is by ship type. Table 4 provides the title and a brief description of each sheet.

Name	Description
Model Summary	Provides a summary by PE of the model's current calculation. Provides resource sponsor and claimant totals.
Gross Model Summary	Summarizes the model calculation by ship type and feeds the Model Summary sheet
Model vs. PB-03 Summary	Shows delta between PR-03 database and the model.
PB-03 Summary	Shows the PB-03 data in the Model Summary format.
PB-03 WINPAT	Shows the PB-03 data from a raw WINPAT run. Feeds the PB-03 Summary sheet.
Bill Summary	Summarizes element costs by resource sponsor.

Table 4: Ship Ops Model Summary Sheets

B. USE AND LIMITATIONS

The model provides FMB with a summary of predictive costs to be used for resource requests. The model has been in use for about five years and there has not been a detailed comparison of actual costs to predicted costs. The obvious limitations of the model are scalability and flexibility. The summary output provided by this model can only be reduced, at the lowest level, by ship class and sponsor. The user cannot easily input proposed operational adjustments to multiple ships to see the predictive effects on

cost, especially in case of SR and SO, since they are predicted purely based on ship years and numbers in the class of ships.

Another limitation of the model is its reliance on the outputs using a three-year moving average of unit costs. This method provides a simple means for making cost predictions and also can rapidly incorporate the effects of the current environment. Drawbacks to its use in the model are that the third year's data are an estimate and that one-year can have a significant impact in the units output (while planning year 2003's costs, the programmer only had preliminary cost data for 2002 based on the past 6-9 months from the current fiscal year, which is better than a simple prediction, but still not actual cost).

Before analyzing the effectiveness of the model by comparing actual with predicted operating costs, Chapter III will review other studies that have attempted to find methods for ship cost prediction. This chapter will also detail the data that will be used to compare actual costs with those that were predicted by the current Ship Ops model.

THIS PAGE INTENTIONALLY LEFT BLANK

III. DATA COLLECTION

A. REVIEW OF PREVIOUS STUDIES

There has not been a previous study that has attempted to analyze the effectiveness of the Ship Operating Model to predict operating costs. However, there have been numerous studies that have attempted to identify drivers that can be used to accurately predict various costs associated with operating ships.

In 1987, Williams used parametric and non-parametric statistical methods to determine the dependency of obligation patterns on operating schedules. The study used two years of operating and OPTAR data from the FF-1052 and CG-27 ship classes. The study could not find a significant relationship between obligation patterns and operating schedules. In 1988, Kuker and Hansen also attempted to relate ship OPTAR obligation patterns to their operating schedules. Using the same ship classes as Williams, they used judgmental and mathematical forecasting models along with multiple regressions to identify relevant cost relationships. The study identified patterns in the OPTAR obligation data that could be attributed to the ship's employment schedule. (Kuker and Hansen, 63). These relationships were used to develop forecasting models that did not work well on an individual ship level but could have some use at a ship class level.

In 1993, Ting attempted to develop operating and support (O&S) cost models for ships by examining manpower, material, maintenance and overhaul costs. The study found that cost relationships between factors other than overhauls were strong. Manpower was found to have the most dramatic effect on predicting O&S costs. (Ting, 59)

In 1998, Catalano attempted to develop an OPTAR allocation model for Pacific Fleet surface ships. Using repair part costs as a dependent variable for each individual ship, the study used the number of months before overhaul, number of months on deployment and if the ship was in a pre-deployment quarter as explanatory variables. The study found mostly insignificant constants and very low R-squares.

Brandt in 1999 used regression analysis to develop a parametric cost model for estimating O&S costs for non-nuclear ships. He used ship displacement, ship length and ship manpower as independent variables to estimate average overall O&S costs. The

study concluded that there is a constant mean of O&S costs for a ship class and that the age of the ship did not have a positive influence on O&S costs as expected.

Given the findings of previous work, our project identifies relationships between repair parts cost (SR) and operational activity. We have also identified a relationship between OPTAR/other cost (SO) and operational activity of surface ships. We have incorporated these relationships into a new ship ops model. In order to establish these relationships we used the following data.

B. COST DATA

Cost data were used in this project for two purposes: first, to evaluate the Ship Ops model's predictive capabilities and second to build a modified model and compare its predictions to that of the existing model. We used various versions of the current model – which were provided by FMB – to gather historical cost data for the appraisal part of our work. The Atlantic and Pacific Fleets, and multiple Type Commanders (TY-COMs) provided the information for the modified model.

However, we had certain qualitative and quantitative reservations regarding the data. The qualitative problem surfaced when we were assessing the current model's accuracy. It appeared we were not looking at the “first estimates” provided by the Ship Ops model (by first estimate we are referring to the predictions that were produced for the purposes of the initial budgeting). Some of the inputs (e.g.: price growth) might have been updated during the fiscal year in order to get more accurate results. The benefit from doing this is that more accurate estimates can support the argument for additional funding when the need arises. Though our analysis uses only actual data, our conclusion could be slightly or significantly different if we compared the “first estimates” to the actual cost figures. Our methodology chosen for the analysis – separating the effects caused by the model's discrepancies and effects stemming from input inaccuracy – ensures that the basic evaluation remains the same regardless of whether we used the “first estimates” or not. The problem resulting from using the updated predictions is that the difference caused by the unreliable inputs may be more significant than we indicated.

Quantitative problems were mainly caused by the problem of data availability. We faced this problem during the process of building the modified model. Since we used various sources, the historical cost data were not always available for the same years. The Navy Energy Usage Reporting System (NEURS) data (days underway while under various Operational Controls (OPCON)) provided by LANTFLT is only available back through FY 96. NEURS data provided by PACFLT goes back through FY 92. Cost data, contained in the models provided by FMB, are only available back through FY 94. This means that we had to find the lowest common denominator, that is, incorporating only those fiscal years into the project where “all” the data were accessible.

When conducting our initial regression analysis it became evident that regressions that did not include price growth factors were more significant than those that did include them. This raised suspicion concerning the validity of the inflation factors used in the model. Further investigation by FMB concluded that the Inflation Category Codes, which are assigned by the TYCOMs, in order to obtain a weighted average inflation factor to be used in the model, were not properly assigned. Therefore, through consultation with FMB, we have concluded it is more relevant to exclude inflation factors - as an independent variable - in regressions used in formulation of a modified model.

The original tasking from FMB was to analyze the model with particular emphasis on SR and SO. While we include some analysis of the remaining components of the model, we have limited our efforts in improving the model to these two Special Interest Items.

C. EMPLOYMENT DATA

In order to determine the number of days a given ship (or in aggregate, a ship class) was underway during a given year, we obtained data from the NEURS database. NEURS is a program the Navy uses to monitor days underway for all surface ships (It primarily records the amounts of fuel used. For our purposes, days underway is the most relevant information). Because the reports submitted by the ships are classified by OPCON, we were able to determine if a ship was underway while on deployment, underway while not on deployment or even if the ship was underway while deployed in the Fifth

Fleet. With these data we are better able to dissect the employment of ships. For example, if a ship was underway for a total of 100 days in a year, we were able to determine that 50 days were underway not deployed, 30 days were underway deployed and 20 days were underway in the Fifth Fleet. When performing analysis by ship class, the information used was days underway while deployed (aggregation of all deployed OPCONs) and days underway while not deployed. Because of the limited data points available for analysis we were unable to use the additional variable (Deployed to Fifth Fleet) without sacrificing the statistical accuracy of the regressions.

D. SHIP CLASSES CHOSEN

For our analysis of the current model, we chose to use the Pacific Fleet DDG-51 class, because of the amount of the data available. It is a large class and it represents the growth of the fleet. An example is contained in Appendix A. In Chapter IV, we use five ship classes FFG-7, DDG-51, CG-47, DD-963, and LHA-1 to give an overview of the model’s accuracy at the ship class level for the period FY97 through FY02. These classes provide a broad representation of the surface fleet. DDG-51 represents a class experiencing growth while FFG-7 and DD-963 are classes experiencing contraction. LHA-1 and CG – 47 are ship classes, that remain stable in numbers throughout the period analyzed.

In our regression analysis, we were limited in the ship classes we were able to study. For example, we were unable to obtain submarine employment data from Naval Sea Systems Command (NAVSEA 08). NAVSEA 08 does not track days underway. They maintain information similar to NEURS, but instead of days underway tracks Effective Full Power Hours for reimbursement to DOE. We performed regression analysis on the following 15 classes of ships that we had all operations data on:

AOE-1	AOE-6	MCM-1	MHC-51	LHA-1
LHD-1	LPD-4	LSD-36	LSD-41	CG-47
DDG-51	DD-963	FFG-7	ARS-50	CVN-68

Table 5: Ship Classes Used in Regression Analysis

Chapter IV analyzes the effectiveness of the model by comparing actual with predicted operating costs. Before presenting our results, this chapter details our methodology and analysis application.

THIS PAGE INTENTIONALLY LEFT BLANK

IV. DATA ANALYSIS

A. METHODOLOGY

In this section we will discuss the methodology for evaluating the Ship Ops model. Figure 4 in Chapter 2, depicts the different kinds of data input from which the model predicts a certain year's O&M,N costs. Generally, the model creates an average unit cost (per ship year or per OPMONTH), and then uses *estimated* execution data to generate the predicted basic requirement for the next year. This basic requirement is then adjusted by the *estimated* price growth (percentage growth or decrease) and/or by the *estimated* incremental cost in order to get the adjusted requirement for the given year.³

To filter the inaccuracies of the estimated operational and financial inputs, we created "*predicted from all actual data*" (PFAD) costs for ex-post prediction. Figure 5 shows the structure of the inputs used in the model to produce these quasi-predicted numbers. Note the difference between Figure 4 (Chapter 2) and Figure 5. The PFAD costs demonstrate what would have happened if all the inputs had been absolutely precise.

³ Incremental costs are one time costs such as replacing foam mattresses with spring mattresses. Incremental costs can be determined and used by the RS or CL for each cost element.

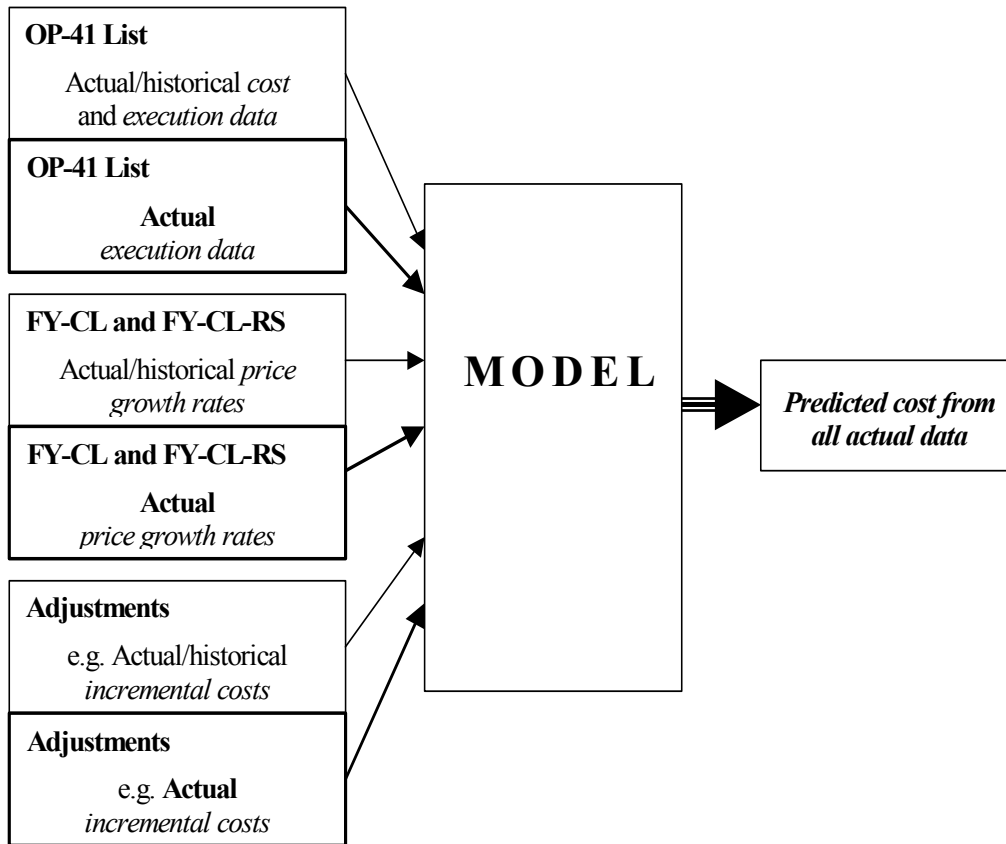

Figure 5: Creation of “Prediction from all Actual” (PFAD) Costs

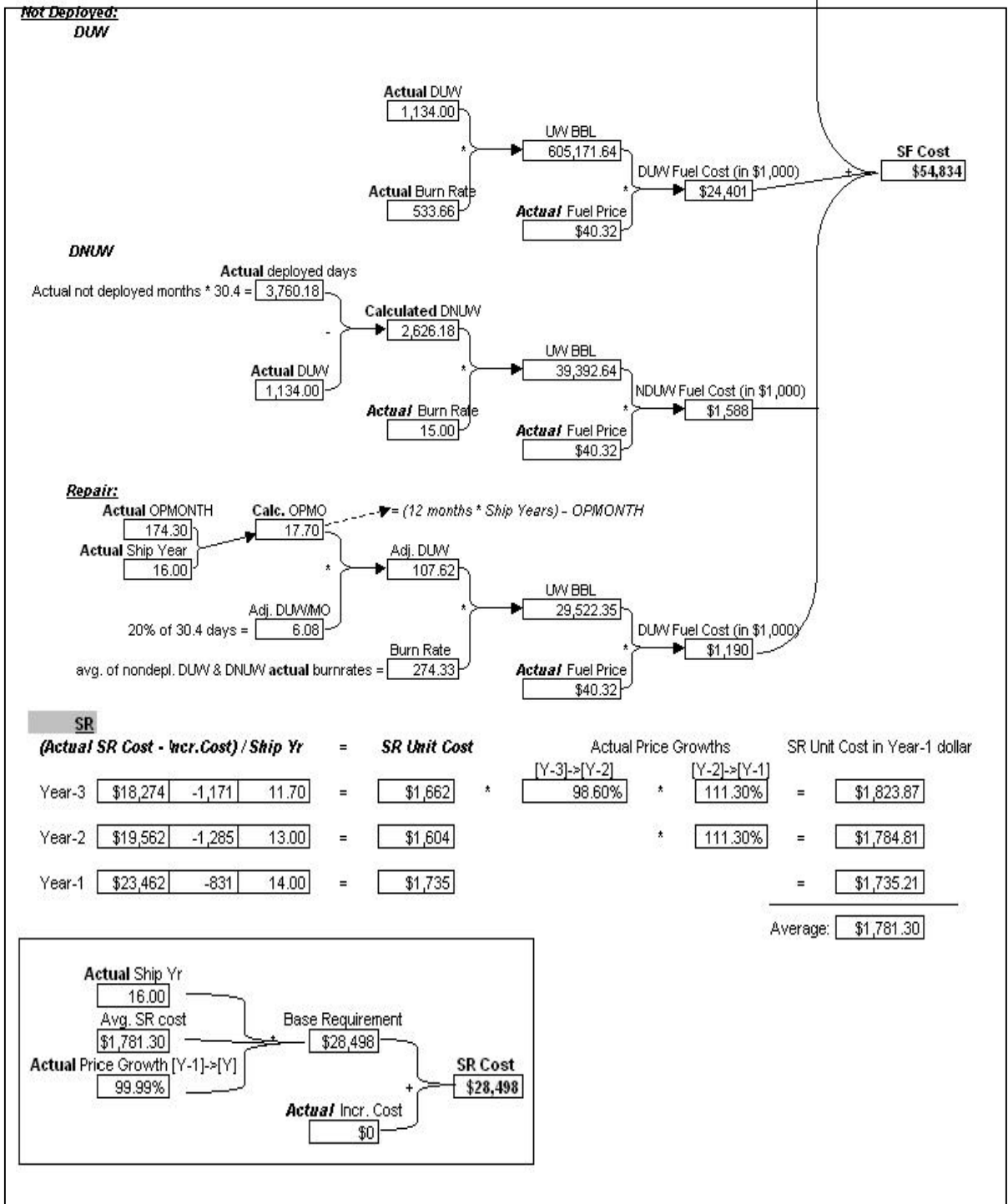

Figure 6: Development of PFAD Costs

Including the actual cost data, we have three numbers for comparison for each cost element: actual, predicted and PFAD. The model's total inaccuracy can be calculated by subtracting the predicted cost from the actual:

$$\text{Model's total inaccuracy} = \text{Actual cost} - \text{Predicted cost}$$

In this way we get the difference between budgeted (predicted) and incurred (actual) costs, which is our focus. However, by using the quasi-predicted PFAD costs, we can decompose this difference into its two main components.

First, by obtaining the difference between PFAD and the predicted costs, we determine the effect of data inaccuracy from the budgeting process:

$$\text{Effect of source data inaccuracy} = \text{PFAD} - \text{Predicted cost}$$

The second component can be calculated by determining the disparity of the PFAD and the actual cost figures. This difference gives us important information about the model's predictive ability without the noise caused by imprecise inputs.

$$\text{Effect of the model's method} = \text{Actual cost} - \text{PFAD}$$

Summing the component effects determines the model's total inaccuracy:

$$\text{Effect of source data inaccuracy} + \text{Effect of the model's method} = (\text{PFAD cost} - \text{Predicted cost}) + (\text{Actual cost} - \text{PFAD cost}) = \text{Actual cost} - \text{Predicted cost} = \text{Model's total inaccuracy}$$

As we will see in the Results section of this chapter, these two component effects sometimes occur in the same direction (i.e., both underestimate or both overestimate) and combine to increase the total difference. Other times they have opposite effects, resulting in a smaller total difference than would be observed by summing the absolute values of the component effects.

This decomposition method sheds light on problems that are hidden from the observer who only takes into account the total inaccuracy of the model. However, due to the natural variation of actual costs, improving either the accuracy of the source data or the model's predictive ability, will not guarantee improvement in all cases.

B. APPLICATION

Our project focuses on improving the model's method (reducing the second component effect), but we will discuss some input precision (first component) issues. In the second part of the Results section, we use hypothesis testing and the Mean Absolute Percentage Error (MAPE) to examine the difference between the PFAD and actual costs.

1. Hypothesis Test

For our analysis, we want to see if the differences between actual numbers and model predictions are in effect random deviation, or if the differences are statistically significant and a pattern exists in these differences. The null hypothesis is: the mean of the differences (Actual – PFAD) is zero; while the alternative hypothesis is that it is not zero:

$$H_0: \mu = 0$$

$$H_1: \mu \neq 0$$

where μ is the real mean that we do not know, but estimate as \bar{X} . We selected the percentage error as the basic unit for the test, since it is comparable across ship classes as well as years. We calculated p-values for determining the probability of making a Type I

error ⁴ (rejecting the null hypothesis when actually it's true). The p-value is derived from the t-statistic, calculated the following way:

$$t - value = \frac{\bar{X} - \mu}{s / \sqrt{n}}$$

where s is the sample standard deviation, and n is sample size.

The p-value is then determined by using a t-distribution table (degrees of freedom equals $n-1$) and the assumption of a two-tailed test since we are interested in probable differences on both ends of the distribution (positive or negative). From the obtained p-value, we can either reject the null hypothesis (which implies that the mean of the differences is not zero, so the model estimates values inaccurately) or accept the null hypothesis (which produces an overall good prediction or insufficient evidence of the opposite).

2. Mean Absolute Percentage Error (MAPE)

The second method, the MAPE, is more frequently used for evaluating the accuracy of forecasting models. It is the average of the prediction's absolute percentage error. It has an advantage of using absolute values for comparison, which eliminates the offsetting effect of opposing (positive and negative) component differences. The MAPE is an absolute value, which can be objectively applied for comparing the relative strength of different forecasting models. But its disadvantage comes from the fact it is a subjective measure when used without a benchmark for comparison.

C. RESULTS

After looking through an example of a single ship class for FY 2002 in this section, we will discuss the overall evaluation of the model. The detailed results of comparisons for all ship classes can be found in Appendix B.

To demonstrate our evaluation of the model we will analyze the Pacific Fleet DDG-51 ship class for FY 2002. Excluding CT and NSI costs, the model predicts the total O&M,N cost fairly well (see Figure 7). The model overestimated the costs by approximately \$17.7 million (\$113.1M - \$95.4M), which is an 18.6% inaccuracy relative to

⁴ Albright, Winston, Zappe; Data Analysis & Decision Making with Microsoft Excel; Duxbury Press, 2002; p. 441.

the actual cost. The component effects are similar, as most of the cost elements exceeded the estimated values.

	SF	SU	SR	SO	Total	
Actual	\$47,841	\$12,553	\$23,849	\$11,147	\$95,390	
Predicted	\$58,175	\$11,612	\$27,410	\$15,931	\$113,128	
Predicted from All Actual Data	\$54,834	\$11,251	\$28,498	\$15,660	\$110,242	
Actual - Predicted	-\$10,334	\$941	-\$3,561	-\$4,784	-\$17,738	-18.60% -> model total inaccuracy
- Pred. fr Actual - Predicted	-\$3,342	-\$361	\$1,088	-\$271	-\$2,886	-3.03% -> source data inaccuracy
- Actual - Pred. Fr Actual	-\$6,993	\$1,302	-\$4,649	-\$4,513	-\$14,852	-15.57% -> model inaccuracy

Figure 7: Cost Summary for Pacific Fleet DDG-51 Ship Class FY 2002

SF, which has the largest weight in O&M,N costs (in this case 50.2%), was estimated with a fair result (see Figure 8, 21.6% difference between the predicted and actual costs).

SF	value	Full effect	Part effect	Weight	
Actual	\$47,841			50.15%	
Predicted	\$58,175	-\$10,334	-\$3,342	-6.98%	
Predicted from All Actual Data	\$54,834	-\$6,993	-\$4,513	-14.62%	
- Predicted w/ actual DUWs	\$52,880		-\$5,039	-10.53%	Predicted 2,402 vs. Actual 2,170 -10.70%
- Predicted w/ actual Burn Rates	\$59,035		-\$11,194	-23.40%	1,239 vs. 1,254 1.20%
- Predicted w/ actual Fuel Prices	\$58,175		-\$10,334	-21.60%	40.32 vs. 40.32 0.00%

Figure 8: Prediction Analysis of Pacific Fleet DDG-51 Ship Class Fuel Cost for FY 2002

Applying the decomposition method to these results uncovers some of the reasons for the difference between actual and predicted costs. The reason for inaccuracies in fuel (SF) cost estimates is not as straightforward as the distinction between model error and source data error (See Figure 6, which shows how the “predicted from all actual data” number is calculated). Since analyzing SF cost prediction is not our primary focus, we will briefly review the results. Depending on where we use actual data (e.g. in the beginning of the flowchart by using actual OPMONTH to calculate DUW from it the way the model does; vice using actual DUW, as we would if the data were available) we get a different decomposition.

Figure 8 shows the effect of the source data inaccuracy which, at 6.98%, seems reasonable. This is true in the case of burn rates and fuel prices, but less convincing in the number of days underway. Fuel price is the same as predicted, since ships use a pre-determined fixed price throughout the year and burn rates do not change significantly over time. However, ships in this class were deployed less frequently than expected (for approximately 49 months altogether instead of the predicted 60 months), which caused 150 fewer days underway. This fact is realized in the PFAD, resulting in a lower over-estimated value than predicted compared to the actual cost.

On the other hand, the effect of the model's method shows a significant difference (\$-7.0M, which equals a relative difference of -14.6%). One reason could be the way the model calculates burn rate for the repair days underway. It takes the simple average of non-deployed burn rates (underway and not underway), which results in this case a 271 barrels/day consumption, contrary to the real burn rate of 411 barrels per day⁵.

SU	value	Full effect	Part effect	Weight					
Actual	\$12,553		\$941	7.50%	13.16%				
Predicted	\$11,612		-\$361	-2.87%					
Predicted from All Actual Data	\$11,251		\$1,302	10.37%					
- Predicted w/ actual price growth	\$11,664		\$889	7.08%		Predicted	vs.	Actual	
- Predicted w/ actual OPMONTH	\$11,200		\$1,353	10.77%		132.60%	vs.	133.20%	
						180.70	vs.	174.30	
								difference%	
								0.45%	
								-3.67%	
SR									
SR	value	Full effect	Part effect	Weight					
Actual	\$23,849		-\$3,561	-14.93%	25.00%				
Predicted	\$27,410		\$1,088	4.56%					
Predicted from All Actual Data	\$28,498		-\$4,649	-19.49%					
Predicted w/ actual price growth	\$27,870		-\$4,021	-16.86%		Predicted	vs.	Actual	
- Predicted w/ actual ship year	\$26,972		-\$3,123	-13.09%		98.40%	vs.	99.99%	
- Predicted w/ actual incr. cost	\$28,483		-\$4,634	-19.43%		16.25	vs.	16.00	
						-1,073	vs.	0	
								#DIV/0!	
								-1.56%	
SO									
SO	value	Full effect	Part effect	Weight					
Actual	\$11,147		-\$4,784	-42.92%	11.69%				
Predicted	\$15,931		-\$271	-2.43%					
Predicted from All Actual Data	\$15,660		-\$4,513	-40.48%					
- Predicted w/ actual price growth	16,324		-\$5,177	-46.44%		Predicted	vs.	Actual	
- Predicted w/ actual ship year	15,692		-\$4,545	-40.78%		98.70%	vs.	101.20%	
- Predicted w/ actual incr. cost	15,511		-\$4,364	-39.15%		16.25	vs.	16.00	
						419	vs.	0	
								#DIV/0!	
								-1.56%	
								2.47%	

Figure 9: Prediction Analysis of Pacific Fleet DDG-51 Ship Class SU, SR and SO Costs for 2002

⁵ Though this difference is significant the repair days underway weight within the SF calculation is small.

In each of the remaining three cases (SU, SR, SO) we can draw similar conclusions. Though the proportion of inaccuracy fluctuates (7.5%, 14.9% and 42.9% see Figure 9), all show the original prediction problems stem mainly from the model's calculation method (effects respectively: 10.4%, 19.5% and 40.5%). Even if the planner had known what was going to happen in the coming year (in terms of the cost drivers and adjustments ship years, operation months price growths, and price growths and incremental costs respectively) using the current model's method, he would have arrived at almost the same result. However, in an individual case it can come from natural variation of costs over time; using across-the-board examples we can determine whether it is a general tendency or not.

For the selected ship classes and for each of the years from 1997 through 2002 we ran comparisons measuring the second component effect (model's inaccuracy). The detailed results are in Appendix B, but percentage errors and the calculated measures from are summarized in the tables below.

Year / CL	DDG-51CL	CG-47CL	DD-963CL	FFG-7CL	LHA-1CL
1997	-9.39%	-6.49%	-4.34%	-8.87%	18.24%
1998	-12.91%	-0.73%	6.75%	-5.98%	11.30%
1999	1.64%	-2.37%	-3.29%	-0.31%	13.93%
2000	15.36%	22.97%	29.19%	19.41%	16.71%
2001	-5.43%	-4.84%	0.06%	-2.54%	21.00%
2002	-15.57%	-12.35%	-17.20%	-14.55%	-3.51%

Mean = 1.53%

StDev = 12.82%

t-value = 0.65

p-value = 0.5187

MAPE = 10.24%

w/o 2000 = 8.14%

Table 5: Prediction Appraisal of Selected Ship Classes' Total Costs

Table 5 shows the overall results obtained by analyzing the selected ship classes' total costs (excluding CT and NSI). The calculated p-value (0.5187) implies strong evidence for not rejecting the null hypothesis, which theoretically means insufficient evi-

dence against H_0 , but practically, it yields a good overall result that implies a good model on the total cost level. However we should highlight the deficiencies of this analysis. By using simple averages we do not take into consideration the different ship classes.

On the other hand, both the MAPE and the adjusted MAPE (by excluding year 2000 data, as discussed in Chapter III, because its fuel cost figures are obviously outliers, for which we could not find convincing explanation) show a fairly good picture. It says, across our sample, the total cost was predicted with an average error of 8-10% underestimation of cost figures. As mentioned before, there is no objective method to evaluate this number. So it is just our perception that determines this as fairly good.

As we will see, the hypothesis test determines whether or not the model makes mistakes systematically or randomly. On the other hand, MAPE gives details about its ex-post precision, regardless of the possible fact that the model was inaccurate more frequently in one direction than the other.

Using the same methodology, we can assess the precision of prediction separately for each cost group. We begin with the fuel cost, see Table 6.

Year / CL	DDG-51CL	CG-47CL	DD-963CL	FFG-7CL	LHA-1CL
1997	3.24%	-7.21%	-3.84%	-34.35%	11.64%
1998	0.94%	5.17%	-0.98%	-30.03%	25.12%
1999	-7.43%	-10.19%	-4.29%	-1.36%	17.40%
2000	54.10%	51.04%	41.89%	51.72%	36.12%
2001	-11.39%	-7.56%	-9.72%	-19.31%	41.49%
2002	-14.62%	-16.82%	-11.86%	-26.00%	15.69%

Mean = 4.62%

StDev = 24.91%

MAPE = 19.08%

w/o 2000

= 13.51%

t-value = 1.02

p-value = 0.3180

Table 6: Prediction Analysis of Selected Ship Classes' Fuel Cost

The p-value (0.32) gives quite strong evidence against systemic errors, however the MAPE even without year 2000 data shows only a fair result. Especially in certain ship classes (e.g. FFG-7 or LHA-1) this inaccuracy is significant and presents systematic patterns (continuous over and underestimation respectively). However, we should note again, in the case of SF, the predicted value from all actual data heavily depends on where you put actual data into the model. Since this cost group has the most obvious connection to OPTEMPO (e.g. days underway) actual data yield the above results.

Year / CL	DDG-51CL	CG-47CL	DD-963CL	FFG-7CL	LHA-1CL
1997	16.69%	10.08%	8.99%	11.15%	34.77%
1998	25.30%	12.13%	13.24%	7.84%	-44.10%
1999	7.11%	-9.38%	2.39%	14.95%	12.67%
2000	2.70%	3.39%	2.61%	3.83%	-4.03%
2001	9.36%	-1.86%	2.54%	-5.89%	7.54%
2002	10.37%	14.81%	-11.37%	-0.79%	4.52%

Mean = 5.39%

StDev = 13.32%

MAPE = 10.55%

t-value = 2.21

p-value = 0.0348

Table 7: Prediction Appraisal of Selected Ship Classes' Utility Cost

Results from the analysis of utility cost are somewhat surprising (see the summary in Table 7). Although the MAPE shows the best results among all cost elements, the p-value indicates systematic problems with the model at 96.5% certainty level. This indicates a statistically significant one-direction deviation from the actual data, which is easily observable examining the graph like the one in Figure 10.

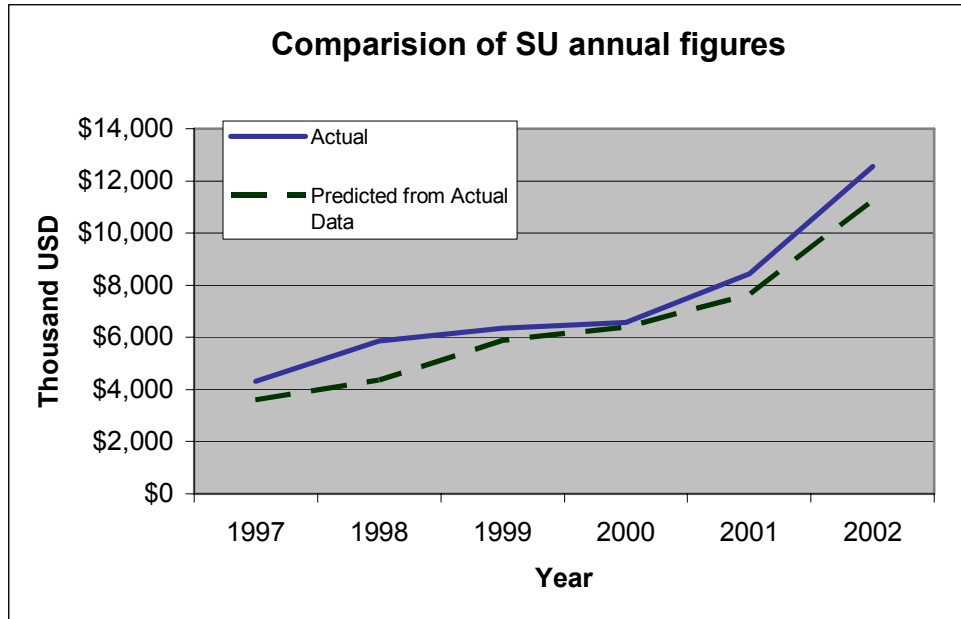

Figure 10: Actual Versus PFAD for Pacific Fleet DDG-51 Ships

As the example above also shows, SU cost is mostly underestimated if we use actual execution data as inputs to the model. This seems to be permanent, as the p-value confirmed, but whether it is intended or not we don't know. An intended flaw might be explained by the commonly used under-financing technique (i.e. 90%) in the beginning of the year (when the model is mainly used), in order not to exceed 100% of the obligations by the end of the year, so as to avoid overspending. If it is not intended, it would be worth analyzing more closely. In our view, we think we are observing one of the disadvantages of moving average, which happens if there is a continuous upward or downward trend in the data, where moving average under and overestimates respectively. Correcting this would probably not require big changes in the model (just adding the average difference to the prediction in the case of underestimation), but it will work properly while the (upward) trend continues, otherwise it would have the opposite effect by causing further inaccuracies. The planners probably have more information about future trends based on which they can decide whether or not they are better off with the correction.

Year / CL	DDG-51CL	CG-47CL	DD-963CL	FFG-7CL	LHA-1CL
1997	-24.42%	1.59%	1.87%	9.55%	36.91%
1998	-55.64%	-19.26%	4.87%	8.15%	-15.24%
1999	-2.52%	-4.39%	2.82%	7.80%	-10.94%
2000	1.59%	18.78%	25.65%	3.45%	20.70%
2001	0.60%	-0.17%	-1.12%	-5.79%	6.82%
2002	-19.49%	-13.95%	-30.57%	-17.89%	-51.00%

Mean = -4.04%

StDev = 19.94%

t-value = 1.11

p-value = 0.2763

SR

MAPE = 14.12%

Year / CL	DDG-51CL	CG-47CL	DD-963CL	FFG-7CL	LHA-1CL
1997	-44.46%	-41.52%	-35.06%	-10.34%	-18.13%
1998	-11.16%	6.50%	28.34%	6.07%	26.85%
1999	23.85%	24.20%	-17.26%	-25.70%	23.09%
2000	-57.40%	-21.66%	22.98%	6.54%	5.64%
2001	-6.17%	-9.47%	25.24%	29.83%	8.95%
2002	-40.48%	-17.52%	-16.03%	6.82%	-22.95%

Mean = -5.01%

StDev = 24.82%

t-value = 1.11

p-value = 0.2775

SO

MAPE = 21.34%

Table 8: Prediction Analysis of Selected Ship Classes' SR and SO Cost

We will discuss the last two cost elements together, because they are calculated using the same method, namely based on ship years (number of ships in commissioned status in a given year). As shown in Table 8 their p-values are very similar, at a minimum showing a lack of sufficient evidence against systematic errors. Despite the fact that this statistical test shows the errors are evenly distributed, there are significant inaccura-

cies, especially in the prediction of SO. These fairly high (in our judgment) MAPE results underpin the need for some improvement in these cases.

Comparison of results across cost elements is debatable due to the different characteristics of spending. But, comparing MAPE results indicates the possibility of improving cost estimation in the last two cases by incorporating some kind of operational data into the model.

Before we begin the discussion of our attempts to improve the model, let us quickly look through the results for full comparisons of year 2002. Since it represents just one year we can draw very limited conclusions about the model's total accuracy.

As can be seen in the "Analysis of Prediction for FY 2002" pages of Appendix B, the model's total inaccuracy ranges from a very good result of -0.67% (FFG-7) to a fairly imprecise outcome of 18.6% (DDG-51). Nevertheless, the model's inaccuracy component effect shows mostly a low two-digit difference (fair result). This is sometimes balanced by an opposite deviation caused by imprecise input (especially in case of FFG-7, where all together it results in a very good total effect; however both partial effects show fair outcomes). Greater total inaccuracies occur when both the model's component effect and the input component effect cause errors in the same direction, such as the DDG-51 and LHA-1 ship classes.

However, further analysis can be conducted in the same way it was described in this section, we would like to draw the reader's attention to one more outstanding trend in the 2002 full analysis results. Almost unanimously, the quite considerable total differences at SR and SO (with a highest of -42.9% for DDG-51) come primarily from the component effect of the model's inaccuracy. However, the decomposition method at this level shows no significant problem with the source data (the maximum effect was 8.9% for DD-963).

After analyzing the current techniques to determine predicted costs at the special interest item and ship class level, the next chapter is our attempt to improve upon the current methods of prediction.

V. MODIFIED MODEL PROPOSAL

A. INTRODUCTION

In Chapter V we will discuss our findings for developing a new Ship Ops model. As previously stated our research focuses on improving the predictive capability of the current model in the Special Interest Items of SR (Repair Parts) and SO (OPTAR, Other). We will use as a benchmark for comparison the Mean Absolute Percentage Error (MAPE) analysis completed in Chapter IV. Our modified model will be compared against the current model to determine whether we have succeeded in improving the model's predictive capability.

In order to build a modified model, we took several approaches. First, we collected data from the Type Commanders (TYCOMs) on individual ships. For example, the following is a sample of the data SURFPAC provided for the USS BRIDGE.

AOE			1999	2000	2001	2002
	BRIDGE	CT				\$99,600
		SO	\$904,900	\$1,355,900	\$1,083,300	\$1,495,200
		SR	\$1,115,400	\$1,395,100	\$948,900	\$1,449,300
		SU	\$9,800	\$113,600	\$105,700	\$192,100
			\$2,030,100	\$2,864,600	\$2,137,900	\$3,236,200

Table 9: Example of TYCOM Cost Data

Other TYCOMs provided similar data. We were able to assign costs based on hull number as opposed to aggregating the data into ship classes, as is the process in the current model. This increased the number of data points and offered a different perspective from the current methodology. We also performed regression analysis on the aggregated data in the current model. We looked to find relationships in that data which were more significant than Ship Years.

The primary flaw with the current model is that there are no cost drivers other than Ship Years. In essence the model treats all costs as fixed, based on a ship being in

commission during a given year. Our modified model seeks to identify the fixed cost (a constant in the cost equation) and cost drivers related to operations that could reveal the underlying variable cost of operating ships. In order to do this we have collected operational information from the NEURS database which identifies a ship's days underway. Further segregation of the data is possible when one considers the OPCON information found in the NEURS database. From the OPCON, we are able to group a ship's days underway into multiple categories. For example, LANTFLT ships reporting OPCON 08 are underway while not deployed.

In the event we could not determine a relationship between costs and operational variables, we looked to improve on the current model's MAPE by finding relationships between cost data and fiscal year (FY). In most ship classes, we determined a statistically significant relationship exists between costs and the FY. This is especially relevant given the uncertainty surrounding the current inflation factors (discussed in Chapter III). By using FY as an independent variable, we are able to incorporate the historically realized rate of inflation without inputting an arbitrary inflation factor.

In selecting which regressions to use in our modified model, we chose the equation that resulted in the lowest MAPE. In some cases, we were unable to find a relationship between costs and operational data. In other cases, we found marked improvement by including operational data as drivers for forecasting costs. Our modified model incorporates these improvements, where available, with the current method of using three-year averages. We have determined that for SR, our modified model demonstrates its improvement over the current model through its lower overall MAPE (13.39% for the modified model vs. 20.27% for the current model) as well as a MAPE for each ship class that is lower or equal to the current model. For SO, we were able to produce only fractional improvement in MAPE when compared with the original model.

B. DEVELOPING THE MODIFIED MODEL

This section (Tables 11 and 12) presents the regressions that were found to have the lowest MAPE for each of the ship classes analyzed, MAPEs for each model compared can be found in Appendix H. Regressions were run to find relationships between

repair parts (SR) cost, consumable (SO) costs and operating data. An independent variable for the year was considered. Referred to as “FY”, this variable aimed to include trends from year to year, to include inflation. An indicator variable was included to differentiate between Pacific and Atlantic Fleet ships when regressions were run on all the ships of a class. This variable was referred to as “Pac Flt.” This variable has a value of either “1” for a Pacific Fleet ship or “0” for an Atlantic Fleet ship. This variable was not included when the regressions were done for the individual fleets since it was not required.

Based on the information in the NUERS database, five possible independent variables could be considered. The first was days underway while not deployed and was identified as “UW not dep.” There were three variables to consider for days underway while deployed. Days underway deployed to the Fifth Fleet Area of Responsibility (AOR) are identified separately in the NUERS database by OPCON code 17. The variable representing this is “code 17” in the following regressions. When ships were deployed but not to the Fifth Fleet AOR, these days were represented by the variable “UW dep not 17”. Finally, the variable “Total UW deployed” is the summation of the previous two variables. The last variable “Total UW” considers the total number of days underway deployed and not deployed.

Some exceptions apply. Due to the lack of data points, regressions by class do not consider whether a ship is deployed to the Fifth Fleet or not, only that it is underway deployed. Further, in order to keep with the model’s current convention of computing unit cost for SR and SO and then multiplying by the number of Ship Years, we have decided to use the dependant variable SR per ship (or SO per ship) when determining the equation to predict costs by class.

To summarize, the variables used in the following regressions and their meanings are as follows:

Dependent Variables	
SR	A dependent variable to estimate repair parts costs for a ship in the class when using “by hull” data.
SO	A dependent variable to estimate SO for a ship in the class consumable costs for a ship in the class when using “by hull” data.
SR per ship	A dependent variable to estimate SR costs when using class data.
SO per ship	A dependent variable to estimate SO costs when using class data.
Independent Variables	
FY	An independent variable representing the current fiscal year. Fiscal Year 2000 was used as the base (00). Therefore fiscal year 1999 is represented by a negative one (-1) and fiscal year 2001 by a positive one (1).
Pac Flt	A binary (one or zero) indicator variable to represent the fleet in which a ship is home ported. A ship assigned to the Atlantic Fleet would have a value of zero and one assigned to the Pacific Fleet would have a value of one.
UW not dep	Represents the days spent underway and while not in a deployed status. In the NUERS database this is represented by the time spent in code eight.
Code 17	Represents the days underway on deployment while in the 5 th Fleet AOR. This time is represented by code 17 in the NUERS database.
UW dep not 17	Represents the days spent underway and on deployment when operating in areas SO than the 5 th fleet AOR. This is represented by the code nine in the NUERS database.
Total UW deployed	Is the summation of the days under “Code 17” and “Total UW deployed.” This represents the total number of days underway while in a deployed status.
Total UW	Represents the total number of days a ship was underway in a year. It is the summation of the time spent in codes eight, nine and seventeen in the NUERS database.
Total UW / SY	The total days underway for a class during a year divided by the ship years. This represents the average number of days underway per ship.

Table 10: Variables used in Regressions

Multiple regressions were run in Minitab (a commercial statistical software package) to consider the various combinations of these variables. In order to find any relationships that exist across an entire class, the ships were aggregated by class and fleet. Then the ships were divided into their respective fleets and further regressions were performed to find any relationships that were fleet specific.

There are a few exceptions to this practice. Only ships from the Atlantic Fleet were considered for the CVN-68 class. Data for the Pacific Fleet ships of this class were not available. The MCM class does not have ships assigned to the Pacific Fleet. Ships are home ported in the Atlantic Fleet, Bahrain and Japan. Although assigned to Japan, for budgeting purposes these ships are considered part of the Atlantic Fleet. Regressions performed on this class of ship were separated by homeport, Atlantic, Bahrain and Japan. The MHC class had a similar issue since these ships are only home ported in Bahrain.

A summary of the regressions, subdivided by Other Consumables (SO) and Repair Parts (SR), can be found in Appendix C. The corresponding MAPE for each regression equation is included. The MAPE was obtained by comparing the error produced by the predictive regression and the actual costs, as discussed in Chapter 4. The complete statistical evaluation of the regressions including an analysis of variance (ANOVA) can be found in Appendices D and E. Only regressions that were significant to the 90% level for the regression, as well as all independent variables, were included in these appendices.

Appendix F includes only the equations from Appendices D and E that consider at least one or more operationally based variables (e.g.: days underway). Appendix F is intended to aid in calculating supplemental costs.

C. EVALUATING OUR MODEL

We established which classes of ships have demonstrated a significant relationship to either an operational variable (days underway) or a sequential variable (FY). We constructed our modified model based on the premise that if we lower the MAPE for any portion of the model we improve the predictive capability of the model. With that in

mind, Tables 11 and 12 demonstrate which classes (in which fleets) have a statistically significant relationship with a variable, not included in the current model that could improve the predictive capability over the current model.

SO	Best Value	Best Method	Best Method Equation
Atlantic Fleet			
AOE-1CL	10.10%	Original Model	3-year average
AOE-6CL	15.10%	Regression by HULL	SO = 389230 - 95086 FY + 2493 Total UW
MHC-51CL	30.80%	Regression by HULL Combined	SO = 191950 + 46602 FY
LHA-1CL	7.10%	Regression by Class	SO per ship = 2457.304 + 118.0714 FY
LHD-1CL	9.40%	Regression by Class	SO per ship = 2281.057 + 125.4181 FY
LPD-4CL	10.30%	Regression by HULL	SO = 753710 + 49124 FY
LSD-36CL	27.50%	Regression by HULL Combined	SO = 869294 + 226643 FY
LSD-41CL	20.50%	Regression by HULL Combined	SO = 384471 + 46986 FY + 370971 Pac Fit + 1803 Total UW
CG-47CL	6.40%	Regression by Class	SO per ship = 868.7925 + 36.67772 FY
DDG-51CL	6.70%	Regression by Class	SO per ship = 711.387 + 18.74133 FY
DD-963CL	6.00%	Regression by Class	SO per ship = 754.3822 + 18.24094 FY
FFG-7CL	3.70%	Regression by Class	SO per ship = 617.0314 + 24.24533 FY
ARS-50CL	7.00%	Regression by Class	SO per ship = 469.818 + 45.26488 FY
CVN-68CL	9.52%	Original Model	3-year average
Pacific Fleet			
AOE-1CL	16.87%	Original Model	3-year average
AOE-6CL	19.90%	Regression by HULL Combined	SO = 230024 + 585647 Pac Fit + 3912 Total UW
LHA-1CL	10.50%	Regression by Class	SO per ship = 1442.206 + 184.4804 FY + 12.8445 Total UW / SY
LHD-1CL	14.70%	Regression by Class Combined	SO per ship = 2399.275 + 172.722 FY + 447.1553 Pac Fit
LPD-4CL	7.30%	Regression by Class	SO per ship = 1333.153 + 81.15278 FY
LSD-36CL	13.80%	Regression by Class	SO per ship = 1124.714 + 85.91071 FY
LSD-41CL	19.00%	Regression by HULL	SO = 513888 + 3846 Total UW
CG-47CL	14.30%	Regression by HULL Combined	SO = 519990 + 70221 FY + 244877 Pac Fit + 1061 Total UW
DDG-51CL	20.80%	Regression by HULL	SO = 126572 + 40860 FY + 4890 UW N.D. + 5099 UW Depl. Not 17+ 3320 Code 17
DD-963CL	14.40%	Regression by Class Combined	SO per ship = 876.4264 + 42.34407 FY
FFG-7CL	10.60%	Regression by Class Combined	SO per ship = 704.0872 + 36.86082 FY
ARS-50CL	11.80%	Regression by Class Combined	SO per ship = 473.4271 + 46.69583 FY + 231.9125 Pac Fit
CVN-68CL	20.00%	Original Model	3-year average

Table 11: Best MAPE by Type of Regression SO

SR	Best Value	Best Method	Best Method Equation
Atlantic Fleet			
AOE-1CL	9.84%	Original Model	3-year average
AOE-6CL	12.60%	Regression by Class	SR per ship = 1667.023 + 92.30497 FY
MCM-1CL	13.37%	Original Model	3-year average
MHC-51CL	40.00%	Regression by HULL Combined	SR = 492140 + 164273 FY
LHA-1CL	15.20%	Regression by Class Combined	SR per ship = 2148.285 + 91.33448 FY
LHD-1CL	8.63%	Original Model	3-year average
LPD-4CL	10.74%	Original Model	3-year average
LSD-36CL	17.94%	Original Model	3-year average
LSD-41CL	12.84%	Original Model	3-year average
CG-47CL	9.90%	Original Model	3-year average
DDG-51CL	8.90%	Regression by Class	SR per ship = 1328 - 98.0074 FY
DD-963CL	4.40%	Regression by Class	SR per ship = 1958.267 + 65.34286 FY
FFG-7CL	3.00%	Regression by Class	SR per ship = 1450.977 + 43.07232 FY
ARS-50CL	11.90%	Regression by HULL	SR = 414091 + 48712 FY
CVN-68CL	26.90%	Regression by HULL	SR = 3332599 + 731389 FY + 23395 Total UW
Pacific Fleet			
AOE-1CL	19.60%	Regression by HULL Combined	SR = 1582192 + 210046 FY - 446790 Pac Fit
AOE-6CL	14.70%	Regression by HULL Combined	SR = 461317 - 290374 Pac Fit + 10861 UW not dep + 5132 Total UW deployed
LHA-1CL	14.40%	Regression by Class	SR per ship = 2349.507 + 176.3022 FY
LHD-1CL	10.26%	Original Model	3-year average
LPD-4CL	11.65%	Original Model	3-year average
LSD-36CL	2.80%	Regression by HULL	SR = 132195 + 210146 FY + 6100 UW not dep + 3526 Total Dep UW
LSD-41CL	17.00%	Regression by HULL	SR = 881305 - 56488 FY
CG-47CL	9.69%	Original Model	3-year average
DDG-51CL	10.40%	Original Model	3-year average
DD-963CL	9.10%	Regression by Class	SR per ship = 2033.559 + 122.1649 FY
FFG-7CL	4.90%	Regression by Class	SR per ship = 1328.088 + 53.5 FY
ARS-50CL	13.60%	Regression by HULL Combined	SR = 414091 + 57674 FY + 252672 Pac Fit
CVN-68CL	22.23%	Original Model	3-year average

Table 12: Best MAPE by Type of Regression SR

We have demonstrated that in some cases the current model is the most accurate means of predicting costs (Lower MAPE or no significant regressions were found), while in other cases a driver other than ship years is more appropriate. Tables 13 and 14 show the actual cost by class and fleet, the PFAD (the best possible output of the model) and the modified model's predicted cost for 2002, 2001 and 2000.

SR - 2002	Actual Cost	Weighting	PFAD	PFAD Weighted MAPE	Best Method's Prediction	Best Method's Weighted MAPE
Atlantic Fleet						
AOE-1CL	\$3,343	0.99%	\$3,092	0.08%	\$3,092	0.08%
AOE-6CL	\$792	0.23%	\$1,113	0.07%	\$1,111	0.07%
MCM-1CL	\$9,176	2.72%	\$7,223	0.74%	\$7,223	0.74%
MHC-51CL	\$1,316	0.39%	\$2,761	0.20%	\$1,641	0.08%
LHA-1CL	\$6,846	2.03%	\$4,248	1.24%	\$4,662	0.95%
LHD-1CL	\$9,015	2.67%	\$9,327	0.09%	\$9,327	0.09%
LPD-4CL	\$4,351	1.29%	\$4,129	0.07%	\$4,129	0.07%
LSD-36CL	\$876	0.26%	\$790	0.03%	\$790	0.03%
LSD-41CL	\$6,714	1.99%	\$5,032	0.67%	\$5,032	0.67%
CG-47CL	\$40,254	11.94%	\$36,397	1.27%	\$36,397	1.27%
DDG-51CL	\$28,455	8.44%	\$25,821	0.86%	\$21,055	2.97%
DD-963CL	\$21,029	6.24%	\$20,728	0.09%	\$21,934	0.26%
FFG-7CL	\$22,554	6.69%	\$21,235	0.42%	\$23,057	0.15%
ARS-50CL	\$832	0.25%	\$740	0.03%	\$1,023	0.05%
CVN-68CL	\$32,033	9.50%	\$24,269	3.04%	\$26,715	1.89%
Pacific Fleet						
AOE-1CL	\$2,682	0.80%	\$2,107	0.22%	\$3,111	0.11%
AOE-6CL	\$2,414	0.72%	\$2,086	0.11%	\$2,493	0.02%
LHA-1CL	\$5,226	1.55%	\$7,891	0.52%	\$8,106	0.55%
LHD-1CL	\$7,068	2.10%	\$7,499	0.12%	\$7,499	0.12%
LPD-4CL	\$5,178	1.54%	\$5,852	0.18%	\$5,852	0.18%
LSD-36CL	\$1,943	0.58%	\$1,690	0.09%	\$2,488	0.13%
LSD-41CL	\$4,899	1.45%	\$5,749	0.21%	\$3,842	0.40%
CG-47CL	\$32,843	9.74%	\$37,424	1.19%	\$37,424	1.19%
DDG-51CL	\$23,849	7.08%	\$28,498	1.15%	\$28,498	1.15%
DD-963CL	\$17,310	5.14%	\$22,602	1.20%	\$21,412	0.98%
FFG-7CL	\$13,580	4.03%	\$16,010	0.61%	\$15,786	0.56%
ARS-50CL	\$1,191	0.35%	\$1,547	0.08%	\$1,564	0.08%
CVN-68CL	\$31,301	9.29%	\$29,518	0.56%	\$29,518	0.56%
WEIGHTED MAPE				15.14%		15.39%
LANTFLEET SUM	\$187,586		\$166,906		\$167,188	
PACFLEET SUM	\$149,484		\$168,472		\$167,592	
TOTAL SUM	\$337,070		\$335,378		\$334,780	

Table 13: MAPE Comparison for PFAD and the Modified Model SR

2002

SR - 2001	Actual Cost	Weighting	PFAD	PFAD Weighted MAPE	Best Method's Prediction	Best Method's Weighted MAPE
Atlantic Fleet						
AOE-1CL	\$3,029	0.95%	\$3,009	0.01%	\$3,009	0.01%
AOE-6CL	\$3,027	0.95%	\$2,798	0.08%	\$2,991	0.01%
MCM-1CL	\$6,177	1.93%	\$7,724	0.39%	\$7,724	0.39%
MHC-51CL	\$6,001	1.87%	\$449	23.20%	\$1,313	6.70%
LHA-1CL	\$3,863	1.21%	\$4,317	0.13%	\$4,479	0.17%
LHD-1CL	\$7,655	2.39%	\$7,147	0.17%	\$7,147	0.17%
LPD-4CL	\$3,858	1.21%	\$4,191	0.10%	\$4,191	0.10%
LSD-36CL	\$676	0.21%	\$819	0.04%	\$819	0.04%
LSD-41CL	\$3,963	1.24%	\$5,210	0.30%	\$5,210	0.30%
CG-47CL	\$38,524	12.04%	\$33,635	1.75%	\$33,635	1.75%
DDG-51CL	\$23,959	7.49%	\$25,786	0.53%	\$21,648	0.80%
DD-963CL	\$25,002	7.81%	\$21,155	1.42%	\$23,069	0.65%
FFG-7CL	\$25,607	8.00%	\$22,486	1.11%	\$23,905	0.57%
ARS-50CL	\$395	0.12%	\$739	0.06%	\$926	0.07%
CVN-68CL	\$7,251	2.27%	\$33,458	1.77%	\$26,830	1.65%
Pacific Fleet						
AOE-1CL	\$2,859	0.89%	\$1,655	0.65%	\$2,691	0.06%
AOE-6CL	\$2,317	0.72%	\$1,839	0.19%	\$2,872	0.14%
LHA-1CL	\$7,650	2.39%	\$7,129	0.17%	\$7,577	0.02%
LHD-1CL	\$6,279	1.96%	\$7,122	0.23%	\$7,122	0.23%
LPD-4CL	\$6,006	1.88%	\$5,653	0.12%	\$5,653	0.12%
LSD-36CL	\$1,656	0.52%	\$1,659	0.00%	\$1,665	0.00%
LSD-41CL	\$5,269	1.65%	\$5,165	0.03%	\$3,299	0.98%
CG-47CL	\$35,017	10.94%	\$35,075	0.02%	\$35,075	0.02%
DDG-51CL	\$23,462	7.33%	\$23,320	0.04%	\$23,320	0.04%
DD-963CL	\$22,984	7.18%	\$23,241	0.08%	\$22,635	0.11%
FFG-7CL	\$15,295	4.78%	\$16,181	0.26%	\$15,197	0.03%
ARS-50CL	\$1,520	0.47%	\$1,598	0.02%	\$1,449	0.02%
CVN-68CL	\$30,787	9.62%	\$31,250	0.14%	\$31,250	0.14%
WEIGHTED MAPE				33.01%		15.28%
LANTFLEET SUM	\$158,987		\$172,925		\$166,897	
PACFLEET SUM	\$161,101		\$160,886		\$159,805	
TOTAL SUM	\$320,088		\$333,811		\$326,702	

Table 14: MAPE Comparison for PFAD and the Modified Model SR

2001

SR - 2000	Actual Cost	Weighting	PFAD	PFAD Weighted MAPE	Best Method's Prediction	Best Method's Weighted MAPE
Atlantic Fleet						
AOE-1CL	\$2,665	0.83%	\$2,340	0.12%	\$2,340	0.12%
AOE-6CL	\$3,067	0.96%	\$2,447	0.24%	\$3,334	0.08%
MCM-1CL	\$7,509	2.35%	\$7,570	0.02%	\$7,570	0.02%
MHC-51CL	\$873	0.27%	\$480	0.22%	\$984	0.03%
LHA-1CL	\$4,208	1.32%	\$3,182	0.42%	\$4,297	0.03%
LHD-1CL	\$5,449	1.70%	\$6,125	0.19%	\$6,125	0.19%
LPD-4CL	\$4,125	1.29%	\$3,378	0.29%	\$3,378	0.29%
LSD-36CL	\$793	0.25%	\$743	0.02%	\$743	0.02%
LSD-41CL	\$4,924	1.54%	\$4,800	0.04%	\$4,800	0.04%
CG-47CL	\$32,430	10.14%	\$32,459	0.01%	\$32,459	0.01%
DDG-51CL	\$21,917	6.85%	\$20,220	0.58%	\$20,318	0.54%
DD-963CL	\$24,236	7.58%	\$22,508	0.58%	\$25,457	0.36%
FFG-7CL	\$22,179	6.94%	\$20,814	0.45%	\$23,216	0.31%
ARS-50CL	\$889	0.28%	\$562	0.16%	\$828	0.02%
CVN-68CL	\$30,087	9.41%	\$30,070	0.01%	\$27,812	0.77%
Pacific Fleet						
AOE-1CL	\$1,909	0.60%	\$1,446	0.19%	\$2,271	0.10%
AOE-6CL	\$2,685	0.84%	\$1,599	0.57%	\$2,424	0.09%
LHA-1CL	\$8,035	2.51%	\$6,372	0.66%	\$7,049	0.35%
LHD-1CL	\$6,543	2.05%	\$7,725	0.31%	\$7,725	0.31%
LPD-4CL	\$5,490	1.72%	\$5,417	0.02%	\$5,417	0.02%
LSD-36CL	\$1,704	0.53%	\$1,446	0.10%	\$1,534	0.06%
LSD-41CL	\$5,437	1.70%	\$4,448	0.38%	\$4,407	0.40%
CG-47CL	\$35,726	11.17%	\$29,016	2.58%	\$29,016	2.58%
DDG-51CL	\$19,562	6.12%	\$19,250	0.10%	\$19,250	0.10%
DD-963CL	\$25,828	8.08%	\$19,202	2.79%	\$22,369	1.25%
FFG-7CL	\$14,512	4.54%	\$14,011	0.16%	\$14,609	0.03%
ARS-50CL	\$1,744	0.55%	\$1,311	0.18%	\$1,449	0.11%
CVN-68CL	\$25,273	7.90%	\$21,732	1.29%	\$21,732	1.29%
WEIGHTED MAPE				12.67%		9.50%
LANTFLEET SUM	\$165,351		\$157,697		\$163,663	
PACFLEET SUM	\$154,447		\$132,975		\$139,250	
TOTAL SUM	\$319,798		\$290,672		\$302,913	

Table 15: MAPE Comparison for PFAD and the Modified Model SR

2000

SO - 2002	Actual Cost	Weighting	PFAD	PFAD Weighted MAPE	Best Method's Prediction	Best Method's Weighted MAPE
Atlantic Fleet						
AOE-1CL	\$2,835	1.22%	\$3,043	0.08%	\$3,043	0.08%
AOE-6CL	\$466	0.20%	\$767	0.08%	\$304	0.11%
MHC-51CL	\$848	0.37%	\$1,153	0.10%	\$570	0.18%
LHA-1CL	\$7,378	3.18%	\$4,614	1.91%	\$5,387	1.18%
LHD-1CL	\$11,288	4.87%	\$9,699	0.80%	\$7,596	2.37%
LPD-4CL	\$6,339	2.74%	\$5,123	0.65%	\$4,260	1.34%
LSD-36CL	\$1,525	0.66%	\$705	0.77%	\$1,323	0.10%
LSD-41CL	\$6,855	2.96%	\$4,214	1.85%	\$4,073	2.02%
CG-47CL	\$16,497	7.12%	\$12,418	2.34%	\$13,202	1.78%
DDG-51CL	\$17,606	7.60%	\$13,319	2.45%	\$11,458	4.08%
DD-963CL	\$9,412	4.06%	\$8,114	0.65%	\$10,281	0.34%
FFG-7CL	\$12,952	5.59%	\$9,292	2.20%	\$10,648	1.21%
ARS-50CL	\$1,220	0.53%	\$943	0.15%	\$1,121	0.05%
CVN-68CL	\$40,720	17.57%	\$41,281	0.24%	\$41,281	0.24%
Pacific Fleet						
AOE-1CL	\$2,601	1.12%	\$2,918	0.12%	\$2,918	0.12%
AOE-6CL	\$2,449	1.06%	\$2,697	0.10%	\$2,742	0.11%
LHA-1CL	\$7,563	3.26%	\$9,299	0.61%	\$10,636	0.94%
LHD-1CL	\$7,112	3.07%	\$8,500	0.50%	\$9,576	0.79%
LPD-4CL	\$6,667	2.88%	\$8,319	0.57%	\$8,973	0.74%
LSD-36CL	\$2,714	1.17%	\$2,351	0.18%	\$2,593	0.05%
LSD-41CL	\$4,794	2.07%	\$6,907	0.63%	\$4,904	0.05%
CG-47CL	\$12,106	5.22%	\$14,227	0.78%	\$11,426	0.31%
DDG-51CL	\$11,147	4.81%	\$15,660	1.39%	\$13,644	0.88%
DD-963CL	\$8,350	3.60%	\$9,688	0.50%	\$10,092	0.62%
FFG-7CL	\$8,465	3.65%	\$7,888	0.27%	\$9,166	0.28%
ARS-50CL	\$1,231	0.53%	\$1,370	0.05%	\$1,597	0.12%
CVN-68CL	\$20,610	8.89%	\$22,157	0.62%	\$22,157	0.62%
				20.58%		20.70%
LANTFLEET SUM	\$135,941		\$114,683		\$114,546	
PACFLEET SUM	\$95,809		\$111,981		\$110,424	
TOTAL SUM	\$231,750		\$226,664		\$224,970	

Table 16: MAPE Comparison for PFAD and the Modified Model SO

2002

SO - 2001	Actual Cost	Weighting	PFAD	PFAD Weighted MAPE	Best Method's Prediction	Best Method's Weighted MAPE
Atlantic Fleet						
AOE-1CL	\$2,810	1.14%	\$2,814	0.00%	\$2,814	0.00%
AOE-6CL	\$1,673	0.68%	\$1,811	0.05%	\$1,306	0.19%
MHC-51CL	\$2,382	0.96%	\$1,271	0.84%	\$477	3.85%
LHA-1CL	\$4,806	1.94%	\$5,023	0.08%	\$5,151	0.13%
LHD-1CL	\$8,654	3.50%	\$6,621	1.07%	\$7,941	0.31%
LPD-4CL	\$5,469	2.21%	\$3,664	1.09%	\$4,014	0.80%
LSD-36CL	\$699	0.28%	\$1,131	0.11%	\$1,096	0.10%
LSD-41CL	\$3,299	1.33%	\$4,015	0.24%	\$4,769	0.41%
CG-47CL	\$13,361	5.40%	\$11,258	1.01%	\$12,684	0.29%
DDG-51CL	\$13,285	5.37%	\$12,159	0.50%	\$12,850	0.18%
DD-963CL	\$9,044	3.66%	\$8,248	0.35%	\$8,808	0.10%
FFG-7CL	\$10,853	4.39%	\$9,200	0.79%	\$10,260	0.25%
ARS-50CL	\$1,063	0.43%	\$835	0.12%	\$1,030	0.01%
CVN-68CL	\$49,336	19.95%	\$39,609	4.90%	\$39,609	4.90%
Pacific Fleet						
AOE-1CL	\$4,431	1.79%	\$2,121	1.95%	\$2,121	1.95%
AOE-6CL	\$3,708	1.50%	\$2,613	0.63%	\$2,629	0.62%
LHA-1CL	\$9,678	3.91%	\$8,812	0.38%	\$9,234	0.19%
LHD-1CL	\$8,688	3.51%	\$9,133	0.17%	\$9,057	0.14%
LPD-4CL	\$9,193	3.72%	\$7,723	0.71%	\$8,486	0.31%
LSD-36CL	\$2,155	0.87%	\$2,404	0.09%	\$2,421	0.10%
LSD-41CL	\$7,501	3.03%	\$6,437	0.50%	\$4,044	2.59%
CG-47CL	\$13,333	5.39%	\$14,596	0.47%	\$10,361	1.55%
DDG-51CL	\$12,763	5.16%	\$13,551	0.30%	\$10,951	0.85%
DD-963CL	\$13,239	5.35%	\$9,898	1.81%	\$10,106	1.66%
FFG-7CL	\$11,005	4.45%	\$7,723	1.89%	\$8,761	1.14%
ARS-50CL	\$1,542	0.62%	\$1,347	0.09%	\$1,504	0.02%
CVN-68CL	\$23,319	9.43%	\$21,565	0.77%	\$21,565	0.77%
				20.91%		23.41%
LANTFLEET SUM	\$126,734		\$107,658		\$112,811	
PACFLEET SUM	\$120,555		\$107,923		\$101,241	
TOTAL SUM	\$247,289		\$215,582		\$214,053	

Table 17: MAPE Comparison for PFAD and the Modified Model SO

2001

SO - 2000	Actual Cost	Weighting	PFAD	PFAD Weighted MAPE	Best Method's Prediction	Best Method's Weighted MAPE
Atlantic Fleet						
AOE-1CL	\$3,033	1.51%	\$2,489	0.33%	\$2,489	0.33%
AOE-6CL	\$2,267	1.13%	\$2,146	0.06%	\$1,417	0.68%
MHC-51CL	\$497	0.25%	\$972	0.12%	\$384	0.07%
LHA-1CL	\$4,504	2.24%	\$4,827	0.15%	\$4,915	0.19%
LHD-1CL	\$6,971	3.47%	\$5,451	0.97%	\$6,843	0.06%
LPD-4CL	\$4,929	2.45%	\$3,365	1.14%	\$3,769	0.76%
LSD-36CL	\$745	0.37%	\$1,073	0.11%	\$869	0.05%
LSD-41CL	\$4,803	2.39%	\$3,647	0.76%	\$3,555	0.84%
CG-47CL	\$11,650	5.80%	\$10,681	0.53%	\$12,166	0.25%
DDG-51CL	\$11,547	5.75%	\$9,325	1.37%	\$10,884	0.35%
DD-963CL	\$9,534	4.75%	\$8,968	0.30%	\$9,807	0.13%
FFG-7CL	\$9,545	4.75%	\$8,734	0.44%	\$9,873	0.16%
ARS-50CL	\$944	0.47%	\$697	0.17%	\$940	0.00%
CVN-68CL	\$35,353	17.60%	\$40,652	2.29%	\$40,652	2.29%
Pacific Fleet						
AOE-1CL	\$2,203	1.10%	\$2,041	0.09%	\$2,041	0.09%
AOE-6CL	\$2,270	1.13%	\$2,201	0.04%	\$2,629	0.15%
LHA-1CL	\$8,077	4.02%	\$7,622	0.24%	\$8,398	0.15%
LHD-1CL	\$7,317	3.64%	\$9,419	0.81%	\$8,539	0.52%
LPD-4CL	\$6,989	3.48%	\$7,177	0.09%	\$7,999	0.44%
LSD-36CL	\$2,526	1.26%	\$1,933	0.39%	\$2,249	0.15%
LSD-41CL	\$5,417	2.70%	\$5,737	0.15%	\$5,442	0.01%
CG-47CL	\$11,307	5.63%	\$13,756	1.00%	\$9,417	1.13%
DDG-51CL	\$8,180	4.07%	\$12,875	1.49%	\$8,856	0.31%
DD-963CL	\$11,072	5.51%	\$8,527	1.65%	\$9,202	1.12%
FFG-7CL	\$7,645	3.81%	\$7,145	0.27%	\$8,355	0.32%
ARS-50CL	\$1,184	0.59%	\$1,381	0.08%	\$1,411	0.09%
CVN-68CL	\$20,345	10.13%	\$14,274	4.31%	\$14,274	4.31%
				19.34%		14.97%
LANTFLEET SUM	\$106,322		\$103,028		\$108,560	
PACFLEET SUM	\$94,532		\$94,088		\$88,814	
TOTAL SUM	\$200,854		\$197,116		\$197,375	

Table 18: MAPE Comparison for PFAD and the Modified Model SO

2000

D. RESULTS

From the above data, Table 19 below summarizes the Weighted MAPE for each year.

SR	PFAD	Modified Model
2002	15.14%	15.39%
2001	33.01%	15.28%
2000	12.67%	9.50%
Mean	20.27%	13.39%

SO	PFAD	Modified Model
2002	20.58%	20.70%
2001	20.91%	23.41%
2000	19.34%	14.97%
Mean	20.27%	19.69%

Table 19: Weighted MAPE Summary

The above results demonstrate that the modified model is able to lower the overall MAPE versus the PFAD MAPE for SR. For SO, the modified model has a slightly lower MAPE and indicates that the current model predicts SO costs just as well as the model we developed. We feel that these results are appropriate given the focus of our study. Though we were able to establish relationships between SR cost and operational data for several ship classes, the optimal MAPE was generally the result of regressions with FY as an independent variable. This relationship replaces the current methodology of three-year average with a regression equation. Though we did not observe the improvement we had hoped in the SO model, we feel this is caused partially by the nature of spending in this Special Interest Item. SR cost is driven by specific material or inventory deficiency, SO on the other hand has a tendency to be more discretionary. Given the above results, we recommend using a regression-based model to predict cost for SR and SO.

VI. CONCLUSIONS AND RECOMENDATIONS

A. CONCLUSIONS

By incorporating regression-based predictions for SR we were able to improve the forecasting accuracy, over the last three years, by 6%. However, the improvement was negligible for SO. Regression based predictions improve the predictive capability of the current Ship Ops Model for SR but not for SO. One advantage of the proposed regression based model that should be pointed out is that it provides more flexibility in incorporation of operational data and allow for analysis at the individual ship level.

B. RECOMMENDATIONS

For the ship classes that we were able to determine a significant relationship in predicting costs, we recommend implementing a regression-based model to predict SR and SO. Though the improvement in SO was negligible, the modified model gives the user increased flexibility in predicting costs. We have provided a spreadsheet to FMB that includes our modifications to the current model.

C. AREAS FOR FUTURE RESEARCH

We feel the following represent areas of research that offer the greatest potential for improving cost predictions of O&M,N funds.

1. Alternative Models

By manipulating the drivers used to compute overall cost for Special Interest Items, one could potentially improve the current model without overhauling the current methodology. We performed cursory analysis of the current model by replacing ship years as the driver with OPMONTH and total days underway. We also experimented with extending the period used to obtain the moving average from three years to five. Although detailed analysis of this type of modification is beyond the scope of this project, our initial investigation is included in Appendix G. Our preliminary trials resulted in better MAPEs if we excluded incremental costs and price growths in determining unit costs and future requirements. Further research may be warranted.

2. Submarines

Because submarine data were not available for our study, future research should look to examine relationships between operational variables and submarine SR and SO costs. Additionally, research should be conducted to determine whether SR and SO predictions could be improved through the use of regression equations as opposed to the current three-year average.

3. SF & SU

While the primary focus of our study was SR and SO, we initially (Ch 4) conducted an analysis of the overall model. Though FMB is satisfied with the current model for SF and SU, our preliminary analysis indicates there is potential for improvement in these Special Interest Items as well.

4. Monte Carlo Simulation

One of the more interesting concepts to come out of our research is how to fund individual ships. For example, if a DDG is extended for a given period, should it be funded at the mean level for the class or some other point on the distribution? By collecting the data from the TYCOMs by hull, we have the data necessary to develop the distribution of costs for a given ship class around the mean. Once determined, the distribution of ships in a class could be incorporated into a Monte Carlo simulation (e.g. Crystal Ball) in order to give the decision maker greater information in managing the risk associated with over-funding (denying resources to other commands) or under-funding (potentially impacting the operational readiness of the ship being extended).

5. Analysis of the Data Input Process

Through multiple methods of analysis, we observed that the price growth factors used in the current model merely added error to the model. The potential exists for future research to develop an accurate means to incorporate price growth factors in the current model.

APPENDIX A: SHIP OPS MODEL EXAMPLE CALCULATIONS

A. APPENDIX DESCRIPTION

This appendix provides a detailed step-by-step review of the calculation of each fund code in the Ship Ops model. This appendix is meant to be a supplement to Chapter II, the narrative description of the same process. As stated in Chapter II, the goal is to describe only those parts of the model that are included in cost prediction. To make the description easier we will use only one Resource Sponsor (RS) and one ship class. The following calculations use data for Pacific Fleet, DDG-51 class ships for the POM-04 cycle. Table 9 provides a helpful list of terms and abbreviations with descriptions for the many elements found in the Ship Ops model.

Following the definitions table, we describe the data fields in the various input sheets pertinent to our chosen program element. The following sections detail the calculation of each cost element such as Fuel (SF), Utilities (SU), Other Consumables (SO), Repair Parts (SR), Counter Terrorism (CT) and No Special Interest items (NSI). Separate worksheets are used in the model to calculate the given cost element. At the top of each table, the name of the worksheet is listed. Fields from the actual worksheets are provided to show how the data are structured in the model. Below the tables the content of each column is discussed, including the data source worksheet and the method of calculation. The other two types of worksheets, Info Sheets and Summary Sheets, are not included in this Appendix. Info Sheets, such as the Model Update Info sheet, simply provide useful additional information to the user, but are not used in cost element calculations. Summary Sheets are used to present the output of the model in various formats. Since we set out to evaluate the model's predictive capabilities we can ignore these sheets for the purposes of this project.

B. USEFUL DEFINITIONS

The first step in deciphering this model is to become familiar with the terms and abbreviations used throughout each worksheet. The table below provides a quick, useful reference for the following sections that describe the actual calculations.

Term/Abbreviation	Definition
APPN	Appropriation
BBLs	Barrels
CL	Claimant
DNUW	Deployed, Not Underway
DUW	Deployed, Underway
FY	Fiscal Year
GOLD DISK	A SR cost savings initiative that works to decrease SR expenditures through unit micro miniature repair of circuit cards and other similar parts
LECP	Logistics Engineering Change Proposal. Program that is run by the Naval Inventory Control Point (NAVICP) Mechanicsburg, PA that predicts savings based on system engineering changes. Data for these constants are provided by NAVICP.
MTIS	Material Turned into Stock. Represents SR cost savings from inventory that has been removed from ships and turned into the retail system. The resource sponsor receives the credit.
NDUW	Not Deployed, Underway
NDNUW	Not Deployed and Not Underway.
PDREP	Product Data Reporting and Evaluation Program. System that collects product quality deficiency and supplier performance data. Projects savings from purchasing quality products with lower reject rates. Savings data provided by claimant.
PE	Program Element
OPMO	Operating Months. Number of months that a ship is available for operations (commissioned, not in repair status)
OMN	Operations and Maintenance Navy
RS	Resource Sponsor
SHIP YRS	Ship Years. Determined by number of ships in the class with partial years for commissioning or decommissioning in that year

Table 20: Helpful Definitions of Model Terms and Abbreviations

C. FEEDER SHEETS

The following tables provide excerpts from the Feeder Sheets pertinent to Pacific Fleet DDG-51 cost element determination. Sheet names are found in the blocks above the tables.

1. OP-41 List

For Pacific Fleet DDG-51 class ships the resource sponsor (RS) is the OPNAV N-76 office (RS = 76 in the model) and the claimant is Commander Pacific Fleet (CL = 70). The OP-41 Feeder Sheet includes the number of ships in the class and the calculated Ship Years based on actual ship status for 1999-2001 and predicted numbers for 2002. It also has the actual cost figures for 1999 and 2000 and the estimated costs for 2001 for each cost element.

[OP-41 List] – [RS=76; CL=70; PE=0204222N; CLASS=DDG-51CL]

[Column] Name / YR [Row]	1999 [501]	2000 [539]	2001 [577]	2002 [615]
[J] Count	13	13	15	17
[K] Ship Years	11.7	13	14	16.25
[L] Op Mos	131.3	142	161	180.7
[M] Fuel (SF)	32,145	24,464	9,094	-
[N] Util (SU)	6,345	6,581	8,441	-
[O] RP (SR)	18,274	19,562	23,462	-
[P] OPTAR (SO)	14,984	8,180	12,763	-
[Q] NSI	849	886	1,113	-
[R] CT	0	0	0	-
[S] Total	72,597	59,673	88,862	-

2. FY-CL-RS Constants

This constants page provides price growths for the cost elements as provided by the Resource Sponsors. The constants for 1999-2001 are actual costs growth and for 2002 the growth is predicted

[FY-CL-RS Constants]

FY-CL-RS	FY	RS	CL	APPN	OPTAR		Repair Parts	NSI/CT
					Price Growth	PDREP	Price Growth	Price Growth
1999 - 70 - 76	1999	76	70	OMN	100.74%	0.9940	95.63%	102.10%
2000 - 70 - 76	2000	76	70	OMN	100.40%	1.0000	98.60%	101.50%
2001 - 70 - 76	2001	76	70	OMN	103.90%	1.0000	111.30%	101.70%
2002 - 70 - 76	2002	76	70	OMN	98.70%	1.0000	98.40%	101.60%

3. FY-CL-Constants

The following two tables show multipliers from the FY-CL Constants sheet provided by the program Claimant used in the determinations of element costs. Historical observations and data are used by the Claimants to determine the multipliers. The 2001 and 2002 BBL prices are estimated based on previous observations and predictions.

[FY-CL Constants]

FY - CL - OMN	Days per Month	Deployed			Non-Deployed		
		DUW/MO Multiplier	Price per BBL	D-not UW/MO Factor	DUW/MO Multiplier	Price per BBL	D-not UW/MO Factor
1999 - 70 - OMN	30.4	1.03700	\$33.60	0.900	1.2000	\$33.60	0.900
2000 - 70 - OMN	30.4	0.88100	\$25.20	0.900	0.9915	\$25.20	0.900
2001 - 70 - OMN	30.4	0.94100	\$41.16	0.900	1.0280	\$41.16	0.900
2002 - 70 - OMN	30.4	0.98339	\$40.32	0.900	0.9982	\$40.32	0.900

FY - CL - OMN	OPTAR	Utilities	Repair Parts				OPTAR	NSI
	Control	Price Growth	Control	MTIS Growth	Gold Disk/PDREP	100% - ICAS Reduction	PDREP	
1999 - 70 - OMN	100.0%	99.40%	100.0%	95.00%	4.70%	66.67%	0.9940	0.0000
2000 - 70 - OMN	100.0%	95.20%	100.0%	95.00%	4.70%	66.67%	1.0000	0.0000
2001 - 70 - OMN	100.0%	100.50%	100.0%	95.00%	3.13%	66.67%	1.0000	0.0000
2002 - 70 - OMN	100.0%	132.60%	100.0%	95.00%	1.57%	66.67%	1.0000	0.0000

4. Burn Rates

[Burn Rates]

RS	CL	PE	Class	OPMO %	Deployed				Non-Deployed				OP Mo %
				FY03	DUW per Mo	UW BURN	DNUW per Mo	NUW BURN	DUW per Mo	UW BURN	DNUW per Mo	NUW BURN	FY04-FY09
76	70	0204222N	DDG-51CL	0.34	19.6	618	10.8	79	9.5	527	20.9	15	0.34

D. CALCULATION SHEETS

1. Fuel (SF)

This is probably the most complex section of the model. The fuel cost calculation method differs significantly from the calculation of the rest of the cost elements. This section is broken down into five subsections. Each shows how the cost is calculated according to the operational status (deployed, non-deployed, underway, not underway) of the ships and the total fuel calculation. Note: Within each calculation description a letter within the () refers to the subsection number. For example, (a) refers to the DUW subsection.

[FUEL (SF)] – [YR=2002; RS=76; CL=70; PE=0204222N; CLASS=DDG-51CL]

a. DUW (Deployed, Underway)

EOY Inventory X	Ship Years X	OPMO X	OPMO %	Calc OPMO X	OP MO	Deployed				Deployed		UW Fuel Cost (\$000) X
						DUW/MO	Adj DUW/MO X	Adj OP-TEMPO	Adj Days UW X	Burn Rate UW/Day (BBL)	UW BBL X	
0	16.25	180.7	34.00%	61.4	0.0	19.6	19.2744	57.8	1,184	618	731,83	29,507

Source & Calculation:

- EOY Inventory X* - Manual correction - Not used here
- Ship Years X* - [OP-41 List]; [Ship Years] Column [K] – used in subsection e.
- OPMO X* - [OP-41 List]; [Op Mos] Column [L]
- OPMO %* - [Burn Rates]; [OPMO %] FY03 Column [F] - Op month % is defined as the percentage of all op months normally spent in a deployed status.
- Calc OPMO X* = [OPMO X] * [OPMO %] - The calculated op months or number of op months normally spent in a deployed status.
- OP MO* - Not used here
- DUW/MO* - [Burn Rates]; [DUW per Mo] Column [G] – Days underway per month (one month = 30.4 days constantly)
- Adj DUW/MO X* = [DUW/MO] * [OPTEMPO multiplier] → [FY-CL Constants]; [DUW/MO Multiplier] Column [E] – Adjustment made by this OPTEMPO multiplier in order to reach OPTEMPO goals
- Adj OPTEMPO* = [Adj. DUW/MO] * 3 – same figure for one quarter
- Adj Days UW X* = [Calc OPMO X] * [Adj DUW/MO] - This is the total deployed days underway.
- Burn Rate UW/Day (BBL)* – [Burn Rates]; [UW BURN] Column [H]
- UW BBL* = [Burn Rate UW/Day (BBL)] * [Adj Days UW X] - Underway barrels.
- UW Fuel Cost (\$000) X* = [UW BBL] * [Price per Barrel]/1,000 → [FY-CL]; [Price per BBL] Column [F] - This is the deployed underway fuel cost The fuel price per barrel from the FY-CL worksheet is multiplied by UW BBL and divided by 1,000.

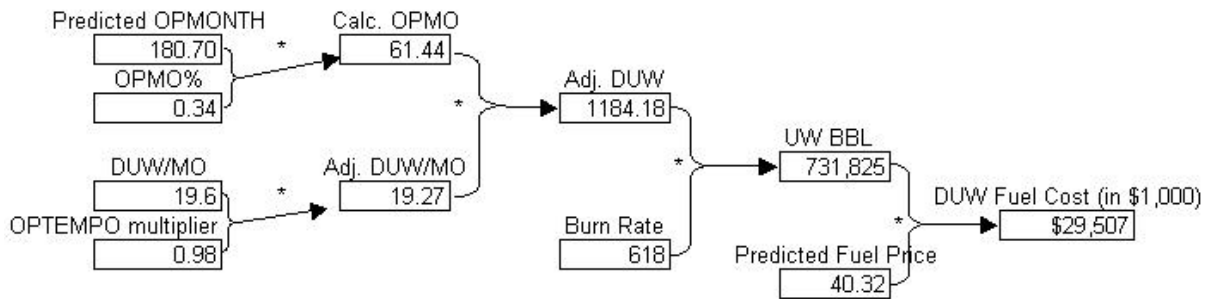

b. DNUW (Deployed, Not Underway)

							Deployed TO-TAL	Deployed TOTAL
Not UW/MO	Adj Not DUW/MO	Adj Days not UW	In port Daily Burn (BBL)	Not UW (BBL)	Not UW Fuel Cost (\$000) X	Cold Iron Days per MO	Total BBLs '000	Total (\$000)
10.8	11.1	684	79.0	53999.06	2,177.24	0.0	785,824.06	31,684.43

Source & Calculation:

Not UW/MO - [Burn Rates]; [DNUW per Mo] Column [I] – Days NOT underway per month = 30.4 – DUW/MO – Not used, just to compare with the next number

Adj Not DUW/MO = 30.4 – Adj DUW/MO (1.)

Adj Days not UW = [Adj Not DUW/MO] * [Calc OPMO X] (subsection a.) - This is the total deployed days NOT underway.

In port Daily Burn (BBL) – [Burn Rates]; [NUW BURN] Column [J]

Not UW (BBL) = [Adj Days not UW] * [In port Daily Burn (BBL)] – Deployed NOT underway barrels

Not UW Fuel Cost (\$000) X = [Not UW BBL] * [Price per Barrel]/1,000 -> [FY-CL]; [Price per BBL] Column [F] - This is the deployed NOT underway fuel cost The fuel price per barrel from the FY-CL worksheet is multiplied by NUW BBL and divided by 1,000 to be in thousands like the other numbers in the table.

Total BBLs '000 & Total (\$000) – Total deployed fuel cost in barrels & in dollars

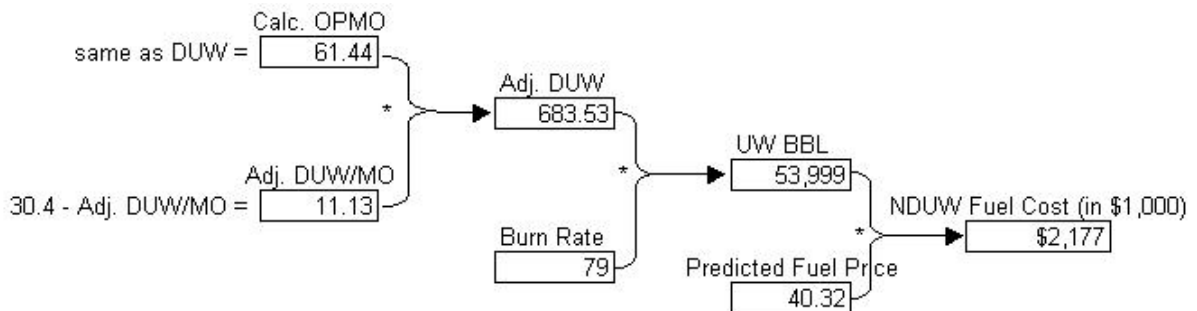

c. NDUW (Not Deployed, Underway)

Not Deployed OPMO	Days UW/MO	Adj Days UW/MO	Adj Total Days UW X	UW Daily Burn Rate	UW BBL X	UW Fuel Cost (\$000) X
119.3	9.5	9.5	1,130.99	527	596,031	24,031.98

Source & Calculation:

Not Deployed OPMO = [OPMO] – [Calc OPMO X] – Months in operation, but not deployed

Days UW/MO - [Burn Rates]; [DUW per Mo] Column [K] – NOT deployed days underway per month

Adj Days UW/MO = [Days UW/MO] * [OPTEMPO multiplier] -> [FY-CL Constants]; [DUW/MO Multiplier] Column [H] – Adjustment made by this OPTEMPO multiplier (1.0009) in order to reach OPTEMPO goals.

Adj Total Days UW X = [Not Deployed OPMO] * [Adj Days UW/MO] - This is the total NOT deployed days underway.

UW Daily Burn Rate - [Burn Rates]; [UW BURN] Column [L] – Non-deployed burn rate

UW BBL X = [Adj Total Days UW X] * [UW Daily Burn Rate] NDUW barrels

UW Fuel Cost (\$000) X = [UW BBL X] * [Price per Barrel]/1,000 -> [FY-CL]; [Price per BBL] Column [I] - This is the NOT deployed underway fuel cost The fuel price per barrel from the FY-CL worksheet is multiplied by UW BBL and divided by 1,000.

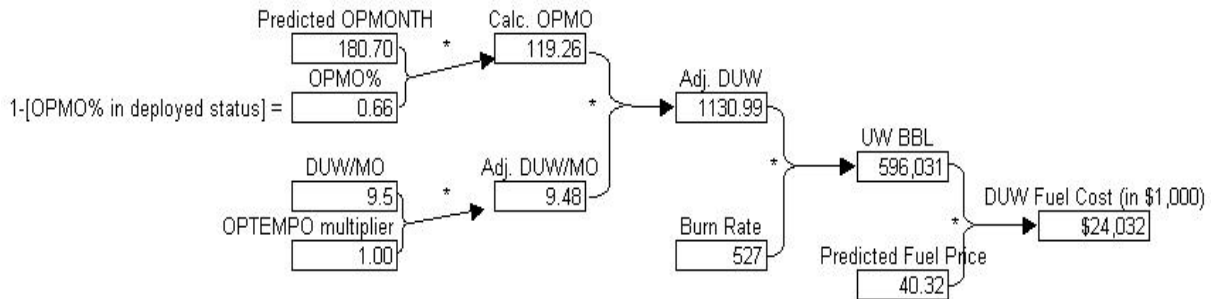

d. NDNW (Not Deployed, Not Underway)

Days not UW/MO	Adj Days not UW/MO	Adj Days not UW Total	Not UW Burn Rate	Not UW BBL X	Not UW BBL (\$000) X	Days Cold Iron	Total BBL X	Total (\$000) X
20.9	20.9	2,494.58	15	37,418.63	1,508.72	0.0	633,450	25,540.70

Source & Calculation:

Days not UW/MO - [Burn Rates]; [DNUW per Mo] Column [M] – Days NOT underway per month = 30.4 – DUW/MO – Not used, just to compare with the next number

Adj Not UW/MO = 30.4 – Adj days UW/MO (subsection c.)

Adj Days not UW Total = [Adj Not UW/MO] * [Not Deployed OPMO] (subsection c.)

Not UW Burn Rate - [Burn Rates]; [NUW BURN] Column [N]

Not UW BBL X = [Adj Days not UW Total] * [Not UW Burn Rate] – NOT deployed NOT underway barrels

Not UW BBL (\$000) X = [Not UW BBL X] * [Price per Barrel]/1,000 -> [FY-CL]; [Price per BBL] Column [I] - This is the NOT deployed NOT underway fuel cost The fuel price per barrel from the FY-CL worksheet is multiplied by NUW BBL X and divided by 1,000.

Total BBL X & Total (\$000) X – Total NOT deployed fuel cost in barrels & in dollars

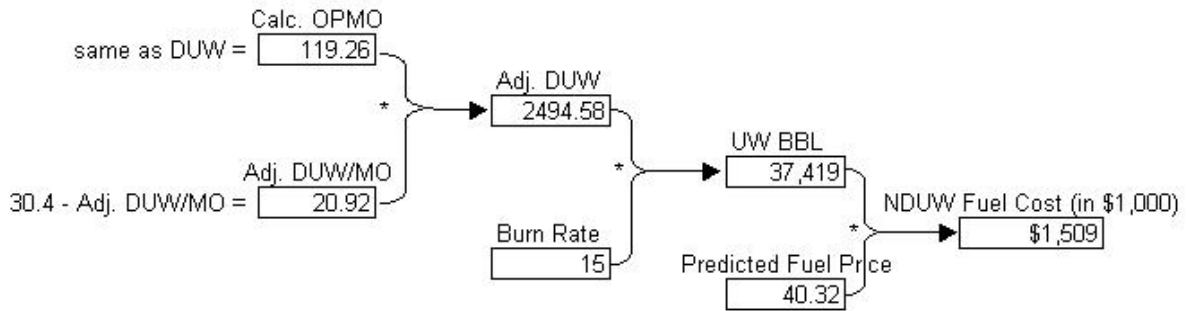

e. Total Fuel Cost

(includes fuel costs incurred for ships in a repair status)

Totals					
Ship Type	Total BBL X	Fuel Total (\$000) X	REPMO	Repair Barrels	REPMO Fuel \$000
DDG-51CL	1,442,836	58,175.14	14.3	23561.8	950.01

Source & Calculation:

Total BBL X = [Total BBLs '000 & Total (\$000)] (subsection b.) + [Total BBL X] (4.) + [Repair Barrels] – total fuel cost in barrels (op+repair)

Fuel Total (\$000) X = [Total (\$000)] (2.) + [Total (\$000) X] (subsection d.) + [REPMO Fuel \$000] - total fuel cost in dollars (op+repair)
 = **DUW + DNUW + NDUW + NDNUW + Repair**

REPMO = [Ship Years X] (1.) * 12 – [OPMO X] (subsection a.) Months in repair status - ship years multiplied with 12 in order to get months commissioned and decreased by operational months

Repair Barrels = [REPMO] * 0.1 * 30.4 * ([UW Daily Burn Rate] (subsection c.) + [Not UW Burn Rate] (subsection d.) – Repair fuel cost in barrels – first a constant adjustment to get adjusted repair days, then, it's multiplied by the average of the NOT deployed burn rates (UW and NUW)

REPMO Fuel \$000 = [Repair Barrels] * [Price per Barrel]/1,000 -> [FY-CL]; [Price per BBL] Column [I] - This is the Repair fuel cost The fuel price per barrel from the FY-CL worksheet is multiplied by Repair Barrels and divided by 1,000 to be in thousands like the other numbers in the table.

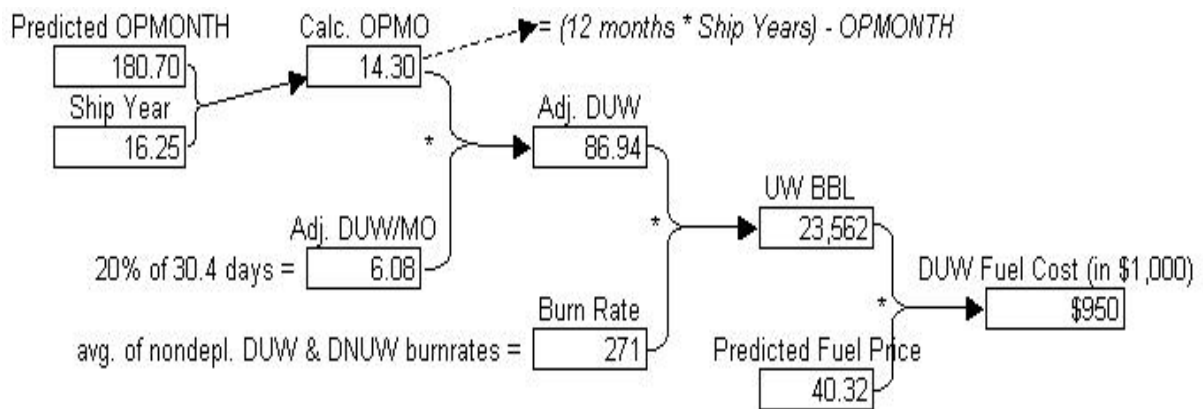

2. Counter Terrorism (CT)

The CT cost element is one of the latest additions to the model.

[Counter Terrorism (CT)] – [YR=2002; RS=76; CL=70; PE=0204222N; CL=DDG-51CL]

FY01 to FY02 Price Growth	Ship Years	Base Total Rqmnt	ATFP Travel	Phased Replacement	Port Visits	Adj Rqmnt
101.60%	16.3	101		0	602	703

FY01 to FY02 Price Growth - [FY-CL-RS Constants]; [NSI/CT Price Growth] Column [I]

Ship Years - [OP-41 List]; [Ship Years] Column [K]

These are not used directly here.

All the other numbers are from manual input.

3. Repair Parts (SR)

This section consists of two subsections that describe the Incremental SR (a manual adjustment to the SR calculation for one time costs) and the SR sheet.

[Incremental SR] - [YR=2002; RS=76; CL=70; PE=0204222N; CLASS=DDG-51CL]

2002					
POM-04 In-crem Rqmnt	AS-39 Delta	SSN21 Delta	Reserve Equity	CEC	Total
0				311	311

Manual inputs. The total number will be used subsequently.

[Repair Parts (SR)] - [YR=2002; RS=76; CL=70; PE=0204222N; CLASS=DDG-51CL]

3 YR AVG FY01 Unit Cost	2002				
	FY01 to FY02 Price Growth	Ship Years	Base Total Rqmnt	Gold Disk	
				1.57% Factor	Savings
1,781	98.40%	16.3	28,483	0.0157	(446)

LECP Savings	Incr Rqmnt	MTIS Savings	Adj Rqmnt
35	311	(662)	27,410

Source & Calculation:

- 3 YR AVG FY01 Unit Cost* - Average of the last three years' SR unit cost adjusted (by appropriate price growths) to FY01 dollars.
- FY01 to FY02 Price Growth* - [FY-CL-RS Constants]; [Repair Parts Price Growth] Column [H] – Row [63] expected price growth for getting FY02 dollars
- Ship Years* - [OP-41 List]; [Ship Years] Column [K]
- Base Total Rqmnt* = [3 YR AVG FY01 Unit Cost] * [FY01 to FY02 Price Growth] * [Ship Years] – Basic requirement in FY02 dollars
- Gold Disk Factor* - [FY-CL Constants]; [Repair Parts Gold Disk/PDREP] Column [O] – appropriate factor by year and fleet (and OMN).
- Gold Disk Savings* = [Base Total Rqmnt] * [Gold Disk Factor] – Savings coming from Gold Disk prg, constant proportion of basic requirement.
- LECP Savings* - manual input
- Incr Rqmnt* - [Incremental SR]; [2002 Total] Column [Q]
- MTIS Savings* - manual input
- Adj Rqmnt* = [Base Total Rqmnt] + [Gold Disk Savings] + [LECP Savings] + [Incr Rqmnt] + [MTIS Savings] – This gives the total repair cost estimate for year 2002 in FY02 dollars

	<i>(Actual SR Cost - Incr.Cost) / Ship Yr</i>			=	<i>SR Unit Cost</i>	*	<i>Actual Price Growths</i>		=	<i>SR Unit Cost in Year-1 dollar</i>
							<i>[Y-3]->[Y-2]</i>	<i>[Y-2]->[Y-1]</i>		
Year-3	\$18,274	-1,171	11.70	=	\$1,662	*	98.60%	111.30%	=	\$1,823.87
Year-2	\$19,562	-1,285	13.00	=	\$1,604	*		111.30%	=	\$1,784.81
Year-1	\$23,462	-831	14.00	=	\$1,735				=	\$1,735.21
										Average: \$1,781.30

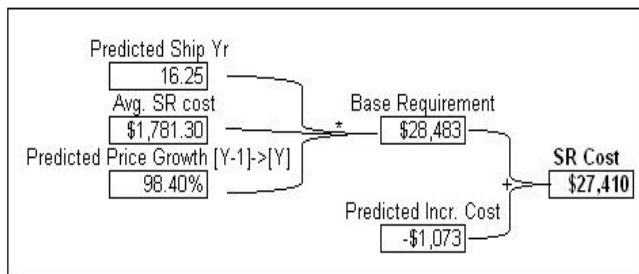

4. Other Consumables (SO)

This section is similar to the previous one, also with two sub-sections having the same function.

[Incremental SO] – [YR=2002; RS=76; CL=70; PE=0204222N; CLASS=DDG-51CL]

2002					
Increm Rqmnt	CBR Medicinals	Sub Force Coil Mat-tress	MEDEVAC	Reserve Ship Equity	Total
164	55		200		419

Manual inputs. The total number will be used subsequently.

[OPTAR (SO)] – [YR=2002; RS=76; CL=70; PE=0204222N; CLASS=DDG-51CL]

3 YR AVG FY01 Unit Cost	2002					
	FY01 to FY02 Price Growth	Ship Years	Base Total Rqmnt	MTIS Savings	Increm Rqmnt	Adj Rqmnt
967	98.70%	16.3	15,511	0	419	15,931

Source & Calculation:

- 3 YR AVG FY01 Unit Cost* - Average of the last three years' SO unit cost adjusted (by appropriate price growths) to FY01 dollars.
- FY01 to FY02 Price Growth* - [FY-CL-RS Constants]; [OPTAR Price Growth] Column [F] – Row [63] expected price growth for getting FY02 dollars
- Ship Years* - [OP-41 List]; [Ship Years] Column [K]
- Base Total Rqmnt* = [3 YR AVG FY01 Unit Cost] * [FY01 to FY02 Price Growth] * [Ship Years] – Basic requirement in FY02 dollars
- MTIS Savings* - manual input
- Increm Rqmnt* - [Incremental SO]; [2002 Total] Column [Q]

Adj Rqmnt

= [Base Total Rqmnt] - [MTIS Savings] + [Incr
Rqmnt]– This gives the total other or “consumable” mate-
rial cost estimate for year 2002 in FY02 dollars

	(Actual SO Cost - Incr.Cost) / Ship Yr	=	SO Unit Cost	*	Actual Price Growths	*	SO Unit Cost in Year-1 dollar	
					$\frac{[Y-3]->[Y-2]}{100.40\%}$		$\frac{[Y-2]->[Y-1]}{103.90\%}$	
Year-3	\$14,984 / 0 = 11.70	=	\$1,281	*	100.40%	*	\$1,335.95	
Year-2	\$8,180 / 0 = 13.00	=	\$629	*	103.90%	*	\$653.77	
Year-1	\$12,763 / 0 = 14.00	=	\$912				\$911.64	
							Average:	\$967.12

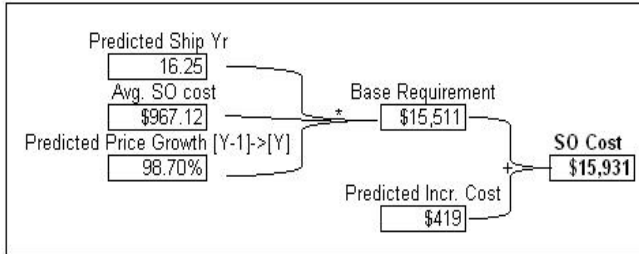

5. Utilities

[Utilities (SU)] – [YR=2002; RS=76; CL=70; PE=0204222N; CLASS=DDG-51CL]

3 YR AVG FY00 Unit Cost	2002		
	FY01 to FY02 Price Growth	Op Months	Rqmnt
48	132.60%	181	11,612

Source & Calculation:

3 YR AVG FY01 Unit Cost - Average of the last three years’ SU unit cost adjusted (by appropriate price growths) to FY01 dollars.

FY01 to FY02 Price Growth - [FY-CL Constants]; [Utilities Price Growth] Column [L] – Row [43] expected price growth for getting FY02 dollars

Op Months - [OP-41 List]; [Op Mos] Column [L] – planned operational months for year 2002

Rqmnt = [3 YR AVG FY01 Unit Cost] * [FY01 to FY02 Price Growth] * [Op Months] – This gives the total utilities cost estimate for year 2002 in FY02 dollars

	Actual SU Cost	Actual OPMONTH	SU Unit Cost	Actual Price Growths	SU Unit Cost in Year-1 dollar	
				[Y-3]->[Y-2]	[Y-2]->[Y-1]	
Year-3	\$6,345	131.3	\$48	95.20%	100.50%	
Year-2	\$6,581	142	\$46		100.50%	
Year-1	\$8,441	160.56	\$53			
					Average:	\$48.46

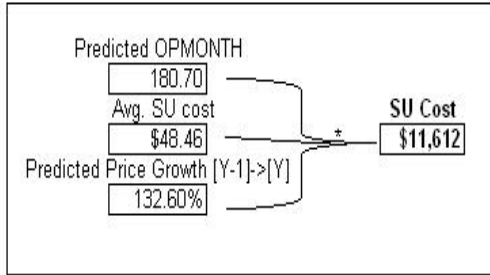

6. No Special Interest Items (NSI)

Another recent cost element addition to the model.

[NSI (000000)]-[YR=2002; RS=76; CL=70; PE=0204222N; CLASS=DDG-51CL]

3 YR AVG FY01 Unit Cost	2002							
	FY01 to FY02 Price Growth	Ship Years	Base Total Rqmnt	NMCI	CIVPE RS	CMD STAFF	TADTAR	Adj Rqmnt
75	101.60%	16.3	1,234	0	0	0	0	1,234

Source & Calculation:

Base requirement calculated from the three years' average NSI unit costs, adjusted to FY01 dollars, than multiplied by the growth rate (same as CT's one - [FY-CL-RS Constants]; [NSI/CT Price Growth] Column [I]) and by Ship Years ([OP-41 List]; [Ship Years] Column [K]).

Adjusted requirement is then coming form the sum of base requirements and adjustments (manual inputs).

THIS PAGE INTENTIONALLY LEFT BLANK

APPENDIX B: CURRENT MODEL ANALYSIS METHODOLOGY

This appendix contains the details on our analysis of the original model. For each of the five selected ship classes it lists the following data:

- (1) *Appraisal of Model Accuracy* table contains the cost that actually occurred and the PFAD costs, the calculated absolute and relative (proportioned to the actual value) differences and relevant MAPE figures for the certain ship class.
- (2) *Graphs* depict SII and total differences in various decompositions.
- (3) *Appraisal of prediction for 2002* shows the detailed calculations used for conducting a full analysis on the original model capability to predict various cost elements. Moreover here we show a visual presentation of calculating Predicted and PFAD figures for year 2002 in order to make our calculations and analysis more transparent.

Primary and Calculated Inputs tables finally summarize the source data we used in our analysis for the certain ship class. It helped us to identify typos and/or unusual inputs as well.

Fleet	PacFleet
Ship Class	DDG-51CL
Program Element	0204222N
OMN/OMNR	OMN
Resource Sponsor (new)	76
Resource Sponsor (old)	86

Appraisal of Model Accuracy

using backcast: 1997-2002

	Year	SF	SU	SR	SO	Total
Actuals	1997	\$24,654	\$4,315	\$12,748	\$6,626	\$48,343
	1998	\$29,890	\$5,853	\$15,300	\$9,046	\$60,089
	1999	\$32,145	\$6,345	\$18,274	\$14,984	\$71,748
	2000	\$24,464	\$6,581	\$19,562	\$8,180	\$58,787
	2001	\$43,083	\$8,441	\$23,462	\$12,763	\$87,749
	2002	\$47,841	\$12,553	\$23,849	\$11,147	\$95,390
Predicted from All Actual Data	1997	\$23,854	\$3,595	\$15,861	\$9,572	\$52,882
	1998	\$29,608	\$4,372	\$23,814	\$10,056	\$67,849
	1999	\$34,535	\$5,894	\$18,735	\$11,410	\$70,573
	2000	\$11,228	\$6,403	\$19,250	\$12,875	\$49,756
	2001	\$47,991	\$7,651	\$23,320	\$13,551	\$92,513
	2002	\$54,834	\$11,251	\$28,498	\$15,660	\$110,242
Actual - Pred. Fr Actual	1997	\$800	\$720	-\$3,113	-\$2,946	-\$4,539
	1998	\$282	\$1,481	-\$8,514	-\$1,010	-\$7,760
	1999	-\$2,390	\$451	-\$461	\$3,574	\$1,175
	2000	\$13,236	\$178	\$312	-\$4,695	\$9,031
	2001	-\$4,908	\$790	\$142	-\$788	-\$4,764
	2002	-\$6,993	\$1,302	-\$4,649	-\$4,513	-\$14,852
Actual - Pred. Fr Actual Actual	1997	3.24%	16.69%	-24.42%	-44.46%	-9.39%
	1998	0.94%	25.30%	-55.64%	-11.16%	-12.91%
	1999	-7.43%	7.11%	-2.52%	23.85%	1.64%
	2000	54.10%	2.70%	1.59%	-57.40%	15.36%
	2001	-11.39%	9.36%	0.60%	-6.17%	-5.43%
	2002	-14.62%	10.37%	-19.49%	-40.48%	-15.57%
MAPE* =		15.29%	11.92%	17.38%	30.59%	10.05%

* Mean Absolute Percentage Error (avg of the abs value of errors %)

** SF's MAPE without year 2000 = **7.53%**

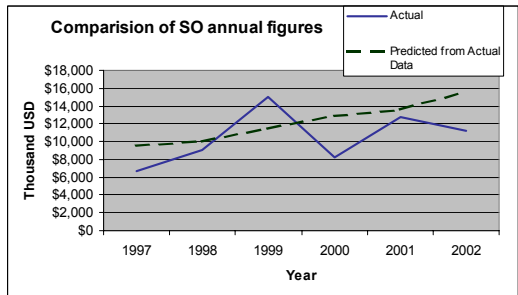
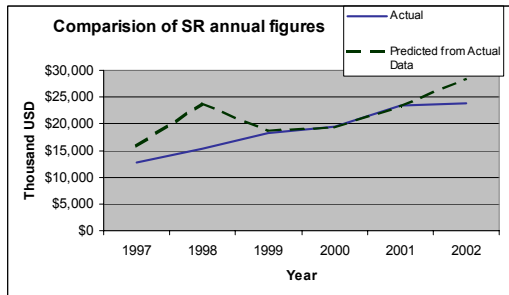
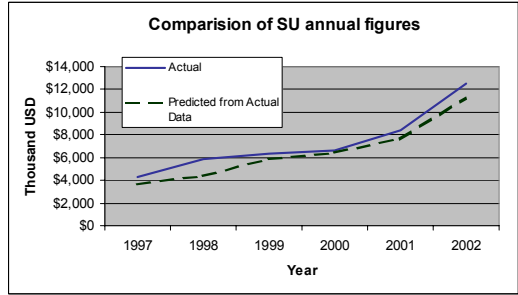
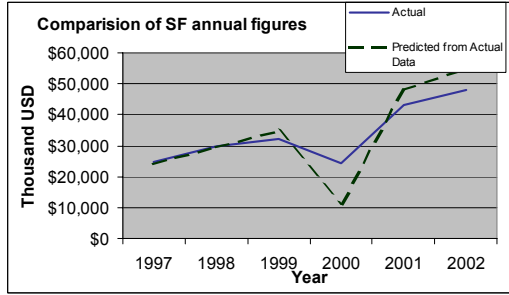
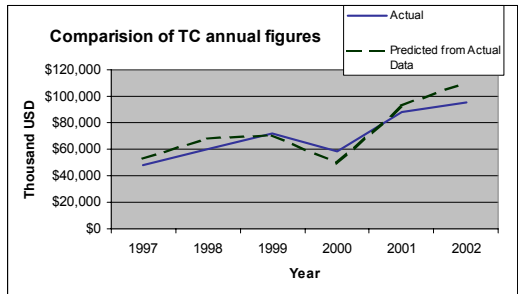
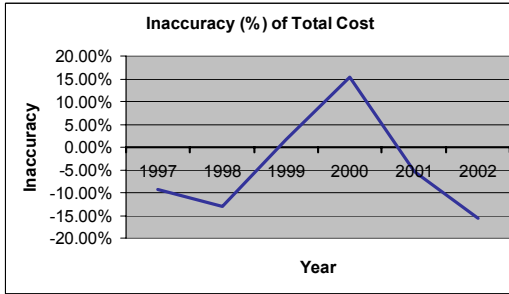
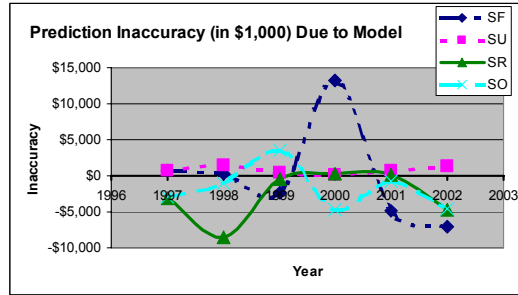
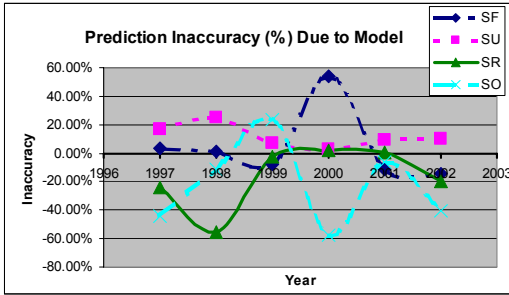

Appraisal of prediction for 2002

Inputs:		PacFleet
Fleet		DDG-51CL
Ship Class		0204222N
Program Element		OMN/OMNR
Resource Sponsor (new)		76
Resource Sponsor (old)		86

	SF	SU	SR	SO	Total
Actual	\$47,841	\$12,553	\$23,849	\$11,147	\$95,390
Predicted	\$58,175	\$11,612	\$27,410	\$15,931	\$113,128
Predicted from All Actual Data	\$54,834	\$11,251	\$28,498	\$15,660	\$110,242
Actual - Predicted	-\$10,334	\$941	-\$3,561	-\$4,784	-\$17,738
- Pred. fr Actual - Predicted	-\$3,342	-\$361	\$1,088	-\$271	-\$2,886
- Actual - Pred. Fr Actual	-\$6,993	\$1,302	-\$4,649	-\$4,513	-\$14,852

-18.60% -> model total inaccuracy
 -3.03% -> source data inaccuracy
 -15.57% -> model inaccuracy

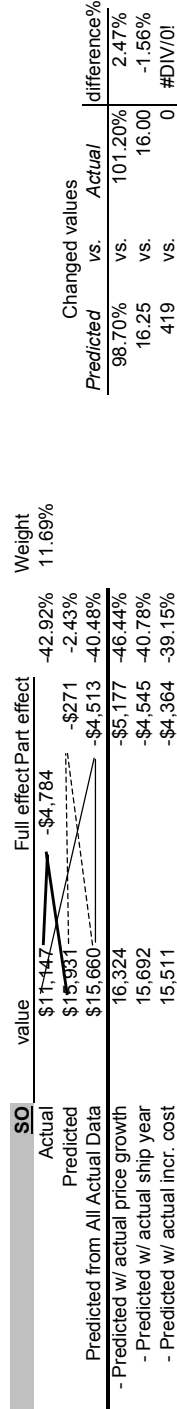
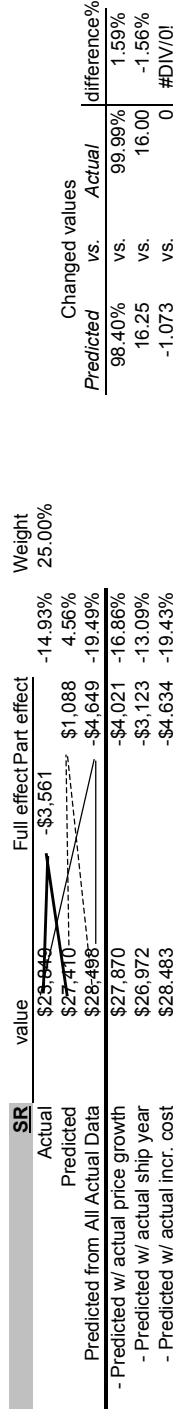
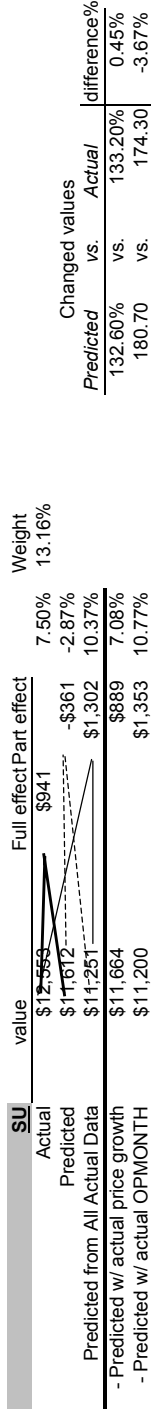
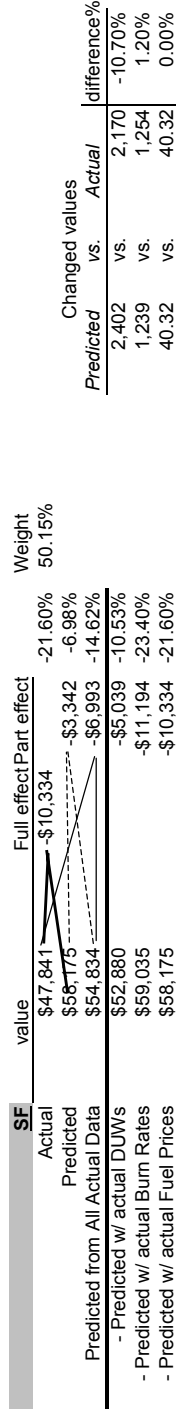

How is predicted value calculated for 2002?

SF

Deployed:

DUW

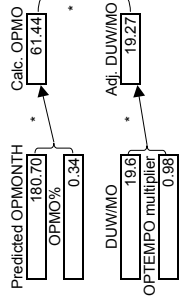

DNUW

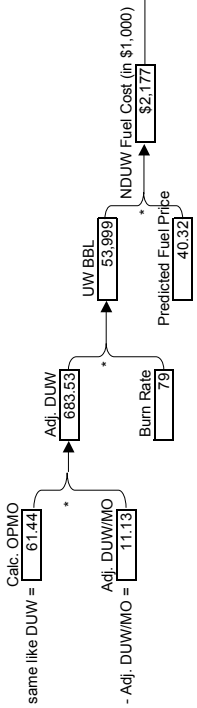

Not Deployed:

DUW

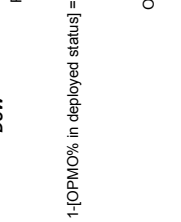

DNUW

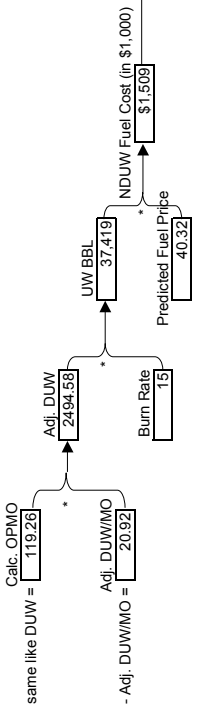

Repair:

Calc. OPMO = (12 months * Ship Years) - OPMONTH

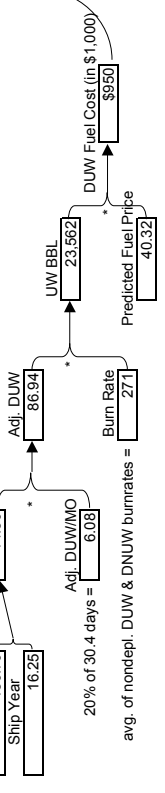

SF Cost \$66,175

SU

	Actual SU Cost	Actual OPMONTH	SU Unit Cost	Actual Price Growths	SU Unit Cost in Year-1 dollar
Year-3	\$6,345	131.3	\$48	95.20% [Y-3]>[Y-2]	\$46.23 [Y-2]>[Y-1]
Year-2	\$6,681	142	\$46		\$46.58 [Y-2]>[Y-1]
Year-1	\$8,441	160.56	\$53		\$52.57 [Y-2]>[Y-1]
					Average: \$48.46

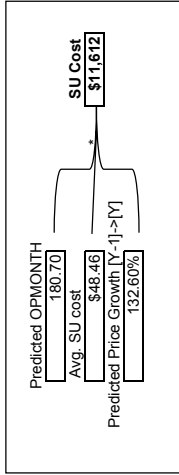

SR

	(Actual SR Cost - Incr. Cost) / Ship Yr	SR Unit Cost	Actual Price Growths	SR Unit Cost in Year-1 dollar
Year-3	\$18,274 - 1,171 / 11.70	\$1,662	98.60% [Y-3]>[Y-2]	\$1,823.87 [Y-2]>[Y-1]
Year-2	\$19,562 - 1,285 / 13.00	\$1,604		\$1,784.81 [Y-2]>[Y-1]
Year-1	\$23,462 - 831 / 14.00	\$1,735		\$1,735.21 [Y-2]>[Y-1]
				Average: \$1,781.30

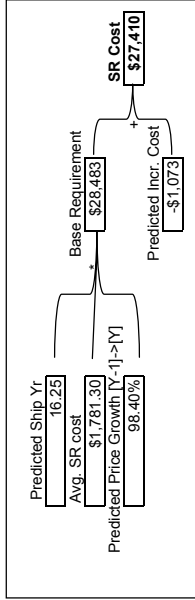

SO

	(Actual SO Cost - Incr. Cost) / Ship Yr	SO Unit Cost	Actual Price Growths	SO Unit Cost in Year-1 dollar
Year-3	\$14,984 - 0 / 11.70	\$1,281	100.40% [Y-3]>[Y-2]	\$1,335.95 [Y-2]>[Y-1]
Year-2	\$8,180 - 0 / 13.00	\$629		\$653.77 [Y-2]>[Y-1]
Year-1	\$12,763 - 0 / 14.00	\$912		\$911.64 [Y-2]>[Y-1]
				Average: \$867.12

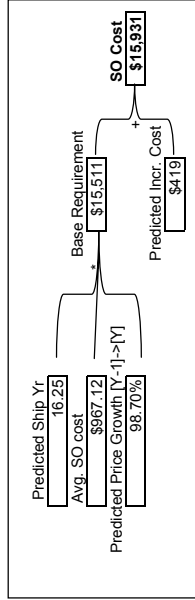

How is predicted value from actual data calculated for 2002?

SF

Deployed:

DUW

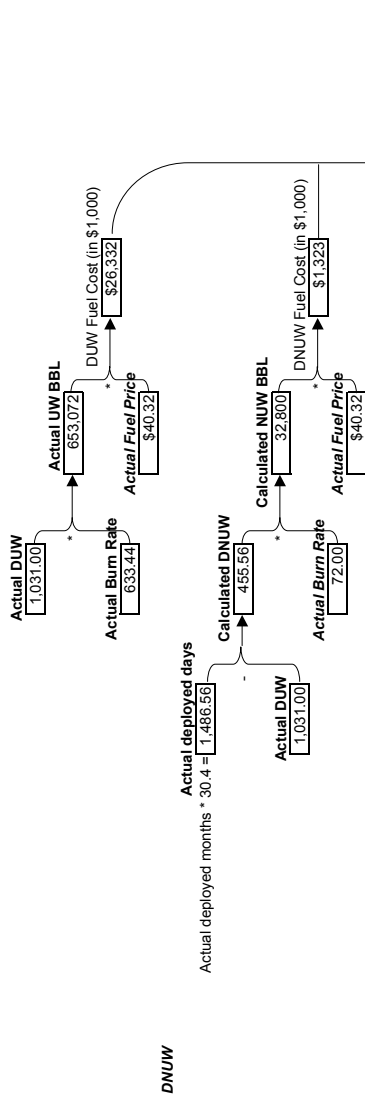

Not Deployed:

DUW

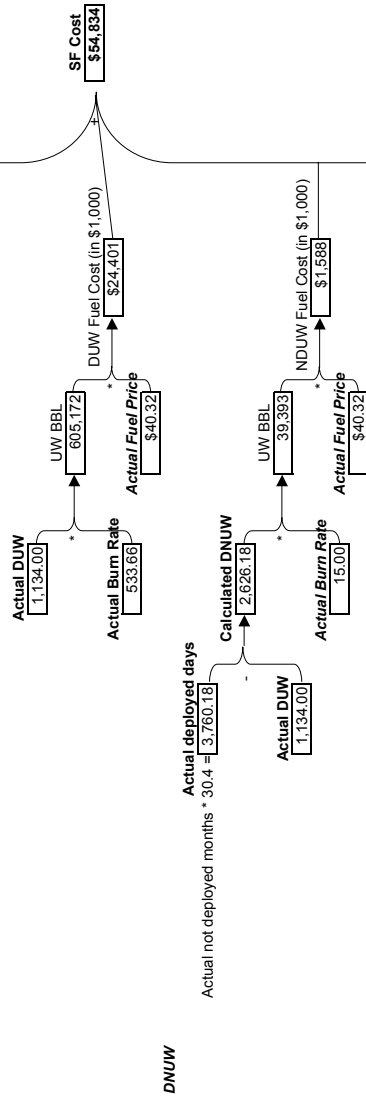

Repair:

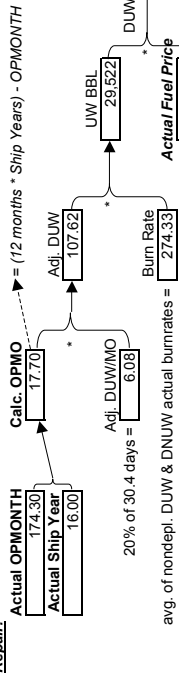

SF Cost \$54,834

SU

	Actual SU Cost	Actual OPMONTH	SU Unit Cost	Actual Price Growths [Y-3]->[Y-2]	Actual Price Growths [Y-2]->[Y-1]	SU Unit Cost in Year-1 dollar
Year-3	\$6,345	/ 131.3	= \$48	* 95.20%	* 100.50%	= \$46.23
Year-2	\$6,581	/ 142	= \$46	*	*	= \$46.58
Year-1	\$8,441	/ 160.56	= \$53			= \$52.57
						Average: \$48.46

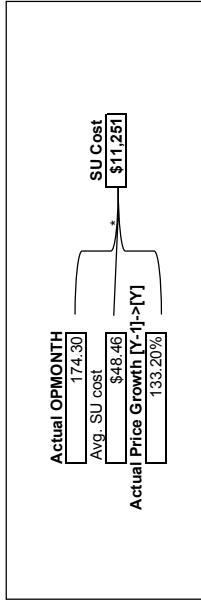

SR

	(Actual SR Cost - Incr.Cost) / Ship Yr	SR Unit Cost	Actual Price Growths [Y-3]->[Y-2]	Actual Price Growths [Y-2]->[Y-1]	SR Unit Cost in Year-1 dollar
Year-3	\$18,274 / -1,171	= 11.70	* 98.60%	* 111.30%	= \$1,823.87
Year-2	\$19,562 / -1,285	= 13.00	*	*	= \$1,784.81
Year-1	\$23,462 / -831	= 14.00			= \$1,735.21
					Average: \$1,761.30

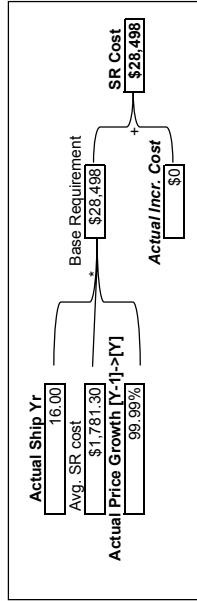

SO

	(Actual SO Cost - Incr.Cost) / Ship Yr	SO Unit Cost	Actual Price Growths [Y-3]->[Y-2]	Actual Price Growths [Y-2]->[Y-1]	SO Unit Cost in Year-1 dollar
Year-3	\$14,984 / 0	= 11.70	* 100.40%	* 103.90%	= \$1,335.95
Year-2	\$8,180 / 0	= 13.00	*	*	= \$653.77
Year-1	\$12,763 / 0	= 14.00			= \$911.64
					Average: \$967.12

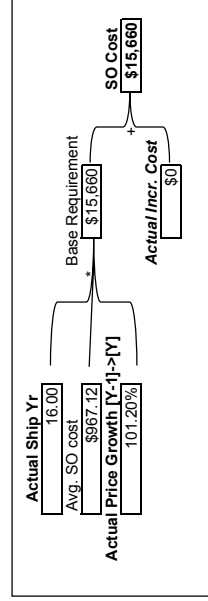

Inputs:
Fleet PacFleet
Ship Class DDG-51CL
Program Element 020422N
OMN/OMNR OMN
Resource Sponsor (new) 76
Resource Sponsor (old) 86

PRIMARY INPUTS

Actual Data	1994	1995	1996	1997	1998	1999	2000	2001	2002
SF	\$7,093	\$0	\$17,360	\$24,654	\$29,890	\$32,145	\$24,464	\$43,083	\$47,841
SU	\$641	\$1,449	\$3,623	\$4,315	\$5,853	\$6,345	\$6,581	\$8,441	\$12,553
SR	\$2,059	\$8,128	\$11,426	\$12,748	\$15,300	\$18,274	\$19,562	\$23,462	\$23,849
SO	\$2,086	\$2,765	\$8,029	\$6,626	\$9,046	\$14,984	\$8,180	\$12,763	\$11,147
Total Cost	\$11,879	\$12,342	\$40,438	\$48,343	\$60,089	\$71,748	\$58,787	\$87,749	\$95,390
Ship Year	1.80	3.60	7.40	9.00	10.40	11.70	13.00	14.00	16.00
OPMONTH	22.00	39.00	85.00	100.90	111.00	131.30	142.00	160.56	174.30
OPMO%	N/A	N/A	N/A	0.37	0.37	0.36	0.32	0.34	0.28
Depl. DUW/MO	N/A	N/A	N/A	18.96	17.94	19.01	17.78	18.24	21.08
Depl. OPTEMPO multiplier	N/A	N/A	N/A	1.09	1.03	1.10	1.03	1.05	1.22
Depl. DUW Burn Rate	N/A	N/A	N/A	572	594	626	251	620	633
Depl. DNUW Burn Rate	N/A	N/A	N/A	72	72	72	72	72	72
Depl. Fuel Price	N/A	N/A	N/A	\$31.08	\$36.96	\$33.60	\$25.20	\$41.16	\$40.32
Not Depl. DUW/MO	N/A	N/A	N/A	8.97	7.62	9.11	8.25	8.83	9.17
Not Depl. OPTEMPO multiplier	N/A	N/A	N/A	0.96	0.82	0.98	0.88	0.95	0.98
Not Depl. DUW Burn Rate	N/A	N/A	N/A	532	483	511	216	533	534
Not Depl. DNUW Burn Rate	N/A	N/A	N/A	75	75	75	75	75	75
Not Depl. Fuel Price	N/A	N/A	N/A	\$31.08	\$36.96	\$33.60	\$25.20	\$41.16	\$40.32
SU Price Growth	N/A	98.80%	98.80%	99.18%	97.30%	99.40%	95.20%	100.50%	133.20%
SR Price Growth	N/A	103.11%	98.87%	107.52%	113.95%	95.63%	98.60%	111.30%	99.99%
SR Incremental Cost	\$0	-\$1,054	-\$952	-\$1,430	-\$225	-\$1,171	-\$1,285	-\$631	\$0
SO Price Growth	N/A	103.11%	98.87%	105.45%	108.19%	100.74%	100.40%	103.90%	101.20%
SO Incremental Cost	\$0	\$0	\$0	\$0	\$0	\$0	\$0	\$0	\$0

~ from OP-41 List
 ~ from OP-41 List
 ~ from OP-41 List
 ~ from OP-41 List
 ~ sum row
 ~ from OP-41 List
 ~ from OP-41 List
 ~ determined from calculated inputs,
 ~ informative data, not used
 ~ determined from calculated inputs,
 ~ informative data, not used
 ~ determined from calculated inputs,
 ~ informative data, not used
 ~ calculated from NUJERS data
 ~ calculated from NUJERS data??
 ~ from the model (FY-CL sheet),
 ~ same as predicted (fixed)
 ~ determined from calculated inputs,
 ~ informative data, not used
 ~ determined from calculated inputs,
 ~ informative data, not used
 ~ calculated from NUJERS data
 ~ calculated from NUJERS data??
 ~ from the model (FY-CL sheet),
 ~ same as predicted (fixed)
 ~ from the model (FY-CL sheet)
 ~ from the model (FY-CL-RS sheet)
 ~ from the model (Incremental SR
 sheet)
 ~ from the model (FY-CL-RS sheet)
 ~ from the model (Incremental SO
 sheet)

Predicted Data	1994	1995	1996	1997	1998	1999	2000	2001	2002	
SF	N/A	N/A	N/A	\$24,973	\$32,488	\$38,613	\$11,937	\$52,374	\$58,175	prediction based on the model's methodology
SU	N/A	N/A	N/A	\$3,595	\$4,619	\$5,880	\$6,075	\$7,735	\$11,612	prediction based on the model's methodology
SR	N/A	N/A	N/A	\$15,861	\$23,814	\$19,111	\$19,216	\$21,125	\$27,410	prediction based on the model's methodology
SO	N/A	N/A	N/A	\$9,572	\$10,056	\$11,535	\$12,651	\$13,307	\$15,931	prediction based on the model's methodology
Total Cost	N/A	N/A	N/A	\$54,001	\$70,977	\$75,140	\$49,879	\$94,542	\$113,128	sum row
Ship Year	N/A	N/A	N/A	9.00	10.40	11.90	13.00	14.00	16.25	from different OP-41 Lists
OPMONTH	N/A	N/A	N/A	100.90	111.00	131.00	136.00	160.56	180.70	from different OP-41 Lists
OPMO%	N/A	N/A	N/A	0.34	0.34	0.34	0.34	0.34	0.34	from different models (Burn Rate sheet)
Depl. DUW/MO	N/A	N/A	N/A	19.6	19.6	19.6	19.6	19.6	19.6	from different models (Burn Rate sheet)
Depl. OPTEMPO multiplier	N/A	N/A	N/A	1.00	0.90	1.04	0.88	0.94	0.98	from different models (FY-CL sheet)
Depl. DUW Burn Rate	N/A	N/A	N/A	572	594	626	251	620	618	from different models (Burn Rate sheet)
Depl. DNUW Burn Rate	N/A	N/A	N/A	79	79	79	79	79	79	from different models (Burn Rate sheet)
Depl. Fuel Price	N/A	N/A	N/A	\$31.08	\$36.96	\$33.60	\$25.20	\$41.16	\$40.32	from different models (FY-CL sheet)
Not Depl. DUW/MO	N/A	N/A	N/A	9.5	9.5	9.5	9.5	9.5	9.5	from different models (Burn Rate sheet)
Not Depl. OPTEMPO multiplier	N/A	N/A	N/A	1.06	1.20	1.20	0.99	1.03	1.00	from different models (FY-CL sheet)
Not Depl. DUW Burn Rate	N/A	N/A	N/A	532	483	511	216	533	527	from different models (Burn Rate sheet)
Not Depl. DNUW Burn Rate	N/A	N/A	N/A	15	15	15	15	15	15	from different models (Burn Rate sheet)
Not Depl. Fuel Price	N/A	N/A	N/A	\$31.08	\$36.96	\$33.60	\$25.20	\$41.16	\$40.32	from different models (FY-CL sheet)
SU Price Growth	N/A	N/A	N/A	99.18%	102.80%	99.40%	94.30%	101.60%	132.60%	from different models (FY-CL-RS sheet)
SR Price Growth	N/A	N/A	N/A	107.52%	113.95%	95.63%	98.00%	101.60%	98.40%	from different models (FY-CL-RS sheet)
SR Incremental Cost	N/A	N/A	N/A	-\$1,430	-\$225	-\$1,135	-\$1,194	-\$921	-\$1,073	from different models (Incremental SR sheet)
SO Price Growth	N/A	N/A	N/A	105.45%	108.19%	100.74%	98.65%	101.74%	98.70%	from different models (FY-CL-RS sheet)
SO Incremental Cost	N/A	N/A	N/A	\$0	\$0	-\$70	\$0	\$38	\$419	from different models (Incremental SO sheet)

CALCULATED INPUTS

	1994	1995	1996	1997	1998	1999	2000	2001	2002
Actual Data									
Deployed Months	0.00	5.79	13.46	37.24	40.64	47.61	45.51	55.00	48.90
Not-Deployed Months	20.39	39.21	73.54	63.12	77.14	81.99	90.26	96.17	123.69
Maintenance Months	0.66	0.00	0.00	0.66	0.49	0.33	0.99	0.16	0.82
Deployed Days Underway	0.00	127.00	319.00	706.00	729.00	905.00	809.00	1,003.00	1,031.00
Deployed Days Not-underway	0.00	49.02	90.18	426.10	506.46	542.34	574.50	669.00	455.56
Not-Deployed Days Underway	218.00	403.00	634.00	566.00	588.00	747.00	745.00	849.00	1,134.00
Not-Deployed Days Not-Underway	401.86	788.98	1,601.62	1,352.85	1,757.06	1,745.50	1,998.90	2,074.57	2,626.18

~ derived from NUERS data
 ~ derived from NUERS data
 ~ derived from NUERS data
 ~ derived from NUERS data
 ~ = (Deployed Months * 30.4 days) -
 ~ Depl. Days Underway
 ~ derived from NUERS data
 ~ = (Not-Deployed Months * 30.4
 ~ days) - Not-Depl. Days Underway

	1994	1995	1996	1997	1998	1999	2000	2001	2002
Predicted Data									
Deployed Months	N/A	N/A	N/A	34.31	37.74	44.54	46.24	54.59	61.44
Not-Deployed Months	N/A	N/A	N/A	66.59	73.26	86.46	89.76	105.97	119.26
Maintenance Months	N/A	N/A	N/A	7.10	13.80	11.80	20.00	7.44	14.30
Deployed Days Underway	N/A	N/A	N/A	671.73	665.73	905.28	798.45	1,006.84	1,184.18
Deployed Days Not-underway	N/A	N/A	N/A	371.18	481.56	448.73	607.24	652.70	683.53
Not-Deployed Days Underway	N/A	N/A	N/A	673.13	835.16	985.64	845.47	1,034.90	1,130.99
Not-Deployed Days Not-Underway	N/A	N/A	N/A	1,351.33	1,391.94	1,642.74	1,883.23	2,186.58	2,494.58

~ = OPMONTH * OPMO%
 ~ = OPMONTH * (1-OPMO%)
 ~ = (Ship Year * 12) - OPMONTH
 ~ = Deployed Months * Depl.
 ~ DUW/MO * Depl. OPTEMPO
 ~ = Deployed Months * (30.4 - (Depl.
 ~ DUW/MO * Depl. OPTEMPO))
 ~ = Not-Deployed Months * Not-
 ~ Depl. DUW/MO * Not-Depl.
 ~ OPTEMPO
 ~ = Not-Deployed Months * (30.4 -
 ~ (Not-Depl. DUW/MO * Not-Depl.
 ~ OPTEMPO))

- missing data, temporary substituted by predicted/actual/previous data
 - calculated value, used for comparison, but not directly in the model

Marked
Italic

Fleet	PacFleet
Ship Class	CG-47CL
Program Element	0204221N
OMN/OMNR	OMN
Resource Sponsor (new)	76
Resource Sponsor (old)	86

Appraisal of Model Accuracy
using backcast: 1997-2002

	Year	SF	SU	SR	SO	Total
Actuals	1997	\$37,162	\$8,902	\$26,353	\$9,532	\$81,949
	1998	\$47,709	\$9,814	\$27,573	\$14,222	\$99,318
	1999	\$41,010	\$8,055	\$28,602	\$16,388	\$94,055
	2000	\$29,459	\$8,821	\$35,726	\$11,307	\$85,313
	2001	\$47,147	\$8,736	\$35,017	\$13,333	\$104,233
	2002	\$52,283	\$12,838	\$32,843	\$12,106	\$110,070
Predicted from All Actual Data	1997	\$39,843	\$8,004	\$25,933	\$13,490	\$87,271
	1998	\$45,241	\$8,623	\$32,882	\$13,298	\$100,044
	1999	\$45,189	\$8,810	\$29,859	\$12,422	\$96,280
	2000	\$14,422	\$8,522	\$29,016	\$13,756	\$65,716
	2001	\$50,710	\$8,898	\$35,075	\$14,596	\$109,280
	2002	\$61,076	\$10,936	\$37,424	\$14,227	\$123,663
Actual - Pred. Fr Actual	1997	-\$2,681	\$898	\$420	-\$3,958	-\$5,322
	1998	\$2,468	\$1,191	-\$5,309	\$924	-\$726
	1999	-\$4,179	-\$755	-\$1,257	\$3,966	-\$2,225
	2000	\$15,037	\$299	\$6,710	-\$2,449	\$19,597
	2001	-\$3,563	-\$162	-\$58	-\$1,263	-\$5,047
	2002	-\$8,793	\$1,902	-\$4,581	-\$2,121	-\$13,593
Actual - Pred. Fr Actual Actual	1997	-7.21%	10.08%	1.59%	-41.52%	-6.49%
	1998	5.17%	12.13%	-19.26%	6.50%	-0.73%
	1999	-10.19%	-9.38%	-4.39%	24.20%	-2.37%
	2000	51.04%	3.39%	18.78%	-21.66%	22.97%
	2001	-7.56%	-1.86%	-0.17%	-9.47%	-4.84%
	2002	-16.82%	14.81%	-13.95%	-17.52%	-12.35%
MAPE* =		16.33%	8.61%	9.69%	20.15%	8.29%

* Mean Absolute Percentage Error (avg of the abs value of errors %)

** SF's MAPE without year 2000 = **9.39%**

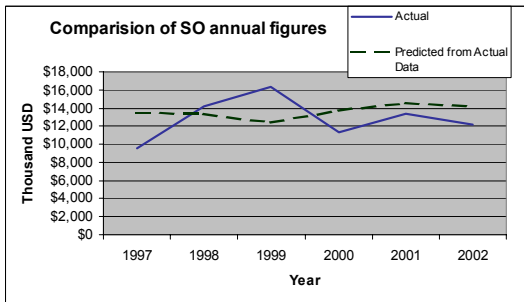
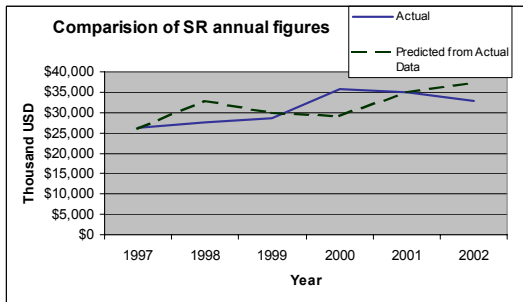
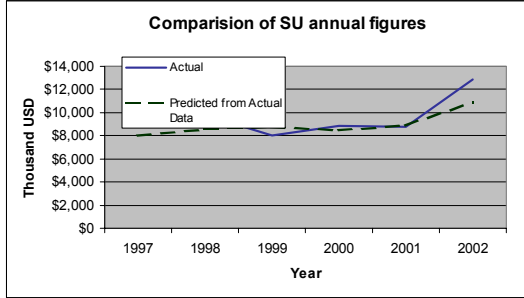
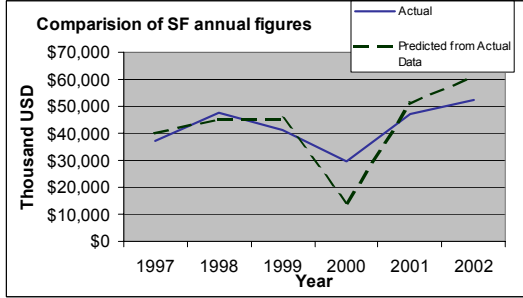
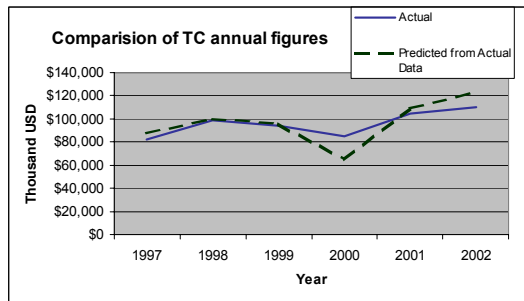
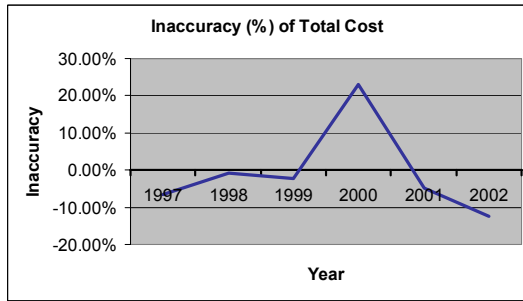
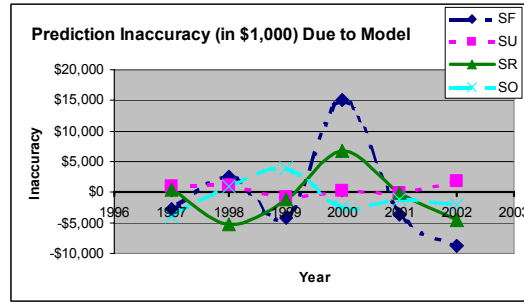
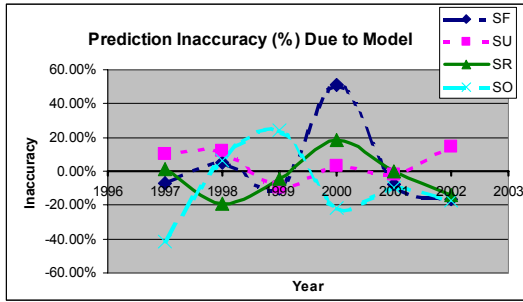

Appraisal of prediction for 2002

Inputs:	PacFleet
Fleet	CG-47CL
Ship Class	0204221N
Program Element	OMN/OMNR
Resource Sponsor (new)	76
Resource Sponsor (old)	86

	SF	SU	SR	SO	Total
Actual	\$52,283	\$12,838	\$32,843	\$12,106	\$110,070
Predicted	\$52,289	\$10,952	\$35,455	\$14,247	\$112,943
Predicted from All Actual Data	\$61,076	\$10,936	\$37,424	\$14,227	\$123,663
Actual - Predicted	-\$6	\$1,886	-\$2,612	-\$2,141	-\$2,873
- Pred. fr Actual - Predicted	\$8,787	-\$16	\$1,968	-\$20	\$10,720
- Actual - Pred. Fr Actual	-\$8,793	\$1,902	-\$4,581	-\$2,121	-\$13,593

-2.61% -> model total inaccuracy
 9.74% -> source data inaccuracy
 -12.35% -> model inaccuracy

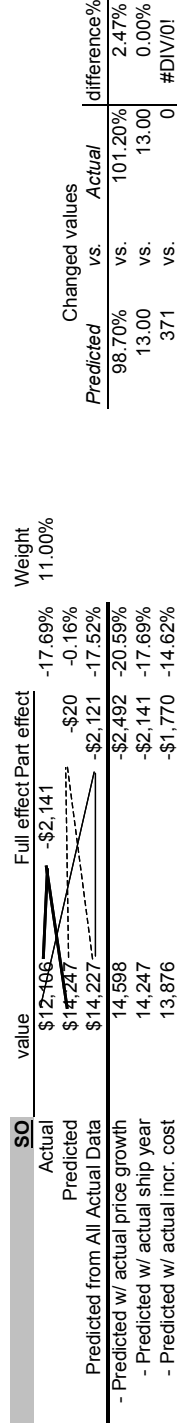
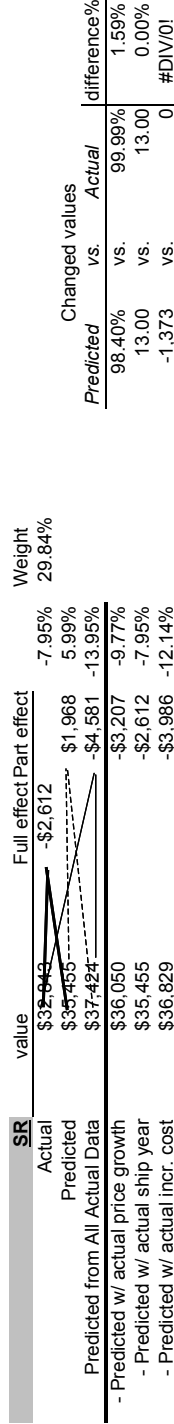
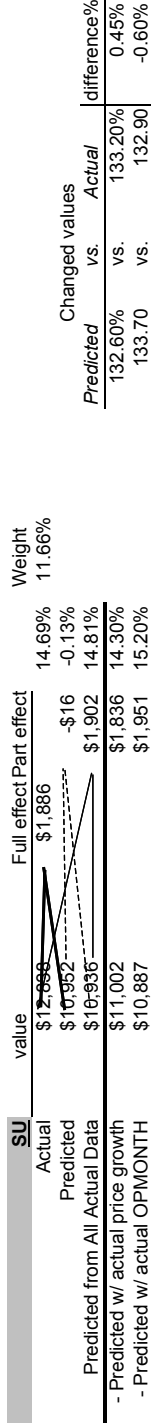
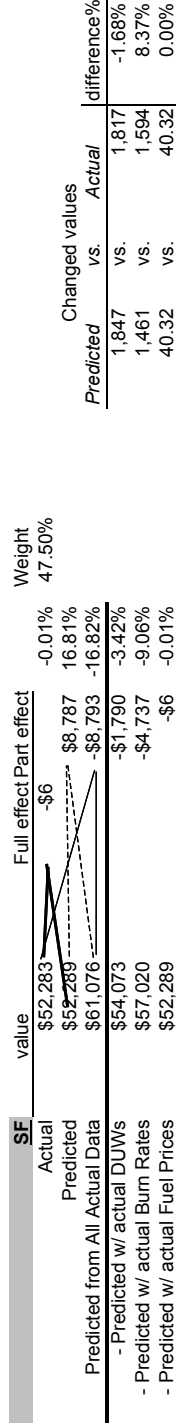

How is predicted value calculated for 2002?

SE

Deployed:

DUW

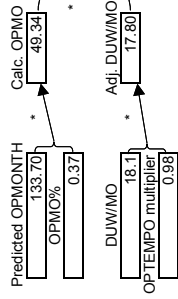

DNWU

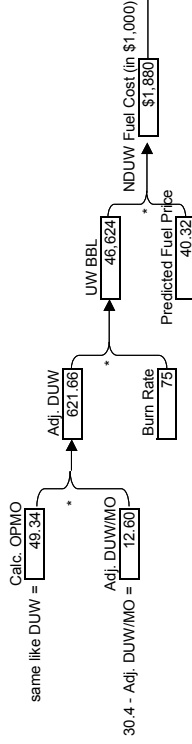

Not Deployed:

DUW

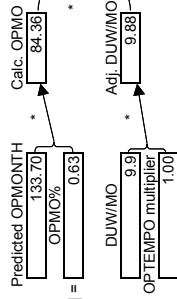

DNWU

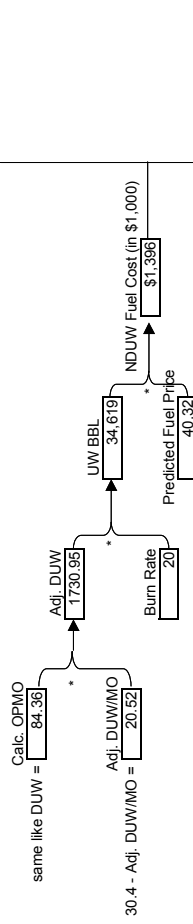

Repair:

Predicted OPMONTH Ship Year = 13.00

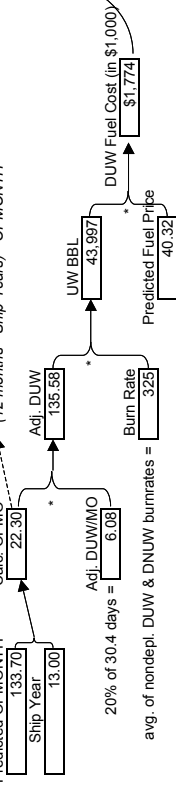

SF Cost \$52,289

	Actual SU Cost	Actual OPMONTH	SU Unit Cost	Actual Price Growths	SU Unit Cost in Year-1 dollar
Year-3	\$8,055	/ 131.5	= \$61	[Y-3]->[Y-2] 95.20% * [Y-2]->[Y-1] 100.50%	= \$58.61
Year-2	\$8,821	/ 137	= \$64	*	= \$64.71
Year-1	\$8,736	/ 140.86	= \$62		= \$62.02
				Average:	\$61.78

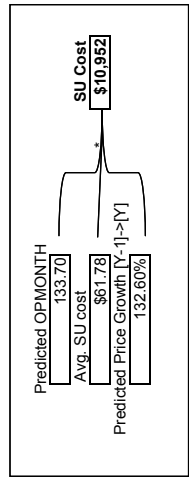

	(Actual SR Cost - Incr Cost) / Ship Yr	SR Unit Cost	Actual Price Growths	SR Unit Cost in Year-1 dollar
Year-3	\$28,602 - 2,556 / 13.00	= \$2,397	[Y-3]->[Y-2] 98.60% * [Y-2]->[Y-1] 111.30%	= \$2,630.26
Year-2	\$35,726 - 1,740 / 13.00	= \$2,882	*	= \$3,207.67
Year-1	\$35,017 - 1,372 / 13.00	= \$2,799		= \$2,799.15
			Average:	\$2,879.03

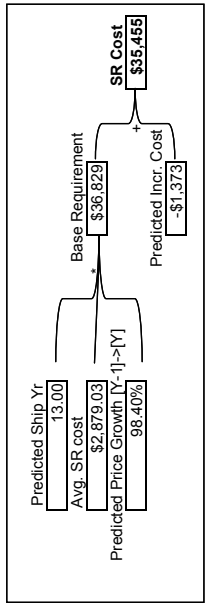

	(Actual SO Cost - Incr Cost) / Ship Yr	SO Unit Cost	Actual Price Growths	SO Unit Cost in Year-1 dollar
Year-3	\$16,388 - 0 / 13.00	= \$1,261	[Y-3]->[Y-2] 100.40% * [Y-2]->[Y-1] 103.90%	= \$1,315.02
Year-2	\$11,307 - 0 / 13.00	= \$870	*	= \$903.69
Year-1	\$13,333 - 0 / 13.00	= \$1,026		= \$1,025.62
			Average:	\$1,081.44

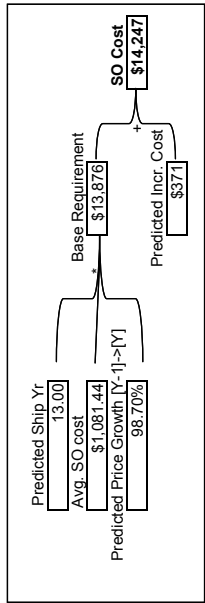

How is predicted value from actual data calculated for 2022?

SF

Deployed:

DUW

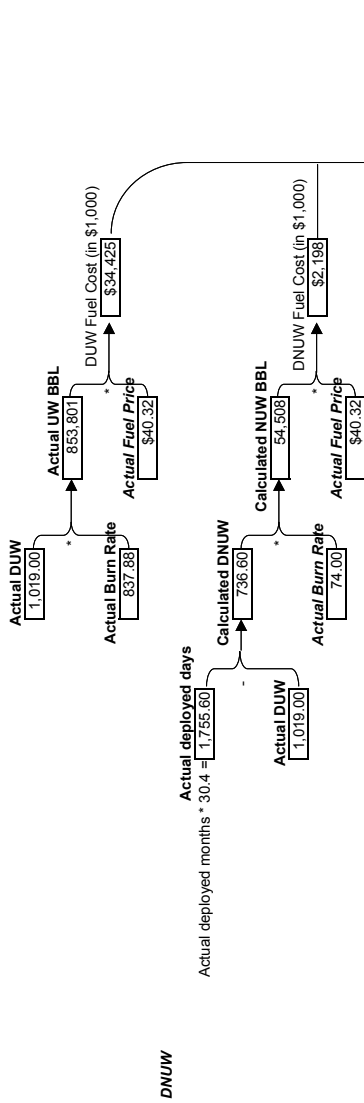

Not Deployed:

DUW

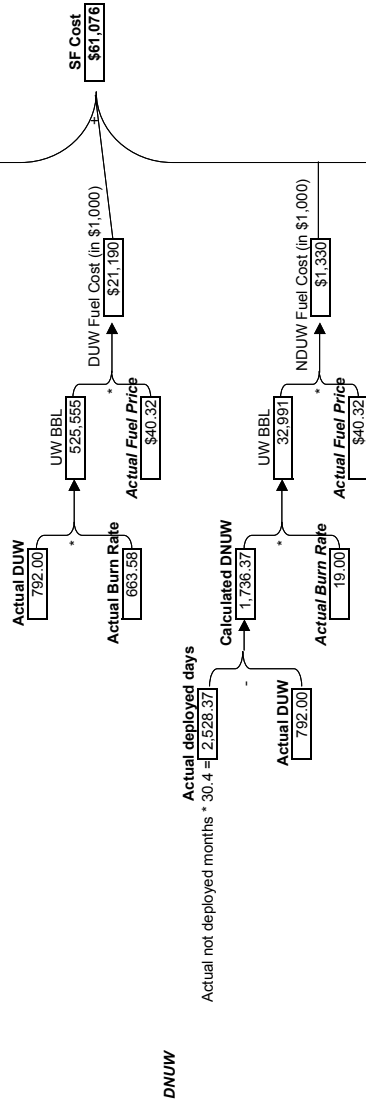

Repair:

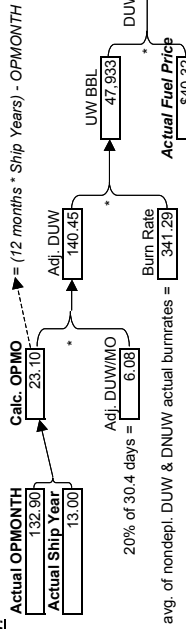

SF Cost

\$61,076

SU

	Actual SU Cost	Actual OPMONTH	SU Unit Cost	Actual Price Growths	SU Unit Cost in Year-1 dollar
Year-3	\$8,055	131.5	\$61	95.20%	\$58.61
Year-2	\$8,821	137	\$64	100.50%	\$64.71
Year-1	\$8,736	140.86	\$62	100.50%	\$62.02
					Average: \$61.78

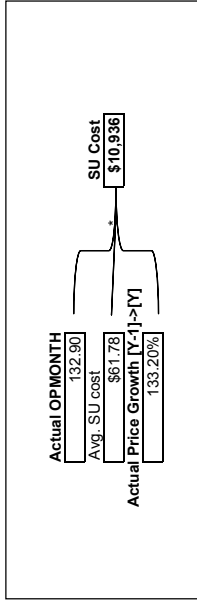

SR

	(Actual SR Cost - Incr. Cost) / Ship Yr	SR Unit Cost	Actual Price Growths	SR Unit Cost in Year-1 dollar
Year-3	\$28,602 / -2,556 / 13.00	\$2,397	98.60%	\$2,630.26
Year-2	\$35,726 / -1,740 / 13.00	\$2,882	111.30%	\$3,207.67
Year-1	\$35,017 / -1,372 / 13.00	\$2,799	111.30%	\$2,799.15
				Average: \$2,879.03

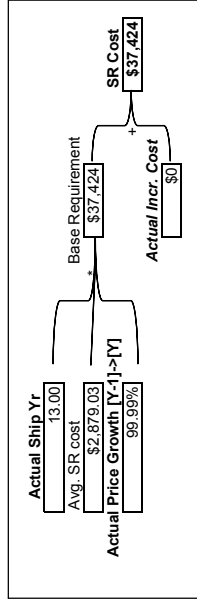

SO

	(Actual SO Cost - Incr. Cost) / Ship Yr	SO Unit Cost	Actual Price Growths	SO Unit Cost in Year-1 dollar
Year-3	\$16,388 / 0 / 13.00	\$1,261	100.40%	\$1,315.02
Year-2	\$11,307 / 0 / 13.00	\$870	103.90%	\$903.69
Year-1	\$13,333 / 0 / 13.00	\$1,026	103.90%	\$1,025.62
				Average: \$1,081.44

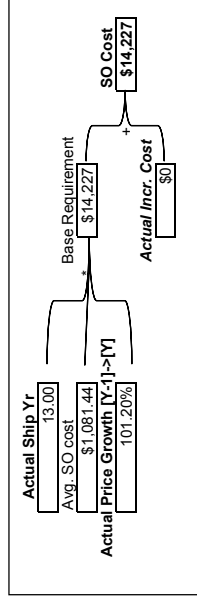

Inputs:
 Fleet PacFleet
 Ship Class CG-47CL
 Program Element 0204221N
 OMN/OMNR OMN
 Resource Sponsor (new) 76
 Resource Sponsor (old) 86

PRIMARY INPUTS

Actual Data	1994	1995	1996	1997	1998	1999	2000	2001	2002
SF	\$39,132	\$36,148	\$34,669	\$37,162	\$47,709	\$41,010	\$29,459	\$47,147	\$52,283
SU	\$8,213	\$6,936	\$9,115	\$8,902	\$9,814	\$8,055	\$8,821	\$8,736	\$12,838
SR	\$15,615	\$30,496	\$27,437	\$26,353	\$27,573	\$28,602	\$35,726	\$35,017	\$32,843
SO	\$11,555	\$15,143	\$10,831	\$9,532	\$14,222	\$16,388	\$11,307	\$13,333	\$12,106
Total Cost	\$74,515	\$88,723	\$82,052	\$81,949	\$99,318	\$94,055	\$85,313	\$104,233	\$110,070
Ship Year	12.30	13.00	13.00	13.00	13.00	13.00	13.00	13.00	13.00
OPMONTH	128.00	130.00	132.00	131.30	141.00	131.50	137.00	140.86	132.90
OPMO%	N/A	N/A	N/A	0.39	0.37	0.43	0.35	0.38	0.43
Depl. DUJW/MO	N/A	N/A	N/A	18.06	17.76	18.53	15.08	16.90	17.65
Depl. OPTEMPO multiplier	N/A	N/A	N/A	1.04	1.02	1.07	0.87	0.97	1.02
Depl. DUW Burn Rate	N/A	N/A	N/A	629	729	728	424	720	838
Depl. DNUW Burn Rate	N/A	N/A	N/A	74	74	74	74	74	74
Depl. Fuel Price	N/A	N/A	N/A	\$31.08	\$36.96	\$33.60	\$25.20	\$41.16	\$40.32
Not Depl. DUJW/MO	N/A	N/A	N/A	9.57	8.10	9.00	10.40	8.82	9.52
Not Depl. OPTEMPO multiplier	N/A	N/A	N/A	1.03	0.87	0.96	1.11	0.95	1.02
Not Depl. DUW Burn Rate	N/A	N/A	N/A	619	597	666	185	604	664
Not Depl. DNUW Burn Rate	N/A	N/A	N/A	19	19	19	19	19	19
Not Depl. Fuel Price	N/A	N/A	N/A	\$31.08	\$36.96	\$33.60	\$25.20	\$41.16	\$40.32
SU Price Growth	N/A	98.80%	98.80%	99.18%	97.30%	99.40%	95.20%	100.50%	133.20%
SR Price Growth	N/A	103.11%	98.87%	107.52%	113.95%	95.63%	98.60%	111.30%	99.99%
SR Incremental Cost	\$0	-\$3,954	-\$2,286	-\$2,957	-\$4,300	-\$2,556	-\$1,740	-\$1,372	\$0
SO Price Growth	N/A	103.11%	98.87%	105.45%	108.19%	100.74%	100.40%	103.90%	101.20%
SO Incremental Cost	\$0	-\$36	-\$89	\$0	\$0	\$0	\$0	\$0	\$0

from OP-41 List
 from OP-41 List
 from OP-41 List
 from OP-41 List
 sum row
 from OP-41 List
 from OP-41 List
 determined from calculated inputs,
 informative data, not used
 determined from calculated inputs,
 informative data, not used
 determined from calculated inputs,
 informative data, not used
 calculated from NUJERS data
 calculated from NUJERS data??
 from the model (FY-CL sheet),
 same as predicted (fixed)
 determined from calculated inputs,
 informative data, not used
 determined from calculated inputs,
 informative data, not used
 calculated from NUJERS data
 calculated from NUJERS data??
 from the model (FY-CL sheet),
 same as predicted (fixed)
 from the model (FY-CL sheet)
 from the model (FY-CL-RS sheet)
 from the model (Incremental SR
 sheet)
 from the model (FY-CL-RS sheet)
 from the model (Incremental SO
 sheet)

CALCULATED INPUTS

Actual Data	1994	1995	1996	1997	1998	1999	2000	2001	2002
Deployed Months	41.16	54.55	35.45	51.67	52.43	56.67	47.48	53.20	57.75
Not-Deployed Months	104.84	86.21	115.55	94.94	89.02	74.92	88.11	87.75	83.17
Maintenance Months	0.66	1.15	0.33	0.33	1.64	0.49	1.97	0.00	0.99
Deployed Days Underway	714.00	971.00	541.00	933.00	931.00	1,050.00	716.00	899.00	1,019.00
Deployed Days Not-underway	537.26	687.32	536.68	637.77	662.87	672.77	727.39	718.28	736.60
Not-Deployed Days Underway	933.00	838.00	1,004.00	909.00	721.00	674.00	916.00	774.00	792.00
Not-Deployed Days Not-Underway	2,254.14	1,782.78	2,508.72	1,977.18	1,985.21	1,603.57	1,762.54	1,893.60	1,736.37

~ derived from NUERS data
 ~ derived from NUERS data
 ~ derived from NUERS data
 ~ derived from NUERS data
 ~ = (Deployed Months * 30.4 days) -
 Depl. Days Underway
 ~ derived from NUERS data
 ~ = (Not-Deployed Months * 30.4
 days) - Not-Depl. Days Underway

Predicted Data	1994	1995	1996	1997	1998	1999	2000	2001	2002
Deployed Months	N/A	N/A	N/A	48.45	52.03	48.71	47.23	51.98	49.34
Not-Deployed Months	N/A	N/A	N/A	82.85	88.97	83.29	80.77	88.88	84.36
Maintenance Months	N/A	N/A	N/A	24.70	15.00	24.00	28.00	15.14	22.30
Deployed Days Underway	N/A	N/A	N/A	876.06	847.55	914.23	753.17	885.28	878.14
Deployed Days Not-underway	N/A	N/A	N/A	596.81	734.13	566.49	682.69	694.83	621.66
Not-Deployed Days Underway	N/A	N/A	N/A	872.71	1,056.98	989.51	792.81	904.58	833.74
Not-Deployed Days Not-Underway	N/A	N/A	N/A	1,645.94	1,647.74	1,542.57	1,662.54	1,797.46	1,730.95

~ = OPMONTH * OPOMO%
 ~ = OPMONTH * (1-OPMO%)
 ~ = (Ship Year * 12) - OPMONTH
 ~ = Deployed Months * Depl.
 DUW/MO * Depl. OPTEMPO
 ~ = Deployed Months * (30.4 - (Depl.
 DUW/MO * Depl. OPTEMPO))
 ~ = Not-Deployed Months * Not-
 Depl. DUW/MO * Not-Depl.
 OPTEMPO
 ~ = Not-Deployed Months * (30.4 -
 (Not-Depl. DUW/MO * Not-Depl.
 OPTEMPO))

- missing data, temporary substituted by predicted/actual/previous data
 - calculated value, used for comparison, but not directly in the model

Marked
italic

Fleet	PacFleet
Ship Class	DD-963CL
Program Element	0204223N
OMN/OMNR	OMN
Resource Sponsor (new)	76
Resource Sponsor (old)	86

Appraisal of Model Accuracy
using backcast: 1997-2002

	Year	SF	SU	SR	SO	Total
Actuals	1997	\$36,875	\$7,218	\$22,937	\$8,367	\$75,397
	1998	\$37,121	\$7,186	\$23,714	\$13,182	\$81,203
	1999	\$31,897	\$5,458	\$17,479	\$7,556	\$62,390
	2000	\$23,846	\$5,370	\$25,828	\$11,072	\$66,116
	2001	\$32,718	\$5,417	\$22,984	\$13,239	\$74,358
	2002	\$35,238	\$5,765	\$17,310	\$8,350	\$66,663
Predicted from All Actual Data	1997	\$38,290	\$6,569	\$22,508	\$11,300	\$78,667
	1998	\$37,484	\$6,235	\$22,559	\$9,447	\$75,724
	1999	\$33,266	\$5,328	\$16,986	\$8,860	\$64,440
	2000	\$13,858	\$5,230	\$19,202	\$8,527	\$46,817
	2001	\$35,897	\$5,280	\$23,241	\$9,898	\$74,315
	2002	\$39,416	\$6,420	\$22,602	\$9,688	\$78,126
Actual - Pred. Fr Actual	1997	-\$1,415	\$649	\$429	-\$2,933	-\$3,270
	1998	-\$363	\$951	\$1,155	\$3,735	\$5,479
	1999	-\$1,369	\$130	\$493	-\$1,304	-\$2,050
	2000	\$9,988	\$140	\$6,626	\$2,545	\$19,299
	2001	-\$3,179	\$137	-\$257	\$3,341	\$43
	2002	-\$4,178	-\$655	-\$5,292	-\$1,338	-\$11,463
Actual - Pred. Fr Actual Actual	1997	-3.84%	8.99%	1.87%	-35.06%	-4.34%
	1998	-0.98%	13.24%	4.87%	28.34%	6.75%
	1999	-4.29%	2.39%	2.82%	-17.26%	-3.29%
	2000	41.89%	2.61%	25.65%	22.98%	29.19%
	2001	-9.72%	2.54%	-1.12%	25.24%	0.06%
	2002	-11.86%	-11.37%	-30.57%	-16.03%	-17.20%
MAPE* =		12.09%	6.86%	11.15%	24.15%	10.14%

* Mean Absolute Percentage Error (avg of the abs value of errors %)

** SF's MAPE without year 2000 = **6.14%**

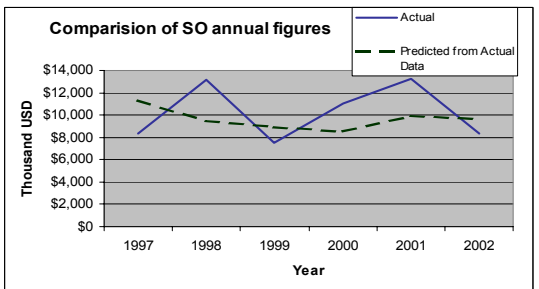
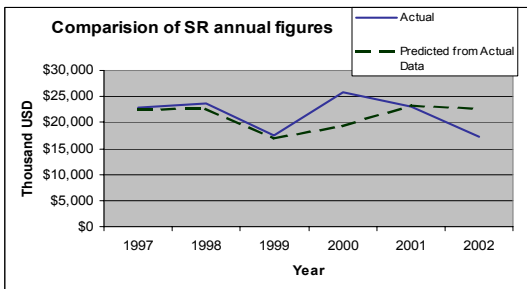
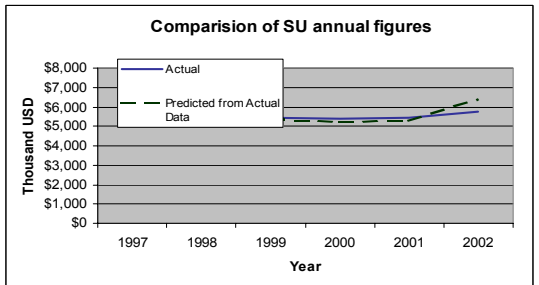
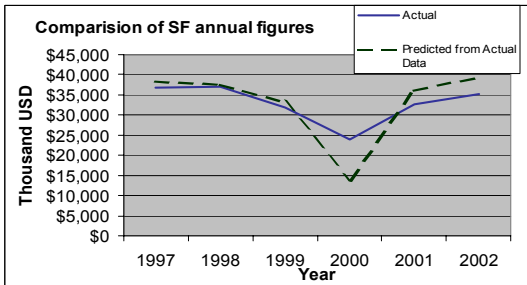
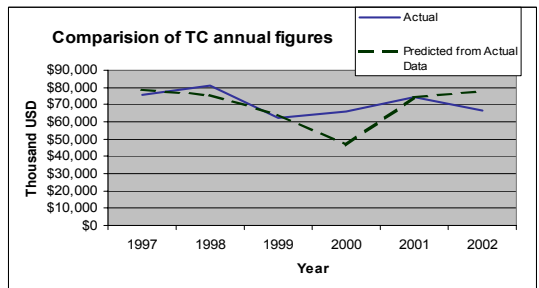
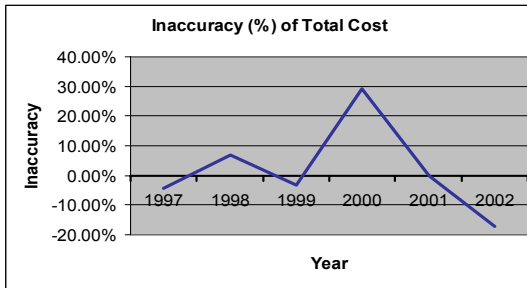
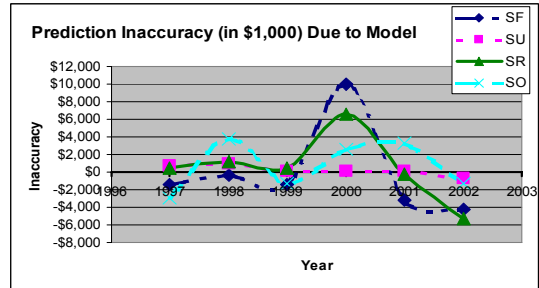
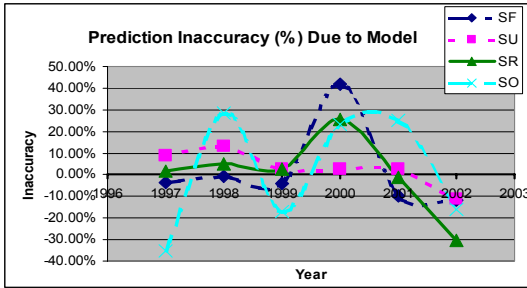

Appraisal of prediction for 2002

Inputs:	PacFleet
Fleet	DD-963CL
Ship Class	0204223N
Program Element	OMN
OMN/OMNR	76
Resource Sponsor (new)	86
Resource Sponsor (old)	

	SF	SU	SR	SO	Total
Actual	\$35,238	\$5,765	\$17,310	\$8,350	\$66,663
Predicted	\$34,444	\$6,249	\$21,068	\$9,611	\$71,373
Predicted from All Actual Data	\$39,416	\$6,420	\$22,602	\$9,688	\$78,126
Actual - Predicted	\$794	-\$484	-\$3,758	-\$1,261	-\$4,710
- Pred. fr Actual - Predicted	\$4,971	\$171	\$1,534	\$77	\$6,753
- Actual - Pred. Fr Actual	-\$4,178	-\$655	-\$5,292	-\$1,338	-\$11,463

-7.06% -> model total inaccuracy
 10.13% -> source data inaccuracy
 -17.20% -> model inaccuracy

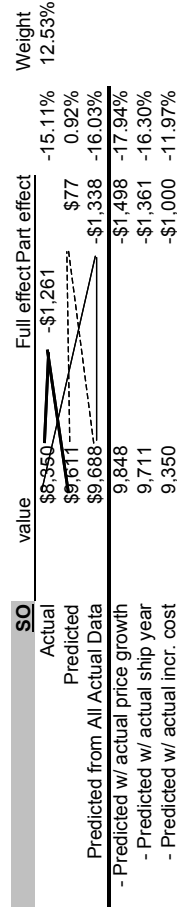
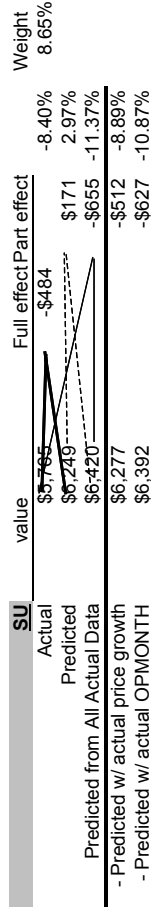
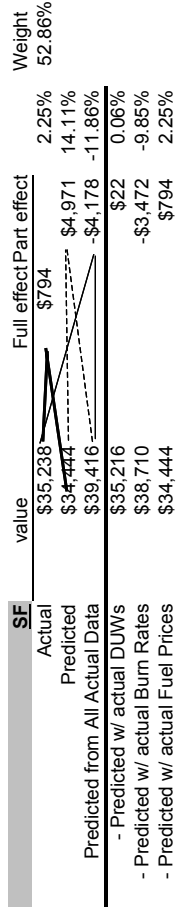

How is predicted value calculated for 2022?

SF

Deployed:

DUW

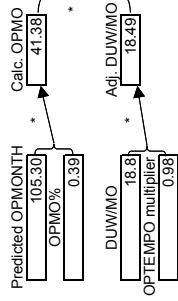

DNUIW

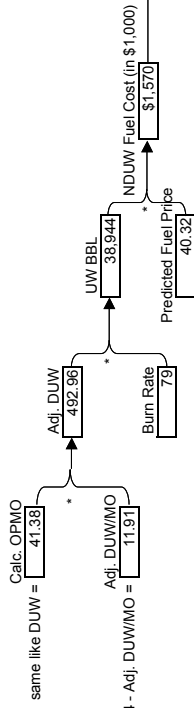

Not Deployed:

DUW

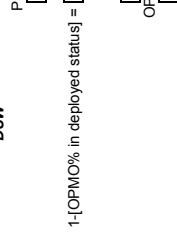

DNUIW

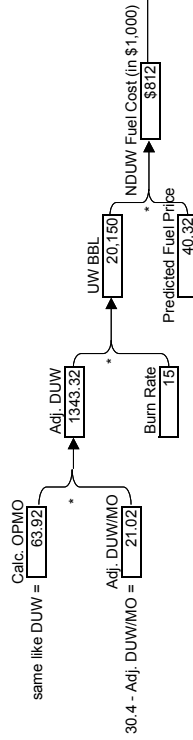

Repair:

Predicted OPMONTH = 105.30
 Ship Year = 9.40
 Calc. OPMO = 7.50
 Adj. DUW/MO = 6.08
 Adj. DUW = 45.60
 Burn Rate = 274
 UW BBL = 12,472
 Predicted Fuel Pribe = 40.32
 DUW Fuel Cost (in \$1,000) = \$503

SF Cost \$34,444

SU

	Actual SU Cost	Actual OPMONTH	SU Unit Cost	Actual Price Growths	SU Unit Cost in Year-1 dollar
Year-3	\$5,458	/ 121.2	= \$45	[Y-3]->[Y-2] 95.20% * [Y-2]->[Y-1] 100.50%	= \$43.09
Year-2	\$5,370	/ 119	= \$45	*	= \$45.35
Year-1	\$5,417	/ 118.2	= \$46	*	= \$45.83
					Average: \$44.76

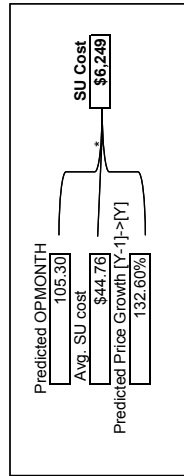

SR

	(Actual SR Cost - Incr.Cost) / Ship Yr	=	SR Unit Cost	Actual Price Growths	SR Unit Cost in Year-1 dollar
Year-3	\$17,479 - 3,408 / 11.00	=	\$1,899	[Y-3]->[Y-2] 98.60% * [Y-2]->[Y-1] 111.30%	= \$2,083.80
Year-2	\$25,828 - 1,395 / 11.00	=	\$2,475	*	= \$2,754.48
Year-1	\$22,984 - 1,164 / 10.50	=	\$2,300	*	= \$2,299.81
					Average: \$2,379.36

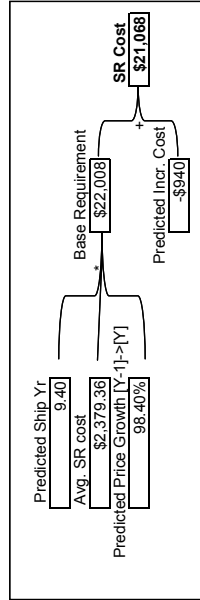

SO

	(Actual SO Cost - Incr.Cost) / Ship Yr	=	SO Unit Cost	Actual Price Growths	SO Unit Cost in Year-1 dollar
Year-3	\$7,556 - 0 / 11.00	=	\$687	[Y-3]->[Y-2] 100.40% * [Y-2]->[Y-1] 103.90%	= \$716.55
Year-2	\$11,072 - 0 / 11.00	=	\$1,007	*	= \$1,045.80
Year-1	\$13,239 - 0 / 10.50	=	\$1,261	*	= \$1,260.86
					Average: \$1,007.74

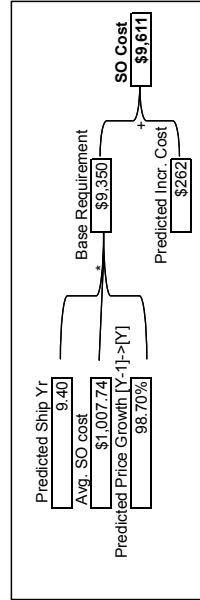

How is predicted value from actual data calculated for 20022

SF

Deployed:

DUW

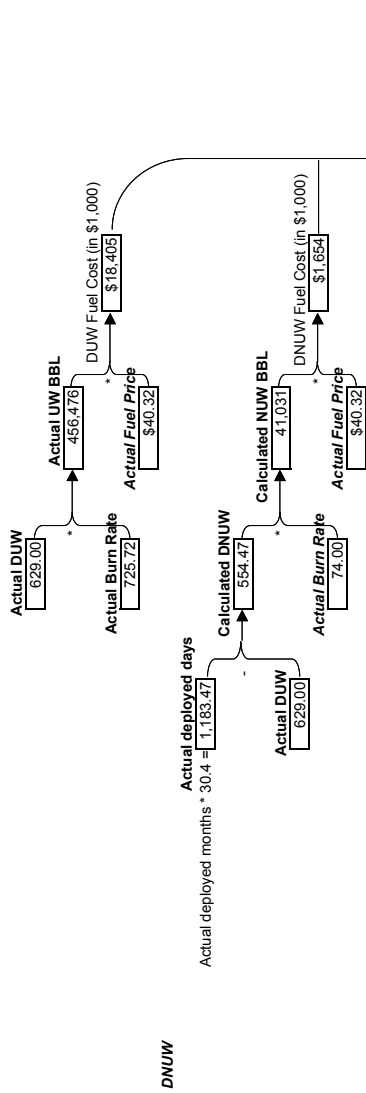

Not Deployed:

DUW

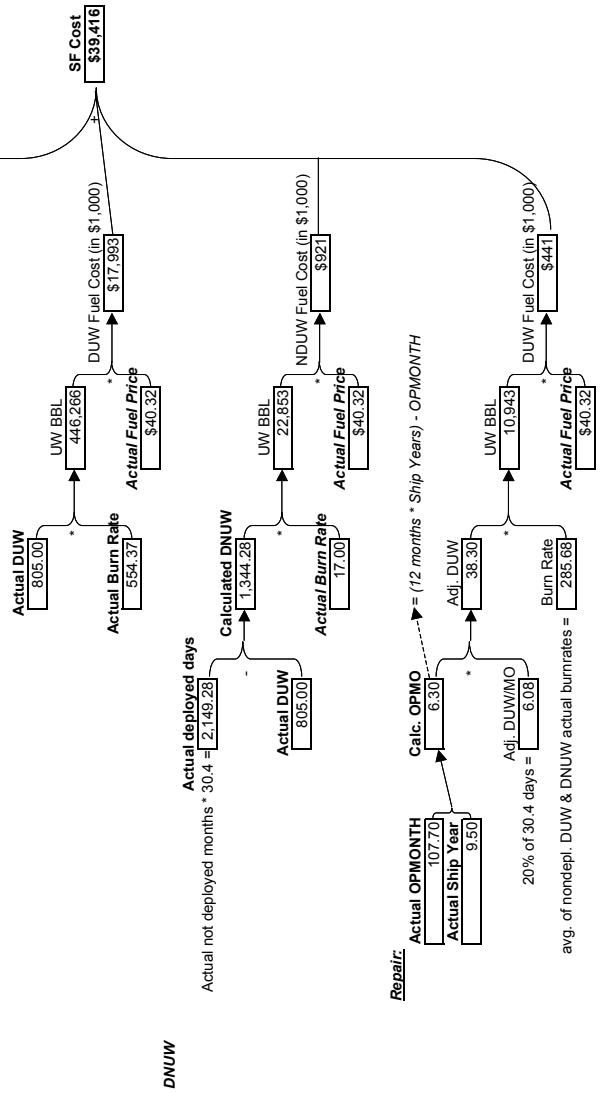

SU

	Actual SU Cost	Actual OPMONTH	SU Unit Cost	Actual Price Growths [Y-3]->[Y-2]	[Y-2]->[Y-1]	SU Unit Cost in Year-1 dollar
Year-3	\$5,458	/ 121.2	= \$45	95.20%	100.50%	= \$43.09
Year-2	\$5,370	/ 119	= \$45	*	*	= \$45.35
Year-1	\$5,417	/ 118.2	= \$46			= \$45.83
						Average: \$44.76

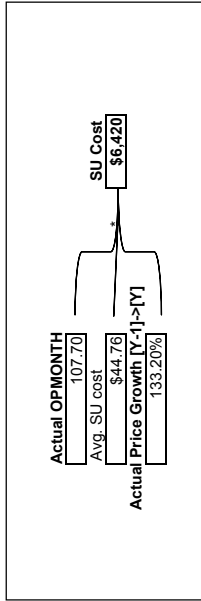

SR

	(Actual SR Cost - Incr.Cost) / Ship Yr	SR Unit Cost	Actual Price Growths [Y-3]->[Y-2]	[Y-2]->[Y-1]	SR Unit Cost in Year-1 dollar
Year-3	\$17,479 / -3,408	= 11.00	98.60%	111.30%	= \$2,083.80
Year-2	\$25,828 / -1,395	= 11.00	*	*	= \$2,754.48
Year-1	\$22,984 / -1,164	= 10.50			= \$2,299.81
					Average: \$2,379.36

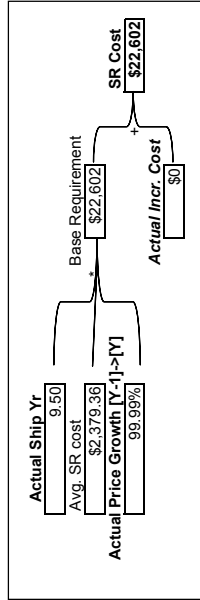

SO

	(Actual SO Cost - Incr.Cost) / Ship Yr	SO Unit Cost	Actual Price Growths [Y-3]->[Y-2]	[Y-2]->[Y-1]	SO Unit Cost in Year-1 dollar
Year-3	\$7,556 / 0	= 11.00	100.40%	103.90%	= \$716.55
Year-2	\$11,072 / 0	= 11.00	*	*	= \$1,045.80
Year-1	\$13,239 / 0	= 10.50			= \$1,260.86
					Average: \$1,007.74

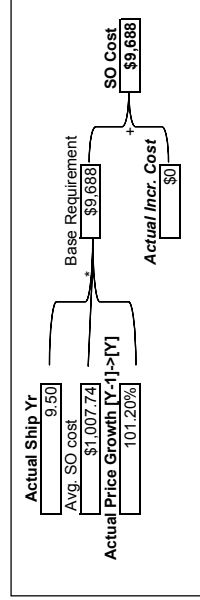

Inputs:
 Fleet PacFleet
 Ship Class DD-963CL
 Program Element 0204223N
 OMN/OMNR OMN
 Resource Sponsor (new) 76
 Resource Sponsor (old) 86

PRIMARY INPUTS

Actual Data	1994	1995	1996	1997	1998	1999	2000	2001	2002
SF	\$35,992	\$28,548	\$36,978	\$36,875	\$37,121	\$31,897	\$23,846	\$32,718	\$35,238
SU	\$6,883	\$5,067	\$6,048	\$7,218	\$7,186	\$5,458	\$5,370	\$5,417	\$5,765
SR	\$21,840	\$22,508	\$20,841	\$22,937	\$23,714	\$17,479	\$25,828	\$22,984	\$17,310
SO	\$11,202	\$10,560	\$10,232	\$8,367	\$13,182	\$7,556	\$11,072	\$13,239	\$8,350
Total Cost	\$75,917	\$66,683	\$74,099	\$75,397	\$81,203	\$62,390	\$66,116	\$74,358	\$66,663
Ship Year	15.00	15.00	15.00	15.00	13.00	11.00	11.00	10.50	9.50
OPMONTH	137.00	121.00	151.00	152.30	150.00	121.20	119.00	118.20	107.70
OPMO%	N/A	N/A	N/A	0.44	0.33	0.41	0.38	0.35	0.36
Depl. DUW/MO	N/A	N/A	N/A	16.78	17.62	19.34	17.61	17.46	16.16
Depl. OPTEMPO multiplier	N/A	N/A	N/A	0.97	1.02	1.12	1.02	1.01	0.93
Depl. DUW Burn Rate	N/A	N/A	N/A	572	589	592	364	601	726
Depl. DNUW Burn Rate	N/A	N/A	N/A	74	74	74	74	74	74
Depl. Fuel Price	N/A	N/A	N/A	\$31.08	\$36.96	\$33.60	\$25.20	\$41.16	\$40.32
Not Depl. DUW/MO	N/A	N/A	N/A	8.19	7.55	9.00	8.76	9.34	11.39
Not Depl. OPTEMPO multiplier	N/A	N/A	N/A	0.88	0.81	0.96	0.94	1.00	1.22
Not Depl. DUW Burn Rate	N/A	N/A	N/A	536	525	545	285	511	554
Not Depl. DNUW Burn Rate	N/A	N/A	N/A	17	17	17	17	17	17
Not Depl. Fuel Price	N/A	N/A	N/A	\$31.08	\$36.96	\$33.60	\$25.20	\$41.16	\$40.32
SU Price Growth	N/A	98.80%	98.80%	99.18%	97.30%	99.40%	95.20%	100.50%	133.20%
SR Price Growth	N/A	103.11%	98.87%	107.52%	113.95%	95.63%	98.60%	111.30%	99.99%
SR Incremental Cost	\$0	-\$2,919	-\$1,736	-\$2,573	-\$2,728	-\$3,408	-\$1,395	-\$1,164	\$0
SO Price Growth	N/A	103.11%	98.87%	105.45%	108.19%	100.74%	100.40%	103.90%	101.20%
SO Incremental Cost	\$0	-\$18	-\$38	\$0	\$0	\$0	\$0	\$0	\$0

from OP-41 List
 from OP-41 List
 from OP-41 List
 from OP-41 List
 sum row
 from OP-41 List
 from OP-41 List
 determined from calculated inputs,
 informative data, not used
 determined from calculated inputs,
 informative data, not used
 determined from calculated inputs,
 informative data, not used
 calculated from NUJERS data
 calculated from NUJERS data??
 from the model (FY-CL sheet),
 same as predicted (fixed)
 determined from calculated inputs,
 informative data, not used
 determined from calculated inputs,
 informative data, not used
 calculated from NUJERS data
 calculated from NUJERS data??
 from the model (FY-CL sheet),
 same as predicted (fixed)
 from the model (FY-CL sheet)
 from the model (FY-CL-RS sheet)
 from the model (Incremental SR
 sheet)
 from the model (FY-CL-RS sheet)
 from the model (Incremental SO
 sheet)

Predicted Data	1994	1995	1996	1997	1998	1999	2000	2001	2002
SF	N/A	N/A	N/A	\$39,386	\$45,272	\$35,858	\$14,110	\$38,241	\$34,444
SU	N/A	N/A	N/A	\$6,569	\$6,587	\$5,231	\$5,180	\$5,337	\$6,249
SR	N/A	N/A	N/A	\$22,508	\$22,559	\$16,676	\$17,027	\$19,194	\$21,068
SO	N/A	N/A	N/A	\$11,300	\$9,447	\$8,808	\$8,379	\$9,704	\$9,611
Total Cost	N/A	N/A	N/A	\$79,764	\$83,865	\$66,574	\$44,896	\$72,477	\$71,373
Ship Year	N/A	N/A	N/A	15.00	13.00	11.00	11.00	10.50	9.40
OPMONTH	N/A	N/A	N/A	152.30	150.00	119.00	119.00	118.20	105.30
OPMO%	N/A	N/A	N/A	0.39	0.39	0.39	0.39	0.39	0.39
Depl. DUW/MO	N/A	N/A	N/A	18.8	18.8	18.8	18.8	18.8	18.8
Depl. OPTEMPO multiplier	N/A	N/A	N/A	1.00	0.90	1.04	0.88	0.94	0.98
Depl. DUW Burn Rate	N/A	N/A	N/A	572	589	592	364	601	606
Depl. DNUW Burn Rate	N/A	N/A	N/A	79	79	79	79	79	79
Depl. Fuel Price	N/A	N/A	N/A	\$31.08	\$36.96	\$33.60	\$25.20	\$41.16	\$40.32
Not Depl. DUW/MO	N/A	N/A	N/A	9.4	9.4	9.4	9.4	9.4	9.4
Not Depl. OPTEMPO multiplier	N/A	N/A	N/A	1.06	1.20	1.20	0.99	1.03	1.00
Not Depl. DUW Burn Rate	N/A	N/A	N/A	536	525	545	285	511	532
Not Depl. DNUW Burn Rate	N/A	N/A	N/A	15	15	15	15	15	15
Not Depl. Fuel Price	N/A	N/A	N/A	\$31.08	\$36.96	\$33.60	\$25.20	\$41.16	\$40.32
SU Price Growth	N/A	N/A	N/A	99.18%	102.80%	99.40%	94.30%	101.60%	132.60%
SR Price Growth	N/A	N/A	N/A	107.52%	113.95%	95.63%	98.00%	101.60%	98.40%
SR Incremental Cost	N/A	N/A	N/A	-\$2,573	-\$2,728	-\$3,717	-\$3,445	-\$3,084	-\$940
SO Price Growth	N/A	N/A	N/A	105.45%	108.19%	100.74%	98.65%	101.74%	98.70%
SO Incremental Cost	N/A	N/A	N/A	\$0	\$0	-\$52	\$0	\$12	\$262

prediction based on the model's methodology
prediction based on the model's methodology
prediction based on the model's methodology
prediction based on the model's methodology
sum row
from different OP-41 Lists
from different OP-41 Lists
from different models (Burn Rate sheet)
from different models (Burn Rate sheet)
from different models (FY-CL sheet)
from different models (Burn Rate sheet)
from different models (Burn Rate sheet)
from different models (FY-CL sheet)
from different models (Burn Rate sheet)
from different models (Burn Rate sheet)
from different models (FY-CL sheet)
from different models (Burn Rate sheet)
from different models (Burn Rate sheet)
from different models (FY-CL sheet)
from different models (FY-CL-RS sheet)
from different models (Incremental SR sheet)
from different models (FY-CL-RS sheet)
from different models (Incremental SO sheet)

CALCULATED INPUTS

Actual Data	1994	1995	1996	1997	1998	1999	2000	2001	2002
Deployed Months	59.57	57.73	53.09	67.34	49.37	49.17	45.70	41.86	38.93
Not-Deployed Months	89.10	73.25	106.91	99.02	102.43	69.88	70.28	74.20	70.70
Maintenance Months	5.92	2.47	0.82	0.33	0.66	0.33	1.15	0.49	0.00
Deployed Days Underway	891.00	941.00	840.00	1,130.00	870.00	951.00	805.00	731.00	629.00
Deployed Days Not-underway	919.93	813.99	773.94	917.14	630.85	543.77	584.28	541.54	554.47
Not-Deployed Days Underway	859.00	647.00	920.00	811.00	773.00	629.00	616.00	693.00	805.00
Not-Deployed Days Not-Underway	1,849.64	1,579.80	2,330.06	2,199.21	2,340.87	1,495.35	1,520.51	1,562.68	1,344.28

~ derived from NUERS data
 ~ derived from NUERS data
 ~ derived from NUERS data
 ~ derived from NUERS data
 ~ = (Deployed Months * 30.4 days) -
 Depl. Days Underway
 ~ derived from NUERS data
 ~ = (Not-Deployed Months * 30.4
 days) - Not-Depl. Days Underway

Predicted Data	1994	1995	1996	1997	1998	1999	2000	2001	2002
Deployed Months	N/A	N/A	N/A	59.85	58.95	46.77	46.77	46.45	41.38
Not-Deployed Months	N/A	N/A	N/A	92.45	91.05	72.23	72.23	71.75	63.92
Maintenance Months	N/A	N/A	N/A	27.70	6.00	13.00	13.00	7.80	7.50
Deployed Days Underway	N/A	N/A	N/A	1,124.13	997.43	911.75	774.59	821.78	765.08
Deployed Days Not-underway	N/A	N/A	N/A	695.43	794.65	509.97	647.12	590.38	492.96
Not-Deployed Days Underway	N/A	N/A	N/A	924.61	1,027.04	814.79	673.22	693.31	599.76
Not-Deployed Days Not-Underway	N/A	N/A	N/A	1,885.75	1,740.88	1,381.09	1,522.66	1,487.81	1,343.32

~ = OPMONTH * OPMO%
 ~ = OPMONTH * (1-OPMO%)
 ~ = (Ship Year * 12) - OPMONTH
 ~ = Deployed Months * Depl.
 DUW/MO * Depl. OPTEMPO
 ~ = Deployed Months * (30.4 - (Depl.
 DUW/MO * Depl. OPTEMPO))
 ~ = Not-Deployed Months * Not-
 Depl. DUW/MO * Not-Depl.
 OPTEMPO
 ~ = Not-Deployed Months * (30.4 -
 (Not-Depl. DUW/MO * Not-Depl.
 OPTEMPO))

- missing data, temporary substituted by predicted/actual/previous data
 - calculated value, used for comparison, but not directly in the model

Marked
italic

Fleet	PacFleet
Ship Class	FFG-7CL
Program Element	0204224N
OMN/OMNR	OMN
Resource Sponsor (new)	76
Resource Sponsor (old)	86

Appraisal of Model Accuracy
using backcast: 1997-2002

	Year	SF	SU	SR	SO	Total
Actuals	1997	\$14,449	\$4,838	\$15,297	\$7,323	\$41,907
	1998	\$16,869	\$4,645	\$16,104	\$9,433	\$47,051
	1999	\$18,386	\$4,467	\$14,301	\$6,492	\$43,646
	2000	\$12,138	\$4,000	\$14,512	\$7,645	\$38,295
	2001	\$17,555	\$3,660	\$15,295	\$11,005	\$47,515
	2002	\$18,083	\$5,181	\$13,580	\$8,465	\$45,309
Predicted from All Actual Data	1997	\$19,412	\$4,298	\$13,836	\$8,080	\$45,626
	1998	\$21,934	\$4,281	\$14,791	\$8,860	\$49,866
	1999	\$18,636	\$3,799	\$13,185	\$8,160	\$43,780
	2000	\$5,860	\$3,847	\$14,011	\$7,145	\$30,863
	2001	\$20,945	\$3,876	\$16,181	\$7,723	\$48,724
	2002	\$22,784	\$5,222	\$16,010	\$7,888	\$51,903
Actual - Pred. Fr Actual	1997	-\$4,963	\$540	\$1,461	-\$757	-\$3,719
	1998	-\$5,065	\$364	\$1,313	\$573	-\$2,815
	1999	-\$250	\$668	\$1,116	-\$1,668	-\$134
	2000	\$6,278	\$153	\$500	\$500	\$7,432
	2001	-\$3,390	-\$216	-\$886	\$3,282	-\$1,209
	2002	-\$4,701	-\$41	-\$2,430	\$577	-\$6,594
Actual - Pred. Fr Actual Actual	1997	-34.35%	11.15%	9.55%	-10.34%	-8.87%
	1998	-30.03%	7.84%	8.15%	6.07%	-5.98%
	1999	-1.36%	14.95%	7.80%	-25.70%	-0.31%
	2000	51.72%	3.83%	3.45%	6.54%	19.41%
	2001	-19.31%	-5.89%	-5.79%	29.83%	-2.54%
	2002	-26.00%	-0.79%	-17.89%	6.82%	-14.55%
MAPE* =		27.13%	7.41%	8.77%	14.22%	8.61%

* Mean Absolute Percentage Error (avg of the abs value of errors %)

** SF's MAPE without year 2000 = **22.21%**

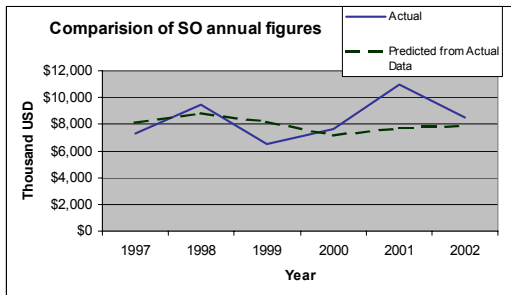
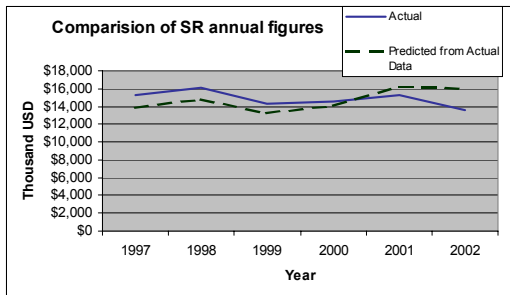
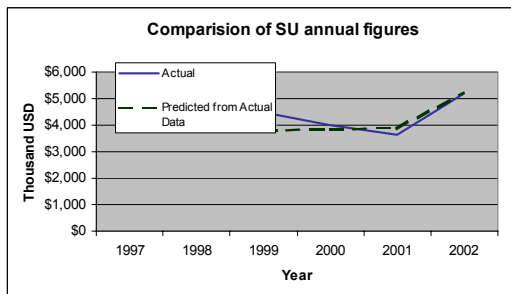
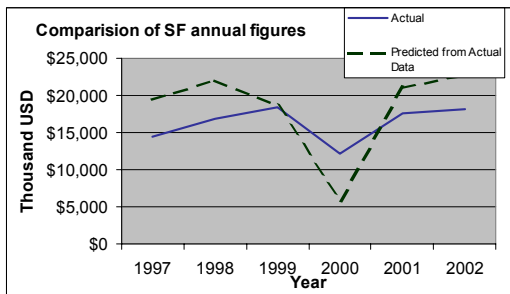
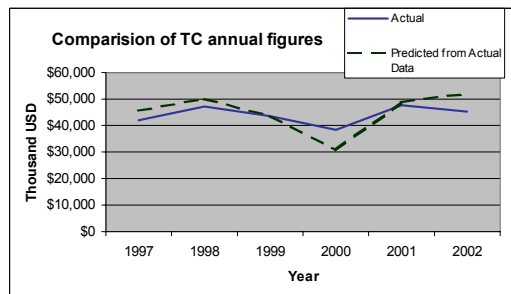
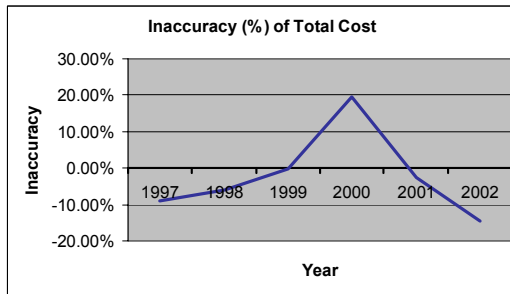
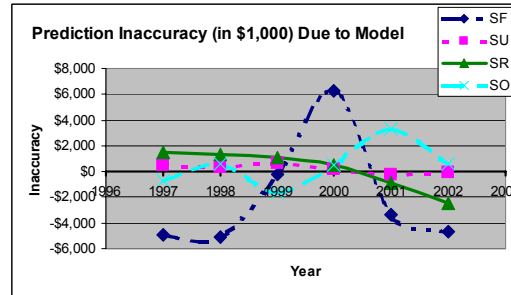
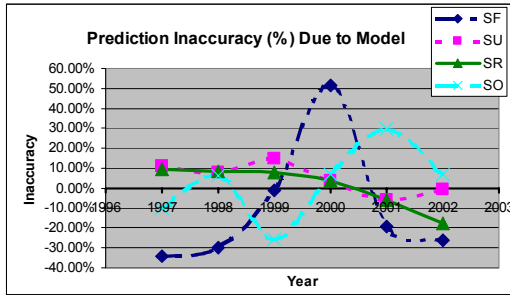

Appraisal of prediction for 2002

Inputs:	PacFleet
Fleet	FFG-7CL
Ship Class	0204224N
Program Element	OMN
OMN/OMNR	76
Resource Sponsor (new)	86
Resource Sponsor (old)	

	SF	SU	SR	SO	Total
Actual	\$18,083	\$5,181	\$13,580	\$8,465	\$45,309
Predicted	\$15,336	\$5,345	\$16,300	\$8,633	\$45,614
Predicted from All Actual Data	\$22,784	\$5,222	\$16,010	\$7,888	\$51,903
Actual - Predicted	\$2,747	-\$164	-\$2,720	-\$168	-\$305
- Pred. fr Actual - Predicted	\$7,448	-\$124	-\$290	-\$746	\$6,289
- Actual - Pred. Fr Actual	-\$4,701	-\$41	-\$2,430	\$577	-\$6,594

-0.67% -> model total inaccuracy
 13.88% -> source data inaccuracy
 -14.55% -> model inaccuracy

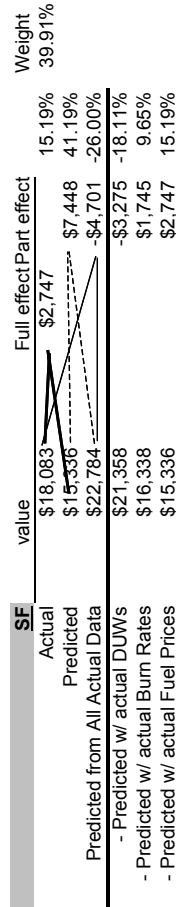

Changed values

Predicted	vs.	Actual	difference%
1,441	vs.	1,980	27.22%
551	vs.	596	7.60%
40.32	vs.	40.32	0.00%

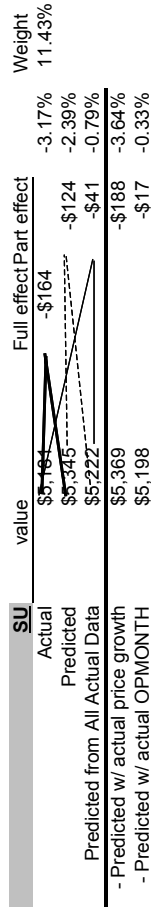

Changed values

Predicted	vs.	Actual	difference%
132.60%	vs.	133.20%	0.45%
119.90	vs.	116.60	-2.83%



Changed values

Predicted	vs.	Actual	difference%
98.40%	vs.	99.99%	1.59%
11.00	vs.	10.00	-10.00%
-1,031	vs.	0	#DIV/0!

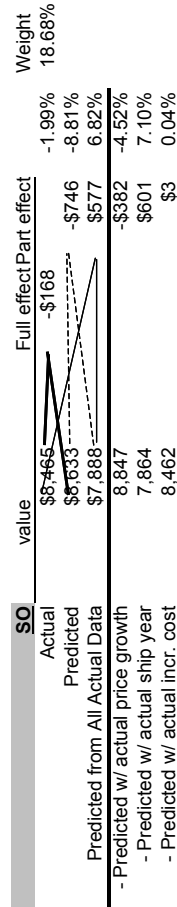

Changed values

Predicted	vs.	Actual	difference%
98.70%	vs.	101.20%	2.47%
11.00	vs.	10.00	-10.00%
171	vs.	0	#DIV/0!

How is predicted value calculated for 2022?

SF

Deployed:

DUW

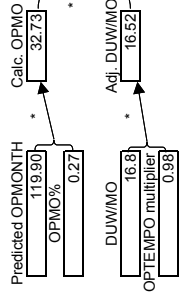

DNUW

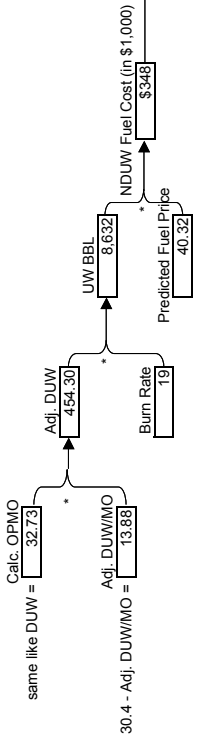

Not Deployed:

DUW

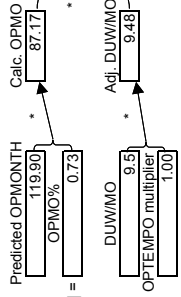

DNUW

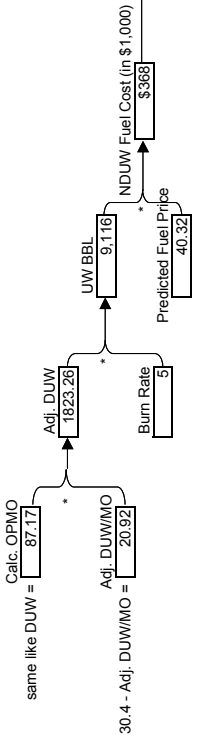

Repair:

DUW

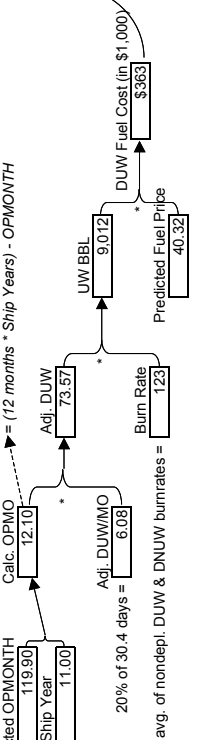
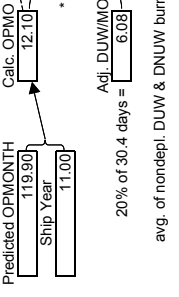

SF Cost \$15,336

SU

	Actual SU Cost	Actual OPMONTH	SU Unit Cost	Actual Price Growths	SU Unit Cost in Year-1 dollar
Year-3	\$4,467	/ 123	= \$36	[Y-3]->[Y-2] 95.20% * [Y-2]->[Y-1] 100.50%	= \$34.75
Year-2	\$4,000	/ 117	= \$34	*	= \$34.36
Year-1	\$3,660	/ 115.25	= \$32		= \$31.76
				Average:	\$33.62

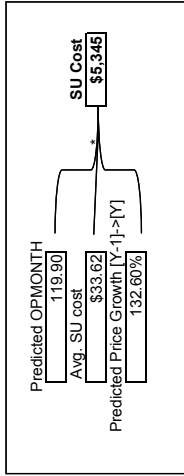

SR

	(Actual SR Cost - Incr.Cost) / Ship Yr	=	SR Unit Cost	Actual Price Growths	SR Unit Cost in Year-1 dollar
Year-3	\$14,301 - 2,099	=	11.00	[Y-3]->[Y-2] 98.60% * [Y-2]->[Y-1] 111.30%	= \$1,636.15
Year-2	\$14,512 - 1,669	=	11.00	*	= \$1,637.20
Year-1	\$15,295 - 1,536	=	11.00		= \$1,530.09
				Average:	\$1,601.15

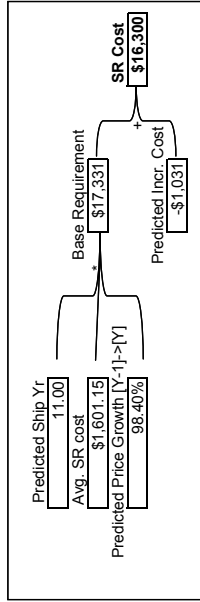

SO

	(Actual SO Cost - Incr.Cost) / Ship Yr	=	SO Unit Cost	Actual Price Growths	SO Unit Cost in Year-1 dollar
Year-3	\$6,492 - 0	=	11.00	[Y-3]->[Y-2] 100.40% * [Y-2]->[Y-1] 103.90%	= \$615.65
Year-2	\$7,645 - 0	=	11.00	*	= \$722.11
Year-1	\$11,005 - 0	=	11.00		= \$1,000.45
				Average:	\$779.40

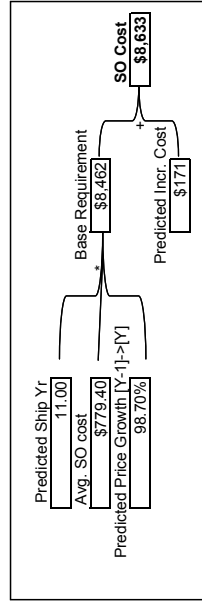

How is predicted value from actual data calculated for 20022

SF

Deployed:

DUW

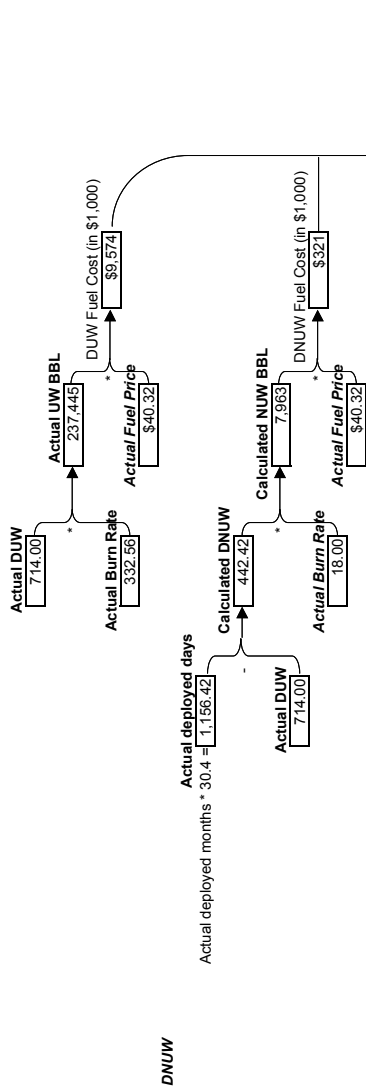

Not Deployed:

DUW

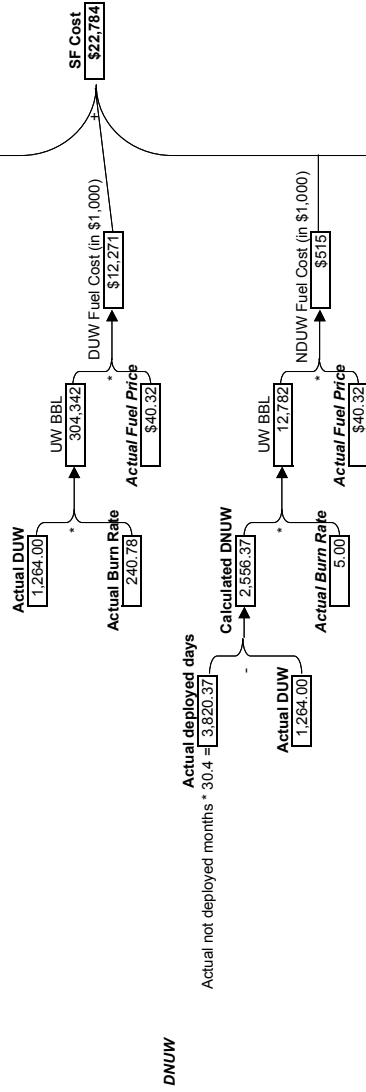

Repair:

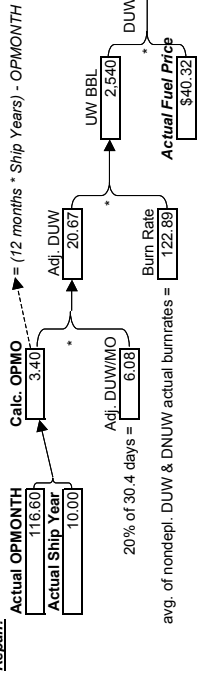

SU

	Actual SU Cost	Actual OPMONTH	SU Unit Cost	Actual Price Growths [Y-3]->[Y-2]	Actual Price Growths [Y-2]->[Y-1]	SU Unit Cost in Year-1 dollar
Year-3	\$4,467	/ 123	= \$36	* 95.20%	* 100.50%	= \$34.75
Year-2	\$4,000	/ 117	= \$34	*	* 100.50%	= \$34.36
Year-1	\$3,660	/ 115.25	= \$32			= \$31.76
					Average:	\$33.62

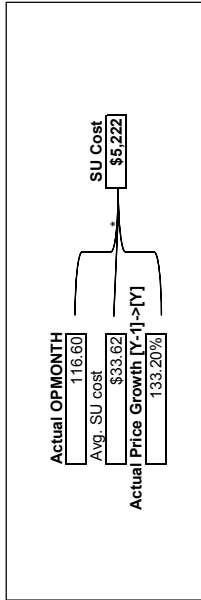

SR

	(Actual SR Cost - Incr.Cost) / Ship Yr	=	SR Unit Cost	Actual Price Growths [Y-3]->[Y-2]	Actual Price Growths [Y-2]->[Y-1]	SR Unit Cost in Year-1 dollar
Year-3	\$14,301 - 2,099	=	11.00	* 98.60%	* 111.30%	= \$1,636.15
Year-2	\$14,512 - 1,669	=	11.00	*	* 111.30%	= \$1,637.20
Year-1	\$15,295 - 1,536	=	11.00			= \$1,530.09
					Average:	\$1,601.15

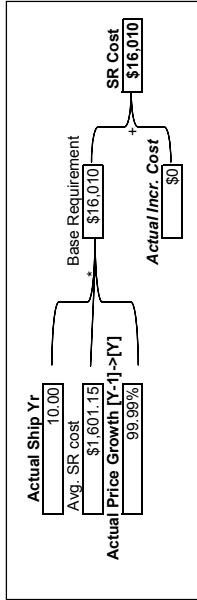

SO

	(Actual SO Cost - Incr.Cost) / Ship Yr	=	SO Unit Cost	Actual Price Growths [Y-3]->[Y-2]	Actual Price Growths [Y-2]->[Y-1]	SO Unit Cost in Year-1 dollar
Year-3	\$6,492 - 0	=	11.00	* 100.40%	* 103.90%	= \$615.65
Year-2	\$7,645 - 0	=	11.00	*	* 103.90%	= \$722.11
Year-1	\$11,005 - 0	=	11.00			= \$1,000.45
					Average:	\$779.40

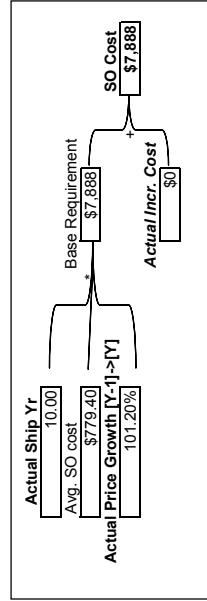

Inputs:
 Fleet PacFleet
 Ship Class FFG-7CL
 Program Element 0204224N
 OMN OMN
 Resource Sponsor (new) 76
 Resource Sponsor (old) 86

PRIMARY INPUTS

Actual Data	1994	1995	1996	1997	1998	1999	2000	2001	2002
SF	\$18,519	\$15,345	\$15,284	\$14,449	\$16,869	\$18,386	\$12,138	\$17,555	\$18,083
SU	\$4,770	\$4,613	\$3,782	\$4,838	\$4,645	\$4,467	\$4,000	\$3,660	\$5,181
SR	\$14,894	\$12,123	\$13,541	\$15,297	\$16,104	\$14,301	\$14,512	\$15,295	\$13,580
SO	\$6,329	\$6,715	\$9,827	\$7,323	\$9,433	\$6,492	\$7,645	\$11,005	\$8,465
Total Cost	\$44,512	\$38,796	\$42,434	\$41,907	\$47,051	\$43,646	\$38,295	\$47,515	\$45,309
Ship Year	13.00	13.00	13.00	13.00	12.90	11.00	11.00	11.00	10.00
OPMONTH	135.00	135.00	143.00	137.30	139.00	123.00	117.00	115.25	116.60
OPMO%	N/A	N/A	N/A	0.43	0.34	0.35	0.35	0.31	0.33
Depl. DUW/MO	N/A	N/A	N/A	15.32	16.66	16.47	16.65	14.67	18.77
Depl. OPTEMPO multiplier	N/A	N/A	N/A	0.88	0.96	0.95	0.96	0.85	1.08
Depl. DUW Burn Rate	N/A	N/A	N/A	283	283	275	126	302	333
Depl. DNUW Burn Rate	N/A	N/A	N/A	78	78	78	78	78	78
Depl. Fuel Price	N/A	N/A	N/A	\$31.08	\$36.96	\$33.60	\$25.20	\$41.16	\$40.32
Not Depl. DUW/MO	N/A	N/A	N/A	8.99	9.12	9.86	9.10	9.85	10.06
Not Depl. OPTEMPO multiplier	N/A	N/A	N/A	0.96	0.98	1.06	0.97	1.06	1.08
Not Depl. DUW Burn Rate	N/A	N/A	N/A	233	227	239	94	232	241
Not Depl. DNUW Burn Rate	N/A	N/A	N/A	5	5	5	5	5	5
Not Depl. Fuel Price	N/A	N/A	N/A	\$31.08	\$36.96	\$33.60	\$25.20	\$41.16	\$40.32
SU Price Growth	N/A	98.80%	98.80%	99.18%	97.30%	99.40%	95.20%	100.50%	133.20%
SR Price Growth	N/A	103.11%	98.87%	107.52%	113.95%	95.63%	98.60%	111.30%	99.99%
SR Incremental Cost	\$0	-\$1,572	-\$1,128	-\$1,716	-\$3,053	-\$2,099	-\$1,669	-\$1,536	\$0
SO Price Growth	N/A	103.11%	98.87%	105.45%	108.19%	100.74%	100.40%	103.90%	101.20%
SO Incremental Cost	\$0	\$0	-\$69	\$0	\$0	\$0	\$0	\$0	\$0

from OP-41 List
 from OP-41 List
 from OP-41 List
 from OP-41 List
 sum row
 from OP-41 List
 from OP-41 List
 determined from calculated inputs,
 informative data, not used
 determined from calculated inputs,
 informative data, not used
 determined from calculated inputs,
 informative data, not used
 calculated from NUJERS data
 calculated from NUJERS data??
 from the model (FY-CL sheet),
 same as predicted (fixed)
 determined from calculated inputs,
 informative data, not used
 determined from calculated inputs,
 informative data, not used
 calculated from NUJERS data
 calculated from NUJERS data??
 from the model (FY-CL sheet),
 same as predicted (fixed)
 from the model (FY-CL sheet)
 from the model (FY-CL-RS sheet)
 from the model (Incremental SR
 sheet)
 from the model (FY-CL-RS sheet)
 from the model (Incremental SO
 sheet)

Predicted Data	1994	1995	1996	1997	1998	1999	2000	2001	2002	
SF	N/A	N/A	N/A	\$13,874	\$16,814	\$14,278	\$3,974	\$15,208	\$15,336	prediction based on the model's methodology
SU	N/A	N/A	N/A	\$4,298	\$4,523	\$3,768	\$3,811	\$3,918	\$5,345	prediction based on the model's methodology
SR	N/A	N/A	N/A	\$13,836	\$14,791	\$12,499	\$13,155	\$14,124	\$16,300	prediction based on the model's methodology
SO	N/A	N/A	N/A	\$8,080	\$8,860	\$8,113	\$7,020	\$7,574	\$8,633	prediction based on the model's methodology
Total Cost	N/A	N/A	N/A	\$40,088	\$44,988	\$38,659	\$27,960	\$40,824	\$45,614	sum row
Ship Year	N/A	N/A	N/A	13.00	12.90	11.00	11.00	11.00	11.00	from different OP-41 Lists
OPMONTH	N/A	N/A	N/A	137.30	139.00	122.00	117.00	115.25	119.90	from different OP-41 Lists
OPMO%	N/A	N/A	N/A	0.27	0.27	0.27	0.27	0.27	0.27	from different models (Burn Rate sheet)
Depl. DUW/MO	N/A	N/A	N/A	16.8	16.8	16.8	16.8	16.8	16.8	from different models (Burn Rate sheet)
Depl. OPTEMPO multiplier	N/A	N/A	N/A	1.00	0.90	1.04	0.88	0.94	0.98	from different models (FY-CL sheet)
Depl. DUW Burn Rate	N/A	N/A	N/A	283	283	275	126	302	287	from different models (Burn Rate sheet)
Depl. DNUW Burn Rate	N/A	N/A	N/A	19	19	19	19	19	19	from different models (Burn Rate sheet)
Depl. Fuel Price	N/A	N/A	N/A	\$31.08	\$36.96	\$33.60	\$25.20	\$41.16	\$40.32	from different models (FY-CL sheet)
Not Depl. DUW/MO	N/A	N/A	N/A	9.5	9.5	9.5	9.5	9.5	9.5	from different models (Burn Rate sheet)
Not Depl. OPTEMPO multiplier	N/A	N/A	N/A	1.06	1.20	1.20	0.99	1.03	1.00	from different models (FY-CL sheet)
Not Depl. DUW Burn Rate	N/A	N/A	N/A	233	227	239	94	232	240	from different models (Burn Rate sheet)
Not Depl. DNUW Burn Rate	N/A	N/A	N/A	5	5	5	5	5	5	from different models (Burn Rate sheet)
Not Depl. Fuel Price	N/A	N/A	N/A	\$31.08	\$36.96	\$33.60	\$25.20	\$41.16	\$40.32	from different models (FY-CL sheet)
SU Price Growth	N/A	N/A	N/A	99.18%	102.80%	99.40%	94.30%	101.60%	132.60%	from different models (FY-CL sheet)
SR Price Growth	N/A	N/A	N/A	107.52%	113.95%	95.63%	98.00%	101.60%	98.40%	from different models (FY-CL-RS sheet)
SR Incremental Cost	N/A	N/A	N/A	-\$1,716	-\$3,053	-\$2,785	-\$2,430	-\$2,048	-\$1,031	from different models (Incremental SR sheet)
SO Price Growth	N/A	N/A	N/A	105.45%	108.19%	100.74%	98.65%	101.74%	98.70%	from different models (FY-CL-RS sheet)
SO Incremental Cost	N/A	N/A	N/A	\$0	\$0	-\$47	\$0	\$12	\$171	from different models (Incremental SO sheet)

CALCULATED INPUTS

Actual Data	1994	1995	1996	1997	1998	1999	2000	2001	2002
Deployed Months	68.14	72.84	69.49	59.13	47.41	42.56	41.02	35.65	38.04
Not-Deployed Months	175.99	162.16	166.51	153.84	159.79	140.26	137.15	137.62	125.67
Maintenance Months	1.32	0.99	0.33	0.16	0.66	0.00	0.66	0.16	0.33
Deployed Days Underway	1,158.00	1,133.00	1,105.00	906.00	790.00	701.00	683.00	523.00	714.00
Deployed Days Not-underway	913.46	1,081.34	1,007.50	891.55	651.26	592.82	564.01	560.76	442.42
Not-Deployed Days Underway	1,682.00	1,598.00	1,459.00	1,383.00	1,458.00	1,383.00	1,248.00	1,356.00	1,264.00
Not-Deployed Days Not-Underway	3,668.10	3,331.66	3,602.90	3,293.74	3,399.62	2,880.90	2,921.36	2,827.65	2,566.37

~ derived from NUERS data
 ~ derived from NUERS data
 ~ derived from NUERS data
 ~ derived from NUERS data
 ~ = (Deployed Months * 30.4 days) -
 Depl. Days Underway
 ~ derived from NUERS data
 ~ = (Not-Deployed Months * 30.4
 days) - Not-Depl. Days Underway

Predicted Data	1994	1995	1996	1997	1998	1999	2000	2001	2002
Deployed Months	N/A	N/A	N/A	37.48	37.95	33.31	31.94	31.46	32.73
Not-Deployed Months	N/A	N/A	N/A	99.82	101.05	88.69	85.06	83.79	87.17
Maintenance Months	N/A	N/A	N/A	18.70	15.80	10.00	15.00	16.75	12.10
Deployed Days Underway	N/A	N/A	N/A	629.08	573.76	580.24	472.75	497.40	540.78
Deployed Days Not-underway	N/A	N/A	N/A	510.40	579.83	432.26	498.25	459.09	454.30
Not-Deployed Days Underway	N/A	N/A	N/A	1,008.95	1,152.00	1,011.11	801.19	818.26	826.63
Not-Deployed Days Not-Underway	N/A	N/A	N/A	2,025.49	1,920.01	1,685.19	1,784.60	1,728.86	1,823.26

~ = OPMONTH * OPMO%
 ~ = OPMONTH * (1-OPMO%)
 ~ = (Ship Year * 12) - OPMONTH
 ~ = Deployed Months * Depl.
 DUW/MO * Depl. OPTEMPO
 ~ = Deployed Months * (30.4 - (Depl.
 DUW/MO * Depl. OPTEMPO))
 ~ = Not-Deployed Months * Not-
 Depl. DUW/MO * Not-Depl.
 OPTEMPO
 ~ = Not-Deployed Months * (30.4 -
 (Not-Depl. DUW/MO * Not-Depl.
 OPTEMPO))

- missing data, temporary substituted by predicted/actual/previous data
 - calculated value, used for comparison, but not directly in the model

Marked
italic

Fleet	PacFleet
Ship Class	LHA-1CL
Program Element	0204411N
OMN/OMNR	OMN
Resource Sponsor (new)	75
Resource Sponsor (old)	85

Appraisal of Model Accuracy
using backcast: 1997-2002

	Year	SF	SU	SR	SO	Total
Actuals	1997	\$10,512	\$7,679	\$6,698	\$5,025	\$29,914
	1998	\$20,530	\$4,964	\$5,088	\$8,134	\$38,716
	1999	\$16,558	\$5,828	\$5,361	\$9,103	\$36,850
	2000	\$9,042	\$5,701	\$8,035	\$8,077	\$30,855
	2001	\$14,644	\$5,553	\$7,650	\$9,678	\$37,525
	2002	\$16,394	\$10,019	\$5,226	\$7,563	\$39,202
Predicted from All Actual Data	1997	\$9,288	\$5,009	\$4,226	\$5,936	\$24,459
	1998	\$15,372	\$7,153	\$5,863	\$5,950	\$34,339
	1999	\$13,678	\$5,090	\$5,948	\$7,001	\$31,716
	2000	\$5,776	\$5,931	\$6,372	\$7,622	\$25,701
	2001	\$8,568	\$5,134	\$7,129	\$8,812	\$29,643
	2002	\$13,822	\$9,566	\$7,891	\$9,299	\$40,578
Actual - Pred. Fr Actual	1997	\$1,224	\$2,670	\$2,472	-\$911	\$5,455
	1998	\$5,158	-\$2,189	-\$775	\$2,184	\$4,377
	1999	\$2,880	\$738	-\$587	\$2,102	\$5,134
	2000	\$3,266	-\$230	\$1,663	\$455	\$5,154
	2001	\$6,076	\$419	\$521	\$866	\$7,882
	2002	\$2,572	\$453	-\$2,665	-\$1,736	-\$1,376
Actual - Pred. Fr Actual Actual	1997	11.64%	34.77%	36.91%	-18.13%	18.24%
	1998	25.12%	-44.10%	-15.24%	26.85%	11.30%
	1999	17.40%	12.67%	-10.94%	23.09%	13.93%
	2000	36.12%	-4.03%	20.70%	5.64%	16.71%
	2001	41.49%	7.54%	6.82%	8.95%	21.00%
	2002	15.69%	4.52%	-51.00%	-22.95%	-3.51%
MAPE* =		24.58%	17.94%	23.60%	17.60%	14.12%

* Mean Absolute Percentage Error (avg of the abs value of errors %)

** SF's MAPE without year 2000 = 22.27%

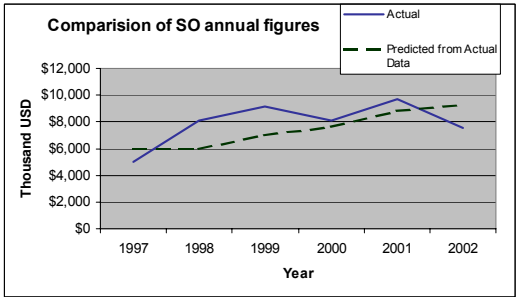
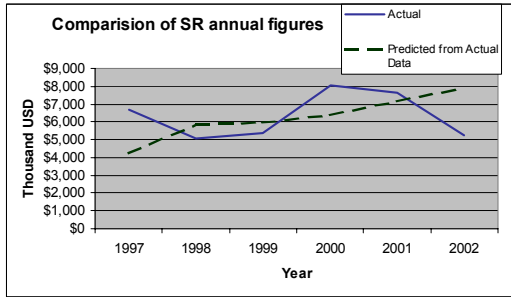
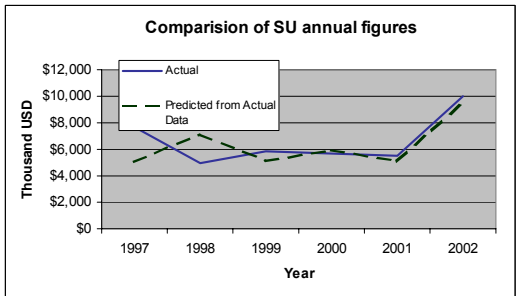
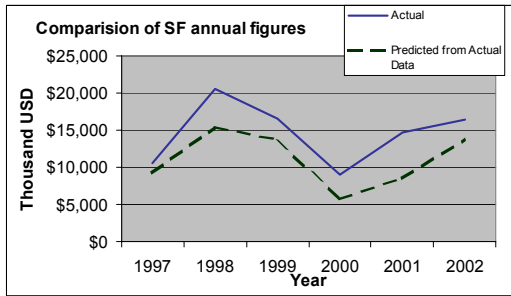
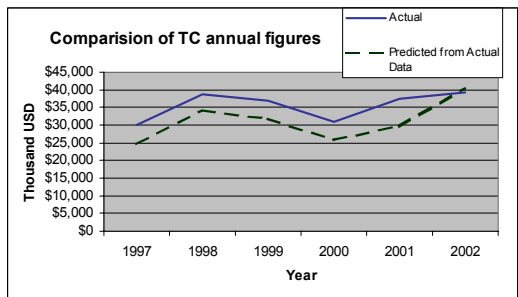
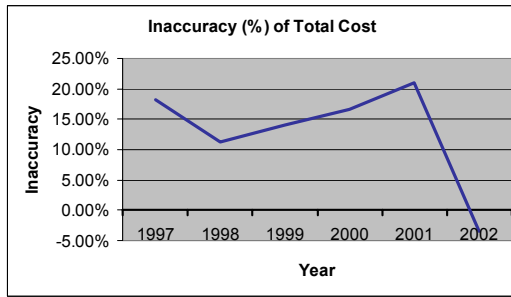
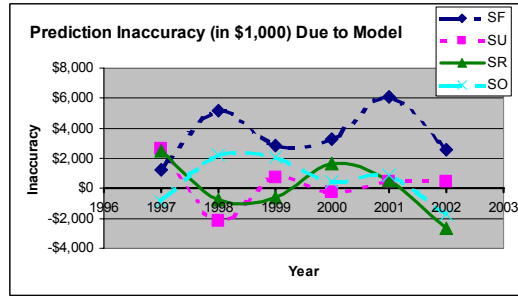
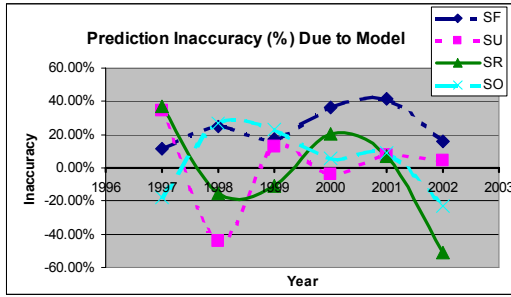

Appraisal of prediction for 2002

Inputs:	PacFleet
Fleet	LHA-1CL
Ship Class	0204411N
Program Element	OMN
OMN/OMNR	75
Resource Sponsor (new)	85
Resource Sponsor (old)	

	SF	SU	SR	SO	Total
Actual	\$16,394	\$10,019	\$5,226	\$7,563	\$39,202
Predicted	\$19,883	\$9,101	\$7,555	\$9,080	\$45,619
Predicted from All Actual Data	\$13,822	\$9,566	\$7,891	\$9,299	\$40,578
Actual - Predicted	-\$3,489	\$918	-\$2,329	-\$1,517	-\$6,417
Actual - Predicted	-\$6,061	\$464	\$336	\$219	-\$5,041
- Pred. fr Actual - Pred. Fr Actual	\$2,572	-\$453	-\$2,665	-\$1,736	-\$1,376

-16.37% -> model total inaccuracy
 -12.86% -> source data inaccuracy
 -3.51% -> model inaccuracy

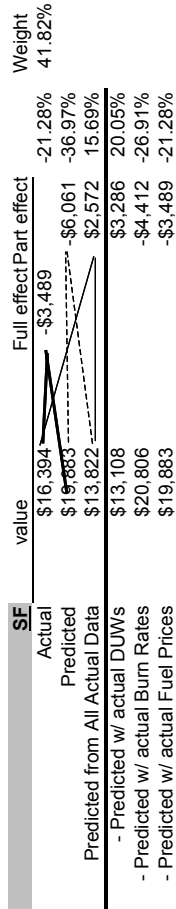

Changed values

Predicted	vs.	Actual	difference%
454	vs.	316	-43.75%
2,242	vs.	2,366	5.23%
40.32	vs.	40.32	0.00%

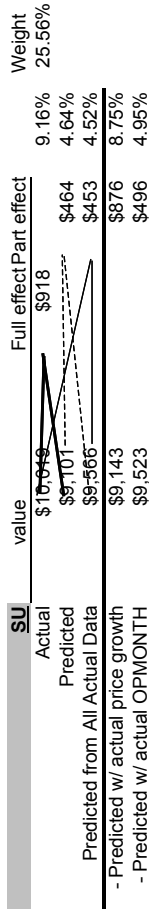

Changed values

Predicted	vs.	Actual	difference%
132.60%	vs.	133.20%	0.45%
32.40	vs.	33.90	4.42%



Changed values

Predicted	vs.	Actual	difference%
98.40%	vs.	99.99%	1.59%
3.00	vs.	3.00	0.00%
-211	vs.	0	#DIV/0!

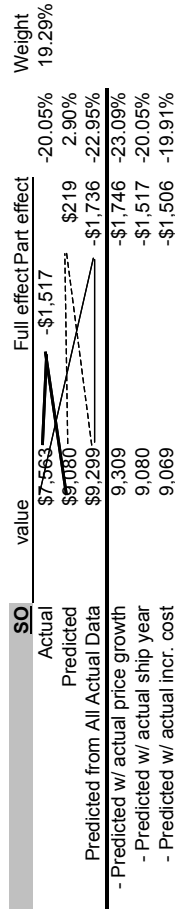

Changed values

Predicted	vs.	Actual	difference%
98.70%	vs.	101.20%	2.47%
3.00	vs.	3.00	0.00%
10	vs.	0	#DIV/0!

How is predicted value calculated for 2022?

SF

Deployed:

DUW

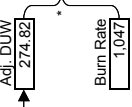
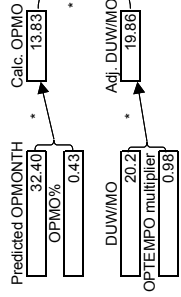

DUW Fuel Cost (in \$1,000) = \$11,602

DNUW

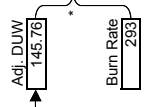
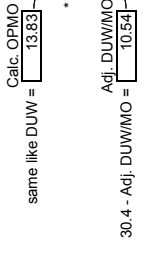

NDUW Fuel Cost (in \$1,000) = \$1,722

Not Deployed:

DUW

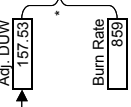
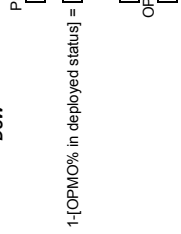

DUW Fuel Cost (in \$1,000) = \$5,456

DNUW

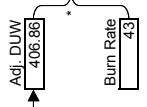
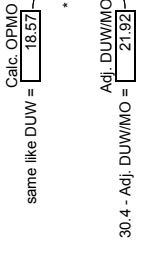

NDUW Fuel Cost (in \$1,000) = \$705

Repair:

DUW

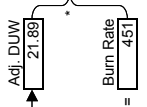
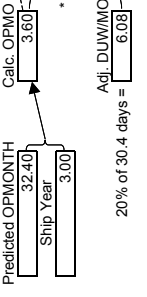

DUW Fuel Cost (in \$1,000) = \$396

SF Cost = \$19,883

SU

	Actual SU Cost	Actual OPMONTH	SU Unit Cost	Actual Price Growths	SU Unit Cost in Year-1 dollar
Year-3	\$5,828	25.1	\$232	95.20% * 100.50%	\$222.15
Year-2	\$5,701	28	\$204	100.50% *	\$204.63
Year-1	\$5,553	26.6	\$209		\$206.76
					Average: \$211.85

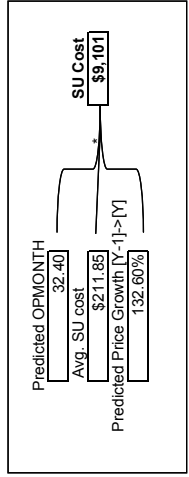

SR

	(Actual SR Cost - Incr. Cost) / Ship Yr	SR Unit Cost	Actual Price Growths	SR Unit Cost in Year-1 dollar
Year-3	\$5,361 / -763 = 3.00	\$2,041	98.60% * 111.30%	\$2,240.20
Year-2	\$8,035 / -149 = 3.00	\$2,728	111.30% *	\$3,036.28
Year-1	\$7,650 / -196 = 3.00	\$2,615		\$2,615.33
				Average: \$2,630.60

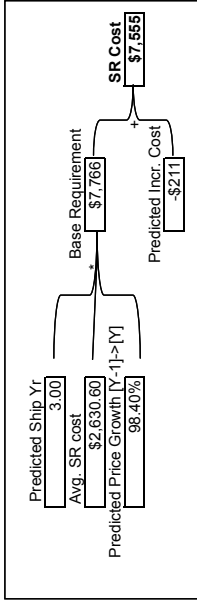

SO

	(Actual SO Cost - Incr. Cost) / Ship Yr	SO Unit Cost	Actual Price Growths	SO Unit Cost in Year-1 dollar
Year-3	\$9,103 / 0 = 3.00	\$3,034	100.40% * 103.90%	\$3,165.28
Year-2	\$8,077 / 0 = 3.00	\$2,692	103.90% *	\$2,797.33
Year-1	\$9,678 / 0 = 3.00	\$3,226		\$3,226.00
				Average: \$3,062.87

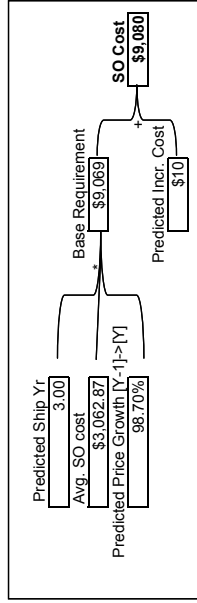

How is predicted value from actual data calculated for 2022

SF

Deployed:

DUW

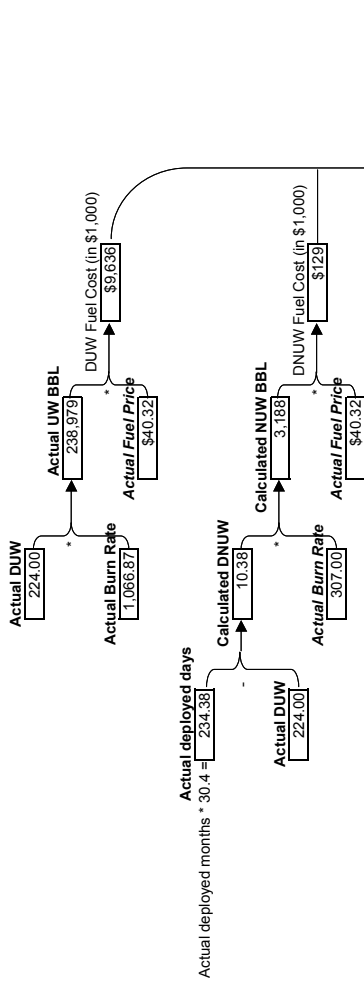

DNUW

Not Deployed:

DUW

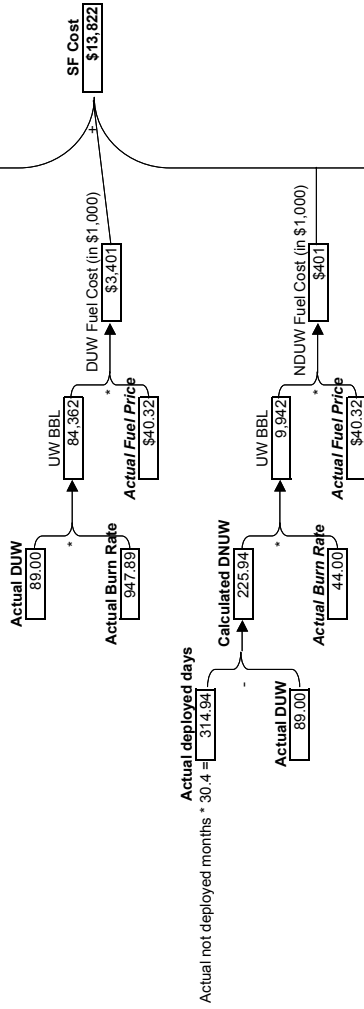

DNUW

Repair:

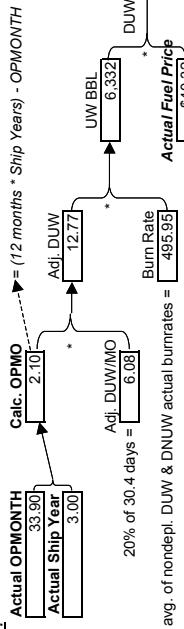

SF Cost

\$13,822

SU

	Actual SU Cost	Actual OPMONTH	SU Unit Cost	Actual Price Growths	SU Unit Cost in Year-1 dollar
Year-3	\$5,828	25.1	\$232	95.20% * 100.50%	\$222.15
Year-2	\$5,701	28	\$204	*	\$204.63
Year-1	\$5,553	26.6	\$209	*	\$206.76
					Average: \$211.85

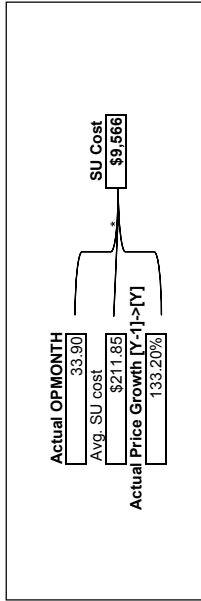

SR

	(Actual SR Cost - Incr.Cost) / Ship Yr	SR Unit Cost	Actual Price Growths	SR Unit Cost in Year-1 dollar
Year-3	\$5,361 / -763 = 3.00	\$2,041	98.60% * 111.30%	\$2,240.20
Year-2	\$8,035 / -149 = 3.00	\$2,728	*	\$3,086.28
Year-1	\$7,650 / -196 = 3.00	\$2,615	*	\$2,615.33
				Average: \$2,630.60

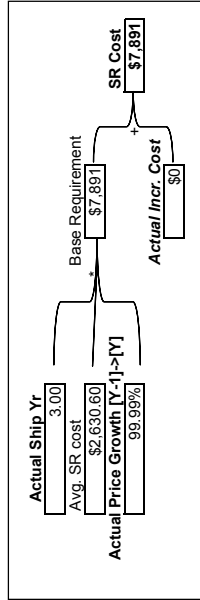

SO

	(Actual SO Cost - Incr.Cost) / Ship Yr	SO Unit Cost	Actual Price Growths	SO Unit Cost in Year-1 dollar
Year-3	\$9,103 / 0 = 3.00	\$3,034	100.40% * 103.90%	\$3,165.28
Year-2	\$8,077 / 0 = 3.00	\$2,692	*	\$2,797.33
Year-1	\$9,678 / 0 = 3.00	\$3,226	*	\$3,226.00
				Average: \$3,062.87

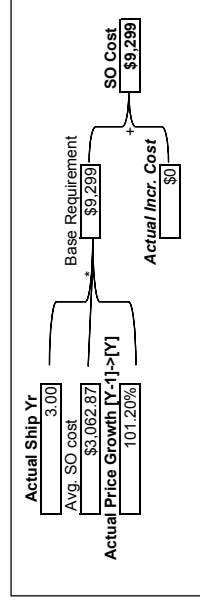

Inputs:
 PacFleet
 Fleet
 Ship Class
 Program Element
 OMN/OMNR
 Resource Sponsor (new)
 Resource Sponsor (old)

LHA-1CL
 0204411N
 OMN
 75
 85

PRIMARY INPUTS

Actual Data	1994	1995	1996	1997	1998	1999	2000	2001	2002
SF	\$11,723	\$14,022	\$18,348	\$10,512	\$20,530	\$16,558	\$9,042	\$14,644	\$16,394
SU	\$3,287	\$7,060	\$6,134	\$7,679	\$4,964	\$5,828	\$5,701	\$5,553	\$10,019
SR	\$4,494	\$3,430	\$5,054	\$6,698	\$5,088	\$5,361	\$8,035	\$7,650	\$5,226
SO	\$5,948	\$4,598	\$6,440	\$5,025	\$8,134	\$9,103	\$8,077	\$9,678	\$7,563
Total Cost	\$25,452	\$29,110	\$35,976	\$29,914	\$38,716	\$36,850	\$30,855	\$37,525	\$39,202
Ship Year	3.00	3.00	3.00	3.00	3.00	3.00	3.00	3.00	3.00
OP/MONTH	24.00	28.00	34.00	26.90	31.00	25.10	28.00	26.60	33.90
OP/MO%	N/A	N/A	N/A	0.46	0.53	0.59	0.43	0.04	0.23
Depl. DUW/MO	N/A	N/A	N/A	7.68	14.00	15.63	14.55	26.55	29.05
Depl. OPTEMPO multiplier	N/A	N/A	N/A	0.44	0.81	0.90	0.84	1.53	1.68
Depl. DUW Burn Rate	N/A	N/A	N/A	975	1,087	956	642	1,154	1,067
Depl. DNUW Burn Rate	N/A	N/A	N/A	307	307	307	307	307	307
Depl. Fuel Price	N/A	N/A	N/A	\$31.08	\$36.96	\$33.60	\$25.20	\$41.16	\$40.32
Not Depl. DUW/MO	N/A	N/A	N/A	9.79	7.73	10.04	6.45	8.10	8.59
Not Depl. OPTEMPO multiplier	N/A	N/A	N/A	1.05	0.83	1.08	0.69	0.87	0.92
Not Depl. DUW Burn Rate	N/A	N/A	N/A	905	1,006	865	1,159	861	948
Not Depl. DNUW Burn Rate	N/A	N/A	N/A	44	44	44	44	44	44
Not Depl. Fuel Price	N/A	N/A	N/A	\$31.08	\$36.96	\$33.60	\$25.20	\$41.16	\$40.32
SU Price Growth	N/A	98.80%	98.80%	99.18%	97.30%	99.40%	95.20%	100.50%	133.20%
SR Price Growth	N/A	103.11%	98.87%	107.52%	113.95%	95.63%	98.60%	111.30%	99.99%
SR Incremental Cost	\$0	-\$445	-\$421	-\$751	-\$767	-\$763	-\$149	-\$196	\$0
SO Price Growth	N/A	103.11%	98.87%	104.45%	108.19%	100.74%	100.40%	103.90%	101.20%
SO Incremental Cost	\$0	\$0	\$0	\$0	\$0	\$0	\$0	\$0	\$0

from OP-41 List
 from OP-41 List
 from OP-41 List
 from OP-41 List
 sum row
 from OP-41 List
 from OP-41 List
 determined from calculated inputs,
 informative data, not used
 determined from calculated inputs,
 informative data, not used
 determined from calculated inputs,
 informative data, not used
 calculated from NUJERS data
 calculated from NUJERS data??
 from the model (FY-CL sheet),
 same as predicted (fixed)
 determined from calculated inputs,
 informative data, not used
 determined from calculated inputs,
 informative data, not used
 calculated from NUJERS data
 calculated from NUJERS data??
 from the model (FY-CL sheet),
 same as predicted (fixed)
 from the model (FY-CL sheet)
 from the model (FY-CL-RS sheet)
 from the model (Incremental SR
 sheet)
 from the model (FY-CL-RS sheet)
 from the model (Incremental SO
 sheet)

Predicted Data	1994	1995	1996	1997	1998	1999	2000	2001	2002	
SF	N/A	N/A	N/A	\$13,271	\$19,312	\$13,865	\$9,623	\$18,185	\$19,883	prediction based on the model's methodology
SU	N/A	N/A	N/A	\$5,009	\$7,558	\$5,069	\$5,874	\$5,191	\$9,101	prediction based on the model's methodology
SR	N/A	N/A	N/A	\$4,226	\$5,863	\$5,509	\$5,924	\$6,290	\$7,555	prediction based on the model's methodology
SO	N/A	N/A	N/A	\$5,936	\$5,950	\$6,959	\$7,489	\$9,095	\$9,080	prediction based on the model's methodology
Total Cost	N/A	N/A	N/A	\$28,441	\$38,684	\$31,402	\$28,910	\$38,760	\$45,619	sum row
Ship Year	N/A	N/A	N/A	3.00	3.00	3.00	3.00	3.00	3.00	from different OP-41 Lists
OPMONTH	N/A	N/A	N/A	26.90	31.00	25.00	28.00	26.60	32.40	from different OP-41 Lists
OPMO%	N/A	N/A	N/A	0.43	0.43	0.43	0.43	0.43	0.43	from different models (Burn Rate sheet)
Depl. DUW/MO	N/A	N/A	N/A	20.2	20.2	20.2	20.2	20.2	20.2	from different models (Burn Rate sheet)
Depl. OPTEMPO multiplier	N/A	N/A	N/A	1.00	0.90	1.04	0.88	0.94	0.98	from different models (FY-CL sheet)
Depl. DUW Burn Rate	N/A	N/A	N/A	975	1,087	956	642	1,154	1,047	from different models (Burn Rate sheet)
Depl. DNUW Burn Rate	N/A	N/A	N/A	293	293	293	293	293	293	from different models (Burn Rate sheet)
Depl. Fuel Price	N/A	N/A	N/A	\$31.08	\$36.96	\$33.60	\$25.20	\$41.16	\$40.32	from different models (FY-CL sheet)
Not Depl. DUW/MO	N/A	N/A	N/A	8.5	8.5	8.5	8.5	8.5	8.5	from different models (Burn Rate sheet)
Not Depl. OPTEMPO multiplier	N/A	N/A	N/A	1.06	1.20	1.20	0.99	1.03	1.00	from different models (FY-CL sheet)
Not Depl. DUW Burn Rate	N/A	N/A	N/A	905	1,006	865	1,159	861	859	from different models (Burn Rate sheet)
Not Depl. DNUW Burn Rate	N/A	N/A	N/A	43	43	43	43	43	43	from different models (Burn Rate sheet)
Not Depl. Fuel Price	N/A	N/A	N/A	\$31.08	\$36.96	\$33.60	\$25.20	\$41.16	\$40.32	from different models (FY-CL sheet)
SU Price Growth	N/A	N/A	N/A	99.18%	102.80%	99.40%	94.30%	101.60%	132.60%	from different models (FY-CL sheet)
SR Price Growth	N/A	N/A	N/A	107.52%	113.95%	95.63%	98.00%	101.60%	98.40%	from different models (FY-CL-RS sheet)
SR Incremental Cost	N/A	N/A	N/A	-\$751	-\$767	-\$1,202	-\$557	-\$396	-\$211	from different models (Incremental SR sheet)
SO Price Growth	N/A	N/A	N/A	104.45%	108.19%	100.74%	98.65%	101.74%	98.70%	from different models (FY-CL-RS sheet)
SO Incremental Cost	N/A	N/A	N/A	\$0	\$0	-\$42	\$0	\$466	\$10	from different models (Incremental SO sheet)

CALCULATED INPUTS

Actual Data	1994	1995	1996	1997	1998	1999	2000	2001	2002
Deployed Months	17.12	12.00	17.00	12.50	16.50	14.84	12.03	1.13	7.71
Not-Deployed Months	6.88	9.48	4.00	9.40	7.50	9.16	3.41	18.39	10.36
Maintenance Months	0.00	0.33	0.00	0.33	0.00	0.00	0.00	0.00	0.49
Deployed Days Underway	243.00	174.00	237.00	96.00	231.00	232.00	175.00	30.00	224.00
Deployed Days Not-underway	277.45	190.80	279.80	284.00	270.60	219.14	190.71	4.35	10.38
Not-Deployed Days Underway	86.00	110.00	42.00	92.00	58.00	92.00	22.00	149.00	89.00
Not-Deployed Days Not-Underway	123.15	178.19	79.60	193.76	170.00	186.46	81.66	410.06	225.94

~ derived from NUERS data
 ~ derived from NUERS data
 ~ derived from NUERS data
 ~ derived from NUERS data
 ~ = (Deployed Months * 30.4 days) -
 Depl. Days Underway
 ~ derived from NUERS data
 ~ = (Not-Deployed Months * 30.4
 days) - Not-Depl. Days Underway

Predicted Data	1994	1995	1996	1997	1998	1999	2000	2001	2002
Deployed Months	N/A	N/A	N/A	11.49	13.24	10.68	11.96	11.36	13.83
Not-Deployed Months	N/A	N/A	N/A	15.41	17.76	14.33	16.04	15.24	18.57
Maintenance Months	N/A	N/A	N/A	9.10	5.00	11.00	8.00	9.40	3.60
Deployed Days Underway	N/A	N/A	N/A	231.79	240.65	223.61	212.77	215.90	274.82
Deployed Days Not-underway	N/A	N/A	N/A	117.39	161.76	100.91	150.69	129.39	145.76
Not-Deployed Days Underway	N/A	N/A	N/A	139.40	181.18	146.12	135.21	133.18	157.53
Not-Deployed Days Not-Underway	N/A	N/A	N/A	329.17	358.81	289.37	352.52	330.17	406.86

~ = OPMONTH * OPMO%
 ~ = OPMONTH * (1-OPMO%)
 ~ = (Ship Year * 12) - OPMONTH
 ~ = Deployed Months * Depl.
 DUW/MO * Depl. OPTEMPO
 ~ = Deployed Months * (30.4 - (Depl.
 DUW/MO * Depl. OPTEMPO))
 ~ = Not-Deployed Months * Not-
 Depl. DUW/MO * Not-Depl.
 OPTEMPO
 ~ = Not-Deployed Months * (30.4 -
 (Not-Depl. DUW/MO * Not-Depl.
 OPTEMPO))

- missing data, temporary substituted by predicted/actual/previous data
 - calculated value, used for comparison, but not directly in the model

Marked
italic

THIS PAGE INTENTIONALLY LEFT BLANK

APPENDIX C: SUMMARY OF SIGNIFICANT REGRESSIONS WITH MAPE

This appendix is a summary of significant regressions, subdivided by Other Consumables (SO) and Repair Parts (SR). The corresponding MAPE for each regression equation is included. The MAPE was obtained by comparing the error produced by the predictive regression and the actual costs, as discussed in Chapter 4. These regressions were the only regressions considered for inclusion in the modified model developed in Chapter V.

Dependent Variables	
SR	A dependent variable to estimate repair parts costs for a ship in the class when using “by hull” data.
SO	A dependent variable to estimate SO for a ship in the class consumable costs for a ship in the class when using “by hull” data.
SR per ship	A dependent variable to estimate SR costs when using class data.
SO per ship	A dependent variable to estimate SO costs when using class data.
Independent Variables	
FY	An independent variable representing the current fiscal year. Fiscal Year 2000 was used as the base (00). Therefore fiscal year 1999 is represented by a negative one (-1) and fiscal year 2001 by a positive one (1).
Pac Flt	A binary (one or zero) indicator variable to represent the fleet in which a ship is home ported. A ship assigned to the Atlantic Fleet would have a value of zero and one assigned to the Pacific Fleet would have a value of one.
UW not dep	Represents the days spent underway and while not in a deployed status. In the NUERS database this is represented by the time spent in code eight.
Code 17	Represents the days underway on deployment while in the 5 th Fleet AOR. This time is represented by code 17 in the NUERS database.
UW dep not 17	Represents the days spent underway and on deployment when operating in areas SO than the 5 th fleet AOR. This is represented by the code nine in the NUERS database.
Total UW deployed	Is the summation of the days under “Code 17” and “Total UW deployed.” This represents the total number of days underway while in a deployed status.
Total UW	Represents the total number of days a ship was underway in a year. It is the summation of the time spent in codes eight, nine and seventeen in the NUERS database.
Total UW / SY	The total days underway for a class during a year divided by the ship years. This represents the average number of days underway per ship.

Table 21: List of Variables Used in the Regressions in Appendix C

AOE-1 Class

SO

By Hull

There were no significant regressions for SO as a dependent variable. No regressions met the 90% significance threshold. This was true for all AOE-1 class ships combined, as well as separated by fleet.

By Class

There are two regressions that meet the 90% significance level for determining SO per ship for the AOE-1 class.

One regression was found to be significant based on combined LANT and PAC data:

$$\text{SO/Ship} = 1427.723 + 98.71429 \text{ FY}$$

$$\text{MAPE} = 25.4\%$$

One regression was found to be significant based only on LANT data:

$$\text{SO/Ship} = 1428.232 + 75.01786 \text{ FY}$$

$$\text{MAPE} = 11.9\%$$

SR

By Hull

Two regressions were found to be significant for the entire class for this Special Interest Item. They are:

$$\text{SR} = 1179276 + 194205 \text{ FY} - 447725 \text{ Pac Flt} + 2952 \text{ Total UW}$$

$$\text{MAPE} = 27.9\%$$

$$\text{SR} = 1582192 + 210046 \text{ FY} - 446790 \text{ Pac Flt}$$

$$\text{MAPE} = 19.6\%$$

Two regressions were found to be significant for the AOE-1 class ships assigned to the Atlantic Fleet. They are:

$$\text{SR} = 1216456 + 168466 \text{ FY} + 2679 \text{ Total UW}$$

MAPE 9.8%

$$\text{SR} = 1582192 + 174494 \text{ FY}$$

MAPE 12.0%

One regression was found to be significant for the Pacific Fleet. It is:

$$\text{SR} = 1099850 + 281150 \text{ FY}$$

MAPE 27.2%

By Class

There is no statistically significant relationship to predict SR cost for the AOE-1 class.

AOE-6 Class

SO

By Hull

Two regressions were found to be significant for the entire class for this Special Interest Item. They are:

$$\text{SO} = 230024 + 585647 \text{ Pac Flt} + 3912 \text{ Total UW}$$

MAPE = 19.9%

$$\text{SO} = - 7758 + 577636 \text{ Pac Flt} + 7567 \text{ UW not dep} + 3842 \text{ Total UW deployed}$$

MAPE = 21.7%

Three regressions were found to be significant for the AOE-6 class ships assigned to the Atlantic Fleet. They are:

$$\text{SO} = 389230 - 95086 \text{ FY} + 2493 \text{ Total UW}$$

MAPE = 15.1%

$$\text{SO} = 700259 - 121495 \text{ FY}$$

MAPE = 34.6%

$$\text{SO} = 315716 + 3238 \text{ Total UW}$$

MAPE = 18.4%

No regressions were found to be significant for the AOE-6 class ships assigned to the Pacific Fleet.

By Class

Only one regression equation is significant at 90% for the AOE-6 class.

Based on PAC data:

$$\begin{aligned} \text{SO per ship} &= 1445 + 173.8571 \text{ FY} \\ \text{MAPE} &= 39.8\% \end{aligned}$$

SR

By Hull

One regression was significant for SR for the entire class of ships. It is:

$$\begin{aligned} \text{SR} &= 461317 - 290374 \text{ Pac Flt} + 10861 \text{ UW not dep} + 5132 \text{ Total UW} \quad \text{deployed} \\ \text{MAPE} &= 14.7\% \end{aligned}$$

No regressions were significant for the Atlantic or Pacific Fleet ships when considered separately.

By Class

We determined multiple relationships that can be used to predict SR cost for AOE-6 class ships.

One regression was found to be significant using combined data:

$$\begin{aligned} \text{SR per ship} &= 1645.112 + 75.20677 \text{ FY} - 614.088 \text{ Pac Flt} \\ \text{MAPE} &= 26.0\% \end{aligned}$$

One regression was found to be significant using LANT data:

$$\begin{aligned} \text{SR per ship} &= 1667.023 + 92.30497 \text{ FY} \\ \text{MAPE} &= 12.6\% \end{aligned}$$

ARS Class

SO

By Hull

One regression was significant for the combined data for this class:

$$\text{SO} = 349315 + 69185 \text{ FY} + 181906 \text{ Pac Flt}$$
$$\text{MAPE} = 18.6\%$$

One regression was significant for the Pacific Fleet data for this class:

$$\text{SO} = 498460 + 134705 \text{ FY}$$
$$\text{MAPE} = 13.1\%$$

One regression that was significant for the Atlantic Fleet data for this class:

$$\text{SO} = 349315 + 36424 \text{ FY}$$
$$\text{MAPE} = 13.0$$

By Class

Several regressions met the threshold of 90% significance.

Two regressions were found to be significant based on Combined data:

$$\text{SO per ship} = 589.383 + 46.69583 \text{ FY}$$
$$\text{MAPE} = 28.6\%$$

$$\text{SO per ship} = 473.4271 + 46.69583 \text{ FY} + 231.9125 \text{ Pac Flt}$$
$$\text{MAPE} = 11.8\%$$

One regression was found to be significant based on LANT data:

$$\text{SO per ship} = 469.818 + 45.26488 \text{ FY}$$
$$\text{MAPE} = 7\%$$

One regression was found to be significant based on PAC data:

$$\text{SO per ship} = 708.969 + 48.14762 \text{ FY}$$
$$\text{MAPE} = 16.4\%$$

SR

By Hull

There was one regression that was significant when the ARS class was considered as a whole:

$$\text{SR} = 414091 + 57674 \text{ FY} + 252672 \text{ Pac Flt}$$
$$\text{MAPE} = 13.6\%$$

One regression was significant for the Atlantic Fleet ships of ARS class when considered separately:

$$\text{SR} = 414091 + 48712 \text{ FY}$$
$$\text{MAPE} = 11.9\%$$

There were no significant regressions for the ARS class when the Pacific Fleet was considered separately.

By Class

Several relationships were determined for predicting SR cost per ship.

Three regressions were found to be significant using combined data:

$$\text{SR per ship} = 408.1503 + 49.92262 \text{ FY} + 259.3275 \text{ Pac Flt}$$
$$\text{MAPE} = 29.6\%$$

$$\text{SR per ship} = 537.814 + 49.92262 \text{ FY}$$
$$\text{MAPE} = 37.4\%$$

$$\text{SR per ship} = -78.593 + 66.767 \text{ FY} + 281.541 \text{ Pac Flt} + 5.6568 \text{ Total UW / SY}$$
$$\text{MAPE} = 25.6\%$$

One regression was found to be significant using PAC data:

$$\text{SR per ship} = 750.9513 + 79.97202 \text{ FY}$$
$$\text{MAPE} = 19.5\%$$

CG-47 Class

SO

By Hull

Four regressions were found to be significant for the entire class for this Special Interest Item. They are:

$$\text{SO} = 589434 + 86589 \text{ FY} + 1312 \text{ Total UW}$$
$$\text{MAPE} = 19.0\%$$

$$\text{SO} = 519990 + 70221 \text{ FY} + 244877 \text{ Pac Flt} + 1061 \text{ Total UW}$$
$$\text{MAPE} = 14.3\%$$

$$\text{SO} = 648018 + 72977 \text{ FY} + 255457 \text{ Pac Flt}$$
$$\text{MAPE} = 14.7\%$$

$$\text{SO} = 753079 + 90914 \text{ FY}$$
$$\text{MAPE} = 20.25\%$$

Three regressions were found to be significant for the ships of the Atlantic Fleet when considered separately:

$$\text{SO} = 545267 + 65314 \text{ FY} + 973 \text{ UW not dep} + 599 \text{ Total UW Deployed}$$
$$\text{MAPE} = 20.1\%$$

$$\text{SO} = 566698 + 65111 \text{ FY} + 674 \text{ Total UW}$$
$$\text{MAPE} = 15.4\%$$

$$\text{SO} = 648018 + 66954 \text{ FY}$$
$$\text{MAPE} = 15.1\%$$

Two regressions were found to be significant for the ships of the Pacific Fleet when considered separately:

$$\text{SO} = 667532 + 81913 \text{ FY} + 1754 \text{ Total UW}$$
$$\text{MAPE} = 36.2$$

$$\text{SO} = 896989 + 85948 \text{ FY}$$
$$\text{MAPE} = 17.1\%$$

By Class

The only regression to meet the 90% significance level is for LANT ships. Using only LANT data:

$$\text{SO per ship} = 868.7925 + 36.67772 \text{ FY}$$
$$\text{MAPE} = 6.4\%$$

SR

By Hull

Six regressions were found to be significant for the entire class for this Special Interest Item. They are:

$$\text{SR} = 2274423 + 279975 \text{ FY} + 3268 \text{ UW not dep} + 2655 \text{ Total UW Deployed}$$
$$\text{MAPE} = 13.2\%$$

$$\text{SR} = 2351259 + 290770 \text{ FY} - 171724 \text{ Pac Flt} + 3011 \text{ UW not dep}$$
$$+ 2896 \text{ Total UW Deployed}$$
$$\text{MAPE} = 13.0\%$$

$$\text{SR} = 2309035 + 279134 \text{ FY} + 2736 \text{ Total UW}$$
$$\text{MAPE} = 13.4\%$$

$$\text{SR} = 2358455 + 290782 \text{ FY} - 174269 \text{ Pac Flt} + 2914 \text{ Total UW}$$
$$\text{MAPE} = 13.1\%$$

$$\text{SR} = 2650403 + 288156 \text{ FY}$$
$$\text{MAPE} = 14.0\%$$

$$\text{SR} = 2710122 + 298352 \text{ FY} - 145208 \text{ Pac Flt}$$
$$\text{MAPE} = 13.8\%$$

Three regressions were found to be significant for the ships of the Atlantic Fleet when considered separately:

$$\text{SR} = 2363303 + 314474 \text{ FY} + 3231 \text{ UW not dep} + 2131 \text{ Total UW Deployed}$$
$$\text{MAPE} = 14.1\%$$

$$\text{SR} = 2426207 + 313876 \text{ FY} + 2353 \text{ Total UW}$$
$$\text{MAPE} = 14.3\%$$

$$\text{SR} = 2710122 + 320313 \text{ FY}$$
$$\text{MAPE} = 14.5\%$$

Three regressions were found to be significant for the ships of the Pacific Fleet when considered separately:

$$\text{SR} = 2107506 + 242910 \text{ FY} + 3367 \text{ UW not dep} + 3944 \text{ Total UW Deployed}$$
$$\text{MAPE} = 11.2\%$$

$$\text{SR} = 2078288 + 242080 \text{ FY} + 3901 \text{ Total UW}$$
$$\text{MAPE} = 11.2\%$$

$$\text{SR} = 2588564 + 251053 \text{ FY}$$
$$\text{MAPE} = 13.0\%$$

By Class

One regression was found to be significant using combined data:

$$\text{SR per ship} = 2522.16 + 100.954 \text{ FY}$$
$$\text{MAPE} = 15.9\%$$

One regression was found to be significant using PAC data:

$$\text{SR per ship} = 2588.568 + 178.6614 \text{ FY}$$
$$\text{MAPE} = 16.7\%$$

CVN-68 Class

SO

By Hull

Two regressions were found to be significant for the ships of the Atlantic Fleet when considered separately:

$$\text{SO} = 5204351 + 781017 \text{ FY} + 20101 \text{ Total UW}$$
$$\text{MAPE} = 16.2\%$$

$$\text{SO} = 4575298 + 23681 \text{ Total UW}$$
$$\text{MAPE} = 18.6$$

By Class

There are no regressions that meet the 90% significance level for predicting SO cost per ship in the CVN-68 class.

SR

By Hull

Five regressions were found to be significant for the ships of the Atlantic Fleet when considered separately:

$$\text{SR} = 2977027 + 681646 \text{ FY} + 29933 \text{ UW not dep} + 21332 \text{ Total UW deployed}$$
$$\text{MAPE} = 27.0\%$$

$$\text{SR} = 3332599 + 731389 \text{ FY} + 23395 \text{ Total UW}$$
$$\text{MAPE} = 26.9\%$$

$$\text{SR} = 2977027 + 681646 \text{ FY} + 29933 \text{ UW not dep} + 21332 \text{ Total UW deployed}$$
$$\text{MAPE} = 27.0\%$$

$$\text{SR} = 6472983 + 986941 \text{ FY}$$
$$\text{MAPE} = 30.4\%$$

$$\text{SR} = 2743518 + 26748 \text{ Total UW}$$
$$\text{MAPE} = 27.4\%$$

By Class

We found no significant relationship between operational factors and SR cost for the CVN-68 class. Further, we found no significant relationship between SR cost and the FY.

DD-963 Class

SO

By Hull

Three regressions were found to be significant for the entire class for this Special Interest Item. They are:

$$\text{SO} = 541424 + 46157 \text{ FY} + 415501 \text{ Pac Flt}$$
$$\text{MAPE} = 17.7\%$$

$$\text{SO} = 331935 + 43634 \text{ FY} + 372565 \text{ Pac Flt} + 1856 \text{ UW not dep} + 1859 \text{ Total UW Deployed.}$$
$$\text{MAPE} = 22.8$$

$$\text{SO} = 327688 + 43430 \text{ FY} + 375341 \text{ Pac Flt} + 1884 \text{ UW not dep} + 2017 \text{ UW Dep not 17} + 1673 \text{ Code 17}$$
$$\text{MAPE} = 19.5\%$$

Two regressions were found to be significant for the ships of the Atlantic Fleet when considered separately:

$$\text{SO} = 455668 + 39223 \text{ FY} + 749 \text{ Total UW}$$
$$\text{MAPE} = 16.9\%$$

$$\text{SO} = 540313 + 40771 \text{ FY}$$
$$\text{MAPE} = 16.1\%$$

Three regressions were found to be significant for the ships of the Pacific Fleet when considered separately:

$$\text{SO} = 384708 + 65132 \text{ FY} + 3927 \text{ UW not dep} + 5179 \text{ UW Dep not 17} + 3310 \text{ Code 17}$$
$$\text{MAPE} = 15.9\%$$

$$\text{SO} = 418276 + 60375 \text{ FY} + 3897 \text{ Total UW}$$
$$\text{MAPE} = 16.0\%$$

$$\text{SO} = 448379 + 3882 \text{ Total UW}$$
$$\text{MAPE} = 17.7\%$$

By Class

There are three regressions that are significant at the 90% threshold.

One regression was found to be significant using combined data:

$$\text{SO per ship} = 876.4264 + 42.34407 \text{ FY}$$
$$\text{MAPE} = 14.4\%$$

One regression was found to be significant using only LANT data:

$$\text{SO per ship} = 754.3822 + 18.24094 \text{ FY}$$
$$\text{MAPE} = 6.0\%$$

One regression was found to be significant using only PAC data:

$$\text{SO per ship} = 998.5156 + 66.45065 \text{ FY}$$
$$\text{MAPE} = 17.8\%$$

SR

By Hull

Three regressions were found to be significant for the entire class for this Special Interest Item. They are:

$$\text{SR} = 2071522 + 165560 \text{ FY}$$
$$\text{MAPE} = 21.7$$

$$\text{SR} = 1530061 + 152196 \text{ FY} + 4881 \text{ UW not dep}$$
$$+ 3923 \text{ UW Dep not 17} + 3683 \text{ Code 17}$$
$$\text{MAPE} = 21.2$$

$$\text{SR} = 1532637 + 152182 \text{ FY} + 4860 \text{ UW not dep}$$
$$+ 3807 \text{ Total UW Deployed}$$
$$\text{MAPE} = 22.1$$

Two regressions were found to be significant for the ships of the Atlantic Fleet when considered separately:

$$\text{SR} = 1720829 + 228806 \text{ FY} + 3050 \text{ Total UW}$$
$$\text{MAPE} = 29.4\%$$

$$\text{SR} = 2065330 + 235108 \text{ FY}$$
$$\text{MAPE} = 21.3\%$$

Three regressions were found to be significant for the ships of the Pacific Fleet when considered separately:

$$\text{SR} = 1341095 + 5605 \text{ UW not dep} + 8467 \text{ UW Dep not 17} + 4489 \text{ Code 17}$$
$$\text{MAPE} = 18.4\%$$

$$\text{SR} = 1465298 + 4463 \text{ UW not dep} + 5898 \text{ Total UW Deployed}$$
$$\text{MAPE} = 22.1\%$$

$$\text{SR} = 1398205 + 5716 \text{ Total UW}$$
$$\text{MAPE} = 33.9\%$$

By Class

One regression was found to be significant using combined data:

$$\text{SR per ship} = 2025.46 + 123.3039 \text{ FY}$$
$$\text{MAPE} = 12.7\%$$

One regression was found to be significant using LANT data:

$$\text{SR per ship} = 1958.267 + 65.34286 \text{ FY}$$
$$\text{MAPE} = 4.4\%$$

One regression was found to be significant using PAC data:

$$\text{SR per ship} = 2033.559 + 122.1649 \text{ FY}$$
$$\text{MAPE} = 9.1\%$$

DDG-51 Class

SO

By Hull

Three regressions were found to be significant for the entire class for this Special Interest Item. They are:

$$\text{SO} = 100447 + 41255 \text{ FY} + 190405 \text{ Pac Flt} + 3605 \text{ UW not dep}$$
$$+ 3130 \text{ UW Dep not 17} + 2576 \text{ Code 17}$$
$$\text{MAPE} = 23.9\%$$

$$\text{SO} = 212997 + 51850 \text{ FY} + 2984 \text{ Total UW}$$
$$\text{MAPE} = 24.3\%$$

$$\text{SO} = 151319 + 40916 \text{ FY} + 177117 \text{ Pac Flt} + 2920 \text{ Total UW}$$
$$\text{MAPE} = 25.5$$

Two regressions were found to be significant for the ships of the Atlantic Fleet when considered separately:

$$\text{SO} = 193428 + 49367 \text{ FY} + 3030 \text{ UW not dep} + 1906 \text{ UW Dep not 17}$$
$$+ 1663 \text{ Code 17}$$
$$\text{MAPE} = 21.7\%$$

$$\text{SO} = 246691 + 43832 \text{ FY} + 2107 \text{ Total UW}$$
$$\text{MAPE} 23.3\%$$

Three regressions were found to be significant for the ships of the Pacific Fleet when considered separately:

$$\text{SO} = 126572 + 40860 \text{ FY} + 4890 \text{ UW not dep} + 5099 \text{ Uw Deployed Not 17} + 3320$$
$$\text{Code 17}$$
$$\text{MAPE} = 20.8\%$$

$$\text{SO} = 166433 + 39827 \text{ FY} + 4378 \text{ UW not dep} + 4123 \text{ Total UW Deployed}$$
$$\text{MAPE} = 21.2\%$$

$$\text{SO} = 180099 + 40288 \text{ FY} + 4132 \text{ Total UW}$$
$$\text{MAPE} = 21.2\%$$

By Class

There is one significant regression for DDG-51. It is for LANT ships only.

$$\text{SO per ship} = 711.387 + 18.74133 \text{ FY}$$
$$\text{MAPE} = 6.7\%$$

SR

By Hull

Two regressions were found to be significant for the entire class for this Special Interest Item. They are:

$$\begin{aligned} \text{SR} &= 400753 + 10018 \text{ UW not dep} + 7212 \text{ UW Dep not 17} + 7280 \text{ Code 17} \\ &\quad + 103074 \text{ FY} \\ \text{MAPE} &= 26.5\% \end{aligned}$$

$$\begin{aligned} \text{SR} &= 562075 + 99154 \text{ FY} + 7482 \text{ Total UW} \\ \text{MAPE} &= 26.8 \end{aligned}$$

Three regressions were found to be significant for the ships of the Atlantic Fleet when considered separately:

$$\begin{aligned} \text{SR} &= 429539 + 113649 \text{ FY} + 10825 \text{ UW not dep} + 3968 \text{ UW Dep not 17} \\ &\quad + 6475 \text{ Code 17} \\ \text{MAPE} &= 24.5\% \end{aligned}$$

$$\begin{aligned} \text{SR} &= 392123 + 112791 \text{ FY} + 11212 \text{ UW not dep} \\ &\quad + 5113 \text{ Total UW deployed} \\ \text{MAPE} &= 24.6\% \end{aligned}$$

$$\begin{aligned} \text{SR} &= 674755 + 92003 \text{ FY} + 6475 \text{ Total UW} \\ \text{MAPE} &= 27.2\% \end{aligned}$$

Three regressions were found to be significant for the ships of the Pacific Fleet when considered separately:

$$\begin{aligned} \text{SR} &= 248942 + 10652 \text{ UW not dep} + 11890 \text{ Uw Deployed Not 17} + 6623 \text{ Code 17} \\ &\quad + 120507 \text{ FY} \\ \text{MAPE} &= 23.9\% \end{aligned}$$

$$\begin{aligned} \text{SR} &= 366956 + 9136 \text{ UW not dep} + 9000 \text{ Total UW Deployed} \\ &\quad + 117450 \text{ FY} \\ \text{MAPE} &= 25.2\% \end{aligned}$$

$$\begin{aligned} \text{SR} &= 374250 + 9005 \text{ Total UW} + 117696 \text{ FY} \\ \text{MAPE} &= 25.3\% \end{aligned}$$

By Class

SR cost for the DDG-51 class as a whole demonstrates a significant relationship when the data for each fleet are combined. In this case combined data from LANT and PACFLT DDGs result in an equation that predicts total SR cost at a 95% significance level (5% higher than our threshold). The equation is as follows:

$$\text{SR} = 10,232 + 1322.072 \text{ FY} + 7.137979 \text{ UW not dep} + 4.856984 \text{ Total UW deployed}$$

MAPE = 10.4%

*It should be noted that this equation is for predicting total SR cost for the class not for an individual ship.

Using only LANT data:

$$\text{SR per ship} = 1328 - 98.0074 \text{ FY}$$

MAPE = 8.9%

*Here the negative coefficient for fiscal year describes a decline in cost of SR per ship. This could be due to several factor including learning curve and increased purchasing power with repair part suppliers. Whatever the reason for the trend, users of the model must watch closely to observe any change that would indicate a flattening or increase in SR cost per ship.

FFG Class

SO

By Hull

Three regressions were found to be significant for the entire class for this Special Interest Item. They are:

$$\text{SO} = 253249 + 57776 \text{ FY} + 298451 \text{ Pac Flt} + 1936 \text{ UW not dep}$$

+ 1010 UW Dep not 17 + 1602 Code 17

MAPE = 19.8%

$$\text{SO} = 284174 + 57251 \text{ FY} + 283864 \text{ Pac Flt} + 1494 \text{ Total UW}$$
$$\text{MAPE} = 19.8\%$$

$$\text{SO} = 460315 + 57856 \text{ FY} + 303944 \text{ Pac Flt}$$
$$\text{MAPE} = 19.2\%$$

Two regressions were found to be significant for the ships of the Atlantic Fleet when considered separately:

$$\text{SO} = 465728 + 63906 \text{ FY}$$
$$\text{MAPE} = 17.7\%$$

$$\text{SO} = 395351 + 64795 \text{ FY} + 603 \text{ Total UW}$$
$$\text{MAPE} = 17.4\%$$

Three regressions were found to be significant for the ships of the Pacific Fleet when considered separately:

$$\text{SO} = 399035 + 46848 \text{ FY} + 2818 \text{ Total UW}$$
$$\text{MAPE} = 19.2\%$$

$$\text{SO} = 410151 + 2911 \text{ Total UW}$$
$$\text{MAPE} = 20.0\%$$

$$\text{SO} = 367734 + 3749 \text{ UW not dep} + 2382 \text{ UW Dep} + 3003 \text{ Code 17}$$
$$\text{MAPE} = 20.5\%$$

By Class

For FFG-7, several regressions meet the 90% significance level.

Two regressions were found to be significant using combined data:

$$\text{SO per ship} = 648.587 + 36.86082 \text{ FY} + 111.0003 \text{ Pac Flt}$$
$$\text{MAPE} = 9.9\%$$

$$\text{SO per ship} = 704.0872 + 36.86082 \text{ FY}$$
$$\text{MAPE} = 10.6\%$$

One regression was found to be significant using only LANT data:

$$\text{SO per ship} = 617.0314 + 24.24533 \text{ FY}$$
$$\text{MAPE} = 3.7\%$$

One regression was found to be significant using only PAC data:

$$\text{SO per ship} = 791.12 + 49.47386 \text{ FY}$$
$$\text{MAPE} = 12.9\%$$

SR

By Hull

Two regressions were found to be significant for the entire class for this Special Interest Item. They are:

$$\text{SR} = 1114799 + 117170 \text{ FY} + 3286 \text{ UW not dep}$$
$$+ 1569 \text{ Total UW Deployd}$$
$$\text{MAPE} = 17.5\%$$

$$\text{SR} = 1183994 + 140115 \text{ FY} - 264124 \text{ Pac Flt} + 3278 \text{ UW not dep}$$
$$+ 2182 \text{ Total UW Deployed}$$
$$\text{MAPE} = 16.1\%$$

Three regressions were found to be significant for the ships of the Atlantic Fleet when considered separately:

$$\text{SR} = 1199609 + 189197 \text{ FY} + 3498 \text{ UW not dep} + 1826 \text{ Total UW dep}$$
$$\text{MAPE} = 15.6\%$$

$$\text{SR} = 1265013 + 187084 \text{ FY} + 2496 \text{ Total UW}$$
$$\text{MAPE} = 15.6\%$$

$$\text{SR} = 1556107 + 183410 \text{ FY}$$
$$\text{MAPE} = 15.9\%$$

No regressions were found to be significant for the ships of the Pacific Fleet when considered separately.

By Class

Several regressions of SR cost per ship are significant for the FFG-7 class.

Two regressions were found to be significant using combined data:

$$\text{SR per ship} = 1532.641 + 75.73792 \text{ FY} - 231.313 \text{ Pac Flt}$$
$$\text{MAPE} = 9.4\%$$

$$\text{SR per ship} = 1416.98 + 75.73792 \text{ FY}$$
$$\text{MAPE} = 13.3\%$$

One regression was found to be significant using LANT data:

$$\text{SR per ship} = 1450.977 + 43.07232 \text{ FY}$$
$$\text{MAPE} = 3.0\%$$

One regression was found to be significant using PAC data:

$$\text{SR per ship} = 1328.088 + 53.5 \text{ FY}$$
$$\text{MAPE} = 4.9\%$$

LHA-1 Class

SO

By Hull

Two regressions were found to be significant for the entire class for this Special Interest Item. They are:

$$\text{SO} = 1830385 + 1146365 \text{ Pac Flt}$$
$$\text{MAPE} = 18.0\%$$

One regression was found to be significant for the ships of the Atlantic Fleet when considered separately:

$$\text{SO} = 1830385 + 218112 \text{ FY}$$
$$\text{MAPE} = 18.3\%$$

No regressions were found to be significant for the ships of the Pacific Fleet when considered separately.

By Class

The LHA-1 class provides significant relationships between SO costs and operational data. Significant relationships with operational measures (days underway) exist both in the combined data and the PAC data. In the LANT data, SO per ship is only significant when regressed against FY.

Two regressions were found to be significant using combined data:

$$\text{SO per ship} = 2687.077 + 167.3601 \text{ FY}$$
$$\text{MAPE} = 12.2\%$$

$$\text{SO per ship} = 1530.214 + 155.7285 \text{ FY} + 10.337 \text{ Total UW / SY}$$
$$\text{MAPE} = 12.0\%$$

One regression was found to be significant using LANT data:

$$\text{SO per ship} = 2457.304 + 118.0714 \text{ FY}$$
$$\text{MAPE} = 7.1\%$$

Two regressions were found to be significant using PAC data:

$$\text{SO per ship} = 1442.206 + 184.4804 \text{ FY} + 12.8445 \text{ Total UW / SY}$$
$$\text{MAPE} = 10.5\%$$

$$\text{SO per ship} = 2916.774 + 216.6426 \text{ FY}$$
$$\text{MAPE} = 13.6\%$$

SR

By Hull

No regressions were found to be significant for the entire class for this Special Interest Item.

One regression was found to be significant for the ships of the Atlantic Fleet when considered separately:

$$\text{SR} = 2495823 + 467231 \text{ FY}$$
$$\text{MAPE} = 24.2\%$$

No regressions were found to be significant for the ships of the Pacific Fleet when considered separately:

By Class

One regression was found to be significant using combined data:

$$\text{SR per ship} = 2148.285 + 91.33448 \text{ FY}$$
$$\text{MAPE} = 15.2\%$$

One regression was found to be significant using PAC data:

$$\text{SR per ship} = 2349.507 + 176.3022 \text{ FY}$$
$$\text{MAPE} = 14.4\%$$

LHD Class

SO

By Hull

Two regressions were found to be significant for the entire class for this Special Interest Item. They are:

$$\text{SO} = 1060138 + 591557 \text{ Pac Flt} + 4965 \text{ Total UW}$$
$$\text{MAPE} = 21.1\%$$

$$\text{SO} = 1195299 + 5858 \text{ Total UW}$$
$$\text{MAPE} = 26.3\%$$

One regression was found to be significant for the ships of the Atlantic Fleet when considered separately:

$$\text{SO} = 1109434 + 4534 \text{ Total UW}$$
$$\text{MAPE} = 17.6\%$$

No regressions were found to be significant for the ships of the Pacific Fleet when considered separately.

By Class

In the LHD-1 class several regressions proved significant.

Two regressions were found to be significant using combined data:

$$\text{SO per ship} = 2399.275 + 172.722 \text{ FY} + 447.1553 \text{ Pac Flt}$$
$$\text{MAPE} = 14.7\%$$

$$\text{SO per ship} = 2622.58 + 172.722 \text{ FY}$$
$$\text{MAPE} = 15.6\%$$

One regression was found to be significant using LANT data:

$$\text{SO per ship} = 2281.057 + 125.4181 \text{ FY}$$
$$\text{MAPE} = 9.4\%$$

One regression was found to be significant using PAC data:

$$\text{SO per ship} = 2964.655 + 220.0119 \text{ FY}$$
$$\text{MAPE} = 16.9\%$$

SR

By Hull

Three regressions were found to be significant for the entire class for this Special Interest Item. They are:

$$\text{SR} = 1156393 + 124175 \text{ FY} + 9707 \text{ UW not dep} + 7426 \text{ Total Dep UW}$$
$$\text{MAPE} = 15.3$$

$$\text{SR} = 1290522 + 113189 \text{ FY} + 7522 \text{ Total UW}$$
$$\text{MAPE} = 15.4\%$$

$$\text{SR} = 1025405 + 11963 \text{ UW not dep} + 4940 \text{ UW Dep not 17} + 11242 \text{ Code 17}$$
$$\text{MAPE} 14.8\%$$

Three regressions were found to be significant for the ships of the Atlantic Fleet when considered separately:

$$\text{SR} = 785076 + 16559 \text{ UW not dep} + 4675 \text{ UW Dep not 17} + 13331 \text{ Code 17}$$
$$\text{MAPE} = 12.6\%$$

$$\text{SR} = 827705 + 15099 \text{ UW not dep} + 8581 \text{ Total Dep UW}$$
$$\text{MAPE} = 15.8\%$$

$$\text{SR} = 1196309 + 9152 \text{ Total UW}$$
$$\text{MAPE} = 17.8\%$$

Three regressions were found to be significant for the ships of the Pacific Fleet when considered separately:

$$\text{SR} = 1395677 + 186636 \text{ FY} + 5703 \text{ Total UW}$$
$$\text{MAPE} = 11.5\%$$

$$\text{SR} = 2139293 + 231497 \text{ FY}$$
$$\text{MAPE} = 15.8\%$$

$$\text{SR} = 1396541 + 6391 \text{ Total UW}$$
$$\text{MAPE} = 13.1\%$$

By Class

No significant relationships were developed between SR cost per ship and any of the operational variables we studied. Further, no significant relationship was determined to exist between SR cost per ship and fiscal year.

LPD Class

SO

By Hull

One regression was found to be significant for the entire class for this Special Interest Item. They are:

$$\text{SO} = 459942 + 47618 \text{ FY} + 493034 \text{ Pac Flt} + 2381 \text{ Total UW}$$
$$\text{MAPE} = 15.7\%$$

One regression was found to be significant for the ships of the Atlantic Fleet when considered separately:

$$\text{SO} = 753710 + 49124 \text{ FY}$$
$$\text{MAPE} = 10.3\%$$

Two regressions were found to be significant for the ships of the Pacific Fleet when considered separately:

$$\text{SO} = 691450 + 4762 \text{ Total UW}$$
$$\text{MAPE} = 15.0\%$$

$$\text{SO} = 629996 + 5102 \text{ UW not dep} + 6866 \text{ Uw Deployed not 17} + 3522 \text{ Code 17}$$
$$\text{MAPE} = 14.4\%$$

By Class

LPD-4 class demonstrates significant relationships between SO per ship and FY.

One regression was found to be significant using combined data:

$$\text{SO per ship} = 983.0261 + 48.72044 \text{ FY} + 269.0458 \text{ Pac Flt}$$
$$\text{MAPE} = 28.8\%$$

One regression was found to be significant using PAC data:

$$\text{SO per ship} = 1333.153 + 81.15278 \text{ FY}$$
$$\text{MAPE} = 7.3\%$$

SR

By Hull

Three regressions were found to be significant for the entire class for this Special Interest Item. They are:

$$\text{SR} = 588844 + 87060 \text{ FY} + 3051 \text{ UW not dep} + 1639 \text{ Total Deployed}$$
$$\text{MAPE} = 17.8\%$$

$$\text{SR} = 686844 + 86693 \text{ FY} + 1544 \text{ Total UW}$$
$$\text{MAPE} = 18.2\%$$

$$\text{SR} = 874094 + 89155 \text{ FY}$$
$$\text{MAPE} = 20.0\%$$

One regression was found to be significant for the ships of the Atlantic Fleet when considered separately:

$$\text{SR} = 858139 + 76908 \text{ FY}$$
$$\text{MAPE} = 16.8\%$$

Three regressions were found to be significant for the ships of the Pacific Fleet when considered separately:

$$\text{SR} = 515894 + 95973 \text{ FY} + 3626 \text{ UW not dep} + 2633 \text{ Total Deployed}$$
$$\text{MAPE} = 18.3\%$$

$$\text{SR} = 576194 + 96696 \text{ FY} + 2593 \text{ Total UW}$$
$$\text{MAPE} = 18.5\%$$

$$\text{SR} = 883832 + 102920 \text{ FY}$$
$$\text{MAPE} = 22.6\%$$

By Class

No significant relationships were developed between SR cost per ship and any of the operational variables we studied. Further, no significant relationship was determined to exist between SR cost per ship and fiscal year.

LSD-36 Class

SO

By Hull

Three regressions were found to be significant for the entire class for this Special Interest Item. They are:

$$\text{SO} = 659230 + 175118 \text{ FY} + 400311 \text{ Pac Flt}$$
$$\text{MAPE} = 27.9\%$$

$$\text{SO} = 584179 + 562921 \text{ Pac Flt}$$
$$\text{MAPE} = 29.8\%$$

$$\text{SO} = 869294 + 226643 \text{ FY}$$
$$\text{MAPE} = 27.5\%$$

No regressions were found to be significant for the ships of the Atlantic Fleet when considered separately:

Two regressions were found to be significant for the ships of the Pacific Fleet when considered separately:

$$\text{SO} = -176656 + 10929 \text{ Total UW}$$
$$\text{MAPE} = 22.6\%$$

$$\text{SO} = 1018790 + 256620 \text{ FY}$$
$$\text{MAPE} = 21.2\%$$

By Class

In the LSD-36 class the only regression that meets the 90% significance level is for predicting SO in PAC. The equation is:

$$\text{SO per ship} = 1124.714 + 85.91071 \text{ FY}$$
$$\text{MAPE} = 13.8\%$$

SR

By Hull

One regression was found to be significant for the entire class for this Special Interest Item:

$$\text{SR} = 809213 + 116406 \text{ FY}$$
$$\text{MAPE} = 18.3\%$$

No regressions were found to be significant for the ships of the Atlantic Fleet when considered separately:

Four regressions were found to be significant for the ships of the Pacific Fleet when considered separately:

$$\begin{aligned} \text{SR} &= 132031 + 210208 \text{ FY} + 6168 \text{ UW not dep} + 3274 \text{ UW Dep} \\ &+ 3783 \text{ Code 17} \\ \text{MAPE} &= 3.3\% \end{aligned}$$

$$\begin{aligned} \text{SR} &= 132195 + 210146 \text{ FY} + 6100 \text{ UW not dep} + 3526 \text{ Total Dep UW} \\ \text{MAPE} &= 2.8\% \end{aligned}$$

$$\begin{aligned} \text{SR} &= 313960 + 210862 \text{ FY} + 3385 \text{ Total UW} \\ \text{MAPE} &= 4.9\% \end{aligned}$$

$$\begin{aligned} \text{SR} &= 710695 + 237435 \text{ FY} \\ \text{MAPE} &= 10.6\% \end{aligned}$$

By Class

No significant relationship could be determined to predict SR cost per ship for the LSD-36 class.

LSD-41 Class

SO

By Hull

Two regressions were found to be significant for the entire class for this Special Interest Item. They are:

$$\begin{aligned} \text{SO} &= 574808 + 51171 \text{ FY} + 412390 \text{ Pac Flt} \\ \text{MAPE} &= 22.5 \end{aligned}$$

$$\begin{aligned} \text{SO} &= 384471 + 46986 \text{ FY} + 370971 \text{ Pac Flt} + 1803 \text{ Total UW} \\ \text{MAPE} &= 20.5\% \end{aligned}$$

One regression was found to be significant for the ships of the Atlantic Fleet when considered separately:

$$\text{SO} = 577158 + 85242 \text{ FY}$$

MAPE 24.8

One regression was found to be significant for the ships of the Pacific Fleet when considered separately:

$$\text{SO} = 513888 + 3846 \text{ Total UW}$$

MAPE= 19.0%

By Class

No regressions proved significant for predicting SO cost for the LSD-41 class.

SR

By Hull

One regression was found to be significant for the entire class for this Special Interest Item:

$$\text{SR} = 987132 + 110765 \text{ FY} - 158856 \text{ Pac Flt}$$

MAPE = 26.5

One regression was found to be significant for the ships of the Atlantic Fleet when considered separately:

$$\text{SR} = 988392 + 129041 \text{ FY}$$

MAPE = 22.6%

One regression was found to be significant for the ships of the Pacific Fleet when considered separately:

$$\text{SR} = 881305 - 56488 \text{ FY}$$

MAPE= 17.0%

By Class

No significant relationships were developed between SR cost per ship and any of the operational variables we studied. Further, no significant relationship was determined to exist between SR cost per ship and fiscal year.

MCM Class

SO

By Hull

One regression was found to be significant for the entire class for this Special Interest Item. They are:

$$\text{SO} = 191822 + 22134 \text{ FY} + 604 \text{ Total UW}$$
$$\text{MAPE} = 13.4\%$$

One regression was found to be significant for the ships of the Atlantic Fleet when considered separately:

$$\text{SO} = 216334 + 23261 \text{ FY}$$
$$\text{MAPE} = 9.5\%$$

Two regressions were found to be significant for the ships home-ported in Japan when considered separately:

$$\text{SO} = 270038 + 29781 \text{ FY}$$
$$\text{MAPE} = 8.9\%$$

$$\text{SO} = 173739 + 1187 \text{ Total UW}$$
$$\text{MAPE} = 11.3\%$$

One regression was found to be significant for the ships home-ported in Bahrain when considered separately:

$$\text{SO} = 286603 + 19472 \text{ FY}$$
$$\text{MAPE} = 9.7\%$$

By Class

No significant relationships were developed between SO cost per ship and any of the operational variables we studied. Further, no significant relationship was determined to exist between SO cost per ship and fiscal year.

SR

By Hull

Two regressions were found to be significant for the entire class for this Special Interest Item. They are:

$$\text{SR} = 792553 + 125855 \text{ FY} + 2878 \text{ Total UW}$$
$$\text{MAPE} = 19.9\%$$

$$\text{SR} = 1032911 + 137868 \text{ FY}$$
$$\text{MAPE} = 22.7\%$$

One regression was found to be significant for the ships of the Atlantic Fleet when considered separately:

$$\text{SR} = 980124 + 191390 \text{ FY}$$
$$\text{MAPE} = 17.6\%$$

One regression was found to be significant for the ships homeported in Japan when considered separately:

$$\text{SR} = 903463 + 131279 \text{ FY}$$
$$\text{MAPE} = 13.6\%$$

No regressions were found to be significant for the ships homeported in Bahrain when considered separately:

By Class

No significant relationships were developed between SR cost per ship and any of the operational variables we studied. Further, no significant relationship was determined to exist between SR cost per ship and fiscal year.

MHC Class

SO

By Hull

Two regressions were found to be significant for the entire class for this Special Interest Item. They are:

$$\begin{aligned} \text{SO} &= 191950 + 46602 \text{ FY} \\ \text{MAPE} &= 30.8\% \end{aligned}$$

$$\begin{aligned} \text{SO} &= 66933 + 1605 \text{ Total UW} \\ \text{MAPE} &= 35.1\% \end{aligned}$$

By Class

No significant relationships were developed between SO cost per ship and any of the operational variables we studied. Further, no significant relationship was determined to exist between SO cost per ship and fiscal year.

SR

By Hull

One regression was found to be significant for the entire class for this Special Interest Item. They are:

$$\begin{aligned} \text{SR} &= 492140 + 164273 \text{ FY} \\ \text{MAPE} &= 40.0\% \end{aligned}$$

By Class

No significant relationships were developed between SR cost per ship and any of the operational variables we studied. Further, no significant relationship was determined to exist between SR cost per ship and fiscal year.

THIS PAGE INTENTIONALLY LEFT BLANK

APPENDIX D: SUMMARY OF SHIP CLASS REGRESSION BY CLASS

This appendix details the regressions performed on a “by class” basis. “By class” implies that the costs for a class for an entire year were aggregated into one data point. Complete statistical analysis for each regression is included. Only those regressions that were significant to the ninety percent level for the regression and each independent variable were considered.

The variables

Dependent Variables	
SR/ship	A dependent variable to estimate repair parts costs when using “by class” data.
SO/ship	A dependent variable to estimate SO consumable costs when using “by class” data.
Independent Variables	
FY	An independent variable representing the current fiscal year. Fiscal Year 2000 was used as the base (00). Therefore fiscal year 1999 is represented by a negative one (-1) and fiscal year 2001 by a positive one (1).
Pac Flt	A binary (one or zero) indicator variable to represent the fleet in which a ship is home ported. A ship assigned to the Atlantic Fleet would have a value of zero and one assigned to the Pacific Fleet would have a value of one.
UW not dep	Represents the days spent underway and while not in a deployed status. In the NUERS database this is represented by the time spent in code eight.
Code 17	Represents the days underway on deployment while in the 5 th Fleet AOR. This time is represented by code 17 in the NUERS database.
UW dep not 17	Represents the days spent underway and on deployment when operating in areas SO than the 5 th fleet AOR. This is represented by the code nine in the NUERS database.
Total UW de- ployed	Is the summation of the days under “Code 17” and “Total UW deployed.” This represents the total number of days underway while in a deployed status.
Total UW	Represents the total number of days a ship was underway in a year. It is the summation of the time spent in codes eight, nine and seventeen in the NUERS database.

Table 22: List of Variables Used in Regressions in Appendix D

AOE 1 Class

Regression Analysis: SO/ship versus FY2 (AOE 1 - Combined) MAPE = 25.4%

The regression equation is
SO/ship = 1428 + 98.7 FY2

Predictor	Coef	SE Coef	T	P
Constant	1427.7	119.9	11.91	0.000
FY2	98.71	35.36	2.79	0.014

S = 324.1 R-Sq = 35.8% R-Sq(adj) = 31.2%

Analysis of Variance

Source	DF	SS	MS	F	P
Regression	1	818539	818539	7.79	0.014
Residual Error	14	1470196	105014		
Total	15	2288735			

Unusual Observations

Obs	FY2	SO/ship	Fit	SE Fit	Residual	St Resid
14	1.00	2215.5	1526.4	147.9	689.1	2.39R

R denotes an observation with a large standardized residual

Regression Analysis: SO/ship versus FY2 (AOE 1 - LANT) MAPE = 11.9%

The regression equation is
SO/ship = 1424 + 80.0 FY2

Predictor	Coef	SE Coef	T	P
Constant	1423.8	106.3	13.39	0.000
FY2	80.01	31.35	2.55	0.023

S = 287.4 R-Sq = 31.7% R-Sq(adj) = 26.9%

Analysis of Variance

Source	DF	SS	MS	F	P
Regression	1	537720	537720	6.51	0.023
Residual Error	14	1155995	82571		
Total	15	1693715			

Unusual Observations

Obs	FY2	SO/ship	Fit	SE Fit	Residual	St Resid
14	1.00	2215.5	1503.8	131.2	711.7	2.78R

R denotes an observation with a large standardized residual

AOE 6 Class

Regression Analysis: SO/ship versus FY 2 (AOE 6 – PAC) MAPE = 39.8%

The regression equation is
 $SO/ship = 1445 + 174 \text{ FY } 2$

Predictor	Coef	SE Coef	T	P
Constant	1445.3	235.2	6.15	0.002
FY 2	173.86	83.14	2.09	0.091

S = 439.9 R-Sq = 46.7% R-Sq(adj) = 36.0%

Analysis of Variance

Source	DF	SS	MS	F	P
Regression	1	846337	846337	4.37	0.091
Residual Error	5	967701	193540		
Total	6	1814038			

Regression Analysis: SR/ship versus FY 2, Fleet 0=lant (AOE 6 Combined) MAPE=26.0%

The regression equation is
 $SR/ship = 1645 + 75.3 \text{ FY } 2 - 614 \text{ Fleet } 0=lant$

Predictor	Coef	SE Coef	T	P
Constant	1645.4	123.8	13.29	0.000
FY 2	75.27	31.98	2.35	0.036
Fleet 0=	-614.0	139.4	-4.41	0.001

S = 267.5 R-Sq = 65.6% R-Sq(adj) = 59.9%

Analysis of Variance

Source	DF	SS	MS	F	P
Regression	2	1636926	818463	11.44	0.002
Residual Error	12	858835	71570		
Total	14	2495761			

Source	DF	Seq SS
FY 2	1	247864
Fleet 0=	1	1389062

Unusual Observations

Obs	FY 2	SR/ship	Fit	SE Fit	Residual	St Resid
11	-1.00	308.0	956.1	106.1	-648.1	-2.64R

R denotes an observation with a large standardized residual

Regression Analysis: SR/ship versus FY 2 (AOE 6 – LANT) MAPE=12.6%

The regression equation is
SR/ship = 1667 + 92.3 FY 2

Predictor	Coef	SE Coef	T	P
Constant	1667.0	114.1	14.60	0.000
FY 2	92.30	33.66	2.74	0.034

S = 218.1 R-Sq = 55.6% R-Sq(adj) = 48.2%

Analysis of Variance

Source	DF	SS	MS	F	P
Regression	1	357849	357849	7.52	0.034
Residual Error	6	285514	47586		
Total	7	643363			

Unusual Observations

Obs	FY 2	SR/ship	Fit	SE Fit	Residual	St Resid
7	-6.00	750.0	1113.2	140.8	-363.2	-2.18R

R denotes an observation with a large standardized residual

ARS 50 Class

Regression Analysis: SO/ship versus FY 2 (ARS 50 – PAC) MAPE = 16.4%

The regression equation is
SO/ship = 709 + 48.1 FY 2

Predictor	Coef	SE Coef	T	P
Constant	708.97	55.77	12.71	0.000
FY 2	48.15	16.44	2.93	0.026

S = 106.6 R-Sq = 58.8% R-Sq(adj) = 52.0%

Analysis of Variance

Source	DF	SS	MS	F	P
Regression	1	97364	97364	8.57	0.026
Residual Error	6	68148	11358		
Total	7	165512			

Regression Analysis: SO/ship versus FY2 (ARS 50 – LANT) MAPE = 7.0%

The regression equation is
SO/ship = 470 + 45.3 FY2

Predictor	Coef	SE Coef	T	P
Constant	469.82	17.67	26.59	0.000
FY2	45.265	5.210	8.69	0.000

S = 33.77 R-Sq = 92.6% R-Sq(adj) = 91.4%

Analysis of Variance

Source	DF	SS	MS	F	P
Regression	1	86054	86054	75.47	0.000
Residual Error	6	6841	1140		
Total	7	92895			

Regression Analysis: SO/ship versus FY2 (ARS 50 – Combined) MAPE = 28.6%

The regression equation is
 SO/ship = 589 + 46.7 FY2

Predictor	Coef	SE Coef	T	P
Constant	589.38	53.28	11.06	0.000
FY2	46.70	15.71	2.97	0.010

S = 144.0 R-Sq = 38.7% R-Sq(adj) = 34.3%

Analysis of Variance

Source	DF	SS	MS	F	P
Regression	1	183162	183162	8.83	0.010
Residual Error	14	290304	20736		
Total	15	473466			

Regression Analysis: SO/ship versus FLT 0=LANT, FY2 (ARS 50 – Combined) MAPE = 11.8%

The regression equation is
 SO/ship = 473 + 232 FLT 0=LANT + 46.7 FY2

Predictor	Coef	SE Coef	T	P
Constant	473.43	33.96	13.94	0.000
FLT 0=LA	231.91	38.02	6.10	0.000
FY2	46.696	8.297	5.63	0.000

S = 76.04 R-Sq = 84.1% R-Sq(adj) = 81.7%

Analysis of Variance

Source	DF	SS	MS	F	P
Regression	2	398296	199148	34.44	0.000
Residual Error	13	75170	5782		
Total	15	473466			

Source	DF	Seq SS
FLT 0=LA	1	215134
FY2	1	183162

Unusual Observations

Obs	FLT 0=LA	SO/ship	Fit	SE Fit	Residual	St Resid
7	1.00	268.8	425.2	39.6	-156.4	-2.41R

R denotes an observation with a large standardized residual

Regression Analysis: SR/ship versus FY 2, FLT 0=LANT (ARS 50 – Combined) MAPE = 29.6%

The regression equation is
 SR/ship = 408 + 49.9 FY 2 + 259 FLT 0=LANT

Predictor	Coef	SE Coef	T	P
Constant	408.37	58.55	6.98	0.000
FY 2	49.95	14.31	3.49	0.004
FLT 0=LA	259.37	65.56	3.96	0.002

S = 131.1 R-Sq = 68.2% R-Sq(adj) = 63.3%

Analysis of Variance

Source	DF	SS	MS	F	P
Regression	2	478652	239326	13.92	0.001
Residual Error	13	223469	17190		
Total	15	702120			

Source	DF	Seq SS
FY 2	1	209550
FLT 0=LA	1	269102

Unusual Observations

Obs	FY 2	SR/ship	Fit	SE Fit	Residual	St Resid
6	1.00	198.0	458.3	68.2	-260.3	-2.33R

R denotes an observation with a large standardized residual

Regression Analysis: SR/ship versus FY 2 (ARS 50 – Combined) MAPE = 37.4%

The regression equation is
 $SR/ship = 538 + 49.9 \text{ FY 2}$

Predictor	Coef	SE Coef	T	P
Constant	538.05	69.40	7.75	0.000
FY 2	49.95	20.47	2.44	0.029

S = 187.6 R-Sq = 29.8% R-Sq(adj) = 24.8%

Analysis of Variance

Source	DF	SS	MS	F	P
Regression	1	209550	209550	5.96	0.029
Residual Error	14	492570	35184		
Total	15	702120			

Unusual Observations

Obs	FY 2	SR/ship	Fit	SE Fit	Residual	St Resid
6	1.00	198.0	588.0	85.6	-390.0	-2.34R

R denotes an observation with a large standardized residual

Regression Analysis: SR/ship versus FY 2, FLT 0=LANT, Total UW / SY (ARS 50 – Combined) MAPE = 25.6%

The regression equation is
 $SR/ship = -78 + 66.8 \text{ FY 2} + 281 \text{ FLT 0=LANT} + 5.66 \text{ Total UW / SY}$

Predictor	Coef	SE Coef	T	P
Constant	-78.5	264.2	-0.30	0.772
FY 2	66.76	16.00	4.17	0.002
FLT 0=LA	281.48	67.81	4.15	0.002
Total UW	5.659	3.079	1.84	0.096

S = 120.9 R-Sq = 76.0% R-Sq(adj) = 68.8%

Analysis of Variance

Source	DF	SS	MS	F	P
Regression	3	463733	154578	10.57	0.002
Residual Error	10	146239	14624		
Total	13	609972			

Source	DF	Seq SS
FY 2	1	125299
FLT 0=LA	1	289041
Total UW	1	49394

Unusual Observations

Obs	FY 2	SR/ship	Fit	SE Fit	Residual	St Resid
6	1.00	198.0	409.8	68.1	-211.8	-2.12R

R denotes an observation with a large standardized residual

Regression Analysis: SR/ship versus FY 2 (ARS 50 – PAC) MAPE = 19.5%

The regression equation is
 $SR/ship = 751 + 80.0 \text{ FY 2}$

Predictor	Coef	SE Coef	T	P
Constant	750.95	60.29	12.46	0.000
FY 2	79.97	17.78	4.50	0.004

S = 115.2 R-Sq = 77.1% R-Sq(adj) = 73.3%

Analysis of Variance

Source	DF	SS	MS	F	P
Regression	1	268612	268612	20.23	0.004
Residual Error	6	79648	13275		
Total	7	348260			

CG 47 Class

Regression Analysis: SO/ship versus FY2 (CG 47 – LANT) MAPE = 6.4%

The regression equation is
 $SO/ship = 869 + 36.7 \text{ FY2}$

Predictor	Coef	SE Coef	T	P
Constant	868.79	36.47	23.82	0.000
FY2	36.68	10.75	3.41	0.014

S = 69.69 R-Sq = 66.0% R-Sq(adj) = 60.3%

Analysis of Variance

Source	DF	SS	MS	F	P
Regression	1	56501	56501	11.63	0.014
Residual Error	6	29140	4857		
Total	7	85641			

Regression Analysis: SR/ship versus FY 2 (CG 47 – Combined) MAPE = 15.9%

The regression equation is
SR/ship = 2535 + 101 FY 2

Predictor	Coef	SE Coef	T	P
Constant	2535.2	139.2	18.21	0.000
FY 2	100.95	41.05	2.46	0.028

S = 376.2 R-Sq = 30.2% R-Sq(adj) = 25.2%

Analysis of Variance

Source	DF	SS	MS	F	P
Regression	1	856104	856104	6.05	0.028
Residual Error	14	1981362	141526		
Total	15	2837465			

Unusual Observations

Obs	FY 2	SR/ship	Fit	SE Fit	Residual	St Resid
1	-6.00	888.9	1929.4	171.7	-1040.6	-3.11R

R denotes an observation with a large standardized residual

Regression Analysis: SR/ship versus FY2 (CG 47 – PAC) MAPE = 16.7%

The regression equation is
SR/ship = 2589 + 179 FY2

Predictor	Coef	SE Coef	T	P
Constant	2588.6	209.4	12.36	0.000
FY2	178.66	61.75	2.89	0.028

S = 400.2 R-Sq = 58.2% R-Sq(adj) = 51.3%

Analysis of Variance

Source	DF	SS	MS	F	P
Regression	1	1340636	1340636	8.37	0.028
Residual Error	6	960996	160166		
Total	7	2301631			

Unusual Observations

Obs	FY2	SR/ship	Fit	SE Fit	Residual	St Resid
1	-6.00	889	1517	258	-628	-2.05R

R denotes an observation with a large standardized residual

DD 963 Class

Regression Analysis: SR/ship versus FY 2 (DD 963 – PAC) MAPE = 17.8%

The regression equation is
SR/ship = 999 + 66.5 FY 2

Predictor	Coef	SE Coef	T	P
Constant	998.52	96.56	10.34	0.000
FY 2	66.45	28.47	2.33	0.058

S = 184.5 R-Sq = 47.6% R-Sq(adj) = 38.8%

Analysis of Variance

Source	DF	SS	MS	F	P
Regression	1	185459	185459	5.45	0.058
Residual Error	6	204319	34053		
Total	7	389778			

Regression Analysis: SO/ship versus FY2 (DD 963 – LANT) MAPE = 6.0%

The regression equation is
SO/ship = 754 + 18.2 FY2

Predictor	Coef	SE Coef	T	P
Constant	754.38	32.23	23.41	0.000
FY2	18.241	9.503	1.92	0.103

S = 61.59 R-Sq = 38.0% R-Sq(adj) = 27.7%

Analysis of Variance

Source	DF	SS	MS	F	P
Regression	1	13975	13975	3.68	0.103
Residual Error	6	22759	3793		
Total	7	36734			

Regression Analysis: SO/ship versus FY2 (DD 963 – Combined) MAPE = 14.4%

The regression equation is
SO/ship = 876 + 42.3 FY2

Predictor	Coef	SE Coef	T	P
Constant	876.43	57.42	15.26	0.000
FY2	42.34	16.93	2.50	0.025

S = 155.2 R-Sq = 30.9% R-Sq(adj) = 25.9%

Analysis of Variance

Source	DF	SS	MS	F	P
Regression	1	150614	150614	6.25	0.025
Residual Error	14	337107	24079		
Total	15	487720			

Unusual Observations

Obs	FY2	SO/ship	Fit	SE Fit	Residual	St Resid
8	1.00	1260.9	918.8	70.8	342.1	2.48R

R denotes an observation with a large standardized residual

Regression Analysis: Sr/ship versus FY2 (DD 963 – Combined) MAPE = 12.7%

The regression equation is

$$\text{Sr/ship} = 2025 + 123 \text{ FY2}$$

Predictor	Coef	SE Coef	T	P
Constant	2025.46	88.38	22.92	0.000
FY2	123.30	26.06	4.73	0.000

S = 238.9 R-Sq = 61.5% R-Sq(adj) = 58.8%

Analysis of Variance

Source	DF	SS	MS	F	P
Regression	1	1277123	1277123	22.38	0.000
Residual Error	14	798818	57058		
Total	15	2075941			

Unusual Observations

Obs	FY2	Sr/ship	Fit	SE Fit	Residual	St Resid
1	-6.00	746.8	1285.6	109.0	-538.8	-2.54R

R denotes an observation with a large standardized residual

Regression Analysis: SR/ship versus FY 2 (DD 963 – LANT) MAPE = 4.4%

The regression equation is

$$\text{SR/ship} = 1958 + 65.3 \text{ FY 2}$$

Predictor	Coef	SE Coef	T	P
Constant	1958.27	55.92	35.02	0.000
FY 2	65.34	16.49	3.96	0.007

S = 106.9 R-Sq = 72.4% R-Sq(adj) = 67.7%

Analysis of Variance

Source	DF	SS	MS	F	P
Regression	1	179327	179327	15.70	0.007
Residual Error	6	68521	11420		
Total	7	247848			

Unusual Observations

Obs	FY 2	SR/ship	Fit	SE Fit	Residual	St Resid
6	1.00	2193.2	2023.6	69.0	169.5	2.08R

R denotes an observation with a large standardized residual

Regression Analysis: SR/ship versus FY 2 (DD 963 – PAC) MAPE = 9.1%

The regression equation is
SR/ship = 2034 + 122 FY 2

Predictor	Coef	SE Coef	T	P
Constant	2033.6	112.7	18.04	0.000
FY 2	122.16	33.25	3.67	0.010

S = 215.5 R-Sq = 69.2% R-Sq(adj) = 64.1%

Analysis of Variance

Source	DF	SS	MS	F	P
Regression	1	626819	626819	13.50	0.010
Residual Error	6	278555	46426		
Total	7	905373			

DDG 51 Class

Regression Analysis: SO/ship versus FY2 (DDG 51 – LANT) MAPE = 6.7%

The regression equation is
SO/ship = 711 + 18.7 FY2

Predictor	Coef	SE Coef	T	P
Constant	711.39	30.73	23.15	0.000
FY2	18.741	9.061	2.07	0.084

S = 58.72 R-Sq = 41.6% R-Sq(adj) = 31.9%

Analysis of Variance

Source	DF	SS	MS	F	P
Regression	1	14752	14752	4.28	0.084
Residual Error	6	20687	3448		
Total	7	35439			

Regression Analysis: SR versus FY2, U/W non-dep, U/W dep (DDG 51 – Combined) MAPE = 10.4%

-This is a prediction for SR cost for the entire class not per ship

The regression equation is

SR = 10233 + 1322 FY2 + 7.14 U/W non-dep + 4.86 U/W dep

Predictor	Coef	SE Coef	T	P
Constant	10233	3230	3.17	0.010
FY2	1322.1	445.6	2.97	0.014
U/W non-	7.138	1.868	3.82	0.003
U/W dep	4.857	2.250	2.16	0.056

S = 1070 R-Sq = 97.7% R-Sq(adj) = 97.0%

Analysis of Variance

Source	DF	SS	MS	F	P
Regression	3	484611148	161537049	141.00	0.000
Residual Error	10	11456758	1145676		
Total	13	496067906			

Source	DF	Seq SS
FY2	1	467830737
U/W non-	1	11444039
U/W dep	1	5336372

Unusual Observations

Obs	FY2	SR	Fit	SE Fit	Residual	St Resid
7	-6.00	2086	3856	677	-1770	-2.13R

R denotes an observation with a large standardized residual

Regression Analysis: SR/ship versus FY2 (DDG 51 – LANT) MAPE = 8.9%

The regression equation is
 SR/ship = 1328 - 98.0 FY2

Predictor	Coef	SE Coef	T	P
Constant	1328.16	98.27	13.51	0.000
FY2	-98.01	28.98	-3.38	0.015

S = 187.8 R-Sq = 65.6% R-Sq(adj) = 59.9%

Analysis of Variance

Source	DF	SS	MS	F	P
Regression	1	403429	403429	11.44	0.015
Residual Error	6	211628	35271		
Total	7	615058			

FFG 7 Class

Regression Analysis: SR/ship versus FY 2 (FFG 7 – PAC) MAPE = 12.9%

The regression equation is
 SR/ship = 791 + 49.5 FY 2

Predictor	Coef	SE Coef	T	P
Constant	791.12	65.10	12.15	0.000
FY 2	49.47	19.20	2.58	0.042

S = 124.4 R-Sq = 52.5% R-Sq(adj) = 44.6%

Analysis of Variance

Source	DF	SS	MS	F	P
Regression	1	102802	102802	6.64	0.042
Residual Error	6	92862	15477		
Total	7	195664			

Regression Analysis: SO/ship versus FY2 (FFG 7 – LANT) MAPE = 3.7%

The regression equation is
 $SO/ship = 617 + 24.2 \text{ FY2}$

Predictor	Coef	SE Coef	T	P
Constant	617.03	15.55	39.69	0.000
FY2	24.245	4.584	5.29	0.002

S = 29.71 R-Sq = 82.3% R-Sq(adj) = 79.4%

Analysis of Variance

Source	DF	SS	MS	F	P
Regression	1	24689	24689	27.97	0.002
Residual Error	6	5295	883		
Total	7	29984			

Regression Analysis: SO/ship versus FLT 0=LANT, FY2 (FFG 7 – Combined) MAPE = 9.9%

The regression equation is
 $SO/ship = 649 + 111 \text{ FLT 0=LANT} + 36.9 \text{ FY2}$

Predictor	Coef	SE Coef	T	P
Constant	648.59	41.36	15.68	0.000
FLT 0=LA	111.00	46.31	2.40	0.032
FY2	36.86	10.11	3.65	0.003

S = 92.61 R-Sq = 59.4% R-Sq(adj) = 53.2%

Analysis of Variance

Source	DF	SS	MS	F	P
Regression	2	163417	81708	9.53	0.003
Residual Error	13	111506	8577		
Total	15	274922			

Source	DF	Seq SS
FLT 0=LA	1	49284
FY2	1	114133

Unusual Observations

Obs	FLT 0=LA	SO/ship	Fit	SE Fit	Residual	St Resid
14	1.00	1000.5	796.4	48.2	204.0	2.58R

R denotes an observation with a large standardized residual

Regression Analysis: SO/ship versus FY2 (FFG 7- Combined) MAPE = 10.6%

The regression equation is
 $SO/ship = 704 + 36.9 \text{ FY2}$

Predictor	Coef	SE Coef	T	P
Constant	704.09	39.65	17.76	0.000
FY2	36.86	11.69	3.15	0.007

S = 107.2 R-Sq = 41.5% R-Sq(adj) = 37.3%

Analysis of Variance

Source	DF	SS	MS	F	P
Regression	1	114133	114133	9.94	0.007
Residual Error	14	160790	11485		
Total	15	274922			

Unusual Observations

Obs	FY2	SO/ship	Fit	SE Fit	Residual	St Resid
14	1.00	1000.5	740.9	48.9	259.5	2.72R

R denotes an observation with a large standardized residual

Regression Analysis: SR/Ship versus FY2, FLT 0=LANT (FFG 7 – Combined)
MAPE = 9.4%

The regression equation is

$$\text{SR/Ship} = 1532 + 75.6 \text{ FY2} - 231 \text{ FLT 0=LANT}$$

Predictor	Coef	SE Coef	T	P
Constant	1532.36	58.59	26.15	0.000
FY2	75.64	14.32	5.28	0.000
FLT 0=LA	-231.25	65.60	-3.53	0.004

S = 131.2 R-Sq = 75.6% R-Sq(adj) = 71.9%

Analysis of Variance

Source	DF	SS	MS	F	P
Regression	2	694541	347270	20.17	0.000
Residual Error	13	223783	17214		
Total	15	918324			

Source	DF	Seq SS
FY2	1	480635
FLT 0=LA	1	213906

Unusual Observations

Obs	FY2	SR/Ship	Fit	SE Fit	Residual	St Resid
7	-6.00	487.0	847.2	68.3	-360.2	-3.22R

R denotes an observation with a large standardized residual

Regression Analysis: SR/Ship versus FY2 (FFG 7 – Combined) MAPE = 13.3%

The regression equation is

$$\text{SR/Ship} = 1417 + 75.6 \text{ FY2}$$

Predictor	Coef	SE Coef	T	P
Constant	1416.73	65.42	21.66	0.000
FY2	75.64	19.29	3.92	0.002

S = 176.8 R-Sq = 52.3% R-Sq(adj) = 48.9%

Analysis of Variance

Source	DF	SS	MS	F	P
Regression	1	480635	480635	15.37	0.002
Residual Error	14	437689	31264		
Total	15	918324			

Unusual Observations

Obs	FY2	SR/Ship	Fit	SE Fit	Residual	St Resid
7	-6.00	487.0	962.9	80.7	-475.9	-3.02R

R denotes an observation with a large standardized residual

Regression Analysis: SR/ship versus FY2 (FFG 7 – LANT) MAPE = 3.0%

The regression equation is
 SR/ship = 1451 + 43.1 FY2

Predictor	Coef	SE Coef	T	P
Constant	1450.98	30.99	46.83	0.000
FY2	43.072	9.137	4.71	0.003

S = 59.22 R-Sq = 78.7% R-Sq(adj) = 75.2%

Analysis of Variance

Source	DF	SS	MS	F	P
Regression	1	77919	77919	22.22	0.003
Residual Error	6	21040	3507		
Total	7	98960			

Unusual Observations

Obs	FY2	SR/ship	Fit	SE Fit	Residual	St Resid
6	1.00	1600.4	1494.0	38.2	106.4	2.35R

R denotes an observation with a large standardized residual

Regression Analysis: SR/ship versus FY2 (FFG 7 – PAC) MAPE = 4.9%

The regression equation is
 SR/ship = 1328 + 53.5 FY2

Predictor	Coef	SE Coef	T	P
Constant	1328.09	44.04	30.16	0.000
FY2	53.50	12.99	4.12	0.006

S = 84.16 R-Sq = 73.9% R-Sq(adj) = 69.5%

Analysis of Variance

Source	DF	SS	MS	F	P
Regression	1	120214	120214	16.97	0.006
Residual Error	6	42495	7082		
Total	7	162709			

Unusual Observations

Obs	FY2	SR/ship	Fit	SE Fit	Residual	St Resid
1	-6.00	1145.7	1007.1	54.3	138.6	2.16R

R denotes an observation with a large standardized residual

LHA 1 Class

Regression Analysis: SO/ship versus FY2 (LHA 1 – Combined) MAPE = 12.2%

The regression equation is
 $SO/ship = 2687 + 167 FY2$

Predictor	Coef	SE Coef	T	P
Constant	2687.0	130.1	20.66	0.000
FY2	167.34	38.36	4.36	0.001

S = 351.6 R-Sq = 57.6% R-Sq(adj) = 54.6%

Analysis of Variance

Source	DF	SS	MS	F	P
Regression	1	2352205	2352205	19.03	0.001
Residual Error	14	1730365	123597		
Total	15	4082569			

Regression Analysis: SO/ship versus FY2, TOT/sy (LHA 1 – Combined) MAPE = 12.0%

The regression equation is
 $SO/ship = 1530 + 156 FY2 + 10.3 TOT/sy$

Predictor	Coef	SE Coef	T	P
Constant	1529.9	640.3	2.39	0.036
FY2	155.70	43.66	3.57	0.004
TOT/sy	10.340	5.633	1.84	0.094

S = 345.6 R-Sq = 60.8% R-Sq(adj) = 53.6%

Analysis of Variance

Source	DF	SS	MS	F	P
Regression	2	2033614	1016807	8.51	0.006
Residual Error	11	1313651	119423		
Total	13	3347265			

Source	DF	Seq SS
FY2	1	1631195
TOT/sy	1	402420

Regression Analysis: SO/ship versus FY 2, tot/sy (LHA 1 – PAC) MAPE = 10.5%

The regression equation is
 SO/ship = 1442 + 184 FY 2 + 12.8 tot/sy

Predictor	Coef	SE Coef	T	P
Constant	1442.2	751.7	1.92	0.113
FY 2	184.48	48.83	3.78	0.013
tot/sy	12.844	6.404	2.01	0.101

S = 298.9 R-Sq = 83.9% R-Sq(adj) = 77.5%

Analysis of Variance

Source	DF	SS	MS	F	P
Regression	2	2330628	1165314	13.04	0.010
Residual Error	5	446761	89352		
Total	7	2777388			

Source	DF	Seq SS
FY 2	1	1971228
tot/sy	1	3593

Regression Analysis: SO/ship versus FY 2 (LHA 1 – PAC) MAPE = 13.6%

The regression equation is
 SO/ship = 2917 + 217 FY 2

Predictor	Coef	SE Coef	T	P
Constant	2916.8	191.8	15.21	0.000
FY 2	216.64	56.56	3.83	0.009

S = 366.6 R-Sq = 71.0% R-Sq(adj) = 66.1%

Analysis of Variance

Source	DF	SS	MS	F	P
Regression	1	1971228	1971228	14.67	0.009
Residual Error	6	806160	134360		
Total	7	2777388			

Regression Analysis: SO/ship versus FY2 (LHA 1 – LANT) MAPE = 7.1%

The regression equation is
 SO/ship = 2457 + 118 FY2

Predictor	Coef	SE Coef	T	P
Constant	2457.3	156.7	15.68	0.000
FY2	118.07	46.22	2.55	0.043

S = 299.6 R-Sq = 52.1% R-Sq(adj) = 44.1%

Analysis of Variance

Source	DF	SS	MS	F	P
Regression	1	585516	585516	6.52	0.043
Residual Error	6	538410	89735		
Total	7	1123926			

Unusual Observations

Obs	FY2	SO/ship	Fit	SE Fit	Residual	St Resid
3	-2.00	2876	2221	108	654	2.34R

R denotes an observation with a large standardized residual

Regression Analysis: SR/Ship versus FY2 (LHA 1 – Combined) MAPE = 15.2%

The regression equation is
 SR/Ship = 2148 + 91.3 FY2

Predictor	Coef	SE Coef	T	P
Constant	2148.3	127.2	16.89	0.000
FY2	91.33	37.50	2.44	0.029

S = 343.7 R-Sq = 29.8% R-Sq(adj) = 24.7%

Analysis of Variance

Source	DF	SS	MS	F	P
Regression	1	700727	700727	5.93	0.029
Residual Error	14	1653433	118102		
Total	15	2354160			

Regression Analysis: SR/ship versus FY2 (LHA 1 – PAC) MAPE = 14.4%

The regression equation is
 SR/ship = 2350 + 176 FY2

Predictor	Coef	SE Coef	T	P
Constant	2349.5	174.6	13.46	0.000
FY2	176.30	51.48	3.42	0.014

S = 333.6 R-Sq = 66.2% R-Sq(adj) = 60.5%

Analysis of Variance

Source	DF	SS	MS	F	P
Regression	1	1305463	1305463	11.73	0.014
Residual Error	6	667811	111302		
Total	7	1973275			

LHD 1 Class

Regression Analysis: SO/ship versus FY2, FLT 0=LANT (LHD 1 – Combined) MAPE = 14.7%

The regression equation is
 SO/ship = 2399 + 173 FY2 + 447 FLT 0=LANT

Predictor	Coef	SE Coef	T	P
Constant	2399.3	195.3	12.29	0.000
FY2	172.72	47.72	3.62	0.003
FLT 0=LA	447.2	218.7	2.04	0.062

S = 437.4 R-Sq = 57.1% R-Sq(adj) = 50.5%

Analysis of Variance

Source	DF	SS	MS	F	P
Regression	2	3305755	1652878	8.64	0.004
Residual Error	13	2486642	191280		
Total	15	5792398			

Source	DF	Seq SS
FY2	1	2505964
FLT 0=LA	1	799791

Unusual Observations

Obs	FY2	SO/ship	Fit	SE Fit	Residual	St Resid
5	-2.00	3455	2501	156	954	2.34R

R denotes an observation with a large standardized residual

Regression Analysis: SO/ship versus FY2 (LHD 1 – Combined) MAPE = 15.6%

The regression equation is
 $SO/ship = 2623 + 173 FY2$

Predictor	Coef	SE Coef	T	P
Constant	2622.9	179.3	14.63	0.000
FY2	172.72	52.86	3.27	0.006

S = 484.5 R-Sq = 43.3% R-Sq(adj) = 39.2%

Analysis of Variance

Source	DF	SS	MS	F	P
Regression	1	2505964	2505964	10.68	0.006
Residual Error	14	3286434	234745		
Total	15	5792398			

Unusual Observations

Obs	FY2	SO/ship	Fit	SE Fit	Residual	St Resid
5	-2.00	3455	2277	124	1178	2.51R

R denotes an observation with a large standardized residual

Regression Analysis: SO/ship versus FY 2 (LHD 1 – PAC) MAPE = 16.9%

The regression equation is
 $SO/ship = 2965 + 220 FY 2$

Predictor	Coef	SE Coef	T	P
Constant	2964.7	289.5	10.24	0.000
FY 2	220.01	85.38	2.58	0.042

S = 553.3 R-Sq = 52.5% R-Sq(adj) = 44.6%

Analysis of Variance

Source	DF	SS	MS	F	P
Regression	1	2033020	2033020	6.64	0.042
Residual Error	6	1836946	306158		
Total	7	3869966			

Regression Analysis: SO/ship versus FY2 (LHD 1 – LANT) MAPE = 9.4%

The regression equation is
SO/ship = 2281 + 125 FY2

Predictor	Coef	SE Coef	T	P
Constant	2281.1	145.1	15.72	0.000
FY2	125.42	42.80	2.93	0.026

S = 277.4 R-Sq = 58.9% R-Sq(adj) = 52.0%

Analysis of Variance

Source	DF	SS	MS	F	P
Regression	1	660648	660648	8.59	0.026
Residual Error	6	461662	76944		
Total	7	1122309			

Unusual Observations

Obs	FY2	SO/ship	Fit	SE Fit	Residual	St Resid
3	-2.00	1441.0	2030.2	100.4	-589.2	-2.28R

R denotes an observation with a large standardized residual

LPD 4 Class

Regression Analysis: SO/ship versus FY2, FLT 0=LANT (LPD 4 – Combined)

MAPE= 28.8%

The regression equation is

$$\text{SO/ship} = 983 + 48.7 \text{ FY2} + 269 \text{ FLT 0=LANT}$$

Predictor	Coef	SE Coef	T	P
Constant	983.0	102.1	9.62	0.000
FY2	48.72	24.96	1.95	0.073
FLT 0=LA	269.0	114.4	2.35	0.035

S = 228.8 R-Sq = 41.8% R-Sq(adj) = 32.9%

Analysis of Variance

Source	DF	SS	MS	F	P
Regression	2	488932	244466	4.67	0.030
Residual Error	13	680260	52328		
Total	15	1169192			

Source	DF	Seq SS
FY2	1	199389
FLT 0=LA	1	289543

Unusual Observations

Obs	FY2	SO/ship	Fit	SE Fit	Residual	St Resid
11	-2.00	213.0	885.6	81.8	-672.6	-3.15R

R denotes an observation with a large standardized residual

Regression Analysis: SO/ship versus FY 2 (LPD 4 – PAC) MAPE = 7.3%

The regression equation is

$$\text{SO/ship} = 1333 + 81.2 \text{ FY 2}$$

Predictor	Coef	SE Coef	T	P
Constant	1333.15	58.23	22.89	0.000
FY 2	81.15	17.17	4.73	0.003

S = 111.3 R-Sq = 78.8% R-Sq(adj) = 75.3%

Analysis of Variance

Source	DF	SS	MS	F	P
Regression	1	276602	276602	22.34	0.003
Residual Error	6	74300	12383		
Total	7	350902			

LSD 36 Class

Regression Analysis: SO/ship versus FY 2 (LSD 36 – PAC) MAPE = 13.8%

The regression equation is
SO/ship = 1125 + 85.9 FY 2

Predictor	Coef	SE Coef	T	P
Constant	1124.71	83.45	13.48	0.000
FY 2	85.91	24.61	3.49	0.013

S = 159.5 R-Sq = 67.0% R-Sq(adj) = 61.5%

Analysis of Variance

Source	DF	SS	MS	F	P
Regression	1	309987	309987	12.19	0.013
Residual Error	6	152589	25431		
Total	7	462576			

APPENDIX E: SUMMARY OF INDIVIDUAL SHIP REGRESSIONS BY CLASS

This Appendix considers regressions that are structured to produce an equation to calculate SR cost on an individual ship. These regressions are grouped by class of ship. Following the regression equation a Mean Absolute Percentage Error is provided when this model is used to backcast costs. Regressions were performed for all the ships of a class. Further regressions were performed once the ships were grouped by the fleet to which they are assigned and then by class. This was done to see if any other relationships might be discovered that were fleet specific.

To summarize, the variables used in the following regressions and their meanings are as follows:

Dependent Variables	
SR	A dependent variable to estimate repair parts costs when using “by hull” data.
SO	A dependent variable to estimate SO consumable costs when using “by hull” data.
Independent Variables	
FY	An independent variable representing the current fiscal year. Fiscal Year 2000 was used as the base (00). Therefore fiscal year 1999 is represented by a negative one (-1) and fiscal year 2001 by a positive one (1).
Pac Flt	A binary (one or zero) indicator variable to represent the fleet in which a ship is home ported. A ship assigned to the Atlantic Fleet would have a value of zero and one assigned to the Pacific Fleet would have a value of one.
UW not dep	Represents the days spent underway and while not in a deployed status. In the NUERS database this is represented by the time spent in code eight.
Code 17	Represents the days underway on deployment while in the 5 th Fleet AOR. This time is represented by code 17 in the NUERS database.
UW dep not 17	Represents the days spent underway and on deployment when operating in areas SO than the 5 th fleet AOR. This is represented by the code nine in the NUERS database.
Total UW de- ployed	Is the summation of the days under “Code 17” and “Total UW deployed.” This represents the total number of days underway while in a deployed status.
Total UW	Represents the total number of days a ship was underway in a year. It is the summation of the time spent in codes eight, nine and seventeen in the NUERS database.

Table 23: List of Variables Used in Regressions in Appendix E

AOE-1 Class

SO:

There were no significant regressions for SO as a dependent variable. No regressions met the 90% significance threshold. This was true for all AOE-1 class ships combined as well as separated by fleet.

SR:

Combined:

Regression Analysis: EMRM versus two digit year, Pac Flt, Total_1

The regression equation is

$$\text{EMRM} = 1179276 + 194205 \text{ two digit year} - 447725 \text{ Pac Flt} + 2952 \text{ Total}_1$$

MAPE 27.9%

Predictor	Coef	SE Coef	T	P
Constant	1179276	262025	4.50	0.000
two digi	194205	56987	3.41	0.004
Pac Flt	-447725	148635	-3.01	0.009
Total_1	2952	1782	1.66	0.120

S = 307701 R-Sq = 61.3% R-Sq(adj) = 53.0%

Analysis of Variance

Source	DF	SS	MS	F	P
Regression	3	2.10240E+12	7.00800E+11	7.40	0.003
Residual Error	14	1.32552E+12	94680153575		
Total	17	3.42792E+12			

Source	DF	Seq SS
two digi	1	9.87195E+11
Pac Flt	1	8.55520E+11
Total_1	1	2.59684E+11

Regression Analysis: EMRM versus two digit year, Pac Flt

The regression equation is

$$\text{EMRM} = 1582192 + 210046 \text{ two digit year} - 446790 \text{ Pac Flt}$$

MAPE 19.6%

Predictor	Coef	SE Coef	T	P
Constant	1582192	102801	15.39	0.000
two digi	210046	59352	3.54	0.003
Pac Flt	-446790	157031	-2.85	0.012

S = 325085 R-Sq = 53.8% R-Sq(adj) = 47.6%

Analysis of Variance

Source	DF	SS	MS	F	P
Regression	2	1.84271E+12	9.21357E+11	8.72	0.003
Residual Error	15	1.58521E+12	1.05680E+11		
Total	17	3.42792E+12			

Source	DF	Seq SS
two digi	1	9.87195E+11
Pac Flt	1	8.55520E+11

Atlantic Fleet

Regression Analysis: EMRM versus two-digit year, Total_1

The regression equation is

$$\text{EMRM} = 1216456 + 168466 \text{ two digit year} + 2679 \text{ Total}_1$$

MAPE 9.8%

Predictor	Coef	SE Coef	T	P
Constant	1216456	198754	6.12	0.000
two digi	168466	49580	3.40	0.011
Total_1	2679	1363	1.97	0.090

S = 221304 R-Sq = 70.0% R-Sq(adj) = 61.4%

Analysis of Variance

Source	DF	SS	MS	F	P
Regression	2	7.98273E+11	3.99136E+11	8.15	0.015
Residual Error	7	3.42828E+11	48975435200		
Total	9	1.14110E+12			

Source	DF	Seq SS
two digi	1	6.08966E+11
Total_1	1	1.89307E+11

Regression Analysis: EMRM versus two digit year

The regression equation is

$$\text{EMRM} = 1582192 + 174494 \text{ two digit year}$$

MAPE 12.0%

Predictor	Coef	SE Coef	T	P
Constant	1582192	81558	19.40	0.000
two digi	174494	57670	3.03	0.016

S = 257909 R-Sq = 53.4% R-Sq(adj) = 47.5%

Analysis of Variance

Source	DF	SS	MS	F	P
Regression	1	6.08966E+11	6.08966E+11	9.16	0.016
Residual Error	8	5.32135E+11	66516868567		
Total	9	1.14110E+12			

Unusual Observations

Obs	two digi	EMRM	Fit	SE Fit	Residual	St Resid
1	2.00	2402636	1931181	141262	471455	2.18R

Pacific Fleet

Regression Analysis: EMRM versus two digit year

The regression equation is
EMRM = 1099850 + 281150 two digit year
MAPE 27.2%

Predictor	Coef	SE Coef	T	P
Constant	1099850	156304	7.04	0.000
two digi	281150	127622	2.20	0.070

S = 403575 R-Sq = 44.7% R-Sq(adj) = 35.5%

Analysis of Variance

Source	DF	SS	MS	F	P
Regression	1	7.90453E+11	7.90453E+11	4.85	0.070
Residual Error	6	9.77235E+11	1.62873E+11		
Total	7	1.76769E+12			

AOE-6 Class

SO:

Combined

Regression Analysis: OTHER versus Pac Flt, Total_1

The regression equation is
OTHER = 230024 + 585647 Pac Flt + 3912 Total_1
MAPE = 19.9%

Predictor	Coef	SE Coef	T	P
Constant	230024	185603	1.24	0.237
Pac Flt	585647	131199	4.46	0.001
Total_1	3912	1297	3.02	0.010

S = 256106 R-Sq = 72.9% R-Sq(adj) = 68.7%

Analysis of Variance

Source	DF	SS	MS	F	P
Regression	2	2.29535E+12	1.14768E+12	17.50	0.000
Residual Error	13	8.52674E+11	65590285747		
Total	15	3.14802E+12			

Source	DF	Seq SS
Pac Flt	1	1.69829E+12
Total_1	1	5.97065E+11

Regression Analysis: OTHER versus Pac Flt, UW not dep, Total UW deployed

The regression equation is
OTHER = - 7758 + 577636 Pac Flt + 7567 UW not dep + 3842 Total UW deployed
MAPE = 21.7%

Predictor	Coef	SE Coef	T	P
Constant	-7758	241872	-0.03	0.975
Pac Flt	577636	126043	4.58	0.001
UW not d	7567	2806	2.70	0.019
Total UW	3842	1245	3.08	0.009

S = 245807 R-Sq = 77.0% R-Sq(adj) = 71.2%

Analysis of Variance

Source	DF	SS	MS	F	P
Regression	3	2.42297E+12	8.07657E+11	13.37	0.000
Residual Error	12	7.25053E+11	60421051436		
Total	15	3.14802E+12			

Source	DF	Seq SS
Pac Flt	1	1.69829E+12
UW not d	1	1.49664E+11
Total UW	1	5.75023E+11

Atlantic Fleet:

Regression Analysis: OTHER versus 2 digit year, Total_1

The regression equation is

$$\text{OTHER} = 389230 - 95086 \text{ 2 digit year} + 2493 \text{ Total}_1$$

MAPE = 15.1%

Predictor	Coef	SE Coef	T	P
Constant	389230	155842	2.50	0.047
2 digit	-95086	42999	-2.21	0.069
Total_1	2493	1169	2.13	0.077

S = 162403 R-Sq = 68.8% R-Sq(adj) = 58.4%

Analysis of Variance

Source	DF	SS	MS	F	P
Regression	2	3.49558E+11	1.74779E+11	6.63	0.030
Residual Error	6	1.58248E+11	26374710426		
Total	8	5.07806E+11			

Source	DF	Seq SS
2 digit	1	2.29616E+11
Total_1	1	1.19941E+11

Unusual Observations

Obs	2 digit	OTHER	Fit	SE Fit	Residual	St Resid
4	1.00	238253	523506	78325	-285253	-2.01R

R denotes an observation with a large standardized residual

Regression Analysis: OTHER versus 2 digit year

The regression equation is

$$\text{OTHER} = 700259 - 121495 \text{ 2 digit year}$$

MAPE = 34.6%

Predictor	Coef	SE Coef	T	P
Constant	700259	67393	10.39	0.000
2 digit	-121495	50545	-2.40	0.047

S = 199352 R-Sq = 45.2% R-Sq(adj) = 37.4%

Analysis of Variance

Source	DF	SS	MS	F	P
Regression	1	2.29616E+11	2.29616E+11	5.78	0.047
Residual Error	7	2.78190E+11	39741390125		
Total	8	5.07806E+11			

Regression Analysis: OTHER versus Total_1

The regression equation is
 OTHER = 315716 + 3238 Total_1
 MAPE = 18.4%

Predictor	Coef	SE Coef	T	P
Constant	315716	189907	1.66	0.140
Total_1	3238	1396	2.32	0.054

S = 202564 R-Sq = 43.4% R-Sq(adj) = 35.4%

Analysis of Variance

Source	DF	SS	MS	F	P
Regression	1	2.20580E+11	2.20580E+11	5.38	0.054
Residual Error	7	2.87226E+11	41032300600		
Total	8	5.07806E+11			

Unusual Observations

Obs	Total_1	OTHER	Fit	SE Fit	Residual	St Resid
4	92	238253	613580	83445	-375327	-2.03R

R denotes an observation with a large standardized residual

SR:

Combined:

Regression Analysis: EMRM versus Pac Flt, UW not dep, Total UW deployed

The regression equation is
 EMRM = 461317 - 290374 Pac Flt + 10861 UW not dep + 5132 Total UW deployed
 MAPE=14.7%

Predictor	Coef	SE Coef	T	P
Constant	461317	306456	1.51	0.158
Pac Flt	-290374	159699	-1.82	0.094
UW not d	10861	3555	3.06	0.010
Total UW	5132	1578	3.25	0.007

S = 311442 R-Sq = 56.4% R-Sq(adj) = 45.5%

Analysis of Variance

Source	DF	SS	MS	F	P
Regression	3	1.50481E+12	5.01602E+11	5.17	0.016
Residual Error	12	1.16395E+12	96996154337		
Total	15	2.66876E+12			

Source	DF	Seq SS
Pac Flt	1	1.31603E+11
UW not d	1	3.46986E+11
Total UW	1	1.02622E+12

Unusual Observations

Obs	Pac Flt	EMRM	Fit	SE Fit	Residual	St Resid
5	0.00	2541076	1914109	154057	626967	2.32R

R denotes an observation with a large standardized residual

Atlantic and Pacific Fleets:

There were no significant regressions for either Atlantic or Pacific Fleets when the data were considered separately.

ARS Class

SO

Combined

Regression Analysis: OTHER versus two digit year, Pac Flt

The regression equation is

$$\text{OTHER} = 349315 + 69185 \text{ two digit year} + 181906 \text{ Pac Flt}$$

MAPE = 18.6%

Predictor	Coef	SE Coef	T	P
Constant	349315	32911	10.61	0.000
two digi	69185	19001	3.64	0.002
Pac Flt	181906	50273	3.62	0.003

S = 104075 R-Sq = 68.4% R-Sq(adj) = 64.2%

Analysis of Variance

Source	DF	SS	MS	F	P
Regression	2	3.51912E+11	1.75956E+11	16.24	0.000
Residual Error	15	1.62474E+11	10831580731		
Total	17	5.14386E+11			

Source	DF	Seq SS
two digi	1	2.10099E+11
Pac Flt	1	1.41813E+11

Unusual Observations

Obs	two digi	OTHER	Fit	SE Fit	Residual	St Resid
14	2.00	890900	669589	46544	221311	2.38R

R denotes an observation with a large standardized residual

Pacific Fleet

Regression Analysis: OTHER versus two digit year

The regression equation is

$$\text{OTHER} = 498460 + 134705 \text{ two digit year}$$

MAPE = 13.1%

Predictor	Coef	SE Coef	T	P
Constant	498460	41578	11.99	0.000
two digi	134705	33948	3.97	0.007

S = 107353 R-Sq = 72.4% R-Sq(adj) = 67.8%

Analysis of Variance

Source	DF	SS	MS	F	P
Regression	1	1.81454E+11	1.81454E+11	15.74	0.007
Residual Error	6	69147958500	11524659750		
Total	7	2.50602E+11			

Atlantic Fleet

Regression Analysis: OTHER versus two digit year

The regression equation is

$$\text{OTHER} = 349315 + 36424 \text{ two digit year}$$

MAPE = 13.0%

Predictor	Coef	SE Coef	T	P
Constant	349315	19017	18.37	0.000
two digi	36424	13447	2.71	0.027

S = 60137 R-Sq = 47.8% R-Sq(adj) = 41.3%

Analysis of Variance

Source	DF	SS	MS	F	P
Regression	1	26534592610	26534592610	7.34	0.027
Residual Error	8	28931779187	3616472398		
Total	9	55466371796			

SR

Combined

Regression Analysis: EMRM versus two digit year, Pac Flt

The regression equation is

$$\text{EMRM} = 414091 + 57674 \text{ two digit year} + 252672 \text{ Pac Flt}$$

MAPE = 13.6%

Predictor	Coef	SE Coef	T	P
Constant	414091	35361	11.71	0.000
two digi	57674	20415	2.83	0.013
Pac Flt	252672	54014	4.68	0.000

S = 111820 R-Sq = 70.7% R-Sq(adj) = 66.8%

Analysis of Variance

Source	DF	SS	MS	F	P
Regression	2	4.52002E+11	2.26001E+11	18.07	0.000
Residual Error	15	1.87555E+11	12503699720		
Total	17	6.39557E+11			

Source	DF	Seq SS
two digi	1	1.78388E+11
Pac Flt	1	2.73614E+11

Unusual Observations

Obs	two digi	EMRM	Fit	SE Fit	Residual	St Resid
12	0.00	914200	666763	40831	247437	2.38R
15	-1.00	379800	609088	50007	-229288	-2.29R

R denotes an observation with a large standardized residual

Atlantic Fleet

Regression Analysis: EMRM versus two-digit year

The regression equation is

$$\text{EMRM} = 414091 + 48712 \text{ two digit year}$$

MAPE = 11.9%

Predictor	Coef	SE Coef	T	P
Constant	414091	21801	18.99	0.000
two digi	48712	15416	3.16	0.013

S = 68940 R-Sq = 55.5% R-Sq(adj) = 50.0%

Analysis of Variance

Source	DF	SS	MS	F	P
Regression	1	47456594338	47456594338	9.99	0.013
Residual Error	8	38022184621	4752773078		
Total	9	85478778958			

Unusual Observations

Obs	two digi	EMRM	Fit	SE Fit	Residual	St Resid
3	0.00	554915	414091	21801	140824	2.15R

R denotes an observation with a large standardized residual

CG-47 Class

SO

Combined

Regression Analysis: OTHER versus 2 digit year, Total_1

The regression equation is

$$\text{OTHER} = 589434 + 86589 \text{ 2 digit year} + 1312 \text{ Total}_1$$

MAPE = 19.0%

Predictor	Coef	SE Coef	T	P
Constant	589434	53255	11.07	0.000
2 digit	86589	14512	5.97	0.000
Total_1	1311.5	397.7	3.30	0.001

S = 210666 R-Sq = 29.8% R-Sq(adj) = 28.6%

Analysis of Variance

Source	DF	SS	MS	F	P
Regression	2	2.23863E+12	1.11932E+12	25.22	0.000
Residual Error	119	5.28124E+12	44380182751		
Total	121	7.51987E+12			

Source	DF	Seq SS
2 digit	1	1.75605E+12
Total_1	1	4.82579E+11

Unusual Observations

Obs	2 digit	OTHER	Fit	SE Fit	Residual	St Resid
16	-1.00	1164800	746792	36467	418008	2.01R
19	2.00	1993500	930489	32133	1063011	5.11R
40	-1.00	1166000	704823	28957	461177	2.21R
47	2.00	1507000	959343	32949	547657	2.63R
59	2.00	1503200	961966	33137	541234	2.60R

R denotes an observation with a large standardized residual

Regression Analysis: OTHER versus 2 digit year, Pac Flt, Total_1

The regression equation is

$$\text{OTHER} = 519990 + 70221 \text{ 2 digit year} + 244877 \text{ Pac Flt} + 1061 \text{ Total}_1$$

MAPE =14.3%

Predictor	Coef	SE Coef	T	P
Constant	519990	44946	11.57	0.000
2 digit	70221	12183	5.76	0.000
Pac Flt	244877	32596	7.51	0.000
Total_1	1061.0	330.2	3.21	0.002

S = 174000 R-Sq = 52.5% R-Sq(adj) = 51.3%

Analysis of Variance

Source	DF	SS	MS	F	P
Regression	3	3.94731E+12	1.31577E+12	43.46	0.000
Residual Error	118	3.57256E+12	30275915803		
Total	121	7.51987E+12			

Source	DF	Seq SS
2 digit	1	1.75605E+12
Pac Flt	1	1.87869E+12
Total_1	1	3.12569E+11

Unusual Observations

Obs	2 digit	OTHER	Fit	SE Fit	Residual	St Resid
19	2.00	1993500	1041112	30352	952388	5.56R
47	2.00	1507000	1064453	30601	442547	2.58R
59	2.00	1503200	1066575	30708	436625	2.55R
92	2.00	1338206	865198	38919	473008	2.79R
112	2.00	1244372	873686	40481	370686	2.19R

R denotes an observation with a large standardized residual

Regression Analysis: OTHER versus 2 digit year, Pac Flt

The regression equation is

$$\text{OTHER} = 648018 + 72977 \text{ 2 digit year} + 255457 \text{ Pac Flt}$$

MAPE = 14.7%

Predictor	Coef	SE Coef	T	P
Constant	648018	21596	30.01	0.000
2 digit	72977	12620	5.78	0.000
Pac Flt	255457	33676	7.59	0.000

S = 180688 R-Sq = 48.3% R-Sq(adj) = 47.5%

Analysis of Variance

Source	DF	SS	MS	F	P
Regression	2	3.63474E+12	1.81737E+12	55.67	0.000
Residual Error	119	3.88513E+12	32648128005		
Total	121	7.51987E+12			

Source	DF	Seq SS
2 digit	1	1.75605E+12
Pac Flt	1	1.87869E+12

Unusual Observations

Obs	2 digit	OTHER	Fit	SE Fit	Residual	St Resid
19	2.00	1993500	1049429	31404	944071	5.31R
47	2.00	1507000	1049429	31404	457571	2.57R
59	2.00	1503200	1049429	31404	453771	2.55R
92	2.00	1338206	793972	33218	544234	3.06R
112	2.00	1244372	793972	33218	450400	2.54R

R denotes an observation with a large standardized residual

Regression Analysis: OTHER versus 2 digit year

The regression equation is

$$\text{OTHER} = 753079 + 90914 \text{ 2 digit year}$$

MAPE 20.25%

Predictor	Coef	SE Coef	T	P
Constant	753079	20099	37.47	0.000
2 digit	90914	15036	6.05	0.000

S = 219162 R-Sq = 23.4% R-Sq(adj) = 22.7%

Analysis of Variance

Source	DF	SS	MS	F	P
Regression	1	1.75605E+12	1.75605E+12	36.56	0.000
Residual Error	120	5.76382E+12	48031838224		
Total	121	7.51987E+12			

Unusual Observations

Obs	2 digit	OTHER	Fit	SE Fit	Residual	St Resid
16	-1.00	1164800	662165	26952	502635	2.31R
19	2.00	1993500	934907	33400	1058593	4.89R
40	-1.00	1166000	662165	26952	503835	2.32R
47	2.00	1507000	934907	33400	572093	2.64R
59	2.00	1503200	934907	33400	568293	2.62R

R denotes an observation with a large standardized residual

Atlantic Fleet

Regression Analysis: OTHER versus 2 digit year, UW not dep, Total Deploy

The regression equation is

OTHER = 545267 + 65314 2 digit year + 973 UW not dep + 599 Total Deployed UW
MAPE = 20.1%

Predictor	Coef	SE Coef	T	P
Constant	545267	45975	11.86	0.000
2 digit	65314	10773	6.06	0.000
UW not d	973.2	447.5	2.17	0.033
Total De	598.5	312.6	1.91	0.060

S = 127072 R-Sq = 40.4% R-Sq(adj) = 37.7%

Analysis of Variance

Source	DF	SS	MS	F	P
Regression	3	7.21593E+11	2.40531E+11	14.90	0.000
Residual Error	66	1.06572E+12	16147266502		
Total	69	1.78731E+12			

Source	DF	Seq SS
2 digit	1	6.27604E+11
UW not d	1	34807500612
Total De	1	59181828131

Unusual Observations

Obs	2 digit	OTHER	Fit	SE Fit	Residual	St Resid
4	1.00	543842	788680	45201	-244838	-2.06R
40	2.00	1338206	836748	34847	501458	4.10R
60	2.00	1244372	816430	38875	427942	3.54R

R denotes an observation with a large standardized residual

Regression Analysis: OTHER versus 2 digit year, Total_1

The regression equation is

OTHER = 566698 + 65111 2 digit year + 674 Total_1
MAPE 15.4%

Predictor	Coef	SE Coef	T	P
Constant	566698	39351	14.40	0.000
2 digit	65111	10757	6.05	0.000
Total_1	673.9	300.9	2.24	0.028

S = 126900 R-Sq = 39.6% R-Sq(adj) = 37.8%

Analysis of Variance

Source	DF	SS	MS	F	P
Regression	2	7.08373E+11	3.54187E+11	21.99	0.000
Residual Error	67	1.07894E+12	16103571911		
Total	69	1.78731E+12			

Source	DF	Seq SS
2 digit	1	6.27604E+11
Total_1	1	80769599814

Unusual Observations

Obs	2 digit	OTHER	Fit	SE Fit	Residual	St Resid
40	2.00	1338206	826982	33089	511224	4.17R
60	2.00	1244372	832373	34605	411999	3.37R

R denotes an observation with a large standardized residual

Regression Analysis: OTHER versus 2 digit year

The regression equation is
 OTHER = 648018 + 66954 2 digit year
 MAPE 15.1%

Predictor	Coef	SE Coef	T	P
Constant	648018	15609	41.52	0.000
2 digit	66954	11037	6.07	0.000

S = 130593 R-Sq = 35.1% R-Sq(adj) = 34.2%

Analysis of Variance

Source	DF	SS	MS	F	P
Regression	1	6.27604E+11	6.27604E+11	36.80	0.000
Residual Error	68	1.15971E+12	17054542910		
Total	69	1.78731E+12			

Unusual Observations

Obs	2 digit	OTHER	Fit	SE Fit	Residual	St Resid
40	2.00	1338206	781927	27035	556279	4.35R
60	2.00	1244372	781927	27035	462445	3.62R

R denotes an observation with a large standardized residual

Pacific Fleet

Regression Analysis: OTHER versus 2 digit year, Total_1

The regression equation is
 OTHER = 667532 + 81913 2 digit year + 1754 Total_1
 MAPE = 36.2

Predictor	Coef	SE Coef	T	P
Constant	667532	97636	6.84	0.000
2 digit	81913	27510	2.98	0.005
Total_1	1754.4	700.8	2.50	0.016

S = 221414 R-Sq = 24.7% R-Sq(adj) = 21.6%

Analysis of Variance

Source	DF	SS	MS	F	P
Regression	2	7.87393E+11	3.93696E+11	8.03	0.001
Residual Error	49	2.40217E+12	49023976006		
Total	51	3.18957E+12			

Source	DF	Seq SS
2 digit	1	4.80164E+11
Total_1	1	3.07229E+11

Unusual Observations

Obs	2 digit	OTHER	Fit	SE Fit	Residual	St Resid
4	2.00	1993500	1055917	51639	937583	4.35R

R denotes an observation with a large standardized residual

Regression Analysis: OTHER versus 2 digit year

The regression equation is

$$\text{OTHER} = 896989 + 85948 \text{ 2 digit year}$$

MAPE =17.1%

Predictor	Coef	SE Coef	T	P
Constant	896989	35362	25.37	0.000
2 digit	85948	28873	2.98	0.004

S = 232783 R-Sq = 15.1% R-Sq(adj) = 13.4%

Analysis of Variance

Source	DF	SS	MS	F	P
Regression	1	4.80164E+11	4.80164E+11	8.86	0.004
Residual Error	50	2.70940E+12	54188067358		
Total	51	3.18957E+12			

Unusual Observations

Obs	2 digit	OTHER	Fit	SE Fit	Residual	St Resid
4	2.00	1993500	1068886	54017	924614	4.08R

R denotes an observation with a large standardized residual

SR

Combined

Regression Analysis: EMRM versus 2 digit year, UW not dep, Total Deploy

The regression equation is

$$\text{EMRM} = 2274423 + 279975 \text{ 2 digit year} + 3268 \text{ UW not dep} + 2655 \text{ Total Deployed UW}$$

MAPE = 13.2%

Predictor	Coef	SE Coef	T	P
Constant	2274423	131630	17.28	0.000
2 digit	279975	32386	8.64	0.000
UW not d	3268	1245	2.63	0.010
Total De	2654.6	896.8	2.96	0.004

S = 469704 R-Sq = 43.2% R-Sq(adj) = 41.8%

Analysis of Variance

Source	DF	SS	MS	F	P
Regression	3	1.98232E+13	6.60772E+12	29.95	0.000
Residual Error	118	2.60334E+13	2.20622E+11		
Total	121	4.58565E+13			

Source	DF	Seq SS
2 digit	1	1.76414E+13
UW not d	1	2.48661E+11
Total De	1	1.93316E+12

Unusual Observations

Obs	2 digit	EMRM	Fit	SE Fit	Residual	St Resid
16	-1.00	3817800	2488203	116206	1329597	2.92R
28	-1.00	3660800	2397947	101141	1262853	2.75R
39	2.00	2446500	3505634	115104	-1059134	-2.33R
53	0.00	1672000	2651015	43076	-979015	-2.09R
87	2.00	4436981	3371686	85829	1065295	2.31R
96	1.00	4169321	3075767	68087	1093554	2.35R
97	2.00	4176974	3111317	82272	1065657	2.30R

R denotes an observation with a large standardized residual

Regression Analysis: EMRM versus 2 digit year, Pac Flt,

The regression equation is

$$\text{EMRM} = 2351259 + 290770 \text{ 2 digit year} - 171724 \text{ Pac Flt} + 3011 \text{ UW not dep} + 2896 \text{ Total Deployed UW}$$

MAPE = 13.0%

Predictor	Coef	SE Coef	T	P
Constant	2351259	136262	17.26	0.000
2 digit	290770	32525	8.94	0.000
Pac Flt	-171724	89967	-1.91	0.059
UW not d	3011	1238	2.43	0.017
Total De	2896.4	895.9	3.23	0.002

S = 464530 R-Sq = 44.9% R-Sq(adj) = 43.1%

Analysis of Variance

Source	DF	SS	MS	F	P
Regression	4	2.06094E+13	5.15234E+12	23.88	0.000
Residual Error	117	2.52472E+13	2.15788E+11		
Total	121	4.58565E+13			

Source	DF	Seq SS
2 digit	1	1.76414E+13
Pac Flt	1	6.07016E+11
UW not d	1	1.05585E+11
Total De	1	2.25540E+12

Unusual Observations

Obs	2 digit	EMRM	Fit	SE Fit	Residual	St Resid
16	-1.00	3817800	2427502	119245	1390298	3.10R
28	-1.00	3660800	2329023	106345	1331777	2.95R
39	2.00	2446500	3445809	118072	-999309	-2.22R
87	2.00	4436981	3465284	98029	971697	2.14R
91	1.00	1973525	2900988	72914	-927463	-2.02R
96	1.00	4169321	3171532	83973	997789	2.18R
97	2.00	4176974	3193392	92029	983582	2.16R
105	0.00	1965420	2908092	82574	-942672	-2.06R

R denotes an observation with a large standardized residual

Regression Analysis: EMRM versus 2 digit year, Total_1

The regression equation is

$$\text{EMRM} = 2309035 + 279134 \text{ 2 digit year} + 2736 \text{ Total}_1$$

MAPE = 13.4%

Predictor	Coef	SE Coef	T	P
Constant	2309035	118423	19.50	0.000
2 digit	279134	32271	8.65	0.000
Total_1	2735.9	884.4	3.09	0.002

S = 468461 R-Sq = 43.1% R-Sq(adj) = 42.1%

Analysis of Variance

Source	DF	SS	MS	F	P
Regression	2	1.97413E+13	9.87065E+12	44.98	0.000
Residual Error	119	2.61152E+13	2.19456E+11		
Total	121	4.58565E+13			

Source	DF	Seq SS
2 digit	1	1.76414E+13
Total_1	1	2.09994E+12

Unusual Observations

Obs	2 digit	EMRM	Fit	SE Fit	Residual	St Resid
16	-1.00	3817800	2538782	81091	1279018	2.77R
28	-1.00	3660800	2445761	63622	1215039	2.62R
39	2.00	2446500	3504772	114790	-1058272	-2.33R
53	0.00	1672000	2651025	42962	-979025	-2.10R
87	2.00	4436981	3359769	83349	1077212	2.34R
96	1.00	4169321	3080635	67438	1088686	2.35R
97	2.00	4176974	3105328	81467	1071646	2.32R

R denotes an observation with a large standardized residual

Regression Analysis: EMRM versus 2 digit year, Pac Flt, Total_1

The regression equation is

$$\text{EMRM} = 2358455 + 290782 \text{ 2 digit year} - 174269 \text{ Pac Flt} + 2914 \text{ Total}_1$$

MAPE = 13.1%

Predictor	Coef	SE Coef	T	P
Constant	2358455	119491	19.74	0.000
2 digit	290782	32388	8.98	0.000
Pac Flt	-174269	86657	-2.01	0.047
Total_1	2914.2	877.8	3.32	0.001

S = 462582 R-Sq = 44.9% R-Sq(adj) = 43.5%

Analysis of Variance

Source	DF	SS	MS	F	P
Regression	3	2.06067E+13	6.86889E+12	32.10	0.000
Residual Error	118	2.52499E+13	2.13982E+11		
Total	121	4.58565E+13			

Source	DF	Seq SS
2 digit	1	1.76414E+13
Pac Flt	1	6.07016E+11
Total_1	1	2.35830E+12

Unusual Observations

Obs	2 digit	EMRM	Fit	SE Fit	Residual	St Resid
16	-1.00	3817800	2435454	95141	1382346	3.05R
28	-1.00	3660800	2336370	83101	1324430	2.91R
39	2.00	2446500	3444771	117211	-998271	-2.23R
87	2.00	4436981	3464585	97418	972396	2.15R
91	1.00	1973525	2899863	71910	-926338	-2.03R
96	1.00	4169321	3173803	81122	995518	2.19R
97	2.00	4176974	3193560	91631	983414	2.17R
105	0.00	1965420	2909248	81576	-943828	-2.07R

R denotes an observation with a large standardized residual

Regression Analysis: EMRM versus 2 digit year

The regression equation is

$$\text{EMRM} = 2650403 + 288156 \text{ 2 digit year}$$

MAPE 14.0%

Predictor	Coef	SE Coef	T	P
Constant	2650403	44469	59.60	0.000
2 digit	288156	33267	8.66	0.000

S = 484898 R-Sq = 38.5% R-Sq(adj) = 38.0%

Analysis of Variance

Source	DF	SS	MS	F	P
Regression	1	1.76414E+13	1.76414E+13	75.03	0.000
Residual Error	120	2.82152E+13	2.35127E+11		
Total	121	4.58565E+13			

Unusual Observations

Obs	2 digit	EMRM	Fit	SE Fit	Residual	St Resid
16	-1.00	3817800	2362247	59632	1455553	3.02R
28	-1.00	3660800	2362247	59632	1298553	2.70R
53	0.00	1672000	2650403	44469	-978403	-2.03R
87	2.00	4436981	3226716	73898	1210265	2.53R
91	1.00	1973525	2938559	51113	-965034	-2.00R
96	1.00	4169321	2938559	51113	1230762	2.55R

R denotes an observation with a large standardized residual

Regression Analysis: EMRM versus 2 digit year, Pac Flt

The regression equation is

$$\text{EMRM} = 2710122 + 298352 \text{ 2 digit year} - 145208 \text{ Pac Flt}$$

MAPE = 13.8%

Predictor	Coef	SE Coef	T	P
Constant	2710122	57570	47.08	0.000
2 digit	298352	33641	8.87	0.000
Pac Flt	-145208	89771	-1.62	0.108

S = 481665 R-Sq = 39.8% R-Sq(adj) = 38.8%

Analysis of Variance

Source	DF	SS	MS	F	P
Regression	2	1.82484E+13	9.12418E+12	39.33	0.000
Residual Error	119	2.76082E+13	2.32001E+11		
Total	121	4.58565E+13			

Source	DF	Seq SS
2 digit	1	1.76414E+13
Pac Flt	1	6.07016E+11

Unusual Observations

Obs	2 digit	EMRM	Fit	SE Fit	Residual	St Resid
16	-1.00	3817800	2266562	83713	1551238	3.27R
28	-1.00	3660800	2266562	83713	1394238	2.94R
87	2.00	4436981	3306827	88550	1130154	2.39R
91	1.00	1973525	3008474	66678	-1034949	-2.17R
96	1.00	4169321	3008474	66678	1160847	2.43R

R denotes an observation with a large standardized residual

Atlantic Fleet

Regression Analysis: EMRM versus 2 digit year, UW not dep, Total Deploy

The regression equation is

$$\text{EMRM} = 2363303 + 314474 \text{ 2 digit year} + 3231 \text{ UW not dep} + 2131 \text{ Total Deployed UW}$$

MAPE =14.1%

Predictor	Coef	SE Coef	T	P
Constant	2363303	172173	13.73	0.000
2 digit	314474	40346	7.79	0.000
UW not d	3231	1676	1.93	0.058
Total De	2131	1171	1.82	0.073

S = 475875 R-Sq = 50.8% R-Sq(adj) = 48.6%

Analysis of Variance

Source	DF	SS	MS	F	P
Regression	3	1.54625E+13	5.15415E+12	22.76	0.000
Residual Error	66	1.49461E+13	2.26457E+11		
Total	69	3.04086E+13			

Source	DF	Seq SS
2 digit	1	1.43640E+13
UW not d	1	3.47804E+11
Total De	1	7.50619E+11

Unusual Observations

Obs	2 digit	EMRM	Fit	SE Fit	Residual	St Resid
35	2.00	4436981	3482607	115979	954374	2.07R
39	1.00	1973525	2955675	83567	-982150	-2.10R
44	1.00	4169321	3139536	100402	1029785	2.21R

R denotes an observation with a large standardized residual

Regression Analysis: EMRM versus 2 digit year, Total_1

The regression equation is

$$\text{EMRM} = 2426207 + 313876 \text{ 2 digit year} + 2353 \text{ Total}_1$$

MAPE = 14.3%

Predictor	Coef	SE Coef	T	P
Constant	2426207	147019	16.50	0.000
2 digit	313876	40187	7.81	0.000
Total_1	2353	1124	2.09	0.040

S = 474106 R-Sq = 50.5% R-Sq(adj) = 49.0%

Analysis of Variance

Source	DF	SS	MS	F	P
Regression	2	1.53486E+13	7.67428E+12	34.14	0.000
Residual Error	67	1.50601E+13	2.24777E+11		
Total	69	3.04086E+13			

Source	DF	Seq SS
2 digit	1	1.43640E+13
Total_1	1	9.84523E+11

Unusual Observations

Obs	2 digit	EMRM	Fit	SE Fit	Residual	St Resid
35	2.00	4436981	3477462	115322	959519	2.09R
39	1.00	1973525	2942423	81149	-968898	-2.07R
44	1.00	4169321	3163586	94151	1005735	2.16R

R denotes an observation with a large standardized residual

Regression Analysis: EMRM versus 2 digit year

The regression equation is

$$\text{EMRM} = 2710122 + 320313 \text{ 2 digit year}$$

MAPE = 14.5%

Predictor	Coef	SE Coef	T	P
Constant	2710122	58058	46.68	0.000
2 digit	320313	41053	7.80	0.000

S = 485746 R-Sq = 47.2% R-Sq(adj) = 46.5%

Analysis of Variance

Source	DF	SS	MS	F	P
Regression	1	1.43640E+13	1.43640E+13	60.88	0.000
Residual Error	68	1.60446E+13	2.35950E+11		
Total	69	3.04086E+13			

Unusual Observations

Obs	2 digit	EMRM	Fit	SE Fit	Residual	St Resid
35	2.00	4436981	3350747	100559	1086234	2.29R
39	1.00	1973525	3030435	71106	-1056910	-2.20R
44	1.00	4169321	3030435	71106	1138886	2.37R

R denotes an observation with a large standardized residual

Pacific Fleet

Regression Analysis: EMRM versus 2 digit year, UW not dep, Total Deploy

The regression equation is

$$\text{EMRM} = 2107506 + 242910 \text{ 2 digit year} + 3367 \text{ UW not dep} + 3944 \text{ Total Deployed UW}$$

MAPE = 11.2%

Predictor	Coef	SE Coef	T	P
Constant	2107506	210969	9.99	0.000
2 digit	242910	56162	4.33	0.000
UW not d	3367	1913	1.76	0.085
Total De	3944	1433	2.75	0.008

S = 451737 R-Sq = 36.6% R-Sq(adj) = 32.6%

Analysis of Variance

Source	DF	SS	MS	F	P
Regression	3	5.65227E+12	1.88409E+12	9.23	0.000
Residual Error	48	9.79518E+12	2.04066E+11		
Total	51	1.54475E+13			

Source	DF	Seq SS
2 digit	1	4.09680E+12
UW not d	1	10478981580
Total De	1	1.54499E+12

Unusual Observations

Obs	2 digit	EMRM	Fit	SE Fit	Residual	St Resid
1	-1.00	3817800	2598187	158763	1219613	2.88R
13	-1.00	3660800	2464090	137809	1196710	2.78R
24	2.00	2446500	3462659	175798	-1016159	-2.44R
44	2.00	4108000	3130497	122787	977503	2.25R

R denotes an observation with a large standardized residual

Regression Analysis: EMRM versus 2 digit year, Total_1

The regression equation is

$$\text{EMRM} = 2078288 + 242080 \text{ 2 digit year} + 3901 \text{ Total}_1$$

MAPE = 11.2%

Predictor	Coef	SE Coef	T	P
Constant	2078288	197520	10.52	0.000
2 digit	242080	55654	4.35	0.000
Total_1	3901	1418	2.75	0.008

S = 447927 R-Sq = 36.4% R-Sq(adj) = 33.8%

Analysis of Variance

Source	DF	SS	MS	F	P
Regression	2	5.61618E+12	2.80809E+12	14.00	0.000
Residual Error	49	9.83127E+12	2.00638E+11		
Total	51	1.54475E+13			

Source	DF	Seq SS
2 digit	1	4.09680E+12
Total_1	1	1.51938E+12

Unusual Observations

Obs	2 digit	EMRM	Fit	SE Fit	Residual	St Resid
1	-1.00	3817800	2561872	132102	1255928	2.93R
13	-1.00	3660800	2429224	109153	1231576	2.83R
24	2.00	2446500	3471479	173070	-1024979	-2.48R
38	0.00	1672000	2565966	68539	-893966	-2.02R
44	2.00	4108000	3155464	106574	952536	2.19R

R denotes an observation with a large standardized residual

Regression Analysis: EMRM versus 2 digit year

The regression equation is

$$\text{EMRM} = 2588564 + 251053 \text{ 2 digit year}$$

MAPE = 13.0%

Predictor	Coef	SE Coef	T	P
Constant	2588564	72379	35.76	0.000
2 digit	251053	59097	4.25	0.000

S = 476459 R-Sq = 26.5% R-Sq(adj) = 25.1%

Analysis of Variance

Source	DF	SS	MS	F	P
Regression	1	4.09680E+12	4.09680E+12	18.05	0.000
Residual Error	50	1.13507E+13	2.27013E+11		
Total	51	1.54475E+13			

Unusual Observations

Obs	2 digit	EMRM	Fit	SE Fit	Residual	St Resid
1	-1.00	3817800	2337511	110561	1480289	3.19R
13	-1.00	3660800	2337511	110561	1323289	2.86R
44	2.00	4108000	3090670	110561	1017330	2.20R

R denotes an observation with a large standardized residual

CVN-68 Class

SO:

Atlantic Fleet

Regression Analysis: OTHER versus 2 digit year, Total_1

The regression equation is

$$\text{OTHER} = 5204351 + 781017 \text{ 2 digit year} + 20101 \text{ Total}_1$$

MAPE = 16.2%

Predictor	Coef	SE Coef	T	P
Constant	5204351	806073	6.46	0.000
2 digit	781017	262038	2.98	0.008
Total_1	20101	5368	3.74	0.002

S = 1599008 R-Sq = 63.3% R-Sq(adj) = 59.0%

Analysis of Variance

Source	DF	SS	MS	F	P
Regression	2	7.50910E+13	3.75455E+13	14.68	0.000
Residual Error	17	4.34660E+13	2.55683E+12		
Total	19	1.18557E+14			

Source	DF	Seq SS
2 digit	1	3.92460E+13
Total_1	1	3.58451E+13

Unusual Observations

Obs	2 digit	OTHER	Fit	SE Fit	Residual	St Resid
2	2.00	13912179	10967421	724042	2944758	2.07R
18	-2.00	10058182	6717716	621856	3340466	2.27R

R denotes an observation with a large standardized residual

Regression Analysis: OTHER versus Total_1

The regression equation is

$$\text{OTHER} = 4575298 + 23681 \text{ Total}_1$$

MAPE = 18.6%

Predictor	Coef	SE Coef	T	P
Constant	4575298	932889	4.90	0.000
Total_1	23681	6274	3.77	0.001

S = 1917464 R-Sq = 44.2% R-Sq(adj) = 41.1%

Analysis of Variance

Source	DF	SS	MS	F	P
Regression	1	5.23771E+13	5.23771E+13	14.25	0.001
Residual Error	18	6.61800E+13	3.67667E+12		
Total	19	1.18557E+14			

Unusual Observations

Obs	Total_1	OTHER	Fit	SE Fit	Residual	St Resid
2	209	13912179	9524728	645706	4387451	2.43R

R denotes an observation with a large standardized residual

SR:

Regression Analysis: EMRM versus 2 digit year, UW not dep, Total UW dep

The regression equation is

$$\text{EMRM} = 2977027 + 681646 \text{ 2 digit year} + 29933 \text{ UW not dep} + 21332 \text{ Total UW deployed}$$

MAPE = 27.0%

Predictor	Coef	SE Coef	T	P
Constant	2977027	1086374	2.74	0.015
2 digit	681646	322751	2.11	0.051
UW not d	29933	11066	2.70	0.016
Total UW	21332	7056	3.02	0.008

S = 1924825 R-Sq = 59.9% R-Sq(adj) = 52.4%

Analysis of Variance

Source	DF	SS	MS	F	P
Regression	3	8.87016E+13	2.95672E+13	7.98	0.002
Residual Error	16	5.92792E+13	3.70495E+12		
Total	19	1.47981E+14			

Source	DF	Seq SS
2 digit	1	3.81828E+13
UW not d	1	1.66560E+13
Total UW	1	3.38628E+13

Unusual Observations

Obs	2 digit	EMRM	Fit	SE Fit	Residual	St Resid
3	2.00	11802664	8081935	964745	3720729	2.23R

R denotes an observation with a large standardized residual

Regression Analysis: EMRM versus 2 digit year, Total_1

The regression equation is

$$\text{EMRM} = 3332599 + 731389 \text{ 2 digit year} + 23395 \text{ Total}_1$$

MAPE = 26.9%

Predictor	Coef	SE Coef	T	P
Constant	3332599	956804	3.48	0.003
2 digit	731389	311038	2.35	0.031
Total_1	23395	6372	3.67	0.002

S = 1898013 R-Sq = 58.6% R-Sq(adj) = 53.7%

Analysis of Variance

Source	DF	SS	MS	F	P
Regression	2	8.67391E+13	4.33696E+13	12.04	0.001
Residual Error	17	6.12417E+13	3.60245E+12		
Total	19	1.47981E+14			

Source	DF	Seq SS
2 digit	1	3.81828E+13
Total_1	1	4.85563E+13

Unusual Observations

Obs	2 digit	EMRM	Fit	SE Fit	Residual	St Resid
3	2.00	11802664	7719718	814950	4082946	2.38R

R denotes an observation with a large standardized residual

Regression Analysis: EMRM versus 2 digit year, UW not dep, Total UW dep

The regression equation is

$$\text{EMRM} = 2977027 + 681646 \text{ 2 digit year} + 29933 \text{ UW not dep} \\ + 21332 \text{ Total UW deployed}$$

MAPE = 27.0%

Predictor	Coef	SE Coef	T	P
Constant	2977027	1086374	2.74	0.015
2 digit	681646	322751	2.11	0.051
UW not d	29933	11066	2.70	0.016
Total UW	21332	7056	3.02	0.008

S = 1924825 R-Sq = 59.9% R-Sq(adj) = 52.4%

Analysis of Variance

Source	DF	SS	MS	F	P
Regression	3	8.87016E+13	2.95672E+13	7.98	0.002
Residual Error	16	5.92792E+13	3.70495E+12		
Total	19	1.47981E+14			

Source	DF	Seq SS
2 digit	1	3.81828E+13
UW not d	1	1.66560E+13
Total UW	1	3.38628E+13

Unusual Observations

Obs	2 digit	EMRM	Fit	SE Fit	Residual	St Resid
3	2.00	11802664	8081935	964745	3720729	2.23R

R denotes an observation with a large standardized residual

Regression Analysis: EMRM versus 2 digit year

The regression equation is

$$\text{EMRM} = 6472983 + 986941 \text{ 2 digit year}$$

MAPE = 30.4%

Predictor	Coef	SE Coef	T	P
Constant	6472983	557870	11.60	0.000
2 digit	986941	394474	2.50	0.022

S = 2469795 R-Sq = 25.8% R-Sq(adj) = 21.7%

Analysis of Variance

Source	DF	SS	MS	F	P
Regression	1	3.81828E+13	3.81828E+13	6.26	0.022
Residual Error	18	1.09798E+14	6.09989E+12		
Total	19	1.47981E+14			

Unusual Observations

Obs	2 digit	EMRM	Fit	SE Fit	Residual	St Resid
4	1.00	1854746	7459924	727373	-5605178	-2.37R

R denotes an observation with a large standardized residual

Regression Analysis: EMRM versus Total_1

The regression equation is
 EMRM = 2743518 + 26748 Total_1
 MAPE = 27.4%

Predictor	Coef	SE Coef	T	P
Constant	2743518	1033093	2.66	0.016
Total_1	26748	6948	3.85	0.001

S = 2123424 R-Sq = 45.2% R-Sq(adj) = 42.1%

Analysis of Variance

Source	DF	SS	MS	F	P
Regression	1	6.68201E+13	6.68201E+13	14.82	0.001
Residual Error	18	8.11607E+13	4.50893E+12		
Total	19	1.47981E+14			

Unusual Observations

Obs	Total_1	EMRM	Fit	SE Fit	Residual	St Resid
3	125	11802664	6087022	477332	5715642	2.76R

R denotes an observation with a large standardized residual

DD-963 Class

SO

Combined

Regression Analysis: OTHER versus Two digit year, Pac Flt

The regression equation is
 OTHER = 541424 + 46157 Two digit year + 415501 Pac Flt
 MAPE = 17.7%

Predictor	Coef	SE Coef	T	P
Constant	541424	25294	21.40	0.000
Two digi	46157	14894	3.10	0.003
Pac Flt	415501	40669	10.22	0.000

S = 199280 R-Sq = 57.2% R-Sq(adj) = 56.4%

Analysis of Variance

Source	DF	SS	MS	F	P
Regression	2	5.47626E+12	2.73813E+12	68.95	0.000
Residual Error	103	4.09041E+12	39712688246		
Total	105	9.56666E+12			

Source	DF	Seq SS
Two digi	1	1.33096E+12
Pac Flt	1	4.14530E+12

Unusual Observations

Obs	Two digi	OTHER	Fit	SE Fit	Residual	St Resid
11	1.00	55250	587581	30874	-532331	-2.70R
64	2.00	209400	1049238	38029	-839838	-4.29R
84	2.00	1754200	1049238	38029	704962	3.60R
103	1.00	1486000	1003081	31417	482919	2.45R

R denotes an observation with a large standardized residual

Regression Analysis: OTHER versus Two digit year, Pac Flt, ...

The regression equation is

$$\text{OTHER} = 331935 + 43634 \text{ Two digit year} + 372565 \text{ Pac Flt} + 1856 \text{ UW not dep} \\ + 1859 \text{ Total UW Deployed}$$

MAPE = 22.8

Predictor	Coef	SE Coef	T	P
Constant	331935	56302	5.90	0.000
Two digi	43634	13709	3.18	0.002
Pac Flt	372565	39323	9.47	0.000
UW not d	1855.9	541.4	3.43	0.001
Total UW	1858.7	419.3	4.43	0.000

S = 183169 R-Sq = 64.6% R-Sq(adj) = 63.2%

Analysis of Variance

Source	DF	SS	MS	F	P
Regression	4	6.17801E+12	1.54450E+12	46.03	0.000
Residual Error	101	3.38865E+12	33551021985		
Total	105	9.56666E+12			

Source	DF	Seq SS
Two digi	1	1.33096E+12
Pac Flt	1	4.14530E+12
UW not d	1	42618236888
Total UW	1	6.59135E+11

Unusual Observations

Obs	Two digi	OTHER	Fit	SE Fit	Residual	St Resid
64	2.00	209400	860437	54173	-651037	-3.72R
75	2.00	1052400	1168520	71408	-116120	-0.69 X
84	2.00	1754200	1079546	41250	674654	3.78R
92	1.00	1395200	1021361	42491	373839	2.10R
97	2.00	1430400	1076147	47759	354253	2.00R

R denotes an observation with a large standardized residual

X denotes an observation whose X value gives it large influence.

Regression Analysis: OTHER versus Two digit year, Pac Flt, ...

The regression equation is

$$\text{OTHER} = 327688 + 43430 \text{ Two digit year} + 375341 \text{ Pac Flt} + 1884 \text{ UW not dep} \\ + 2017 \text{ UW Dep not 17} + 1673 \text{ Code 17}$$

MAPE = 19.5%

Predictor	Coef	SE Coef	T	P
Constant	327688	57412	5.71	0.000
Two digi	43430	13774	3.15	0.002
Pac Flt	375341	40022	9.38	0.000
UW not d	1883.6	547.5	3.44	0.001
UW Dep n	2017.2	563.0	3.58	0.001
Code 17	1673.0	607.5	2.75	0.007

S = 183918 R-Sq = 64.6% R-Sq(adj) = 62.9%

Analysis of Variance

Source	DF	SS	MS	F	P
Regression	5	6.18409E+12	1.23682E+12	36.56	0.000
Residual Error	100	3.38257E+12	33825680316		
Total	105	9.56666E+12			

Source	DF	Seq SS
Two digi	1	1.33096E+12
Pac Flt	1	4.14530E+12
UW not d	1	42618236888
UW Dep n	1	4.08685E+11
Code 17	1	2.56535E+11

Unusual Observations

Obs	Two digi	OTHER	Fit	SE Fit	Residual	St Resid
10	2.00	460448	714532	76990	-254084	-1.52 X
64	2.00	209400	859583	54431	-650183	-3.70R
84	2.00	1754200	1081341	41634	672859	3.76R
92	1.00	1395200	1023024	42845	372176	2.08R
103	1.00	1486000	1125563	44049	360437	2.02R

R denotes an observation with a large standardized residual
 X denotes an observation whose X value gives it large influence

Atlantic Fleet

Regression Analysis: OTHER versus Two digit year, Total_1

The regression equation is

$$\text{OTHER} = 455668 + 39223 \text{ Two digit year} + 749 \text{ Total}_1$$

MAPE = 16.9%

Predictor	Coef	SE Coef	T	P
Constant	455668	45554	10.00	0.000
Two digi	39223	12044	3.26	0.002
Total_1	749.3	373.4	2.01	0.049

S = 135085 R-Sq = 20.6% R-Sq(adj) = 17.9%

Analysis of Variance

Source	DF	SS	MS	F	P
Regression	2	2.83453E+11	1.41727E+11	7.77	0.001
Residual Error	60	1.09488E+12	18247967640		
Total	62	1.37833E+12			

Source	DF	Seq SS
Two digi	1	2.09976E+11
Total_1	1	73477704836

Unusual Observations

Obs	Two digi	OTHER	Fit	SE Fit	Residual	St Resid
2	2.00	351506	619533	31531	-268027	-2.04R
11	1.00	55250	500885	45795	-445635	-3.51R
16	2.00	936921	640513	32853	296408	2.26R
21	1.00	268131	569071	23146	-300940	-2.26R
32	2.00	951775	682473	43652	269302	2.11R
39	-2.00	135903	413938	35406	-278035	-2.13R
46	2.00	877135	596305	33985	280830	2.15R

R denotes an observation with a large standardized residual

Regression Analysis: OTHER versus Two digit year

The regression equation is

$$\text{OTHER} = 540313 + 40771 \text{ Two digit year}$$

MAPE = 16.1%

Predictor	Coef	SE Coef	T	P
Constant	540313	17620	30.66	0.000
Two digi	40771	12314	3.31	0.002

S = 138396 R-Sq = 15.2% R-Sq(adj) = 13.8%

Analysis of Variance

Source	DF	SS	MS	F	P
Regression	1	2.09976E+11	2.09976E+11	10.96	0.002
Residual Error	61	1.16836E+12	19153373168		
Total	62	1.37833E+12			

Unusual Observations

Obs	Two digi	OTHER	Fit	SE Fit	Residual	St Resid
2	2.00	351506	621855	32282	-270349	-2.01R
11	1.00	55250	581084	22906	-525834	-3.85R
16	2.00	936921	621855	32282	315066	2.34R
21	1.00	268131	581084	22906	-312953	-2.29R
32	2.00	951775	621855	32282	329920	2.45R
39	-2.00	135903	458770	28140	-322867	-2.38R

R denotes an observation with a large standardized residual

Pacific Fleet

Regression Analysis: OTHER versus Two digit year, UW not dep, ...

The regression equation is

$$\text{OTHER} = 384708 + 65132 \text{ Two digit year} + 3927 \text{ UW not dep} + 5179 \text{ UW Dep not 17} + 3310 \text{ Code 17}$$

MAPE = 15.9%

Predictor	Coef	SE Coef	T	P
Constant	384708	129295	2.98	0.005
Two digi	65132	29873	2.18	0.036
UW not d	3927	1121	3.50	0.001
UW Dep n	5179	1344	3.85	0.000
Code 17	3309.6	994.5	3.33	0.002

S = 213225 R-Sq = 44.2% R-Sq(adj) = 38.3%

Analysis of Variance

Source	DF	SS	MS	F	P
Regression	4	1.36579E+12	3.41448E+11	7.51	0.000
Residual Error	38	1.72766E+12	45464844900		
Total	42	3.09346E+12			

Source	DF	Seq SS
Two digi	1	1.83851E+11
UW not d	1	2299301338
UW Dep n	1	6.76154E+11
Code 17	1	5.03488E+11

Unusual Observations

Obs	Two digi	OTHER	Fit	SE Fit	Residual	St Resid
1	2.00	209400	660283	103735	-450883	-2.42R
18	-1.00	876700	1091200	127629	-214500	-1.26 X
21	2.00	1754200	1141987	66077	612213	3.02R

R denotes an observation with a large standardized residual
 X denotes an observation whose X value gives it large influence.

Regression Analysis: OTHER versus Two digit year, Total_1

The regression equation is

$$\text{OTHER} = 418276 + 60375 \text{ Two digit year} + 3897 \text{ Total}_1$$

MAPE = 16.0%

Predictor	Coef	SE Coef	T	P
Constant	418276	113922	3.67	0.001
Two digi	60375	29334	2.06	0.046
Total_1	3896.7	792.6	4.92	0.000

S = 212935 R-Sq = 41.4% R-Sq(adj) = 38.4%

Analysis of Variance

Source	DF	SS	MS	F	P
Regression	2	1.27980E+12	6.39901E+11	14.11	0.000
Residual Error	40	1.81365E+12	45341341870		
Total	42	3.09346E+12			

Source	DF	Seq SS
Two digi	1	1.83851E+11
Total_1	1	1.09595E+12

Unusual Observations

Obs	Two digi	OTHER	Fit	SE Fit	Residual	St Resid
1	2.00	209400	683203	96129	-473803	-2.49R
21	2.00	1754200	1143014	57513	611186	2.98R

R denotes an observation with a large standardized residual

Regression Analysis: OTHER versus Total_1

The regression equation is

$$\text{OTHER} = 448379 + 3882 \text{ Total}_1$$

MAPE = 17.7%

Predictor	Coef	SE Coef	T	P
Constant	448379	117353	3.82	0.000
Total_1	3881.9	823.2	4.72	0.000

S = 221179 R-Sq = 35.2% R-Sq(adj) = 33.6%

Analysis of Variance

Source	DF	SS	MS	F	P
Regression	1	1.08773E+12	1.08773E+12	22.23	0.000
Residual Error	41	2.00573E+12	48920143282		
Total	42	3.09346E+12			

Unusual Observations

Obs	Total_1	OTHER	Fit	SE Fit	Residual	St Resid
1	37	209400	592009	88612	-382609	-1.89 X
21	155	1754200	1050073	36997	704127	3.23R

R denotes an observation with a large standardized residual
 X denotes an observation whose X value gives it large influence.

SR

Combined

Regression Analysis: EMRM versus Two digit year

The regression equation is
 EMRM = 2071522 + 165560 Two digit year
 MAPE = 21.7

Predictor	Coef	SE Coef	T	P
Constant	2071522	60477	34.25	0.000
Two digi	165560	45053	3.67	0.000

S = 621897 R-Sq = 11.5% R-Sq(adj) = 10.6%

Analysis of Variance

Source	DF	SS	MS	F	P
Regression	1	5.22269E+12	5.22269E+12	13.50	0.000
Residual Error	104	4.02227E+13	3.86756E+11		
Total	105	4.54453E+13			

Unusual Observations

Obs	Two digi	EMRM	Fit	SE Fit	Residual	St Resid
11	1.00	41797	2237082	73615	-2195285	-3.55R
21	1.00	698013	2237082	73615	-1539069	-2.49R
39	-2.00	338476	1740401	110964	-1401925	-2.29R
64	2.00	61000	2402642	106022	-2341642	-3.82R
94	1.00	929000	2237082	73615	-1308082	-2.12R

R denotes an observation with a large standardized residual

Regression Analysis: EMRM versus Two digit year, UW not dep, ...

The regression equation is
 EMRM = 1530061 + 152196 Two digit year + 4881 UW not dep + 3923 UW Dep not 17
 + 3683 Code 17
 MAPE = 21.2

Predictor	Coef	SE Coef	T	P
Constant	1530061	185337	8.26	0.000
Two digi	152196	43831	3.47	0.001
UW not d	4881	1791	2.73	0.008
UW Dep n	3923	1834	2.14	0.035
Code 17	3683	1890	1.95	0.054

S = 601844 R-Sq = 19.5% R-Sq(adj) = 16.3%

Analysis of Variance

Source	DF	SS	MS	F	P
Regression	4	8.86145E+12	2.21536E+12	6.12	0.000
Residual Error	101	3.65839E+13	3.62217E+11		
Total	105	4.54453E+13			

Source	DF	Seq SS
Two digi	1	5.22269E+12
UW not d	1	6.35045E+11
UW Dep n	1	1.62860E+12
Code 17	1	1.37511E+12

Unusual Observations

Obs	Two digi	EMRM	Fit	SE Fit	Residual	St Resid
11	1.00	41797	1713642	184209	-1671845	-2.92R
21	1.00	698013	2117589	95144	-1419576	-2.39R
34	2.00	3372169	1946717	178000	1425452	2.48R
35	1.00	3189538	1872619	136212	1316919	2.25R
46	2.00	3421375	2239581	122710	1181794	2.01R
64	2.00	61000	2015052	160434	-1954052	-3.37R
93	2.00	1406700	2636851	135500	-1230151	-2.10R
94	1.00	929000	2296652	101772	-1367652	-2.31R

R denotes an observation with a large standardized residual

Regression Analysis: EMRM versus Two digit ye, UW not dep, Total UW Dep

The regression equation is

$$\text{EMRM} = 1532637 + 152182 \text{ Two digit year} + 4860 \text{ UW not dep} + 3807 \text{ Total UW Deployed}$$

MAPE = 22.1

Predictor	Coef	SE Coef	T	P
Constant	1532637	182299	8.41	0.000
Two digi	152182	43617	3.49	0.001
UW not d	4860	1768	2.75	0.007
Total UW	3807	1316	2.89	0.005

S = 598912 R-Sq = 19.5% R-Sq(adj) = 17.1%

Analysis of Variance

Source	DF	SS	MS	F	P
Regression	3	8.85841E+12	2.95280E+12	8.23	0.000
Residual Error	102	3.65869E+13	3.58695E+11		
Total	105	4.54453E+13			

Source	DF	Seq SS
Two digi	1	5.22269E+12
UW not d	1	6.35045E+11
Total UW	1	3.00067E+12

Unusual Observations

Obs	Two digi	EMRM	Fit	SE Fit	Residual	St Resid
11	1.00	41797	1715274	182453	-1673477	-2.93R
21	1.00	698013	2113325	82583	-1415312	-2.39R
34	2.00	3372169	1948793	175692	1423376	2.49R
35	1.00	3189538	1874378	134194	1315160	2.25R
46	2.00	3421375	2240422	121770	1180953	2.01R
64	2.00	61000	2016840	158467	-1955840	-3.39R
75	2.00	1808200	2823681	224215	-1015481	-1.83 X
93	2.00	1406700	2637047	134823	-1230347	-2.11R
94	1.00	929000	2299690	95751	-1370690	-2.32R

R denotes an observation with a large standardized residual
 X denotes an observation whose X value gives it large influence.

Atlantic Fleet

Regression Analysis: EMRM versus Two digit year, Total_1

The regression equation is

$$\text{EMRM} = 1720829 + 228806 \text{ Two digit year} + 3050 \text{ Total}_1$$

MAPE = 29.4%

Predictor	Coef	SE Coef	T	P
Constant	1720829	199173	8.64	0.000
Two digi	228806	52659	4.35	0.000
Total_1	3050	1633	1.87	0.067

S = 590628 R-Sq = 28.1% R-Sq(adj) = 25.8%

Analysis of Variance

Source	DF	SS	MS	F	P
Regression	2	8.19941E+12	4.09970E+12	11.75	0.000
Residual Error	60	2.09305E+13	3.48842E+11		
Total	62	2.91299E+13			

Source	DF	Seq SS
Two digi	1	6.98227E+12
Total_1	1	1.21714E+12

Unusual Observations

Obs	Two digi	EMRM	Fit	SE Fit	Residual	St Resid
11	1.00	41797	1974032	200229	-1932235	-3.48R
21	1.00	698013	2251546	101199	-1553533	-2.67R
34	2.00	3372169	2248582	206355	1123587	2.03R

Regression Analysis: EMRM versus Two digit year

The regression equation is

$$\text{EMRM} = 2065330 + 235108 \text{ Two digit year}$$

MAPE = 21.3%

Predictor	Coef	SE Coef	T	P
Constant	2065330	76717	26.92	0.000
Two digi	235108	53613	4.39	0.000

S = 602558 R-Sq = 24.0% R-Sq(adj) = 22.7%

Analysis of Variance

Source	DF	SS	MS	F	P
Regression	1	6.98227E+12	6.98227E+12	19.23	0.000
Residual Error	61	2.21477E+13	3.63076E+11		
Total	62	2.91299E+13			

Unusual Observations

Obs	Two digi	EMRM	Fit	SE Fit	Residual	St Resid
11	1.00	41797	2300438	99730	-2258641	-3.80R
21	1.00	698013	2300438	99730	-1602425	-2.70R
39	-2.00	338476	1595115	122517	-1256639	-2.13R

R denotes an observation with a large standardized residual

Pacific Fleet

Regression Analysis: EMRM versus UW not dep, UW Dep not 17, Code 17

The regression equation is

$$\text{EMRM} = 1341095 + 5605 \text{ UW not dep} + 8467 \text{ UW Dep not 17} + 4489 \text{ Code 17}$$

MAPE = 18.4%

Predictor	Coef	SE Coef	T	P
Constant	1341095	347084	3.86	0.000
UW not d	5605	3004	1.87	0.070
UW Dep n	8467	3616	2.34	0.024
Code 17	4489	2676	1.68	0.101

S = 573905 R-Sq = 17.9% R-Sq(adj) = 11.6%

Analysis of Variance

Source	DF	SS	MS	F	P
Regression	3	2.80101E+12	9.33671E+11	2.83	0.051
Residual Error	39	1.28453E+13	3.29366E+11		
Total	42	1.56463E+13			

Source	DF	Seq SS
UW not d	1	64849569939
UW Dep n	1	1.80961E+12
Code 17	1	9.26557E+11

Unusual Observations

Obs	UW not d	EMRM	Fit	SE Fit	Residual	St Resid
1	37	61000	1548486	249450	-1487486	-2.88R
12	203	1808200	2478942	323957	-670742	-1.42 X
18	0	2224800	2602689	331303	-377889	-0.81 X
21	115	3502600	2256745	141918	1245855	2.24R
30	62	1406700	2563098	159777	-1156398	-2.10R
31	38	929000	2272189	112031	-1343189	-2.39R

R denotes an observation with a large standardized residual

X denotes an observation whose X value gives it large influence.

Regression Analysis: EMRM versus UW not dep, Total UW Deployed

The regression equation is

$$\text{EMRM} = 1465298 + 4463 \text{ UW not dep} + 5898 \text{ Total UW Deployed}$$

MAPE = 22.1%

Predictor	Coef	SE Coef	T	P
Constant	1465298	316486	4.63	0.000
UW not d	4463	2704	1.65	0.107
Total UW	5898	2144	2.75	0.009

S = 572331 R-Sq = 16.3% R-Sq(adj) = 12.1%

Analysis of Variance

Source	DF	SS	MS	F	P
Regression	2	2.54379E+12	1.27189E+12	3.88	0.029
Residual Error	40	1.31025E+13	3.27563E+11		
Total	42	1.56463E+13			

Source	DF	Seq SS
UW not d	1	64849569939
Total UW	1	2.47894E+12

Unusual Observations

Obs	UW not d	EMRM	Fit	SE Fit	Residual	St Resid
1	37	61000	1630423	230944	-1569423	-3.00R
12	203	1808200	2371253	299342	-563053	-1.15 X
21	115	3502600	2214440	133235	1288160	2.31R
30	62	1406700	2514620	149653	-1107920	-2.01R
31	38	929000	2301349	106768	-1372349	-2.44R

R denotes an observation with a large standardized residual

X denotes an observation whose X value gives it large influence.

Regression Analysis: EMRM versus Total_1

The regression equation is

$$\text{EMRM} = 1398205 + 5716 \text{ Total}_1$$

MAPE = 33.9%

Predictor	Coef	SE Coef	T	P
Constant	1398205	302056	4.63	0.000
Total_1	5716	2119	2.70	0.010

S = 569296 R-Sq = 15.1% R-Sq(adj) = 13.0%

Analysis of Variance

Source	DF	SS	MS	F	P
Regression	1	2.35831E+12	2.35831E+12	7.28	0.010
Residual Error	41	1.32880E+13	3.24097E+11		
Total	42	1.56463E+13			

Unusual Observations

Obs	Total_1	EMRM	Fit	SE Fit	Residual	St Resid
1	37	61000	1609693	228079	-1548693	-2.97RX
21	155	3502600	2284168	95226	1218432	2.17R
31	151	929000	2261304	92069	-1332304	-2.37R

R denotes an observation with a large standardized residual

X denotes an observation whose X value gives it large influence.

CG-47 Class

SO

Combined

Regression Analysis: OTHER versus 2 digit year, Pac Flt, ...

The regression equation is

$$\text{OTHER} = 100447 + 41255 \text{ 2 digit year} + 190405 \text{ Pac Flt} + 3605 \text{ UW not dep} \\ + 3130 \text{ UW Dep not 17} + 2576 \text{ Code 17}$$

MAPE = 23.9%

Predictor	Coef	SE Coef	T	P
Constant	100447	45478	2.21	0.029
2 digit	41255	10311	4.00	0.000
Pac Flt	190405	28429	6.70	0.000
UW not d	3605.1	479.2	7.52	0.000
UW Dep n	3130.4	377.2	8.30	0.000
Code 17	2576.1	390.2	6.60	0.000

S = 158674 R-Sq = 61.0% R-Sq(adj) = 59.5%

Analysis of Variance

Source	DF	SS	MS	F	P
Regression	5	5.34730E+12	1.06946E+12	42.48	0.000
Residual Error	136	3.42414E+12	25177513142		
Total	141	8.77144E+12			

Source	DF	Seq SS
2 digit	1	7.46818E+11
Pac Flt	1	1.20302E+12
UW not d	1	2.59729E+11
UW Dep n	1	2.04017E+12
Code 17	1	1.09756E+12

Unusual Observations

Obs	2 digit	OTHER	Fit	SE Fit	Residual	St Resid
8	2.00	1172700	780733	35029	391967	2.53R
23	2.00	30000	373362	45585	-343362	-2.26R
52	2.00	1348200	832682	37557	515518	3.34R
56	1.00	428018	776730	29168	-348712	-2.24R
79	2.00	997738	1034670	61444	-36932	-0.25 X
100	2.00	775025	424495	28918	350530	2.25R
106	2.00	189952	507411	27770	-317459	-2.03R

R denotes an observation with a large standardized residual

X denotes an observation whose X value gives it large influence.

Regression Analysis: OTHER versus 2 digit year, Total_1

The regression equation is

$$\text{OTHER} = 212997 + 51850 \text{ 2 digit year} + 2984 \text{ Total}_1$$

MAPE = 24.3%

Predictor	Coef	SE Coef	T	P
Constant	212997	38099	5.59	0.000
2 digit	51850	11600	4.47	0.000
Total_1	2983.8	289.9	10.29	0.000

S = 181008 R-Sq = 48.1% R-Sq(adj) = 47.3%

Analysis of Variance

Source	DF	SS	MS	F	P
Regression	2	4.21727E+12	2.10864E+12	64.36	0.000
Residual Error	139	4.55417E+12	32763803341		
Total	141	8.77144E+12			

Source	DF	Seq SS
2 digit	1	7.46818E+11
Total_1	1	3.47045E+12

Unusual Observations

Obs	2 digit	OTHER	Fit	SE Fit	Residual	St Resid
1	-1.00	862000	480413	22367	381587	2.12R
8	2.00	1172700	653865	24228	518835	2.89R
52	2.00	1348200	785152	26156	563048	3.14R
56	1.00	428018	864590	28693	-436572	-2.44R
67	1.00	434479	834752	26395	-400273	-2.24R
79	2.00	997738	1155143	52046	-157405	-0.91 X
106	2.00	189952	585238	25802	-395286	-2.21R

R denotes an observation with a large standardized residual
X denotes an observation whose X value gives it large influence.

Regression Analysis: OTHER versus 2 digit year, Pac Flt, Total_1

The regression equation is

$$\text{OTHER} = 151319 + 40916 \text{ 2 digit year} + 177117 \text{ Pac Flt} + 2920 \text{ Total}_1$$

MAPE = 25.5

Predictor	Coef	SE Coef	T	P
Constant	151319	34880	4.34	0.000
2 digit	40916	10352	3.95	0.000
Pac Flt	177117	27531	6.43	0.000
Total_1	2919.8	255.4	11.43	0.000

S = 159334 R-Sq = 60.1% R-Sq(adj) = 59.2%

Analysis of Variance

Source	DF	SS	MS	F	P
Regression	3	5.26797E+12	1.75599E+12	69.17	0.000
Residual Error	138	3.50347E+12	25387430260		
Total	141	8.77144E+12			

Source	DF	Seq SS
2 digit	1	7.46818E+11
Pac Flt	1	1.20302E+12
Total_1	1	3.31813E+12

Unusual Observations

Obs	2 digit	OTHER	Fit	SE Fit	Residual	St Resid
8	2.00	1172700	740205	25198	432495	2.75R
15	-1.00	53400	375114	35522	-321714	-2.07R
19	1.00	59300	392710	36143	-333410	-2.15R
23	2.00	30000	410267	40355	-380267	-2.47R
52	2.00	1348200	868676	26432	479524	3.05R
56	1.00	428018	779114	28539	-351096	-2.24R
67	1.00	434479	749916	26716	-315437	-2.01R
79	2.00	997738	1053614	48457	-55876	-0.37 X
100	2.00	775025	428777	28848	346249	2.21R

R denotes an observation with a large standardized residual
 X denotes an observation whose X value gives it large influence.

Atlantic Fleet

The regression equation is

$$\text{OTHER} = 193428 + 49367 \text{ 2 digit year} + 3030 \text{ UW not dep} + 1906 \text{ UW Dep not 17} + 1663 \text{ Code 17}$$

MAPE = 21.7%

82 cases used 1 cases contain missing values

Predictor	Coef	SE Coef	T	P
Constant	193428	52976	3.65	0.000
2 digit	49367	10732	4.60	0.000
UW not d	3029.5	600.8	5.04	0.000
UW Dep n	1906.2	397.9	4.79	0.000
Code 17	1662.6	439.1	3.79	0.000

S = 134235 R-Sq = 49.4% R-Sq(adj) = 46.8%

Analysis of Variance

Source	DF	SS	MS	F	P
Regression	4	1.35709E+12	3.39272E+11	18.83	0.000
Residual Error	77	1.38746E+12	18018943361		
Total	81	2.74455E+12			

Source	DF	Seq SS
2 digit	1	4.79421E+11
UW not d	1	1.98520E+11
UW Dep n	1	4.20840E+11
Code 17	1	2.58307E+11

Unusual Observations

Obs	2 digit	OTHER	Fit	SE Fit	Residual	St Resid
9	1.00	428018	708085	29771	-280067	-2.14R
10	2.00	947631	664645	33036	282987	2.18R
16	2.00	1003701	734418	40679	269283	2.11R
20	2.00	997738	919818	67669	77920	0.67 X
21	2.00	775025	495143	29842	279883	2.14R
32	2.00	1067228	775254	49623	291974	2.34R
33	2.00	189952	564822	28771	-374870	-2.86R

R denotes an observation with a large standardized residual

X denotes an observation whose X value gives it large influence.

Regression Analysis: OTHER versus 2 digit year, Total_1

The regression equation is

$$\text{OTHER} = 246691 + 43832 \text{ 2 digit year} + 2107 \text{ Total}_1$$

MAPE 23.3%

Predictor	Coef	SE Coef	T	P
Constant	246691	37775	6.53	0.000
2 digit	43832	11117	3.94	0.000
Total_1	2106.9	292.3	7.21	0.000

S = 141064 R-Sq = 47.0% R-Sq(adj) = 45.6%

Analysis of Variance

Source	DF	SS	MS	F	P
Regression	2	1.41014E+12	7.05072E+11	35.43	0.000
Residual Error	80	1.59194E+12	19899191688		
Total	82	3.00208E+12			

Source	DF	Seq SS
2 digit	1	3.76083E+11
Total_1	1	1.03406E+12

Unusual Observations

Obs	2 digit	OTHER	Fit	SE Fit	Residual	St Resid
9	1.00	428018	714013	29696	-285995	-2.07R
10	2.00	947631	667247	27360	280384	2.03R
20	2.00	997738	926397	52925	71340	0.55 X
21	2.00	775025	475519	29893	299507	2.17R
32	2.00	1067228	778914	36277	288314	2.11R
33	2.00	189952	523977	26895	-334025	-2.41R
35	2.00	0	334355	43642	-334355	-2.49R

R denotes an observation with a large standardized residual

X denotes an observation whose X value gives it large influence.

Pacific Fleet

Regression Analysis: Other versus 2 digit year, UW not dep, ...

The regression equation is

$$\text{Other} = 126572 + 40860 \text{ 2 digit year} + 4890 \text{ UW not dep} + 5099 \text{ Uw Deployed Not 17} + 3320 \text{ Code 17}$$

MAPE = 20.8%

Predictor	Coef	SE Coef	T	P
Constant	126572	68919	1.84	0.072
2 digit	40860	18857	2.17	0.035
UW not d	4890.3	762.8	6.41	0.000
Uw Deplo	5099.2	697.7	7.31	0.000
Code 17	3320.1	620.6	5.35	0.000

S = 163427 R-Sq = 66.2% R-Sq(adj) = 63.7%

Analysis of Variance

Source	DF	SS	MS	F	P
Regression	4	2.82760E+12	7.06900E+11	26.47	0.000
Residual Error	54	1.44226E+12	26708426481		
Total	58	4.26986E+12			

Source	DF	Seq SS
2 digit	1	85295937688
UW not d	1	23911017304
Uw Deplo	1	1.95402E+12
Code 17	1	7.64378E+11

Unusual Observations

Obs	2 digit	Other	Fit	SE Fit	Residual	St Resid
12	2.00	1348200	905673	52507	442527	2.86R
36	2.00	1172700	760894	46679	411806	2.63R

R denotes an observation with a large standardized residual

Regression Analysis: Other versus 2 digit year, UW not dep, Total UW Dep

The regression equation is

$$\text{Other} = 166433 + 39827 \text{ 2 digit year} + 4378 \text{ UW not dep} + 4123 \text{ Total UW Deployed}$$

MAPE = 21.2%

Predictor	Coef	SE Coef	T	P
Constant	166433	66188	2.51	0.015
2 digit	39827	19192	2.08	0.043
UW not d	4378.5	716.7	6.11	0.000
Total UW	4123.2	422.5	9.76	0.000

S = 166413 R-Sq = 64.3% R-Sq(adj) = 62.4%

Analysis of Variance

Source	DF	SS	MS	F	P
Regression	3	2.74673E+12	9.15577E+11	33.06	0.000
Residual Error	55	1.52313E+12	27693189980		
Total	58	4.26986E+12			

Source	DF	Seq SS
2 digit	1	85295937688
UW not d	1	23911017304
Total UW	1	2.63752E+12

Unusual Observations

Obs	2 digit	Other	Fit	SE Fit	Residual	St Resid
12	2.00	1348200	893424	52983	454776	2.88R
36	2.00	1172700	740855	46062	431845	2.70R

R denotes an observation with a large standardized residual

Regression Analysis: Other versus 2 digit year, Total_1

The regression equation is

$$\text{Other} = 180099 + 40288 \text{ 2 digit year} + 4132 \text{ Total}_1$$

MAPE = 21.2%

Predictor	Coef	SE Coef	T	P
Constant	180099	57417	3.14	0.003
2 digit	40288	19020	2.12	0.039
Total_1	4132.4	418.8	9.87	0.000

S = 165190 R-Sq = 64.2% R-Sq(adj) = 62.9%

Analysis of Variance

Source	DF	SS	MS	F	P
Regression	2	2.74173E+12	1.37087E+12	50.24	0.000
Residual Error	56	1.52812E+12	27287889172		
Total	58	4.26986E+12			

Source	DF	Seq SS
2 digit	1	85295937688
Total_1	1	2.65644E+12

Unusual Observations

Obs	2 digit	Other	Fit	SE Fit	Residual	St Resid
12	2.00	1348200	909464	36890	438736	2.72R
36	2.00	1172700	727638	33713	445062	2.75R

R denotes an observation with a large standardized residual

SR

Combined

The regression equation is

$$\text{EMRM} = 400753 + 10018 \text{ UW not dep} + 7212 \text{ UW Dep not 17} + 7280 \text{ Code 17} \\ + 103074 \text{ two digit year}$$

MAPE = 26.5%

Predictor	Coef	SE Coef	T	P
Constant	400753	112247	3.57	0.000
UW not d	10018	1249	8.02	0.000
UW Dep n	7212	1002	7.20	0.000
Code 17	7280	1027	7.09	0.000
two digi	103074	27088	3.81	0.000

S = 421850 R-Sq = 51.4% R-Sq(adj) = 50.0%

Analysis of Variance

Source	DF	SS	MS	F	P
Regression	4	2.57757E+13	6.44392E+12	36.21	0.000
Residual Error	137	2.43802E+13	1.77958E+11		
Total	141	5.01559E+13			

Source	DF	Seq SS
UW not d	1	2.56278E+12
UW Dep n	1	1.12639E+13
Code 17	1	9.37240E+12
two digi	1	2.57664E+12

Unusual Observations

Obs	UW not d	EMRM	Fit	SE Fit	Residual	St Resid
7	68	2338300	1288095	67435	1050205	2.52R
28	0	2085600	1228027	118595	857573	2.12R
41	0	2177600	1218429	84325	959171	2.32R
79	114	2812633	2963370	156879	-150736	-0.38 X
100	67	2513652	1278077	67712	1235574	2.97R
101	97	2455176	1578604	69428	876572	2.11R
109	87	2196434	1272281	49063	924153	2.21R

R denotes an observation with a large standardized residual
 X denotes an observation whose X value gives it large influence.

Regression Analysis: EMRM versus two digit year, Total_1

The regression equation is

$$\text{EMRM} = 562075 + 99154 \text{ two digit year} + 7482 \text{ Total}_1$$

MAPE = 26.8

Predictor	Coef	SE Coef	T	P
Constant	562075	90138	6.24	0.000
two digi	99154	27445	3.61	0.000
Total_1	7482.4	685.9	10.91	0.000

S = 428246 R-Sq = 49.2% R-Sq(adj) = 48.4%

Analysis of Variance

Source	DF	SS	MS	F	P
Regression	2	2.46640E+13	1.23320E+13	67.24	0.000
Residual Error	139	2.54919E+13	1.83395E+11		
Total	141	5.01559E+13			

Source	DF	Seq SS
two digi	1	2.83999E+12
Total_1	1	2.18240E+13

Unusual Observations

Obs	two digi	EMRM	Fit	SE Fit	Residual	St Resid
7	2.00	2338300	1269190	67926	1069110	2.53R
34	2.00	2725200	1867785	59749	857415	2.02R
79	2.00	2812633	2862950	123137	-50317	-0.12 X
100	2.00	2513652	1261707	68301	1251944	2.96R
101	2.00	2455176	1486180	59495	968996	2.28R
109	0.00	2196434	1213047	43610	983387	2.31R

R denotes an observation with a large standardized residual
 X denotes an observation whose X value gives it large influence.

Atlantic Fleet

Regression Analysis: EMRM versus two digit year, UW not dep, ...

The regression equation is

$$\text{EMRM} = 429539 + 113649 \text{ two digit year} + 10825 \text{ UW not dep} + 3968 \text{ UW Dep not 17} + 6475 \text{ Code 17}$$

MAPE = 24.5%

81 cases used 2 cases contain missing values

Predictor	Coef	SE Coef	T	P
Constant	429539	165818	2.59	0.011
two digi	113649	31154	3.65	0.000
UW not d	10825	1866	5.80	0.000
UW Dep n	3968	1170	3.39	0.001
Code 17	6475	1276	5.08	0.000

S = 388425 R-Sq = 49.3% R-Sq(adj) = 46.6%

Analysis of Variance

Source	DF	SS	MS	F	P
Regression	4	1.11298E+13	2.78245E+12	18.44	0.000
Residual Error	76	1.14665E+13	1.50874E+11		
Total	80	2.25963E+13			

Source	DF	Seq SS
two digi	1	2.77103E+12
UW not d	1	2.76147E+12
UW Dep n	1	1.70996E+12
Code 17	1	3.88734E+12

Unusual Observations

Obs	two digi	EMRM	Fit	SE Fit	Residual	St Resid
20	2.00	2812633	2924579	198015	-111946	-0.34 X
21	2.00	2513652	1382141	89317	1131511	2.99R
36	0.00	2196434	1371351	56693	825083	2.15R
60	1.00	447032	1236015	73983	-788983	-2.07R

R denotes an observation with a large standardized residual
 X denotes an observation whose X value gives it large influence.

Regression Analysis: EMRM versus two digit ye, UW not dep, Total UW dep

The regression equation is

$$\text{EMRM} = 392123 + 112791 \text{ two digit year} + 11212 \text{ UW not dep} + 5113 \text{ Total UW deployed}$$

MAPE = 24.6 %

81 cases used 2 cases contain missing values

Predictor	Coef	SE Coef	T	P
Constant	392123	164976	2.38	0.020
two digi	112791	31371	3.60	0.001
UW not d	11212	1860	6.03	0.000
Total UW	5113.0	870.5	5.87	0.000

S = 391208 R-Sq = 47.8% R-Sq(adj) = 45.8%

Analysis of Variance

Source	DF	SS	MS	F	P
Regression	3	1.08119E+13	3.60397E+12	23.55	0.000
Residual Error	77	1.17844E+13	1.53044E+11		
Total	80	2.25963E+13			

Source	DF	Seq SS
two digi	1	2.77103E+12
UW not d	1	2.76147E+12
Total UW	1	5.27939E+12

Unusual Observations

Obs	two digi	EMRM	Fit	SE Fit	Residual	St Resid
20	2.00	2812633	2749725	158290	62908	0.18 X
21	2.00	2513652	1368897	89487	1144755	3.01R
36	0.00	2196434	1367551	57039	828883	2.14R
60	1.00	447032	1222470	73918	-775438	-2.02R

R denotes an observation with a large standardized residual
 X denotes an observation whose X value gives it large influence.

Regression Analysis: EMRM versus two digit year, Total_1

The regression equation is

$$\text{EMRM} = 674755 + 92003 \text{ two digit year} + 6475 \text{ Total}_1$$

MAPE = 27.2%

Predictor	Coef	SE Coef	T	P
Constant	674755	117046	5.76	0.000
two digi	92003	34445	2.67	0.009
Total_1	6474.8	905.6	7.15	0.000

S = 437092 R-Sq = 43.1% R-Sq(adj) = 41.7%

Analysis of Variance

Source	DF	SS	MS	F	P
Regression	2	1.15668E+13	5.78339E+12	30.27	0.000
Residual Error	80	1.52839E+13	1.91049E+11		
Total	82	2.68507E+13			

Source	DF	Seq SS
two digi	1	1.80086E+12
Total_1	1	9.76592E+12

Unusual Observations

Obs	two digi	EMRM	Fit	SE Fit	Residual	St Resid
20	2.00	2812633	2678194	163990	134439	0.33 X
21	2.00	2513652	1292576	92624	1221075	2.86R
23	2.00	2455176	1486822	81359	968354	2.25R
35	2.00	0	858761	135227	-858761	-2.07R
36	0.00	2196434	1238067	55865	958367	2.21R

R denotes an observation with a large standardized residual
 X denotes an observation whose X value gives it large influence.

Pacific Fleet

Regression Analysis: EMRM versus UW not dep, Uw Deployed Not 17, ...

The regression equation is

$$\text{EMRM} = 248942 + 10652 \text{ UW not dep} + 11890 \text{ Uw Deployed Not 17} + 6623 \text{ Code 17} + 120507 \text{ Two digit Year}$$

MAPE = 23.9%

Predictor	Coef	SE Coef	T	P
Constant	248942	170772	1.46	0.151
UW not d	10652	1890	5.64	0.000
Uw Deplo	11890	1729	6.88	0.000
Code 17	6623	1538	4.31	0.000
Two digi	120507	46724	2.58	0.013

S = 404950 R-Sq = 61.5% R-Sq(adj) = 58.6%

Analysis of Variance

Source	DF	SS	MS	F	P
Regression	4	1.41281E+13	3.53203E+12	21.54	0.000
Residual Error	54	8.85514E+12	1.63984E+11		
Total	58	2.29833E+13			

Source	DF	Seq SS
UW not d	1	72609260679
Uw Deplo	1	9.93164E+12
Code 17	1	3.03307E+12
Two digi	1	1.09081E+12

Unusual Observations

Obs	UW not d	EMRM	Fit	SE Fit	Residual	St Resid
10	0	2177600	1381796	104431	795804	2.03R
32	68	2338300	1214273	99209	1124027	2.86R
42	58	1116000	2031938	139987	-915938	-2.41R

R denotes an observation with a large standardized residual

Regression Analysis: EMRM versus UW not dep, Total UW Dep, Two digit Year

The regression equation is

$$\text{EMRM} = 366956 + 9136 \text{ UW not dep} + 9000 \text{ Total UW Deployed} + 117450 \text{ Two digit Year}$$

MAPE = 25.2%

Predictor	Coef	SE Coef	T	P
Constant	366956	165857	2.21	0.031
UW not d	9136	1796	5.09	0.000
Total UW	9000	1059	8.50	0.000
Two digi	117450	48091	2.44	0.018

S = 417002 R-Sq = 58.4% R-Sq(adj) = 56.1%

Analysis of Variance

Source	DF	SS	MS	F	P
Regression	3	1.34193E+13	4.47309E+12	25.72	0.000
Residual Error	55	9.56400E+12	1.73891E+11		
Total	58	2.29833E+13			

Source	DF	Seq SS
UW not d	1	72609260679
Total UW	1	1.23095E+13
Two digi	1	1.03719E+12

Unusual Observations

Obs	UW not d	EMRM	Fit	SE Fit	Residual	St Resid
32	68	2338300	1223134	102068	1115166	2.76R

R denotes an observation with a large standardized residual

Regression Analysis: EMRM versus Total_1, Two digit Year

The regression equation is

$$\text{EMRM} = 374250 + 9005 \text{ Total}_1 + 117696 \text{ Two digit Year}$$

MAPE = 25.3 %

Predictor	Coef	SE Coef	T	P
Constant	374250	143653	2.61	0.012
Total_1	9005	1048	8.59	0.000
Two digi	117696	47587	2.47	0.016

S = 413293 R-Sq = 58.4% R-Sq(adj) = 56.9%

Analysis of Variance

Source	DF	SS	MS	F	P
Regression	2	1.34179E+13	6.70893E+12	39.28	0.000
Residual Error	56	9.56542E+12	1.70811E+11		
Total	58	2.29833E+13			

Source	DF	Seq SS
Total_1	1	1.23730E+13
Two digi	1	1.04488E+12

Unusual Observations

Obs	Total_1	EMRM	Fit	SE Fit	Residual	St Resid
32	68	2338300	1221989	100380	1116311	2.78R

R denotes an observation with a large standardized residual

FFG Class

SO

Combined

Regression Analysis: OTHER versus two digit year, Pac Flt, ...

The regression equation is

$$\text{OTHER} = 253249 + 57776 \text{ two digit year} + 298451 \text{ Pac Flt} + 1936 \text{ UW not dep} + 1010 \text{ UW Dep not 17} + 1602 \text{ Code 17}$$

MAPE = 19.8%

123 cases used 3 cases contain missing values

Predictor	Coef	SE Coef	T	P
Constant	253249	48824	5.19	0.000
two digi	57776	11261	5.13	0.000
Pac Flt	298451	32310	9.24	0.000
UW not d	1936.1	427.2	4.53	0.000
UW Dep n	1010.3	471.5	2.14	0.034
Code 17	1602.5	524.4	3.06	0.003

S = 160149 R-Sq = 60.8% R-Sq(adj) = 59.1%

Analysis of Variance

Source	DF	SS	MS	F	P
Regression	5	4.64516E+12	9.29033E+11	36.22	0.000
Residual Error	117	3.00079E+12	25647759218		
Total	122	7.64595E+12			

Source	DF	Seq SS
two digi	1	1.61569E+12
Pac Flt	1	2.43825E+12
UW not d	1	2.63868E+11
UW Dep n	1	87836177153
Code 17	1	2.39525E+11

Unusual Observations

Obs	two digi	OTHER	Fit	SE Fit	Residual	St Resid
7	2.00	1132400	816334	36230	316066	2.03R
26	2.00	1106818	497093	35167	609725	3.90R
43	1.00	1338200	968024	46382	370176	2.41R
74	2.00	95200	814761	53352	-719561	-4.77R

R denotes an observation with a large standardized residual

Regression Analysis: OTHER versus two digit year, Pac Flt, Total_1

The regression equation is

$$\text{OTHER} = 284174 + 57251 \text{ two digit year} + 283864 \text{ Pac Flt} + 1494 \text{ Total}_1$$

MAPE = 19.8%

123 cases used 3 cases contain missing values

Predictor	Coef	SE Coef	T	P
Constant	284174	45732	6.21	0.000
two digi	57251	11341	5.05	0.000
Pac Flt	283864	31912	8.90	0.000
Total_1	1493.7	355.0	4.21	0.000

S = 162101 R-Sq = 59.1% R-Sq(adj) = 58.1%

Analysis of Variance

Source	DF	SS	MS	F	P
Regression	3	4.51903E+12	1.50634E+12	57.33	0.000
Residual Error	119	3.12692E+12	26276654417		
Total	122	7.64595E+12			

Source	DF	Seq SS
two digi	1	1.61569E+12
Pac Flt	1	2.43825E+12
Total_1	1	4.65095E+11

Unusual Observations

Obs	two digi	OTHER	Fit	SE Fit	Residual	St Resid
5	1.00	1159000	837394	25348	321606	2.01R
7	2.00	1132400	797555	35641	334845	2.12R
15	1.00	1205600	883698	29045	321902	2.02R
26	2.00	1106818	506223	35198	600595	3.80R
43	1.00	1338200	958383	40969	379817	2.42R
74	2.00	95200	900620	30176	-805420	-5.06R
83	2.00	1004538	657086	36536	347452	2.20R

R denotes an observation with a large standardized residual

Regression Analysis: OTHER versus two digit year, Pac Flt

The regression equation is

OTHER = 460315 + 57856 two digit year + 303944 Pac Flt

MAPE = 19.2%

123 cases used 3 cases contain missing values

Predictor	Coef	SE Coef	T	P
Constant	460315	19639	23.44	0.000
two digi	57856	12103	4.78	0.000
Pac Flt	303944	33677	9.03	0.000

S = 173013 R-Sq = 53.0% R-Sq(adj) = 52.2%

Analysis of Variance

Source	DF	SS	MS	F	P
Regression	2	4.05394E+12	2.02697E+12	67.72	0.000
Residual Error	120	3.59202E+12	29933476392		
Total	122	7.64595E+12			

Source	DF	Seq SS
two digi	1	1.61569E+12
Pac Flt	1	2.43825E+12

Unusual Observations

Obs	two digi	OTHER	Fit	SE Fit	Residual	St Resid
15	1.00	1205600	822114	26776	383486	2.24R
26	2.00	1106818	576026	33132	530792	3.13R
43	1.00	1338200	822114	26776	516086	3.02R
74	2.00	95200	879970	31779	-784770	-4.61R
83	2.00	1004538	576026	33132	428512	2.52R

R denotes an observation with a large standardized residual

Atlantic Fleet

Regression Analysis: OTHER versus 2 digit year

The regression equation is

OTHER = 465728 + 63906 2 digit year

MAPE = 17.7%

Predictor	Coef	SE Coef	T	P
Constant	465728	13856	33.61	0.000
2 digit	63906	9768	6.54	0.000

S = 124907 R-Sq = 34.9% R-Sq(adj) = 34.0%

Analysis of Variance

Source	DF	SS	MS	F	P
Regression	1	6.67840E+11	6.67840E+11	42.81	0.000
Residual Error	80	1.24813E+12	15601657346		
Total	81	1.91597E+12			

Unusual Observations

Obs	2 digit	OTHER	Fit	SE Fit	Residual	St Resid
7	2.00	1106818	593541	24996	513277	4.19R
17	2.00	895746	593541	24996	302205	2.47R
39	2.00	1004538	593541	24996	410997	3.36R
61	-1.00	75753	401821	16180	-326068	-2.63R
75	-2.00	14169	337915	22857	-323746	-2.64R

R denotes an observation with a large standardized residual

Regression Analysis: OTHER versus 2 digit year, Total_1

The regression equation is

$$\text{OTHER} = 395351 + 64795 \text{ 2 digit year} + 603 \text{ Total}_1$$

MAPE = 17.4%

Predictor	Coef	SE Coef	T	P
Constant	395351	38961	10.15	0.000
2 digit	64795	9617	6.74	0.000
Total_1	603.3	312.9	1.93	0.057

S = 122838 R-Sq = 37.8% R-Sq(adj) = 36.2%

Analysis of Variance

Source	DF	SS	MS	F	P
Regression	2	7.23935E+11	3.61968E+11	23.99	0.000
Residual Error	79	1.19204E+12	15089072538		
Total	81	1.91597E+12			

Source	DF	Seq SS
2 digit	1	6.67840E+11
Total_1	1	56095857129

Unusual Observations

Obs	2 digit	OTHER	Fit	SE Fit	Residual	St Resid
7	2.00	1106818	568381	27831	538437	4.50R
17	2.00	895746	613029	26579	282717	2.36R
32	2.00	765101	529767	41210	235334	2.03RX
39	2.00	1004538	629319	30800	375219	3.16R
61	-1.00	75753	370377	22785	-294624	-2.44R
75	-2.00	14169	265762	43653	-251593	-2.19RX

R denotes an observation with a large standardized residual

X denotes an observation whose X value gives it large influence.

Pacific Fleet

Regression Analysis: OTHER versus 2 digit year, Total_1

The regression equation is

OTHER = 399035 + 46848 2 digit year + 2818 Total_1

MAPE = 19.2%

Predictor	Coef	SE Coef	T	P
Constant	399035	105911	3.77	0.001
2 digit	46848	28361	1.65	0.106
Total_1	2817.8	768.7	3.67	0.001

S = 209756 R-Sq = 29.5% R-Sq(adj) = 26.1%

Analysis of Variance

Source	DF	SS	MS	F	P
Regression	2	7.54654E+11	3.77327E+11	8.58	0.001
Residual Error	41	1.80390E+12	43997530668		
Total	43	2.55855E+12			

Source	DF	Seq SS
2 digit	1	1.63407E+11
Total_1	1	5.91247E+11

Unusual Observations

Obs	2 digit	OTHER	Fit	SE Fit	Residual	St Resid
7	2.00	1132400	709698	69512	422702	2.14R
43	2.00	95200	904124	53509	-808924	-3.99R

R denotes an observation with a large standardized residual

Regression Analysis: OTHER versus Total_1

The regression equation is

OTHER = 410151 + 2911 Total_1

MAPE = 20.0%

Predictor	Coef	SE Coef	T	P
Constant	410151	107851	3.80	0.000
Total_1	2911.3	782.2	3.72	0.001

S = 214029 R-Sq = 24.8% R-Sq(adj) = 23.0%

Analysis of Variance

Source	DF	SS	MS	F	P
Regression	1	6.34599E+11	6.34599E+11	13.85	0.001
Residual Error	42	1.92395E+12	45808439945		
Total	43	2.55855E+12			

Unusual Observations

Obs	Total_1	OTHER	Fit	SE Fit	Residual	St Resid
7	77	1132400	634322	53506	498078	2.40R
43	146	95200	835202	34184	-740002	-3.50R

R denotes an observation with a large standardized residual

Regression Analysis: OTHER versus UW not dep, UW Dep, Code 17

The regression equation is

$$\text{OTHER} = 367734 + 3749 \text{ UW not dep} + 2382 \text{ UW Dep} + 3003 \text{ Code 17}$$

MAPE = 20.5%

Predictor	Coef	SE Coef	T	P
Constant	367734	119646	3.07	0.004
UW not d	3749	1035	3.62	0.001
UW Dep	2382	1077	2.21	0.033
Code 17	3003.3	985.1	3.05	0.004

S = 210464 R-Sq = 30.7% R-Sq(adj) = 25.6%

Analysis of Variance

Source	DF	SS	MS	F	P
Regression	3	7.86747E+11	2.62249E+11	5.92	0.002
Residual Error	40	1.77181E+12	44295161101		
Total	43	2.55855E+12			

Source	DF	Seq SS
UW not d	1	2.31568E+11
UW Dep	1	1.43446E+11
Code 17	1	4.11732E+11

Unusual Observations

Obs	UW not d	OTHER	Fit	SE Fit	Residual	St Resid
7	77	1132400	656392	54883	476008	2.34R
43	0	95200	715476	89090	-620276	-3.25R

R denotes an observation with a large standardized residual

SR

Combined

Regression Analysis: EMRM versus two digit ye, UW not dep, Total UW Dep

The regression equation is

$$\text{EMRM} = 1114799 + 117170 \text{ two digit year} + 3286 \text{ UW not dep} + 1569 \text{ Total UW Deployd}$$

MAPE = 17.5%

123 cases used 3 cases contain missing values

Predictor	Coef	SE Coef	T	P
Constant	1114799	97485	11.44	0.000
two digi	117170	22146	5.29	0.000
UW not d	3286.1	866.2	3.79	0.000
Total UW	1568.9	734.1	2.14	0.035

S = 326899 R-Sq = 26.7% R-Sq(adj) = 24.8%

Analysis of Variance

Source	DF	SS	MS	F	P
Regression	3	4.62560E+12	1.54187E+12	14.43	0.000
Residual Error	119	1.27167E+13	1.06863E+11		
Total	122	1.73423E+13			

Source	DF	Seq SS
two digi	1	3.07395E+12
UW not d	1	1.06349E+12
Total UW	1	4.88156E+11

Unusual Observations

Obs	two digi	EMRM	Fit	SE Fit	Residual	St Resid
7	2.00	2405900	1602166	63208	803734	2.51R
50	2.00	2510504	1737895	54472	772609	2.40R
78	2.00	2590602	1490440	79329	1100162	3.47R
97	1.00	2419458	1774171	68271	645287	2.02R
105	-1.00	127519	1214510	54004	-1086991	-3.37R
119	-2.00	7051	880460	106052	-873409	-2.82RX

R denotes an observation with a large standardized residual
X denotes an observation whose X value gives it large influence.

Regression Analysis: EMRM versus two digit year, Pac Flt, ...

The regression equation is

$$\text{EMRM} = 1183994 + 140115 \text{ two digit year} - 264124 \text{ Pac Flt} + 3278 \text{ UW not dep} + 2182 \text{ Total UW Deployd}$$

MAPE = 16.1%

123 cases used 3 cases contain missing values

Predictor	Coef	SE Coef	T	P
Constant	1183994	92480	12.80	0.000
two digi	140115	21367	6.56	0.000
Pac Flt	-264124	61603	-4.29	0.000
UW not d	3277.9	809.1	4.05	0.000
Total UW	2182.5	700.5	3.12	0.002

S = 305357 R-Sq = 36.6% R-Sq(adj) = 34.4%

Analysis of Variance

Source	DF	SS	MS	F	P
Regression	4	6.33967E+12	1.58492E+12	17.00	0.000
Residual Error	118	1.10026E+13	93242757262		
Total	122	1.73423E+13			

Source	DF	Seq SS
two digi	1	3.07395E+12
Pac Flt	1	1.68126E+12
UW not d	1	6.79240E+11
Total UW	1	9.05211E+11

Unusual Observations

Obs	two digi	EMRM	Fit	SE Fit	Residual	St Resid
7	2.00	2405900	1452502	68590	953398	3.20R
50	2.00	2510504	1884744	61336	625760	2.09R
78	2.00	2590602	1605176	78785	985426	3.34R
105	-1.00	127519	1260223	51560	-1132704	-3.76R
119	-2.00	7051	903764	99212	-896713	-3.11R

R denotes an observation with a large standardized residual

Atlantic Fleet

Regression Analysis: EMRM versus 2 digit year, UW not dep, Total UW dep

The regression equation is

EMRM = 1199609 + 189197 2 digit year + 3498 UW not dep + 1826 Total UW dep

MAPE = 15.6%

Predictor	Coef	SE Coef	T	P
Constant	1199609	109044	11.00	0.000
2 digit	189197	25311	7.47	0.000
UW not d	3498	1003	3.49	0.001
Total UW	1826.3	907.4	2.01	0.048

S = 322929 R-Sq = 45.5% R-Sq(adj) = 43.4%

Analysis of Variance

Source	DF	SS	MS	F	P
Regression	3	6.77920E+12	2.25973E+12	21.67	0.000
Residual Error	78	8.13409E+12	1.04283E+11		
Total	81	1.49133E+13			

Source	DF	Seq SS
2 digit	1	5.50084E+12
UW not d	1	8.55877E+11
Total UW	1	4.22478E+11

Unusual Observations

Obs	2 digit	EMRM	Fit	SE Fit	Residual	St Resid
33	2.00	2907909	1812350	75258	1095559	3.49R
34	2.00	2590602	1728405	87555	862197	2.77R
61	-1.00	127519	1241263	59904	-1113744	-3.51R
75	-2.00	7051	821216	121477	-814165	-2.72R

R denotes an observation with a large standardized residual

MTB > regr c7 2 c5 c17 c20 c21

Regression Analysis: EMRM versus 2 digit year, Total_1

The regression equation is

EMRM = 1265013 + 187084 2 digit year + 2496 Total_1

MAPE = 15.6%

Predictor	Coef	SE Coef	T	P
Constant	1265013	103748	12.19	0.000
2 digit	187084	25609	7.31	0.000
Total_1	2495.6	833.3	2.99	0.004

S = 327103 R-Sq = 43.3% R-Sq(adj) = 41.9%

Analysis of Variance

Source	DF	SS	MS	F	P
Regression	2	6.46055E+12	3.23028E+12	30.19	0.000
Residual Error	79	8.45274E+12	1.06997E+11		
Total	81	1.49133E+13			

Source	DF	Seq SS
2 digit	1	5.50084E+12
Total_1	1	9.59710E+11

Unusual Observations

Obs	2 digit	EMRM	Fit	SE Fit	Residual	St Resid
31	2.00	1377377	2045960	77283	-668583	-2.10R
32	2.00	1694969	1659146	109738	35823	0.12 X
33	2.00	2907909	1806385	76153	1101524	3.46R
34	2.00	2590602	1746491	88066	844111	2.68R
61	-1.00	127519	1242637	60673	-1115118	-3.47R
75	-2.00	7051	890845	116245	-883794	-2.89RX

R denotes an observation with a large standardized residual
 X denotes an observation whose X value gives it large influence.

Regression Analysis: EMRM versus 2 digit year

The regression equation is
 EMRM = 1556107 + 183410 2 digit year
 MAPE =15.9%

Predictor	Coef	SE Coef	T	P
Constant	1556107	38050	40.90	0.000
2 digit	183410	26823	6.84	0.000

S = 343010 R-Sq = 36.9% R-Sq(adj) = 36.1%

Analysis of Variance

Source	DF	SS	MS	F	P
Regression	1	5.50084E+12	5.50084E+12	46.75	0.000
Residual Error	80	9.41245E+12	1.17656E+11		
Total	81	1.49133E+13			

Unusual Observations

Obs	2 digit	EMRM	Fit	SE Fit	Residual	St Resid
33	2.00	2907909	1922927	68643	984982	2.93R
53	1.00	2419458	1739517	48583	679941	2.00R
61	-1.00	127519	1372697	44432	-1245178	-3.66R
75	-2.00	7051	1189287	62767	-1182236	-3.51R

R denotes an observation with a large standardized residual

Pacific Fleet

No regressions were significant.

LHA Class

SO

Combined

Regression Analysis: OTHER versus Pac Flt

The regression equation is

OTHER = 1830385 + 1146365 Pac Flt

MAPE = 18.0%

Predictor	Coef	SE Coef	T	P
Constant	1830385	173896	10.53	0.000
Pac Flt	1146365	235456	4.87	0.000

S = 549908 R-Sq = 54.2% R-Sq(adj) = 51.9%

Analysis of Variance

Source	DF	SS	MS	F	P
Regression	1	7.16811E+12	7.16811E+12	23.70	0.000
Residual Error	20	6.04797E+12	3.02398E+11		
Total	21	1.32161E+13			

Unusual Observations

Obs	Pac Flt	OTHER	Fit	SE Fit	Residual	St Resid
1	0.00	2892981	1830385	173896	1062596	2.04R

R denotes an observation with a large standardized residual

Atlantic Fleet

Regression Analysis: OTHER versus two digit year

The regression equation is

OTHER = 1830385 + 218112 two digit year

MAPE = 18.3%

Predictor	Coef	SE Coef	T	P
Constant	1830385	147517	12.41	0.000
two digi	218112	104310	2.09	0.070

S = 466489 R-Sq = 35.3% R-Sq(adj) = 27.3%

Analysis of Variance

Source	DF	SS	MS	F	P
Regression	1	9.51461E+11	9.51461E+11	4.37	0.070
Residual Error	8	1.74090E+12	2.17612E+11		
Total	9	2.69236E+12			

Pacific Fleet

There were no significant regressions.

SR

Combined

There were no significant regressions.

Atlantic Fleet

Regression Analysis: EMRM versus two digit year

The regression equation is

EMRM = 2495823 + 467231 two digit year

MAPE = 24.2%

Predictor	Coef	SE Coef	T	P
Constant	2495823	303496	8.22	0.000
two digi	467231	214604	2.18	0.061

S = 959737 R-Sq = 37.2% R-Sq(adj) = 29.4%

Analysis of Variance

Source	DF	SS	MS	F	P
Regression	1	4.36610E+12	4.36610E+12	4.74	0.061
Residual Error	8	7.36876E+12	9.21095E+11		
Total	9	1.17349E+13			

Unusual Observations

Obs	two digi	EMRM	Fit	SE Fit	Residual	St Resid
2	2.00	5526726	3430286	525670	2096440	2.61R

R denotes an observation with a large standardized residual

Pacific Fleet

There were no significant regressions.

LHD Class

SO

Combined

Regression Analysis: OTHER versus Pac Flt, Total UW

The regression equation is

$$\text{OTHER} = 1060138 + 591557 \text{ Pac Flt} + 4965 \text{ Total UW}$$

MAPE = 21.1%

Predictor	Coef	SE Coef	T	P
Constant	1060138	294293	3.60	0.001
Pac Flt	591557	248919	2.38	0.025
Total UW	4965	2171	2.29	0.031

S = 650219 R-Sq = 33.6% R-Sq(adj) = 28.5%

Analysis of Variance

Source	DF	SS	MS	F	P
Regression	2	5.56270E+12	2.78135E+12	6.58	0.005
Residual Error	26	1.09924E+13	4.22785E+11		
Total	28	1.65551E+13			

Source	DF	Seq SS
Pac Flt	1	3.35079E+12
Total UW	1	2.21191E+12

Unusual Observations

Obs	Pac Flt	OTHER	Fit	SE Fit	Residual	St Resid
21	1.00	56800	2446073	195796	-2389273	-3.85R

R denotes an observation with a large standardized residual

Regression Analysis: OTHER versus Total UW

The regression equation is

$$\text{OTHER} = 1195299 + 5858 \text{ Total UW}$$

MAPE = 26.3%

Predictor	Coef	SE Coef	T	P
Constant	1195299	312611	3.82	0.001
Total UW	5858	2315	2.53	0.018

S = 703962 R-Sq = 19.2% R-Sq(adj) = 16.2%

Analysis of Variance

Source	DF	SS	MS	F	P
Regression	1	3.17491E+12	3.17491E+12	6.41	0.018
Residual Error	27	1.33802E+13	4.95563E+11		
Total	28	1.65551E+13			

Unusual Observations

Obs	Total UW	OTHER	Fit	SE Fit	Residual	St Resid
21	160	56800	2132635	156670	-2075835	-3.02R
25	63	2995200	1564375	190196	1430825	2.11R

R denotes an observation with a large standardized residual

Atlantic Fleet

Regression Analysis: OTHER versus Total UW

The regression equation is

$$\text{OTHER} = 1109434 + 4534 \text{ Total UW}$$

MAPE = 17.6%

Predictor	Coef	SE Coef	T	P
Constant	1109434	205519	5.40	0.000
Total UW	4534	1600	2.83	0.013

S = 384443 R-Sq = 34.9% R-Sq(adj) = 30.5%

Analysis of Variance

Source	DF	SS	MS	F	P
Regression	1	1.18697E+12	1.18697E+12	8.03	0.013
Residual Error	15	2.21694E+12	1.47796E+11		
Total	16	3.40391E+12			

Unusual Observations

Obs	Total UW	OTHER	Fit	SE Fit	Residual	St Resid
2	44	2098745	1308940	146311	789805	2.22R
11	31	370431	1249995	162880	-879564	-2.53R

R denotes an observation with a large standardized residual

Pacific Fleet

There were no significant regressions.

SR

Combined

Regression Analysis: EMRM versus 2 digit year, UW not dep, Total Dep UW

The regression equation is

$$\text{EMRM} = 1156393 + 124175 \text{ 2 digit year} + 9707 \text{ UW not dep} + 7426 \text{ Total Dep UW}$$

MAPE = 15.3

Predictor	Coef	SE Coef	T	P
Constant	1156393	254629	4.54	0.000
2 digit	124175	64670	1.92	0.066
UW not d	9707	3016	3.22	0.004
Total De	7426	1479	5.02	0.000

S = 442904 R-Sq = 57.3% R-Sq(adj) = 52.2%

Analysis of Variance

Source	DF	SS	MS	F	P
Regression	3	6.59329E+12	2.19776E+12	11.20	0.000
Residual Error	25	4.90410E+12	1.96164E+11		
Total	28	1.14974E+13			

Source	DF	Seq SS
2 digit	1	1.35444E+12
UW not d	1	2.96171E+11
Total De	1	4.94268E+12

Unusual Observations

Obs	2 digit	EMRM	Fit	SE Fit	Residual	St Resid
1	2.00	3999581	3140435	179414	859146	2.12R
11	1.00	604176	1581494	182401	-977318	-2.42R

R denotes an observation with a large standardized residual

Regression Analysis: EMRM versus 2 digit year, Total UW

The regression equation is

$$\text{EMRM} = 1290522 + 113189 \text{ 2 digit year} + 7522 \text{ Total UW}$$

MAPE = 15.4%

Predictor	Coef	SE Coef	T	P
Constant	1290522	195709	6.59	0.000
2 digit	113189	62925	1.80	0.084
Total UW	7522	1466	5.13	0.000

S = 440256 R-Sq = 56.2% R-Sq(adj) = 52.8%

Analysis of Variance

Source	DF	SS	MS	F	P
Regression	2	6.45793E+12	3.22897E+12	16.66	0.000
Residual Error	26	5.03946E+12	1.93826E+11		
Total	28	1.14974E+13			

Source	DF	Seq SS
2 digit	1	1.35444E+12
Total UW	1	5.10349E+12

Unusual Observations

Obs	2 digit	EMRM	Fit	SE Fit	Residual	St Resid
1	2.00	3999581	3134164	178184	865417	2.15R
4	2.00	3071911	2186372	148619	885539	2.14R
11	1.00	604176	1636898	168754	-1032722	-2.54R

R denotes an observation with a large standardized residual

Regression Analysis: EMRM versus UW not dep, UW Dep not 17, Code 17

The regression equation is

$$\text{EMRM} = 1025405 + 11963 \text{ UW not dep} + 4940 \text{ UW Dep not 17} + 11242 \text{ Code 17}$$

MAPE 14.8%

Predictor	Coef	SE Coef	T	P
Constant	1025405	259353	3.95	0.001
UW not d	11963	3185	3.76	0.001
UW Dep n	4940	1933	2.56	0.017
Code 17	11242	2045	5.50	0.000

S = 432053 R-Sq = 59.4% R-Sq(adj) = 54.5%

Analysis of Variance

Source	DF	SS	MS	F	P
Regression	3	6.83065E+12	2.27688E+12	12.20	0.000
Residual Error	25	4.66675E+12	1.86670E+11		
Total	28	1.14974E+13			

Source	DF	Seq SS
UW not d	1	94479522260
UW Dep n	1	1.09253E+12
Code 17	1	5.64363E+12

Unusual Observations

Obs	UW not d	EMRM	Fit	SE Fit	Residual	St Resid
4	89	3071911	2090130	122465	981781	2.37R
11	31	604176	1396265	175567	-792089	-2.01R

R denotes an observation with a large standardized residual

Atlantic Fleet

Regression Analysis: EMRM versus UW not dep, UW Dep not 17, Code 17

The regression equation is

$$\text{EMRM} = 785076 + 16559 \text{ UW not dep} + 4675 \text{ UW Dep not 17} + 13331 \text{ Code 17}$$

MAPE = 12.6%

Predictor	Coef	SE Coef	T	P
Constant	785076	288202	2.72	0.017
UW not d	16559	3543	4.67	0.000
UW Dep n	4675	2271	2.06	0.060
Code 17	13331	2496	5.34	0.000

S = 403864 R-Sq = 75.6% R-Sq(adj) = 69.9%

Analysis of Variance

Source	DF	SS	MS	F	P
Regression	3	6.55764E+12	2.18588E+12	13.40	0.000
Residual Error	13	2.12038E+12	1.63106E+11		
Total	16	8.67802E+12			

Source	DF	Seq SS
UW not d	1	1.32441E+12
UW Dep n	1	5.80655E+11
Code 17	1	4.65257E+12

Unusual Observations

Obs	UW not d	EMRM	Fit	SE Fit	Residual	St Resid
4	89	3071911	2258840	139357	813071	2.14R
14	129	2231250	2921206	235797	-689956	-2.10R

R denotes an observation with a large standardized residual

Regression Analysis: EMRM versus UW not dep, Total Dep UW

The regression equation is

$$\text{EMRM} = 827705 + 15099 \text{ UW not dep} + 8581 \text{ Total Dep UW}$$

MAPE = 15.8%

Predictor	Coef	SE Coef	T	P
Constant	827705	342197	2.42	0.030
UW not d	15099	4161	3.63	0.003
Total De	8581	2029	4.23	0.001

S = 480301 R-Sq = 62.8% R-Sq(adj) = 57.5%

Analysis of Variance

Source	DF	SS	MS	F	P
Regression	2	5.44837E+12	2.72418E+12	11.81	0.001
Residual Error	14	3.22965E+12	2.30689E+11		
Total	16	8.67802E+12			

Source	DF	Seq SS
UW not d	1	1.32441E+12
Total De	1	4.12396E+12

Unusual Observations

Obs	UW not d	EMRM	Fit	SE Fit	Residual	St Resid
1	61	3999581	3070140	239310	929441	2.23R

R denotes an observation with a large standardized residual

Regression Analysis: EMRM versus Total UW

The regression equation is

$$\text{EMRM} = 1196309 + 9152 \text{ Total UW}$$

MAPE = 17.8%

Predictor	Coef	SE Coef	T	P
Constant	1196309	270560	4.42	0.000
Total UW	9152	2106	4.35	0.001

S = 506108 R-Sq = 55.7% R-Sq(adj) = 52.8%

Analysis of Variance

Source	DF	SS	MS	F	P
Regression	1	4.83584E+12	4.83584E+12	18.88	0.001
Residual Error	15	3.84217E+12	2.56145E+11		
Total	16	8.67802E+12			

Unusual Observations

Obs	Total UW	EMRM	Fit	SE Fit	Residual	St Resid
4	89	3071911	2010843	133961	1061068	2.17R

R denotes an observation with a large standardized residual

Pacific Fleet

Regression Analysis: EMRM versus 2 digit year, Total UW

The regression equation is

$$\text{EMRM} = 1395677 + 186636 \text{ 2 digit year} + 5703 \text{ Total UW}$$

MAPE = 11.5%

Predictor	Coef	SE Coef	T	P
Constant	1395677	268750	5.19	0.001
2 digit	186636	87529	2.13	0.062
Total UW	5703	1895	3.01	0.015

S = 334043 R-Sq = 64.4% R-Sq(adj) = 56.5%

Analysis of Variance

Source	DF	SS	MS	F	P
Regression	2	1.81425E+12	9.07125E+11	8.13	0.010
Residual Error	9	1.00426E+12	1.11585E+11		
Total	11	2.81851E+12			

Source	DF	Seq SS
2 digit	1	8.03861E+11
Total UW	1	1.01039E+12

Regression Analysis: EMRM versus 2 digit year

The regression equation is
 EMRM = 2139293 + 231497 2 digit year
 MAPE =15.8%

Predictor	Coef	SE Coef	T	P
Constant	2139293	141939	15.07	0.000
2 digit	231497	115892	2.00	0.074

S = 448849 R-Sq = 28.5% R-Sq(adj) = 21.4%

Analysis of Variance

Source	DF	SS	MS	F	P
Regression	1	8.03861E+11	8.03861E+11	3.99	0.074
Residual Error	10	2.01465E+12	2.01465E+11		
Total	11	2.81851E+12			

Regression Analysis: EMRM versus Total UW

The regression equation is
 EMRM = 1396541 + 6391 Total UW
 MAPE = 13.1%

Predictor	Coef	SE Coef	T	P
Constant	1396541	312798	4.46	0.001
Total UW	6391	2173	2.94	0.015

S = 388794 R-Sq = 46.4% R-Sq(adj) = 41.0%

Analysis of Variance

Source	DF	SS	MS	F	P
Regression	1	1.30691E+12	1.30691E+12	8.65	0.015
Residual Error	10	1.51160E+12	1.51160E+11		
Total	11	2.81851E+12			

LPD Class

SO

Combined

Regression Analysis: Other versus Two digit year, Pac Flt, Total_1

The regression equation is

Other = 459942 + 47618 Two digit year + 493034 Pac Flt + 2381 Total_1

MAPE = 15.7%

Predictor	Coef	SE Coef	T	P
Constant	459942	89188	5.16	0.000
Two digi	47618	23530	2.02	0.049
Pac Flt	493034	61268	8.05	0.000
Total_1	2381.4	637.7	3.73	0.001

S = 210176 R-Sq = 66.8% R-Sq(adj) = 64.6%

Analysis of Variance

Source	DF	SS	MS	F	P
Regression	3	3.99960E+12	1.33320E+12	30.18	0.000
Residual Error	45	1.98783E+12	44174018866		
Total	48	5.98743E+12			

Source	DF	Seq SS
Two digi	1	6.39653E+11
Pac Flt	1	2.74385E+12
Total_1	1	6.16102E+11

Unusual Observations

Obs	Two digi	Other	Fit	SE Fit	Residual	St Resid
3	0.00	675000	1122054	53948	-447054	-2.20R
14	0.00	793800	1210166	45019	-416366	-2.03R
17	0.00	1763800	1286370	46477	477430	2.33R
23	-1.00	1918900	1353059	71665	565841	2.86R

R denotes an observation with a large standardized residual

Atlantic Fleet

Regression Analysis: Other versus Two digit year

The regression equation is

Other = 753710 + 49124 Two digit year

MAPE = 10.3%

Predictor	Coef	SE Coef	T	P
Constant	753710	21502	35.05	0.000
Two digi	49124	15204	3.23	0.004

S = 107509 R-Sq = 31.2% R-Sq(adj) = 28.2%

Analysis of Variance

Source	DF	SS	MS	F	P
Regression	1	1.20657E+11	1.20657E+11	10.44	0.004
Residual Error	23	2.65840E+11	11558256384		
Total	24	3.86497E+11			

Pacific Fleet

Regression Analysis: Other versus Total_1

The regression equation is

$$\text{Other} = 691450 + 4762 \text{ Total}_1$$

MAPE = 15.0%

Predictor	Coef	SE Coef	T	P
Constant	691450	142414	4.86	0.000
Total_1	4762	1112	4.28	0.000

S = 245729 R-Sq = 45.5% R-Sq(adj) = 43.0%

Analysis of Variance

Source	DF	SS	MS	F	P
Regression	1	1.10701E+12	1.10701E+12	18.33	0.000
Residual Error	22	1.32842E+12	60382945961		
Total	23	2.43544E+12			

Regression Analysis: Other versus UW not dep, Uw Deployed not , Code 17

The regression equation is

$$\text{Other} = 629996 + 5102 \text{ UW not dep} + 6866 \text{ Uw Deployed not } 17 + 3522 \text{ Code } 17$$

MAPE = 14.4%

Predictor	Coef	SE Coef	T	P
Constant	629996	222707	2.83	0.010
UW not d	5102	2748	1.86	0.078
Uw Deplo	6866	2074	3.31	0.003
Code 17	3522	1456	2.42	0.025

S = 243255 R-Sq = 51.4% R-Sq(adj) = 44.1%

Analysis of Variance

Source	DF	SS	MS	F	P
Regression	3	1.25198E+12	4.17325E+11	7.05	0.002
Residual Error	20	1.18346E+12	59173053252		
Total	23	2.43544E+12			

Source	DF	Seq SS
UW not d	1	89187985964
Uw Deplo	1	8.16632E+11
Code 17	1	3.46156E+11

Unusual Observations

Obs	UW not d	Other	Fit	SE Fit	Residual	St Resid
4	66	1449200	966731	81280	482469	2.10R

R denotes an observation with a large standardized residual

SR

Combined

Regression Analysis: EMRM versus Two digit ye, UW not dep, Total Deploy

The regression equation is

EMRM = 588844 + 87060 Two digit year + 3051 UW not dep + 1639 Total Deployed

MAPE = 17.8%

Predictor	Coef	SE Coef	T	P
Constant	588844	110552	5.33	0.000
Two digi	87060	22265	3.91	0.000
UW not d	3051	1323	2.31	0.026
Total De	1638.8	618.7	2.65	0.011

S = 202703 R-Sq = 34.8% R-Sq(adj) = 30.5%

Analysis of Variance

Source	DF	SS	MS	F	P
Regression	3	9.87893E+11	3.29298E+11	8.01	0.000
Residual Error	45	1.84897E+12	41088313672		
Total	48	2.83687E+12			

Source	DF	Seq SS
Two digi	1	6.60225E+11
UW not d	1	39366552211
Total De	1	2.88301E+11

Unusual Observations

Obs	Two digi	EMRM	Fit	SE Fit	Residual	St Resid
26	2.00	671000	1129292	58450	-458292	-2.36R
44	2.00	1350195	961278	60790	388917	2.01R

R denotes an observation with a large standardized residual

Regression Analysis: EMRM versus Two digit year, Total_1

The regression equation is

EMRM = 686844 + 86693 Two digit year + 1544 Total_1

MAPE = 18.2%

Predictor	Coef	SE Coef	T	P
Constant	686844	80665	8.51	0.000
Two digi	86693	22421	3.87	0.000
Total_1	1544.4	618.7	2.50	0.016

S = 204139 R-Sq = 32.4% R-Sq(adj) = 29.5%

Analysis of Variance

Source	DF	SS	MS	F	P
Regression	2	9.19929E+11	4.59965E+11	11.04	0.000
Residual Error	46	1.91694E+12	41672556508		
Total	48	2.83687E+12			

Source	DF	Seq SS
Two digi	1	6.60225E+11
Total_1	1	2.59704E+11

Unusual Observations

Obs	Two digi	EMRM	Fit	SE Fit	Residual	St Resid
26	2.00	671000	1133595	58768	-462595	-2.37R
44	2.00	1350195	960618	61219	389577	2.00R

R denotes an observation with a large standardized residual

Regression Analysis: EMRM versus Two digit year

The regression equation is

EMRM = 874094 + 89155 Two digit year

MAPE = 20.0%

Predictor	Coef	SE Coef	T	P
Constant	874094	31282	27.94	0.000
Two digi	89155	23613	3.78	0.000

S = 215201 R-Sq = 23.3% R-Sq(adj) = 21.6%

Analysis of Variance

Source	DF	SS	MS	F	P
Regression	1	6.60225E+11	6.60225E+11	14.26	0.000
Residual Error	47	2.17664E+12	46311525078		
Total	48	2.83687E+12			

Atlantic Fleet

Regression Analysis: EMRM versus Two digit year

The regression equation is

EMRM = 858139 + 76908 Two digit year

MAPE = 16.8%

Predictor	Coef	SE Coef	T	P
Constant	858139	36630	23.43	0.000
Two digi	76908	25901	2.97	0.007

S = 183148 R-Sq = 27.7% R-Sq(adj) = 24.6%

Analysis of Variance

Source	DF	SS	MS	F	P
Regression	1	2.95739E+11	2.95739E+11	8.82	0.007
Residual Error	23	7.71493E+11	33543160441		
Total	24	1.06723E+12			

Unusual Observations

Obs	Two digi	EMRM	Fit	SE Fit	Residual	St Resid
9	2.00	1442333	1011954	63444	430379	2.50R

R denotes an observation with a large standardized residual

Pacific Fleet

Regression Analysis: EMRM versus Two digit ye, UW not dep, Total Deploy

The regression equation is

EMRM = 515894 + 95973 Two digit year + 3626 UW not dep + 2633 Total Deployed

MAPE = 18.3%

Predictor	Coef	SE Coef	T	P
Constant	515894	166540	3.10	0.006
Two digi	95973	41594	2.31	0.032
UW not d	3626	2013	1.80	0.087
Total De	2633	1033	2.55	0.019

S = 227321 R-Sq = 39.1% R-Sq(adj) = 30.0%

Analysis of Variance

Source	DF	SS	MS	F	P
Regression	3	6.63247E+11	2.21082E+11	4.28	0.017
Residual Error	20	1.03350E+12	51675001346		
Total	23	1.69675E+12			

Source	DF	Seq SS
Two digi	1	3.17776E+11
UW not d	1	9795094743
Total De	1	3.35676E+11

Unusual Observations

Obs	Two digi	EMRM	Fit	SE Fit	Residual	St Resid
24	2.00	671000	1227427	95296	-556427	-2.70R

R denotes an observation with a large standardized residual

Regression Analysis: EMRM versus Two digit year, Total_1

The regression equation is

$$\text{EMRM} = 576194 + 96696 \text{ Two digit year} + 2593 \text{ Total}_1$$

MAPE = 18.5%

Predictor	Coef	SE Coef	T	P
Constant	576194	130384	4.42	0.000
Two digi	96696	40935	2.36	0.028
Total_1	2593	1015	2.56	0.018

S = 223812 R-Sq = 38.0% R-Sq(adj) = 32.1%

Analysis of Variance

Source	DF	SS	MS	F	P
Regression	2	6.44822E+11	3.22411E+11	6.44	0.007
Residual Error	21	1.05192E+12	50091659519		
Total	23	1.69675E+12			

Source	DF	Seq SS
Two digi	1	3.17776E+11
Total_1	1	3.27047E+11

Unusual Observations

Obs	Two digi	EMRM	Fit	SE Fit	Residual	St Resid
24	2.00	671000	1228580	93805	-557580	-2.74R

R denotes an observation with a large standardized residual

Regression Analysis: EMRM versus Two digit year

The regression equation is
 EMRM = 883832 + 102920 Two digit year
 MAPE = 22.6%

Predictor	Coef	SE Coef	T	P
Constant	883832	55982	15.79	0.000
Two digi	102920	45709	2.25	0.035

S = 250361 R-Sq = 18.7% R-Sq(adj) = 15.0%

Analysis of Variance

Source	DF	SS	MS	F	P
Regression	1	3.17776E+11	3.17776E+11	5.07	0.035
Residual Error	22	1.37897E+12	62680518470		
Total	23	1.69675E+12			

LSD-36 Class

SO

Combined

Regression Analysis: OTHER versus 2 digit year, Pac Flt

The regression equation is
 OTHER = 659230 + 175118 2 digit year + 400311 Pac Flt
 MAPE = 27.9%

Predictor	Coef	SE Coef	T	P
Constant	659230	119727	5.51	0.000
2 digit	175118	63354	2.76	0.017
Pac Flt	400311	170164	2.35	0.037

S = 308515 R-Sq = 62.6% R-Sq(adj) = 56.3%

Analysis of Variance

Source	DF	SS	MS	F	P
Regression	2	1.91025E+12	9.55124E+11	10.03	0.003
Residual Error	12	1.14217E+12	95181226526		
Total	14	3.05242E+12			

Source	DF	Seq SS
2 digit	1	1.38349E+12
Pac Flt	1	5.26760E+11

Unusual Observations

Obs	2 digit	OTHER	Fit	SE Fit	Residual	St Resid
11	2.00	2017900	1409777	144667	608123	2.23R

R denotes an observation with a large standardized residual

Regression Analysis: OTHER versus Pac Flt

The regression equation is

$$\text{OTHER} = 584179 + 562921 \text{ Pac Flt}$$

MAPE = 29.8%

Predictor	Coef	SE Coef	T	P
Constant	584179	143328	4.08	0.001
Pac Flt	562921	196260	2.87	0.013

S = 379210 R-Sq = 38.8% R-Sq(adj) = 34.0%

Analysis of Variance

Source	DF	SS	MS	F	P
Regression	1	1.18302E+12	1.18302E+12	8.23	0.013
Residual Error	13	1.86940E+12	1.43800E+11		
Total	14	3.05242E+12			

Unusual Observations

Obs	Pac Flt	OTHER	Fit	SE Fit	Residual	St Resid
11	1.00	2017900	1147100	134071	870800	2.45R

R denotes an observation with a large standardized residual

Regression Analysis: OTHER versus 2 digit year

The regression equation is

$$\text{OTHER} = 869294 + 226643 \text{ 2 digit year}$$

MAPE = 27.5

Predictor	Coef	SE Coef	T	P
Constant	869294	92627	9.38	0.000
2 digit	226643	69040	3.28	0.006

S = 358301 R-Sq = 45.3% R-Sq(adj) = 41.1%

Analysis of Variance

Source	DF	SS	MS	F	P
Regression	1	1.38349E+12	1.38349E+12	10.78	0.006
Residual Error	13	1.66893E+12	1.28380E+11		
Total	14	3.05242E+12			

Unusual Observations

Obs	2 digit	OTHER	Fit	SE Fit	Residual	St Resid
11	2.00	2017900	1322581	162404	695319	2.18R

R denotes an observation with a large standardized residual

Atlantic Fleet

No regressions were significant.

Pacific Fleet

Regression Analysis: OTHER versus Total_1

The regression equation is

OTHER = - 176656 + 10929 Total_1

MAPE = 22.6%

Predictor	Coef	SE Coef	T	P
Constant	-176656	601007	-0.29	0.779
Total_1	10929	4850	2.25	0.065

S = 358491 R-Sq = 45.8% R-Sq(adj) = 36.8%

Analysis of Variance

Source	DF	SS	MS	F	P
Regression	1	6.52484E+11	6.52484E+11	5.08	0.065
Residual Error	6	7.71093E+11	1.28515E+11		
Total	7	1.42358E+12			

Unusual Observations

Obs	Total_1	OTHER	Fit	SE Fit	Residual	St Resid
4	139	2017900	1342453	153561	675447	2.09R

R denotes an observation with a large standardized residual

Regression Analysis: OTHER versus 2 digit year

The regression equation is

OTHER = 1018790 + 256620 2 digit year

MAPE 21.2%

Predictor	Coef	SE Coef	T	P
Constant	1018790	138297	7.37	0.000
2 digit	256620	112919	2.27	0.063

S = 357080 R-Sq = 46.3% R-Sq(adj) = 37.3%

Analysis of Variance

Source	DF	SS	MS	F	P
Regression	1	6.58538E+11	6.58538E+11	5.16	0.063
Residual Error	6	7.65038E+11	1.27506E+11		
Total	7	1.42358E+12			

SR

Combined

Regression Analysis: EMRM versus 2 digit year

The regression equation is

EMRM = 809213 + 116406 2 digit year

MAPE = 18.3%

Predictor	Coef	SE Coef	T	P
Constant	809213	50370	16.07	0.000
2 digit	116406	37543	3.10	0.008

S = 194840 R-Sq = 42.5% R-Sq(adj) = 38.1%

Analysis of Variance

Source	DF	SS	MS	F	P
Regression	1	3.64955E+11	3.64955E+11	9.61	0.008
Residual Error	13	4.93512E+11	37962485129		
Total	14	8.58468E+11			

Unusual Observations

Obs	2 digit	EMRM	Fit	SE Fit	Residual	St Resid
7	-2.00	995290	576401	92471	418889	2.44R

Atlantic Fleet

No regressions were significant

Pacific Fleet

Regression Analysis: EMRM versus 2 digit year, UW not dep, ...

The regression equation is

$$\text{EMRM} = 132031 + 210208 \text{ 2 digit year} + 6168 \text{ UW not dep} + 3274 \text{ UW Dep} + 3783 \text{ Code 17}$$

MAPE = 3.3%

Predictor	Coef	SE Coef	T	P
Constant	132031	124632	1.06	0.367
2 digit	210208	18569	11.32	0.001
UW not d	6168	1441	4.28	0.023
UW Dep	3274.0	914.9	3.58	0.037
Code 17	3783.0	920.1	4.11	0.026

S = 55299 R-Sq = 98.6% R-Sq(adj) = 96.7%

Analysis of Variance

Source	DF	SS	MS	F	P
Regression	4	6.36016E+11	1.59004E+11	52.00	0.004
Residual Error	3	9174014535	3058004845		
Total	7	6.45190E+11			

Source	DF	Seq SS
2 digit	1	5.63754E+11
UW not d	1	11426544621
UW Dep	1	9144550373
Code 17	1	51690806971

Regression Analysis: EMRM versus 2 digit year, UW not dep, Total Dep UW

The regression equation is

$$\text{EMRM} = 132195 + 210146 \text{ 2 digit year} + 6100 \text{ UW not dep} + 3526 \text{ Total Dep UW}$$

MAPE = 2.8%

Predictor	Coef	SE Coef	T	P
Constant	132195	113424	1.17	0.309
2 digit	210146	16899	12.44	0.000
UW not d	6100	1306	4.67	0.010
Total De	3525.5	725.1	4.86	0.008

S = 50326 R-Sq = 98.4% R-Sq(adj) = 97.3%

Analysis of Variance

Source	DF	SS	MS	F	P
Regression	3	6.35059E+11	2.11686E+11	83.58	0.000
Residual Error	4	10130978444	2532744611		
Total	7	6.45190E+11			

Source	DF	Seq SS
2 digit	1	5.63754E+11
UW not d	1	11426544621
Total De	1	59878393435

Regression Analysis: EMRM versus 2 digit year, Total_1

The regression equation is

$$\text{EMRM} = 313960 + 210862 \text{ 2 digit year} + 3385 \text{ Total}_1$$

MAPE = 4.9%

Predictor	Coef	SE Coef	T	P
Constant	313960	124325	2.53	0.053
2 digit	210862	24162	8.73	0.000
Total_1	3385	1034	3.27	0.022

S = 71970 R-Sq = 96.0% R-Sq(adj) = 94.4%

Analysis of Variance

Source	DF	SS	MS	F	P
Regression	2	6.19291E+11	3.09646E+11	59.78	0.000
Residual Error	5	25898323838	5179664768		
Total	7	6.45190E+11			

Source	DF	Seq SS
2 digit	1	5.63754E+11
Total_1	1	55537592662

Regression Analysis: EMRM versus 2 digit year

The regression equation is

$$\text{EMRM} = 710695 + 237435 \text{ 2 digit year}$$

MAPE = 10.6%

Predictor	Coef	SE Coef	T	P
Constant	710695	45121	15.75	0.000
2 digit	237435	36841	6.44	0.001

S = 116502 R-Sq = 87.4% R-Sq(adj) = 85.3%

Analysis of Variance

Source	DF	SS	MS	F	P
Regression	1	5.63754E+11	5.63754E+11	41.54	0.001
Residual Error	6	81435916500	13572652750		
Total	7	6.45190E+11			

LSD-41 Class

SO

Combined

Regression Analysis: OTHER versus Two digit year, Pac Flt

The regression equation is

$$\text{OTHER} = 574808 + 51171 \text{ Two digit year} + 412390 \text{ Pac Flt}$$

MAPE 22.5

Predictor	Coef	SE Coef	T	P
Constant	574808	42180	13.63	0.000
Two digi	51171	24494	2.09	0.042
Pac Flt	412390	64163	6.43	0.000

S = 226966 R-Sq = 51.9% R-Sq(adj) = 50.0%

Analysis of Variance

Source	DF	SS	MS	F	P
Regression	2	2.78461E+12	1.39231E+12	27.03	0.000
Residual Error	50	2.57567E+12	51513385293		
Total	52	5.36028E+12			

Source	DF	Seq SS
Two digi	1	6.56663E+11
Pac Flt	1	2.12795E+12

Unusual Observations

Obs	Two digi	OTHER	Fit	SE Fit	Residual	St Resid
3	0.00	514500	987198	47921	-472698	-2.13R
7	1.00	1659100	1038369	47921	620731	2.80R
8	-1.00	1445200	936026	59129	509174	2.32R
24	2.00	1187798	677151	65913	510647	2.35R

R denotes an observation with a large standardized residual

Regression Analysis: OTHER versus Two digit year, Pac Flt, Total_1

The regression equation is

$$\text{OTHER} = 384471 + 46986 \text{ Two digit year} + 370971 \text{ Pac Flt} + 1803 \text{ Total}_1$$

MAPE =20.5%

Predictor	Coef	SE Coef	T	P
Constant	384471	86833	4.43	0.000
Two digi	46986	23391	2.01	0.050
Pac Flt	370971	63368	5.85	0.000
Total_1	1802.9	729.2	2.47	0.017

S = 216180 R-Sq = 57.3% R-Sq(adj) = 54.7%

Analysis of Variance

Source	DF	SS	MS	F	P
Regression	3	3.07033E+12	1.02344E+12	21.90	0.000
Residual Error	49	2.28996E+12	46733813537		
Total	52	5.36028E+12			

Source	DF	Seq SS
Two digi	1	6.56663E+11
Pac Flt	1	2.12795E+12
Total_1	1	2.85712E+11

Unusual Observations

Obs	Two digi	OTHER	Fit	SE Fit	Residual	St Resid
7	1.00	1659100	1045817	45743	613283	2.90R
8	-1.00	1445200	957253	56970	487947	2.34R
16	2.00	970347	550558	81011	419789	2.09R
24	2.00	1187798	656928	63311	530870	2.57R
42	2.00	767141	885894	105208	-118753	-0.63 X

R denotes an observation with a large standardized residual
 X denotes an observation whose X value gives it large influence.

Atlantic Fleet

Regression Analysis: OTHER versus Two digit year

The regression equation is
 OTHER = 577158 + 85242 Two digit year
 MAPE 24.8

Predictor	Coef	SE Coef	T	P
Constant	577158	24767	23.30	0.000
Two digi	85242	17823	4.78	0.000

S = 133208 R-Sq = 45.9% R-Sq(adj) = 43.9%

Analysis of Variance

Source	DF	SS	MS	F	P
Regression	1	4.05902E+11	4.05902E+11	22.87	0.000
Residual Error	27	4.79100E+11	17744441035		
Total	28	8.85002E+11			

Unusual Observations

Obs	Two digi	OTHER	Fit	SE Fit	Residual	St Resid
9	2.00	1187798	747641	44403	440157	3.50R

Pacific Fleet

Regression Analysis: OTHER versus Total_1

The regression equation is
 OTHER = 513888 + 3846 Total_1
 MAPE= 19.0%

Predictor	Coef	SE Coef	T	P
Constant	513888	164717	3.12	0.005
Total_1	3846	1210	3.18	0.004

S = 244284 R-Sq = 31.5% R-Sq(adj) = 28.3%

Analysis of Variance

Source	DF	SS	MS	F	P
Regression	1	6.02658E+11	6.02658E+11	10.10	0.004
Residual Error	22	1.31284E+12	59674525174		
Total	23	1.91550E+12			

Unusual Observations

Obs	Total_1	OTHER	Fit	SE Fit	Residual	St Resid
7	135	1659100	1033137	50274	625963	2.62R
24	230	1158200	1398533	131228	-240333	-1.17 X

SR

Combined

Regression Analysis: EMRM versus Two digit year, Pac Flt

The regression equation is

$$\text{EMRM} = 987132 + 110765 \text{ Two digit year} - 158856 \text{ Pac Flt}$$

MAPE = 26.5%

Predictor	Coef	SE Coef	T	P
Constant	987132	34713	28.44	0.000
Two digi	110765	20158	5.49	0.000
Pac Flt	-158856	52804	-3.01	0.004

S = 186783 R-Sq = 40.2% R-Sq(adj) = 37.8%

Analysis of Variance

Source	DF	SS	MS	F	P
Regression	2	1.17404E+12	5.87019E+11	16.83	0.000
Residual Error	50	1.74440E+12	34887917028		
Total	52	2.91843E+12			

Source	DF	Seq SS
Two digi	1	8.58282E+11
Pac Flt	1	3.15757E+11

Unusual Observations

Obs	Two digi	EMRM	Fit	SE Fit	Residual	St Resid
5	2.00	1528000	1049806	48661	478194	2.65R
16	2.00	1635732	1208662	54243	427070	2.39R
36	-1.00	1114400	717511	48661	396889	2.20R

R denotes an observation with a large standardized residual

Atlantic Fleet

Regression Analysis: EMRM versus Two digit year

The regression equation is

EMRM = 988392 + 129041 Two digit year

MAPE = 22.6%

Predictor	Coef	SE Coef	T	P
Constant	988392	30321	32.60	0.000
Two digi	129041	21819	5.91	0.000

S = 163080 R-Sq = 56.4% R-Sq(adj) = 54.8%

Analysis of Variance

Source	DF	SS	MS	F	P
Regression	1	9.30194E+11	9.30194E+11	34.98	0.000
Residual Error	27	7.18067E+11	26595090169		
Total	28	1.64826E+12			

Unusual Observations

Obs	Two digi	EMRM	Fit	SE Fit	Residual	St Resid
1	2.00	1635732	1246474	54360	389258	2.53R
22	2.00	1555162	1246474	54360	308688	2.01R

R denotes an observation with a large standardized residual

Pacific Fleet

Regression Analysis: EMRM versus Two digit year

The regression equation is

EMRM = 881305 - 56488 Two digit year

MAPE= 17.0%

Predictor	Coef	SE Coef	T	P
Constant	881305	43393	20.31	0.000
Two digi	-56488	30369	-1.86	0.076

S = 212490 R-Sq = 13.6% R-Sq(adj) = 9.7%

Analysis of Variance

Source	DF	SS	MS	F	P
Regression	1	1.56219E+11	1.56219E+11	3.46	0.076
Residual Error	22	9.93346E+11	45152089188		
Total	23	1.14956E+12			

Unusual Observations

Obs	Two digi	EMRM	Fit	SE Fit	Residual	St Resid
5	-2.00	1528000	994280	73609	533720	2.68R

R denotes an observation with a large standardized residual

MCM Class

SO

Combined

Regression Analysis: OTHER versus two digit year, Total_1

The regression equation is

OTHER = 191822 + 22134 two digit year + 604 Total_1

MAPE = 13.4%

Predictor	Coef	SE Coef	T	P
Constant	191822	13944	13.76	0.000
two digi	22134	4099	5.40	0.000
Total_1	603.8	152.4	3.96	0.000

S = 39426 R-Sq = 54.0% R-Sq(adj) = 51.9%

Analysis of Variance

Source	DF	SS	MS	F	P
Regression	2	82032106705	41016053353	26.39	0.000
Residual Error	45	69949299274	1554428873		
Total	47	1.51981E+11			

Source	DF	Seq SS
two digi	1	57629871415
Total_1	1	24402235290

Unusual Observations

Obs	two digi	OTHER	Fit	SE Fit	Residual	St Resid
39	2.00	405708	314588	11658	91120	2.42R

R denotes an observation with a large standardized residual

Atlantic Fleet

Regression Analysis: OTHER versus two digit year

The regression equation is

OTHER = 216334 + 23261 two digit year

MAPE = 9.5%

Predictor	Coef	SE Coef	T	P
Constant	216334	5658	38.23	0.000
two digi	23261	4037	5.76	0.000

S = 29853 R-Sq = 56.1% R-Sq(adj) = 54.4%

Analysis of Variance

Source	DF	SS	MS	F	P
Regression	1	29584591743	29584591743	33.20	0.000
Residual Error	26	23171829827	891224224		
Total	27	52756421570			

Unusual Observations

Obs	two digi	OTHER	Fit	SE Fit	Residual	St Resid
3	2.00	326224	262855	10208	63369	2.26R
4	2.00	341543	262855	10208	78688	2.80R

R denotes an observation with a large standardized residual

Japan

Regression Analysis: OTHER versus two digit year

The regression equation is

$$\text{OTHER} = 270038 + 29781 \text{ two digit year}$$

MAPE = 8.9%

Predictor	Coef	SE Coef	T	P
Constant	270038	12042	22.42	0.000
two digi	29781	8515	3.50	0.008

S = 38081 R-Sq = 60.5% R-Sq(adj) = 55.5%

Analysis of Variance

Source	DF	SS	MS	F	P
Regression	1	17737801850	17737801850	12.23	0.008
Residual Error	8	11601287715	1450160964		
Total	9	29339089565			

Unusual Observations

Obs	two digi	OTHER	Fit	SE Fit	Residual	St Resid
1	2.00	405708	329599	20858	76109	2.39R

R denotes an observation with a large standardized residual

Regression Analysis: OTHER versus Total_1

The regression equation is

$$\text{OTHER} = 173739 + 1187 \text{ Total}_1$$

MAPE = 11.3%

Predictor	Coef	SE Coef	T	P
Constant	173739	33477	5.19	0.001
Total_1	1187.4	381.1	3.12	0.014

S = 40702 R-Sq = 54.8% R-Sq(adj) = 49.2%

Analysis of Variance

Source	DF	SS	MS	F	P
Regression	1	16085718653	16085718653	9.71	0.014
Residual Error	8	13253370912	1656671364		
Total	9	29339089565			

Unusual Observations						
Obs	Total_1	OTHER	Fit	SE Fit	Residual	St Resid
1	130	405708	328102	22647	77606	2.29R

Bahrain

Regression Analysis: OTHER versus two digit year

The regression equation is
 OTHER = 286603 + 19472 two digit year
 MAPE = 9.7%

Predictor	Coef	SE Coef	T	P
Constant	286603	12463	23.00	0.000
two digi	19472	8813	2.21	0.058

S = 39412 R-Sq = 37.9% R-Sq(adj) = 30.1%

Analysis of Variance

Source	DF	SS	MS	F	P
Regression	1	7583526180	7583526180	4.88	0.058
Residual Error	8	12426743306	1553342913		
Total	9	20010269486			

Unusual Observations						
Obs	two digi	OTHER	Fit	SE Fit	Residual	St Resid
2	2.00	394456	325547	21587	68909	2.09R

R denotes an observation with a large standardized residual

SR

Combined

Regression Analysis: EMRM versus two digit year, Total_1

The regression equation is
 EMRM = 792553 + 125855 two digit year + 2878 Total_1
 MAPE = 19.9%

Predictor	Coef	SE Coef	T	P
Constant	792553	97868	8.10	0.000
two digi	125855	28768	4.37	0.000
Total_1	2878	1070	2.69	0.010

S = 276726 R-Sq = 40.6% R-Sq(adj) = 38.0%

Analysis of Variance

Source	DF	SS	MS	F	P
Regression	2	2.35657E+12	1.17829E+12	15.39	0.000
Residual Error	45	3.44599E+12	76577515857		
Total	47	5.80256E+12			

Source	DF	Seq SS
two digi	1	1.80216E+12
Total_1	1	5.54413E+11

Unusual Observations

Obs	two digi	EMRM	Fit	SE Fit	Residual	St Resid
12	1.00	1800408	1188955	50525	611453	2.25R
38	-2.00	1995090	912127	89127	1082963	4.13R

R denotes an observation with a large standardized residual

Regression Analysis: EMRM versus two digit year

The regression equation is

EMRM = 1032911 + 137868 two digit year

MAPE = 22.7%

Predictor	Coef	SE Coef	T	P
Constant	1032911	42607	24.24	0.000
two digi	137868	30286	4.55	0.000

S = 294899 R-Sq = 31.1% R-Sq(adj) = 29.6%

Analysis of Variance

Source	DF	SS	MS	F	P
Regression	1	1.80216E+12	1.80216E+12	20.72	0.000
Residual Error	46	4.00040E+12	86965247036		
Total	47	5.80256E+12			

Unusual Observations

Obs	two digi	EMRM	Fit	SE Fit	Residual	St Resid
12	1.00	1800408	1170779	53360	629629	2.17R
38	-2.00	1995090	757175	72491	1237915	4.33R

R denotes an observation with a large standardized residual

Atlantic Fleet

Regression Analysis: EMRM versus two digit year

The regression equation is

EMRM = 980124 + 191390 two digit year

MAPE = 17.6%

Predictor	Coef	SE Coef	T	P
Constant	980124	39110	25.06	0.000
two digi	191390	27905	6.86	0.000

S = 206344 R-Sq = 64.4% R-Sq(adj) = 63.0%

Analysis of Variance

Source	DF	SS	MS	F	P
Regression	1	2.00288E+12	2.00288E+12	47.04	0.000
Residual Error	26	1.10702E+12	42577801017		

Total 27 3.10991E+12

Unusual Observations

Obs	two digi	EMRM	Fit	SE Fit	Residual	St Resid
12	1.00	1800408	1171514	49751	628894	3.14R

Japan

Regression Analysis: EMRM versus two digit year

The regression equation is

EMRM = 903463 + 131279 two digit year

MAPE = 13.6%

Predictor	Coef	SE Coef	T	P
Constant	903463	53327	16.94	0.000
two digi	131279	37708	3.48	0.008

S = 168635 R-Sq = 60.2% R-Sq(adj) = 55.3%

Analysis of Variance

Source	DF	SS	MS	F	P
Regression	1	3.44682E+11	3.44682E+11	12.12	0.008
Residual Error	8	2.27503E+11	28437877086		
Total	9	5.72185E+11			

Bahrain

There were no significant regressions.

MHC Class

SO

Regression Analysis: OTHER versus 2 digit year

The regression equation is
OTHER = 191950 + 46602 2 digit year
MAPE = 30.8%

Predictor	Coef	SE Coef	T	P
Constant	191950	13492	14.23	0.000
2 digit	46602	8788	5.30	0.000

S = 47732 R-Sq = 70.1% R-Sq(adj) = 67.6%

Analysis of Variance

Source	DF	SS	MS	F	P
Regression	1	64065866492	64065866492	28.12	0.000
Residual Error	12	27339614865	2278301239		
Total	13	91405481357			

Regression Analysis: OTHER versus Total UW

The regression equation is
OTHER = 66933 + 1605 Total UW
MAPE 35.1%

Predictor	Coef	SE Coef	T	P
Constant	66933	46455	1.44	0.175
Total UW	1605.5	667.9	2.40	0.033

S = 71705 R-Sq = 32.5% R-Sq(adj) = 26.9%

Analysis of Variance

Source	DF	SS	MS	F	P
Regression	1	29705901221	29705901221	5.78	0.033
Residual Error	12	61699580136	5141631678		
Total	13	91405481357			

Unusual Observations

Obs	Total UW	OTHER	Fit	SE Fit	Residual	St Resid
1	80	346982	195369	22155	151613	2.22R

R denotes an observation with a large standardized residual

SR

Regression Analysis: EMRM versus 2 digit year

The regression equation is
EMRM = 492140 + 164273 2 digit year
MAPE = 40.0 %

Predictor	Coef	SE Coef	T	P
Constant	492140	43170	11.40	0.000
2 digit	164273	28118	5.84	0.000

S = 152722 R-Sq = 74.0% R-Sq(adj) = 71.8%

Analysis of Variance

Source	DF	SS	MS	F	P
Regression	1	7.96076E+11	7.96076E+11	34.13	0.000
Residual Error	12	2.79890E+11	23324152965		
Total	13	1.07597E+12			

APPENDIX F: REGRESSIONS TO CALCULATE SUPPLEMENTAL FUNDING REQUIREMENTS

The regressions presented in Chapter Five summarize those with the best MAPE regardless of variables included in the equation. Only regressions that include independent variables for operational data are included in this appendix. While these variables did not optimize MAPE for our modified model they are significant to the ninety percent level for the regression as well as each independent variable.

Regressions were run to find relationships between repair parts (SR) cost, consumable (SO) costs and operating data. An independent variable for the year was considered. Referred to as “FY” this variable aimed to include trends from year to year, to include inflation. An indicator variable was included to differentiate between Pacific and Atlantic Fleet ships when regressions were run on all the ships of a class when aggregated. This variable was referred to as “Pac Flt.” This variable has a value of either “1” for a Pacific Fleet ship or “0” for an Atlantic Fleet ship. This variable was not included when the regressions were done for the individual fleets since it was not required.

Based on the information in the NUERS database, five possible independent variables could be considered. The first was Days Underway while not deployed and was identified as “UW not dep.” There were three variables to consider for days underway while deployed. Days underway deployed to the Fifth Fleet Area of Responsibility (AOR) are identified separately in the NUERS database by OPCON code 17. The variable representing this is “code 17” in the following regressions. When ships were deployed but not to the Fifth Fleet AOR, these days were represented by the variable “UW dep not 17”. Finally, the variable “Total UW deployed” is the summation of the previous two variables. The last variable “Total UW” considers the total number of days underway deployed and not deployed.

Some exceptions apply. Due to the lack of data points, regressions by class do not consider whether a ship is deployed to Fifth Fleet or not, only that it is underway deployed. Further, in order to keep with the model’s current convention of computing unit cost for SR and SO and then multiplying by the number of Ship Years, we have decided

to use the dependent variable SR per ship (or SO per ship) when determining the equation to predict costs by class.

To summarize, the variables used in the following regressions and their meanings are as follows:

SR	A dependent variable to estimate repair parts costs when using “by hull” data.
SO	A dependent variable to estimate SO consumable costs when using “by hull” data.
SR per ship	A dependent variable to estimate SR costs when using class data.
SO per ship	A dependent variable to estimate SO costs when using class data.
FY	An independent variable representing the current fiscal year. Fiscal Year 2000 was used as the base (00). Therefore fiscal year 1999 is represented by a negative one (-1) and fiscal year 2001 by a positive one (1).
Pac Flt	A binary (one or zero) indicator variable to represent the fleet in which a ship is home ported. A ship assigned to the Atlantic Fleet would have a value of zero and one assigned to the Pacific Fleet would have a value of one.
UW not dep	Represents the days spent underway and while not in a deployed status. In the NUERS database this is represented by the time spent in code eight.
Code 17	Represents the days underway on deployment while in the 5 th Fleet AOR. This time is represented by code 17 in the NUERS database.
UW dep not 17	Represents the days spent underway and on deployment when operating in areas SO than the 5 th fleet AOR. This is represented by the code nine in the NUERS database.
Total UW deployed	Is the summation of the days under “Code 17” and “Total UW deployed.” This represents the total number of days underway while in a deployed status.
Total UW	Represents the total number of days a ship was underway in a year. It is the summation of the time spent in codes eight, nine and seventeen in the NUERS database.
Total UW / SY	The total days underway for a class during a year divided by the ship years. This represents the average number of days underway per ship.

Table 23: List of Variables Used in Regressions in Appendix F

Multiple regressions were run in Minitab (a commercial statistical software package) to consider the various combinations of these variables. In order to find any relationships that exist across an entire class, the ships were aggregated by class and fleet.

Then the ships were divided into their respective fleets and further regressions were performed to find any relationships that were fleet specific.

There are a few exceptions to this practice. Only ships from the Atlantic Fleet were considered for the CVN-68 class. Data for the Pacific Fleet ships of this class were not available. The MCM class does not have ships assigned to the Pacific Fleet. Ships are home ported in the Atlantic Fleet, Bahrain and Japan. Although assigned to Japan, for budgeting purposes these ships are considered part of the Atlantic Fleet. Regressions performed on this class of ship were separated by homeport, Atlantic, Bahrain and Japan. The MHC class had a similar issue since these ships are only home ported in Bahrain.

A summary of the regressions follows with the corresponding MAPE for each regression equation. The MAPE was obtained by comparing the error produced by the predictive regression and the actual costs, as discussed in Chapter 4. The complete statistical evaluation of the regressions including an analysis of variance (ANOVA) can be found in Appendices C and D.

The regressions are subdivided by Other Consumables (SO) and Repair Parts (SR).

AOE-1 Class

SR

By Hull

One regression was found to be significant for the entire class for this Special Interest Item:

$$\text{SR} = 1179276 + 194205 \text{ FY} - 447725 \text{ Pac Flt} + 2952 \text{ Total UW}$$
$$\text{MAPE} = 27.9\%$$

One regression was found to be significant for the AOE-1 class ships assigned to the Atlantic Fleet:

$$\text{SR} = 1216456 + 168466 \text{ FY} + 2679 \text{ Total UW}$$
$$\text{MAPE} = 9.8\%$$

AOE-6 Class

SO

By Hull

Two regressions were found to be significant for the entire class for this Special Interest Item. They are:

$$\text{SO} = 230024 + 585647 \text{ Pac Flt} + 3912 \text{ Total UW}$$
$$\text{MAPE} = 19.9\%$$

$$\text{SO} = - 7758 + 577636 \text{ Pac Flt} + 7567 \text{ UW not dep} + 3842 \text{ Total UW deployed}$$
$$\text{MAPE} = 21.7\%$$

Two regressions were found to be significant for the AOE-6 class ships assigned to the Atlantic Fleet. They are:

$$\text{SO} = 389230 - 95086 \text{ FY} + 2493 \text{ Total UW}$$
$$\text{MAPE} = 15.1\%$$

$$\text{SO} = 315716 + 3238 \text{ Total UW}$$
$$\text{MAPE} = 18.4\%$$

No regressions were found to be significant for the AOE-6 class ships assigned to the Pacific Fleet.

SR

By Hull

One regression was significant for SR for the entire class of ships. It is:

$$\text{SR} = 461317 - 290374 \text{ Pac Flt} + 10861 \text{ UW not dep} + 5132 \text{ Total UW deployed}$$
$$\text{MAPE}=14.7\%$$

ARS Class

SR

By Hull

There was one regression that was significant when the ARS class was considered as a

$$\text{SR per ship} = -78.593 + 66.767 \text{ FY} + 281.541 \text{ Pac Flt} + 5.6568 \text{ Total UW} / \text{SY}$$
$$\text{MAPE} = 25.6\%$$

CG-47 Class

SO

By Hull

Two regressions were found to be significant for the entire class for this Special Interest Item. They are:

$$\text{SO} = 589434 + 86589 \text{ FY} + 1312 \text{ Total UW}$$
$$\text{MAPE} = 19.0\%$$

$$\text{SO} = 519990 + 70221 \text{ FY} + 244877 \text{ Pac Flt} + 1061 \text{ Total UW}$$
$$\text{MAPE} = 14.3\%$$

Two regressions were found to be significant for the ships of the Atlantic Fleet when considered separately:

$$\text{SO} = 545267 + 65314 \text{ FY} + 973 \text{ UW not dep} + 599 \text{ Total UW Deployed}$$
$$\text{MAPE} = 20.1\%$$

$$\text{SO} = 566698 + 65111 \text{ FY} + 674 \text{ Total UW}$$
$$\text{MAPE} = 15.4\%$$

One regression was found to be significant for the ships of the Pacific Fleet when considered separately:

$$\text{SO} = 667532 + 81913 \text{ FY} + 1754 \text{ Total UW}$$
$$\text{MAPE} = 36.2$$

SR

By Hull

Four regressions were found to be significant for the entire class for this Special Interest Item. They are:

$$\text{SR} = 2274423 + 279975 \text{ FY} + 3268 \text{ UW not dep} + 2655 \text{ Total UW Deployed}$$
$$\text{MAPE} = 13.2\%$$

$$\text{SR} = 2351259 + 290770 \text{ FY} - 171724 \text{ Pac Flt} + 3011 \text{ UW not dep}$$
$$+ 2896 \text{ Total UW Deployed}$$
$$\text{MAPE} = 13.0\%$$

$$\text{SR} = 2309035 + 279134 \text{ FY} + 2736 \text{ Total UW}$$
$$\text{MAPE} = 13.4\%$$

$$\text{SR} = 2358455 + 290782 \text{ FY} - 174269 \text{ Pac Flt} + 2914 \text{ Total UW}$$
$$\text{MAPE} = 13.1\%$$

Two regressions were found to be significant for the ships of the Atlantic Fleet when considered separately:

$$\text{SR} = 2363303 + 314474 \text{ FY} + 3231 \text{ UW not dep} + 2131 \text{ Total UW Deployed}$$
$$\text{MAPE} = 14.1\%$$

$$\text{SR} = 2426207 + 313876 \text{ FY} + 2353 \text{ Total UW}$$
$$\text{MAPE} = 14.3\%$$

Two regressions were found to be significant for the ships of the Pacific Fleet when considered separately:

$$\text{SR} = 2107506 + 242910 \text{ FY} + 3367 \text{ UW not dep} + 3944 \text{ Total UW Deployed}$$
$$\text{MAPE} = 11.2\%$$

$$\text{SR} = 2078288 + 242080 \text{ FY} + 3901 \text{ Total UW}$$
$$\text{MAPE} = 11.2\%$$

CVN-68 Class

SO

By Hull

Two regressions were found to be significant for the ships of the Atlantic Fleet when considered separately:

$$SO = 5204351 + 781017 \text{ FY} + 20101 \text{ Total UW}$$

$$\text{MAPE} = 16.2\%$$

$$SO = 4575298 + 23681 \text{ Total UW}$$

$$\text{MAPE} = 18.6$$

SR

By Hull

Four regressions were found to be significant for the ships of the Atlantic Fleet when considered separately:

$$SR = 2977027 + 681646 \text{ FY} + 29933 \text{ UW not dep} + 21332 \text{ Total UW deployed}$$

$$\text{MAPE} = 27.0\%$$

$$SR = 3332599 + 731389 \text{ FY} + 23395 \text{ Total UW}$$

$$\text{MAPE} = 26.9\%$$

$$SR = 2977027 + 681646 \text{ FY} + 29933 \text{ UW not dep} + 21332 \text{ Total UW deployed}$$

$$\text{MAPE} = 27.0\%$$

$$SR = 2743518 + 26748 \text{ Total UW}$$

$$\text{MAPE} = 27.4\%$$

DD-963 Class

SO

By Hull

Two regressions were found to be significant for the entire class for this Special Interest Item. They are:

$$\text{SO} = 331935 + 43634 \text{ FY} + 372565 \text{ Pac Flt} + 1856 \text{ UW not dep} + 1859 \text{ Total UW Deployed.}$$

MAPE = 22.8

$$\text{SO} = 327688 + 43430 \text{ FY} + 375341 \text{ Pac Flt} + 1884 \text{ UW not dep} + 2017 \text{ UW Dep not 17} + 1673 \text{ Code 17}$$

MAPE = 19.5%

One regression was found to be significant for the ships of the Atlantic Fleet when considered separately:

$$\text{SO} = 455668 + 39223 \text{ FY} + 749 \text{ Total UW}$$

MAPE = 16.9%

Three regressions were found to be significant for the ships of the Pacific Fleet when considered separately:

$$\text{SO} = 384708 + 65132 \text{ FY} + 3927 \text{ UW not dep} + 5179 \text{ UW Dep not 17} + 3310 \text{ Code 17}$$

MAPE = 15.9%

$$\text{SO} = 418276 + 60375 \text{ FY} + 3897 \text{ Total UW}$$

MAPE = 16.0%

$$\text{SO} = 448379 + 3882 \text{ Total UW}$$

MAPE = 17.7%

SR

By Hull

Three regressions were found to be significant for the entire class for this Special Interest Item. They are:

$$\text{SR} = 1530061 + 152196 \text{ FY} + 4881 \text{ UW not dep} \\ + 3923 \text{ UW Dep not 17} + 3683 \text{ Code 17} \\ \text{MAPE} = 21.2$$

$$\text{SR} = 1532637 + 152182 \text{ FY} + 4860 \text{ UW not dep} \\ + 3807 \text{ Total UW Deployed} \\ \text{MAPE} = 22.1$$

One regression was found to be significant for the ships of the Atlantic Fleet when considered separately:

$$\text{SR} = 1720829 + 228806 \text{ FY} + 3050 \text{ Total UW} \\ \text{MAPE} = 29.4\%$$

Three regressions were found to be significant for the ships of the Pacific Fleet when considered separately:

$$\text{SR} = 1341095 + 5605 \text{ UW not dep} + 8467 \text{ UW Dep not 17} + 4489 \text{ Code 17} \\ \text{MAPE} = 18.4\%$$

$$\text{SR} = 1465298 + 4463 \text{ UW not dep} + 5898 \text{ Total UW Deployed} \\ \text{MAPE} = 22.1\%$$

$$\text{SR} = 1398205 + 5716 \text{ Total UW} \\ \text{MAPE} = 33.9\%$$

DDG-51 Class

SO

By Hull

Three regressions were found to be significant for the entire class for this Special Interest Item. They are:

$$\text{SO} = 100447 + 41255 \text{ FY} + 190405 \text{ Pac Flt} + 3605 \text{ UW not dep} \\ + 3130 \text{ UW Dep not 17} + 2576 \text{ Code 17} \\ \text{MAPE} = 23.9\%$$

$$\text{SO} = 212997 + 51850 \text{ FY} + 2984 \text{ Total UW} \\ \text{MAPE} = 24.3\%$$

$$\text{SO} = 151319 + 40916 \text{ FY} + 177117 \text{ Pac Flt} + 2920 \text{ Total UW}$$
$$\text{MAPE} = 25.5$$

Two regressions were found to be significant for the ships of the Atlantic Fleet when considered separately:

$$\text{SO} = 193428 + 49367 \text{ FY} + 3030 \text{ UW not dep} + 1906 \text{ UW Dep not 17}$$
$$+ 1663 \text{ Code 17}$$
$$\text{MAPE} = 21.7\%$$

$$\text{SO} = 246691 + 43832 \text{ FY} + 2107 \text{ Total UW}$$
$$\text{MAPE} = 23.3\%$$

Three regressions were found to be significant for the ships of the Pacific Fleet when considered separately:

$$\text{SO} = 126572 + 40860 \text{ FY} + 4890 \text{ UW not dep} + 5099 \text{ Uw Deployed Not 17} + 3320$$
$$\text{Code 17}$$
$$\text{MAPE} = 20.8\%$$

$$\text{SO} = 166433 + 39827 \text{ FY} + 4378 \text{ UW not dep} + 4123 \text{ Total UW Deployed}$$
$$\text{MAPE} = 21.2\%$$

$$\text{SO} = 180099 + 40288 \text{ FY} + 4132 \text{ Total UW}$$
$$\text{MAPE} = 21.2\%$$

SR

By Hull

Two regressions were found to be significant for the entire class for this Special Interest Item. They are:

$$\text{SR} = 400753 + 10018 \text{ UW not dep} + 7212 \text{ UW Dep not 17} + 7280 \text{ Code 17}$$
$$+ 103074 \text{ FY}$$
$$\text{MAPE} = 26.5\%$$

$$\text{SR} = 562075 + 99154 \text{ FY} + 7482 \text{ Total UW}$$
$$\text{MAPE} = 26.8$$

Three regressions were found to be significant for the ships of the Atlantic Fleet when considered separately:

$$\begin{aligned} \text{SR} &= 429539 + 113649 \text{ FY} + 10825 \text{ UW not dep} + 3968 \text{ UW Dep not 17} \\ &\quad + 6475 \text{ Code 17} \\ \text{MAPE} &= 24.5\% \end{aligned}$$

$$\begin{aligned} \text{SR} &= 392123 + 112791 \text{ FY} + 11212 \text{ UW not dep} + 5113 \text{ Total UW deployed} \\ \text{MAPE} &= 24.6\% \end{aligned}$$

$$\begin{aligned} \text{SR} &= 674755 + 92003 \text{ FY} + 6475 \text{ Total UW} \\ \text{MAPE} &= 27.2\% \end{aligned}$$

Two regressions were found to be significant for the ships of the Pacific Fleet when considered separately:

$$\begin{aligned} \text{SR} &= 248942 + 10652 \text{ UW not dep} + 11890 \text{ Uw Deployed Not 17} + 6623 \text{ Code 17} \\ &\quad + 120507 \text{ FY} \\ \text{MAPE} &= 23.9\% \end{aligned}$$

$$\begin{aligned} \text{SR} &= 366956 + 9136 \text{ UW not dep} + 9000 \text{ Total UW Deployed} \\ &\quad + 117450 \text{ FY} \\ \text{MAPE} &= 25.2\% \end{aligned}$$

FFG Class

SO

By Hull

Three regressions were found to be significant for the entire class for this Special Interest Item. They are:

$$\begin{aligned} \text{SO} &= 253249 + 57776 \text{ FY} + 298451 \text{ Pac Flt} + 1936 \text{ UW not dep} \\ &\quad + 1010 \text{ UW Dep not 17} + 1602 \text{ Code 17} \\ \text{MAPE} &= 19.8\% \end{aligned}$$

$$\begin{aligned} \text{SO} &= 284174 + 57251 \text{ FY} + 283864 \text{ Pac Flt} + 1494 \text{ Total UW} \\ \text{MAPE} &= 19.8\% \end{aligned}$$

One regression was found to be significant for the ships of the Atlantic Fleet when considered separately:

$$\text{SO} = 395351 + 64795 \text{ FY} + 603 \text{ Total UW}$$
$$\text{MAPE} = 17.4\%$$

Three regressions were found to be significant for the ships of the Pacific Fleet when considered separately:

$$\text{SO} = 399035 + 46848 \text{ FY} + 2818 \text{ Total UW}$$
$$\text{MAPE} = 19.2\%$$

$$\text{SO} = 410151 + 2911 \text{ Total UW}$$
$$\text{MAPE} = 20.0\%$$

$$\text{SO} = 367734 + 3749 \text{ UW not dep} + 2382 \text{ UW Dep} + 3003 \text{ Code 17}$$
$$\text{MAPE} = 20.5\%$$

SR

By Hull

Two regressions were found to be significant for the entire class for this Special Interest Item. They are:

$$\text{SR} = 1114799 + 117170 \text{ FY} + 3286 \text{ UW not dep} + 1569 \text{ Total UW Deployd}$$
$$\text{MAPE} = 17.5\%$$

$$\text{SR} = 1183994 + 140115 \text{ FY} - 264124 \text{ Pac Flt} + 3278 \text{ UW not dep}$$
$$+ 2182 \text{ Total UW Deployd}$$
$$\text{MAPE} = 16.1\%$$

Two regressions were found to be significant for the ships of the Atlantic Fleet when considered separately:

$$\text{SR} = 1199609 + 189197 \text{ FY} + 3498 \text{ UW not dep} + 1826 \text{ Total UW dep}$$
$$\text{MAPE} = 15.6\%$$

$$\text{SR} = 1265013 + 187084 \text{ FY} + 2496 \text{ Total UW}$$
$$\text{MAPE} = 15.6\%$$

LHA-1 Class

SO

By Class

No regressions were found to be significant for the ships of the Pacific Fleet when considered separately:

$$\text{SO per ship} = 1530.214 + 155.7285 \text{ FY} + 10.337 \text{ Total UW} / \text{SY}$$
$$\text{MAPE} = 12.0\%$$

$$\text{SO per ship} = 1442.206 + 184.4804 \text{ FY} + 12.8445 \text{ Total UW} / \text{SY}$$
$$\text{MAPE} = 10.5\%$$

LHD Class

SO

By Hull

Two regressions were found to be significant for the entire class for this Special Interest Item. They are:

$$\text{SO} = 1060138 + 591557 \text{ Pac Flt} + 4965 \text{ Total UW}$$
$$\text{MAPE} = 21.1\%$$

$$\text{SO} = 1195299 + 5858 \text{ Total UW}$$
$$\text{MAPE} = 26.3\%$$

One regression was found to be significant for the ships of the Atlantic Fleet when considered separately:

$$\text{SO} = 1109434 + 4534 \text{ Total UW}$$
$$\text{MAPE} = 17.6\%$$

SR

By Hull

Three regressions were found to be significant for the entire class for this Special Interest Item. They are:

$$\text{SR} = 1156393 + 124175 \text{ FY} + 9707 \text{ UW not dep} + 7426 \text{ Total Dep UW}$$
$$\text{MAPE} = 15.3$$

$$\text{SR} = 1290522 + 113189 \text{ FY} + 7522 \text{ Total UW}$$
$$\text{MAPE} = 15.4\%$$

$$\text{SR} = 1025405 + 11963 \text{ UW not dep} + 4940 \text{ UW Dep not 17} + 11242 \text{ Code 17}$$
$$\text{MAPE} = 14.8\%$$

Three regressions were found to be significant for the ships of the Atlantic Fleet when considered separately:

$$\text{SR} = 785076 + 16559 \text{ UW not dep} + 4675 \text{ UW Dep not 17} + 13331 \text{ Code 17}$$
$$\text{MAPE} = 12.6\%$$

$$\text{SR} = 827705 + 15099 \text{ UW not dep} + 8581 \text{ Total Dep UW}$$
$$\text{MAPE} = 15.8\%$$

$$\text{SR} = 1196309 + 9152 \text{ Total UW}$$
$$\text{MAPE} = 17.8\%$$

Two regressions were found to be significant for the ships of the Pacific Fleet when considered separately:

$$\text{SR} = 1395677 + 186636 \text{ FY} + 5703 \text{ Total UW}$$
$$\text{MAPE} = 11.5\%$$

$$\text{SR} = 1396541 + 6391 \text{ Total UW}$$
$$\text{MAPE} = 13.1\%$$

LPD Class

SO

By Hull

One regression was found to be significant for the entire class for this Special Interest Item. They are:

$$\text{SO} = 459942 + 47618 \text{ FY} + 493034 \text{ Pac Flt} + 2381 \text{ Total UW}$$
$$\text{MAPE} = 15.7\%$$

Two regressions were found to be significant for the ships of the Pacific Fleet when considered separately:

$$\text{SO} = 691450 + 4762 \text{ Total UW}$$
$$\text{MAPE} = 15.0\%$$

$$\text{SO} = 629996 + 5102 \text{ UW not dep} + 6866 \text{ Uw Deployed not 17} + 3522 \text{ Code 17}$$
$$\text{MAPE} = 14.4\%$$

SR

By Hull

Three regressions were found to be significant for the entire class for this Special Interest Item. They are:

$$\text{SR} = 588844 + 87060 \text{ FY} + 3051 \text{ UW not dep} + 1639 \text{ Total Deployed}$$
$$\text{MAPE} = 17.8\%$$

$$\text{SR} = 686844 + 86693 \text{ FY} + 1544 \text{ Total UW}$$
$$\text{MAPE} = 18.2\%$$

Three regressions were found to be significant for the ships of the Pacific Fleet when considered separately:

$$\text{SR} = 515894 + 95973 \text{ FY} + 3626 \text{ UW not dep} + 2633 \text{ Total Deployed}$$
$$\text{MAPE} = 18.3\%$$

$$\text{SR} = 576194 + 96696 \text{ FY} + 2593 \text{ Total UW}$$
$$\text{MAPE} = 18.5\%$$

LSD-36 Class

SO

One regression was found to be significant for the ships of the Pacific Fleet when considered separately:

$$\text{SO} = -176656 + 10929 \text{ Total UW}$$
$$\text{MAPE} = 22.6\%$$

SR

By Hull

Three regressions were found to be significant for the ships of the Pacific Fleet when considered separately:

$$\text{SR} = 132031 + 210208 \text{ FY} + 6168 \text{ UW not dep} + 3274 \text{ UW Dep}$$
$$+ 3783 \text{ Code 17}$$
$$\text{MAPE} = 3.3\%$$

$$\text{SR} = 132195 + 210146 \text{ FY} + 6100 \text{ UW not dep} + 3526 \text{ Total Dep UW}$$
$$\text{MAPE} = 2.8\%$$

$$\text{SR} = 313960 + 210862 \text{ FY} + 3385 \text{ Total UW}$$
$$\text{MAPE} = 4.9\%$$

LSD-41 Class

SO

By Hull

One regression was found to be significant for the entire class for this Special Interest Item. They are:

$$\text{SO} = 384471 + 46986 \text{ FY} + 370971 \text{ Pac Flt} + 1803 \text{ Total UW}$$
$$\text{MAPE} = 20.5\%$$

One regression was found to be significant for the ships of the Pacific Fleet when considered separately:

$$\text{SO} = 513888 + 3846 \text{ Total UW}$$
$$\text{MAPE} = 19.0\%$$

SR

No regressions were significant for this SII.

MCM Class

SO

By Hull

One regression was found to be significant for the entire class for this Special Interest Item. They are:

$$\text{SO} = 191822 + 22134 \text{ FY} + 604 \text{ Total UW}$$
$$\text{MAPE} = 13.4\%$$

One regression was found to be significant for the ships home-ported in Japan when considered separately:

$$\text{SO} = 173739 + 1187 \text{ Total UW}$$
$$\text{MAPE} = 11.3\%$$

SR

By Hull

One regression was found to be significant for the entire class for this Special Interest Item. They are:

$$\begin{aligned} \text{SR} &= 792553 + 125855 \text{ FY} + 2878 \text{ Total UW} \\ \text{MAPE} &= 19.9\% \end{aligned}$$

MHC Class

SO

By Hull

One regression was found to be significant for the entire class for this Special Interest Item:

$$\begin{aligned} \text{SO} &= 66933 + 1605 \text{ Total UW} \\ \text{MAPE} &= 35.1\% \end{aligned}$$

SR

No regressions were significant for this SII.

APPENDIX G: RECOMMENDATIONS FOR DEVELOPING NEW MODELS

We conducted our analysis of the current model and our development of a modified model with an overall precept that any change to the model must be statistically significant at the 90% level. While the current model may not be statistically significant, we did not feel comfortable replacing parts of the current model without the statistical significance to support the change. If we relaxed the requirement for all changes to be statistically significant we could explore other options for improving the model without completely overhauling the current methodology.

Here is an example of potential models. Models A, B and C use the current methodology of a three year moving average but instead of multiplying unit cost by Ship Years as the driver, we use OPMONTH, total days underway and a weighted mix of ship year, OPMONTH and total days underway respectively. The current model's methodology is maintained but the drivers are different. To gain further insight into the potential for altering the current model to improve its output we developed sub-models to models A, B and C. We have labeled them A1, A2, B1, etc. In each sub-model 1, incremental costs were excluded for each year. In sub-model 2, in addition to excluding incremental costs, price growth factors were excluded. As an initial analysis of this methodology, we have developed backcasts for the selected five ship classes below and calculated the MAPE based on 6 years for each model.

Model Codes	Description	MAPEs of		Improvement	
		SR	SO	SR	SO
Original	<i>Original</i>	14.12%	21.34%	-	-
Model O2	+ w/o inc. cost and price growth	12.08%	20.48%	2.04%	0.86%
Model A	<i>based on OPMONTH</i>	17.11%	22.57%	-	-
Model A1	+ w/o inc. costs	15.31%	22.53%	-	-
Model A2	+ w/o price growth	13.46%	21.87%	0.65%	-
Model B	<i>based on TDUW</i>	25.22%	25.69%	-	-
Model B1	+ w/o inc. costs	23.30%	25.69%	-	-
Model B2	+ w/o price growth	20.57%	25.70%	-	-
Model C	<i>Optimized mix of SYr, OPM and TDUW</i>	13.76%	20.53%	0.36%	0.81%
Model C1	+ w/o inc. costs	12.27%	20.48%	1.85%	0.86%
Model C2	+ w/o price growth	11.12%	20.28%	3.00%	1.06%
Overall Results	Best value:	11.12%	20.28%		
	Best Model:	Model C2	Model C2		

w/o LHA-1CL

Model Codes	Description	MAPEs of		Improvement	
		SR	SO	SR	SO
Original	<i>Original</i>	11.75%	22.28%	-	-
Model O2	+ w/o inc. cost and price growth	9.96%	20.83%	1.79%	1.44%
Model A	<i>based on OPMONTH</i>	13.26%	22.07%	-	0.20%
Model A1	+ w/o inc. costs	11.28%	22.02%	0.47%	0.25%
Model A2	+ w/o price growth	9.45%	20.92%	2.30%	1.35%
Model B	<i>based on TDUW</i>	16.51%	24.50%	-	-
Model B1	+ w/o inc. costs	14.66%	24.50%	-	-
Model B2	+ w/o price growth	12.72%	23.78%	-	-
Model C	<i>Optimized mix of SYr, OPM and TDUW</i>	11.29%	21.26%	0.45%	1.02%
Model C1	+ w/o inc. costs	9.32%	21.20%	2.43%	1.07%
Model C2	+ w/o price growth	8.77%	20.59%	2.98%	1.69%
Overall Results	Best value:	8.77%	20.59%		
	Best Model:	Model C2	Model C2		

Table 24: Alternative Model Comparison

In Model A, which uses the same three year moving average as the original model, but calculates unit costs based on OPMONTH instead of ship years, we see some improvement. As we can see in Table 23, A2 results in a better MAPE on the selected sample, especially if we exclude the LHA-1 ship class, which seems to be an outlier. However, the limited number of ships is a small sample and limits our ability to draw conclusions but demonstrates an area for future research

Model B, which uses unit costs based on total days underway, produces an even worse MAPE in our sample. This alone does not say that days underway has no relationship with the certain cost elements, but it suggests that we can exclude the simple solu-

tion of just changing the cost-driver for SR and SO to total days underway for all classes in the model. Again, it does not mean the lack of relationship (relationship in this case was actually not even examined statistically), it just says, there is not a simple connection between the cost elements as a whole and total day underway. In fact, as our research has shown, when applied on class-by-class basis operational variables such as days underway can have a significant relationship with cost.

For Model C we used the solver function of Microsoft Excel to find the optimal mix of unit costs based on ship years, OPMONTH and total days underway. Changing the weight of these cost drivers, we optimized the weighting of each variable with the objective of minimizing MAPE of each ship class in our sample separately. For instance Table 24 shows the weight of ship years at the optimum solution.

Weights of Syr in the best cases	C		C1		C2	
	SR	SO	SR	SO	SR	SO
DDG-51	0%	0%	0%	0%	0%	0%
CG-47	100%	9%	23%	4%	55%	0%
DD-963	81%	100%	83%	100%	0%	100%
FFG-7	100%	33%	100%	38%	81%	56%
LHA-1	100%	100%	100%	100%	100%	100%
Average:	76%	48%	61%	48%	47%	51%

Table 25: Weights of Ship Year Unit Costs in Model C

Though Model C resulted in significant improvement, it is more an interesting experiment than an easily usable and established method. Just like regressions, it was aimed to reduce errors (here measured by MAPE). The interesting concept from this model is that, based on past data, we constructed a simple model that determines which cost-driver has the biggest influence on cost. In the case of LHA-1, ship years are clearly the best independent variable from the examined three. While in other cases, the significance of ship year is quite mixed and changes with model variants. We see the potential for further study in this area.

Potentially the most important take away from Table 23 is the difference in sub-model (e.g. A2) and the primary model (e.g. A). In every case, excluding incremental cost and price growth factors results in an improved MAPE. This discovery led us to compare the original model and the original without these factors and, as shown above (O vs. O2), by excluding them we observe an improved MAPE. This is further evidence that, as has previously been discussed, the manners in which price growth factors are determined as well as the incremental cost determination process are areas for potential research.

These models represent a potential means of improving the model without using regression analysis. The advantage of such potential improvements is that the resulting model would be in very much the same format as the original. Further research is required to determine whether such a change would be an improvement overall.

APPENDIX H: MAPE COMPARISON TABLES FOR THE MODIFIED MODELS

SO	Original Model MAPE	Regr. MAPE by HULL	Combined Regr. MAPE by HULL	Regr. MAPE by Class	Combined Regr. MAPE by Class	Best Value	Best Method
Atlantic Fleet							
AOE-1CL	10.10%	No Signif.	No Signif.	11.9%	25.4%	10.10%	<i>Original Model</i>
AOE-6CL	56.04%	15.10%	19.90%	No Signif.	No Signif.	15.10%	<i>Regression by HULL</i>
MHC-51CL	70.86%	No Signif.	30.80%	No Signif.	No Signif.	30.80%	<i>Regression by HULL Combined</i>
LHA-1CL	17.31%	18.30%	18.00%	7.1%	12.0%	7.10%	<i>Regression by Class</i>
LHD-1CL	17.68%	17.60%	21.10%	9.4%	14.7%	9.40%	<i>Regression by Class</i>
LPD-4CL	75.43%	10.30%	15.70%	No Signif.	28.8%	10.30%	<i>Regression by HULL</i>
LSD-36CL	52.35%	No Signif.	27.50%	No Signif.	No Signif.	27.50%	<i>Regression by HULL Combined</i>
LSD-41CL	27.20%	24.80%	20.50%	No Signif.	No Signif.	20.50%	<i>Regression by HULL Combined</i>
CG-47CL	12.28%	15.10%	14.30%	6.4%	No Signif.	6.40%	<i>Regression by Class</i>
DDG-51CL	13.52%	21.70%	23.90%	6.7%	No Signif.	6.70%	<i>Regression by Class</i>
DD-963CL	8.77%	16.10%	17.70%	6.0%	14.4%	6.00%	<i>Regression by Class</i>
FFG-7CL	10.29%	17.40%	19.20%	3.7%	10.6%	3.70%	<i>Regression by Class</i>
ARS-50CL	16.93%	13.00%	18.60%	7.0%	11.8%	7.00%	<i>Regression by Class</i>
CVN-68CL	9.52%	16.20%	N/A	No Signif.	No Signif.	9.52%	<i>Original Model</i>
Pacific Fleet							
AOE-1CL	16.87%	No Signif.	No Signif.	No Signif.	25.4%	16.87%	<i>Original Model</i>
AOE-6CL	26.38%	No Signif.	19.90%	39.8%	No Signif.	19.90%	<i>Regression by HULL Combined</i>
LHA-1CL	17.60%	No Signif.	18.00%	10.5%	12.0%	10.50%	<i>Regression by Class</i>
LHD-1CL	21.84%	No Signif.	21.10%	16.9%	14.7%	14.70%	<i>Regression by Class Combined</i>
LPD-4CL	11.93%	14.40%	15.70%	7.3%	28.8%	7.30%	<i>Regression by Class</i>
LSD-36CL	18.38%	21.20%	27.50%	13.8%	No Signif.	13.80%	<i>Regression by Class</i>
LSD-41CL	23.50%	19.00%	20.50%	No Signif.	No Signif.	19.00%	<i>Regression by HULL</i>
CG-47CL	20.15%	17.10%	14.30%	No Signif.	No Signif.	14.30%	<i>Regression by HULL Combined</i>
DDG-51CL	30.59%	20.80%	23.90%	No Signif.	No Signif.	20.80%	<i>Regression by HULL</i>
DD-963CL	24.15%	15.90%	17.70%	17.8%	14.4%	14.40%	<i>Regression by Class Combined</i>
FFG-7CL	14.22%	19.20%	19.20%	12.9%	10.6%	10.60%	<i>Regression by Class Combined</i>
ARS-50CL	14.97%	13.10%	18.60%	16.4%	11.8%	11.80%	<i>Regression by Class Combined</i>
CVN-68CL	20.00%	N/A	N/A	No Signif.	No Signif.	20.00%	<i>Original Model</i>

Table 26: MAPE Comparison for Modified Models SO

SR	Original Model MAPE	Regr. MAPE by HULL	Combined Regr. MAPE by HULL	Regr. MAPE by Class	Combined Regr. MAPE by Class	Best Value	Best Method
Atlantic Fleet							
AOE-1CL	9.84%	13.40%	19.60%	No Signif.	No Signif.	9.84%	<i>Original Model</i>
AOE-6CL	15.16%	No Signif.	14.70%	12.60%	26.00%	12.60%	<i>Regression by Class</i>
MCM-1CL	13.37%	17.60%	19.90%	No Signif.	No Signif.	13.37%	<i>Original Model</i>
MHC-51CL	50.81%	No Signif.	40.00%	No Signif.	No Signif.	40.00%	<i>Regression by HULL Combined</i>
LHA-1CL	19.35%	24.20%	No Signif.	No Signif.	15.20%	15.20%	<i>Regression by Class Combined</i>
LHD-1CL	8.63%	12.60%	15.30%	No Signif.	11.80%	8.63%	<i>Original Model</i>
LPD-4CL	10.74%	16.80%	17.80%	No Signif.	No Signif.	10.74%	<i>Original Model</i>
LSD-36CL	17.94%	No Signif.	18.30%	No Signif.	No Signif.	17.94%	<i>Original Model</i>
LSD-41CL	12.84%	22.60%	26.50%	No Signif.	No Signif.	12.84%	<i>Original Model</i>
CG-47CL	9.90%	14.10%	13.00%	No Signif.	15.90%	9.90%	<i>Original Model</i>
DDG-51CL	22.87%	24.50%	26.50%	8.90%	10.40%	8.90%	<i>Regression by Class</i>
DD-963CL	7.40%	21.30%	21.20%	4.40%	12.70%	4.40%	<i>Regression by Class</i>
FFG-7CL	6.72%	15.60%	16.10%	3.00%	9.40%	3.00%	<i>Regression by Class</i>
ARS-50CL	28.45%	11.90%	13.60%	No Signif.	25.60%	11.90%	<i>Regression by HULL</i>
CVN-68CL	66.83%	26.90%	N/A	No Signif.	No Signif.	26.90%	<i>Regression by HULL</i>
Pacific Fleet							
AOE-1CL	50.21%	27.20%	19.60%	No Signif.	No Signif.	19.60%	<i>Regression by HULL Combined</i>
AOE-6CL	71.47%	No Signif.	14.70%	No Signif.	26.00%	14.70%	<i>Regression by HULL Combined</i>
LHA-1CL	23.60%	No Signif.	No Signif.	14.40%	15.20%	14.40%	<i>Regression by Class</i>
LHD-1CL	10.26%	11.50%	15.30%	No Signif.	No Signif.	10.26%	<i>Original Model</i>
LPD-4CL	11.65%	18.30%	17.80%	No Signif.	No Signif.	11.65%	<i>Original Model</i>
LSD-36CL	12.41%	2.80%	18.30%	No Signif.	No Signif.	2.80%	<i>Regression by HULL</i>
LSD-41CL	18.05%	17.00%	26.50%	No Signif.	No Signif.	17.00%	<i>Regression by HULL</i>
CG-47CL	9.69%	11.20%	13.00%	16.70%	15.90%	9.69%	<i>Original Model</i>
DDG-51CL	17.38%	23.90%	26.50%	No Signif.	10.40%	10.40%	<i>Regression by Class Combined</i>
DD-963CL	11.15%	18.40%	21.20%	9.10%	12.70%	9.10%	<i>Regression by Class</i>
FFG-7CL	8.77%	No Signif.	16.10%	4.90%	9.40%	4.90%	<i>Regression by Class</i>
ARS-50CL	27.90%	No Signif.	13.60%	19.50%	25.60%	13.60%	<i>Regression by HULL Combined</i>
CVN-68CL	22.23%	N/A	N/A	No Signif.	No Signif.	22.23%	<i>Original Model</i>

Table 27: MAPE Comparison for Modified Models SR

LIST OF REFERENCES

Albright, S.C., Wayne L.W. and Zappe C., *Data Analysis & Decision Making with Microsoft Excel*. Pacific Grove, California: Duxbury Press, 2002.

Brandt, J. M. *A Parametric Cost Model for Estimating Operating Costs of US Navy (Non-Nuclear) Surface Ships*. Master's Thesis, Naval Postgraduate School, Monterey, California, June 1999.

Catalano, J.A., *Toward an OPTAR Allocation Model for Surface Ships of the Pacific Fleet*. Master's Thesis, Naval Postgraduate School, Monterey, California, December 1988.

CNO Guidance for 2003. Retrieved 5 March 2003 from <http://www.chinfo.navy.mil/navpalib/cno/clark-guidance2003.html>.

Kuker, K.L. and Craig D.H., *A Feasibility Study of Relating Surface Ships OPTAR Patterns to their Operating Schedules*. Master's Thesis, Naval Postgraduate School, Monterey, California, June 1998.

OPNAV Instruction 4100.11b (27 Sep 1989). Navy Energy Usage Reporting System. Retrieved 24 January 2003 from <http://neds.nebt.daps.mil/Directives/4100b11.pdf>.

Ting, Chu-wu, *Estimating Operating and Support Cost Models for U.S. Naval Ships*. Master's Thesis, Naval Postgraduate School, Monterey, California, December 1993.

Williams, T.D. *An Analysis of Selected Surface Ship OPTAR Obligations and their Dependency on Operating Schedules and Other Factors*. Master's Thesis, Naval Postgraduate School, Monterey, California, June 1987.

THIS PAGE INTENTIONALLY LEFT BLANK

INITIAL DISTRIBUTION LIST

1. Defense Technical Information Center
Fort Belvoir, Virginia
2. Dudley Knox Library
Naval Postgraduate School
Monterey, California
3. Professor Shu S. Liao
Naval Postgraduate School
Monterey, California
4. Professor John E. Mutty
Naval Postgraduate School
Monterey, California
5. LT Kyle Gantt
Naval Postgraduate School
Monterey, California
6. LCDR Drew Hascall
Naval Postgraduate School
Monterey, California
7. LCDR Andrew M. Matthews
Naval Postgraduate School
Monterey, California
8. 1st LT Zsolt Hajdu
Naval Postgraduate School
Monterey, California
9. CPT Mihaly Gyarmati
Naval Postgraduate School
Monterey, California