



## Calhoun: The NPS Institutional Archive

---

Theses and Dissertations

Thesis Collection

---

2002-03

# Medical planning for military operations other than [i.e. than] war: Is a paradigm shift required?

Stockton, Tony J.

Monterey, California. Naval Postgraduate School

---

<http://hdl.handle.net/10945/9791>



Calhoun is a project of the Dudley Knox Library at NPS, furthering the precepts and goals of open government and government transparency. All information contained herein has been approved for release by the NPS Public Affairs Officer.

**Dudley Knox Library / Naval Postgraduate School  
411 Dyer Road / 1 University Circle  
Monterey, California USA 93943**

<http://www.nps.edu/library>

**NAVAL POSTGRADUATE SCHOOL**  
**Monterey, California**



**THESIS**

**MEDICAL PLANNING FOR MILITARY  
OPERATIONS OTHER THEN WAR:  
IS A PARADIGM SHIFT REQUIRED?**

by

Tony J. Stockton  
and  
Joseph S. John Jr.

March 2002

Thesis Advisor:  
Second Reader:

Anna Simons  
Patricia Denzer

**Approved for public release; distribution is unlimited.**

**THIS PAGE INTENTIONALLY LEFT BLANK**

<b>REPORT DOCUMENTATION PAGE</b>			<i>Form Approved</i> OMB No. 0704-0188	
Public reporting burden for this collection of information is estimated to average 1 hour per response, including the time for reviewing instruction, searching existing data sources, gathering and maintaining the data needed, and completing and reviewing the collection of information. Send comments regarding this burden estimate or any other aspect of this collection of information, including suggestions for reducing this burden, to Washington headquarters Services, Directorate for Information Operations and Reports, 1215 Jefferson Davis Highway, Suite 1204, Arlington, VA 22202-4302, and to the Office of Management and Budget, Paperwork Reduction Project (0704-0188) Washington DC 20503.				
<b>1. AGENCY USE ONLY (Leave blank)</b>		<b>2. REPORT DATE</b> March 2002	<b>3. REPORT TYPE AND DATES COVERED</b> Master's Thesis	
<b>4. TITLE AND SUBTITLE</b> Medical Planning for Military Operations Other Than War: Is a Paradigm Shift Required?			<b>5. FUNDING NUMBERS</b>	
<b>6. AUTHOR(S)</b> Stockton, Tony J. & John, Joseph S. Jr.				
<b>7. PERFORMING ORGANIZATION NAME(S) AND ADDRESS(ES)</b> Naval Postgraduate School Monterey, CA 93943-5000			<b>8. PERFORMING ORGANIZATION REPORT NUMBER</b>	
<b>9. SPONSORING / MONITORING AGENCY NAME(S) AND ADDRESS(ES)</b>			<b>10. SPONSORING / MONITORING AGENCY REPORT NUMBER</b>	
<b>11. SUPPLEMENTARY NOTES</b> The views expressed in this thesis are those of the author and do not reflect the official policy or position of the Department of Defense or the U.S. Government.				
<b>12a. DISTRIBUTION / AVAILABILITY STATEMENT</b> Approved for public release; distribution is unlimited.			<b>12b. DISTRIBUTION CODE</b> A	
<b>13. ABSTRACT (maximum 200 words)</b> <p>Military operations other than war are increasing in frequency and, as one might surmise present unique challenges to the operational commander and the medical planner. Over time and by necessity the U.S. military has developed a logistical support system with unprecedented capability. This logistical system includes a medical system that is increasingly called upon to provide care to people outside the normal scope. Increased participation means Navy assets will be tasked to provide care to U.S. troops, U.N. troops, multinational troops, NGO personnel, and the civilians that precipitated the need for intervention in the first place. The current planning paradigm is rightfully focused on combat support. This thesis will investigate the necessity of breaking away from that paradigm when planning MOOTW.</p> <p>There is no standardized guidance, methodology, templates, matrices or even a set of guiding principles for the Navy medical planner to use when tasked with planning a medically complex contingency operation. This thesis will compare the Navy planning method with Army methods and, combined with primary source interviews, and the knowledge acquired in this graduate program, provide the reader with planning guidance unique to the medical aspects of MOOTW.</p>				
<b>14. SUBJECT TERMS</b> Military Operations Other Than War, MOOTW, Medical, Logistics, Peacekeeping, Humanitarian Intervention			<b>15. Total Pages</b> 111	<b>16. PRICE CODE</b>
<b>17. SECURITY CLASSIFICATION OF REPORT</b> Unclassified	<b>18. SECURITY CLASSIFICATION OF THIS PAGE</b> Unclassified	<b>19. SECURITY CLASSIFICATION OF ABSTRACT</b> Unclassified	<b>20. LIMITATION OF ABSTRACT</b> UL	

**THIS PAGE INTENTIONALLY LEFT BLANK**

**Approved for public release; distribution is unlimited**

**MEDICAL PLANNING FOR MILITARY OPERATIONS OTHER THEN WAR:  
IS A PARADIGM SHIFT REQUIRED?**

Tony J. Stockton  
Lieutenant, United States Navy  
B.S., Southern Illinois University, 1994

Joseph S. John Jr.  
Lieutenant, United States Navy  
M.A., Webster University, 1991

Submitted in partial fulfillment of the  
requirements for the degree of

**MASTER OF SCIENCE IN DEFENSE ANALYSIS**  
and  
**MASTER OF SCIENCE IN MANAGEMENT**  
respectively  
from the

**NAVAL POSTGRADUATE SCHOOL**  
**March 2002**

Authors:

---

Tony J. Stockton

Joseph S. John Jr.

Approved by:

---

Anna Simons, Thesis Advisor

Patricia Denzer, Second Reader

---

Gordon McCormick, Chairman  
Department of Defense Analysis

Douglas A. Brook, Ph.D.  
Dean, Graduate School of Business  
and Public Policy

**THIS PAGE INTENTIONALLY LEFT BLANK**

## **ABSTRACT**

Military operations other than war are increasing in frequency and, as one might surmise present unique challenges to the operational commander and the medical planner. Over time and by necessity the U.S. military has developed a logistical support system with unprecedented capability. This logistical system includes a medical system that is increasingly called upon to provide care to people outside the normal scope. Increased participation means Navy assets will be tasked to provide care to U.S. troops, U.N. troops, multinational troops, NGO personnel, and the civilians that precipitated the need for intervention in the first place. The current planning paradigm is, rightfully, focused on combat support. This thesis will investigate the necessity of breaking away from that paradigm when planning MOOTW.

There is no standardized guidance, methodology, templates, matrices or even a set of guiding principles for the medical planner to use when tasked with planning a medically complex contingency operation. This thesis will compare the Navy planning method with Army methods and, combined with primary source interviews, and the knowledge acquired in this graduate program, provide the reader with planning guidance unique to the medical aspects of MOOTW.



**THIS PAGE INTENTIONALLY LEFT BLANK**

# TABLE OF CONTENTS

<b>I.</b>	<b>INTRODUCTION.....</b>	<b>1</b>
A.	INTRODUCTION.....	1
B.	BACKGROUND AND OVERVIEW.....	1
C.	WHAT IS MOOTW.....	3
D.	WHY MOOTW ARE DIFFERENT FOR THE MEDICAL DEPARTMENT.....	5
E.	INCREASED FREQUENCY FOR THE UNITED STATES.....	7
1.	<i>Logistic Capability</i> .....	7
2.	<i>Media Impact</i> .....	8
3.	<i>Complex Interdependency (Globalization)</i> .....	8
F.	WHAT IT ALL MEANS TO THE NAVY MEDICAL DEPARTMENT.....	9
<b>II.</b>	<b>METHODOLOGY.....</b>	<b>13</b>
A.	RESEARCH QUESTIONS.....	13
B.	RESEARCH PURPOSE.....	14
C.	RESEARCH DESIGN.....	14
1.	<i>Problem</i> .....	14
2.	<i>Objective</i> .....	15
D.	INFORMATION SOURCES/CASE SELECTION.....	15
<b>III.</b>	<b>COMMAND AND CONTROL/CURRENT PARADIGMS.....</b>	<b>17</b>
A.	INTRODUCTION.....	17
B.	COMMAND AND CONTROL (C <sup>2</sup> ).....	18
C.	THE DOCTRINAL ORGANIZATION.....	20
D.	HEALTH SERVICE SUPPORT, THE CONVENTIONAL PARADIGM.....	26
1.	<i>The Echelons of Care</i> .....	27
<b>IV.</b>	<b>MEDICAL PLANNING SYSTEMS COMPARISON.....</b>	<b>31</b>
A.	NAVY/FMF MEDICAL PLANNING SYSTEMS.....	31
1.	<i>JOPEs</i> .....	31
2.	<i>Health Services Support (HSS) Appendix</i> .....	32
3.	<i>Comparing the Army Method with the Navy Method</i> .....	33
4.	<i>The Planning Process</i> .....	36
5.	<i>Analysis of the Army/Navy Process</i> .....	50
B.	SUMMARY AND CONCLUSION.....	51
<b>V.</b>	<b>CONCLUSIONS AND RECOMMENDATIONS.....</b>	<b>53</b>
A.	STRATEGIC CONCLUSIONS.....	53
B.	TACTICAL CONCLUSIONS.....	57
C.	SUMMARY.....	66
	<b>APPENDIX A. LIST OF MOOTW FROM 1990 THROUGH 2001.....</b>	<b>71</b>
	<b>APPENDIX B: SAMPLE MEDICAL ESTIMATE AND PLAN FORMATS—NAVY.....</b>	<b>73</b>
	<b>APPENDIX C: SAMPLE MEDICAL ESTIMATE AND PLAN FORMATS—ARMY.....</b>	<b>85</b>

<b>APPENDIX D. IMPORTANT JOINT UNIVERSAL LESSONS LEARNED AND LETTER GRANTING THE AUTHORS PERMISSION TO USE UNCLASSIFIED JOINT UNIVERSAL LESSONS LEARNED .....</b>	<b>93</b>
<b>LIST OF REFERENCES .....</b>	<b>95</b>
<b>BIBLIOGRAPHY .....</b>	<b>97</b>
<b>INITIAL DISTRIBUTION LIST .....</b>	<b>99</b>

## **ACKNOWLEDGMENT**

The authors want to thank Professor Anna Simons for her guidance, patience, and good humor during the completion of this work, but they especially want to thank her for her enthusiasm in the classroom. Further, we must thank our wives for their boundless patience, in general, and especially during the completion of this work.

THIS PAGE INTENTIONALLY LEFT BLANK

## **I. INTRODUCTION**

### **A. INTRODUCTION**

Military operations other than war (MOOTW) are increasing in frequency and, as one might surmise present unique challenges to the operational commander and the medical planner. Over time and by necessity the U.S. military has developed a logistical support system with unprecedented capability. This logistical system includes a medical system that is increasingly called upon to provide care to people outside the normal scope. Increased participation means Navy assets will be tasked to provide care to U.S. troops, U.N. troops, multinational troops, NGO personnel, and the civilians that precipitated the need for intervention in the first place. The current planning paradigm is rightfully focused on combat support. This thesis will investigate the necessity of breaking away from that paradigm when planning MOOTW.

There is no standardized guidance, methodology, templates, matrices or even a set of guiding principles for the medical planner to use when tasked with planning a medically complex contingency operation. This thesis will compare the Navy planning method with Army methods and, combined with primary source interviews, and the knowledge acquired in this graduate program, provide the reader with planning guidance unique to the medical aspects of MOOTW.

### **B. BACKGROUND AND OVERVIEW**

The demise of the Soviet Empire marked the end of an era in U.S. history. For over 40 years, President Truman's policy of containment had been the common theme in the myriad acts that comprise national security and international relations. Emanating from this policy was a complex model of the world order whereby each nation was labeled as either a First, Second, or Third World state. The First World included the U.S. and its allies. The Soviet Union and the Warsaw Pact nations constituted the Second

World. Undeveloped and underdeveloped nations comprised the Third World. Regardless of the continuing threat of nuclear war, or perhaps because of it, political affairs could be analyzed through this myopic lens.

“New World Order,” and “Global Engagement,” are new terms that have been added to the political lexicon since the Soviet Union’s implosion. Implicit in each phrase is the sense that the resulting order has changed, and that we have entered an era of unprecedented peace and stability. The first ten years of the “New World Order”, however, have been anything but stable and peaceful. The “New World Order” has been marked by increasing complexity and instability. Ethnic divisions in the Balkans and Transcaucus, tribal and religious hatred in Africa and the Middle East, plus natural and man-made disasters, have resulted in bitter warfare that has culminated in, or required intervention by, third party nations.

With the end of the cold war, Third World nations—former superpower protégés—were cut loose and set adrift to fend for themselves. Many managed to exist up to this point only through the welfare of the superpowers. With that support cut off, many have since degenerated into anarchic violence. The sequential follow-on to this statement concerns the future of the nation-state itself. Yet, whether or not the nation-state is becoming irrelevant is not particularly germane. In the present what is germane is that given “globalization” or “complex interdependence”, countries historically thought of as being outside the U.S.’s sphere of concern might, in the right circumstances, find themselves within that sphere, depending on the threat. This fact is supported by the reality that since the end of the Cold War more U.S. troops have been employed in operations to support U.S. foreign policy goals and objectives than had been employed since the ceasefire in Korea (Davis, 1998). Reviewing a list of these operations (Appendix A) quickly reveals that most of these operations have been MOOTW in one form or another. Because the frequency and scope of U.S. MOOTW since 1989 is without parallel, we must identify the peculiarities that make MOOTW unique to the Medical Department, and decide if the unique nature of MOOTW requires a critical evaluation of current planning paradigms, especially in the Fleet Marine Force.

## C. WHAT IS MOOTW

Military Operations Other Than War combines a number of unique characteristics. Some resemble war, and others appear to be so far removed from war as to call into question the appropriateness of any U.S. military involvement. Yet, in many cases the U.S. military is the only organization with the logistical capability to respond effectively.

MOOTW can be somewhat difficult to define. Do MOOTW involve combat, and is everything below the threshold of a congressional declaration of war considered to be a MOOTW? If so, can we concede Korea, Vietnam, and the Persian Gulf Wars were not wars at all but actually MOOTW? If not, what were they? Failed attempts at deterrence? If, on the other hand, the level of combat is too high to consider involvement, for instance in Korea, Vietnam, and the Persian Gulf Wars, MOOTW what is that threshold? Is it appropriate, for instance, to place Operation Sea Signal<sup>1</sup> in the same category as Vietnam? The former was a relatively benign humanitarian assistance operation and the latter a highly intense combat operation, both of which, however, could reasonably be defined as MOOTW. These are difficult questions, and deserve the attention of dedicated research, but this work will by no means answer these questions or solidify a definition. It is useful, however, to keep this ambiguity in mind when discussing MOOTW in the broadest sense. For the purposes of this work, the authors will attempt to narrow the focus in order to explore the subject with a reasonable level of detail.

We agree with the sentiment expressed in the following comment: “operations, not meant primarily to break things and kill people, unless you have to, by an organization whose primary purpose is to do just that, is very problematic” (Bonn & Baker, 2000). Though we will use the term MOOTW, we do not believe this adequately describes the range of all possible missions.

---

<sup>1</sup> Operations GTMO and Sea Signal were the Haitian/Cuban refugee interception and housing mission of 1993-1996. A combined population of 58,000 Haitian/Cuban refugees was housed on the Guantanamo Naval Base.



Figure 1. is taken from the Joint Doctrine for Military Operations Other Than War (JP 3-07, 1995). Within the block labeled NONCOMBAT we find a panoply of missions: peace enforcement, counter—terrorism, peacekeeping, noncombatant evacuations, counter—drug operations, humanitarian assistance, disaster relief, et al. For the purposes of this thesis we will use this list but will focus on those missions that tend to impact or displace large groups of civilians, e.g., humanitarian assistance, noncombatant evacuations etc., or those missions that employ large numbers of multi-national troops, when the U.S. is providing medical care, or is part of the medical system supporting the over all mission.

RANGE OF MILITARY OPERATIONS			
	Military Operations	General US Goals	Representative Examples
COMBAT	War	Fight & Win	<u>Large Scale Combat Operations</u> <u>Attack / Defend / Blockade</u>
	NONCOMBAT	Military Operations Other Than War	Deter War & Resolve Conflict
Promote Peace & Support US Civil Authorities			Freedom of Navigation Counterdrug Humanitarian Assistance Protection of Shipping US Civil Support

Figure 1. Range of Military Operations  
(From: JP 3-07, 1995, p. I-2, figure I-1)

Figure 1., is illustrative in one sense and misleading in another. Therefore, one important point must be elucidated and emphasized: these missions are not classified as war, but may still involve combat. Obviously, this is of paramount concern for the

operational commander, but should be of primary concern for the medical planner as well.

#### **D. WHY MOOTW ARE DIFFERENT FOR THE MEDICAL DEPARTMENT**

The mission of the U.S. Military is to fight and win the nation's wars. To accomplish this mission a great deal of emphasis is placed on preparing for that eventuality. Resources are expended in large quantities to recruit, train, and equip personnel to fight a conventional war.

Experience has demonstrated the need for every combat and combat support unit to possess organic medical support. Medical personnel must be trained in the medical arts and simultaneously be capable of supporting the specific mission of the unit to which individuals are assigned. To illustrate, a Navy Hospital Corpsman assigned to a Marine Crop artillery battalion must be prepared to perform his duty as a Corpsman and be mentally and physically prepared to serve as a member of a gun crew. To be effective, the Special Amphibious Reconnaissance Corpsman must be parachute-qualified, combat swimmer-qualified, and prepared to serve as either the platoon Corpsman or the communicator; if not, he is of limited value to the unit and in fact may very well become a liability. The more specialized the unit the more complex and difficult the training. Consequently, the Corpsman's medical training is very focused and, much like everyone else involved with the military healthcare delivery system, his focus, or the archetypal patient, is a 17-22 year old healthy male who, in battle, is most likely to sustain a high velocity missile injury. The Corpsman, like his superiors throughout the chain of command, is trained to deal with this type of warrior and this type of injury. Training and equipping the war fighter, the planner, and the Corpsman, to deal with the myriad needs of an eighty-year-old woman, or a two-year-old undernourished child is outside the scope of what is reasonably required to accomplish the primary mission as stated earlier.

Figure 2. (US Army FM 3-0, 2001) and 2a. illustrate the information outlined in the preceding paragraphs. Figure 2. attempts to illustrate the amount of focused effort expended in a given area across the conflict continuum. Figure 2a. is added by the

authors to further illustrate what the medical dimension might look like if it were broken out of the “support” category, and how the level of intensity, or scope of *care*, might change with the operation for reasons that include, but are not limited to, patient age, level of fitness, or general health.

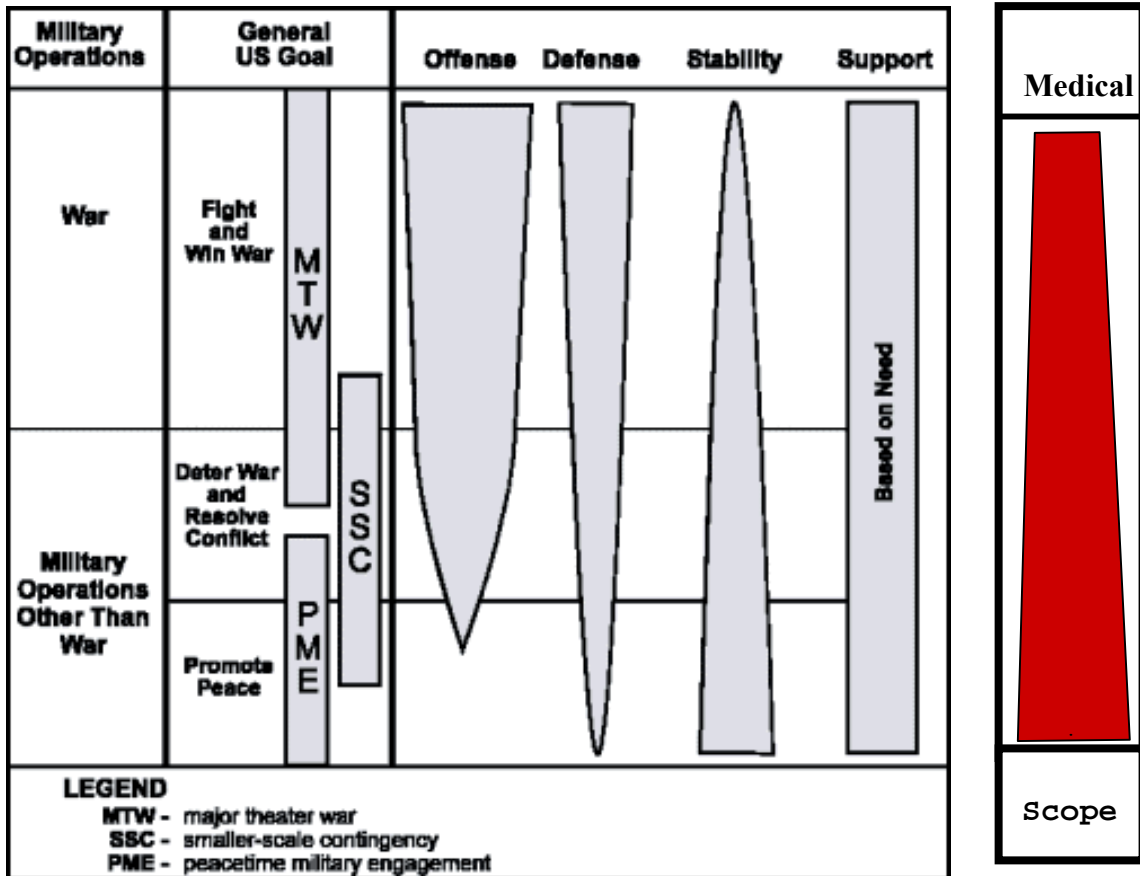

Figure 2. Range of Military Operations  
 (From: US Army FM 3-0, 2001)

Figure 2a.<sup>2</sup>

Medically, the prime mover in most MOOTW is the deployable military hospital. Deployable military hospitals are primarily surgical hospitals focused on trauma care for that same healthy young male who has been fully immunized and medically screened to assure no underlying complications. Furthermore, the objective is to either return the patient to duty or evacuate him out of the theater. The entire “echelons of care” system,

<sup>2</sup> In this case, scope is defined as patient type, versus patient census or morbidity.

not to mention the Table of Equipment (T/E)<sup>3</sup> and Table of Organization (T/O)<sup>4</sup> of all field hospitals, has been built around this concept of “degree of need” and “bed day limitations.”<sup>5</sup> Moreover, the modern military deployable hospital is stocked with consumable material to support surgical patients who will not remain in theater more than a couple of days. Field hospitals, physicians, nurses, and corpsmen are not equipped or trained to provide primary care. Nor are they equipped, trained, or staffed to provide care for chronic medical conditions.

## **E. INCREASED FREQUENCY FOR THE UNITED STATES**

### **1. Logistic Capability**

In preparation for the primary mission, the U.S. military has developed a logistical support system, the capability of which is unprecedented in history. This logistical system includes a medical support system that has been increasingly called upon to provide care for personnel outside the ‘normal’ scope. As such, the U.S. military is perhaps the only organization on earth prepared to respond quickly and appropriately to medically complex contingency operations that can range from non-combatant evacuations to large-scale, post-disaster humanitarian relief efforts. Possessing this unique logistic capability, and considering the advent of real-time news coverage, and the inherent complications of global economic interdependence, U.S. participation in MOOTW, and thus medically complex contingency operations, will likely only increase. Increased participation means DOD assets will be called upon to provide care for U.S., U.N., and multinational troops, NGO personnel, and the civilians who precipitated the

---

<sup>3</sup> The Table of Equipment or T/E as it is more commonly called, is an established list of equipment required for a particular unit type to accomplish its assigned mission.

<sup>4</sup> The Table of Organization or T/O, is an established list of personnel required for particular unit type to accomplish its mission. This list delineates the personnel requirements by job skill, not by name.

<sup>5</sup> The echelons of care, and theater bed day limitations, are discussed in more detail in Chapter Two. Suffice it to say, a limitation is placed on the number of days a patient can occupy a field hospital bed before requiring medevac out of theater.

need or intervention in the first place. Very few of these people can be counted upon to have been fully immunized or medically screened. Nor can they be relied upon to possess comprehensive medical records.

## **2. Media Impact**

The dawn of the information age has had a dramatic impact on the way decisions are made by those in power. Media coverage of the Vietnam War foreshadowed the media's subsequent role, with which we are now familiar. Walter Cronkite's nightly body counts, with still photographs of dead soldiers in the background, paved the way to real-time or near real-time video coverage of events as they occur around the globe. During the war in Iraq for instance, citizens of the world could sit in their living rooms and watch real-time bomb footage. Often times civilians thousands of miles removed watched the video before the intelligence officers in-country were able to make bomb damage assessments. CNN coverage of real-time events is so pervasive that almost everyone has a television in his or her office that is tuned to the news channel, and this includes members House and the Senate.

The media's impact is immeasurable. Can anyone argue that pictures of starving children in Somalia did not play a part in the decision-making process that put U.S. troops on the ground there? Furthermore, can anyone argue that the video of dead American soldiers being dragged through filthy streets played a part in our hasty withdrawal? Media coverage is very selective, and selection can be driven as much by the importance of the story as by whether a reporter is in the area. The newspaper space and television time dedicated to events in Somalia versus Liberia, Angola, or Rwanda bear no relation to the size or scope of the tragedy in any of these countries. Once a selection is made, the coverage is usually very intense, but of a very limited duration, and it is this level of intensity that can have the effect of driving policy.

## **3. Complex Interdependency (Globalization)**

Interdependence among countries has evolved to a level that rivals power, or "high politics," for dominance in world affairs. The world has changed since the time of

Yalta and Bretton Woods. Small nations with relatively limited military power, but with sizable economies and military/economic/diplomatic/security relationships with other interdependent nations, speak with a much louder voice than in 1945 (Keohane & Nye, 1989). Paul Kennedy (1989) stated that specialization, the very thing that made the nation-state possible, has grown to a point that nation-states are increasingly reliant on each other for their overall economic well-being and their security. Keohane and Nye (1989) do not discard the idea of the pursuit of self-interest, but point out that the pursuit requires cooperation among states in order to achieve success.

It may be more illustrative to say the current international system functions like a spider web. A mis-step or movement of any kind, by any actor, regardless of his position on the web, can be felt, and more importantly, have an impact at the center, as well as in the peripheries.

As the reality sets in that poor outcomes at the conclusion of most crises can have a poor or destabilizing impact on nations a world away, the likelihood that the U.S. will be called upon to intervene will increase concurrently. Intervention will take on a number of possible flavors and thus involve the DOD Medical Department in ways contrary to accepted doctrine.

#### **F. WHAT IT ALL MEANS TO THE NAVY MEDICAL DEPARTMENT**

The increased frequency of U.S. involvement in MOOTW has spurred debate about the future role and mission of the U.S. military. There are essentially three arguments framing this debate. First, the U.S. military has no business engaging in any operation where the application of military force is not employed specifically to defeat a credible enemy. Second, the focus of the U.S. military should shift to MOOTW. Embedded within this argument is the idea that, at a minimum, a specialized command should be formed specifically to support the more benign MOOTW, e.g. humanitarian relief and peacekeeping. Third, we should stick with what we know, that is, prepare for war, but also be prepared to use the instruments of war to support MOOTW (Bunker, 1995).

Like the debate over the future of the nation-state, the first two arguments are not the focus of this work and, with the exception of some minor command and control structural changes mentioned in chapter II, neither will be discussed in any detail. The third argument of the debate, however, is integral, since preparing for war and preparing for humanitarian assistance are mutually exclusive as far as the DOD medical department is concerned.

General support for organic troops is not comparable to support for a malnourished two-year-old, or a demented 80- year-old. This presents a unique problem, not just for the medical department, but also for all those charged with the efficient and effective deployment of the DOD as a whole. Compare and contrast the two major regional conflict (MRC) scenario with those missions that we tend to define as MOOTW. The cost of preparing to fight two MRC's is extreme, but has been accepted as the cost of preserving our nation's freedom. It is considered cheap if aggressive behavior by other states can successfully be deterred. Compare that with the costs of not being prepared and being forced to fight for our survival as a nation. As long as we prepare, the likelihood of the two MRC scenario becoming reality is low. Contrast this with the greater probability that U.S. forces will be engaged in MOOTW. The consequences of not being specifically structured and trained for MOOTW are not nearly as costly, and do not have the same long term consequences. So, while the MRC can be considered a high cost, low probability venture, MOOTW are a high probability, low cost venture (when compared to conventional theater warfare), and the cost of not preparing for MOOTW is nothing compared to the cost of being ill-prepared but forced to fight two MRC's. For DOD medicine the dilemma is even more complicated. Medical training for war entails moulage and mannequin, (using fake wounds and fake bodies, respectively). Active participation in MOOTW usually involves real blood and real people, the best possible training for the MRC scenario. So, while the war fighter sees MOOTW as a drain on readiness, the medical support element might consider MOOTW to be a unique training opportunity.

An examination of Navy and Fleet Marine Force medical C<sup>2</sup> systems reveals that the U.S. Navy Medical Department has no single source of historical information about these types of missions. Nor does there appear to be standardized guidance, methodology, templates, matrices or even a set of guiding principles for the medical planner to use when tasked with planning support for medically complex contingency operations. This is significant because in most crises the medical planner tasked with the initial planning, with preparing his people, gathering supplies, and finally, executing a medically complex contingency will have little or no prior experience and no formalized training to draw upon in a MOOTW environment. More importantly, until recently the Navy medical planner could use the FMFM 4-50 (Health Service Support) as a guide for planning medically complex contingencies. The FMFM 4-50, inadequate as it was, was better than nothing. However, it has since been superseded by Marine Corp Warfare Publication (MCWP) 4-11.1 (Health Service Support Operations), which the authors, not to mention a number of other experienced medical planners, consider woefully inadequate for planning combat support, but absolutely useless for planning anything else, especially MOOTW. Later in this work we will argue that the FMFM 4-50 needed to be expanded upon to include specific guidance on medically complex contingency operations, but it should not have been watered down to a “Cliff Notes” version. We believe that the MCWP 4-11.1 falls well short of its purpose and is nothing more than a well written overview of operational medicine.

Thus, an informed reader may well question the relevance of a large portion of this thesis, that is, since we compare the outmoded FMFM 4-50 with the Army’s FM 8-55 (Planning for Health Service Support). However, we believe this comparison is justified since FMFM 4-50 could be easily updated and expanded and would thus be far superior to MCWP 4-11.1 which offers nothing by way of useful comparison with the FM 8-55.



**THIS PAGE INTENTIONALLY LEFT BLANK**

## **II. METHODOLOGY**

### **A. RESEARCH QUESTIONS**

First, our purpose is to determine if MOOTW place unique demands on the Navy medical department. Second, if MOOTW are unique, does the unicity demand a paradigm shift to something different from the currently accepted planning process, namely, the five paragraph method, alluded to in MCWP 4-11.1 and fully detailed in FMFM 4-50? Third, given the U.S. Army's experience in MOOTW, can a detailed comparison of the Navy and Army planning methods, combined with input from experienced planners and a thorough review of the lessons learned, produce an alternative, or enhance the current method that recognizes the unicity of MOOTW for the Navy medical department?

Ironically, the preceding paragraph is nothing like our intended opening paragraph. Initially, our intent was to determine whether it would be possible to build a new and comprehensive planning format for Navy medical planners by comparing specific MOOTW cases. Second, we wanted to evaluate cases that were predominantly planned and executed by the U.S. Navy to determine whether Navy operational medical assets could be utilized more effectively by applying or adapting the methods utilized by U.S. Army medical planners? However, after an exhaustive search of available, unclassified, reference sources we found that there was not enough detailed information available to draw any useful conclusions. The number of formalized lessons learned that focused on the medical aspects of MOOTW are extremely limited. Further, the availability of primary source historical data is likewise problematic. Command histories and situation reports pertaining to the medical aspects of recent cases we intended to investigate were either non-existent, or were archived and may as well have been non-existent. At this point the critical reader may be asking why this is important. It is important for making another, and maybe the most important point, that is, if historical

information detailing the medical aspects of virtually all real-world operations is so limited as to be non-existent then, it is *of no help to anyone*. Once the mistakes and the hard lessons learned by those with experience have been lost, we are, at best condemned to go through the same pain again, and relearn many of those same lessons. The aim of this thesis is to reverse this trend and redress the gap.

## **B. RESEARCH PURPOSE**

The purpose of this thesis is to:

- Develop a thorough understanding of accepted medical planning procedures, techniques, and/or methodologies used by the U.S. Army to determine if they can be applied or adapted to assist the Navy medical planner.
- Develop a historical perspective on medically complex contingency operations through case studies, interviews with primary sources and an exhaustive review of the germane literature.
- Provide recommendations for improving the medical planning process.
- Provide a method, template, or a set of guiding principles to facilitate better planning, and hence more effective utilization of Navy medical assets in the future.

## **C. RESEARCH DESIGN**

### **1. Problem**

Each time a medically complex contingency arises the planner initiates and moves through the planning process without being able to tap into either a centralized repository of historical data or an established planning method unique to MOOTW to begin the planning process. In many instances, the medical planners are untrained and lacking in

operational experience. The concept of providing appropriate medical care to large, diverse groups of people in adverse conditions will be foreign to them. In many cases, the operational commander—the person ultimately responsible on the ground—will lack the background or experience to anticipate the myriad needs of a physically diverse civilian population or the needs of multinational participants .

## **2. Objective**

Our objective is to compare U.S. Army planning guidance with Navy guidance to determine whether the Navy method could be enhanced by adapting or synthesizing Army methods. Also, we will use what data is available to discern the common problems experienced across a range of operations and document those problems. Lastly, we will apply what we have learned in this graduate program about the impact of culture on group behavior in adverse situations, and match that with the experience of the authors and others who have participated in MOOTW to compile a list of questions or guidelines that a planner might use either to gather intelligence to write a plan or to avoid problems in execution.

## **D. INFORMATION SOURCES/CASE SELECTION**

Service-specific and command “lessons learned” databases, ad hoc (JTF’s) command histories, and periodic situation reports (SITREPS) have been located, and though limited, they have been researched and mined for pertinent data, and whenever possible primary sources have been located and interviewed.

Case selection was based primarily on data availability with the focus more on the type of mission than the specific operation, e.g., humanitarian relief, or refugee care.

Certainly, one could make a reasonable argument that every MOOTW is so absolutely unique that it is impossible to draw broad conclusions, and consequently useless to make meaningful recommendations. However, the authors believe that even taking into account the unicity of each case, they still present common problems to medical planners.

For instance, cases, regardless of cause, that resulted in large populations being displaced and eventually housed in refugee camps, constitute one broad category of MOOTW. Non-Combatant Evacuations (NEO's) represent another. On the surface, post-disaster relief can be somewhat difficult to categorize as the medical needs differ depending on the type of disaster e.g., earthquakes tend to produce a great deal of physical trauma, whereas hurricanes usually do not produce a lot of trauma victims, but do require a great deal of primary care and preventive medicine effort (Weddle, May 2000). Nevertheless, we believe there are enough similarities among refugee support, NEO's and disaster relief missions to categorize them under what will henceforth be called HA (Humanitarian Assistance). Similarities with other MOOTW missions will surface throughout this thesis.

Finally, numerous authors are cited throughout this thesis, and are therefore properly credited whenever we refer to their work, in the reference section. However, in our attempt to research specific cases and learn as much as possible about MOOTW and especially the medically unique aspects of MOOTW we read many authors whose combined works influenced our thinking. We include their books, articles, and reports in our bibliography, although they may not be specifically cited in the body of this thesis.

### **III. COMMAND AND CONTROL/CURRENT PARADIGMS**

#### **A. INTRODUCTION**

To plan the medical portion of a MOOTW effectively, it is essential that the planner appreciate the fundamental nature of medical planning and its relationship with policy making, national strategy, and operational planning. The medical plan cannot be conceived of, or written, in isolation. The medical planner must incorporate the goals of both the policy makers and the operations commander. Chapter I discussed the reasons MOOTW are, and will continue to be, an important aspect of our nation's strategic interest, and therefore the military's focus. Further, in Chapter I we discussed the influence that periphery organizations or systems can have on policy making and strategy execution, e.g., the media and NGO's. In this chapter we intend to narrow the focus and concentrate on the operational level of planning and where the medical department fits into the larger operational picture. Then we will begin to show the reader how MOOTW, because of their size, scope, unicity, and the tendency toward isolation, break down accepted doctrinal paradigms beginning at the systemic level.

According to Marine Corps Doctrine Publication 5 "Planning" (MCDP-5, 1997), "planning is an essential and significant part of the broader field of command and control...planning constitutes half of command and control, which includes influencing the conduct of current evolutions and planning future evolutions" (p. 8-9). The same manual goes on to describe planning as "anticipatory adaptation" good words, but as this chapter will demonstrate, adaptation is not the norm within the larger organization, and is made even more difficult for the medical department given the fact that the military medical system is designed around a hierarchal process (echelons of care) that does not exist in MOOTW.

## **B. COMMAND AND CONTROL (C<sup>2</sup>)**

As outlined in Chapter 1 the prime mover, medically speaking, in MOOTW and especially in HA operations, is the field hospital. There has never been a circumstance that we can find where a field hospital, Army, Navy or Air Force, has acted independently. In each case, the field hospital was subordinate to a Joint Task Force Commander. NEO's are usually not sustained operations and therefore do not employ field hospitals, but usually will employ the bulk of the medical assets organic to a Marine Expeditionary Unit (MEU). In the case of the latter, the chain of command is the standard FMF structure. The planner should know the chain and not expect that any adjustments will be needed or considered. In the case of the former, however, the medical planner will not necessarily know how the chain of command will look. Nor will he know where medical's place in the chain will be. Therefore, some knowledge of the possibilities is required.

The Joint Staff Officer's Guide (JFSC Pub 1, 2000 p. 1-45-53) describes and illustrates a model for the Joint Task Force. The emphasis in the manual is on the joint aspects of the organization, not its function. This is reasonable for two reasons. First, the focus of the manual is war fighting (as it should be). Second, the Goldwater-Nichols Department of Defense Reorganization Act of 1986 changed the organizational paradigm of each service and, because of this, a great deal of emphasis is placed on building a coherent and hence functional chain of command, especially in contingency situations. Nonetheless, the majority of the missions that have employed the personnel and the material assets of Navy operational medicine are classified as "Military Operations Other Than War," and while the majority of these operations have been "joint," the real mission was functional, hence the term "task" force. Yet, while the doctrine suggests flexibility from the outset, in reality the organizational structure seldom changes as a function of the mission.

The Joint Staff Officers Guide (2000 p. 1-49), illustrates what is essentially a standard organizational chart that places the Command Surgeon in a position separate

from the Joint Staff. This is a little different from the normal military bureaucracy, and while it looks good on paper, it is not what occurs in reality. In actuality, the Joint Task Force Surgeon is placed in a subordinate position to the J4 (Logistics section) since the delivery of healthcare is considered a service, and therefore a logistical function.

A reasonable argument can be made that in most MOOTW missions, and HA especially, as described in Joint Publication 3.02 (Doctrine for Joint Operations 1995), the JTF organization should reflect the function and the natural evolution of the operation, that is, certain elements of the organization should evolve as the mission evolves. One example, although not the only one, is the JTF Surgeon. If he is not placed in a direct subordinate position to the JTF Commander, he could be assigned to the J3(Operations section). As the mission progresses the medical portion will evolve to one of the primary functions of the entire task force (Davis, 1996).

The delivery of healthcare in MOOTW can become a vital part of the ongoing operation, and as such means medical services tend to operate as a J3 asset instead of just another service delivery organization. This is particularly true when medical screening will be used as a determining factor for a refugee's future.

For instance, during the Cuban/Haitian refugee situation (Operation Sea Signal), the refugees were housed on the Naval Base at Guantanamo Bay. Initially, the only refugees that were going to the U.S. were those in need of medical attention that could not be provided in Guantanamo. When an individual needed to be medevaced, the patient's entire extended family would be transported to the U.S. as well. As one can imagine, this became the most direct way out of the refugee camps, and therefore a popular method of emigration. Later, when the Department of State decided that all the Cuban refugees would be allowed to emigrate to the U.S., with the level of migration limited to 500 per week, the sick, injured, and pregnant were the first to go (along with their families). Naturally, being afflicted became an advantage, particularly when the 500 per week limitation meant that some people namely, the non—afflicted, could expect a two-year wait in the camps en route to the U.S.



A reasonable argument could be made that neither the C<sup>2</sup> structure nor the lack of a formalized medical planning system will determine success or failure of a MOOTW. When one considers the political and media pressures usually associated with MOOTW, effective—efficient medical operations should be a primary concern.

The U.S. Navy has no single source of historical information about this type of mission. Moreover, except for the Health Service Appendix to the OPLAN, and a small portion of Joint Operation Planning and Execution System (JOPES), there is no standardized guidance, methodology, templates, matrices, or even a set of guiding principles for the medical planner to use when tasked with planning support of a medically complex contingency operation, thus, no embedded C<sup>2</sup> medical system. As mentioned earlier, in most crises, the medical planner tasked with planning and executing a medically complex contingency will have no prior experience or formalized training to draw upon in an HA operation. For example, the Medical Service Corps officer (MSC) assigned to an air craft carrier and the MSC officers assigned to amphibious ships are patient administration officers, not Plans, Operations and Medical Intelligence Officers (POMI).

### **C. THE DOCTRINAL ORGANIZATION**

As mentioned earlier, JFSC PUB 1 (2000) provides a section dedicated specifically to the Joint Task Force (JTF). The emphasis in the narrative in this section is on joint structure, not command's function or task. In this particular publication this is appropriate since, as a "Joint Staff Officers Guide", the structure is paramount and it would be virtually impossible for this document to illustrate all the permutations of the JTF command structure for the myriad missions that it might be formed to support. This point is emphasized by the statement that "Positions on the staff should be divided so that Service representation and influence generally reflect the Service composition of the force" (JFSC Pub 1, p. 1-45, 2000).

However, consider the futility of this statement if the JTF Commander were to follow this guidance to the letter. He or she would construct a staff organization that

quite probably would not function in a manner commensurate to the task. Consider the tremendous logistical transportation needs presented by a refugee camp scenario. If there are numerous small camps comprising the entire enterprise, efficiency and use of limited resources will mandate that many of the services required by the refugees be centrally located. Therefore, moving refugees from one camp to another would require a large number of truck drivers. Since the Army possesses the largest number of trucks and drivers, they compose the largest cadre on the JTF. If the JTF commander follows the guidance of the JFSC Pub 1 then an Army Officer would be the J4. What if the main focus of the JTF were stevedore and security operations being handled by Marine Corps and Air Force assets? Both the stevedore and security missions in this case are more important than inter-camp transportation. Because these two services are divided between two branches, neither the Marines nor the Air Force comprise a majority of the personnel providing logistical support. Neither service then would be represented appropriately on the staff (commensurate with their task), according to the JFSC Pub 1. Thankfully, the authors of JFSC Pub 1 offer the JTF Commander the latitude to organize the staff as he or she deems necessary.

Figure 3. is the recommended example of the JTF Organization from JFSC Pub 1 (2000). Note that the Surgeon is listed as a “Special Staff Officer.” This is the typical location for the Surgeon within the organization chart for both JTF’s and the common Fleet Marine Force staff organization, but it does not represent the reality in most instances. From personal experience, and that of the other officers interviewed for this work, the Surgeon is usually placed in a subordinate position to the J4.

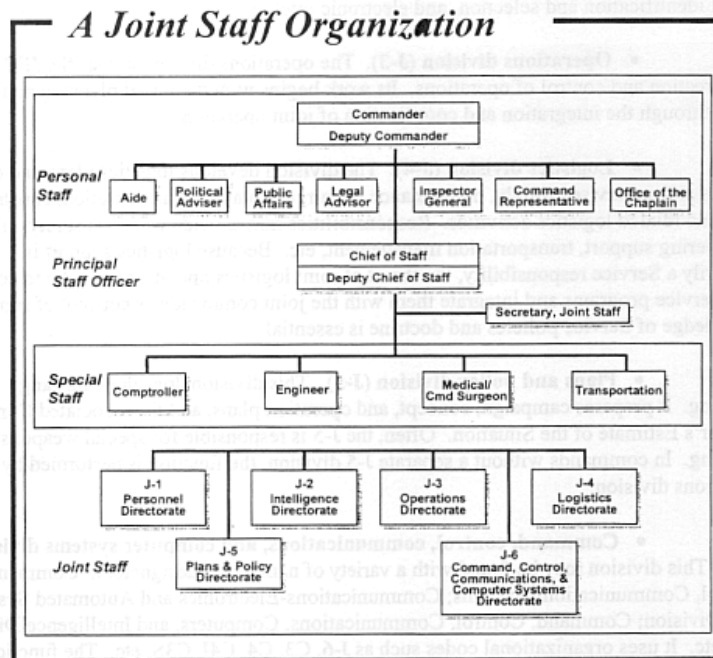

Figure 3. Recommended Joint Staff Org.  
(From: JFSC Pub 1, 2000)

As part of this thesis, and in support of this Chapter, we interviewed three Medical Planners and one Marine Infantry Officer<sup>6</sup>. Two were planners in Cuba (GTMO/Operation Sea Signal), and the third planner and the Marine were in Haiti (Operation Fair Winds). In each case, they confirmed that the Command Surgeon began the operation subordinate to the J4 (E.Saenz, G. Trotter, R. Brown, & W. Nemeth, personal communication). For JTF 160 (Operation Sea Signal) this was the case but the position migrated to the J3 or the “personal staff,” as depicted by Figure 3. The changes or migration occurred for two reasons. First, the mission evolved to a point that the medical department had become a day-to-day player in the operation with an impact on the outcome of operations planned and executed by the J5 and J3 respectively (E. Saenz, personal communication, 16 August 2001). Second, the Task Force Commander changed

<sup>6</sup> The Marine Infantry Officer was the Combat Service Support Group Commander and therefore responsible for a large portion of the FMF medical asset in Haiti.

and the new Commander desired a direct line to the Surgeon and visa-versa (G. Trotter, personal communication, 31 July 2001).

For Operation Fair Winds, the men interviewed agree that U.N. involvement complicated C<sup>2</sup> to such a degree that at times the chain of command was nonexistent. In both cases, the men stated that the chain of command differed depending on the issue at hand. For example, the U.N. CJTF Commander was an American Army General; for medical issues dealing directly with U.S. forces, or civilian relief agencies, the Command Surgeon dealt with the J4. For medical issues involving the care of Haitians, international G.O.'s, or N.G.O.'s the Surgeon was a functional staff officer. The difficulties arose when no one could decipher who the patient in question worked for (R. Brown & W. Nemeth, personal communication, August 2001).

Fleet Marine Force Manual 7-16, "Multiservice Procedures for Humanitarian Assistance Operations" provides what it calls a notional example of the JTF command structure, specifically for Humanitarian Assistance Operations. This manual places the Surgeon in a subordinate position to the JTF Support Command element (see figure 4.). FMFM 7-16 does say, "The nature of HA [Humanitarian Assistance] may require a JTF to be tailored so that combat support (CS) and combat service support (CSS) forces (CA, engineer, medical, logistics) may have an equal or greater role than other assigned units" (p. 4-0). Again, this may be the recommendation in the narrative, but Figures 3. and 4. illustrate something different, and experience demonstrates something different still.

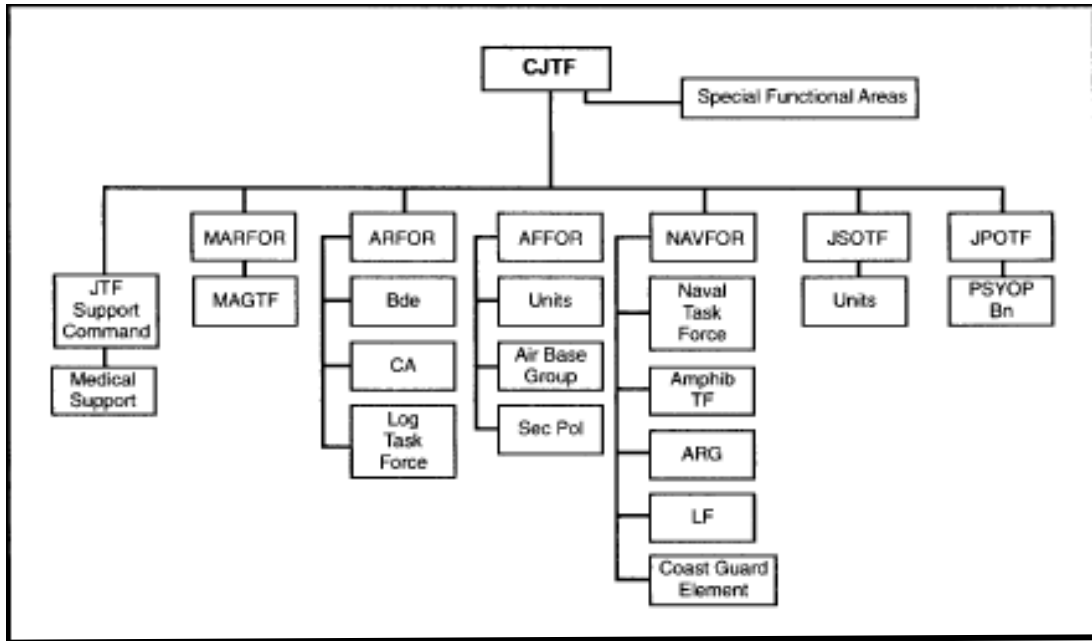

Figure 4. Recommended HA Staff Org.  
 (From: FMFM 7-16, October 1994)

The literature review and primary source interviews demonstrate that universal agreement on the organizational structure for a JTF or Combined JTF for MOOTW does not exist. Furthermore, while there is a lack of mutual agreement on the structure, the primary source interviews indicate that most Commanders are unable to initially break out of the traditional C<sup>2</sup> paradigm. However, the individuals interviewed indicated that as the mission evolves over time, JTFC's tend to recognize that a different structure is required if they are going to be effective in all aspects of the mission, i.e., providing the necessary services, dealing with media, and, more importantly, the politicians.

No single C<sup>2</sup> organization option works best for all MOOTW. JTFC's and their subordinates should be flexible in modifying standard arrangements to meet the specific requirements of each situation and promote unity of effort.

Below is a direct quote taken from the lessons learned from a training exercise. It, combined with the description of the command structure in Haiti outlined above, should serve to illustrate to the reader and medical planner the problems encountered by

the medical asset and the confusion caused by ambiguous or non-functional chains of command.

Observation:

During the middle planning conference, and again at the final planning conference, the issue of where the Combined Medical Treatment Facility (CMTF) would be placed organizationally, ADCON or OPCON was unclear.

Discussion:

It was determined at the MPC [middle planning conference] that the CMTF would fall under the administrative control of the Camp Commandant for non-medical related concerns, and fall under the command of the senior Australian Defense Force Medical Officer (ADF)(OPCON). Additionally, the CJTF Surgeon, as the principle medical/dental advisor to the Commander, exercises directive authority over medical/dental/veterinary resources in the Task Force...For their part, the Australian Defense Force reflected in their Health Service Support Plan (Exercise Tandem Thrust) that the Combined AS/US Medical Treatment Facility at Sam Hill was under the command of MARFOR. COMMARFOR Health Service Support personnel were under the impression that the CMTF would be under the professional control of the Commanding Officer ADF O-5.... (JULLS Number 94877-84741 (Active) Unclassified, used by permission, see Appendix E. )

This quote is an excellent example of what happens in the “real world,” as opposed to what the doctrine says should happen. Medical planners should be aware that this type of confusion is the rule, not the exception. Further, medical planners should realize, as did the person who penned this lesson learned, many commanders treat their

medical assets as a side show, one that they would rather not have to bother with unless or until it becomes politically fitting. Subsequently, in order to render this command relationship workable, the planner and the Surgeon will have to be vigilant and vocal from the outset.

#### **D. HEALTH SERVICE SUPPORT, THE CONVENTIONAL PARADIGM**

To fully appreciate the uniqueness of MOOTW for the medical department one must first gain an understanding of the wartime structure and the ‘echelons of care’ concept. This understanding will begin to demonstrate how the military medical system, and therefore the planning paradigm begins to breakdown in MOOTW.

The Navy’s wartime health service support system is structured to provide the care required as close to the “forward edge of the battle area” (FEBA) as possible. That is, no casualty should be medevaced further rearward than is necessary. The medical department’s foremost mission is to return the war fighter back to duty as quickly as possible. This mission must be accomplished with the understanding that there will always be limited bed space available for patient recovery in the theater of operations. Bed space is not only limited by the unit’s size, but also by the need for the medical unit to be as mobile as is the fighting organization it is supporting. Further, patient care is a twenty-four hour a day job, and field hospitals are not staffed to support long term care. Therefore, a trade-off must be made in the decision process as to the level of treatment any casualty might receive in-theater. A Marine may be expected to fully recover from his injuries, but his recovery may take a number of weeks. In a case like this one it may seem appropriate to keep the Marine as close to the FEBA as possible. In fact, the bed space limitations will require that the Marine be medevaced rearward to recuperate, even when his return to duty is imminent. The system, with its embedded echelons of care, is supposed to be fully integrated from the combat zone all the way back to facilities within CONUS.

## 1. The Echelons of Care

Health service support in a theater of operations is broken down into levels which connect the combat zone (echelon I) with the major medical facilities in either the continental U.S. or Europe (echelon IV or V). The capabilities at each level are designed to deliver a progressively higher level of care, and each higher level, or echelon, must be able to deliver the same level of treatment as the echelon closer to the FEBA, but add new capabilities the further rearward one goes. Each echelon is limited by the factors discussed in the last paragraph, i.e., patient's needs, unit mobility, capability, staffing, and bed day limitations imposed by higher authority.<sup>7</sup>

Combat casualties are medevaced rearward through the system until they arrive at a facility capable of rendering the care needed. The determination is made solely on patient needs and unit capability, with the other limiting factors not being considered until the patient is stabilized. The echelons of care are summarized below:

- Echelon I-The unit hospital corpsman, and the Battalion Aid Station. Corpsman aid is not limited to emergency or lifesaving care. It can include care for illness or injury and might include minor surgery. Echelon I also includes the care rendered at the Battalion Aid Station (BAS), and represents the first time an injured person can be evaluated by a physician.
- Echelon II-This level of care possesses a surgical intervention capability, ancillary support,<sup>8</sup> and a limited number of ward beds. Echelon II usually represents the last level of care that can be rendered in close proximity to the combat zone. This is the level of care usually delivered by either a Collecting and

---

<sup>7</sup> Bed day limitations are properly termed "Evacuation Policy." The upper limit is imposed by the SECDEF. The theater commander is authorized to reduce the number, as are subordinate commanders. However, they are not authorized to increase the number. Nor do medical personnel have the authority to alter the limitation. This is an upper limit; it should not be misinterpreted. Patients should be medevaced rearward as soon as the need is determined.

<sup>8</sup> Ancillary support consists of laboratory, X-ray etc.



Clearing Company and/or a Surgical Company. Further, Casualty Receiving Ships (CRT's) are echelon II assets also.<sup>9</sup>

- Echelon III-This is the level of care to be rendered by a properly equipped/staffed hospital. It is usually delivered by either a Fleet Hospital or a Hospital Ship,<sup>10</sup> and it is usually located in a low threat environment, and lacks the mobility to move with the forward edge of the battle area (FEBA). This is usually the first step toward restorative care.
- Echelon IV-Definitive medical care. Usually delivered at fixed facilities located outside the theater of operations.
- Echelon V-Convalescent, restorative, and rehabilitative treatment, at CONUS military or veteran affairs facilities.

This discussion is important given that within MOOTW the echelons of care will not exist to support the medical unit in theater. Since this concept is the foundation of Navy-FMF operational medical support, and hence the T/E and T/O of the MOOTW designated unit are built on having that echeloned support structure in place, it is imperative that the operational commander-planner, and especially the medical planner, be aware of the inherent limitations when an echelon II or III unit is deployed to a MOOTW by itself.

Unlike the U.S. Army or Air Force, the U.S. Navy and Marine Corps do not possess dedicated air medical evacuation assets. Air-evac's are executed by "lift of opportunity." An injured or sick Marine/Sailor will not be air-evaced unless the "bird" was already headed in the right direction and there was room for the patient and the

---

<sup>9</sup> A Collecting and Clearing Co. is comprised of 2 operating rooms and 60 ward beds. A Surgical Support Company has 5 operating rooms and 150 beds. Both units are organic to the Medical Battalion of the Force Service Support Group; both are staffed by Navy medical personnel, but are strictly Marine Corps assets. Casualty Receiving Ships must not be confused with Hospital Ships. CRT's are Amphibious Assault Ships that are converted to receive casualties after the embarked Marines have gone ashore.

<sup>10</sup> These are Navy assets under the control of the regional CINC.

attendant. Navy and Marine Corps aircraft will not be earmarked for medevacs unless a qualified attendant is readily available.

Ground transport is organic to echelon II and III units, but in limited numbers. A Collecting and Clearing Company, for example, has but six ambulances within its T/E. The medevac system under the echelons of care concept requires the rearward medical unit to move forward to “collect” casualties; a unit closer to the FEBA should never move casualties rearward from its own position.

This systemic breakdown extends even further when one considers that the consumable medical resupply system works essentially the same way. Resupply efforts are accomplished by a medical logistics company via the ground medevac system. And again, unlike Army units, FMF units do not have personnel versed in logistics on the T/O.

Therefore, in most MOOTW situations, FMF medical units that were never designed to act independently are expected to do just that.

**THIS PAGE INTENTIONALLY LEFT BLANK**

## **IV. MEDICAL PLANNING SYSTEMS COMPARISON**

### **A. NAVY/FMF MEDICAL PLANNING SYSTEMS**

There are two primary planning systems utilized by the Navy medical planner: the Joint Operation Planning and Execution System (JOPES), and the Health Service Support Appendix to the OPLAN found in FMFM 4-50<sup>11</sup> (p.7-5, C-1, D-1, 1990). Each is helpful but inadequate for assisting the planner in MOOTW because, as with the C<sup>2</sup> discussed earlier in this chapter, both were designed to support war planning.

#### **1. JOPES**

The medical module of the JOPES is purely logistical in make-up. The process of using JOPES in medical planning, however, is not meant to assist the medical planner, but to support the process of operational planning. Essentially, when the medical planner uses the medical module of JOPES he answers a set of predetermined questions that will eventually help decide the lift requirement for the medical support involved in the mission. Embedded in JOPES there exists a database with all of the “Authorized Medical Allowance Lists” (AMALS). Using this as a base line, the JOPES application presents the operator with a series of questions to determine which AMAL is most suitable for the current situation. What’s more, every organization in the military is built and equipped following the T/E and the T/O specific for that unit, and this includes medical organizations. To help clarify: the T/E is a list of the organic equipment for a unit and the AMAL lists the consumable material the organization might require in a given mission. The JOPES application, through user query, helps determine the weight and cubic feet of the medical material needed for the mission. Further, it will query the user on the changes or shortages of both equipment and personnel, feed that data into the

---

<sup>11</sup> Although the FMFM 4-50 is out of circulation, it houses the same planning format that the MCWP 4-11.1 only refers to, but does not detail nor does it provide example of finished plans or estimates.

Time Phased Force Deployment Data (TPFDD) module and help produce the OP or Campaign plan, while simultaneously informing TRANSCOM as to the lift requirements. The result, however, is a product that assists planning outside the medical organization. The real conceptual work has to occur *before* the user inputs the TPFDD. In order to answer the queries appropriately the planner must have already determined what the needs of the mission are. He must have already gathered data on the potential enemy, terrain, weather, personnel outside his own unit that he will likely be treating, endemic diseases, dangerous vectors, etc. Therefore, calling the medical module of JOPES a medical planning tool is only partially correct.

## **2. Health Services Support (HSS) Appendix**

The Health Service Support Appendix to the OPLAN is the primary planning tool endorsed, and used by, the Navy medical planning community. The premier doctrinal manual, historically considered the “bible” for Navy field medicine, is the FMFM 4-50 (1990). Chapter Seven, HSS Planning, introduces the concept of the “five paragraph OPLAN.” The five paragraph OPLAN consists of sections headed: Situation, Mission, Execution, Administration and Logistics, and finally Command and Signal. Essentially, the idea is to fill in all the information you possibly can under each of the headings and you will produce the Health Service Appendix to the Logistics Annex of the standard NATO planning document. FMFM 4-50 (1990) provides a template and an example of what a proper HSS Appendix looks like, and both are reproduced for this thesis in Appendix B. This is an excellent document to use when preparing for combat. It truly is an indispensable adjunct to planning for combat support missions. However, it does little to assist the inexperienced planner. Nor does it assist planning for MOOTW, especially HA.

The guidance provided by FMFM 4-50, just as with most other doctrinal manuals, is written within the conventional combat paradigm. FMFM 4-50 assumes that Health Services will be provided solely to organic personnel and that the medical T/E&O, and organic AMAL, will suffice in supporting the operation, and that they will function as

part of the integrated medical care system (echelons). Interestingly, neither JOPES nor TPFDD are mentioned anywhere in FMFM 4-50. These are the two primary sources for medical planning and neither refers to the other. The MCWP 4-11.1 does refer to JOPES, but as usual does it without elaboration.

### **3. Comparing the Army Method with the Navy Method**

Unlike the U.S. Navy, the U.S. Army has a great deal of experience and collective wisdom on planning complex medical operations other than war. And, while the Army has not yet written a manual on planning the medical aspects of MOOTW, it has produced the “Handbook for Soldiers in Operations Other Than War” that recognizes the medical department as an integral player in MOOTW. Chapter V contains a set of questions that originated in this handbook, but has subsequently been expanded, changed, and adapted for use by a medical planner. It provides a mental checklist a planner could apply when planning a MOOTW operation. As in every situation, adaptability and flexibility are the keys to success. The medical planner must determine which set of questions are applicable to the situation he or she is facing.

Earlier in this thesis we mentioned the Fleet Marine Force Field Manual 4-50 Health Service Support (1990), and further identified it as the primary, albeit superceded, reference for Navy operational medicine. No single chapter in FMFM 4-50 deals with MOOTW, and through this omission it tacitly denies the unique nature of MOOTW for the medical department, and therefore implies that a “one size fits all” approach (HSS Appendix) will suffice. The authors’ personal experience, along with the responses of the primary sources interviewed, suggest that this approach is flawed. We suggest that more task-oriented approach is needed.

Chapter 7 of FMFM 4-50 is devoted to medical planning and, as mentioned earlier, relies heavily on the HSS estimate and Appendix. The U.S. Army, on the other hand, has published FM 8-55, Planning For Health Service Support (1994). This manual is not devoted specifically to planning for MOOTW either, but does offer a broader approach to medical planning given that it does not adhere strictly to the combat

paradigm. Furthermore, it offers a level of detail that is unparalleled in FMFM 4-50. FM 8-55 also parallels FMFM 4-50 in terms of how to build an appendix to the OPLAN using a structured estimate and the five paragraph format.

In support of achieving that goal FMFM 8-55 offers a set of principles for planning medically complex contingencies. More importantly, it provides a great deal more detail and emphasizes topics other than those emphasized in FMFM 4-50. Neither the principles nor the details focus on MOOTW, but amalgamating the Army's medical planning principles, the Soldier's Handbook on OOTW, FMFM 4-50, the Joint Lessons Learned database, and the information garnered from primary source interviews we already are able to put together a more task-oriented document/guide to be used by Navy medical planners in the future.

Following our approach, Navy medical planners must be reasonably familiar with the contents of FMFM 4-50, regardless of its supposed obsolescence, and should have a copy in reasonable proximity at all times. Because, the authors recognize that it is not likely a Navy medical planner will have ever reviewed the Army FM 8-55, much less possess a copy, portions of Field Manual 8-55 (1994), specific to the planning process and corresponding to the Navy's FMFM 4-50, are provided in condensed form in the following pages. Appendices B and C provide the reader with sample formats from both Navy and Army HSS estimates and appendices, for comparison.

The principles outlined in FM 8-55 provide the planner with a mental outline that can be used in virtually any planning contingency. The manual articulates that a good plan:

- Provides for accomplishing the mission.
- Is based on facts and valid assumptions. All pertinent data have been considered for their accuracy, and assumptions have been reduced to a minimum.
- Provides for the utilization of existing resources. These include resources organic to the organization and those obtainable from higher headquarters.

- Provides for the necessary organization. It clearly establishes relationships and assigns responsibilities.
- Provides for personnel, materiel, and other arrangements for the full period of the contemplated operation.
- Provides for decentralized execution of the plan. It delegates authority to the maximum extent consistent with the necessary control.
- Provides for direct coordination during execution between all levels.
- Is simple. It reduces all essential elements to their simplest form and eliminates those elements not essential to successful action.
- Is flexible. It leaves room for adjustments because of operating conditions and, where necessary, stipulates alternate courses of action (COA).
- Provides for control. Adequate means exist, or have been provided, to carry out the plan according to the commander's intent.
- Is coordinated. All elements fit together, control measures are complete and understandable, and mutual support requirements are identified and provided for.

These principles provide the planner, inexperienced or not, with a mental framework from which to work. In the following section we begin to fill in the details. Regardless of the mission type or situation, a planner must understand that every situation is unique and no “boiler plate” estimate or planning method is going to provide answers for all of the needs/questions of every mission.

The principles listed previously, the outline provided below, and this thesis are intended to provide the reader with guidelines, food for thought, and a nudge along the right track. Nothing contained in this thesis—produced by the authors, or taken from established doctrine—should be misconstrued as an absolute way to plan a medically complex mission. All of this information should serve the medical planner as a tool and a place from which to begin.



#### **4. The Planning Process**

Regardless of the mission type, the operational commander will require that all plans produced by his or her staff, be presented in the “Five Paragraph” format accepted as doctrine by the U.S. Navy, Marine Corps, Army, and NATO. As mentioned earlier in this chapter, the Joint Operations Planning and Execution System (JOPES), FMFM 4-50, FM 8-55, the Joint Staff Officers Guide, and even the MCWP 4-11.1 (although tacitly), recognize the need for familiarity with this method.

The Army’s FM 8-55 provides what can only be described as a heavily detailed outline of the five paragraphs (compared to FMFM 4-50). Since readers interested in this subject can still obtain a copy of FMFM 4-50 or FM 8-55, they will not be reproduced in this work. Portions of FM 8-55 will be outlined later in this chapter to facilitate a comparison between the two manuals.

To better understand how a Health Service Support plan is formed, it is essential that the reader be familiar with the different types of plans and the military planning process itself. There may be minor differences in the processes, but the concepts themselves are generally accepted by all branches of the armed services. Essentially, military planning can be broken down into two types: deliberate and crisis. Neither FMFM 4-50 nor FM 8-55 distinguish between the two, but it is important to point out that the Joint Staff Officers Guide (JFSC 1, 2000) and the Doctrine for Planning Joint Operations (Joint Publication 5-0, 1995) do differentiate between them. This is important since MOOTW, like all military operations, are constantly evolving toward jointness, and most MOOTW are conceived out of crisis. Although FMFM 4-50 does not distinguish between deliberate or crisis planning, nor does it mention joint planning, and FM 8-55 does not mention crisis planning specifically, FM 8-55 does delineate “Joint Health Service Support Planning and Joint Crisis Action Planning” (FM 8-55, chapter 2, sections V-VII). Accepted Navy doctrine thus applies the deliberate planning method even though MOOTW are typically born out of crisis. From an operational perspective this reflects a conventional combat paradigm e.g., organic personnel, supplies, and

expected patient type. The conspicuous absence of any mention of either crisis or joint planning guidance in FMFM 4-50, and/or the lack of detail in the MCWP 4-11.1 should be an indicator of the need for serious scrutiny by Navy/Marine Corps doctrine writers.

An abbreviated version of the planning process begins with the crisis, building estimates to support the Commander's intent, choosing a course of action, and finally morphing the estimate into a plan based on the Commander's concept of the operation.

Building a medical estimate is the first major step in the planning process, and in many cases it will be difficult to determine when the estimate ends and the plan begins. It may be helpful for the planner to think of the estimate and planning processes as parallel not linear concepts. The estimate should be a timesaving and integral part of the planning process. Many people tend to think of the estimate portion as an academic exercise, but in fact the estimate phase is where the valid planning is done.

Critical to any plan, regardless of the mission or situation, is that it must always support the tactical commander's intent. Anything else is arrogant and courts disaster.

In a comparison of Health Service Support Planning methods (i.e. Navy, Army), there are a couple of key points that must be considered. First, there are seven military publications that one must review: Health Service Support (FMFM 4-50, 1990), Planning for Health Service Support (FM 8-55, 1994), the Joint Staff Officers Guide (JFSC Pub 1, 2000), the Doctrine for Planning Joint Operations (Joint Pub 5-0, 1995), the Joint Doctrine for Military Operations other than War (Joint Pub 3-07, 1995), the MCWP 4-11.1, and the Multiservice Procedures for Humanitarian Assistance Operations manual (1994).<sup>12</sup> FMFM 4-50 is the simplest and thus adheres to one of the key principles of good planning. Yet, while it may be simple, it could just as easily be labeled vague. Each of the Joint manuals complicates the planning process and almost wholly ignores the medical aspects. This is only somewhat true with the Multiservice HA manual. And, though the Army's FM 8-55 does not address MOOTW to any real depth, it does at least acknowledge its uniqueness. Additionally, it provides a level of detail for building the

---

<sup>12</sup> This manual is designated differently by each of the military services: USA FM 100-23-1, USMC FMFRP 7-16, USN NDC TACNOTE 3-07.6, USAF ACCP 50-56.

estimate not offered elsewhere. A cursory review of FMFM 4-50 and FM 8-55 reveals a great deal of similarity. It is as if one of the two was heavily used in drafting the other, though FM 8-55 supplies for more detail. Thus, the following pages are extracted directly from FM 8-55. Details that specifically go beyond FMFM 4-50 are italicized.<sup>13</sup>

## **1. Mission**

a. The senior medical commander/command surgeon is responsible--

(1) For analyzing the mission of the command from the HSS perspective.

*(2) For outlining the concept of HSS operations, assigning taskings, and providing guidance for a casualty care system in support of the commander's intent and concept of operations.*

*(3) For coordinating HSS with civil affairs, other Services, and/or alliance and coalition partners, and other government agencies.*

*(4) For coordinating HSS with host nations by providing medical liaison teams to countries with which the US has HSS agreements or with relief agencies participating in the operation in concert with civil affairs.*

*(5) For anticipating the lack of HSS infrastructure in a host nation and determining the impact upon refugee management.*

b. The HSS mission is the basis for the estimate and is stated clearly in paragraph 1 of the estimate. It always conforms to the operations in which the supported personnel are engaged. *For example, the mission might be to provide HSS to the 52d Mechanized Division in a deception operation on 10 and 11 June 92. The division attacks on 110310 June to secure high ground on Hills 123, 456, and 789. 3d Brigade makes the main attack on the west. In another example, the mission may be to save lives by providing basic medical care, medical evacuation, and preventive medicine (PVNTMED) sanitation enforcement and education.*

## **2. Situation and Considerations**

---

<sup>13</sup> Using italics this way allows the reader to compare FM 8-55 with FMFM 4-50 without having to read the pertinent sections of both manuals.

The health service situation will consist of HSS facts, assumptions, and deductions that can affect the operation. In this logical and orderly examination of all the HSS factors affecting the accomplishment of the mission, the HSS planner must be familiar with the commander's intent. The information required includes medical intelligence which is obtained through supporting intelligence channels. The planner must conduct a thorough evaluation of the enemy situation and the area of operations (AO) from the standpoint of their effects on the health of the command and HSS operations. These are enumerated as follows in paragraph 2 of the estimate:

a. Enemy Situation. From his specialized point of view, the surgeon must consider the enemy's ability to adversely affect the HSS operations of the command.

(1) The enemy's attitude toward the Geneva Conventions could alter HSS if he is likely to attack the friendly HSS system, or *if he is known to have attacked it. It could also determine the type of medical care friendly prisoners of war can expect.*

(2) The enemy's strength, disposition, probable movements, logistic situation, and combat efficiency must be considered to estimate the number of patients requiring hospitalization and evacuation.

(3) The enemy's ability to inflict conventional and unconventional (NBC and DE warfare) casualties is a concern. The type of enemy weapons employed will influence the number and type of combat casualties. *Heavy artillery bombardment, air attack, surprise weapons and tactics, and continuous operations increase battle fatigue casualties, while guerrilla or terrorist attacks cause other combat stress reactions. Supplementary hospitalization and evacuation resources may be required.*

(4) The enemy's medical capabilities, sanitation discipline, and the health of potential enemy prisoners of war (EPW) can be expected to influence the command's medical work load as well as the EPW patient work load.

b. Friendly Situation. A preliminary estimate of medical work loads can be made when the friendly forces' strength, combat efficiency, position, weapons, and plan of action are compared with those of the enemy.

(1) This comparison considers the tactical plan of the commander to determine the location of areas of casualty densities and the best placement of HSS units.

*(2) He must consider the enemy's ability to disrupt the rear operations of the command. Medical units in the rear must be incorporated into base clusters. Units must be positioned logically to ensure maximum security. These facilities are so numerous that in many cases the ideal type of security may not be available. The threat to these units must not be aggravated by positioning them near areas of high attack probability such as ammunition or nuclear storage facilities. To successfully defeat enemy deep operations, clear-cut lines of authority for security must be established. These lines of authority must be clearly identified at all echelons before any plans or operations are initiated.*

*(a) Article 24 of the GWS provides special protection for "Medical personnel exclusively engaged in the search for, or the collection, transport, or treatment of the wounded or sick, or in the prevention of disease [and] staff exclusively engaged in the administration of medical units and establishments. . . . [Emphasis added.]"*

*(b) The GWS does not itself prohibit the use of Article 24 personnel in perimeter defense of nonmedical units such as unit trains logistics areas or base clusters under overall security defense plans, but the policy of the US Army is that Article 24 personnel will not be used for this purpose. Adherence to this policy should avoid any issues regarding their status under the GWS due to a temporary change in their roles from noncombatant to combatant. Medical personnel may guard their own unit without any concurrent loss of their protected status.*

c. Characteristics of the Area of Operations. The HSS planner should obtain medical intelligence regarding the AO from the supporting intelligence element. This information must be considered in the planning process. The characteristics of the AO influence the number of patients, as well as their collection and evacuation.

(1) Terrain.

(a) Topography has the same bearing on HSS planning as it does on tactical planning. Using terrain to one's advantage may reduce combat casualties therefore decreasing the anticipated patient work load.

*(b) Natural conditions may favor large populations of arthropods (insects, arachnids, and crustaceans) which commonly are vectors of many diseases and therefore could directly increase the incidence of disease.*

*(c) Mountains, forests, and swamps can be expected to hamper HSS. Altitude exposure at high terrestrial elevations frequently results in reduced military performance and can result in acute mountain sickness. Transfer of patients from shore to ship is particularly dependent upon coastline and harbor conditions. Availability of roads, landing strips, and railroads will be important in developing evacuation alternatives. Terrain factors such as protection, shelter, and water supply are considered in consonance with evacuation alternatives and with the selection of medical treatment facility locations. Evacuation resources must be augmented when using difficult terrain.*

*(d) An increase in the hospital bed allocation should be considered if the terrain analysis suggests a significant increase in battle injury (BI), wounded in action (WIA), disease admissions, or difficulty in evacuating patients. Preventive medicine detachments should be tasked to reinforce forward deployed units if disease potential warrants.*

*(e) The duration of hazards from chemical-biological warfare agents may increase in the forest where the air is still and the foliage is thick.*

## (2) Weather and climate.

(a) Climate influences the incidence of frostbite, hypothermia, snow blindness, immersion injuries, sunburn, heat exhaustion, heatstroke, combat stress, and other medical manifestations that detract from combat unit effectiveness.

*(b) Tropical, desert, and tundra conditions strongly favor the growth of arthropod populations that highly increase the incidence of disease casualties. Preventive medicine units become increasingly important under such adverse conditions.*

(c) Humidity may affect storage life of medical supplies and equipment.

*(d) Precipitation affects available water supply, may impact on hospital site selection, and may damage unprotected supplies. Rain and snow will have dramatic effects on roads, changing evacuation routes and increasing turnaround times.*

(e) Temperature variations may require special protection of medical supplies and may increase patient load because of heat and cold injuries. *Weather also impacts on the level of degradation incurred while in mission-oriented protective posture (MOPP) and thus has a direct impact on heat casualty volume.* Additionally, requirements for medical facilities, supplies, and evacuation resources can be expected to increase. Because the rate of deterioration of health service logistics is influenced by both climate and weather, storage facilities must be estimated accordingly. Evacuation alternatives, particularly by air, will be highly influenced by weather conditions.

(3) Dislocated civilian population and enemy prisoners of war.

*(a) Wartime stress and physical damage can lead to rapid deterioration of urban and rural utilities such as electricity, water, and sewage services. Consequent increases in communicable disease could present a threat to which friendly forces are vulnerable. Enemy prisoners of war and refugee populations also tend to be sources of communicable disease. Because cities and towns tend to be located along axes of peacetime economic activity, they invariably confront CSS units moving on main supply routes (MSRs) and at crossroads of principal highways. Even if a disease outbreak is suspected, bypass of such areas is generally impractical. Refugee populations, if not properly managed by local authorities or military police, also tend to concentrate on major transportation routes.*

(b) Civil Affairs (CA) and military police have the responsibility of working with the local authorities to manage the flow of refugees.

(c) Preventive medicine teams could be tasked to assist local authorities to reactivate essential civilian sanitary services, or to establish hygienic refugee assistance facilities.

*(d) Veterinary units may be used to assist in the control of animal diseases that present a risk to the human population or to the agricultural economy. Veterinary units will also inspect subsistence fed to dislocated civilians and EPW to prevent foodborne diseases, as required. This will limit the impact these populations have on Army Medical Department (AMEDD) resources.*

*(e) If resources permit, MTF or medical treatment/holding cot allocations could be increased to accommodate known or suspected outbreaks of disease.*

*(f) Class VIII and Class X materiel (materiel to support nonmilitary programs) could similarly be accumulated in anticipation of a larger demand.*

*(g) Increased evacuation and hospitalization requirements for dislocated civilian populations will be supported by local resources, nongovernmental organizations, and relief agencies, whenever possible. Coordination with these local medical agencies should be proactive and accomplished in concert with CA units. This should minimize the strain on military medical resources.*

*(4) Flora and fauna. Certain kinds of arthropods, animal diseases, and toxic plants encountered in the area may also contribute to the noneffective rate of the command. Orientation of personnel and safeguards against arthropods, animals, and vegetation may be necessary. Preventive medicine units can develop desired information. Veterinary units can evaluate the local crops and animals for availability and suitability as fresh food sources. As a TO expands and matures, more fresh food will be needed to support US Forces.*

*(5) Disease. The effects of major diseases are delayed because of incubation periods. Knowledge of potential losses to malaria, dengue, sandfly fever, typhus, and other endemic disease is invaluable in determining appropriate preventive and control measures. These measures include requirements for basic personal protective measures, immunizations, chemoprophylaxes, immunoprophylaxes, pest management, or other appropriate measures. Should time not allow for preventive measures, disease information will be essential in estimating disease rates and for projecting strength changes in maneuver units.*

*(6) Local resources. The HSS planner requires information concerning the availability from local sources of such items as food, ice water, pharmaceuticals, and medical gases (oxygen and anesthetics).*

*(a) Although other units of the command are responsible for procuring food and water, appropriate veterinary services or PVNTMED detachments are responsible for food wholesomeness, hygiene, safety, and quality assurance and for water treatment and storage.*

*(b) Availability of pharmaceuticals or medical gases in the area affects supply stockage levels and transportation required for the operation.*

*(c) The use of local facilities such as hospitals, medical clinics, dental and veterinary schools, and their associated staffs should be considered.*



(d) The civil-military operations (CMO) staff can provide liaison with indigenous health professionals and organizations.

*(7) Nuclear, biological, and chemical and directed-energy weapons. The numbers and types of NBC/DE casualties depends on the scenario. However, these weapons produce mass casualties (MASCAL) whenever they are used. The uncertainty concerning the numbers, types, and extent of injuries from NBC or DE weapons is made even more complex since injuries from more than one type of these weapons can affect the methods of patient treatment and prognosis. Another example is that acute ionizing radiation exposure increases the morbidity and mortality of virtually all patient types. Such insidious weapons and devices also produce a large number of patients with stress-related injuries whose symptoms may be difficult to distinguish from true signs of injury. Nuclear, biological, and chemical weapons may produce large numbers of patients during a single attack so that medical units will have to face large peak patient loads. Directed energy weapons may also be used by the threat force. The effects could be severe on HSS operations.*

*(a) The CMO staff can identify nonmilitary organizations to support HSS operations under these conditions.*

*(b) The NBC and DE threat must be evaluated and included in the overall planning concept to determine how to counter it. All medical units must be prepared to execute coordinated MASCAL plans.*

*(c) Health service support units will not generally establish themselves in a contaminated environment. However, all units in the theater are at risk of attack. Furthermore, remaining or entering a contaminated area may be required to provide HSS. Commanders must ensure that units and personnel are prepared to survive, defend, and continue operations in or near a contaminated area by instituting MASCAL standards for medical treatment. Presence of critical facilities such as nuclear power plants or chemical plants could impact on medical operations. The Bhopal and Chernobyl incidents are excellent examples of how these type facilities could affect medical operations.*

*(d) Veterinary service personnel will advise all DOD theater logistics units and user units on storing subsistence to prevent NBC contamination, on monitoring and detecting NBC contamination of rations and, when necessary, on decontaminating rations to ensure food safety.*

*(e) Preventive medicine units and all HSS personnel will be alert for abnormal disease patterns in order to detect NBC effects. The sick soldier or local population is likely to be the first indication of biological warfare use; rapid identification may be critical to the survival of theater forces.*

*(f) The Area Medical Laboratory (AML) has special capabilities to support HSS units in NBC environments.*

d. Strengths to be Supported. The strengths to be supported are usually shown in a table in which the personnel strength is broken down into categories indicating the types and amounts of support to be required. These categories may include Army, Navy, Air Force, Marines, allies, EPW, indigenous civilians, detained persons, and civilian internees. Various experience rates are applied against these strengths to estimate the expected patient load. The detail in which the tabulation is prepared varies with the scope and type of the operation.

e. Health of the Command.

(1) An important consideration in making the estimate is the health of the command. The following factors affect casualty estimates and indicate command and medical measures that should be taken prior to each operation being planned:

Acclimation of troops.

Presence of disease.

Status of immunizations and drug prophylaxis.

Status of nutrition.

Adequacy of clothing and equipment.

State of fatigue, morale, unit cohesion, and training.

Physical conditioning.

Oral health fitness level.

*(2) The planner is concerned with providing HSS regardless of patient origin. He is interested in all causes for patient admission, requirements for beds, geographic dispersion of patients, and the accumulation in medical work load. Combat commanders are primarily interested in assessing combat power from which they can develop alternatives for subsequent operations. The surgeon is best served by data expressed as "rates/1000/period," which simplifies planning for HSS. The commander can better evaluate alternative operational concepts if projected losses are expressed as "percentage reduction" in combat strength of combat units. Recognizing that major disease impacts are delayed because of incubation periods, knowledge of potential losses to malaria, dengue, sandfly fever, typhus and similar diseases is invaluable for--*

- *Phasing the proposed tactical operations.*
- *Managing individual replacements.*
- *Task organizing maneuver units for the next operation.*

*(3) Therefore, if disease is expected to exert a significant impact on the force, consideration should be given to projecting changes in the strength of subordinate components not only for disease and combat losses expected during the operation of concern but also for disease losses that will exert their operational impact during following periods. The return to duty (RTD) rate of WIA and disease and nonbattle injury (DNBI) cases is also of primary interest to the commander and staff.*

f. Assumptions. An assumption is a supposition on the current or future course of events, assumed to be true in the absence of positive proof. Assumptions are sometimes necessary to enable the planner to complete the estimate of the situation and to decide on a COA to support the operation. In addition to a statement of facts, logical assumptions are included in this paragraph as a basis for development of the estimate. Subsequently, these assumptions may be deleted or modified as new information becomes available. Assumptions are usually restricted to higher levels of planning and normally apply only to factors beyond the control of friendly forces such as enemy capabilities and weather.

g. Special Factors. Factors that are not listed elsewhere or items of such importance to the particular operation that they merit special consideration are mentioned. *For example, how patients suffering from combat stress may affect the operation is a consideration.*

### 3. Health Service Support Analysis

The analysis in paragraph 3 of the estimate is a logical comparison of the estimated requirements of the command and the support means available for the operation.

a. Patient Estimates. Estimates of patients can be prepared from data compiled in paragraph 2 of the estimate. Patients are estimated as to number, distribution in time and space, areas of patient density, possible MASCAL, and lines of patient drift and evacuation. The surgeon can consult experience tables to assist him in determining requirements for the operation. From this data, hospital bed estimates can also be made.

*b. Support Requirements. Requirements are calculated from the estimate of patients and the data contained in paragraph 2 of the estimate. The planner should consider separately the requirements for the following:*

*(1) Patient evacuation, medical regulating, and patient reporting and accountability.*

*(2) Hospitalization.*

*(3) Health service logistics, to include blood management.*

*(4) Medical laboratory services.*

*(5) Dental services.*

*(6) Veterinary services.*

*(7) Preventive medicine services.*

*(8) Combat stress control (CSC) services.*

*(9) Area medical support.*

*(10) Command, control, communications, computers, and intelligence.*

*(11) Support to other Services.*

*(12) Others, as appropriate.*

Neither the resources available nor the allotment of specified units should be considered at this stage in the analysis. Only the HSS resources REQUIRED to support the commander's operation plan are determined.

c. Resources Available. Having determined the HSS requirements, the surgeon then considers the resources on hand or readily available to meet the requirements. Maximum use of available personnel and supplies promotes the overall effectiveness of the HSS of the command. To ensure all aspects of HSS are considered, review the following supporting categories:

(1) Organic HSS units and personnel. Medical units that are organic components of the command are listed and under each is a statement describing its location, strength, and readiness for action. Professional and specialty personnel capabilities must also be considered.

(2) Attached medical units and personnel. Medical units already attached and those that may be readily available, their locations, strengths, readiness, and professional and specialty personnel capabilities are considered.

(3) Supporting medical units. Consideration is given here to the evacuation and other support furnished by higher echelons as well as from the Air Force and the Navy.

(4) Civil public health capabilities and resources. Host-nation medical personnel and supplies reported by CA as available from civil public health must also be listed. Civilian medical facilities and personnel may be used in some cases to augment military facilities; in other cases, the surgeon may be requested to give them support. He should be acquainted with their potential. Cultural differences and medical care philosophies can impact on health care provided. Civil Affairs personnel assist in planning for the maximum of host-nation support. They also assist in carrying out host-nation agreements.

(5) Indigenous or retained medical personnel. Consideration is given to the use of indigenous and retained personnel and their supplies in providing medical care for their respective categories of personnel.

(6) Health service logistics. The surgeon must consider supplies and equipment on hand, immediate resupply availability, the condition of this materiel, and the organization's capability to maintain it.

*(7) Medical troop ceiling. The medical troop ceiling should be reviewed by the command surgeon to determine the possibility of securing additional medical support units. This action should be effected as early as possible to ensure the timely receipt of the required units.*

d. Courses of Action. By taking into consideration all support requirements and resources available, the planner can then determine major problem areas and difficulties. Based on this determination, several possible COA can be developed and listed which will provide the necessary HSS. *In this subparagraph, the planner lists these COA and considers policies, standing operating procedures (SOPs), and procedures that will accomplish the support mission. He limits himself to such considerations as--*

*Centralization versus decentralization of HSS. (Will authority be delegated to the maximum extent consistent with the necessary control?)*

- *Dependence on evacuation by other Service components.*
- Extent to which civilian and EPW labor will be used.
- Evacuation policies.

#### **4. Evaluation and Comparison of Courses of Action**

In paragraph 4 of the estimate, the planner evaluates and compares the various COA developed in paragraph 3. He does this by comparing the COA to determine which one CAN best BE SUPPORTED FROM THE HSS PERSPECTIVE. He lists those difficulties which will have different effects on each possible COA. This then enables him to evaluate these COA in terms of their inherent strengths and weaknesses. By next comparing the possible COA in the light of these strengths and weaknesses, he is able to identify further the basic advantages and disadvantages of each. He does not draw conclusions at this time, but defers this action until the comparison of all possible COA is completed.

#### **5. Conclusions**

a. Paragraph 5 of the estimate represents the end of the thought process of the estimate and is the basis for the development of the HSS plan. The statements represent the command surgeon's or medical commander's "decision" and serve as a guide to other staff members and/or subordinates in their planning.

b. The planner--

(1) Indicates whether the HSS mission for the operation can/cannot be accomplished.

(2) Indicates which COA can best be supported from the HSS perspective.

- (3) Lists factors which may adversely affect the health of the command.
- (4) Lists the limitations and deficiencies in the preferred COA that must be brought to the commander's attention.
- (5) Includes a COA which is less than desirable, but which best supports the commander's operational mission with the most economical use of available HSS resources.
- (6) Provides a general statement if the HSS mission cannot be accomplished.

## **5. Analysis of the Army/Navy Process**

There are at least four fundamental differences between Navy/FMF medical capability and Army medical capability. First, as was mentioned earlier in this chapter, the Navy/FMF system does not possess a dedicated aero-medical evacuation system. Aero- medical evacuation is conducted on a “lift of opportunity” basis only. Second, the Navy does not employ veterinarians for bulk food inspection. This is accomplished by Preventive Medicine Technicians. Third, the Navy does not employ Mental Health Units. The Navy does, however, employ mental health professionals, but not in a field unit organization. Fourth, the Navy does not possess an “Area Medical Laboratory.” Medical laboratories are part of the organization, but their capability is limited to clinical laboratory science, not NBC testing.

One additional area where Navy and Army techniques differ is in the use of enlisted medical personnel in a combatant role. In the FMF, a Corpsman is expected to perform duties that support the primary mission of the unit to which he is assigned. His noncombatant status is vague to say the least, and in certain FMF units is removed altogether.

Further, and putting aside the inadequacies of the current Navy medical planning doctrine (NCWP 4-11.1), FM 8-55 is a comprehensive medical planning document. Designed for the inexperienced planner, the FM 8-55 includes information that ranges

from historical operations to T/E's and T/O's for combat stress units. The Navy would do well to use the FM 8-55 as guide for writing medical planning doctrine in the future.

## **B. SUMMARY AND CONCLUSION**

The demographic make-up of the patient population will almost always be different in MOOTW deployments than in normal combat situations. So will the types of medical conditions seen, and the general nature of the medical care provided. For instance, medical personnel on humanitarian relief missions will frequently encounter infectious and parasitic diseases, while those deployed on peacekeeping operations in the Balkans have treated structural injuries and poisonings (Gauker, Covey, Emens-Hesslink, Moya, Konoske, 2000). To ensure successful medical support for these operations, JTF staffs, medical planners and logisticians need to accurately represent the function of the organization, and be prepared to plan missions that meet the needs of the recipients, the commander, and the politicians.

According to General J. H. Binford Peay III, USA, CINCCENTCOM:

Deployed medical forces must be able to handle a range of military operations in the most remote and austere regions of the world. To get more out of this finite resource and to promote greater unity of effort... effective C4 is paramount (p. 70-71, 1997).

General Peay goes on to emphasize the importance of clear lines of communication throughout the JTF staff, and points out that filtering [health service] information through other staff officers has the potential to cause conflict within the staff, especially when the information might conflict with the prerogatives of the responsible staff officer.

The current organizational paradigm, regardless of doctrinal suggestions, is stovepiped and structure-oriented. The variety and frequency of MOOTW mean that some paradigms may need to be broken.



As we have noted several times already, the assumptions implicit in Navy/FMF HSS doctrine do not extend to MOOTW. Even a cursory evaluation of the system demonstrates that, short of a specialized medical unit, the operations commander, the operations planner, and the medical planner must be aware of the implications that exist when deploying in support of MOOTW. MOOTW require that special attention be given to: medical intelligence gathering and exploitation of the population in need, multinational supporting personnel, G.O's, and N.G.O's; the T/O—especially in the physician specialist mix; the T/E and AMAL makeup; and the preventive medicine/public health needs of the population and the environment in which the operation takes place.

Given the unique demands MOOTW and especially HA make on DOD medicine, commanders and planners must take into consideration things that are taken for granted in combat planning: long lines of communication, limited lift, short warning time, lean combat and combat support forces, multiple patient type demographics, and the political nature of the mission. Current planning doctrine and systems do not make allowances for missions that differ from conventional combat, yet most everyone agrees that MOOTW are unique and will continue to be a draw on our national resources.

Although it will be discussed in more detail in Chapter V., the authors want to emphasize the need for the Navy to either produce its own doctrine specific to the medical aspects of MOOTW, or adapt and/or adopt the FM 8-55 for use by Navy medical planners.

## V. CONCLUSIONS AND RECOMMENDATIONS

### A. STRATEGIC CONCLUSIONS

#### **1. The FMFM 4-50 is outdated and in need of re-work to include consideration of the critical role that the Health Affairs element plays.**

We sturdily recommend that the currently utilized FMFM 4 –50 be updated and expanded to include HA, and that MCWP 4-11.1 be scrapped. Furthermore, while the authors fully support the concept of maintaining “platform cohesiveness” we believe a database of experienced HA planners should be maintained by BUPERS to facilitate finding and employing experienced personnel when the need arises. The Advanced Qualification Code (AQD) system currently in use would suffice. Why, after all, do we maintain an AQD for those Officers who have qualified as Surface Warfare Officers? It is because it gives BUPERS quick access to a pool of experienced Officers. HA planning, given its high visibility and political nature should be treated with equivalent seriousness.

#### **2. More consideration should be given when assigning personnel to operational platforms, e.g. aircraft carriers and amphibious assault ships.**

As we mentioned in Chapter III. the officers that will be tasked with planning the initial movement into a MOOTW theater under current assignment policy are not trained planners. Therefore, we recommend that Medical Service Corps officers assigned to operational platforms attend the POMI course of instruction, and if possible, the Armed Forces Medical Intelligence Center “short course.” Contrary to what the reader might think however, we do not recommend that MSC’s assigned to operational platforms should not be Patient Administration officers. That is to say, Patient Administration does consume the bulk of the MSC’s time during that assignment, but given that the initial movement ashore for a MOOTW mission will set the tone for the remainder of the

mission, more consideration should be given concerning the training provided to the officer who will set the tone.

**3. The author's research acknowledges that internal and external pressures tend to expand the mission of the medical element.**

In HA the demand for services is frequently open-ended and has the potential to consume large amounts of resources. Factors which contribute to larger missions include the aforementioned needs of in-place coalition partners, demands that are induced by the United States' actions in-theater, excess capacity,<sup>14</sup> outside requests by agencies such as the UN and the U.S. State Department, in addition to the ethical and professional considerations of necessarily loosely defined missions. With these factors in mind we believe a few actions are in order which might serve to bracket the medical mission suitably. First, clarify the mission from the start. This must include the medical mission, its objectives, the desired end state, and classes of patients that are deemed qualified for services. Second, the medical management of civilians must be limited to the level of care that is customary, in that particular region. The United States cannot impose its standard of care on a host nation that cannot sustain that level of care once the U.S. military departs. Third, the United States must address repatriation challenges by establishing guidelines or rules for evacuating coalition partners personnel and refugee patients to their home or third party countries, including the continental U.S.

**4. There is a scarcity of readily accessible and meaningful operational lessons learned.**

Given this fact we would like to offer some of our thoughts concerning common threads that have emerged in the course of this research.

First, senior medical planners must be willing to step away from the accepted paradigm and consider not only the medical requirements for sustaining a deploying force, but also the broader missions that the particular department may be assigned in

---

<sup>14</sup> Excess capacity is best defined as possessing more capability e.g. Dermatology, ENT, etc., than is required to effectively complete the mission.

MOOTW. For instance, in operations involving humanitarian assistance or refugee populations, the medical mission is likely to be much broader in scope than the current paradigm recognizes. However, planners continue to view the mission of the medical personnel as limited to its conventional role in supporting combat. This view, in turn, leads to differences between the requirement and the force provided, and at times has resulted in the wasteful use of medical assets. To help alleviate this, planners should recognize the special medical requirements that are related to civilian populations and the multinational forces that are involved. The political reality of MOOTW is that the United States military may be tasked with providing care for civilians whether it is part of the official medical mission or not. Furthermore, as discussed in Chapter III., the organizational design of the Commander's staff should reflect the role the medical department will play in a specific MOOTW mission. Blindly adhering to old paradigms invites waste and can create situation that potentially could embarrass the command or the U.S. government.

Secondly, any planning should explicitly consider the varied types of at-risk populations, categories of patients, and the medical conditions that we've mentioned previously. The United States medical contingent can certainly do a better job of making predictions about the populations at risk and support requirements needed in MOOTW. To facilitate this, planning must include advance assessment teams with MOOTW proficiency. Designated teams must include physicians, preventive medicine officers, community health nurses and others with particular expertise in dealing with MOOTW.

**5. Many of today's medical department officers and enlisted personnel involved with MOOTW have little experience in the political arena or with political matters in general.**

This means that an ill-defined mission has the potential to create political problems which can quickly spin beyond the medical department's ability to control. Preventing this from occurring requires education and training. For example, for Navy medical department officers, the Officer Indoctrination School, Field Medical Service

School, and Fleet Hospital Training could include an introduction to MOOTW with the focus on the political nature of MOOTW, and the hazards of excess capacity. The varied departmental Command and General Staff Colleges could provide a forum for discussions on medical support requirements, public health issues, and other identified problems medical units will face in MOOTW. This should help the medical department do a better job, as well as familiarize potential commanders with the unique nature of MOOTW and the demands MOOTW places on the medical department.

**6. The educational process for both medical and line officers concerning MOOTW needs to incorporate departmental medical units that are involved in training for MOOTW at the Joint Readiness Training Command.**

Many of the medical decisions and practices coupled with MOOTW should be hashed out prior to deployment in contrast to relying on impromptu decision making in the field. Furthermore, senior medical commanders and core staff could receive training about how to interpret operational plans, develop tactical plans, and make the type of clinical and command decisions faced by those involved with recent MOOTW around the globe.

Health care providers at all levels (physicians, nurses, and other providers) require training in the types of treatment dilemmas they may encounter in MOOTW. They must also receive training about how to respond correctly to help avoid the tendency toward assuming undesired additional missions. And they must be taught how actions undertaken at the delivery end may inadvertently lead to an expansion of the medical mission.

**7. Coalition operations pose distinctive challenges when providing and structuring medical support.**

The United States military tends to serve as the backbone of the medical support in MOOTW, regardless of whether the mission is to support United States personnel or multinational forces. With this in mind, the United States and its key allies may wish to take the lead in developing a revised description of echelons of care that are particular to

MOOTW involving a multinational force. This plan would set standards for medical and unit readiness, training, equipment and standards of care, as well as realistic evacuation policies.

Few other militaries possess the air evacuation and medical logistical capabilities that are inherent within the United States military.

The United States must rely on its own logistical pipeline for support, rather than the UN system given the intrinsic quality problems and differences in standards.

**8. When planning for future MOOTW, special attention must be given to the extensiveness of such demands especially within multinational operations.**

Senior medical representatives will need to ensure broad based flexibility to support the diversity of new missions they may be called upon to perform when undertaking a MOOTW. Given overwhelming medical needs often met on the ground and the fact that the United States military often serves as the medical support backbone in MOOTW, the United States needs to focus and carefully monitor its medical involvement in these particular missions wherever possible. To be confronted successfully, many, if not all, of the medical issues need to be addressed at the strategic, operational and tactical levels of all services involved.

## **B. TACTICAL CONCLUSIONS**

In this section, as in the previous section, we intend to begin from a broad perspective and then finish by providing some specific recommendations for the medical planner.

**1. Better planning procedures need to be adopted, facilitated, and implemented by the Navy medical department.**

It is also the authors' opinion that the unique nature of MOOTW will not allow for an absolute foolproof one-size fits-all method. While we believe the Navy can do better, we must begin by asserting that the first key to its success will be flexibility.

MOOTW, and especially HA, by their very nature, are dynamic. To assume that a rigid, boilerplate planning method will suffice for every situation is to invite disaster. Likewise, to assume that the original plan for any operation should remain in effect without constant reevaluation defies common sense.

As has been stated numerous times in this work, a key factor necessary for success is a willingness on the part of the line and medical planner to break away from the combat paradigm while still keeping in mind that hostilities can surface at anytime, even within the most benign environment. As an example, medical facilities located within refugee camp perimeters are vulnerable to attack by the very people they are there to help.

A third key factor that both line and medical planners must be aware of and prepared for is “other agency” involvement. Inter-and extra-agency cooperation may not be required for success, but it will certainly make the Commander’s job much easier and will result in providing the best and most efficient care possible to the patient population. Military planners must recognize that many humanitarian organizations as well as other U.S. government agencies will view the U.S. military with distrust and may be very reluctant to cooperate in any part of the planning or execution process. There are a number of reasons for the inherent feelings of distrust. For one, civilian humanitarian organizations may believe that their cooperation will undermine their status as neutrals, now and in future humanitarian endeavors, leaving them vulnerable to attack. Other government agencies may feel that the very presence of uniformed military personnel is at cross-purposes with their mission. The military emphasis on planning and preparation, and the need for command and control, will likely be viewed as threats to others autonomy. And lest we forget, humanitarian aid delivery is a profit-making industry. Many of the people involved make their living by providing services to the needy around the world. U.S. military intervention, is therefore, a threat to their personal or organizational livelihood. Inter-and extra-agency cooperation in humanitarian relief endeavors is itself a topic worthy of future research, and while it will be discussed later in this section, we cannot possibly give it the attention it deserves.

## **2. Medical planners must be cautious about creating excess capacity.**

Planners must be prepared for mass casualties and make provisions for a surge capability and, as mentioned earlier, the dynamic nature of MOOTW makes some excess capacity unavoidable. The line commander and the planners must understand that excess capacity tends to stimulate demand, offering an additional avenue for mission expansion.

## **3. The Navy medical planning community should incorporate and use the “Intelligence Factors for Medical Planners” outlined below and much of the detail present in the Army’s planning guidance FM 8-55.**

We have devised the following list of questions to stimulate the thought processes of the medical planner, and to assist in the preparation of the medical estimate and eventually the Health Service Annex. We believe they should be considered for inclusion in any attempt to write new HA doctrine. This list was developed, in part, through consultation with senior medical planners with real-world experience (to include CDR Efrin Saenz, MSC, and LCDR Gina Trotter, MSC). The authors’ experience likewise played a significant role, as did the comprehensive literature review that included the Soldiers Handbook for OOTW.

Not every question in the “Intelligence Factors for Medical Planners” will apply to every situation, and some of the questions will only apply if the target population is on the move. Some will only apply to target populations that have remained in place following some sort of natural or man-made disaster. The medical planner should always ask whether the question applies to the situation, or could it be *construed* to apply.

### **a) Intelligence Factors for Medical Planners**

- What is the nature of the crisis/disaster? (This will help determine the mission)
  - Natural
    - -Earthquake/Avalanche/Mud Slide:



(Note: These tend to be high trauma-surgical-short duration evolving into infrastructure replacement and acute care)

- -Hurricane/Typhoon/Cyclone/Flooding:

(Note: These tend to be low trauma with little need for surgical intervention, acute care, extreme public health requirements)

- Man-made

- *IS FIGHTING LIKELY TO BREAK OUT AGAIN?*

- What is the security situation in the focus area?

- What element(s) have the potential to cause problems?

- Guerrillas
- Terrorists
- Government Forces
- Paramilitary Groups

- What types and quantities of weapons are in the focus area?

- Are there residual effects/complications?

- Radiation
- Biohazards
- Mines
- What are the locations of these dangers?

- Are there large numbers of homeless, or displaced people?
- Are they on the move or are they staying near their home area?
- Why did they come here?
  - Safety
  - Water
  - Weather
  - Forced
- Who makes up the majority of your patient population?
  - Military Personnel?

- Organic
    - Other Unit
    - Other Service
    - Other Country
  - Civilians?
  - Where are the refugees originally from?
 

(Note: Homeless or displaced people who will be housed in large groups are refugees, regardless of whether they are being called migrants, asylum seekers, etc.)

    - Multiple Countries
    - One Country
    - A particular region within a country
  - What is the estimated size of the known refugee population?
    - Is it expected to grow?
    - What circumstances might initiate a surge or gradual expansion?
  - What is the size of the area and population outside the focus area that may need help, i.e., is there a rural population?
  - What is the relationship of the focus area with the outlying communities?
    - Is there an urban and rural divide between the people?
  - Are they related via:
    - Ethnicity
    - Culture
    - Language
    - Religion
  - Do they support each other?
  - Are they hostile towards each other?
  - Is any portion of the population overtly discriminated against?
- (Note: You may have to seek this population out, they may not come forward for help. They may employ a different belief system that could impact the delivery of care. They may require segregation and therefore will require splitting resources.)

- What is the food and water status of the focus area?
  - What is the quality of the water source?
  - Where do the locals get their food?
- What other means of subsistence are available?
- Are the refugees/locals farmers or herders?
- What is the status of their crops/herds?
- Are the refugees transporting their crops or animals with them?
- What food items are available in the local market?
  - What are the costs of these items?
  - Are relief supplies being sold in the market?
  - If so, what items, what is their source, and what is the price?
- What is the medical status of the focus area?
  - What services are available in the focus area?
  - What is the location of the nearest medical facility?
- Is there evidence of illness and/or starvation in either the refugee or local population?

(Note: Even a small number of refugees converging on a region already at risk of famine will exacerbate the situation, and will likely cause hostility among the two peoples, even if joined by ethnicity, religion, culture, etc.)

- What portion of the population is affected?
- What was the death rate before the disaster?
- What diseases have been previously reported in the focus area?
- What diseases were reported in the original location of the refugee population?
- What civilian organizations exist in the focus area?
  - Who are their leaders?
- What civil/military organizations exist in the focus area?
  - Who are their leaders?

- What organization/leadership element does the general population seem to support or trust the most?
  - Civil Society
    - Religious Leaders
    - Tribal/Clan Elders
  - The Government
  - The Military
  - Which appears to have the most control in the focus area?
 

(Note: The appearance of control does not necessarily indicate authority)
- What other relief agencies (UN, Red Cross, Red Crescent, etc.) are operating in the focus area?
  - Who are their representatives?
  - What services do they provide?
  - What portion of the population do they service?
  - Do they have an outreach program for the surrounding countryside?
  - Will they be friendly or hostile toward your assistance?
- What commercial or business activities are present in the focus area?
  - What services or products do they produce?
- Are there population groups within the focus area in need of greater assistance than others?
  - What are their numbers?
  - Where did they come from?
  - How long have they been there?
  - What are their specific needs?
  - What is the size of any transient population in the village?
    - How will the command deal with appearance of inequity?
    - Where did they come from and how long have they been there?
- Determine the number of families in the focus area.

- What are their names (family)?
  - How many in each family?
- What skilled labor or services are available in the focus area?
- Are there trained medical professionals within the patient population?
  - How will you employ them?
- Does the focus population have any folk beliefs that might impact the delivery of medical care?
  - Are there:
    - Healers
    - Witches
    - Shamans
- Are there any religious beliefs that might impact the delivery of medical care?
- Will physical exams be necessary for each villager/refugee to gain entry into the refugee camp?
- Is there the likelihood that any of the refugees will be immigrating to the U.S. for asylum or other reasons? If so, will they need Immigration and Naturalization Service (INS) physicals? If so, will Chest X-rays and Clinical Laboratory work be required?
  - Is it common for this population to have received Bacilli Calmette-Guerin (BCG), or any other chemo prophylaxis that might alter their reaction to laboratory tests? Examples: BCG will make PPD use virtually useless and, anti-malarials eliminate the blood donor population for months, following the treatment.
- What is the prevalence of HIV, TB, etc. in the population?
- Have the refugees crossed rivers, swamps, mountains, etc. to get to where they are?
  - How might this affect their health, e.g. cholera, malaria, cold injuries, etc.?
  - What other impact might a long trek have had on the refugee population?

Additional considerations the medical planner will want to keep in mind:

Non-battle Disease and Injury (NBDI). Acute crises are usually over in a couple of days. The difficulties really begin with long-term intervention.

-NBDI always kills more people than combat

-Preventive medicine and public health will be paramount

Mental Health, Dentistry, and Optical Fabrication. These services are important for the patient population, especially children, and your own troops. (Large groups of visually impaired people add a new dimension to the overall mission, both in an operational and medical sense. Their degree of isolation is greater and more acute than that of the already isolated and scared population. People who cannot see well-will hurt themselves more often).

Infrastructure requirements. Will the local infrastructure support the organic energy and sanitation needs?

Laboratory service. A clinical laboratory is important, but a preventive medicine lab is paramount.

Blood Management. Whole blood has an extremely limited shelf life.

Veterinary Medicine. Many people rely on livestock for their literally survival. But also, livestock are socially important in ways that are not immediately apparent to us. Animal care will be important both for self esteem issues and future repatriation. Further, animals harbor disease, and a healthy animal population will reduce NBDI.

Transportation. Transportation of personnel and patients within the area, and a plan for hasty withdraw out of the area must be dealt with before the need arises.

Biohazardous and Hazardous Material Production and Disposal. Commanders are legally and morally responsible for the proper disposal of any Bio-Hazardous Material produced by their command.

In every case the planner should consider how the answers to each of the above questions would impact his or her own troops, multinational forces, and the given patient population. At the same time, the planner should be concerned about the impact he or she chooses to ignore any of the questions raised. For instance, many readers may scoff at the notion that it is important to know whether the refugee or local population is likely to turn to healers and shamans. However, if healers or shamans exist within the patient population, and the command does not work with them, they will not only continue to practice their “art” without the command’s oversight, but they might well undermine what the command needs to do to keep the population healthy and sanitary. The same logic applies to trained medical professionals as well; they should be found and utilized, not ignored. Taking into consideration local cultural practices can only enhance the relationship between the patient population and the command.

Finally, as we wrote in Chapter II, there are very few “lessons learned” in the JULLS database that deal specifically with the medical aspects of MOOTW. However, we did find some that underlined what has already been written in this work. Thus, a list of JULLS titles and numbers is provided in Appendix D. Written permission to use the JULLS data in this thesis is located in Appendix D as well.

### **C. SUMMARY**

Unique challenges are presented to United States military personnel, specifically those tasked with providing medical/logistical support when considering Military Operations Other Than War. Participants in MOOTW missions can and may be tasked with providing medical support for United States forces, multinational forces and civilian populations, thus imposing a range of demands on United States medical personnel, equipment and supplies, patient evacuation, and supplementary health care resources. As highlighted throughout our research, MOOTW often have a tendency to be open-ended and unpredictable in their demands, and military forces frequently face numerous pressures to expand operations while excess medical capacity may act as a catalyst for this expansion.

The demand for medical services in MOOTW differs from those in combat operations. The patient population is broader, and patients have additional and more varied needs. Those requiring treatment may include United States military personnel as well as coalition forces, civilian contractors, UN or NATO staff personnel, reservists, and foreign nationals. Such subgroups differ from active-duty U.S. forces in their current health status, age composition, number of females, and range of acute and chronic medical conditions requiring treatment in the theater of operations.

Many countries rely heavily on reservists and civilian contract personnel who tend to be older and therefore present further chronic medical problems than military personnel from countries that rely primarily on active duty personnel. Coalition troops tend to display wide degrees of variability in physical readiness, and may lack pre-deployment medical screening or preventive medicine support.

United States military personnel can be tasked with providing a wide range of services and must be prepared to treat infectious diseases that may include HIV and tuberculosis in addition to chronic medical conditions not common amongst United States military personnel. The presence of a significant active duty female contingent, as well as the females in the refugee population, will increase the need for readily accessible OB/GYN care, while requests to support the treatment of refugee children may necessitate the services of an on-site pediatrician.

United States military medical units frequently find that their patient population more closely resembles that of a civilian treatment facility as opposed to that of a military treatment facility in a theater of operations. The demand for services also varies greatly by type as the propensity is toward outpatient primary care, dental care, preventive medicine, veterinary services, and stress management. By contrast, the demand for trauma or surgical intervention tends to be much lower.

As the United States contends with the strategic uncertainty in the post-Cold war era, we believe that senior planners must consider the role of our military in MOOTW, whether this is peacekeeping, peace enforcement, or humanitarian assistance. Within these operations, medical issues tend to occupy a more prominent role than in combat



scenarios, and the medical support requirements tend to be broader, particularly if a multinational force is involved. For this reason, MOOTW place greater demands on medical department resources.

It must also be kept in mind that coalition partners' organic medical assets may be insufficient for the mission. Active duty personnel in a multinational force will differ in level and type of equipment, supplies, and training of their own medical personnel and units, as well as in the quality of care these assets can provide. Consequently, the United States may offset deficiencies by supplementing assets and insisting on the level of care provided in the U.S. For instance, coalition allies may be in need of prolonged hospital care that transcends available health service support, yet United States healthcare leadership may find it difficult to repatriate coalition patients if quality care is not readily available.

Public health concerns and prevention issues present themselves center stage throughout many MOOTW operations. Medical elements find themselves providing support in the areas of consumable supplies and equipment, services, education, and training in an effort to augment local efforts. Indeed, without the normal "echelons of care" in place, moving patients and getting resupplied can be extremely problematic.

MOOTW require a wide range of services. From our research we find that, typically, patient demand for emergency services tends to be reduced over time, but that "sick care" will increase until it reaches a plateau that will stabilize and resemble the trends in community medicine anywhere in the world. As a result, the eventual size of the hospital required is often small. Consequently, the military hospital may become easily inundated in a mass-casualty type scenario and medical evacuation will become a top priority. We believe that the key to alleviating this situation is to maintain a staffing level that slightly exceeds the known mission requirement. This does not mean "M+1"<sup>15</sup> because in a MOOTW, M+1 will almost certainly create excess capacity. We only suggest that planners staff their organization with a surge capability in mind.

---

<sup>15</sup> M+1 is the personnel term used to define a deploying organizations staffing level as fully staffed to support combat operations, in other words, a complete table of organization (T/O).

The authors believe that any medical support operation in MOOTW must take into account the potential existence of refugee populations, and must think about this in humanitarian terms. The degree to which the host nation's medical infrastructure has been compromised must be considered, as should be the question of whether the United States is acting unilaterally or in concert with a multinational force. Furthermore, is the level of support the United States has been tasked to supply to multinational forces sufficient, and what are the inherent differences in medical readiness among coalition troops? Finally, what is the degree of unpredictability given the coalition partners' medical assets?

Given such features, MOOTW, and HA especially, can present a broad range of resource demands with rapidly changing mission requirements. We believe this, in turn, requires that medical commanders/planners be granted maximum flexibility to tailor support based on the mission. Operation commanders/planners must be made aware of the unique demands MOOTW places on their organic medical assets, and must be educated that prepackaged organizational units, designed using a combat support paradigm, will likely create an inefficient medical support element that is either insufficient for the task or so robust as to create excess, waste, and the potential to foster mission expansion. Either of these can cause grave political consequences for the entire military and civilian chain of command.

**THIS PAGE INTENTIONALLY LEFT BLANK**

**APPENDIX A. LIST OF MOOTW FROM 1990 THROUGH 2001**

**(SORTED BY TYPE OF OPERATION)**

**PEACEKEEPING**

Sharp Guard, et al.	Bosnia	1992-Present
Restore/Continue Hope	Somalia	1992-1993
Assured Lift	Liberia	1997
Support/Uphold/Maintain/ Restore Democracy	Haiti	1993-Present

**REFUGEES**

Provide Comfort/ Promise	Iraq/Turkey	1991-Present
Safe Harbor/ JTF GTMO/Able Manner/ Able Vigil/Sea Signal/ Safe Passage	Cuba/Haiti/ Caribbean	1991-1997
Safe Haven	Panama	1994-1995 <sup>16</sup>
Guardian Assistance	Rwanda	1996

**NON COMBATANT EVACUATIONS (NEO's)**

Sharp Edge	Liberia	1990
Eastern Exit	Somalia	1991
Silver Compass	Liberia	1992
Support Hope	Rwanda	1994
United Shield	Somalia	1995
Assured Response	Liberia	1996
Quick Response	Cen Afr Rep	1996
Noble Obelisk	Sierra Leone	1997
Silver Wake	Albania	1997

---

<sup>16</sup> Safe Haven was adjunct to Operation Sea Signal.

## HUMANITARIAN ASSISTANCE

(Categorized by Disaster Type)

### Earthquake

Philippines		1990
Guam		1993

### Volcano

Fiery Vigil	Philippines	1991
Hot Rock	Italy	1992

### Storm

Hurricane Hugo	Antigua	1990
Typhoon Mike	Philippines	1990
Operation Sea Angel (Typhoon Marian)	Bangladesh	1991
JTF Andrew (Hurricane Andrew)	Florida/Louisiana	1992
JTF Hawaii (Hurricane Iniki)	Hawaii	1992
JTF Marinas	Guam	1992
Typhoon Paka	Guam	1997

## APPENDIX B: SAMPLE MEDICAL ESTIMATE AND PLAN FORMATS—NAVY

Copy no. \_\_\_ of \_\_\_ copies  
Parent headquarters  
PLACE OF ISSUE  
Date/time group

APPENDIX \_\_\_ (Medical Estimate) to Combat Service Support Estimate

Ref: (a) Maps:  
(b) etc.

### 1. MISSION

- a. Basic Mission. (Of command as a whole)
- b. Previous Decisions. (If any, such as priorities of medical support if applicable)
- c. Purposes of This Estimate. The purposes of this estimate are to:
  - (1) Assess medical capabilities and limitations.
  - (2) Determine if medical capabilities are sufficient to support proposed courses of action (C/A).
  - (3) Determine which C/A is most desirable from a medical standpoint.
  - (4) Determine what measures must be taken by the commander and his staff to overcome limiting factor.

### 2. SITUATION AND CONSIDERATIONS (Factors affecting health service support)

#### a. Enemy Situation

- (1) Strength and disposition of their forces.
- (2) Combat efficiency and capability.

- (3) Capability to inflict casualties.
- (4) Their state of supplies.
- (5) State of health.
- (6) Weapons they possess.
- (7) Capability to impede or prevent evacuation of casualties.

b. Friendly Forces

- (1) Strength and disposition.
- (2) Combat efficiency.
- (3) Courses of action. (A statement of the tactical C/As)
- (4) State of supply.
- (5) Weapons to be used.

c. Characteristics of the Area of Operations. (Those that are likely to affect the medical situation)

- (1) Terrain.
- (2) Climate and weather.
- (3) Civilian population.
- (4) Flora and fauna.
- (5) Local resources.

d. Strengths to be Supported.

- (1) Military personnel.
- (2) Prisoners of War.
- (3) Civilians.

(4) Recovered military personnel.

(5) Others (including partisans).

e. Physical Condition of the Command

(1) Origin of troops,

(2) Presence of disease.

(3) Status of immunizations.

(4) Status of nutrition.

(5) Clothing and equipment.

(6) Fatigue.

(7) Others, as indicated.

f. Medical Support Situation. (A description of the current medical situation, including any planned or known changes during the period covered by the estimate. Such description should normally include the areas cited below.)

(1) Medical Organizations. (Each medical organization is described as indicated below.)

(a) Location. (Reference may be made to an overlay.)

(b) Missions/Tasks. (Major missions/tasks of medical units)

(c) Task Organizations and Command Relationship. (As known or envisioned at this time)



(d) General Capabilities and Status. (Capabilities and status of medical units with respect to performance of the required medical functions as follows:

- Casualty collection
- Emergency treatment
- Hospitalization
- Specialized surgery
- Evacuation
- Preventive medicine).

(2) Task Organizations. (Same as shown for [1].)

g. Assumptions. (Those necessary for completing the estimate)

h. Special Factors. (Items of special importance in the particular operation under consideration)

i. Courses of Action. (Proposed courses of action are stated in full.) (NOTE: A statement of the tactical courses of action under considerations is presented here. In the medical estimate, those various medical courses of action which are within the limit of the tactical plan are also considered under this heading.)

### 3. MEDICAL ANALYSIS

(Under each of the following subheadings each course of action under consideration is analyzed in terms of requirements, availability, and limitations)

a. Course of Action #1

(1) Casualty Estimates. (Obtained from the G-I/S-1 for all major units of the command)

(2) Medical Requirements

- (a) Casualty collection/evacuation.
- (b) Emergency treatment.
- (c) Hospitalization.
- (d) Specialized surgery.
- (e) Preventive medicine.
- (f) Medical supply/equipment.
- (g) Civil affairs.

(3) Medical Means Required/Available

- (a) Organic medical units.
- (b) Attached medical units.
- (c) Supporting medical units.
- (d) Host nation support.
- (e) POW medical personnel.
- (f) Status of medical supplies.

b. Courses of Action #2. (Same as shown for #1) 4.

4. EVALUATION

(Based on the foregoing analysis, the advantages of each C/A under consideration are summarized and compared from a logical viewpoint)

5. CONCLUSION

- a. Preferred Course of Action. (A statement as to which C/A, if any, can best be supported from a medical viewpoint)
- b. Major Disadvantages of Other Courses of Action. (In sequence of desirability make a statement of significant disadvantages that render the other course(s) of action less desirable)
- c. Medical Problems and Limitations. (A statement of significant problems to be solved and limitations that must be taken into account)
- d. Decision or Action. (A statement of measures/actions required to solve medical problems that must be brought to the attention of the commander)

Signature Title  
Rank & Service

**Sample Health Services Appendix to Logistics/Combat Service Support Annex—  
Navy**

Copy no. \_\_ of \_\_ copies  
Parent Headquarters  
PLACE OF ISSUE  
Date/time group

**APPENDIX X (Health Services) to ANNEX X (Logistics/Combat Service Support) to  
Operation Order**

- Ref:
- (a) Maps
  - (b) DOD INST 6480.4, DOD Blood Program
  - (c) CINCFLTINST 6530.2F, CINCFLT Blood Program
  - (d) MCO P3040,4, Marine Corps Casualty Procedure Manual
  - (e) FMF.M 4-50, Health Service Support
  - (f) COMNAVMEDCOMINST 6230.1, Immunization Requirements and Procedures
  - (g) COMNAVMEDCOMINST 6440.1, Mobile Medical Augmentation Readiness System
  - (h) NAVMED PSOIO, Manual of Preventive Medicine
  - (i) NAVMED P5016, Handling of Deceased Personnel in Theatres of Operation
  - (j) FSSG 0 6440.1, Medical Dental SOP
  - (k) DivO 6440.4, Sanitation SOP
  - (l) Medical Regulating SOP

Planning Time Zone:

1. SITUATION

a. Enemy Forces. See Annex B (Intelligence)

b. Friendly Forces

(1) See Annex A (Task Organization), Annex D (Logistics/Combat Service Support) and/or Annex E (Personnel)

(2) Organic medical platoons and medical sections of regiments and/or separate battalion.

c. Attachments and Detachments (Effective DTG)

(1) Collecting and Clearing Company \_\_, Medical Battalion, \_\_ FSSG. (Effective DTG)

(Example: Collecting and Clearing Company A, 2d Medical Battalion, 2d FSSG.)

(2) Collecting and Clearing Company \_\_, Medical Battalion, \_\_ FSSG. (Effective DTG)

(3) Surgical Section# \_\_, Surgical Support Company \_\_, Medical Battalion, \_\_ FSSG. (Effective DTG)

(4) Triage and Evacuation Section# \_\_, Surgical Support Company \_\_, \_\_ Medical Battalion, \_\_ FSSG. (Effective DTG)

(5) Dental Detachment# \_\_, \_\_ Dental Company, \_\_ Dental Battalion, \_\_ FSSG. (Effective DTG)

(6) Medical Regulating Team# \_\_, Surgical Support Company \_\_, \_\_ Medical Battalion, \_\_ FSSG. (Effective DTG)

## 2. MISSION

a. General. See Operations Order \_\_\_\_.

b. Medical. All medical platoons, and attached medical/dental elements will land on order in direct support of attached units.

## 3. EXECUTION

a. Tasks

(1) Brigade Service Support Group \_\_, \_\_ MEB

(a) Attached: Collecting and Clearing Company \_\_, \_\_ Medical Battalion, \_\_ FSSG.

1 Land on order and establish a resuscitative treatment facility in the area to be designated.

2 Coordinating Instructions

a Be prepared to augment medical facilities of ship in which embarked.

b Be prepared to dispatch on order Surgical Section# \_\_, with essential supplies and equipment to affected area in event of casualty overload.

(2) Collecting and Clearing Company \_\_, \_\_ Medical Battalion, \_\_ FSSG.

(a) Attached: Surgical Section# \_\_, Surgical Support Company \_\_, \_\_ Medical Battalion, \_\_ FSSG. (Effective DTG)

1 Land on order and provide surgical support to Collecting and Clearing \_\_, \_\_ Medical Battalion, \_\_ FSSG.

2 On order return to Collecting and Clearing Company \_\_, \_\_ Medical Battalion, \_\_ FSSG.

(b) Attached: Medical Regulation Team# \_\_, Surgical Support Company \_\_, \_\_ Medical Battalion, \_\_ FSSG. (Effective DTG)

(c) Attached: Dental Detachment# \_\_, \_\_ Dental Battalion, \_\_ FSSG. (Effective DTG)

b. Ship Assignment

(1) USS \_\_\_\_\_ (LXXX-XXX) (Ship type-Hull #)

(a) Attached: Collecting and Clearing Company \_\_, \_\_ Medical Battalion, \_\_ FSSG. (Effective DTG)

1 Augment medical facilities of ship in which embarked.

2 On or about D+5, be prepared to land on order and establish or reinforce a limited surgical facility.

(2) Shore Party Group \_\_, Brigade Service Support Group \_\_, \_\_ MEB.

(a) Attached: Surgical Section# \_\_, Collecting and Clearing Company \_\_, \_\_ Medical Battalion, \_\_ FSSG. (Effective DTG)

1 Land on order and establish an evacuation station(s), (beach or helicopter) in an area to be designated.

2 On order return to parent collecting and clearing company.

4. ADMINISTRATION AND LOGISTICS

a. See Annex D (Logistics/Combat Service Support)

b. Medical Supply (See Tab B)

(1) Ground Units

(a) Medical Prescribed Load

1 Company corpsman will carry unit 1's.

2 BAS's will carry\_\_ equipment AMAL (635) and \_\_supply AMAL (636).

3 ES's will carry\_\_ equipment AMAL (631) and supply ANLAL (632).

4 Collecting and Clearing companies will carry the following AMAL's.

AMAL Title	Equipment AMAL#	AMT	Consumables AMAL#	AMT
Operating Room	639	XXX	640	XXX
Blood Bank	621	XXX	624	XXX
Shock Surgical Team/ Triage	631	XXX	632	XXX
Ward	633	XXX	634	XXX
X-Ray	627	XXX	649	XXX
Laboratory	618	XXX	619	XXX
Pharmacy	629	XXX	630	XXX

**NOTE:** Number of supply AMALs will be the minimum amount required to support the collecting and clearing company's mission and is determined by the number of casualties anticipated within a predetermined time period (see MCO 6700.2\_).

(b) The following emergency medical supplies will be available in floating dumps -

(c) Medical Logistics Company (Detachment) will carry remainder of supplies, and ensure that supplies are maintained at prescribed levels.

(d) Emergency resupply by airdrop (See Annex N [Air Operations]).

(2) Helicopter Forces. **NOTE:** Follow the same sequence as indicated for ground Units, keep in mind their unique mission.

(3) Captured medical supplies will be salvaged for care of POWs.

(4) Whole Blood

(a) Ashore

1 Collecting and Clearing Company\_\_, \_\_Medical Battalion,\_\_FSSG.

2 Collecting and Clearing Company\_\_, \_\_Medical Battalion,\_\_FSSG.

3 Surgical Section#\_\_, Surgical Support Company\_\_, \_\_Medical Battalion, \_\_FSSG.

(b) Afloat

1 USS \_\_\_\_\_ (LXX-\_\_)

2 USS \_\_\_\_\_ (LXX-\_\_)

(c) **NOTE:** See CINC\_\_FLTINST 6530.2 series for blood distribution in an area of operations.

c. Medical Administration. Casualty Reports (See Annex E [Personnel])

d. Casualty Overload

(1) Collecting and Clearing Company\_\_, or Surgical Support Company\_\_, \_\_Medical Battalion,\_\_FSSG will dispatch on order Surgical Section#\_\_ to affected area in event of casualty overload.

(2) In no case will evacuation of casualties in a situation of serious casualty overload be delayed for lack of complete medical records or other administrative requirements.

e. Hospitalization

(1) Ashore

(a) Collecting and Clearing Company\_\_, \_\_Medical Battalion,\_\_FSSG.

(b) Collecting and Clearing Company-, -Medical Battalion, -FSSG.

(2) Afloat

(a) Primary casualty receiving and treatment ship(s).

1 USS \_\_\_\_\_(LXX-\_\_\_)

(b) Secondary casualty receiving and treatment ship(s).

1 USS \_\_\_\_\_(LXX-\_\_\_)

(3) Civilian

(a) Sick and wounded civilians will be treated and hospitalized in accordance with Annex G (Civil Affairs).

(b) All civilian casualties will receive essential prophylactic immunizations.

(4) Prisoners of War

(a) Prisoners of war will be treated and hospitalized in accordance with the Geneva Conventions and Annex E (Personnel).

(b) Maximum use will be made of detained medical personnel, captured supplies, and equipment in the treatment of POWs.

(c) All POWs will receive prophylactic immunizations.

f. Evacuation Policy

(1) Before establishing force medical facilities ashore, immediate evacuation of all casualties requiring hospitalization is made to ships.

(2) After establishing of medical facilities ashore there will be a XX day evacuation policy.

(3) All POWs and civilian casualties will be treated ashore and not evacuated seaward unless directed by CLF or CATF.

g. Preventive Medicine and Sanitation. (See Tab A.)



5. COMMAND AND SIGNAL

- a. Command Relationship. (See Annex J [Command Relationship].)
- b. Signal. (See Annex K [Communications-Electronics].)
- c. Location of Landing Force Surgeon
  - (1) Afloat (Flag Ship)-USS \_\_\_\_\_ (LXX- \_\_\_\_).
  - (2) Ashore-to be announced.

ACKNOWLEDGE RECEIPT:

Signature  
Name  
Rank, Service  
Title

- TABS: A. Preventive Medicine and Sanitation  
B. Medical Supply  
C. Medical Regulating Procedures  
D. Distribution see Annex Z (Distribution)

## APPENDIX C: SAMPLE MEDICAL ESTIMATE AND PLAN FORMATS— ARMY

*Headquarters*

*Location*

*Date, time, and zone*

### HEALTH SERVICE SUPPORT ESTIMATE OF THE SITUATION

References: *Maps, overlays, charts, or other documents required to understand the plan.*

*Reference*

*to a map will include the map series number and country or geographic area, if required; sheet number and name, if required; edition; and scale.*

1. MISSION (*Statement of the overall HSS mission.*)
2. SITUATION AND CONSIDERATIONS
  - a. Enemy situation.
    - (1) Strength and disposition.
    - (2) Combat efficiency.
    - (3) Capabilities.
    - (4) Logistic situation.
    - (5) State of health.
    - (6) Weapons.
  - b. Friendly situation.
    - (1) Strength and disposition.
    - (2) Combat efficiency.
    - (3) Present and projected operations.
    - (4) Logistic situation.
    - (5) Rear area protection plan.
    - (6) Weapons.
  - c. Characteristics of the area of operations.
    - (1) Terrain.
    - (2) Weather and climate.
    - (3) Dislocated civilian population and EPW.
    - (4) Flora and fauna.
    - (5) Disease.
    - (6) Local resources.
    - (7) Nuclear, biological, and chemical and DE weapons.
  - d. Strengths to be supported.
    - (1) United States uniformed services.

- (a) Army.
  - (b) Navy.
  - (c) Air Force.
  - (d) Marines.
  - (e) Coast Guard.
  - (2) Department of Defense Civilians.
  - (3) Allied forces.
  - (4) Coalition forces.
  - (5) Enemy prisoners of war.
  - (6) United States national contract personnel.
  - (7) Indigenous civilians and third country civilians. (*Refer to discussion of Articles 15 and 16 of the Geneva Convention for the Amelioration of the Condition of the Wounded and The Sick in Armed Forces in the Field in FM 8-10.*)
  - (8) Detainees.
  - (9) Internees.
  - (10) Others.
- e. Health of the command.
- (1) Acclimation of troops.
  - (2) Presence of disease.
  - (3) Status of immunizations and/or chemoprophylaxes.
  - (4) Status of nutrition.
  - (5) Clothing and equipment.
  - (6) Fatigue.
  - (7) Morale.
  - (8) Status of training.
  - (9) Other, as appropriate.
- f. Assumptions. (*Assumptions may be required as a basis for initiating, planning, or preparing the estimate. Assumptions are modified as factual data when specific planning guidance becomes available.*)
- g. Special factors. (*Mention items of special importance in the particular operation to be supported such as the unique conditions to be encountered in NBC or DE warfare, or the impact that patients suffering from combat stress will have on the HSS system.*)

### 3. HEALTH SERVICE SUPPORT ANALYSIS

- a. Patient estimates, (Indicate rates and numbers by type unit /division )
  - (1) Number of patients anticipated.
  - (2) Distribution within the AO (space).
  - (3) Distribution in time during

- (4) Areas of patient density.
- (5) Possible mass casualties.  
the operation (evacuation time).
- (6) Lines of patient drift and evacuation.

b. Support requirements. *Consider separately the estimated support requirements for—*

- (1) Patient evacuation and medical regulation
- (2) Hospitalization
- (3) Health service logistics, to include blood management
- (4) Medical laboratory services
- (5) Dental services
- (6) Veterinary services
- (7) Preventive medicine services
- (8) Combat stress control services
- (9) Area medical support
- (10) Command, control, communications, computers, and intelligence.
- (11) Others, as appropriate.

c. Resources available. *Consider Air Force/Naval support in addition to—*

- (1) Organic medical units and personnel.
- (2) Attached medical units and personnel.
- (3) Supporting medical units.
- (4) Civil public health capabilities and resources. *(Civil Affairs personnel are responsible for obtaining host-nation support.)*
- (5) Enemy prisoner of war medical personnel.
- (6) Health service logistics.
- (7) Medical troop ceiling.

d. Courses of action. *(As a result of the above considerations and analysis, determine and list all logical COA which will support the commander's OPLAN and accomplish the HSS mission. Consider all SOPs, policies, and procedures in effect. Courses of action are expressed in terms of what, when, where, how, and why.)*

#### 4. EVALUATION AND COMPARISON OF COURSES OF ACTION

a. *Compare the probable outcome of each COA to determine which one offers the best chance of success. This may be done in two steps:*

*(1) Determine and state those anticipated difficulties or difficulty patterns which will have different effect on the COA listed.*

*(2) Evaluate each COA against each significant difficulty or difficulty pattern to determine strengths and weaknesses inherent in each.*

*b. Compare all COA listed in terms of significant advantages and disadvantages, or in terms of the major considerations that emerged during the above evaluation.*

## 5. CONCLUSIONS

*a. Indicate whether the mission set forth in paragraph 1 can (cannot) be supported.*

*b. Indicate which COA can best be supported from the HSS standpoint.*

*c. List the limitations and deficiencies in the preferred COA that must be brought to the commander's attention.*

*d. List factors adversely affecting the health of the command.*

*/s/*

*Surgeon (Command)*

*Annexes (as required)*

*Distribution:*

## Sample Health Services Plan-Army

Copy no. \_\_ of \_\_ copies  
Parent Headquarters  
PLACE OF ISSUE  
Date/time group

### HEALTH SERVICES SUPPORT PLAN

Reference: Maps, overlays, charts, or other documents required to understand the plan. Reference to a map will include the map series number and country or geographic area, if required; sheet number and name, if required; edition; and scale.

Time Zone Used Throughout the Plan:

Task Organization: Annex A(Task Organization) (Task Organization may appear here, in paragraph 3, or in an Annex)

#### 1. SITUATION (Provide information essential to understanding of plan)

- a. Enemy Forces. (Emphasis on capabilities bearing on plan)
- b. Friendly Forces. (Emphasis on HSS functions and responsibilities for higher and adjacent units)
- c. Attachments and Detachments (May be published as an appendix, task organization)
- d. Assumptions. (Minimum required for planning purposes)

#### 2. MISSION. (Statement of the overall HSS mission (WHO, WHAT, WHEN, WHERE, AND WHY)

#### 3. EXECUTION.

- a. Surgeon's concept of support. (First, lettered subparagraph provides a concise overview of planned HSS operation and its purpose)
- b. (The second lettered subparagraph identifies the major subordinate headquarters and lists the missions assigned to it)

c. (The third and subsequent lettered subparagraphs identify the remaining major subordinate units in turn and provide their respective mission)

d. Coordinating instructions. (The final lettered subparagraph contains any coordinating instructions that may be appropriate to ensure continuity in HSS)

#### 4. Service Support.

a. Supply. (Refer to SOP or another annex whenever practical)

(1) General Supply. (Provide special instructions applicable to medical units)

(2) Medical supply (Provide special procedures applicable to this operation)

(a) Requirements

(b) Procurement

(c) Storage

(d) Distribution

(3) Health service logistics units. (Give the locations, mission, hours of opening and closing, and troops support for each medical supply unit. An overlay may also be used for clarity)

(4) Salvage of medical equipment and supplies

(5) Captured enemy medical supplies

(6) Civilian medical supplies

(7) Other medical supply matters

b. Transportation and movements (Include medical use of various transportation means)

(1) Ground

(2) Rail

(2) Water (Inland and or sea)

(3) Air

(4) Movement control and traffic regulation

c. Services.

(1) Services to HSS units and facilities. (Include information on the following services: laundry, bath, utilities, fire fighting, construction, real estate, mortuary affairs, and control of patients discharged from hospitals)

(2) Medical equipment maintenance. (Include in separate subparagraphs the location, mission, hours of opening or closing of medical maintenance and or optical repair teams, unless included as attachments to health service logistics units)

d. Labor. (Include policies on the use of civilian or other labor personnel. Comply with existing agreements or arrangements)

e. Maintenance. (Include priority of maintenance, location of facilities, and collecting points)

## 5. EVACUATION, TREATMENT, HOSPITALIZATION, AND OTHER HEALTH SERVICES

a. Evacuation.

(1) Evacuation of patients from the United States uniformed services (Army, Navy, Air Force, Marines, or Coast Guard), DOD civilians, allied forces, coalition forces, EPW, US national contract personnel, indigenous and third country civilians, detainees, internees, others.

(2) Requirements. (List requirements, including percentage evacuated by air or sea transportation means.

(3) Units. (Give location, mission, and attachments for each subordinate evacuation unit)

(4) Evacuation policy. (Provide evacuation policy by phases of the operation.

b. Treatment and hospitalization.

(1) Policies. (State treatment and hospitalization policies, to include civilians and EPW)



(2) Units. (Under separate subparagraphs for each hospital/treatment facility, give location, mission, hours of opening or closing, and attachments)

(3) Dispensary services. (Under separate subparagraph, give location, mission, hours of opening or closing, and troops supported)

c. Other health services. (Include blood management; medical laboratory, dental, veterinary, PVNTMED, and CSC services; and required command, control, communications, computer, and intelligence)

6. MISCELLANEOUS. (Address areas of support not previously mentioned which may be required or needed by subordinate elements in the execution of their respective HSS mission: command post locations, signal instructions, medical intelligence, claims, special reports that may be required, and international or host-nation support agreements affecting HSS)

/s/

Commander/Command  
Surgeon

Annexes:

Distribution:

**Author's Note:** It is important to note that the Navy format is considerably more detailed, but the Army planning method requires that each HSS entity make its own plan, e.g. mental health, dental, veterinary, to supplement the general plan. Further, the security classification of any operational estimate or plan must be written at the top and bottom of each page in the document.

**APPENDIX D. IMPORTANT JOINT UNIVERSAL LESSONS LEARNED,  
AND LETTER GRANTING THE AUTHORS PERMISSION TO USE  
UNCLASSIFIED JOINT UNIVERSAL LESSONS LEARNED**

<u>Title</u>	<u>Database Number</u>
Interagency Planning	10829-67459
(Medevac)	60837-95774
(Medevac)	60836-94728
(Record Keeping)	70638-40582
Joint Medical Terminology	
(Echelons of Care)	LL7F0-03448
(Personnel MOS's, NEC's, AFSC's)	60928-61167
(Personnel)	12559-53418
Pets/Evacuation	LL7F0-02332
Command and Control	
(Contingency Medical Organization)	LLCC0-01884
(Special Medical Conditions)	LL7F0-02331
(Deployment of Medical Assets by Non-Medical Planners)	42734-93030

From: TJSTOCKTON@aol.com[SMTP:TJSTOCKTON@AOL.COM]  
Sent: Friday, November 16, 2001 1:19:36 PM  
To: navylessons@nwdc.navy.mil  
Subject: PERMISSION TO USE UNCLASS LESSONS LEARNED

Ms. Kaplan (or to whom it may concern),  
As per our phone conversation of 16 November 2001, I request  
written permission to use UNCLASSIFIED Navy lessons learned in  
my thesis work on Military Operations other than War.

Thank you,

V/R

LT. Tony Stockton, USN

Graduate Student, Naval Postgraduate School

Monterey, CA. 93940

Subj: **RE: PERMISSION TO USE UNCLASS LESSONS LEARNED**

Date: 11/19/01 8:17:03 AM Pacific Standard Time  
From: *bolger@nwdc.navy.mil (Bogle, Ronald)*  
To: *tjstockton@aol.com ('tjstockton@aol.com')*  
CC: *russellw@nwdc.navy.mil (Russell, William Mr.)*

I am the Program Manager for the NLLS. You have permission to use the unclassified Navy Lessons Learned for your research and thesis. If permissible and you agree, would you forward a copy of your thesis after it's approved? We don't get many requests in the area of MOOTW.

Ron Bogle

NLLS PM  
NWDC Dept N59  
SIMS Hall  
686 Cushing Road  
Newport, RI 02841  
401-841-1126  
[bogler@nwdc.navy.mil](mailto:bogler@nwdc.navy.mil)

## LIST OF REFERENCES

- Bonn, K. E., & Baker, A. E. (2000). Guide to Military Operations Other Than War: Tactics, Techniques & Procedures for Stability & Support Operations—Domestic & International. Mechanicsburg, PA: Stackpole
- Bunker, Robert J. "Rethinking OOTW," *Military Review*: 34–41 (November–December, 1995).
- Davis, L. M., & Hepler, G., & Hosek, S. D., & Perry, M., & Steinberg, P. S., & Tate, M. G. (1996). Army Medical Support for Peace Operations and Humanitarian Assistance. Santa Monica, CA: Rand.
- Davis, L. M. (December 1998). Growing Pains. Armed Forces Journal International, p. 22-26.
- Department of the Army. Operations. FM 3-0. Washington: HQ U.S. Army, June 2001.
- Department of the Army. Planning for Health Service Support. FM 8-55. Washington: HQ U.S. Army, September 1994.
- Department of Defense. Armed Forces Staff College. The Joint Staff Officer's Guide, 2000. AFSC Pub 1. Washington DC: Government Printing Office.
- Department of Defense. Joint Staff. Doctrine for Joint Operations. Joint Pub 3–02. Washington DC: Joint Chiefs of Staff, 1 Feb 95.
- Department of Defense. Joint Staff. Joint Doctrine for Military Operations Other Than War. Joint Pub 3–07. Washington DC: Joint Chiefs of Staff, 1 June 95.
- Department of the Navy. Health Service Support Operations. MCWP 4-11.1. Quantico, VA: Marine Corps Combat Development Command, March 1998.
- Department of the Navy. Health Service Support. FMFM 4-50. Quantico, VA: Marine Corps Combat Development Command, September 1990.
- Department of the Navy. HA: Multiservice Procedures for Humanitarian Assistance Operations. FMFM 7-16. Quantico, VA: Marine Corps Combat Development Command, October 1994.
- Gauker, E. D., Covey, D.C., Emens-Hesslink, K. E., Moya, N. L., & Konoske, P. J. A Descriptive Analysis of Patient Encounter Data from the Fleet Hospital FIVE Humanitarian Relief Mission in Haiti. *Military Medicine*, Vol. 165 (May 2000).

Keohane, R. O. & Nye, J. S. (1989). Power and Interdependence. (2<sup>nd</sup> Ed). (Preface, Chapter 1 & 2). New York: HarperCollins.

Kennedy, P. (1989). The Rise and Fall of the Great Powers: Economic Change and Military Conflict from 1500 to 2000. New York: Random House.

Peay, J. H. B. III. "Correlating Medical Forces Forward," *Joint Forces Quarterly*: 70,71 (Winter 1996).

Taw, Jennifer M., and John E. Peters. *Operations Other Than War, Implications for the U.S. Army*. Santa Monica CA: RAND Publishing, 1995 (MR-556-A).

Weddle, M., & Prado-Monje, H. The Use of Deployable Military Hospitals after Hurricanes: Lessons from the Hurricane Marilyn Response. *Military Medicine*, Vol. 165 (May 2000).

## BIBLIOGRAPHY

- Center for Naval Analyses. (Feb 1999). Peacemaking, Complex Emergencies, and Disaster Response: What Happens, How Do You Respond? (Publication No. CRM 98-176/February 1999). Alexandria, VA: McGrady, E. D.
- Department of Navy, Planning. Marine Corps Doctrine Publication 5. (1997). Quantico, VA.
- Gauker, E. D., Covey, D.C., Emens-Hesslink, K. E., Moya, N. L., & Konoske, P. J. A Descriptive Analysis of Patient Encounter Data from the Fleet Hospital FIVE Humanitarian Relief Mission in Haiti. *Military Medicine*, Vol. 165 (May 2000).
- Hughes, D.A., Hohner, J. A., & Jones, J. Mental Health Nursing Support during Operation Sea Signal: Cuban/Haitian Humanitarian Mission. *Military Medicine*, Vol. 163 (June 1998).
- Naval Medical Research and Development Command. (1996). The Field Hospital at Zagreb: A Database for Military Medical Resource Planning in Operations Other Than War. (Naval Health Research Center Report No. 96-24). Bethesda, MD: Reed, R. J., Martino, J., & Pugh, W. M.
- Oakley, R., & Bentley, D., (May 1995). Peace Operations: A Comparison of Somalia and Haiti. National Defense University Strategic Forum [On-line], Nov 01. Available: [www.ndu.edu/inss/strforum/forum30.html](http://www.ndu.edu/inss/strforum/forum30.html)
- Pincus S. H., & Benedek, D. M. Operational Stress Control in the Former Yugoslavia: A Joint Endeavor. *Military Medicine*, Vol. 163 (June 1998).
- Pirnie, B. R., & Francisco, C. M. (1998). Assessing Requirements For Peacekeeping, Humanitarian Assistance and Disaster Relief. Santa Monica, CA: Rand.
- Randolph, L. M. Jr., & Cogdell, M. W. "Medical Dimensions of Joint," *Joint Forces Quarterly*: 90-97 (Spring 1996).
- Reed, R. J., Martino, J., Eyestone, S. M., & Pugh, W. M. The Field Hospital at Zagreb: Tri-Service Medical Care in a Peacekeeping Operation. *Military Medicine*, Vol. 163 (June 1998).
- Reitinger, K. C. (1998). New Tools for New Jobs. [On-line]. United States Naval Institute, Proceedings. Abstract April 1998. Available: [www.pqasb.pqarchiver.com/proceedings/main/doc.html](http://www.pqasb.pqarchiver.com/proceedings/main/doc.html)
- Tata, A. J. "A Fight for Lodgment: Future Joint Contingency Operations," *Joint Forces Quarterly*: 82-89 (Spring 1996).

Turley, G. H. (2001). Prepare For the Most Likely Commitments. [On-line]. United States Naval Institute, Proceedings. Abstract April 2001. Available: [www.pqasb.pqarchiver.com/proceedings/main/doc.html](http://www.pqasb.pqarchiver.com/proceedings/main/doc.html)

United States Joint Chief of Staff, Doctrine for Planning Joint Operations. Joint Publication 5-0. (April 1995).

## INITIAL DISTRIBUTION LIST

1. Defense Technical Information Center  
8725 John J. Kingman Rd, Suite 0944  
Fort Belvoir, VA 22060-6218
2. Dudley Knox Library  
Naval Postgraduate School  
411 Dyer Rd  
Monterey, CA 93943
3. Captain G. Crittenden  
Commanding Officer  
Naval Medical Logistics Command  
Fort Detrick, MD
3. Captain S. Kirshner  
Executive Officer  
Naval Medical Logistics Command  
Fort Detrick, MD
4. CDR. E.F. Smallwood  
Naval School of Health Sciences  
8901 Wisconsin Ave.  
Bethesda, MD 20889-5611