



**Calhoun: The NPS Institutional Archive**

---

Theses and Dissertations

Thesis Collection

---

1999-03

An integrated intranet and dynamic database  
application for International Program Office at Naval  
Postgraduate School

Sumaruddin, Asep

Monterey, California. Naval Postgraduate School

---



Calhoun is a project of the Dudley Knox Library at NPS, furthering the precepts and goals of open government and government transparency. All information contained herein has been approved for release by the NPS Public Affairs Officer.

**Dudley Knox Library / Naval Postgraduate School**  
**411 Dyer Road / 1 University Circle**  
**Monterey, California USA 93943**

<http://www.nps.edu/library>

**NPS ARCHIVE**  
**1999.03**  
**SUMARUDDIN, A.**



DUDLEY KNOX LIBRARY  
NAVAL POSTGRADUATE SCHOOL  
MONTEREY CA 93943-5101





# NAVAL POSTGRADUATE SCHOOL Monterey, California



## THESIS

**AN INTEGRATED INTRANET AND DYNAMIC  
DATABASE APPLICATION FOR INTERNATIONAL  
PROGRAM OFFICE AT NAVAL POSTGRADUATE  
SCHOOL**

by  
Asep Sumaruddin  
and  
Ferit Tolga Ayan

March 1999

Thesis Advisor:  
Second Reader:

James C. Emery  
Daniel R. Dolk

**Approved for public release; distribution is unlimited.**



# REPORT DOCUMENTATION PAGE

*Form Approved*  
OMB No. 0704-0188

Public reporting burden for this collection of information is estimated to average 1 hour per response, including the time for reviewing instruction, searching existing data sources, gathering and maintaining the data needed, and completing and reviewing the collection of information. Send comments regarding this burden estimate or any other aspect of this collection of information, including suggestions for reducing this burden, to Washington headquarters Services, Directorate for Information Operations and Reports, 1215 Jefferson Davis Highway, Suite 1204, Arlington, VA 22202-4302, and to the Office of Management and Budget, Paperwork Reduction Project (0704-0188) Washington DC 20503.

<b>1. AGENCY USE ONLY (Leave blank)</b>	<b>2. REPORT DATE</b> March 1999	<b>3. REPORT TYPE AND DATES COVERED</b> Master's Thesis	
<b>4. TITLE AND SUBTITLE :</b> An Integrated Intranet and Dynamic Database Application for International Program Office at Naval Postgraduate School.			<b>5. FUNDING NUMBERS</b>
<b>6. AUTHOR(S)</b> Sumaruddin, Asep, and Ayan, Ferit Tolga			
<b>7. PERFORMING ORGANIZATION NAME(S) AND ADDRESS(ES)</b> Naval Postgraduate School Monterey, CA 93943-5000			<b>8. PERFORMING ORGANIZATION REPORT NUMBER</b>
<b>9. SPONSORING / MONITORING AGENCY NAME(S) AND ADDRESS(ES)</b> N/A			<b>10. SPONSORING / MONITORING AGENCY REPORT NUMBER</b>
<b>11. SUPPLEMENTARY NOTES</b> The views expressed in this thesis are those of the author and do not reflect the official policy or position of the Department of Defense or the U.S. Government.			
<b>12a. DISTRIBUTION / AVAILABILITY STATEMENT</b> Approved for public release; distribution is unlimited.			<b>12b. DISTRIBUTION CODE</b>
<b>13. ABSTRACT (maximum 200 words)</b> <p>Intranet technologies like web based databases, groupware and e-mail represent the next major stage in the evolution of computing and it is greatly expected that they will increase the return on information technology investments. Almost every organization can benefit from an intranet or extranet. Some of the major benefits of an intranet can be counted as cost effectiveness, simplified system integration and growth, easy extension into WAN, enhanced security, minimized application development and deployment cost, minimized cost of deploying client – server solutions, minimized network management and support costs.</p> <p>Since International Programs Office (IPO) has several computers connected to a LAN and has an IP address, and one of its tasks is to maintain the International Students' records, they should have a good Database System that can be accessed by all the users of the office. To solve the inefficiency and ineffectiveness that relates to database system that depends on International Students Assistant, we recommend that IPO has to have an intranet system with a dynamic database connectivity. Intranet may solve the communication problem to share information within the organization and may provide better services for the other users.</p>			
<b>14. SUBJECT TERMS</b> Internet Technology, Intranet, Database Management System, International Program Office, Web based Application, Cold Fusion Software Application			<b>15. NUMBER OF PAGES</b> 144
			<b>16. PRICE CODE</b>
<b>17. SECURITY CLASSIFICATION OF REPORT</b> Unclassified	<b>18. SECURITY CLASSIFICATION OF THIS PAGE</b> Unclassified	<b>19. SECURITY CLASSIFICATION OF ABSTRACT</b> Unclassified	<b>20. LIMITATION OF ABSTRACT</b> UL





Approved for public release; distribution is unlimited

**AN INTEGRATED INTRANET AND DYNAMIC DATABASE APPLICATION  
FOR INTERNATIONAL PROGRAM OFFICE AT NAVAL POSTGRADUATE  
SCHOOL**

Asep Sumaruddin  
Major, Indonesian Air Force  
B.S., Indonesian Air Force Academy, 1984

Ferit Tolga Ayan  
Lieutenant JG, Turkish Navy  
B.S., Turkish Naval Academy, 1993

Submitted in partial fulfillment of the  
requirements for the degree of

**MASTER OF SCIENCE IN INFORMATION TECHNOLOGY MANAGEMENT**

from the

**NAVAL POSTGRADUATE SCHOOL  
March 1999**



## ABSTRACT

Intranet technologies like web based databases, groupware and e-mail represent the next major stage in the evolution of computing and it is greatly expected that they will increase the return on information technology investments. Almost every organization can benefit from an intranet or extranet. Some of the major benefits of an intranet can be counted as cost effectiveness, simplified system integration and growth, easy extension into WAN, enhanced security, minimized application development and deployment cost, minimized cost of deploying client – server solutions, minimized network management and support costs.

Since International Programs Office (IPO) has several computers connected to a LAN and has an IP address, and one of its tasks is to maintain the International Students' records, they should have a good Database System that can be accessed by all the users of the office. To solve the inefficiency and ineffectiveness that relates to database system that depends on International Students Assistant, we recommend that IPO has to have an intranet system with a dynamic database connectivity. Intranet may solve the communication problem to share information within the organization and may provide better services for the other users.





## TABLE OF CONTENT

<b>I. INTRODUCTION.....</b>	<b>1</b>
A. BACKGROUND.....	1
B. OBJECTIVES.....	2
C. SCOPE AND THE ORGANIZATION OF THE STUDY.....	2
D. CHAPTERS..	3
<b>II. INTERNET OVERVIEW.....</b>	<b>5</b>
A. THE GLOBAL NETWORK.....	5
B. PACKET SWITCHING .....	6
C. THE PROTOCOLS .....	6
D. THE HISTORY OF THE INTERNET.....	7
E. THE EVOLUTION OF THE INTERNET .....	11
F. WORLD WIDE WEB (WWW).....	12
G. THE LANGUAGE OF THE INTERNET: HTML .....	13
H. CHAPTER SUMMARY .....	14
<b>III. INTRANET TECHNOLOGY AND DATABASE BASICS.....</b>	<b>15</b>
A. HISTORY OF INTRANET SYSTEMS.....	15
B. COMPARISONS.....	17
1. Intranet vs. Internet.....	17
2. Intranet vs. LAN.....	18
3. Intranet vs. Extranet .....	19
C. INTRANET PROTOCOLS .....	20
D. IP ADDRESSING AND NAME RESOLUTION METHODS.....	20
1. Hosts.....	21
2. DNS.....	21

3. WINS.....	22
E. AUTHORIZING AND MANAGEMENT OF TOOLS REQUIREMENTS .....	22
F. CLIENT-SERVER DATABASES .....	23
G. DATABASE ADMINISTRATION .....	25
H. DATABASE MANAGEMENT SYSTEM (DBMS) .....	25
I. CHAPTER SUMMARY .....	26
<b>IV. INTRANET AND THE DATABASE CONNECTIVITY.....</b>	<b>29</b>
A. COMMON GATEWAY INTERFACE (CGI) .....	29
1. Introduction .....	29
2. Working Mechanism .....	30
B. SCRIPT LANGUAGES .....	32
C. EVENT-DRIVEN PROGRAMMING MODEL .....	34
D. ACTIVE SERVER PAGES (ASP).....	35
E. ACTIVEX DATABASE OBJECTS (ADO) .....	38
F. COLD FUSION DATABASE APPLICATION.....	38
<b>V. THE NPS INTERNATIONAL PROGRAMS OFFICE (IPO).....</b>	<b>41</b>
A. MISSION.....	41
B. ORGANIZATION .....	42
C. INFORMATION INFRASTRUCTURE .....	43
1. Hardware Components.....	43
2. Network Components.....	44
D. DATA MODEL OF THE EXISTING DATABASE.....	46
E. EXISTING DATABASE MANAGEMENT SYSTEM (DBMS).....	50
F. REDESIGNED DATABASE.....	50
G. THE FACTORS THAT AFFECT THE REDESIGN.....	54
<b>VI. ANALYSIS AND DESIGN .....</b>	<b>55</b>
A. INTRODUCTION .....	55

B. PROCESS DECOMPOSITION MODEL AND DIAGRAM.....	56
C. NETWORK OPERATING SYSTEMS.....	58
1. Windows NT Server .....	58
2. Novell NetWare .....	60
3. Windows 95 .....	60
D. DATABASE SYSTEM.....	61
E. WEB SERVER SOFTWARE .....	62
F. THE APPLICATION SOFTWARE FOR THE DATABASE AND INTRANET CONNECTIVITY .....	63
G. PROTOTYPE DESIGN .....	64
1. Database.....	64
2. IPO Intranet.....	67
3. System Guide.....	68
<b>VII. CONCLUSION.....</b>	<b>69</b>
<b>APPENDIX A. PROPERTIES OF THE DATABASE FIELDS.....</b>	<b>71</b>
<b>APPENDIX B. SYSTEM GUIDE.....</b>	<b>81</b>
<b>APPENDIX C. APPLICATION CODES.....</b>	<b>91</b>
<b>INITIAL DISTRIBUTION LIST.....</b>	<b>133</b>





# I. INTRODUCTION

## A. BACKGROUND

The Naval Postgraduate School International Programs Office (NPS IPO) is responsible for a very important mission at NPS: integration of the international students and their dependents into the life in the U.S.. This is a challenging task, but NPS IPO achieves its goals to a large extent.

The mission of NPS IPO requires a reliable network environment and an easy to manage Database Management System (DBMS). The existing database system is a complete and effective DBMS, but it is not easy to manage. Since the database, which contains the data about the international students, plays a crucial role, it must be the center of the IPO's information infrastructure.

The computers in the IPO are connected with a LAN. The idea behind connecting computers is to share resources such as hard disk space and printers.

Currently, the dissemination of information is not effective in IPO. The IPO personnel find it hard to use and they can't obtain the data they need in their operations. We believe that an intranet system will present the information in a better way so the personnel will be more apt to access the information.

Another problem arises from the chosen database system, Interbase. It is not one of the well-known database systems in the market. There are few people available who know how to deal with problems when they occur.

We expect that by deploying an intranet system with a client-server type database connectivity, this combination will provide an easy access to the information without the

need to install and manage specialized client side software. IPO personnel will be able to access the information they need through their standard web browsers.

Because of the fast paced environment in the IPO, the personnel need an information system, which requires minimum training and maintenance.

## **B. OBJECTIVES**

The objectives of this thesis are:

1. To design an Intranet System for the IPO
2. To design a database interface that will support the access of the user to the underlying database with the help of a browser
3. To supply the integration of the proposed Intranet and the Database systems

## **C. SCOPE AND THE ORGANIZATION OF THE STUDY**

This thesis has two foci. The first one is about the intranet systems and the second one is about active web database connectivity. Actually, these two subjects are related to each other, so our efforts to develop a solution for the IPO will require a complete combination of these two topics.

The main steps for our thesis are as follows:

- Search and review of the sources related to the topics above
- Do a requirements analysis of the proposed system
- Design the overall structure of the proposed solution
- Import the existing database to the new chosen database system
- Define the solution for an Intranet system

- Define the method(s) for database connectivity
- Integrate the Intranet and the database systems

A wide range of subjects, including ASP, Script Languages, CGI, ADO, ADC, Client-Server Model, ODBC, Relational Database Systems (comparisons between MS Access, MS SQL Server, miniSQL, mySQL) ActiveX Controls, SQL, HTML, CFML, Network Operating Systems, and other network-related topics will be examined.

#### **D. CHAPTERS**

This section provides an outline of the different parts of this thesis that explores the general concept of intranet technology and the specific client application to process the database system in the IPO.

- Chapter I: Introduction - provides a brief description of IPO responsibilities, the objectives of this thesis, and the scope and the organization of the study.
- Chapter II: Internet Overview - explores the global Internet technology system and its evolution and revolution, and describes how it is different from WWW.
- Chapter III: Intranet Overview - provides the basic idea of intranet technology, the comparison to the other technologies, and database management overviews in general.
- Chapter IV: Intranet and Database Connectivity - describes several software applications that can be used in intranet technology to build dynamic database system.
- Chapter V: The NPS International Program Office - provides a brief description of the IPO missions, organization, and information about the current computer system. It also describes the database management system and its problems.



- Chapter VI: Analysis and Design - discusses the decomposition model and diagram to be used in prototyping the dynamic database that will fit to the IPO computer system. It also describes the advantages and disadvantages of several operating systems and the application software for the database and intranet connectivity.
- Chapter VII: Conclusions - briefly describes the need for NPS IPO to establish an intranet based on IPO computer system to distribute data of International Military Student in its database system.

## II. INTERNET OVERVIEW

### A. THE GLOBAL NETWORK

One of the most important innovations of the 20th century has certainly been the establishment of a global network that enables people to reach information in a way that has never been seen before. The name of this global network is the Internet. Actually, the Internet is not one gigantic network that connects all the computers in the world; rather, it is formed by thousands of networks of different sizes, in different geographical locations, using different network architectures, and all connected to one another. For example, a computer in Istanbul, Turkey that is connected to a local network can communicate with a computer in Monterey, California that is connected to NPS network via the Internet. So how does all this happen? The answer is simple. The data that is sent between these two computers passes through a number of different networks until it reaches its destination.

A person, a group, or an organization does not control the Internet. The Internet has the capability of worldwide broadcasting. It is a medium for collaboration and interaction between individuals and their computers without regard for geographic location. It was started as an effort to improve the U.S. military's capabilities in a nuclear attack. Over time, it has evolved into today's huge information warehouse that is open to every person in the world that has a computer, a modem, and a connection to one of the networks that is attached to the global Internet.

## B. PACKET SWITCHING

The Internet is a packet-oriented network. This requires that data to be sent must first be divided into smaller pieces called "packets" and then sent through the Internet. When these packets reach their destination they are re-assembled to form the complete data. If some of the packets are lost on their way, the destination node requests retransmission by the sender node.

The networks that make the Internet are linked together by special devices called "Routers". The main duty of a router is to check the destination of a packet and decide where to send it. Of course not all the routers in the world are completely connected with one another, they just decide which router (s) to send the data to next. Routers try to find the most efficient route based on the traffic.



**Figure 1: Routers**

## C. THE PROTOCOLS

TCP (Transmission Control Protocol) and IP (Internet Protocol) are the core protocols of the Internet.<sup>1</sup> Basically, a protocol is a set of rules that must be followed to ensure a healthy data transfer environment. Each computer attached to the network has at least one

---

<sup>1</sup> [Gopher://gopher-chem.ucdavis.edu/11/index/Internet-aw/Intro\\_the\\_Internet/introto.ip](http://gopher://gopher-chem.ucdavis.edu/11/index/Internet-aw/Intro_the_Internet/introto.ip)

numerical IP address. However, it is hard for a human to remember these numbers (for example 131.120.31.50), so the Domain Name System (DNS) was introduced in 1984.<sup>2</sup> DNS converts the IP address to a URL (Uniform Resource Locator). This is much easier to remember for a human (for example [www.nps.navy.mil](http://www.nps.navy.mil)).

The Internet embodies a key underlying technical idea, namely that of open architecture networking. In this approach, the choice of any individual network technology is not dictated by particular network architecture. As a result, each network can be designed in accordance with the specific environment and user requirements of that network. Usually there are no constraints on the types of network that can be included or on their geographic scope, although there are some certain pragmatic considerations.

#### **D. THE HISTORY OF THE INTERNET**

The birth of the Internet goes back to 1957 when the USSR launched its first satellite around the world.<sup>3</sup> To be able to keep pace with the USSR, the United States formed the Advanced Research Projects Agency (ARPA) to support research in science and technology applicable to the military. The development of information technologies was one of the primary focuses. Below we present a timeline of Internet history.

1961: L. Kleinrock at MIT published the first paper on packet switching technology and the first book on this subject in 1964.

---

<sup>2</sup> Rigney, Steve, [TCP/IP: A Survival Guide](#), p. 3-61.

<sup>3</sup> [Internetvalley.com/intval.html](http://Internetvalley.com/intval.html)

In 1962, Paul Baran from RAND Corporation (America's foremost "think tank" during the Cold War) was commissioned by the U.S. Air Force to study how the U.S. authorities could communicate after a nuclear attack.

1964: Paul Baran's proposal was a packet switched network. This was crucial to the realization of a computer network. If packets are lost at any given point, the message can be resent by the originator. This method was of course inefficient and slow, but very reliable. The way that the packets go is not important; the important thing is whether the packet reaches its destination. Today, the Internet still uses the same paradigm.

1965: ARPA sponsored a study on "cooperative network on time sharing computers".

1967, MIT researcher Lawrence G. Roberts announced his plan for the "ARPANET".

1968: The first packet-switched network was installed in National Research Laboratory in Great Britain. The same year ARPA awarded the ARPANET contract to BBN (Bolt Beranek and Newman). UCLA was selected as the first node of the ARPANET.

1969: The first four nodes of the ARPANET were ready and connected to each other. (UCLA, Stanford Research Institute, UC Santa Barbara, University of Utah)

1970: The Network Working Group working under S. Crocker released the first host-to-host protocol for the ARPANET (Network Control Protocol, NCP).

1971: The number of the nodes reached 15 (23 hosts); also the same year, protocols for Telnet and FTP were defined by NWG.

1972: The first email program was invented by Ray Tomlinson from BBN. This enabled the scientists to use the ARPANET not only for remote computing but also for communication. The first public demonstration of the new network technology happened the same year at the International Computer Communication Conference.



1973: Vint Cerf and Bob Kahn published the basic principles of TCP, on which a protocol was designed to meet the needs of an open architecture network environment.<sup>4</sup> While NCP tended to act like a device driver, the new protocol would be more like a communication protocol. The same year, the first international connections became University College of London (England) and Royal Radar Establishment (Norway). Vint Cerf and Bob Kahn in a paper on TCP first used the term Internet in 1974.

1976: UUCP (Unix to Unix Copy Protocol) was released by AT&T. The same year, The Department of Defense began an experiment with the TCP/IP, and soon decided to require it for use on ARPANET.

1979: BITNET (Because It is Time for Network) was created by IBM.

1981: The National Science Foundation created a backbone called CSNET. (It didn't have an access to the ARPANET at the beginning.)

1983: TCP/IP became the mandatory protocol for the ARPANET and replaced the NCP completely. The University of Wisconsin invented the Domain Name System (DNS), making it easier to reach other users because people no longer had to remember the numeric IP address. Also the same year, Internet Activities Board (IAB) was established.

1984: ARPANET was split into ARPANET and MILNET. MILNET was to serve the needs of the military and ARPANET was to support the advanced research studies.

1986: NSFNET (National Science Foundation Network) was created. Internet Engineering Task Force (IETF) and Internet Research Task Force (IRTF) were established under the IAB.

---

<sup>4</sup> [internetvalley.com/archieves/mirrors/cerf\\_how\\_inet.txt](http://internetvalley.com/archieves/mirrors/cerf_how_inet.txt)



1987: BITNET and CSNET joined to form CREN (Corporation for Research and Educational Networking).

1988: T1 Backbone of the NSFNET was completed. The first Internet virus affected about 6000 hosts in the Internet. CERT (Computer Emergency Response Team) established by DARPA after the lessons learned from the first Internet worm.

1989: *Cuckoo's Egg* by Clifford Stoll told the real story of a German "Hacker".

1990: The ARPANET completed its mission and was replaced by NSFNET backbone. (The construction of the T3 lines continued). Archie released by a group at McGill. (Archie keeps the lists of the files of the FTP sites.)

1991: Wide Area Information Servers (WAIS) was invented by Brewster Kahle. CSNET finished its mission. NSFNET backbone upgraded to T3 (45 Mbps). A security mechanism, PGP (Pretty Good Privacy), was released by Philip Zimmerman. Gopher was released by a group from University of Minnesota.

1992: WWW (World Wide Web) was released by CERN. ISOC (Internet Society) came to life. Veronica, a gopherspace search tool, was released by University of Nebraska.

1993: InterNIC was established to provide some specific Internet Services. Mosaic, the first GUI to the WWW was developed by Marc Andressen at the University of Illinois.

1994: ATM (Asynchronous Transmission Mode, 145 Mbps) backbone replaced the old T3 backbone of the NSFNET. The first electronic shopping malls appeared on the Internet.

1995: NSF declared that it would not allow direct access to the backbone as of April 30. NSF contracted with four companies that would be providers to the NSF Backbone. These four companies would have the right to sell connections to other parties. NSFNET

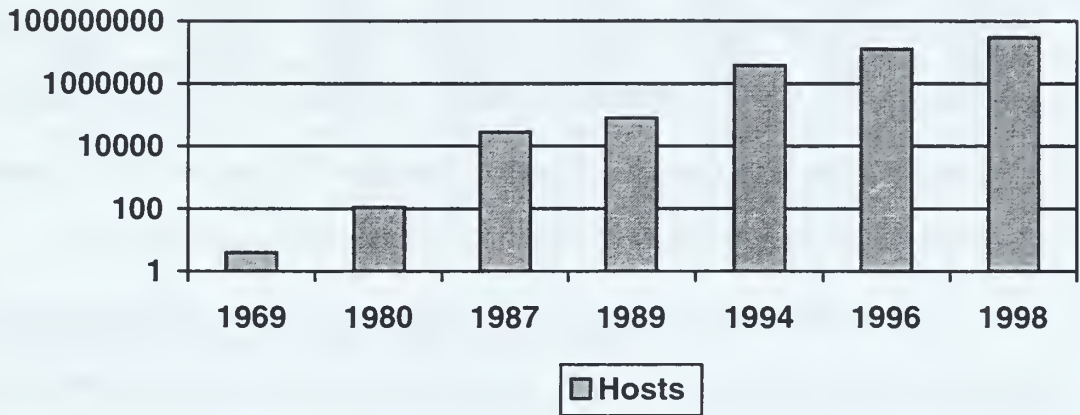
continued its life as a research network. An annual fee was imposed for domain names except “edu” and “gov”.

1996: The Majority of the Internet traffic carried by backbones of the independent ISP's (MCI, AT&T, Sprint, Uunet, etc.). MCI upgraded its backbone from 155 Mbps to 622 Mbps.

1997: The war between browser companies continues (Microsoft Internet Explorer and Netscape Navigator). Studies on Ipv6 (next generation IP) continue.

### E. THE EVOLUTION OF THE INTERNET

The growth in the number of the hosts in the Internet is shown in Figure 2:



**Figure 2: Historical growth of Internet hosts (logarithm scale)**

The Internet is continuing to grow in a rapid manner as of the number of hosts connected, new technologies applied and new innovative ways to use it. The Internet has

involved from a useful tool for the scientific community into a network for anyone who has access to use it. At the present time, it is used mostly for the commercial purposes.

The high rate of growth of the Internet has brought with it the problems. These problems can be categorized in two parts: technical and managerial. The existing backbone can hardly keep up with the increasing traffic, so it needs to be enhanced by new technologies that offer a better solution. During the developing days of the Internet, the efforts of volunteers could settle most problems, but now it faces much more complicated problems that require more formal management. The most important question for the Internet's future is not the technological change, but rather how to manage it.

## **F. WORLD WIDE WEB (WWW )**

Most people think that Internet is the same thing as the World Wide Web (WWW). They are not identical, however. WWW is basically a GUI that uses the hypertext concept as programmed in HTML (Hypertext Markup Language). Actually, HTML is not a programming language, but rather a mark up language that uses the HTML commands (Tags) to design the appearance of a Web page. The current version is HTML 4.0.

The WWW was invented at CERN Research Institute, Switzerland in 1992, by a group headed by Tim Berners-Lee.<sup>5</sup> Berners-Lee also wrote the first WWW client and the first WWW Server and defined the standards such as URL, HTML, and HTTP.<sup>6</sup>

One of the key components of the WWW is the browser. Browsers are the programs that enable the user to view the HTML-based Web pages. The first popular browser was

---

<sup>5</sup> Cem.ch web site.

<sup>6</sup> w3.org/People/Berners-Lee/ShortHistory.html

NCSA Mosaic released in February 1993. One of the inventors of Mosaic, Marc Andreessen, later founded his own company ( Netscape ) and released Netscape Navigator. Microsoft Company decided to enter the browser race and released its own browser, Internet Explorer, for free.

Pages that are created for WWW should reside in a Web Server. When a browser makes a request for a page, the Web Server pulls the page out of its directories and sends a copy of it to the browser.

WWW is the fastest growing part of the Internet. Figure 3 shows the rapid increase in the number of Web Sites.

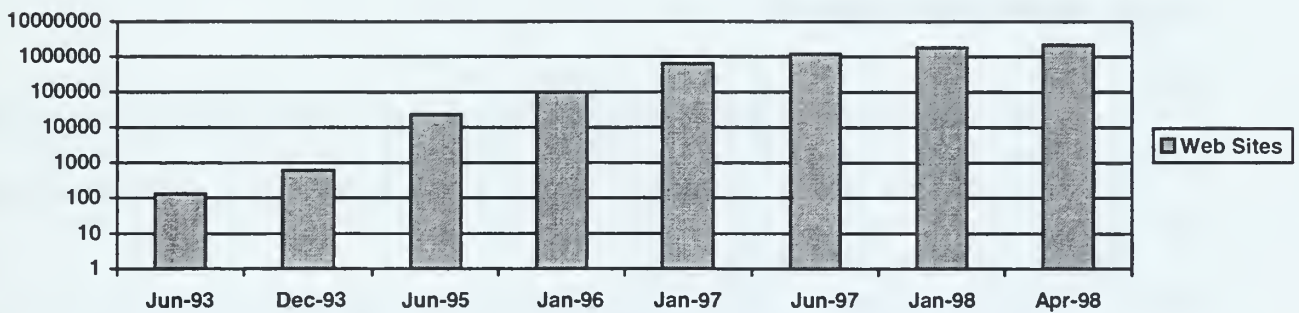


Figure 3: Growth in Web Sites (logarithm scale)

## G. THE LANGUAGE OF THE INTERNET : HTML

By inserting the HTML tags into a normal document, one can easily convert that document into an Internet document. HTML is very easy to learn and use. Any type of editing environment can be used to create HTML documents (There are also many special programs that make this process easier, like MS Frontpage).

There are a lot of “tags” to use, but only three of these tags are required. <HTML>, <HEAD> and <BODY> tags are required to display a WWW document. Other tags are used to control the format of the document.

A standard committee called the World Wide Web consortium governs HTML. Any changes or proposed changes to the HTML language are posted to the consortium’s web page. ([www.w3.org](http://www.w3.org))

Not all of the HTML tags are supported by every browser. To be able to create a web page that can be seen by everyone, only the tags that are supported by every browser should be used.

## **H. CHAPTER SUMMARY**

The Internet has completely changed our lives. Information that used to be available only to a lucky few is now available for anyone having a connection to the Internet and a computer with a modem and a browser.

In the near future, as new technologies appear, the effects of the Internet will be more dramatic. The mechanisms that we use today for commerce, banking and all the other branches of the service sector will need to be redefined for the new Internet age.



### III. INTRANET TECHNOLOGY AND DATABASE BASICS

An “intranet” is essentially a private Internet operating on an organization’s internal network. Nowadays, many companies use an intranet as a primary medium to deliver private corporate information to internal users because it offers several benefits to an organization. These include the ease of sharing information between connected computers, the ability to develop applications that support heterogeneous platforms throughout an organization (i.e., varying operating systems and hardware architectures), common user application interfaces, and e-mail and browsers.<sup>7</sup>

Even though intranet is not connected to Internet, there is no such thing as a totally secure intranet. An intranet, and any data that passes through it, is vulnerable to attack. Providing the appropriate levels of access and security on an intranet, along with flexibility to grow and change, is an important consideration. Threats can come from inside the intranet or from any connected, external networks, including the Internet. Various studies have indicated that the majority of threats (80 to 95 percent) come from within the internal network.<sup>8</sup>

#### A. HISTORY OF INTRANET SYSTEMS

There is little doubt that intranet technology is revolutionizing corporate computing, providing a bold new infrastructure for communication. As quickly as corporate bandwidth

---

<sup>7</sup> Levitt, Lee, “Intranets: Internet Technologies Deployed Behind the Firewall for Corporate Productivity”, prepared for Internet Society INET’96 Annual Meeting.

<sup>8</sup> Ambegaonkar, Prakash, “Intranet Resource Kit”, p. 350, Osborne McGraw-Hill, California, 1997.



expands, audio and video applications are waiting to devour it. The real challenge is in managing fast-growing Intranets for maximum corporate advantage.<sup>9</sup>

In a recent Forrester Research Inc. survey of executives at 50 Fortune 1000 companies, 96 percent of those polled were either building or already using internal Web sites. Only 4 percent had no plans to invest in intranet technology. Other surveys indicate that 65 percent to 90 percent of America's biggest corporations expect to implement intranets by the end of this year.<sup>10</sup>

The PC revolution of the late 1980's and early 1990's created a large base of networked Personal Computers (PC) in the American corporate environment. Businesses created Local Area Networks (LANs) and Wide Area Networks (WANs) to connect computers across all parts of the organization.

Now, every new operating system or computer sold in retail stores is equipped with basic tools like Web browsers, TCP/IP networking, and other Internet components included as standard features, or easy add-ons. Because of these developments, we are already seeing a second Internet revolution - one that promises to bring true and lasting benefits to the enterprise by bringing the information superhighway in-house.<sup>11</sup>

An important concept to remember about intranets is that an Internet connection is not required. All you need is a network and a set of desktop computers running the correct protocols and software that enable the intranet to operate. An Intranet allows instant,

---

<sup>9</sup> <http://www.intranets>

<sup>10</sup> [http://www.cio.com/WebMaster/sem1\\_why\\_use.html](http://www.cio.com/WebMaster/sem1_why_use.html)

<sup>11</sup> Bernard, Ryan, The Corporate Intranet, p. 7, John Wiley & Sons, Inc., Canada, 1996.

random, and totally unfettered point-to-point communication between any two nodes on a network without login, setup, or special programming.<sup>12</sup>

More powerfully, intranet technology promises to liberate many traditional mainframe and client-server applications by allowing easy access to data from any node on the network. Instead of creating special programs to access a company's product database, for instance, one can quickly create a web front-end that gives any user instant-access at the click of a button.<sup>13</sup>

## **B. COMPARISONS**

### **1. Intranet vs. Internet**

Intranets exploit the incredibly popular and low-cost Internet tools to gain strategic advantage over competitors, cut cost, and improve operational effectiveness. An Intranet typically has three features lacking on the Internet:

- Speed – broad bandwidth
- Security – private internal network (LAN/WAN), protected from Internet users by a firewall.
- Control – Enterprise network management to ensure reliability

An intranet can be viewed as an information utility for an enterprise. It does not matter whether you are using a Mac, Windows or a UNIX workstation – the user can plug in to the intranet and find the desired information, from documents to e-mail to data to audio

---

<sup>12</sup> Ibid, p.14.

<sup>13</sup> Ibid, p. 16.

and video. Corporate and department information is accessed via the standards of the Internet: e-mail (SMTP), WWW, file transfer (ftp), and other Internet services.

Typically, larger enterprises allow connection outside of the intranet to the Internet through firewall servers that have the ability to screen messages in both directions so that company security is maintained.<sup>14</sup>

## **2. Intranet vs. LAN**

The term LAN is most often used to refer to networks created out of a certain class of networking equipment which is tailored to communication over a short distance. LAN-style networking equipment typically transmits data at a higher rate than WAN-style equipment: the equipment's design takes advantage of the short distance to supply a high transmission rate at a relatively low cost.

Note that both LAN and WAN equipment typically offers faster data transfer than even the fastest ordinary modem/phone-line access, LAN transfers being on the order of 10 times faster. This means graphics that are loaded through the network can be displayed significantly faster, and there are things that are practical to do on a LAN that one would never do with a modem. For example, you might set up your computer to load your word processing application through the LAN rather than from hard disk; the time you have to wait while it loads would be similar (a few seconds) in either case. In contrast, loading such an application through a modem might require minutes or hours.

A typical use of a LAN is to tie together personal computers in an office in such a way that they can all use a single printer and a file server. A file server is a computer set up

---

<sup>14</sup> <http://www.intrack.com/intranet/iarchi.shtml>

so that other computers can access its hard disk as if it were their own. LANs are also used to transmit e-mail between personal computers in an office, or to attach all the personal computers in the office to a WAN or to the Internet.

There is some variation in the way the term LAN is used:

- It is used to refer to a file server and printer, and often the personal computers that are tied to them. People refer to saving their files on the LAN, or on the PC LAN.
- It is used more specifically to refer to the data communications wiring and equipment that ties the personal computers to the file server and the printer.

### **3. Intranet vs. Extranet**

An extranet is a private network that uses the Internet protocols and the public telecommunication system to securely share part of a business's information or operations with suppliers, vendors, partners, customers, or other business. An extranet can be viewed as part of a company's intranet that is extended to users outside the company. It has also been describe as a "state of mind" in which the Internet is perceived as a way to do business with other companies, as well as to sell products to customers. The same benefits that HTML, HTTP, SMTP, and other Internet technologies have brought to the Internet and to corporate intranets now seem designed to accelerate transactions between businesses.

Companies can use an extranet to:

- Exchange large volumes of data using Electronic Data Interchange (EDI)
- Share product catalogs exclusively with wholesalers or those "in the trade"
- Collaborate with other companies on joint development efforts
- Jointly develop and use training programs with other companies

- Provide or access services provided by one company to a group of other companies, such as an on-line banking application managed by one company on behalf of affiliated banks
- Share news of common interest exclusively with partner companies

### **C. INTRANET PROTOCOLS**

Intranets are already being used by many companies to deliver private corporate information to internal users. As we mentioned above, an intranet is any internal network (LAN or WAN) that supports Internet applications -- primarily web (hypertext transfer protocol), but also other applications such as FTP (file transfer protocol).

An intranet uses TCP/IP, HTTP, and other Internet protocols and in general looks like a private version of the Internet. With networking, companies can send private messages through the public network, using the public network with special encryption/decryption and other security safeguards to connect one part of their intranet to another.

Typically, a network must have TCP/IP connectivity before an intranet will be possible. If a network has TCP/IP, one can easily install web servers and browsers that work the same way they do on the World Wide Web.<sup>15</sup>

### **D. IP ADDRESSING AND NAME RESOLUTION METHODS**

In TCP/IP naming and addressing can be somewhat confusing, unless several basic conventions and concepts are understood. The Central Authority is responsible for naming all networks, which will be interconnected into an Internet. The Network Information Center



(NIC) is responsible for assigning values and attributes to the overall Internet. For small internets, this might also be the Network Administrator for the networks.

In order to make it easier for users, TCP/IP supports a hierarchical naming system to allow names to be assigned to machines and networks. The Internet defines several high-level domains. Commercial sites, such as most companies, belong to the com domain. A site name can cover more than one network ID.<sup>16</sup>

## 1. Hosts

A host is any device connected to a TCP/IP network that does not forward datagrams between networks. Traditional TCP/IP terminology identifies only hosts and gateways (IP routers). Most hosts support the protocol stack up through the application layer.<sup>17</sup> It means that the host provides TCP/IP layers as in OSI model layers, Data Link Layer, Network Layer, Transport Layer, Session Layer, Presentation Layer, and Application Layer.

Generally speaking, a host is a computer system that contains the necessary software and hardware so that it can connect and operate in a network environment. In the IBM world, a host is a mainframe or a Central Processing Unit.<sup>18</sup>

## 2. DNS

Domain Name Service is used by TCP/IP to map hostnames to IP addresses. It is implemented through the interaction of two components, the name resolver and the name server. The resolver is client software on a user's computer that queries domain name servers, normally to translate domain names into IP addresses. The domain name server is a

---

<sup>15</sup> [http://www.intramark.com/resources/sem\\_1.html](http://www.intramark.com/resources/sem_1.html)

<sup>16</sup> Reed, Kenneth, *Data Network Handbook*, p. 137, Van Nostrand Reinhold, New York, 1996.

<sup>17</sup> Hunt, Craig, *Networking Personal Computers*, p. 357, O'Reilly & Associate, Inc., California, 1995.



program that accesses a database of domain and host names and their associated IP addresses from which it answers queries from resolvers.<sup>19</sup>

### 3. WINS

Windows Internet Name Service (WINS) is a protocol developed by Microsoft to make resolving Internet numeric addresses easier in a local area network. WINS performs the function of mapping Microsoft networking names to the numeric representation of the Internet number. WINS is designed for keeping track of Microsoft-style computer names in a LAN.

## E. AUTHORING AND MANAGEMENT OF TOOLS REQUIREMENTS

The sheer volume of information stored by corporations today-- including reams of printed information like computer documentation, procedures, specifications, and reference documents -- argues for taking information on-line. Users will no longer wade through a shelf full of documentation, and companies can no longer justify the cost of printing all this information without a guarantee that users are actually reading it. Much of the information provided is not used because it is too hard to access, and when it is accessed it is often out of date.

An intranet should be justified on the basis of the services or suite of services it will offer its users. These services will help dictate the required server hardware and software, and even the client software.

---

<sup>18</sup> Reed, Kenneth, Data Network Handbook, p. 337, Van Nostrand Reinhold, New York, 1996.

<sup>19</sup> Washburn, Kevin and Evans, Jim, TCP/IP running a successful network, 2<sup>nd</sup> edition, p. 356, Addison-Wesley, England, 1996.

The overall responsibility for the creation and maintenance of intranet servers and services belongs to an organization's webmaster. A webmaster typically maintains the functionality of the intranet services provided. In addition, the Webmaster is responsible for updating the content of the Web sites as well as keeping up-to-date on current Web technologies and services.<sup>20</sup>

## **F. CLIENT-SERVER DATABASES**

The Client-Server Database System Architecture is the basis for most work-group database processing today. It involves multiple computers connected in a network, in which some computers process application programs and are designated as clients while others process the database and are designated as servers.

Any computer can be a client or server, but because of cost considerations the client and the server are often a microcomputer. Sometimes the server is a mini or mainframe when considerable power is required from the server or, for political or organizational reasons, it is inappropriate to locate the database on a microcomputer. The clients and servers are generally connected together using a local area network (LAN).<sup>21</sup>

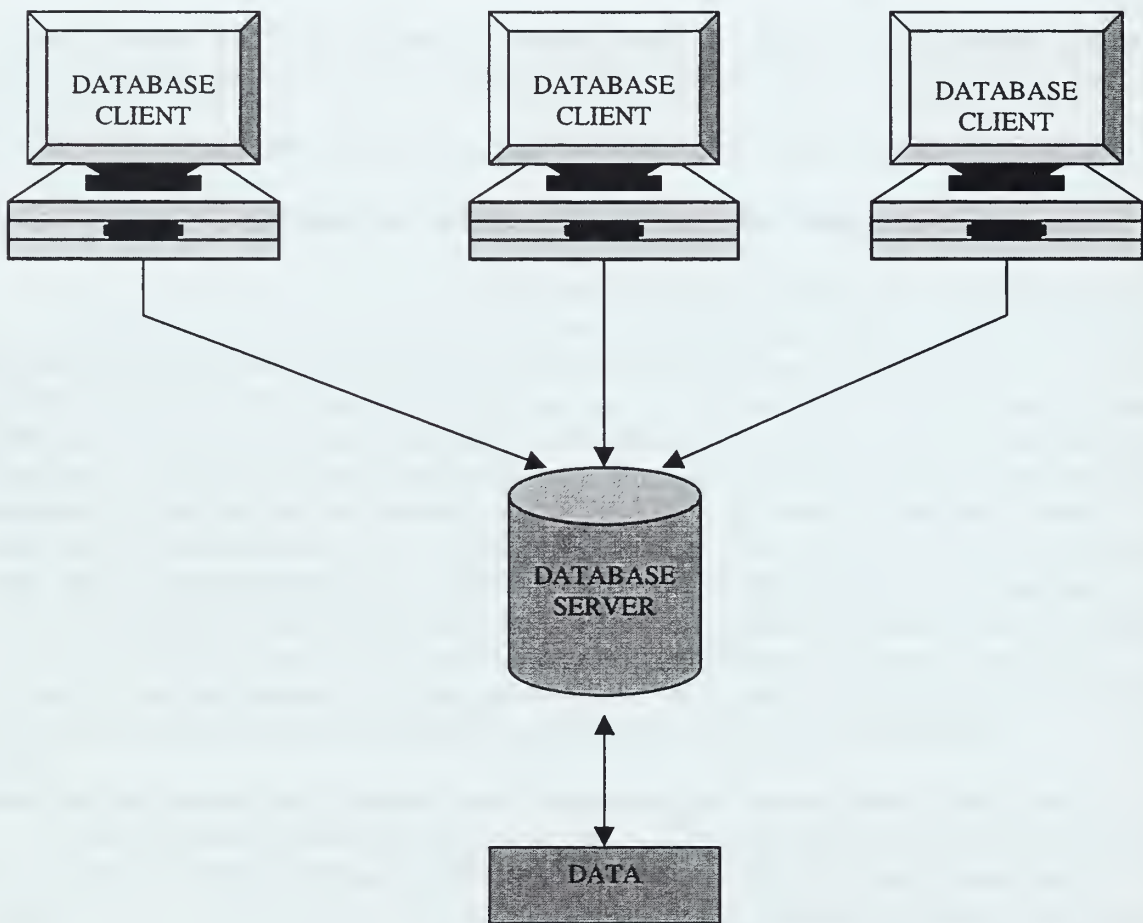
Multiple servers may process different databases or provide other services on behalf of the clients. When two servers process the same database, the system is no longer called a client server-system; rather, it is termed a distributed database system. A server accepts a client's request, processes it, and returns a response.

---

<sup>20</sup> Ibid, p.16.

<sup>21</sup> Ibid, p.483.

One advantage of client-server is better performance, because several CPUs can process applications in parallel. Application programs are distributed to the client computers, and the database is processed by the server computer.



**Figure 4: Client/ Server database model**

## **G. DATABASE ADMINISTRATION**

Database administration operates within the framework provided by data administration to facilitate the development and use of a particular database and its applications. The overall responsibility of the Database Administrator is to facilitate the development and use of the database within the context of guidelines set out by data administration. Usually this means balancing the conflicting goals of protecting the database and maximizing its availability and benefit to users.

The Database Administrator is also responsible for the development, operation, and maintenance of the database and its applications; specifically:

- Managing the database structure
- Managing data activity
- Managing the Database Management Systems
- Establishing the database data dictionary
- Providing for database reliability
- Providing for database security

## **H. DATABASE MANAGEMENT SYSTEM (DBMS)**

A DBMS is special software to create and maintain a database, and enable individual business application to extract the data they need without having to create their own files or data definitions. A DBMS eliminates most of the data definition statements found in traditional data files/programs, such as:

- Data redundancy and inconsistency occur when different divisions, functional areas, and groups in an organization independently collect the same piece of information.<sup>22</sup>
- Using traditional data files the programmer would have to define the data and then tell the computer where they are.

The DBMS contains features essential to a multi-user environment. The primary functions of a DBMS are storing, retrieving, and modifying data. Other features include controlling concurrent processing, providing backup and recovery services, and providing facilities to establish an appropriate level of database security.

## I. CHAPTER SUMMARY

Building an effective Intranet means thinking about how documents can be used to accomplish tasks, how tasks can be organized into processes, and how those processes can be carried out collaboratively by virtual work groups. An effective intranet is not only a tool; it is also a model for an efficient, process-centered enterprise -- a machine for doing business.

A truly effective intranet creates new channels of communication that overcome inefficient organizational structures and foster new forms of efficient collaboration. It serves as a model for a company centered around processes rather than departments, collaboration rather than closed doors.

To effectively design, deploy, and support an Intranet within an organization, the person in charge must have:

- A clear understanding of the challenges involved

---

<sup>22</sup> Laudon, Kenneth C. and Jane P., Essential of Management Information Systems: Organization and Technology, 2<sup>nd</sup> edition, p.202, Prentice Hall, New Jersey, 1997.



- A cross organizational plan for its use
- A technical strategy in support of this plan
- A client and information deployment strategy
- A support tools and services

Since the main purpose of an intranet is usually to share company information and computing resources among employees, building an intranet for IPO can ease problem of ineffective information creation and exchange, as we mentioned in Chapter I. It will allow employee in IPO to contribute the different skills necessary to carry out a particular process.

As we understood that one of IPO tasks is to maintain the data of international students in a database application, it can be maintained by putting database in IPO an intranet as a dynamic database with Cold Fusion as a client. It will be described in the next chapter.





## IV. INTRANET AND THE DATABASE CONNECTIVITY

### A. COMMON GATEWAY INTERFACE (CGI)

In this chapter, we will mention about the possible ways of combining the IPO database with an intranet system. The DBMS will reside on a database server (International Student Assistant's computer will host the server software) and a web browser software will be the only application program that will be needed for the IPO personnel.

#### 1. Introduction

Dynamic Web Pages, like an on-line store's order page, are not plain, old static HTML files. The dynamic nature of these pages comes from small programs called scripts. Scripts create the required HTML source by combining the different sources of data (user's data, database data, OS data), and presenting these data in a form that web browser software can understand and interpret.

Generally, the scripts that provide these dynamic and interactive environments are not hard to create. The hard part of this process is to understand the complete mechanism of how the scripts work, how they communicate with the Server and the client, and how they create responses.

CGI (Common Gateway Interface) is a gateway that provides a common environment and a group of protocols for the applications to use when they interface with the web server. CGI can be used for any application to interact with the web server.<sup>23</sup>

---

<sup>23</sup> Brenner , Steven , Introduction to Perl / CGI , P.16.

## 2. Working Mechanism

The web server software is responsible for getting information from the client software (browser) and responding to the browser's request, usually by sending a copy of the HTML file that the browser requested. The mechanism can be understood easily by an example. When you type your favorite on-line book store's web address on your browser, you simply make a request to the web server, where all the HTML files (and maybe some other types files) of the book store reside, for a specific file. The first file you see is called as Index Page or Home Page; this page is the beginning point of your surf on that site. If you decide to buy a book, you click the link that takes you to the order page. You fill out the form with such information as credit card number and the delivery address, and click the submit button.

When it receives the order form, the web server notices that it needs to put this information in the database but it does not have the necessary tools to accomplish this task. So it wakes up one of the scripts to help it. The script takes the information from the server and puts it into the database. Usually another script creates a message about the completion of the order. The server takes this message and sends it to the user's browser.

The following scheme shows how the mechanism works:

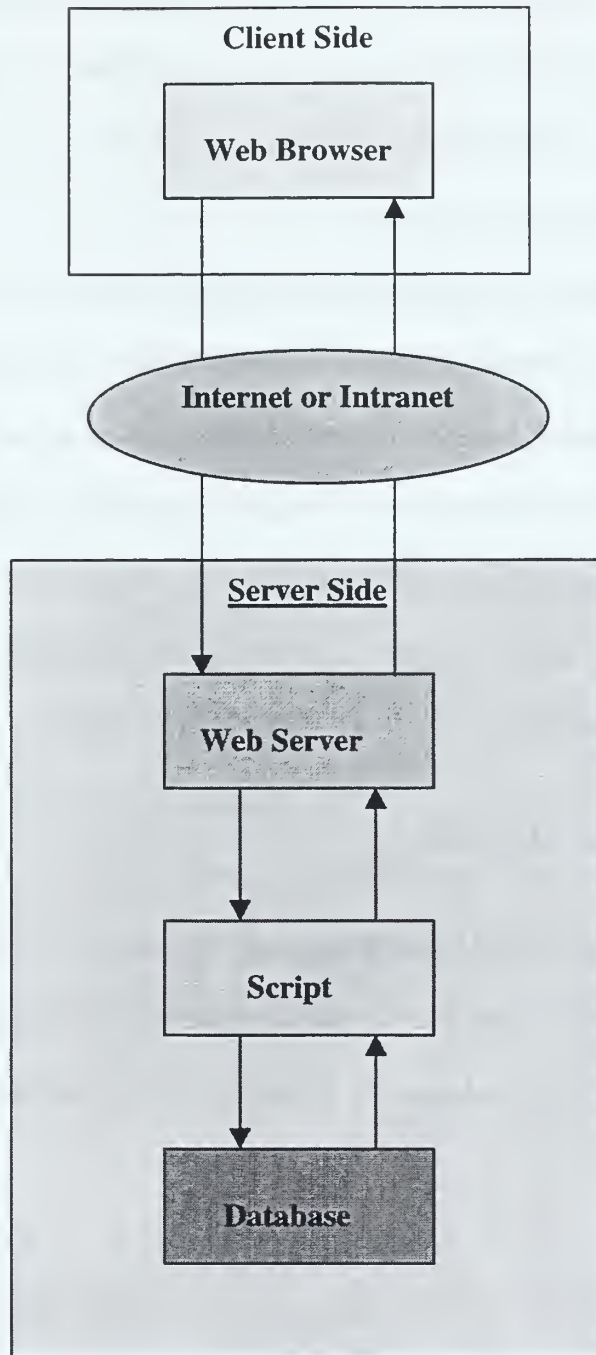


Figure 5: The working mechanism of server side scripts

There are two methods of sending information to a script. These are GET and POST. The method that is chosen will create a difference in how the script will take the information. Actually there is a small difference between the methods, but for some specific applications this difference might be important.

To be able to use CGI scripts, two items are needed: 1. a clear understanding of the scripts' working mechanism, and the security flaws that may arise; 2. a directory in which to store these scripts. Because the scripts are executable programs, special care must be exercised in order not to compromise the security of the system. The scripts must be put into specially configured directories. If the Web Server is a UNIX server, this special directory is usually called as cgibin or cgi-bin. If the Web Server is an NT server then the directory is usually called Scripts.

## **B. SCRIPT LANGUAGES**

Almost any programming language can be used to write a script; however some languages are more preferred by specific Operating Systems. The following list shows the various programming languages for writing a CGI application.

<u>Language</u>	<u>System</u>	<u>Type</u>
Shell	UNIX	Interpreted
Perl	UNIX, Windows Macintosh, Amiga	Interpreted
C	UNIX, Windows	Compiled
C++	UNIX, Windows	Compiled



AppleScript	Macintosh	Interpreted
TCL	UNIX	Interpreted
REXX	OS2, Amiga	Interpreted

There are two basic types of Scripts: Server Side and the Client Side. The type of script you choose depends on the needs of your application. If there is a need to process a user's form input on the server, or to include information from a database, then a server side script must be chosen. If the number of trips to the server can be reduced by adding something on the client side (like a form validator), or if the appearance of the Web Page must be tailored for each of the customers, then client side scripts must be chosen.

The following is a simple script example written in PERL Language. This is just a fragment of a script, not a complete program.<sup>24</sup>

```
-----
If ($weather eq "rainy"){ print "don't forget a raincot.\n "; }
If ($weather =~ /[Rr]ainy/) {#do a regexp match this time print " Hello .\n";
} else {print " Bonjour.\n";
}
-----
```

JavaScript and VisualBasicScript are specifically designed and created for the Internet. JavaScript, despite the Java in its name, is not exactly the same language as Java. Although they have some capabilities in common with inheritance from C++, JavaScript is a light-weight cousin of Java. It is supported by all of the major web browsers. VBScript is a

light version of the VisualBasic language. It is easy to learn and shares most of the properties of VB; only Microsoft Internet Explorer currently supports it. JavaScript and VBScript are both interpreted languages.

There is a difference between an interpreted language and a compiled language. For compiled language code to execute, the whole code must first be translated into machine code, and then executed. A translator called a compiler does this operation. With interpreted languages, the code is translated into machine code on a line-by-line basis. This process is slower than compilation, but generally the scripts written in interpreted languages are small enough so that speed is not an issue.

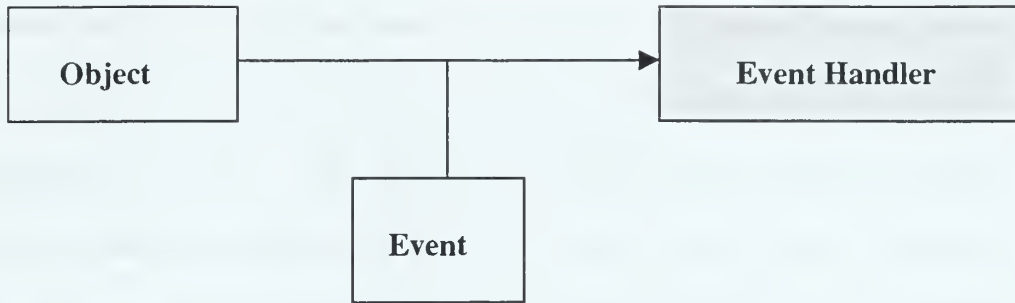
### **C. EVENT-DRIVEN PROGRAMMING MODEL**

The idea behind this model is that an application is directed, or driven, by the events that the user performs. For example, if the user clicks the submit button, he/she will cause an action to take place. The program executes the desired function and after completion returns control to the user. Until the next call by the user, the program sits idle. There are three major components of this mechanism:

1. Object
2. Event
3. Event Handler

---

<sup>24</sup> Brenner, Steven, Introduction to CGI / PERL, P.51.



**Figure 6: Event driven programming model**

An Object can be a submit button on an on-line order form. If the user clicks this button, an event, the form will be sent to the server and it will be stored in a database with the help of a script called an event handler.

There are some benefits of using this model instead of the classical procedural approach. First, the order of the program execution is depend on the choices of the user. Second, when it is not handling something, an event-driven program does not use much of the computer's capacity. Third, it simplifies the programming. The program does not check whether there is input or not; it just waits for the OS to send an event for it to handle.

#### **D. ACTIVE SERVER PAGES (ASP)**

There is another way, in addition to CGI Script, to add information interactivity to HTML pages. A new technique called ASP (Active Server Pages), introduced with the Internet Information Server's third version (Microsoft's Web Server), is another way to add information interactively to HTML pages.

VBScript, JavaScript, Java or PerlScript can be used to create scripts as ASP. The most important feature of the ASP is to customize web pages on the Web Server before they are sent back to the browser that makes the request. It is very easy to create an ASP file. The scripts are directly added inside of the HTML file. `<%` and `%>` signs indicate that everything inside of these brackets are scripts and must be executed on the server before sending back to the browser. The result of these scripts usually generate some HTML code that is enriched by data.

The main advantage of ASP is that it puts all the burden of processing on the server. The script is executed and the resulting pure HTML code is sent back to the browser. There are five built-in objects in ASP:

- Server
- Session
- Request
- Response
- Form

By using these built-in objects, the programmer is saved from coding long lines of scripting codes, because these objects hold many useful functions inside. The following is an example of an ASP file. It is used to create a graphical control object.

```
1: <HEAD>
2: <TITLE> Marquee Control</TITLE>
3: </HEAD>
4: <SCRIPT LANGUAGE=VBScript>
5: <!--
```

```
Sub PageInit
```

```
End Sub
```

```
-->
```

```
</SCRIPT>
```

```
<BODY ONLOAD=PageInit>
```

```
<H1> The Object Tag </H1>
```

```
<P>
```

```
<OBJECT ID="Marquee1" WIDTH=500 HEIGHT=400 ALIGN=TOP BORDER=1  
CLASSID="CLSID:1A4DA620-6217-11CF-BE62-0080G72EDD2D">
```

```
<PARAM NAME="S2URL" VALUE="Circular">
```

```
<PARAM NAME="ScrollStyleX" VALUE="Circular">
```

```
<PARAM NAME="ScrollStyleY" VALUE="Circular">
```

```
<PARAM NAME="ScrollPixelsY" VALUE=90>
```

```
<PARAM NAME="ScrollStyleX" VALUE=0>
```

```
<PARAM NAME="DrawImmediately" VALUE=1>
```

```
<PARAM NAME="WidthOfPage" VALUE=500>
```

```
<PARAM NAME="ScrollDelay" VALUE=500>
```

```
</OBJECT>
```

```
</BODY>
```

```
</HTML>
```



## E. ACTIVEX DATABASE OBJECTS (ADO)

To reach data sources is one of the most important tasks that scripts must perform.

ADO is a component of ASP that can be used to get access to any ODBC compatible or OLE/DB Databases. By using ADO in ASP pages, programmers can add database access to their on-line documents. ADO is a combination of functions and variables that are grouped together to perform access operations on a database. Many of the programming languages like Java, Visual Basic, C++ or VBScript can be used to embed ADO components in ASP pages. There are three general purpose of objects in ADO:

- a. Command
- b. Connection
- c. Recordset

There are also some other objects for secondary tasks like field, property, parameter, and error.

The command object is used to define an SQL query to a database, the connection object is used to establish the required connection between the database and the application, and the recordset objects represent the result of the database query. The recordset object is the most important object of ADO since it can be used for everything necessary to retrieve data out of the database can be accomplished.

## F. COLD FUSION DATABASE APPLICATION

Cold Fusion is an application program created to ease the process of connecting a Web Site to a database.<sup>25</sup> Instead of writing scripts, simply adding special tags defined by Cold Fusion is enough to handle many operations, including database connectivity. These tags are inserted inside an ordinary HTML page, and convert that page to an interactive and dynamic document.

The main advantage of Cold Fusion is that a developer does not need to know any scripting language to be able to create effective database Web Applications. The tags that start with CF prefix are Cold Fusion Tags. The Cold Fusion Server handles these special tags.

The following is an example of an HTML Page supported by some Cold Fusion tags. This code fragment queries A2Z database and returns the last names of the employees (only the distinct ones)

```
<cfquery name="Report" datasource="A2Z">
    select distinct lastname
    from employees
</cfquery>
<html>
<head>
<title>last names </title>
</head>
```

---

<sup>25</sup>Allaire.com web site.

```
<body>
<h1>last names</h1>
<cfquery query="report" colheaders html table border>
<cfcol header="last name" text="#lastname#">
</cfquery>
</cftable>
</body></html>
```

In our application, we will use Cold Fusion as the middleware that provides the connection between the IPO database and the intranet system.

## V. THE NPS INTERNATIONAL PROGRAMS OFFICE (IPO)

IPO (International Programs Office) holds a critical mission: to integrate the international officers and their families into the life in the U.S.. In this chapter, we will examine the information infrastructure of the IPO and the ways to improve it.

### A. MISSION

1. IPO, The International Programs Office is responsible for the cultural, social and academic integration of the international community in the NPS.<sup>26</sup> The Office is charged with interacting with the outside agencies, military and civilian, to accomplish the goals of the Security Assistance Training Program (S.A.T.P) and the Information Program. Additionally, it is responsible for the International Sponsor Program and acts as the Command Sponsor to the International Committee.
2. IPO sponsors the courses IT1500 Information Programs Seminar for International Officers, which provides International students with an awareness and functional understanding of internationally recognized human rights and the American Democratic way of life, and IT 1600 Communication Skills for International Officers, which is designed to increase the student's ability and comprehension in communicating effectively in written and spoken English.
3. The International Committee (IC) is a non- profit organization with the purpose of promoting good relationships between the U.S. and the international students and their families, assisting with adaptation to American life and supporting international

---

<sup>26</sup> [web.nps.navy.mil / ~ ofcinst / frame.htm](http://web.nps.navy.mil/~ofcinst/frame.htm)

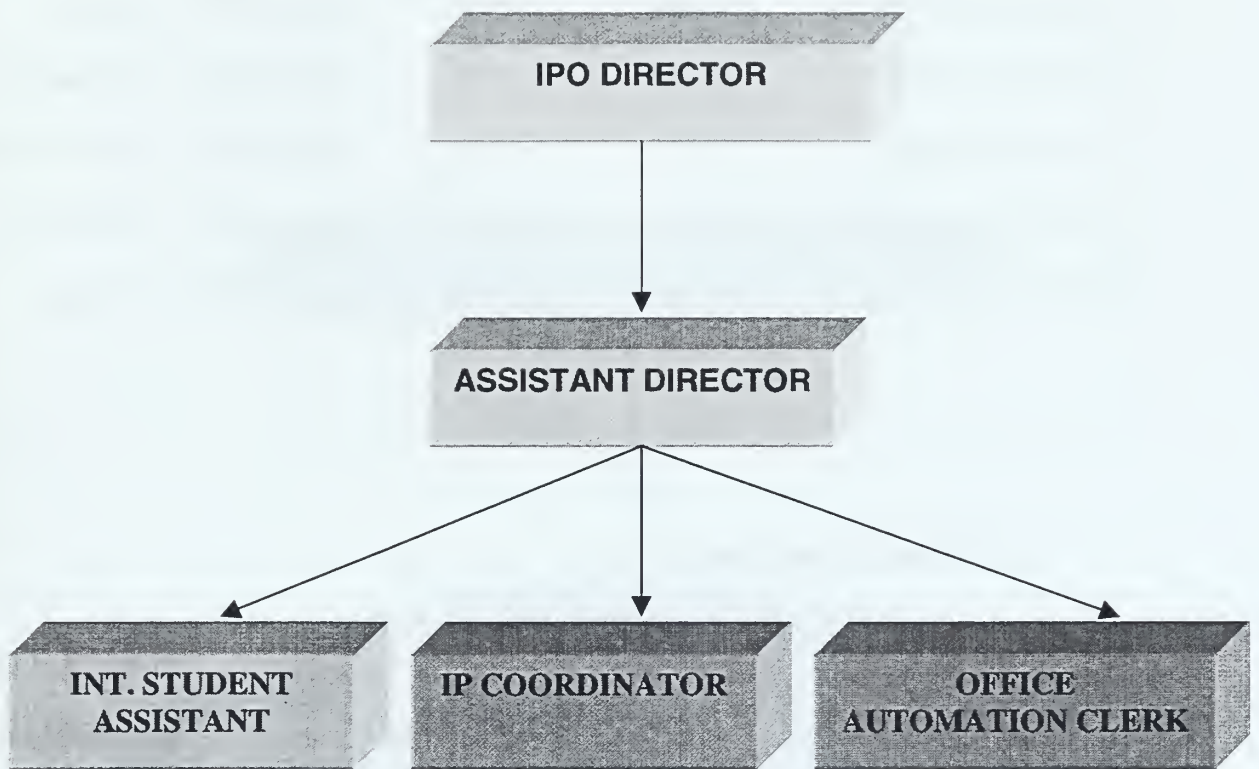
students and their families when needed and where possible. All international students attending the Naval PostGraduate School (NPS), their spouses and the sponsors of international students and their spouses are considered members of the IC.

## **B. ORGANIZATION**

The organizational structure of the NPS IPO is as follows:

1. **Director.** The director of the NPS IPO is responsible from the implementation of the policies stated by the SATP, Security Training Assistance Program. The Director also controls and coordinates the activities of the IPO.
2. **Assistant Director.** Assistant Director is the person who coordinates the personnel of the IPO and the daily activities of the IPO. He/she also acts as an advisor to the IC, International Committee.
3. **International Student Assistant.** This person is responsible from updating the IPO database. He/she keeps the records of the International Students and the people related to them (spouses, children, and sponsors).
4. **Information Program (IP) Coordinator.** IP Coordinator is responsible for planning the IP activities and keeping the records about these activities. He/she also prepares the required documents for the budget purposes.
5. **Office Automation Clerk.** He/she is responsible for preparing the daily official papers for the IPO, (Travel Orders, Invitation Letters, etc.)





**Figure 7: IPO organizational structure**

## **C. INFORMATION INFRASTRUCTURE**

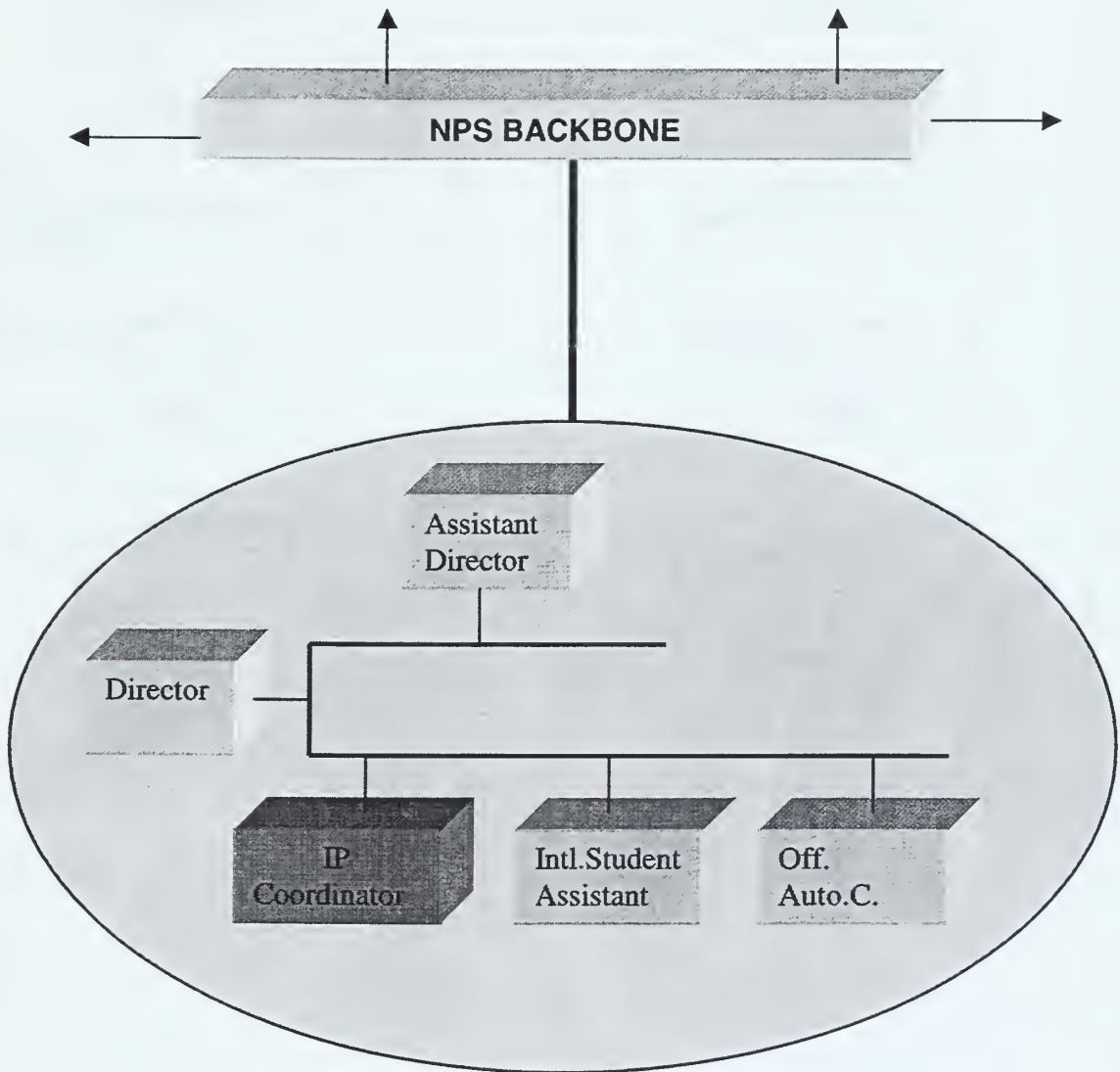
### **1. Hardware Components**

Currently, there are five personal computers in the IPO. The specifications of the computers are as follows;

<u>Microprocessor</u>	<u>Memory</u>	<u>Storage</u>	<u>OS</u>	<u>Operator</u>
Pentium II 266 Mhz	32 MB	3.1 GB	Windows95	Director
Pentium II 266 Mhz	32 MB	3.1 GB	Windows95	Assistant Dir.
Pentium II 266 Mhz	32 MB	3.1 GB	Windows95	Int. Stu. Assistant
Pentium II 266 Mhz	64 MB	3.1 GB	Windows95	Off. Auto. C.
Pentium II 266 Mhz	64 MB	3.1 GB	Windows95	IP Coord.

## 2. Network Components

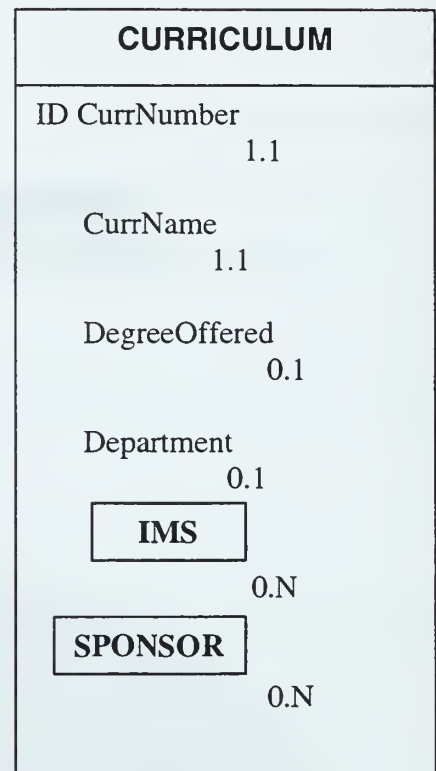
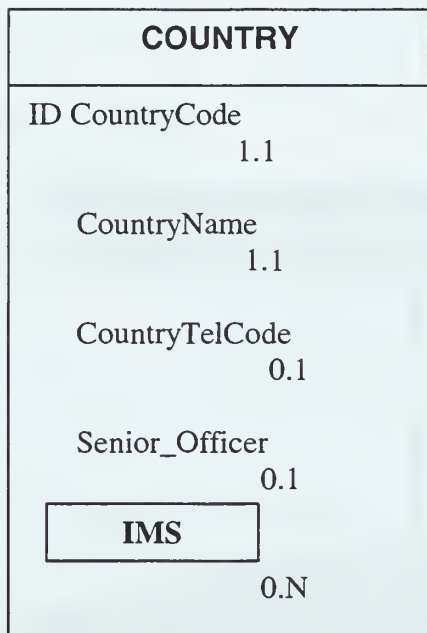
The computers in the IPO are networked (See Figure 8), but they are also used as stand-alone computers. Also, the LAN in the IPO is connected to the NPS Backbone. The data transfer rate between the NPS Backbone and the IPO LAN is 10 Mbps. The IPO LAN consists of CAT-5 wiring and five pieces of 10 Mbps NICs.

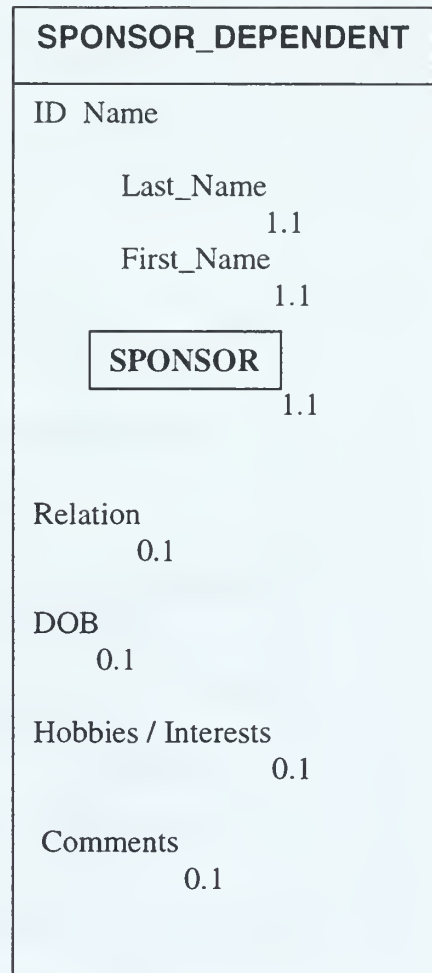
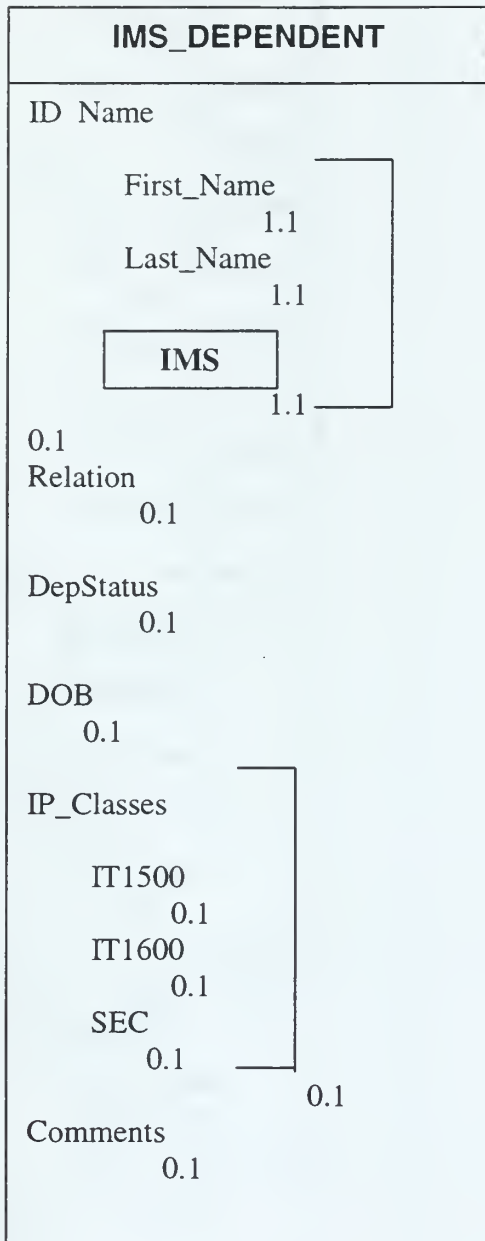


**Figure 8: IPO LAN**

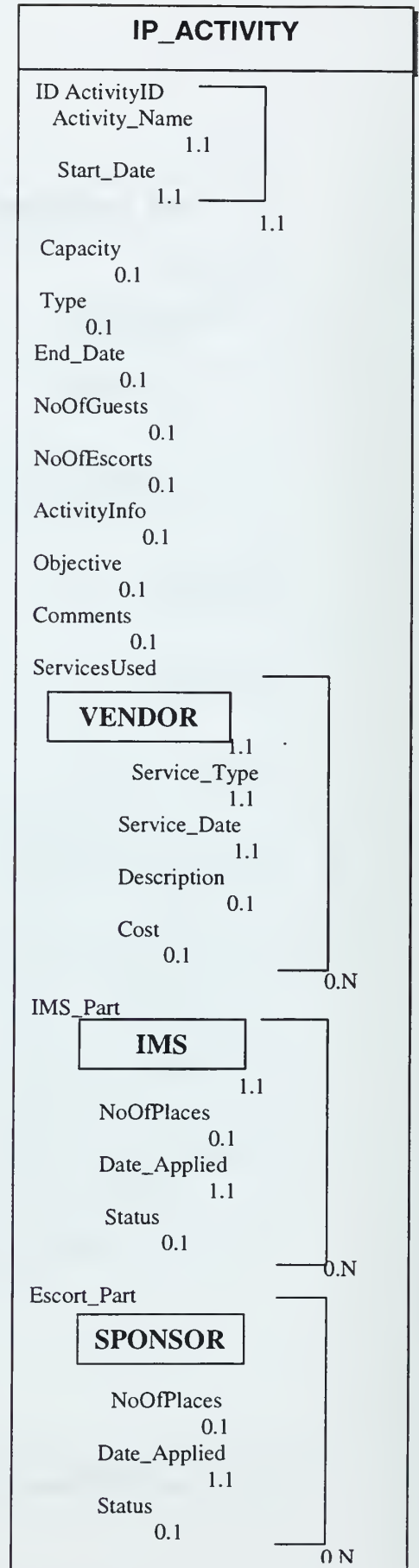
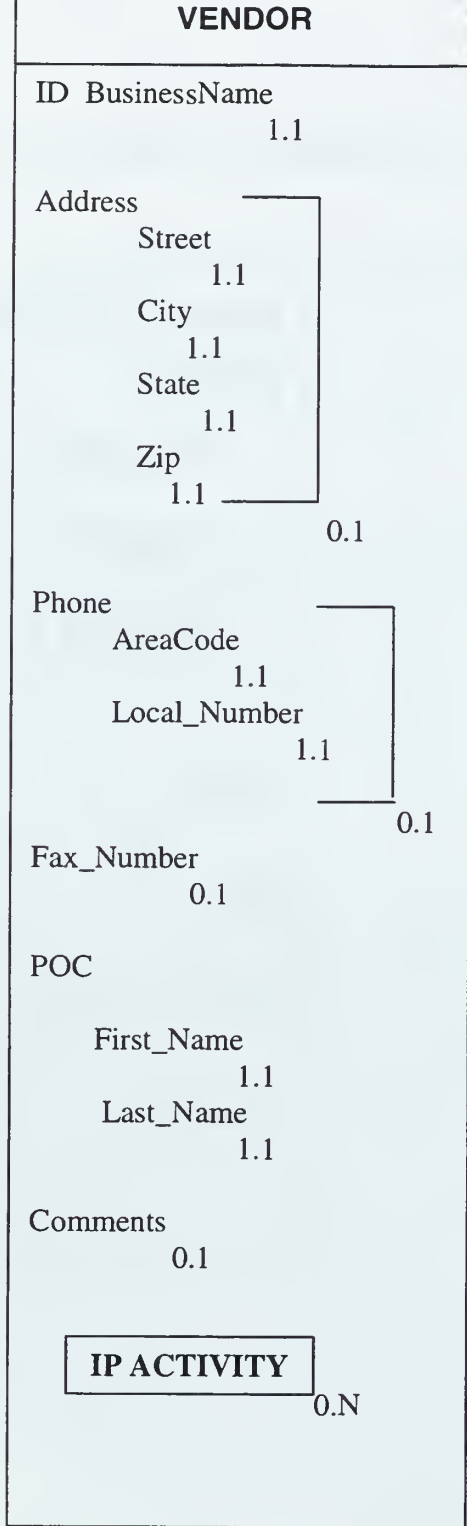
## D. DATA MODEL OF THE EXISTING DATABASE

The existing database has eight objects.<sup>27</sup> They are as follows:





<sup>27</sup> Celebi, Onder, NPS Thesis Study, P. 47.





# IMS

ID SCN 1.1

Name 1.1

    First\_Name 1.1

    Mid\_Name 0.1

    Last\_Name 1.1

Address 1.1

    Street 1.1

    City 1.1

    State 1.1

    Zip 1.1

    AddressStatus 1.1

    Authorization 1.1

Phone 0.1

    AreaCode 1.1

    Local\_Number 1.1

Housing 0.1

    Area 1.1

    Date\_IN 1.1

    Date\_OUT 0.1

Home\_Phone 0.1

    Area\_Code 1.1

    Local\_Number 1.1

Service 0.1

Rank 0.1

DOR 0.1

TuitionCode 0.1

DOB 0.1

ArrivalDate 0.1

Date\_Reported 0.1

Graduation 0.1

SGC 0.1

IP\_Classes 0.1

    IT1500 0.1

    IT1600 0.1

IP\_Penalty 0.1

    IP\_Status 0.1

    Date\_Penalized 0.1

Sex 0.1

Marital\_Status 0.1

DLI\_Attendance 0.1

WCN 0.1

Email 0.1

Comments 0.1

**SPONSOR**

0.N

**IMS\_DEPEN**

0.N

**COUNTRY**

1.1

**CURRICUL.**

0.1

**IP\_ACTIVITY**

0.N

## **E. EXISTING DATABASE MANAGEMENT SYSTEM (DBMS)**

Borland's Interbase Server, an SQL-compliant relational DBMS, is used as the DBMS of the IPO. Although it has features like SQL support, transactional management and multiple database access, we decided that MS Access is a more widely used system than Borland's Interbase and also compatible with IT21 standards.

## **F. REDESIGNED DATABASE**

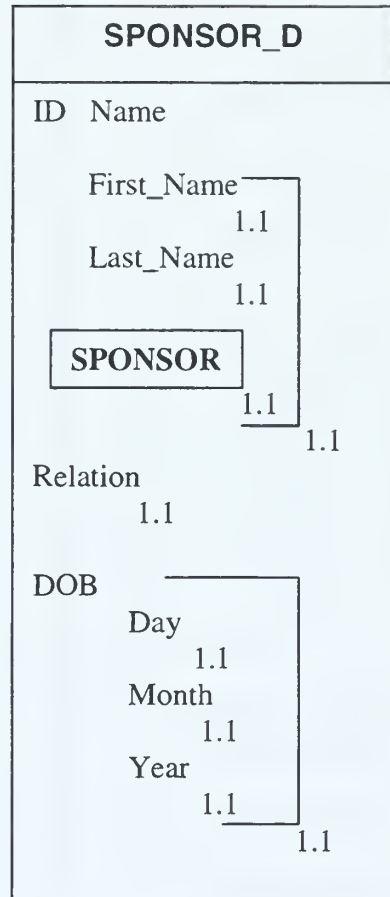
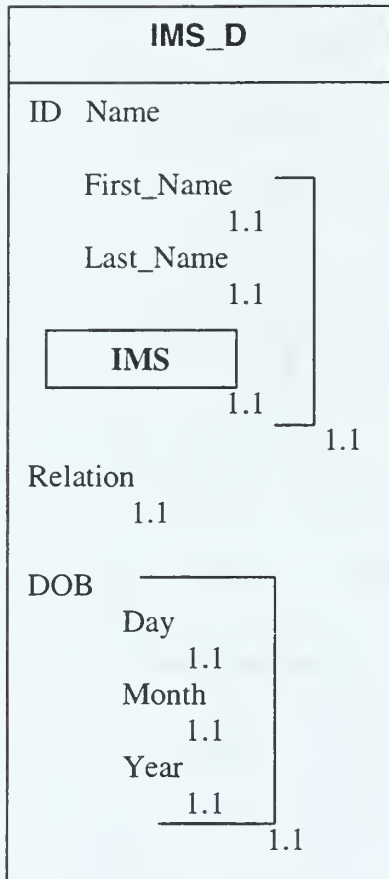
During our research, we found that some parts of the existing database are used very little, or not at all. These unused parts put a burden on the database operator in that the unused data must still be entered into the tables for the sake of the completeness.

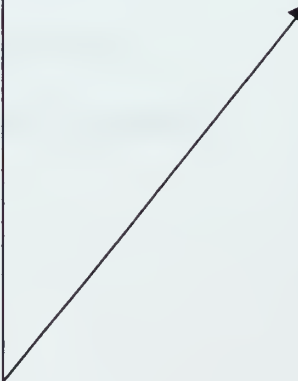
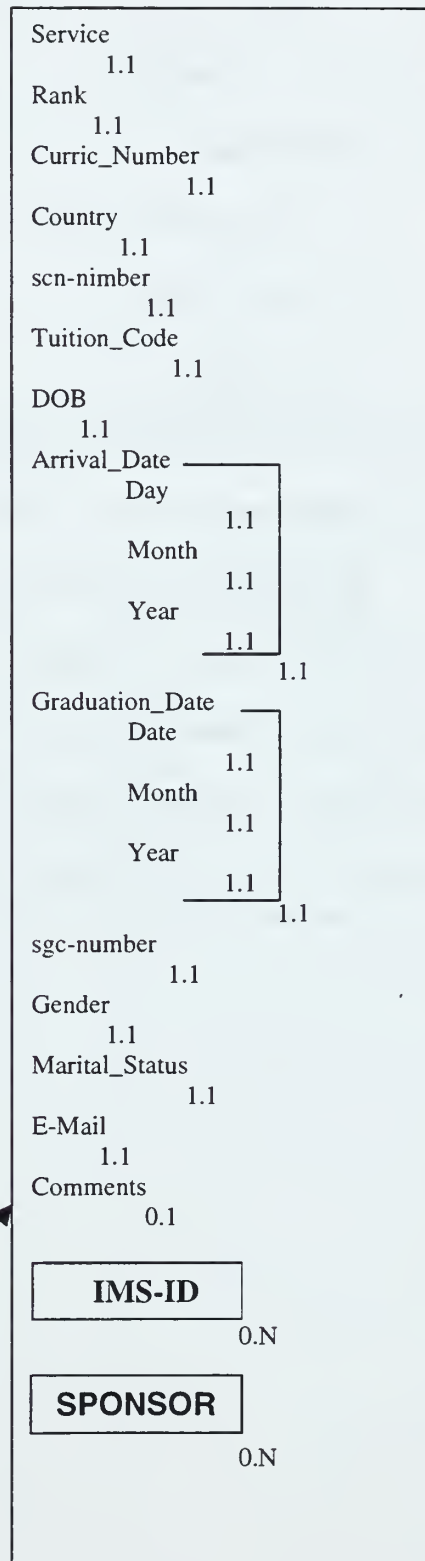
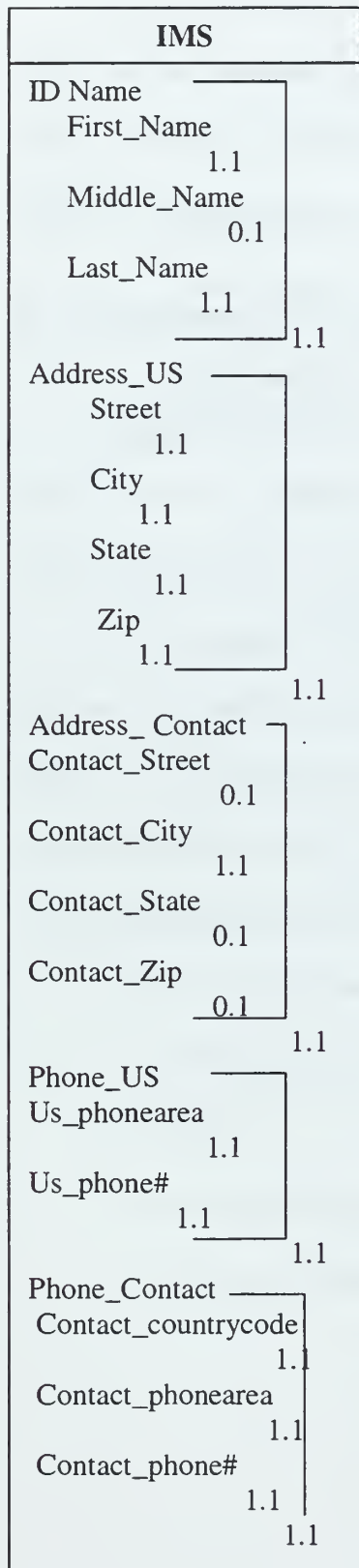
For example, the IP Activities table does not perform any role in the daily work of the IPO, because the IP Coordinator completes his job by making lists manually or preparing fliers for the chosen students. As a result, we concluded that some of the tables can be deleted completely, some of them can be merged, and some of the data can be exported to other tables before deleting the original table.

Our redesign includes four objects;

- IMS (International Military Student)
- Sponsor
- IMS-D(IMS Dependents)
- Sponsor-D (Sponsor Dependents)

The Object Model is as follows;





# SPONSOR

ID Name  
First\_Name 1.1  
Middle\_Name 0.1  
Last\_Name 1.1

Address 1.1  
Street 1.1  
City 1.1  
State 1.1  
Zip 1.1

Phone 1.1  
phoneare 1.1  
phone# 1.1

Service 1.1  
sgc-number 0.1  
ssn-number 1.1  
DOB 1.1  
Marital\_Status 1.1  
Date\_Assigned 1.1  
Gender 1.1  
Graduation\_Date 1.1  
Country 1.1  
Rank 0.1  
Curric-Number 0.1  
Comments 0.1  
E-mail 1.1

**IMS** 0.N

## G. THE FACTORS THAT AFFECT THE REDESIGN

- IP\_Activity object is deleted, because IP Coordinator completes his job by making lists manually or preparing fliers for the chosen IMS,
- Vendor object has never been used so it was deleted,
- The country and the curriculum object are merged with the IMS object,
- A contact address of the IMS was added to the IMS object ( to inform the relatives of the IMS in case of something important happens to her / him),
- A contact phone number was added for the reason mentioned above,
- IP\_Classes information is kept manually in lists so this information deleted,
- Some field names were changed. Example, Sex --> Gender,
- DLI\_Attendance and Hobbies/Interests fields are not needed so information so they are deleted,
- To make a search in the IPO database, the International Student Assistant mostly uses first name and the last name of Sponsor and IMS / Sponsor dependant. Country and Curriculum\_number are also sometimes used in conjunction with the first\_name and the last\_name,
- Country and Curriculum\_number are also sometimes used in conjunction with the first\_name and the last\_name for IMS searches,
- The IPO personnel mostly prefers reports that contains detailed information about the chosen IMS.



## VI. ANALYSIS AND DESIGN

### A. INTRODUCTION

The NPS IPO is a small organization. There are only five computers that are connected by a LAN. The choices for building an Intranet system are many, but for our specific case the limitations and the resources of the IPO forced us to eliminate some of them. After carefully considering the alternatives, we decided that Windows 95 OS is the best fit for our case.

A Web Server must be added to a LAN in order to convert it into an Intranet. Microsoft Personal Web Server (PWS) for Windows 95 OS is the best choice for our case. PWS is a freeware that comes with the NT extension package. All you need to do to obtain it is to register to Microsoft and download it. It does not have the complete set of features that the more powerful Web Server Internet Information Server (IIS) offers, but the features that come with it are good enough for a small organization or for personal use. Also it is easier to manage and install than IIS. This property was an important consideration in our choice, because we know IPO personnel, who are technologically unsophisticated, will have to maintain this system after we are gone.

After our interviews with the IPO staff and our studies on the subject, we decided to redesign the structure of the existing database and replace Borland's Interbase by Microsoft Access. Our main motive in this replacement is to be compatible with the new IT-21

standards.<sup>28</sup> Also, the Access database system is a much more widely used system than Borland's Interbase.

When it comes to selecting a way to make the connection between a database system and the Intranet or the extranet site, there are many available options. Of these alternatives, we chose the Allaire's Cold Fusion Application as the most suitable for our specific purposes. By using Cold Fusion, it is relatively easy to create real world solutions compared with CGI Applications and Server Side Scripts.

The final requirements for both hardware and software came after considering many choices. The justifications for our choices are given in next section.

## **B. PROCESS DECOMPOSITION MODEL AND DIAGRAM**

Figure 10 shows the decomposition diagram of the overhaul process.

**Level 0:** The first process is the Information System of the NPS IPO. It combines both the IPO DBMS and the IPO Intranet. It interacts both with internal entities like curriculum office and external entities like military attaches of the represented countries.

**Level 1:** There are three sub processes from the root process. These are Maintain IPO database, Administer IPO database and Create report and queries.

Maintain IPO database concentrates on collecting and keeping the data that are used in IPO database. Administer IPO database deals with the back up and security issues. Create report and queries are about the generation of reports and queries needed.

**Level 2:** In level two, Maintain IPO database has four sub processes, each of them dealing with maintaining a specific component like Sponsor, IMS, IMS\_D or Sponsor\_D.

---

<sup>28</sup> [web.nps.navy.mil / ~ library / it21.html](http://web.nps.navy.mil/~library/it21.html)

Administer IPO database process has two sub process, security maintenance and back-up procedures. Create Report and Queries has four sub processes. Each of these sub processes creates different reports and queries for different components.

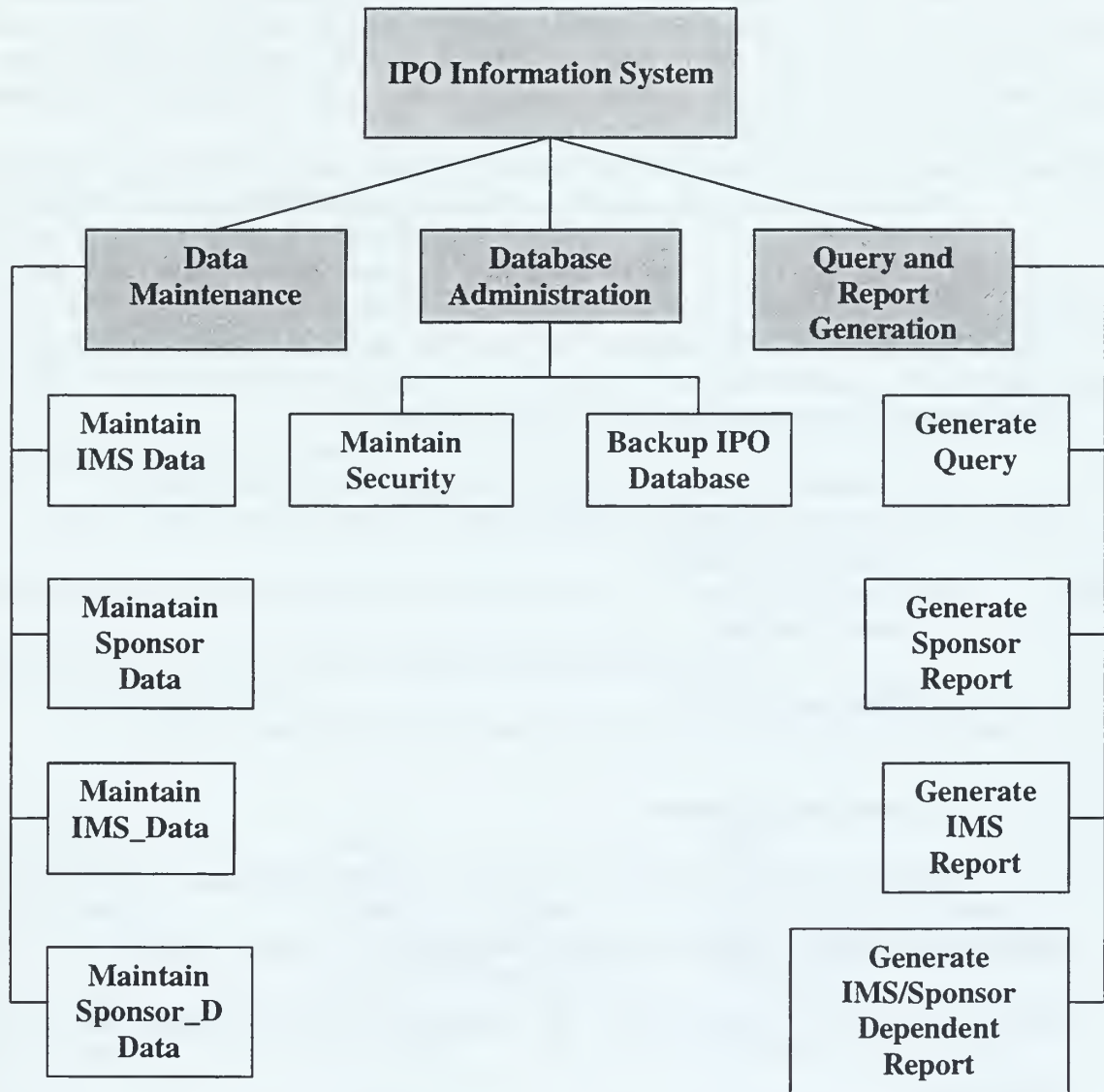


Figure 9: Decomposition Diagram

## C. NETWORK OPERATING SYSTEMS

Although there are several Network Operating Systems available, Windows 95 provides us the results we need. Windows 95 designed as a client – side OS, but it has a rich set of networking components that makes it really powerful for small-scale network environments. But our major motive to choose Win95 as the IPO NOS is that it is the existing OS that IPO already has been using.

The built-in networking support in Win95 is easy to setup and use. TCP/IP is bundled with the OS so there is no need to buy it as a separate product and it has a user interface, which is familiar to IPO personnel. On the other hand, it lacks the properties of a fully functional multi-user, multi-tasking OS like Windows NT.

Our candidates for the Network Operating System were as follows:

- Windows NT Server
- Novell Netware
- Windows 95 ( 98 )

### 1. Windows NT Server

Windows NT OS is a full scale Network Operating System. Its robust security and management features make it a real candidate for medium and large size network environments, but it also requires the knowledge and the management of a network administrator.

Windows NT Server is a genuine Network Operating System. Its services are especially optimized to give the best service for its clients. It also can be used as a client–

side OS but its relative, Windows NT Workstation, is better for this duty if the price and the services offered are compared.

Both Windows NT Server and Windows 95 share the same interface, but the underlying technology is almost completely different. Windows NT Server was designed from scratch to perform the roles of a real Network Operating System with features like preemptive multitasking, multiprocessing, multi platform support, secure file systems and fault tolerance. The programs that will be used on Windows NT Server must be specially written for it or compatible to work on it.

A Windows NT Server machine can play many roles in a network. For example it can be a file server, a database server, or a web server for an intranet side. It performs all of these duties with great success.

Both Intel microprocessors and the RISC (Reduced Instruction Set Chips) microprocessors can be used in NT Servers. NT supports three kinds of RISC microprocessors. These are MIPS, Digital Alpha, and PowerPC.<sup>29</sup>

The minimum Hardware Requirements for Windows NT Server are as follows:

<u>Component</u>	<u>Intel</u>	<u>RISC</u>
Microprocessor	80486/25 or higher; Any Pentium will provide Acceptable performance	MIPS, Digital, or PowerPC Alpha will provide acceptable performance
Disk Storage	120 MB	150 MB
Memory	16 MB	16 MB
Display	VGA or higher resolution Video display adapter.	VGA or higher resolution Video display adaptor



Required drive	Additional CD-ROM or access to files from a networked CD-ROM	SCSI CD-ROM drive or access to files from a networked CD-ROM
----------------	--	--

## **2. Novell NetWare**

Novel NetWare 3.x and 4.x are the most widely installed Network Operating Systems in the world. Despite their wide acceptance, in the recent years they have started to lose market share against the Windows NT Server.

Novel NetWare 4 x is specially designed for organizations that need a cost-effective and reliable network OS. In the file server role, it is accepted as the fastest server available for medium to large enterprises, but it only runs programs written for NetWare.

The minimum hardware requirements for the Novel NetWare are as follows:

- 386 Based PC or above
- 16 MB RAM
- At least 55 MB of Free Hard Disk Space

## **3. Windows 95**

Windows 95 is not designed to perform a server role but its rich network feature set makes it very suitable for small-scale network environments; it also enables the use of 32-bit applications.

---

<sup>29</sup> Strobe, Matthew, MCSE NT Server 4 Study Guide, P. 73.



A real network OS puts many burdens on the shoulders of the network administrator, but it is relatively very easy to create and manage small network environments by using Windows 95.

Unfortunately however, features like overhauling system security, multi-user environment support, and secured file system structures are weaker compared to the other candidates that were mentioned above.

The minimum requirements for Windows 95 are as follows:

**Computer/ Processor** 486/25 MHz-based system

**Memory** 8 MB of memory (RAM)

**Hard Disk** 40-45 MB of available hard disk space

**Display** VGA or higher-resolution display

**Upgrade** requires Windows 3.x or Windows for Workgroups 3.x

**Peripheral/ Miscellaneous** Microsoft Mouse or compatible pointing device

#### **D. DATABASE SYSTEM**

We considered MS SQL Server and MS Access as our candidates for this project, but after deciding upon Windows 95 as the OS for the IPO Intranet, MS SQL Server was no longer an option since it requires Windows NT Server as the OS.

Although MS SQL Server is a more robust, for a small network like IPO Intranet we concluded that MS Access will be sufficient to meet the moderate demands of the IPO staff. The other main reason for choosing MS Access is its relative ease of management and design philosophy. MS Access offers a functional relational database system. This means that the tables that are created can be joined in similar attributes. For our relatively small application,

we concluded that there is no need for a complicated and powerful client-server type database system, so we chose MS Access as the database system of the IPO Intranet. The requirements to use MS Access are as follow:

- CD-ROM drive.
- Display VGA or higher-resolution video adapter (Super VGA, 256-color recommended).
- Computer/Processor Personal or Multimedia computer with a 486 or higher processor.
- Memory on Windows 95 12 MB of memory required.
- Microsoft Windows 95 operating system.
- 9600 or higher-baud modem (14,400 baud recommended).
- Hard Disk with 28-60 MB of -available hard-disk space required.
- 40 MB required for typical installation, depending on configuration.

## **E. WEB SERVER SOFTWARE**

Microsoft Personal Web Server (PWS) for Windows 95 is a free and low maintenance solution for light – traffic intranet sites like IPO. PWS offers HTTP and FTP services. It supports ISAPI extensions and CGI, but it does not support Java. It has a four – tier security model.

The main reasons for us to choose the PWS are its price (free) and ease of use. Although it performs many roles that can be accepted from a fully functional web server software, it is relatively much easier to install and manage. PWS is especially ideal for small-size network environments.

The minimum requirements for the PWS are as follows:

- Pentium 33 MHz or higher; Pentium 90 MHz recommended
- 16 MB of memory (RAM); 20-32 MB recommended
- 40 MB of available hard-disk
- VGA; Super VGA recommended Microsoft Mouse or compatible pointing device

## **F. THE APPLICATION SOFTWARE FOR THE DATABASE AND INTRANET CONNECTIVITY**

We have examined many of the possible solutions to provide the connectivity between the database and the IPO Intranet like Active Server Pages (ASP), CGI, Server Side Scripts and build-in features of the MS Access. We concluded that although using ASP with MS interDev platform can create powerful and robust solutions, the learning curve to establish a well – designed product is pretty steep. Also, CGI and Server Side Script give the developer many features and capabilities, but it is very demanding to create real world applications by using these concepts.

Allaire's Cold Fusion Web Construction Kit is an easy to use software product that enables the developer to create a working product in a short time. The learning curve is very fast, if the developer has a background on writing HTML code. The Cold Fusion Markup Language is similar to HTML; Cold Fusion (CF) Tags are simply placed inside the HTML code, and the remaining job is done by the Cold Fusion Server that is on the same machine with the Web Server.

The minimum requirements for the Cold Fusion are as follows:

- Pentium 100 Microprocessor

- 32 MB RAM
- 200 MB Storage Space

The working mechanism of the Cold Fusion is very similar to a classical client - server type application. We can explain this better by an example. Consider a database system that can be searchable via Internet. When a user makes a request for something specific by typing some keywords for the database search, the following steps occur:

1. The file with the .cfm extension, which is responsible for the operation of finding the corresponding results is first checked by the Cold Fusion Server.
2. If the .cfm file contains Cold Fusion tags, everything between these tags is processed by the server.
3. The results of these tags are sent to the Web Server and relayed to the client (user that makes the request) as an HTML file that can be seen by the user's browser software.
4. The Cold Fusion Server creates a layer of abstraction for the user by processing the CF tags before the Web Server; see Figure 11.

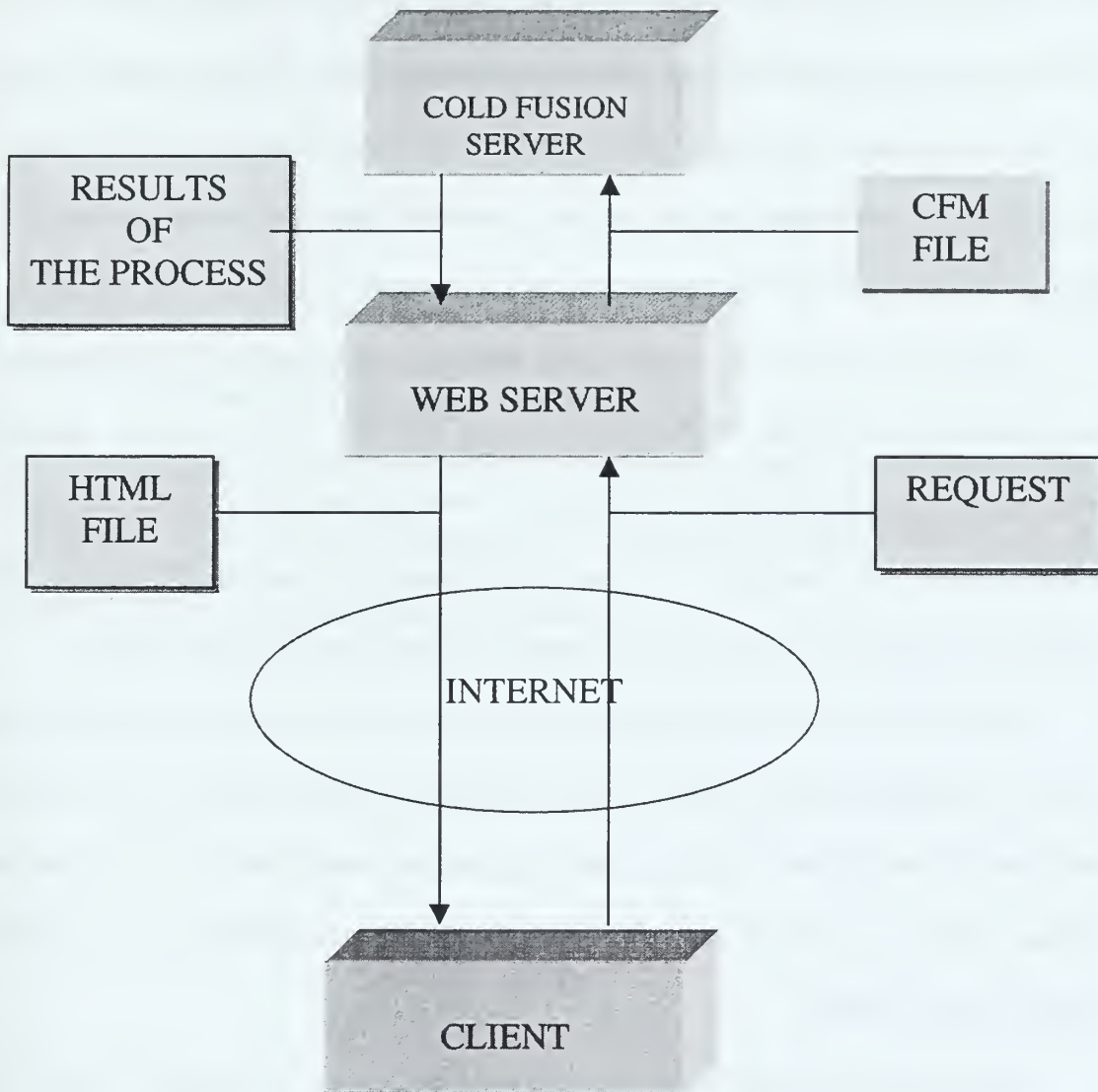
## **G. PROTOTYPE DESIGN**

### **1. Database**

As we mentioned above, Microsoft Access 97 has been chosen for IPO database system. The database consists of four tables; IMS, IMS Dependent, IMS Sponsor, and IMS Sponsor Dependent. To link all of these four tables, we designated those student and sponsor first and last names as primary keys.

The attributes for all of these tables as described in Appendix A: are taken from the database forms, and they are the same as the attributes for data entry forms in the IPO

intranet. In this case, the data entered by users will be stored directly in the database system, and it will be easy for the person who is in charge to manage and control it.



**Figure 10: Mechanism of Cold Fusion**



## **2. IPO Intranet**

The IPO intranet solution facilitates the modification of IMS database for authorized users, and information retrieval only for other users. Several web pages are designed for users to interact with the application and the database on the IPO intranet. These web pages are built in a hierarchy to facilitate easy navigation for users with the Cold Fusion software application. All web pages can be seen in Appendix C including the source codes of this thesis.

The main page of the IPO intranet is a front page containing four menus labeled Data Entry, Search and Detail, Update, and Delete Records. For security reasons, an authentication and password are required before users can retrieve or modify data from the database system. This safeguard is needed for the situation where the IPO intranet will be published in NPS intranet in which case unauthorized users can violate the system.

In Data Entry, there are four choices that can be used to add data to database system. To have a complete database system with all information about students and their sponsors, users must fill out all four choices. These data will be stored directly into MS Access 97 database systems. Access to this menu can be restricted to authorized users to protect the database system contents.

The Search and Detail Data menu provides users with four choices to retrieve data from the database system. Users are allowed to search student, student dependent, sponsor, and sponsor dependent data. It can be specified for unauthorized users.

The four choices in the Update menu are provided to update the corresponding chosen database object. It uses primary keys to search and find the requested record and fill



out a form which looks like a data entry form with the data of the chosen record. After the changes are done, the form is sent for the changes to take effect.

The Delete menu should be used with care because there is no restore option available after a delete operation is performed. Authorized users can delete records from any of the four objects in the database.

Since the database tables and intranet are an integrated system, it is highly recommended that Delete, Update, and Data Entry menus be used by authorized users only.

### **3. System Guide**

A system guide has been created to help users understand the basic concepts of the system and how to use it (Appendix B). A non-technical description is used to be more helpful to non-computer literate end users.



## VII. CONCLUSION

The NPS IPO has to deal with many issues related to the international community, which is a part of the NPS. The task is challenging and requires the coordination and help of computer technology to address.

The existing information structure of the IPO is not adequate to handle the task. The LAN is not used effectively and the database system is far from being easy to use and maintain.

In our solution we suggest an upgrade of the existing LAN with an intranet by using the same infrastructure and adding a web server as the central point of the system.

Also, we suggest modification of the existing Borland database system with a Microsoft Product (MS Access). Although, MS Access is not a client – server, heavy-duty database system, the features it has are sufficient for a small application like IPO. Also, it is much more well known than Borland's database system.

After our research, we concluded that a structural redesign of the database can also be helpful for the performance and maintenance of the system. In our solution we used four tables to construct the database. We noticed that some of the tables of the existing database are included in the design level for the sake of the completeness, but in reality are not used by the IPO. These should therefore be eliminated.

In our opinion, the biggest benefit of the IPO will come from the usage of the Internet browser as an interface to the underlying database. The operator of the database system need not know any technical details about the information system (e.g. SQL statements or the

meaning of the database management system icons) to perform her daily activities. All she needs to know will be the browser software, which is already familiar to her.

Another main advantage of our proposed solution is the Intranet system will enable wider availability to other IPO personnel who currently cannot access the database system. The intranet will provide an easy way for them to reach the database to collect data necessary for the tasks of the office personnel. They can also use the browser to access the database and make queries without interfering with the database operator.

## APPENDIX A. PROPERTIES OF THE DATABASE FIELDS

### Address-US

Type : Group

Minimum : 1

Maximum : 1

Field Type : Text

Length : 25-15-5-10 (Street - City - State - Zip)

Default : -

Description : The address of the IMS in the US

### Address-Contact

Type : Group

Minimum : 1

Maximum : 1

Field Type : Text

Length : 25-15-5-10 (Street - City - State - Zip)

Default : -

Description : The address of the IMS in his/her own country

### Arrival-Date

Type : Group

Minimum : 1

**Maximum** : 1  
**Field Type** : Date/Time  
**Length** : dd/mm/yy  
**Default** : -  
**Description** : The day that the IMS arrived to the US

**Comments**

**Type** : Simple  
**Minimum** : 0  
**Maximum** : 1  
**Field Type** : Text  
**Length** : 100  
**Default** : -  
**Description** : Any additional information/warning

**Country**

**Type** : Simple  
**Minimum** : 1  
**Maximum** : 1  
**Field Type** : Text  
**Length** : 25  
**Default** : -



**Description** : The country of the IMS (IMS Table) / The country of the sponsor  
(Sponsor Table)

**Curric-Number**

**Type** : Simple

**Minimum** : 1

**Maximum** : 1

**Field Type** : Number ( Long Integer )

**Length** : 3

**Default** : -

**Description** : The number of the IMS's curriculum (IMS Table) / The number of the  
Sponsor's Curriculum (Sponsor Table)

**Date-Assigned**

**Type** : Simple

**Minimum** : 1

**Maximum** : 1

**Field Type** : Date/Time

**Length** : dd/mm/yy

**Default** : -

**Description** : The date of the sponsor's assignment as the IMS Sponsor

### DOB

**Type** : Simple  
**Minimum** : 1  
**Maximum** : 1  
**Field Type** : Date/Time  
**Length** : dd/mm/yy  
**Default** : -  
**Description** : The date of birth (for all the tables)

### E-mail

**Type** : Simple  
**Minimum** : 1  
**Maximum** : 1  
**Field Type** : Text  
**Length** : 25  
**Default** : -  
**Description** : The e-mail address (both for the sponsor and the IMS)

### Gender

**Type** : Simple  
**Minimum** : 1  
**Maximum** : 1

**Field Type** : Yes/No

**Length** : -

**Default** : Male

**Description** : The Gender Info (Both for the sponsor and the IMS)

### Graduation-Date

**Type** : Simple

**Minimum** : 1

**Maximum** : 1

**Field Type** : Date/Time

**Length** : dd/mm/yy

**Default** : -

**Description** : The date of graduation from the NPS (Both for the sponsor and the IMS Tables)

### Marital-Status

**Type** : Simple

**Minimum** : 1

**Maximum** : 1

**Field Type** : Yes/No

**Length** : -

**Default** : Single

**Description** : Marital Info (Both for the IMS and the Sponsor Tables)

**Name**

**Type : Group**

**Minimum : 1**

**Maximum : 1**

**Field Type : Text**

**Length : 25 - 25 - 25**

**Default : -**

**Description : The names of the beholder (First - Middle - Last) for all of the Tables**

**Phone**

**Type : Group**

**Minimum : 1**

**Maximum : 1**

**Field Type : Text**

**Length : 5-20 (area # - phone #)**

**Default : -**

**Description : The phone number of the IMS's sponsor**

**Phone-Contact**

**Type : Group**

**Minimum : 1**

**Maximum : 1**

**Field Type** : Text  
**Length** : 5-5-20 (country # -area # - phone #)  
**Default** : -  
**Description** : The IMS's telephone number at his/her country

**Phone-US**

**Type** : Group  
**Minimum** : 1  
**Maximum** : 1  
**Field Type** : Text  
**Length** : 5-20 (area# - phone#)  
**Default** : -  
**Description** : The IMS's telephone number in the US

**Rank**

**Type** : Simple  
**Minimum** : 0  
**Maximum** : 1  
**Field Type** : Text  
**Length** : 20  
**Default** : -  
**Description** : The rank of the IMS / Sponsor (if not civilian)

### Relation

**Type** : Simple

**Minimum** : 1

**Maximum** : 1

**Field Type** : Text

**Length** : 20

**Default** : -

**Description** : The relationship of the dependent (both for the sponsor\_dependent and The IMS\_dependent tables)

### Service

**Type** : Simple

**Minimum** : 0

**Maximum** : 1

**Field Type** : Text

**Length** : 20

**Default** : -

**Description** : The service Info (Navy, Civilian, etc.), both for the IMS and the Sponsor

### SGC

**Type** : Simple

**Minimum** : 1



**Maximum : 1**

**Field Type : Text**

**Length : 10**

**Default : -**

**Description : The number of the mailbox at the school (For sponsor and the IMS tables)**

### **SCN**

**Type : Simple**

**Minimum : 1**

**Maximum : 1**

**Field Type : Text**

**Length : 20**

**Default : -**

**Description : The unique number that is given to the IMS**

### **SSN**

**Type : Simple**

**Minimum : 1**

**Maximum : 1**

**Field Type : Text**

**Length : 20**

**Default** : -

**Description** : The Social Security Number

**Tuition-Code**

**Type** : Simple

**Minimum** : 1

**Maximum** : 1

**Field Type** : Text

**Length** : 10

**Default** : -

**Description** : The type of the IMS's tuition

## **APPENDIX B. SYSTEM GUIDE**

### **I. INTRODUCTION**

The IPO Information System is a combination of a DBMS and an intranet. With the enhanced features of this information system, the dissemination of the required data for the operations of IPO will be more efficient.

This guide can be used to install the required components of the system. Also there is sufficient information to configure and use the system. The chapters, which provide the details are as follow;

- Chapter 2: Contains detailed information about the software, hardware, and documentation requirements to run the IPO Information System Properly.
- Chapter 3: Includes information about the installation process of the components.
- Chapter 4: Includes information about how to use the system.
- Chapter 5: Contains information about how to handle the security issues specific to this application.
- Chapter 6: Includes information about the database backup and recovery issues.

### **II. SYSTEM REQUIREMENTS**

#### **A. SOFTWARE REQUIREMENTS**

- Cold Fusion Server Software ( version 3.0 )
- Microsoft (MS) Windows 95 OS as the NOS

- Source Code which was added as the appendix c
- Web Browser Software ( preferably MS Internet Explorer 4.01 )
- Web Server Software ( MS Personal Web Server )
- MS Access 97 Database System

## **B. HARDWARE REQUIREMENTS**

### **1. Server Side**

- Minimum Intel Pentium 100 Microprocessor
- Minimum 32 MB RAM
- Min 300 MB Storage Place

### **2. Client Side**

- Intel Pentium 90 or Higher Microprocessor
- 16 MB RAM
- 20 MB Storage Place

## **C. DOCUMENTATION**

- Data Model
- Source Code
- Decomposition Model
- Field Properties
- System Guide

### III. INSTALLATION

In this chapter we will discuss the installation process of the system's components.

#### A. MS PERSONAL WEB SERVER

This software component can be obtained from Microsoft's web site at [www.microsoft.com](http://www.microsoft.com). It comes as an option pack for Windows NT but there is also a version that can be used for Windows 95. The download wizard takes care most of the installation process. The steps to install the component are as follow;

- Download the download.exe file into your hard disk
- Click this file to start the installation process
- Answer the questions as follow:
  1. The license agreement ---> Yes, I agree.
  2. Download options ----> Install.
  3. Option Pack ----> Typical Installation.
  4. Path to the folder ---> Browse until you reach to the place that you want to save the PWS files.
  5. Wizard will show you the download sites ----> Choose the physically nearest location.
  6. Microsoft active setup window will appear and the download of the PWS begin. The total size of the files is 24 MB.
  7. After the download completed, the setup wizard will appear.
  8. The license agreement ----> Yes, I agree.

9. Choose your web publishing home directory -----> c:\inetpub\wwwroot.
10. The setup wizard will install the rest of the files and complete the installation.

## **B. COLD FUSION SERVER**

- Run the CF31PRO.exe file by clicking it, this will start the installation process
- License agreement ----> Yes, I agree
- Installation directory ---> Browse to the directory that you want to install the Cold Fusion Server, we recommend to choose c:/cfusion
- Select components ----> Choose Cold Fusion Program Files, Documentation and Examples, CFXAPI Tag Development Kit
- Select Web Server -----> Choose Personal Web Server
- Select Web Server Document Directory -----> Cold Fusion will automatically detect the location of the web server, if it fails you can browse to help it.
- Select Administrator Password -----> Choose a password and confirm it. Before choosing a password, check out the rules in chapter four of this appendix
- Select Cold Fusion Studio Password ----> Choose and confirm a password. We recommend you to use the same password you chose for the administrator purposes
- To test the cold fusion, select the welcome to cold fusion option from the cold fusion group from the program menus. Select the installation test option.



## IV. SECURITY

### A. INTRODUCTION

IPO intranet is a self-contained network and not connected to the Internet (Although it can easily be converted into an extranet in the future). The most important security issues for IPO Information System are authentication, access and file/ directory rights.

In this chapter, we tried to point out some important issues in providing a reasonable security policy for the IPO.

### B. THREATS

There are two types of threats that may create problems for a network;

- Internal threats
- External threats

#### 1. Internal Threats

For our case, there is no reason to be suspicious about the employees of the IPO regarding a security breach or compromise. But in general, a network manager can never know what an employee / user can do to the network if he / she suddenly becomes angry with his / her superior. Constant monitoring is the best security measure for internal threats, although auditing may also be helpful. (Auditing features are pretty strong in Windows NT but for our application we use Windows 95 which lacks these features)

## 2. External Threats

External threats can be grouped as follows:

- External threats through the network
- External threats through physical means

Because IPO intranet is not connected to the Internet, we do not need to consider the first type of threat, but in general, the most common way of fighting such threats is putting a firewall between your network and the Internet.

A network administrator must think carefully about the security problems before connecting his / her local network to the Internet. The Internet should be considered as a hostile environment.

There may be three types of physical threat to the IPO information system:

### a. Threats to hardware

- The computers and printers may be stolen. But this is a very small threat considered that IPO office is located in the middle of a military installation and the only way in and out of the school is controlled by the military police.
- Sabotage by an employee. This is not a case for the IPO personnel.
- Destruction by fire, electrical surges or earthquake. For these catastrophes, there is little IPO personnel can do. But if they follow the regulations that are used for the whole school, the danger of a fire or electrical surges may be reduced.

### **b. Threats to software / information:**

We do not expect any of the employees to harm the software either by accident or malicious intent. So, the only threat to software and information may come from the visitors to the office. To prevent this, the personnel must lock their rooms when they leave for a long time. And the computer in the first room of the office must be controlled carefully because most of the time there are many people doing something there.

### **c. Security goals of the IPO**

We can formulate the security goals of the IPO as follow:

- Protecting the integrity and confidentiality of the IPO database,
- Preventing accidental damage to the system,
- Preventing unauthorized access to the system.

## **C. PASSWORD**

Passwords are essential elements for the security of an intranet system and they are also easy to implement. Currently IPO personnel are using passwords for protecting their personnel computers against unauthorized access. But there are a few points that may be remembered when choosing a password:

- Passwords should always be a mixture of numbers, lower and upper case letters
- Passwords should be minimum of 6 characters
- English words, names, TV and cartoon characters, cities and a sequence of letters should not be used ( Ex : qwerty )

- Passwords must be changed every three months.

#### **D. SECURITY OF THE INTERNET SERVER**

Because the IPO intranet server will not be connected to the Internet, we may concentrate on the physical safety and security of the server. The server will reside on the International Student Assistant (ISA)'s computer, which is in the back room and not exposed to the heavy traffic of visitors. The ISA must be careful about the physical security of the server and lock her door whenever she leaves the room.

#### **V. DATABASE BACKUP AND RECOVERY**

A backup process is a very essential part of an information system. For the NPS IPO database, we recommend tape backup. Tape backup is the minimum level of fault tolerance that should exist for all database systems. Tape backup preserves all the data on a database in case something bad happens. Data can be recovered from the tapes after the trouble settled.

There are two common methods for backups. These are full system backups and incremental backups. In the full system backup, all the data in the database are copied to the tapes on a daily basis. To be able to achieve full system backups, the tapes that will be used must be higher in capacity than the database, which will be copied.

The other method is incremental backup. We do not recommend this method for the IPO database, because IPO database is small enough to enable a full system backup on a daily basis.

To be able to achieve a local tape backup, a tape drive must be placed to the computer of the International Students Assistant (ISA). Also sufficient amount of tapes must be obtained. We recommend daily full database backups but if the load of work does not allow this, weekly full system backups may be done. If something happens to the database system, only the last week's work will disappear. The database system can be recovered by using the system backup tapes.

Another important point is that at least one of the backup tapes of the system must be preserved in a different physical location than the ISA's office. If something damages the office, the backup tapes may also be demolished, so it is a wise idea to keep one set of the system backup tapes at home.





## APPENDIX C. APPLICATION CODES



## Data Entry Form For IMS Table

First Name	<input type="text"/>	Tuition Code	<input type="text" value="FMS"/>
Middle Name	<input type="text"/>	US Area Code	<input type="text" value="831"/>
Last Name	<input type="text"/>	US Phone Number	<input type="text"/>
Country	<input type="text" value="Turkey"/>	US Street	<input type="text"/>
Service	<input type="text" value="Navy"/>	US City	<input type="text" value="Monterey"/>
Rank	<input type="text" value="1LT"/>	US State	<input type="text" value="CA"/>
Gender	<input type="text" value="Male"/>	US Zip Code	<input type="text" value="93940"/>
Marital Status	<input type="text" value="Single"/>	Contact Country Code	<input type="text" value="90"/>
DOB	<input type="text"/>	Contact Area Code	<input type="text"/>
Curriculum #	<input type="text" value="370"/>	Contact Phone Number	<input type="text"/>
Graduation Date	<input type="text" value="/99"/>	Contact Street	<input type="text"/>
Email	<input type="text" value="@nps.navy.mil"/>	Contact City	<input type="text" value="Istanbul"/>
SGC #	<input type="text"/>	Contact State	<input type="text"/>
SCN #	<input type="text" value="TK"/>	Arrival Date	<input type="text"/>
		Comments	<input type="text"/>

```

<HTML>
<HEAD><TITLE>Data Entry Form For IMS Table</TITLE></HEAD>
<BODY bgcolor="#000173" text="#FDD708" LINK="#FDD708"
vlink="#FDD708">
<basefont face="arial, helvetica">
<center>
<table>
<tr>
<td></td>
<td><H2>Data Entry Form For IMS Table</H2></td>
</tr>
</table>
</center>
<hr noshade>
<FORM ACTION="DataEntryIMS.CFM" METHOD="POST">
<INPUT TYPE="hidden" NAME="ims_first_name_required" VALUE="You cannot
leave the field (First Name) empty.">
<INPUT TYPE="hidden" NAME="ims_last_name_required" VALUE="You cannot
leave the field (Last Name) empty.">
<INPUT TYPE="hidden" NAME="country_required" VALUE="You cannot leave
the field (Country) empty.">
<INPUT TYPE="hidden" NAME="service_required" VALUE="You cannot leave the
field (service) empty.">
<INPUT TYPE="hidden" NAME="gender_required" VALUE="You cannot leave the
field (Gender) empty.">
<INPUT TYPE="hidden" NAME="marital_status_required" VALUE="You cannot
leave the field (Marital Status) empty.">
<INPUT TYPE="hidden" NAME="date_of_birth_required" VALUE="You cannot
leave the field (DOB) empty.">
<INPUT TYPE="hidden" NAME="curriculum_number_required" VALUE="You
cannot leave the field (Curriculum #) empty.">
<INPUT TYPE="hidden" NAME="graduation_date_required" VALUE="You cannot
leave the field (Graduation Date) empty.">
<INPUT TYPE="hidden" NAME="email_required" VALUE="You cannot leave the
field (Email) empty.">
<INPUT TYPE="hidden" NAME="sgc_number_required" VALUE="You cannot
leave the field (SGC #) empty.">
<INPUT TYPE="hidden" NAME="scn_number_required" VALUE="You cannot
leave the field (SCN #) empty.">
<INPUT TYPE="hidden" NAME="tuition_code_required" VALUE="You cannot
leave the field (Tuition Code) empty.">
<INPUT TYPE="hidden" NAME="us_area_code_required" VALUE="You cannot
leave the field (US Area Code) empty.">
<INPUT TYPE="hidden" NAME="us_phone_number_required" VALUE="You
cannot leave the field (US Phone Number) empty.">

```

```

<INPUT TYPE="hidden" NAME="us_street_required" VALUE="You cannot leave
the field (US Street) empty.">
<INPUT TYPE="hidden" NAME="us_city_required" VALUE="You cannot leave the
field (US City) empty.">
<INPUT TYPE="hidden" NAME="us_state_required" VALUE="You cannot leave
the field (US State) empty.">
<INPUT TYPE="hidden" NAME="us_zip_required" VALUE="You cannot leave the
field (US Zip Code) empty.">
<INPUT TYPE="hidden" NAME="contact_country_code_required" VALUE="You
cannot leave the field (Contact Country Code) empty.">
<INPUT TYPE="hidden" NAME="contact_area_code_required" VALUE="You
cannot leave the field (Contact Area Code) empty.">
<INPUT TYPE="hidden" NAME="contact_number_required" VALUE="You cannot
leave the field (Contact Number) empty.">
<INPUT TYPE="hidden" NAME="contact_city_required" VALUE="You cannot
leave the field (Contact City) empty.">
<INPUT TYPE="hidden" NAME="arrival_date_required" VALUE="You cannot
leave the field (Arrival Date) empty.">
<table>
<tr>
<td valign="top">
<TABLE>
<TR><TD ALIGN="right">First Name</TD><TD><INPUT TYPE="text"
NAME="ims_first_name" SIZE="15" MAXLENGTH="20"></TD></TR>
<TR><TD ALIGN="right">Middle Name</TD><TD><INPUT TYPE="text"
NAME="ims_middle_name" SIZE="15" MAXLENGTH="20"></TD></TR>
<TR><TD ALIGN="right">Last Name</TD><TD><INPUT TYPE="text"
NAME="ims_last_name" SIZE="15" MAXLENGTH="20"></TD></TR>
<TR><TD ALIGN="right">Country</TD><TD><SELECT NAME="country">
  <OPTION VALUE="Argentina">Argentina
  <OPTION VALUE="Bulgaria">Bulgaria
  <OPTION VALUE="ChileN">Chile
  <OPTION VALUE="Germany">Germany
  <OPTION VALUE="Greece">Greece
  <OPTION VALUE="Indonesia">Indonesia
  <OPTION VALUE="Turkey" SELECTED>Turkey
</SELECT></TD></TR>
<TR><TD ALIGN="right">Service</TD><TD><SELECT NAME="service">
  <OPTION VALUE="Navy" SELECTED>Navy
  <OPTION VALUE="Army">Army
  <OPTION VALUE="Airforce">Airforce
  <OPTION VALUE="Coastguard">Coastguard
  <OPTION VALUE="Civilian">Civilian
</SELECT></TD></TR>
<TR><TD ALIGN="right">Rank</TD><TD><SELECT NAME="rank">

```

```

<OPTION VALUE="1LT">1LT
<OPTION VALUE="2LT">2LT
<OPTION VALUE="Captain">Captain
<OPTION VALUE="Major">Major
<OPTION VALUE="Ltjg">Ltjg
<OPTION VALUE="Lt">Lt
<OPTION VALUE="Ltcdr">Ltcdr
</SELECT></TD></TR>
<TR><TD ALIGN="right">Gender</TD><TD><SELECT NAME="gender">
  <OPTION VALUE="Male" SELECTED>Male
  <OPTION VALUE="Female">Female
</SELECT></TD></TR>
<TR><TD ALIGN="right">Marital Status</TD><TD><SELECT
NAME="marital_status">
  <OPTION VALUE="Single" SELECTED>Single
  <OPTION VALUE="Married">Married
  <OPTION VALUE="Widow">Widow
</SELECT></TD></TR>
<TR><TD ALIGN="right">DOB</TD><TD><INPUT TYPE="text"
NAME="date_of_birth" SIZE="8" MAXLENGTH="10"></TD></TR>
<TR><TD ALIGN="right">Curriculum #</TD><TD><SELECT
NAME="curriculum_number">
  <OPTION VALUE="370" SELECTED>370
  <OPTION VALUE="360">360
  <OPTION VALUE="638">638
  <OPTION VALUE="680">680
</SELECT></TD></TR>
<TR><TD ALIGN="right">Graduation Date</TD><TD><INPUT TYPE="text"
NAME="graduation_date" VALUE="/99" SIZE="8"
MAXLENGTH="10"></TD></TR>
<TR><TD ALIGN="right">Email</TD><TD><INPUT TYPE="text" NAME="email"
VALUE="@nps.navy.mil" SIZE="25" MAXLENGTH="35"></TD></TR>
<TR><TD ALIGN="right">SGC #</TD><TD><INPUT TYPE="text"
NAME="sgc_number" SIZE="4" MAXLENGTH="5"></TD></TR>
<TR><TD ALIGN="right">SCN #</TD><TD><INPUT TYPE="text"
NAME="scn_number" VALUE="TK" SIZE="10"
MAXLENGTH="15"></TD></TR>
</table>
</td>
<td align="right">
<table>
<TR><TD ALIGN="right">Tuition Code</TD><TD><SELECT
NAME="tuition_code">
  <OPTION VALUE="FMS" SELECTED>FMS
  <OPTION VALUE="IMET">IMET

```



```

</SELECT></TD></TR>
<TR><TD ALIGN="right">US Area Code</TD><TD><INPUT TYPE="text"
NAME="us_area_code" VALUE="831" SIZE="3" MAXLENGTH="5"></TD></TR>
<TR><TD ALIGN="right">US Phone Number</TD><TD><INPUT TYPE="text"
NAME="us_phone_number" SIZE="7" MAXLENGTH="10"></TD></TR>
<TR><TD ALIGN="right">US Street</TD><TD><INPUT TYPE="text"
NAME="us_street" SIZE="25" MAXLENGTH="35"></TD></TR>
<TR><TD ALIGN="right">US City</TD><TD><INPUT TYPE="text"
NAME="us_city" VALUE="Monterey" SIZE="12"
MAXLENGTH="25"></TD></TR>
<TR><TD ALIGN="right">US State</TD><TD><INPUT TYPE="text"
NAME="us_state" VALUE="CA" SIZE="2" MAXLENGTH="15"></TD></TR>
<TR><TD ALIGN="right">US Zip Code</TD><TD><INPUT TYPE="text"
NAME="us_zip" VALUE="93940" SIZE="5" MAXLENGTH="10"></TD></TR>
<TR><TD ALIGN="right">Contact Country Code</TD><TD><INPUT TYPE="text"
NAME="contact_country_code" VALUE="90" SIZE="5"
MAXLENGTH="10"></TD></TR>
<TR><TD ALIGN="right">Contact Area Code</TD><TD><INPUT TYPE="text"
NAME="contact_area_code" SIZE="5" MAXLENGTH="10"></TD></TR>
<TR><TD ALIGN="right">Contact Phone Number</TD><TD><INPUT
TYPE="text" NAME="contact_number" SIZE="10"
MAXLENGTH="20"></TD></TR>
<TR><TD ALIGN="right">Contact Street</TD><TD><INPUT TYPE="text"
NAME="contact_street" SIZE="25" MAXLENGTH="35"></TD></TR>
<TR><TD ALIGN="right">Contact City</TD><TD><INPUT TYPE="text"
NAME="contact_city" VALUE="Istanbul" SIZE="12"
MAXLENGTH="25"></TD></TR>
<TR><TD ALIGN="right">Contact State</TD><TD><INPUT TYPE="text"
NAME="contact_state" SIZE="10" MAXLENGTH="20"></TD></TR>
<TR><TD ALIGN="right">Arrival Date</TD><TD><INPUT TYPE="text"
NAME="arrival_date" SIZE="8" MAXLENGTH="10"></TD></TR>
<TR><TD ALIGN="right">Comments</TD><TD><TEXTAREA
NAME="comments" COLS="20" ROWS="3"></TEXTAREA></TD></TR>
</TABLE>
</td>
</tr>
</table>
<br>
<center>
<table>
<tr>
<td align="center">
<INPUT TYPE="submit" VALUE="Submit"></td>
<td align="center"><INPUT TYPE="reset" VALUE="Reset"></td>
</tr>

```



```
</table>  
</center>  
</FORM>  
</BODY>  
</HTML>
```



## Data Entry Form For IMS Dependent

---

IMS First Name

IMS Last Name

Relation

First Name

Last Name

Date of Birth

```

<HTML>
<HEAD><TITLE>Data Entry Form For IMS Dependant</TITLE></HEAD>
<BODY bgcolor="#000173" text="#FDD708" LINK="#FDD708"
vlink="#FDD708">
<basefont face="arial, helvetica">
<center>
<TABLE>
<TR>
<TD><IMG SRC="nps.gif" width="70" height="70"></td>
<TD ALIGN="CENTER"><H2>Data Entry Form For IMS Dependent</H2></TD>
</tr>
</table>
</center>
<HR NOSHADE>
<FORM ACTION="DataEntryIMSD.CFM" METHOD="POST">
<INPUT TYPE="hidden" NAME="ims_first_name_required" VALUE="You cannot
leave the field (First Name) empty.">
<INPUT TYPE="hidden" NAME="ims_last_name_required" VALUE="You cannot
leave the field (Last Name) empty.">
<INPUT TYPE="hidden" NAME="relation_required" VALUE="You cannot leave
the field (Relation) empty.">
<INPUT TYPE="hidden" NAME="first_name_required" VALUE="You cannot leave
the field (First Name) empty.">
<INPUT TYPE="hidden" NAME="last_name_required" VALUE="You cannot leave
the field (Last Name) empty.">
<INPUT TYPE="hidden" NAME="date_of_birth_required" VALUE="You cannot
leave the field (Date of Birth) empty.">
<TABLE>
<TR><TD ALIGN="right">IMS First Name</TD><TD><INPUT TYPE="text"
NAME="ims_first_name" SIZE="20" MAXLENGTH="30"></TD></TR>
<TR><TD ALIGN="right">IMS Last Name</TD><TD><INPUT TYPE="text"
NAME="ims_last_name" SIZE="20" MAXLENGTH="25"></TD></TR>
<TR><TD ALIGN="right">Relation</TD><TD><SELECT NAME="relation">
<OPTION VALUE="Wife" SELECTED>Wife
<OPTION VALUE="Son">Son
<OPTION VALUE="Daughter">Daughter
<OPTION VALUE="Mother">Mother
</SELECT></TD></TR>
<TR><TD ALIGN="right">First Name</TD><TD><INPUT TYPE="text"
NAME="first_name" SIZE="20" MAXLENGTH="25"></TD></TR>
<TR><TD ALIGN="right">Last Name</TD><TD><INPUT TYPE="text"
NAME="last_name" SIZE="20" MAXLENGTH="30"></TD></TR>
<TR><TD ALIGN="right">Date of Birth</TD><TD><INPUT TYPE="text"
NAME="date_of_birth" VALUE="MM/DD/YY" SIZE="12"
MAXLENGTH="15"></TD></TR>

```

```
</TABLE>
<br><br>
<CENTER>
<table><tr>
<td align="center"><INPUT TYPE="submit" VALUE="Submit"></td>
<td align="center"><INPUT TYPE="reset" VALUE="Reset"></td>
</tr>
</table>
</center>
</FORM>
</BODY>
</HTML>
```



# Data Entry Form For Sponsor

IMS First Name	<input type="text"/>	Email	<input type="text" value="@nps.navy.mil"/>
IMS Last Name	<input type="text"/>	Curriculum #	<input type="text" value="370"/>
First Name	<input type="text"/>	Area Code #	<input type="text" value="831"/>
Middle Name	<input type="text"/>	Phone #	<input type="text"/>
Last Name	<input type="text"/>	Street	<input type="text"/>
Country	<input type="text" value="USA"/>	City	<input type="text" value="Monterey"/>
Service	<input type="text" value="Navy"/>	State	<input type="text" value="CA"/>
Rank	<input type="text" value="Ltjg"/>	Zip	<input type="text" value="93940"/>
DOB	<input type="text" value="MM/DD/YY"/>	SGC #	<input type="text"/>
Gender	<input type="text" value="Male"/>	SSN #	<input type="text"/>
Graduation Date	<input type="text" value="MM/DD/YY"/>	DOA	<input type="text" value="MM/DD/YY"/>
Marital Status	<input type="text" value="Single"/>	Comments	<input type="text"/>

```

<HTML>
<HEAD><TITLE>Data Entry Form For Sponsor</TITLE></HEAD>
<BODY bgcolor="#000173" text="#FDD708" LINK="#FDD708"
vlink="#FDD708">
<basefont face="arial, helvetica">
<center>
<TABLE>
<TR>
<TD><IMG SRC="nps.gif" width="70" height="70"></td>
<TD ALIGN="CENTER"><H2>Data Entry Form For Sponsor</H2></TD>
</tr>
</table>
</center>
<HR NOSHADE>
<FORM ACTION="DataEntrySPONSOR.CFM" METHOD="POST">
<INPUT TYPE="hidden" NAME="ims_first_name_required" VALUE="You cannot
leave the field (IMS First Name) empty.">
<INPUT TYPE="hidden" NAME="ims_last_name_required" VALUE="You cannot
leave the field (IMS Last Name) empty.">
<INPUT TYPE="hidden" NAME="sponsor_first_name_required" VALUE="You
cannot leave the field (First Name) empty.">
<INPUT TYPE="hidden" NAME="sponsor_last_name_required" VALUE="You
cannot leave the field (Last Name) empty.">
<INPUT TYPE="hidden" NAME="country_required" VALUE="You cannot leave
the field (Country) empty.">
<INPUT TYPE="hidden" NAME="service_required" VALUE="You cannot leave the
field (Service) empty.">
<INPUT TYPE="hidden" NAME="rank_required" VALUE="You cannot leave the
field (Rank) empty.">
<INPUT TYPE="hidden" NAME="date_of_birth_required" VALUE="You cannot
leave the field (DOB) empty.">
<INPUT TYPE="hidden" NAME="gender_required" VALUE="You cannot leave the
field (Gender) empty.">
<INPUT TYPE="hidden" NAME="date_of_graduation_required" VALUE="You
cannot leave the field (Graduation Date) empty.">
<INPUT TYPE="hidden" NAME="marital_status_required" VALUE="You cannot
leave the field (Marital Status) empty.">
<INPUT TYPE="hidden" NAME="email_required" VALUE="You cannot leave the
field (Email) empty.">
<INPUT TYPE="hidden" NAME="curriculum_number_required" VALUE="You
cannot leave the field (Curriculum #) empty.">
<INPUT TYPE="hidden" NAME="phone_area_code_required" VALUE="You
cannot leave the field (Area Code #) empty.">
<INPUT TYPE="hidden" NAME="phone_number_required" VALUE="You cannot
leave the field (Phone #) empty.">

```



```

<INPUT TYPE="hidden" NAME="street_required" VALUE="You cannot leave the
field (Street) empty.">
<INPUT TYPE="hidden" NAME="city_required" VALUE="You cannot leave the
field (City) empty.">
<INPUT TYPE="hidden" NAME="state_required" VALUE="You cannot leave the
field (State) empty.">
<INPUT TYPE="hidden" NAME="zip_required" VALUE="You cannot leave the
field (Zip) empty.">
<INPUT TYPE="hidden" NAME="sgc_number_required" VALUE="You cannot
leave the field (SGC #) empty.">
<INPUT TYPE="hidden" NAME="ssn_number_required" VALUE="You cannot
leave the field (SSN #) empty.">
<INPUT TYPE="hidden" NAME="date_of_assignment_required" VALUE="You
cannot leave the field (DOA) empty.">
<table>
<tr>
<td valign="top">
<TABLE>
<TR><TD ALIGN="right">IMS First Name</TD><TD><INPUT TYPE="text"
NAME="ims_first_name" SIZE="20" MAXLENGTH="25"></TD></TR>
<TR><TD ALIGN="right">IMS Last Name</TD><TD><INPUT TYPE="text"
NAME="ims_last_name" SIZE="20" MAXLENGTH="25"></TD></TR>
<TR><TD ALIGN="right">First Name</TD><TD><INPUT TYPE="text"
NAME="sponsor_first_name" SIZE="20" MAXLENGTH="30"></TD></TR>
<TR><TD ALIGN="right">Middle Name</TD><TD><INPUT TYPE="text"
NAME="middle_name" SIZE="20" MAXLENGTH="30"></TD></TR>
<TR><TD ALIGN="right">Last Name</TD><TD><INPUT TYPE="text"
NAME="sponsor_last_name" SIZE="20" MAXLENGTH="30"></TD></TR>
<TR><TD ALIGN="right">Country</TD><TD><SELECT NAME="country">
  <OPTION VALUE="USA" SELECTED>USA
  <OPTION VALUE="Canada">Canada
</SELECT></TD></TR>
<TR><TD ALIGN="right">Service</TD><TD><SELECT NAME="service">
  <OPTION VALUE="Navy" SELECTED>Navy
  <OPTION VALUE="Army">Army
  <OPTION VALUE="Airforce">Airforce
  <OPTION VALUE="Coastguard">Coastguard
  <OPTION VALUE="Civilian">Civilian
</SELECT></TD></TR>
<TR><TD ALIGN="right">Rank</TD><TD><SELECT NAME="rank">
  <OPTION VALUE="Ltjg">Ltjg
  <OPTION VALUE="Lt">Lt
  <OPTION VALUE="Ltcdrr">Ltcdrr
  <OPTION VALUE="1lt">1Lt
  <OPTION VALUE="2lt">2Lt

```

```

    <OPTION VALUE="Captain">Captain
    <OPTION VALUE="Major">Major
    </SELECT></TD></TR>
<TR><TD ALIGN="right">DOB</TD><TD><INPUT TYPE="text"
NAME="date_of_birth" VALUE="MM/DD/YY" SIZE="12"
MAXLENGTH="15"></TD></TR>
<TR><TD ALIGN="right">Gender</TD><TD><SELECT NAME="gender">
    <OPTION VALUE="Male" SELECTED>Male
    <OPTION VALUE="Female">Female
    </SELECT></TD></TR>
<TR><TD ALIGN="right">Graduation Date</TD><TD><INPUT TYPE="text"
NAME="date_of_graduation" VALUE="MM/DD/YY" SIZE="12"
MAXLENGTH="15"></TD></TR>
<TR><TD ALIGN="right">Marital Status</TD><TD><SELECT
NAME="marital_status">
    <OPTION VALUE="Single" SELECTED>Single
    <OPTION VALUE="Married">Married
    <OPTION VALUE="Widow">Widow
    </SELECT></TD></TR>
</table>
</td>
<td align="right">
<table>
<TR><TD ALIGN="right">Email</TD><TD><INPUT TYPE="text" NAME="email"
VALUE="@nps.navy.mil" SIZE="20" MAXLENGTH="30"></TD></TR>
<TR><TD ALIGN="right">Curriculum #</TD><TD><SELECT
NAME="curriculum_number">
    <OPTION VALUE="370" SELECTED>370
    <OPTION VALUE="360">360
    <OPTION VALUE="838">838
    <OPTION VALUE="630">630
    </SELECT></TD></TR>
<TR><TD ALIGN="right">Area Code #</TD><TD><INPUT TYPE="text"
NAME="phone_area_code" VALUE="831" SIZE="4"
MAXLENGTH="5"></TD></TR>
<TR><TD ALIGN="right">Phone #</TD><TD><INPUT TYPE="text"
NAME="phone_number" SIZE="10" MAXLENGTH="12"></TD></TR>
<TR><TD ALIGN="right">Street</TD><TD><INPUT TYPE="text"
NAME="street" SIZE="20" MAXLENGTH="30"></TD></TR>
<TR><TD ALIGN="right">City</TD><TD><INPUT TYPE="text" NAME="city"
VALUE="Monterey" SIZE="20" MAXLENGTH="30"></TD></TR>
<TR><TD ALIGN="right">State</TD><TD><INPUT TYPE="text" NAME="state"
VALUE="CA" SIZE="3" MAXLENGTH="4"></TD></TR>
<TR><TD ALIGN="right">Zip</TD><TD><INPUT TYPE="text" NAME="zip"
VALUE="93940" SIZE="5" MAXLENGTH="10"></TD></TR>

```

```

<TR><TD ALIGN="right">SGC #</TD><TD><INPUT TYPE="text"
NAME="sgc_number" SIZE="5" MAXLENGTH="8"></TD></TR>
<TR><TD ALIGN="right">SSN #</TD><TD><INPUT TYPE="text"
NAME="ssn_number" SIZE="10" MAXLENGTH="15"></TD></TR>
<TR><TD ALIGN="right">DOA</TD><TD><INPUT TYPE="text"
NAME="date_of_assignment" VALUE="MM/DD/YY" SIZE="12"
MAXLENGTH="15"></TD></TR>
<TR><TD ALIGN="right">Comments</TD><TD><TEXTAREA
NAME="comments" COLS="20" ROWS="4"></TEXTAREA></TD></TR>
</TABLE>
</td>
</tr>
</table>
<br><br>
<CENTER>
<table><tr>
<td align="center"><INPUT TYPE="submit" VALUE="Submit"></td>
<td align="center"><INPUT TYPE="reset" VALUE="Reset"></td>
</tr>
</table>
</center>
</FORM>
</BODY>
</HTML>

```



## Data Entry Form For Sponsor Dependent

---

Sponsor First Name

Sponsor Last Name

Relation

First Name

Last Name

DOB



```

<HTML>
<HEAD><TITLE>Data Entry Form For Sponsor Dependent</TITLE></HEAD>
<BODY bgcolor="#000173" text="#FDD708" LINK="#FDD708"
vlink="#FDD708">
<basefont face="arial, helvetica">
<center>
<TABLE>
<TR>
<TD><IMG SRC="nps.gif" width="70" height="70"></td>
<TD ALIGN="CENTER"><H2>Data Entry Form For Sponsor
Dependent</H2></TD>
</tr>
</table>
</center>
<HR NOSHADE>
<FORM ACTION="DataEntrySPONSORD.CFM" METHOD="POST">
<INPUT TYPE="hidden" NAME="sponsor_first_name_required" VALUE="You
cannot leave the field (sponsor_first_name) empty.">
<INPUT TYPE="hidden" NAME="sponsor_last_name_required" VALUE="You
cannot leave the field (Sponsor Last Name) empty.">
<INPUT TYPE="hidden" NAME="relation_required" VALUE="You cannot leave
the field (Relation) empty.">
<INPUT TYPE="hidden" NAME="first_name_required" VALUE="You cannot leave
the field (First Name) empty.">
<INPUT TYPE="hidden" NAME="last_name_required" VALUE="You cannot leave
the field (Last Name) empty.">
<INPUT TYPE="hidden" NAME="date_of_birth_required" VALUE="You cannot
leave the field (DOB) empty.">
<TABLE>
<TR><TD ALIGN="right">Sponsor First Name</TD><TD><INPUT TYPE="text"
NAME="sponsor_first_name" SIZE="20" MAXLENGTH="30"></TD></TR>
<TR><TD ALIGN="right">Sponsor Last Name</TD><TD><INPUT TYPE="text"
NAME="sponsor_last_name" SIZE="20" MAXLENGTH="30"></TD></TR>
<TR><TD ALIGN="right">Relation</TD><TD><SELECT NAME="relation">
<OPTION VALUE="Wife" SELECTED>Wife
<OPTION VALUE="Son">Son
<OPTION VALUE="Daughter">Daughter
</SELECT></TD></TR>
<TR><TD ALIGN="right">First Name</TD><TD><INPUT TYPE="text"
NAME="first_name" SIZE="20" MAXLENGTH="30"></TD></TR>
<TR><TD ALIGN="right">Last Name</TD><TD><INPUT TYPE="text"
NAME="last_name" SIZE="20" MAXLENGTH="30"></TD></TR>

```

```
<TR><TD ALIGN="right">DOB</TD><TD><INPUT TYPE="text"
NAME="date_of_birth" SIZE="20" MAXLENGTH="30"></TD></TR>
</TABLE>
<br><br>
<CENTER>
<table><tr>
<td align="center"><INPUT TYPE="submit" VALUE="Submit"></td>
<td align="center"><INPUT TYPE="reset" VALUE="Reset"></td>
</tr>
</table>
</center>
</FORM>
</BODY>
</HTML>
```





## IMS Search Page

---

IMS First Name

IMS Last Name

Country

```

<HTML>
<HEAD><TITLE>IMS Search Page</TITLE></HEAD>
<BODY bgcolor="#000173" text="#FDD708" LINK="#FDD708"
vlink="#FDD708">
<basefont face="arial, helvetica">
<center>
<TABLE>
<TR>
<TD><IMG SRC="nps.gif" width="70" height="70"></td>
<TD ALIGN="CENTER"><H2>IMS Search Page</H2></TD>
</tr>
</table>
</center>
<HR NOSHADE>
<FORM ACTION="Results.CFM" METHOD="POST">
<TABLE>
<TR><TD ALIGN="right">IMS First Name</TD><TD><INPUT TYPE="text"
NAME="ims__ims_first_name" SIZE="15" MAXLENGTH="20"></TD></TR>
<TR><TD ALIGN="right">IMS Last Name</TD><TD><INPUT TYPE="text"
NAME="ims__ims_last_name" SIZE="15" MAXLENGTH="20"></TD></TR>
<TR><TD ALIGN="right">Country</TD><TD><INPUT TYPE="text"
NAME="ims__country" SIZE="15" MAXLENGTH="20"></TD></TR>
</TABLE>
<br><br>
<CENTER>
<table><tr>
<td align="center"><INPUT TYPE="submit" VALUE="Submit"></td>
<td align="center"><INPUT TYPE="reset" VALUE="Reset"></td>
</tr>
</table>
</center>
</FORM>
</BODY>
</HTML>

```



## IMS Dependent Search Page

---

First Name

IMS Last Name

```

<HTML>
<HEAD><TITLE>IMS Search Page</TITLE></HEAD>
<BODY bgcolor="#000173" text="#FDD708" LINK="#FDD708"
vlink="#FDD708">
<basefont face="arial, helvetica">
<center>
<TABLE>
<TR>
<TD><IMG SRC="nps.gif" width="70" height="70"></td>
<TD ALIGN="CENTER"><H2>IMS Search Page</H2></TD>
</tr>
</table>
</center>
<HR NOSHADE>
<FORM ACTION="Results.CFM" METHOD="POST">
<TABLE>
<TR><TD ALIGN="right">IMS First Name</TD><TD><INPUT TYPE="text"
NAME="ims__ims_first_name" SIZE="15" MAXLENGTH="20"></TD></TR>
<TR><TD ALIGN="right">IMS Last Name</TD><TD><INPUT TYPE="text"
NAME="ims__ims_last_name" SIZE="15" MAXLENGTH="20"></TD></TR>
<TR><TD ALIGN="right">Country</TD><TD><INPUT TYPE="text"
NAME="ims__country" SIZE="15" MAXLENGTH="20"></TD></TR>
</TABLE>
<br><br>
<CENTER>
<table><tr>
<td align="center"><INPUT TYPE="submit" VALUE="Submit"></td>
<td align="center"><INPUT TYPE="reset" VALUE="Reset"></td>
</tr>
</table>
</center>
</FORM>
</BODY>
</HTML>

```



## Sponsor Search Page

---

Sponsor First Name

Sponsor Last Name

```

<HTML>
<HEAD><TITLE>Sponsor Search Page</TITLE></HEAD>
<BODY bgcolor="#000173" text="#FDD708" LINK="#FDD708"
vlink="#FDD708">
<basefont face="arial, helvetica">
<center>
<TABLE>
<TR>
<TD><IMG SRC="nps.gif" width="70" height="70"></td>
<TD ALIGN="CENTER"><H2>Sponsor Search Page</H2></TD>
</tr>
</table>
</center>
<HR NOSHADE>
<FORM ACTION="Results.CFM" METHOD="POST">
<TABLE>
<TR><TD ALIGN="right">Sponsor First Name</TD><TD><INPUT TYPE="text"
NAME="sponsor__sponsor_first_name" SIZE="12"
MAXLENGTH="20"></TD></TR>
<TR><TD ALIGN="right">Sponsor Last Name</TD><TD><INPUT TYPE="text"
NAME="sponsor__sponsor_last_name" SIZE="12"
MAXLENGTH="20"></TD></TR>
</TABLE>
<br><br>
<CENTER>
<table><tr>
<td align="center"><INPUT TYPE="submit" VALUE="Submit"></td>
<td align="center"><INPUT TYPE="reset" VALUE="Reset"></td>
</tr>
</table>
</center>
</FORM>
</BODY>
</HTML>

```





## Sponsor Dependent Search Page

---

First Name

Sponsor Last Name

```

<HTML>
<HEAD><TITLE>Sponsor Dependent Search Page</TITLE></HEAD>
<BODY bgcolor="#000173" text="#FDD708" LINK="#FDD708"
vlink="#FDD708">
<basefont face="arial, helvetica">
<center>
<TABLE>
<TR>
<TD><IMG SRC="nps.gif" width="70" height="70"></td>
<TD ALIGN="CENTER"><H2>Sponsor Dependent Search Page</H2></TD>
</tr>
</table>
</center>
<HR NOSHADE>
<FORM ACTION="Results.CFM" METHOD="POST">
<TABLE>
<TR><TD ALIGN="right">First Name</TD><TD><INPUT TYPE="text"
NAME="sponsor_dependant_first_name" SIZE="15"
MAXLENGTH="20"></TD></TR>
<TR><TD ALIGN="right">Sponsor Last Name</TD><TD><INPUT TYPE="text"
NAME="sponsor_dependant_sponsor_last_name" SIZE="15"
MAXLENGTH="20"></TD></TR>
</TABLE>
<br><br>
<CENTER>
<table><tr>
<td align="center"><INPUT TYPE="submit" VALUE="Submit"></td>
<td align="center"><INPUT TYPE="reset" VALUE="Reset"></td>
</tr>
</table>
</center>
</FORM>
</BODY>
</HTML>

```

## IMS Update Info

---

Please, Enter the SGC Number of the IMS then click **Process**

IMS SGC #:

```
<HTML>
<HEAD>
<TITLE>Enter Data For Update</TITLE>
</HEAD>
<BODY bgcolor="blue">
<font color="yellow">
<center>
<BR>
<h2>IMS Update Info</h2>
<HR NOSHADE>
<FORM ACTION="update1IMS.CFM" METHOD="POST">
Please, Enter the SGC Number of the IMS then click <b>Process</b>
<br>
<br>
IMS SGC #:
<input TYPE="text" NAME="sgc_number">
<BR>
<BR>
<input TYPE="submit" VALUE="Process">
</form>
</font>
</body>
</html>
```

## IMS Dependent Update Info

---

IMS Dependent First Name:

IMS Dependent Last Name:

```
<HTML>
<HEAD>
<TITLE>Enter Data For Update</TITLE>
</HEAD>
<BODY bgcolor="blue">
<font color='yellow'>
<center>
<BR>
<br>
<h2>IMS Dependent Update Info</h2>
<HR NOSHADE>
<br>
<FORM ACTION="update1IMSD.CFM" METHOD="POST">
<br>
IMS Dependent First Name:
<input TYPE="text" NAME="first_name">
<br>
IMS Dependent Last Name:
<input TYPE="text" NAME="last_name">
<BR>
<BR>
<input TYPE="submit" VALUE="Process">
</form>
</font>
</body>
</html>
```



## Sponsor Update Info

---

Please, Enter the Last Name of the Sponsor then click **Process**

SGC Number:

```
<HTML>
<HEAD>
<TITLE>Enter Data For Update</TITLE>
</HEAD>
<BODY bgcolor="blue">
<font color="yellow">
<center>
<BR>
<h2>Sponsor Update Info</h2>
<HR NOSHADE>
<FORM ACTION="update1SPONSOR.CFM" METHOD="POST">
Please, Enter the Last Name of the Sponsor then click <b>Process</b>
<br>
<br>
SGC Number:
<input TYPE="text" NAME="sgc_number">
<BR>
<br>
<input TYPE="submit" VALUE="Process">
</form>
</font>
</body>
</html>
```

## Sponsor Dependent Update Info

---

Sponsor Dependent First Name:

Sponsor Dependent Last Name:

```
<HTML>
<HEAD>
<TITLE>Enter Data For Update</TITLE>
</HEAD>
<BODY bgcolor="blue">
<font color="yellow">
<center>
<BR>
<br>
<h2>Sponsor Dependent Update Info</h2>
<HR NOSHADE>
<br>
<FORM ACTION="update1SPONSORD.CFM" METHOD="POST">
<br>
Sponsor Dependent First Name:
<input TYPE="text" NAME="first_name">
<br>
Sponsor Dependent Last Name:
<input TYPE="text" NAME="last_name">
<BR>
<BR>
<input TYPE="submit" VALUE="Process">
</form>
</font>
</body>
</html>
```

## IMS Delete Info

---

Please, Enter the SGC Number of the IMS then click **Process**

IMS SGC #:

```
<HTML>
<HEAD>
<TITLE>Enter Data For Delete</TITLE>
</HEAD>
<BODY bgcolor="blue">
<font color="yellow">
<center>
<BR>
<h2>IMS Delete Info</h2>
<HR NOSHADE>
<FORM ACTION="delete1IMS.CFM" METHOD="POST">
Please, Enter the SGC Number of the IMS then click <b>Process</b>
<br>
<br>
IMS SGC #:
<input TYPE="text" NAME="sgc_number">
<BR>
<BR>
<input TYPE="submit" VALUE="Process">
</form>
</font>
</body>
</html>
```



## IMS Dependent Delete Info

---

Please, Enter the Name and the Last Name of the IMS Dependent then click **Process**

IMS Dependent First Name:

IMS Dependent Last Name:

```
<HTML>
<HEAD>
<TITLE>Enter Data For Delete</TITLE>
</HEAD>
<BODY bgcolor="blue">
<font color="yellow">
<center>
<BR>
<h2>IMS Dependent Delete Info</h2>
<HR NOSHADE>
<FORM ACTION="delete1IMSD.CFM" METHOD="POST">
Please, Enter the Name and the Last Name of the IMS Dependent then click
<b>Process</b>
<br>
<br>
IMS Dependent First Name:
<input TYPE="text" NAME="first_name">
<br>
IMS Dependent Last Name:
<input TYPE="text" NAME="last_name">
<br>
<br>
<input TYPE="submit" VALUE="Process">
</form>
</font>
</body>
</html>
```

## Sponsor Delete Info

---

Please, Enter the Name and the Last Name of the Sponsor then click **Process**

Sponsor First Name:

Sponsor Last Name:

```
<HTML>
<HEAD>
<TITLE>Enter Data For Delete</TITLE>
</HEAD>
<BODY bgcolor="blue">
<font color="yellow">
<center>
<BR>
<h2>Sponsor Delete Info</h2>
<HR NOSHADE>
<FORM ACTION="delete1SPONSOR.CFM" METHOD="POST">
Please, Enter the Name and the Last Name of the Sponsor then click <b>Process</b>
<br>
<br>
Sponsor First Name:
<input TYPE="text" NAME="sponsor_first_name">
<br>
Sponsor Last Name:
<input TYPE="text" NAME="sponsor_last_name">
<br>
<br>
<input TYPE="submit" VALUE="Process">
</form>
</font>
</body>
</html>
```

## Sponsor Dependent Delete Info

---

Please, Enter the Name and the Last Name of the Sponsor Dependent then click **Process**

Sponsor Dependent First Name:

Sponsor Dependent Last Name:

```
<HTML>
<HEAD>
<TITLE>Enter Data For Delete</TITLE>
</HEAD>
<BODY bgcolor="blue">
<font color="yellow">
<center>
<BR>
<h2>Sponsor Dependent Delete Info</h2>
<HR NOSHADE>
<FORM ACTION="delete1SPONSORD.CFM" METHOD="POST">
Please, Enter the Name and the Last Name of the Sponsor Dependent then click
<b>Process</b>
<br>
<br>
Sponsor Dependent First Name:
<input TYPE="text" NAME="first_name">
<br>
Sponsor Dependent Last Name:
<input TYPE="text" NAME="last_name">

<br>
<br>
<input TYPE="submit" VALUE="Process">
</form>
</font>
</body>
</html>
```



## INITIAL DISTRIBUTION LIST

1. Defense Technical Information Center.....2  
8725 John J. Kingman Rd., STE 0944  
Ft. Belvoir, VA 22060-6218
2. Dudley Knox Library.....2  
Naval Postgraduate School  
411 Dyer Rd.  
Monterey, CA 93943-5101
3. Prof. James C. Emery, Code SM/Ey.....1  
Department of Systems Management  
Naval Postgraduate School  
Monterey, CA 93943
4. Prof. Daniel R. Dolk, Code SM/Dk.....1  
Department of Systems Management  
Naval Postgraduate School  
Monterey, CA 93943
5. Major Asep Sumaruddin.....1  
Jl. Kolatu 13  
Lanud Halim Perdanakusuma  
Jakarta 13610  
Indonesia
6. LTJG Ferit Tolga Ayan.....1  
Sirmakes Sokak Oylum Sitesi A Blok No: 8 D: 4  
Altintepe - Istanbul - Turkey
7. Deniz Kuvvetleri Komutanligi.....1  
Personel Daire Baskanligi  
Bakanliklar - Ankara - Turkey





69 290NP6 2974  
TH  
6/02 22527-200 NLE











DUDLEY KNOX LIBRARY



3 2768 00410653 4