

# NAVAL POSTGRADUATE SCHOOL Monterey, California



## THESIS

**PROPAGATION OF FIRE GENERATED SMOKE IN  
SHIPBOARD SPACES WITH GEOMETRIC  
INTERFERENCES**

by

Amado F. Abaya, Jr.

September 2000

Thesis Advisor:

Matthew D. Kelleher

**Approved for public release; distribution is unlimited.**

THESIS  
A11385



<b>REPORT DOCUMENTATION PAGE</b>			Form Approved OMB No. 0704-0188	
Public reporting burden for this collection of information is estimated to average 1 hour per response, including the time for reviewing instruction, searching existing data sources, gathering and maintaining the data needed, and completing and reviewing the collection of information. Send comments regarding this burden estimate or any other aspect of this collection of information, including suggestions for reducing this burden, to Washington headquarters Services, Directorate for Information Operations and Reports, 1215 Jefferson Davis Highway, Suite 1204, Arlington, VA 22202-4302, and to the Office of Management and Budget, Paperwork Reduction Project (0704-0188) Washington DC 20503.				
<b>1. AGENCY USE ONLY (Leave blank)</b>		<b>2. REPORT DATE</b> September 2000	<b>3. REPORT TYPE AND DATES COVERED</b> Master's Thesis	
<b>4. TITLE AND SUBTITLE:</b> Propagation of Fire Generated Smoke in Shipboard Spaces with Geometric Interferences			<b>5. FUNDING NUMBERS</b>	
<b>6. AUTHOR(S)</b> Amado F. Abaya, Jr				
<b>7. PERFORMING ORGANIZATION NAME(S) AND ADDRESS(ES)</b> Naval Postgraduate School Monterey, CA 93943-5000			<b>8. PERFORMING ORGANIZATION REPORT NUMBER</b>	
<b>9. SPONSORING / MONITORING AGENCY NAME(S) AND ADDRESS(ES)</b> N/A			<b>10. SPONSORING / MONITORING AGENCY REPORT NUMBER</b>	
<b>11. SUPPLEMENTARY NOTES</b> The views expressed in this thesis are those of the author and do not reflect the official policy or position of the Department of Defense or the U.S. Government.				
<b>12a. DISTRIBUTION / AVAILABILITY STATEMENT</b> Approved for public release; distribution is unlimited.			<b>12b. DISTRIBUTION CODE</b>	
<b>13. ABSTRACT (maximum 200 words)</b> The propagation of fire generated smoke into a shipboard space with a geometric interference has been modeled using commercial software from the Computational Fluid Dynamics Research Corporation (CFDRC). This study was based on the dimensions of compartment 01-163-2-L and the installed ladder aboard an Arleigh Burke Class Flight IIIA Destroyer. A test model was run which validated the hindrance of fluid flow by a geometric interference. Smoke propagation scenarios were run in the shipboard compartment model. The results of the first scenario showed that smoke propagation is limited by the geometric interference. The results of the second scenario showed that smoke that is directed vertically is diverted by the geometric interference. The overall goal of this study is to show that computational fluid dynamics software can successfully model smoke propagation in shipboard spaces with a geometric interference.				
<b>14. SUBJECT TERMS</b> Convection, Smoke Modeling, and Computational Fluid Dynamics.			<b>15. NUMBER OF PAGES</b> 76	
			<b>16. PRICE CODE</b>	
<b>17. SECURITY CLASSIFICATION OF REPORT</b> Unclassified	<b>18. SECURITY CLASSIFICATION OF THIS PAGE</b> Unclassified	<b>19. SECURITY CLASSIFICATION OF ABSTRACT</b> Unclassified	<b>20. LIMITATION OF ABSTRACT</b> UL	

THIS PAGE INTENTIONALLY LEFT BLANK

**Approved for public release; distribution is unlimited.**

**PROPAGATION OF FIRE GENERATED SMOKE IN SHIPBOARD SPACES  
WITH GEOMETRIC INTERFERENCES**

Amado F. Abaya, Jr.  
Lieutenant, United States Navy  
B.S., Miami University of Ohio, 1993

Submitted in partial fulfillment of the  
requirements for the degree of

**MASTER OF SCIENCE IN MECHANICAL ENGINEERING**

from the

**NAVAL POSTGRADUATE SCHOOL  
September 2000**



## ABSTRACT

The propagation of fire generated smoke into a shipboard space with a geometric interference has been modeled using commercial software from the Computational Fluid Dynamics Research Corporation (CFDRC). This study was based on the dimensions of compartment 01-163-2-L and the installed ladder aboard an Arleigh Burke Class Flight IIIA Destroyer. A test model was run which validated the hindrance of fluid flow by a geometric interference. Smoke propagation scenarios were run in the shipboard compartment model. The results of the first scenario showed that smoke propagation is limited by the geometric interference. The results of the second scenario showed that smoke that is directed vertically is diverted by the geometric interference. The overall goal of this study is to show that computational fluid dynamics software can successfully model smoke propagation in shipboard spaces with a geometric interference.

THIS PAGE INTENTIONALLY LEFT BLANK



## TABLE OF CONTENTS

<b>I.</b>	<b>INTRODUCTION .....</b>	<b>1</b>
	<b>A. BACKGROUND .....</b>	<b>1</b>
	<b>B. DESCRIPTION OF PROBLEM .....</b>	<b>3</b>
	<b>C. PREVIOUS WORK .....</b>	<b>4</b>
	<b>D. OBJECTIVES .....</b>	<b>6</b>
<b>II.</b>	<b>COMPUTATIONAL FLUID DYNAMICS.....</b>	<b>7</b>
	<b>A. OVERVIEW .....</b>	<b>7</b>
	<b>B. FINITE VOLUME ANALYSIS.....</b>	<b>8</b>
<b>III.</b>	<b>MODEL .....</b>	<b>11</b>
	<b>A. GEOMETRY.....</b>	<b>11</b>
	<b>B. GRID GENERATION .....</b>	<b>12</b>
	<b>C. VOLUME GENERATION.....</b>	<b>15</b>
	<b>D. MODEL GENERATION.....</b>	<b>15</b>
<b>IV.</b>	<b>RESULTS .....</b>	<b>17</b>
<b>V.</b>	<b>CONCLUSIONS.....</b>	<b>19</b>
<b>VI.</b>	<b>RECOMMENDATIONS.....</b>	<b>21</b>
	<b>APPENDIX A .....</b>	<b>23</b>
	<b>APPENDIX B .....</b>	<b>29</b>
	<b>APPENDIX C.....</b>	<b>37</b>
	<b>LIST OF REFERENCES.....</b>	<b>43</b>
	<b>INITIAL DISTRIBUTION LIST .....</b>	<b>45</b>



# I. INTRODUCTION

## A. BACKGROUND

Throughout US naval history, fighting a shipboard fire has been the number one damage control priority. Aboard a ship, evacuation from a fire is not a choice. In a recent event, the USS STARK (FFG 31) was struck by two Iraqi Exocet missiles while on patrol in the Arabian Gulf. Both missiles entered on the port side of the STARK but most of the damage was on the starboard side [Figure 1]. The first missile failed to detonate but spread deadly burning propellant in its path. The burning propellant generated extremely high temperatures causing thermal damage and enormous amounts of smoke. The second missile detonated within the skin of the ship leaving a gaping hole in the hull. This hole fed oxygen to the fires caused by the extreme temperatures. Decks and electrical cableways melted from the 3000° F(1922° K) temperature produced from the burning propellant. The crew of the STARK fought the high temperature fire that produced tremendous amount of smoke and toxic fumes.

‘The heat and smoke were tremendous,’ LT Carl S. Barbour recalled. For example, when I cracked the hatch from the mess decks by the scullery, it felt as if the fire was right there. Yet, we didn't find flames until we got all the way to the rear of the CPO berthing.[Ref 1]

The crew's fire fighting capabilities were limited by the dense smoke, toxic fumes and the US Navy's fire fighting technology. It was impossible to fight the fire through the smoke and fumes as the missile propellant burned unabated. Fighting this weapon-induced fire was new to the US Navy. Today, weapon-induced fires remains a hazard even with the newest fire fighting technology aboard ship.



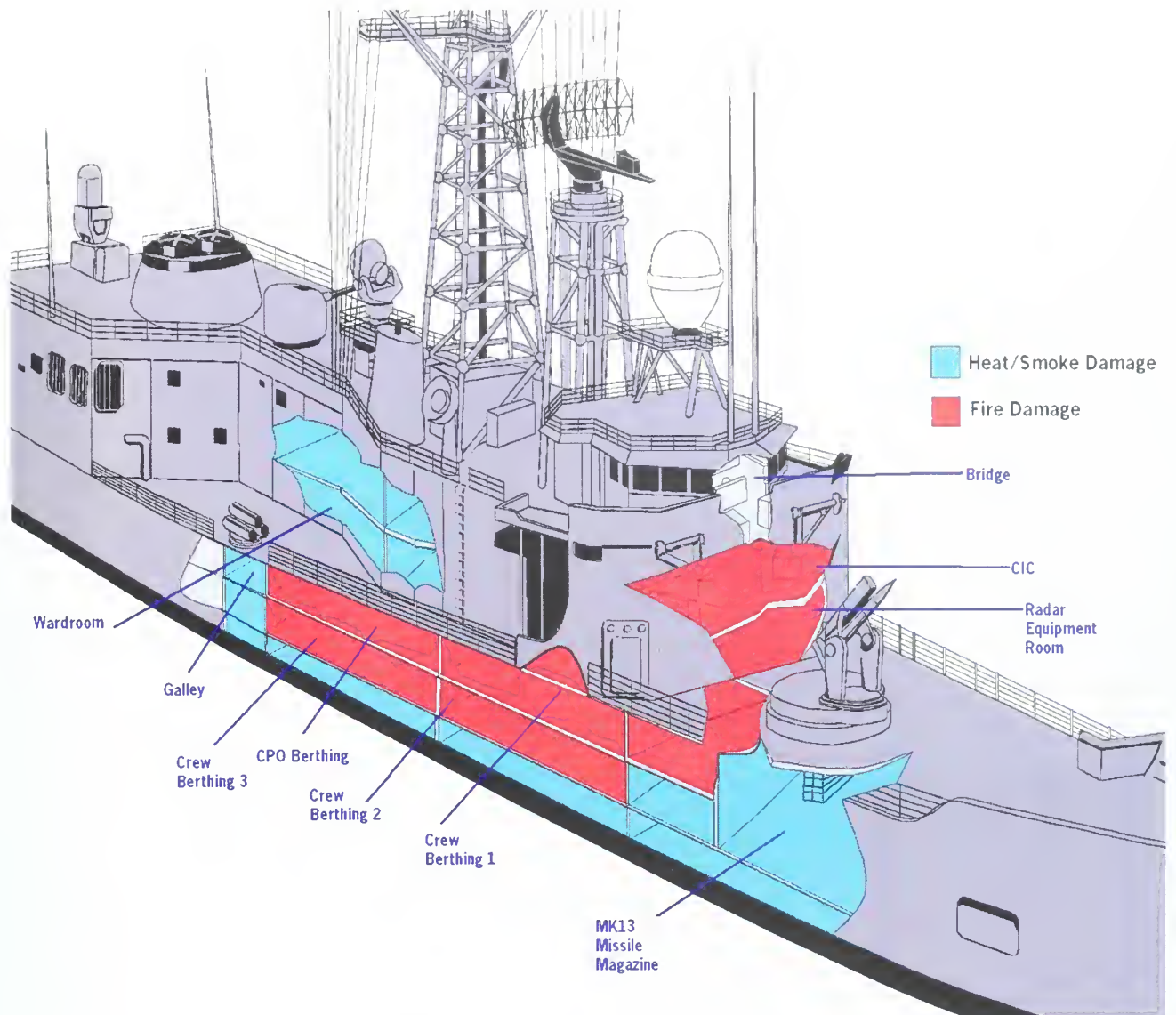

Figure 1 from Ref 2. USS STARK (FFG 31). Starboard Side Damage.



## **B. DESCRIPTION OF THE PROBLEM**

Modern technology today, allows computer simulation to enhance engineering research and development. In U.S. Naval applications, computer simulation modeling of fire and smoke propagation in current shipboard spaces would facilitate plans of action in damage control, and future ships could be designed space by space for maximum safety in fire and smoke protection. These computer modeled ship spaces could designate where fire fighting and life saving equipment should be placed for easy access in case of an emergency.

Most spaces aboard a ship are designed for maximum use of the equipment and machinery that are designated to that space. Equipment and machinery in a space become obstacles or fuel for a fire during a blaze where heavy and toxic smoke is present. During a damage control assessment of how to attack a fire, knowing how the smoke will propagate in a space will enhance the Damage Control Assistant's decisions of how his repair parties will combat a fire. As desktop personal computer speed and memory increases every year, the capability of predicting smoke propagation for every space in a ship is not far off in the future.

Each new class of ship becomes more technologically advanced, thus less personnel are needed to man it. It is planned that only 95 personnel will safely and efficiently operate the Surface Combatant of the 21<sup>st</sup> Century (DD 21).

Improvements in design can contribute significantly in obvious ways by reducing both the susceptibility and the survivability of platforms before an attack occurs. However, the benefits of applying technology to the reactive effort following a successful enemy attack, are hard to quantify. ... there are a number of damage control experts who doubt that technology can contribute to DC so comprehensively. They argue the impossibility of being able to predict the location or degree of damage and

that the path to increased survivability lies in the direction of adequate manpower and better platform design. [Ref 3]

With a small number of the crew to man fire parties, it is essential that knowledge of fire, heat, and smoke propagation in ship spaces is readily available to all personnel. The results of this study could offer future design engineers the data on how fire generated smoke propagates in shipboard space geometry and how the solid interferences within the space will affect it.

### **C. PREVIOUS WORK**

Jones and Walton [Ref 4] took their knowledge from their study of fire and smoke propagation in buildings and applied them to ships. Their methodologies were developed for civilian structures, so algorithms for stairways and elevators were changed for hatches, scuttles, and ladders. At the David W. Taylor Naval Ship Research and Development Center (DTNSRDC), they simulated a scenario where a 1-megawatt fire was located on the front starboard locker and berthing space. Zone modeling was used for this study. The simulated fire was caused by a missile hit and the burning of unspent solid propellant. These simulations were run in 1983 and were evaluated with limited processor speed and software. They determined that model simulations that had been developed for predicting fire and smoke propagation in buildings were similar in ships.

In 1985 Jones [Ref 5] studied fire and smoke propagation in multi-compartmental spaces implementing 2 computer programs. The BUILD software program was used to generate the model configuration, and the FAST software program was used to run fire scenarios in the model. Scenarios were run to emulate previous experiments of actual fires in multi-compartmental spaces. The results from the FAST program were to be



compared to the experimental data. In previous research, Jones noted that two or more layers of gases formed in a compartment. He again used zone modeling and modeled each compartment with composition of gas layer control volumes.

In this context, the predictive equations for the gas layers in each compartment result in from conservation of mass, momentum, and energy together with an equation of state for each compartment.[Ref 5]

Again limited by processor speed and memory size, Jones found disparity between actual experimental data and computer simulated data. After running simulations, he found his predicted temperatures were too high and gas layer depths were too small.

In 1992, Forney and Jones [Ref 6] with faster processor speed and improved software program CFAST, improved on modeling smoke movement through compartmented spaces. They successfully presented the radiative and convective heat balance terms which affected smoke flow through buildings. Their work emphasized the movement in a space of toxic gases that are generated in a fire. Their predictions of radiative and convective heat balances were favorable with experimental data.

In 1993, Forney and Jones [Ref 7] further improved their smoke transport model from previous work. Using the CFAST software program and a faster processor, they modeled the movement of toxic gases from the space of origin to a distant compartment. They also studied smoke transport with vertical flow and with mechanical ventilation. Refining the radiation transport scheme which affected energy distribution and buoyancy forces, their improved model generated data consistent with their experimental data.

Tatem and Williams [Ref 8] used the software program FAST and modeled missile propellant fires in shipboard compartments. They conducted a series of

experimental tests of burning propellant in a steel mock-up of shipboard compartments at China Lake. An algorithm for the burning rate of the missile propellant was developed in FAST, and after each experimental test, they ran their computer simulated model. The China Lake simulated test results underpredicted peak temperatures and overpredicted heat fluxes. In a second experimental test series, missile propellant was ignited aboard an ex-LEANDER Class Royal Navy frigate. In these series of simulated test runs, the predicted peak temperatures were in agreement with the experimental data, but again heat fluxes were overpredicted.

Mehls [Ref 9] used a commercial code CFD-ACE generated by Computational Fluid Dynamics Research Corporation (CFDRC). He modeled smoke propagation in a compartment aboard an Arleigh Burke (DDG 51) Class destroyer. Using his model and scenarios run, he was able to predict the temperatures of the mixture of smoke and cool air and how smoke propagates within a shipboard compartment. His model did not include any geometric interferences.

## **D. OBJECTIVES**

The purpose of this study is to develop and examine a computationally generated model that can predict how smoke travels in shipboard spaces that contain geometric interferences. The model will be generated in the form of compartment 01-163-2-L, aboard an Arleigh Burke (DDG-51) class destroyer. The geometrical interference will be in form of a ladder with a ladderback installed. Physical properties associated with the smoke such as density will be simulated.

## II. COMPUTATIONAL FLUID DYNAMICS

### A. OVERVIEW

Computational Fluid Dynamics (CFD) software is an invaluable tool for design optimization and rapid virtual prototyping for fluid transport problems. CFD computer simulations eliminate "trial and error" engineering and hasten the development of the fluid transport design and application. The commercial software package that was used in this research is called Computational Fluid Dynamics-Advanced Computing Environment (CFD-ACE) Version 6.2 [Ref 10-13] and was developed by the Computational Fluid Dynamics Research Corporation (CFDRC).

CFD-ACE is an integrated package comprised of three separate, yet interactive codes to solve the fluid transport problem [Figure 2]. The three codes are GEOM, GUI and VIEW. CFD-GEOM is the processor where a model can be created from scratch, or the model can be imported from another CAD program. CFD-GEOM offers comprehensive mesh generation, enabling the user to generate structured, unstructured, and mixed element meshes to represent the structure of the fluid transport problem. CFD-GUI (Graphic User Interface) is the solver for the package. The CFD-GEOM meshed model is imported into CFD-GUI. In CFD-GUI, scenarios for the fluid transport problem are created. Scenario parameters are set by the user. After fluid properties, initial and boundary conditions, and interaction of species (heat transfer, turbulence, mixing) are set, the user designates the number of iterations to run. The conservation equation solutions for the model are affected by the chosen differencing scheme and by varying the amount of relaxation and constraints. During the run, CFD-GUI solves the series of equations for all the inputted parameters. After the run in CFD-GUI, the solved

data is imported into CFD-VIEW. CFD-VIEW graphically illustrated the results in 2-D or 3-D.

## **B. FINITE VOLUME ANALYSIS**

The first step in the CFD analysis is to construct a geometric model over which the relevant fluid transport equations can be numerically integrated. The model creation is called domain modeling. CFD-ACE employs a structured, multi-domain, body fitted coordinated system approach which enables the user to simulate flows in complex geometric configurations. The fluid flow domain is gridded and divided into a number of cells known as control volumes.

A control volume is similar to a cube with six faces and six direct neighbors [Figure 3]. In the finite volume approach, discretized equations are formulated by evaluating and integrating fluxes across the faces of each control volume. This satisfies the relevant conservation equations. Dependent variables are solved for at the center of the control volume. The values obtained are considered to prevail over the entire control volume. Differencing schemes of varying accuracy can be used when evaluating convective fluxes over the control volume. These schemes can be independently selected for each fluid transport variable to be solved.

In CFD-ACE, fluid flows are simulated by numerically solving partial differential equations (PDE's) that govern the fluid transport variables. The mass, momentum, energy, turbulence quantities, mixture fractions, species concentrations, and radiative heat fluxes that will be solved will depend on the nature of the flow problem. The PDE's are discretized on a computational grid. A set of algebraic equations are formed and

solved. This numerical method yields a discrete solution of the flow field. The flow field is comprised of the values of the fluid transport variables at the grid points.

CFD-ACE uses an iterative solution method where equation sets for each fluid transport variable are solved in sequence until a converged solution is obtained. In CFD-ACE, the SIMPLEC algorithm is used [Figure 4]. The user implements the number of iterations (NITER) and in the case of transient simulation, the number of continuity iterations (C\_ITER) to be run. NITER and C\_ITER are dictated by the overall residual reduction obtained. At each iteration, CFD-ACE will calculate a residual for each fluid transport variable for all control volume cells. A reduction of five orders of magnitude in the residuals is needed before convergence is accepted.

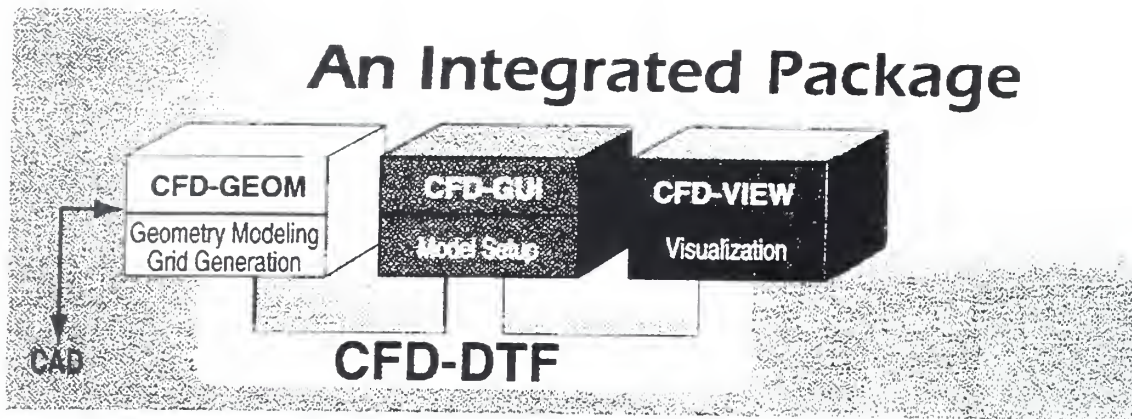

Figure 2 from [Ref. 14].

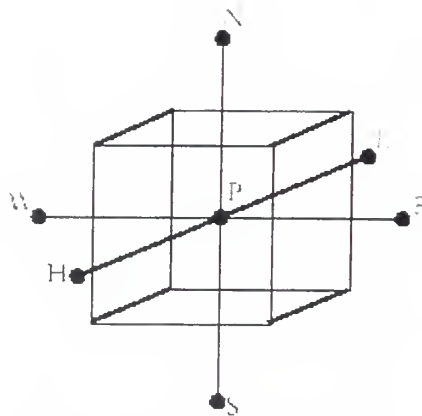

Figure 3 from [Ref. 10].

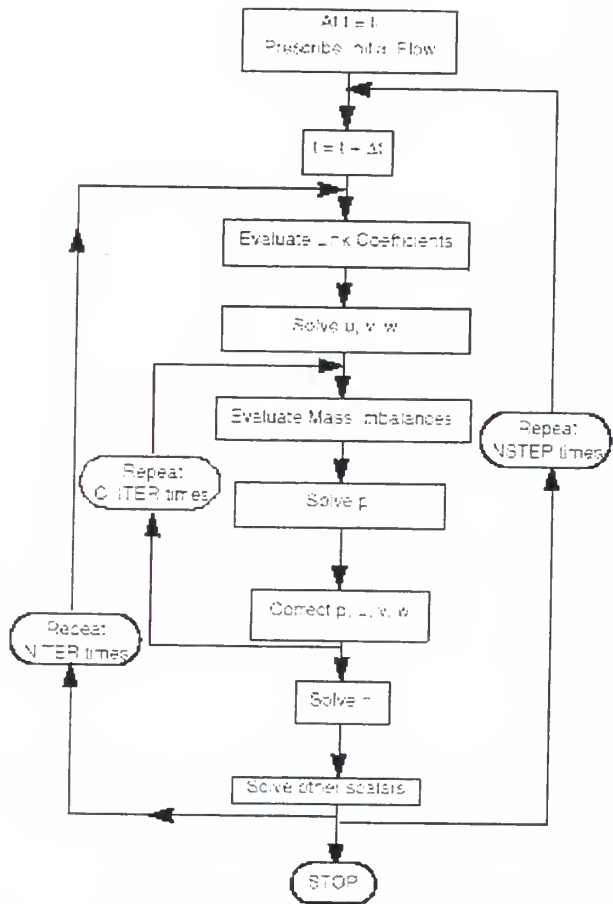

Figure 4 from [Ref. 10].



### III. MODEL

#### A. GEOMETRY

The creation and simulations of the model were carried out using a Micron Client Pro Desktop computer, with 384 megabytes of RAM and an internal 12 gigabyte hard drive. The software used was CFD-ACE+ version 6.2, which was last updated in July 2000.

A test box model of a shipboard ladder with an installed ladderback was modeled inside an 8m (length) by 8m (depth) by 2.29m (height) box. The dimensions of the ladder were identical to shipboard specifications. Figure 5 is a skeletal view of the ladder inside the test box. Due to the simple locations of the ladder and watertight doors in the test box, a structured grid was used on the model. Using the structured grid, 14 control volumes were created. The ladder was comprised of three solid control volumes, and the remainder 11 control volumes were made of air.

A model of passageway 01-163-2-L aboard an Arleigh Burke Class Destroyer (DDG-21) was designed. The dimensions of the model and ladder identically match the actual compartment. A shipboard plan view of the compartment from a ship's drawing is shown in Figure 6. This compartment has a variety of openings for smoke intrusion and will allow an assortment of smoke propagation scenarios to be studied. CFD-ACE has the capability for any entrance or exit in the model, when not part of the scenario, to be designated as a wall. Therefore, the non-activated entrances and exits have no effect on the results of the scenario. Using the exact dimensions and locations of the ladder, hatches, and watertight doors, a problem arose with the creation and orientation of the control volumes in the space. To remedy the situation, an unstructured grid was used on

the compartment. The unstructured grid allowed the ladder to be made up three solid control volumes and the entire space to be made up of a control volume of air.

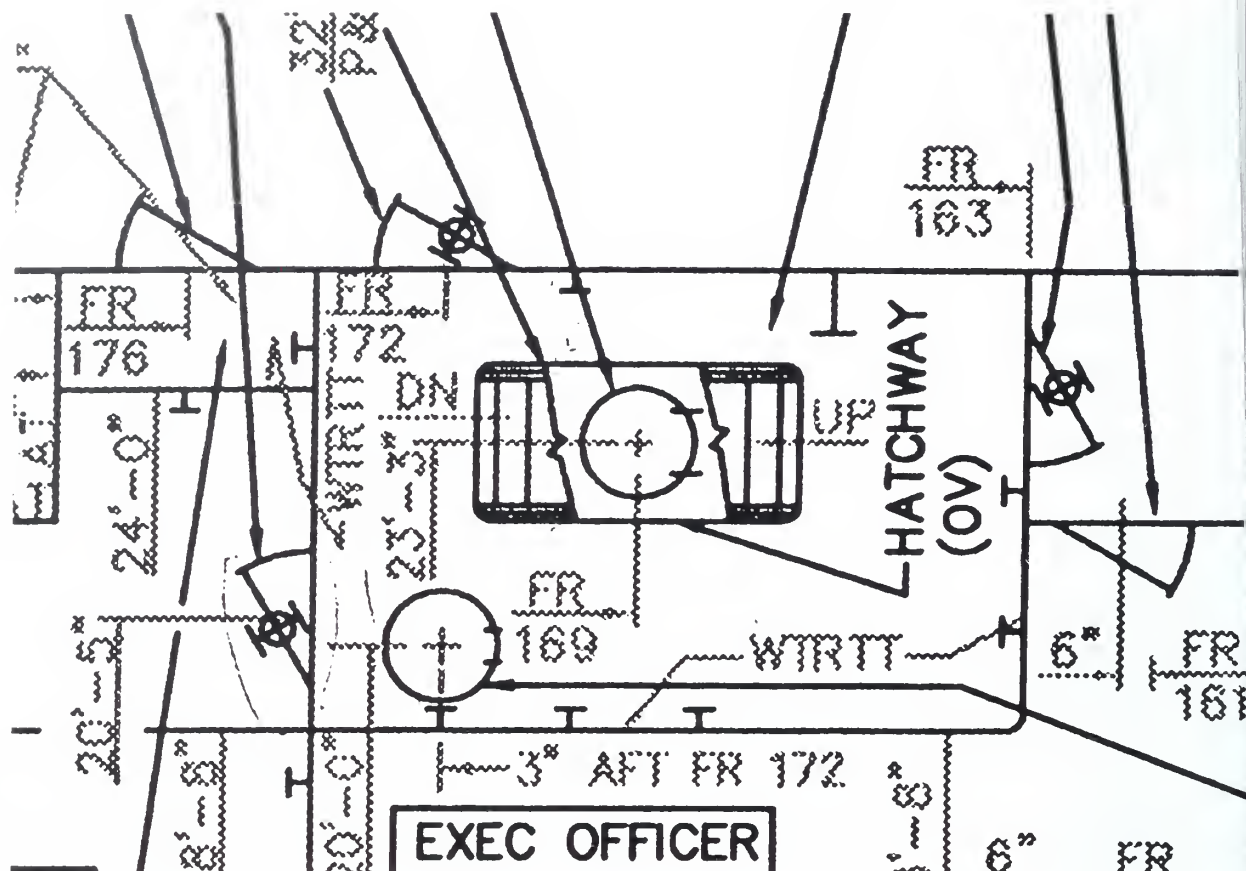
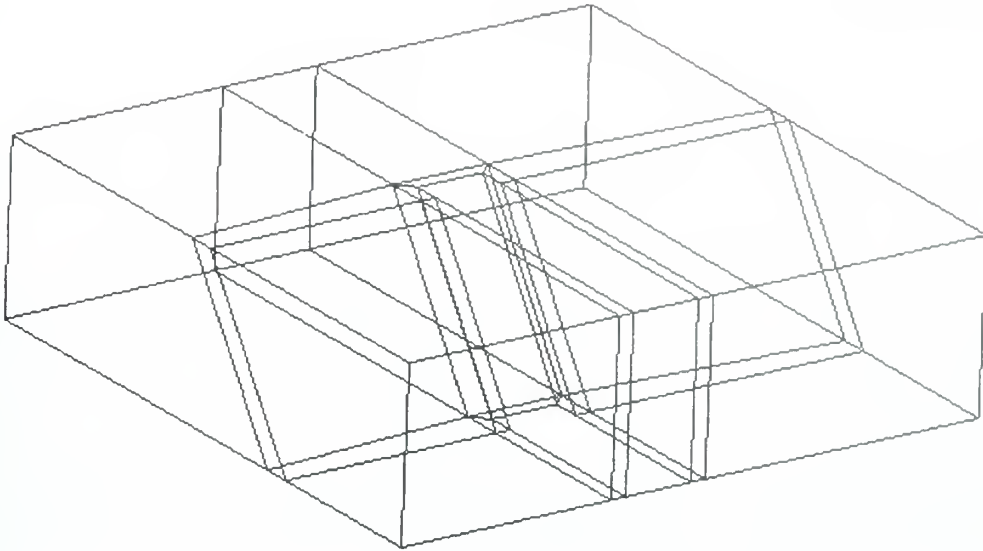

Figure 5. Plan View of Space 01-163-2-L

## B. GRID GENERATION

In CFD-GEOM, a succession of steps must be followed when generating a structured or an unstructured grid on a model. For both types of grids a skeletal model must be created as shown in Figure 7-8. Both rough skeletal models are made up of geometric lines in the line generation tools in CFD-GEOM. Both skeletal models show





**Figure 6. Skeletal structure of test box**

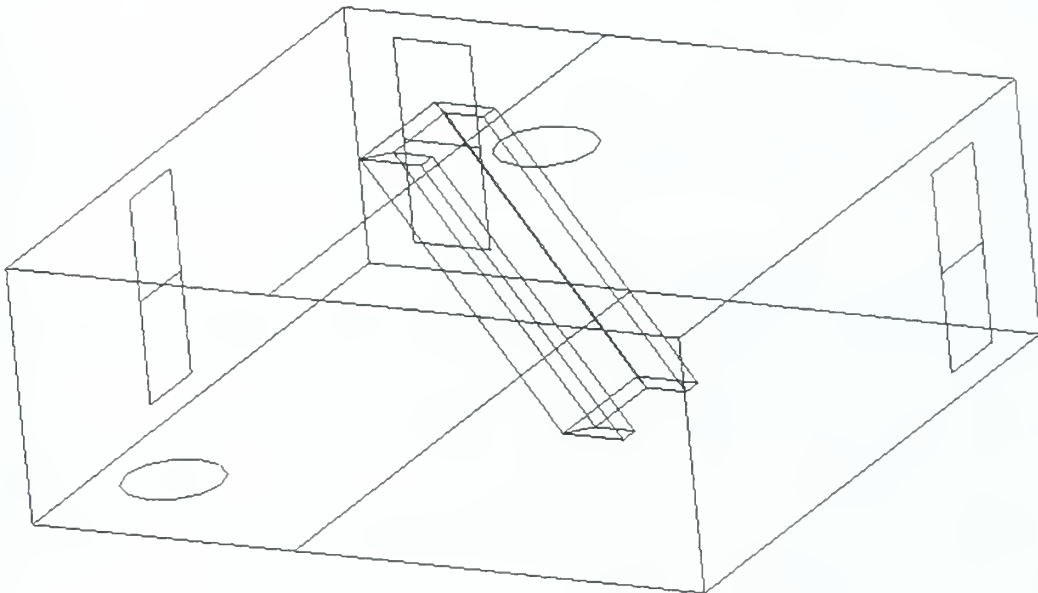

**Figure 7. Skeletal structure of Compartment 01-163-2-L**

the large rectangular outer structure made up of the space, ladder, hatches, and watertight doors.

For structured grid generation, edges must be placed on the lines that make up the model. CFD-GEOM will place a number of grid points inputted by the user on these created edges. A structured grid face is then created from a closed polygon that is made up from the selection of four edges. Each edge opposite of another edge must have the same number of grid points in order for the face to be made. For a circle, edges are represented by 4 arcs with an equal number of grid points for each arc. These arcs can then be picked to make up a grid face.

For an unstructured grid generation, edges do not have to be created and put on the lines that make up the model. A rough surface is first placed on the polygon face where an unstructured grid is needed. A trimming loop is then placed on the outline of the polygon face. The user then must select the created rough surface to be trimmed and then select the trimming loop. CFD-GEOM then will trim the rough surface in the shape of the loop that was placed on the polygon face. This is a trimmed loop surface. The user then must create trimmed loop surfaces on each polygon face of the model until the entire model is made up of trimmed loop surfaces. After the model is made up of trimmed loop surfaces, a closed surface set can be made for the model. The user selects the 'create closed surface set' icon in the topology section in CFD-GEOM. Each trimmed loop surface must be selected. After all trimmed loop surfaces are selected, the user must input the selection. The closed surface set is then created. To create the unstructured grid surface, the 'triangular grid' icon must be selected from the grid section in CFD-GEOM. The user then will select and input the created closed surface set. An unstructured grid

surface is then generated on the model. Rough surfaces and trimming loops can easily put on circles to make trimmed loop surfaces to be picked to generate unstructured grids.

### **C. VOLUME GENERATION**

In a structured grid, 6 structured grid faces must be created to make up a volume block. To make a volume block, the user must select the 'create a block' icon in the grid section in CFD-GEOM. The user will be prompted to select 6 grid faces. Once the faces are selected and inputted, the volume block is created. Various volume boxes make up a volume of a model. Opposite faces must have the same number of grid points in order for the structured volume block to be generated.

In an unstructured grid, volume cells for the model are created by first selecting the 'create volume set' icon in the topology section in CFD-GEOM. The user will be prompted to pick the closed surface set that were made while creating the unstructured grid. Once the closed surface set is selected and inputted, the volume set for the model is generated. The user then must then create tetrahedral cells for the volume. The tetrahedral icon in the grid section is then selected. The user will be prompted to select the volume set. Once the volume set has been selected and inputted, the volume cells in the model are created.

### **D. MODEL CONFIGURATION**

The test box model shown in Figure 9 was made up of 98,224 structured grid cells, 50 grid faces, and 14 volume boxes. The compartment model shown in Figure 10 was made up of 298,424 unstructured tetrahedral volume cells.



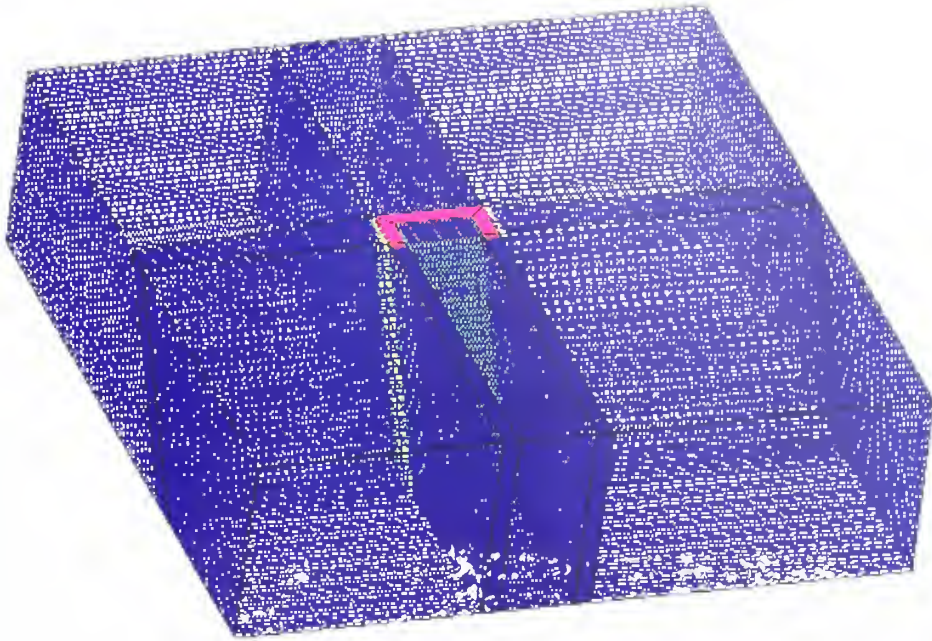

Figure 8. Test model with structured grids.

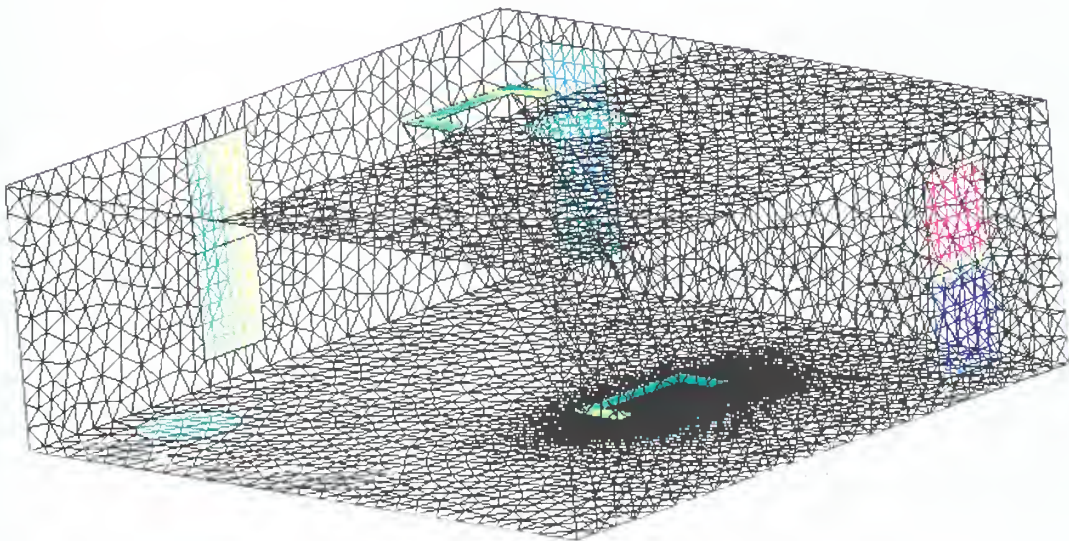
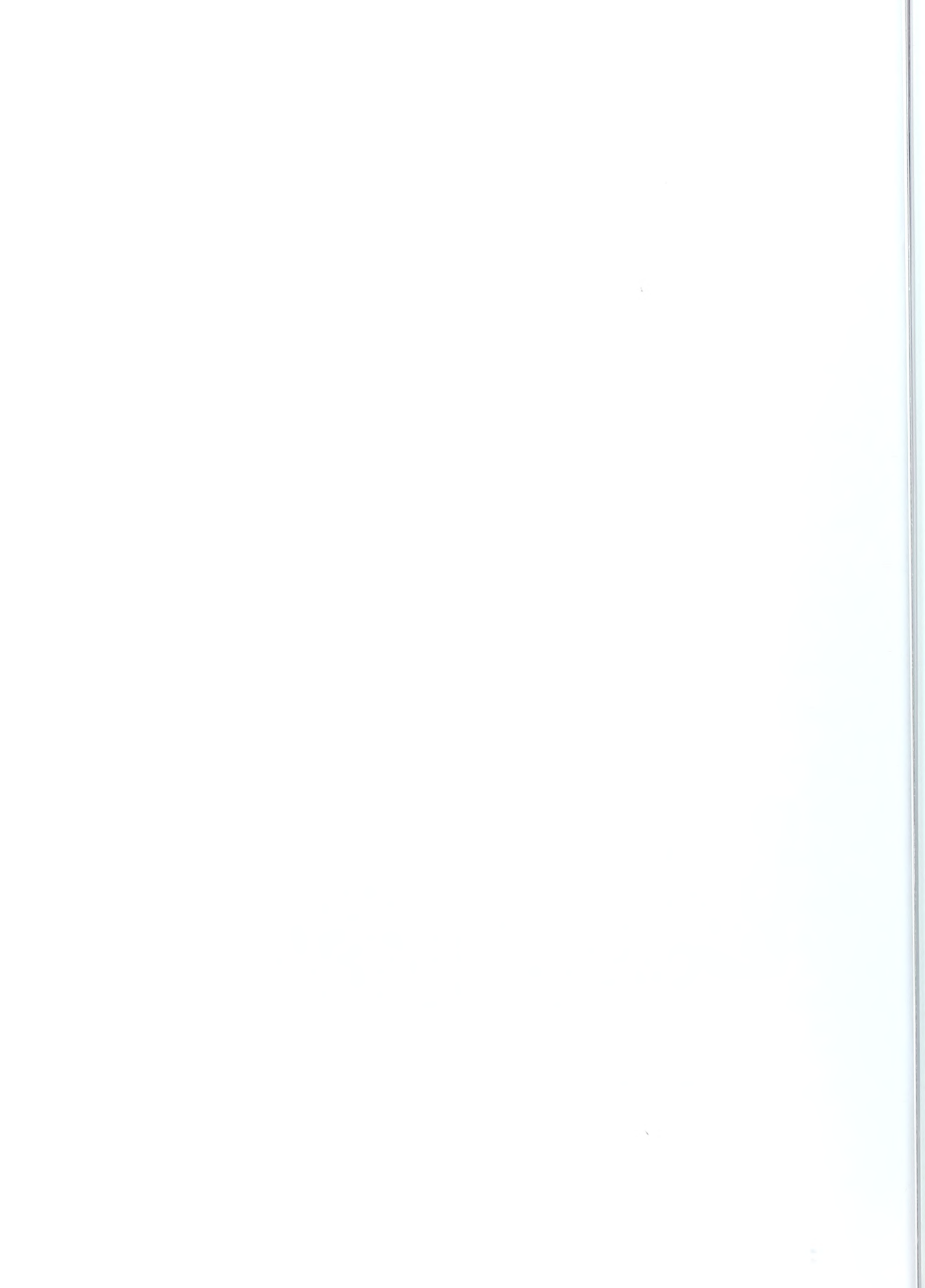

Figure 9. Model of compartment 01-163-2-L with unstructured grid.





## IV. RESULTS

The objective of this research was to use the CFD-ACE program to see how a geometric interference in a shipboard compartment affects smoke propagation. Three scenarios were run in the generated model. Each scenario was run in steady state. All inputs for each scenario are shown in appendices.

Scenario A was used to qualitatively evaluate how geometric interferences designed in a space can modify fluid flow. 500K air was set to enter the space through the forward door and exit the aft door. Figures 10 and 11 display isotherms being diverted about the ladder. Figure 12 shows the diverted isotherm engulfing the ladder. The ladder has acted as a barrier and diverted the flow.

With the success of scenario A, scenario B was run to compare the results of Mehls' [Ref. 9] scenario A. Figures 13 and 14 display the isosurface smoke concentrations of 88% and 77% respectively. In Figure 14, the isosurface begins to be diverted up the ladder. Figure 15 and 16 compares isosurface smoke concentrations of 54% for scenario B and Mehls' scenario A. The scenario B isosurface has not propagated as far in the space as the isosurface in Mehls' Scenario B due to the ladder diverting the smoke. Figure 17, displays the isosurface smoke concentration of 40%. This isosurface has engulfed the ladder and is being diverted upward. The designed geometric interference has limited the propagation of smoke.

Scenario C was used to study the effects the ladder has on smoke that is entering the space vertically. The smoke enters the hatch located on the deck and exits the hatch located on the overhead. Figure 18 displays smoke entering the space and the isosurface is 99% smoke concentration. Figure 19 displays the isosurface smoke concentration of

80%. The back of the ladder has diverted the isosurface around it. In Figure 20, the isosurface smoke concentration of 54% engulfs the ladder and is again diverted upward. Smoke that enters vertically is also impeded by the designed geometric interference.

For each scenario, residual outputs decreased a magnitude of five orders. According to CFDRC's criteria of convergence, scenario results were validated.



## **V. CONCLUSIONS**

This study's results successfully modeled smoke propagation in a shipboard compartment with geometric interferences. Scenario accuracy results were validated and verified by the residual outputs.

This study verified that smoke propagation in a compartment is affected by the geometric interference. The ladder diverted the smoke thus slowing smoke propagation within the compartment.

THIS PAGE INTENTIONALLY LEFT BLANK

## VI. RECOMMENDATIONS

The following recommendations are made in continuation of this study:

- Model a heat source in the compartment and use CFD-ACE to analyze fire and smoke scenarios.
- Add adjoining compartment to analyze how fire and smoke propagation are affected by the ladder.
- Model the compartment with more complex geometric interferences in a CAD software program (e.g. IDEAS) and then import it into GEOM. This will allow for more complex geometries to be gridded with unstructured grids.
- Use transient time step calculations to calculate wall temperatures and rate of smoke propagation.

THIS PAGE INTENTIONALLY LEFT BLANK

## **APPENDIX A.**

Scenario A was developed as a test scenario to see if the designed ladder with a ladderback would effect fluid flow. The ladder was designed inside a 8m (length) by 8m (depth) by 2.29m (height) box. The front watertight door is the inlet and the back watertight door is the outlet. Refer to the next page for the required inputs.

<b>Relaxation</b>	Velocity	(m/s)	0.2
	Turbulence	(J)	0.0
	Enthalpy	(KJ/kg)	1.0
	Mixture Fractions		0.0
<b>Sweeps</b>	Velocity	(m/s)	5
	Pressure	(Pa)	30
<b>Initial Conditions</b>	U Velocity	(m/s)	-1
	V Velocity	(m/s)	0
	W Velocity	(m/s)	0
	Relative pressure	(Pa)	0
	Turbulence Kinetic Energy	(J)	0.00
	Rate of Turbulence Dissipation	(J/s)	0.00
	Turbulent Length Scale	(m)	0.00
	Temperature	(K)	500
	Gravity	(m/s <sup>2</sup> )	-9.81
	Reference Pressure	(Pa)	1E5
<b>Boundary Conditions</b>	Isothermal Wall Temperature	(K)	300
<b>Inlet - Air</b>	U Velocity	(m/s)	-5
	V Velocity	(m/s)	0
	W Velocity	(m/s)	0
	Temperature	(K)	500
	Turbulence Kinetic Energy	(J)	0.00
	Rate of Turbulence Dissipation	(J/s)	0.00
	Turbulence Length Scale	(m)	0.00
	Pressure	(Pa)	0
<b>Outlet</b>	U Velocity	(m/s)	0
	V Velocity	(m/s)	0
	W Velocity	(m/s)	0
	Temperature	(K)	300
	Turbulence Kinetic Energy	(J)	0.00
	Rate of Turbulence Dissipation	(J/s)	0.00
	Turbulence Length Scale	(m)	0.08
	Pressure	(Pa)	0

Table 1. Input data for Scenario A.

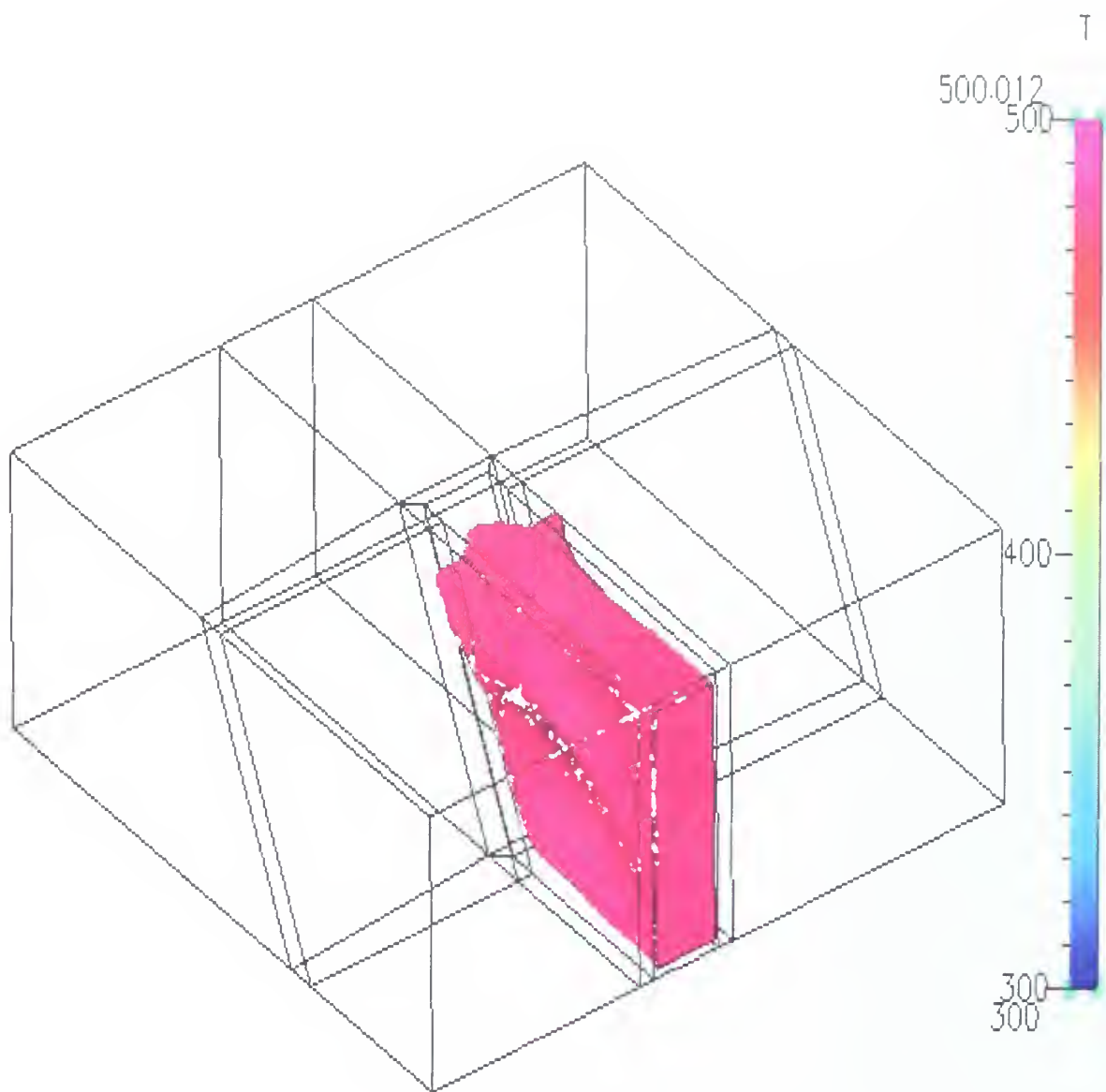
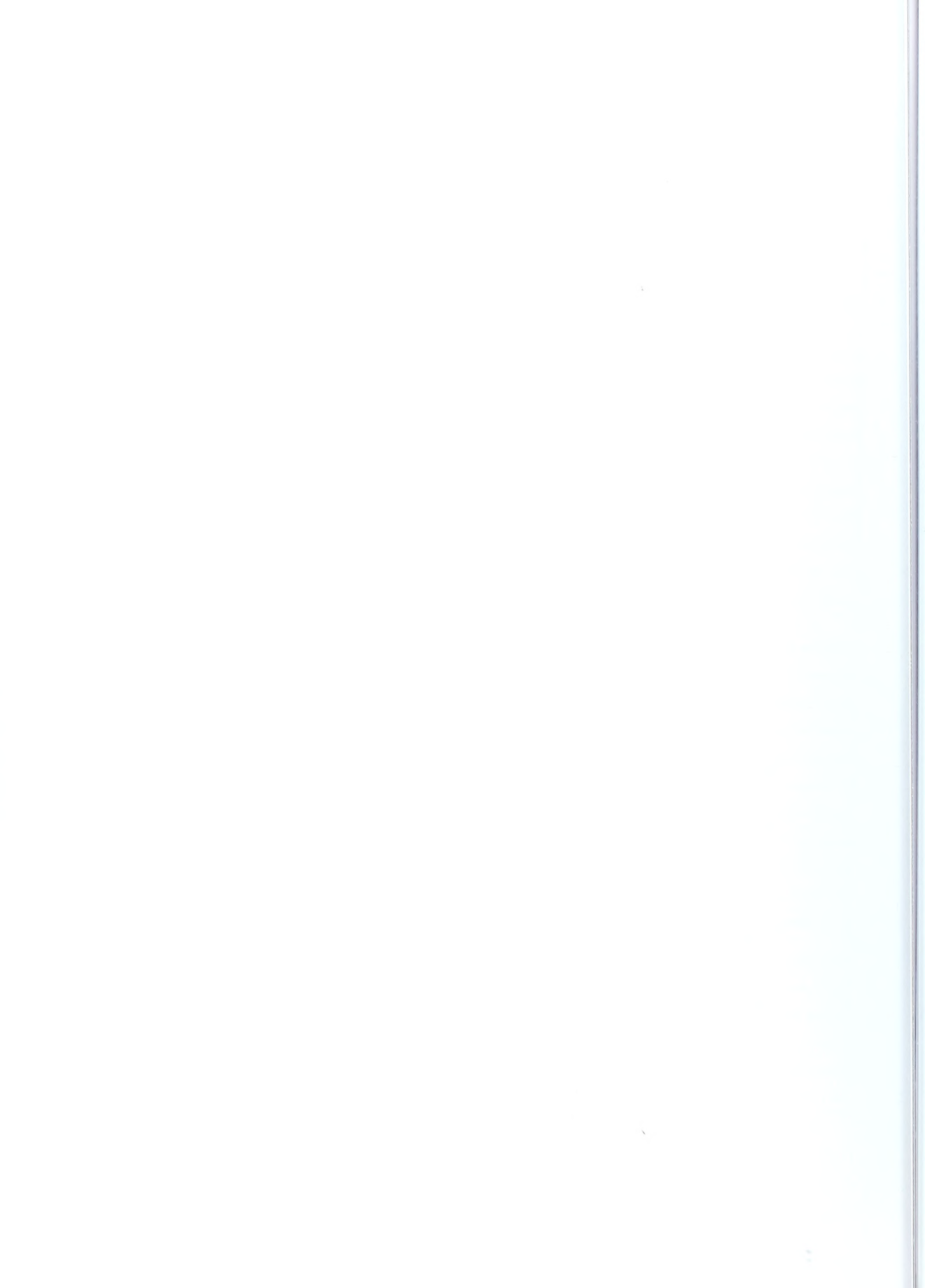

Figure 10. Isotherm first engaging ladder in Test Box.





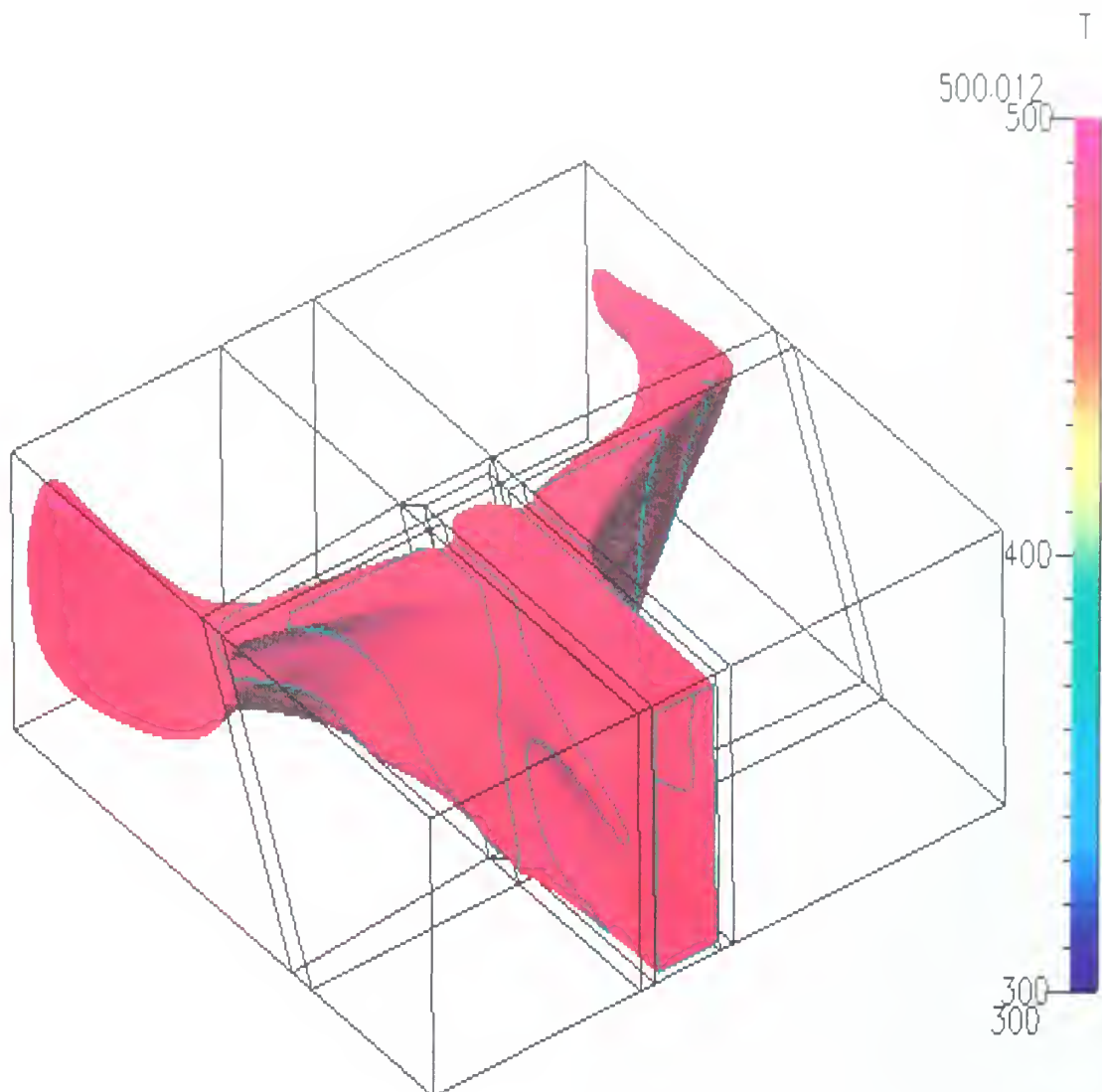

Figure 11. Isotherm diverted by ladder in Test Box.



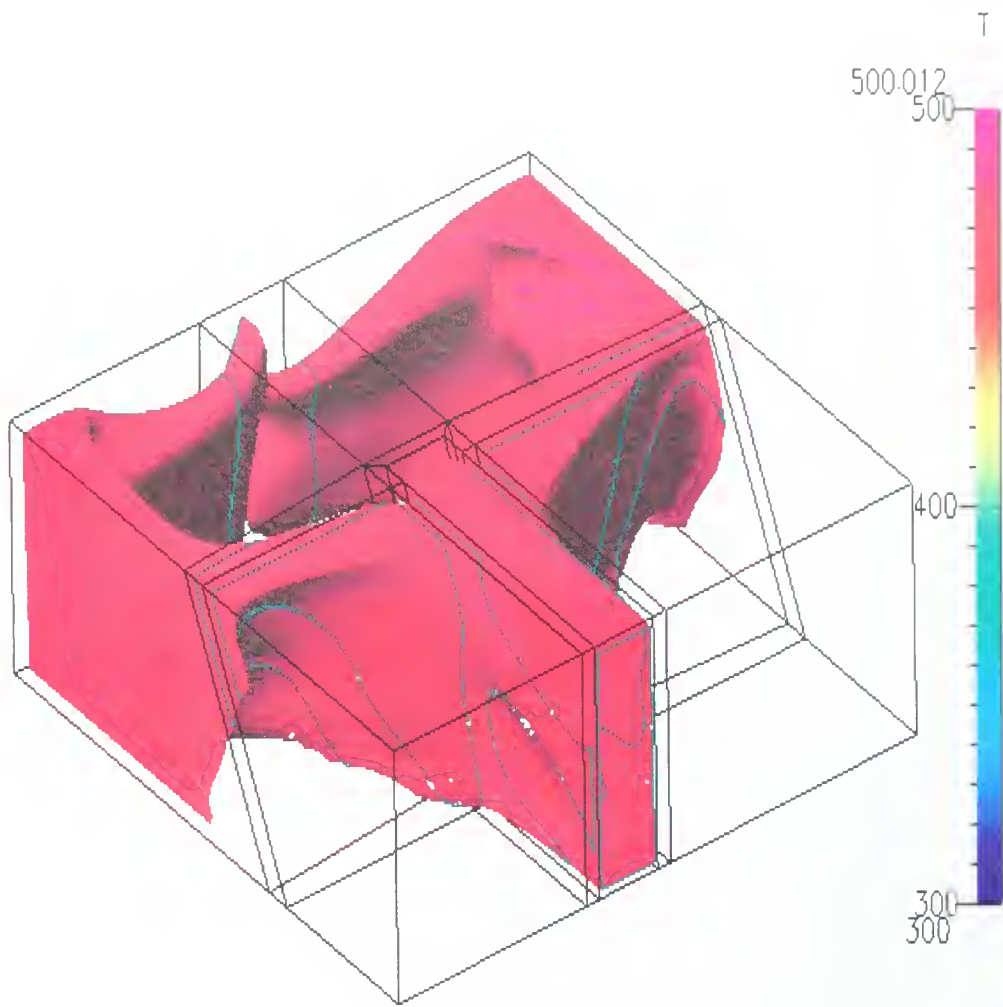

Figure 12. Isotherm surrounding ladder in Test Box.



THIS PAGE INTENTIONALLY LEFT BLANK



## **APPENDIX B.**

Scenario B was developed as a scenario comparable to Mehls [Ref 9] scenario A. The inlet is located at the front watertight door. The upper half of the door is designated as the smoke inlet. The lower half of the door is exclusively air. Refer to the next page for the required inputs.

<b>Relaxation</b>	Velocity	(m/s)	0.2
	Turbulence	(J)	1.0
	Enthalpy	(KJ/kg)	1.0
	Mixture Fractions		0.2
<b>Sweeps</b>	Velocity	(m/s)	5
	Pressure	(Pa)	30
<b>Initial Conditions</b>	U Velocity	(m/s)	-0.1
	V Velocity	(m/s)	0
	W Velocity	(m/s)	0
	Relative pressure	(Pa)	0
	Turbulence Kinetic Energy	(J)	0.04
	Rate of Turbulence Dissipation	(J/s)	-0.05
	Turbulent Length Scale	(m)	0.06
	Temperature	(K)	500
	Reference Pressure	(Pa)	1E5
<b>Boundary Conditions</b>	Isothermal Wall Temperature	(K)	300
<b>Inlet – Smoke</b>	U Velocity	(m/s)	-0.1
	V Velocity	(m/s)	0
	W Velocity	(m/s)	0
	Temperature	(K)	500
	Turbulence Kinetic Energy	(J)	0.
	Rate of Turbulence Dissipation	(J/s)	0.04
	Turbulence Length Scale	(m)	0.06
	Pressure	(Pa)	0
<b>Inlet - Air</b>	U Velocity	(m/s)	-0.1
	V Velocity	(m/s)	0
	W Velocity	(m/s)	0
	Temperature	(K)	500
	Turbulence Kinetic Energy	(J)	0.04
	Rate of Turbulence Dissipation	(J/s)	-0.05
	Turbulence Length Scale	(m)	0.06
	Pressure	(Pa)	0

Table 2. Input Data for Scenario B.



<b>Outlet</b>	U Velocity	(m/s)	0
	V Velocity	(m/s)	0
	W Velocity	(m/s)	0
	Temperature	(K)	400
	Turbulence Kinetic Energy	(J)	0.02
	Rate of Turbulence Dissipation	(J/s)	-0.05
	Turbulence Length Scale	(m)	0.08
	Pressure	(Pa)	0

**Table 2 Cont. Input Data for Scenario B.**

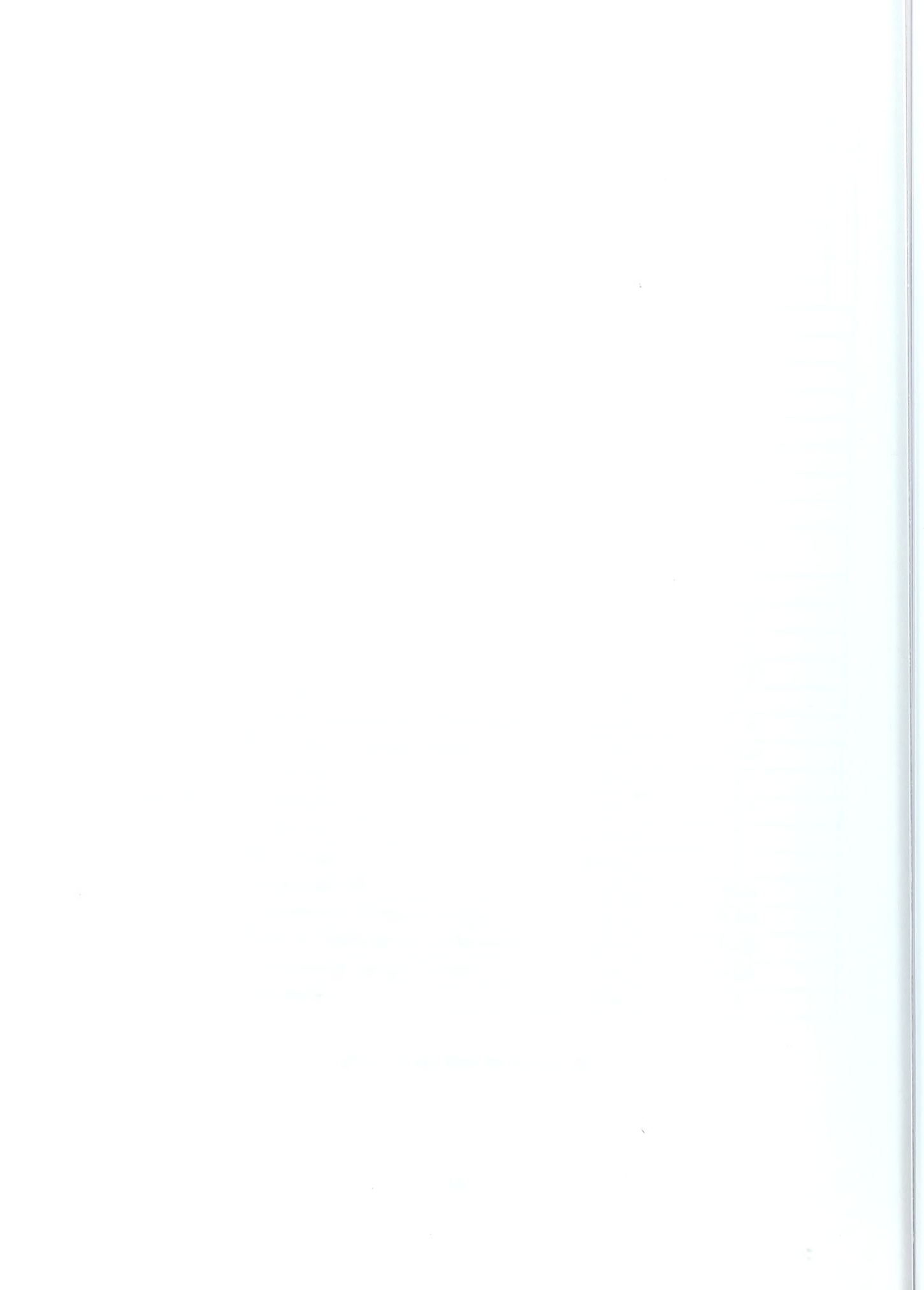

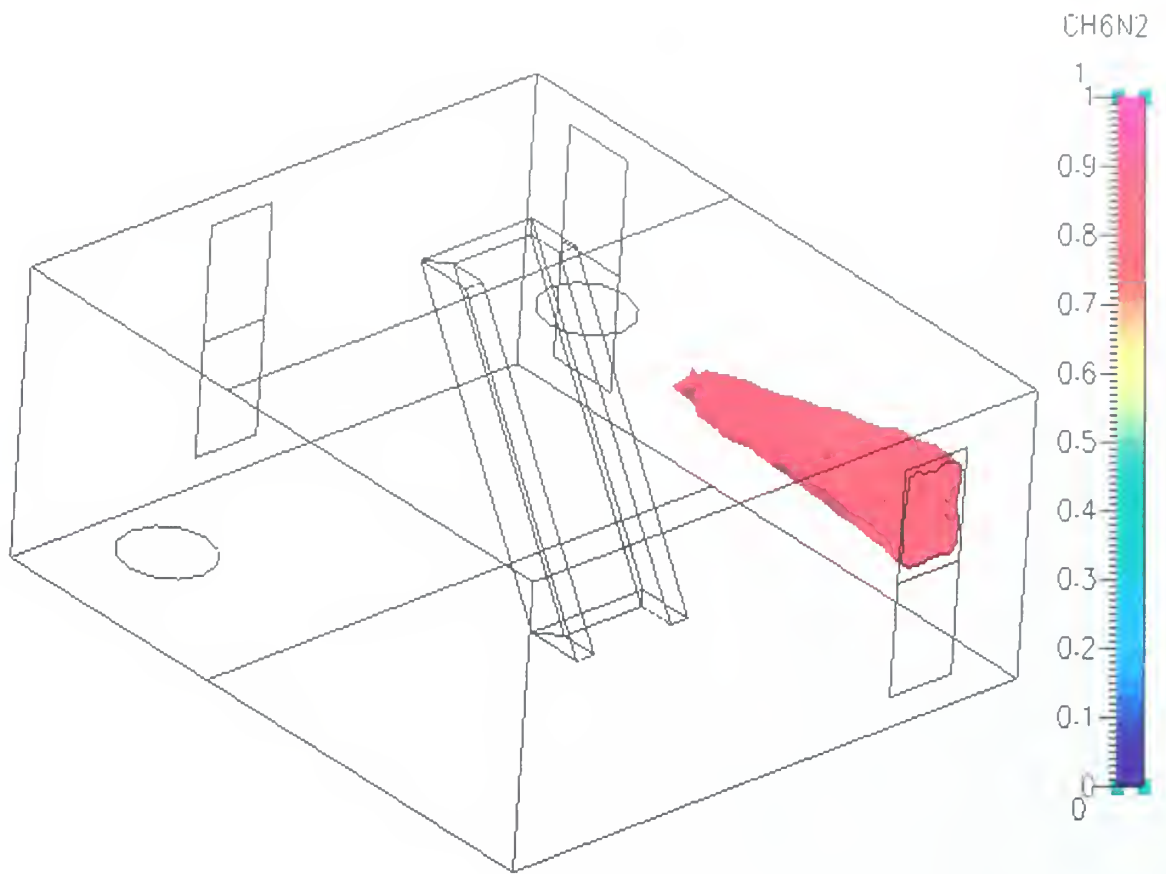

Figure 13. 88% Smoke Concentration in compartment 01-163-2-L.



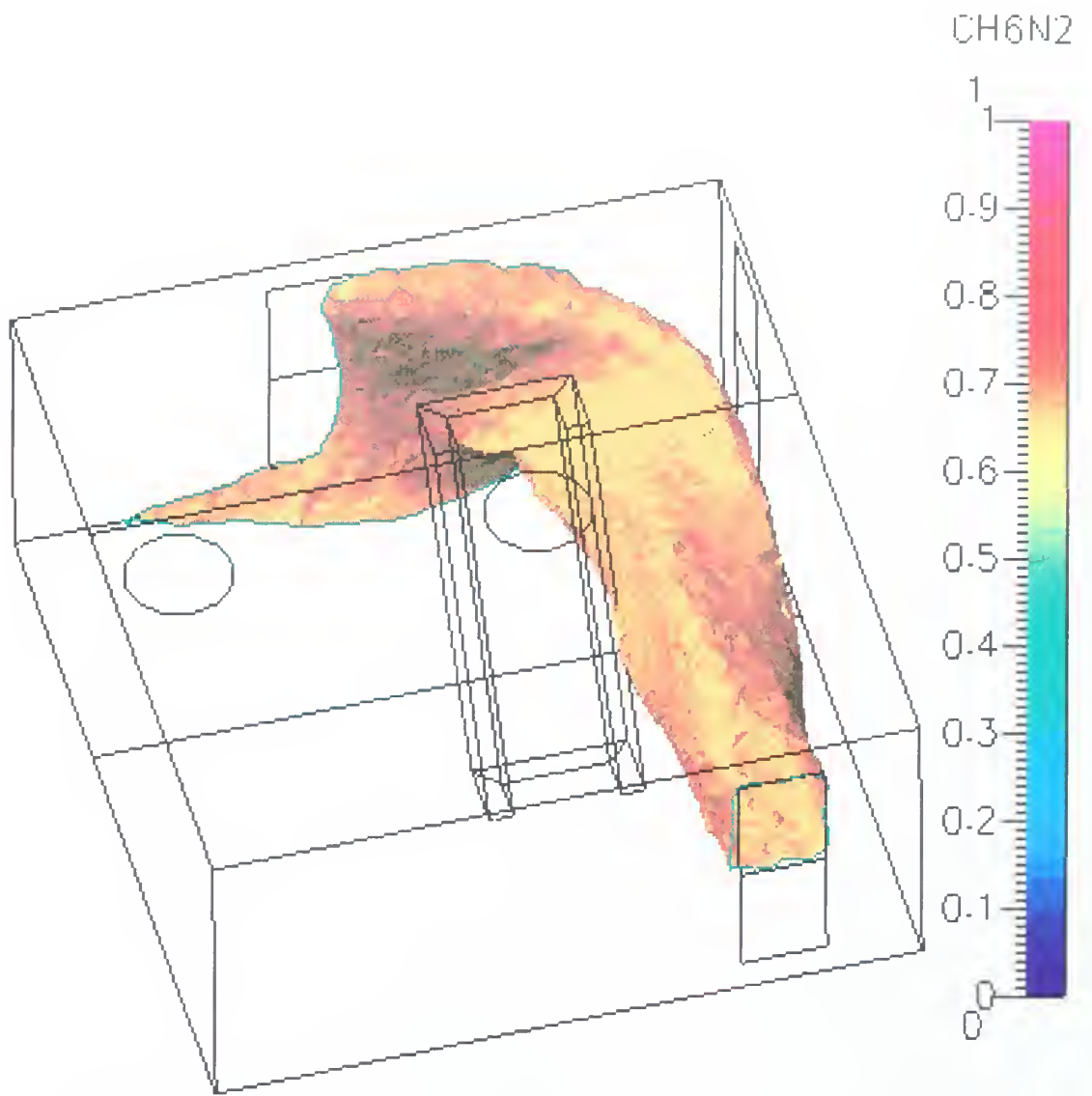

Figure 14. 72% Smoke Concentration in compartment 01-163-2-L.



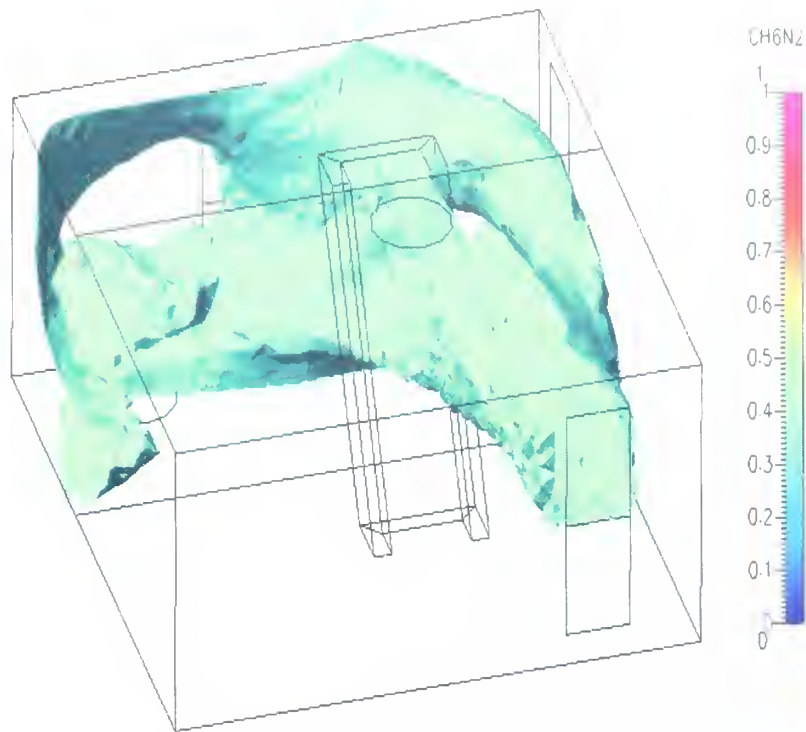

Figure 15. 54% Smoke Concentration in compartment 01-163-2-L.

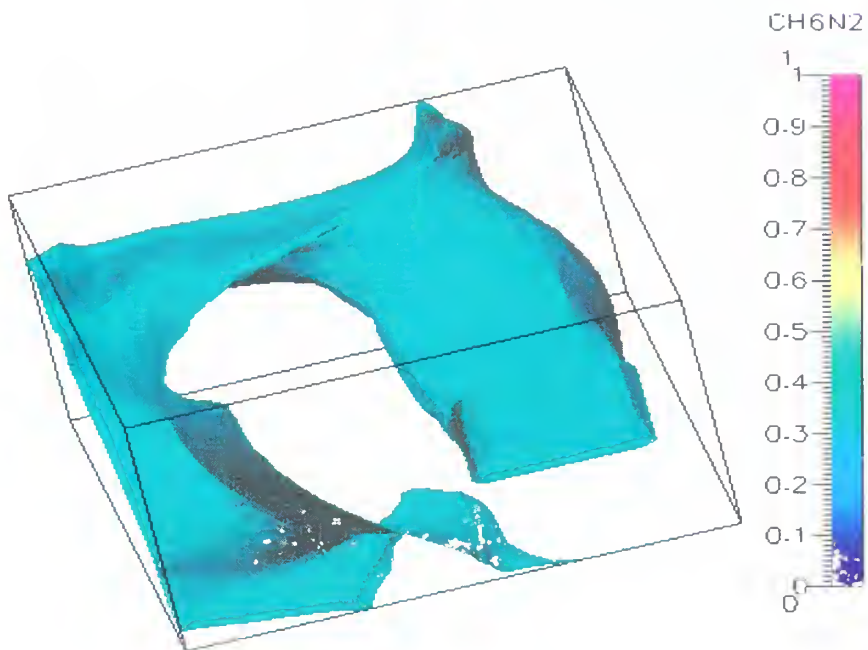

Figure 16. From Mehls [Ref.9] 54% Smoke Concentration in compartment 01-163-2-L.





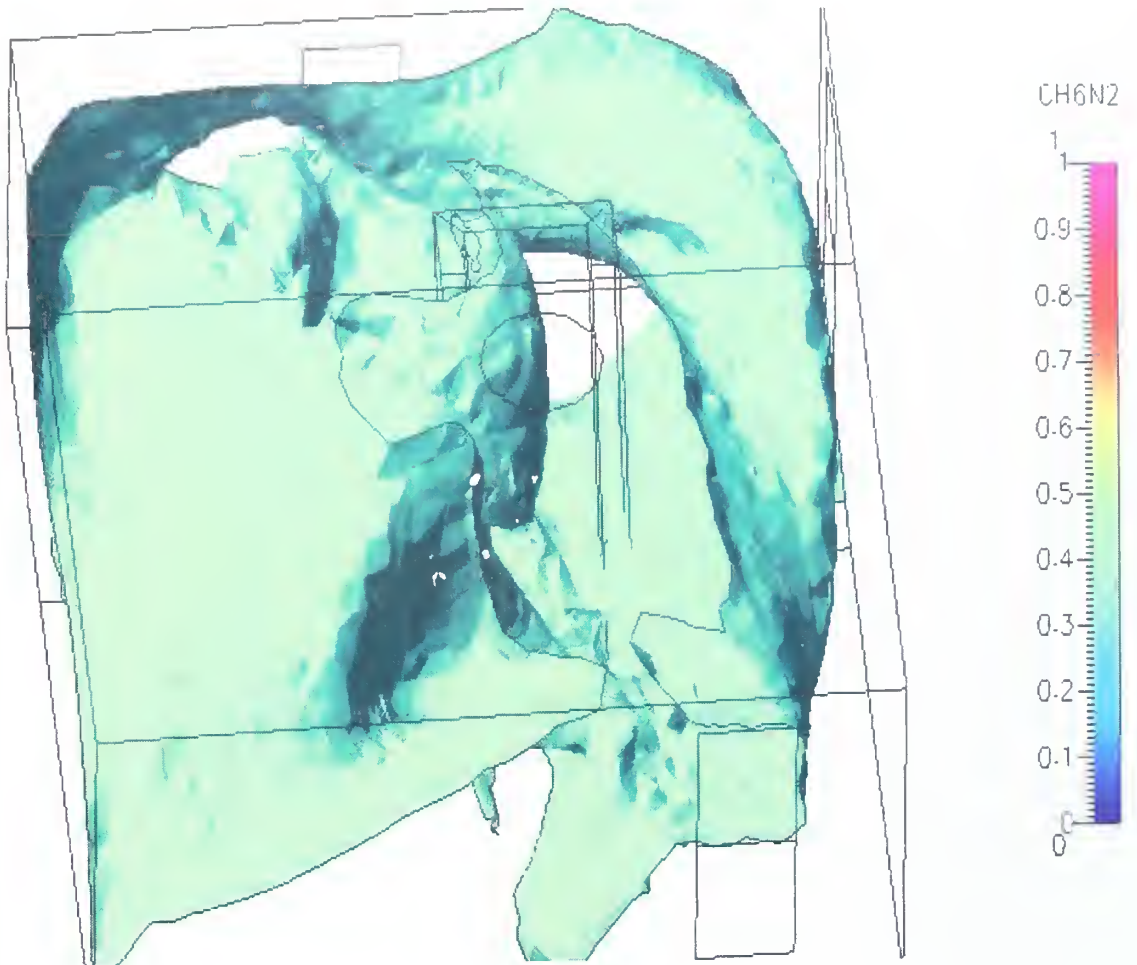

Figure 17. 40% Smoke Concentration in compartment 01-163-2-L.



THIS PAGE INTENTIONALLY LEFT BLANK



## APPENDIX C.

Scenario C was developed to study how the propagation of smoke in the vertical direction is affected by a geometric interference. The bottom scuttle is designated a smoke inlet while the top scuttle is designated a smoke outlet. All the watertight doors are designated as walls. Refer to the next page for the required inputs.

<b>Relaxation</b>	Velocity	(m/s)	0.2
	Turbulence	(J)	1.0
	Enthalpy	(KJ/kg)	1.0
	Mixture Fractions		0.2
<b>Sweeps</b>	Velocity	(m/s)	5
	Pressure	(Pa)	30
<b>Initial Conditions</b>	U Velocity	(m/s)	-0.1
	V Velocity	(m/s)	0
	W Velocity	(m/s)	-2
	Relative pressure	(Pa)	0
	Turbulence Kinetic Energy	(J)	0.04
	Rate of Turbulence Dissipation	(J/s)	-0.05
	Turbulent Length Scale	(m)	0.06
	Temperature	(K)	500
	Gravity	(m/s <sup>2</sup> )	-9.81
	Reference Pressure	(Pa)	1E5
	<b>Boundary Conditions</b>	Isothermal Wall Temperature	(K)
<b>Inlet – Smoke</b>	U Velocity	(m/s)	0
	V Velocity	(m/s)	5
	W Velocity	(m/s)	0
	Temperature	(K)	500
	Turbulence Kinetic Energy	(J)	0
	Rate of Turbulence Dissipation	(J/s)	0.04
	Turbulence Length Scale	(m)	0.06
	Pressure	(Pa)	0
<b>Inlet - Air</b>	U Velocity	(m/s)	0
	V Velocity	(m/s)	0
	W Velocity	(m/s)	0
	Temperature	(K)	0
	Turbulence Kinetic Energy	(J)	0.0
	Rate of Turbulence Dissipation	(J/s)	0.0
	Turbulence Length Scale	(m)	0.0
	Pressure	(Pa)	0

Table 3. Input Data for Scenario C.

<b>Outlet</b>	U Velocity	(m/s)	0
	V Velocity	(m/s)	.2
	W Velocity	(m/s)	0
	Temperature	(K)	300
	Turbulence Kinetic Energy	(J)	0.02
	Rate of Turbulence Dissipation	(J/s)	-0.05
	Turbulence Length Scale	(m)	0.08
	Pressure	(Pa)	0

**Table 3 Cont. Input Data for Scenario C.**

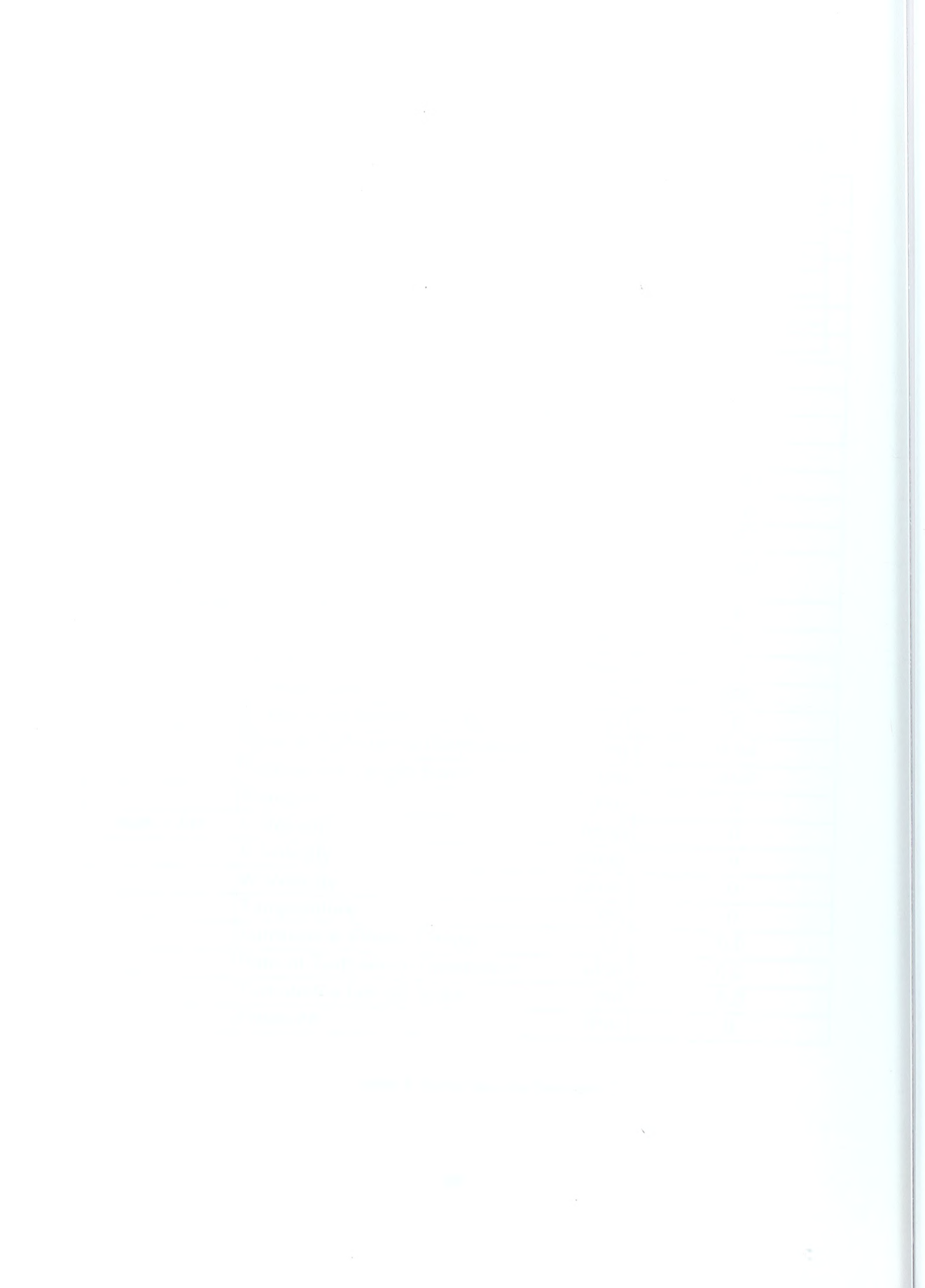



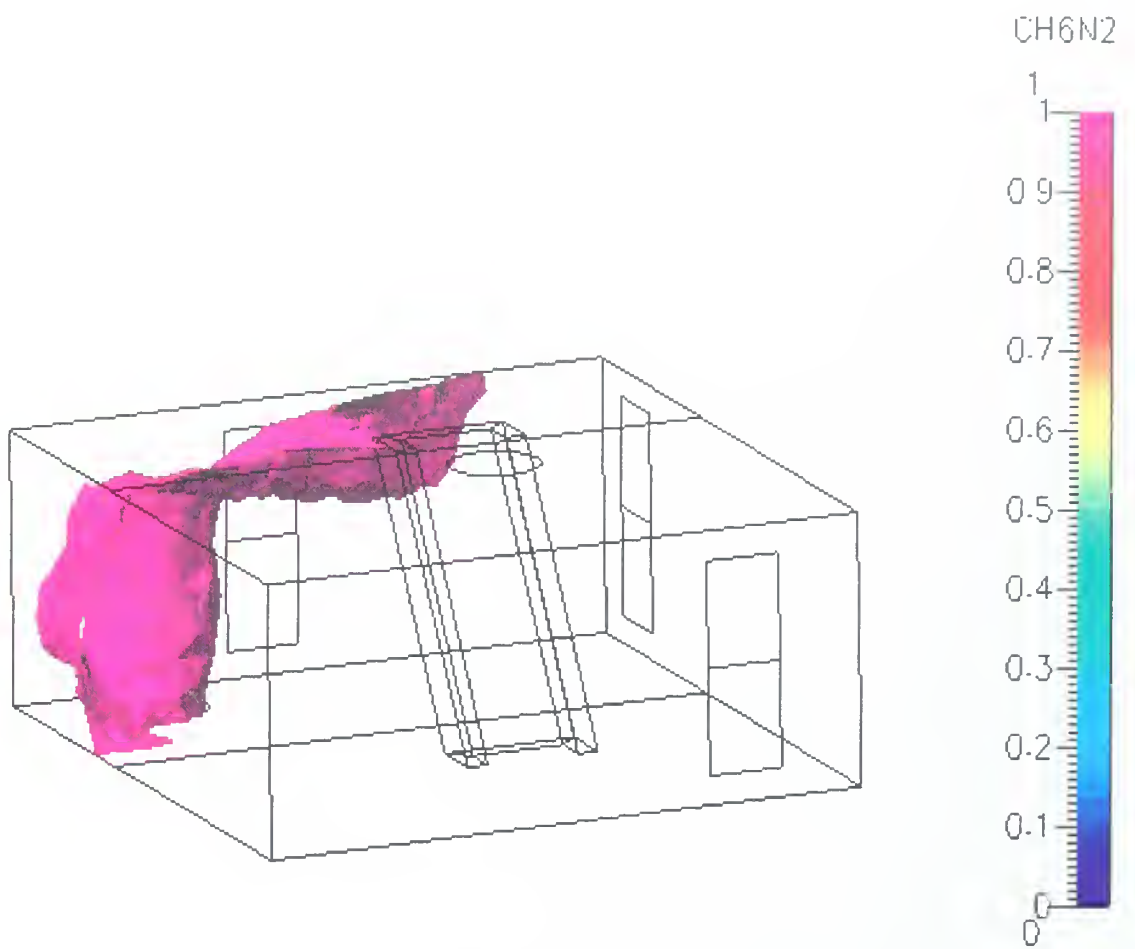
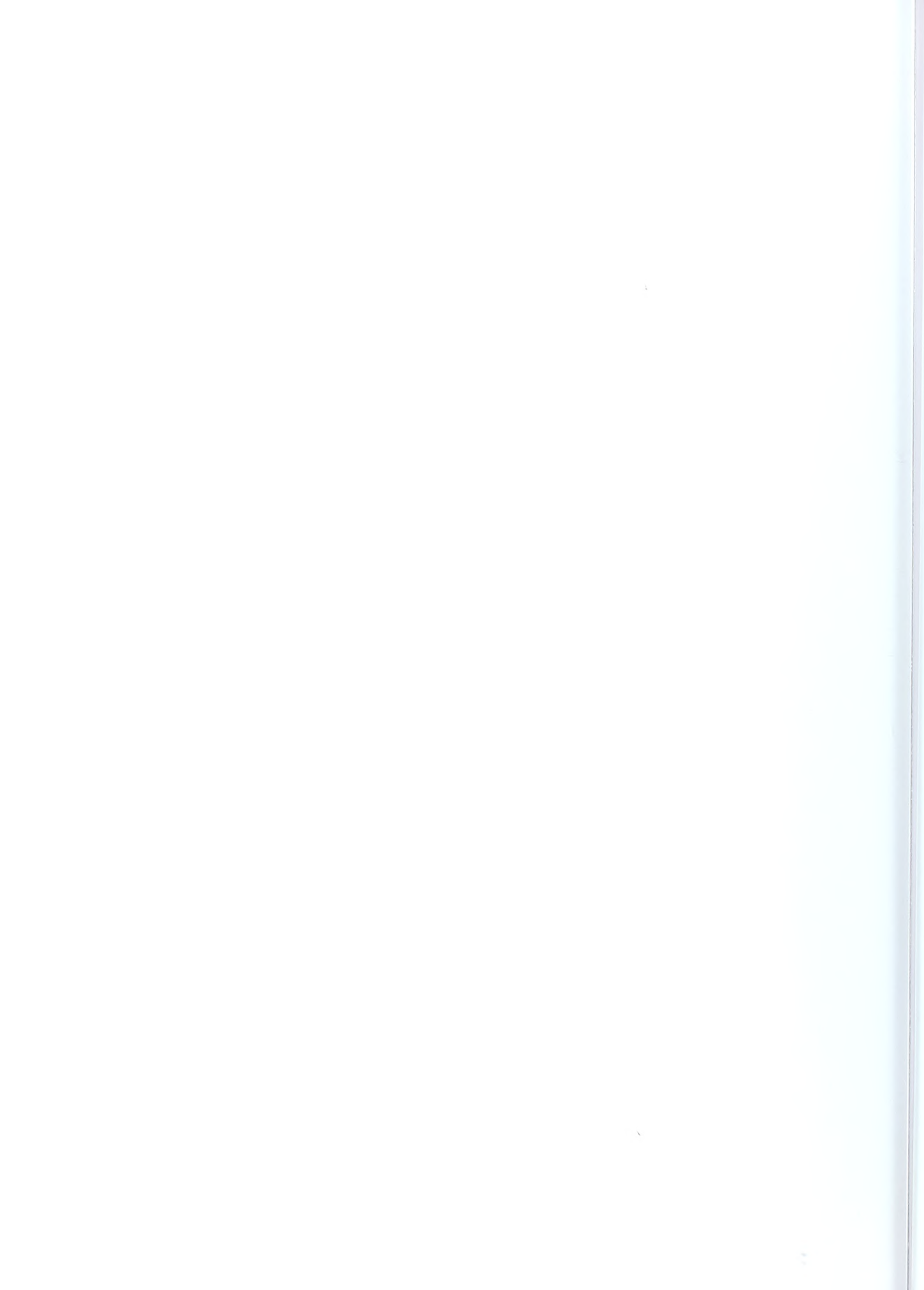

Figure 18. 99% Smoke concentration in compartment 01-163-2-L.



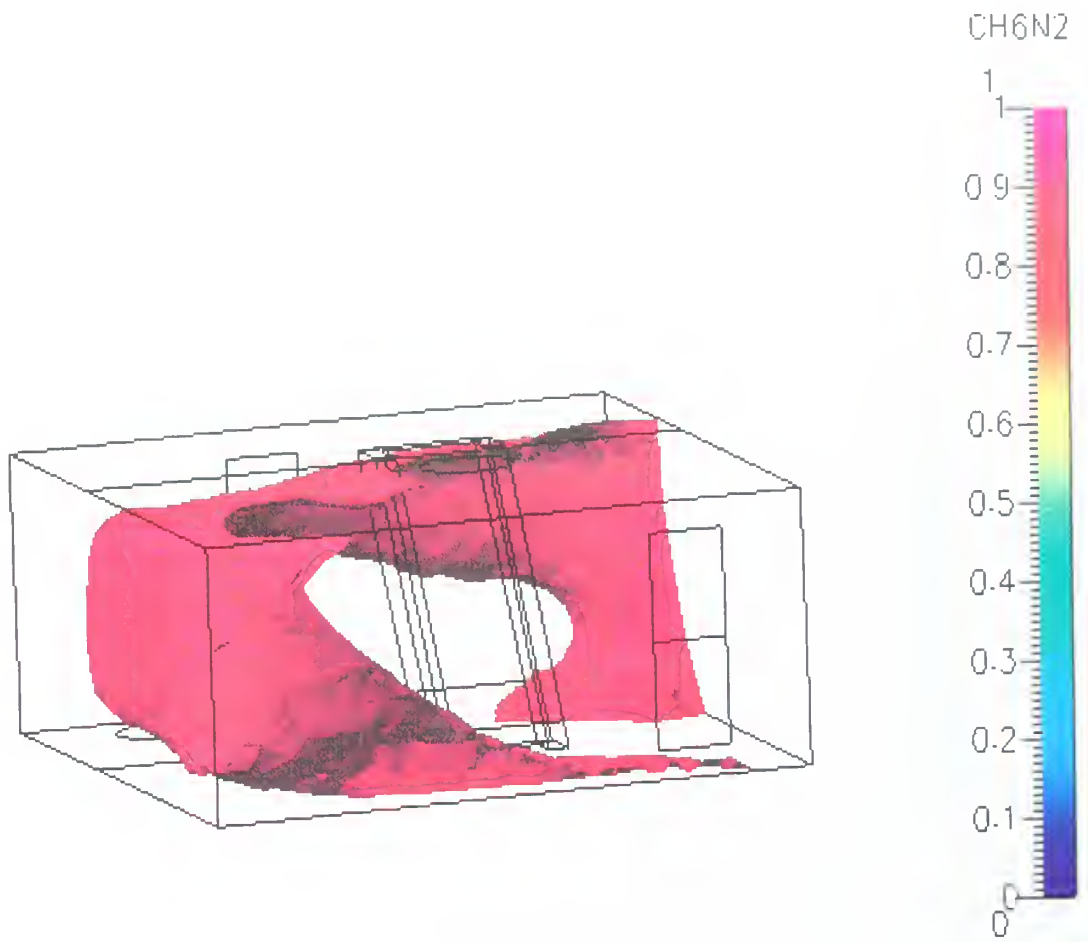

Figure 19. 80% Smoke concentration in compartment 01-163-2-L.



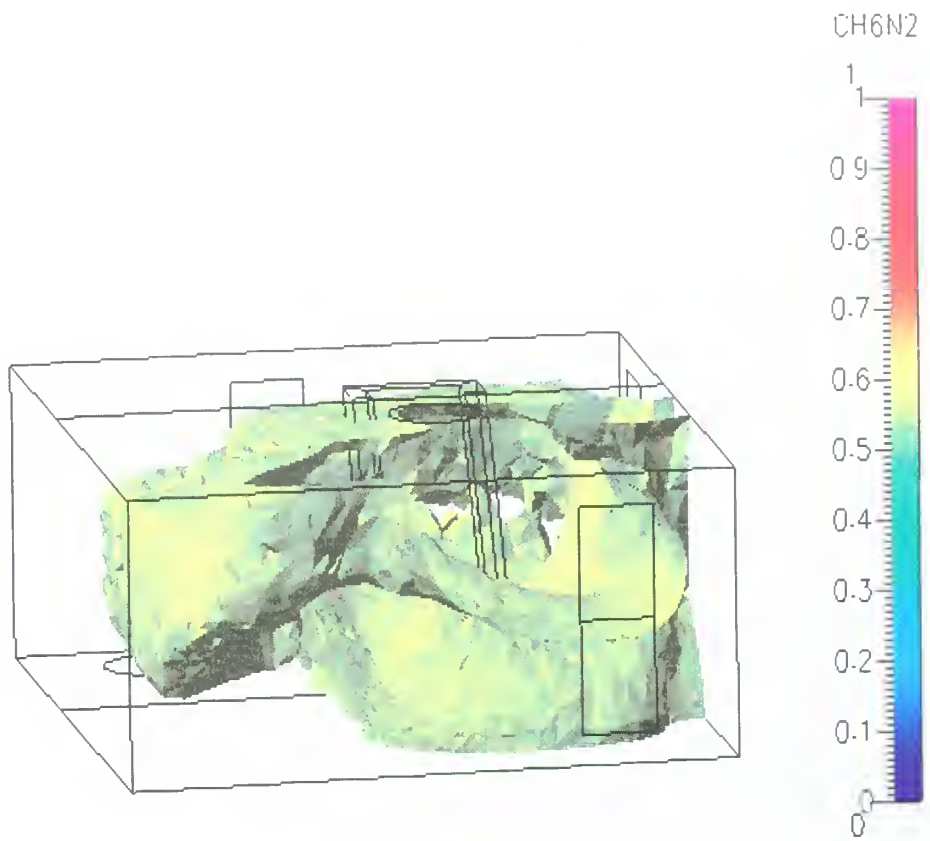

Figure 20. 54% Smoke concentration in compartment 01-163-2-L.



## LIST OF REFERENCES

1. Levinson, J., Edwards, R., *Missile Inbound*, Naval Institute Press, Annapolis, Maryland, 1997.
2. *Surface Warfare Officer Basic Engineering Division Officer Course*, Student Guide Volume 64a. Dec 1990.
3. Eldridge, J., *Damage Limitation Exercises the Minds of Naval Planners*, Jane's Navy International Volume 104, May 1999.
4. Jones, W. W., Walton, D.W., *Spread of Smoke in an FFG7*, National Bureau of Standards, 1983.
5. Jones, W.W., *A Multi-compartmental Model for the Spread of Fire, Smoke, and Toxic Gases*, Fire Safety Journal, National Bureau of Standards, 1985.
6. Forney, G.P., Jones, W. W., *Modeling Smoke Movement through Compartmented Structures*, National Institute of Standards and Technology (USA), Jul. 1992.
7. Forney, G.P., Jones W.W., *Improvement in Predicting Smoke Movement in Compartmental Structures*, Building and Fire Research Laboratory, National Institute of Standards and Technology, Mar. 1993.
8. Tatem, P.A., Williams, F.W., *Modeling Missile Propellant Fires in Shipboard Compartments*, Naval Research Laboratory, Mar. 2000.
9. Mehls, M.D., *Propagation of Fire Generated Smoke in Shipboard Spaces*, M.S. Thesis, Mechanical Engineering Department, Naval Postgraduate School, Mar. 2000.
10. CFD Research Corporation, CFD-ACE Theory Manual, Jul. 2000.
11. CFD Research Corporation, CFD-GEOM, Jul. 2000.
12. CFD Research Corporation, CFD-ACE(U), Jul. 2000.
13. CFD Research Corporation, CFD-VIEW, Jul. 2000.

THIS PAGE INTENTIONALLY LEFT BLANK



## INITIAL DISTRIBUTION LIST

1. Defense Technical Information Center.....2  
8725 John J. Kingman Road, Ste 0944  
Ft Belvoir, Virginia 22060-6218
  
2. Dudley Knox Library.....2  
Naval Postgraduate School  
411 Dyer Road  
Monterey, Ca 93943-5101
  
3. Engineering & Technology Curricular Office, Code 34.....1  
Naval Postgraduate School  
Monterey, Ca 93943-5101
  
4. Department of Mechanical Engineering Code ME.....1  
Naval Postgraduate School  
Monterey, Ca 93943-5101
  
5. Professor Matthew D. Kelleher.....2  
Mechanical Engineering Department, Code ME/KK  
Naval Postgraduate School  
Monterey, Ca 93943-5101
  
6. Amado F. Abaya, LT,USN.....1  
2095 Hopkins Road  
Getzville, NY 14068
  
7. CFD Research Corporation.....1  
Cummings Research Park  
215 Wynn Drive  
Huntsville, Alabama 35805
  
8. NAWC-Weapons Division.....1  
Fire Research Office Code: 4B3100D  
Attn: L. Bowman  
China Lake, California 93555-6100
  
9. NAWC-Weapons Division.....1  
Fire Research Office Code: 4B3100D  
Attn: Jim Hoover  
China Lake, California 93555-6100

10. NAVSEA 05P3.....1  
Attn: Norm Yarbrough  
2531 Jefferson Davis Highway  
Arlington, VA 22242-5160

11. Dr. Evalgelos Hytopoulos.....1  
Manager, West Coast Branch  
CFD Research Corporation  
4962 El Camino Real  
Los Altos, CA 94022

12. LT Mike Mehls.....1  
NSWC Dahlgren Division  
Attn: Code C2E-MSO  
17320 Dahlgren Rd  
Dahlgren, VA 22448-5100



DUDLEY KNOX LIBRARY



3 2768 00379405 8

□