



2011-06

Advanced Undersea Warfare Systems

Emmersen, Tracy

Monterey, California. Naval Postgraduate School

<http://hdl.handle.net/10945/6959>



Calhoun is a project of the Dudley Knox Library at NPS, furthering the precepts and goals of open government and government transparency. All information contained herein has been approved for release by the NPS Public Affairs Officer.

Dudley Knox Library / Naval Postgraduate School
411 Dyer Road / 1 University Circle
Monterey, California USA 93943

<http://www.nps.edu/library>



Naval Postgraduate School

ADVANCED UNDERSEA WARFARE SYSTEMS

by

Systems Engineering Analysis Cohort 17, Team B

June 2011

Approved for public release; distribution is unlimited
Prepared for: Naval Postgraduate School
Monterey, CA 93943

THIS PAGE INTENTIONALLY LEFT BLANK

REPORT DOCUMENTATION PAGE*Form Approved*
OMB No. 0704-0188

Public reporting burden for this collection of information is estimated to average 1 hour per response, including the time for reviewing instructions, searching existing data sources, gathering and maintaining the data needed, and completing and reviewing this collection of information. Send comments regarding this burden estimate or any other aspect of this collection of information, including suggestions for reducing this burden to Department of Defense, Washington Headquarters Services, Directorate for Information Operations and Reports (0704-0188), 1215 Jefferson Davis Highway, Suite 1204, Arlington, VA 22202-4302. Respondents should be aware that notwithstanding any other provision of law, no person shall be subject to any penalty for failing to comply with a collection of information if it does not display a currently valid OMB control number. **PLEASE DO NOT RETURN YOUR FORM TO THE ABOVE ADDRESS.**

1. REPORT DATE (DD-MM-YYYY) 01-06-2011		2. REPORT TYPE Technical Report		3. DATES COVERED (From - To) 05-08-2010 – 01-06-2011	
4. TITLE AND SUBTITLE ADVANCED UNDERSEA WARFARE SYSTEMS				5a. CONTRACT NUMBER	
				5b. GRANT NUMBER	
				5c. PROGRAM ELEMENT NUMBER	
6. AUTHOR(S) Systems Engineering Analysis Cohort 17, Team B				5d. PROJECT NUMBER	
				5e. TASK NUMBER	
				5f. WORK UNIT NUMBER	
7. PERFORMING ORGANIZATION NAME(S) AND ADDRESS(ES) NAVAL POSTGRADUATE SCHOOL MONTEREY, CA 93943-5000				8. PERFORMING ORGANIZATION REPORT NUMBER NPS-SE-11-004	
9. SPONSORING / MONITORING AGENCY NAME(S) AND ADDRESS(ES) N/A				10. SPONSOR/MONITOR'S ACRONYM(S)	
				11. SPONSOR/MONITOR'S REPORT NUMBER(S)	
12. DISTRIBUTION / AVAILABILITY STATEMENT Approved for public release; distribution is unlimited					
13. SUPPLEMENTARY NOTES The views expressed in this thesis are those of the authors and do not reflect the official policy or position of the Department of Defense or the United States Government.					
14. ABSTRACT Over the next twenty years, the proliferation of threats in the undersea environment will likely challenge the platform-centric model that the United States Navy uses to maintain dominance in Undersea Warfare (USW). Meanwhile, rapidly maturing technologies offer greater capabilities to potential adversaries around the world. Such a paradigm creates an imperative for the Navy to harness emerging technologies to maintain USW dominance amid a dynamic threat environment, while balancing cost, risk, and required performance. This systems engineering analysis develops Advanced Undersea Warfare Systems (AUWS) that provide a technological and tactical advantage based on the needs of the war-fighter. Following critical analysis of the numerous possible alternatives for performing the necessary Command, Control, Communications, Computers, Intelligence, Surveillance, and Reconnaissance (C4ISR) and prosecution and an objective screening process, four system architectures, and associated operational concepts, are selected for detailed analysis. From cost, risk, and performance analyses, superior AUWS concepts are shown to be flexible, scalable, and tailorable systems that balance critical need areas. This analysis highlights the need for new warfare systems that can meet future challenges to the traditional platform-centric model for USW dominance. Using the results and recommendations in this analysis will allow the Navy to deploy capabilities that effectively and efficiently meet future operational needs.					
15. SUBJECT TERMS Advanced Undersea Warfare Systems, AUWS, USW, UUV, Littoral, Chokepoint, Network-Centric, MIW, Underwater Networks, Unmanned, Autonomous					
16. SECURITY CLASSIFICATION OF:			17. LIMITATION OF ABSTRACT UU	18. NUMBER OF PAGES 339	19a. NAME OF RESPONSIBLE PERSON JAMES DRENNAN
a. REPORT UNCLASSIFIED	b. ABSTRACT UNCLASSIFIED	c. THIS PAGE UNCLASSIFIED			19b. TELEPHONE NUMBER (include area code) 404-964-1003

THIS PAGE INTENTIONALLY LEFT BLANK

NAVAL POSTGRADUATE SCHOOL
Monterey, California 93943-5000

Daniel T. Oliver
President

Leonard A. Ferrari
Executive Vice President and
Provost

This report was prepared by the students of Systems Engineering Analysis Cohort 17, Team B of the Systems Engineering Analysis program as an integral part of their educational process and in partial fulfillment of the requirements for the degree of Masters of Science in Systems Engineering.

Reproduction of all or part of this report is authorized.

This report was prepared by:

LCDR Tracy Emmersen
MAJ Ong Zi Xuan
LCDR Wes Wessner
MAJ Wong Chee Heng
LT Phil Castaneda
LT Jim Drennan
LT Scott Harvey
LT Matt Malinowski
LT Thomas Mills

CPT Ng Kiang Chuan
CPT Perh Hong Yih Daniel
LT Jon Saburn
LT Christian Silvestrini
CPT Sor Wei Lun
CPT Teo Yong Kiong
LT William Walker
CPT Kelvin Zhu
MES Chang Chung Wei

Mr. David Chiam
Mr. Koh Wee Yung
Mr. Lim Choon Wee
Mr. Lu Zheng Liang
Mr. Pek Wee Kok
Mr. Tan Yick Fung
Mr. Wee Hong Chuan

Reviewed by:

John Osmundson
SEA-17B Capstone Project Advisor

James Eagle
OPNAV SEA Chair

Clifford Whitcomb
Department of Systems Engineering

Robert Dell
Department of Operations Research

Released by:

Karl A. van Bibber, Ph.D.
Vice President and Dean of Research

THIS PAGE INTENTIONALLY LEFT BLANK

Abstract

Over the next twenty years, the proliferation of threats in the undersea environment will likely challenge the platform-centric model that the United States Navy uses to maintain dominance in Undersea Warfare (USW). Meanwhile, rapidly maturing technologies offer greater capabilities to potential adversaries around the world. Such a paradigm creates an imperative for the Navy to harness emerging technologies to maintain USW dominance amid a dynamic threat environment, while balancing cost, risk, and required performance. This systems engineering analysis develops Advanced Undersea Warfare Systems (AUWS) that provide a technological and tactical advantage based on the needs of the warfighter. Following critical analysis of the numerous possible alternatives for performing the necessary Command, Control, Communications, Computers, Intelligence, Surveillance, and Reconnaissance (C4ISR) and prosecution and an objective screening process, four system architectures, and associated operational concepts, are selected for detailed analysis. From cost, risk, and performance analyses, superior AUWS concepts are shown to be flexible, scalable, and tailorable systems that balance critical need areas. This analysis highlights the need for new warfare systems that can meet future challenges to the traditional platform-centric model for USW dominance. Using the results and recommendations in this analysis will allow the Navy to deploy capabilities that effectively and efficiently meet future operational needs.

THIS PAGE INTENTIONALLY LEFT BLANK

Table of Contents

List of Acronyms and Abbreviations.....	xix
Executive Summary.....	xxii
Acknowledgements.....	xxv
1. Introduction.....	1
1.1 Project Team.....	1
1.2 Project Background and Literature Review.....	4
1.3 Critical Assumptions.....	6
1.4 Systems Engineering Process.....	8
2. Needs Analysis.....	11
2.1 Stakeholder Analysis.....	11
2.1.1 Methodology.....	11
2.1.2 Classification.....	11
2.1.2.1 Internal Stakeholders.....	12
2.1.2.2 External Stakeholders.....	14
2.1.3 Stakeholder Interview Results.....	16
2.1.3.1 Decision Makers.....	16
2.1.3.2 Integrators.....	18
2.1.3.3 Implementers.....	20
2.1.3.4 External Stakeholders.....	22
2.1.4 Stakeholder Analysis Results.....	22
2.2 Problem Definition.....	23
2.3 Operational Concept.....	27
2.3.1 Deployment (pre-Phase 0).....	28
2.3.2 Monitoring (Phase 0).....	29
2.3.3 Area Denial (Phase 1).....	29
2.3.4 Prosecution (Phase 2-3).....	30
2.3.5 Recovery/Neutralization (Phase 4).....	30
2.4 Non-Technical Issues.....	31
2.4.1 Perception of Mine Warfare.....	31
2.4.2 Rules of Engagement.....	32
2.4.3 International Maritime Law.....	33
2.5 Specific Areas of Need.....	34
3. Functional Analysis and Allocation.....	38
3.1 Functional Analysis.....	38
3.1.1 Functional Mapping.....	38
3.1.2 Functional Decomposition.....	39
3.1.2.1 Provide Structure.....	40
3.1.2.2 Provide Power.....	40
3.1.2.3 Perform C3.....	42
3.1.2.4 Maneuver.....	46
3.1.2.5 Perform ISR.....	50
3.1.2.6 Prosecute.....	51
3.1.2.7 Provide OPSEC.....	53

3.1.3 Functional Flow.....	54
3.2 Functional Allocation.....	56
3.2.1 Alternative Generation.....	57
3.2.2 Preliminary Concept Development.....	62
3.2.3 Concept Narrowing.....	64
3.2.3.1 Criteria.....	64
3.2.3.2 Results.....	66
3.2.4 Design of Experiments.....	67
4. Overview of Selected Concepts.....	71
4.1 Squid.....	71
4.1.1 Physical Description.....	72
4.1.2 Functional Description.....	74
4.1.3 Deployment.....	76
4.1.4 Operational Employment.....	78
4.1.5 Recovery.....	78
4.2 V-CAP (Variable CAPability).....	79
4.2.1 Physical Description.....	79
4.2.2 Functional Description.....	80
4.2.3 Deployment.....	82
4.2.4 Operational Employment.....	83
4.2.5 Recovery.....	85
4.3 Large Diameter UUV (LD-UUV).....	85
4.3.1 Physical Description.....	85
4.3.2 Functional Description.....	86
4.3.3 Deployment.....	88
4.3.4 Operational Employment.....	89
4.3.5 Recovery.....	92
4.4 Glider.....	92
4.4.1 Physical Description.....	93
4.4.2 Functional Description.....	93
4.4.3 Deployment.....	95
4.4.4 Operational Employment.....	96
4.4.5 Recovery.....	97
5. Analysis of Alternatives.....	98
5.1 Performance Analysis.....	98
5.1.1 Modeling and Simulation.....	99
5.1.1.1 Methodology.....	99
5.1.1.2 Model Scenario and Setup.....	102
5.1.1.3 V-CAP Model.....	103
5.1.1.4 LD-UUV Model.....	104
5.1.1.5 Glider Model.....	105
5.1.1.6 Squid Model.....	106
5.1.1.7 Modeling and Simulation Results.....	108
5.1.2 Endurance Analysis.....	110

5.1.2.1 Methodology.....	110
5.1.2.2 V-CAP Endurance.....	113
5.1.2.3 LD-UUV Endurance.....	113
5.1.2.4 Glider Endurance.....	114
5.1.2.5. Squid Endurance.....	114
5.1.2.6 Endurance Analysis Results.....	115
5.1.3 Maneuverability Analysis.....	115
5.1.3.1 Capability for Deployment by both Contemporary and Future Platforms.....	115
5.1.3.2 Capability for Recovery by both Contemporary and Future Platforms.....	117
5.1.4 OPSEC Analysis.....	118
5.1.5 Performance Analysis Results.....	120
5.1.6 Overall Measure of Effectiveness.....	121
5.1.6.1 Analytical Hierarchy Process.....	122
5.1.6.2 Quality Functional Deployment.....	127
5.1.6.3 OMOE Determination.....	131
5.1.7 Sensitivity Analysis.....	133
5.1.7.1 Endurance Sensitivity.....	134
5.1.7.2 Communications Sensitivity.....	135
5.1.7.3 Deployment Sensitivity.....	136
5.1.7.4 Recovery Sensitivity.....	137
5.1.7.5 Detection Sensitivity.....	138
5.1.7.6 Prosecution Sensitivity.....	139
5.1.7.7 Detection Avoidance Sensitivity.....	139
5.1.7.8 Sensitivity Analysis Results.....	140
5.1.8 Performance Analysis Summary.....	140
5.1.8.1 V-CAP.....	141
5.1.8.2 LD-UUV.....	141
5.1.8.3 Squid.....	141
5.1.8.4 Glider.....	142
5.2. Cost Analysis.....	142
5.2.1 Research and Development Cost.....	143
5.2.2 Procurement Cost.....	144
5.2.3 Operations and Support Cost.....	144
5.2.3.1 Common Equipment and General Assumptions.....	145
5.2.3.2 LD-UUV Cost Estimate.....	146
5.2.3.3 V-CAP Cost Estimate.....	147
5.2.3.4 Glider Cost Estimate.....	148
5.2.3.5 Squid.....	150
5.2.4 Disposal Cost.....	150
5.2.5 Cost Analysis Summary.....	151
5.3 Risk Analysis.....	151
5.3.1. Risk Factors.....	153
5.3.2. Risk Management.....	155
5.3.3 V-CAP Risk Assessment.....	157

5.3.4 LD-UUV Risk Assessment.....	157
5.3.5 Glider Risk Assessment.....	158
5.3.6 Squid Risk Assessment.....	159
5.3.7 Risk Analysis Summary.....	160
5.4 Comparison to the Status Quo.....	162
5.4.1 Performance Assessment.....	163
5.4.2 Cost Assessment.....	164
5.4.3 Risk Assessment.....	165
5.4.3.1 SSN.....	165
5.4.3.2 Glider.....	166
5.4.3.3 LD-UUV.....	166
5.4.3.4 Squid.....	166
5.4.3.5 V-CAP.....	167
5.4.4 Comparison to the Status Quo Summary.....	167
5.5 Recommended Alternative.....	168
5.5.1 Overall Sensitivity Analysis.....	168
5.5.1.1 Performance Sensitivity.....	169
5.5.1.2 Cost Sensitivity.....	170
5.5.1.3 Risk Sensitivity.....	171
5.5.2 Recommended Alternative Summary.....	171
6. Concept Evaluation Recommendations.....	175
6.1 Primary Concept Recommendation: V-CAP.....	175
6.1.1 Improvements.....	176
6.1.2 Concept of Operations.....	178
6.1.3 Advantages.....	180
6.1.4 Disadvantages.....	181
6.2 Secondary Concept Recommendation: LD-UUV.....	182
6.2.1 Improvements.....	182
6.2.2 Concept of Operations.....	183
6.2.3 Advantages.....	184
6.2.4 Disadvantages.....	184
6.3 Comparison.....	185
6.4 Fusion of Concepts.....	185
6.5 Verification and Validation.....	186
7. Insights and Recommendations.....	189
7.1 Operational Insights.....	189
7.1.1 Flexibility.....	189
7.1.2 Scalability.....	190
7.1.3 Tailorability.....	191
7.2 Recommendations.....	192
7.2.1 Near Term.....	192
7.2.2 Middle Term.....	194
7.2.3 Far Term.....	194
8. Conclusion.....	196

Appendix A: Initial Tasking Document.....	197
Appendix B: SEA-17B Capstone Project Survey Questionnaire.....	201
Appendix C: MOEs and MOPs.....	203
Appendix D: Functional Analysis Diagrams.....	210
Appendix E: Technology Review.....	245
Appendix F: Supplementary Calculations.....	252
Appendix G: Discrimination Analysis.....	260
Appendix H: Individual Criteria Risk Considerations.....	263
Appendix I: Risk Matrices.....	266
Appendix J: Notional V-CAP Test and Evaluation Master Plan (TEMP).....	273
Works Cited.....	305
Initial Distribution List.....	313

List of Figures

Figure 1.1: Artist Rendition of a Possible Future USW Environment.....	1
Figure 1.2: SEA-17B Team Members.....	2
Figure 1.3: NMAWC Vision for Transforming Mine Warfare.....	4
Figure 1.4: Systems Engineering “VEE” Process Model.....	9
Figure 1.5: SEA-17B Project Cycle (tailored “VEE” Process Model)	9
Figure 2.1: Map of Stakeholders Analyzed.....	16
Figure 2.2: Future of USW (maintaining status quo).....	26
Figure 2.3: Future of USW (with AUWS).....	27
Figure 2.4: AUWS Operational Concept (OV-1).....	28
Figure 2.5: Historical Mine Warfare Cycles.....	31
Figure 2.6: Specific Areas of Need for AUWS.....	35
Figure 3.1: AUWS Top Level Functional Decomposition.....	40
Figure 3.2: Provide Power Functional Decomposition.....	41
Figure 3.3: Perform C3 Functional Decomposition.....	42
Figure 3.4: Command Functional Decomposition.....	43
Figure 3.5: Control Functional Decomposition.....	44
Figure 3.6: Communicate Functional Decomposition.....	46
Figure 3.7: Maneuver Functional Decomposition.....	47
Figure 3.8: Deploy Functional Decomposition.....	48
Figure 3.9: Patrol Functional Decomposition.....	48
Figure 3.10: Navigate Functional Decomposition.....	49
Figure 3.11: Recover Functional Decomposition.....	49
Figure 3.12: Perform ISR Functional Decomposition.....	51
Figure 3.13: Prosecute Functional Decomposition.....	52
Figure 3.14: Provide OPSEC Functional Decomposition.....	54
Figure 3.15: AUWS Functional Flow Block Diagram.....	55
Figure 3.16: AUWS Input/Output Model.....	56
Figure 3.17: Original Dendritic Model.....	59
Figure 3.18: Participants of AUWS Warfare Innovation Workshop.....	60
Figure 3.19: Reduced Dendritic Model.....	61
Figure 3.20: AUWS Design Space.....	68
Figure 3.21: Sampling of Possible AUWS System Architectures.....	69
Figure 4.1: Notional Squid Field.....	72
Figure 4.2: Squid Nodes.....	73
Figure 4.3: 155mm Long Range Land Attack Projectile.....	74
Figure 4.4: Ragone Plot of Electrochemical Devices.....	75
Figure 4.5: DDG-1000 Advanced Gun System.....	77
Figure 4.6: RoboClam® Digging Kinematics and Soil Fluidization.....	78
Figure 4.7: V-CAP Hunter (left) and Killer (right).....	80
Figure 4.8: Submarine Launch of V-CAP.....	83
Figure 4.9: Deployment of V-CAP Sensor Nodes.....	83
Figure 4.10: V-CAP Operation and Engagement.....	84
Figure 4.11: AUWS Large Diameter UUV.....	86

Figure 4.12: Submarine Deployment of LD-UUV.....	89
Figure 4.13: LD-UUV Deploying Paired Sensor Nodes.....	90
Figure 4.14: LD-UUV Operation and Engagement.....	91
Figure 4.15: Submarine Recovery of LD-UUV.....	92
Figure 4.16: Glider UUV.....	93
Figure 4.17: Surface Deployment of Glider.....	96
Figure 4.18: Glider Network Operation.....	97
Figure 4.19: Glider Recovery Assisted by Helicopter Retrieval.....	97
Figure 5.1: Screen shot of ExtendSim model (V-CAP).....	100
Figure 5.2: Sample graphical output of MATLAB model (Squid).....	100
Figure 5.3: Sample screen shot of Simkit (Glider).....	101
Figure 5.4: Baseline Model Scenario.....	102
Figure 5.5: V-CAP Engaging Threat UUV.....	104
Figure 5.6: LD-UUV Engaging Threat Submarine.....	105
Figure 5.7: Glider Engaging Threat Surface Vessel.....	106
Figure 5.8: Average Sensor Coverage vs Squid Nodes Deployed.....	107
Figure 5.9: Squid Engaging Threat Tanker.....	108
Figure 5.10: Need Area Weighting Results.....	127
Figure 5.11: Functional Weighting Results.....	129
Figure 5.12: MOE Weighting Results.....	131
Figure 5.13: Endurance Sensitivity.....	134
Figure 5.14: Communications Sensitivity.....	135
Figure 5.15: Deployment Sensitivity.....	136
Figure 5.16: Recovery Sensitivity.....	137
Figure 5.17: Probability of Detection Sensitivity.....	138
Figure 5.18: Probability of Kill Sensitivity.....	139
Figure 5.19: Detection Avoidance Sensitivity.....	139
Figure 5.20: Performance Analysis Results Summary (OMOE).....	140
Figure 5.21: Life Cycle Cost Estimate.....	143
Figure 5.22: Overall Risk Factor Analysis for AUWS Concepts.....	155
Figure 5.23: Risk Analysis Logical Flow Chart.....	156
Figure 5.24: Individual Criteria Risk Factors for AUWS concepts.....	161
Figure 5.25: Consequence Risk Factors for AUWS concepts.....	161
Figure 5.26: Performance Sensitivity.....	169
Figure 5.27: Cost Sensitivity.....	170
Figure 5.28: Risk Sensitivity.....	171
Figure 5.29: Overall Concept Scoring.....	172
Figure 5.30: Cost vs. Performance.....	173
Figure D.1: Provide Power FFBD.....	210
Figure D.2: Distribute Power FFBD.....	211
Figure D.3: Generate Power FFBD.....	212
Figure D.4: Perform C3 FFBD.....	213
Figure D.5: Command FFBD.....	213
Figure D.6: Process Status FFBD.....	214

Figure D.7: Process ISR Data FFBD.....	214
Figure D.8: Control FFBD.....	215
Figure D.9: Communicate FFBD.....	215
Figure D.10: Maneuver FFBD.....	216
Figure D.11: Deploy FFBD.....	217
Figure D.12: Patrol FFBD.....	218
Figure D.13: Navigate FFBD.....	219
Figure D.14: Recover FFBD.....	219
Figure D.15: Perform ISR FFBD.....	220
Figure D.16: Collect Intelligence FFBD.....	221
Figure D.17: Prosecute FFBD.....	222
Figure D.18: Engage FFBD.....	222
Figure D.19: Provide OPSEC FFBD.....	223
Figure D.20: Minimize Risk of Detection FFBD.....	223
Figure D.21: Minimize Risk of Compromise FFBD.....	224
Figure D.22: AUWS A0.....	225
Figure D.23: AUWS IDEF0.....	226
Figure D.24: Provide Structure A0.....	226
Figure D.25: Provide Power A0.....	227
Figure D.26: Perform C3 A0.....	228
Figure D.27: Maneuver A0.....	229
Figure D.28: Perform ISR A0.....	230
Figure D.29: Prosecute A0.....	231
Figure D.30: Provide OPSEC A0.....	232
Figure D.31: Provide Power IDEF0.....	233
Figure D.32: Distribute Power IDEF0.....	234
Figure D.33: Generate Power IDEF0.....	234
Figure D.34: Perform C3 IDEF0.....	235
Figure D.35: Command IDEF0.....	236
Figure D.36: Process Status IDEF0.....	236
Figure D.37: Process ISR Data IDEF0.....	237
Figure D.38: Control IDEF0.....	237
Figure D.39: Communicate IDEF0.....	238
Figure D.40: Maneuver IDEF0.....	238
Figure D.41: Deploy IDEF0.....	239
Figure D.42: Patrol IDEF0.....	239
Figure D.43: Navigate IDEF0.....	240
Figure D.44: Recover IDEF0.....	240
Figure D.45: Perform ISR IDEF0.....	241
Figure D.46: Collect Intelligence IDEF0.....	242
Figure D.47: Prosecute IDEF0.....	242
Figure D.48: Engage IDEF0.....	243
Figure D.49: Provide OPSEC IDEF0.....	243
Figure D.50: Minimize Risk of Detection IDEF0.....	244

Figure D.51: Minimize Risk of Compromise IDEF0.....	244
Figure E.1: NASA TRL Meter.....	245
Figure E.2: Quickstrike Family of Mines.....	246
Figure E.3: Submarine Launched Mobile Mine.....	247
Figure E.4: CVLWT (same hardware as CRAW).....	248
Figure E.5: Seaweb Buoy.....	249
Figure E.6: Seahorse AUV.....	250
Figure E.7: Prototype L2D2 Body.....	251
Figure F.1: Drag Coefficients of Cylindrical Bodies in Axial Flow.....	253
Figure F.2: Approaching Target Model.....	256
Figure F.3: Pd as a Function of Range of CPA (Attempted Model).....	259
Figure F.4: Pd as a Function of Range of CPA (Optimistic).....	259
Figure G.1: IBM's Watson Competing on Jeopardy!.....	260
Figure G.2: Watson Server Racks (10 total).....	261
Figure G.3: Discrimination Process for LD-UUV Sensor Nodes.....	262
Figure J.1: Master Functional Dendritic.....	277
Figure J.2: Partial Dendritic for Capability.....	278
Figure J.3: Overview of AUTECH Geography.....	285
Figure J.4: Scenario Diagram.....	287
Figure J.5: Run Profile Diagram.....	289

List of Tables

Table 1.1: SEA-17B Team Members.....	3
Table 1.2: Apparent Advantages between Manned and Unmanned Systems.....	8
Table 2.1: Stakeholder Classification Matrix.....	12
Table 3.1: Functional Need Traceability.....	39
Table 3.2: ONR Levels of Autonomy for UAVs.....	45
Table 3.3: Scoring Matrix.....	66
Table 3.4: Various Levels Considered for AUWS Factors.....	68
Table 5.1: Modeling and Simulation Results.....	108
Table 5.2: Endurance Analysis Results.....	113
Table 5.3: Deployment Scoring.....	116
Table 5.4: Recovery Scoring.....	117
Table 5.5: Detection Avoidance Scoring.....	119
Table 5.6: Summary of Performance Analysis Results.....	121
Table 5.7: Need Area Comparison.....	123
Table 5.8: The Saaty AHP Rating Scale.....	124
Table 5.9: Need Area Pairwise Analysis.....	125
Table 5.10: House of Quality 1 (Needs to Functions).....	128
Table 5.11: House of Quality 2 (Functions to MOEs).....	130
Table 5.12: Performance Score Normalization.....	132
Table 5.13: Overall Measure of Effectiveness.....	133
Table 5.14: Summary of Twenty Year Cost Estimates (FY11 \$M).....	151
Table 5.15: Weighting Legend.....	153
Table 5.16: Total Risk Factor Results by System.....	154
Table 5.17: V-CAP Risk Factors.....	157
Table 5.18: LD-UUV Risk Factors.....	158
Table 5.19: Glider Risk Factors.....	159
Table 5.20: Squid Risk Factors.....	160
Table E.1: SLMM Specifications.....	247
Table F.1: Power Calculations for Various Speeds.....	253
Table F.2: Range Calculations for Various Speeds.....	254
Table H.1: Power Considerations.....	263
Table H.2: C3 Considerations.....	263
Table H.3: ISR Considerations.....	264
Table H.4: Armament Considerations.....	264
Table H.5: OPSEC Considerations.....	264
Table H.6: Maneuver Considerations.....	265
Table J.1: Critical Technical Parameters.....	276
Table J.2: Critical Operational Issues.....	278
Table J.3: Test Objective Matrix.....	283
Table J.4: COIs Addressed.....	288

List of Acronyms and Abbreviations

Acq	Acquisitions
ADCAP	Advanced Capability
AOR	Area of Responsibility
ASW	Antisubmarine Warfare
AUTEC	Atlantic Undersea Test and Evaluation Center
AUWS	Advanced Undersea Warfare Systems
BDA	Battle Damage Assessment
BOE	Back of the Envelope
C3	Command, Control, and Communications
C4ISR	Command, Control, Communications, Computers, Intelligence, Surveillance, and Reconnaissance
CBASS	Common Broadband Advanced Sonar System
CCR	Call Completion Rate
CCSG	Commander, Carrier Strike Group
CEO	Chief Executive Officer
CESG	Commander, Expeditionary Strike Group
CJCS	Chairman, Joint Chief of Staff
CNO	Chief of Naval Operations
CO	Commanding Officer
COCOM	Combatant Commander
COI	Critical Operational Issue
COP	Common Operational Picture
COTS	Commercial Off the Shelf
CPA	Closest Point of Approach
CPU	Central Processing Unit
CRAW	Compact Rapid Attack Weapon
DE	Directed Energy
DES	Discrete Event Simulator
DICASS	Directional Command-Activated Sonobuoy System
DoD	Department of Defense
DOE	Design of Experiments
EEZ	Exclusive Economic Zone
EM	Electromagnetism
EMCON	Emissions Control
EO	Electro-optical
ERGM	Extended Range Guided Munition
ESM	Electronic Support Measures
FFBD	Functional Flow Block Diagram
GAO	Government Accounting Office
GPS	Global Positioning System
I/O	Input/Output
IR	Infrared
ISR	Intelligence, Surveillance, and Reconnaissance

KPP	Key Performance Parameter
L2D2	Large Diameter, Long Duration
LCCE	Life Cycle Cost Estimate
LCS	Littoral Combat Ship
LRLAP	Long Range Land Attack Projectile
MAC	Multiple All-up-round Canister
MAFC	Magnesium-Air Fuel Cell
MCM	Mine Countermeasures
MCR	Message Completion Rate
MCT	Message Completion Time
MIW	Mine Warfare
MOE	Measure of Effectiveness
MOP	Measure of Performance
NCA	National Command Authority
NDIA	National Defense Industrial Agency
NM	Nautical Mile
NMAWC	Naval Mine and Anti-Submarine Warfare Command
NPS	Naval Postgraduate School
O&S	Operation and Support
OMOE	Overall Measure of Effectiveness
ONI	Office of Naval Intelligence
ONR	Office of Naval Research
OODA	Observe, Orient, Decide, Act
OPLANS	Operation Plans
OPORDS	Operation Orders
OPSEC	Operational Security
OTH	Over the Horizon
PEO	Program Executive Officer
PMS	Program Manager-Ships
POTUS	President of the United States
PPBE	Planning, Programming, Budgeting, and Execution
PSU-ARL	The Applied Research Laboratory at Penn State University
QFD	Quality Functional Deployment
R&D	Research and Development
RCS	Radar Cross-section
RDT&E	Research, Development, Test, and Evaluation
RF	Radio Frequency
ROE	Rules of Engagement
SAIC	Science Applications International Corporation
SE	Systems Engineering
SEA	Systems Engineering Analysis
SEA-17B	Systems Engineering Analysis Cohort 17, Team B
SECDEF	US Secretary of Defense
SECNAV	US Secretary of the Navy

SK	Supply Clerk
SME	Subject Matter Expert
SoS	System of Systems
SSGN	Guided Missile Submarine
SSN	Attack Submarine
SSP	Sound Speed Profile
SUPPO	Supply Officer
SWDG	Surface Warfare Development Group
TDSI	Temasek Defense Systems Institute
TEMP	Test and Evaluation Master Plan
TOTO	Tongue of the Ocean
TRL	Technology Readiness Level
UAV	Unmanned Aerial Vehicle
USV	Unmanned Surface Vehicle
USW	Undersea Warfare
UUV	Unmanned Underwater Vehicle
VPT	Virginia Payload Tube
WPN	Weapons Procurement

Executive Summary

Over the next twenty years, the wide range of potential threats proliferating in the undersea environment, ranging from asymmetric to highly advanced, will likely challenge the platform-centric model that the United States Navy uses to maintain dominance in Undersea Warfare (USW). In the contested littoral waters where employment is likely, the Navy cannot accept the risk incurred by relying on multi-billion dollar assets to control the undersea battlespace.

Meanwhile, rapidly maturing technology in the fields of autonomous command and control systems, unmanned vehicles, distributed undersea networks, and energy capacity, to name a few, offer greater capabilities to navies around the world while lowering the barriers for entry into USW. Such a paradigm creates an imperative for the Navy to harness emerging technologies to maintain USW dominance amid a dynamic threat environment, while balancing cost, risk, and required performance. This systems engineering analysis utilizes a comprehensive, objective, and forward leaning approach to develop Advanced Undersea Warfare Systems (AUWS) that provide a technological and tactical advantage based on the needs of the warfighter.

AUWS proactively maintains USW dominance through weapons, sensing, and communications superiority, capitalizing specifically on netted and unmanned systems. Identified from extensive stakeholder interviews and analysis, AUWS addresses the following critical need areas: the ability to be deployed and recovered by a wide range of platforms; the ability to operate covertly; the ability to maintain persistent forward presence independent of supporting assets; the ability to develop an internal tactical picture and contribute to an external common operational picture; the ability to operate in a range of modes from fully autonomous to direct human control; the ability to discriminate between threats and non-threats (either autonomously or with human assistance); and the ability to prosecute enemy manned and unmanned assets. Together, these need areas address the most pressing aspects of the problem facing the Navy in the undersea battlespace; however, each area must be balanced with the others, which leads to a design tradespace. Within that tradespace, a multitude of possible alternatives exist that could perform the Command, Control, Communications, Computers,

Intelligence, Surveillance, and Reconnaissance (C4ISR) and prosecution necessary to dominate the USW environment.

Following critical analysis of the possibilities and an objective screening process, four system architectures, and associated operational concepts, are selected for detailed analysis. These alternatives consider both new and proven technologies applied to both traditional and developmental tactics to offer four distinct approaches to enhance USW dominance in the future. Results of comprehensive cost, risk, and performance analyses show that systems that effectively balance risk with required performance provide the most utility for the Navy in the future USW environment. Specifically, the top capabilities defined in this study balance the degree of distribution of the network (i.e. network-centricity) with centralized firepower, as neither extreme proves effective in addressing critical needs.

Analysis of the alternatives reveals three key qualities for AUWS: **flexibility**, **scalability**, and **tailorability**. AUWS is flexible with respect to deployment and recovery platforms, communication networks, and levels of autonomy. This flexibility allows operational commanders the freedom to employ AUWS in a variety of environments and operational phases, while integrating with the larger fleet network to form a human-machine team. AUWS is scalable to a range of operational areas and threat environments because the operational commander can adjust area coverage and performance by incrementally allocating the appropriate number of units to the given mission. AUWS is tailorable to the specific needs of the mission. Whether the priority is early warning or active prosecution, the operational commander can configure AUWS to yield a tactical advantage and frustrate the enemy's ability to counter the system.

While this analysis does reveal important characteristics for AUWS, more importantly it shows the need for new warfare systems that can meet future challenges to the traditional platform-centric model for USW dominance. By using the insights gained from this analysis as a guideline, a path to persistent USW dominance is developed. In the near term, detailed analysis of AUWS and the future undersea battlespace should continue, while rapid prototypes should be fielded in the fleet to garner feedback on how the systems and operational concepts can be improved. In the intermediate time frame, a Program of Record, perhaps similar to the concepts developed in this analysis, should be initiated based on the research of an AUWS Future Naval Capabilities Manager. It is recommended that the technological aspects of AUWS be developed

in parallel to prevent specific technologies from stalling an otherwise capable system. In particular, it is recognized that autonomous threat discrimination is the single greatest technical challenge for AUWS; however, even larger non-technical (e.g. political, legal, ethical) issues exist for autonomous weapons. Mitigation measures, such as adjustable autonomy, allow for the development of AUWS in a timely manner. The DoD acquisition process should be given significant lead time to allow for full operational capability by 2030. The specific nature of an AUWS program is not as important as the initiation of the process.

The undersea battlespace of the future is a complex, dynamic environment that cannot be neatly divided along platform or community lines. Based on the results of this analysis, the Navy should posture itself – at all levels – to take advantage of the opportunities presented by the changing undersea battlespace. As technology continues to mature, Advanced Undersea Warfare Systems should be a critical element of such a posture. Using the results and recommendations in this analysis will allow the Navy to deploy capabilities that effectively and efficiently meet future operational needs.

Acknowledgements

The students of Systems Engineering Analysis Cohort 17, Team B would like to thank our advisors – **Dr. John Osmundson, Professor of Information Sciences, NPS, and RADM (ret.) Rick Williams, Chair of Mine and Expeditionary Warfare, NPS** – for their guidance and patience as our team navigated toward project completion.

SEA-17B would also like to thank the following persons and the Wayne E. Meyer Institute for their instruction and dedication to excellence in preparing us to complete this capstone project.

VADM Richard Hunt, USN
RADM (ret.) Jerry Ellis, NPS
RADM Scott Hebner, USN
RADM (ret.) Paul Shebalin, NPS
CAPT (ret.) James Eagle, NPS
CAPT (ret.) Wayne Hughes, NPS
CAPT (ret.) Jeff Kline, NPS
CAPT (ret.) Carol O’Neal, NPS
CAPT Doug Otte, USN
CAPT (ret.) Paul Rinn, WBB
CAPT Jaswinder Singh, Indian Navy
CDR Doug Burton, USN
LTC (ret.) Mark Stevens, NPS
LCDR Elaine Brunelle, USN
LCDR Pascal Gagnon, RCN
LCDR Paul Kutia, USN
LCDR Scott Miller, USN
LCDR Harrison Schramm, USN
LT Benjamin Abeto, USN
LT Robert Blanchard, USN
LT Forrest Geer, USN
LT Jesse Lorenzen, USN
LT Chee Wee Ng, RSN
LT Dennis Palaniuk, USN
LT Christopher Tilley, USN
LTJG Scott Bishop, USN
LTJG Nusret Denizci, Turkish Navy
Barbara Berlitz, NPS
Phillip Bernstein, NSWC PCD
Robert Button, RAND
Charles Calvano, NPS
Joseph Cichock, Lockheed Martin

Dr. Tim Chung, NPS
David DeMartino, Columbia Group
Dr. David Drumheller, ONR
Dave Everhart, NSWC PCD
Dr. James Galambos, PSU ARL
Dr. Robert Harney, NPS
David Hebert, WBB
Randy Hill, NMAWC
Eric Holmes, Lockheed Martin
Dr. Tom Huynh, NPS
Dr. Edouard Kujawski, NPS
Gary Langford, NPS
Ross Lindman, Columbia Group
John Lloyd, NPS
Gifford Martin, PMS 495
Cameron Matthews, NSWC PCD
Tony Matthews, ITT
Dr. Daniel Nussbaum, NPS
Katie Oropeza, NPS
Richard Paquette, Boeing
Dr. Joe Rice, NPS
Dr. P.W. Singer, Brookings Institution
Jeff Smith, Bluefin Robotics
Bill Solitario, NPS
Sandra Stephens, NPS
Greg Vaughn, SAIC
Dr. Clifford Whitcomb, NPS

The entire organizations of the Naval Mine and Anti-submarine Warfare Command, San Diego and the Naval Surface Warfare Center, Panama City

Finally, we would like to thank our families for their patience and understanding through the duration of our studies. Without their selfless support, none of this would have been possible.

1. Introduction

Undersea Warfare is changing rapidly. Technology that allows persistence, precision, and stealth, all while incurring minimal risk, is necessarily transforming the way navies operate in the undersea environment. Senior US Naval leadership has indicated that USW forces need to harness the latest technology in order to provide the requisite capabilities to operational commanders of the future; however, specific technologies, systems, or concepts have not been selected for development. Figure 1.1 shows just one artist's concept of what the future USW environment might look like. The rapid advance of a wide range of technologies potentially viable in USW creates the need for a thorough, objective, and forward-thinking examination of Advanced Undersea Warfare Systems (AUWS). Systems engineering analysis provides recommendations on system architecture, as well as several operational insights, that will give the Navy the advantage in the undersea environment and help it maintain maritime superiority around the world.

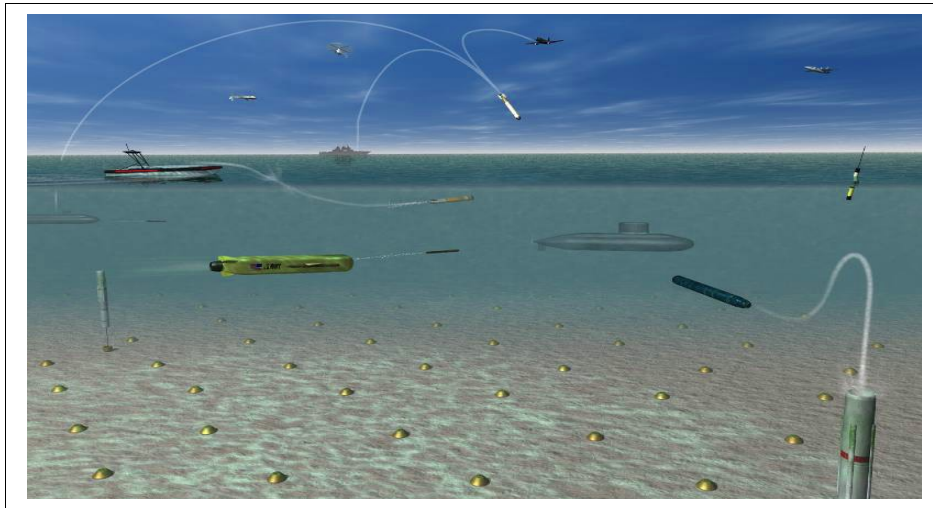

Figure 1.1: Artist Rendition of a Possible Future USW Environment¹

1.1 Project Team

The Systems Engineering Analysis Cohort 17, Team B (SEA-17B) Capstone Project Team, Figure 1.2, consists of Naval Officers from the United States and Military Officers and Professionals from Singapore studying at Temasek Defense Systems Institute (TDSI). Seven core members from the SEA curriculum at NPS started the project in the summer of 2010, while the

¹ Naval Surface Warfare Center, Panama City. [Advanced Undersea Weapon System](#). Panama City, 2010.

TDSI team members joined the project in January 2011. Table 1.1 shows the SEA-17B team members and their operational areas of experience (core SEA team members and project advisors highlighted in bold).



Figure 1.2: SEA-17B Team Members

Front Row: RADM (Ret.) Richard Williams, Lu Zheng Liang, Tan Yik Fung, LT Jonathan Saburn, LT William Walker, LT Jim Drennan, LT Philip Castaneda, Dr. John Osmundson, ME5 Chan Chung Wei, CPT Kelvin Zhu

Middle Row: Koh Wee Yung, LT Matt Malinowski, CPT Teo Yong Kiong, LCDR Alwin Wessner, LCDR Tracy Emmersen, LT Christian Silvestrini, Wee Hong Chuan, Pek Wee Kok, Lim Choon Wee, CPT Sor Wei Lun

Back Row: MAJ Ong Zi Zuan, LT Tommy Mills, MAJ Wong Chee Heng, CPT Daniel Perh, CPT Ng Kiang Chuan, David Chiam

Not Pictured: LT Scott Harvey

Table 1.1: SEA-17B Team Members

Dr. John Osmundson (NPS Faculty Advisor) Associate Professor, Information Sciences Dept.	
RADM (ret.) Rick Williams (Technical Advisor) NPS Chair of Mine and Expeditionary Warfare	
Castaneda, Phil Aviation (SH-60, USN)	Koh Wee Yung Weaponry (MoD)
Drennan, Jim (Project Manager) Surface Warfare (USN)	Lim Choon Wee Sensors (MoD)
Emmersen, Tracy (Deputy PM) Aviation (P-3)/Information Warfare (USN)	Lu Zheng Liang Weaponry (MoD)
Saburn, Jon Surface Warfare (USN)	Ng Kiang Chuan Commando (SG ARMY)
Silvestrini, Christian Surface Warfare (USN)	Ong Zi Xuan Intelligence/Infantry (SG ARMY)
Walker, William (Lead Systems Engineer) Submarine Warfare (USN)	Pek Wee Kok Networks (MoD)
Wessner, Wes Aviation (F-18)/Information Professional (USN)	Perh Hong Yih Daniel Infantry (SG ARMY)
Harvey, Scott Submarine Warfare (USN)	Sor Wei Lun Artillery (SG ARMY)
Malinowski, Matt Surface Warfare/Engineering (USN)	Tan Yick Fung Communications (MoD)
Mills, Thomas Surface Warfare/Information Warfare (USN)	Teo Yong Kiong Combat Engineer (SG ARMY)
Chan Chung Wei Technician (RSN)	Wee Hong Chuan Weaponry (MoD)
David Chiam Operations Research (MoD)	Wong Chee Heng Combat Engineer (SG ARMY)
Kelvin Zhu Combat Engineer (SG ARMY)	

The members of SEA-17B possess a wide range of operational backgrounds. US Naval Officers come from the aviation, surface, subsurface, and information dominance corps domains, while the Singaporean members represent the Army, Navy, and Ministry of Defense. Due to the many years of combined operational experience the team uses a warrior ethos in guiding their analysis. Since most team members will be moving on to operational follow-on tours, the understanding that they might one day have to depend on the system they recommend, adds

further initiative and motivation. Aside from personal investment, the Project Team’s value lies in the unique blend of operational and academic perspective of its team members. The operational experience of these naval officers combined with the engineering, analytical, and acquisitions education they have obtained at NPS and TDSI provide the Project Team the tools to effectively navigate the space between warfighter needs and delivered systems.

1.2 Project Background and Literature Review

A recent recommendation from the Commander, Naval Mine and Anti-Submarine Warfare Command (NMAWC) to the Chief of Naval Operations states that in order to maintain dominance in USW requires harnessing rapidly advancing technologies, such as Unmanned Undersea Vehicles (UUVs) and underwater networks. One particular recommendation, as shown in Figure 1.3, is to focus far-term efforts on the development of an AUWS that combines aspects of mining (MIW), mine countermeasures (MCM) and Antisubmarine Warfare (ASW). New technologies promise the ability to conduct multiple forms of USW from a single system without risking lives and expensive platforms.²

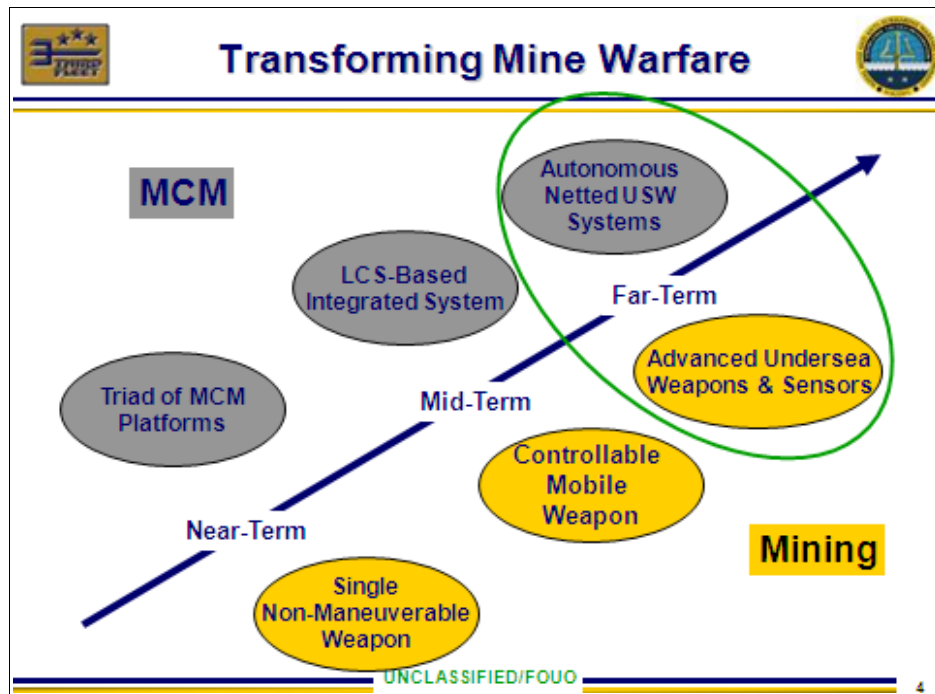

Figure 1.3: NMAWC Vision for Transforming Mine Warfare³

2 Calvano, Charles. "SEA-17 Project Tasker." Monterey: Naval Postgraduate School, 2010.

3 Naval Mine and Anti-submarine Warfare Command. Mine Warfare Update. San Diego: Department of the Navy, 2009.

From this NMAWC initiative, an Initial Tasking Document was developed to provide guidance to the Project Team. The full text of this document can be found in Appendix A. While the Initial Tasking Document is considered the only governing document for the project, several other documents have had significant influence and are worth mentioning here.

- **Unmanned Systems Roadmap:** an integrated planning document issued by the Secretary of Defense in 2009 designed to provide a common vision for future unmanned systems. Specifically, this document sets forth prioritized capability needs and broad goals to ensure unmanned systems contribute to cost-effective, transformational capabilities.⁴
- **The Navy Unmanned Undersea Vehicle Master Plan:** the Navy's guiding document on the use of Unmanned Undersea Vehicles, released in 2004. This document identifies and prioritizes the capabilities needed for UUVs and makes specific programmatic recommendations to achieve those capabilities.⁵
- **The Navy Unmanned Surface Vehicle Master Plan:** the Navy's guiding document on the use of Unmanned Surface Vehicles, released in 2007. This document defines the Navy's USV vision and defines capabilities, establishes levels of performance, and evaluates technology needs in support of that vision. Surface vehicles are not excluded from the USW environment and therefore must be considered in the AUWS analysis.⁶
- **A Survey of Missions for Unmanned Undersea Vehicles:** an independent report conducted by the RAND Corporation and sponsored by the Navy in 2009. This document analyzes and critiques the Navy's UUV Master Plan. It makes its own recommendations on how the Navy could best capitalize on the capabilities offered by UUVs.⁷
- **The Unmanned Imperative:** the final report of the Navy's Strategic Studies Group XXVIII, released in 2009. This report presents operational, organizational, and technical concepts that enable the Navy to effectively wield unmanned systems in times of peace and war.⁸

4 Office of the Secretary of Defense. Unmanned Systems Roadmap (2009-2034). Washington D.C.: Department of Defense, 2009.

5 Smith, Roger M. and Joseph A. Walsh. "The Navy Unmanned Undersea Vehicle Master Plan." 2004.

6 Thomsen, James E., Victor G. Guillory and Thomas A. Benes. The Navy Unmanned Surface Vehicle (USV) Master Plan. Washington D.C.: Department of the Navy, 2007.

7 Button, Robert W, et al. A Survey of Missions for Unmanned Undersea Vehicles. Santa Monica: RAND Corporation, 2009.

8 Hogg, James R. "The Unmanned Imperative." 2009.

In addition to these influential documents, the Project Team utilized the strategic guidance of the nation's military and civilian leadership. These documents are discussed specifically in the Stakeholder Analysis section of this report.⁹

1.3 Critical Assumptions

The Project Team makes several critical assumptions that guide this analysis and recommendations. No assumptions are made arbitrarily; they are based on personal experience, preliminary research, stakeholder guidance, and several hours of debate. The purpose of these assumptions is to scope and bound the project to a manageable level given the time and resources available.

- **Time Frame:** The system developed in this project is intended to reach initial operational capability by the year 2030. This time frame is chosen to align with NMAWC's far-term vision for AUWS and to look past the current paradigms of technology and force structure. It is assumed that Littoral Combat Ships (LCS) will effectively address littoral and MIW needs in the mid-term, but new capabilities will be necessary by the year 2030. Additionally, 2030 is selected because it represents a low point in the shipbuilding plan for operational submarines, and AUWS may be necessary to augment submarine mission capacity.¹⁰
- **Geographical Area of Interest:** Analysis of future undersea threats and the current demand for undersea ISR assets indicates that coastal waters will be the primary focus area for AUWS. Coastal Waters are defined in this report as the water from land out to 200 nautical miles (NM), coinciding with Exclusive Economic Zones (EEZs). This analysis considers strategic choke-points for their unique physical, commercial, physical, and military nature, but does not focus on those areas exclusively. Over the next twenty years, the Project Team anticipates the maritime threat, and most of the benefits of MIW, to be concentrated in coastal waters. Since the coastal waters of the world vary significantly in hydrography, an effective AUWS must be tailorable and scalable to

9 The Project Team is aware of several classified documents that could be of value to this analysis. However, because this analysis is conducted entirely at the unclassified level, those documents were not considered. It is recommended that results of this analysis be applied at the classified level, taking those documents into account.

10 O'Rourke, Ronald. Navy Force Structure and Shipbuilding Plans: Background and Issues for Congress. Washington, D.C.: Congressional Research Service, 2010.

unique requirements of the mission area of interest. Theoretically, any effective AUWS would be scalable for use in deep water scenarios but further study is required to analyze the impact of this environment on mission requirements.

- **Focus on Mine Warfare:** MIW is just one of many concepts that may benefit the analysis of AUWS. This analysis focuses on offensive MIW for its value in the future USW environment. In particular, the expected budget constraints, the need for multi-mission capabilities, and the desire to separate the warfighter from the weapon all point to MIW as an area of value. When commenting on the potential value of AUWS, VADM Richard Hunt, Commander US Third Fleet, notes that he would much prefer to deploy weapons that force the enemy to react rather than focus on clearance efforts.¹¹
- **Focus on Unmanned Systems:** This analysis focuses on unmanned systems, which are defined in this report as systems in which a human operator, if any, is not co-located with the system itself. The Project Team remained solution-neutral during the problem definition phase in accordance with systems engineering practices. However, to align with stakeholder guidance and scope the project to a manageable level, manned systems are excluded from the bulk of this analysis. A preliminary analysis, summarized in Table 1.2, indicates that unmanned systems have an apparent advantage in meeting AUWS objectives. As a control measure, a manned system is included in the analysis of alternatives to validate those advantages.

¹¹ Hunt, Richard. Personal interview. Dec. 2010.

Table 1.2: Apparent Advantages between Manned and Unmanned Systems

Factor	Manned	Unmanned
Persistent Presence		X
Power Consumption		X
Size of System		X
Onboard Communications Equipment	-	-
Onboard Engagement Processing	X	
Command and Control	X	
Operation Cost per Mission		X
Inherent Risk to the Operator		X

- The Character of the Future USW Environment. The USW environment is defined in this report as the physical and tactical domain that can be utilized to conduct military operations beneath the surface of the sea. Therefore, surface and air operations are included in the USW environment. It is assumed that maritime asymmetric warfare, such as attack from diesel submarines or small boat swarms, will remain a significant threat in the given time frame. One or more foreign navies will represent a formidable challenge to US maritime superiority, and at least one nation will possess its own version of AUWS. In addition, it is assumed that budget constraints will not be alleviated over the next twenty years.

1.4 Systems Engineering Process

This analysis meets the objectives set forth in the Initial Tasking Document through the application of Systems Engineering. In particular, a tailored SE “VEE” process model is used to guide the Project Team through the SE process to successful project completion. The “VEE” process model, an example of which is shown in Figure 1.4, addresses problem definition, system implementation, and integration while providing feedback loops in the form of verification and validation. The process is not sequential in nature; rather the tasks are executed in a parallel and iterative process throughout the project lifecycle. Figure 1.5 depicts the SEA-17B Project Cycle, which combines aspects of the tailored SE “VEE” process model with project management concerns to provide an overall graphical view of the project.

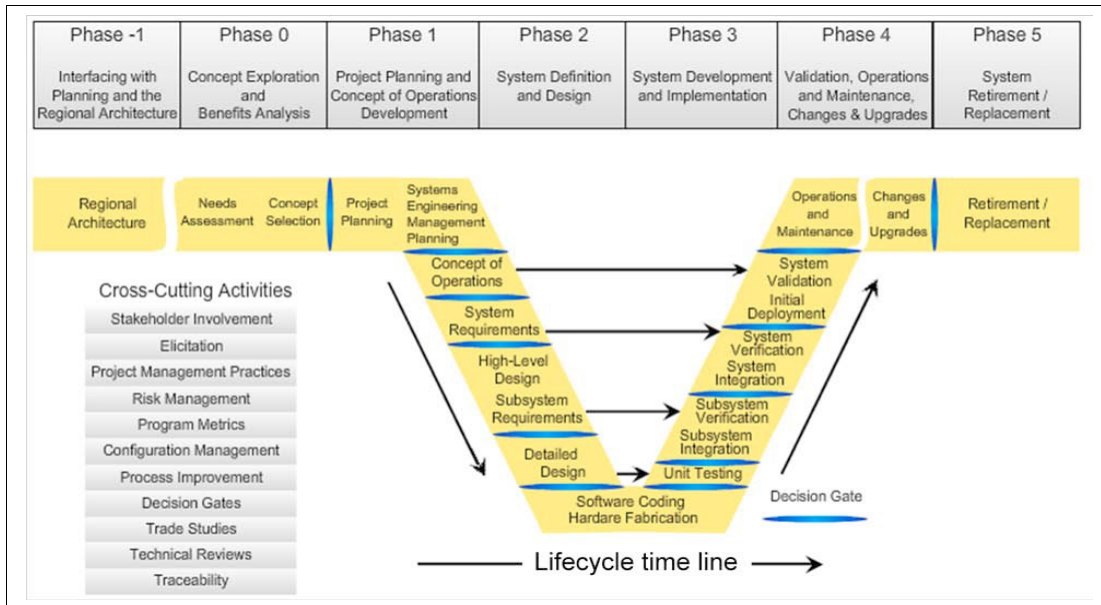

Figure 1.4: Systems Engineering “VEE” Process Model¹²

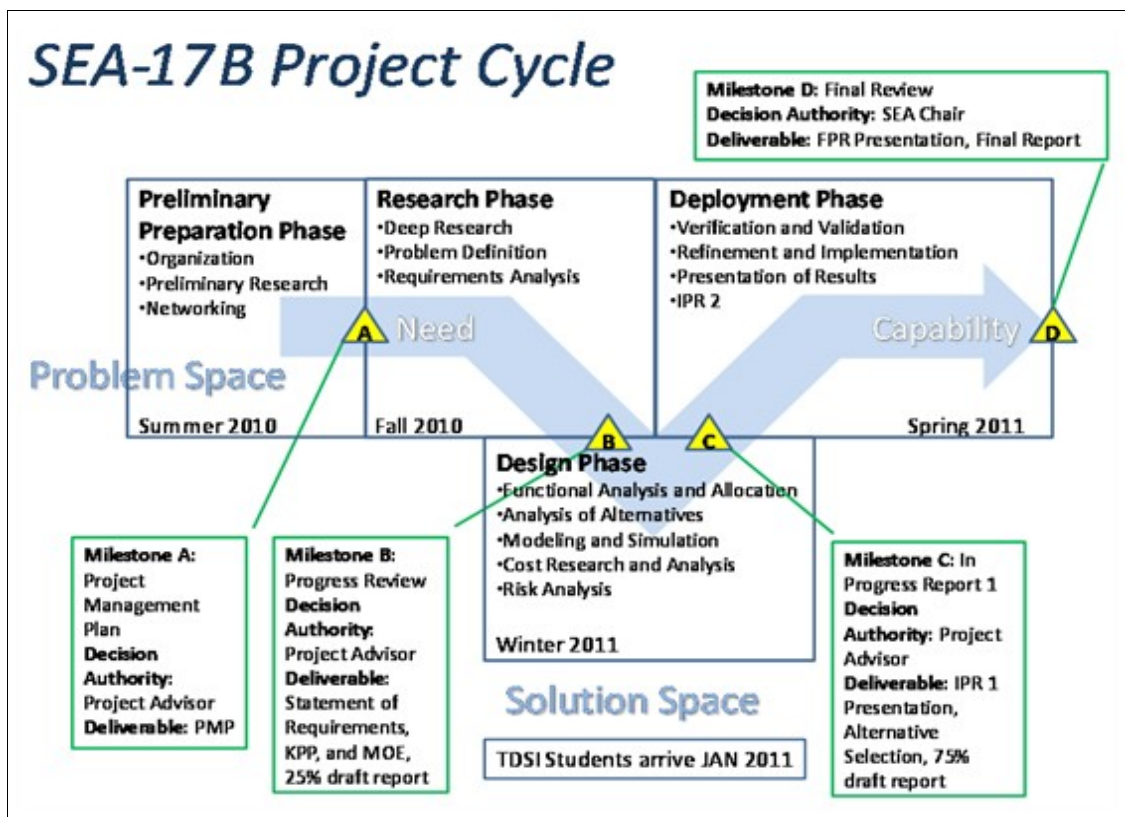

Figure 1.5: SEA-17B Project Cycle (tailored “VEE” Process Model)

12 Langford, Gary. *Systems Engineering Integration Handbook for SE4151*. Monterey: Naval Postgraduate School, 2009.

The project is divided into four basic sections aligned to the NPS academic calendar: Preliminary Preparation, Research, Design, and Deployment. The Preliminary Preparation Phase (Summer 2010) consists of team organization, networking activities, and some preliminary research.

The Research Phase (Fall 2010) consists of research and stakeholder analysis. Activities include project technical research, stakeholder interviews, and stakeholder/needs analyses. Outputs of this phase are a refined problem statement and an identification of specific needs.

The Design Phase (Winter 2011) comprises the majority of the analysis for the project. It consists of a functional analysis (including alternative generation), an analysis of alternatives, preliminary cost and risk analyses, and modeling and simulation efforts. Outputs of this phase include a selection of refined concepts for further examination and preliminary analysis results based on modeling and simulation.

The Deployment Phase (Spring 2011) consists of continued risk and cost analyses alongside the in-depth analysis of the modeling and simulation results. Although verification and validation occur throughout the project cycle to ensure traceability to stakeholder needs, the Deployment Phase is also used to thoroughly verify and validate the products and processes of the Project Team. Outputs of this phase are comprehensive recommendations based on cost, risk, and performance analyses, and key insights gained over the course of the project.

2. Needs Analysis

2.1 Stakeholder Analysis

The stakeholder analysis serves three purposes in the Systems Engineering Process. The first, problem statement construction, is the identification of specific capability gaps as defined by the personnel who will ultimately implement, operate, finance, and live with the system. The second is to drive the requirements generation and system specification from Key Performance Parameters (KPP) to lowest level criteria. The third is to provide the foundation of traceability between problem statement and system requirements for the purpose of validating the system.

2.1.1 Methodology

Using the Initial Tasking Document as a guideline, a generic questionnaire (Appendix B) is employed to address the tasked aspects of AUWS in a solution-neutral approach. A group of personnel in the operational, industrial, and research fields are selected for interview using a combination of advisor recommendations, operational experience, professional networking, and targets of opportunity. The responses to these questionnaires are then synthesized and analyzed to determine key themes that could lead to stakeholder needs and requirements.

2.1.2 Classification

The traditional paradigm of primary, secondary, and tertiary stakeholders is too simple to represent the spectrum of people invested in this project. Further, the proposed area-based organization of stakeholders into Operational, Industrial, and Research, Development, Test and Evaluation (RDT&E) bodies still does not address all of the project's facets. To fully explore the scope of the body of stakeholders, a matrix of stakeholders, shown in Table 2.1, is utilized.

Table 2.1: Stakeholder Classification Matrix

		Decision Makers	Integrators	Implementers
Internal	Operational	POTUS, SECDEF, SECNAV, CNO	COCOMs, CCSGs, CESGs	CO, Wardroom, Crew
	Industrial	CEOs	Engineers	Technicians
	Acquisitions	POTUS, Congress	DoD Acq	SUPPO/SK
	RDT&E	PEOs	LSE	SME
External	US	Taxpayers		
	Friendly	Concerned Global Citizens and Governments		
	Neutral	Concerned Global Citizens and Governments		
	Hostile	Affected Population and Governments		

This stakeholder matrix shown utilizes three tiers divided amongst two categories and their associated sub-categories. The three tiers, Decision Makers, Integrators, and Implementers, are intended to map to requirements by specification from broadest to most specific, respectively. In the highest tier are Decision Makers who directly influence the creation and direction of the system. The middle tier is comprised of Integrators who ensure the system effectively inter-operates with existing system architectures and environments. Integrators are involved in both the implementation of the system and the high level decision making process. The lowest tier consists of Implementers who are responsible for bringing the system into reality, whether in terms of acquisition, construction, operation, or research and development. The categories, Internal and External, represent the two different groups involved with any system. The Internal Stakeholders are composed of the Operational, Industrial, and RDT&E communities mentioned previously as well as the Acquisitions community. The External Stakeholders are comprised of civilians and governments from US, Friendly, Neutral, and Hostile populations.

2.1.2.1 Internal Stakeholders

Operational: For the Operational sub-category, the top tier consists of government policy makers and military decision makers, from the President to the service chiefs. The middle tier is comprised of military personnel ranging from top-level Combatant Commanders (COCOMs) to Group or Squadron Commanders. The lowest tier consists of the unit Commanding Officers,

wardrooms, and crews that will directly operate the system. This breakdown covers the needs for AUWS from the strategic level to the operational to the tactical. For example, an endurance requirement at the top tier (Decision Makers) may be specified in days. That requirement will have constituent (Integrators) requirements championed by operational commanders in the middle tier. Beyond a generic desire for a set number of days on station, there may now be specific requirements for the types of batteries or fuels to be used based on logistics and regulations. At the tactical level, even more specifics (i.e. battery capacities, current draw, etc.) will emerge as Implementer requirements.

Industrial: The Industrial sub-category represents the defense contractors operating within the military industrial complex. While one might assume that this category only applies to a specific contractor supplying AUWS, it is actually more realistic to include the contractors bidding on the project, the contractors providing similar or potentially integrating components, the contractors providing the launching platforms, and any sub-contractors needed to fulfill the acquisition. For a nominal description, the top tier is represented by a Contractor's Chief Executive Officer (CEO), the middle tier by engineers, and the lowest tier by technicians. In this hierarchy, the CEO might desire a lucrative acquisitions process, such that production costs may be minimized to improve profit margins. The engineer may favor a simple, modular, mass produced design to facilitate future upgrades and cost reduction. The technician may desire a simple design to facilitate ease of assembly. These three sets of desires address different facets of design requirements.

Acquisitions: The Acquisitions Sub-Category represents the government officials, DoD civilians and military personnel responsible for funding AUWS. The President of the United States (POTUS) not only has sole responsibility for the command of the military (Operational sub-category), but also shares responsibility with Congress for the overall financial well-being of the federal government (Acquisitions sub-category). At this level, broad requirements for cost savings and rapid acquisition may translate to a requirement for a cost-effective program of record. The stakeholders at the middle tier, consisting of various acquisitions personnel (Program Executive Officers, contracting officers, etc.) would convert the generic cost-effectiveness desires to specific metrics for program cost by phase, as determined by budget. The lowest tier of the sub-category is populated by operational logistics and supply personnel who are responsible

for funding upkeep and operations. The cost metrics would evolve further into specific requirements for time, money, and resources needed to field the system.

RDT&E: The fourth and final sub-category of External Stakeholders is RDT&E personnel, ranging from Program Executive Officers (PEO) to Systems Engineers to Subject Matter Experts (SME). This category consists of the broadest range of people and agencies. From broad military research agencies like the Office of Naval Research (ONR) to specific military warfare discipline groups like NMAWC to civilian consulting agencies staffed by mixtures of civilian and retired military personnel. In this sub-category, cutting-edge technological requirements like autonomous operation are magnified and refined as they progress downward by tier. That autonomous requirement develops communications protocols capable of integrating with existing systems at the middle tier. At the low tier, specific bandwidths and transmission rates then emerge.

2.1.2.2 External Stakeholders

The External Category is much simpler, but much larger in its composition. The multi-tier paradigm does not hold up in the External Category as the people within each sub-category more or less hold the same stake in AUWS. For this reason, there are sub-categories but no tiers among External Stakeholders. These people may not have direct contact with AUWS, but its employment will have longstanding effects on all civilians, regardless of their affiliation (i.e. sub-category).

United States Civilians: US civilians will absorb the financial burden of the program via taxes and will also carry the burden of world opinion, which may include suffering retaliation by hostile nations as a result of employment. For these reasons, factors such as cost, resource consumption, and environmental impact are legitimate concerns. To mitigate retaliation, AUWS must be effective enough to drive cessation of hostilities if employed, but must not utilize such means that excessive collateral damage (either in property or people) is caused or longstanding negative consequences are suffered by the affected peoples. Furthermore, US civilians would likely be less supportive of conventional mine warfare employment. An AUWS that possesses autonomy but lacks discrimination would essentially be a minefield. In short, AUWS must effectively discriminate its targets, operate effectively under set Rules of Engagement, and must

not use weapons of mass destruction like nuclear agents or biological toxins that may cause permanent damage to the affected ecosystem and/or populace.

Friendly and Neutral Nation Civilians: Friendly and Neutral nation populations are considered as a single group of civilians. They may not pay for the system or have to live with any collateral damage or localized environmental effects, but they must still be considered. If AUWS is unable to accurately execute missions in a fashion that does not violate international treaties and precedents (i.e. commits war crimes) then international relations may be strained. Furthermore, any combat operations occurring on the high seas or in straits and chokepoints of military significance can and will affect all sea-going nations and their economic well-being. Simply put, AUWS cannot indiscriminately damage or sink any and all ships within its tactical envelope, nor cannot it utilize methods like nuclear warheads or biological toxins.

Hostile Nation Civilians: The final sub-category, Hostile nation civilians, can include both constituents of a hostile sovereign nation state as well as the indigenous (and possibly cooperative) population of the combat zone. Applying this definition to the current conflicts in Iraq and Afghanistan for illustrative purposes, Iraqi civilians would be considered part of this sub-category as would the entire population of Afghanistan. These stakeholders will suffer direct effects of AUWS employment. Fishermen will risk injury or death due to attacks on unintended targets. Coastal peoples will suffer health and economic hardships if AUWS emits toxic or hazardous wastes. Whole populations may suffer if weapons of mass destruction are used as munitions. While it is easy to discount the intended recipients of a piece of ordnance, the civilians surrounding the target must always be considered.

The President wishes to “safeguard the sea” by “keeping strategic straits and vital sea lanes open” and “improving the early detection of emerging maritime threats.” He asserts, “We must maintain our military’s conventional superiority while enhancing its capacity to defeat asymmetric threats.” Also of note is the imperative to “spend the taxpayers’ dollars wisely.”¹³

The CNO, by virtue of his more specialized area of expertise, is more specific in his statements. In his discussion of required force levels, he states that a minimum of 313 ships are currently needed, while only 288 exist in inventory today. Further exacerbating the problem is the fact that a projected 320 ships will be needed by 2024. This disparity in supply and demand cannot be fixed by simply reducing the number of missions, nor can it be addressed by throwing more money at the problem. “Increased financial pressure” requires the Navy to ensure that its “limited resources are appropriately invested”. Simply put, the Navy cannot rely solely on an expensive, traditional platform-based acquisition program. To meet this challenge, the CNO envisions the use of high-endurance UUVs utilizing modular designs with open architecture. This vision is not without constraint, however. Just because AUWS can reduce manpower costs and risks to personnel and equipment, if it does not meet the exact requirements of the Navy at a cost that is acceptable, it will not be fielded. The need for a rigorous systems engineering process is evident in his statement: “We will question every requirement and only develop those capabilities we need, not just want.”¹⁴

From these two documents certain overarching themes emerge. The resources of the military in general and the Navy in particular are stretched thin while the mission profiles and requirements to ensure global maritime security continue to expand such that there are simply not enough platforms to handle the tasking. The country cannot realistically supply more traditional platform-based solutions in time to meet the need, much less pay to construct and operate them. Even if the country could meet every mission with the existing fleet inventory, there are some tasks that are simply too dangerous to risk a multi-billion dollar asset crewed by dozens (if not hundreds) of highly trained, well compensated individuals. A “game-changing” system is needed to meet these needs.¹⁵

13 Obama, Barack. National Security Strategy. Washington, D.C.: Office of the President of the United States, 2010. 5, 34, 50.

14 Roughead, Gary. CNO Guidance for 2011. Washington, D.C.: Office of the Chief of Naval Operations, 2011. 1, 5-7.

15 Roughead 5.

Synthesized from the desires of the President and the CNO, the following generic characteristics emerge for AUWS:

- Capability to conduct data collection and dissemination
- Capability to filter and process data to create intelligence onboard
- Capability to conduct engagement with hostile forces
- Some degree of expendability (the loss of the asset should not have an unacceptable or strategic impact)
- Minimal manning (reducing cost while raising expendability)
- Affordability (allowing larger inventory for better mission coverage while raising expendability)

2.1.3.2 Integrators

Just as the top tier stakeholder results seem to fit together nicely as a result of proximity and rigid hierarchy, the convergence of ideas diminishes somewhat as the range of stakeholders increases. There are dissenting opinions amongst responders as to whether unmanned assets are necessary and, if so, the missions that should be covered. Some stakeholders favor a given warfare area (MIW, ASW, SUW) over another, as is expected based on one's experience and preferences, but the most widespread disparity is with regard to the utility of MIW. As the Navy's offensive mining capability has been phased out, the warfare culture has changed to the point where many people use MIW and MCM interchangeably. When asked about the utility of MIW, many respond with adamant conviction that MCM is of great use to the Navy, but fail to mention anything about offensive mining.

Those responders that do respond with opinions on offensive mining generally feel that it is a warfare area that has been neglected for some time, and based on the current fiscal environment and given the wide range of maritime threats present and emerging, the Navy would do well to re-examine offensive mining as a cost-effective solution of providing area denial while protecting more valuable assets. The generally positive view of MIW is qualified with the need to take the next step forward. Rapidly advancing technologies must be harnessed to capitalize on the benefits of MIW while overcoming the traditional political obstacles to mining, such as the danger to innocents and the cost of recovery (e.g. post-hostilities minefield

clearance). To summarize: “Focus on effects. Generate asymmetric effects that are not already done better via other means. Avoid replicating the mine fields of times past. Just like laser guided munitions made dumb bombs obsolete, AUWS should make mining obsolete.”¹⁶ Beyond MIW discussion, the following focus areas emerge:

- **High Endurance.** Regardless of design, AUWS must be capable of conducting extended independent (though not necessarily autonomous) operations. More than one stakeholder mentions a need for a minimum of 30-days endurance,^{17 18 19} which stems from publicly stated CNO goals.²⁰ This analysis takes the CNO’s goal into consideration; however, the endurance requirement is also analyzed from the mission perspective. In other words, the minimum endurance needed to accomplish given tasking is estimated and compared to the CNO goal.
- **Modular.** Many responders espouse a need for a solution to multiple mission profiles, but they also stress that a “one-size-fits-all” option may not be viable, as its overall capability may be lacking as it attempts to cover all bases. For this reason, stakeholders mention either multiple systems or modular configurable systems that could be adapted to the mission at hand. ISR and Area Denial are both specifically called out in addition to conventional ASW and SUW missions.^{21 22}
- **Clandestine.** Multiple responders discuss the efficacy of keeping high value assets out of harm’s way while simultaneously inserting ISR/engagement capability without the target’s knowledge.^{23 24 25} Other stakeholders note the potential utility of notifying the enemy that AUWS has been deployed, either for deterrence or disruption purposes. Even in this case, some measure of stealth is necessary to prevent individual AUWS units from being detected and targeted. Also, the presence of a clandestine system can be announced

16 Hebert, David. Personal interview. Oct. 2010.

17 Ellis, W.G. Personal interview. Oct. 2010.

18 Everhart, Dave. Personal interview. Oct. 2010.

19 Martin, Gifford. Personal interview. Oct. 2010.

20 Standifer, Cid. "CNO Wants 30-Day Mission in Seven Years." *Inside the Navy* 22 Oct. 2010.

21 Hebert, David. Personal interview. Oct. 2010.

22 O'Donnell, Jerry. Personal interview. Oct. 2010.

23 Ellis, W.G. Personal interview. Oct. 2010.

24 Everhart, Dave. Personal interview. Oct. 2010.

25 Matthews, Tony. Personal interview. Oct. 2010.

when desired, but an overt naval presence cannot be hidden as easily. In fact, a clandestine capability enables a deterrent effect even when no system is present.

- **Cost-effective.** Most responders feel that a primary requirement for AUWS and any other UUV should be the ability to conduct a mission for less than the cost of a high value asset, mitigating the risk of financial loss. Measures taken to ensure that AUWS won't be lost or mission-killed could save even more money.²⁶

Assembling these themes with other inputs provided by Integrators results in the emergence of several specialized characteristics:

- Capability to operate independently of a tending vessel or station for periods of a month or more
- Capability to conduct clandestine operations
- Capability for recovery or self neutralization (as a caveat, the per unit cost must be driven down to support one time use)
- Capability to communicate with a host platform and other units within the system
- Capability to provide intelligence collection and dissemination with minimal time latency to support tactical action
- Capability to conduct non-lethal mission kills (mitigates the risk of collateral damage)²⁷
- Capability of deployment/recovery from multiple platforms (i.e. submerged, air, surface, or shore)
- Capability to operate autonomously or under direct operator control, and anything in between in the Man in the Loop continuum²⁸

2.1.3.3 Implementers

This stakeholder base is significantly larger than the Middle Tier base. The individual Project Team members all fit into this category, so personal experience is included in this portion of the analysis. The reduction in convergent thought observed during the transition from Integrators to Implementers is exponentially larger than the reduction seen between Decision

²⁶ Ellis, W.G. Personal interview. Oct. 2010.

²⁷ Drennan, Frank. Personal interview. 10 Oct. 2010.

²⁸ Hill, Randy. Personal interview. 16 Sept. 2010.

Makers and Integrators, which is expected, given the comparative jump in respective stakeholder pools.

This community will prove most valuable during operational testing and evaluation and actual fielding of the unit. Sailors have always been known for their ingenuity underway, and many side effects, functions and emergent behaviors that were never considered during the initial build will be discovered, exploited, or remedied by Petty Officers, Chiefs, and Officers. This notion highlights the importance of integrating AUWS into the larger force to create an effective team of man and machine. An autonomous system operating on its own, even one capable of learning, is ultimately limited by its programming and cannot capitalize on the innovation of the warfighter.

The same confusion between MIW and MCM seen among Integrators is rampant among Implementers. A complete lack of emphasis on offensive mining, the absence of training evolutions, and the removal of most mines from the USN inventory is most likely to blame. The other universal concern is the need for UUVs, provided they are easy to maintain and of good reliability.²⁹

The following characteristics are synthesized from community input and team member personal experience:

- Ease of deployment and recovery
- Ease of maintenance
- Minimal physical footprint and low weight to accommodate onboard storage and/or airlift
- Survivability
- Use of COTS technology where possible (to ease repair and operation while driving down cost)
- Security
- Reliability
- Minimal upkeep requirements for tools, cleanliness, etc.
- Minimal logistics footprint
- Capability to provide meaningful and accurate real time data

²⁹ Brunelle, Elaine. Personal interview. Oct. 2010.

2.1.3.4 External Stakeholders

Lacking representative samples of specific inputs from these populations, observation of general public opinion via news outlets and social media amongst other methods leads to a list of basic desires for the system that do not necessarily map to high, middle, or low tier.

- Should be relatively inexpensive
- Should not use nuclear fuels if the system is used as a weapon
- Should not use nuclear warheads of any type
- Should not use chemical agents/biohazards/toxins as weapons
- Should not adversely affect the ecosystem, either through the production of environmental hazards (e.g. oil slicks, radiation, hazardous waste, etc.) or disruption of marine life
- Should be recoverable or capable of neutralization/sterilization to prevent collateral damage after cessation of hostilities
- Should minimize collateral damage through target discrimination and accurate munitions delivery
- Should be capable of correctly following established Rules of Engagement, whether operating autonomously or under human control

2.1.4 Stakeholder Analysis Results

The Stakeholder Analysis is the basis of the Systems Engineering Process. If the Systems Engineer cannot identify what the customer actually needs, then the right system with the right capability cannot be provided. Further, just listening to what the customer has to say or reading the information they provide is not sufficient. Critical thought and discussion go into the culling of actual needs from discourse peppered with wants and “wouldn’t it be nice if’s.” So often, the customer may know what they need or want, but cannot accurately convey it. In other cases, the customer may not really even understand what they need, and that need must be derived from information provided.

By collecting and analyzing this information, the Initial Tasking Document refined into a relevant problem statement. That problem statement is molded into a set of needs, again via

stakeholder inputs. Those needs are then fashioned into specific, rigorous requirements with specific metrics, measures of effectiveness, and performance thresholds.³⁰

2.2 Problem Definition

While stakeholder analysis begins the formulation of a set of needs for AUWS, it does not paint the whole picture. The fundamental question of why AUWS is needed is not quite answered by studying the needs and desires of potential stakeholders. An independent analysis of the problem that AUWS must solve is necessary to fully understand how to develop the right system.

Future USW Capacity: The number of platforms available to conduct USW is at risk of falling short of operational demands in the near to mid-term future. MCM ships are being replaced by Littoral Combat Ships (LCS), of which the Navy is planning to build and operate 55 over the next 30 years. The MCM mission is just one of many, including ASW, that this modular ship is expected to conduct. If an LCS is not outfitted with an MCM or ASW Mission Package, then it would have to enter port and undergo a swap-out in order to contribute to USW missions. Other surface combatants have simultaneous multi-mission capabilities; however, since USW is just one of many missions they may be tasked with, they cannot be fully allocated to the USW force structure.

Submarines represent the majority of the USW force structure. The Navy states that 48 operational fast attack submarines (SSNs) are required to meet future needs, yet its shipbuilding plan calls for only 39 operational SSNs in the year 2030. Furthermore, as of 2006 only about half of Combatant Commander requests for SSN tasking are met. Some observers, such as retired Vice Admiral Albert Konetzni, Jr., former Commander US Pacific Fleet Submarine Force, argue that even 48 operational SSNs will be insufficient when USW missions are not comprised primarily of ISR, but more traditional USW operations against an emerging near-peer competitor.³¹

30 This analysis develops general needs, performance metrics, and measures of effectiveness. However, specific requirements and thresholds are not established here. They must be developed based on further analysis with classified information and concurrence of top level stakeholders, using this analysis as a guide.

31 O'Rourke, Ronald. Navy Force Structure and Shipbuilding Plans: Background and Issues for Congress. Washington, D.C.: Congressional Research Service, 2010.

Future USW Capability: The capabilities of the United States Navy's submarine fleet are second to none and will most likely remain unchallenged in the near future. However, there is some question as to whether this prominent capability will be able to keep pace with rapidly advancing (and proliferating) unmanned and autonomous technologies. This challenge is exacerbated by the scheduled decrease in SSN capacity. LCS is intended to contribute to USW capabilities; however, a recent Navy report indicates that the baseline ASW Mission Package does not provide sufficient capability to meet the range of expected threats.³²

Near-Peer Competitors: The traditional global order is being challenged by several emerging countries that have the ability to affect international economic and security issues. These countries are rapidly expanding and modernizing their navies as a signal of their intent to influence global politics.³³ Consequently, many countries around the world are responding with their own naval buildup amid security concerns.³⁴

Asymmetric Maritime Threats: Asymmetric maritime threats, such as small boat swarms, diesel submarines, and naval mines are easily employed over a wide geographical area by a large number of state and non-state actors. Since the threat axis is essentially 360 degrees and well-planned attacks offer negligible warning, these threats force most naval platforms into a defensive posture. Using surface combatants and SSNs to proactively counter asymmetric threats often subjects these high value assets to unacceptable levels of risk. For example, while an SSN might have the capability to clear mines or hunt a diesel submarine, these missions risk the loss of a high value asset that is often critical to the overall warfighting effort.

Autonomous Undersea Threats: Historically, torpedoes and mines have always been autonomous and unmanned to some extent. Today, however, technology allows for much wider and greater capability among autonomous undersea weapon systems. Unfortunately, this technology is not an American monopoly. Countries around the world are currently investing in UUV and related research. Eventually, an adversary of the United States will develop its own version of AUWS. These systems incur far less risk than manned platforms, giving them a significant tactical advantage.

32 O' Rourke.

33 Whiteneck, Daniel, et al. *The Navy at a Tipping Point: Maritime Dominance at Stake?*. Alexandria: Center for Naval Analysis, 2010.

34 Wander, Andrew. "Middle East in huge naval expansion." 31 March 2010. [aljazeera.net](http://english.aljazeera.net/news/2010/03/201033014527639619.html). 16 Oct. 2010 <<http://english.aljazeera.net/news/2010/03/201033014527639619.html>>.

Challenge for Platform-Centric Solutions: The wide range of potential threats creates a scalability issue for naval platforms. The shipbuilding process cannot possibly keep pace with ever changing threats armed with rapidly advancing technology. Once a naval vessel is built, it is very difficult to scale it to the level of combat it is expected to face. The modular design of LCS is an attempt at scalability, but documented problems with this approach indicate that a different solution may be necessary in the long term. In short, a vessel built to fight and win large naval battles is not necessarily ideal to confront a swarm of small boats, as the risk of loss significantly outweighs the benefit of victory. Conversely, a vessel built to defeat the mine threat is probably not designed to defeat an enemy destroyer.

The overall problem that derives from both the stakeholder analysis and this independent analysis is described in the following statement:

Over the next twenty years the capacity and capability of USW platforms will not meet operational demands in non-permissive areas. Furthermore, the emergence of near-peer competitor navies, the distributed nature of the asymmetric maritime threat, and the development of autonomous undersea threats present a unique challenge that current platform-centric solutions are not ideally designed to confront.

This problem statement is shown graphically in Figure 2.2. The red areas represent the three general threat categories expected to confront the Navy in the future USW environment, particularly in the littorals. Given the status quo, the Navy will most likely be able to handle both asymmetric and near-peer competitor threats, assuming its USW capability will overcome any capacity shortfalls. However, the very technology that is being studied in this report will generate potential new threats as quickly as the technology develops. Without capitalizing on this powerful technology, the Navy's traditional USW force structure will struggle to meet the challenge created by the combination of all three threats. Eventually, a crossover will occur after which the Navy will no longer be assured of its dominance in the USW environment.

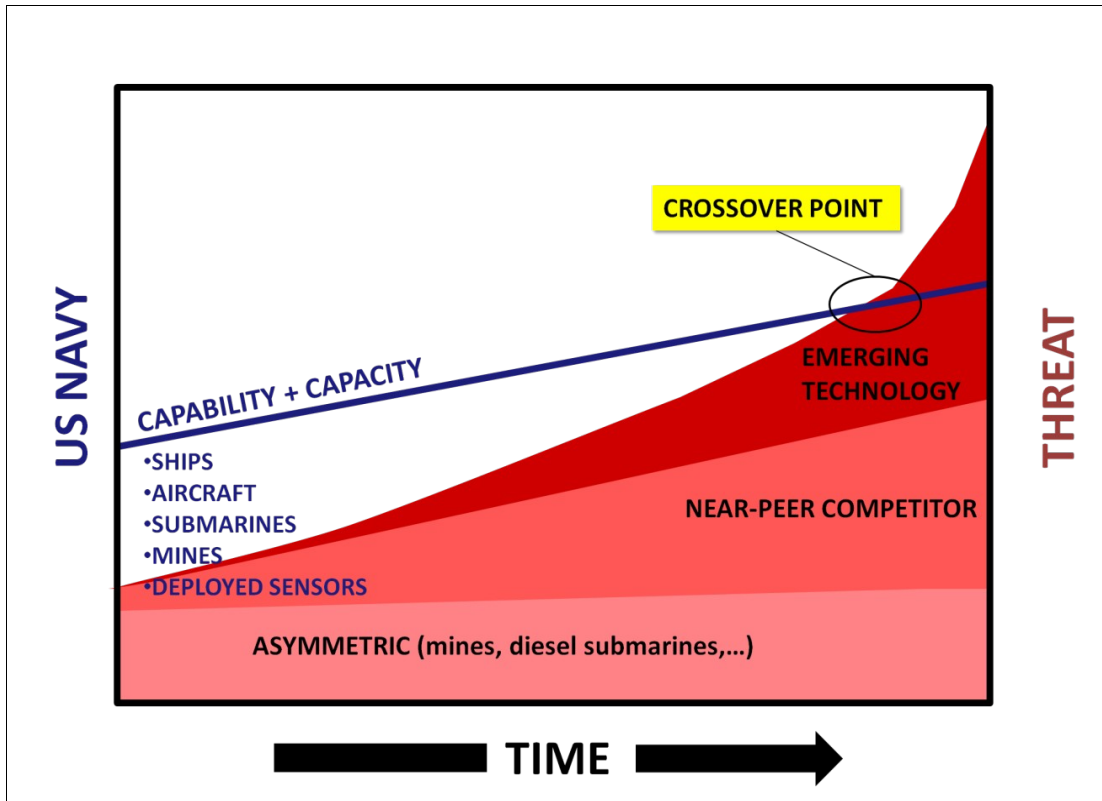

Figure 2.2: Future of USW (maintaining status quo)

Figure 2.3 depicts the scenario if the Navy harnesses rapidly emerging technology (e.g. distributed undersea networks, unmanned and autonomous control systems, miniaturized weapons and sensors). Advanced threats no longer have a comparative advantage against systems such as AUWS, which can also be effectively employed against asymmetric threats and near-peer competitors within acceptable risk limits.

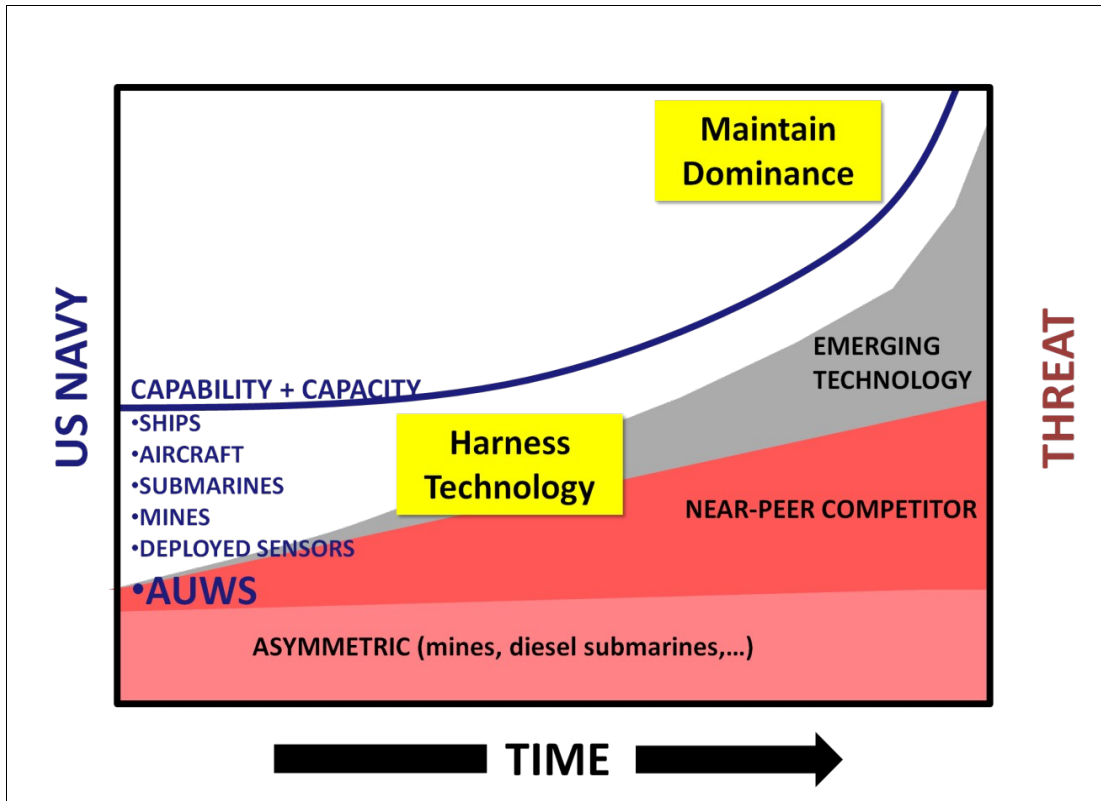

Figure 2.3: Future of USW (with AUWS)

2.3 Operational Concept

Given the potential problem facing future USW forces, an operational concept is developed for an AUWS that would help those forces meet the challenges of the future. This operational concept aids in further clarifying what capability and capacity gaps AUWS will be required to fill. The specific operational activities that must be performed will vary with the parameters of the operating environment, involved players, and specific threat. So, while every instance cannot be reasonably modeled, the following is a brief description of stressing scenarios, described by threat (near-peer, asymmetric, or autonomous) in which AUWS will accomplish its mission. To validate this operational concept, two independent analyses, conducted by students of the Joint Campaign Analysis course at NPS, examine the operational impact of AUWS in a similar scenario. Both analyses find that AUWS can contribute significantly to overall mission accomplishment, either by improving performance in critical

activities such as ASW barrier search or by reducing the number of submarines required to perform high risk missions.^{35 36}

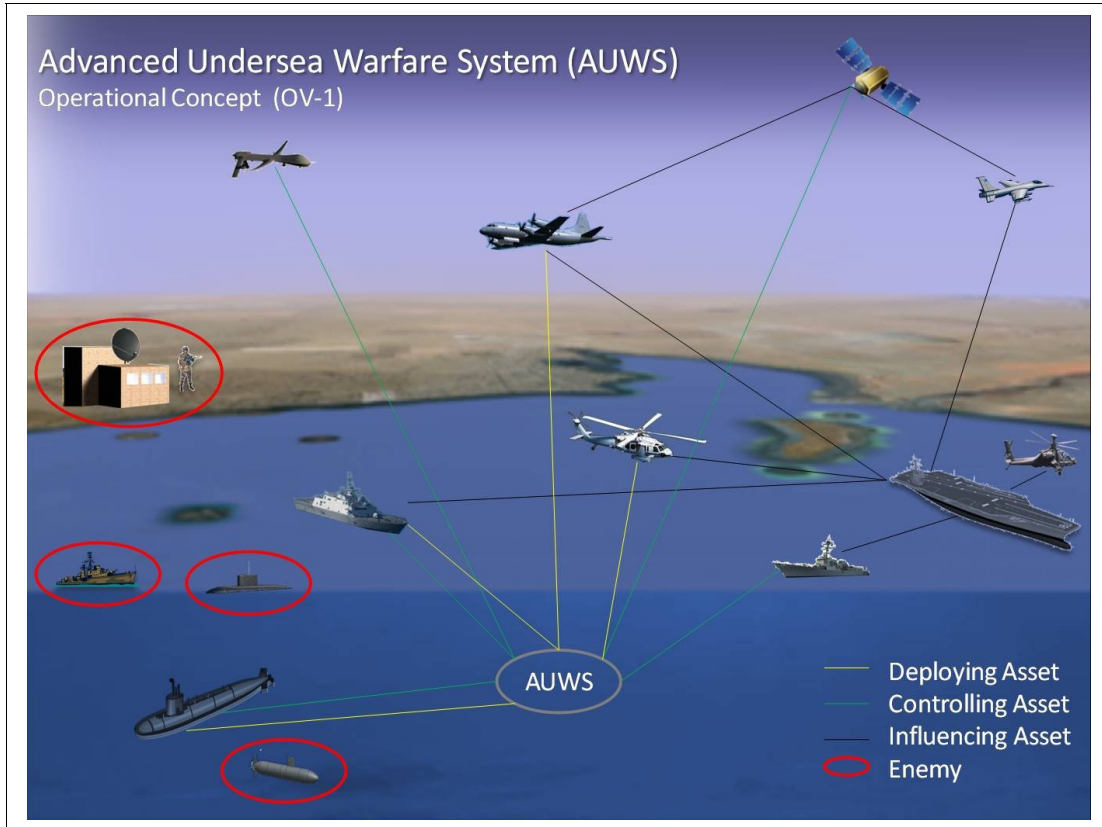

Figure 2.4: AUWS Operational Concept (OV-1)

2.3.1 Deployment (pre-Phase 0)

Consider the littoral region, as shown in Figure 2.4, surrounding a near-peer competitor during a tense geo-political climate in the 2030 time frame. The Fleet Commander designates the need for discreet early warning and battlespace preparation in the area. Maritime Patrol Aircraft are airborne and flying their normal routes. Surface ships slow briefly during a transit. SSNs covertly infiltrate the coast just outside of territorial waters. Multiple AUWS units are rapidly and covertly deployed from these platforms. Each AUWS unit energizes, verifies system continuity, and verifies programmed tasking prior to release. Onboard the launch platform, the

35 Sibley, Christy. CJTF Sea Tiger, Anti-Submarine Warfare: Impact of the Advanced Undersea Warfare System (AUWS) on the Submarine Battle. Monterey: Naval Postgraduate School, 2011.

36 Smith, David. CJTF Sea Tiger Maritime Component: Added use of VCAP Component. Monterey: Naval Postgraduate School, 2011.

system operator sets AUWS to semi-autonomous mode. Each unit autonomously transits to its designated patrol zone under its own power, using its own guidance systems. Upon arrival within its assigned patrol region, it commences area monitoring. AUWS covertly conducts ISR to establish baseline traffic patterns and provide early warning of unusual activity. Although the system is equipped with weaponry, only a human operator can initiate an engagement, via the communications gateway node, in the semi-autonomous mode.

2.3.2 Monitoring (Phase 0)

Based on the information provided by AUWS, the Fleet Commander orders further AUWS units be deployed in a strategic chokepoint near a major naval port of the adversary. The shallow waters and heavy maritime patrol density make keeping a high-value covert asset, such as an SSN, in situ for real-time ISR a risky proposition, either from a physical accessibility aspect or a counter-detection aspect. Placing a covert distributed sensor system in the area will provide early warning of increased military traffic, which may be indicative of imminent hostilities, allowing the United States to mass forces as needed to prepare. As a covert sensor, AUWS can also observe activity that occurs in the absence of prominent warships. When not actively communicating with an external network, AUWS enters a dormant mode to conserve power.

2.3.3 Area Denial (Phase 1)

The situation in the region has escalated to the point that hostilities may not be avoided. Minor skirmishes have broken out and the entire adversary fleet is preparing to mobilize. As a deterrent measure, the United States announces that it has deployed controllable, discriminatory weapons outside of each of the adversary's ports and it will give the order to engage naval warships if the fleet attempts to sortie. In reality, fully functional AUWS units are only deployed near two major naval bases. Decoys that randomly transmit acoustic signals are positioned outside of other ports. One adversary strike group ignores the warning and deploys. While the ships make it safely to sea, appropriate AUWS units are set to fully autonomous mode, denying the ships re-entry into port for resupply. Meanwhile, US Naval ships that would traditionally be required for Area Denial are free to conduct other missions.

2.3.4 Prosecution (Phase 2-3)

When those adversary ships that successfully deployed attempt to return to port, AUWS is prepared to engage. Operating in fully autonomous mode, the AUWS units do not incur a time delay or risk counter-detection from communications with an external network. AUWS engages all naval vessels attempting to transit its area of responsibility, while sparing local fishing traffic based on acoustic signature and behavior.

Meanwhile, another AUWS force is monitoring the aircraft carrier operating area. Due to the high density of friendly and neutral traffic in the area, it is operating in friendly force defense mode. The system autonomously maneuvers and sends contact reports to the combat information center aboard the aircraft carrier, but cannot conduct offensive engagements on its own. However, when a diesel submarine enters the area and fires a torpedo at the aircraft carrier, AUWS is permitted to quickly react. One AUWS unit neutralizes the torpedo before it reaches the aircraft carrier, while another prosecutes the adversary submarine.

2.3.5 Recovery/Neutralization (Phase 4)

Increasing cost constraints require AUWS to be reusable if at all feasible. AUWS must be able to deploy, operate, and be recovered by a surfaced or submerged platform in the area. However, if recovery is inadvisable due to risk, or if enemy activities detect or recover AUWS, a self-destruct capability must be present to ensure that sensitive hardware and software is not compromised.

A submarine has returned to the region just outside of the 12 nm limit to recover AUWS units conducting the area denial mission near adversary ports. Upon receiving the recall beacon, the AUWS units autonomously begin to transit to the recovery point. Internal diagnostic checks on some units indicate that underwater shock from nearby engagements have severely reduced power available for propulsion, making recovery infeasible. These AUWS units upload critical information to the rest of the AUWS network and signal their intent to scuttle themselves. This mitigates the risk of sensitive information and technology falling into enemy hands and the danger of unexploded live ordnance harming innocents, all without sacrificing lives or high value assets.

2.4 Non-Technical Issues

Akin to any technologically innovative project, AUWS faces several non-technical issues. A few of these issues warrant additional elaboration: Perception of Mine Warfare, Rules of Engagement, and International Maritime Law.

2.4.1 Perception of Mine Warfare

Over the course of naval history, mine warfare has experienced many ups and downs. This is largely due to neglect and fear coupled with periodic renewals of interest in the mine warfare discipline. Figure 2.5 illustrates the historical cycles of MCM and offensive mining. Many consider mine warfare (MIW) as an indiscriminate method of crippling or destroying vessels. This is not the primary purpose of a minefield however. Mining operations embrace many unique methods of employment. Mines are generally used to control the sea through regulation or denial of passage or access to a defined area. They can be used to inflict damage, hinder, disrupt, or deny sea going operations of an enemy.³⁷

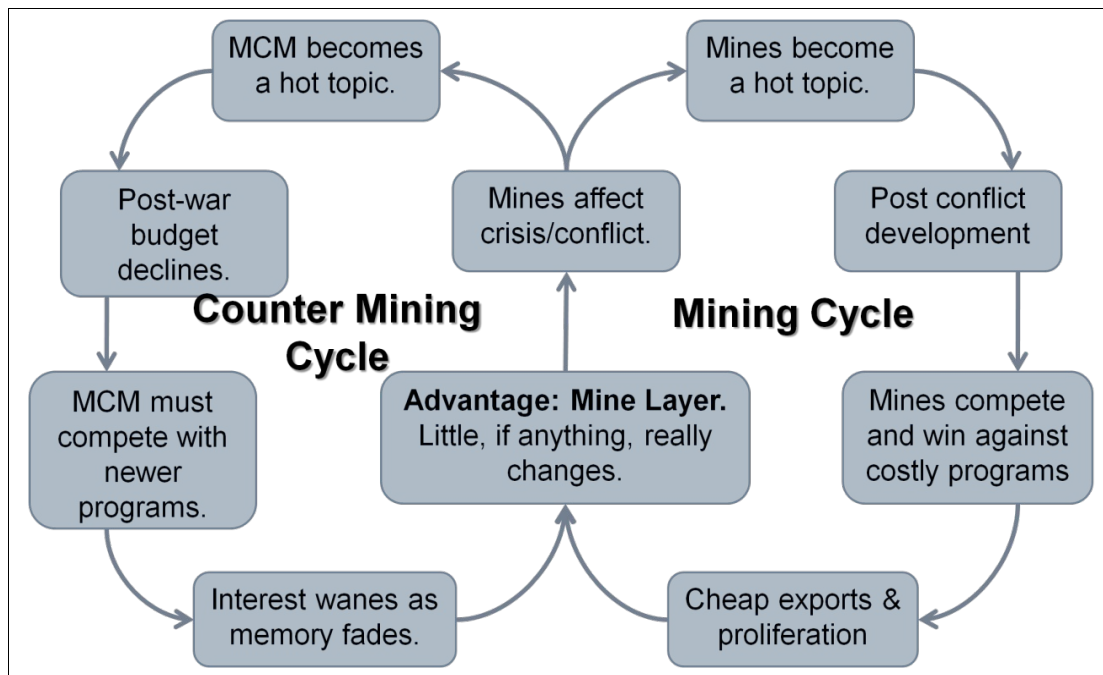

Figure 2.5: Historical Mine Warfare Cycles³⁸

37 Commander, Mine Warfare Command. *NWP 3-15*. Washington, DC: Department of the Navy, 2004. 1-2.

38 Williams, Rick. *Historical Mine Warfare Cycles*. Monterey: Naval Postgraduate School, 2011.

Traditionally minefields are used to protect ports and other high value areas by sealing off the most common methods of passage. These minefields tend to be extensive in order to ensure success. This requires a significant number of mines rendering sea lanes almost impassable to all vessel traffic. As technology evolves, the United States Navy must not overlook the viability of offensive mining in controlling waterways while mitigating manned requirements. Potentially, just a few AUWS units could effectively execute the mission (among others) of what was once a large indiscriminate minefield, significantly reducing cost and risk.

The negative connotation associated with the term “mining” is nothing new. During the Vietnam Conflict, mines were called “destructors” in order to avoid the negative political implications associated with offensive mining. Today, “effectors” is a popular term. Regardless of what terminology is used, mines have been a very useful, highly successful tool used throughout history. The traditional roadblocks of danger to innocents and cost of post-conflict cleanup are being rapidly overcome by technological advances in areas such as undersea command and control, computer processing systems, and unmanned mobile systems.

Mine Warfare is a viable force multiplier. Due to its relatively low cost of operation and outstanding suitability to the harsh maritime environment, MIW should not be ignored. Just the threat of mines can greatly influence an adversary’s psyche while crippling logistical infrastructure, thus providing an irrefutable advantage to the United States. Additionally, mines can afford a covert preemptive strike capability at very little risk to the laying force, particularly when considering smart mines. While AUWS will go further in terms of technology and operational employment, rendering the traditional notion of a mine obsolete, the principles of Mine Warfare should not be forgotten.

2.4.2 Rules of Engagement

Typically, the Rules of Engagement (ROE) for the employment of mines are described in detail in operation plans (OPLANS) and operation orders (OPORDS) as promulgated by the applicable geographic Combatant Commander. ROE comply with the laws of war as well as applicable National Command Authority (NCA) guidance throughout the range of mining operations. While ROE may vary based on the situation, certain basic concepts like the definition of a mine may need to be re-examined. Dr. P. W. Singer, author of Wired for War and senior

fellow at the Brookings Institution, notes that systems such as AUWS may have a similar impact as UAVs are having on cruise missile doctrine. According to some definitions, armed UAVs could be considered cruise missiles and vice versa. ROE and other doctrine are being updated accordingly. In the same manner, a mobile, intelligent, and controllable AUWS is closer to the definition of a submarine than a mine. ROE may need to be updated to clarify this ambiguity.³⁹

2.4.3 International Maritime Law

“International law and practice regulate the use of the seas, each nation’s rights regarding its national territory and waters, the initiation and conduct of armed conflict, and limitations regarding employment and types of weapons.”⁴⁰

Mining operations are considered by the international community to be acts of war unless they are conducted as a protective measure within a nation’s coastal waters. Proper notifications to commercial shipping must be made in order to prevent unintentional damage or destruction to vessels transiting affected waterways.

The Hague Convention (VIII) of 1907 set forth several international laws that are still in effect today regarding the use of sea mines. Here are the specific provisions outlined:⁴¹

- Armed, unanchored mines must have a maximum life of 1 hour
- Armed, anchored mines must become unarmed if they break free from their moorings
- Mines must be designed to become harmless should they miss their target
- It is illegal to mine solely against commercial shipping
- Neutral nations are not to be interfered with, and the safe transit of neutral shipping must be ensured
- Mines must be removed by the planting force at the conclusion of hostilities

Although, the United States did not ratify the Hague Convention, the restrictions and principles laid forth have always been abided by.

39 Singer, P.W. Personal interview. 15 Mar. 2011.

40 Joint Chiefs of Staff. JP 3-15: Joint Doctrine for Barriers, Obstacles, and Mine Warfare. Washington, D.C.: Joint Chiefs of Staff, 1999. I-V.

41 Hague Conference of 1907. "Avalon Project - The Laws of War." 18 Oct. 1907. *Yale.edu*. 22 Apr. 2011. <http://avalon.law.yale.edu/subject_menus/lawwar.asp>.

Another treaty of note is the Seabed Arms Control Treaty of 1971. This treaty prohibits the use of tethered weapons of mass destruction outside of the 12 nautical mile coastal region. This includes the use of both bottom and moored mines.⁴²

In all cases it is important the Navy fully understands the laws that govern the use of mines and other undersea weapons, as they will influence the development of AUWS. More importantly, AUWS will likely have an impact on international law. For example, the use of unrestricted submarine warfare by Germany in World War I led to the United States, Britain, Japan, France, and Italy signing agreements essentially making this tactic illegal. The agreements required submarines to surface and provide a safe place for crews before attacking merchants. In fact, unrestricted submarine warfare was the justification for US entry into the war. Yet, less than three decades later, the United States Navy itself used this tactic against the Japanese in World War II, with almost no debate.⁴³ History is filled with examples of technology driving international law. As technology continues to advance, and more and more countries begin to embrace the concept of weaponized unmanned undersea systems, the United States and the international community may need to reassess this particular area of maritime law.

2.5 Specific Areas of Need

The areas, or categories, of need for AUWS shown in Figure 2.6 are developed from the input of stakeholders, the future challenges facing USW forces, a preliminary operational concept, and other issues that may impact the system. These needs are not prioritized relative to each other. Rather, they are all deemed the most relevant and warrant further refinement into top level requirements.

42 Russian Federation, United Kingdom of Great Britain and Northern Ireland and United States of America.

"Treaty on the Prohibition of the Emplacement of Nuclear Weapons and Other Weapons of Mass Destruction on the Sea-bed and the Ocean Floor and in Subsoil Thereof (Seabed Treaty)." 11 Feb. 1971. *NTI.org*. 22 Apr. 2011.

43 Singer, P.W. Personal interview. 15 Mar. 2011.



Figure 2.6: Specific Areas of Need for AUWS

- **Threat Discrimination:** AUWS must be capable of identifying threats from normal vessel traffic. AUWS should utilize sensor data, such as visual and acoustic signatures, and target behavior, such as speed and maneuvering, to determine hostile identity and/or hostile intent. The balance between probability of false positive (i.e. friendly/neutral identified as threat) and probability of false negative (i.e. threat identified as friendly/neutral) should be adjusted according to the specific mission and consequences of each type of error. Threat discrimination is recognized as one of the most difficult challenges facing the development of AUWS.
- **Detection Avoidance:** AUWS must minimize detectable signals from the following categories: acoustic emission, RF emission, IR emission, visible contrast/reflectance, RCS, magnetic anomalies, and laser cross section among others. Mobility to evade an enemy or a neutral, such as a trawling vessel, is highly desirable. In this context, detection avoidance also encompasses other types of security. AUWS must avoid the

compromise of sensitive information, advanced technology, and dangerous weapons either through self-destruction or returning to base upon mission completion.

- **Adjustable Autonomy:** An AUWS operator must be able to designate the level of autonomy as a function of operational phase, tactical situation, current mission, and availability of communications. Level of autonomy will generally form a trade space with discrimination and communication. Highly autonomous modes will require less communications with an operator but will incur greater risk of discrimination error, and vice versa.
- **Persistent Forward Presence:** AUWS must have an endurance of no less than 30 days, including deployment, operations, and recovery. Aside from being a stated CNO goal, this level of endurance is commensurate with reasonable logistics support (e.g. maintenance, re-seeding, etc.) for area denial missions. Endurance must be coupled with independence from tending vessels in order to bring a unique capability to the USW force. This area is a significant technological challenge, but one that is currently receiving much attention from stakeholders in all categories.
- **Enemy Prosecution (manned and unmanned):** AUWS must harness the capability to engage designated maritime targets in order to neutralize threat platform mission effectiveness (i.e. mission kill). Neutralization should occur by means of kinetic assault. Such neutralization is limited by target survivability, which is a function of susceptibility, vulnerability, and recoverability. AUWS should be capable of engaging unmanned systems, ranging from mines and torpedoes to enemy versions of AUWS.
- **Operational Picture Development:** AUWS must have the capability to transmit information about its area of responsibility to decision makers in a tactically relevant timeline. Since AUWS can operate autonomously, it must be able to not only contribute to the combined operational picture but also develop an internal operational picture of its own. Therefore, it must process sensor data into tactical information within its local network. This need drives the requirement for sensors, communicators, and processors. Undersea communication at long range with minimal time latency and high data rates is a significant technological challenge.

- **Platform Independence:** AUWS must be capable of deployment and recovery from multiple platform types found in the United States military inventory. Surface ships should be able to deploy units over the side, aircraft should be able to drop units from altitudes commensurate with mission requirements based on airframe safety parameters, and submarines should be able to deploy units from either torpedo tubes or lock-out trunks. Surface ships should be able to recover units either via davits or well decks and submarines should be able to recover units in the same manner they were deployed. This need does not imply that AUWS must be capable of deployment and recovery from all platforms in the United States Navy inventory. Rather, it is critical to avoid relying on a single platform or allowing any platform to assume a central role in mission accomplishment.

3. Functional Analysis and Allocation

3.1 Functional Analysis

A robust functional analysis allows the development of meaningful physical alternatives and provides a traceability to ensure that any considered alternative performs the necessary functions to meet mission requirements. The specific functions that define the conduct of the AUWS mission are derived from the key areas of need identified from Needs Analysis. Those top level functions are decomposed into sub-functions to determine what, and how many, physical elements would be necessary for sufficient performance. Measures of effectiveness (MOEs) and measures of performance (MOPs) are mapped to functions and sub-functions, further contributing to traceability to stakeholder requirements. An analysis of functional flow is also considered to determine potential interactions between functions. Functional analysis gives insight into which functions are more critical than others, aiding the allocation and alternative generation processes.

At each step in the process, the previous steps are re-evaluated to ensure that sufficient granularity exists. The constant review of previous products against new products results in the creation of a refined overall input/output description of the system and a robust definition of the connections within the system. This thorough analysis allows one to map functions and sub-functions to physical architectures and functional connections to interfaces such that the actual utility of a physical concept can be identified.

3.1.1 Functional Mapping

Table 3.1 maps functions to each need area.

Table 3.1: Functional Need Traceability

Need Area	Function
Threat Discrimination	Perform ISR
Detection Avoidance	Provide OPSEC
Adjustable Autonomy	Perform C3
Persistent Forward Presence	Provide Power, Perform C3
Enemy Prosecution (manned and unmanned)	Prosecute, Perform C3
Operational Picture Development	Perform ISR, Perform C3
Platform Independence	Maneuver, Perform C3

From this mapping, six top level functions are identified:

1. Provide Power
2. Maneuver
3. Perform Intelligence, Surveillance, and Reconnaissance (ISR)
4. Perform Command, Control, and Communication (C3)
5. Prosecute
6. Provide Operational Security (OPSEC)

A seventh function, “Provide Structure,” exists that defines the need for a physical construct that houses the components that perform the constituent functions. Together, these seven functions define the conduct of AUWS operations as desired by stakeholders.

3.1.2 Functional Decomposition

Figure 3.1 shows the top level functional decomposition defined by the necessary functions. All functions are equally valued in terms of the functional hierarchy and are denoted by a “1.X”. The flow and interrelation of the seven functions will be further explored, but a complete function-by-function decomposition must be performed first. Relevant MOEs and MOPs are described with each function and sub-function. A full list of MOEs and MOPs considered can be found in Appendix C.

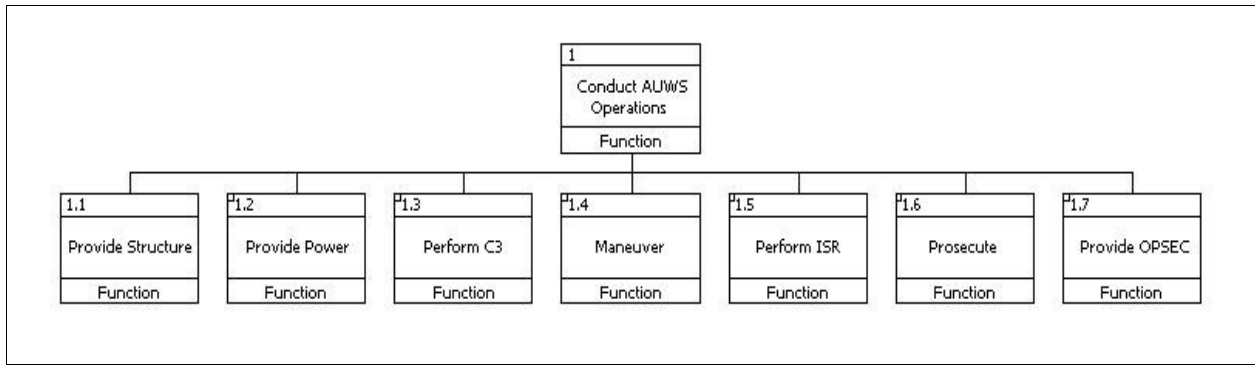

Figure 3.1: AUWS Top Level Functional Decomposition

3.1.2.1 Provide Structure

Function 1.1, Provide Structure, refers to the need to provide a physical architecture for the system’s components and therefore feeds into every other function. While this function is not decomposed into detailed sub-functions, it is important to consider because it serves as a transition for the functional allocation and alternative generation processes. Every AUWS function must be performed by a physical element, which must be integrated with all other physical elements into a cohesive architecture. While it is important to recognize the difference between the physical and the functional, the function of providing physical structure cannot be ignored. MOEs associated with this function are the capability to house physical elements for each function without adversely affecting performance of other functions, and the capability to integrate physical elements.

3.1.2.2 Provide Power

AUWS must have an operational endurance of no less than thirty days. This includes stored energy requirements, recharge requirements, and the power distribution requirements to operate independently of a manned asset. The power requirements encompass deployment, on-station, and recovery operations. Periods of loitering, patrolling, and sprinting must be considered.

Function 1.2 provides power of some form to all components within AUWS. Nearly every function and sub-function requires power of some sort. To provide power, certain sub-functions covering required capabilities must exist:

- The ability to receive power of some form from both internal and external sources (Function 1.2.1).
- The ability to store that received power in some medium for later retrieval (Function 1.2.2).
- The ability to manage power reserves and determine appropriate action based on capacity and component power draw (Function 1.2.3).
- The ability to distribute power (Function 1.2.4) based on power management inputs such that power allocation is adjusted (Function 1.2.4.1) or maintained (Function 1.2.4.2).
- The ability to control the generation of power internally (Function 1.2.5) using onboard re-charging elements (Function 1.2.5.1) or not (Function 1.2.5.2).

Given these requirements, the complete functional decomposition for Function 1.2 is displayed in Figure 3.2. Without addressing functional flow, the need for binary, or “on/off,” sub-functions (Functions 1.2.4.1/2 and 1.2.5.1/2) may not be readily apparent, but when analyzed from a logical AND/OR process it follows that power distribution will either remain constant or change and power will either be generated or it will not. This is further discussed during the Functional Flow portion of the functional analysis.

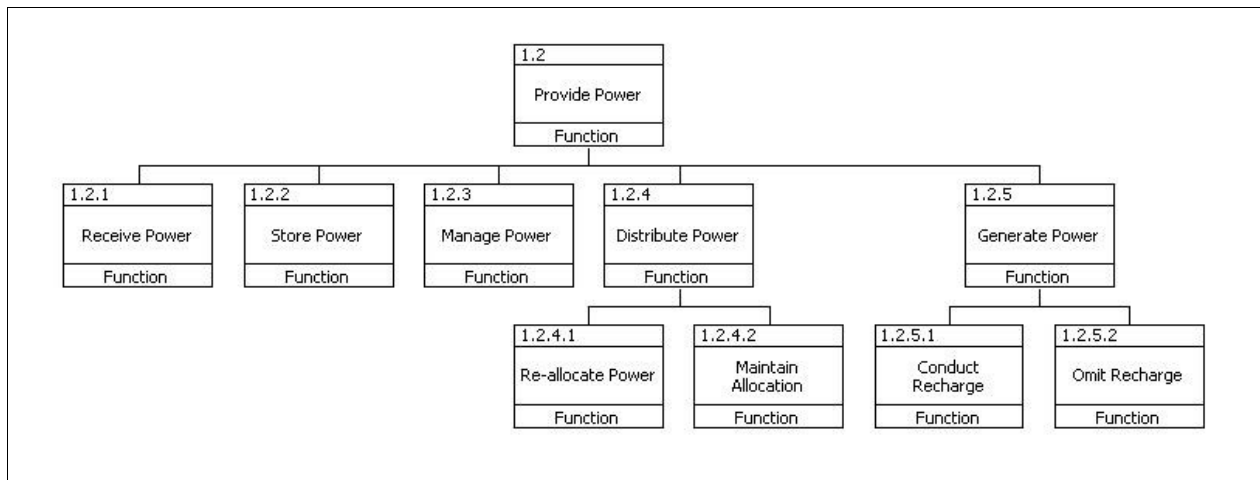

Figure 3.2: Provide Power Functional Decomposition

MOEs associated with this function are: the capability to operate for the required time frame of 30 days; capability to recharge; and the capability and capacity to store energy.

3.1.2.3 Perform C3

AUWS operators must be able to designate level of autonomy as a function of operational phase, tactical situation, current mission, and availability of communications. The levels of autonomy range from total man-in-the-loop control to fully autonomous operations. On-board processing power aids in the ability for AUWS to operate effectively. Additionally, AUWS should have the capability to transmit a near real-time picture of an area of interest to decision makers. MOEs associated with this function are: the probability of successful command automation; the capability to change the level of autonomy; and the capability to communicate (receive and transmit) messages.

The performance of a C3 function is more complex than a power provision function, such that C3 must be discussed in a tiered fashion. Figure 3.3 shows the three primary sub-functions of the C3 function, Command, Control, and Communicate.

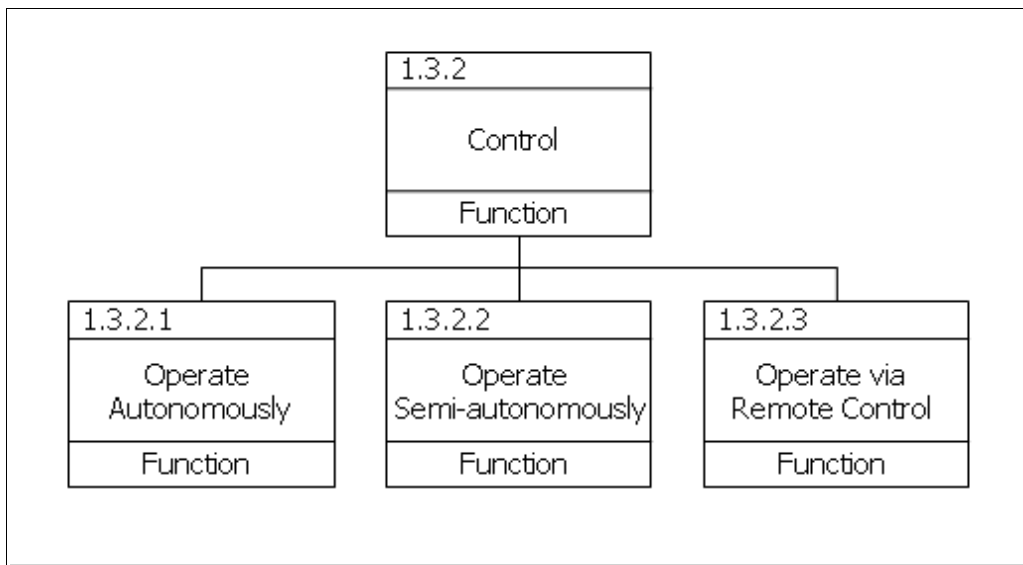

Figure 3.3: Perform C3 Functional Decomposition

Decomposing Function 1.3.1, Figure 3.4 shows the hierarchy of the Command function. Command, in the broadest sense, is concerned with the receipt of orders (Function 1.3.1.1), the evaluation of overall system status for the purposes of determining feasible responses (Function 1.3.1.2), the evaluation of sensor data to determine appropriate action (Function 1.3.1.3), the analysis of the specific order (Function 1.3.1.4), and the execution of that order (Function 1.3.1.5).

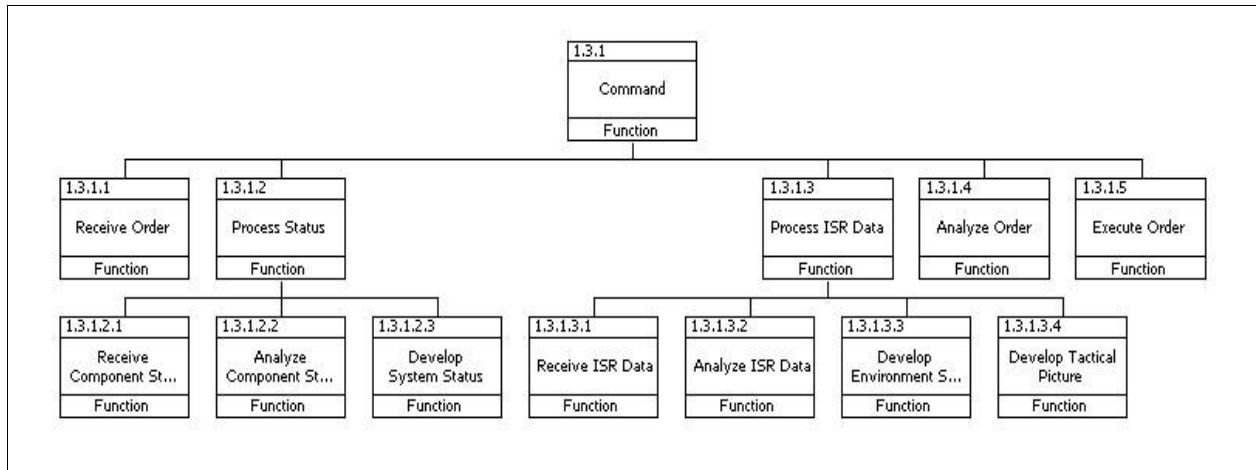

Figure 3.4: Command Functional Decomposition

Expounding upon the Function 1.3.1.2, the processing of System Status, there are three sub-functions to consider: the receipt of component status reports (Function 1.3.1.2.1) with regard to power, functionality, armament, positioning, visibility, and readiness; the analysis of those component status reports (Function 1.3.1.2.2); and the fusing of that data into a comprehensive evaluation of overall system readiness (Function 1.3.1.2.3). This system status will be used to constrain actions in response to orders or programming, as well as provide manned assets with system health and battle damage assessments (BDA).

Function 1.3.1.3, Process ISR Data, is similar in that it consists of sub-functions for the receipt of ISR data from system sensor suites (Function 1.3.1.3.1) and the analysis of that ISR data (Function 1.3.1.3.2). Analyzed data is used to simultaneously develop an environmental status for the operational area (Function 1.3.1.3.3) and a tactical picture of the operational area (Function 1.3.1.3.4). The environmental and tactical pictures will be used to determine appropriate system response to orders and programming, and will also be transmitted to manned assets to improve the Combined Operational Picture for the Operational Commander.

Figure 3.5 shows the functional decomposition of the Control Function (Function 1.3.2).

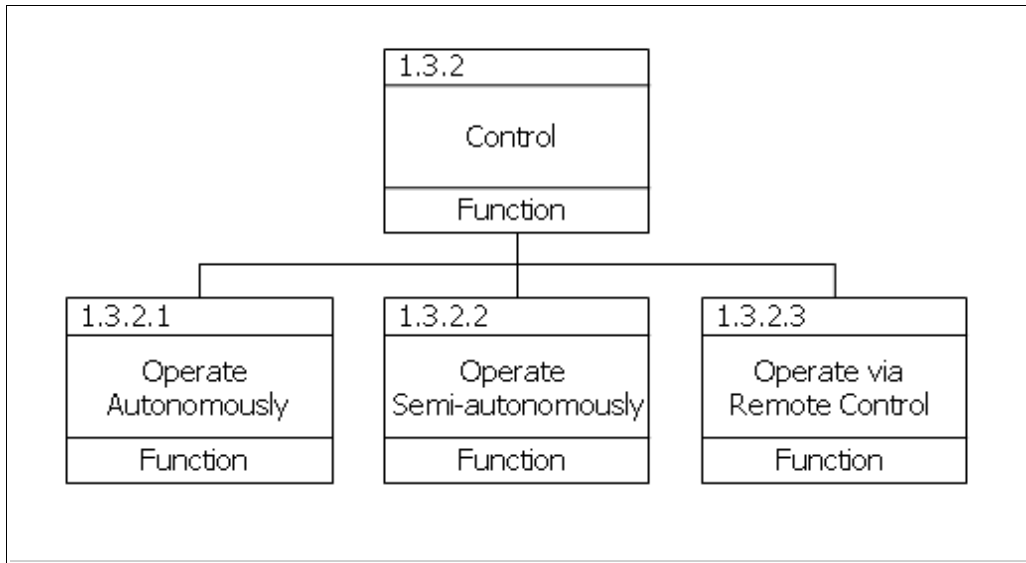

Figure 3.5: Control Functional Decomposition

The Control Function determines the autonomy status of AUWS, which is presented for ease of analysis as full autonomous operation (Function 1.3.2.1), semi-autonomous operation (Function 1.3.2.2), and full remote manual control (Function 1.3.2.3). In further analysis, semi-autonomous operation could be decomposed into several gradations. A more detailed approach might resemble the taxonomy used by ONR for UAVs, shown in Table 3.2.⁴⁴

⁴⁴ Button, R. W., J. Kamp, T. B. Curtin, and J. Dryden. A Survey of Missions for Unmanned Undersea Vehicles. Santa Monica: RAND Corporation, 2009. 64-65.

Table 3.2: ONR Levels of Autonomy for UAVs

Fully Autonomous	The system requires no human intervention to perform any of the designed activities across all planned ranges of environmental conditions.
Mixed Initiative	Both the human and the system can initiate behaviors based on sensed data. The system can coordinate its behavior with the human's behaviors both explicitly and implicitly. The human can understand the behaviors of the system in the same way that he or she understands his or her own behaviors. A variety of means is provided to regulate the authority of the system with respect to human operators.
Human-Supervised	The system can perform a wide variety of activities once given top-level permissions or direction by a human. The system provides sufficient insight into its internal operations and behaviors that it can be understood by its human supervisor and appropriately redirected. The system cannot self-initiate behaviors that are not within the scope of its current directed tasks.
Human-Delegated	The system can perform limited control activity on a delegated basis. This level encompasses automatic flight controls, engine controls, and other low-level automation that must be activated or deactivated by a human and act in mutual exclusion with human operation.
Human-Assisted	The system can perform activities in parallel with human input, thereby augmenting the ability of the human to perform the desired activities. However, the system has no ability to act without accompanying human input.
Human-Operated	All activity within the system is the direct result of human-initiated control inputs. The system has no autonomous control of its environment, although it may be capable of information-only responses to sensed data.

The Control function takes user input, programming, and mission profile into account to select autonomy mode and adjusts configuration accordingly, which then has an effect on all other aspects of AUWS operations.

Figure 3.6 shows the functional decomposition of the final sub-function of C3, Communicate (Function 1.3.3), which consists of the receipt of communications (Function 1.3.3.1) external to the system or external to the node, the distribution of that data (Function 1.3.3.2) to appropriate systems or components and the transmission of data either externally (Function 1.3.3.3) or internally (Function 1.3.3.4). An important MOP for this sub-function is the average data message completion time (MCT), which is essentially the time it takes to communicate a message externally.

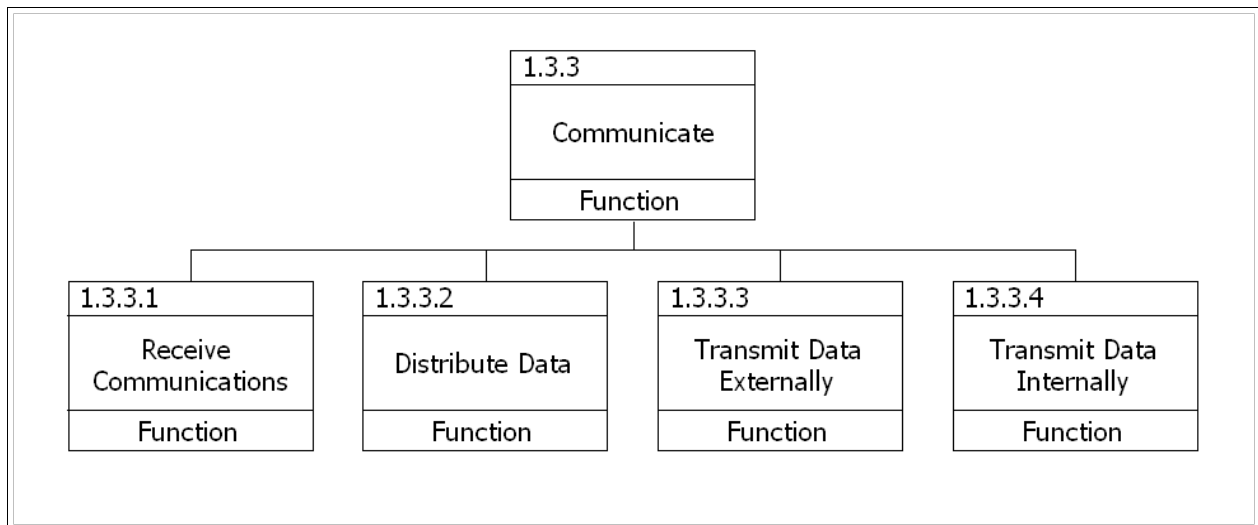

Figure 3.6: Communicate Functional Decomposition

3.1.2.4 Maneuver

Maneuverability for AUWS encompasses deployment, employment, and recovery. The system must be capable of being launched from a safe distance, deliver itself to the mission area, and relocate as necessary. Movement during operation may or may not be required. Due to the diminishing nature of the defense budget, AUWS should be reusable when feasible or expendable if unit cost can be held low enough. In order to be reusable AUWS must be recoverable by a surfaced or submerged platform operating in the area. The system should be able to return to a safe location for recovery when required by recovery platform. Expendable systems that cannot perform the recovery function are also considered.

Figure 3.7 shows the four sub-functions that describe AUWS' ability to maneuver. AUWS should maneuver in a manner by which the system has the a functional capability to deploy (Function 1.4.1) either on its own or with the assistance of another asset, i.e. self-contained propulsion system for transit to operational area vice air drop over operational area. Further, the system, once in the operational area, should be able to conduct its patrol (Function 1.4.2) in whatever mission profile it is assigned or whatever mission profile the systems deems appropriate based on situational awareness described by the Command function. AUWS should have a Navigate function (Function 1.4.3) that defines its ability to self-locate and move accordingly in support of mission accomplishment. Finally, AUWS should be capable of

recovery (Function 1.4.4) of some kind such that a field of undersea weapons is not left on station beyond the desired operational period. MOEs associated with the Maneuver function include the probability of surviving deployment and recovery, the capability to maneuver on patrol, and the capability for autonomous or semi-autonomous recovery.

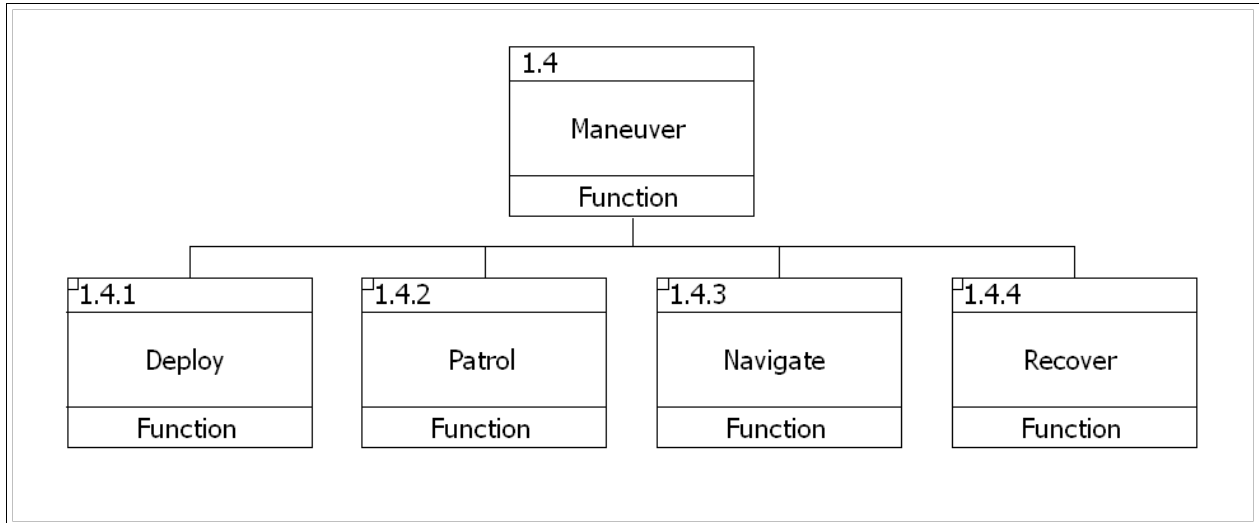

Figure 3.7: Maneuver Functional Decomposition

Figure 3.8 shows the breakdown of the Deploy function. This function covers the deployment of AUWS from multiple platforms in support of the need for a non-platform centric design. While not specifying the specific mode of launch (torpedo tube launch, artillery launch, air drop, etc.), it is desirable that any physical architectures be designed to accommodate deployment from a submerged asset (Function 1.4.1.1), including submarines and/or UUVs, a majority of surface combatants (Function 1.4.1.2), airborne platforms (Function 1.4.1.3) capable of air drop, and shore installations (Function 1.4.1.4).

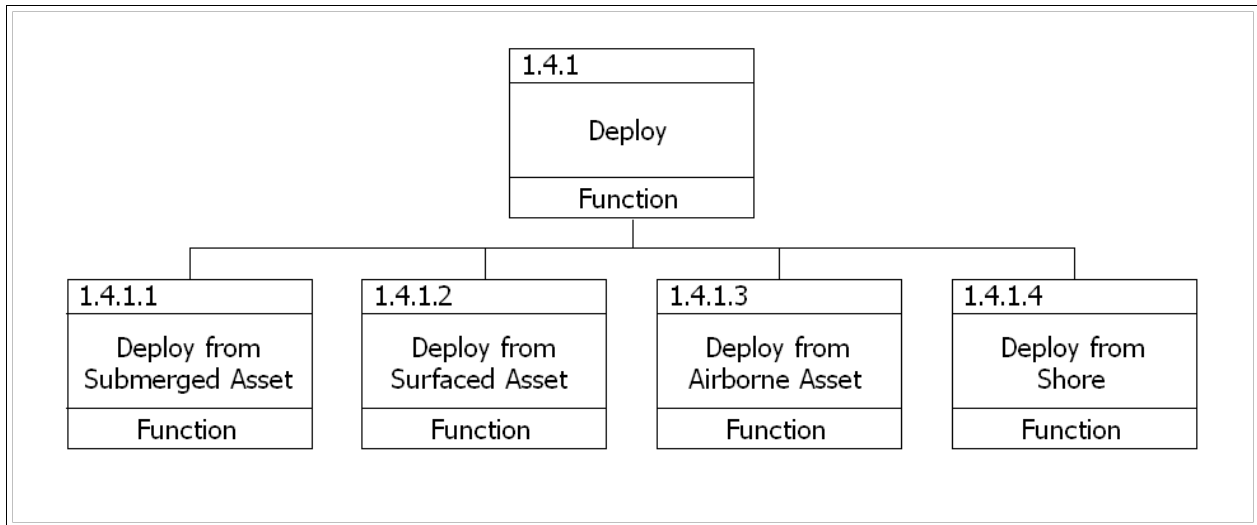

Figure 3.8: Deploy Functional Decomposition

As shown in Figure 3.9, the Patrol function covers the maneuver capabilities required from the moment of deployment to the moment of recovery (or neutralization), covering inbound and outbound transit (Function 1.4.2.4) and operations while on station. Depending on physical architecture and mission profile, on station maneuver may include Loitering (Function 1.4.2.1), Roving (Function 1.4.2.2) and Sprinting (Function 1.4.2.3). Should the need arise, transit may also be required for relocating AUWS to new operating area, such as the entrance to a port.

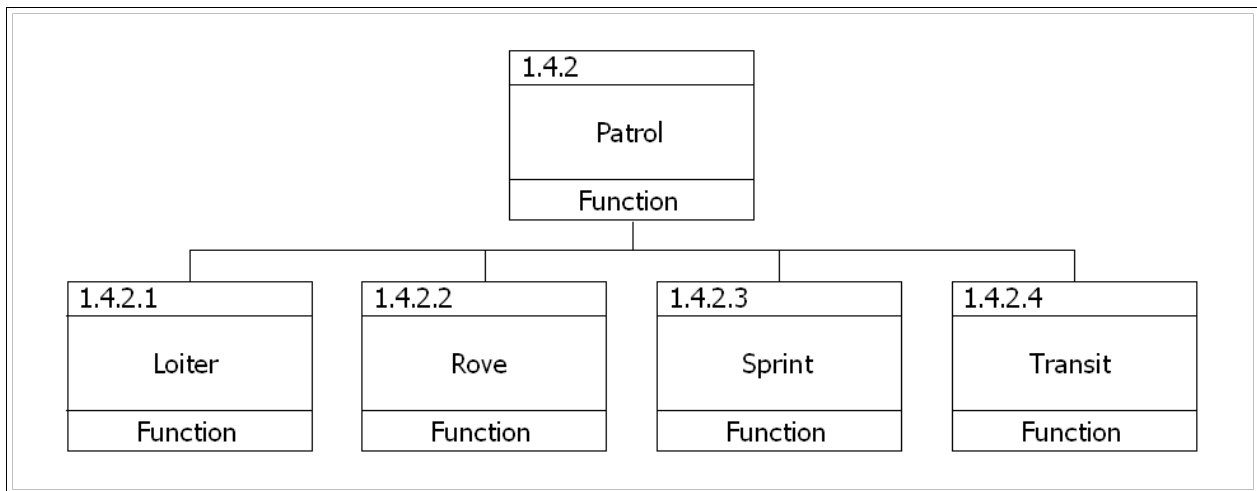

Figure 3.9: Patrol Functional Decomposition

The Navigate function (Function 1.4.3) covers the specifics of the system's navigational tasks so as to accomplish the other Maneuver sub-functions. From Figure 3.10, navigation

consists of determining self-location (Function 1.4.3.1), providing propulsion (Function 1.4.3.2), and steering (Function 1.4.3.3).

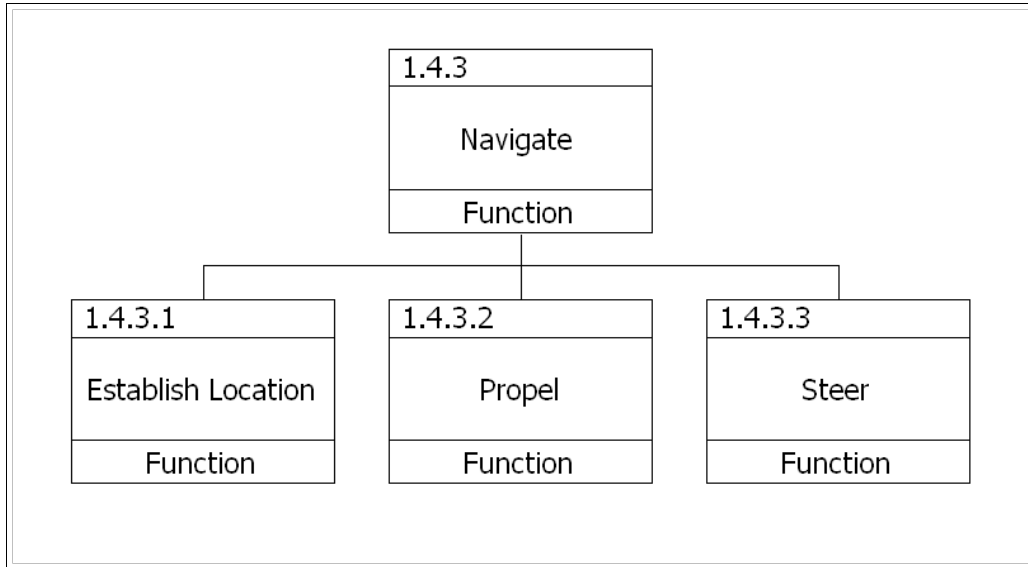

Figure 3.10: Navigate Functional Decomposition

The Recover function (Function 1.4.4) is defined by the system’s ability to cease operations as an active warfare system either by physical recovery or by self-neutralization. Figure 3.11 shows the use of submerged (Function 1.4.4.1) and surface (Function 1.4.4.2) assets to recover AUWS, or the use of a Scuttle function (Function 1.4.4.3) to self-neutralize.

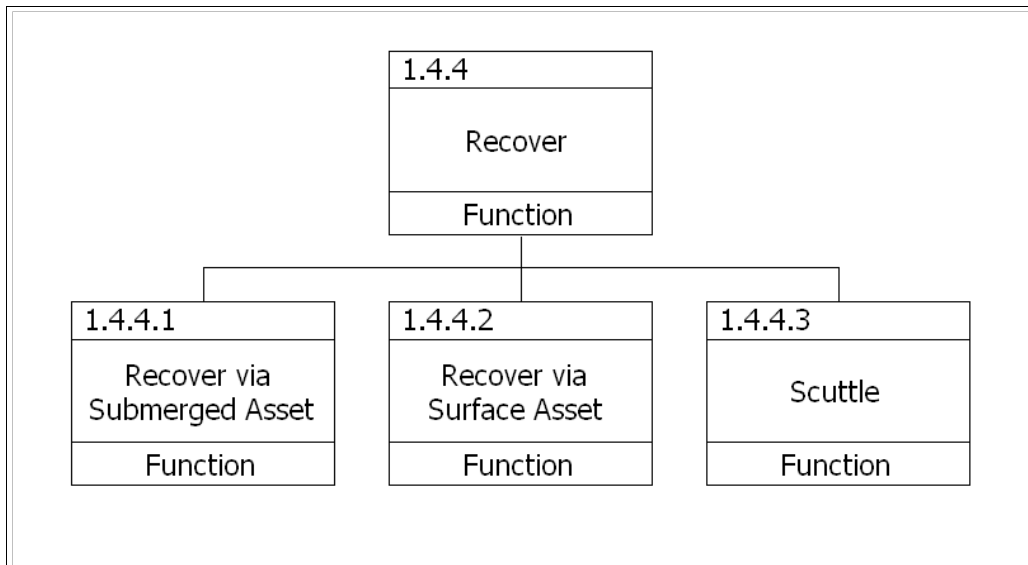

Figure 3.11: Recover Functional Decomposition

3.1.2.5 Perform ISR

One of the fundamental purposes of AUWS is the ability to provide timely, accurate situational awareness via a robust sensor suite. With the possibility of being placed in the world's busiest ports or straits, AUWS must have the capacity to handle significant peak vessel traffic. AUWS must be able to correctly establish its environment, conduct searches, detect and identify threats from the entire operational picture, track those threats, and accurately classify targets. MOEs associated with ISR include: the probability of location accuracy; probabilities of correct target detection, recognition, prioritization, and classification; and the capability to develop situational intelligence.

From Figure 3.12, the tactical picture is developed by the Search (Function 1.5.1), Detect (Function 1.5.2), Track (Function 1.5.3), and Classify (Function 1.5.4) functions, wherein every received sensor signature is analyzed for movement, localized, classified, and discriminated into environmental activity, organics, contacts, contacts of interest, and threats. The fifth and final function is Intelligence Collection (Function 1.5.5). Intelligence Collection is the means of collecting reconnaissance data beyond simple tactical positioning, consisting of acoustic intelligence (Function 1.5.5.1), communications intelligence (Function 1.5.5.2), signals intelligence (Function 1.5.5.3), electronic intelligence (Function 1.5.5.4), and electro-optical and infrared (EO/IR) data (Function 1.5.5.5). Fusing these sub-functions together, an accurate environmental status and tactical picture can be formed which will benefit AUWS operations as well as the Operational Commander's overall situational awareness. An important MOP for ISR, which is used in modeling and simulation, is the proportion of detections to actual contacts present.

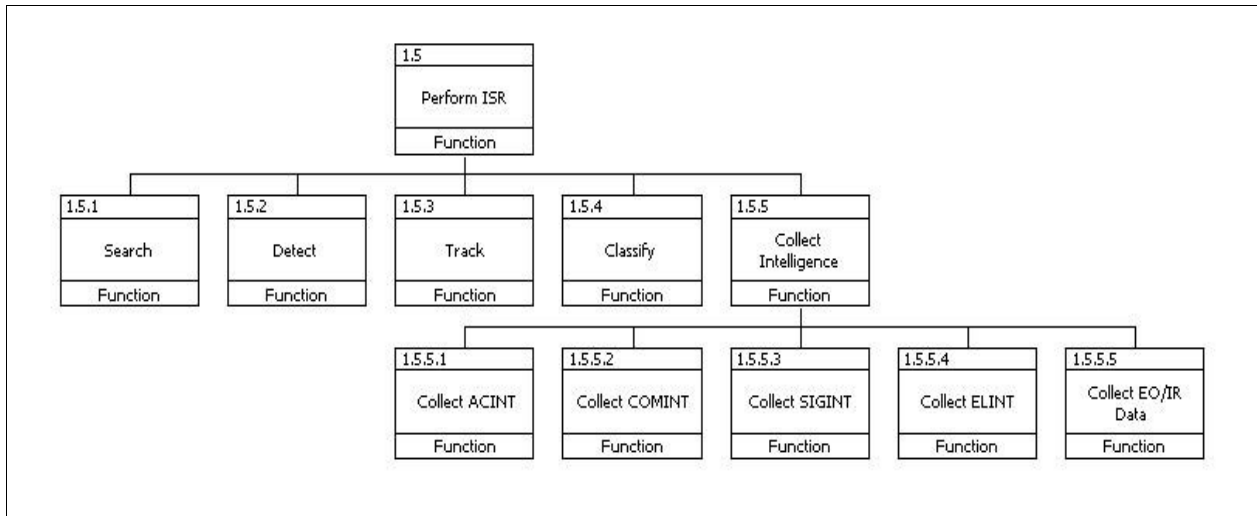

Figure 3.12: Perform ISR Functional Decomposition

3.1.2.6 Prosecute

AUWS must harness the capability to engage or deter designated maritime targets in order to neutralize threat platform mission effectiveness. The success of AUWS lies in its ability to effectively employ force to deter, damage, or destroy a target of interest as designated by the user or system within a specific period of time. Neutralization occurs by means of kinetic assault. Such neutralization is limited by target survivability, which is a function of susceptibility, vulnerability, and recoverability. Deterrence, on the other hand, occurs through the use of decoys or simply as a by-product of system employment resulting in the adversary altering operations.

A wide number of effectiveness measures can apply to AUWS prosecution. Much like a traditional mine field, the first engagement can cause a change in adversary operations, which significantly alters the initial probabilistic conditions. Therefore, an average or total number of threats killed over the entire mission duration is not necessarily indicative of true system performance. Occasionally, the probability of killing the first threat encountered or the expected number of kills for the first N threats are more appropriate MOEs. For the purposes of this analysis, the effectiveness of prosecution is measured by the proportion of threats killed to threats encountered on the first day of active engagement. To simplify the modeling and simulation effort, threat reaction to a successful prosecution is not modeled. Essentially, the model assumes that a few threat vessels will enter the operating area before they begin to take

evasive action. The reason for choosing this MOE is to give a common ground for comparison of all alternatives and to avoid yielding misleading results for systems that perform well initially but degrade quickly.

Figure 3.13 outlines the three primary types of engagement covered by the Prosecute function. Monitoring (Function 1.6.1) is the active, focused collection of data on a specific target for purposes of reconnaissance, early warning, or targeting. Deterrence (Function 1.6.2) is a functional description of a hold-at-risk or area-denial mission, wherein the perceived presence of AUWS will prevent free maneuver or local control of the seas for hostile contacts. The third and final sub-function engagement (Function 1.6.3) which is further delineated into the employment of non-lethal (Function 1.6.3.1) and lethal (Function 1.6.3.2) measures. In more specific terms, engagement can result in a mission kill by crippling critical threat systems (propulsion, weapons, damage control, etc.) or an asset kill (the sinking or destruction of the threat). The employment of non-lethal measures is particularly desirable for autonomous modes of operation because it mitigates risk. In other words, even if the probability of incorrect identifying a cruise liner as a threat is increased, the severity of the consequences is decreased dramatically.

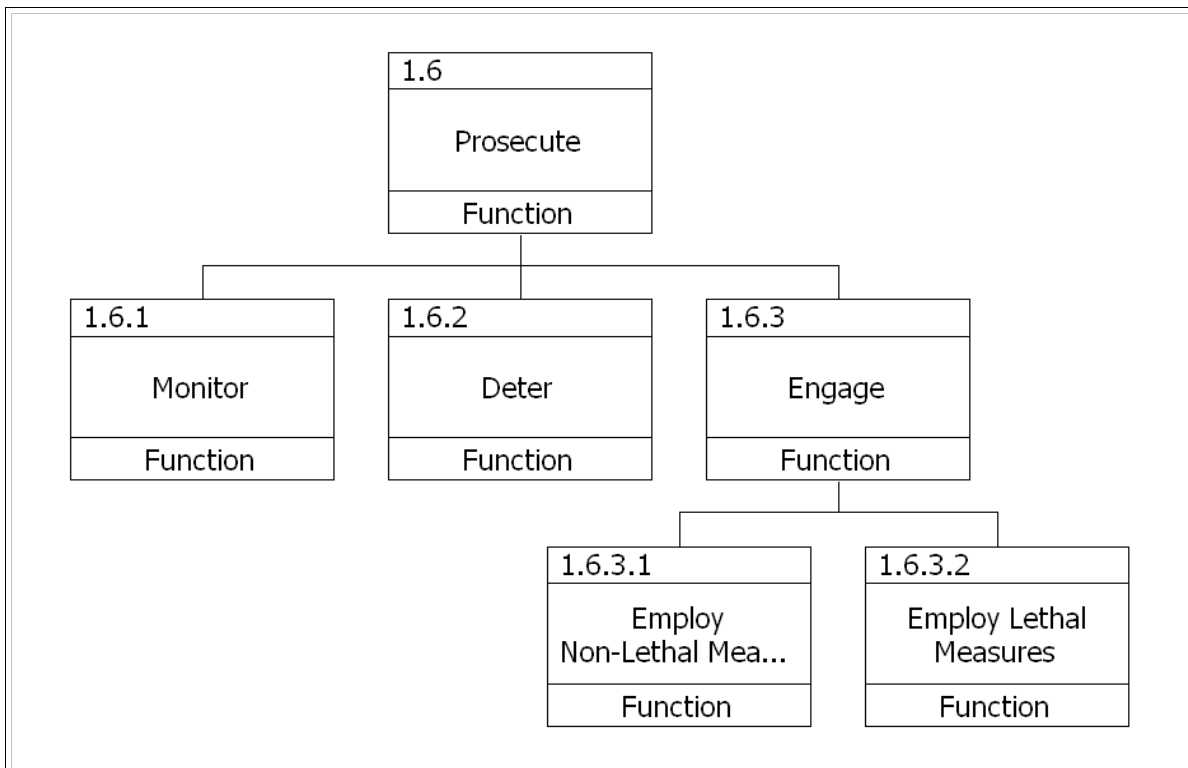

Figure 3.13: Prosecute Functional Decomposition

3.1.2.7 Provide OPSEC

Operational security includes the ability of the system to avoid detection by enemy sensors and, if detected, avoid capture and compromise. Detectable signals of interest include: acoustic emission, radio frequency (RF) emission, IR emission, visible contrast/reflectance, radar cross section (RCS), magnetic anomalies, and laser cross section. By minimizing these signals, AUWS can reduce observable signatures and thus operate more covertly. By changing operational modes (e.g. entering dormant mode) the system can minimize exploitation. If the risk factor to US vessels mitigates the feasibility of recovery or if AUWS falls into undesired hands, a self-neutralization feature will be triggered to ensure that sensitive hardware and software are not compromised.

Provide OPSEC is divided into two functions, detection avoidance (Function 1.7.1), and compromise avoidance (Function 1.7.2), as shown in Figure 3.14. MOEs associated with Provide OPSEC include the probability of detection avoidance and the capability to self-neutralize.

Detection avoidance is further broken down into passive and active measures. The passive measure, Provide emissions control (EMCON) (Function 1.7.1.1), is the effective management of emissions in RF, satellite, and acoustic spectrums to prevent detection by enemy assets. The active measure, changing operational posture (Function 1.7.1.2), is the change of operational activity to prevent detection by enemy assets.

In the event of successful detection and localization by enemy assets, the risk of compromise is minimized via evasive action (Function 1.7.2.1) including aggressive, radical maneuver and bottoming techniques, or the use of self-neutralization (Function 1.7.2.2), wherein onboard data is deleted, internal systems are destroyed, and the unit itself is scuttled in such a way that if debris is recovered, it will be devoid of any value to enemy assets. This sub-function is considered separate from the Scuttle function (Function 1.4.4.3) because it is performed in response to different stimuli. AUWS is scuttled when recovery is infeasible due to damage, power available, etc. whereas the system self-neutralizes when there is an imminent risk of compromise by the enemy.

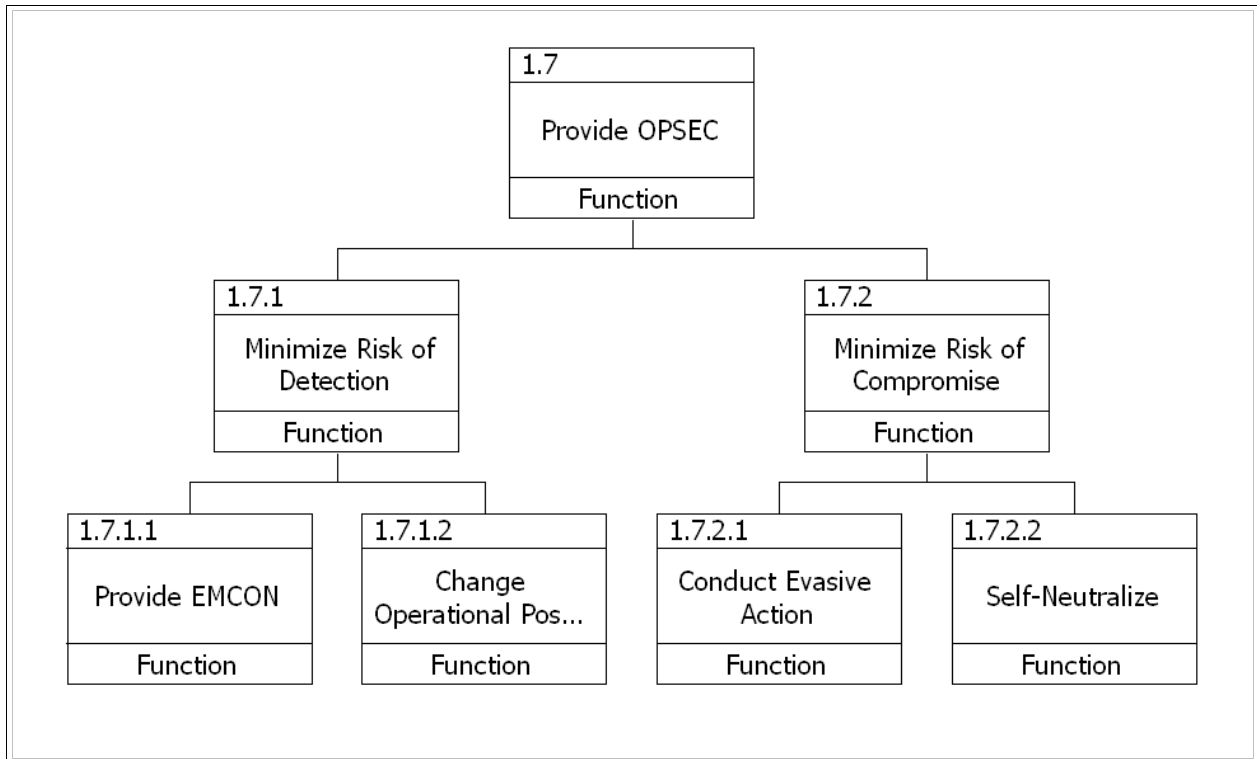

Figure 3.14: Provide OPSEC Functional Decomposition

3.1.3 Functional Flow

From the complete functional decomposition described in the previous section, a functional flow can be developed for each tier of the overall hierarchy. For a full review of the functional flow block diagrams (FFBD) and other diagrams associated with Functional Analysis, refer to Appendix D. Figure 3.15 shows the top level FFBD for AUWS. Viewing the flow of functions from left to right, it is apparent that any physical architecture must provide structure (Function 1.1) and power (Function 1.2) before any other functions may be addressed. From there, the remaining functions that define the actions undertaken by AUWS are performed in tandem, as signified by the AND logic. Only when Functions 1.3/4/5/6/7 are complete can the flow continue to the end of the process and outputs be produced.

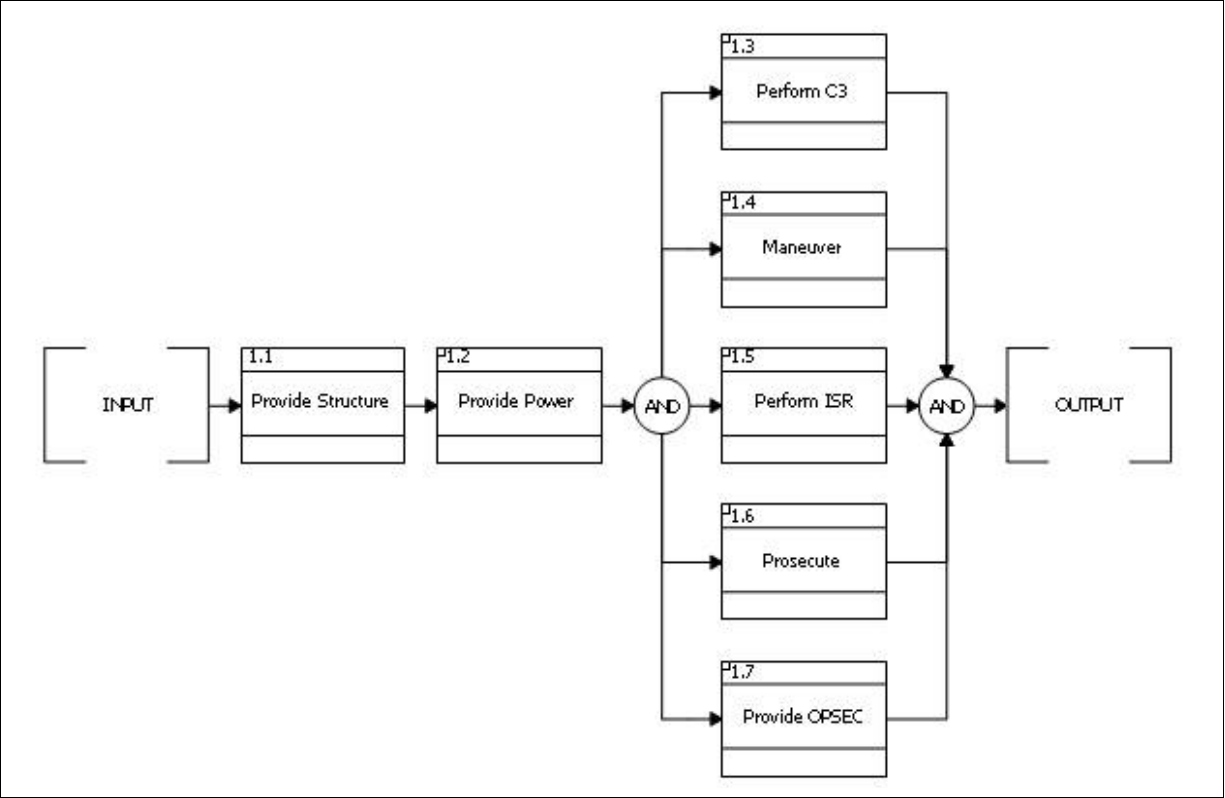

Figure 3.15: AUWS Functional Flow Block Diagram

Analyzing the functional flow from a higher level of abstraction leads to an input/output model for AUWS, as shown in Figure 3.16. This model considers not only the controllable inputs and intended outputs as discussed in functional decomposition, but also the uncontrollable inputs and unintended outputs (by-products) that may impact the system. The purpose of developing an input/output model is to give insight into which functions should be considered critical and how they might be allocated to physical elements.

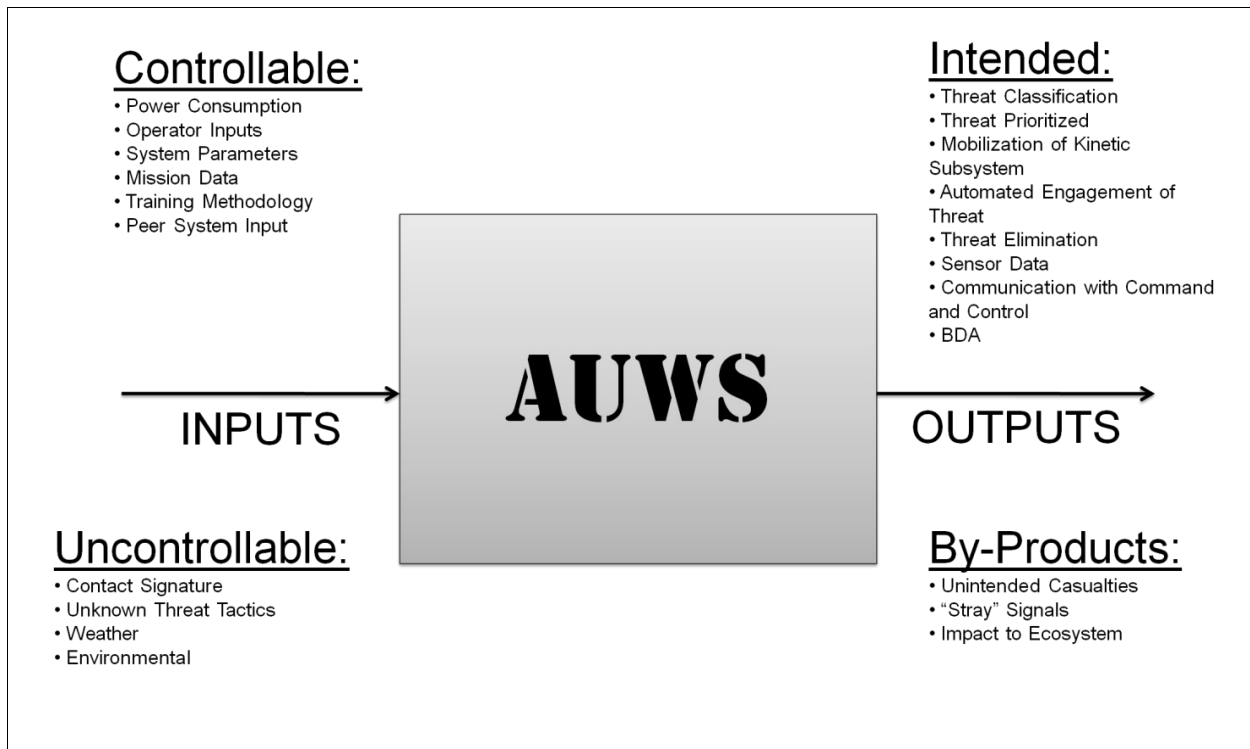

Figure 3.16: AUWS Input/Output Model

3.2 Functional Allocation

In an effort to ensure traceability from the physical architecture of AUWS to functional analysis, the primary functions are re-examined to determine which would have the most direct impact on the physical architecture. Tracing back to the original tasking document, it is obvious that providing an operational picture and engaging the enemy are of immediate interest. In order to accomplish this primary tasking, AUWS must be able to detect, communicate, and prosecute. The intended outputs from the I/O model validate these requirements. All of the intended outputs are directly related to these critical functions. Therefore, **sensors, communicators, and weapons** are deemed critical elements.

Other top level functions certainly have an impact on physical architecture, but they do not necessitate additional elements. For example, mobility can be addressed as a characteristic for a sensor, communicator, or weapon to satisfy maneuverability needs, but a separate vehicle need not be added to the system. Even if one considers the sub-system level, where some physical element must exist to provide propulsion, maneuverability is not required by initial

tasking. Only critical functions (and therefore critical elements) are considered mandatory. Non-critical functions are evaluated as part of trade space, so alternatives that do not perform some of these functions are considered.

Power generation is the lone exception in that it is a mandatory function that does require a physical element, such as a battery or an engine. Any power generating element, however, would only serve to support the critical elements in conducting their mission. In other words, an underwater diesel engine alone does not address any aspects of the AUWS problem statement or initial tasking. Providing enough power to sustain long term operations is recognized as one of the toughest technological challenges in the development of AUWS; however, the intent here is not to focus on the power issue at the expense of valuable operational analysis. System concepts are analyzed on the basis of power consumption and the capacity to store energy. It is assumed that all concepts will have equal access to the most beneficial technologies. Promising power generation technologies are researched and discussed separately.

3.2.1 Alternative Generation

Even after limiting the physical architecture to weapons, sensors, and communicators, there are still countless alternatives to be considered for AUWS. In order to establish a foundation for the alternative generation process, a dendritic model is used that enumerates different types of sensors, communicators, and weapons. The original dendritic model is then reduced by eliminating infeasible or low-potential branches and making some operational assumptions. The reduced model is used to generate preliminary concepts for physical architectures. From these preliminary concepts, four are selected for further analysis using a scoring and screening process. Design of Experiments is utilized to ensure the concepts effectively cover the design space and to validate the alternative generation process.

The original dendritic model is shown in Figure 3.17. Included in this model is any element type that could feasibly have utility for AUWS, based on research, operational experience, and first principles. It is apparent that two separate communicators are necessary to meet AUWS requirements, internal and external, and that multiple variations may be suitable for each. Internal communications would be short range between AUWS elements while external communications would be long range between AUWS and a command center or monitoring

asset. If AUWS contains one type of sensor, internal communicator, external communicator, and weapon, this model produces 3,136 possible architectures. If, however, AUWS contains one or more of each element, which is typical for redundancy or reliability purposes, over 1 billion⁴⁵ possibilities exist!

⁴⁵ This number is based on 7 sensors, 8 internal communicators, 8 external communicators, and 7 weapons; using one or more of each element. *Combinations Possible* = $2^7 * 2^8 * 2^8 * 2^7$

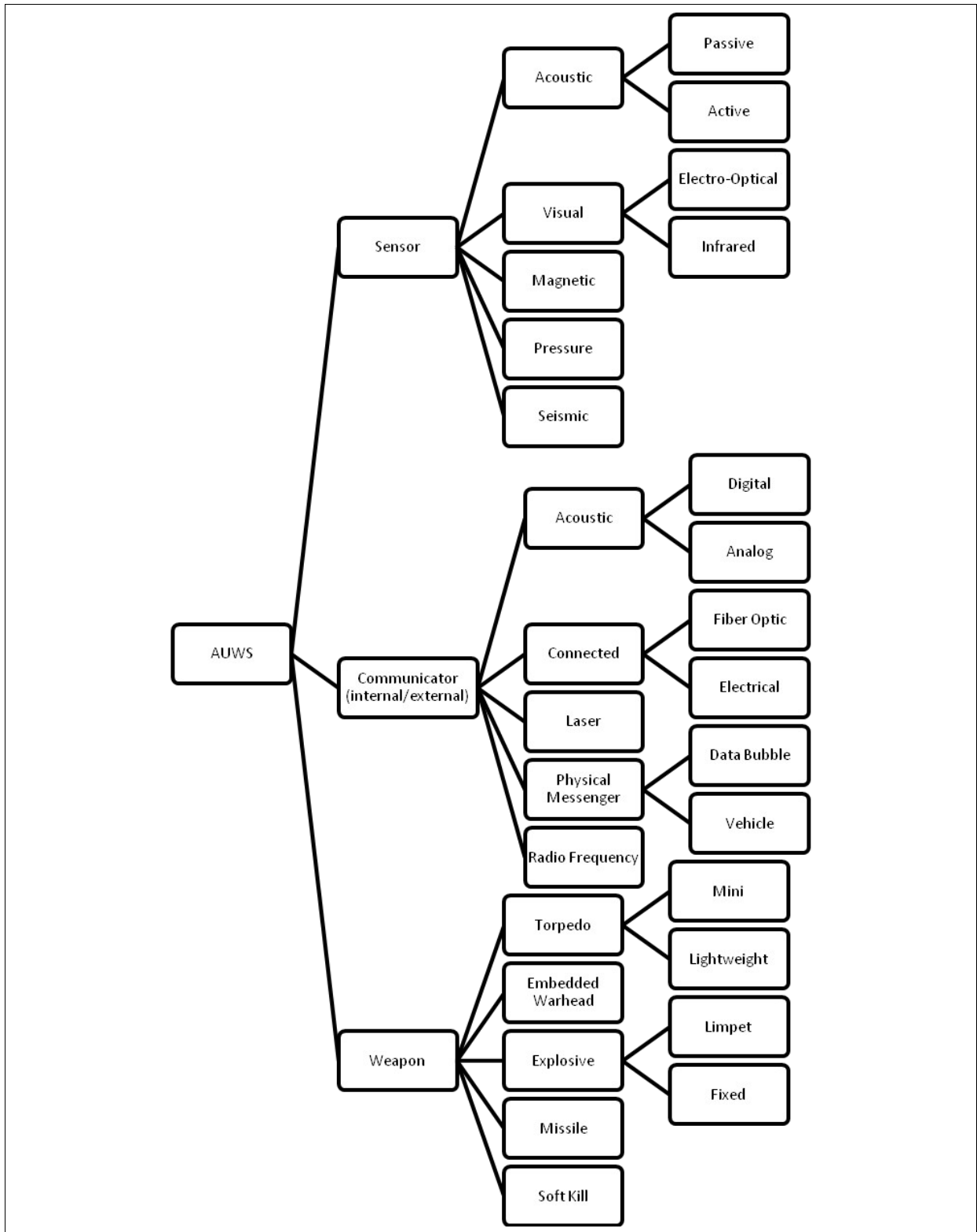

Figure 3.17: Original Dendritic Model

This model produces an unmanageable number of possible architectures. To aid elimination of infeasible or less promising options, the project team held an AUWS Warfare Innovation Workshop in December 2010. The workshop brought together NPS students from various nations and curricula, shown in Figure 3.18, for a week of innovation and generation of potential AUWS concepts and was vital to improving the original dendritic model. Several element types emerged as highly promising from the results of the workshop and were reinforced by independent research. It was also apparent that others were infeasible due to technological constraints or simply not meeting mission requirements. The most promising element types are included in the reduced dendritic model, shown in Figure 3.19. For a detailed review of the more promising technologies considered, refer to Appendix E.



Figure 3.18: Participants of AUWS Warfare Innovation Workshop

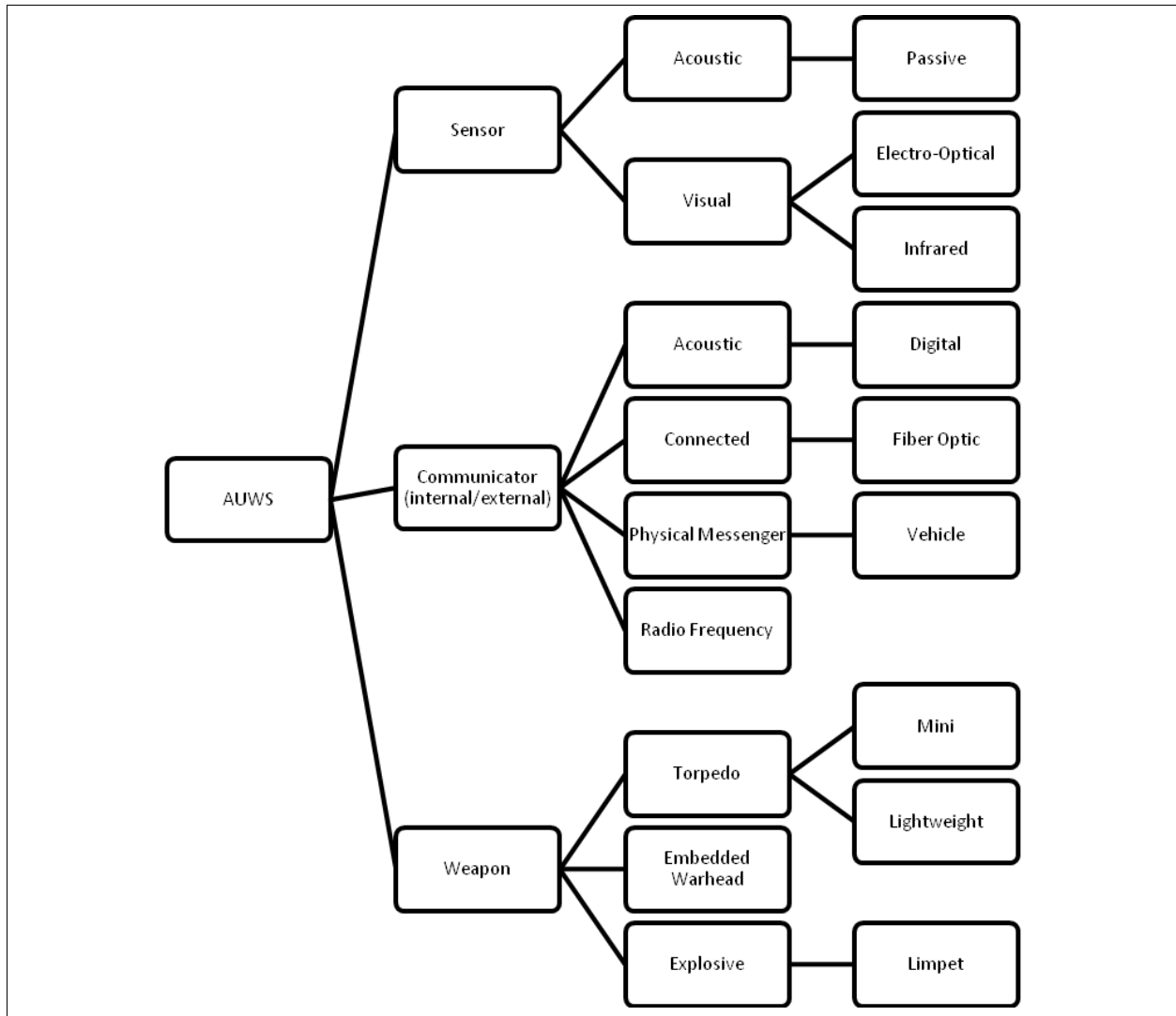

Figure 3.19: Reduced Dendritic Model

From this reduced model, there remain 32,768⁴⁶ possible architectures (assuming one or more of each element). In order to further reduce this number, several assumptions are made regarding the operation of AUWS, based on previous research and analysis.

- **Sensors:** It is common for EO and IR sensors to be combined together in a single unit, so they are regarded as a single element type. Furthermore, EO/IR sensors would not be ideally suited for underwater detection, so the only two possibilities considered are passive acoustic sensors with and without EO/IR sensors.

⁴⁶ This number is based on 3 sensors, 4 internal communicators, 4 external communicators, and 4 weapons; using one or more of each element. $Combinations\ Possible = 2^3 * 2^4 * 2^4 * 2^4$

- **Internal Communicators:** Physical messenger vehicles and RF communications are deemed infeasible for the purposes of communicating between AUWS elements, either due to time and power constraints or due to excessive exposure on the sea surface (i.e. AUWS elements would frequently need to surface to communicate with each other via RF due to its high attenuation in seawater).
- **External Communicators:** Digital acoustic communication and fiber optic cables are deemed infeasible for the purposes of communicating to an external network. Acoustic modems need significant technological advancement before they can communicate effectively at such long ranges and the large sound signature represents an OPSEC risk. For the various areas in which AUWS may be required to operate, deployment of hundreds of miles of fiber optic cable creates logistical requirements that outweigh the benefits of using AUWS in the first place. Physical messenger vehicles are only considered as a backup to RF communications.
- **Weapons:** Each potential architecture is limited to only one type of weapon. Redundancy and reliability could be achieved by distributing several of the same weapon type throughout the system. This method permits all four feasible weapons to be evaluated evenly and a decision whether to combine weapon types made. The Analysis of Alternatives includes a discussion regarding combination of weapons.

3.2.2 Preliminary Concept Development

With these assumptions in place, only 48 combinations are possible. Of these 48 potential physical architectures, seven preliminary concepts are developed. The goal in developing these concepts is to make them as disjoint as possible, thereby minimizing redundancy. The seven preliminary concepts developed are listed below.

- **Alternative 1:** This alternative consists of twin UUVs modeled after Mk48 ADCAP torpedoes. Units would be deployed from manned assets and then transit to the operational area. Once in the operational area the communications/ISR UUV would proceed with dispensing a network of sensor nodes from an internal storage bay. Once the network had been laid the unit would anchor to the sea floor and deploy a tethered RF communications and EO/IR sensor buoy, a cylindrical broadband sonar array, a

narrowband sonar strand array, and a recharging unit. The second UUV would deploy to the operational area and serve as a prosecution unit with onboard sub-munitions, such as lightweight torpedoes, which would either be distributed for later launch or launched via the primary unit. Additional variants could utilize onboard miniature UUVs to conduct ISR or larger warheads to function as self-guided torpedoes.

- **Alternative 2:** This alternative consists of a series of small, expendable devices that would serve as intelligence-collection, weapons, or communications nodes in a physically connected network that would cover a chokepoint in a surveillance net that would retain prosecution capability. Acoustic sensors and communicators are used within the network, and RF communications are used to exfiltrate data to a command center. Embedded warheads inside weapon nodes provide prosecution capability.
- **Alternative 3:** This alternative is a distributed network of identical weaponized acoustic sensor/communications nodes working in conjunction with a central gateway node. The basic unit is a small, non-recoverable node that would anchor to the sea floor. The gateway node would receive information from the local network and transmit externally via a RF communications buoy. Limpet explosives contained within the nodes would electro-magnetically attach to passing ships. These attached explosives are used to either destroy or deter passing craft by detonating on command via small communications receivers. By deactivating the ordnance, the system could mitigate the risk of collateral damage.
- **Alternative 4:** This alternative consists of a large diameter UUV teamed with torpedo-sized or smaller UUVs working together to collect intelligence and engage targets as needed. The larger size of the main unit would theoretically allow longer endurance and possible recharge capability while the smaller units would allow greater mobility. The smaller UUVs would establish a surveillance network via acoustic sensing and communications. They would prosecute targets by affixing limpet explosives to the hull. The main unit would serve as the gateway with a tethered RF communications antenna.
- **Alternative 5:** This alternative is an adaptation of Alternative 1 with a smaller form factor. This concept would utilize UUVs about the size of Mk-46 torpedoes in order to facilitate airborne delivery. Instead of lightweight torpedoes, this concept would utilize

mini torpedoes, such as the Compact Rapid Attack Weapon (CRAW), for prosecution. Additionally, this concept streamlines the number of variants in order to ensure capability among several Navy platforms while reducing overall costs. The implication is that this Alternative would necessitate more units than Alternative 1 to cover the same area.

- **Alternative 6:** This alternative consists of a large UUV that would deploy pairs of ocean floor sensor/communications nodes connected by fiber optic cables. Communications nodes would have acoustic modems for communicating between pairs. The UUV would deploy tethered a communications buoy that would provide surface ISR capability and serve as a communication gateway. The UUV would provide prosecution capability with externally mounted lightweight torpedoes. The UUV would be capable of self extraction and physically carrying information back to a command ship.
- **Alternative 7:** This alternative consists of a lightweight torpedo-sized UUV that would utilize undersea glider technology to patrol an area converting vertical into horizontal motion so as to minimize power draw and thereby increase endurance. The glider, while surfaced, would provide ISR and communications capability. Gliders would also utilize acoustic sensors and communications among each other. Prosecution would be accomplished by strategic positioning of gliders and detonation of an embedded warhead. Essentially, this concept is a homogeneous network of gliders with self contained sensors, communicators, and weapons.

3.2.3 Concept Narrowing

A scoring and screening process is used to reduce the set of alternatives down to a number that facilitates full system modeling and simulation for each concept. The goal is to select three to four concepts to model and analyze in detail.

3.2.3.1 Criteria

The functions and associated need areas for AUWS are used as criteria for narrowing of available concepts. Below are the judging criteria, as based on requirements and functional decomposition.

Power: This criterion is a representation of operational endurance in days, in available energy, energy consumption, and ability to operate independently of a manned asset. Those

systems with larger energy storage capacity coupled with energy efficient processes and recharge capability score higher marks than those systems without.

C3: This criterion is a representation of varying levels of autonomy, and is graded as the ability to provide both man-in-the-loop and autonomous operation. Systems with more onboard processing power balanced by more opportunities for human interface receive higher marks than simpler devices with no human input opportunities.

ISR: This criterion is a representation of the ability of a system to provide near-real time, accurate situational awareness via multiple sensor suites. Systems with broader range per deployed mission package and more robust sensor suites receive higher marks than those with a more limited range or less sensor redundancy.

Prosecution: This criterion represents the ability of the system to effectively bring force to deter, damage, or destroy a target of interest as designated by the user or system within a specific period of time. More versatile mission packages with larger overall explosive yield that could be employed rapidly receive high marks. Mission packages with limited maneuver capability and less overall firepower receive lower marks.

OPSEC: This criterion is a representation of the ability of the system to avoid detection by enemy sensors and, if detected, avoid capture and compromise. Systems with the ability to change operating modes or reduce observables receive higher marks than those that have more exploitable signatures or that cannot as readily evade or self-neutralize.

Maneuver: This criterion is a representation of the deployability, recoverability, and maneuverability of the system, or whether or not the system can be launched from a safe distance, deliver itself to the mission area, relocate if required, and return to a safe location for recovery as needed. Systems capable of launching from air, surface, and subsurface platforms at safe distances and then reposition as needed receive higher marks than close-range distributed network systems that have no organic propulsion capability.

Structure: This criterion is included as part of the eight defining top level functions of AUWS, and is representative of the reliability, survivability, susceptibility, maintainability, availability, etc. of the individual system. As the concepts are academic constructs of the system, and all unfeasible architectures are removed from contention, this criterion results in no discernible variation among the proposed systems.

Cost-Effectiveness: This criterion is included due to the inherent need for any new system to be affordable and cost-effective. Prior to a thorough cost analysis and without existing systems to consider, the task of estimating costs is extremely challenging. Rough differences in order of magnitude are considered (e.g. cost of a heavyweight torpedo vs. cost of a series of nodes similar to those in development today) based on the team’s existing knowledge and experience. However, no fine differentiations are made outside of system size and complexity. This process serves as the foundation for an in depth cost analysis for the selected concepts.

Table 3.3 shows the matrix that is utilized to compare, contrast, and select viable and desirable alternatives. Alternative 1 is chosen as a reference arbitrarily. It receives all “0”s to show that it is the baseline for analysis. For other alternatives, a “+” means that, for a given category, that alternative has more desirable traits than Alternative 1. A “0” means that no real differentiation between the capability of the alternative and Alternative 1 exists. A “-” means that one or more traits of the alternative in question are noticeably less desirable than Alternative 1 in that category. Summing the scores such that a “+” rewards one point, a “-“ deducts one point, and a “0” results in no points rewarded or deducted, a cumulative score is determined.

Table 3.3: Scoring Matrix

Function	Alt. 1	Alt. 2	Alt. 3	Alt. 4	Alt. 5	Alt. 6	Alt. 7
Power	0	-	+	-	+	-	+
C3	0	-	-	-	0	0	-
ISR	0	0	-	0	0	+	0
Prosecute	0	-	+	0	0	0	-
OPSEC	0	-	-	-	0	0	-
Maneuver	0	-	-	-	+	-	0
Structure	0	0	0	0	0	0	0
Cost-Effectiveness	0	0	+	-	0	0	+
Score	0	-5	-1	-5	+2	-1	-1

3.2.3.2 Results

From Table 3.3, it is shown that Alternatives 1 and 5 receive the highest marks, while Alternatives 3, 6, and 7 tie for third place. Alternatives 2 and 4 are discarded due to low scores.

Upon further analysis, Alternatives 1 and 5 are combined into the single Alternative 5, since physical size is the only significant difference between the two alternatives, and a lightweight torpedo is utilized by other concepts. For ease of reference, the selected alternatives (3, 5, 6, and 7) are given the following designators:

- **Alternative 3. SQUID:** named for its prosecution method, which was inspired by the way a squid attacks its prey.
- **Alternative 5. V-CAP (Variable CAPability):** named for its ability to be configured for sensing/communication or prosecution capabilities within the same form factor.
- **Alternative 6. LD-UUV:** named for the large diameter UUV that comprises the main body of the system.
- **Alternative 7. GLIDER:** named for the gliding UUVs that comprise the network.

3.2.4 Design of Experiments

Even within a single combination of physical element types, there exist many possible system architectures. For example, the physical elements could be mobile or fixed, large or small, centralized or distributed, etc. Each of the selected alternatives has its own associated system architecture and it is important to determine if the four concepts represent a good sample of possible architectures. Using a Design of Experiments (DOE) approach enables a panoramic view of all possible architectures. The goal is to see if the selected alternatives fall within the same region of the design space, indicating redundancy, or if a large portion of the design space is not represented.

The design space is composed of three factors, weapons, sensors, and communicators, each set at various levels. The characteristics for which levels are varied are shown in Table 3.4. From the first four characteristics alone, there are 16 possible levels for each factor. The last characteristic, configuration, is unique because the level of one factor affects another factor. For example, a sensor combined with a communicator limits the configuration possibilities of the communicator. Elements can be separate, combined with each of the other two, or all three can be combined, resulting in four possible configuration levels. The first 16 levels for each element are assumed to be separate, so 3 levels are added for a total of 19. Figure 3.20 graphically illustrates the overall design space for AUWS.

Table 3.4: Various Levels Considered for AUWS Factors

Characteristic	High (+)	Low (-)
Size	Large	Small
Location	Centralized	Distributed
Intelligence	Smart	Dumb
Mobility	Mobile	Stationary
Configuration	Combined	Separate

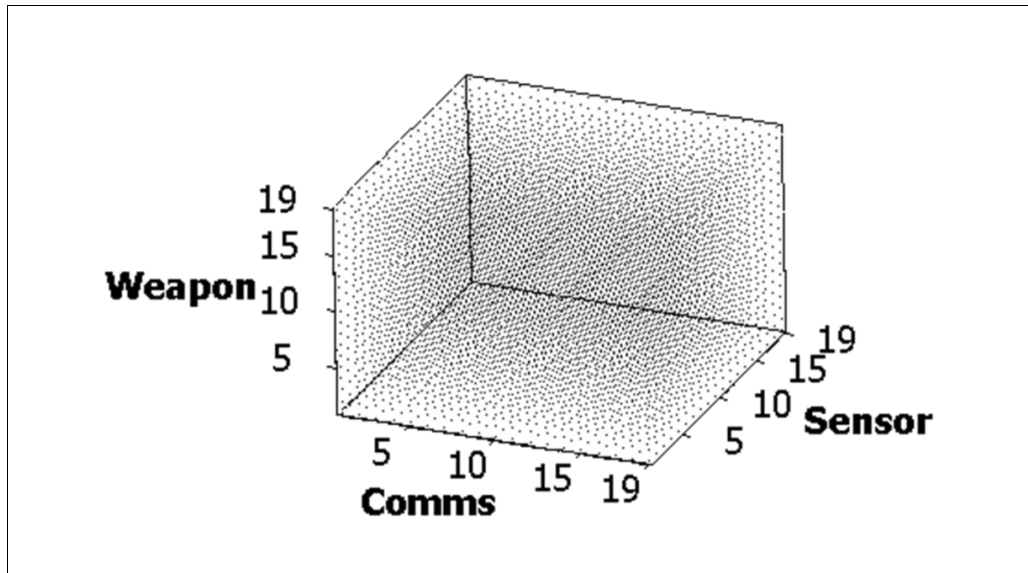

Figure 3.20: AUWS Design Space

From this design space, there are slightly less than 6,859 possible system architectures since some factor-level combinations are infeasible (e.g. a fixed sensor cannot be combined with a mobile communicator). Figure 3.21 shows a random sample of possible system architectures (S: Sensor; C: Comms; W: Weapon).

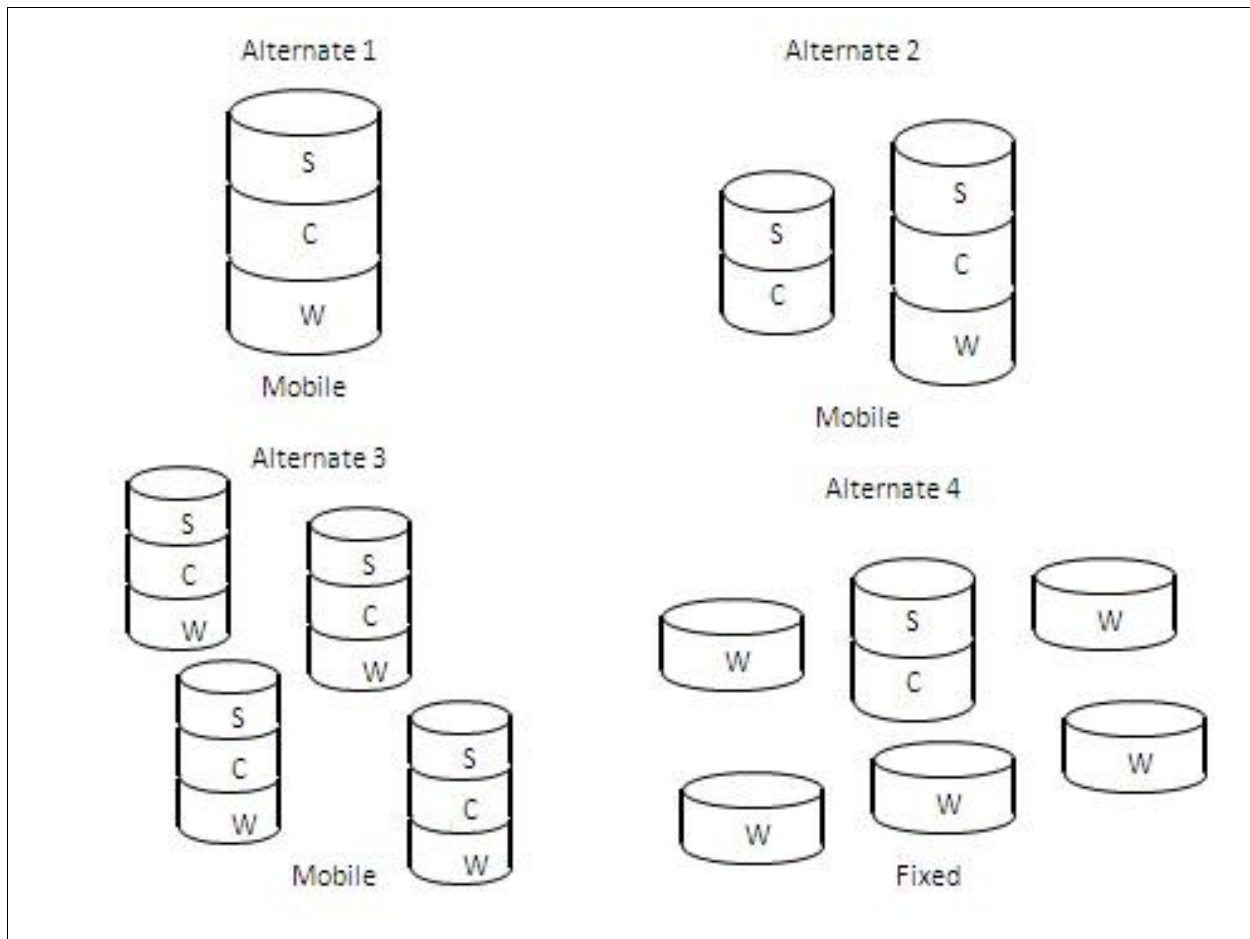

Figure 3.21: Sampling of Possible AUWS System Architectures⁴⁷

As modeled, the four selected alternatives effectively cover the design space; however, changes were made to the LD-UUV system based on the DOE process. Initial concepts for this alternative involved a swarm of smaller UUVs working in concert with a seabed sensor network. A quantitative look at the four selected system architectures revealed that the “swarm” concept was covered in many aspects by both Glider and Squid. Furthermore, mini-torpedoes were already used by V-CAP, while none of the alternatives used a weapon even as large as a lightweight torpedo. Consequently, the UUV and the weapon for this alternative were both enlarged in order to examine a previously neglected system architecture.

DOE is used here as a validation tool and not in the traditional way as a means of identifying the ideal system architecture. It is shown, however, that the concepts are modular

⁴⁷ Osmundson, John. Combination Diagrams. Monterey: Naval Postgraduate School.

enough that the most beneficial aspects of each can be effectively integrated into a hybrid concept. Employing the best levels for each factor increases confidence that an ideal system architecture is achieved; however, a full factorial or fractional factorial experiment is recommended to verify these results.

4. Overview of Selected Concepts

A detailed description of the four AUWS concepts, **Squid**, **V-CAP**, **LD-UUV**, and **Glider**, selected from the Alternative Generation process is given here to clarify not only the physical design of the concepts, but also how they accomplish the AUWS mission. Specific technologies for subsystems are mentioned to illustrate what is currently possible; however, a detailed design of system and subsystem components is reserved for further analysis. All performance parameters are based on unclassified and non-proprietary estimates from currently viable technologies.

The concepts are defined in detail for the purpose of supporting an Analysis of Alternatives, therefore all four concepts are assumed to have equal access to the most promising technologies as they emerge. In this way, the concepts are evaluated based on their critical elements, system architectures, and operational concepts.

4.1 Squid

The Squid system, as shown in Figure 4.1, consists of a network of individual nodes with deployable directed energy (DE) munitions acting as a limpet explosive via electro-magnetization (EM). The main objectives of the system are to establish a meshed network of interconnecting nodes for ISR purposes as well as the formation of a prosecution field to engage identified hostile targets.

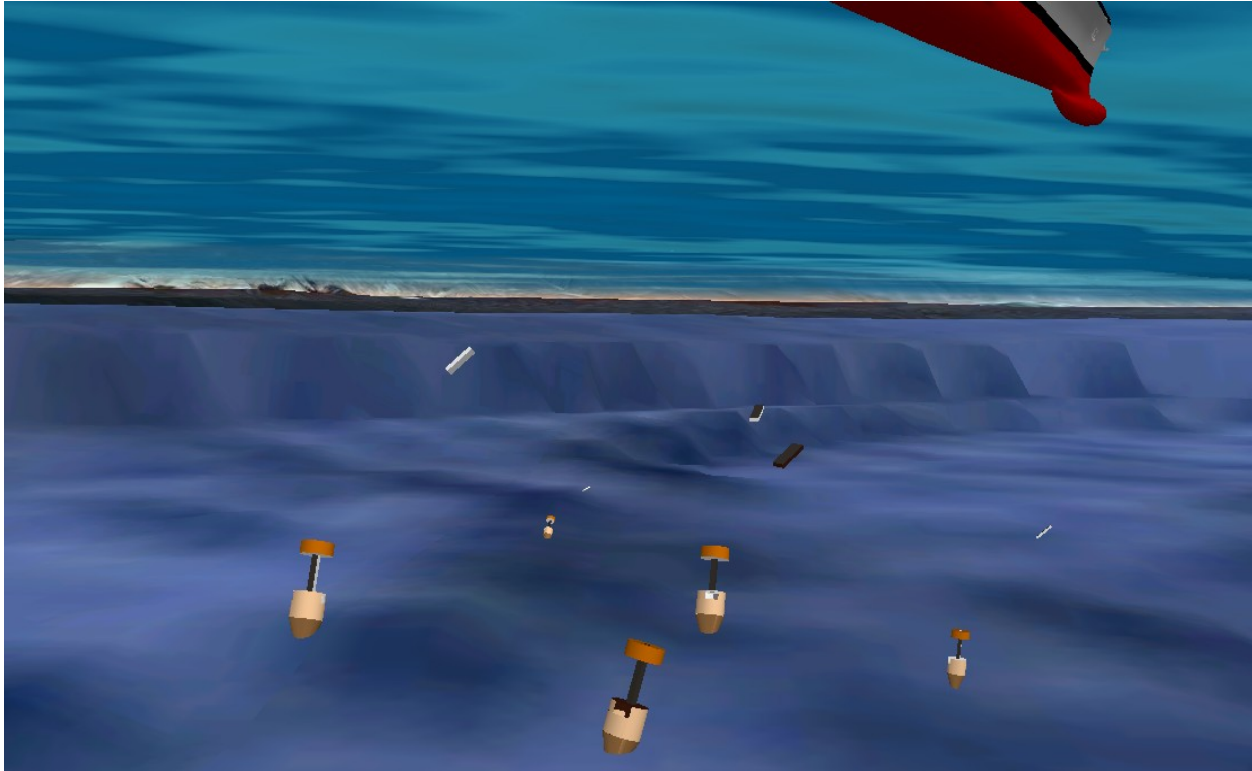

Figure 4.1: Notional Squid Field

4.1.1 Physical Description

The SQUID system consists of two types of nodes to be deployed: Weapons Nodes and Comms Nodes. The purpose of the Weapon Nodes is to deter, overwhelm, and engage identified hostile targets by deploying their DE munitions while the purpose of the Comms Nodes is to relay and transmit information collected back to the command center. Thus, the design for the two nodes differs due to their intended purposes as shown in Figure 4.2 (not drawn to scale).

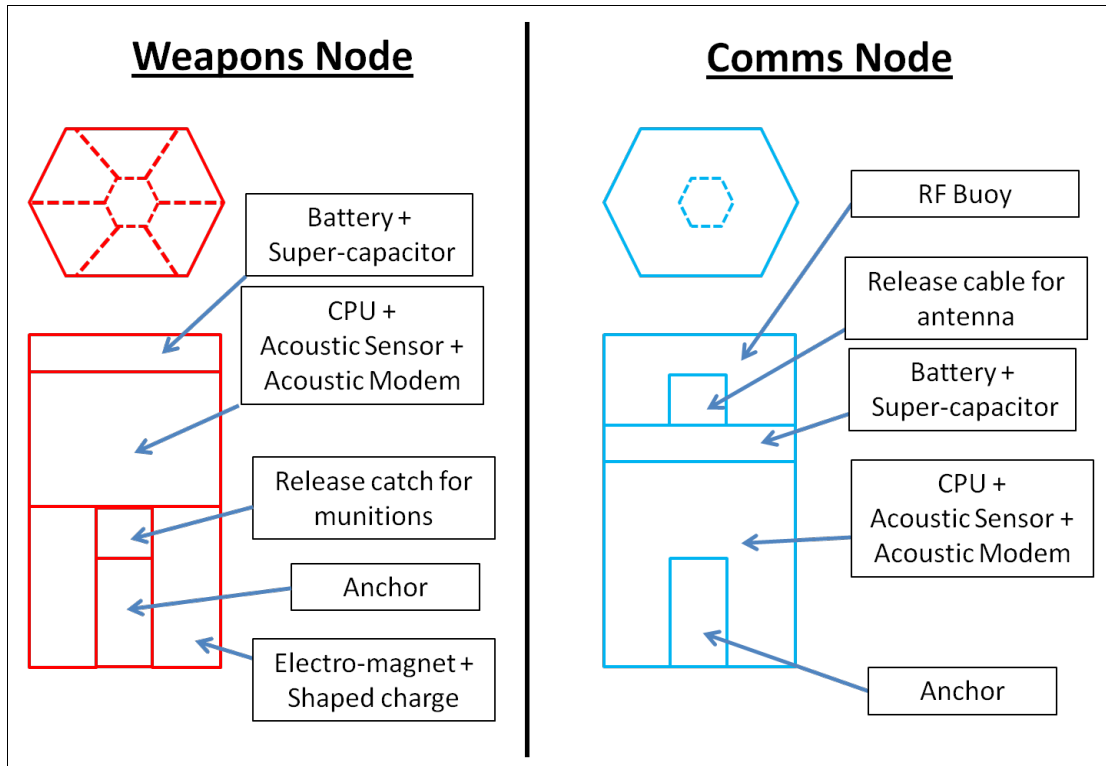

Figure 4.2: Squid Nodes

The Squid Nodes consist of a power unit, central processing unit (CPU), sensor and communication unit and an anchorage unit. The major difference between the two nodes is the addition of six 1kg shaped charges for engagement purposes on the Weapons Nodes and an additional RF buoy for external communications on the Comms Nodes.

As a reference, an artillery shell, such as the Long Range Land Attack Projectile (LRLAP) shown in Figure 4.3, would notionally be able to contain three Weapons Nodes. The 88 inch projectile provides sufficient space and can be launched up to 74 NM from the Zumwalt Class Advanced Gun System, providing a viable means of deployment.⁴⁸ The RF buoy and tethering cable for the Comms Node necessitate a larger size and therefore a separate means of deployment, such as air drop.

⁴⁸ Lockheed Martin Corporation. "Long Range Land Attack Projectile (LRLAP)." 2009. *LockheedMartin.com*. 4 May 2011.

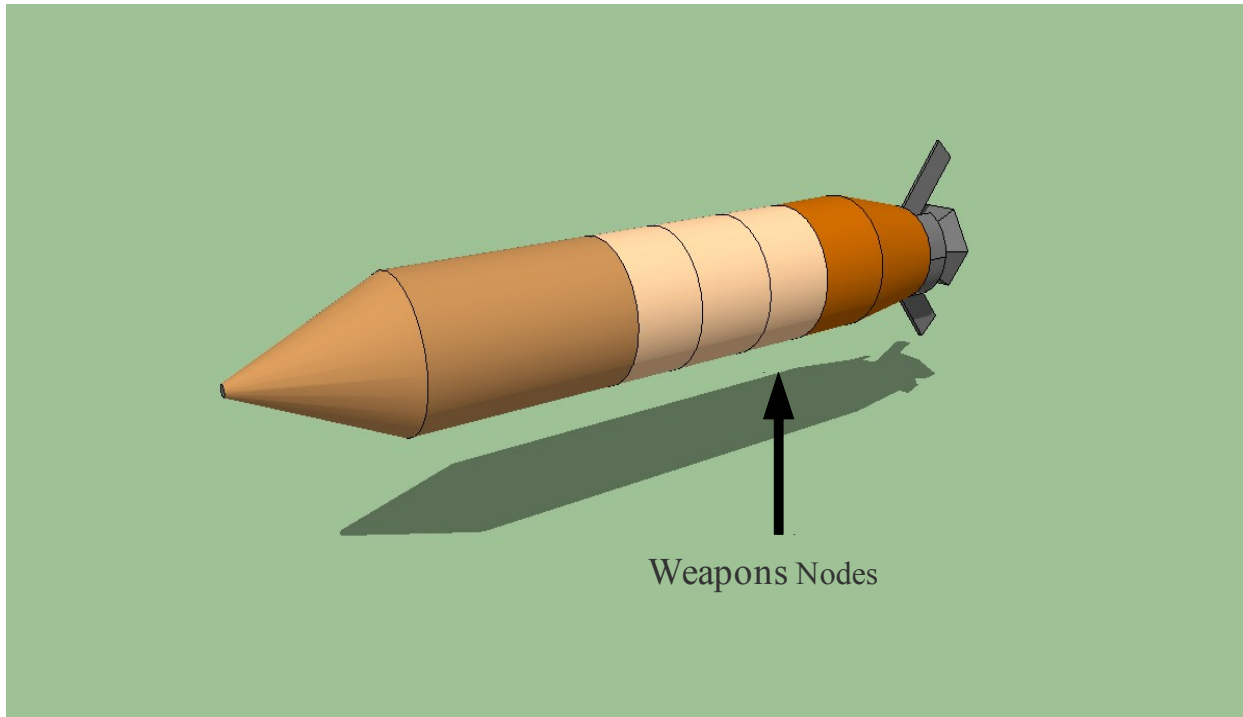

Figure 4.3: 155mm Long Range Land Attack Projectile⁴⁹

4.1.2 Functional Description

- **Power:** Power consuming entities in the Squid Nodes include the on-board CPU, acoustic sensor, acoustic modem, RF communications, mini-servo motors for cable releasing and retrieving, electro-magnets and the electric detonators for the shaped charge. Power for each node is provided via two sources: lithium ion battery for C3 and ISR requirements and ultra-capacitors for additional power required during engagement. Figure 4.4 illustrates the tradeoff between power and energy density for batteries and ultra-capacitors. Batteries store large amounts of energy but offer low power output compared to ultra-capacitors, which can provide higher power output for short periods of time.

⁴⁹ Pike, John. "Long Range Land Attack Projectile." 30 May 2007. *GlobalSecurity.org*. 4 May 2011. <<http://www.globalsecurity.org/military/systems/munitions/lrlap.htm>>.

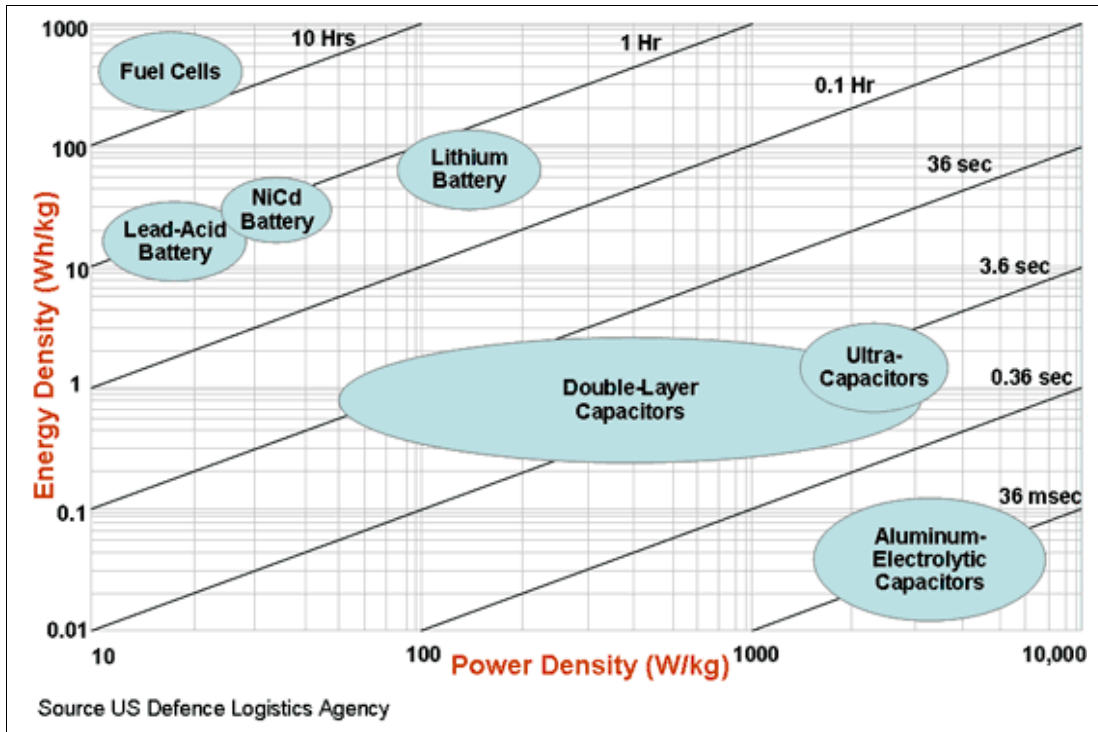

Figure 4.4: Ragone Plot of Electrochemical Devices⁵⁰

- **Propulsion:** Not applicable.
- **Weapons:** During engagement, the activated attack nodes release their magnetized DE munitions to float toward the surface in order to adhere to the metal hulls of the passing targets. Since magnetic force rapidly decreases in strength as distance increases, the effective range of the weapon is essentially limited by the trajectory of the explosive as it floats upward.
 - **Max Effective Range:** 50 yards
 - **Explosive Size:** 1 kg (shaped charge)
- **C3:** Internal communication between nodes within the system is accomplished via acoustic modem. The various nodes deployed to form the network act as relay nodes to transmit and transfer information collected to the Comms Node, usually one or a few, for further transmission to the Command Center to contribute to the common operational picture (COP). The system CPU is contained in the Comms Node for Command and

⁵⁰ Woodbank Communications Ltd. "Battery Performance Characteristics - How to specify and test a battery." 2005. [mpoweruk.com](http://www.mpoweruk.com/performance.htm). 3 May 2011. <<http://www.mpoweruk.com/performance.htm>>.

Control when operating autonomously. Each node determines the shortest path to the Comms Node(s). The data rate limitations on acoustic communication dictate that all nodes possess some signal processing capabilities to avoid sending raw acoustic data.⁵¹ Performance parameters are referenced to the baseline performance of the AquaComm® Underwater Wireless Modem, an analogous system developed by DSPComm. External communication is accomplished via surface RF antenna tethered to the Comms Node(s).

- **Acoustic Comms Range:** 0.8 NM (50% baseline due to size constraints)⁵²
- **Acoustic Data Rate:** 1 KB/min⁵³
- **RF Comms Range:** Line of Sight (may require airborne relay)
- **ISR:** ISR is achieved through detection of acoustic signals, such as a ship's fuel systems or rotating machinery. Squid Nodes utilize hydrophones similar to those found in sonobuoys and other unattended acoustic sensors. A back-of-the-envelope (BOE) calculation, shown in Appendix F, leads to a conservative estimate of maximum detection range compared to current systems.
 - **Max Detection Range:** 1.35 NM (50% baseline due to size constraints)
 - **Max Track Load:** 5 per node
 - **Track Time Required for Contact Report:** 1 min
- **OPSEC:** Squid consists mainly of low technology components, therefore the impacts of losses to the enemy are mitigated in system design. Due to the relatively small size as well as the nature of the operation of the Squid system, exploitation of the Squid Nodes underwater would also be difficult. Comms Nodes are the only elements that contain valuable information for the enemy, and Weapons Nodes can defend them from approaching threats.

4.1.3 Deployment

Weapons Nodes are primarily deployed via aerial insertion. Naval artillery, as shown in Figure 4.5, cruise missiles, and aircraft are all viable means of delivery. Weapons Nodes are

⁵¹ This premise holds true for all four concepts.

⁵² DSPComm "AquaComm: Underwater Wireless Modem." 2009. *DSPComm.com*. 2 May 2011.

<http://www.dspcomm.com/products_aquacomm.html>.

⁵³ DSPComm 1.

distributed somewhat randomly throughout the AOR, depending on accuracy of deployment. For the purposes of this analysis, artillery launch is considered surface deployment. Over-the-side surface deployment, however, is considered risk prohibitive because it would create an overt naval presence in the AOR for an extended period of time. Capacity and covertness constraints result in very little added value for submarine deployment. Comms Nodes are deployed separately, surface, subsurface, or aircraft delivery, and placed strategically to optimize communication networks. For example, one Comms Node would be placed in the center of the AOR or two would be placed in the center of two halves of the AOR.

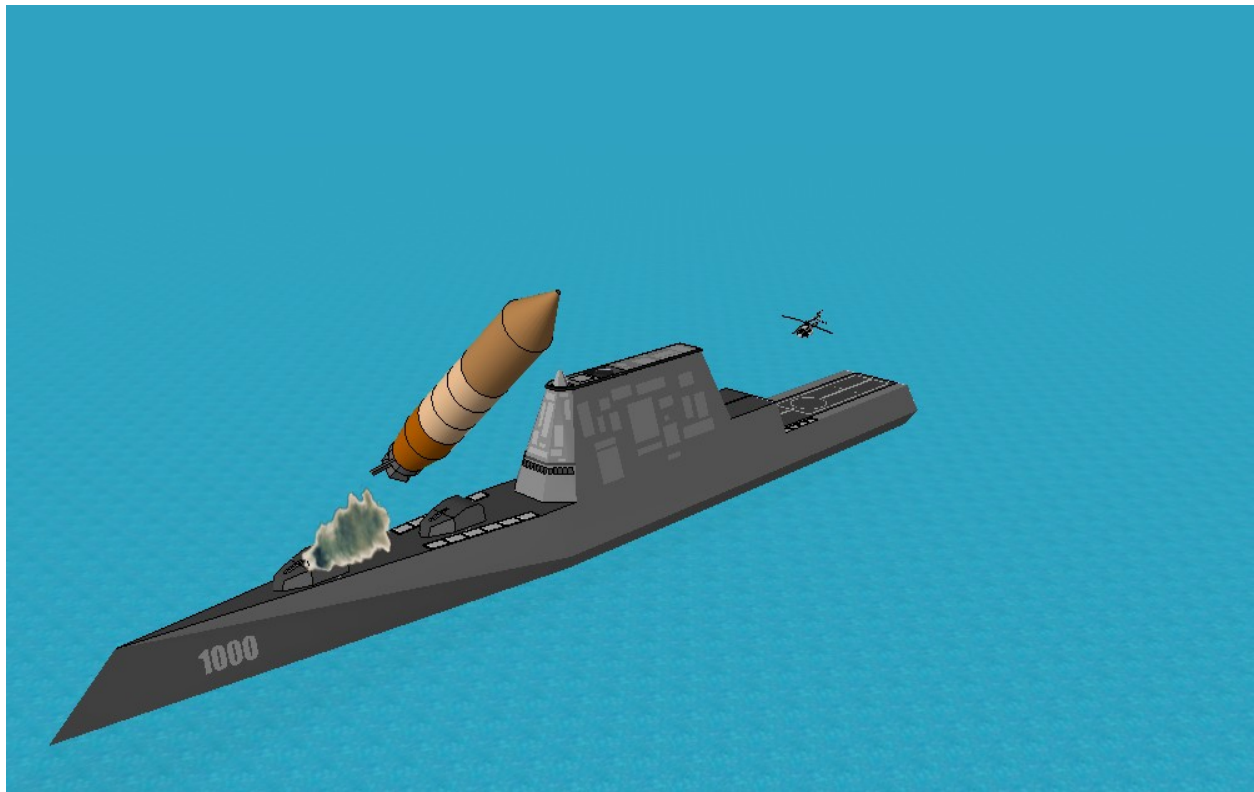

Figure 4.5: DDG-1000 Advanced Gun System⁵⁴

After settling to the seabed, both Weapons and Comms Nodes must anchor to prevent drifting and ensure the communications network and prosecution field remain robust. Their small size and deployment concept prohibit the use of heavy weights. Effective anchoring can be achieved by mimicking marine life. RoboClam® Anchoring Technology, developed by Bluefin Robotics, utilizes the kinematics of the Atlantic razor clam to provide 3000 lbs of holding force

⁵⁴ Bacon, Lance. "The Scoop Deck - Advanced Gun System hits milestone." 28 May 2010. *MilitaryTimes.com*. 2 May 2011. <<http://militarytimes.com/blogs/scoopdeck/2010/05/28/advanced-gun-system-hits-milestone/>>.

in an eight inch long anchor, expending roughly one third the energy in one AA battery.⁵⁵ RoboClam® burrows into the seabed with alternating vertical motion, which fluidizes the soil, as illustrated in Figure 4.6.

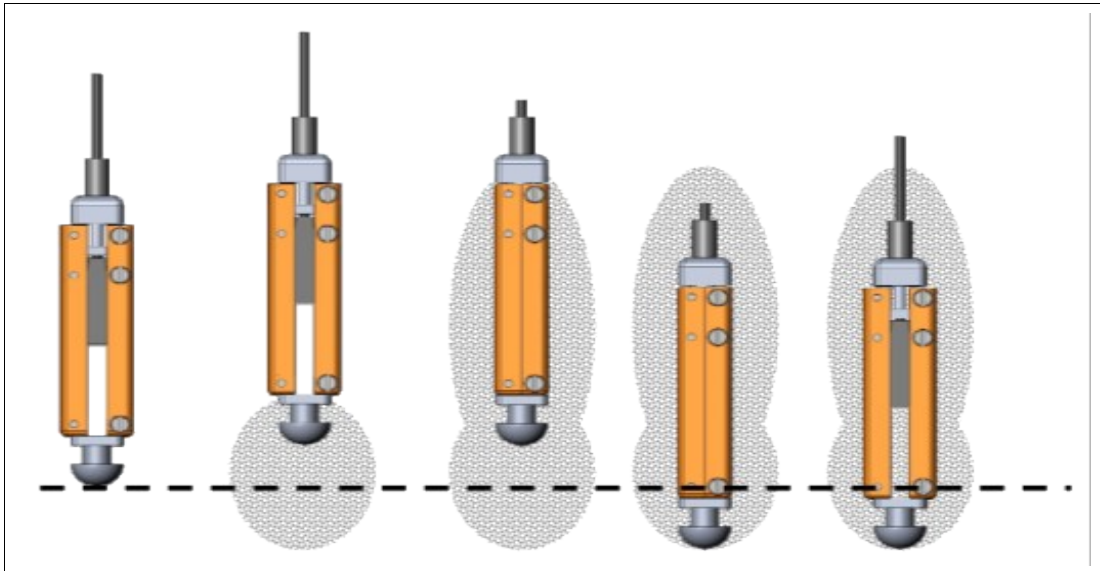

Figure 4.6: RoboClam® Digging Kinematics and Soil Fluidization⁵⁶

4.1.4 Operational Employment

Once on station, Weapons Nodes establish communications with their nearest neighbor nodes and determine the shortest path to the nearest Comms Node. If a Weapons Node lands too far from any nearest neighbor it is not able to communicate with a Comms Node and therefore it is not considered part of the overall system. Weapons Nodes transmit and relay all contact reports to the nearest Comms Node, which either communicates externally or decides system response, depending on the level of autonomy. If an engagement is ordered, Weapons Nodes in the path of the threat release their limpet explosives, which float upward and attach magnetically to the ship's hull. The explosives can be detonated based on contact, timer, or pre-programmed acoustic signal to give more flexibility to the operational commander.

4.1.5 Recovery

Squid is not intended to be recovered. The large number of nodes required for effective employment and lack of mobility of the system make recovery impractical. Squid is intended

⁵⁵ Bluefin Robotics. RoboClam Anchoring Technology. Boston: Bluefin Robotics, 2011.

⁵⁶ Bluefin Robotics 1.

instead to be expendable and cost-effective by maintaining a low unit cost. Weapons and Comms Nodes scuttle themselves based on a predetermined timer or acoustic signal.

4.2 V-CAP (Variable CAPability)

The V-CAP system consists of twin UUVs, Hunter and Killer, modeled as a hybrid of heavyweight and lightweight torpedoes. The units are designed to be deployed from multiple platforms such as submarines, surface ships, aircraft and unmanned systems. Upon launch, the units transit on a pre-programmed route and speed to the AOR, providing a safe standoff range for the deploying platform. V-CAP conducts ISR via a self deployed distributed network and conducts prosecution via encapsulated torpedoes, similar to the concept of a CAPTOR Mine.

4.2.1 Physical Description

V-CAP Hunter and Killer Units are 21 inches in diameter, based roughly on the shape of a Mk-48 torpedo.⁵⁷ The units are modular, allowing for lengths between 12 and 19 feet depending on mission requirements. As shown in Figure 4.7, the units are designed to be externally identical for ease of deployment, recovery, maintenance, and storage. The Hunter Unit consists of energy storage, propulsion, CPU, sensor payload, and a tethered communication buoy. When anchored vertically, the modules are laid out in the water column along a central tether, with the communications buoy on the surface. The Killer Unit houses two miniature torpedoes, and power, propulsion, and navigation equipment.

⁵⁷ IHS Global Limited. "Mk 48 ADCAP." 27 July 2010. *Janes.com*. 3 May 2011.

http://search.janes.com.libproxy.nps.edu/Search/documentView.do?docId=/content1/janesdata/yb/juws/juws0501.htm@current&pageSelected=allJanes&keyword=Mk 48 torpedo&backPath=http://search.janes.com/Search&Prod_Name=JUWS&.

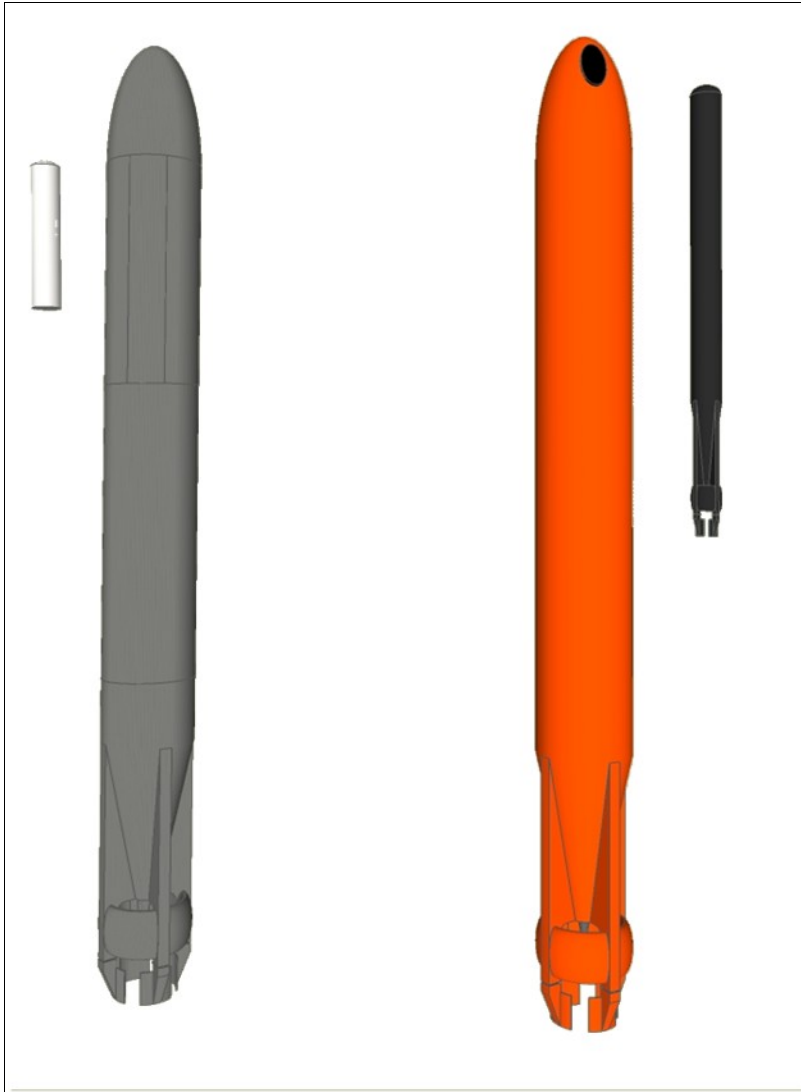

Figure 4.7: V-CAP Hunter (left) and Killer (right)

4.2.2 Functional Description

- **Power:** V-CAP adopts a hybrid system for power, utilizing chemical fuel for ingress and egress while utilizing batteries to power all other electronic devices. Solid state chemical fuels, such as OTTO Fuel II mono-propellant, offer high energy densities without the need for an oxidant and have proven reliable for underwater propulsion.⁵⁸ Batteries offer rapidly improving energy densities and enable a recharge capability. A potentially viable, albeit immature, technology is power generation through wave or current motion, which

⁵⁸ Copperhead Chemical Company. "OTTO Fuel II." January 2006. *CopperheadChemical.com*. 3 May 2011. <http://www.copperheadchemical.com/Defense/OTTOFuelII_0106.pdf>.

could be employed as a module in the Hunter Unit. This technology could prolong on-station time, but not indefinitely.

- **Propulsion:** The propulsion system of V-CAP is modeled after the Mk-46 torpedo. It similarly uses a two speed reciprocating external combustion engine using OTTO Fuel II to power its propeller and drive it through the water on ingress and egress. V-CAP transits at lower speeds than the Mk-46,⁵⁹ reducing drag and power required. The propulsion system and fuel storage, however, must occupy a much smaller portion of the overall vehicle. A detailed calculation of maximum range (assuming zero on-station time) based on these considerations can be found in Appendix F.
 - **Max Speed:** 20 kts
 - **Max Range:** 221 NM (@ 5 kts)
- **Weapons:** The V-CAP Killer Unit utilizes miniature, or very lightweight, torpedoes for prosecution of threats. Using the Compact Rapid Attack Weapon (CRAW) as a guide, the unit can easily hold two of the 6.75 inch diameter weapons.⁶⁰ Further miniaturization of the V-CAP weapon may be needed to accommodate other systems contained within the Killer Unit when it is configured for airborne deployment (shorter length). Therefore, range and warhead size are conservatively estimated. The miniature torpedoes are intended to conduct mission kills by homing on threat vessel propulsion systems.
 - **Max Range:** 3000 yds⁶¹
 - **Warhead Size:** 20 kg
- **C3:** Internal communications between sensor nodes, Hunter Units, and Killer Units are accomplished via acoustic modem. Sensor nodes transmit and relay all messages indiscriminately to the Hunter Unit. External communication is accomplished via tethered RF antenna that is deployed to the surface from the Hunter Unit nose cone. When operating autonomously, Command and Control is performed by the Hunter Unit CPU, which sends engagement orders to Killer Units.

59 IHS Global Limited. "Mk 46 Torpedo." 6 December 2010. *Janes.com*. 3 May 2011
<http://search.janes.com.libproxy.nps.edu/Search/documentView.do?docId=/content1/janesdata/yb/juws/juws0493.htm@current&pageSelected=allJanes&keyword=Mk 46 Torpedo&backPath=http://search.janes.com/Search&Prod_Name=JUWS&>.

60 McMullen, Teresa. *Compact Rapid Attack Weapon (CRAW)*. Arlington: 2009.

61 McMullen 12.

- **Acoustic Comms Range:** 1.6 NM (baseline)⁶²
- **Acoustic Data Rate:** 1 KB/min⁶³
- **RF Comms Range:** Line of Sight (may require airborne relay)
- **ISR:** ISR is achieved primarily through acoustic detection by deployed sensor nodes and the Hunter Unit. Sensor nodes each contain a hydrophone while the Hunter Unit utilizes a vertical hydrophone array. The Hunter Unit also uses an EO/IR sensor located with the communication buoy for visual detection and target confirmation.
 - **Max Detection Range:** 2.7 NM (baseline, refer to Appendix F)
 - **Max Track Load:** 5 per node
 - **Track Time Required for Contact Report:** 1 min
- **OPSEC:** For OPSEC concerns, all communications are encrypted and both Hunter and Killer Units are designed to be tamper-proof and contain self-destruct mechanisms that can destroy sensitive information stored within the units.

4.2.3 Deployment

V-CAP is designed to be deployed from multiple platforms, such as submarines via torpedo tubes as shown in Figure 4.8. Prior to deployment, the intended ingress and egress routes as well as the designated buoy release points and the unit anchor point must be preloaded within the units as they are not capable of communicating with the deploying unit during transit.

62 DSPComm "AquaComm: Underwater Wireless Modem." 2009. *DSPComm.com*. 2 May 2011
<http://www.dspcomm.com/products_aquacomm.html>.

63 DSPComm 1.

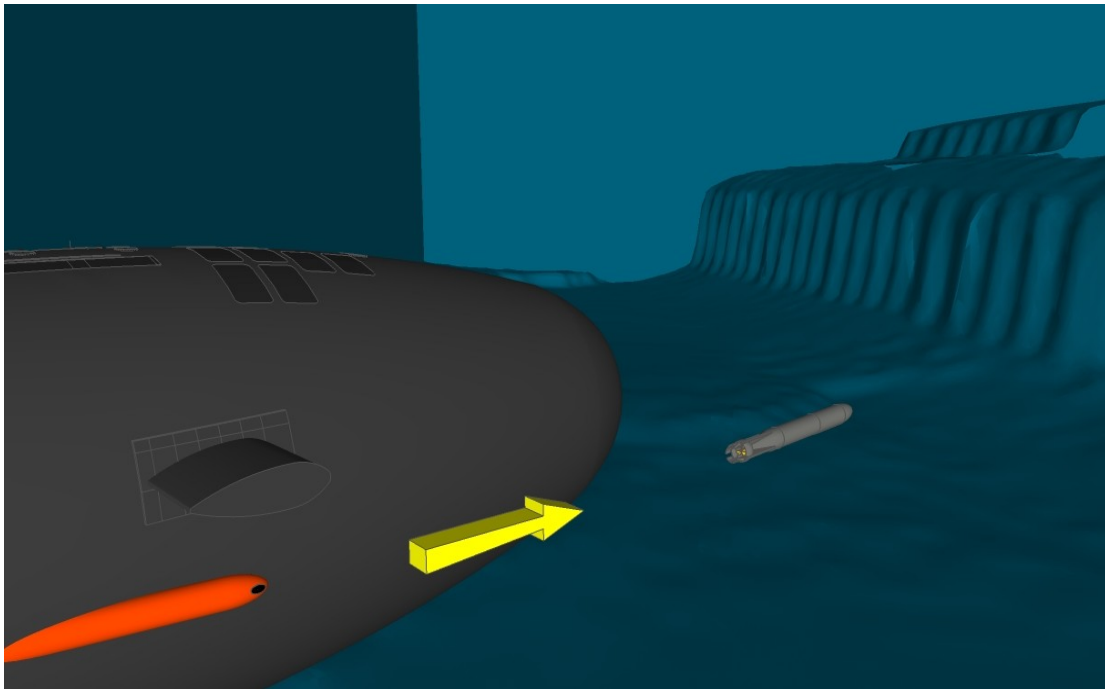

Figure 4.8: Submarine Launch of V-CAP

4.2.4 Operational Employment

Upon reaching its AOR, the Hunter Unit proceeds with dispensing a network of sensor nodes from an internal storage bay, as shown in Figure 4.9.

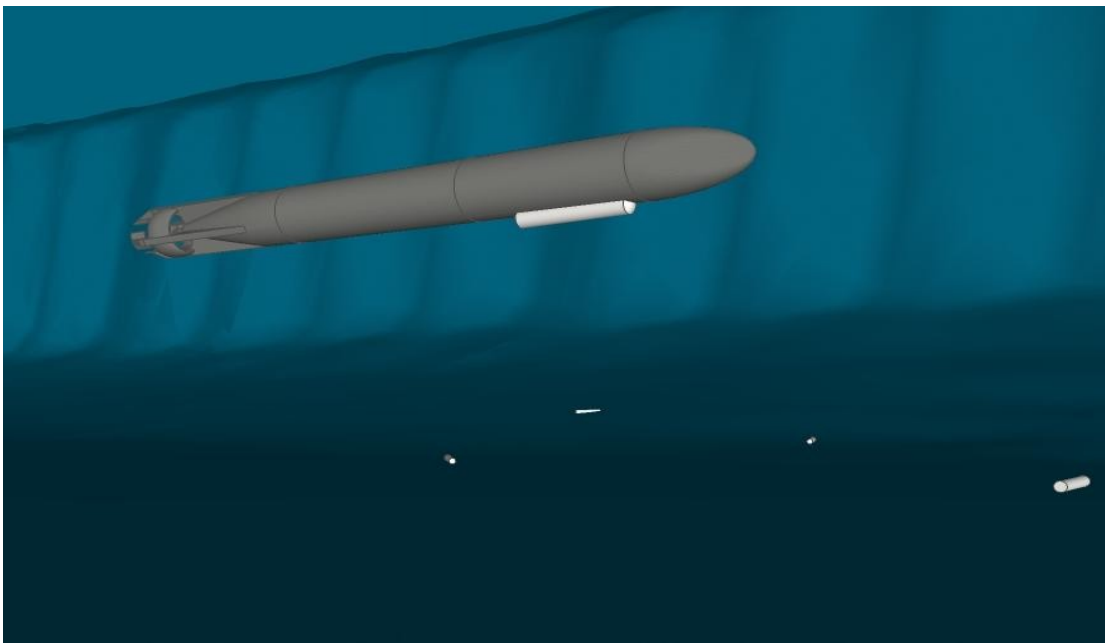

Figure 4.9: Deployment of V-CAP Sensor Nodes

Once the network has been laid, the Hunter Unit proceeds to its pre-determined anchor point where it anchors itself in a vertical configuration with its tail end on the seabed, the mid-section floating about 50 yards above the tail, and the nose section floating on the ocean surface. All sections are tethered together. The Hunter Unit acts as a central processing node and it receives sonar information from the sensor nodes and processes the information in tandem with the information its own sonar system collects. Unless operating autonomously, any potential target identified is relayed back to a command center where a human operator serves as a man-in-the-loop to verify and issue the engagement order.

The Killer Unit deploys simultaneously to the AOR and serves as a prosecution unit. The unit operates by swimming into the AOR, anchoring itself within communications range of the Hunter Unit and awaiting an engagement order and targeting information, as shown in Figure 4.10. V-CAP mini torpedoes are equipped with self guidance sonar seeker heads that guide the torpedoes to the target. Depending on the mission and AOR, multiple Hunter and/or Killer Units may be employed in coordination.

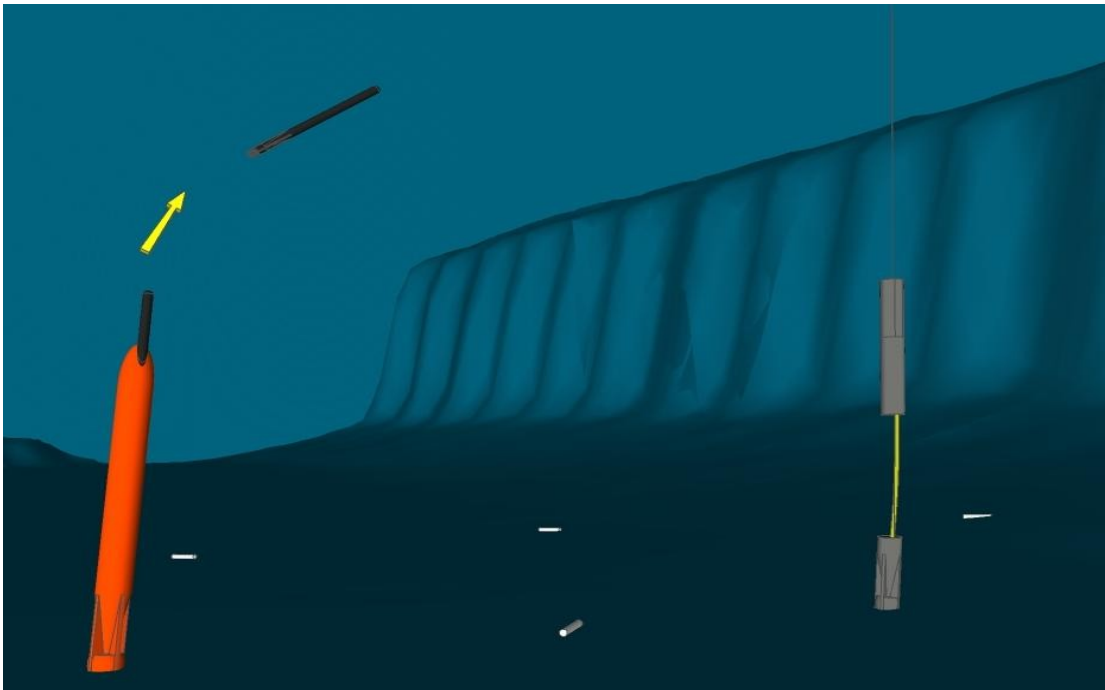

Figure 4.10: V-CAP Operation and Engagement

4.2.5 Recovery

Both Hunter and Killer Units are designed to be recoverable by surface and subsurface assets. Upon completion of its mission the Hunter Unit collapses via tethered line back into torpedo form, then each unit un-anchors from the seabed and proceeds on its planned egress route. Egress routes can be updated and transmitted to the UUV units while they are still deployed should the need for a new recovery point arise. Upon arrival at the designated recovery point, both units can float to the surface or navigate into open submarine torpedo tubes. All unexploded ordnance must be jettisoned before recovering the Killer Unit.

4.3 Large Diameter UUV (LD-UUV)

The AUWS LD-UUV concept is an extension of Navy and industry LD-UUV research and experimentation currently being conducted. This concept integrates the vehicle with an intelligent, distributed sensor network and lightweight torpedoes. Rather than focusing on a modular UUV capable of delivering a multitude of materiel (munitions, sensors, etc.), the AUWS LD-UUV concept focuses efforts on being an armed, networked ISR and prosecution asset.

4.3.1 Physical Description

The vehicle itself, as shown in Figure 4.11, is based loosely on the Large Diameter, Long Duration (L2D2) UUV currently being developed by Naval Surface Warfare Center, Panama City Division. L2D2 is 254 inches long and 59 inches in diameter.⁶⁴ The AUWS LD-UUV is larger to make use of the 87.5 inch diameter (and at least 18 feet long)⁶⁵ Multiple All-up-round Canisters (MAC) employed on SSGNs and Virginia Payload Tubes (VPT) on Virginia Class SSNs.⁶⁶ LD-UUV carries eight pairs of intelligent sensors nodes, connected by 1000 yards of fiber optic cable, to be delivered within the AOR. The LD-UUV can carry up to four lightweight torpedoes internally. In equipment bays not occupied by sensor nodes, removable battery extension packs can be installed to enhance the permanent onboard power supply.

64 Dudinsky, John. *L2D2: Large Diameter Long Duration UUV*. Panama City: 2011.

65 MACs are known to carry the Tomahawk missile, which is 18 feet long in its shortest variant.

66 Pike, John. "SSN-774 Virginia-class NSSN New Attack Submarine." 5 Sept. 2008. *GlobalSecurity.org*. 1 May 2011. <<http://www.globalsecurity.org/military/systems/ship/ssn-774-spiral-2.htm>>.



Figure 4.11: AUWS Large Diameter UUV

4.3.2 Functional Description

- **Power:** LD-UUV is powered by lithium ion, lithium polymer, or next generation batteries. The energy storage system is modular to allow for more batteries if the payload space is available. Power and energy requirements are recognized as a significant technical challenge for UUVs; however, the large size of LD-UUV should allow for sufficient energy storage space to provide necessary power.
- **Propulsion:** For propulsion, the LD-UUV makes use of an electric motor to turn an external propeller. Variable control surfaces provide maneuverability.
 - **Max Speed:** 6 kts⁶⁷
 - **Max Range:** 290 NM @ 2 kts⁶⁸

⁶⁷ Dudinsky 12.

⁶⁸ Dudinsky 12.

- **Weapons:** LD-UUV utilizes Mk-50, Mk-54, or next generation lightweight torpedoes for threat prosecution. The use of lightweight torpedoes balances firepower with size and weight requirements, allowing mission and/or asset kills while not sacrificing endurance, maneuverability, etc. Torpedoes are canted upward, outward, and forward in the vehicle body to maximize space for other equipment. Since Mk-50 and Mk-54 torpedoes only operate in circular search mode, software modifications may be needed to give the LD-UUV weapon a line-of-bearing search capability.
 - **Max Range:** 8 NM⁶⁹
 - **Warhead Size:** 45 kg (shaped charge)⁷⁰
- **C3:** The LD-UUV serves as the gateway for communications between the sensor network and external command centers. A retractable RF antenna buoy is surfaced during normal operation for external communications (as a backup, the vehicle itself can physically carry messages to a command platform). Sensors communicate with each other via a combination of acoustic modems and fiber optic cables. Sensors that are physically connected to each other can communicate at high data rates with minimal power draw. Command and Control is distributed among the sensors and the LD-UUV. The network utilizes parallel processing techniques to make decisions as a group rather than relying on a central command node. Sensor node capabilities are referenced to 75% baseline due to the space and power requirements for higher processing capabilities.
 - **Acoustic Comms Range:** 1.2 NM (75% baseline)⁷¹
 - **Acoustic Data Rate:** 1 KB/min⁷²
 - **RF Comms Range:** Line of Sight (may require airborne relay)
- **ISR:** Passive acoustic sensors are employed at each sensor node. Current hydrophone technology is used as an analogy to estimate performance specifications.

69 IHS Global Limited. "Mk 50 (Barracuda) Lightweight Torpedo." 6 May 2010. *Janes.com*. 1 May 2011 <http://search.janes.com.libproxy.nps.edu/Search/documentView.do?docId=/content1/janesdata/binder/jalw/jalw3119.htm@current&pageSelected=allJanes&keyword=Mk 50 torpedo&backPath=http://search.janes.com/Search&Prod_Name=JALW&>.

70 IHS Global Limited 1.

71 DSPComm "AquaComm: Underwater Wireless Modem." 2009. *DSPComm.com*. 2 May 2011 <http://www.dspcomm.com/products_aquacomm.html>.

72 DSPComm 1.

- **Max Detection Range:** 2.0 NM (75% baseline, refer to Appendix F)
- **Max Track Load:** 5 per node
- **Track Time Required for Contact Report:** 1 min
- **OPSEC:** The use of fiber optic cables reduces risk of counter detection by eliminating approximately half of the acoustic signals in the network. All data and data processing is encrypted due to sensitive contact classification algorithms and contact data libraries present on each sensor node. Scuttle charges are also employed to destroy sensitive hardware.

4.3.3 Deployment

LD-UUV can be deployed by a surface vessel, via davit or crane, or by a submarine, as shown in Figure 4.12. For submarine deployment, payloads should be configured prior to the mission so LD-UUV can deploy without the need for diver assistance. Airborne deployment is considered infeasible due to the large size of the vehicle. Even if an air drop did not damage the vehicle, few naval aircraft could support delivery.

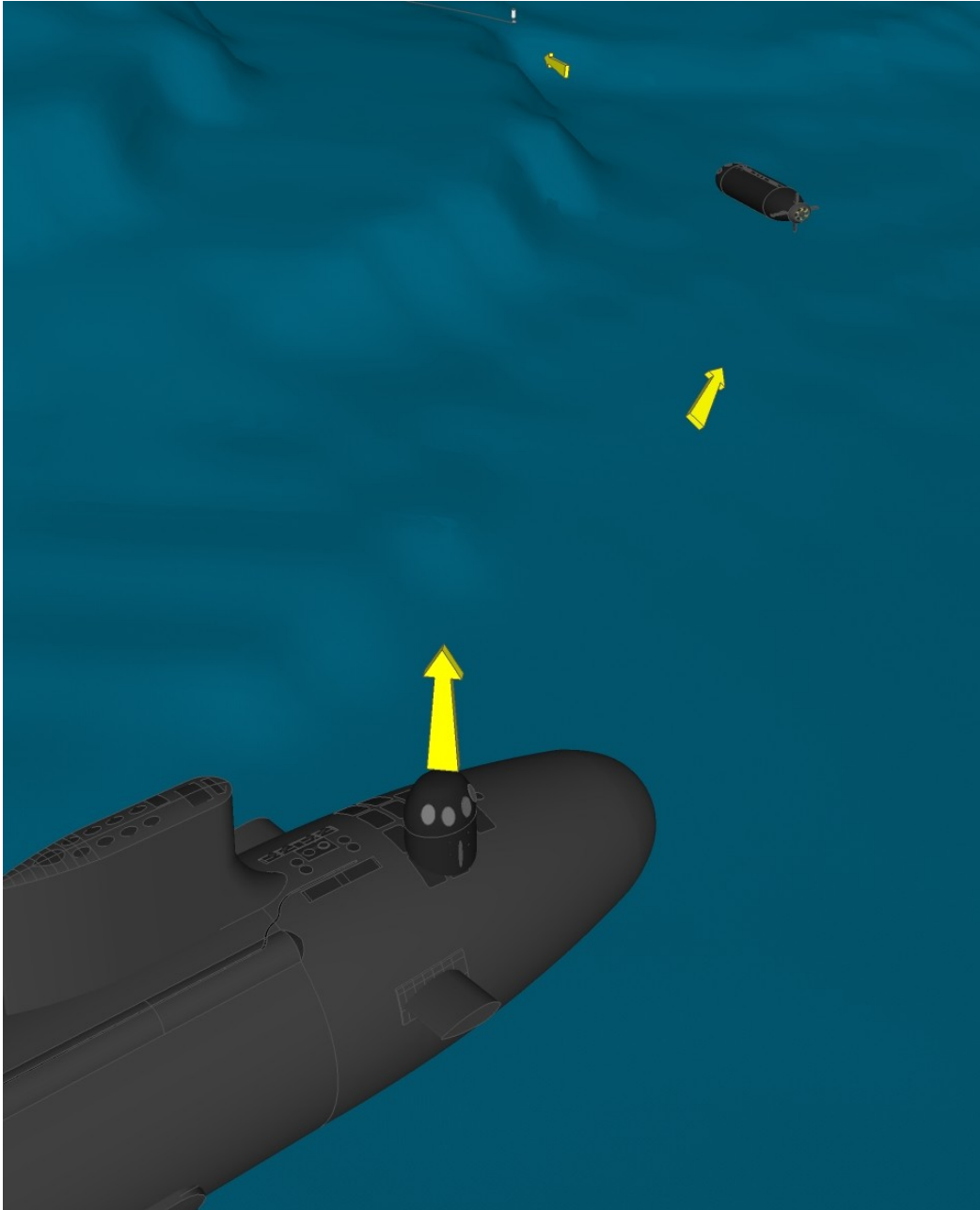

Figure 4.12: Submarine Deployment of LD-UUV

4.3.4 Operational Employment

LD-UUV transits to the AOR under its own navigation. Once it reaches the preprogrammed point in the AOR, it surfaces to confirm its position via GPS and establishes communications with the command center to transmit status and receive direction. After confirming its position and communicating, it returns to depth via a vertical dive.

A vertical dive maneuver is performed to generate the sound speed profile (SSP). The SSP is used to calculate the maximum distance between node pairs and the maximum length of cable permissible between connected sensor nodes. Should the cable be severed, the nodes would be required to communicate via acoustic backup. If a cable is too long it would place the nodes out of acoustic range of one another. At operational depth, the LD-UUV deploys sensor nodes as necessary for the mission.

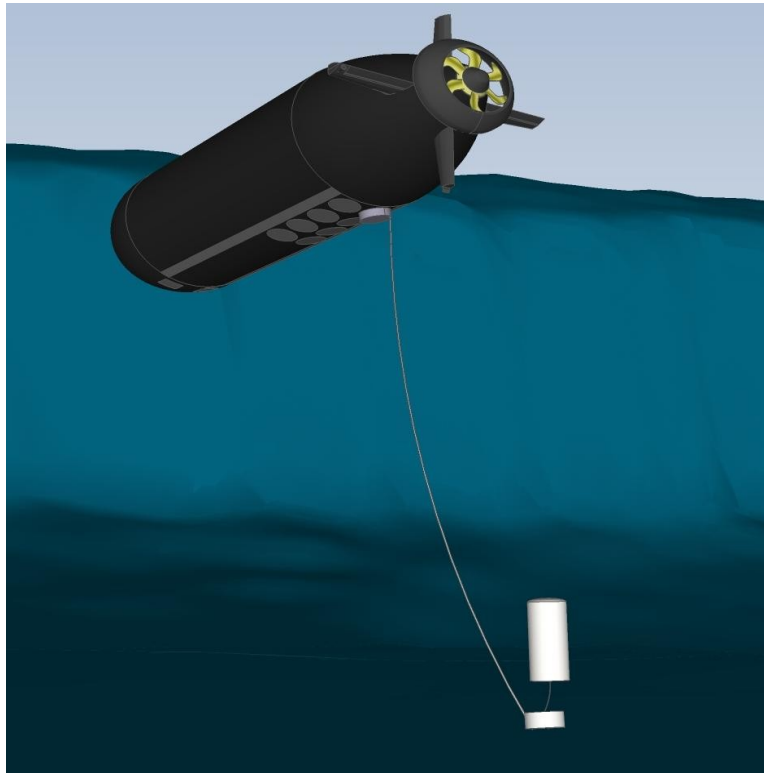

Figure 4.13: LD-UUV Deploying Paired Sensor Nodes

As shown in Figure 4.13, LD-UUV releases one sensor node as it traverses over the seabed paying out the appropriate amount of cable before releasing the second connected node. The nodes are delivered diagonal to the intended flow of traffic to balance benefits of simultaneous tracking from multiple sensors with improved communication time to the gateway. Once the paired nodes have been delivered, LD-UUV comes to rest on the seabed at the center of the AOR within communication range of the nearest nodes.

ISR operations commence once the sensor field is in place and the ad hoc network is created. Each node senses acoustic signatures from passing vessels. Paired nodes work together

to identify contacts based on the sensed characteristics. A contact report is generated and transmitted to the next nearest node pair in the path to the LD-UUV, or to the node pair that is in the expected path of the contact if more confidence is required. The report is compared and added to the decision algorithm of the new node pair to increase the confidence in the identification of potential targets.

If acting autonomously, the LD-UUV engages threats immediately upon receipt of a confirmed threat contact report, and sends external COI reports when it deems appropriate. Otherwise, the LD-UUV sends kill recommendations or COI reports to a command center based on mission parameters. Routine contact reports are held at the detecting sensor node until a period of low activity permits communication to the LD-UUV. System operation is shown in Figure 4.14.

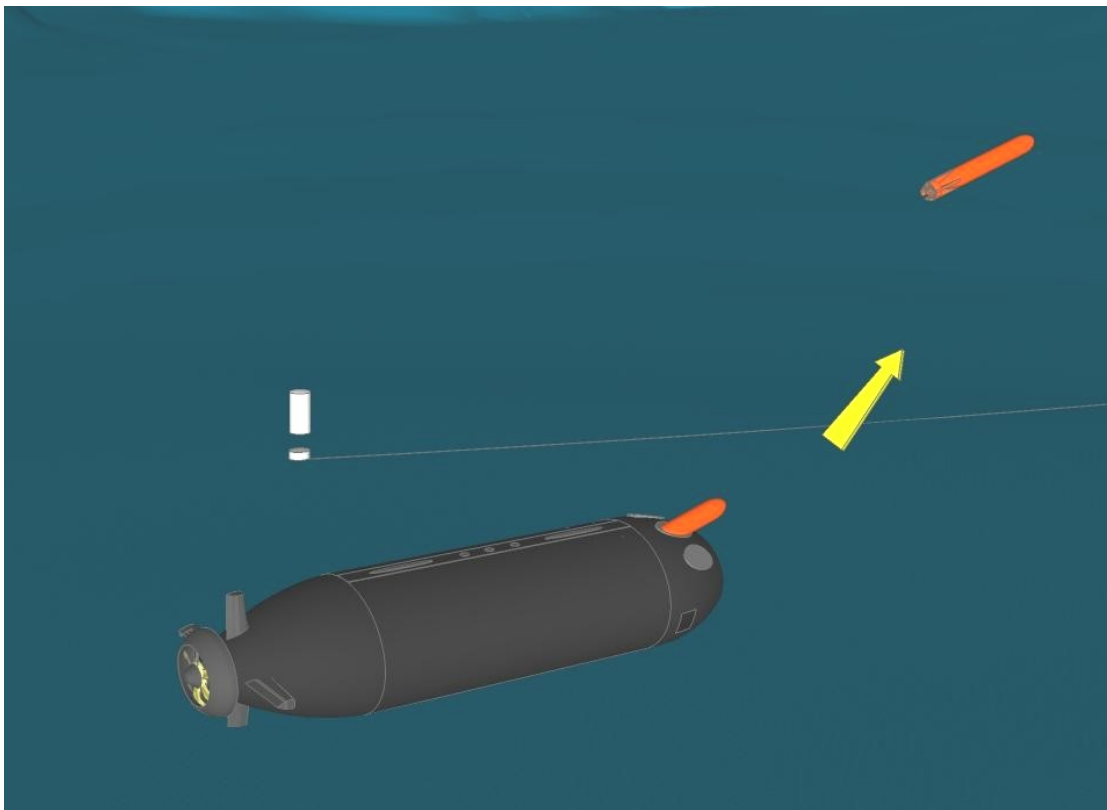

Figure 4.14: LD-UUV Operation and Engagement

4.3.5 Recovery

The LD-UUV returns to a designated point as the mission dictates. It may be after a certain period of time, at a particular battery state, or upon receipt of command. One more option is for the LD-UUV to remain on station until complete battery discharge. This option requires manned retrieval in a potentially hostile environment. Once it has arrived at the rendezvous point, divers are required to re-seat the LD-UUV into an empty MAC, as shown in Figure 4.15. A retrieving surface vessel requires divers to attach a hoisting harness.

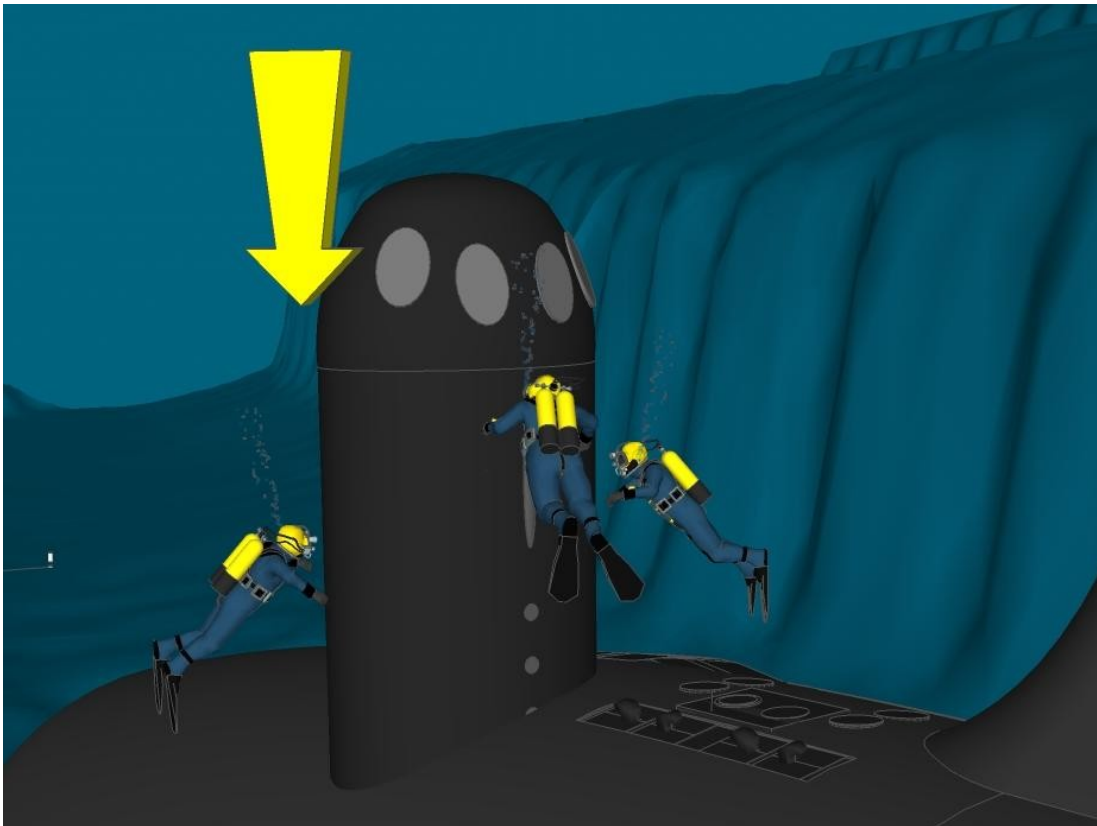

Figure 4.15: Submarine Recovery of LD-UUV

4.4 Glider

The AUWS Glider concept utilizes small, lightweight UUVs that convert vertical motion into forward motion through variable buoyancy. This technique drastically reduces power requirements for propulsion, extending range and on-station time. Several Gliders compose a homogeneous ISR network that coordinates to cover an AOR. In order to communicate with an external network Gliders proceed to the surface. Each Glider is a self contained weapon used for

threat prosecution equipped an internal warhead in the nose that detonates upon intercept with a threat vessel.

4.4.1 Physical Description

The Glider, as shown in Figure 4.16, is approximately 6 feet in length and 10 inches in diameter, weighing about 100 kg. Two controllable sets of wings maximize its hydrodynamic propulsion. The tail has a vertical stabilizer for steering control.

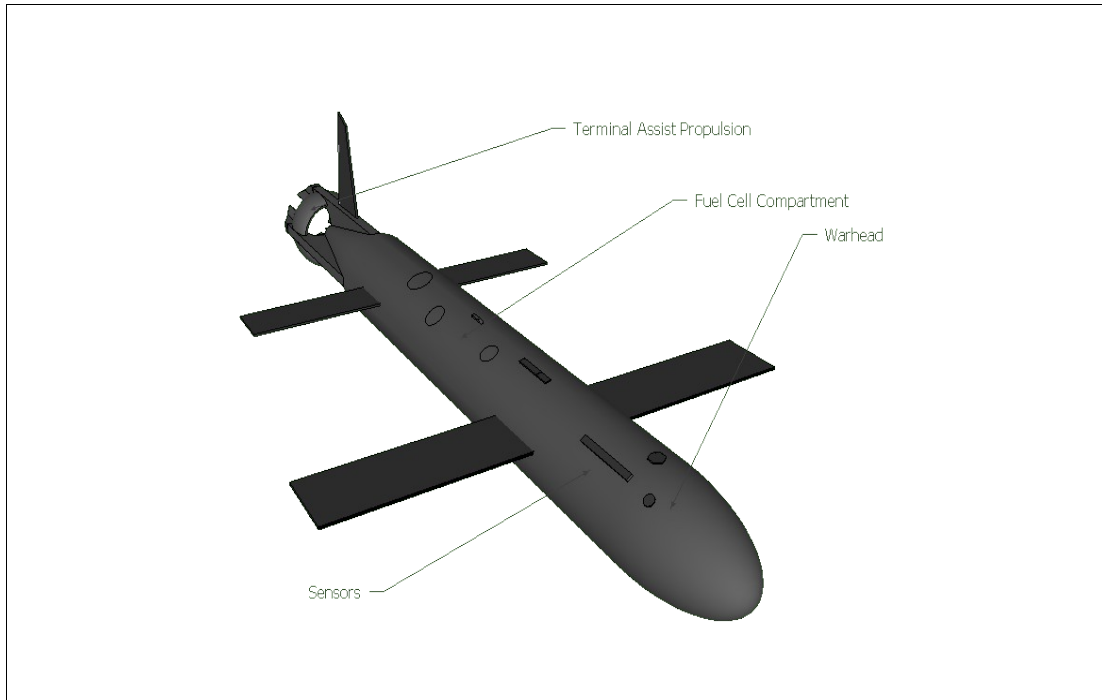

Figure 4.16: Glider UUV

4.4.2 Functional Description

- **Power:** The Glider's primary source of power is a fuel cell system designed to support the onboard sensor and navigation suite. A potentially viable candidate is a Magnesium-Air Fuel Cell (MAFC) which uses a magnesium anode, oxygen as a cathode and salt water as the electrolyte.⁷³ Fuel cell selection is dictated by size restrictions within the Glider UUV. As a possible supplemental source of power to support surface

⁷³ Messina, John. "Magnesium: Alternative Power Source." 23 Apr. 2010. *Physorg.com*. 3 May 2011 <<http://www.physorg.com/news191259549.html>>.

communication, solar cells located on the topside of the glider, could be used to enhance the operational duration of the communication sub-system.

- **Propulsion:** Glider uses buoyancy dynamics along with its wings to convert vertical motion force to horizontal propulsion force which requires very low power consumption. An internal ballast provides adjustable pitch and its steering is attained via a rudder/stabilizer system located in the rear of the craft. Buoyancy is adjusted through an internal compartment by varying volumes of seawater. While gliding motion greatly increases endurance and range, average horizontal speeds of only about 0.5 kts are attainable with existing technology. It is a critical assumption that by 2030 average horizontal speeds of two knots, which is evaluated as the minimum useful speed for tactical operations, will be sustainable. Glider also features a terminal speed boost by way of a propulsor tail cone assembly that is powered by OTTO Fuel II mono-propellant similar to fuel systems currently utilized in torpedoes.
 - **Max Speed:** 2 kts
 - **Max Range:** 810 NM (@ 2 kts)⁷⁴
- **Weapons:** Glider carries a 10 kg high explosive charge located at the top part of the nose of the craft. A shaped charge design ensures a high probability of success when prosecuting a threat. Glider utilizes the screw or other critical system of a ship or submarine target as the desired point of impact to maximize efficiency.
 - **Max Range:** 810 NM
 - **Warhead Size:** 10 kg (shaped charge)
- **C3:** Glider uses an RF antenna for surface communication with other networks in support of Command and Control requirements. The system also uses an Iridium® satellite based modem for navigation updates and an acoustic modem for internal communications between Gliders. The Glider navigation information and mission data is relayed between Gliders as well as provided to command centers via satellite and airborne relays. Onboard processing is used by Glider to determine potential threats from an internal database downloaded prior to mission initiation. Autonomous operation is formulated based on a

⁷⁴ Button, Robert W, et al. A Survey of Missions for Unmanned Undersea Vehicles. Santa Monica: RAND Corporation, 2009. 156.

typical mission profile involving ingress to the operational area, execution of mission waypoints/loitering in the mission area, and egress to a waypoint if the Glider has not been expended.

- **Acoustic Comms Range:** 1.6 NM (baseline)⁷⁵
- **Acoustic Data Rate:** 1 KB/min⁷⁶
- **RF Comms Range:** Line of Sight (may require airborne relay)
- **ISR:** ISR is achieved through detection of acoustic signals. Each Glider contains a hydrophone array and processed acoustic signals are shared with other Gliders via the network.
 - **Max Detection Range:** 2.7 NM (baseline, refer to Appendix F)
 - **Max Track Load:** 5 per node
 - **Track Time Required for Contact Report:** 1 min
- **OPSEC:** Glider produces no noise from combustion engines or motors; however, the acoustic emissions from constantly shifting ballast equipment may offset that noise reduction. Acoustic transmissions are encrypted and scuttle mechanisms are employed to prevent compromise.

4.4.3 Deployment

Glider is deployed via maritime surface and rotary wing air assets. Since the Glider UUVs are small and lightweight, they do not require special launching equipment. They can be launched from nearly any ship, such as the FFG shown in Figure 4.17, or helicopter using small teams, not just from specially fitted ships. In order to compensate for very low intercept speeds Gliders must be deployed in large quantities.

⁷⁵ DSPComm "AquaComm: Underwater Wireless Modem." 2009. *DSPComm.com*. 2 May 2011
<http://www.dspcomm.com/products_aquacomm.html>.

⁷⁶ DSPComm 1.

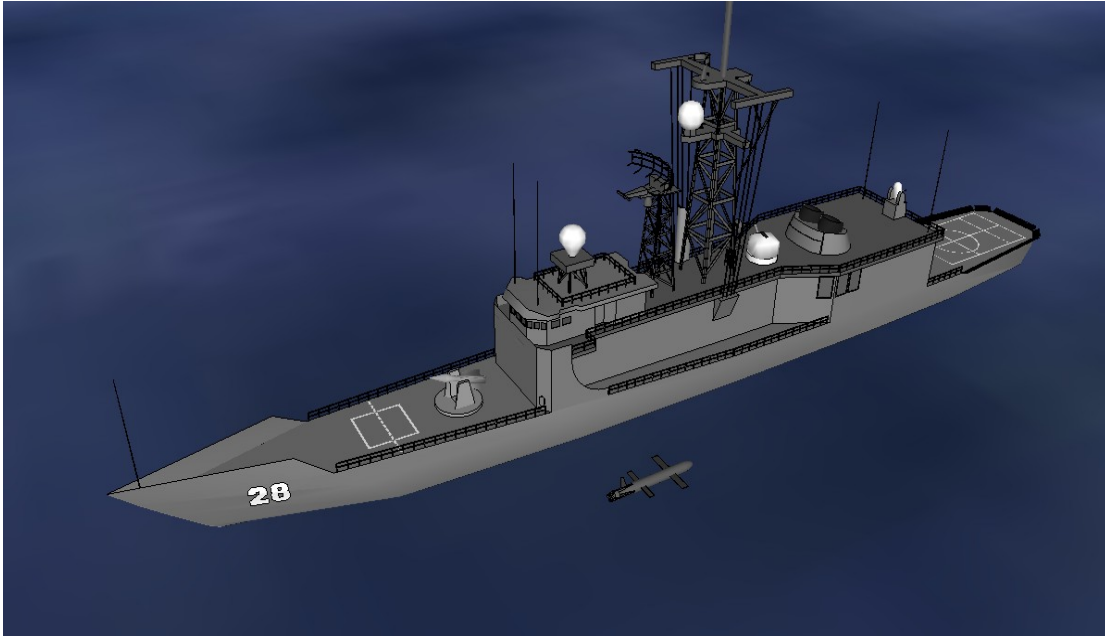

Figure 4.17: Surface Deployment of Glider⁷⁷

4.4.4 Operational Employment

During the execution of its mission, each Glider conducts a barrier search between waypoints programmed prior to mission start. Glider maintains communication with the nearest members of the network, as shown in Figure 4.18. Surfacing periodically, Glider communicates with the nearest airborne assets and satellites to support the ISR mission. Contacts are reported to a command center based on their perceived level of importance. When an engagement order is received (or generated by one of the Gliders), targeting information is sent to the Glider in best position to successfully conduct an intercept on the target vessel.

⁷⁷ All FFGs will be decommissioned by 2030. The purpose of this image is to show that any ship could deploy Gliders.



Figure 4.18: Glider Network Operation

4.4.5 Recovery

Upon completion of its mission, Glider transits out of the AOR and surfaces to await retrieval by surface asset. Embarked helicopters are a feasible option to assist in retrieval, as shown in Figure 4.19. If need be the Glider can self-destruct or enter a hibernation state to be retrieved at a future time.



Figure 4.19: Glider Recovery Assisted by Helicopter Retrieval

5. Analysis of Alternatives

The Analysis of Alternatives process, which deselects down to a single system architecture from the four selected concepts, is achieved via concurrent performance (effectiveness), cost, and risk analyses. Recommendations are made based on the results of these analyses, considering scenarios in which different factors have more value than others to stakeholders.

5.1 Performance Analysis

To accomplish a comprehensive comparative performance analysis of different architectures for the same conceptual system, a combination of stochastic modeling and simulation, analogous comparison using empirical evidence, and qualitative methods is employed. The results of those methodologies are then folded together with proper emphasis on individual factors to ensure appropriate analysis. It is imperative that results not just be averaged together to determine the most “effective system.”

Specific variables to be considered are identified and selected prior to analysis. The system MOEs and associated MOPs are a good place to start, but the amount of data required (some of which is not collectible outside of a Testing and Evaluation scenario) makes for a cumbersome and perhaps ineffectual analysis. To adequately assess the primary functions and identified need areas of AUWS, a set of seven MOEs (or representative MOPs) is selected to scope the analysis. These measures, with their associated units, are listed below:

1. **Probability of Detection (%)**: probability of AUWS successfully detecting a real contact. P_d is modeled as the percentage of total contacts encountered by AUWS that are detected.
2. **Probability of Kill (%)**: probability of AUWS successfully prosecuting valid threat, resulting in at least a mission kill. P_k is modeled as the percentage of total threats encountered by AUWS that are killed.
3. **Average Data Message Completion Time (minutes)**: the time it takes for AUWS to send a message to an external network, from message generation (e.g. ship detection, in the case of a contact report) to the message being transmitted externally.

4. **Capability to Operate for a Minimum of 30 Days (days):** the capability for AUWS to conduct operations in an AOR for 30 days, independent of external C2 or logistical support.
5. **Capability for Deployment by both Contemporary and Future Platforms (number of platforms):** capability for AUWS to be deployable from air, surface, and subsurface assets in the current or projected Navy inventory.⁷⁸
6. **Capability for Recovery by both Contemporary and Future Platforms (number of platforms):** capability for AUWS to be recoverable by air, surface, and subsurface assets in the current or projected Navy inventory.
7. **Capability to provide OPSEC (rating):** capability for AUWS to avoid detection by enemy or neutral entities and, if detected, avoid compromise of sensitive information and equipment. This metric is used as a proxy for the Probability of Detection Avoidance MOE.

5.1.1 Modeling and Simulation

The ability for AUWS to detect contacts, communicate to external networks, and prosecute threats is analyzed using modeling and simulation. These functions are selected for modeling because they relate directly to initial tasking and the critical physical elements of AUWS (weapons, sensors, and communicators). The system concepts are modeled using various simulation programs and analytical models are used as inputs to realistically simulate system operation. The system models are evaluated in a generic scenario representing an international waterway. Their resulting performance is used to gain operational insights and contribute to overall Analysis of Alternatives.

5.1.1.1 Methodology

The primary program used for modeling system concepts is ExtendSim 7.0, a discrete event simulator (DES) developed by Imagine That! Inc. ExtendSim is an ideal platform for analyzing end to end models of system concepts because it can produce emergent behavior when the various system, target, and environmental parameters are incorporated into the simulation. A sample screen shot of the V-CAP model in ExtendSim is shown in Figure 5.1.

⁷⁸ Shore deployment capability primarily supports experimentation and testing and is therefore not considered in the operational performance analysis.

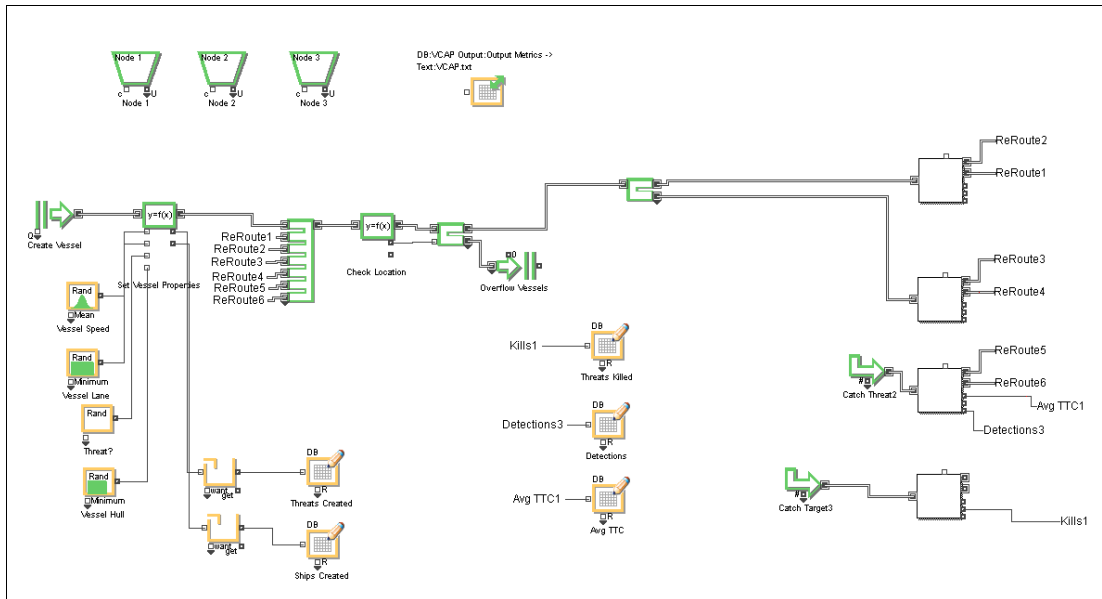

Figure 5.1: Screen shot of ExtendSim model (V-CAP)

Three of the four selected concepts are modeled in ExtendSim, with the exception of Squid, which is instead modeled in MATLAB 2010, a numerical computing environment and programming language developed by The MathWorks, Inc. MATLAB is ideally suited to model the random nature of Squid’s deployment methodology. Graphical output of a developing Squid field is shown in Figure 5.2. Green areas represent communication ranges and the red area represents an overlap where two nodes can communicate with each other.

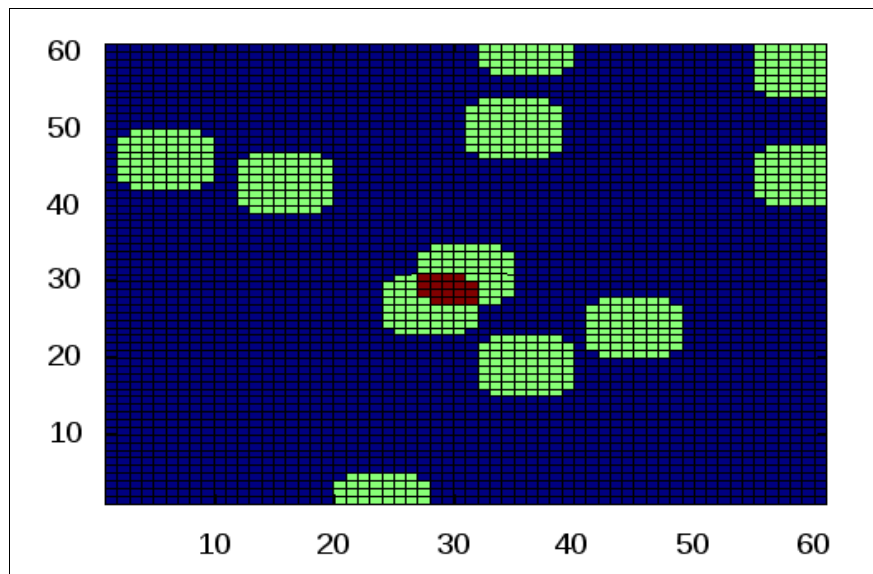

Figure 5.2: Sample graphical output of MATLAB model (Squid)

In order to provide realism for threat engagement, a physics-based model for weapon effectiveness is used as an input to the system models. The weapon model, which can be found in Appendix F, calculates a peak overpressure based on detonation distance from the target and compares it to a randomly generated value (within typical limits) for hull strength. Sensor performance, on the other hand, is simulated with a notional exponential curve for Pd as a function of range to contact at closest point of approach (CPA). Pd is 90% for contacts that pass directly over a sensor, and reduces down to zero as CPA approaches maximum detection range. This approach represents an improvement over “cookie cutter” sensor models; however, further analysis using a physics based sensor model is recommended.⁷⁹

Finally, Simkit, an open source Java based program DES maintained by Professor Arnold Buss of the MOVES Institute at NPS,⁸⁰ is utilized to help visualize system behavior and operational concepts. While performance is not analyzed using this program, a visual representation is generated that provides insight into the way systems should be operationally employed. For example, optimal unit positioning and search patterns can be determined through the observation of a Glider field, shown in Figure 5.3.

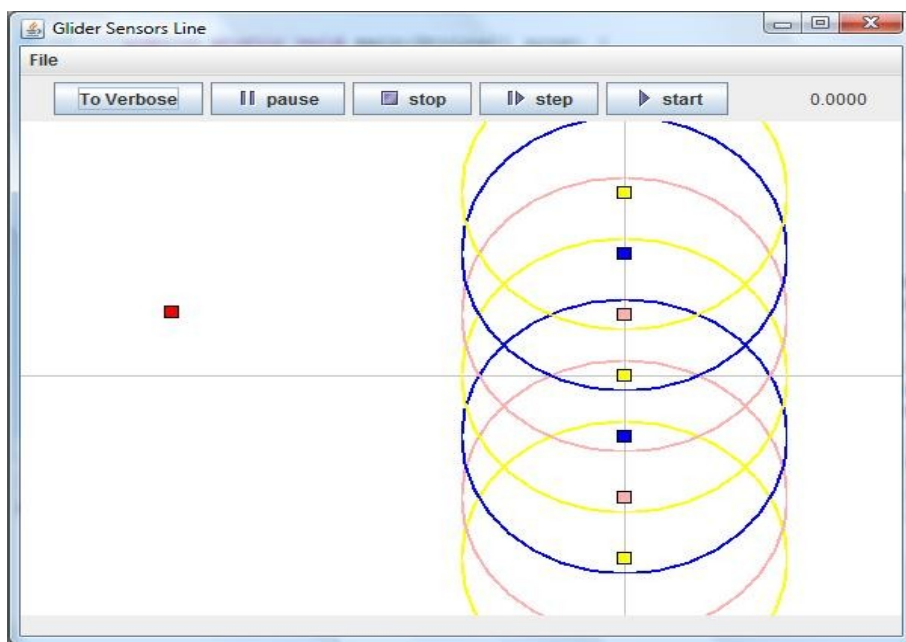

Figure 5.3: Sample screen shot of Simkit (Glider)

⁷⁹ An attempt was made at developing a physics based sensor model, but the model produced unreliable results. The attempted model can be found in Appendix F.

⁸⁰ Buss, Arnold. "Simkit Home Page." 24 Mar. 2010. *Diana.nps.edu*. 12 May 2011 <<http://diana.nps.edu/Simkit/>>.

5.1.1.2 Model Scenario and Setup

The baseline scenario used to evaluate and compare the four system concepts is shown in Figure 5.4. The scenario simulates a single day in a busy international waterway in which traffic generally moves along a single axis, such as a channel or traffic separation scheme. AUWS is tasked to develop an operational picture of a 10 NM by 3 NM AOR within the waterway and contribute to a COP. Specifically, the mission is to detect and track all contacts, report all contacts of interest, and prosecute all threats attempting to transit the AOR.⁸¹

In this particular scenario, AUWS is operating fully autonomously, so no permission or engagement order from higher authority is required for kinetic action. For modeling purposes, AUWS sends a concurrent message when engaging a threat. For all models, it is assumed that weapons function properly and that all threats are correctly identified. Aspects of threat discrimination, such as false negatives and false positives, are discussed separately, in Appendix G, by analyzing the performance of an analogous system. Also, Pd is assumed to be independent for each sensor, since targets are not taking evasive or counter-detection actions and factors affecting detection are mostly inherent to each individual sensor.

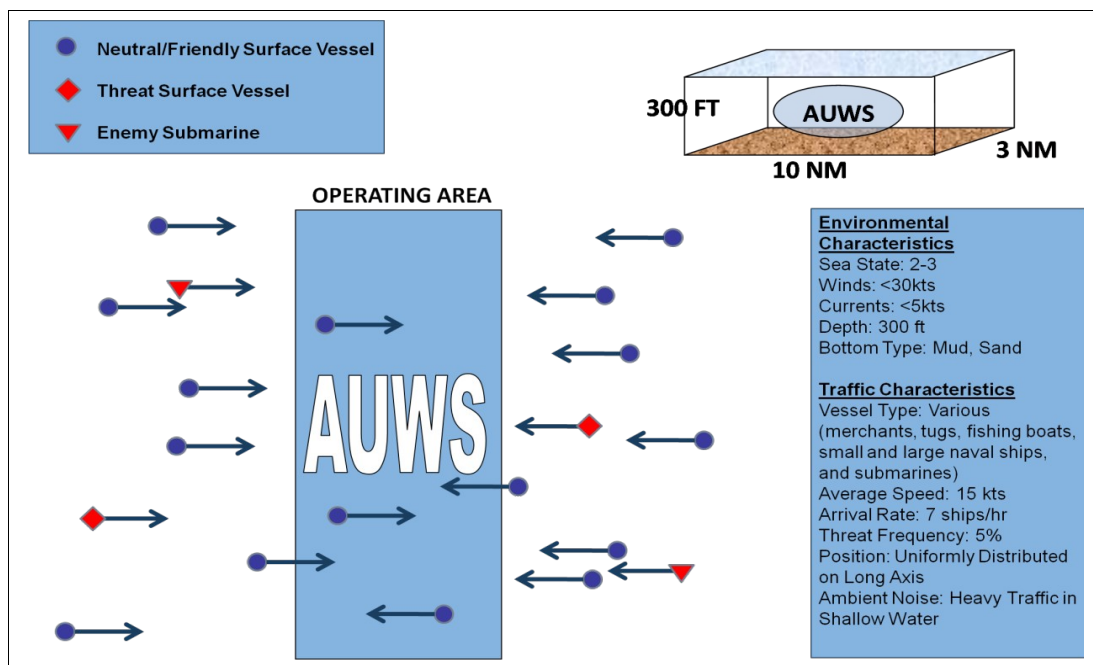

Figure 5.4: Baseline Model Scenario

81 Due to the mission parameters and expected traffic patterns, crossing traffic is not modeled. A preliminary assessment of AUWS performance can be obtained from this simplified model. Further M&S efforts incorporating multi-directional traffic and other realism enhancements are recommended.

The depth of the AOR is 300 feet with a seabed composed of mud and sand. Weather conditions are fair. On average, seven ships arrive in the AOR per hour,⁸² traveling an average of 15 knots. Five per cent of all contacts are valid threats, so AUWS will encounter an average of eight to nine threats on a given day. The scenario lasts only one day because enemy behavior can be expected to change drastically once AUWS has conducted an engagement. While AUWS may be required to operate for 30 days or more, the scenario simulates the first day in which AUWS has been given authority to prosecute threats autonomously.

The quantity and placement of individual units for each system concept can significantly affect performance results in the given scenario. To account for varying capabilities and weapons capacities within individual units, a more sophisticated rule than simply “X number of units/weapons on station” must be employed. A logical assumption is made to dictate the quantity and placement of the units within each AUWS concept. It is assumed that it is desirable to employ a minimal number of units such that the AOR is fully covered by sensors and the first N threats have a non-zero probability of being successfully prosecuted, where $N > 1$. In other words, the enemy cannot be assured of any initial prosecution gaps or safe passages.⁸³ Utilizing this rule provides a common basis for comparison among all system concepts. It is shown that cost and risk analyses can help determine if it is worthwhile to deploy more units to achieve higher P_d and P_k .

5.1.1.3 V-CAP Model

The V-CAP model utilizes four Killer Units, with two mini torpedoes each, and one Hunter Unit, with eight deployed sensor nodes, to cover the AOR. The layout of the individual units is shown in Figure 5.5. Separation between Killer Units is limited by the torpedo range, resulting in a rich, overlapping sensor field. When a vessel is detected, sensor nodes generate and relay contact reports to the Hunter Unit, which classifies the contact and determines system response. If the contact is classified as a threat, the Hunter Unit sends an engagement order to one of the Killer Units, which engages the threat with one of its mini torpedoes. Since overall

82 United States Department of Energy. *World Oil Transit Chokepoints: Malacca*. Feb. 2011. 12 May 2011 <http://ei-01.eia.doe.gov/emeu/cabs/World_Oil_Transit_Chokepoints/Malacca.html>.

83 For the purposes of this analysis, $N = 2$; however, ambiguity allows flexibility in system development and prevents the enemy from defeating the system by sending two decoy vessels ahead of the actual targets.

weapons capacity (eight torpedoes) is equal to the expected number of threats, only one torpedo is used per engagement.

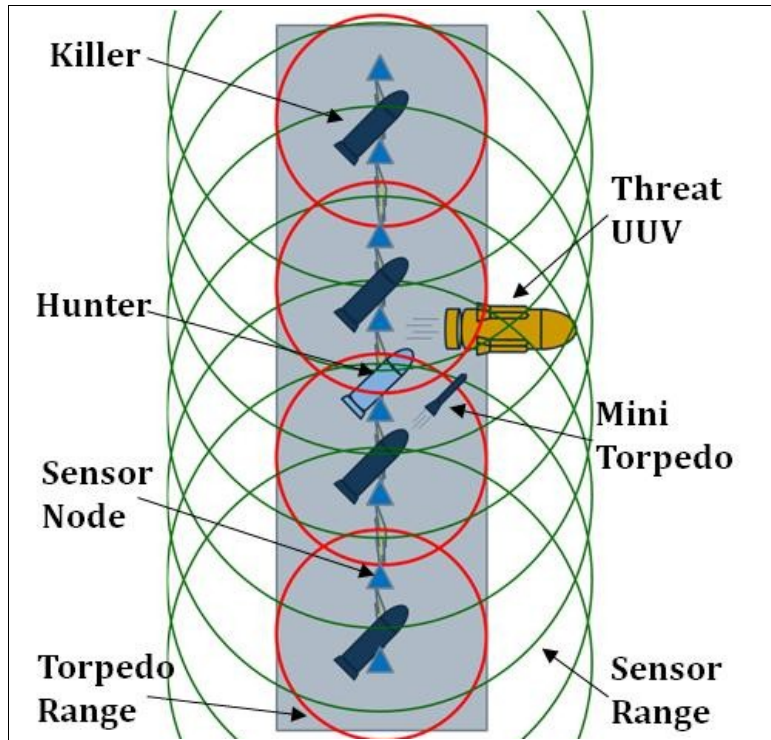

Figure 5.5: V-CAP Engaging Threat UUV

5.1.1.4 LD-UUV Model

The LD-UUV model utilizes one LD-UUV, with four lightweight torpedoes, and 16 paired sensor nodes cover the AOR. The 'X' pattern shown in Figure 5.6 is dictated by communication and detection ranges of the sensor nodes, while minimizing communication time to the LD-UUV. The 'X' layout also permits improved confidence due to simultaneous signal processing, as the sensor pairs are aligned with a perpendicular component to vessel traffic.

The sensor nodes are designed to have group-based decision making capabilities. Working together, the nodes compare sensor data and assessed confidence levels to determine if a threat truly exists and whether a message needs to be sent to the LD-UUV. A single node cannot make a threat determination on its own. When a potential threat is detected, a message is sent to the LD-UUV, with each node along the way contributing to the threat determination. If

the threat is determined to be valid,⁸⁴ the system engages with one of its torpedoes, which have sufficient range to cover the entire AOR.

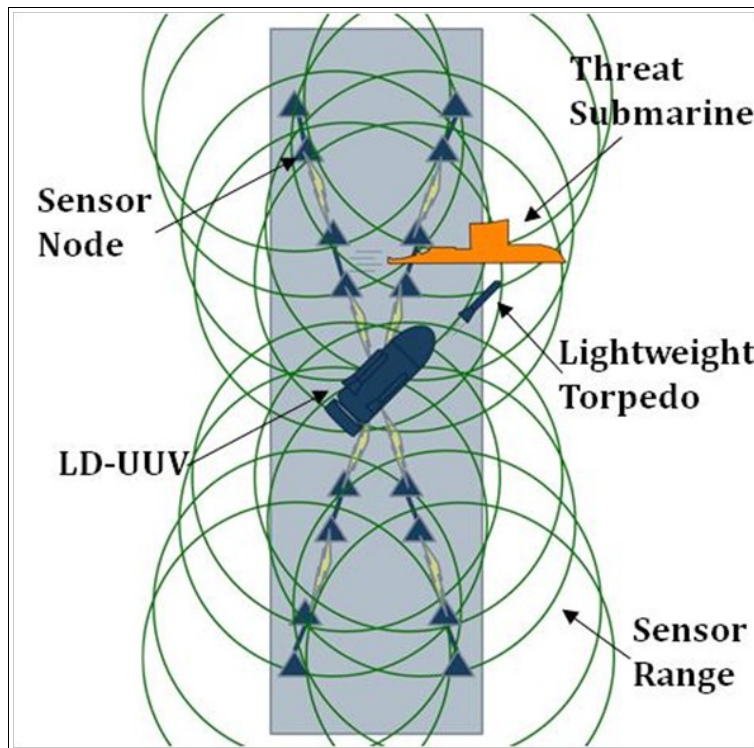

Figure 5.6: LD-UUV Engaging Threat Submarine

5.1.1.5 Glider Model

The Glider model utilizes 17 Gliders to cover the AOR. The most critical driving factor in system layout is the maximum speed of two knots. Intercept of much faster moving targets is difficult without relatively dense detection and prosecution barriers, as shown in Figure 5.7. The front line (detection barrier) detects approaching contacts, makes a threat determination, and, if necessary, sends an engagement order to the best positioned Glider in the back line (prosecution barrier). This process allows prosecuting Gliders maximum time to conduct their intercept. Since contacts transit the AOR from both directions, each line performs both functions depending on the direction the threat is headed. The limited distance that a Glider can pursue a threat helps maintain network integrity until the Glider successfully intercepts and detonates.

⁸⁴ In the model, all threat messages that reach the LD-UUV are valid; however, non-threats sometimes generate threat messages, with decreasing probability as more nodes contribute to the message. This simulates the decision making process of LD-UUV and assesses its impact on internal communications, without introducing prosecution error.

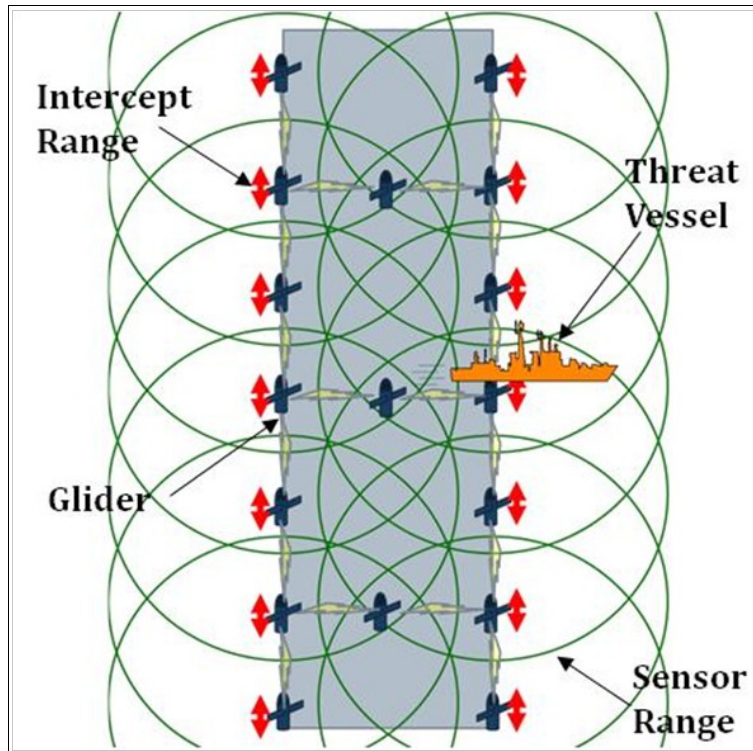

Figure 5.7: Glider Engaging Threat Surface Vessel

The maximum intercept range of 0.55 NM is determined from the Approaching Target Model,⁸⁵ which can be found in Appendix F. Since the Gliders are mobile, it is not necessary to place a Glider every 0.55 NM. Each Glider conducts a barrier search along a 1.43 NM⁸⁶ segment of the line. Barrier search provides a marginal kinematic enhancement factor because the Glider speed is so low compared to the target speed,⁸⁷ but it does satisfy the requirement to deny guaranteed safe passage to initial threats by constantly shifting the prosecution gaps.

Once a Glider successfully intercepts a threat, its warhead detonates and it is removed from the network. Gliders redistribute themselves to heal the network and avoid coverage gaps; however, overall system performance degrades as Gliders are lost.

5.1.1.6 Squid Model

The Squid model utilizes 130 nodes (129 Weapons, 1 Comms) to cover the AOR. The pseudo-random nature of artillery deployment or high altitude air drop is modeled as random

⁸⁵ Eagle, James. *Naval Tactical Analysis Lecture Notes*. Monterey: Naval Postgraduate School, 2009. 9.

⁸⁶ Seven equal sections of 10 NM. Seven Gliders per line is the minimum number required to keep Gliders in communication range when they are evenly spaced.

⁸⁷ Eagle, James. *Naval Tactical Analysis Lecture Notes*. Monterey: Naval Postgraduate School, 2009. 5.

scattering (uniform distribution) throughout the AOR. The model determines which nodes can communicate with each other and determines the shortest path to the Comms Node for each. Nodes that cannot communicate with any other node are considered out of network and are not used for detection and prosecution. Since random scattering cannot produce full coverage of the AOR with 100% certainty, a 99% probability of full coverage is accepted. This probability is achieved with 130 nodes, of which 126 are in network on average. After 130 nodes, marginal gains in coverage diminish rapidly, as shown in Figure 5.8.

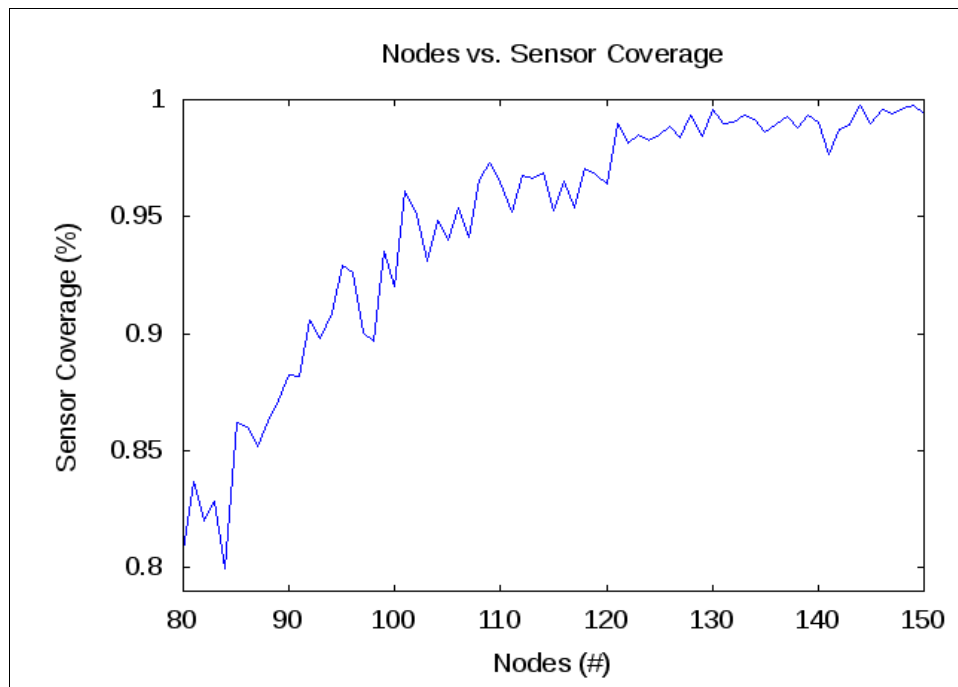

Figure 5.8: Average Sensor Coverage vs Squid Nodes Deployed

When a Weapons Node detects a contact, it sends a contact report to the Comms Node, as shown in Figure 5.9. The Comms Node makes the threat determination and sends engagement orders to the nodes in best position for engagement. Weapons Nodes engage threats by releasing positively buoyant limpet explosives, which attach magnetically to the threat hull. In the model, Weapons Nodes release one explosive per target to maintain follow-on prosecution capabilities.

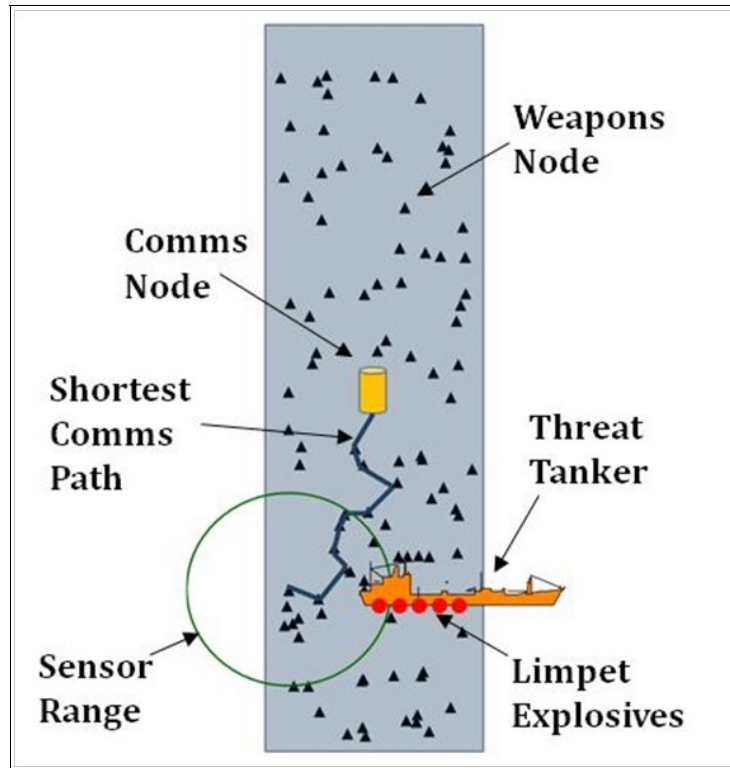

Figure 5.9: Squid Engaging Threat Tanker

5.1.1.7 Modeling and Simulation Results

Table 5.1 summarizes the modeling and simulation results for the four system concepts. Values shown are 95% confidence intervals.

Table 5.1: Modeling and Simulation Results

	Avg MCT (min)	P_d	P_k
Glider	13.3-15.0	0.74-0.75	0.16-0.22
LD-UUV	2.9-3.1	0.80-0.81	0.33-0.43
Squid	3.5-3.7	0.97-0.99	0.07-0.09
V-CAP	4.5-4.7	0.80-0.82	0.54-0.65

From a communication perspective, LD-UUV outperforms the other system concepts in its ability to send a message to an external network quickly. The slightly shorter MCT compared to Squid and V-CAP is primarily due to LD-UUV's use of fiber optic cables between pairs of sensor nodes. This method of communication is much faster than acoustic modem; however, the increased space requirements and complexity in deployment creates a tradespace and limits the

amount of cable that can be utilized. Glider has a considerably longer MCT because each Glider must surface to communicate externally. Without using its one-time terminal boost, this is a time consuming maneuver.⁸⁸

Squid has the best detection capability, with nearly 20% higher P_d than the nearest competitor. This is a result of Squid's use of many independent sensors. Significant sensor redundancy and overlap occurs when nodes are deployed randomly while trying to maintain the requirement of 99% probability of coverage within the AOR.

V-CAP achieves the highest P_k , arguably the most important MOP as it involves elements of communication, detection, and prosecution. A threat must be detected and a message must be communicated to a C2 node before it can be prosecuted. V-CAP's superior prosecution performance is attributed to a sufficient inventory of capable weapons. Each mini torpedo is capable of conducting a mission kill and there are enough on station to handle the average number of threats expected. LD-UUV utilizes a highly effective lightweight torpedo, but it only carries enough to engage half the expected number of threats. Another LD-UUV would be required if more than four engagements are expected. Squid has an abundance of weapons on station, but each one is extremely limited in range and destructive capability. In fact, Squid achieves less than 10% P_k even with the assumption that all limpet explosives successfully attach to their target. Glider suffers in prosecution performance not only because the system degrades as Gliders are lost to engagements, but also because of its limited intercept capability. Notably, Glider's probability of killing the first threat encountered is only 30%, assuming that the blast successfully damages the threat hull (or propeller, rudder, etc.).

V-CAP's superior performance of 54-65% P_k is not necessarily acceptable for fleet operations. Unlike current USW platforms, however, V-CAP can be easily scaled up to improve performance in the given mission. Consider, for example, a V-CAP system consisting of eight Killer Units and two Hunter Units employed to accomplish the mission in the modeling scenario. Since there are now 16 torpedoes on station, assume that each threat can be engaged twice if necessary. This scaled up V-CAP system achieves a P_d of 91-93% and a P_k of 89-96%, certainly an acceptable level for current warfare systems. Cost- and risk-effectiveness analyses will show

⁸⁸ It may be possible to design a recharge capability for the terminal boost, but that is left for further analysis.

that this comparable performance to current systems is achievable at a fraction of unit cost of system deployed, which can be considered a measure of operational risk.

The results of modeling and simulation provide a means to discriminate system concepts and also operational insights that could be widely applied. Insights gained from the results of modeling and simulation are further discussed after considering the results of other analyses.

5.1.2 Endurance Analysis

Undoubtedly, endurance is a primary concern for AUWS. Aside from the ISR and deterrent value in persistent forward presence, logic dictates that higher endurance will provide a greater force multiplier by freeing up manned assets for other operations. There are many different ways to measure endurance, including total power draw by mission profile, nominal recharge rates, etc. Since the four selected alternatives have different methods of employment, it is difficult to compare specific performance variables head-to-head. For instance, LD-UUV requires power to transit in and out of the region, while Squid is air dropped and/or artillery launched into the operational area and requires no power for maneuver. The effect of a hybrid mono-propellant combustion engine with electric drive capability (V-CAP) must be effectively compared to propulsion via variable buoyancy and control surfaces (Glider).

5.1.2.1 Methodology

For the above reasons, the specific number of days each concept can operate on a single sortie is the simplest way of ensuring the system meets baseline requirements while providing a common performance value to analyze. Specifically, the endurance of a single representative unit (one Glider, Squid Node, V-CAP Hunter Unit, or LD-UUV main vehicle) is analyzed in the same scenario used for modeling and simulation. A safe standoff range of 50 NM for deployment and recovery platforms is also imposed. To arrive at an endurance value, some scoping and bounding assumptions are made. Below is a list of assumptions and associated rationales.

- All four concepts utilize passive sonar systems for sensing functions. Understanding that the physical size (and theoretical power draw) of the various sonar suites may vary, the power draw is assumed to be the same for all concepts and is assumed to be constant from the moment of deployment to the moment of recovery/neutralization. For concepts

that use EO/IR sensors, the overall impact to power is considered negligible because those sensors are primarily used for target confirmation, an infrequent task.

- All four concepts utilize acoustic modems for internal communications and line of sight RF or Iridium satellite mobile communications for external transmission and reception. Understanding that the size, transmission range and bandwidth of the respective systems would determine the required power draw, three of the four concepts are assumed to utilize identical systems with identical power draws that are operating continuously at a constant draw from the moment of deployment to the moment of recovery/neutralization. LD-UUV is assumed to use 75% of the baseline power draw for communications to account for its use of intelligent sensor nodes that do not transmit all messages. Overall communication and sensor power draw is assumed to be 0.5 watts for V-CAP, Glider, and Squid, and 0.375 watts for LD-UUV.^{89 90}
- Required propulsion power for V-CAP and LD-UUV is determined by calculating the estimated electrical power required to propel the system given physical specifications and a hydrodynamic drag coefficient of 0.2 (derived in Appendix F). A total value for required propulsion power is calculated by multiplying the power required by the amount of time propulsion will be required for a 30 day period to include inbound and outbound transits and projected maneuver required by mission profile. Glider is assumed to use a negligible amount of its own energy supply for propulsion, much like the Slocum Thermal Glider,⁹¹ and Squid does not have propulsion capabilities.
- To produce endurance in days, the overall percentage of energy required to complete a 30 day mission is divided by 30 days to produce a predicted total number of days the system can operate on a single energy store.
- Energy capacity is estimated by multiplying a given energy density (J/kg) for a particular power source by the mass of the energy storage system, assuming 20% of the concept's mass can be attributed to energy storage. V-CAP uses 50% battery and 50% mono-

89 DSPComm Inc. "AquaComm: Underwater Wireless Modem." 2009. *DSPComm.com*. 2 May 2011 <http://www.dspcomm.com/products_aquacomm.html>.

90 RESON Inc. "Hydrophone TC4032." 2005. *RESON.com*. 5 May 2011 <<http://www.reson.com/wp-content/uploads/2010/12/TC4032.pdf>>.

91 Teledyne Webb Research. "Thermal Glider." 2010. *WebbResearch.com*. 5 May 2011 <<http://www.webbresearch.com/thermal.aspx>>.

propellant, Squid uses 90% battery and 10% ultra-capacitor, Glider uses only fuel cells, and LD-UUV uses only batteries.

- Lithium ion battery: 460 kJ/kg⁹²
- OTTO Fuel II mono-propellant: 350 kJ/kg (derived in Appendix F)
- Ultra-capacitor: 3.6 kJ/kg⁹³
- Magnesium-air fuel cell: 1800 kJ/kg⁹⁴
- Total system mass is determined by multiplying a density of 1298 kg/m³ derived from a heavyweight Mk-48 ADCAP torpedo,⁹⁵ by the estimated volume (assuming the shape is a cylinder of known length and radius) of each concept.
- The density of seawater is assumed to be 1030 kg/m³.⁹⁶

A threshold value is set at 30 days, in accordance with operational requirements and current guidance, with a goal value at 180 days, which is the maximum anticipated annual operational usage for a particular unit. For a sample calculation of endurance, refer to Appendix F. Overall endurance analysis results are shown in Table 5.2. For ease of analysis, values are calculated using SI units and then converted to US customary units where appropriate.

92 AllAboutBatteries.com. "Battery energy storage in various battery types." 12 January 2011.

AllAboutBatteries.com. 5 May 2011 <http://www.allaboutbatteries.com/contact_us.html>.

93 Woodbank Communications Ltd. "Battery Performance Characteristics - How to specify and test a battery." 2005. *mpoweruk.com*. 3 May 2011 <<http://www.mpoweruk.com/performance.htm>>.

94 Woodbank Communications Ltd. 1.

95 IHS Global Limited. "Mk 48 ADCAP." 27 July 2010. *Janes.com*. 3 May 2011

<http://search.janes.com.libproxy.nps.edu/Search/documentView.do?docId=/content1/janesdata/yb/juws/juws0501.htm@current&pageSelected=allJanes&keyword=Mk 48 torpedo&backPath=http://search.janes.com/Search&Prod_Name=JUWS&>.

96 Raymond A. Serway, Robert J. Beichner and John W. Jewett. *Physics for Scientists and Engineers*. New York City: Saunders College Publishing, 2000.

Table 5.2: Endurance Analysis Results

	V-CAP	LD-UUV	Glider	Squid
Length (m)	5.791	5.791	1.8	0.33
Diameter (m)	0.532	2.032	0.254	0.155
Speed (m/s)	2.57	2.57	0	0
Distance Propelled in 30 days (m)	209646	240760	0	0
Area (m²)	0.222	3.243	0.051	0.019
Propulsion Duration (s)	81574	93681	0	0
Propulsion Power Draw (W)	389	5670	0	0
Propulsion Energy Used (J)	31703207	531159673	0	0
Sensor Energy Used (J)	1296000	972000	1296000	1296000
Mass (kg)	1671	24377	118	8
Energy Storage Mass (kg)	334	4875	24	2
Energy Capacity (J)	135344752	2242685484	42619369	669807
Capacity Expended (%)	0.244	0.237	0.03	1.935
Predicted Endurance (Days)	123.044	126.436	986.559	15.505

5.1.2.2 V-CAP Endurance

The V-CAP Hunter Unit's length and diameter are estimated to be equal to that of a Raytheon Mk 48 ADCAP torpedo,⁹⁷ 18 feet by 21 inches. It is important to note that the modular feature of V-CAP allows for lengths from 9 to 18 feet, which significantly affects predicted endurance. The impacts of this modularity are discussed later in detail. Speed for transit and maneuver is estimated at five knots. Distance traveled is estimated to consist of a 50 NM inbound transit from deployment position to the center of the individual unit's operational area, a 13 NM transit through the AOR to deploy sensor nodes, and a 50 NM outbound transit for recovery following completion of operations. Given this data, the Hunter Unit is predicted to have an endurance of 123 days, to include inbound transit, operations, and outbound transit.

5.1.2.3 LD-UUV Endurance

The LD-UUV is estimated to be 19 feet long, which makes it compatible with the Multiple All-up-round Canisters that currently launch Tomahawk missiles on submarines. The diameter is estimated at 80 inches to fit the 87 inch diameter tubes on existing SSGNs and future

97 IHS Global Limited. "Mk 48 ADCAP." 27 Jul. 2010. *Janes.com*. 3 May 2011
http://search.janes.com.libproxy.nps.edu/Search/documentView.do?docId=/content1/janesdata/yb/juws/juws0501.htm@current&pageSelected=allJanes&keyword=Mk 48 torpedo&backPath=http://search.janes.com/Search&Prod_Name=JUWS&.

SSNs.⁹⁸ Speed is estimated at five knots. Distance traveled is assumed to be the same 50 NM inbound and outbound transits as V-CAP, but with an “hourglass” maneuver pattern covering the whole of the 10 NM by 3 NM AOR to deploy sensor nodes. Using the same methodology as V-CAP, LD-UUV is predicted to have an endurance of 126 days.

5.1.2.4 Glider Endurance

The basic dimensions of Glider are essentially those of the Teledyne Webb Research Slocum Thermal Glider,⁹⁹ but scaled up 20% to accommodate weaponry and a terminal maneuver system, making it 5.9 feet long and 10 inches in diameter. Speed and distance traveled are not considered because electrical power is not being used to provide propulsion. For that reason, no power calculation is made for the work required to cover the required distance during the 30 day mission. The only power draw comes from the sensors and communications suite. This, combined with a relatively large battery, gives Glider a predicted endurance of 986 days, or nearly 3 years which is consistent with projections for the Slocum Thermal Glider.¹⁰⁰

5.1.2.5. Squid Endurance

Squid Weapons Nodes are sized to fit three to a round within Lockheed Martin’s LRLAP (155 millimeters diameter by 2.2 meters in length)¹⁰¹ or a similar projectile. For this reason, a Squid node is estimated at 155 millimeters diameter and 0.33 meters length such that less than half of the LRLAP will consist of Squid nodes. The introduction of Squid nodes will obviously reduce the range of LRLAP, but since the projectile can be launched over 70 NM, it is assumed Squid can be effectively deployed from the 50 NM standoff range. Speed and distance traveled are both zero, because Squid does not have any propulsion capabilities. Similar to Glider, power draw is from sensors and communications systems only. Given this information, Squid nodes are predicted to have an endurance of 15 days, well short of the 30 day requirement. The small size, and low weight, of the Squid nodes leads to a very small battery, and therefore low capacity.

98 Pike, John. "SSN-774 Virginia-class NSSN New Attack Submarine." 5 Sept. 2008. *GlobalSecurity.org*. 1 May 2011 <<http://www.globalsecurity.org/military/systems/ship/ssn-774-spiral-2.htm>>.

99 Teledyne Webb Research. "Thermal Glider." 2010. *WebbResearch.com*. 5 May 2011 <<http://www.webbresearch.com/thermal.aspx>>

100 Teledyne Webb Research 1.

101 Lockheed Martin Corporation. "Long Range Land Attack Projectile (LRLAP)." 2009. *LockheedMartin.com*. 4 May 2011

5.1.2.6 Endurance Analysis Results

Strictly from an endurance perspective, Glider outperforms the other three system concepts by far. The excellent endurance of the gliding UUVs explains the popularity of this technology and is a valid reason for continued research. The relative closeness of V-CAP and LD-UUV with regard to endurance is expected, as the mission profiles are very similar, but V-CAP benefits slightly from a smaller cross sectional area. Squid nodes, as modeled, are unable to meet the 30 day endurance requirement. This is significant because the sensor nodes employed by V-CAP and LD-UUV are designed similarly. An improvement in energy capacity or efficiency may be needed for these two concepts to meet the endurance requirement. Another option would be to deploy two Hunter Units or LD-UUVs so that half of the sensor nodes could be activated for 15 day periods each, covering the required 30 days.

5.1.3 Maneuverability Analysis

Several different MOEs and MOPs exist to measure the facility and effectiveness of each concept with regard to their ability to deploy (or be deployed), transit, navigate, and be recovered (as applicable). Specifically, deployability and recoverability do not lend themselves to quantitative analysis as the values selected for each alternative would ultimately be too subjective to analyze. Modeling and simulation does consider the direct impact of maneuverability on system performance. To provide a fair and universal comparison of the effectiveness of the different systems regarding deployment and recovery, the system concepts are analyzed qualitatively based on their ability to be deployed and recovered by both contemporary and future platforms. This qualitative analysis is based on the highly subjective nature of determining the relative importance of these particular facets of maneuverability.

5.1.3.1 Capability for Deployment by both Contemporary and Future Platforms

To compare the deployment capability of AUWS concepts, consider that there are effectively three types of platforms that can be utilized for system delivery: airborne, surfaced, and submerged assets. Based on the design of each system concept, some delivery assets may not be feasible. To assign a quantitative ranking to a qualitative discussion, a score of *zero* to *three* is assigned to each concept based on the number of platform types capable of accommodating AUWS. If a concept can conceivably be launched from all three types of platforms, it receives a

score of *three*. A concept that can only reasonably be deployed by two types of platforms receives a score of *two*, and so forth. If a concept can be deployed by an asset on a limited basis, or with significant restrictions, it is given a *0.5* for that particular platform type. Table 5.3 shows the results of this analysis.

Table 5.3: Deployment Scoring

Capability for Deployment by both Current and Future Platforms		
Threshold	1	Score is based on the number of platform types capable of launching each alternative.
Goal	3	
V-CAP	2.5	
LD-UUV	1.5	
Glider	1.0	
Squid	1.0	

A threshold value of *one* is chosen, since a system that cannot be deployed from any type of asset is inherently a failure. A goal of *three* is chosen to represent the full range of options without giving any unwarranted benefit to units incapable of achieving deployment from all platform types.

V-CAP is readily deployable by submarines without modification due to the similarity in design to a standard Mk 48 torpedo. The modular construction of the V-CAP unit allows for the inclusion of fewer mission sections, resulting in a shorter overall length and lighter weight, allowing airborne assets such as the P-8 to carry V-CAP. Surface ships do not have 21” diameter torpedo launchers, but they may deploy V-CAP units over the side with standard crane or davit equipment. Based on this discussion, V-CAP receives a score of *2.5*.

LD-UUV is sized to fit in the 87” diameter tubes of the current SSGN class and the future blocks of Virginia class SSNs. The large size and weight makes airborne deployment improbable. Surface ships, with a specialized crane installed, are capable of deploying LD-UUV. Given an inability to air drop and limitations on surface deployment, LD-UUV receives a score of *1.5*.

Glider is a small UUV with relatively large control surfaces that currently are not designed to fold away due to weight and complexity restrictions. This design feature results in no readily available method to launch these units from a submarine at depth. Airborne deployment is also questionable, as dropping a Glider unit from a P-8’s operational altitude, even with a retarding device, would most likely result in damage to the sensitive control surfaces and

ballasting systems that are critical to the Glider’s mobility. Surface ships can easily drop Glider units over the side. In fact, small teams of sailors can launch Gliders by hand, without the need for installed cranes or davits. The lack of submerged or airborne deployment options gives Glider a score of *one*.

Squid units can only be mounted on the non-reloadable external six inch countermeasures pods on existing SSNs. Even if that system were utilized, the small number of nodes that could be delivered by a submarine would result in very little added value. Air dropping Squid is definitely feasible based on the compact, durable, and expendable nature of the nodes. Surface launch via drops over the side or artillery launch are both reasonable modes of delivery. Squid is able to deploy from two platform types; however, since the Comms Node must be deployed separately, Squid is docked one point for requiring two modes of deployment, resulting a score of *one*.

5.1.3.2 Capability for Recovery by both Contemporary and Future Platforms

The same methodology used to analyze deployment is used to evaluate recovery. A score is assigned based on the number of types of units capable of feasibly recovering each concept.

Table 5.4 shows the results of the analysis.

Table 5.4: Recovery Scoring

Capability for Recovery by both Contemporary and Future Platforms		
Threshold	0	Score is based on the number of platform types capable of recovering each alternative. 3 = surface, subs, and air. 2 = 2 of 3 platform types. 1 = 1 of 3 platform types. 0.5 = significant limitations on a particular platform type
Goal	3	
V-CAP	3	
LD-UUV	1.5	
Glider	2	
Squid	0	

A threshold value of *zero* is chosen in this case because not all concepts are designed to be recovered. Assigning this score avoids penalizing Squid needlessly, since recovery in and of itself is not assessed as a critical need. A goal value of *three* is assigned to prevent awarding full credit to concepts that are not recoverable by all platforms.

V-CAP may be recovered via torpedo tube by a submarine. Lightweight (air dropped) variants of V-CAP may be recovered by helicopter. Surface ships are generally capable of

recovering all variants of V-CAP. With the capacity of recovery by submerged, surfaced, and airborne assets, V-CAP receives a score of *three*.

LD-UUV may be recovered by a submarine and reloaded into a MAC. Airborne recovery is infeasible due to LD-UUV's large size and heavy weight. Surface ships equipped with heavyweight cranes are capable of recovering LD-UUV. Without airborne recovery and limitations on surface recovery, LD-UUV scores a *1.5*.

Glider cannot reasonably be retrieved by a submarine at depth because its control surfaces cannot fit into a torpedo tube opening. Airborne or surface ship recovery would be fairly easy to accomplish once the unit is surfaced. Glider therefore receives a score of *two*.

SQUID is non-recoverable by nature of its design, meaning no units may recover it. This results in a score of *zero*. Non-recoverability is not automatically detrimental, especially if the per unit costs are low enough where the individual nodes become expendable. That is not considered as part of the analysis here, but will factor into the cost analysis discussed later.

5.1.4 OPSEC Analysis

Capability to Avoid Detection is the metric used to evaluate the AUWS OPSEC function. It is challenging to estimate the designs, frequencies, and signatures of conceptual systems. In order to provide useful comparisons, some of the factors that contribute to detection avoidance are analyzed in a binary fashion. All four system designs lend themselves to "yes" or "no" answers for each factor, such that a score of *one* can be attributed for a "yes" and a score of *zero* can be given for a "no" response. When the results are averaged assuming an equal weight for each factor, a final score between *one* and *zero* can be assigned to each concept. Table 5.5 shows the results of the analysis.

Table 5.5: Detection Avoidance Scoring

Capability to Avoid Detection				
Threshold	0	Values are the average value of an equally weighted binary analysis of four factors, shown below. 0 = no, 1 = yes.		
Goal	1			
	V-CAP	LD-UUV	Glider	Squid
Evasion Capability	1	1	0	0
Lack of Exploitable Signature	1	1	0	1
Lack of Compromising Posture	1	1	0	1
Covert Deployability	1	1	1	0
Total Score	1	1	0.25	0.5

A threshold value of *zero* is assigned to reflect a complete inability to avoid detection. A goal of *one* is assigned to give full credit to concepts meeting all detection avoidance criteria.

Evasion Capability refers to a concept’s use of organic propulsion and maneuver capability to evade a searching threat or a potentially compromising neutral vessel. V-CAP and LD-UUV both maintain the ability to employ evasive maneuvers via a monopropellant combustion engine and electric drive, respectively. For this reason, they score a *one* for Evasion Capability. Glider’s high-speed terminal homing engine can provide short duration evasion, but following fuel burnout after 20 seconds, no fuel will remain to allow the Glider unit to engage, effectively providing a mission kill for that particular unit. With no dedicated means to evade, Glider scores a *zero*. Squid is immobile, and therefore also receives a *zero*.

Lack of an Exploitable Signature refers to the ability of a concept to adjust its emissions (both in communications and operational noise from mechanical and electrical sources) to avoid detection. V-CAP and LD-UUV can both change their emissions control (EMCON) status by reeling in their communications buoys to minimize the threat of visual or electronic support measures (ESM) detection. Additionally, both systems can proceed to the bottom and secure operational noise to minimize emissions. The Squid Comms Node can also reel in its communications buoy to reduce observables, and it has no moving parts, further minimizing exploitable signatures. These three concepts receive a score of *one*. Glider must surface to conduct communication, providing greater visual and ESM observables. Furthermore, Glider must continuously operate ballasting pumps and control surfaces to maneuver, resulting in incessant mechanical and electrical transients. Glider therefore receives a score of *zero*.

Lack of Compromising Posture is somewhat of a corollary to the Lack of Exploitable Signature metric, but it deals specifically with each concept's exploitable configuration under normal operations. For example, V-CAP, LD-UUV, and Squid all maintain retractable communications buoys that can be rapidly reeled in to minimize the threat of detection. Otherwise, the units are stationary and silent, granting each a score of *one*. Glider must surface during communications operations, and it cannot rapidly dive to avoid detection. Not only is a larger RCS displayed due to the increased percentage of the UUV is exposed, but Glider cannot rapidly reduce its RCS by diving quickly. Due to this vulnerability, Glider receives a score of *zero*.

Covert Deployability refers to the ability to insert each system concept into an operational area without alerting threat contacts, sidestepping the whole issue of a detection threat. V-CAP and LD-UUV are both capable of long distance underwater delivery from submarines, granting them a score of *one*. Glider has marginal propulsion capability, but it can reliably travel long distances to provide a covert standoff range for deploying assets. Glider is a covert, although not rapid, deployable system so it receives a score of *one*. Squid must be air dropped or launched via artillery fire, both of which are likely to illicit the attention of units operating in the deployment area. For this reason, Squid receives a score of *zero*.

Averaging the scores for the four areas, a final value for the Capability to Avoid Detection for each concept is reached. V-CAP and LD-UUV tie by meeting all subcategory requirements, resulting in an overall score of *one* for each. Squid achieves an average score of *0.5* placing it third, and Glider comes in last with a score of *0.25* with only its covert deployment capability contributing to OPSEC.

5.1.5 Performance Analysis Results

Table 5.6 is a compilation of the performance analysis results by MOE.

Table 5.6: Summary of Performance Analysis Results

	Threshold	Goal	V-CAP	LD-UUV	Glider	Squid
Capability to Operate for Minimum of 30 Days (days)	30	180	123	126	987	16
Average Data Message Completion Time (minutes)	10	0	4.61	3.01	14.13	3.60
Capability for Deployment by both Current and Future Platforms (# of platforms)	1	3	2.5	1.5	1.0	1.0
Capability for Recovery by both Contemporary and Future Platforms (# of platforms)	0	3	3.0	1.5	2.0	0.0
Probability of Detection (%)	0	1	0.81	0.81	0.75	0.98
Probability of Kill (%)	0	1	0.59	0.38	0.19	0.08
Capability to Avoid Detection (rating)	0	1	1.00	1.00	0.25	0.50

5.1.6 Overall Measure of Effectiveness

To compare the performance of the four concepts, a single value representing the overall effectiveness of each concept must be developed. Normalizing and averaging the performance results alone does not provide a realistic Overall Measure of Effectiveness (OMOE). To reach a true OMOE, an Analytical Hierarchy Process is used to determine the weighting of stakeholder needs. Those stakeholder needs are referenced to functions, and those functions are referenced to the MOEs used to judge performance by a Quality Functional Deployment (QFD) for the purpose of deriving weightings for each MOE. Weighted, normalized performance results are then summed to calculate an OMOE value for each alternative.

A sensitivity analysis is then performed to ensure that the resultant weights do not adversely skew the results. Upon completion of the sensitivity analysis and any adjustments deemed necessary by those results, a final OMOE exists for each alternative that can be then used, along with the results of the cost and risk analyses, to make a final system recommendation.

5.1.6.1 Analytical Hierarchy Process

To start the process, the seven need areas are compared to each other using a standardized ranking scale. The need areas are listed below:

1. Threat Discrimination
2. Detection Avoidance
3. Adjustable Autonomy
4. Persistent Forward Presence
5. Enemy Prosecution (manned and unmanned)
6. Operational Picture Development
7. Platform Independence

Table 5.7 shows the need area comparison while Table 5.8 provides an explanation of each value in the ranking system.

Table 5.7: Need Area Comparison

More Important Need Area	Less Important Need Area	Intensity
Threat Discrimination	Detection Avoidance	5
Threat Discrimination	Adjustable Autonomy	1
Persistent Forward Presence	Threat Discrimination	5
Threat Discrimination	Enemy Prosecution (manned and unmanned)	1
Threat Discrimination	Operational Picture Development	2
Threat Discrimination	Platform Independence	5
Detection Avoidance	Adjustable Autonomy	3
Persistent Forward Presence	Detection Avoidance	5
Enemy Prosecution (manned and unmanned)	Detection Avoidance	4
Operational Picture Development	Detection Avoidance	5
Detection Avoidance	Platform Independence	5
Persistent Forward Presence	Adjustable Autonomy	5
Enemy Prosecution (manned and unmanned)	Adjustable Autonomy	5
Operational Picture Development	Adjustable Autonomy	9
Adjustable Autonomy	Platform Independence	1
Persistent Forward Presence	Enemy Prosecution (manned and unmanned)	1
Operational Picture Development	Persistent Forward Presence	3
Persistent Forward Presence	Platform Independence	9
Enemy Prosecution (manned and unmanned)	Operational Picture Development	1
Enemy Prosecution (manned and unmanned)	Platform Independence	9
Operational Picture Development	Platform Independence	9

Table 5.8: The Saaty AHP Rating Scale¹⁰²

Intensity of Importance	Definition	Explanation
1	Equal importance	Two factors contribute equally to the objective
3	Somewhat more important	Experience and judgment slightly favor one over the other
5	Much more important	Experience and judgment strongly favor one over the other
7	Very much more important	Experience and judgment very strongly favor one over the other. Its importance is demonstrated in practice
9	Absolutely more important	The evidence favoring one over the other is of the highest possible validity
2, 4, 6, 8	Intermediate values	When compromise is needed

Using Saaty’s scale, Threat Discrimination, for example, has a rating of *five* over Detection Avoidance, meaning that it is “much more important” and that “experience and judgment strongly favor [Discrimination] over [Detection Avoidance].” These values are derived from Needs Analysis. Validation of these numbers is addressed following discussion of the ensuing pairwise analysis shown in Table 5.9.

¹⁰²Coyle, Geoff. The Analytic Heirarchy Process (AHP). Harlow, 2004. 2.

Table 5.9: Need Area Pairwise Analysis

	Capability	Threat Discrimination	Detection Avoidance	Adjustable Autonomy	Persistent Forward Presence	Enemy Prosecution (manned and unmanned)	Operational Picture Development	Platform Independence	
Capability		1	2	3	4	5	6	7	Weighting
Threat Discrimination	1	1.00	5.00	5.00	1.00	0.20	1.00	2.00	0.151
Detection Avoidance	2	0.20	1.00	3.00	0.20	0.25	0.20	5.00	0.066
Adjustable Autonomy	3	0.20	0.33	1.00	0.20	0.20	0.11	1.00	0.031
Persistent Forward Presence	4	1.00	5.00	5.00	1.00	1.00	0.33	9.00	0.184
Enemy Prosecution (manned and unmanned)	5	5.00	4.00	5.00	1.00	1.00	1.00	9.00	0.266
Operational Picture Development	6	1.00	5.00	9.00	3.00	1.00	1.00	9.00	0.273
Platform Independence	7	0.50	0.20	1.00	0.11	0.11	0.11	1.00	0.029
Column Sum		8.90	20.53	29.00	6.51	3.76	3.76	36.00	1
Lambda Max Calculation		1.26	1.26	0.92	1.23	1.00	1.05	1.03	7.75
Consistency Index									0.125
Random Index (2001) - Saaty									1.32
Consistency Ratio									9%

A simple, or one-way, comparison relates the first need area to the six remaining areas in a pairwise matrix to generate comparative weights for each need. The process shown in Table 5.9 is a comprehensive pairwise analysis wherein each need area is compared to every other need

area to provide a more exact weighting breakdown. Weighting is determined by averaging the normalized values for each comparison. Normalized values are determined for each cell by dividing the value of that cell by the column sum for that cell's column.¹⁰³ The following equation shows the process by which a weight for Threat Discrimination is derived.

$$\text{Weighting} = \frac{\frac{1}{8.9} + \frac{5}{20.53} + \frac{5}{29} + \frac{1}{6.51} + \frac{0.2}{3.76} + \frac{2}{36}}{7} = 0.151$$

This process can lead to inconsistencies in rankings; for example, in a simple three-way comparison between items A, B, and C, it follows that if A is better than B, and B is better than C, that A should be better than C. Inadvertently giving deference to C over A can be readily identified, but the process becomes more complex as more items are considered.¹⁰⁴ In this case, the presence of seven need areas results in a total of 21 comparisons. To maximize consistency, Saaty's random index (1.35 for n = 7)¹⁰⁵ is applied to measure the overall consistency of response. Any value of 10% or less is indicative of acceptable consistency.¹⁰⁶

This consistency ratio is determined by finding the geometric mean of each row. That geometric mean is divided by the sum of all row geometric means to develop a priority vector for each row. The column sum for each column is multiplied by the corresponding priority vector to make a priority row value. The sum of those row values is used to calculate a consistency ratio as shown:¹⁰⁷

$$\text{Consistency Ratio} = \frac{1}{\text{Random Index}} * \frac{(\sum \text{Priority Row}) - n}{(n-1)}$$

The original revision of this pairwise analysis resulted in a consistency index greater than 30%. The values in Table 5.7 reflect the adjustments made to reduce the ratio to the 9%, while satisfying a common sense check and maintaining agreement with priorities identified in Needs Analysis. Figure 5.10 shows the final weighting of each need area.

103 Hahn, Danny. "The Analytic Hierarchy Process." 2007. *INCOSE.org*. 11 May 2011
<http://www.incose.org/sfbac/2007events/071113ahp.pdf>. 1-35.

104 Hahn 1-35.

105 Hahn 1-35.

106 Hahn 29.

107 Hahn 1-35.

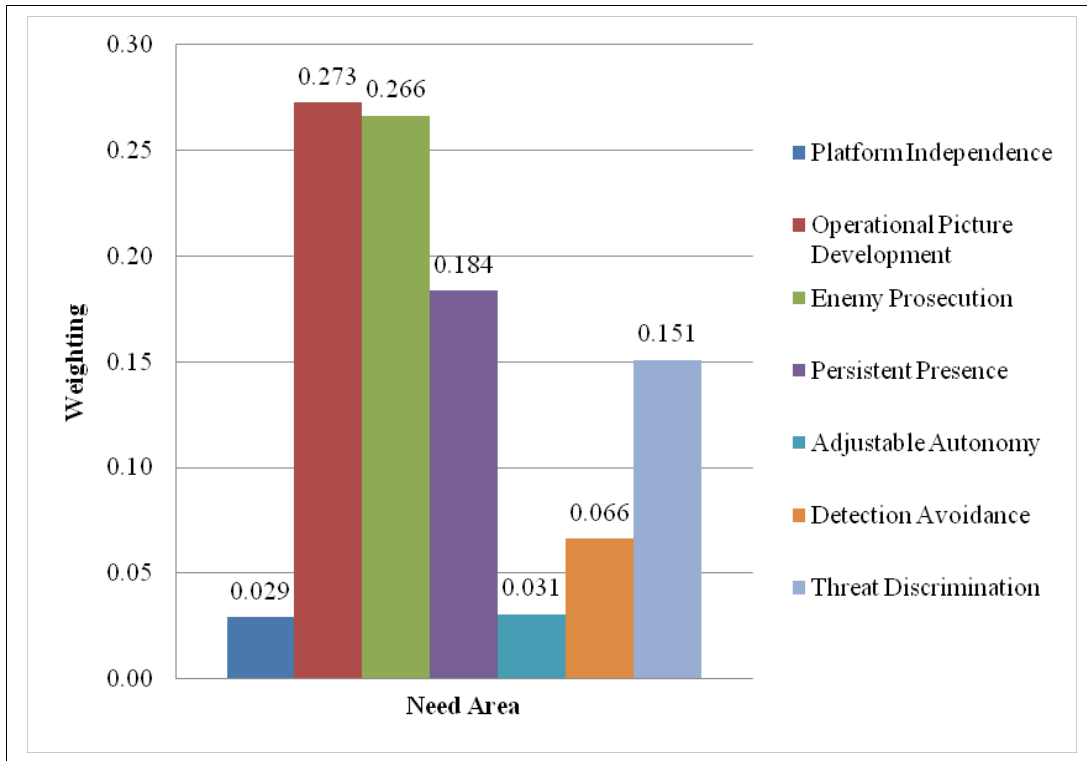

Figure 5.10: Need Area Weighting Results

From Figure 5.10, it is evident that the key needs for AUWS are the ability to develop an operational picture of an AOR, prosecute enemies within that AOR, and to do so while maintaining a persistent forward presence with accurate discrimination capability. These four factors therefore hold the most influence in the analysis of alternatives. Detection avoidance, adjustable autonomy, and platform independence are of a significantly lower value.

5.1.6.2 Quality Functional Deployment

The next step of the Performance Analysis is to derive relative weightings for the seven MOEs to be analyzed given the weighting for the seven need areas derived from the pairwise analysis. A Quality Functional Deployment, a series of transformations using Houses of Quality, is employed to compare Needs to Functions.¹⁰⁸ A House of Quality defines the relationship

¹⁰⁸ Provide Structure function is excluded. Provide Structure is a function defined by the provision of a physical architecture and enclosures to hold the components that execute the other functions of the system. It does not have any bearing on the weighting of the remaining six functions.

between desires and capabilities using affinity values.¹⁰⁹ Table 5.10 shows the first House of Quality.

Table 5.10: House of Quality 1 (Needs to Functions)

	Function	1.2 Provide Power	1.3 Perform C3	1.4 Maneuver	1.5 Perform ISR	1.6 Prosecute	1.7 Provide OPSEC
Capability	Weight						
Threat Discrimination	0.151	<i>1</i>	<i>9</i>			<i>9</i>	<i>9</i>
Detection Avoidance	0.066	<i>1</i>		<i>3</i>			<i>9</i>
Adjustable Autonomy	0.031	<i>1</i>	<i>9</i>	<i>1</i>			<i>1</i>
Persistent Forward Presence	0.184	<i>9</i>	<i>3</i>				<i>1</i>
Enemy Prosecution (manned and unmanned)	0.266	<i>1</i>	<i>3</i>	<i>3</i>	<i>3</i>	<i>9</i>	
Operational Picture Development	0.273	<i>3</i>	<i>9</i>			<i>9</i>	<i>1</i>
Platform Independence	0.029	<i>1</i>	<i>1</i>	<i>1</i>	<i>1</i>	<i>1</i>	<i>1</i>
Weighted Performance		3.016	5.469	1.058	4.642	3.786	1.113
Weighting		0.158	0.287	0.055	0.243	0.198	0.058

The weights determined in the pairwise analysis are listed in bold next to their associated need area. The italicized numbers represent affinity values linking need areas to functions. A value of *nine* indicates a strong affinity between the need and function. A value of *three* indicates a moderate affinity, a value of *one* is used for a slight affinity and a blank cell (*zero*) is used for no affinity. Affinities are subjective values derived from the needs analysis. The need weights are multiplied by the affinity numbers for each comparison, and then those values are summed to produce a weighted performance for each function. Each individual weighted performance is normalized to the sum of all weighted performances to produce a weighting for each function. The results of the first House of Quality are shown in visual format in Figure 5.11.

109 Blanchard, Benjamin S. and Wolter J. Fabrycky, *Systems Engineering and Analysis*, 4th ed. Upper Saddle River, 2006. 77.

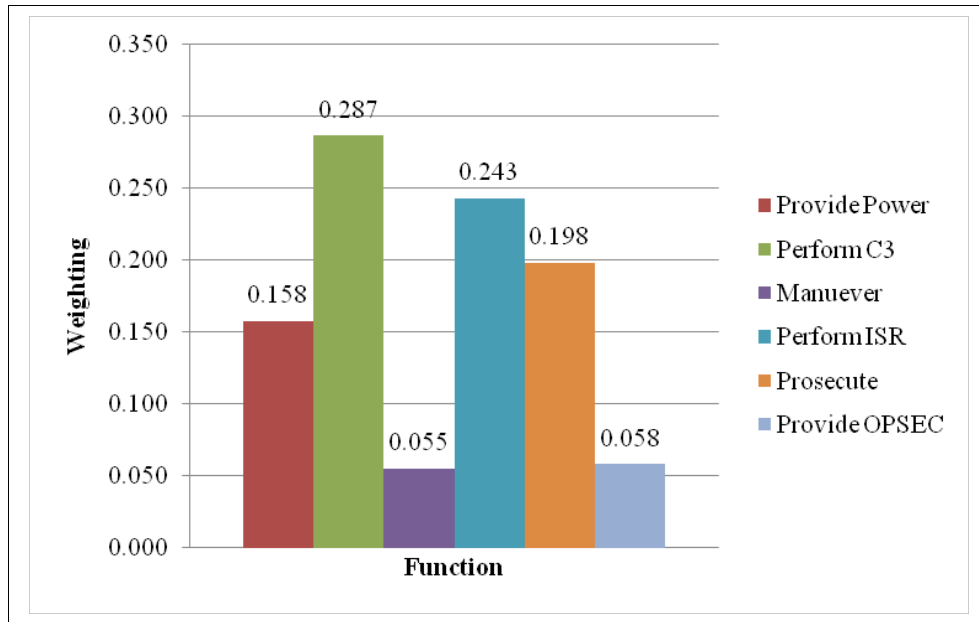

Figure 5.11: Functional Weighting Results

The provided affinity values indicate that Perform C3, Perform ISR, and Prosecute are the most valuable functions, which supports the use of Communications, Sensors, and Weapons systems as the three critical elements for concept generation. This concurrence provides validation for the affinity values selected. Provide Power ranks fourth, with Maneuver and Provide OPSEC ranking last within a few hundredths of a point of each other. The low prioritization of these functions highlights the importance of considering systems that have little to no maneuvering or evasion capabilities, such as Glider and Squid.

The next House of Quality compares functions to the MOEs selected for analysis, as shown in Table 5.11.

Table 5.11: House of Quality 2 (Functions to MOEs)

		Capability to Avoid Detection	Probability of Kill	Probability of Detection	Probability of Recovery by both Contemporary and Future Platforms	Capability for Deployment by both Current and Future Platforms	Average Data Message Completion Time	Capability to Operate for Minimum of 30 Days	MOE
Function	Weight								
1.2 Provide Power	0.158		<i>1</i>					<i>1</i>	<i>1</i>
1.3 Perform C3	0.287	<i>3</i>	<i>9</i>					<i>3</i>	<i>3</i>
1.4 Maneuver	0.055			<i>9</i>	<i>9</i>				
1.5 Perform ISR	0.243	<i>3</i>	<i>9</i>	<i>3</i>				<i>9</i>	<i>3</i>
1.6 Prosecute	0.198	<i>3</i>		<i>3</i>				<i>9</i>	<i>9</i>
1.7 Provide OPSEC	0.058							<i>3</i>	<i>9</i>
Weighted Performance		3.607	4.927	1.824	0.499	4.992	3.708	2.709	
Weighting		0.162	0.221	0.082	0.022	0.224	0.167	0.122	

Just as in the previous House of Quality, the previously determined functional weightings are listed in the column next to their respective functions. The columns represent the seven MOEs to be analyzed. The italicized numbers are affinity values derived from needs analysis, with *nine* representing a strong affinity, *three* representing a moderate affinity, *one* representing a slight affinity, and a blank cell (*zero*) representing no affinity between the function and MOE. The scores for each MOE are multiplied by the functional weightings to achieve weighted performances, which are then normalized to provide a final weighting for each MOE, which are shown graphically in Figure 5.12.

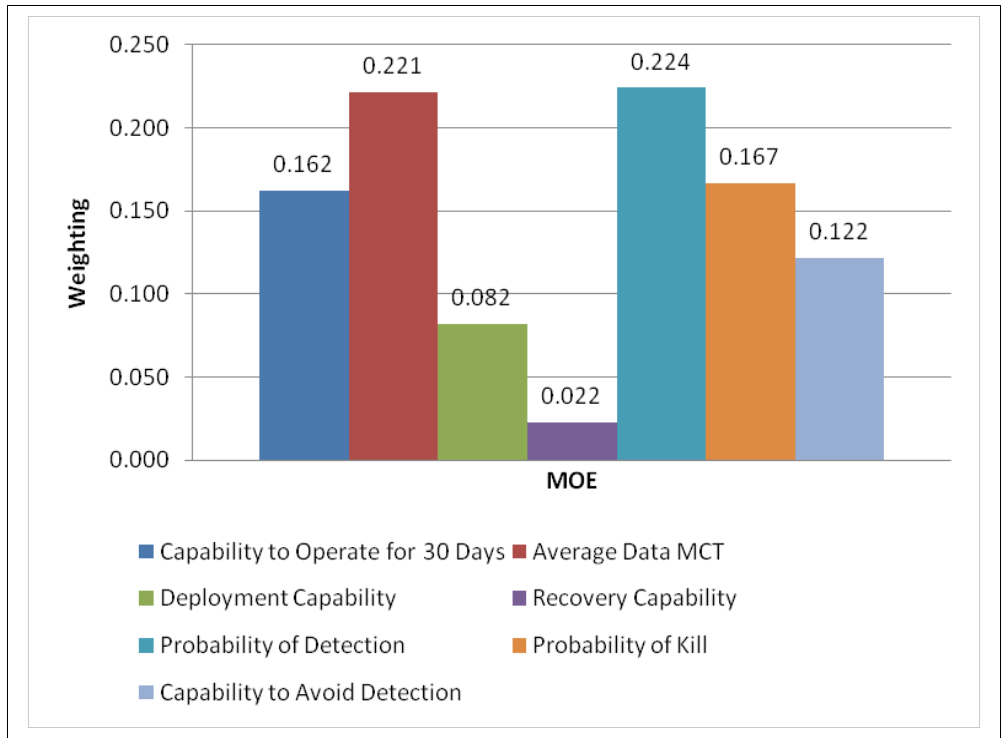

Figure 5.12: MOE Weighting Results

Probability of Detection and the Capability to Transmit Message rank first and second, respectively, with a nominal margin of three hundredths of a point. This further validates the consistent emphasis on sensors and communications systems. Probability of Kill is third, which validates the focus on weapons systems as the third primary factor. The capability to operate for a minimum of 30 days ranks fourth, detection avoidance is fifth, and the two maneuver MOEs, deployment and recovery capability, rank fifth and sixth. Again, the minimal influence on recovery capability is appropriate because it will not adversely affect systems that are non-recoverable or expendable by design, such as Squid.

5.1.6.3 OMOE Determination

With weightings now derived for each of the seven MOEs being evaluated, the performance analysis results are normalized, as shown in Table 5.12.

Table 5.12: Performance Score Normalization

		Capability to Operate for Minimum of 30 Days	Average Data Message Completion Time	Capability for Deployment and Future Platforms	Contemporary and Future Platforms	Probability of Recovery by both Contemporary and Future Platforms	Probability of Detection	Capability to Avoid Detection	Capability of Kill
	Threshold	30	10	1	0	0	0	0	0
	Goal	180	0	3	3	1	1	1	1
Raw Scores	V-CAP	123	4.61	2.5	3.0	0.81	0.59	1.00	
	LD-UUV	126	3.01	1.5	1.5	0.81	0.38	1.00	
	Glider	987	14.13	1.0	2.0	0.75	0.19	0.25	
	Squid	16	3.60	1.0	0.0	0.98	0.08	0.50	
Intermediate Scores	V-CAP	0.620	0.540	0.750	1.000	0.810	0.590	1.000	
	LD-UUV	0.643	0.699	0.250	0.500	0.805	0.380	1.000	
	Glider	6.377	-0.413	0.000	0.667	0.745	0.190	0.250	
	Squid	-0.097	0.640	0.000	0.000	0.984	0.080	0.500	
Scaled Scores	V-CAP	0.620	0.540	0.750	1.000	0.810	0.590	1.000	
	LD-UUV	0.643	0.699	0.250	0.500	0.805	0.380	1.000	
	Glider	1.000	0.000	0.000	0.667	0.745	0.190	0.250	
	Squid	0.000	0.640	0.000	0.000	0.984	0.080	0.500	

The threshold, goal and raw score values for each MOE are listed at the top of Table 5.12. The second section of rows, labeled *Intermediate Scores*, shows adjusted scores that use threshold and goal values as bounds. Some intermediate scores are negative, such as Glider MCT or Squid Endurance, because the system does not meet the threshold value. Intermediate scores are comparative in nature. The third section, labeled *Scaled Scores*, truncates numbers above *one* or below *zero*. This is done to facilitate the production of an OMOE in a consistent range and, more importantly, prevents extraneous reward for a system that greatly exceeds the identified goal. Likewise, no relative benefit is given to systems that “fail better” than other failing systems.

The scaled performance scores, weightings, and resultant OMOE are shown in Table 5.13. Each scaled score is multiplied by the associated weighting and summed to create an

OMOE score. These numbers are appropriately weighted overall performance scores for each concept. Each score is traceable to the original needs analysis and the resultant functional analysis because the weights of the needs and functions are considered in the determination of the analysis MOE weights.

Table 5.13: Overall Measure of Effectiveness

	OMOE							
Weighting	0.162	0.221	0.082	0.022	0.224	0.167	0.122	1.000
V-CAP	0.620	0.540	0.750	1.000	0.810	0.590	1.000	0.705
LD-UUV	0.643	0.699	0.250	0.500	0.805	0.380	1.000	0.656
Glider	1.000	0.000	0.000	0.667	0.745	0.190	0.250	0.406
Squid	0.000	0.640	0.000	0.000	0.984	0.080	0.500	0.436

5.1.7 Sensitivity Analysis

The weights used to determine each concept’s OMOE must be evaluated by sensitivity analysis to ensure that the subjective inputs used to develop those weightings do not adversely affect results. To analyze sensitivity, each MOE weighting is adjusted to a value of 1.00, resulting in all other weights equaling zero. With all emphasis placed on a single variable, a new OMOE is derived. Plotting the regular OMOE along with the new OMOE, a linear equation is developed that represents the relationship between variable weighting and OMOE for each alternative. Plotting the four linear equations gives a visual representation of the effect of variable weighting on each alternative. Points at which intersections occur are indicative of crossover points where an adjustment in weighting would change the rankings of the alternatives for that particular weight. Using this visual representation, one can determine whether minor adjustments would change the preferred alternative.¹¹⁰

110 Systems Engineering Department. Systems Assessment Lecture Notes. Monterey: Naval Postgraduate School, 2010.

5.1.7.1 Endurance Sensitivity

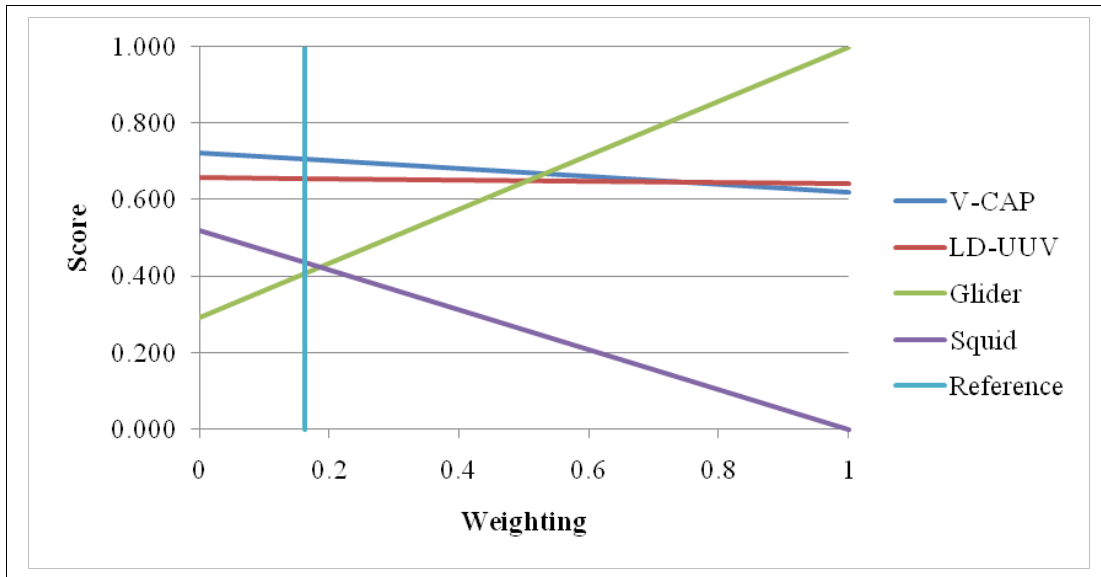

Figure 5.13: Endurance Sensitivity

The vertical line near the origin of Figure 5.13 is representative of the analytical weighting of the MOE, 0.162. At all weightings from 0 to 0.162 the relative rankings of the different alternatives remain the same. V-CAP and LD-UUV remain first and second, respectively until this MOE's weighting reaches a value above 0.5, as Glider's impressive endurance drastically improves its OMOE. Squid's OMOE slope is almost inversely proportional to Glider's due to its low endurance. From Figure 5.13, it is evident that the 30 day endurance MOE is appropriately weighted, as no change in the top two alternatives will occur unless the weighting is more than doubled, which is unrealistic.

5.1.7.2 Communications Sensitivity

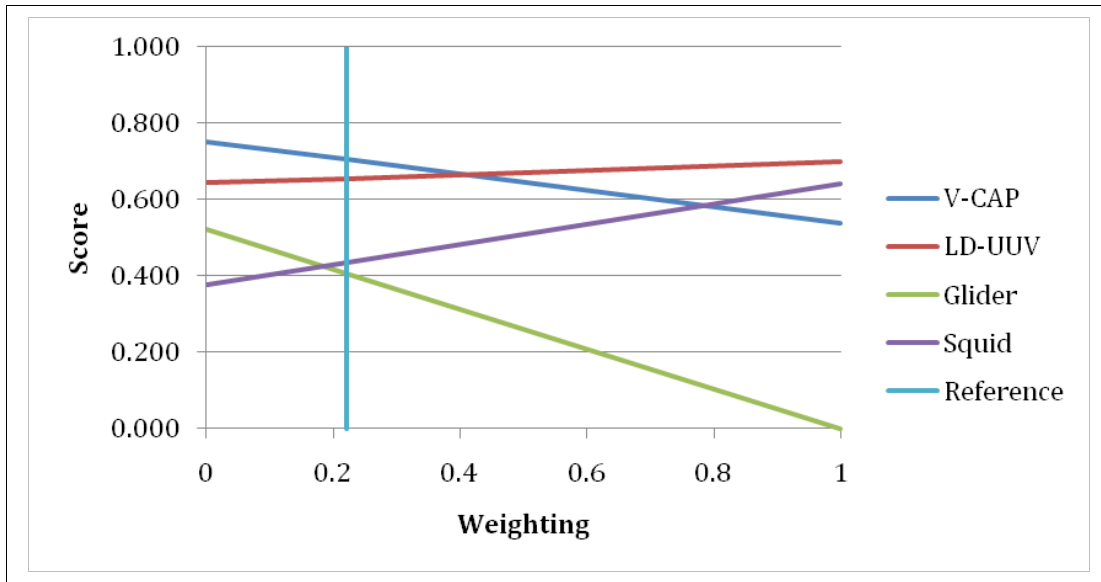

Figure 5.14: Communications Sensitivity

The analytical weighting of the Communications MOE is set at 0.221, represented by the vertical blue line in Figure 5.14. An increase in this MOE's weighting favors LD-UUV and SQUID due to their distributed network configurations. LD-UUV's shorter communications time allows the concept to overtake V-CAP as the number one alternative at a weighting nearly double that of the analytical value. V-CAP suffers from relying completely on acoustic modems for internal communication and Glider suffers due to a very slow time to communicate driven by the slow ascent from depth to surface. From this portion of the sensitivity analysis, it is evident that only a significant increase in weighting would change the respective rankings of the system, which validates the analytical weighting.

5.1.7.3 Deployment Sensitivity

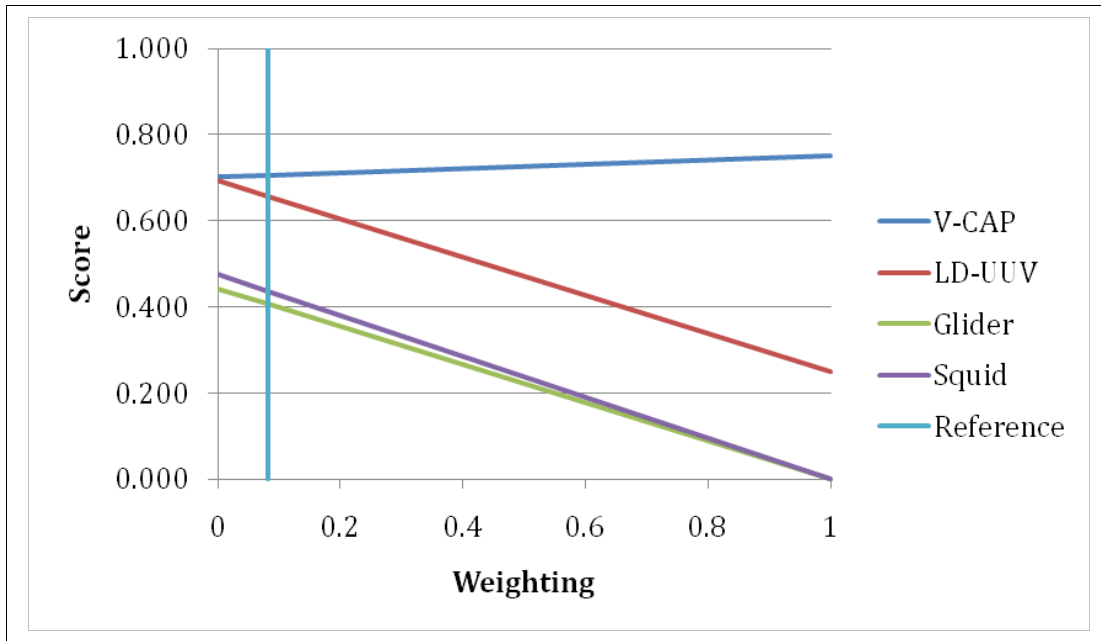

Figure 5.15: Deployment Sensitivity

The analytical weight is set at 0.082 for the deployment MOE. The lack of intersection points in Figure 5.15 indicates that no possible change in the weighting of this variable will have an effect on the final ranking of the four concepts. V-CAP, which can be launched from all three types of platforms, will have continued improvement in MOE value as the weighting increases. The other three alternatives will decrease in value, as none of them are as platform independent as V-CAP for deployment. This diagram indicates that the analytical weighting of the deployment MOE is acceptable.

5.1.7.4 Recovery Sensitivity

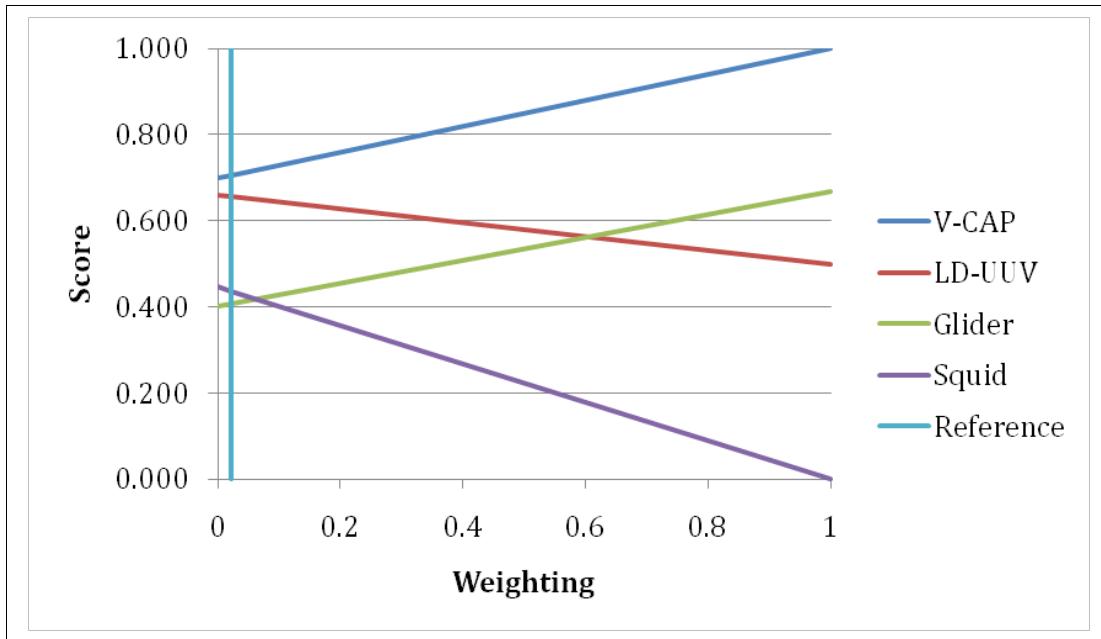

Figure 5.16: Recovery Sensitivity

As shown in Figure 5.16, V-CAP is again the top-ranked alternative regardless of recovery MOE weighting, initially set at 0.022. V-CAP's ability to be recovered by all three types of platforms is reflected in the upward slope of its line, while Squid's inability to be recovered drives its slope steeply downward. An increase in weighting benefits Glider, but the weighting would need to be increased almost thirty times before Glider would rank second, and it would still not score any better relative to V-CAP. For this reason, the analytical value of the recovery MOE weighting is acceptable.

5.1.7.5 Detection Sensitivity

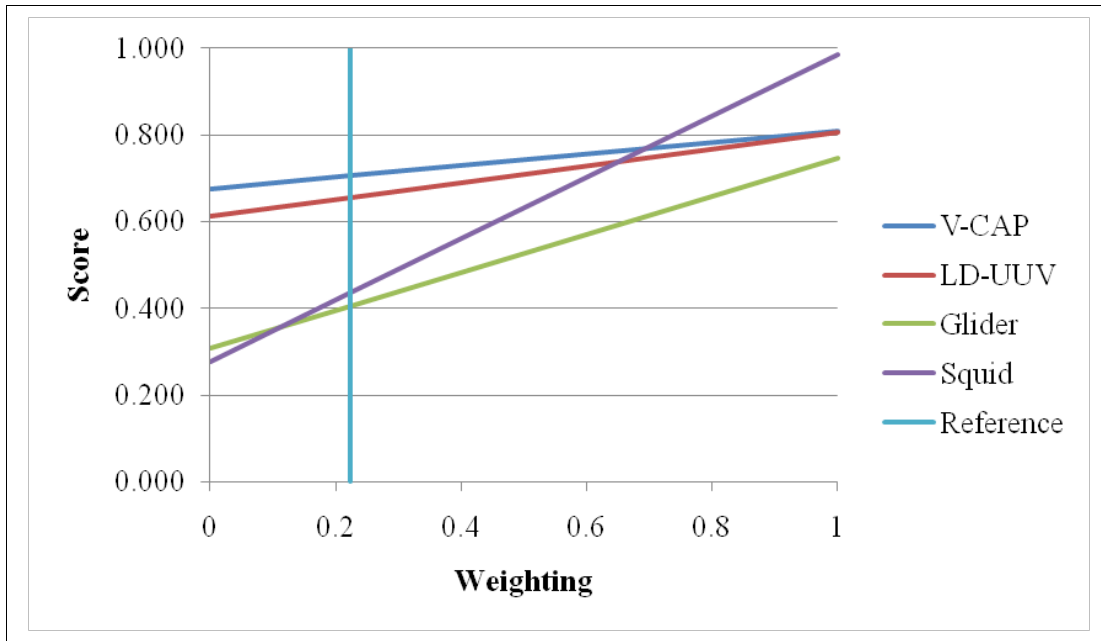

Figure 5.17: Probability of Detection Sensitivity

Set at 0.224, Probability of Detection is one of the top three MOEs by weight for this Analysis of Alternatives. As shown in Figure 5.17, V-CAP and LD-UUV will not change their rankings relative to each other regardless of change in MOE weighting. Squid, with its top marks in Pd (due to its distributed network and heavy overlap of sensor footprint) will become the top-ranked alternative if and only if the MOE weighting is tripled to a value greater than 0.6. This large jump in weighting required for a change in top ranking signifies that the given value of 0.224 is acceptable.

5.1.7.6 Prosecution Sensitivity

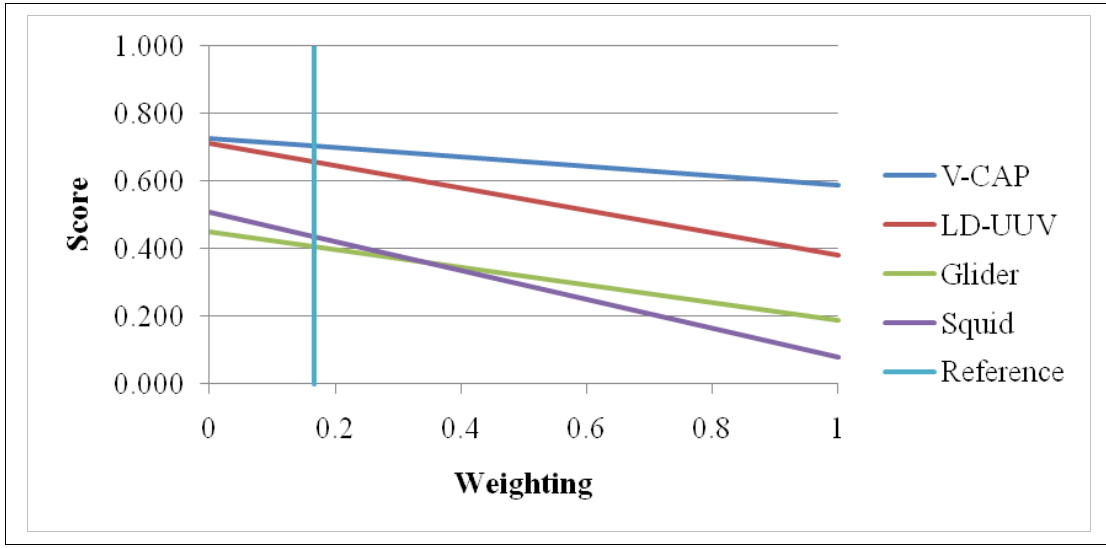

Figure 5.18: Probability of Kill Sensitivity

Probability of Kill is weighted at 0.167, marked by the vertical blue line in Figure 5.18. V-CAP and LD-UUV do not change respective rankings at first and second for any value of Pk weighting. Squid and Glider do change rankings above 0.3, but this is inconsequential. Based on a lack of change in top alternative ranking, the initial value of prosecution MOE weighting is acceptable.

5.1.7.7 Detection Avoidance Sensitivity

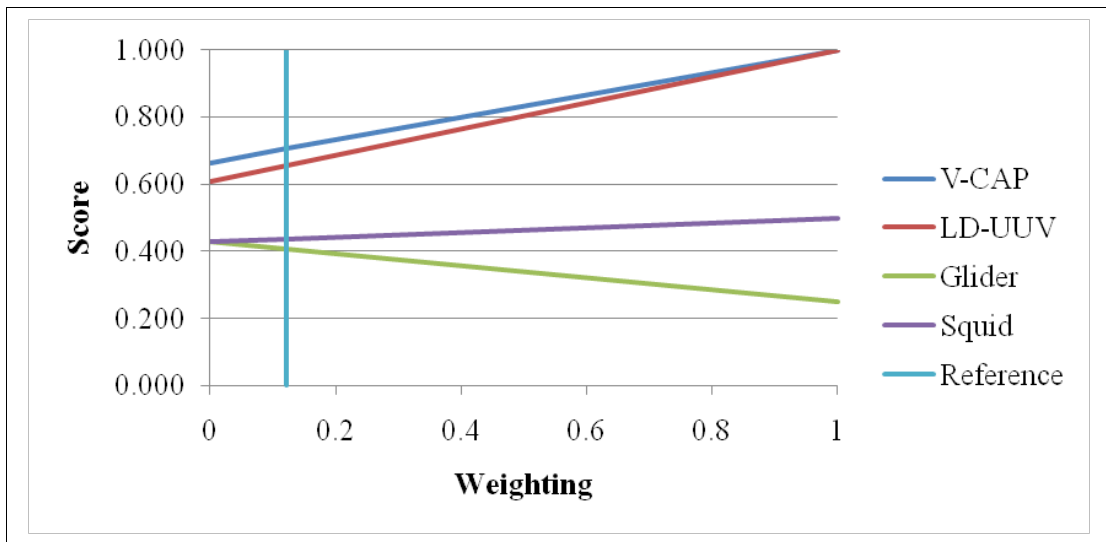

Figure 5.19: Detection Avoidance Sensitivity

Detection avoidance is initially weighted at 0.122. Figure 5.19 shows that V-CAP and LD-UUV both approach a perfect OMOE score as weighting increases, but no change in ranking occurs at any value. Glider, with the lowest detection avoidance score, approaches a rank of zero as weighting increases, but no change in relative position occurs, as shown by a lack of intersections. For this reason, the weighting of the detection avoidance MOE is acceptable.

5.1.7.8 Sensitivity Analysis Results

V-CAP emerged as the top alternative under a reasonable distribution of MOE weightings. The three stochastically determined performance MOEs are perhaps the most critical and the most defensible values, as they are decidedly less subjective than the other MOEs. Focusing attention on Communications, Sensors, and Weapons MOEs still shows a noticeable preference towards V-CAP.

5.1.8 Performance Analysis Summary

The comprehensive scoring of the four concepts is shown in Figure 5.20.

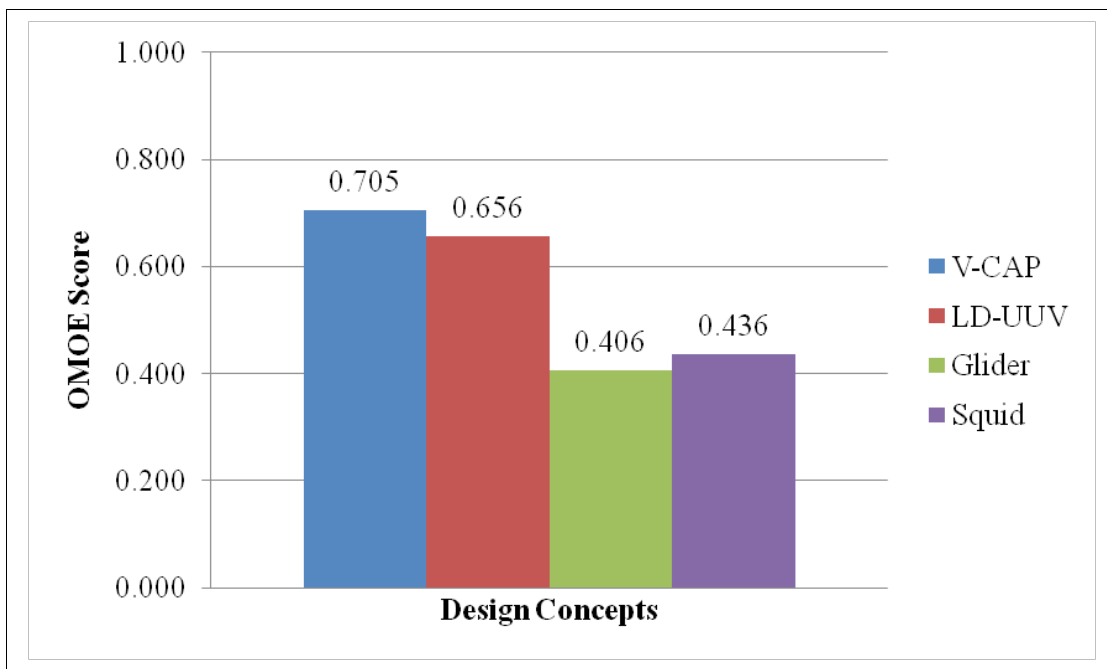

Figure 5.20: Performance Analysis Results Summary (OMOE)

All scores are on a zero to one scale. V-CAP is the highest performing concept with a score of 0.741, or 74.1%. LD-UUV is a close second with a score of 0.678, or 67.8%. Squid is third at 0.485 or 48.5%, and Glider has the lowest utility with a score of 0.376, or 37.6%.

5.1.8.1 V-CAP

Of the three critical MOEs, Probability of Detection, Average Data Message Completion Time, and Probability of Kill, V-CAP only ranks first in Probability of Kill. The concept's slower communications time and lower probability of detection are influenced by its smaller network and reliance on acoustic communications, but the concept's top marks in deployability, recoverability, and detection avoidance coupled with its solid second place performance in endurance and superior prosecution performance give this alternative sufficient utility to rank ahead of the other concepts.

5.1.8.2 LD-UUV

A close second, LD-UUV's primary strength is its rapid ability to communicate, which is achieved by its hardwired paired node system. Average MCT is the only MOE in which LD-UUV dominates the other alternatives, but the heavy weight of the communication MOE gives LD-UUV significant benefit. LD-UUV is comparable to V-CAP in that it is a mobile asset with deployable sensors and precision attack weapons. For this reason, its overall scores in other categories are very similar to V-CAP. Due primarily to its larger size the LD-UUV concept falls behind V-CAP, which reduces endurance capability as well as the number of assets that can deploy and retrieve the unit. LD-UUV's final OMOE is lower than that of V-CAP, but this concept should not be discounted since it may have multiple utility in mission profiles other than the one modeled for this comparison.

5.1.8.3 Squid

Squid ranks third in performance among the four alternatives. The system's distributed network gives it a large sensor footprint with sufficient overlap to provide a high probability of detection and a rapid MCT, which account for the majority of Squid's utility. The low-yield, unguided, floating munitions employed by the system are not conducive to a high probability of kill, strongly reducing its overall performance score. The system's lack of maneuverability or

recoverability also has negative effects on its OMOE; however, these effects are minor when compared to its inability to effectively prosecute threats.

5.1.8.4 Glider

Glider's performance is lowest overall with an OMOE of less than half of the top alternative. While Glider sports the highest endurance of any alternative, it pays the price in speed and maneuverability. Those shortfalls hinder the speed at which Glider can transmit a message, reduce the likelihood of a successful engagement with a target (reducing Probability of Kill), and reduce the Probability of Avoiding Detection. Further reducing Glider's utility is the reduction in the number of available weapons and sensing assets as engagements occur, since the number of Gliders on station decreases by one each time an attack is mounted.

5.2. Cost Analysis

The complexities involved in estimating the cost of conceptual systems, such as candidate AUWS concepts, do not favor a detailed accurate analysis of Life Cycle Cost. The results of this cost analysis will not provide a detailed LCC estimate of each AUWS concept accurate to within plus or minus a certain percentage; rather, a means of comparative analysis based on a similar functional framework is generated. In order to provide a comprehensive LCC estimate, additional, detailed examination of each individual concept would be necessary. Only the most pertinent portions of an LCCE are calculated in this analysis in order to provide a foundation for top level comparison. Figure 5.21 shows the generalized form of an LCCE. The sum of each section provides the total cost of a system over its useful life.

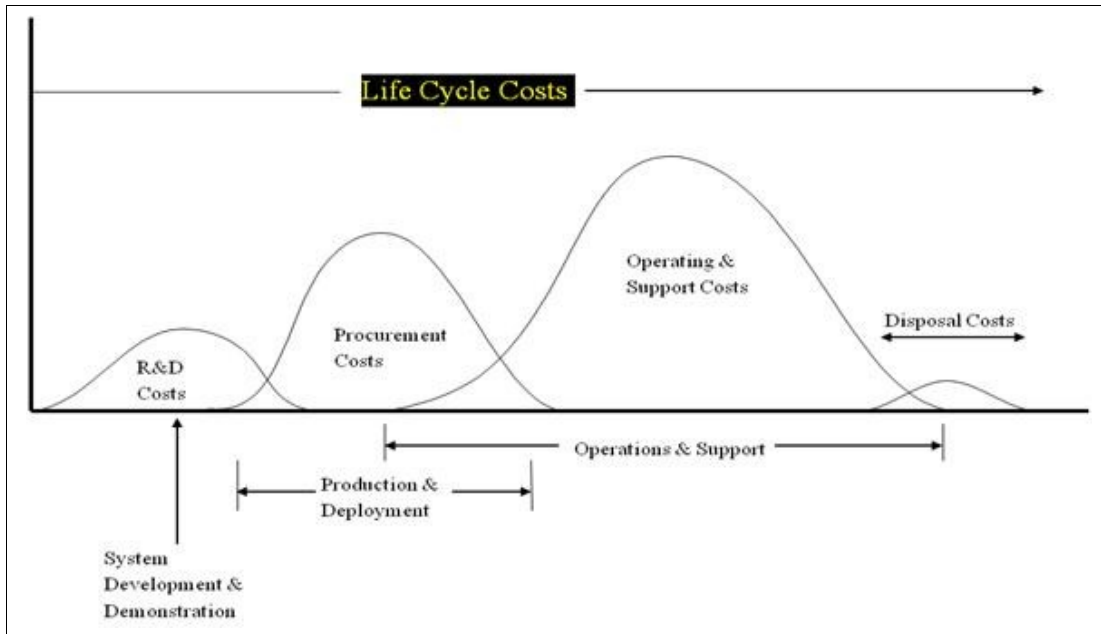

Figure 5.21: Life Cycle Cost Estimate¹¹¹

5.2.1 Research and Development Cost

Research and Development (R&D) costs are not included in the estimate for comparison. The least mature technology for all AUWS concepts is the decision engine. According to RAND Corporation, a 2008 survey of undersea vehicle developers indicates that autonomy is the single greatest long-term challenge in developing systems like AUWS.¹¹² IBM's state of the art supercomputer Watson (detailed in Appendix G) is able to audibly gather information and generate solutions to a problem with varying confidence levels. Each AUWS system will require a similar capability to autonomously identify and engage a target without producing a type I error (identifying a friendly or unknown contact as a threat and engaging it). Research and development of a super-compact Watson-like computer is needed. The costs incurred in the development of a miniaturized computer with such high processing capabilities is presumed to capture the bulk of R&D costs no matter the AUWS platform shape or size variant selected; required R&D expenditures apply equally to all concepts and are not calculated.

¹¹¹ Nussbaum, Daniel. *Definitions and Terminology*. Monterey: Naval Postgraduate School, 2011.

¹¹² Button, Robert W, et al. *A Survey of Missions for Unmanned Undersea Vehicles*. Santa Monica: RAND Corporation, 2009. 16.

5.2.2 Procurement Cost

Procurement costs, or acquisition costs, will have a significant effect on a life cycle cost estimate. The amount of materiel to procure, the interval of procurement, and the possibility of future upgrades are only a few of the issues that affect procurement cost. Further analysis of the specific Science and Technology Gap related to AUWS is required for these issues to be clarified. Simple comparative estimations for procurement costs, detailed for each concept variant below, were developed and incorporated in the AUWS LCCE.

5.2.3 Operations and Support Cost

Operation and Support costs (O&S) have the greatest variation between concepts and are the costs used in the comparison of concepts. Each concept makes use of different quantities of acoustic sensors, warheads, energy (be it in the form of battery power, fuel cell, or Otto fuel II), and some type of fuselage. It is by way of analogy to current DoD materiel paired with the modeling and simulation scenario that an O&S estimate for each concept is generated.

An important component of O&S cost that is not addressed in this analysis is personnel cost. The unmanned nature of the AUWS concepts does not alleviate the need for personnel to train on, maintain, and operate the systems. In a larger arena, there is significant debate as to whether unmanned systems reduce personnel costs at all. This analysis assumes personnel costs will not differ greatly among the four concepts, and a detailed breakdown of such costs is left for further analysis.

In the modeling and simulation scenario, each concept operates in a 10 NM by 3 NM area with a depth of 300 feet. The simulations reveal the number of components necessary to cover the entire volume of water for each concept. They also reveal the average number of engagements conducted in the simulated time frame. These results aid the formation of an operational requirements construct for various periods of time. Each AUWS concept will operate 24 hours a day for 30 days. It is assumed that AUWS will be employed six months out of every year. All concepts face the same deployment over one month, one year, ten years, and twenty years for the O&S estimate. On average, AUWS will be cleared to engage threats one day per 30 day period. In other words, the results of one simulation run are used to determine weapons expended over the entire 30 day period.

This cost analysis assumes a constant deployment schedule, constant threats, and no required upgrades to the systems. Within this simplified analytical construct, the four potential AUWS concepts can be effectively compared.

5.2.3.1 Common Equipment and General Assumptions

- All dollar values are given in fiscal year 2011 dollars.
- The cost of the employed acoustic sensor will be the same across all concepts and is analogous to the cost of a DICASS buoy (SSQ-62). The DICASS buoy has a maximum operation time of eight hours. From the Military Cost Handbook, each DICASS buoy costs the Navy \$1,100.¹¹³ This returns a cost of \$138 per hour of operation. With 720 hours in a 30 day period, the cost of one sensor amounts to \$99,000. This cost encompasses the hardware, software, and sensor energy used for the 30 day period. Since the DICASS buoy estimate also includes its ability to communicate, communication system costs are folded into the sensor cost estimate.
- Otto fuel II cost is derived from the cost and unclassified capabilities of a Mk-46 torpedo. From Appendix F, the energy stored in a Mk-46 torpedo is estimated at 40.5 MJ. The Military Cost Handbook prices the torpedo at \$280,100.¹¹⁴ The dollar cost of each MJ provided by Otto fuel II is \$6,916.
- The automotive industry provides the current cost of lithium ion battery power. AUWS energy cost estimates associated with lithium batteries make use of Nissan Motor Company's cost estimate of \$375 per kilowatt hour (\$104.2 per MJ).¹¹⁵ This estimate is not reflective of the expected cost decrease over the life of AUWS.
- Explosive material cost is analogous to the Mk-54 torpedo. The Mk-54 carries 97 pounds (44 kg) of explosive material. Each torpedo costs \$535,200.¹¹⁶ The cost per pound of explosive is \$5,518, or \$12,165 per kilogram.

113 Nicholas, Ted and Rossi, Rita. "SONAR/Sonobuoy Costs." Military Cost Handbook. 13th ed. Fountain Valley: Data Search Associates. 2009. 3-4.

114 Nicholas, Ted and Rossi, Rita. "Torpedo/Mine Costs." Military Cost Handbook. 12th ed. Fountain Valley: Data Search Associates. 1991. 9-4, 9-5.

115 Electric Vehicle News. "Nissan say Leaf EV Battery Pack Cost Only \$375 per kWh." 6 May 2010. *electric-vehicles-cars-bikes.blogspot.com*. 13 May 2011 <<http://electric-vehicles-cars-bikes.blogspot.com/2010/05/nissan-say-leaf-ev-battery-pack-cost.html>>.

116 Nicholas, Ted and Rossi, Rita. "Torpedo/Mine Costs." Military Cost Handbook. 13th ed. Fountain Valley: Data Search Associates. 2009. 5-4, 5-5.

5.2.3.2 LD-UUV Cost Estimate

This concept employs a single LD-UUV that traverses into the operational area, delivers networked acoustic sensors, then lies in wait to deploy ordnance as necessary. At the conclusion of the 30 day mission, the vehicle transits out of the area of interest for collection by the controlling agency. The LD-UUV is assumed to have a lifespan of five years while supporting the simulated operational demand. It is also assumed that no intermediate or depot level maintenance is considered and no LD-UUV body is lost during the five year lifespan. The cost associated with the LD-UUV body is detailed as follows:

- The cost of the LD-UUV body is analogous to the cost of the Advanced SEAL Delivery System (ASDS) in terms of dollars per cubic foot. The United States Government Accounting Office (GAO) prices each ASDS at about \$351 million.¹¹⁷ The 65 foot long by 8 foot diameter vehicle has a cost of about \$108,000 per cubic foot. The LD-UUV body is envisioned to be 20 feet long and 80 inches in diameter giving a total volume of about 700 cubic feet. The cost of one LD-UUV body is about \$75 million.
 - **Ten Year Estimate (body):** \$150,197,000
 - **Twenty Year Estimate (body):** \$300,392,000
- The LD-UUV delivers 16 non-recoverable acoustic sensor nodes throughout the area of interest for every 30 day mission.
 - **Ten Year Estimate (sensors):** \$95,040,000
 - **Twenty Year Estimate (sensors):** \$190,080,000
- LD-UUV fires an average of three lightweight torpedoes in one 30 day mission. The lightweight torpedo is analogous to the Mk-54 torpedo. Each Mk-54 costs \$535,200.
 - **Ten Year Estimate (weapons):** \$96,336,000
 - **Twenty Year Estimate (weapons):** \$192,672,000
- Lithium ion batteries power LD-UUV. It is estimated from Endurance Analysis that 532 MJ are required for a 30 day mission.
 - **Ten Year Estimate (energy):** \$3,326,000

¹¹⁷ Government Accounting Office. "Defense Acquisitions: Assessment of Selected Major Weapon Programs." Washington: GPO, 2005. 27.

- **Twenty Year Estimate (energy):** \$6,652,000
- For the selected cost metrics (body, sensor, weapons, and propulsion energy) the total ten and twenty year operational cost estimates for LD-UUV are:
 - **Ten Year Estimate:** \$345 million
 - **Twenty Year Estimate:** \$690 million

5.2.3.3 V-CAP Cost Estimate

The V-CAP concept makes use of five vehicles (one Hunter Unit and four Killer Units) to meet the operational demand of the model scenario. To simplify the estimate, both V-CAP body types will have a lifespan of five years while supporting the simulated operational demand. No intermediate or depot level maintenance is considered and it is assumed that no V-CAP body is lost during the five year lifespan. The cost associated with the V-CAP bodies is detailed as follows:

- The cost to replace expired V-CAP bodies is assumed to be analogous to various Mk-48 torpedo variants. The complexity of the Hunter Unit drives it to be analogous to the cost per kilogram of the Mk-48 Common Broadband Advanced Sonar System (CBASS). Each CBASS carries a cost of \$3.8 million and has a mass of about 1670 kilograms (\$2,275 per kilogram),¹¹⁸ which is equivalent to the projected mass of the Hunter Unit.
 - **Ten Year Estimate (Hunter Unit body):** \$7,600,000
 - **Twenty Year Estimate (Hunter Unit body):** \$15,200,000
- The Killer Unit cost is analogous to the cost per kilogram of the original Mk-48. Each original Mk-48 carries a cost of \$2.97 million and has a mass of about 1550 kilograms (\$1,916 per kilogram).¹¹⁹ The mass of the killer is assumed to be the mass of the original Mk-48 less the mass of the explosive (1550-290=1260 kg).
 - **Ten Year Estimate (Killer Unit body):** \$19,315,000
 - **Twenty Year Estimate (Killer Unit body):** \$38,629,000

118 "Mk-48 CBASS." *Deagle.com*. 25 Mar. 2011.

<http://www.deagle.com/Torpedoes/Mark-48-CBASS_a001143002.aspx>.

119 Polmar, Norman. "The Ships and Aircraft of the U.S. Fleet: Torpedoes." United States Naval Institute Proceedings, Nov.1978. 159.

- V-CAP Hunter Unit deploys eight non-recoverable acoustic sensors for every 30 day mission.
 - **Ten Year Estimate (sensors):** \$47,520,000
 - **Twenty Year Estimate (sensors):** \$95,040,000
- V-CAP Killer Unit fires an average of 4.8 mini torpedoes in a 30 day operational period. The V-CAP torpedo is considered analogous to the Compact Rapid Attack Weapon (CRAW); however, the CRAW is still in a developmental phase and therefore lacks reliable unit cost data. The costs of the CRAW and V-CAP mini torpedoes are analogous to the Mk-54 torpedo by the previously calculated ratio of cost per unit of explosive. Each V-CAP mini torpedo carries 20 kilograms of explosive and is thus \$243,270 per unit.
 - **Ten Year Estimate (weapons):** \$70,063,000
 - **Twenty Year Estimate (weapons):** \$140,125,000
- From Endurance Analysis, it is estimated that each Hunter Unit will require 33 MJ of energy for a 30 day operational period. It is assumed that Killer Units will require an equivalent amount of energy. Five total bodies are required for the same time period. V-CAP stores half of its energy in the form of Otto fuel II, and the other half in lithium ion batteries.
 - **Ten Year Estimate (energy):** \$34,750,000
 - **Twenty Year Estimate (energy):** \$69,450,000
- For the selected cost metrics the total ten and twenty year operational cost estimates for V-CAP are:
 - **Ten Year Estimate:** \$179 million
 - **Twenty Year Estimate:** \$359 million

5.2.3.4 Glider Cost Estimate

The Glider concept makes use of 17 vehicles to meet the operational demand of the model scenario. Glider bodies are assumed to have a lifespan of three years while supporting the simulated operational demand. No intermediate or depot level maintenance is considered and it is assumed that no Glider body is lost (outside of the performance of its mission) during the five

year lifespan. The cost structure of the Glider concept is slightly different due to the fact that each Glider vehicle is the body, sensor, and warhead. Only Gliders that have not engaged a target are recovered following a 30 day operation. An average of 1.5 Gliders engages a target in every 30 day operation. New Gliders replenish the pack to ensure every operation begins with 17 Gliders. A Discrete Time Markov Chain model is used to estimate the number of the original 17 Gliders that survive three years of deployment. From this model it is determined that, on average, 3.2 units reach the end of their three year operational lifespan and require replacement. Beyond the three year deployment, Gliders may or may not require replacement following each operational month due to the age and survival of replenished units. Analysis is simplified by assuming a total of 3.2 units are replaced every three years.

Glider body cost is analogous the cost of Teledyne Webb's Slocum Glider. Rand Corporation reports the unit cost of Slocum Glider as \$50,000 in 2002 dollars,¹²⁰ which equates to \$60,000 in 2011 dollars using the Navy Weapons Procurement (WPN) inflation index.¹²¹ The Slocum Glider is very compact having a body length of only 1.5 meters and a mass of 52 kilograms.¹²² The volume of the AUWS Glider is slightly larger – to accommodate armament, terminal propulsion, sensors, communications, and energy stores – while the mass of the AUWS Glider is roughly doubled, hence a doubling in cost is appropriate. A single Glider body costs \$120,000.

Each Glider is equipped with one acoustic sensor, a ten kilogram warhead, a magnesium air fuel cell, and Otto fuel II for terminal propulsion. The associated cost of the sensor and the warhead are derived in the same manner as previous systems.

The cost of magnesium air fuel cells is estimated at \$185 per MJ, based on current market data.¹²³ Since Gliders only require a capacity of 1.3 MJ from their fuel cells for a 30 day mission, the unit cost is estimated at \$240. For target intercept, assuming that the terminal maneuver of Glider is 20 knots for 15 seconds, energy required to overcome drag is 0.12 MJ. This energy value is derived from V-CAP range calculations found in Appendix F (Glider and V-CAP have equivalent

120 Button, Robert W, et al. A Survey of Missions for Unmanned Undersea Vehicles. Santa Monica: RAND Corporation, 2009. 156.

121 Naval Center for Cost Analysis. "JIC_Inflation_Calc_FY11_Ver1a.xls." 2011. *ncca.navy.mil*. 13 May 2011 <www.ncca.navy.mil/tools/JIC_Inflation_Calc_FY11_Ver1a.xls>.

122 Button 156.

123 Alibaba.com. Magnesium air fuel cell. 2011. 13 May 2011 <http://www.alibaba.com/product-free/101662196/Magnesium_air_fuel_cell.html>.

drag coefficients). Each Glider is loaded with enough Otto fuel II, estimated at \$6,916 per MJ, to complete one terminal prosecution. The total cost of energy, combining the fuel cell and Otto fuel II, is \$1000 per unit.

The estimated cost of a Glider unit, \$342,000, is the sum of the costs associated with the body, sensor, warhead, and energy.

- Given the unit cost and the expected attrition rate, the total ten and twenty year operational cost estimates for the Glider concept are:
 - **Ten Year Estimate:** \$40 million
 - **Twenty Year Estimate:** \$75 million

5.2.3.5 Squid

The Squid concept employs immobile networked sensor nodes each armed with six explosive charges. 130 nodes are required to cover the simulated operational area. All deployed nodes are non-recoverable. Nodes are deployed to an area of interest via artillery deployment or air drop. Artillery munitions provide the means for a cost analogy to a Squid node.

Each Squid node, for costing purposes, is analogous to the Navy's Extended Range Guided Munition (ERGM). GAO prices each ERGM round at roughly \$56,000.¹²⁴ At the given cost, the ERGM comes equipped with a propelling charge, munition (or submunitions depending on configuration), and navigation capabilities.¹²⁵ The complexity of the ERGM is roughly equivalent to the complexity of Squid Weapons and Comms Nodes, with the exception of acoustic sensors. The unit cost of a Squid node is estimated at \$155,000, accounting for the cost of an acoustic sensor in addition to the baseline ERGM cost. Each deployment of 130 Squid nodes will cost approximately \$20 million.

- The ten and twenty year cost estimates for Squid are:
 - **Ten Year Estimate:** \$1,209 million
 - **Twenty Year Estimate:** \$2,418 million

5.2.4 Disposal Cost

Disposal costs are not calculated for this cost estimate.

124 Government Accounting Office. Defense Acquisitions: Challenges Remain in Developing Capabilities for Naval Surface Fire Support. Washington: GPO, 2006. 11.

125 GAO 11.

5.2.5 Cost Analysis Summary

Overall twenty year cost estimates for each of the AUWS concepts are summarized in Table 5.14. Purely from an operational cost perspective, Glider is the most affordable alternative; however, cost is not the only factor involved in concept down selection. Various parameters are considered in the overall comparison to provide stakeholders with a system that meets their desires. For example, based on P_k , Glider may not be the best selection. The low cost of the system is thwarted by simulation results showing that very few Gliders actually succeed in engaging their targets. If the desire is to produce a glider-like system, then technological advances must be made to improve P_k or significantly more Gliders must be introduced to the operational area. Either case may significantly drive overall system costs up. Squid, on the other hand, is not a cost effective system given its high cost. If a specific need arises to develop a non-recoverable, highly distributed system, the unit cost of Squid must first be driven down to an acceptable level to make the production decision fiscally sound.

Table 5.14: Summary of Twenty Year Cost Estimates (FY11 \$M)

	V-CAP	LD-UUV	Glider	Squid
Body	53.83	300.39	75	2,418
Sensors	95.04	190.08	--	--
Weapons	140.13	192.67	--	--
Energy	69.45	6.65	--	--
Total	359	690	75	2,418

5.3 Risk Analysis

A holistic approach is taken to assess the risk of each of the AUWS concepts. In the context of this analysis, risk is associated with the uncertainty of an unwanted event occurring. By exploring the technical, schedule, and cost aspects of the system in terms of its fundamental, hierarchical, and organizational structure; risk is comprehensively analyzed. Utilizing the Oak Ridge Study of “good” risk analysis, the following seven criteria are applied to validate the process:

- Comprehensive
- Logically sound
- Practical (implementable)

- Open to evaluation
- Politically acceptable
- Compatible with institutions
- Conducive to learning¹²⁶

The trade-off between risks, benefits, and costs for the seven criteria – C3, ISR, Armament, Maneuver, OPSEC, Power, and Structure – of the four AUWS concepts are identified, quantified, and evaluated. By maintaining focus on technical, schedule, and cost risks, the likelihood and consequence of the critical areas are evaluated. Technical risk is determined by the possibility a requirement will not be achieved based on the combination of individual sub-criteria within a risk factor criteria. Any factors influencing the technological development are considered, including budgeting and integration issues. Cost risks are based on the possibility that a system's allocated budget would be exceeded. This includes cost over-runs and budgetary constraints factored over the system life cycle. Schedule risk is based on the possibility of the system failing to meet planned milestones. Schedule risks are often influenced by estimation errors originating in other areas. Taking all of these factors into consideration, risk is calculated as the probability of a risk event occurring (likelihood) multiplied by the severity of impact of that event (consequence).¹²⁷

The individual criteria level of risk is determined using a combination of empirical data and technical expertise. A more detailed breakdown of the empirical data used can be found in Appendix H. The likelihood and consequence of a risk event are rated using impact levels on a scale of one to five. The impact levels are determined based on the actual range of probability or severity assessed for each AUWS criteria. The relationship between the impact level, range, and weighting is shown in Table 5.15.

126 Fischhoff, B., et al., Approaches to Acceptable Risk: A Critical Guide. Eugene: Oak Ridge National Laboratory Sub-7656, 1980. 98.

127 Smith, Preston G. and Guy M. Merritt, Proactive Risk Management. New York: Productivity Press, 2002. 72.

Table 5.15: Weighting Legend

Impact Level	Actual Probability/ Severity Range (%)	Weighting
1	0 <= 20.5	0.1
2	20.5 <= 40.5	0.3
3	40.5 <= 60.5	0.5
4	60.5 <= 80.5	0.7
5	80.5 <= 100	0.9

An impact level one indicates a minimal impact by the assessed AUWS criteria. At the other end of the scale, an impact level five indicates a catastrophic impact to AUWS by the assessed criteria. Both consequence and likelihood impact levels are calculated for each AUWS criteria. These impact levels are then used to determine individual criteria Risk Factors for each AUWS concept.

5.3.1. Risk Factors

While there are several methodologies for assessing risk, risk is addressed here in terms of two major variables. These variables are then used to determine the overall total combined Risk Factor for the four AUWS concepts. The following mathematical expression, utilizing the individual criteria's level of risk, is used:

$$Risk\ Factor\ (RF) = P_f + C_f - (P_f)(C_f)$$

where P_f is the probability of failure and C_f is the consequence of failure.^{128 129} In order to determine the total risk for each of the AUWS concepts, the overall P_f and C_f are determined. The overall system P_f is determined by averaging the associated technical, schedule, and cost probabilities. The technical P_f averages the P_f for the seven criteria (determined from the associated weighting of the impact level) within each concept. In order to determine the overall C_f , the sum of the technical, schedule, and cost risks are determined relative to the consequence of their weighting:

$$C_f = C_{f(technical)} * Consequence\ Weight_{technical} + C_{f(schedule)} * Consequence\ Weight_{schedule} + C_{f(cost)} * Consequence\ Weight_{cost}$$

128 Blanchard, Benjamin S., *Systems Engineering Management*, 3rd ed. Hoboken: John Wiley & Sons, Inc, 2004. 328.

129 This model is adapted from the procedure included in the 1986 edition of the *Systems Engineering Management Guide*, published by the Defense Systems Management College, Fort Belvoir, VA. Although there are other models in use today, for the purpose of this analysis, this methodology is utilized and tailored for AUWS.

The technical C_f for each system is determined in a similar fashion by summing each criteria's C_f relative to the actual weight of the criteria:

$$C_f = C_{f(power)} * Criteria\ Weight_{power} + \dots + C_{f(structure)} * Criteria\ Weight_{structure}$$

Table 5.16 shows the assessed overall P_f and C_f , and subsequent Risk Factor, for each AUWS concept.

Table 5.16: Total Risk Factor Results by System

AUWS Concept	P_f	C_f	Risk Factor
V-CAP	0.34	0.32	0.55
LD-UUV	0.26	0.40	0.55
Glider	0.28	0.34	0.52
Squid	0.20	0.32	0.45

From the overall Risk Factors, a graphical representation of the relationship between likelihood and consequence, shown in Figure 5.22, is plotted for each of the four AUWS concepts. This analysis takes into account the individual criteria weighting as well as the weighting associated with the three categories, technical, schedule, and cost. The V-CAP and LD-UUV concepts exhibit the highest overall risk factors; this is due in large part to the level of immature technology which is further explained in the risk matrices analysis. Glider's overall risk is slightly lower due to its reliance on more mature technology. Squid has the lowest risk factor, which is due primarily to the relative simplicity of its fundamental design.

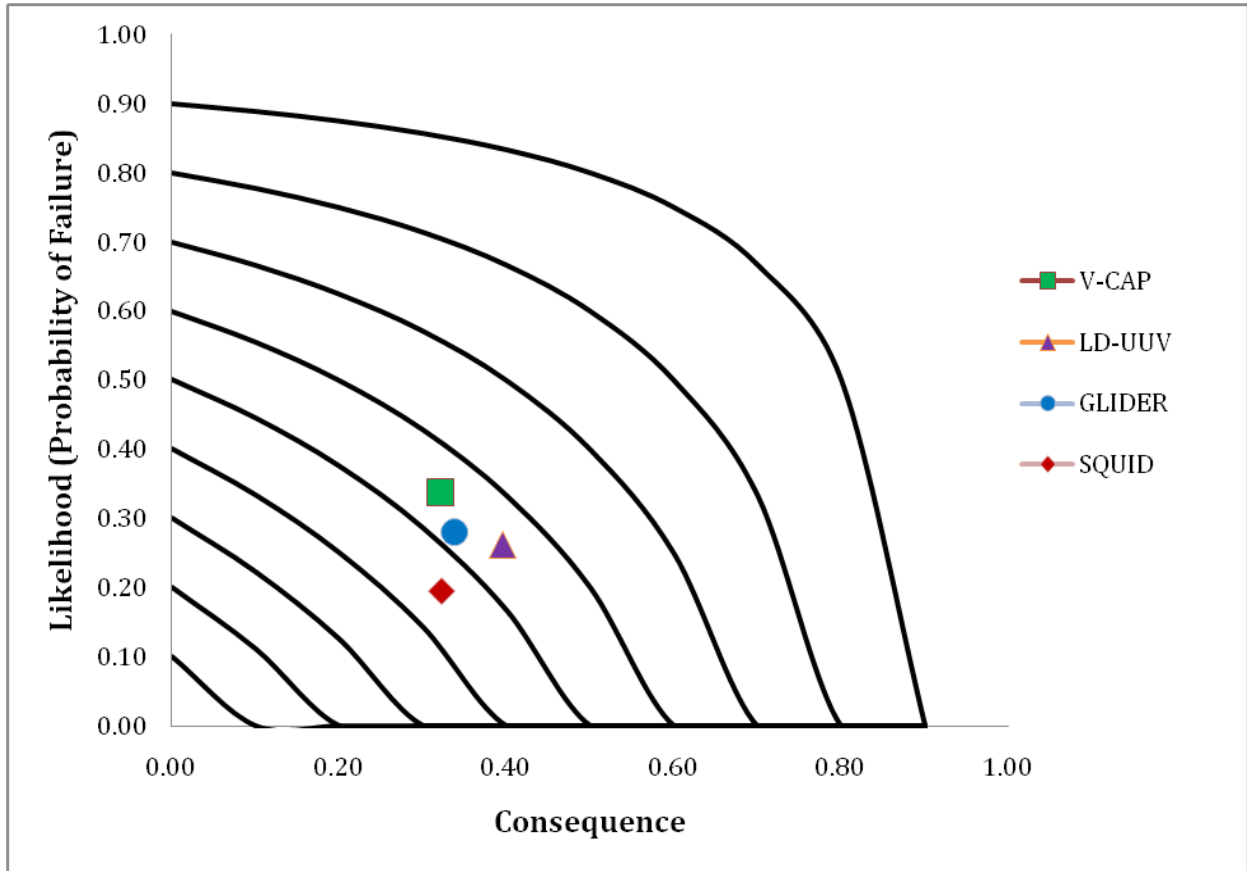

Figure 5.22: Overall Risk Factor Analysis for AUWS Concepts

5.3.2. Risk Management

With the risk factors of each criterion in the four AUWS concepts determined, each value is then applied to a risk analysis and reporting flow chart to determine the best course of action for risk management should the system be developed beyond the conceptual phase. Figure 5.23 is the flow chart used for risk analysis. It delineates what mitigation actions or management procedures may be required based on the criteria overall risk factor. All of the AUWS concepts are assessed as Medium Risk overall. Risk Matrices help to highlight some of the individual criteria risks that may need to be mitigated.

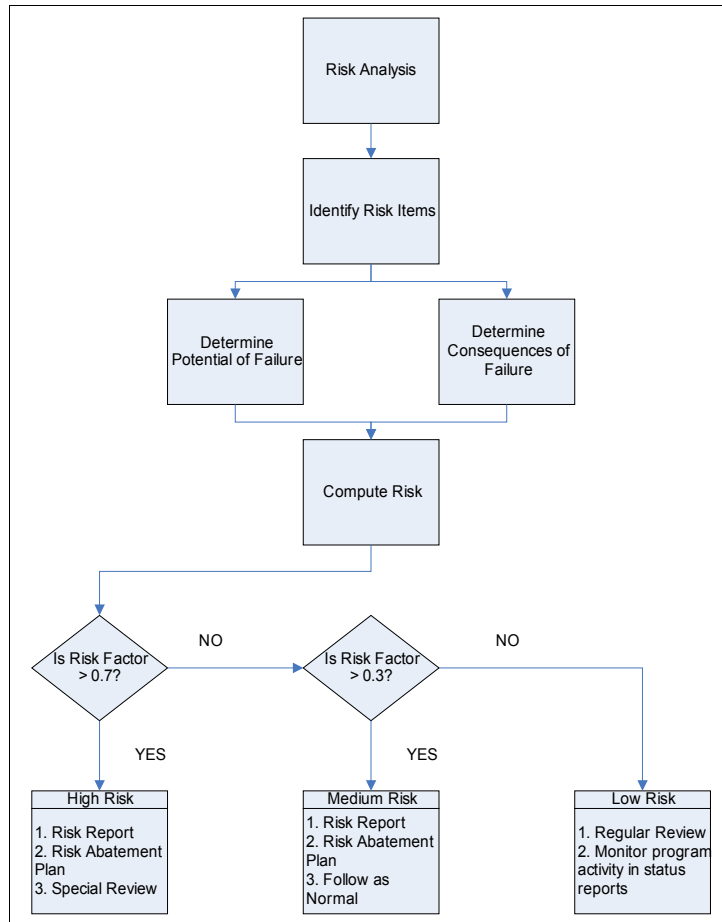

Figure 5.23: Risk Analysis Logical Flow Chart¹³⁰

In addition to the risk flow chart, risk matrices are used to graphically represent the analysis of each criterion's risk. Risk matrices are a pictorial representation of risk that qualitatively displays the risk priority in terms of likelihood and consequence. They provide decision makers with a means of prioritizing risk procedures. The matrices utilize green, yellow, and red sections to denote low, medium, and high risk respectively. As described in the flow chart above, low risks generally cause minimal impact, thus requiring minimal oversight. Medium risks may cause some problems to an overall program and require a mitigation plan to prevent a program disruption. High risks are those which have the potential to result in major disruptions to a program if left unaddressed. These risks require immediate and persistent action and review. A complete listing of risk matrices for all AUWS risk analysis can be found in

130 Blanchard 331.

Appendix I. The overall risk assessments for each of the four AUWS concepts' individual factors are as follows.

5.3.3 V-CAP Risk Assessment

Table 5.17 illustrates that the areas requiring the most immediate attention for the V-CAP system are Cost, ISR, and Power. In order to mitigate some of the risk associated with ISR and Power, more resources should be allocated to the Research and Development phase. Since this system relies heavily on emerging technology the likelihood of cost over-runs is significant. This may be reduced through vigilant management of the project life cycle cost assessments.

Table 5.17: V-CAP Risk Factors

V-CAP Risk						
Likelihood	5					
	4					
	3		Cost	ISR		
	2	Schedule	OPSEC		Power	
	1	Structure	Armament Maneuver	C3		
		1	2	3	4	5
		Consequence				

5.3.4 LD-UUV Risk Assessment

Similar to V-CAP, LD-UUV is faced with Cost, ISR, and Power as its areas most likely to incur difficulty, as depicted in Table 5.18. It follows logically that the same risk mitigation and management techniques utilized for V-CAP should be utilized for LD-UUV. A heavy reliance on emerging technology causes a significant risk cost over-runs.

Table 5.18: LD-UUV Risk Factors

LD-UUV Risk						
Likelihood	5					
	4					
	3					
	2	Schedule OPSEC		ISR Cost	Power	
	1		Armament Structure	C3 Maneuver		
		1	2	3	4	5
		Consequence				

5.3.5 Glider Risk Assessment

Table 5.19 points out the most critical areas for the Glider concept are ISR and Maneuver. In order to mitigate some of the risk associated with ISR and Maneuver more resources should be allocated to the R&D phase. Of particular concern with Glider is the need for a significant increase in maximum speed. It is assessed that a minimum of two knots is necessary for Glider to be tactically useful and cost-effective. Given that power increases as the cube of velocity and that current gliders can maintain only an average speed of 0.5 knots headway, a 64-fold increase in power drawn from the environment will be required. Currents and other environmental factors only further increase the technological challenge to Glider.

Table 5.19: Glider Risk Factors

Glider Risk						
Likelihood	5					
	4					
	3			ISR		
	2		C3 Structure Schedule Cost		Maneuver	
	1		Power Armament OPSEC			
		1	2	3	4	5
		Consequence				

5.3.6 Squid Risk Assessment

Table 5.20 indicates that Squid’s most critical areas are ISR, C3, and Power. Once again, in order to mitigate some of the risk associated with ISR, C3, and Power, more resources should be allocated to the R&D phase. Since this system is relatively simple in its design, cost and schedule over-runs are not as likely to occur; thus significantly reducing the overall system risk factor when compared to the V-CAP, LD-UUV, or Glider concepts.

Table 5.20: Squid Risk Factors

Squid Risk						
Likelihood	5					
	4		ISR			
	3	Maneuver		C3		
	2		Armament OPSEC	Power		
	1		Structure Schedule Cost			
		1	2	3	4	5
		Consequence				

5.3.7 Risk Analysis Summary

Figure 5.24 graphically depicts the relative risk for each criterion within the four AUWS concepts. This figure represents the relative magnitude of each evaluated risk factor when compared to its peers. While each concept has its individual risks, Power and ISR stand out as areas of high risk in most of the concepts.

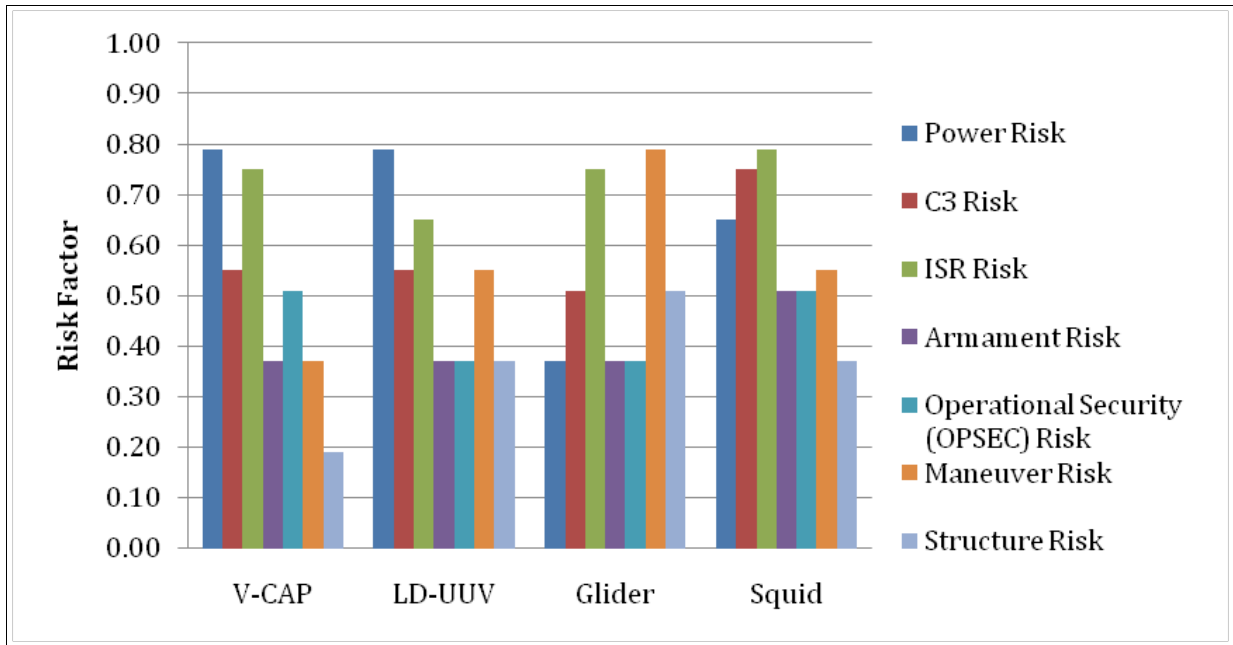

Figure 5.24: Individual Criteria Risk Factors for AUWS concepts

Figure 5.25 depicts the relative risk factor of the four AUWS concepts in terms of the weighting of the technical, schedule, and cost consequences. Technical risk stands out as the broadest concern. At least one of the concepts is considered low risk with regard to both cost and schedule; however, none of the concepts are considered low technical risk.

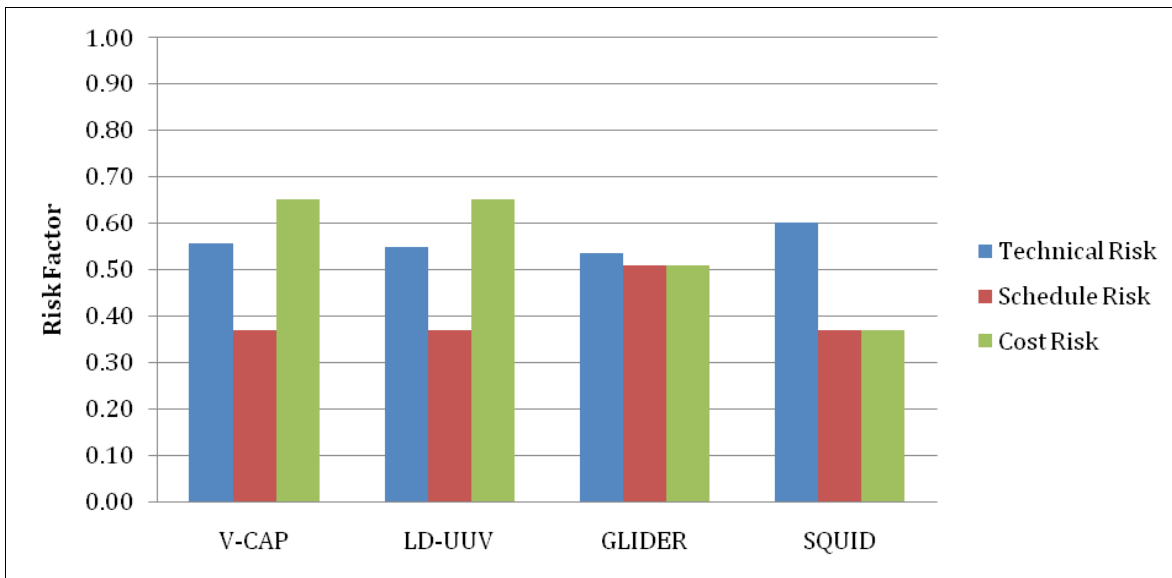

Figure 5.25: Consequence Risk Factors for AUWS concepts

This risk analysis will aid decision makers in choosing the best system based on a better understanding of the relative risks associated among system designs. Additionally, critical areas within each system have been clearly identified and will further assist in mitigating adverse effects on the project life cycle due to unforeseen risks.

5.4 Comparison to the Status Quo

An important option to consider when confronting any challenging problem is to simply maintain the status quo. Often, a cost-effectiveness or risk analysis dictates that developing a new system would not be beneficial. This analysis considers how the Navy would address the generic scenario used in modeling and simulation, given that only traditional, currently available assets were utilized. The purpose is to determine if there is any benefit to investing in AUWS in the first place, and to validate the initial assumptions made regarding the advantages of unmanned systems.

The specific objectives in the modeling scenario are to monitor the area of responsibility, detect all contacts, report contacts of interest to a remote command center, and prosecute contacts designated as threats. For the purposes of this scenario, AUWS is operating autonomously and does not require permission or triggering from external sources to prosecute threats.

There are several potentially viable assets available in the current inventory worth considering capable of meeting the scenario objectives. A traditional mine field could satisfy prosecution requirements; however, current mines do not have the capability to discriminate between threat and non-threat. Target detection technology could be improved upon to provide discrimination, but such improvement would require a significant investment on par with developing AUWS. If a traditional mine field were employed, the area of responsibility would be denied to *all* traffic. Furthermore, airborne assets would be required to deploy the mine field, since the fleet is currently phasing out the Submarine Launched Mobile Mine. Additional airborne or surface assets would be required for ISR and communication purposes. This complex, costly approach would most likely be unable to achieve all of the scenario objectives.

A small group of surface combatants, such as LCS, could meet scenario objectives; however, the presence of warships eliminates the possibility of covert operations and could likely be provocative or otherwise undesirable in many of the littoral areas being considered.

On the other hand, a single Virginia Class SSN could achieve the ISR, communication, and prosecution objectives while remaining covert. The SSN could be utilized to collect ISR data in the area of responsibility. The area to be evaluated is 10 NM by 3 NM and a depth of 300 ft. An SSN's detection capabilities far exceed this range. Surface contacts could be localized and identified with a high degree of confidence, via electro-optical sensors, while submarine contacts would require several hours, possibly days, for identification. Localization of threat submarines would also be time consuming with a single SSN. The addition of a second SSN would significantly increase threat submarine localization capabilities, but would also effectively double the already substantial cost and risk of the operation.

While a SSN possesses several methods of communicating with a remote command center, the Commanding Officer and crew mitigate the need for most external communications. The CO is able to make many tactical decisions without higher approval (i.e. act autonomously), while sensor operators can process sensor data into tactically relevant information so that the messages that do need to be transmitted are greatly reduced in size.

An SSN could remain in the area for approximately 90 days undetected, easily satisfying the identified need for endurance and persistent presence. An SSN's endurance is limited primarily by food storage capacity. It is therefore reasonable to assume that unmanned systems have the *potential* for greater endurance. Nuclear power is not likely to be a viable near-term option for unmanned systems, significant further research and technological development is required in this area.

5.4.1 Performance Assessment

Overall mission effectiveness of an SSN is evaluated as being very high. Confidence in prosecution effectiveness is based primarily on the proven capabilities of the Mk-48, Mod-6 torpedo. These torpedoes have been highly tested and have proven very effective. SSNs use sophisticated, multi-faceted sonar suites, such as the BQQ-10,¹³¹ to assist operators in detecting vessels. Powerful sensors and onboard data processing capabilities produce a high level of confidence in detection. Submarines also have state of the art communication suites, which allow

131 IHS Global Limited. "Jane's Underwater Warfare Systems: AN/BQQ-10." 23 Jul. 2010. *Janes.com*. 21 Apr. 2011 <http://search.janes.com.libproxy.nps.edu/Search/documentView.do?docId=/content1/janesdata/yb/juws/juws2014.htm@current&pageSelected=allJanes&keyword=BQQ-10&backPath=http://search.janes.com/Search&Prod_Name=JUWS&>.

them to transmit and receive data reliably with minimal time latency. If mission dictates, they can maintain persistent communications and contribute to the common operating picture.

The status quo alternative, based on a single SSN, is highly effective with regard to detection, communication, and prosecution. Assuming that AUWS could match the SSN's performance in these critical functions, other areas still favor the SSN. They do not have to rely on additional assets for deployment or recovery, essentially mitigating that area of need. The presence of the CO and crew gives the SSN a clear advantage in threat discrimination, because they can designate a contact as a threat without having to communicate externally or rely on a computer to make the decision. Overall, the SSN is deemed as superior to AUWS with respect to performance alone.

5.4.2 Cost Assessment

An SSN has an average annual operating expense of \$21 million.¹³² Using a 30 day operating scenario, that equates to about \$1.75 million. Assuming the SSN expends eight Mk 48 ADCAP torpedoes over the course of the scenario,¹³³ the total cost of the operation is about \$30 million.¹³⁴ Strictly considering the cost analysis in this report, an SSN is a significantly more expensive alternative than any of the AUWS concepts.

There is significant debate, however, as to the long term cost savings potential of unmanned systems over manned systems, particularly with regard to personnel costs. For example, UAVs require dozens of operators, maintainers, and analysts to successfully conduct a mission. Simply unmanning a vehicle does not alleviate personnel requirements, it merely displaces them. In fact, Congress noted in 2003 that "while the acquisition per unit cost [of UAVs] may be relatively small, in the aggregate, the acquisition cost rivals the investment in other larger weapon systems."¹³⁵

Assume, as a worst case scenario, that AUWS produces no cost savings over the SSN alternative over the system life cycle. In this case, only performance and risk would factor into the decision of whether or not to invest in AUWS. It will be shown that the analysis still favors

132 Naval Center for Cost Analysis. Naval VAMOSC. 1996. 13 May 2011 <<https://www.vamosc.navy.mil/>>.

133 Average number of threats encountered in the simulation

134 Federation of American Scientists. "MK-48 Torpedo." 12 December 1998. *FAS.org*. 25 Apr. 2011 <<http://www.fas.org/man/dod-101/sys/ship/weaps/mk-48.htm>>.

135 United States Cong. Bob Stump National Defense Authorization Act for Fiscal Year 2003. Washington: GPO, 2003. 243.

investment in AUWS, even with cost ignored. If in the future, however, life cycle cost of any AUWS concept is found to be greater than an SSN, then investment is not recommended.

5.4.3 Risk Assessment

With the four system concepts for AUWS, areas of risk analyzed are cost, schedule, and technical. The Virginia Class SSN, however, is a relatively mature system that relies on proven technology. Budget, schedule, and technical risks are negligible. With the SSN, there is only one risk worth considering: operational risk. An assessment of operational risk for the SSN and each of the four AUWS systems reveals a decisive advantage for AUWS.

5.4.3.1 SSN

While the probability of an SSN being lost or damaged in the given scenario is low, the consequences are severe. A Virginia Class SSN has an average unit cost of \$2 billion¹³⁶ and is manned by over 100 sailors. It also represents an operational, and sometimes strategic, asset that provides many more capabilities to the fleet than those required in the scenario. The costs of losing an SSN far outweigh the benefits of employing it in the small area of responsibility outlined in the scenario. In fact, the employment of even one SSN in this context represents a sort of risk “overkill”. If the area were larger, the SSN might be more appropriate. Still, the SSN is not tailorable to the mission at hand, so there is a very low probability that the cost, risk, and benefit of employing an SSN are appropriately balanced and suited to any given mission. The only option to improve system capability is to add an additional SSN, substantially increasing the overall inherent operational risk of the mission.

AUWS, however, can be tailored by employing the number of units that the mission and area of responsibility dictate, thereby minimizing risk “overkill”. More importantly, AUWS eliminates the direct risk to the sailor. Consequently, AUWS has a tactical advantage over adversary manned assets because the manned assets incur the vast majority of operational risk in a direct confrontation. In other words, AUWS can afford to engage in activities deemed too risky for a manned asset.

136 Booz Allen Hamilton. "Navy Virginia Class Cost Reduction Approach." 19 Apr. 2008. *Boozallen.com*. 25 Apr. 2011 <<http://www.boozallen.com/media/file/navy-virginia-class-cost-reduction-approach.pdf>>.

5.4.3.2 Glider

Glider, like all AUWS system concepts, benefits from being an unmanned system when it comes to operational risk. The system is not without any operational risk, however. Gliders rely on ballast shifting and vertical movement in the water column for mobility. This analysis assumes that the gliders employed in the AUWS system will have the ability to maintain an average two knots in periodic, shifting currents up to five knots. It is recognized that this represents a significant technical risk, as current gliders are only able to maintain about half a knot. As discussed previously, 64 times the power would be required to achieve the desired speeds when assuming that power varies as the cube of velocity. Even if such speeds could be maintained, extreme weather and other unpredictable aspects of the maritime domain could inadvertently force the gliders out of their operational area. If the gliders cannot remain on-station in their designated area, they essentially become a drifting mine field, which is a violation of current international law and a significant political liability.

5.4.3.3 LD-UUV

LD-UUV is the least tailorable of the four AUWS system concepts. There is some potential for this system not being appropriately suited to the mission with regard to operational risk. Still, this problem of tailorability is negligible when compared to the SSN. The primary risk to the LD-UUV concept is the desire for size increase that is currently trending in the community of interest. In an attempt to quickly solve power density problems and/or add more capabilities to unmanned systems, many stakeholders are advocating that all large diameter UUVs be built even bigger. While a size increase would certainly alleviate performance problems, the vehicles themselves would become more valuable. With more and more capabilities added and an ever increasing unit cost, eventually the loss of a single LD-UUV would be considered unacceptable – not unlike the SSN. Nevertheless, the LD-UUV concept, as modeled, is considered to have a low operational risk.

5.4.3.4 Squid

There are several operational risk concerns for the Squid concept. One of the primary methods of deployment, via naval artillery, introduces the risk of hitting neutral or friendly assets in the area of responsibility. Even if no collateral damage occurs, the firing of naval guns into

foreign littoral areas could be seen as escalatory and incite unwanted hostilities. The method of prosecution is also cause for concern. The magnetic shape charges rise upward toward a target's hull via positive buoyancy. If an explosive misses its intended target, it must be rendered inert immediately, otherwise it might attach to a neutral or friendly hull. It is essentially a drifting mine by the nature of its functionality.

5.4.3.5 V-CAP

The V-CAP concept is evaluated as having the lowest operational risk of all AUWS concepts. The mobility of V-CAP allows flexibility in deployment and recovery to accommodate areas of heavy traffic or political sensitivity. Like LD-UUV, V-CAP is anchored to the seabed during operation so there is no concern for weapons inadvertently drifting out of the area of responsibility. Also, threat prosecution is accomplished via precision attack torpedoes, reducing the risk of collateral damage. Unlike LD-UUV, however, external communications (gateways) and data processing can be easily distributed. More than one Hunter unit can be employed to eliminate a single point of system failure. Multiple LD-UUVs could also be employed, but the V-CAP concept is a more tailored cost-effective solution.

5.4.4 Comparison to the Status Quo Summary

The Navy could accomplish all of the mission objectives in the given modeling scenario with its current force structure, but an undesirable operational risk would be incurred. Any of today's SSNs most likely would perform better in the given scenario than AUWS, at least the first generation of such systems. Keeping this in mind and ignoring the potential for cost savings, the comparison of AUWS vs. the status quo alternative comes down to a risk-benefit analysis. An analysis of risk, specifically operational risk, heavily favors AUWS over an SSN. All of the AUWS concepts have their own operational risks, but those risks, particularly those associated with LD-UUV and V-CAP, are negligible when compared to the SSN. It has been shown through modeling and simulation that, by employing more units, AUWS can be tailored to improve performance to a level on par with a SSN, while still maintaining a lower overall operational risk.

It is also worth noting that some of the advantages of unmanned systems over manned systems are not as clear cut as initially assumed. For example, an SSN's ability to provide

persistent forward presence far exceeds that of current unmanned systems. While unmanned systems have the capability of lying dormant nearly indefinitely, significant technological progress must be made in the area of power density for unmanned systems to have an operationally relevant advantage over manned systems. Operational cost is not a clear advantage for unmanned systems. Certainly, the potential for cost savings exists, but it is yet to be proven.

5.5 Recommended Alternative

With the advantages of AUWS over the status quo, the results of performance, cost, and risk analyses are synthesized to make system recommendations. The results of all analyses can be combined to form a top-level preference score, with variable emphasis given to each factor. This preference score must use proper weighting to provide a meaningful recommendation. To examine the impact of the weighting for each factor, an overall sensitivity analysis is required.

5.5.1 Overall Sensitivity Analysis

Starting with scaled scores for performance, cost, and risk for each alternative, an equal weight of one-third is used to multiply each factor's data to produce a score between zero and one for each alternative. The same methodology used for the performance sensitivity analysis is applied here. For each factor, the weight is increased to one while the remaining two factors are brought to zero. A linear equation is developed representing the change in final scoring due to change in weighting. Those four equations are plotted against each other to determine crossover points in the weighting at which the rank order of alternatives would change.

5.5.1.1 Performance Sensitivity

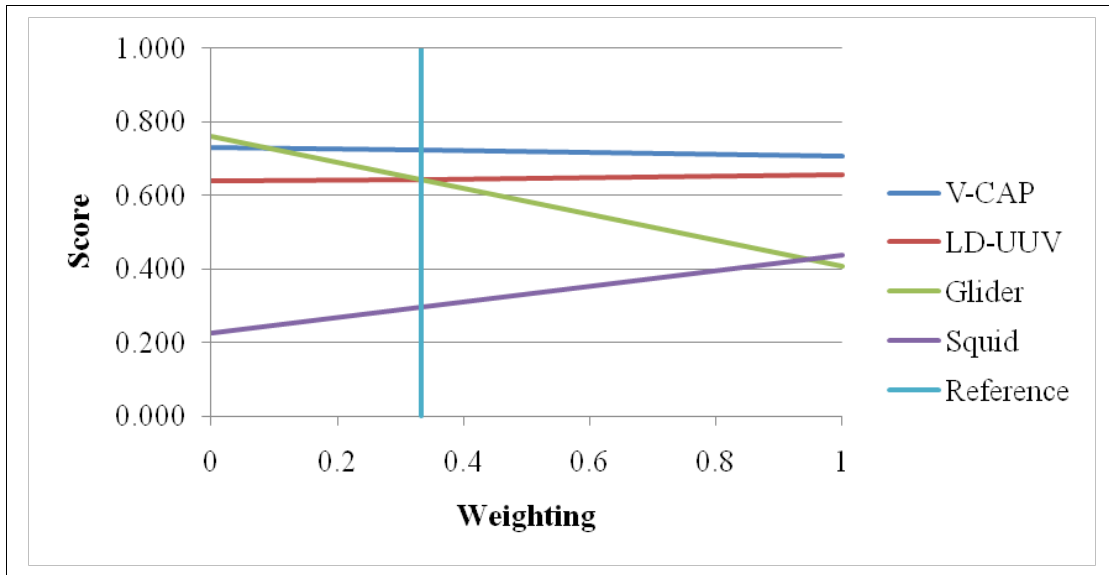

Figure 5.26: Performance Sensitivity

The vertical line in Figure 5.26 represents the initial one-third weighting for performance. At no reasonable point would a change in performance weighting cause V-CAP to lose the top ranking. Glider's overall score drops dramatically as the performance weighting is increased, starting in first place and ending in last. The relatively low cost and low risk factor make Glider a very desirable concept if performance is not a concern. There is significant sensitivity between LD-UUV and Glider, which indicates that either concept may be superior depending on how much performance is valued over cost and risk. Squid's score is almost inversely proportional to Glider's, with a score that rises with increased performance weighting, most likely due to reasonable communications times and detection capability discounted by excessive cost.

5.5.1.2 Cost Sensitivity

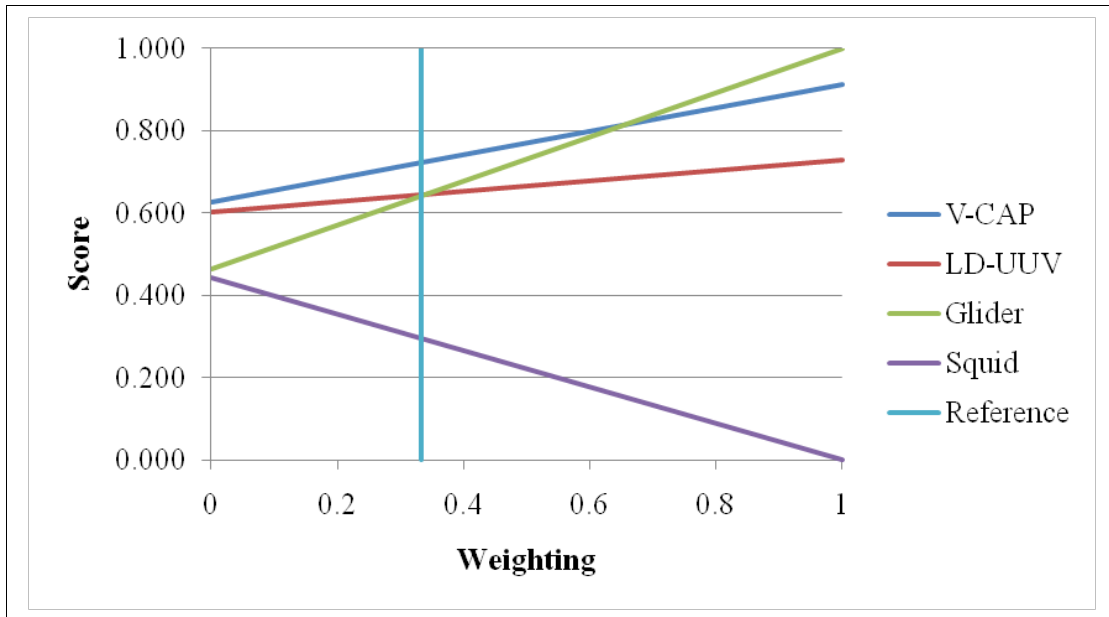

Figure 5.27: Cost Sensitivity

Figure 5.27 shows clear-cut changes in scoring for all concepts for variations in weighting. Only a doubling of the cost weighting will cause Glider to unseat V-CAP as the top alternative. Glider's impressive scoring as cost weighting increases is indicative of its high cost-effectiveness. Glider and Squid also repeat the performance analysis trend of having nearly inversely proportional equations. Squid, being the most expensive alternative by a significant margin, has a declining score. Once again, LD-UUV's performance is very similar to that of V-CAP, albeit slightly lower. The intersection of Glider and LD-UUV near the reference line is again indicative of their nearly indistinguishable overall utility.

5.5.1.3 Risk Sensitivity

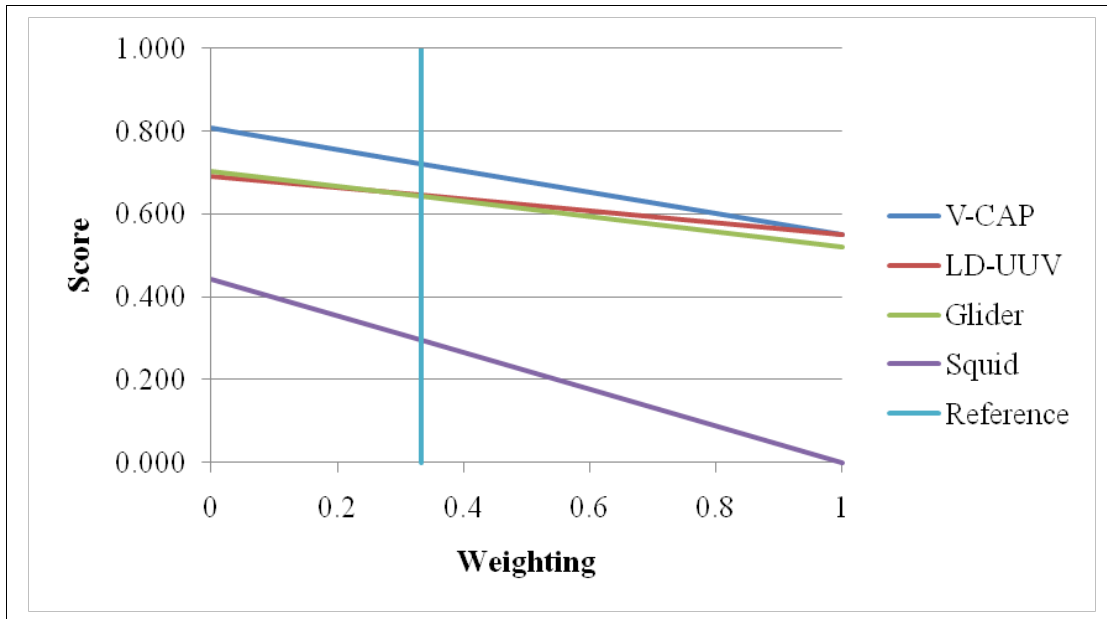

Figure 5.28: Risk Sensitivity

The risk score for each concept is fairly similar to cost, except each concept's score decreases as weighting for risk increases, illustrated in Figure 5.28. V-CAP remains dominant regardless of how much weight is given to risk. Glider and LD-UUV once again intersect near the origin; however, the two linear equations are so similar throughout the entire range that the intersection is virtually meaningless. The risk inherent to Squid is apparent from the wide gap between its score and the others.

5.5.2 Recommended Alternative Summary

The overall sensitivity analysis makes it apparent that only a major disparity in rankings for performance or cost will result in a different result for the top alternative. Glider is the only system that is affected by a major change, because its poor performance could be compensated for by low operational cost; if cost were worth at least 60% or performance were ranked at less than 10%. By this logic, a final recommendation is made on the grounds that performance, cost, and risk are equal in weight for the purposes of decision-making. Figure 5.29 depicts the overall score of each alternative given equal weighting to the three factors.

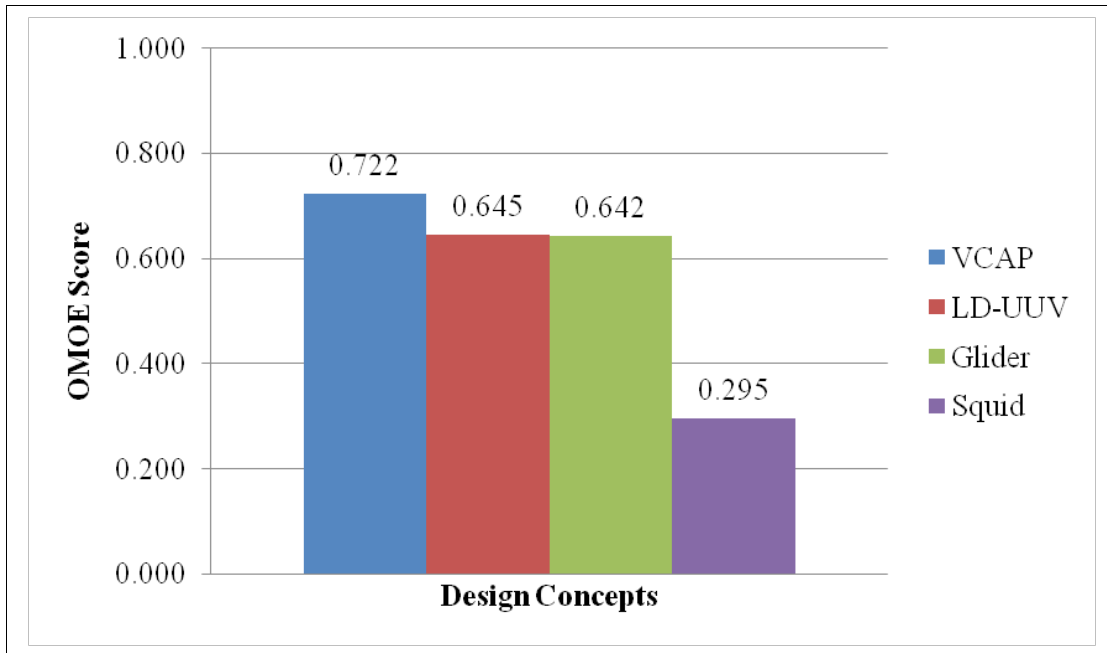

Figure 5.29: Overall Concept Scoring

Squid can be readily discounted, leaving three concepts for consideration on first glance. V-CAP has superior utility when there is a desire to balance performance, cost, and risk equally. Glider and LD-UUV are nearly indistinguishable in utility. Both are reasonable alternatives, especially considering that their overall scores are only about 10% lower than the apparent front runner. Neither should be discounted off hand.

Figure 5.29 is useful, but it does not tell the whole story. Figure 5.30 completes the picture with a Cost as an Independent Variable diagram of performance.

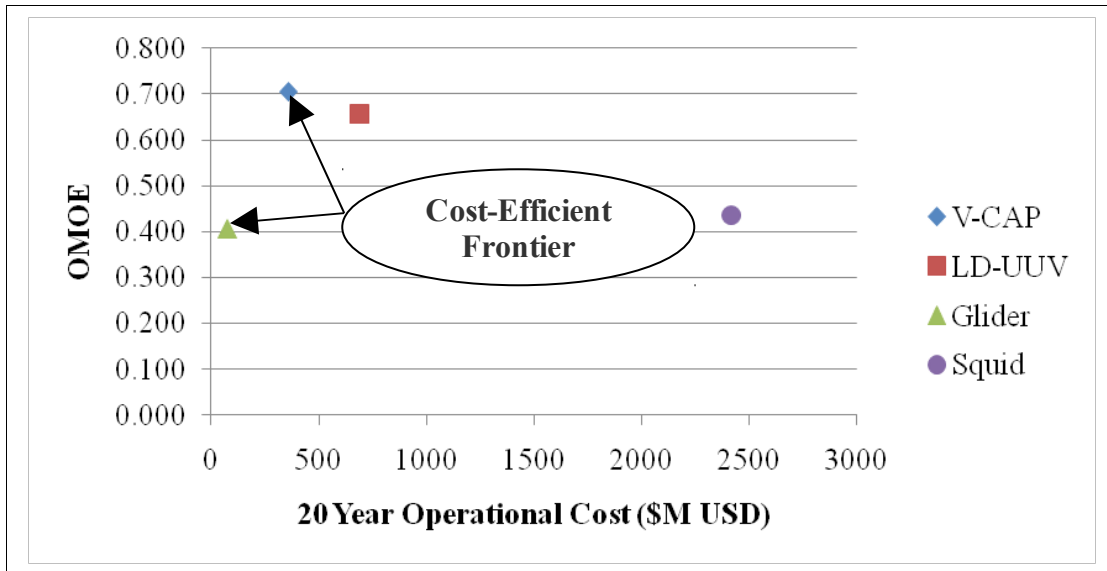

Figure 5.30: Cost vs. Performance

Figure 5.30 shows the four concepts in space relative to cost on the horizontal axis and performance on the vertical axis. Glider and V-CAP are on the “cost-efficient” frontier, as they are furthest in the direction of high OMOE and low cost. Squid is significantly more expensive than any other alternative, providing almost 30% lower performance than the next-highest alternative at more than five times the cost. V-CAP and LD-UUV are closely grouped, providing similar performance and cost values.

Glider, V-CAP, and LD-UUV are all cost- and risk-effective alternatives; however, Glider is not currently recommended for investment for two reasons. First, there is no significant comparative advantage between LD-UUV and Glider from almost any analytical perspective. Since the Navy is already invested in LD-UUV research and development, it does not make good business sense to invest in a new concept that is projected to only provide the same amount of utility. Second, the significant operational risk outweighs Glider’s high endurance and cost-effectiveness. It is recommended that the Navy wait until glider technology has advanced to the point that the vehicles can reliably maintain station in the most stressing environment conditions before investing in the AUWS Glider.

V-CAP and LD-UUV are recommended for potential investment, pending further analysis. While V-CAP costs less, performs better, and has a risk factor equivalent to LD-UUV, it is not the obvious choice. There are factors outside of the scope of this analysis as well as

intangibles that may drive a decision in favor of LD-UUV. V-CAP is the winner of this analysis, but LD-UUV cannot be discounted due to the similarity of the overall results. For this reason, V-CAP and LD-UUV are both recommended for further analysis.

6. Concept Evaluation Recommendations

The primary and secondary concept recommendations, V-CAP and LD-UUV respectively, are now discussed in detail to aid decision makers in utilizing the results of this analysis. This discussion includes a refined description, recommended improvements, updated Concepts of Operation, and an examination of the trade-offs in terms of advantages and disadvantages. In addition, a fusion of concepts to develop a more robust solution is considered, followed by recommendations on system verification and validation.

6.1 Primary Concept Recommendation: V-CAP

V-CAP's baseline configuration is a pair of modular, configurable, torpedo-shaped UUVs. The two units are sized to fit a 21 inch torpedo tube, and are 19 feet in length in heavyweight configuration (12 feet in length for lightweight configuration). The UUVs consist of a series of functional modules that can be swapped for upgrades, maintenance, or mission tailoring, or removed to reduce weight and displacement to support airborne deployment. At least two units, a Hunter and Killer, must be deployed to provide minimal coverage. Increasing the number of Killer Units increases the size of the prosecution area and the number of targets that may be engaged before the system's magazines are depleted. Increasing the number of Hunter Units improves the size and quality of the sensor footprint area and provides additional communication gateways and visual ISR nodes. Each proposed operational area must be analyzed prior to deployment to determine the appropriate number and type of V-CAP units that must be employed.

The Hunter Unit nominally consists of a propulsion module, a control module, a network module, a sensor module, and a communications module. The propulsion module contains a scaled-down OTTO fuel II engine and fuel tank, a battery, and electric drive components to augment the engine. The network module is essentially a magazine that holds deployable communications and sensor nodes. The control unit houses the UUV's C3 suite, CPU, and guidance system. The sensor module contains a conformal, cylindrical passive sonar array. The communications module contains a deployable tethered buoy equipped with communications antennae and visual sensors.

The Killer Unit consists of a propulsion module, a network module, a munitions module, and a control module. The propulsion, network, and control modules are identical to those installed on the Hunter Unit. The munitions module ideally holds multiple miniature torpedoes, but can be replaced with a larger single round warhead or different mission-specific munitions.

6.1.1 Improvements

V-CAP's performance is on par with LD-UUV's, with the two concepts trading top scores in most areas across the board. Lethality, deployability, and recoverability are the areas in which V-CAP has a marked advantage. These advantages (along with endurance, only three days shorter than LD-UUV's) are driven by the size and configuration of the V-CAP system.

Originally envisioned as a single torpedo-shaped configuration, V-CAP has evolved from a heavyweight design (Mk 48) to a lightweight design (Mk 54) to a modular, hybrid design. The results of the cost-risk-effectiveness analysis, and associated sensitivity analyses, highlight the value of such modularity. When performance analysis is conducted on a lightweight variant (12 feet in length), LD-UUV becomes the superior concept. V-CAP is still the more cost- and risk-effective alternative, but there is significant sensitivity between the two concepts. In other words, there is less confidence that V-CAP is truly the superior alternative when considering the lightweight variant alone. By designing V-CAP as a modular 21 inch diameter torpedo shape, the concept outperforms all others because it can be tailored to the specific mission. The strength of V-CAP lies in its tailorability.

The following list discusses the points that drove the evolution of V-CAP to a system of modular, configurable UUVs:

- A 12 foot long lightweight V-CAP unit will require a "sabot" or similar device to fill up the rest of a submarine torpedo tube to prevent damage to V-CAP or the submarine prior to and during launch.
- P-8 launch will not be possible without a glider or similar attachment for the weapon due to the high altitude at which the torpedo must be launched.¹³⁷ Current testing of lightweight torpedo launches from altitude show that the P-8 torpedo launch system requires an additional delivery vehicle to slow the weapon down to avoid damage on

¹³⁷ Raytheon, "Raytheon Ready to Help India Reach its Goals", 15 Feb. 2010. 11 May 2011, <http://www.raytheon.com/newsroom/feature/rtn_insight_india/index.html>.

impact and to actually deliver the weapon to the preferred target. Current fleet paradigms are based on P-3 low-altitude, low-speed launches, not high-speed, high-altitude launches synonymous with a platform derived from the commercial variant of the Boeing 737.

- No variant of V-CAP can be launched with existing surface torpedo launchers; no matter the size, a 21 inch weapon can only be deployed via crane or davit, not tube launched.

Based on these three points, a tradeoff analysis emerges for the design of the V-CAP, consisting of four different options:

- Mk-54 shape V-CAP
- Lightweight V-CAP (21 inch diameter by 12 foot length)
- Heavyweight V-CAP (21 inch diameter by 20 foot length)
- Modular V-CAP (21 inch diameter with removable sections to change length and weight, including scaled down propulsion, fuel, battery, and warhead sections for deployment and mission tailoring)

A Mk-54 variant of the V-CAP would limit the battery size of the unit, and therefore, the endurance of the system. Calculations show a 50% decrease in endurance given a nominal 50 NM inbound and outbound transit. Further, this would limit the warhead size (and therefore lethality and range of the weapon). With regard to deployability, air launch would be possible via a secondary delivery device,¹³⁸ and surface launch would be relatively simple via existing launchers, but submarine launch would be hindered by the need for a launching canister. Further, the unit could not be deployed by submerged assets as a defensive torpedo round.

A lightweight V-CAP variant would maintain the ability to launch submunitions, increasing lethality, but the short length would negatively impact endurance. Surface deployment would only be possible via crane or davit, as surface ship torpedo tubes are not designed to fit 21 inch rounds. Submarine launch would still require a canister and the ability to employ V-CAP as a defensive round would still be absent.

A heavyweight V-CAP would improve endurance to match LD-UUV, as well as improve the number and size of submunitions, improving lethality. Airborne launch would be impractical due to size and weight restrictions and surface deployment would still be over-the-side, pending

138 Raytheon.

development of new surface torpedo launchers. Submarine launch would be significantly simplified as no canister would be required, and the unit could be launched as a defensive round.

A configurable variant with modules that could be added or subtracted to lengthen or shorten the unit (therefore adjusting the weight of the unit) not only allows tailoring of mission specific components and simplifies upgrade and maintenance, it provides airborne and surface deployment capability and the same submarine launch capability as a 21 inch heavyweight round, all while maintaining lethality.

It is evident that V-CAP must be fielded as a modular system with multiple configurations despite the assumed increase in risk and procurement cost due to the added complexity. The modular design could result in reduced maintenance costs, which could offset the procurement cost increase over the system life-cycle.

6.1.2 Concept of Operations

The appropriate number, type, and configuration of V-CAP Hunter and Killer Units will be deployed directly into the operational area or from a safe distance away from the operational area, as deemed necessary by the Operational Condition (i.e., whether clandestine insertion is a priority). P-8 or similar aircraft will drop V-CAP units from bomb-bay or wing mounts. Surface ships will deploy V-CAP by modified torpedo launchers or via cranes. Submarines will deploy V-CAP units from torpedo tubes, Vertical Launch System Tubes, or Multiple All-up-round Canisters. Depending on the deployment zone, the V-CAP units will initialize and transit to the programmed operational area, or set up for operations if dropped directly into the operational area.

Phase Zero – Shape: During the shaping phase, V-CAP units will set up an ad-hoc network by dropping communications/sensor nodes from their network module magazines. The nodes may be dropped in a pre-determined pattern, or placed by V-CAP autonomously based on in-situ judgment.

Following the deployment of the network, the Hunter and Killer Unit(s) will moor on the seabed in the center of their respective portions of the operational area. The Hunter Unit will settle vertically with the propulsor on the seabed and the nosecone pointed at the surface. The sensor and communications modules will detach from the main body, but will remain connected

via tether. The sensor module's sonar array will rise to a given stratum optimized for acoustic detection. The communications node will deploy a buoy that will sit on the surface and serve as the system's antenna and gateway to external networks. Visual ISR sensors will be located on the buoy to provide "periscope" capability. The control unit will remain attached to the main body and establish communications with the network of nodes and the other V-CAP units.

The Killer Unit will moor on the seabed within acoustic communication range of a node or Hunter Unit. The unit will settle vertically with the propulsor on the seabed and nosecone pointing towards the surface. The munitions module will open, exposing multiple miniature torpedoes aimed upwards. In the event a single warhead is utilized, the weapon will remain dormant awaiting a kill order to launch as a full torpedo. The control unit will establish communications with the node network and the other V-CAP units.

The V-CAP system will provide ISR coverage of the region in the acoustic and visible spectrums. V-CAP will conduct covert collection of all vessels passing through the operational area, taking note of any specific threat contacts required by the mission profile. This information will be used to develop the system's internal situational awareness, as well as provide the operational commander with inputs to the Combined Operational Picture, as EMCON allows. The system will conduct posture and EMCON adjustments to avoid detection and possible compromise by threat assets.

Phase One – Deter: In addition to providing general situational awareness, V-CAP will provide early warning of large or significant threat fleet movements, including en masse homeport shifts, and armadas leaving homeport. Given proper authority under ROE or under specific control or guidance, the V-CAP system may function as a smart minefield. If the United States announces the presence of a minefield to the enemy, V-CAP can then engage any target or specific threat targets, setting up an exclusion zone. V-CAP would work purely in a reactionary/defensive posture in this phase, providing hold-at-risk capability without risking traditional manned assets.

Merely the possibility of V-CAP's presence will serve to deter and disrupt enemy operations. The relatively small size of V-CAP units permits the use of decoys. Unarmed and/or randomly transmitting units can be employed in an operational area to increase overall fleet effectiveness at a minimal cost.

Phase Two – Seize: In the event of open hostilities, V-CAP will be able to change position to improve engagement capability or actively prosecute targets from an offensive posture, providing a relatively cost-effective and low-risk attack asset. Submarines and other high value assets will be free to conduct missions tailored to their unique capabilities.

Phase Three – Dominate: In Phase Three, V-CAP can actively defend inbound or on-station friendly assets by denying threat contacts freedom of maneuver via an area-denial operation. Free of close-range threats, friendly assets may establish regional control of the seas. The high-endurance, persistent, and capable V-CAP system may provide continuous coverage as long as it is needed. Since V-CAP units can be readily and affordably replaced, the risks of such dangerous missions will be acceptable.

Phase Four – Stabilize: The V-CAP system will serve as a force multiplier during de-escalation and stabilization efforts. As manned assets retire from the region, in-place V-CAP networks will continue to provide physical security for high value assets and ISR for situational awareness. The last asset to leave a region may well be V-CAP, especially considering its ability to operate independently of a manned asset.

6.1.3 Advantages

- **Deployability:** V-CAP's relatively small displacement makes it deployable by air, surface, and submerged assets.
- **Expandable Employment:** V-CAP can be affordably scaled up by simply committing more units to an operation thus improving the coverage, lethality, and follow-on engagement capability of the system.
- **Tailorability:** Depending on the mission and the number of units available, V-CAP units can be equipped with additional payloads (i.e. a second network module to increase the size of the deployed node network) that can be substituted by on-station crews prior to system deployment.
- **Renewability:** After Killer Units expend their weapons magazines, or when units reach the end of their battery capacity, they can be replaced on station with more V-CAP units.
- **Multi-functionality:** If needed, the Killer Units may be launched as torpedoes. This allows deploying submarines a flexible self-defense posture when preparing to insert V-

CAP in a hostile region because valuable torpedo tube space is not monopolized by assets that cannot be used for self-defense.

- **Upgradeability:** The modular construction of each V-CAP unit allows for the upgrade of the system via the substitution of mission modules. New munitions, sensors, network nodes, control systems, and propulsion systems may be added with minimal cost. Further, modified V-CAP configurations could be employed as mobile ISR platforms or as payload delivery systems to insert smaller UUVs into restricted areas.
- **Cost-effectiveness:** V-CAP can employ technologies and improvements in torpedo design to enhance V-CAP's design and utility. Conversely, monies expended on V-CAP improvements may be used to improve torpedo technology.
- **Redundancy:** The relatively small size of V-CAP and the versatility of its deployment allows more units to be carried per asset, improving redundancy and multiplying utility without limiting other mission capabilities of deploying assets.
- **Expandable Visual ISR Coverage:** V-CAP can provide a larger visual ISR sensor footprint by launching more Hunter Units.

6.1.4 Disadvantages

- **Complexity:** The use of segmented and deployable modules on the Hunter Unit raises complexity, which may affect maintenance and reliability.
- **Utility Limitations:** The amount of equipment required to fit within the V-CAP may result in limitations on the effectiveness (i.e. range, bandwidth, battery and fuel capacity, warhead payload, etc.) of the system. Of further concern is whether or not the system will have sufficient effectiveness in a lightweight configuration (those variants intended for air deployment).
- **Lethality:** The use of miniature torpedoes limits the warhead size, and therefore lethality of the system. These miniature torpedoes may provide a mission kill by taking out a high-value asset's rudder or propulsion system, or inducing flooding sufficient to hinder operations, but it is unlikely that an adversary would be sunk without expending several rounds. Limited lethality would require more Killer Units to be deployed, increasing the

drain on deploying asset strike or ASW engagement capability, as well as increasing the cost of operations.

- **Follow-on Salvo:** The baseline configuration of V-CAP assumes only two miniature torpedoes per Killer Unit. A single pair of V-CAP units would have a very small follow-on salvo capability.
- **Procurement Cost:** The amount of units needed to conduct missions may make the actual procurement of V-CAP so expensive that only limited numbers of units enter fleet service. As limited resources, they may not be readily available for every mission, or they may be sparingly employed by operational commanders for fear of the loss of expensive assets.

6.2 Secondary Concept Recommendation: LD-UUV

LD-UUV is a more conventional concept; there are similar systems in existence today. Essentially, LD-UUV is an unmanned miniature submersible. A device sized to fit within the 87 inch diameter tubes intended for Multiple All-up-round Canisters or Special Operations Force equipment on SSGNs and future Virginia class SSNs, the LD-UUV has plenty of internal space and payload capacity to support weapons and sensor delivery. Further, the system may be used for delivery of other complementary systems. For instance, a separate ISR UUV unit may be carried in place of or in addition to weaponry. Baseline configuration includes a set of 16 deployable, paired nodes and up to four lightweight torpedoes.

6.2.1 Improvements

Conceptually, LD-UUV is a graduation of NSWC Panama City Division's L2D2-UUV design, essentially an automated conversion of a SEAL Swimmer Delivery Vehicle, which is less than 60 inches in diameter.¹³⁹ In the interest of fully exploring the utility of large vehicles and making best use of available deployment space, the LD-UUV is graphically and stochastically modeled as a miniature submarine with an external diameter of 80 inches and no protrusions other than the control surfaces on the stern. This streamlined cylindrical shape reduces drag and simplifies storage on deployment and recovery platforms; however, use of this shape precludes

¹³⁹ Naval Surface Warfare Center, Panama City, "Large Diameter, Large Duration Unmanned Undersea Vehicle (L2D2-UUV) Initiative." Panama City: Department of the Navy, 2010.

the use of externally mounted ordnance or sensors, reducing the magazine size and lethality of the system.

In the same way that V-CAP's modular design allows it flexibility in payloads, a modular configuration (similar to the L2D2-UUV)¹⁴⁰ would allow LD-UUV to be mission tailored as well. As smaller weapons are developed, new launch modules could replace the existing unit. New propulsion, sensors, or deployables could be introduced rapidly, and AUWS could be employed for a wider range of missions, such as long distance payload delivery.

6.2.2 Concept of Operations

LD-UUV will be deployed from a submerged asset's large diameter payload tubes or from a surfaced asset's crane at a safe standoff range from the operational area. Presumably only one unit will be carried by each asset to minimize the impact on each asset's payload or strike capability. The LD-UUV will transit to the center of the desired operational area and deploy a series of paired sensor and communications nodes in a pre-determined pattern within the area. These nodes will form an ad-hoc network of undersea acoustic tripwires to determine the presence and classification of contacts passing through the area.

Following deployment of all sensor nodes, LD-UUV will take station on the seabed in the center of the operational area and assume a passive posture. The system will deploy a tethered communications buoy with external communications antennae and visual ISR systems. This buoy may be reeled in rapidly to reduce the risk of detection.

Phase Zero – Shape: During Phase Zero, LD-UUV will be deployed covertly outside of an operational area, transit to the operational area, and set up an ISR network before shifting to a passive EMCON posture. From the resting position in the middle of the operational area, LD-UUV will fuse acoustic, visual, and electronic signatures to detect, identify, and catalog passing contacts, building an internal operational picture and broadcasting this information to assist the operational commander in developing a Combined Operational Picture.

Phase One – Deter: Much like V-CAP, LD-UUV will provide an early-warning capability by notifying friendly forces of adversary fleet movements. In the event of these fleet movements, LD-UUV will also provide hold-at-risk capability as a smart minefield, restricting enemy forces from exiting port or transiting a critical area. The employment of LD-UUV can be

¹⁴⁰ Naval Surface Warfare Center, Panama City.

feigned just like V-CAP for deterrence and disruption; however, the larger vehicle size will likely make decoys more costly.

Phase Two – Seize: During open hostilities, LD-UUV will use its organic capability to attack targets. Lightweight torpedoes will give LD-UUV a large “bang for the buck,” by giving the system a real capability to destroy high value assets.

Phase Three – Dominate: During Phase Three, LD-UUV will function as an area-denial tool by restricting enemy movement while allowing friendly forces to take station and establish regional control of the seas.

Phase Four – Stabilize: During the stabilization phase, LD-UUV can continue to provide ISR capability to enhance friendly force operations while providing physical security to friendly assets. Just like V-CAP, LD-UUV may well be the final asset to retire from the operational area.

6.2.3 Advantages

Payload: LD-UUV’s size and displacement allow it to be used as a delivery method for other systems or weapons with little or no modification. For instance, LD-UUV could carry small UUVs instead of lightweight torpedoes.

Proven Technology: the technological risk for the majority of required systems is low because less miniaturization is required due to the large size of each unit.

Improved Sensing and Communications: The use of hardwired nodes improves the accuracy of detections and the speed at which a detection can be made, classified, and transmitted. Threat discrimination is further enabled through the use of parallel processing among the networked sensor nodes.

Lethality: The use of lightweight torpedoes insures that LD-UUV can provide a significant lethality to eliminate high value assets vice provide a mission kill. This strength gives LD-UUV a better deterrence value, as well.

Upgradeability: LD-UUV’s modular internal configuration allows for rapid insertion of improved components.

6.2.4 Disadvantages

Deployability: Only surfaced and submerged assets can deploy LD-UUV due to its large size.

Large Displacement: Where a single submarine can easily launch half a dozen V-CAP units from the same large diameter tube, only one LD-UUV can be deployed. Placing a second LD-UUV on board will negate the cruise missile vertical launch capability of that submarine.

Redundancy: the compromise, failure, or destruction of the LD-UUV will most likely result in mission failure because of the difficulties involved with launching a second LD-UUV without employing more manned delivery assets.

Follow-on Salvo: for a baseline configuration, LD-UUV can only supply a maximum of four separate engagements without doubling the cost of the system by introducing a second LD-UUV.

Limited Visual ISR Coverage: only one buoy can be employed by LD-UUV, providing a smaller visual ISR sensor footprint than V-CAP, which can easily deploy multiple Hunter Units to add more visual ISR coverage in the operational area.

6.3 Comparison

The two recommended systems have very similar operational concepts; they just use vehicles of different sizes to accomplish the prescribed mission. Both systems can be deployed and recovered by a number of different platforms. Sensor and communications nodes to establish an ad-hoc sensing network prior to establishing a passive reconnaissance posture are deployed by both UUVs. From this posture, both systems have the capability to launch weaponry in order to neutralize threats. Following the completion of the mission, exhaustion of weapons magazines, casualty, or exhaustion of fuel and battery capacity, both systems may retire from the operational area for recovery.

V-CAP's small size gives it the edge in deployability, sensor footprint, redundancy, and follow-on salvo, while LD-UUV's larger displacement allows for a higher lethality, faster communications, and more accurate sensing.

6.4 Fusion of Concepts

To minimize the risks and disadvantages of either system, the key features that make each alternative the best in any given MOE might be enhanced or combined to produce improved or hybrid concepts. This enhancement is enabled by the inherent tailorability of both systems.

Consider the scaled up V-CAP system, with eight Killer Units and two Hunter Units, discussed during modeling and simulation results. Taking this concept one step further, the LD-UUV's paired nodes could be introduced to replace the V-CAP's communications and sensor nodes. The same hard-wired node configuration that realized LD-UUV's slightly superior endurance and communications times could improve the endurance (by lowering sensor power draw) of the V-CAP while speeding up communications times.

Running a model of this hybrid concept in the standard baseline modeling and simulation scenario reveals that an MCT of 3.1 to 3.4 minute can be achieved. While this result is slightly higher than LD-UUV, the difference is not statistically significant. Detection and prosecution performance is unaffected. The improvement in overall performance is to be expected, since V-CAP's modular design allows for the introduction of paired sensor nodes with minimal impact to the rest of the system. The use of an extra module may be necessary to accommodate the space used by spools of fiber optic cables.

Judging from modeling and simulation results, it is tempting to consider inclusion of Squid nodes in the hybrid concept. Squid's highly distributed, redundant sensor field enables a near perfect P_d . V-CAP and Squid could be integrated into the same ad hoc network with minimal difficulty; however, the two systems would most likely require separate means of deployment, adding operational complexity. A cost benefit analysis favors the use of V-CAP alone. A P_d of over 90% can be achieved by only doubling the baseline number of units and the valuable elements of the system can be recovered, reducing overall cost. A further increase in P_d can be achieved by adding additional Hunter Units. It is left to decision makers to determine if 99% P_d is truly worth the employment of basically two separate systems, one of which is non-recoverable.

The paired nodes utilized by the LD-UUV are the only portions of that system that provide a definitive edge over V-CAP. By adding this feature to V-CAP, the best performance aspects of all concepts may be realized without significantly increasing cost or risk.

6.5 Verification and Validation

Verification and validation are both critical feedback elements of any systems engineering process. At every phase in the process, efforts must be made to trace work products

back to the root problem statement and stakeholder requirements. This ensures that not only the correct system is being developed, but also that the system is being developed correctly.

System validation is achieved through clear and visible traceability back to the original problem, as defined by a thorough needs analysis. Both V-CAP and LD-UUV can trace their system architecture and concept of operations back to the problem statement. Each system centers on the critical physical elements, and corresponding functions, of weapons, sensors, and communicators. Each system employs these critical elements to address the seven identified areas of stakeholder needs:

- Threat Discrimination
- Detection Avoidance
- Adjustable Autonomy
- Persistent Forward Presence
- Enemy Prosecution (manned and unmanned)
- Operational Picture Development
- Platform Independence

Finally, by addressing these need areas, both V-CAP and LD-UUV provide a viable solution to the initial problem as stated below:

Over the next twenty years the capacity and capability of USW platforms will not meet operational demands in non-permissive areas. Furthermore, the emergence of near-peer competitor navies, the distributed nature of the asymmetric maritime threat, and the development of autonomous undersea threats present a unique challenge that current platform-centric solutions are not ideally designed to confront.

System verification, on the other hand, is ultimately a product of testing and evaluation. Limited verification is shown here through the use of modeling and simulation; however, a full test and evaluation program on physical prototypes is recommended to truly verify the V-CAP and LD-UUV systems. As a reference for future analysis, a notional Test and Evaluation Master Plan for V-CAP is included in Appendix J.

In addition to the systems developed, requirements must also be verified and validated. A system must be based on valid requirements in order for the system to be valid. Requirements

validation for AUWS is ultimately left to the warfighter; however, it is recommended that the need areas defined here be used as a basis for requirements definition. Given that these need areas are valid, this analysis should be a useful guide in developing an Initial Capability Document for AUWS.

7. Insights and Recommendations

The true value of this analysis lies not only in the discrimination of potential concepts, but also in the insights that can be gained and the broader recommendations that can be made based on those insights. Comprehensive analysis of alternatives gives rise to overarching principles that can be widely applied by the Navy as it seeks to develop the finest warfare systems of the future. The objective here is to inform decision makers of the operational insights gained and make recommendations on programmatic steps toward maintaining USW dominance in the future.

7.1 Operational Insights

Throughout this analysis, from initial problem definition to the results of cost, risk, and performance analyses, three principles, flexibility, scalability, and tailorability, stand out as keys to the success of AUWS. Collectively, these three principles effectively address the critical need areas for AUWS.

7.1.1 Flexibility

First, the flexibility with which AUWS can be employed is critical because it provides operational commanders with utility in a variety of circumstances. AUWS must be able to integrate flexibly with various communication networks, since all of the evaluated concepts rely heavily on relays to connect to external command centers. AUWS cannot afford to miss communication opportunities due to incompatibility.

AUWS must also be platform flexible so that it can be deployed and recovered in different situations as the mission dictates. AUWS may need to be deployed or recovered covertly, rapidly, or in large numbers; each potentially necessitating a different type of platform.

Furthermore, the long duration of AUWS missions means that the same platform that deployed the system may not be available for recovery. True platform independence, however, leads to suboptimal design and therefore must be balanced among other critical needs.

Flexibility of AUWS also applies to command and control. Routine, low level functions must be automated so that AUWS can contribute to the COP with minimal power draw and time latency of critical communications. All sensor nodes should have baseline signal processing capabilities to reduce data message sizes. Sensor nodes should also be programmed with limited

capability to prioritize the urgency of messages, mitigating the OPSEC risk of unnecessary signals. For all other functions, the autonomy level of AUWS should be adjustable based the current situation. This permits AUWS to operate even in communication degraded environments. Adjustable autonomy also enables operational commanders to manage the manpower devoted to the system, ranging from a single supervisor to many direct controllers.

It is recommended that lethal effects remain under human control until larger cultural, ethical, and political issues are resolved regarding the use of autonomous weapons systems. While many technological challenges remain, the required accuracy in threat discrimination will most likely be achieved before the larger non-technical issues are resolved. AUWS should be designed to incorporate upgrades as they become available, so that the system is ready to respond once the order is given. Intermediate steps that could be taken include the use of non-lethal weapons, such as CRAW, and doctrine that only allows weapons release in specific circumstances, such as in defense of a high value unit.

7.1.2 Scalability

The second key to AUWS success is the scalability of the system. Unlike most current platform-centric solutions, AUWS must provide the operational commander with the ability to balance cost, risk, and performance by dedicating the appropriate number of units to any given mission.

The scalability of AUWS is the primary reason that it is considered more risk-effective than current USW systems, particularly in limited littoral operations. Submarines cannot be scaled down to mitigate risk in situations that require only a fraction of their capabilities, and they can only be scaled up by allocating another submarine. By employing an appropriate number of AUWS units, operational commanders can balance cost, risk, and required performance for any given mission. Consequently, submarines can be freed up to support the fleet with their unique capabilities. The relatively small physical size of elements gives AUWS a high probability that it will be well suited to the mission without resulting in performance and risk “overkill.” Secretary of Defense Robert Gates perhaps best summarizes the need for scalable solutions in his 2009 article “Striking the Right Balance:”

“Given that resources are not unlimited, the dynamic of exchanging numbers for capability is perhaps reaching a point of diminishing returns. A given ship or aircraft—no matter how capable or well equipped— can only be in one place at one time—and, to state the obvious, when one is sunk or shot down, there is one fewer of them.”¹⁴¹

Still, there is a trade-off between scalability and flexibility regarding physical size. On one extreme, submarines represent a highly flexible but not scalable solution. On the other extreme, very small elements can be scaled precisely to mission requirements, but the limitations on power capacity and prosecution capabilities hinder flexibility. Current US Naval mines are examples of systems that are highly scalable, but relatively inflexible in their operation. AUWS should strive to maintain balance between flexibility and scalability. It has been shown that even a flexible system such as V-CAP can be scaled up to improve performance without incurring unacceptable cost and risk.

7.1.3 Tailorability

Third, AUWS must have the capability to be tailored to the specific requirements of each mission. For example, the modular design of V-CAP is one of the primary reasons for its superior cost- and risk-effectiveness. Not only can V-CAP be loaded with modules specifically suited for the current mission, but it can also be configured for submarine, surface, and airborne deployment. This tailorability allows the concept to have endurance on par with larger systems while still maintaining platform flexibility. To a lesser extent, the large internal payload capability of LD-UUV allows for mission tailoring and contributes to the concept’s overall value.

Tailorable systems can also provide a critical tactical advantage because they allow for an optimal level of redundancy in critical elements. Homogeneous networks, such as Glider, are highly redundant because each node can perform all critical functions. If a node is neutralized by the enemy, the system degrades gracefully instead of crashing because other nodes are still capable of conducting the mission. On the other hand, homogeneous networks pay a penalty in cost and/or performance because it not necessary for every single element to possess all system capabilities in order to operate effectively. Heterogeneous networks, such as V-CAP, enable

¹⁴¹ Gates, Robert M. "The National Defense Strategy: Striking the Right Balance." *Joint Forces Quarterly* Jan. 2009. 5-6.

redundancy while minimizing waste since different nodes perform diverse functions within the system. As long as there is more than one of each type of element (sensor, weapon, communicator), the enemy is at a disadvantage because is difficult to disable the network with one shot. Even if the enemy destroyed one node, other nodes remain capable of exploiting engagement transients (e.g. active sonar, torpedo noise) and conducting a counterattack.

It is important to note that tailorable systems are not necessarily synonymous with highly distributed systems. The degree of distribution in the network is less significant than the separation of elements. Glider, for example, is a distributed network in which all critical elements are combined in each node (i.e. homogeneous). As modeled, this system can only be scaled, not tailored, to the mission at hand. In addition, highly distributed networks typically suffer in terms of cost and/or performance, so there is a point at which distribution begins to negatively impact cost-effectiveness. Further analysis is recommended to determine the exact relationship between system distribution, weapons capability (i.e. range, warhead size, etc.), and overall system utility.

Separation of elements, on the other hand, provides the tactical advantages of redundancy without sacrificing cost-effectiveness. AUWS need not be highly distributed for success. Some distribution is necessary for redundancy, but separation of elements is critical for gaining the tactical advantage.

7.2 Recommendations

Specific recommendations are broken down into near, middle, and far term categories to give decision makers a clear guideline for the development of Advanced Undersea Warfare Systems. Recommendations are based on insights gained from the analysis in its entirety and not just the ranking of system concepts.

7.2.1 Near Term

Steps that can be implemented now, within the context of Future Years Defense Program 2012-2016, include:

- Research organizations, such as NPS, should continue detailed analysis of V-CAP, LD-UUV, and similar AUWS concepts. The following specific areas of focus for further analysis are recommended.

- Implementation of Classified material, including specific threat and friendly capabilities, to ensure that analysis results accurately reflect the current situation.
 - Development of AUWS top level requirements, using the identified need areas as a basis.
 - Detailed analysis of autonomous command and control, including ways to improve threat discrimination and the effects of in-stride adjustable autonomy on overall mission accomplishment.
 - Detailed design of system and subsystem components. Concurrently, a detailed feasibility analysis should be conducted to determine the design tradespace required to realize projected operational concepts.
 - Refinement of the modeling and simulation effort, including a realistic, physics-based acoustic sensor input for distributed network performance.
 - Development of Life Cycle Cost Estimates, to include R&D, procurement, O&S, and disposal costs. The operational costs developed in this analysis should be used as a basis.
- The cost-effectiveness and high endurance of gliders warrant further investment in these vehicles for non-tactical missions, such as oceanography. Development of the AUWS Glider concept is not recommended until maneuverability can be sufficiently improved without sacrificing high endurance and low cost. Since Glider and LD-UUV share an equivalent overall utility, it is recommended that the Navy continue its pursuit of LD-UUVs for tactical purposes.
 - DoD (and DoN) should review and update doctrine related to USW, unmanned systems, and autonomous systems. Specifically, ROE should clarify the differences between unmanned and autonomous systems, and between traditional undersea weapons and AUWS. Since AUWS does not adequately fit into the conventional definition of a mine, torpedo, or submarine, new definitions for concepts based on emerging technology are necessary. The tactical publications and training manuals that govern how the Navy fights in the undersea battlespace should also be updated based on the concepts discussed in this analysis, from both an offensive and defensive perspective.

- ONR should use this analysis to aid in defining a specific Science and Technology Gap with respect to future USW and AUWS.
- ONR should assign a Future Naval Capabilities Manager to ensure AUWS concepts receive necessary R&D funding to meet middle term recommendations.
- To the greatest extent possible, prototypes of unmanned underwater systems should be included in fleet exercises. In order to improve operational concepts and, ultimately, mission effectiveness, sailors must be afforded the opportunity to interact with these systems at the operational and tactical levels. It is not important that such prototypes accurately resemble AUWS, since the underlying principles of operating unmanned and autonomous systems have wide applicability. Operators must become proficient in this unfamiliar dynamic in order to effectively wield future warfare systems.

7.2.2 Middle Term

In the intermediate time frame of FYDP 2016-2020, the following implementations should be considered:

- Based on this analysis and future analyses (including an S&T Gap Analysis), an Initial Capability Document should be developed to facilitate AUWS entry into the acquisition process.
- The ICD should form the basis of a Program of Record for the AUWS concept that provides the most utility to the Navy, given an updated assessment of the current capability gap.
- The Navy should not wait for technology to advance to optimal levels before making long term investments in AUWS or similar systems. Requirements, operational concepts, and tactics must lead the technology in the effort to maintain USW dominance in the future.

7.2.3 Far Term

Past the year 2020, it is difficult to predict the specific programmatic steps that will be required to ensure the United States Navy's dominance in USW. The uncertainty involved in projecting what the future will look like in ten years makes detailed far term recommendations almost irrelevant. Still, the root problem facing the platform-centric model for USW remains,

and the insights gained from this analysis can be used to build upon near and middle term recommendations. The Navy should maintain a goal of achieving full operational capability for AUWS by 2030, provided that future reassessments of the undersea battlespace validate the initial problem defined in this analysis.

8. Conclusion

The undersea battlespace of the future is a complex, dynamic environment that cannot be neatly divided along platform or community lines. Emerging technologies simultaneously enable and require the Navy to adopt new models for continued USW dominance. In the contested littoral waters where employment is likely, the Navy cannot accept the risk incurred by relying on multi-billion dollar assets to control the undersea battlespace, particularly when a wide range of potential adversaries have access to the same emerging technologies studied in this analysis. The Navy must posture itself, at all levels, to adapt to this new reality and exploit the opportunities generated.

Advanced Undersea Warfare Systems are just one element of a comprehensive, unified approach to maintaining and enhancing USW dominance in the future. By focusing on systems that are flexible, scalable, and tailorable, the Navy can balance the cost, risk, and required performance for the array of USW challenges it can expect to face in the future.

Ultimately, the objective of this analysis is to support decision makers as they begin to make major investments in systems such as AUWS. The true measure of success of any warfare system is its ability to address the needs of the warfighter, not the technology it comprises. Using the results and recommendations in this analysis, decision makers can more effectively harness emerging technology and thus drive its development toward systems built upon future warfighter needs in the undersea battlespace.

Appendix A: Initial Tasking Document

XXX

MEMORANDUM FOR SEA-17 and TDSI STUDENTS

Subj: 2011/SEA 17 CAPSTONE PROJECT OBJECTIVES

Enclosures: Tab A: Preliminary objectives: Regional Stability Project
Tab B: Preliminary objectives: Advanced Undersea Weapons Project

1. This memorandum provides guidance for the conduct of the integrated project which is required as partial fulfillment for your various degrees. You will deliver your completed project report and final briefing materials to the Project Advisor on or before 1 June 2011, in accordance with the following plan and milestones.
 - a. Develop a project proposal and a project management plan during the Fall Academic Quarter 2011. This proposal and plan will serve to focus your initial research and analysis. You should plan to review and update this plan frequently as you progress with your research.
 - b. Conduct project reviews approximately every six weeks, finishing with a final brief to be delivered to interested stakeholders on and off campus.
 - c. Begin outlining and preparing your Project Report as early as you can. Work with your faculty advisors, about every week, to prepare your Project Report for their approval and signature by 20 May 2011. The edited and processed final report is due on 1 June 2011.
2. There will be two projects and associated teams as part of the 2011 capstone experience. The preliminary objectives statements for the projects are contained in Tabs A and B. Your initial efforts should be to refine these objectives statements, based on research of current guidance documents and subject to the approval of your faculty advisors. Each of you will be assigned to one of the two projects.
3. You will be expected to identify and integrate students and faculty from across the campus -- and other resources from outside the school -- to participate directly in your project or to provide source documents, technical knowledge and insights, and knowledge of evolving requirements, capabilities, and systems. This participation could include students who would join your groups, students doing related individual thesis topics such as those from TDSI, faculty inside or outside NPS who have expertise related to your project, and appropriately engaged government agencies and industry developers. It will be your responsibility to integrate the efforts of outside participants in your projects. Your faculty advisors will, of course, assist in these efforts.
4. You should employ the systems engineering and analytical methodology you have been learning in your class work and from your advisors. The role of the SEA students in the campus-wide integrated project is that of the lead project systems engineering team, working

closely with other members of the project engineering team from TDSI and other campus curricula. SEA 17 students will be expected to define the functions and performances of your system, develop alternative architectures to meet those functions, and evaluate the alternative architectures for performance. In executing these tasks you will be defining and understanding the overall project requirements (recognizing that this definition process is iterative and will evolve as the project progresses). Other teams, consisting of TDSI and other students are to be integrated into the overall task and assigned specific project responsibilities, to be negotiated among you as necessary.

5. SEA 17, working closely with TDSI and other students, will have to define the selected concepts for supporting systems (the components in your systems) and partition the overall system requirements to be addressed by supporting teams of students and faculty. Your role will include providing central guidance and requirements clarification and resolution, working with supporting teams, and completing your tasks according to your schedule. The efforts of all participants will have to be integrated to form a coherent, cohesive, finished report of the overall project.
6. Background research is a major part of the task for the participants.
7. The grades assigned to the participants in these projects will be pass/fail, and will be assigned by the lead faculty advisor for each of the tasks. Although you will work as part of a team, your individual performance will be the basis for this evaluation. Successful completion and documentation of your project is a degree requirement. It would be unwise to assume that a grade of “pass” is automatic.

Prof. Charles Calvano
OPNAV SEA Chair

Distribution:

SEA-17 students; TDSI students; other cooperating students; faculty advisors
Profs Calvano, Shebalin, Hughes, Papoulias, Paulo, Mansager, Stevens, Solitario, Kline, Olwell, Dell, Harney, Langford, RADM Williams, RADM Ellis, President Oliver, Provost Ferrari, Dean Sritharan, Dean Purdue, CDR Burton

Tab B – Team B

Advanced Undersea Weapons and Mine Warfare

Mines have been used or encountered by the US Navy in nearly every maritime conflict in our nation's history. In recent times, mines have often been the asymmetric weapon of choice for nations with less capable navies, rogue states or terrorists who have sought to limit or harass the execution of US naval missions by the use or threatened use of naval mines, but mines still have the potential for significant use by near-peer competitor navies.

It is clear that the miner has a distinct advantage. Development and construction of naval mines can be accomplished quickly and relatively inexpensively. Applications of current technology to naval mine development can further complicate countering naval mines. Additionally, a variety of naval mines, some that are quite sophisticated, are available for purchase on the open market. Consequently, the range and variety of mines that may be encountered create the requirement for a complex and probably expensive approach to countering these threats.

During recent discussions with the Chief of Naval Operations, the Commander Naval Mine and ASW Command has suggested that the United States Navy should consider the development of Advanced Underwater Weapons Systems (AUWS). Rather than maintaining the obsolescent capability of current mine inventories and the warfare capability historically provided by static mine fields, the US Navy should work to harness the emerging technologies that can be found in underwater sensors, networks, undersea weapons, and unmanned vehicles to build an enhanced capability for undersea warfare dominance. Not only would such an approach provide a more comprehensive answer to both offensive and defensive undersea warfare, but such an approach should also create added pressure on any potential antagonist to expend resources to counter this approach.

Team B is tasked to “Define a system of capabilities that would be necessary to create and sustain an underwater operational picture of areas of interest and counter and engage adversary manned and unmanned systems when required.” Your system should be a deployable asset (either a permanent system for some areas and / or a temporarily deployable and recoverable system for other uses) by the 2025 time frame and should support the goal of shaping the underwater battlefield and denying areas to an adversary. You should consider currently existing systems and ongoing research as a starting point. Your work should address Planning, Programming, Budgeting, and Execution (PPBE) and Technology Readiness Levels (TRL) considerations where appropriate. Your alternatives should include low-cost and near-term options as well as options based on sophisticated technology.

A related task that would share many technological aspects with the above task is included. (This should be the work of a sub-team):

Develop a Joint System of Systems concept and supporting architecture that supports the development and operations of a smart undersea weapon that whose primary mission is to protect

a ship at sea and in port. The smart undersea weapon is not controlled by the ship which is being protected. Consider current and evolving unmanned technologies to design solutions that take into account advanced concepts of underwater, surface, and air defense that would be packaged into the smart undersea weapon. Consider operations, command and control, autonomous operations, mine warfare and all aspects of Undersea Warfare.

Advisors: Prof. Gary Langford, SE faculty lead; RADM Rick Williams, Subject Matter Expert

Appendix B: SEA-17B Capstone Project Survey Questionnaire

Date: _____

To: _____

From: _____

Subj: SEA-17B Capstone Project Survey Questionnaire

Dear Sir/Ma'am,

My name is _____, USN and I am a Systems Engineering Analysis (SEA) student at the Naval Postgraduate School (NPS) in Monterey, CA. We have been tasked with developing an Advanced Underwater Weapons System (AUWS) to fulfill the requirements of our Capstone Project, the final event in our Master's degree program.

The AUWS will provide advanced offensive and defensive Mine Warfare (MIW), Anti-Submarine Warfare (ASW), and Surface Warfare (SUW) systems with organic sensing and communications capability for network-centric operations. The AUWS is aimed at providing a low-cost, rapidly deployable system of systems (SoS) solution beyond the existing Littoral Combat Ship (LCS) paradigm.

To properly craft this system, we must use a Systems Engineering Approach founded on a formal Stakeholder Analysis. You have been selected as one of the many people who hold an interest in a project such as ours. Flag, Senior, and Commanding Officers in the USN warfare disciplines as well as DoD researchers, contractors, and analysts are all valuable resources for crafting a robust and accurate portrait of the capability gap we must fill.

We would greatly appreciate your taking the time to answer the following questions:

- Where do you see MIW in the future of USN operations?
- Where do you see ASW in the future of USN operations?
- Where do you see SUW in the future of USN operations?
- Do you see a need for Unmanned Vehicles in USN operations? If so, what kind of vehicles do you envision, and with what capabilities should these units be equipped?
- Based on your experience, do you feel like this AUWS is a necessary aspect of future USN operations?
- Beyond the brief description above, what facets of USN operations should be included, excluded, stressed, or de-emphasized?

- Do you know of any existing systems that address some or all aspects intended for address by the AUWS?
- What gaps exist in the current USN Battle Fleet's capability, to include weaponry, sensors, material, and assets?
- If you were going to spend a dollar on AUWS, what aspect, function, or capability would you spend it on? Would you prefer to spend your dollar on a non-material solution (i.e. training)?
- What requirements would you, as a stakeholder in the military-industrial complex, have for a system such as AUWS?
- What parameters and metrics are important to you in the measurement of performance of a system such as AUWS?
- What additional comments or advice do you have for our team with regard to AUWS?

Thank you very much for your time. We will include your responses in our research for use in building our stakeholder analysis, and ultimately, our list of requirements. If you should need or want to contact us, we can be reached at SEA17B@nps.edu.

Very Respectfully,

SEA-17B, Naval Postgraduate School

Appendix C: MOEs and MOPs

The following is a list of all MOEs and MOPs considered for analysis in AUWS. For the sake of simplicity, only a select few are thoroughly modeled and analyzed. It is recommended that future analysis on AUWS use this list as a conceptual foundation.

Power

- Distribution (Endurance)
 - MOE: Capability to Operate for Minimum of 30 Days
 - MOP: Average Time Inactive (days)
 - MOP: Average Time Conducting Loiter (days)
 - MOP: Average Time Conducting Patrol (days)
 - MOP: Average Time Conducting Sprint (hours)
 - MOP: Proportion of Power Required for Mission Profile
 - MOP: Rate of Component Efficiency/Power Draw
 - MOP: Average Energy Production from Fuel
 - MOP: Rate of Fuel Consumption (gallons/hr)
 - MOP: Average System Efficiency (%)
 - MOP: Average Electrical Power Requirement
- Generation
 - MOE: Capability to Recharge
 - MOP: Rate of (Re)Charge(Ah)
 - MOP: Average Time System Unavailable
- Storage
 - MOE: Capability to Store Energy
 - MOP: Average Capacity of Battery (Ah)
 - MOP: Rate of Discharge (Ah)

C3

- Command
 - MOE: Probability of Successful Command Automation
 - MOP: Average Time to Process Data Sets Correctly
 - The average elapsed time from the start of the entry of data sets to the correct completion of multiple tasks.
 - MOP: Average Time to Correctly Process Retrieved Data Sets
 - The average elapsed time from the completion of receiving data sets from local data bases to the correct completion of multiple tasks.
 - MOP: Average Time to Correctly Process Transmitted Data Sets
 - The average elapsed time from the completion of the receipt of data sets from remote sites or the completion of retrieval of data sets from the local data bases to the time of correct processing of data sets.
 - MOP: Average Time to Successively Transmit Data Set

- The average elapsed time from start to successful completion of the transmission of data sets.
 - MOP: Average Time to Successfully Retrieve Data Sets
 - The average elapsed time from start to successful completion of the retrieval of data sets.
 - MOP: Reliability of Network File Transfer
 - MOP: Proportion of Data Sets Processed Correctly
 - The ratio of the total number of data sets processed correctly to the total number of data sets entered for multiple tasks.
 - MOP: Average Report Generation Time
 - MOP: Utility of Communication Interface
 - MOP: Average Time to Correctly Process Retrieved Data Elements
 - The average elapsed time from completion of retrieving data elements from the local site to the successful completion of processing to the total number of data elements processed.
 - MOP: Average Time to Process Data Elements Correctly
 - The average elapsed time from start of entry of data elements to the completion of processing to the total number of data elements processed.
 - MOP: Average Time to Correctly Process Transmitted Data Elements
- Autonomous Control
 - MOE: Probability of designating the appropriate level of autonomy prior to deployment
 - MOE: Capability to Vary (Change) Level of Autonomy
- Communicate
 - MOE: Capability to Communicate
 - MOP: Average Time to Establish Communications
 - MOP: Call Completion Rate (CCR)
 - MOP: Average Signal Range
 - MOP: Average File Transfer Time over the Network
 - MOP: Average Data Rate
 - MOE: Capability to Receive Message
 - MOP: Message Completion Rate (MCR)
 - MOP: Average Time to Acknowledge Report
 - MOP: Message Accuracy
 - MOE: Capability to Transmit Message
 - MOP: Average Data Message Completion Time (MCT)
 - MOP: Average Transmission Backlog
 - MOP: Average Duration of Transmission Wait

ISR

- Search
 - MOE: Capability to Search for Target
 - MOP: Search Rate

- MOE: Probability of Location Accuracy
 - MOP: Average Range Error
- Detect
 - MOE: Probability of Correct Target Detection Identification
 - MOP: Reasons for No Detection
 - MOP: Proportion of Detections
 - MOP: Average Range of Detection
 - MOP: Average Time from Target Presentation to Detection
 - MOP: Average Target Presentation Range
 - MOE: Probability of Correct Target Recognition Identification
 - MOP: Reasons for Incorrect or No Recognition
 - MOP: Time from Detection to Recognition
 - MOP: Proportion of Correct Recognitions
 - MOP: Proportion of Recognitions versus Classifications
 - MOP: Average Range of Recognition
 - MOP: Average Time from Target Classification to Recognition
 - MOP: Proportion of Identifications versus Recognitions
 - MOP: Average Time from Target Recognition to Identification
 - MOP: Average Range of Identification
 - MOP: Proportion of Time Fratricides Avoided
 - MOP: Reasons for Incorrect or No Identification
- Track
 - MOE: Probability of Correct Target Prioritization
 - MOP: Time from Classification to Prioritization
 - MOP: Reasons for Incorrect or No Prioritization
 - MOP: Average Range of Prioritization
 - MOP: Proportion of Manual Overrides to Automatic Prioritization
 - MOP: Average Time from Identification to Prioritization
 - MOP: Target Prioritization Rate
 - MOE: Capability to Track Target
 - MOP: Average Distance between Uncorrelated Tracks
 - The average distance between different sensor tracks when correlation between sensors failed.
 - MOP: Proportion of Formations Resolved
 - The ratio of the total number of formations resolved by the sensor to the total number of formations presented.
 - MOP: Average Tracking Error
 - The average error between the sensor tracked location and the matched actual target location.
 - MOP: Proportion of Track Correlation

- The ratio of time when correlation did occur to the total possible time where correlation could have occurred.
 - MOP: Proportion of Time Tracking Lost
 - The sum of the intervals between each track drop and the next detect per time of possible tracking.
 - MOP: Proportion of Time Tracked
 - The ratio of the total time a target is tracked by a sensor to the total possible target tracking time
 - MOP: False Track Sources
 - The number, by category, of the sources of false tracks.
 - MOP: False Track Rate
 - The ratio of the total number of false tracks to the time of possible tracking.
 - MOP: False Track Rate on Transmitted Cues
 - The ratio of the number of transmitted cues on false tracks to the time of possible tracking.
 - MOP: Reasons for Not Tracking
 - The reasons, by category, for not tracking a target.
 - MOP: Ratio of Track Duration Times
 - The ratio of the sum of the duration times of each track and track segment per time of possible tracking.
 - MOP: Average Range at Formation Resolution
 - The average distance of the sensor from the formation when the formation is resolved.
 - MOP: Track Drop Rate
 - The number of track drops per total time of possible tracking.
- Classify
 - MOE: Probability of Correct Target Classification
 - MOP: Proportion of Correct Classifications
 - MOP: Reasons for Incorrect or No Classification
 - MOP: Average Range of Classification
 - MOP: Average Elapsed Time from Target Detection to Classification
 - MOP: Proportion of Correct Classification Records
 - The ratio of the total number of target records containing correct classification(s) to the total number of target records.
 - MOP: Proportion of Classifications versus Detections
 - MOP: Time from Identification to Classification
- Collect Intelligence
 - MOE: Capability to Integrate Information from Various Sensor Sources and Consolidate Redundant Contacts into a Single Track
 - MOE: Capability to Develop Situational Intelligence
 - MOP: Average Time to Generate ISR Report
 - MOP: Proportion of Targets Reported

- MOP: Average Time to Release ISR Report

Prosecute

- Deter
 - MOE: Probability of Successful Employment of Decoy
 - MOE: Probability Threat Retreats
- Engage
 - MOE: Probability of Successful Engagement
 - MOP: Number of Successful Engagements on the first day Threat present
 - MOP: Average Range of Engagement
 - MOP: Proportion of Fire Missions Completed
 - MOP: Reasons for No Engagement
 - MOP: Capability to engage in sea state 3
 - MOE: Probability of Timeliness
 - MOP: Average Time from Target Engagement to Hit
 - MOP: Average Time From Target Presentation to Hit
 - MOP: Engagement Rate
 - MOP: Hit Rate
 - MOP: Kill Rate
 - MOP: Average Fire Mission Processing Time
 - MOP: Average Time from Target Acquisition to Engagement
 - MOP: Average Kill Range
 - MOP: Average Target Handoff Time
 - MOE: Probability of Accuracy
 - MOP: Proportion of Rounds Meeting Stated Accuracy
 - MOP: Average Round Error
 - MOP: Reasons for No Hit
 - MOP: Proportion of Hits vs Engagements
 - MOE: Probability of Effectiveness
 - MOP: Proportion of Target Engagements vs Acquisitions
 - MOP: Average Hit Range
 - MOP: Average Burst Radius
 - MOP: Reasons for No Kill
 - MOP: Loss Exchange Ratio
 - MOP: Proportion of Target Kills vs Engagements
 - MOP: System Exchange Ratio
 - MOP: Force Exchange Ratio

OPSEC

- Detection
 - MOE: Probability of Detection Avoidance

- MOP: Detection Avoidance Proportion
- MOP: Detection Survivability Ratio
- MOP: Average Exposure Time
- MOP: Average Dimensions of Radar Cross Section of the System (Meters²)
- MOP: Average Threshold Levels of Infrared Emission (Kelvin/Exitance/Wavelength or Watts/Steradian)
- MOP: Average Threshold Levels of RF Emission (Watts)
- MOP: Average Threshold Levels of Contrast Reflectance (luminance, chromaticity, and visual texture measured in percentage)
- MOP: Average Threshold Levels of Acoustic Emission ((dB/Hz relative to 1Pa at 1m))
- MOP: Average Dimensions of Laser Cross Section (Meters²)
- MOP: Average Threshold Levels Magnetic Anomalies (Amps/Meter or ratio against Earth's magnetic strength)
- MOE: Probability of being detected during deployment/recovery
- Compromise
 - MOE: Capability to self-neutralize
 - MOP: Average Time to Execute Self-neutralization procedures
 - MOE: Probability of Surviving Detection
 - MOP: Acquisition Survivability Ratio
 - MOP: Hit Survivability Ratio

Maneuver

- Deploy
 - MOE: Probability of Surviving Deployment
 - MOP: Proportion of Deployment within Required Time
 - MOP: Average Setup Time: The average elapsed time to set up the system
 - MOP: Average Time to Deploy
 - MOP: Displacement
 - MOP: Average Displacement Time
 - MOP: Proportion of Displacements within Required Time
 - MOE: Capability for Deployment by both Contemporary and Future Platforms
 - MOP: Proportion of System Compatibility with Existing Platforms, Systems and Subsystems
 - MOE: Capability for Rapid Deployment
 - MOP: Average Time to Deploy
 - MOE: Capability for Mass Deployment
 - MOP: Average (or Max) square mileage covered by AUWS units per deploying platform
 - MOP: Average Standoff Range of Deploying Unit
- Patrol
 - MOE: Capability to Maneuver

- MOP: Rate of Speed
 - MOP: Average Speed for Conditions
- Recover
 - MOE: Probability of Surviving Recovery
 - MOP: Average Disassembly Time
 - The average elapsed time to breakdown the system
 - MOP: Average time to conduct battle-damage repairs ‘in situ’ for fast re-launch and reusability
 - MOP: Average Time to Recover
 - MOE: Capability for Rapid Recovery
 - MOP: Average Time to Recover
 - MOE: Capability for Autonomous or Semi-autonomous Recovery
 - MOE: Probability of Immediate Reusability after Recovery
 - MOP: Average Time System Unavailable
 - MOE: Capability for Rapid Battle-Damage Reparability
 - MOP: Average Time to Repair
 - MOP: Proportion of Repairs Conducted on Site
 - MOE: Capability for Recovery by both Contemporary and Future Platforms
 - MOP: Proportion of System Interoperability with Existing Platforms, Systems and Subsystems
- Navigate
 - MOE: Capability to Navigate Successfully
 - MOP: Average Height Terrain Profiling Radar Used
 - MOP: Proportion of Detected Obstacles
 - MOP: Average Maneuver Error
 - MOP: Average Location Error
 - MOP: Proportion of Navigation Equipment Usage
 - MOP: Average Error for Self-location

Provide Structure

- MOE: Capability to house physical elements for each function without adversely affecting performance of other functions
- MOE: Capability to integrate physical elements

Appendix D: Functional Analysis Diagrams

1. Functional Flow Block Diagrams

1.1 Provide Structure

Not applicable.

1.2 Provide Power

From Figure D.1, Provide Power consists of a loop function denoting the continuous cycle of the overall process. Within the loop, functional flow starts at Receive Power (Function 1.2.1), continues to Store Power (Function 1.2.2), then proceeds to Manage Power (Function 1.2.3) before reaching an AND branch, denoting that Distribution (Function 1.2.4) and Generation (Function 1.2.5) must occur before completing the process.

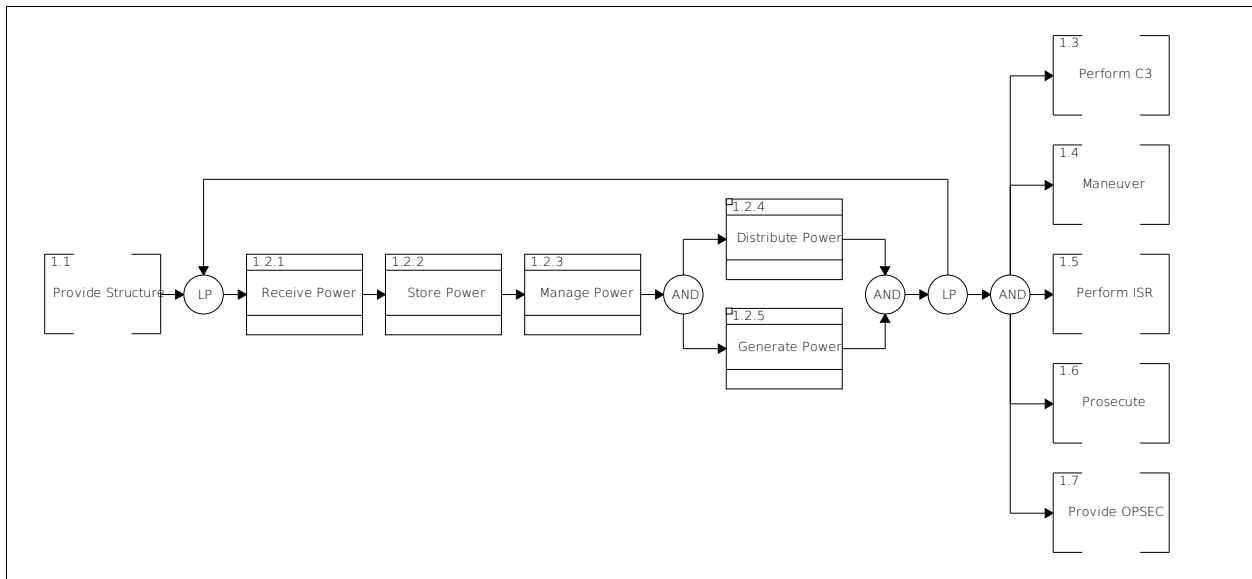

Figure D.1: Provide Power FFBD

Figure D.2 shows the functional flow internal to Distribution (Function 1.2.4.) Here, the allocation of power will either change (Function 1.2.4.1) or stay the same (Function 1.2.4.2).

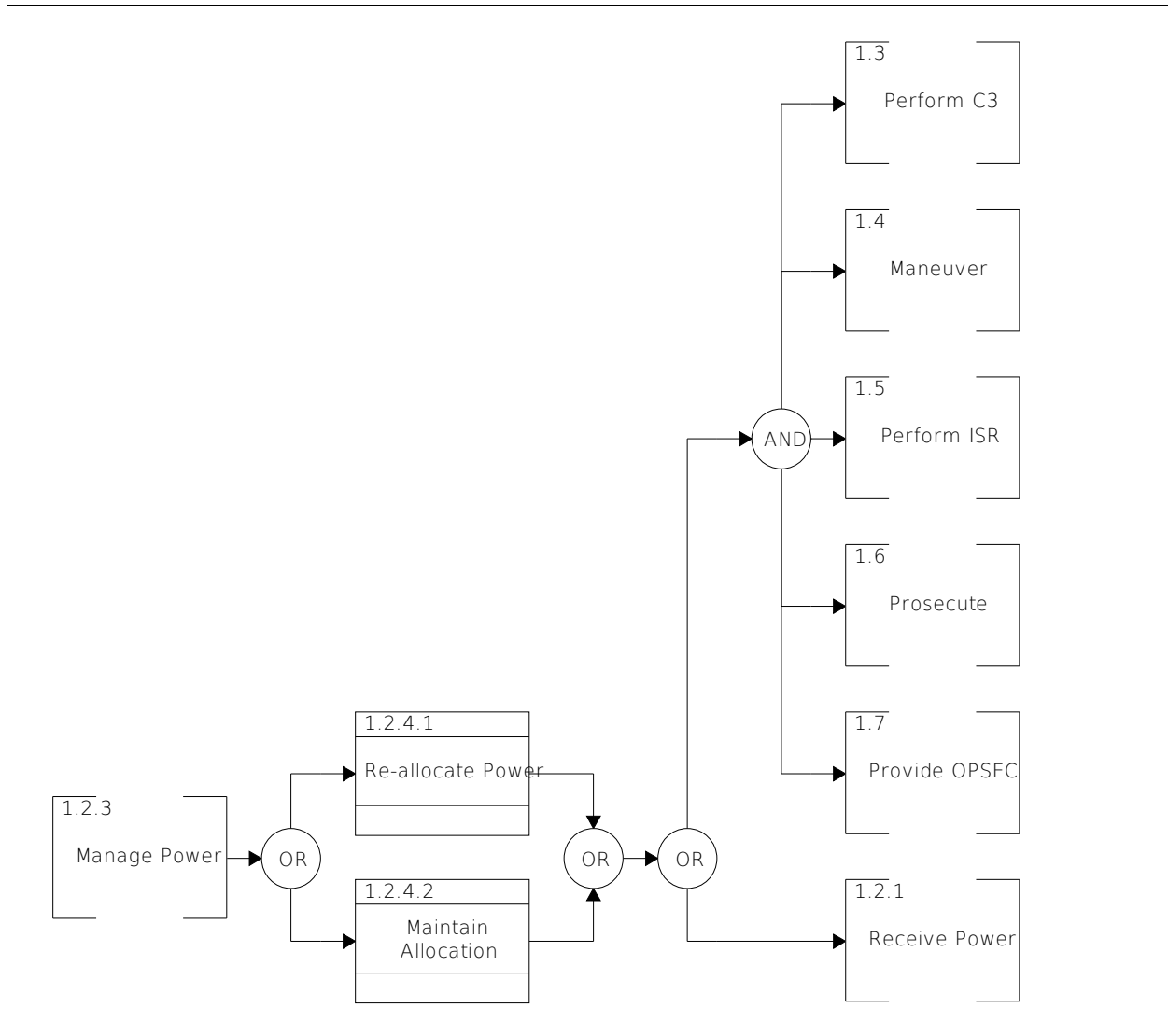

Figure D.2: Distribute Power FFBD

Figure D.3 shows a similar process occurring within Generate Power (Function 1.2.5). The system must either Conduct a Recharge (Function 1.2.5.1) and provide new power for use or storage, or Omit the Recharge (Function 1.2.5.2), depending on capability and feasibility.

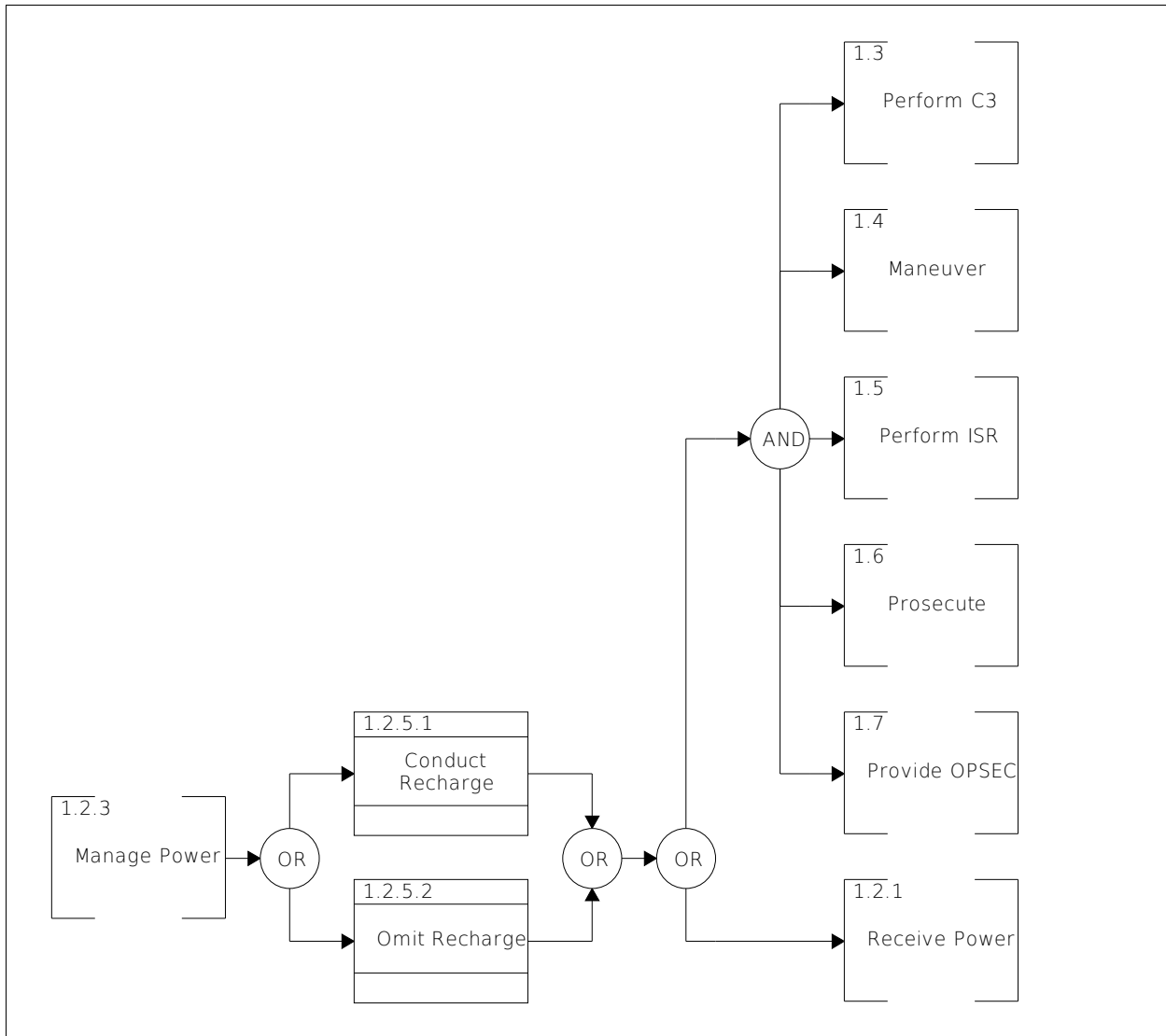

Figure D.3: Generate Power FFBD

1.3 Perform C3

Viewing the Perform C3 function as a one level FFBD in Figure D.4, it is apparent that Command (Function 1.3.1), Control (1.3.2) and Communicate (1.3.3) must occur simultaneously to complete the process.

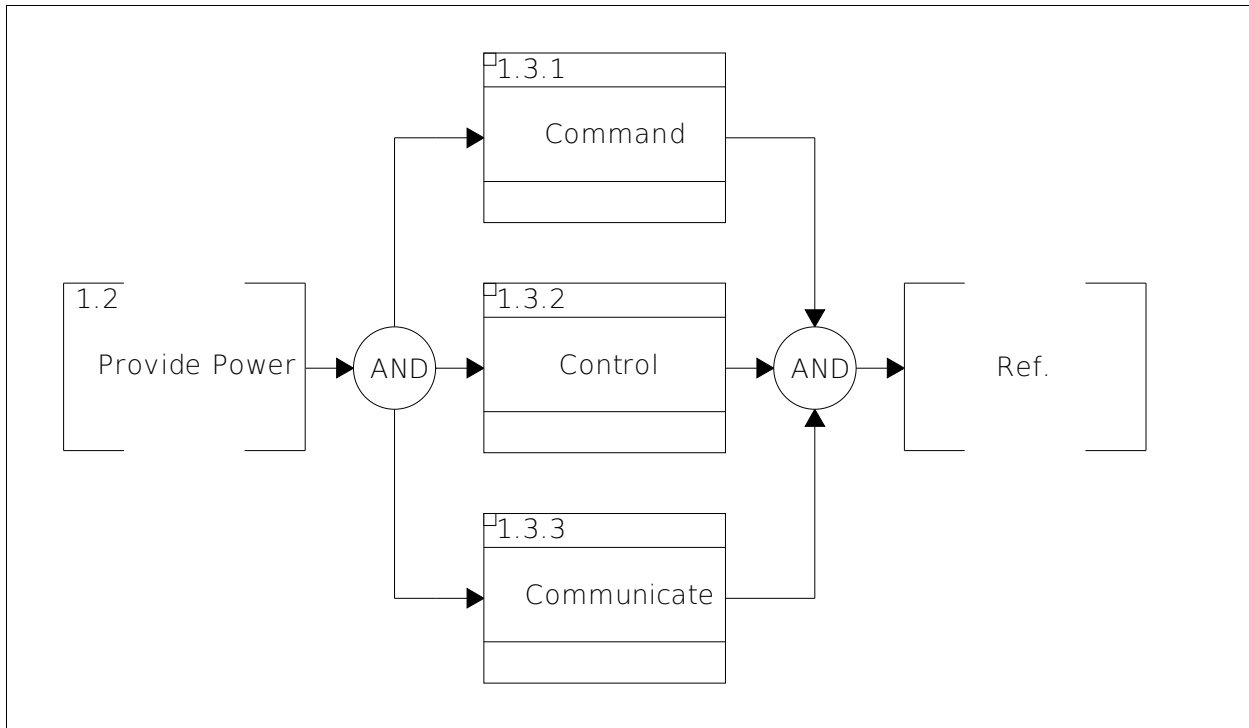

Figure D.4: Perform C3 FFBD

Figure D.5 shows the Command function FFBD. This function also works in a loop, starting with the simultaneous receipt of Orders (Function 1.3.1.1), Processing of Status (1.3.1.2), and Processing of ISR Data (1.3.1.3) for the sake of incorporating all inputs to the command module for attempting Analysis (Function 1.3.1.4) and ultimately, Execution of that Order (Function 1.3.1.5) before entering the next iteration. In this way, an OODA (*observe, orient, decide, act*) loop is created.

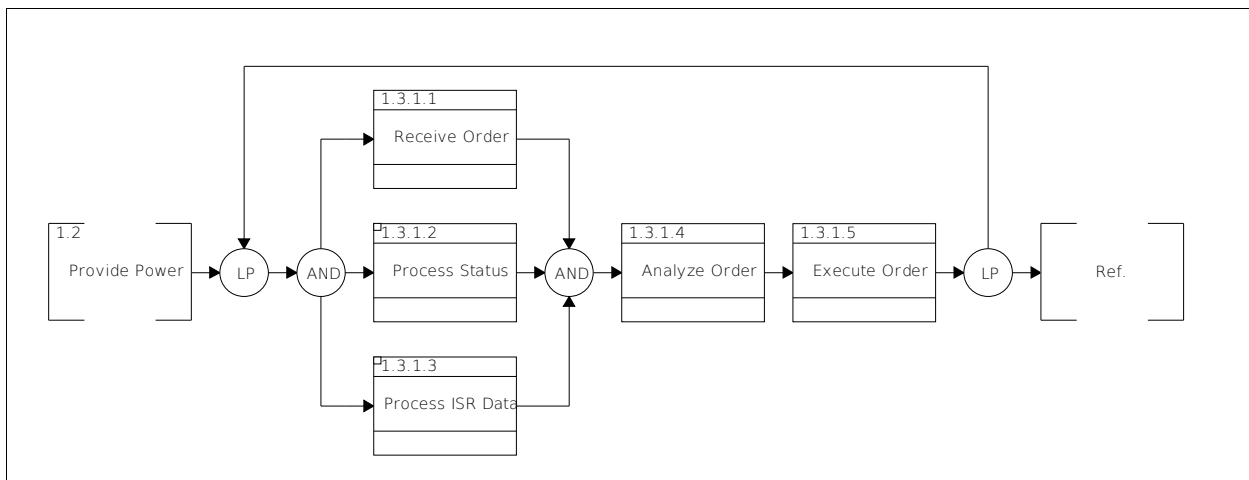

Figure D.5: Command FFBD

Figure D.6 shows the functional flow occurring within Process Status (Function 1.3.1.2). This linear process starts with the receipt of Component Status (Function 1.3.1.2.1), which is then Analyzed (Function 1.3.1.2.2) and fused to create an overall System Status (Function 1.3.1.2.3).

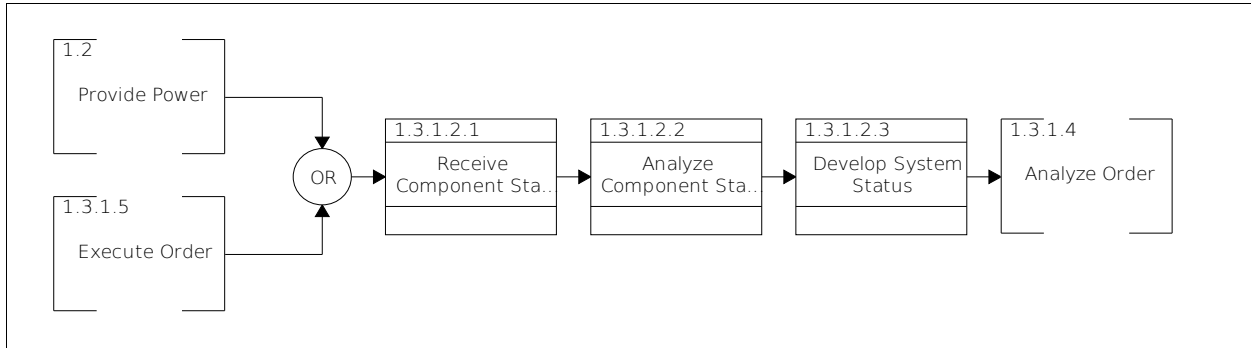

Figure D.6: Process Status FFBD

Figure D.7 shows the internal functional flow for Process ISR Data (Function 1.3.1.3). This linear process starts with the receipt of ISR data (Function 1.3.1.3.1) which is then Analyzed (Function 1.3.1.3.2) to concurrently produce Environmental Status (Function 1.3.1.3.3) and a Tactical Picture (Function 1.3.1.3.4) for the Operational Area.

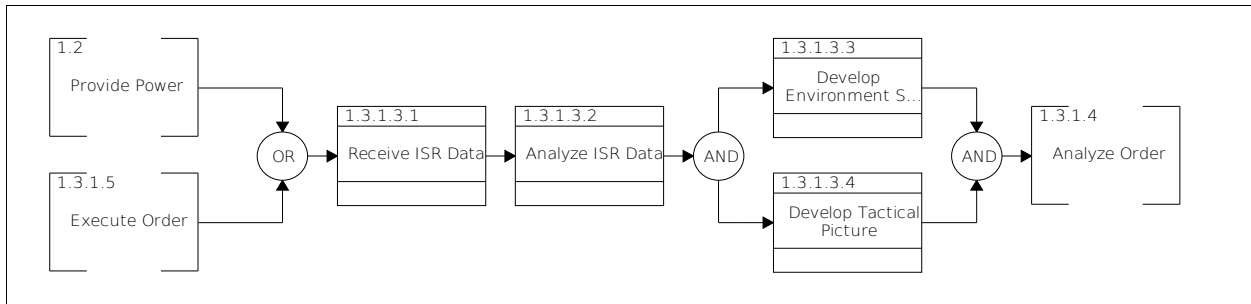

Figure D.7: Process ISR Data FFBD

Figure D.8 is the FFBD for the Control Function (Function 1.3.2). This one-level diagram uses OR logic to denote that only one mode of operation can be used at any given time, be it Fully Autonomously (Function 1.3.2.1), Semi-Autonomously (Function 1.3.2.2), or via Remote Control (Function 1.3.2.3).

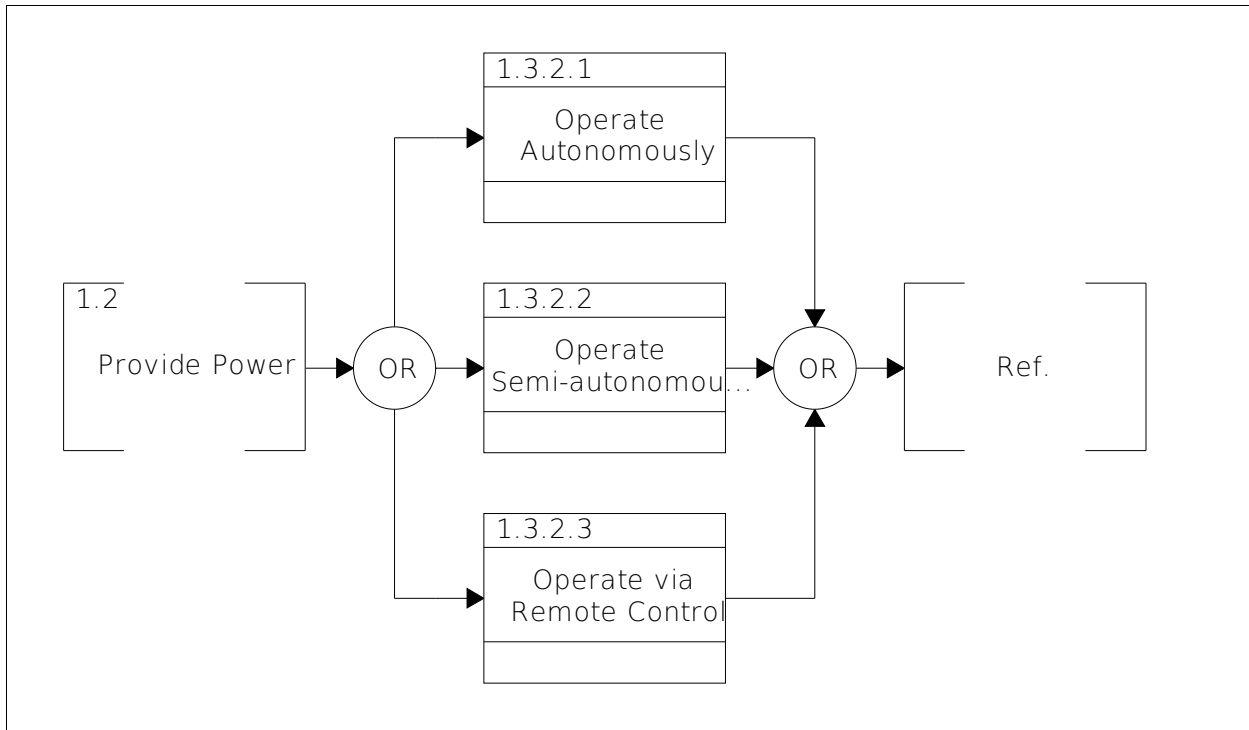

Figure D.8: Control FFBD

Figure D.9 is the FFBD for Control (Function 1.3.3). This iterative function describes a situation where data is both Received (Function 1.3.3.1) and Distributed (Function 1.3.3.2) or transmitted either Externally (Function 1.3.3.3) or Internally (Function 1.3.3.4). The loop closes, indicating that the process is continuous throughout AUWS operation as data is sent and received.

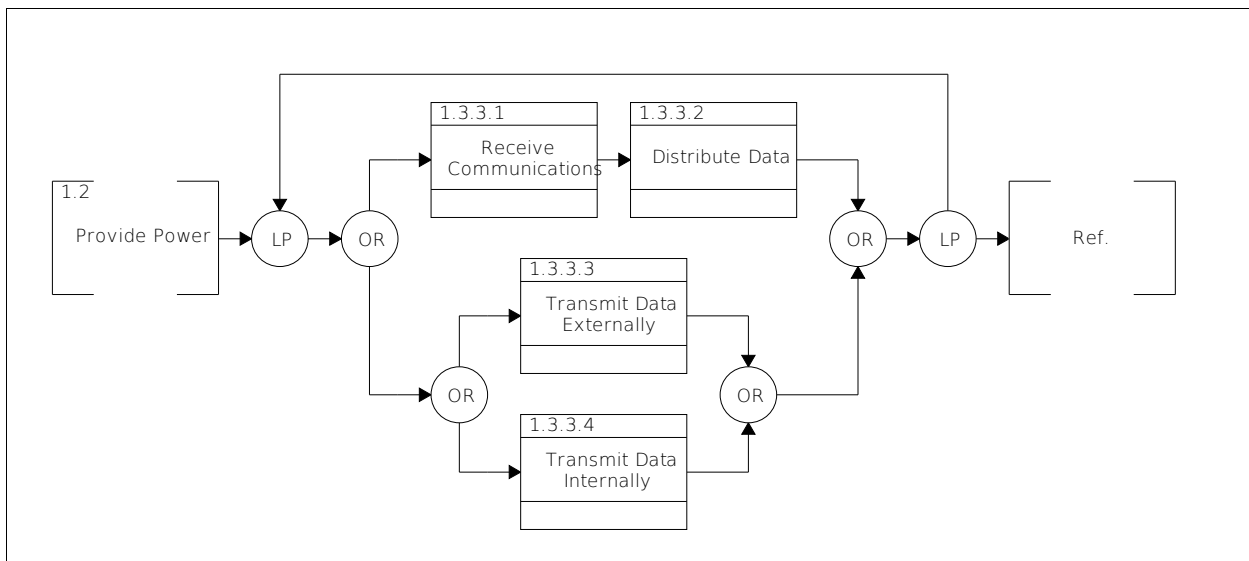

Figure D.9: Communicate FFBD

1.4 Maneuver

Maneuver's FFBD is depicted in Figure D.10. AUWS is deployed (Function 1.4.1), then simultaneously Patrols (Function 1.4.2) and Navigates (Function 1.4.3) before proceeding to the Recovery phase (Function 1.4.4).

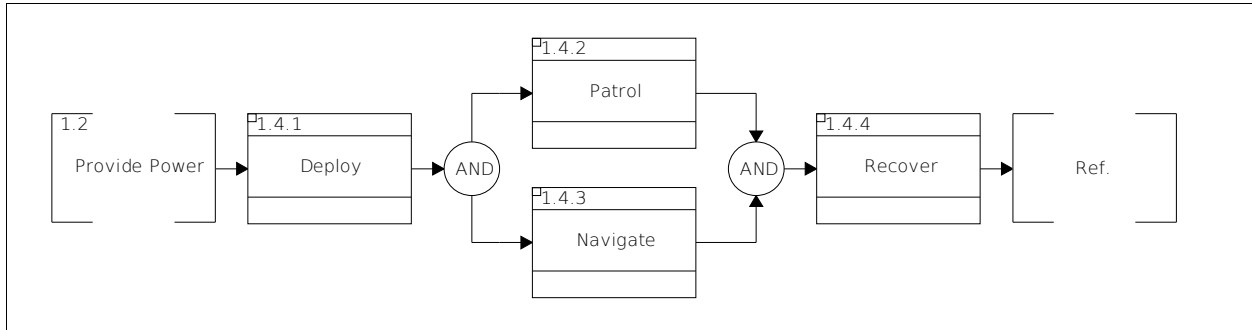

Figure D.10: Maneuver FFBD

Figure D.11 breaks Deploy (Function 1.4.1) into four possible methods: Submerged (Function 1.4.1.1), Surfaced (Function 1.4.1.2), Airborne (Function 1.4.1.3) and Shore (Function 1.4.1.4). Since a single unit on mission can only be deployed by one method each time (despite the fact that multiple AUWS units may be introduced to an area in a multi-platform operation) it follows that OR logic is best suited to the situation.

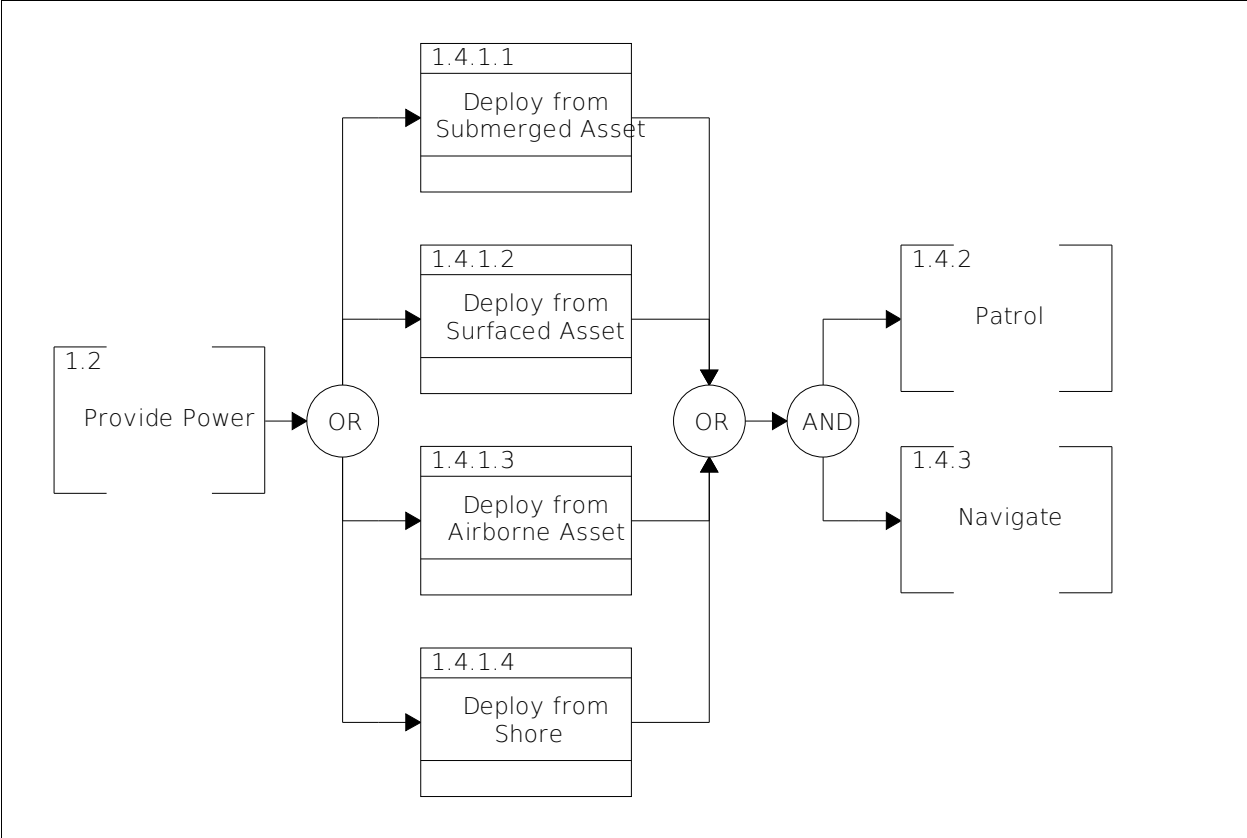

Figure D.11: Deploy FFBD

Figure D.12 is the FFBD for Patrol (Function 1.4.2). Another OR loop, this function shows that AUWS will either Loiter (Function 1.4.2.1), Rove (Function 1.4.2.2), Sprint (1.4.2.3) or Transit (Function 1.4.2.4) if needed. This OR function is nested with a loop, indicating that the operations will be performed in sequence as required before completing the function. For example, an AUWS unit might transit to an area, loiter as needed, and then sprint to a target for prosecution.

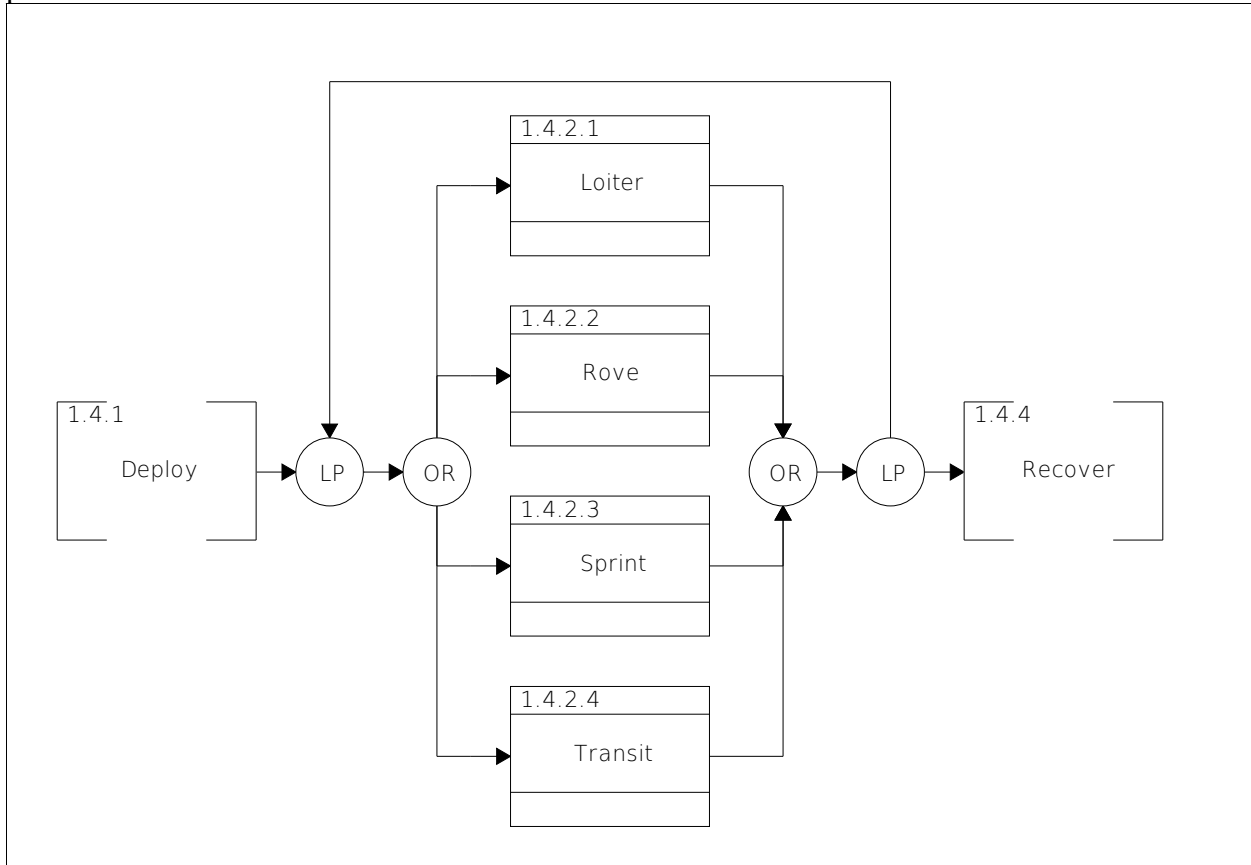

Figure D.12: Patrol FFBD

Figure D.13 is the FFBD for Navigate (Function 1.4.3). Location is Established (Function 1.4.3.1) first to determine system response to conduct Patrol (Function 1.4.2) operations. The functional flow proceeds to an AND branch where Propulsion (Function 1.4.3.2) and Steering (Function 1.4.3.3) are simultaneously employed to move AUWS. The loop then returns to the start of the process due to the feedback loop required between self-location and system response. When this loop has been performed enough times to meet all variations of the Patrol (Function 1.4.2) loop, the functional flow for Maneuver (Function 1.4) may continue to the final phase: Recovery (Function 1.4.4).

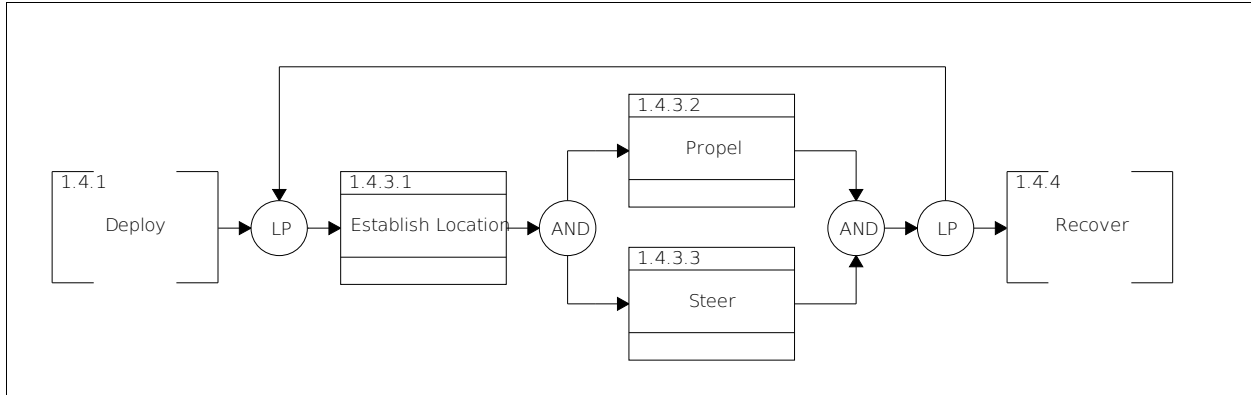

Figure D.13: Navigate FFBD

The Recover function (Function 1.4.4) is shown in Figure D.14. Like Deployment (Function 1.4.1), this is an OR logic branch with no iteration. AUWS must be recovered via Submerged (Function 1.4.4.1) or Surface (Function 1.4.4.2) asset or Scuttled (Function 1.4.4.3).

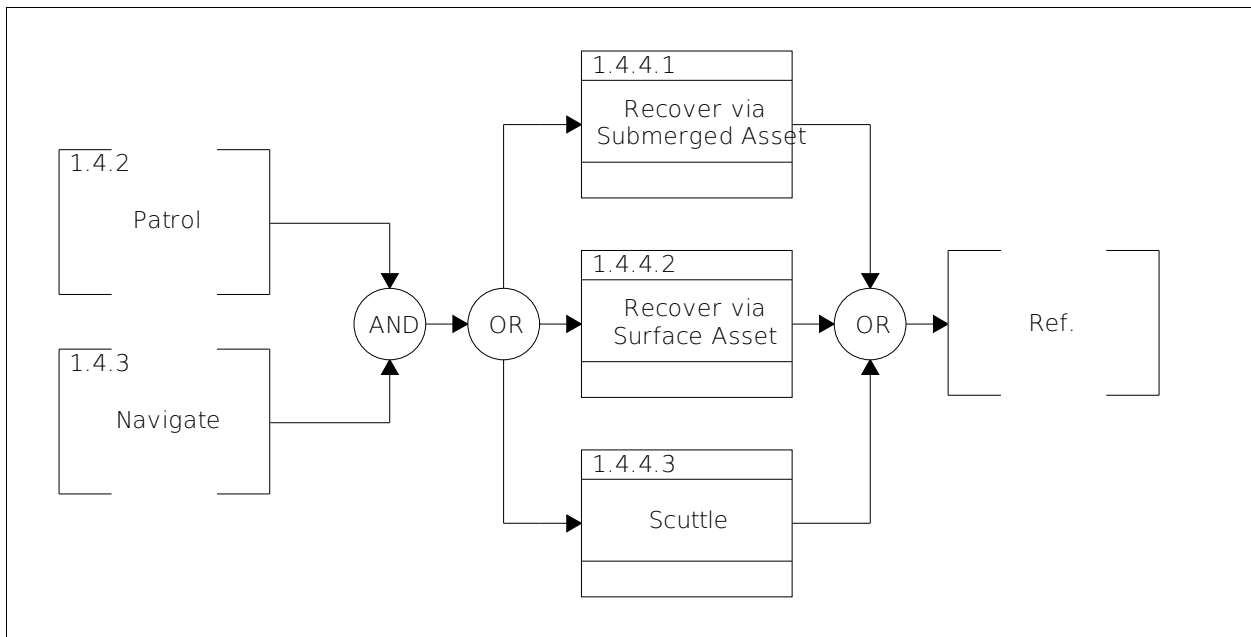

Figure D.14: Recover FFBD

1.5 Perform ISR

The FFBD for ISR Performance (Function 1.5) is shown in Figure D.15. An AND denotes the performance of tactical and intelligence collection using installed sensor suites. The top branch is a nested loop function proceeding from Search (Function 1.5.1) to Detect (Function 1.5.2) to Track (Function 1.5.3) to Classify (Function 1.5.4) before closing the loop, showing the continuous search for target signatures and the ensuing process of establishing tracks and classifying all detections in the sensor sweep area. The bottom branch shows Intelligence Collection (Function 1.5.5) nested within another loop, denoting a second continuous process.

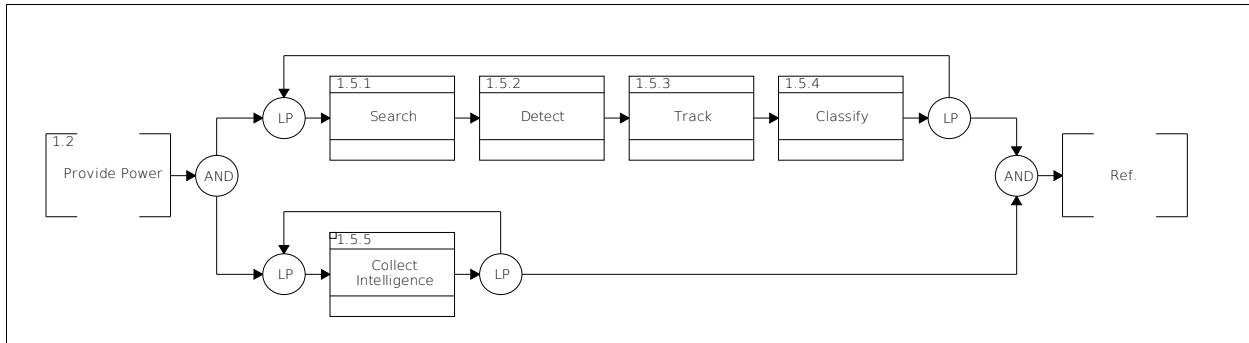

Figure D.15: Perform ISR FFBD

Figure D.16 expands the functional flow within Collect Intelligence (Function 1.5.5). ACINT (Function 1.5.5.1), COMINT (Function 1.5.5.2), SIGINT (Function 1.5.5.3), ELINT (Function 1.5.5.4) or EO/IR Data (Function 1.5.5.4) is collected as allowed by circumstances and readiness status. While no loop is shown within the function, it must be noted that the overall function exists within a loop one level up (Function 1.5).

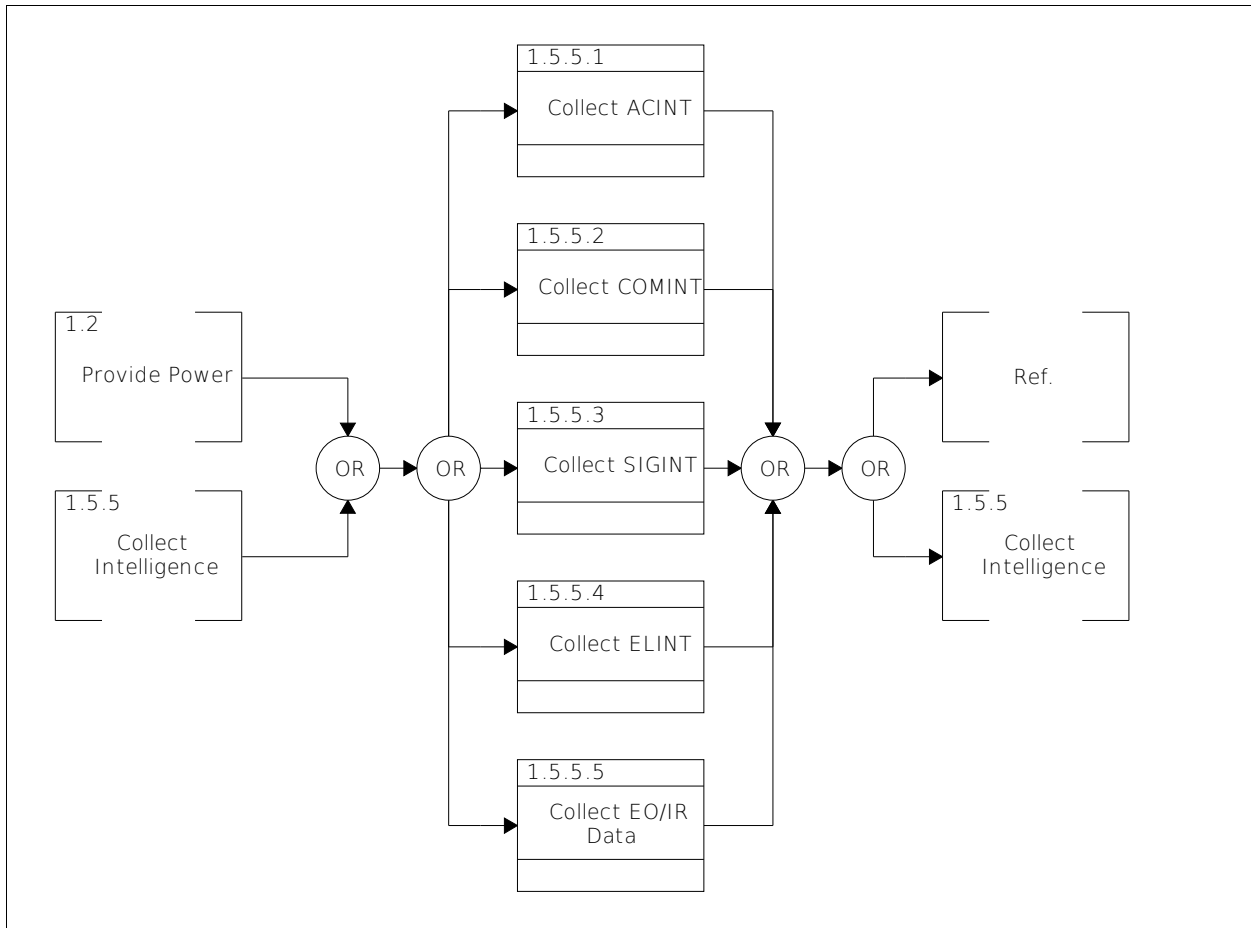

Figure D.16: Collect Intelligence FFBD

1.6 Prosecute

Figure D.17 shows the FFBD for Prosecute (Function 1.6). The OR loop dictates that AUWS, when given the order to Prosecute, will either Monitor (Function 1.6.1), Deter (Function 1.6.2), or Engage (Function 1.6.3), as directed. The OR branch is nested in a loop to indicate that while AUWS can only do one function at a time, it will continue to iterate until given further guidance, either externally or internally.

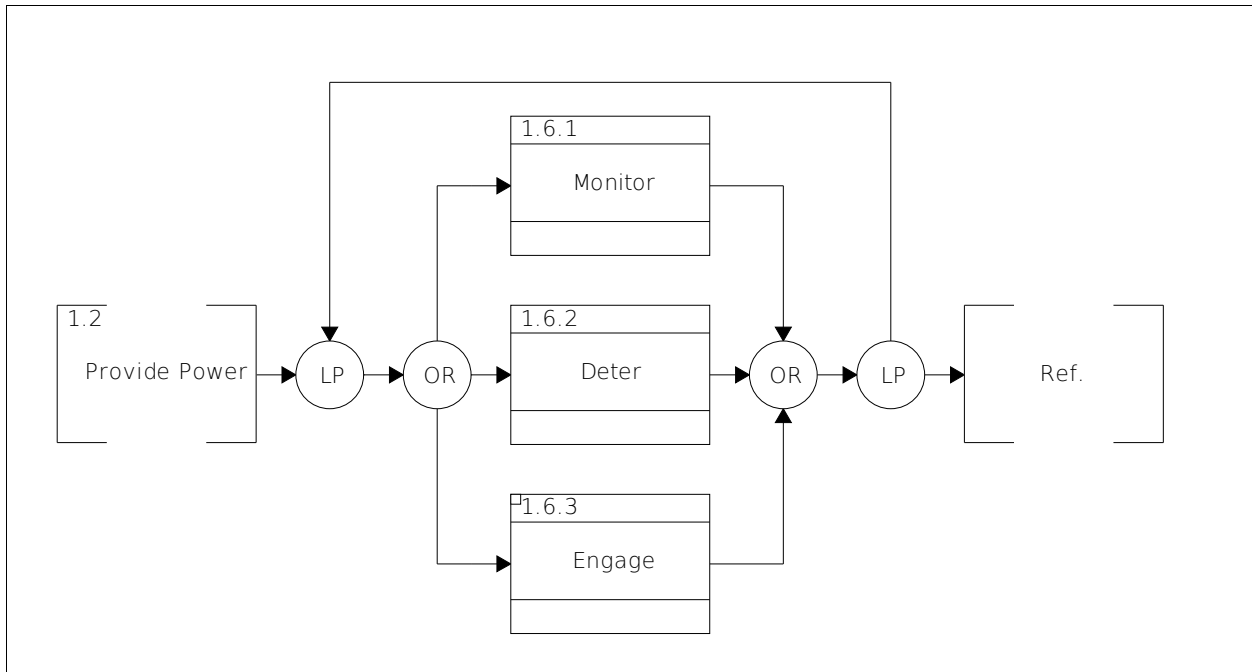

Figure D.17: Prosecute FFBD

Figure D.18 shows the FFBD for Engage (Function 1.6.3). With that function, AUWS may either employ Non-Lethal (Function 1.6.3.1) or Lethal Measures (Function 1.6.3.2). No loop is needed at this level, because iteration is provided one level up.

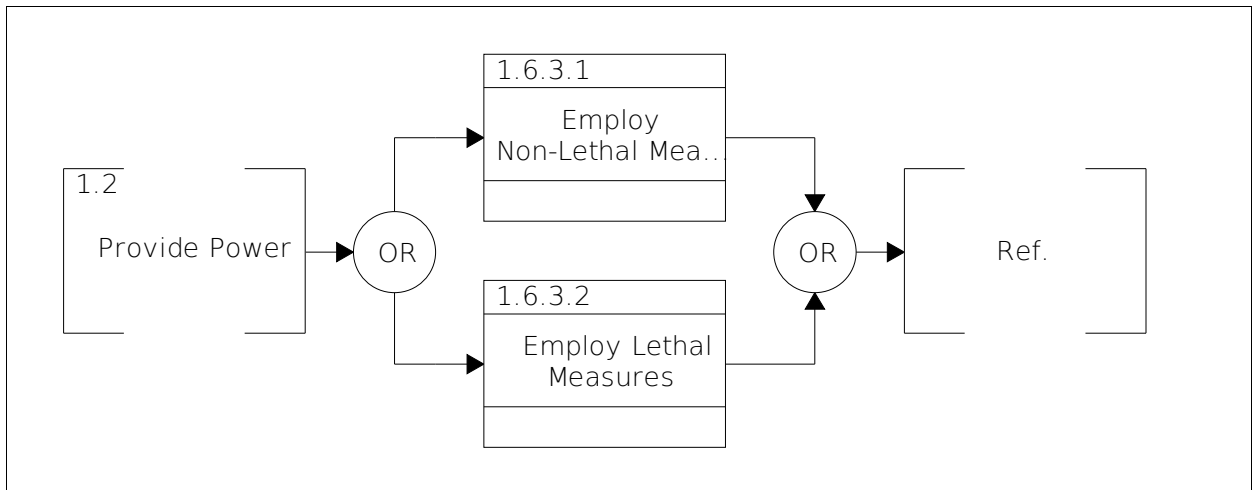

Figure D.18: Engage FFBD

1.7 Provide OPSEC

The FFBD for Provide OPSEC (Function 1.7) is shown in Figure D.19. The AND loop signifies that the system must Minimize Risk of Detection (Function 1.7.1) and Risk of Compromise (Function 1.7.2) concurrently.

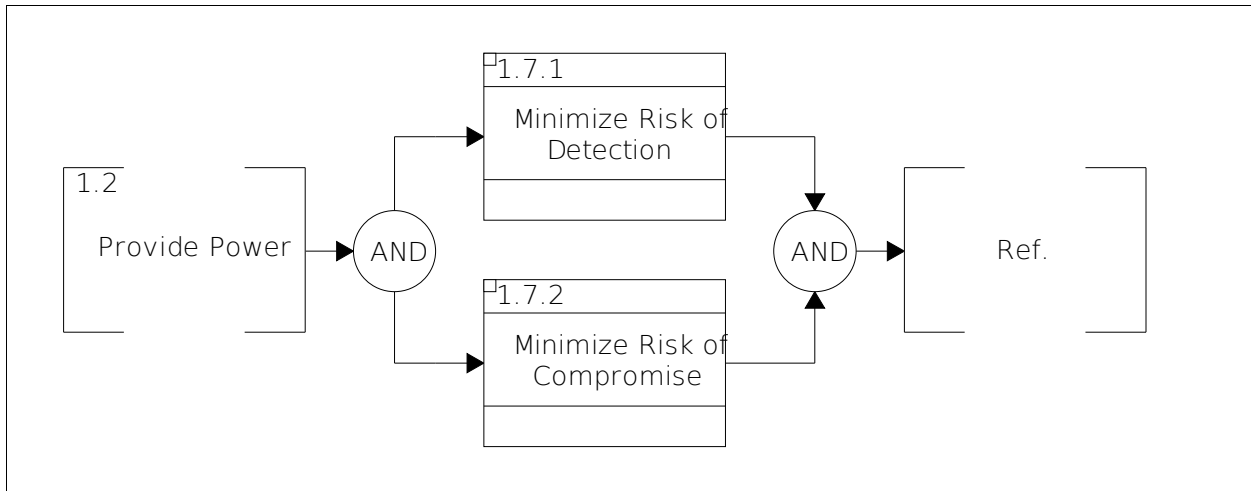

Figure D.19: Provide OPSEC FFBD

Figure D.20 is the FFBD for Minimizing the Risk of Detection (Function 1.7.1), which consists of an OR branch such that the system will either Provide EMCON (Function 1.7.1.1) or Change Operational Posture (Functional 1.7.1.2) as circumstances dictate.

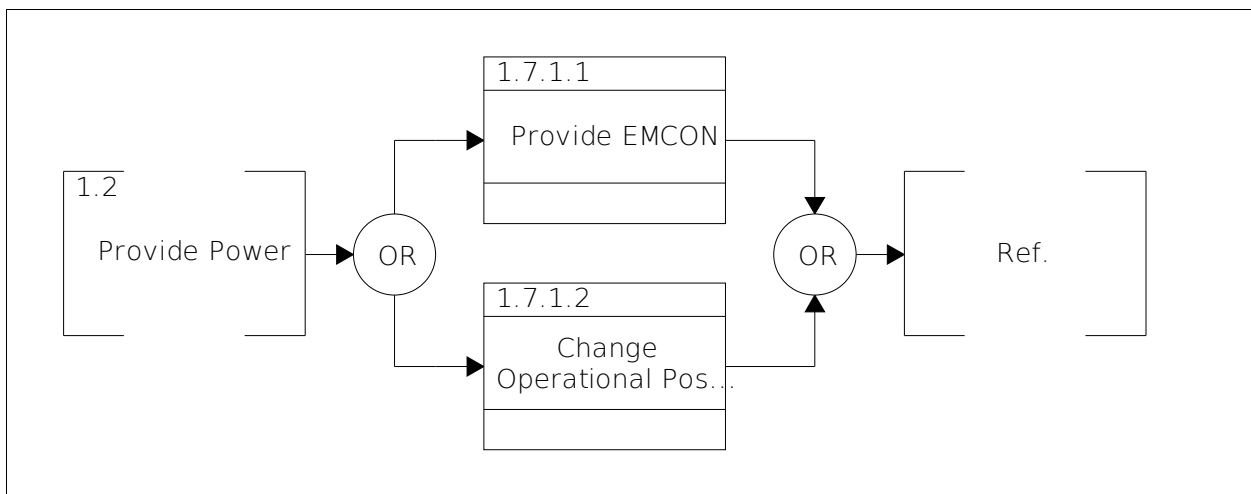

Figure D.20: Minimize Risk of Detection FFBD

Figure D.21 is the FFBD for Minimizing the Risk of Compromise (Function 1.7.2). AUWS must either Conduct Evasive Action (Function 1.7.2.1) or Self-Neutralize (1.7.2.2) to prevent compromise.

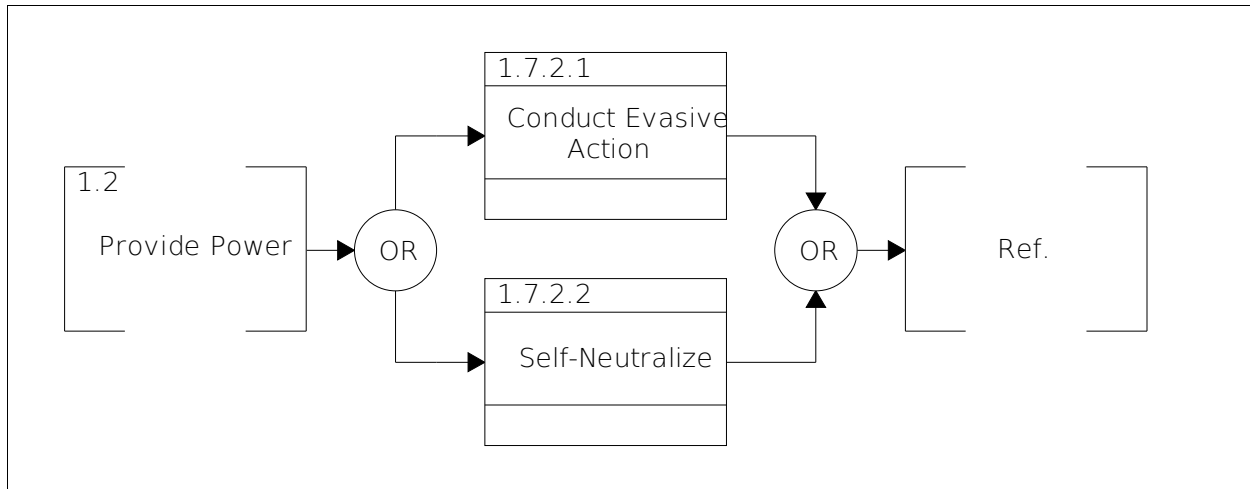

Figure D.21: Minimize Risk of Compromise FFBD

2. Integrated Definition for Function Modeling (IDEF)

Discrimination between Inputs and Controls for the IDEF0 provided automatic refinements to the FFBD series. The following diagrams and accompanying descriptions will detail overall inputs, controls, and outputs for AUWS from a top level perspective.

The language for the AUWS IDEF0 series is that inputs will enter from the left of the function box and outputs will exit from the right, while controls will enter from the top. Mechanisms were not considered, as that would imply the existence of physical constructs in a strictly functional architecture. Therefore, no data will enter the bottom of any functional box.

From Figure D.22, AUWS has the following top-level inputs, controls, and outputs:

- Inputs
 - Weapons – the warheads and associated expendables required to provide effective kinetic engagement and deterrent capabilities.
 - Resources: the fuels and expendables required to generate and provide power within an AUWS unit.
 - Materials: the parts, components, and raw materials needed to build the physical construct of the AUWS system.
 - Internal Communications: Transmissions received from other AUWS units in an AUWS network.
 - External Power: Electrical Power provided from external sources to an AUWS unit for storage.
 - External Communications: Transmissions received from sources external to the AUWS network, such as controlling asset.
- Controls
 - Software: the basic programming that governs system behavior regardless of mission requirements.
 - Mission Plan: the requirements, data, rules of engagement (ROE), and constraints provided by pre-planned mission profiles.

- Outputs
 - Asset Kill: a contact destroyed or sunken by AUWS weapons systems (preferably the desired threat contact).
 - External Transmission: data intended for an asset external to the AUWS network, such as a controlling asset, OTH shooter, or Operational Commander.
 - Internal Transmission: data intended for other AUWS units within an AUWS network.
 - Mission Kill: a contact rendered non-functional by AUWS weapons systems (preferably the desired threat contact)
 - Neutralized Unit: an AUWS unit that has rendered itself inert, unrecoverable, and otherwise destroyed to prevent compromise.
 - Recovered Unit: an AUWS unit that has been successfully recovered by a friendly asset that may be reconditioned for future use.

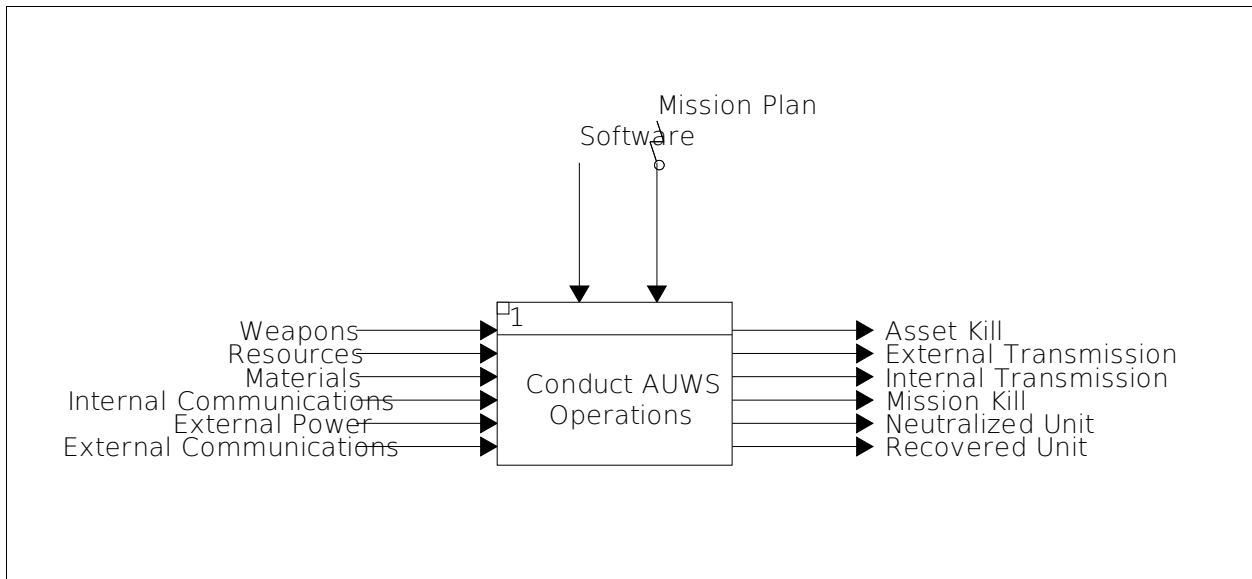

Figure D.22: AUWS A0

Opening the A0 diagram, the top level AUWS IDEF0 is revealed as shown in Figure D.23. The same six inputs, two controls, and six outputs appear as they relate to the seven primary AUWS functions. Between those seven functional boxes are internal inputs, controls, and outputs. The diagram is too cluttered to provide a concise yet accurate written description of the relationships contained therein. The next several pages will provide a brief overview of the inputs, controls, and outputs contained in Figure D.23 with accompanying A0 diagrams. All IDEF0 diagrams beyond the 1.0 level follow.

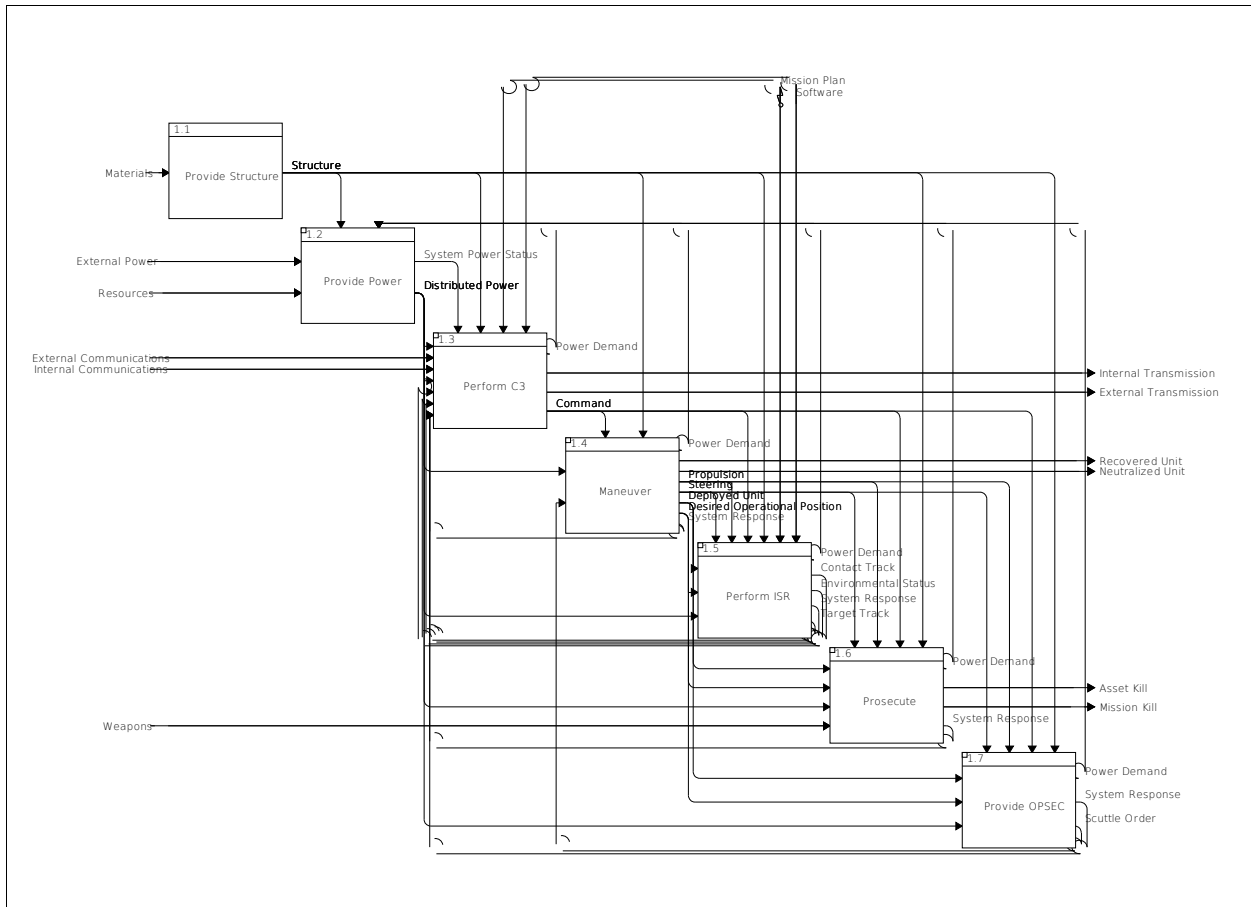

Figure D.23: AUWS IDEF0

2.1 Provide Structure

Focusing on the A0 diagram for Provide Structure in Figure D.24, the top level input of Materials is used as the sole input to the function box. The sole output is Structure, which will serve as a control for the other functions and sub-functions in the IDEF0.

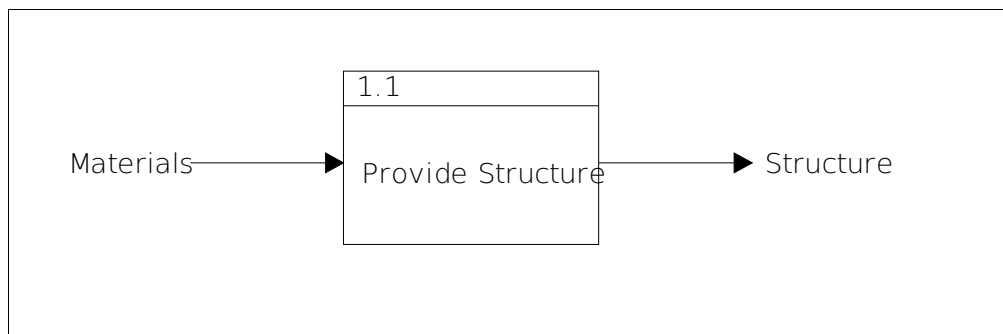

Figure D.24: Provide Structure A0

2.2 Provide Power

Figure D.25 is the A0 diagram for Provide Power (Function 1.2).

- Inputs
 - Resources: top level input.
 - External Power: top level input.
- Controls
 - Structure: physical structure provided by Function 1.1.
- Outputs
 - Distributed Power: the electrical power provided to all components of the AUWS unit.
 - System Power Status: the readiness status of the AUWS unit power system, to include remaining power, recharge capability and rates, and distribution status.

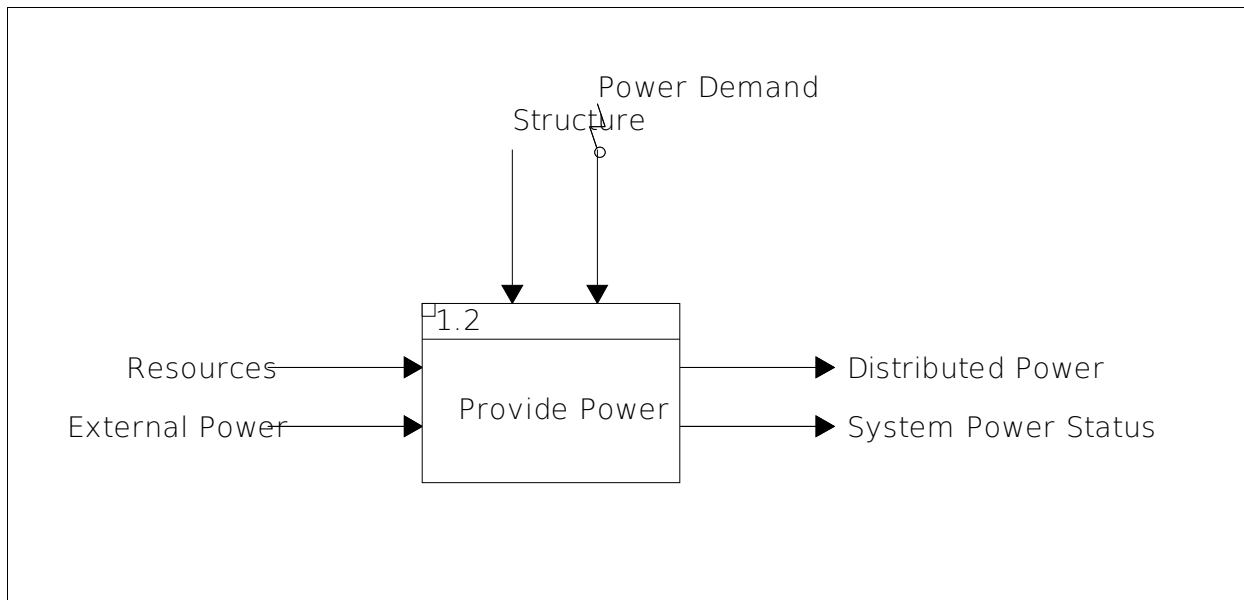

Figure D.25: Provide Power A0

2.3 Perform C3

Figure D.26 is the A0 diagram for Perform C3 (Function 1.3).

- Inputs
 - Target Track: the firing solution for a contact of interest or threat contact provided by Function 1.5.
 - System Response: Component readiness as provided by most major functions.
 - Internal Communications: top level input.
 - External Communications: top level input.
 - Environmental Status: the environmental conditions of the immediate area provided by Function 1.5.
 - Distributed Power: electrical power provided by Function 1.2.
 - Contact Track: the firing solution for a contact other than a contact of interest or threat contact provided by Function 1.5.
- Controls
 - System Power Status: power system readiness from Function 1.2.
 - Structure: physical structure provided by Function 1.1.
 - Software: top level control.
 - Mission Plan: top level control.
- Outputs
 - Command: internal order to be executed by one of the major functions of AUWS.
 - External Transmission: top level output.
 - Internal Transmission: top level output.
 - Power Demand: requirement for a specific amount of power from Function 1.2.

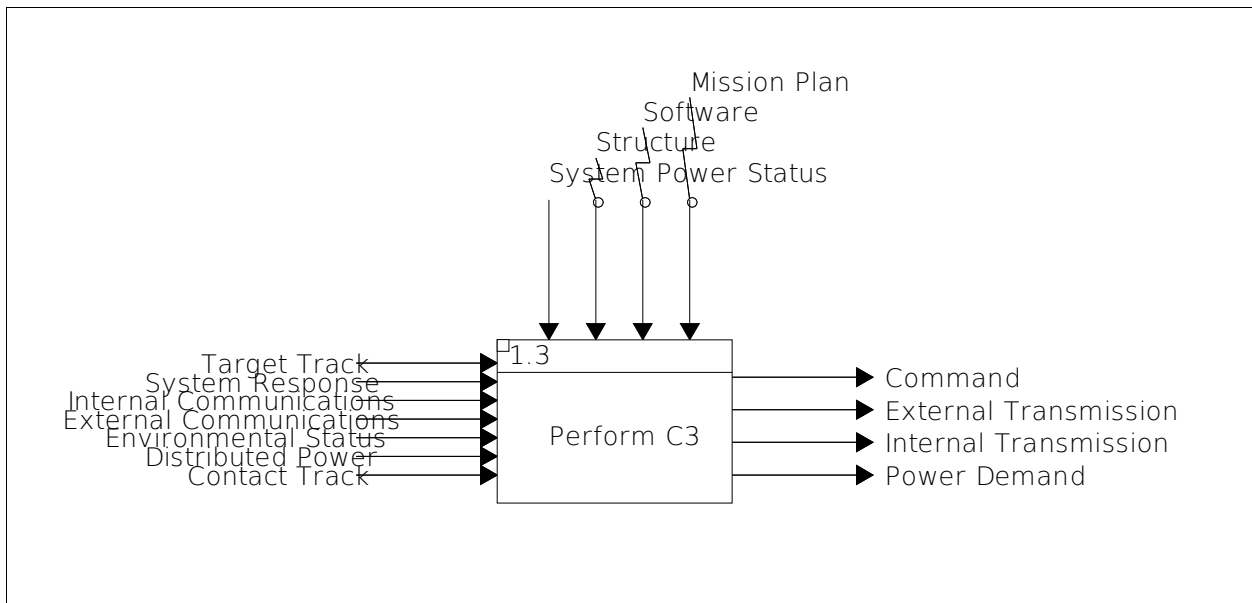

Figure D.26: Perform C3 A0

2.4 Maneuver

Figure D.27 is the A0 diagram for Maneuver (Function 1.4).

- Inputs
 - Scuttle Order: order to self-neutralize from Function 1.7.
 - Distributed Power: electrical power provided by Function 1.2.
- Controls
 - Command: internal order from Function 1.3.
 - Structure: physical structure provided by Function 1.1.
- Outputs
 - Deployed unit: an AUWS unit that has been successfully deployed.
 - Desired Operational Position: the placement of AUWS in the correct operational area; an input to Function 1.5/6.
 - Neutralized Unit: top level output.
 - Power Demand: requirement for a specific amount of power from Function 1.2.
 - Propulsion: motive force for the AUWS unit.
 - Recovered Unit: top level output.
 - Steering: positional adjustment for the AUWS unit.
 - System Response: component status provided to Function 1.3.

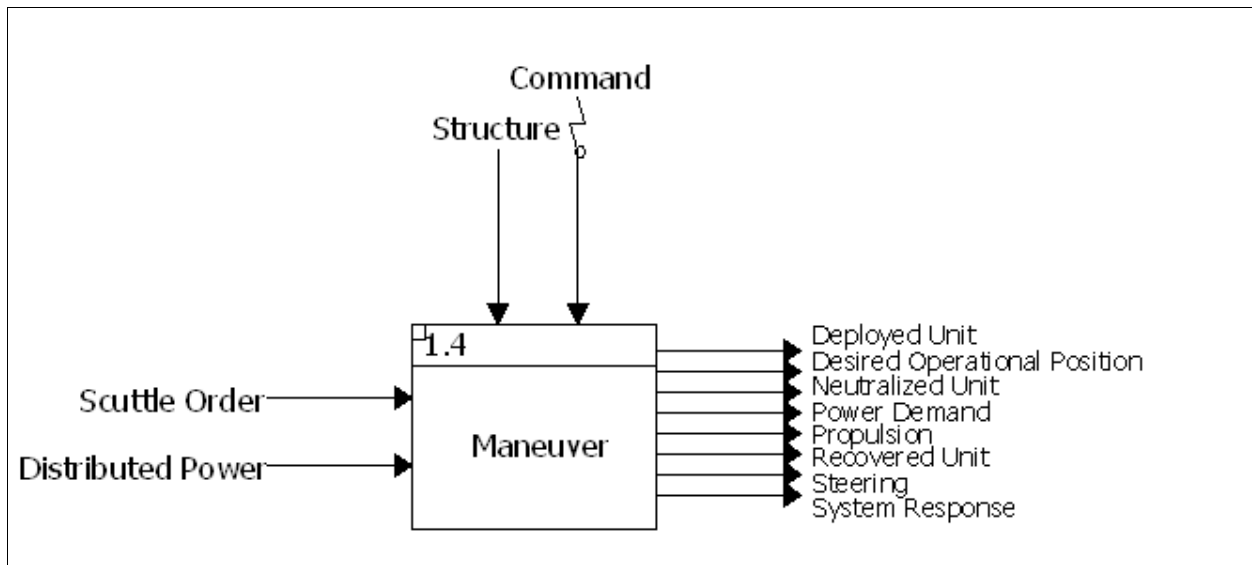

Figure D.27: Maneuver A0

2.5 Perform ISR

Figure D.28 is the A0 diagram for Perform ISR (Function 1.5).

- Inputs
 - Distributed Power: electrical power provided by Function 1.2.
 - Desired Operational Position: the placement of AUWS in the correct operational area as a result of Function 1.4.
 - Deployed unit: an AUWS unit that has been successfully deployed as a result of Function 1.4.
- Controls
 - Structure: physical structure provided by Function 1.1.
 - Steering: positional adjustment for the AUWS unit provided by Function 1.4.
 - Software: top level control.
 - Propulsion: motive force for the AUWS unit provided by Function 1.4
 - Mission Plan: top level control.
 - Command: internal order from Function 1.3.
- Outputs
 - Contact Track: the firing solution for a contact other than a contact of interest or threat contact provided to Function 1.2.
 - Environmental Status: the environmental conditions of the immediate area, provided to Function 1.3.
 - Power Demand: requirement for a specific amount of power from Function 1.2.
 - System Response: component status provided to Function 1.3.
 - Target Track: the firing solution for a contact of interest or threat contact provided to Function 1.3.

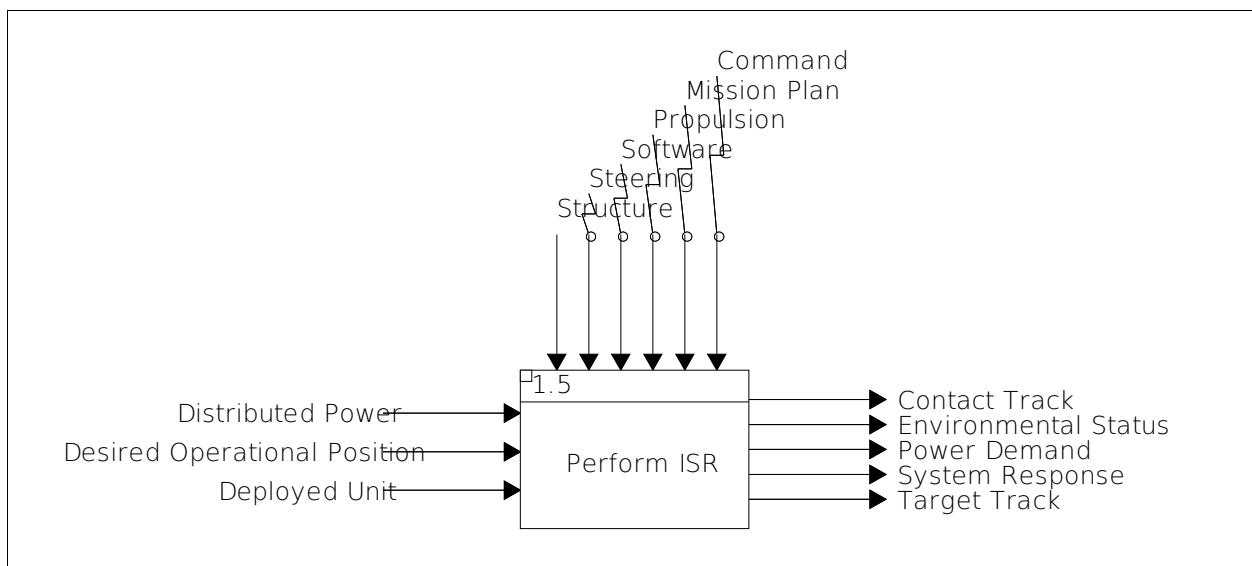

Figure D.28: Perform ISR A0

2.6 Prosecute

Figure D.29 is the A0 diagram for Prosecute (Function 1.6).

- Inputs
 - Weapons: top level input.
 - Distributed Power: electrical power provided by Function 1.2.
 - Desired Operational Position: the placement of AUWS in the correct operational area as a result of Function 1.4.
 - Deployed unit: an AUWS unit that has been successfully deployed as a result of Function 1.4.
- Controls
 - Structure: physical structure provided by Function 1.1.
 - Steering: positional adjustment for the AUWS unit provided by Function 1.4.
 - Propulsion: motive force for the AUWS unit provided by Function 1.4
 - Command: internal order from Function 1.3.
- Outputs
 - Asset Kill: top level output.
 - Mission Kill: top level output.
 - Power Demand: requirement for a specific amount of power from Function 1.2.
 - System Response: component status provided to Function 1.3.

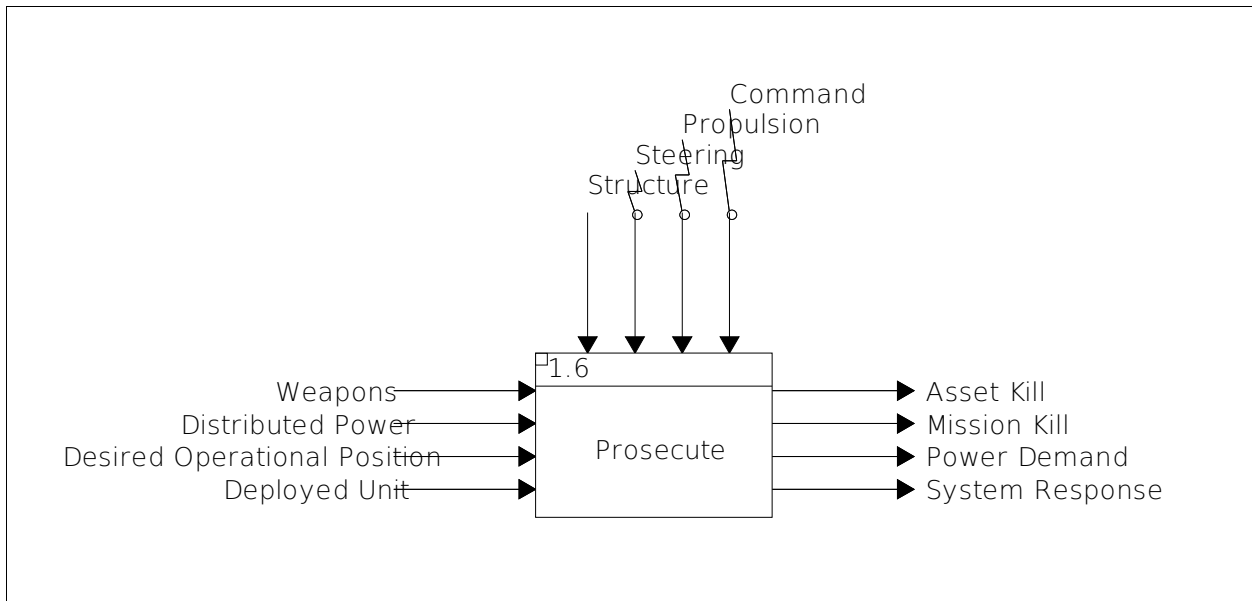

Figure D.29: Prosecute A0

2.7 Provide OPSEC

Figure D.30 is the A0 diagram for Provide OPSEC (Function 1.7).

- Inputs
 - Distributed Power: electrical power provided by Function 1.2.
 - Desired Operational Position: the placement of AUWS in the correct operational area as a result of Function 1.4.
 - Deployed unit: an AUWS unit that has been successfully deployed as a result of Function 1.4.
- Controls
 - Structure: physical structure provided by Function 1.1.
 - Steering: positional adjustment for the AUWS unit provided by Function 1.4.
 - Propulsion: motive force for the AUWS unit provided by Function 1.4
 - Command: internal order from Function 1.3.
- Outputs
 - Power Demand: requirement for a specific amount of power from Function 1.2.
 - Scuttle Order: order to scuttle; an input to Function 1.4.
 - System Response: component status provided to Function 1.3.

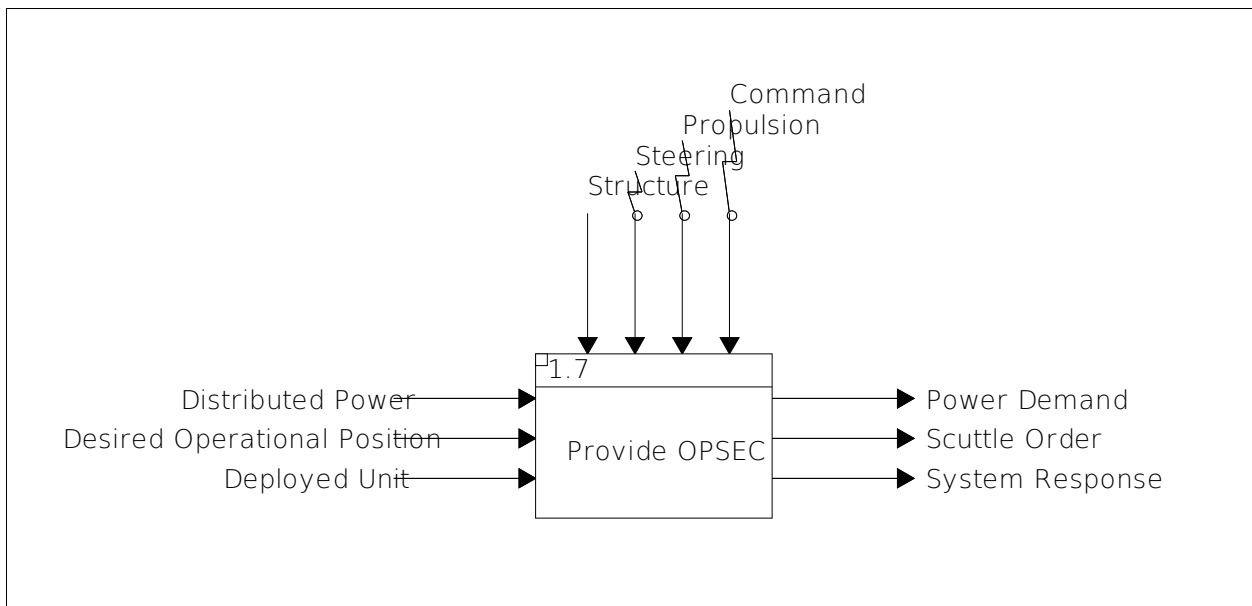

Figure D.30: Provide OPSEC A0

The IDEF0 analysis constituted the final portion of the Functional Analysis, validating the Functional Decomposition and FFBD. Best of all, the top level A0 provided an easy visual representation of the I/O requirements for the system which allowed a traceability check with needs analysis as well as a list of tangibles from which to derive requirements.

2.8 Lower Level IDEF0 Diagrams

2.8.1 Provide Structure

Not applicable.

2.8.2 Provide Power

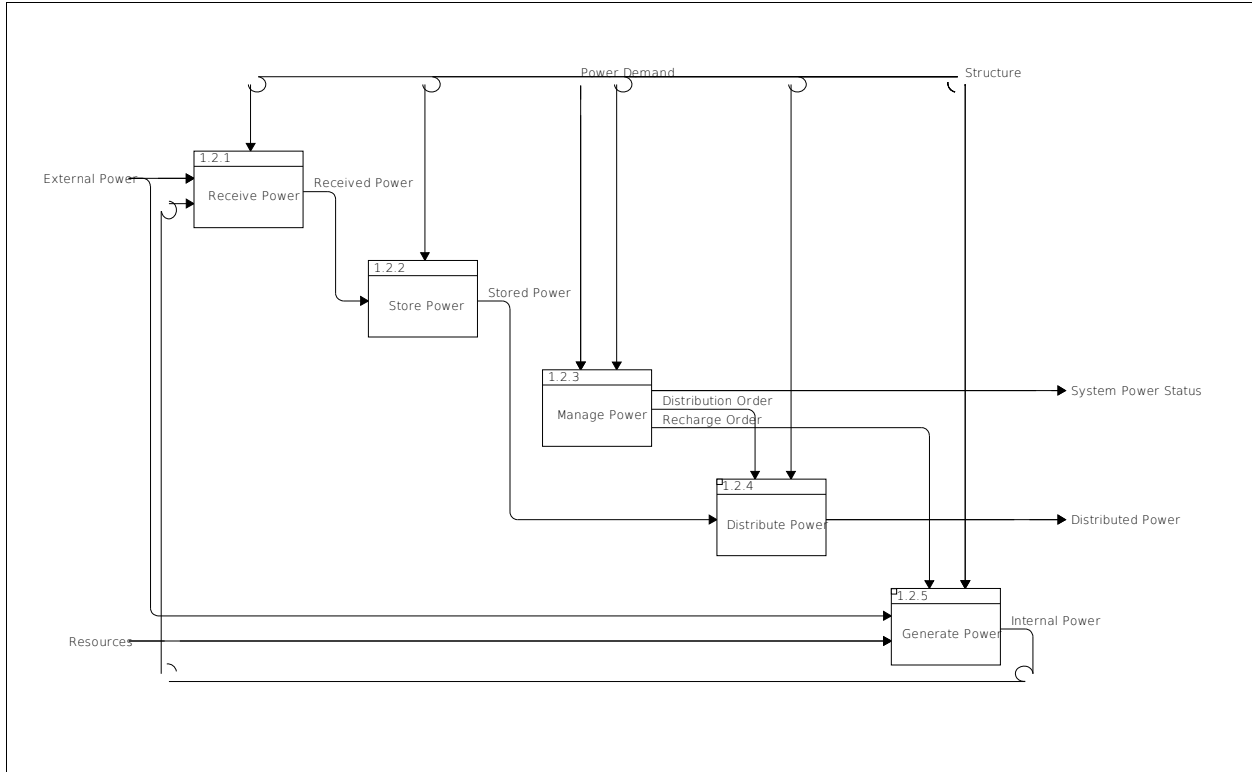

Figure D.31: Provide Power IDEF0

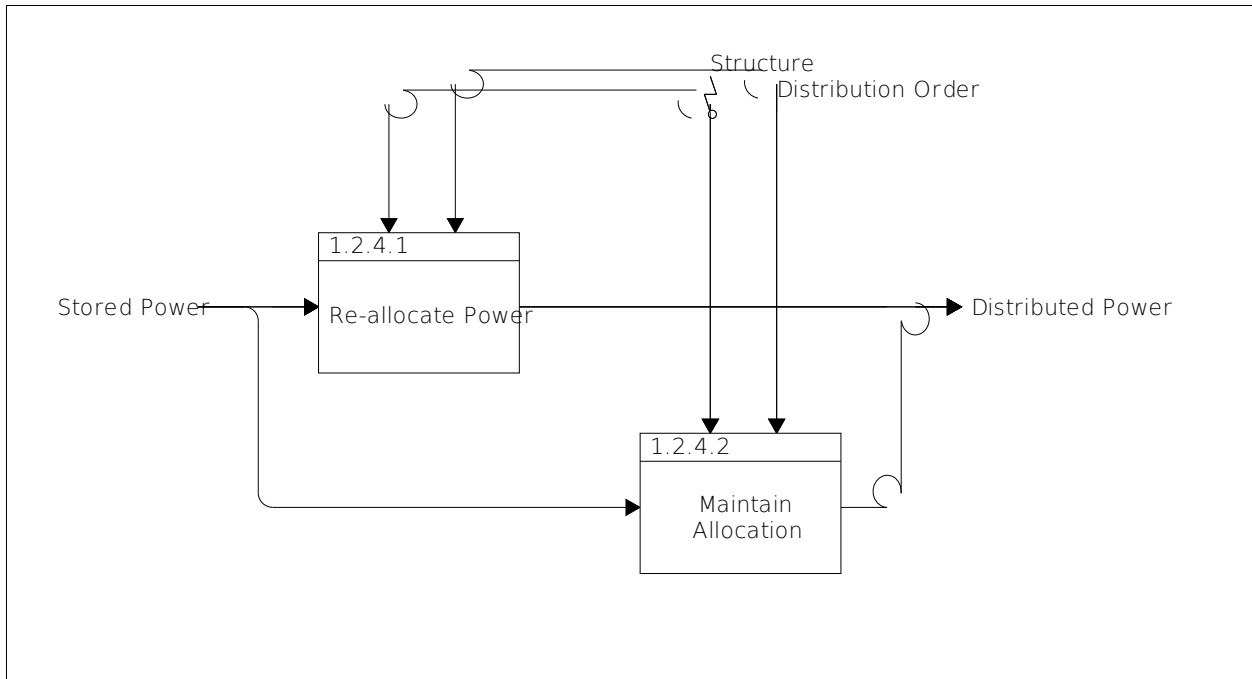

Figure D.32: Distribute Power IDEF0

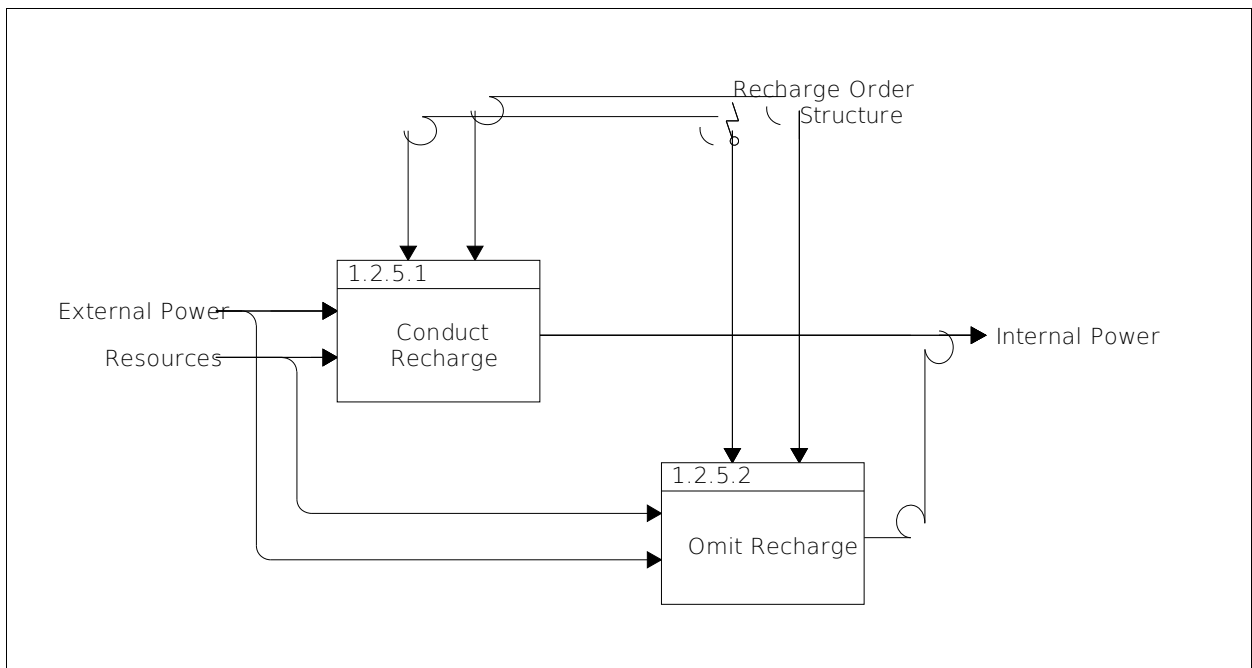

Figure D.33: Generate Power IDEF0

2.8.3 Perform C3

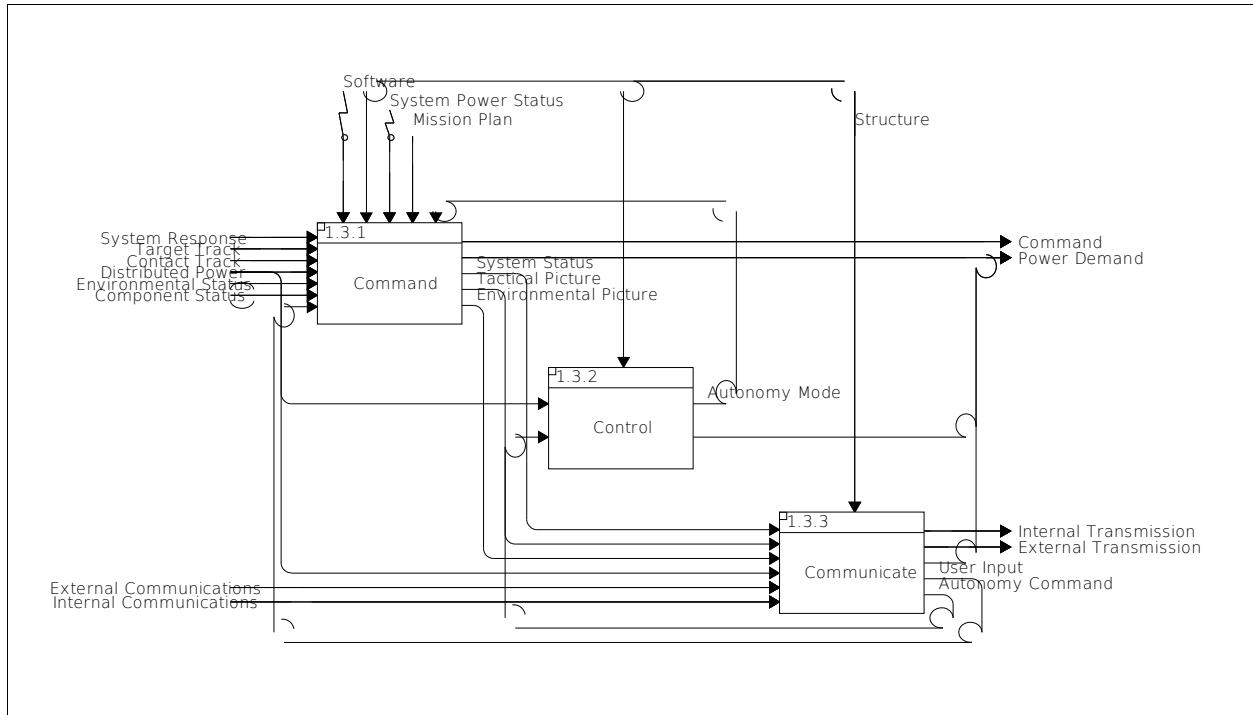

Figure D.34: Perform C3 IDEF0

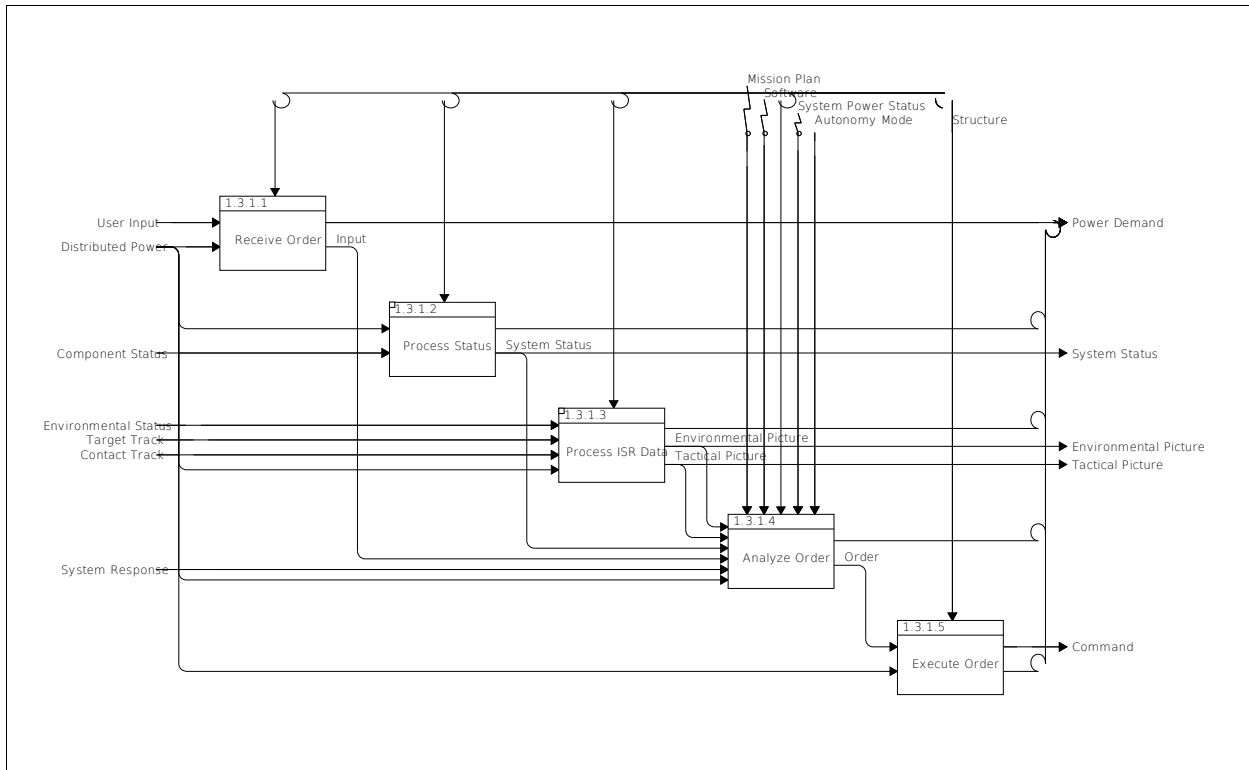

Figure D.35: Command IDEF0

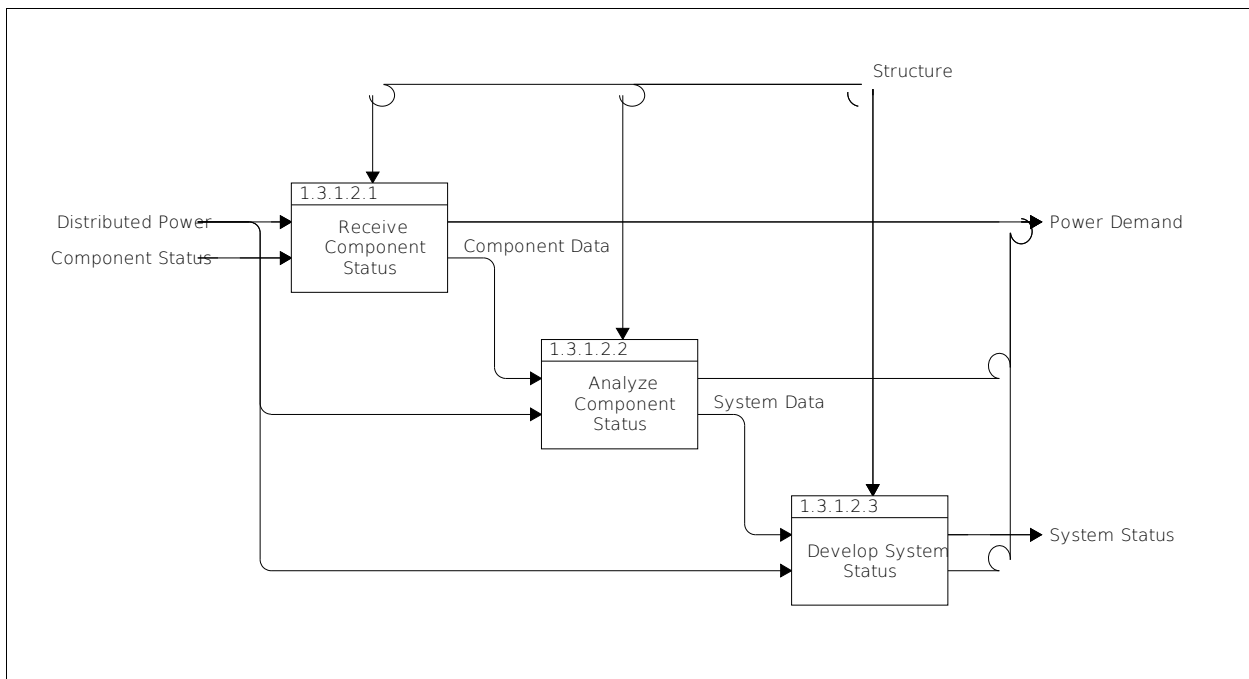

Figure D.36: Process Status IDEF0

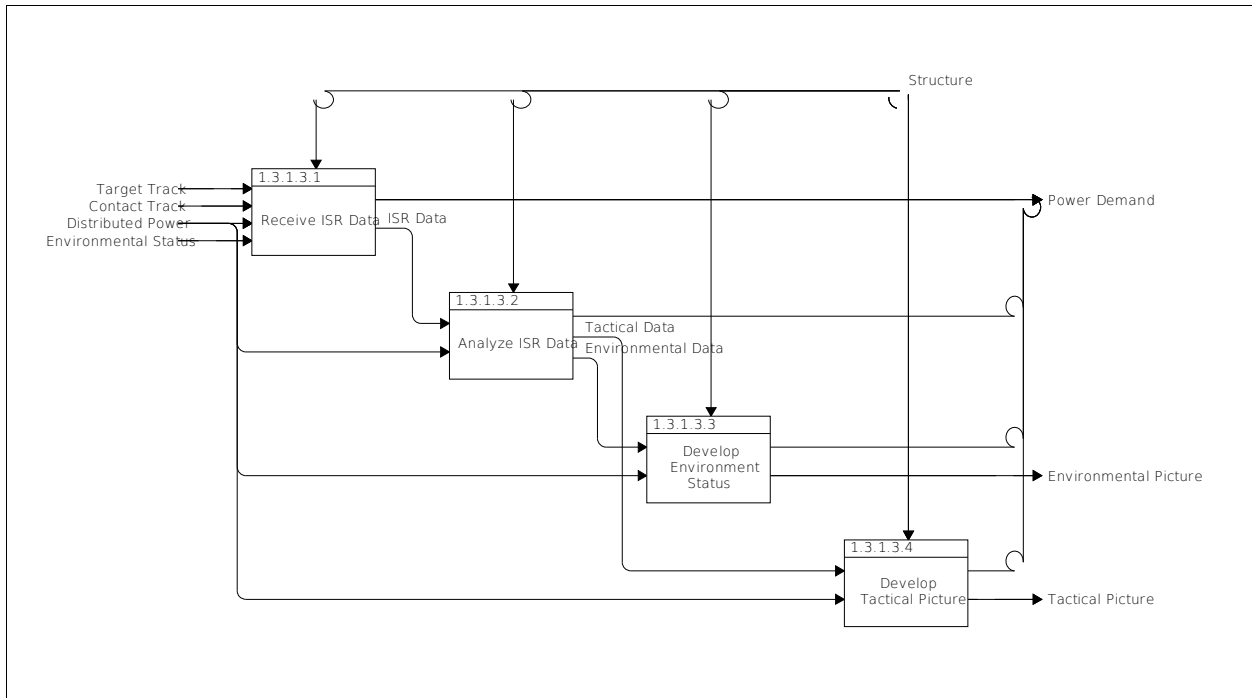

Figure D.37: Process ISR Data IDEF0

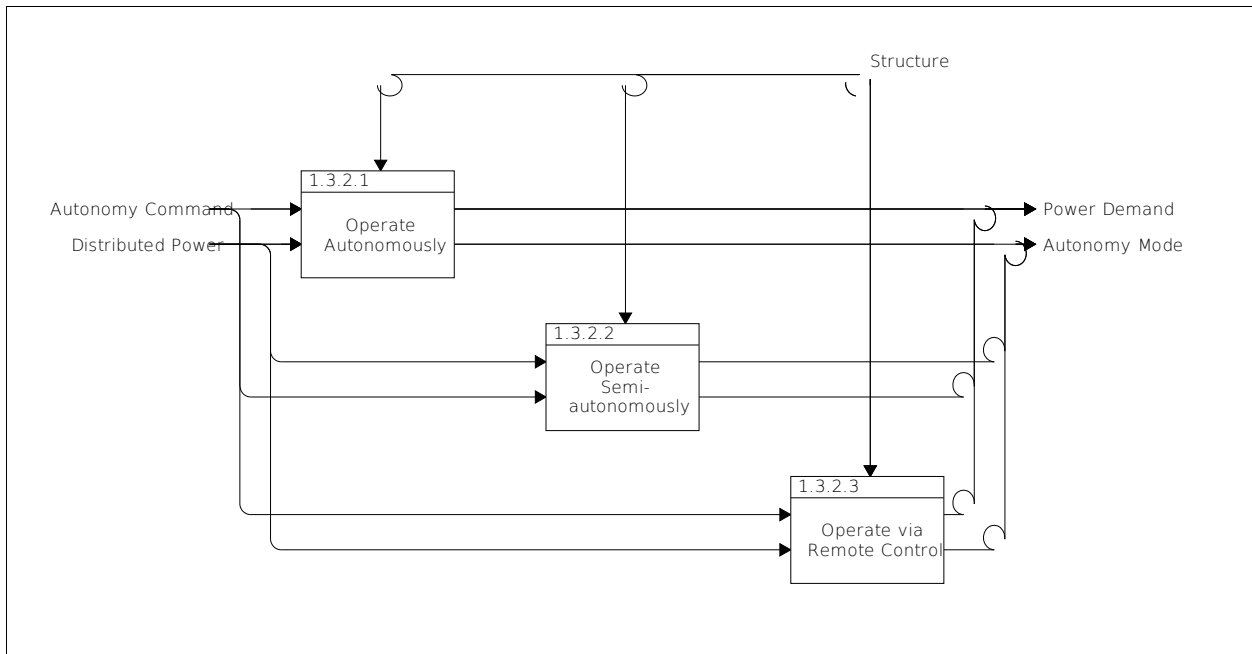

Figure D.38: Control IDEF0

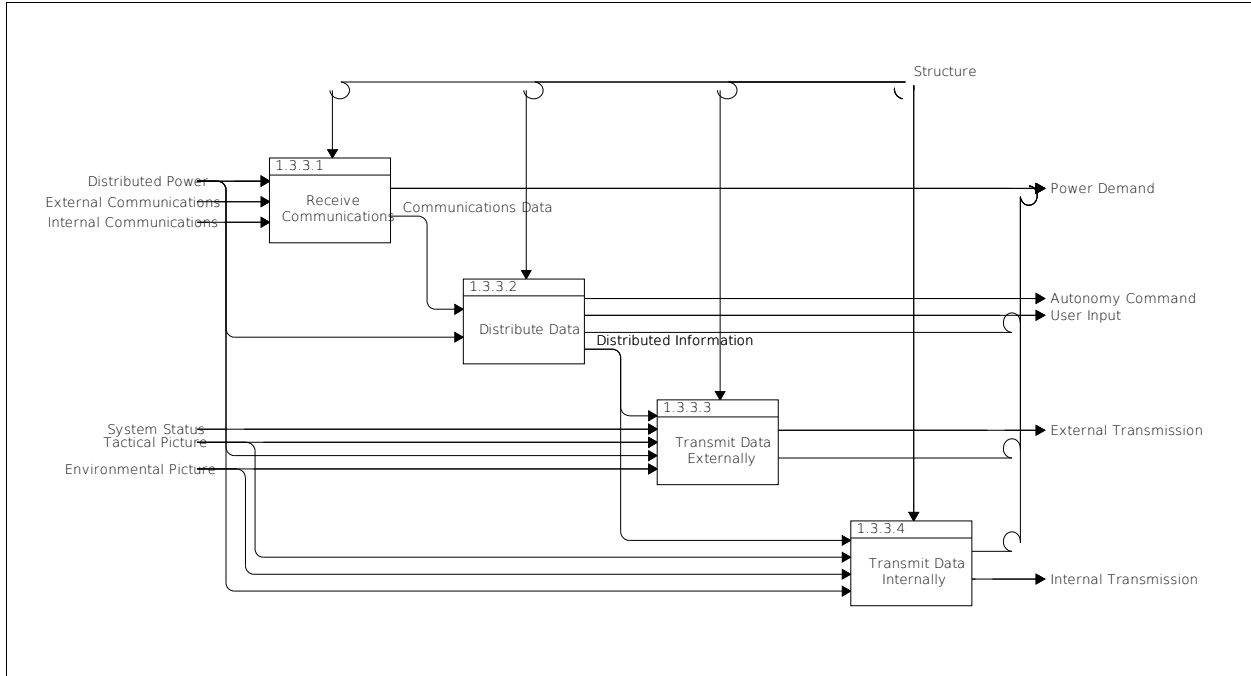

Figure D.39: Communicate IDEF0

2.8.4 Maneuver

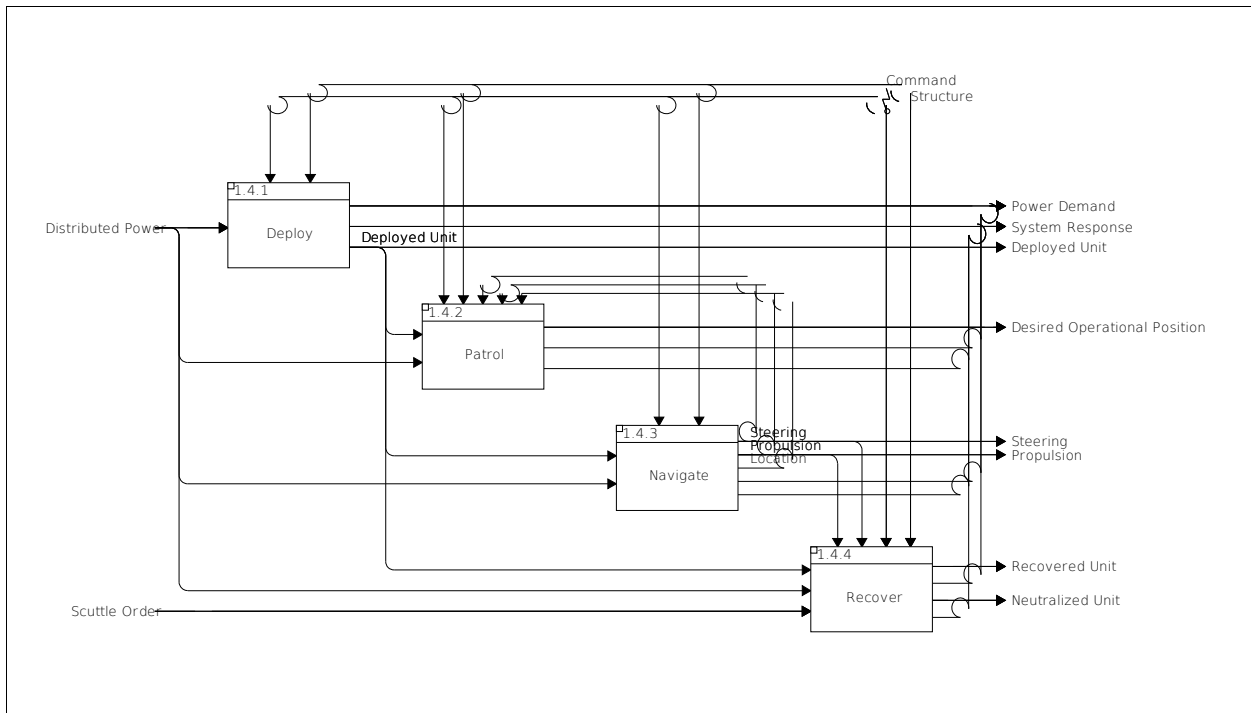

Figure D.40: Maneuver IDEF0

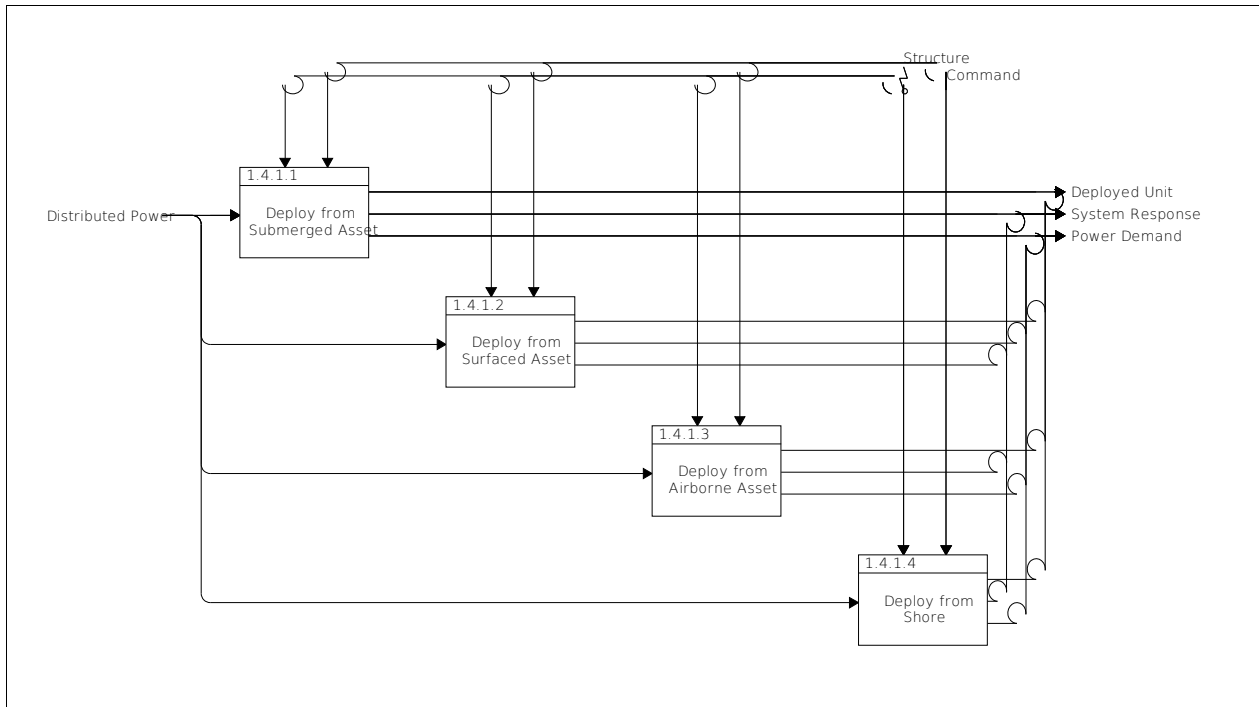

Figure D.41: Deploy IDEF0

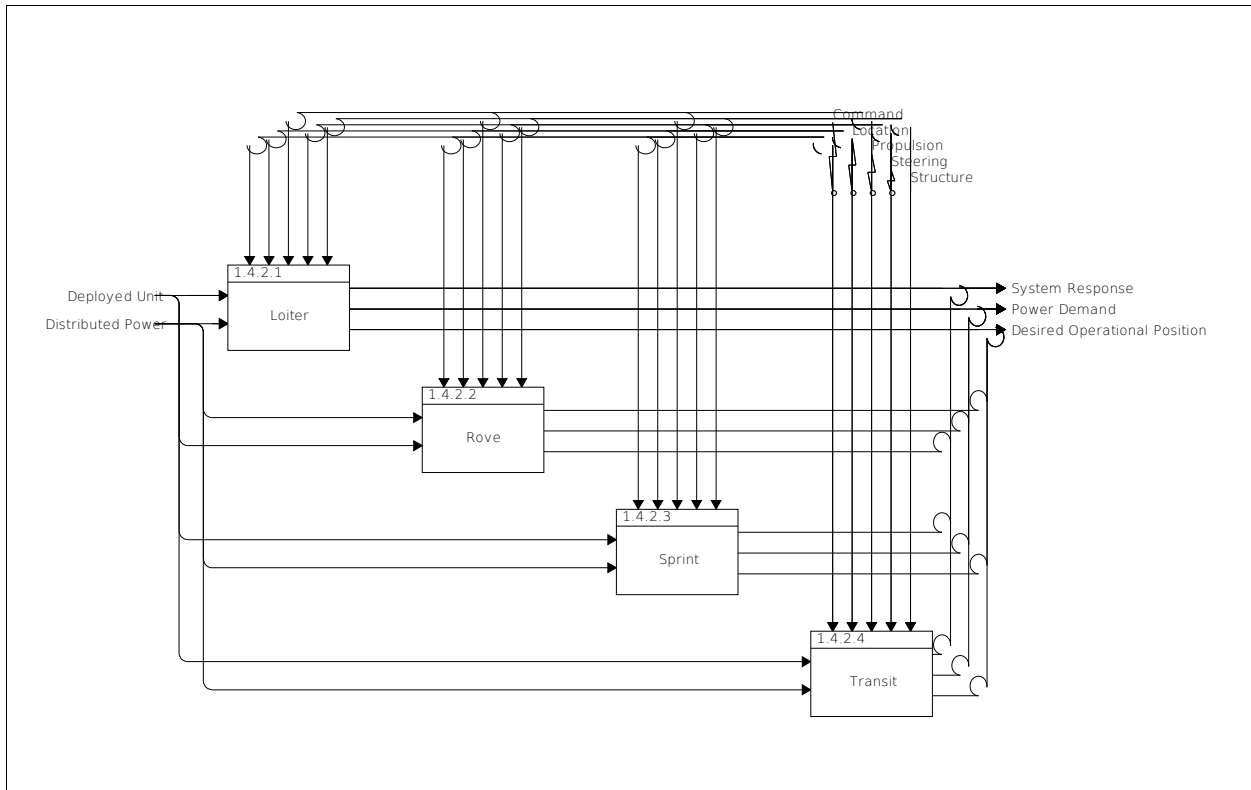

Figure D.42: Patrol IDEF0

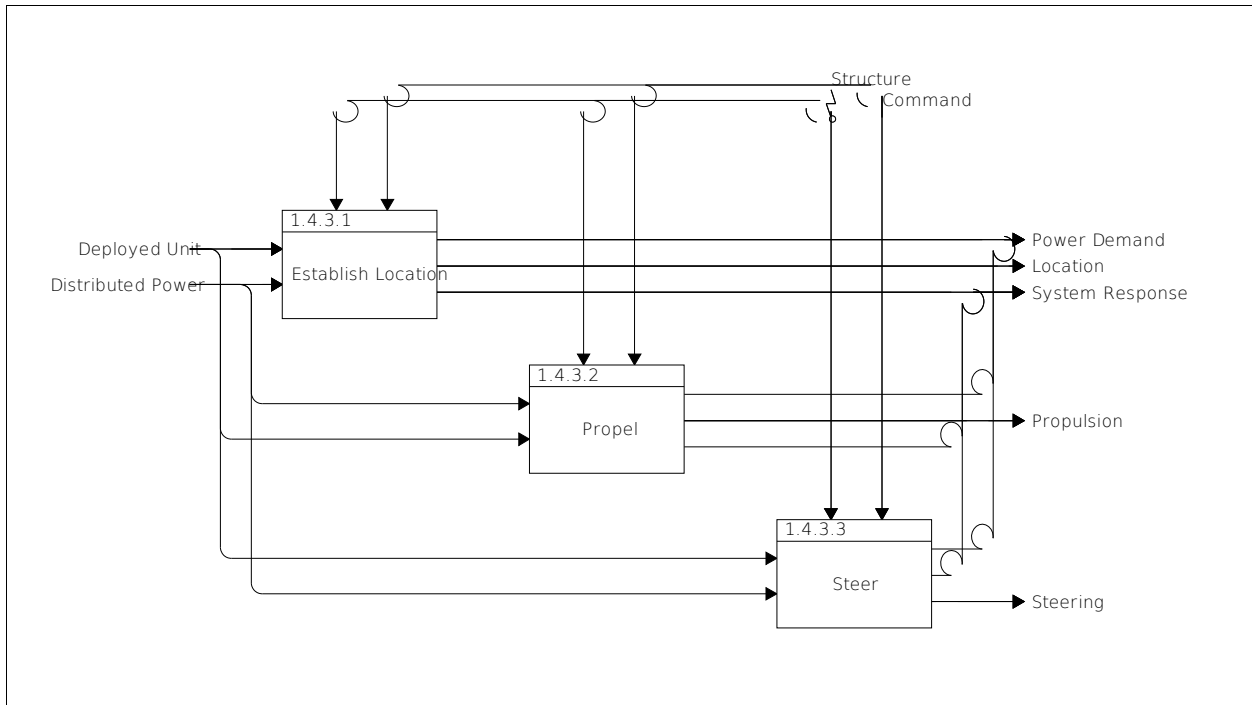

Figure D.43: Navigate IDEF0

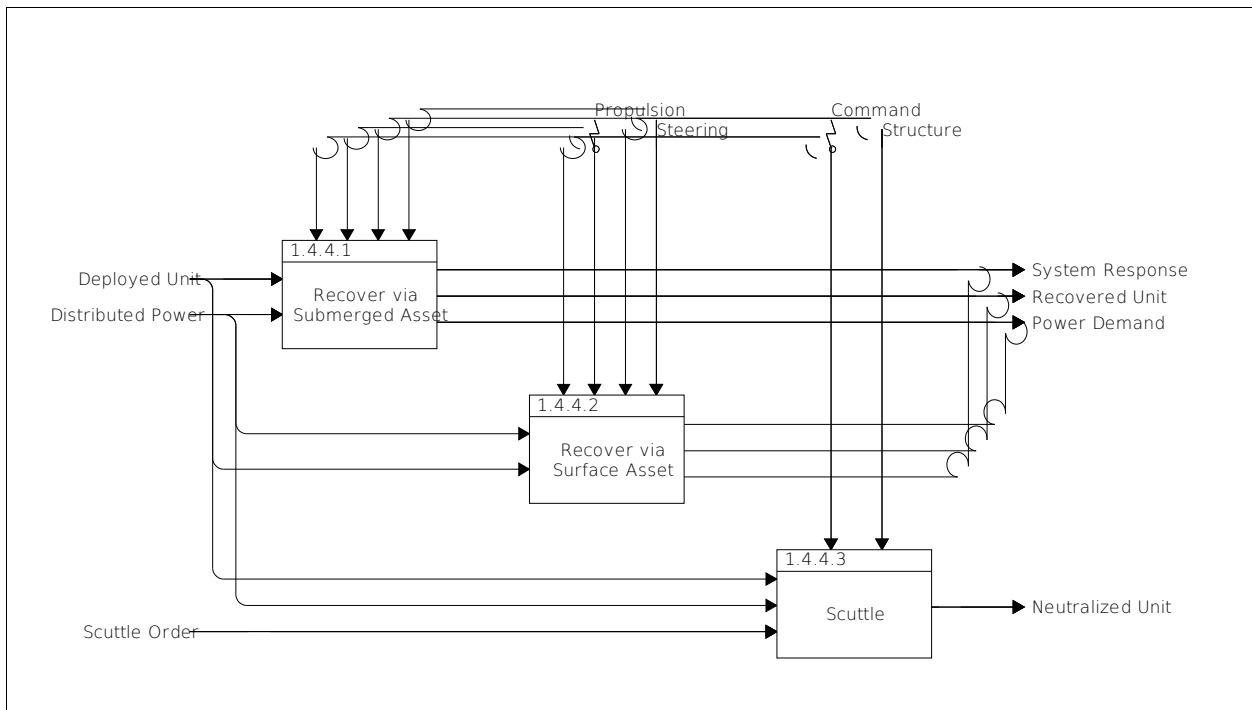

Figure D.44: Recover IDEF0

2.8.5 Perform ISR

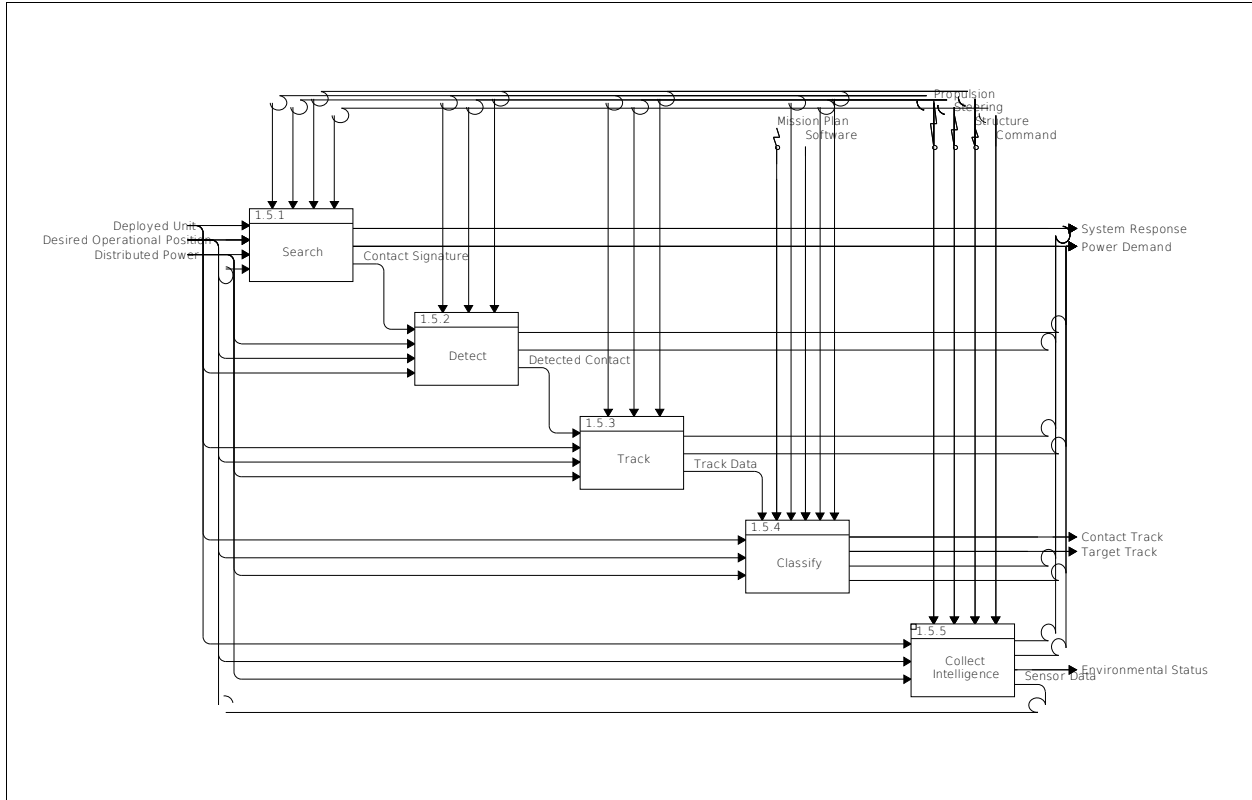

Figure D.45: Perform ISR IDEF0

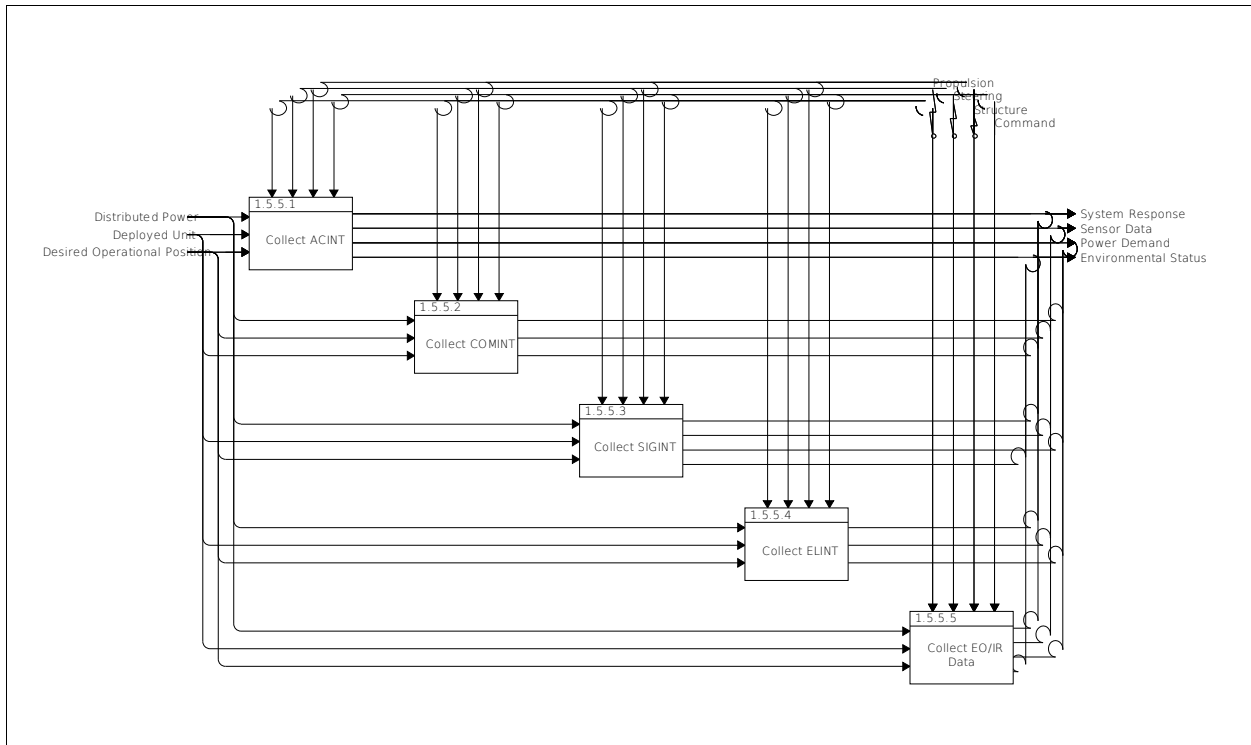

Figure D.46: Collect Intelligence IDEF0

2.8.6 Prosecute

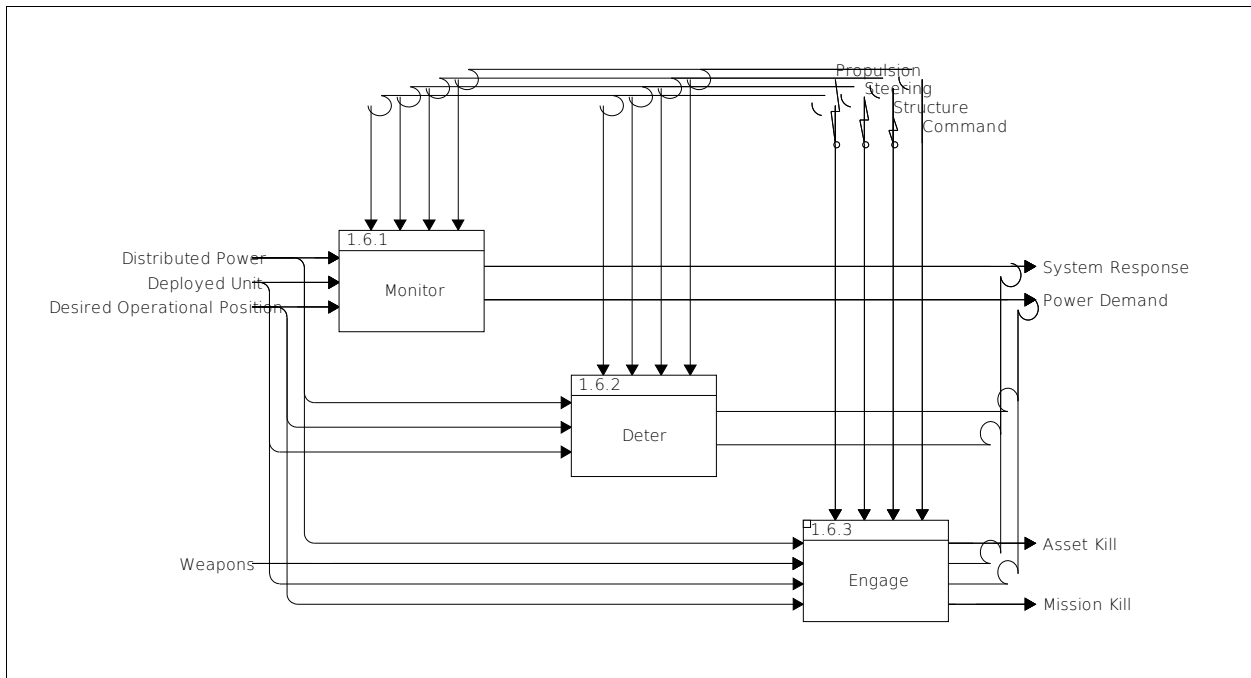

Figure D.47: Prosecute IDEF0

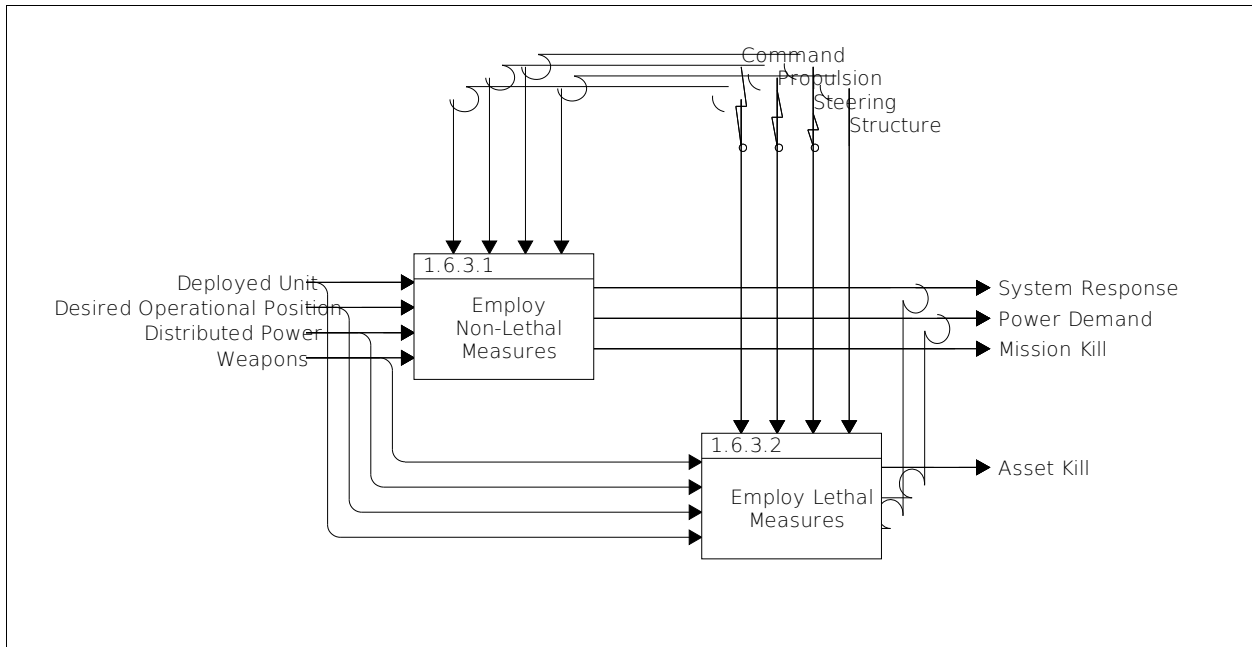

Figure D.48: Engage IDEF0

2.8.7 Provide OPSEC

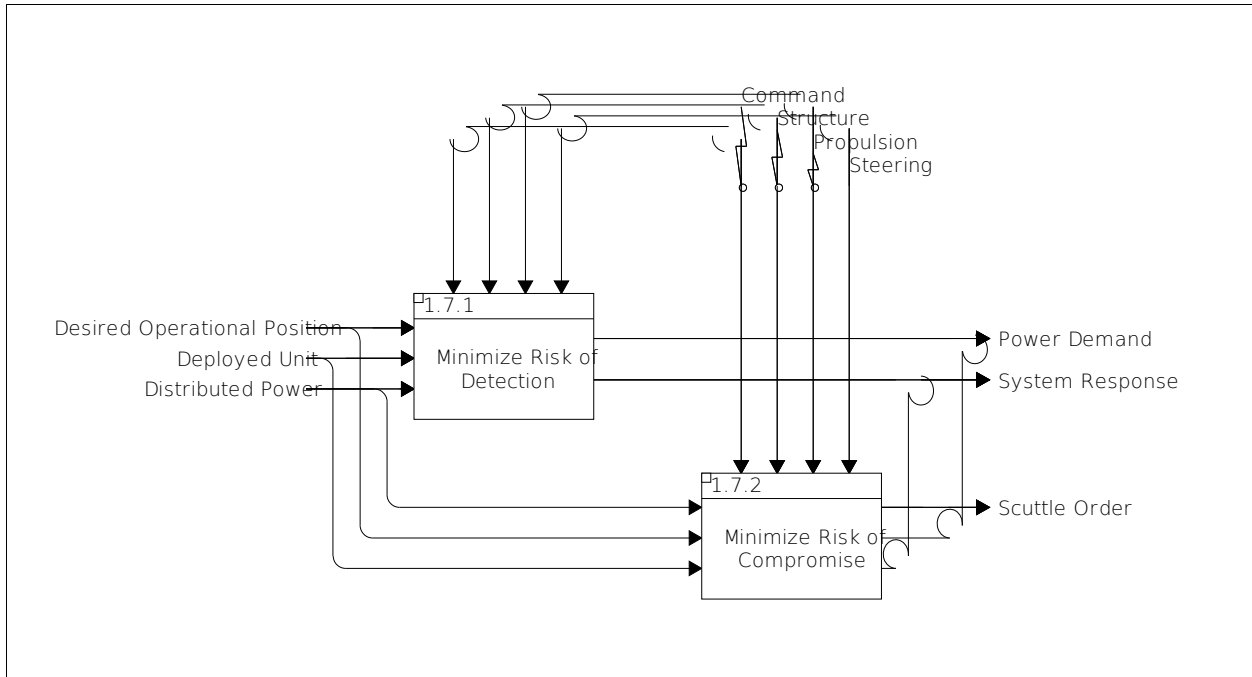

Figure D.49: Provide OPSEC IDEF0

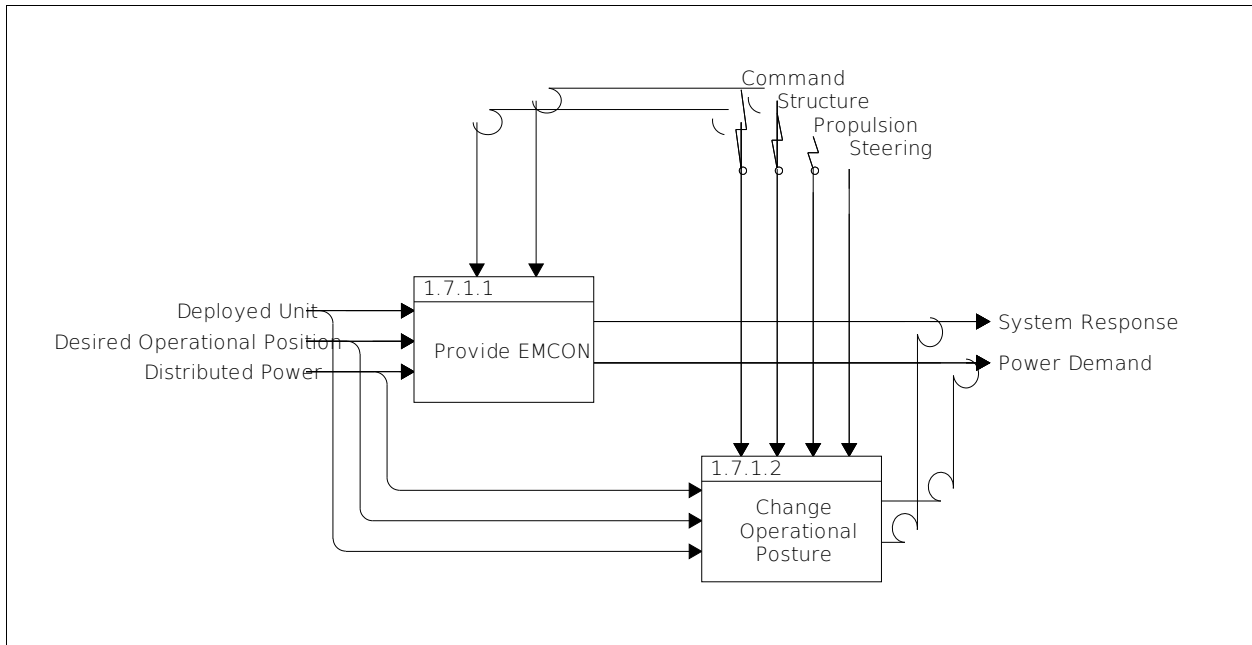

Figure D.50: Minimize Risk of Detection IDEF0

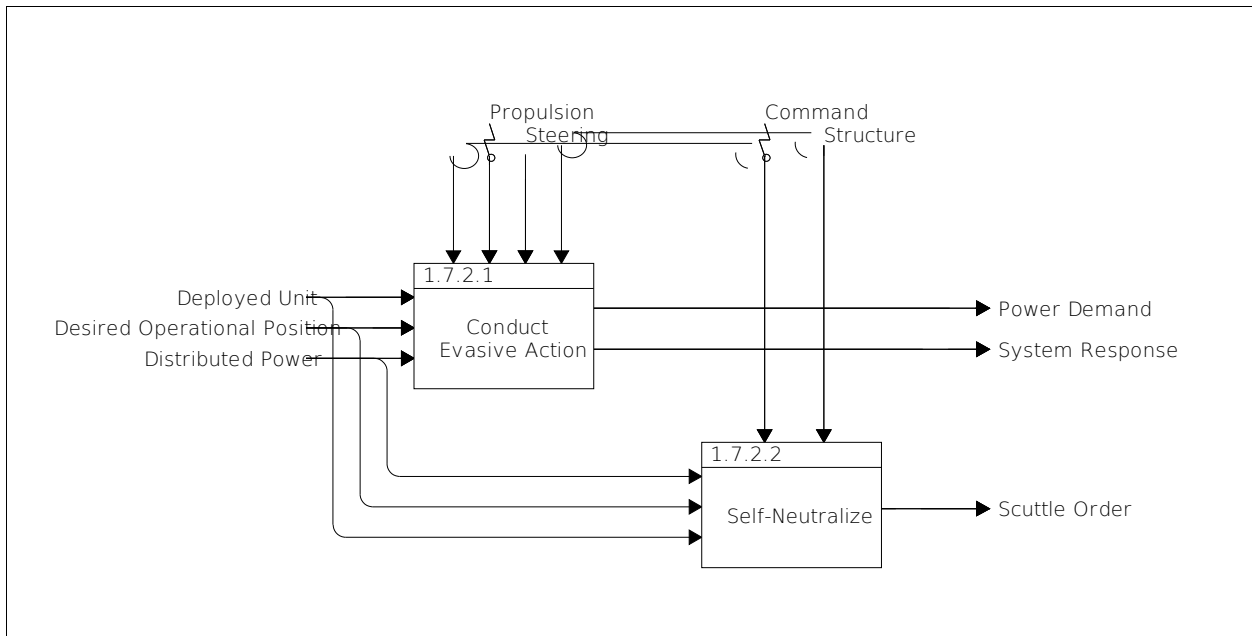

Figure D.51: Minimize Risk of Compromise IDEF0

Appendix E: Technology Review

This analysis considers a wide range of promising and popular technologies, terms which are not always synonymous. Not all technologies considered are included in system concepts and thoroughly analyzed. The systems briefly described here are a small representation of programs currently being tested and evaluated. In an effort to only consider technologies mature enough to be fully mission capable in 2030, technology readiness levels (TRL), are used to indicate the maturity of a system or the technological risk, as shown in Figure E.1. When a program is first conceptualized, the technical risk is high, and the TRL of the system is low. Immature technologies have a higher risk of surpassing a pre-established budget or schedule and are likely to cause program failure.

This analysis pursues system solutions at TRL 5 and above. It is the assessment of the Project Team that all technologies included in system concepts will be able to successfully enter into the DoD's acquisition process with enough maturity to provide for operational deployment by 2030. The following review provides a representative sample of the technologies considered potentially viable at the outset of the alternative generation process.

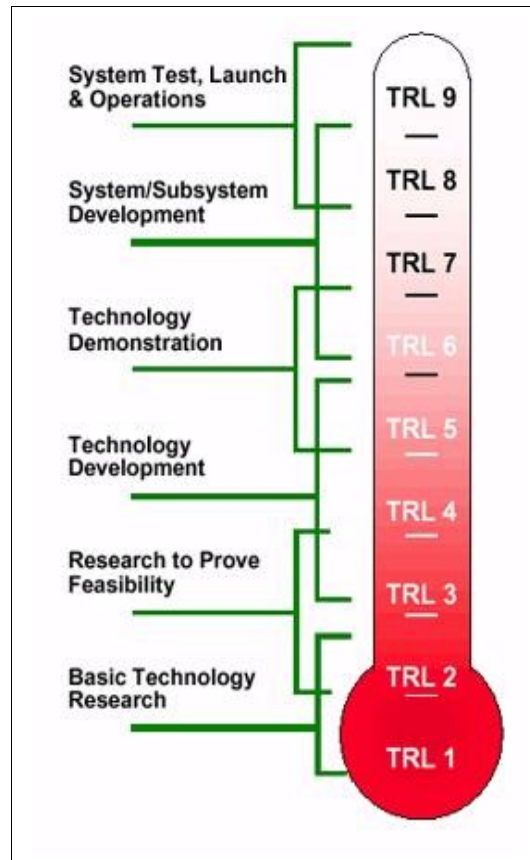

Figure E.1: NASA TRL Meter¹⁴²

142 National Aeronautics and Space Administration. "NASA TRL Meter." Washington: NASA, 2004.

Weapons: The current US Navy’s mine inventory consists of the Quickstrike family of aircraft laid, shallow water, bottom mines, Figure E.2, and the Submarine Launched Mobile Mine (SLMM), Figure E.3. Over the years, Quickstrike mines have received only minimal updates, with the most recent modification in 2007 consisting of target detection, safety, and battery improvements. Initiated in 1969, Quickstrike mines are essentially General Purpose Bombs that have been tailored and re-fitted for use as naval mines.¹⁴³



Figure E.2: Quickstrike Family of Mines¹⁴⁴

The SLMM, a modified Mk-37 torpedo, provides covert mining for hostile or areas otherwise inaccessible to deployment platforms. Once on station, the SLMM functions as a standard shallow water bottom mine. Original versions of the SLMM are being phased out, while development of an improved SLMM, with two deployable mines and greater range and precision, stopped in 2002.^{145 146} The specifications for the SLMM are outlined in Table E.1.

143 United States Navy Fact File. "U.S. Navy Mines" 15 Jan. 2009.

<http://www.navy.mil/navydata/fact_display.asp?cid=2100&tid=700&ct=2>.

144 Martin, Gifford. *Quickstrike (QS) Mod 3 Program Overview*. Nov. 2009

145 Federation of American Scientists. "Submarine-Launched Mobile Mine (SLMM)." 12 Dec. 1998. *fas.org*. 19 May 2011. <<http://www.fas.org/man/dod-101/sys/ship/weaps/slmm.htm>>.

146 Truver, Scott C. "What 'Weapons That Wait?'" *Seapower*. Jun. 2011. 6.



Figure E.3: Submarine Launched Mobile Mine

Table E.1: SLMM Specifications

Weight	1,765 pounds / 1658 pounds (754 kilograms)
Length	13' 4" / 161 inches (409 centimeters)
Width	1' 9" / 19 inches (48.5 centimeters)
Detection System	Magnetic/seismic or Magnetic/seismic/pressure target detection devices (TDDs)
Depth Range	Up to 600 feet (183 meters)
Explosives	330 pounds (150 kilograms) of high explosive
Date Deployed	1983

Weapons needed in the 2030 time frame will need to be far superior to the current US mine inventory. Miniature torpedoes, like the Compact Rapid Attack Weapon (CRAW), are an example of how technology is progressing. Modified from the defensive Common Very Lightweight Torpedo (CVLWT), Figure E.4, the CRAW is designed as an offensive variant, capable of being carried by a wide range of platforms, including UAVs and UUVs. The CRAW

provides a mission kill by homing in on a target's propeller, rudder, or other mission critical system.¹⁴⁷

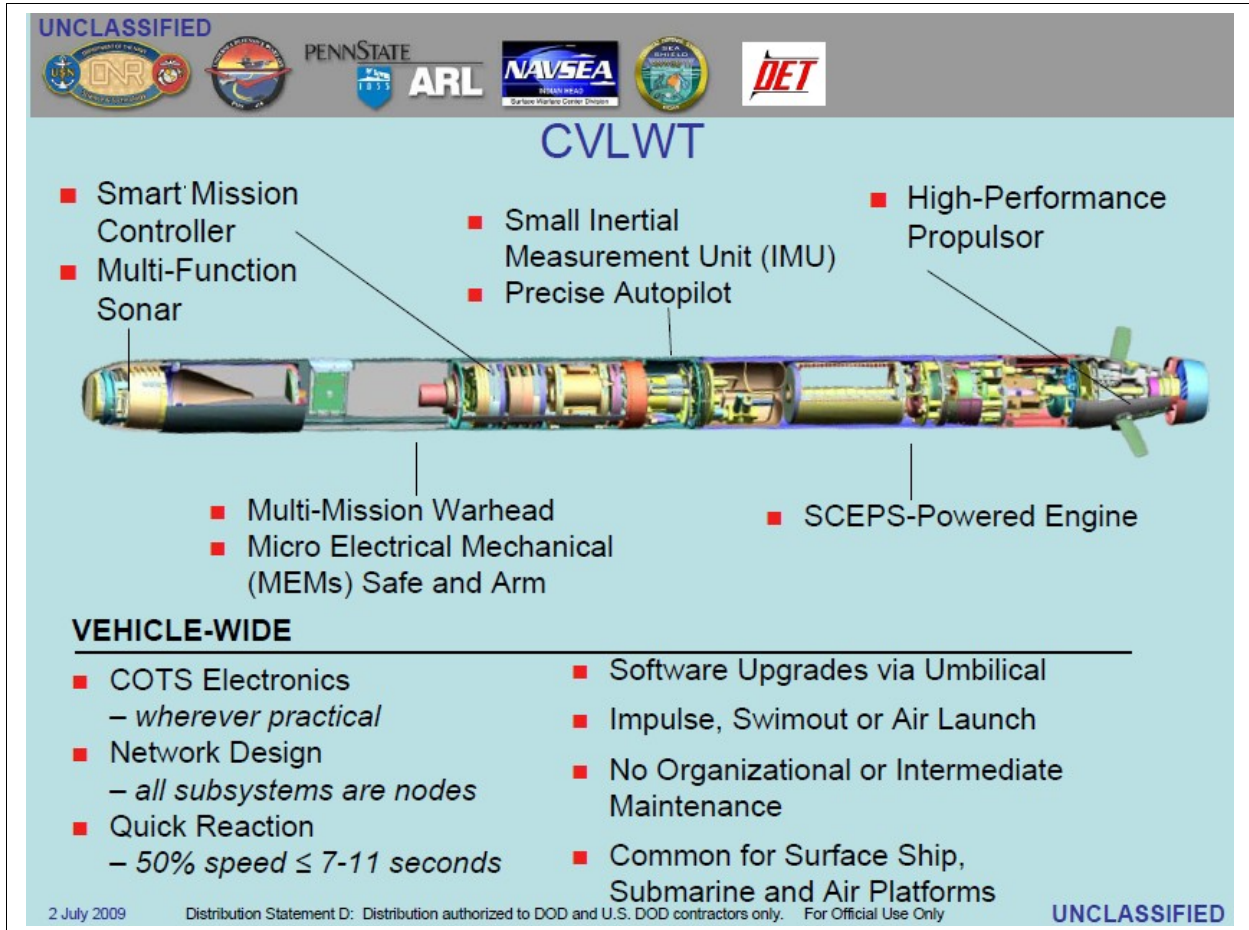

Figure E.4: CVLWT (same hardware as CRAW)¹⁴⁸

Distributed Undersea Networks: Distributed undersea networks are a promising way to improve sensor coverage without relying on large, expensive platforms. Several technologies are currently under development that take advantage of this opportunity. One such technology is Seaweb, Figure E.5, a program being developed at NPS. Seaweb is an underwater communications network that consists of many acoustic sensor nodes and a gateway node. Each sensor node communicates to each other, wirelessly, using acoustic modems. The surfaced gateway node houses radio communication equipment to communicate with command and control centers, either directly or via airborne or satellite relay. Currently, these gateway nodes allow near real time bi-directional communication capabilities. Additionally, Seaweb enables submarines, and potentially UUVs, to be equipped with a node and thus have access to the deployed nodes as off-board sensors. This system could permit a UUV to continue transit at

147 McMullen, Teresa. *Compact Rapid Attack Weapon (CRAW)*. Arlington: 2009.

148 McMullen 6.

programmed speed and depth and still be able to communicate through Seaweb to a command center or even an aircraft.¹⁴⁹

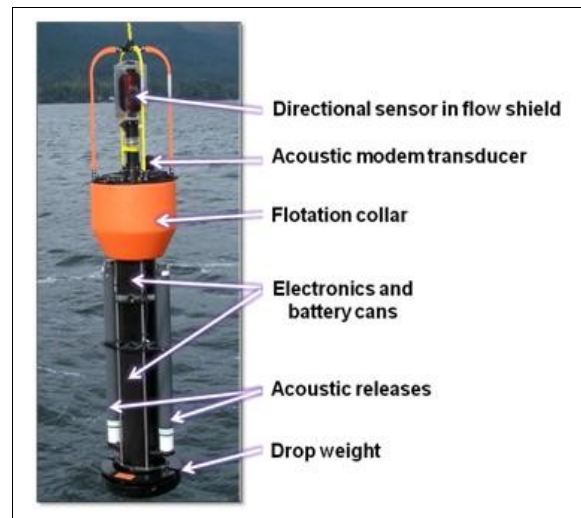

Figure E.5: Seaweb Buoy¹⁵⁰

AUWS will need to have the capability to communicate a maritime Combined Operational Picture (COP) to combatant commanders, task force commanders, or ships and squadrons operating in the local area. Communication needs to be effective and efficient. If AUWS needs to wait for an engagement order, then the system needs to sense, identify, communicate the COP, request a firing order, as well as receive that order in a matter of minutes, all before the threat is outside a predetermined engagement window. Gateway nodes, such as those used in Seaweb, are one means of providing sufficient information flow.

Unmanned Underwater Vehicles: Recently, UUVs have been at the forefront of future undersea technological development. UUVs are considered viable solution for AUWS, provided that they can address the critical need areas and perform the critical functions identified in this analysis. Some of those UUV systems include the Navy-sponsored Seahorse Autonomous Underwater Vehicle (AUV) at the Penn State Applied Research Lab, the Columbia Group's Long Duration Large Diameter (L2D2) UUV, as well as many other programs by major defense contractors like Boeing, Lockheed Martin, and Northrop Grumman.

The Seahorse, Figure E.6, is a 38 inch diameter AUV powered with alkaline batteries. It is able to operate for over 100 hours at a sustained speed of four knots, and a sprint speed of six knots. It uses onboard sonar and GPS navigation. The Seahorse can communicate via RF, Iridium satellite, and acoustic modem. Command and control systems allow for pre-programmed operations from either ship or shore.¹⁵¹

149 Honegger, Barbara. NPS Pioneers "Seaweb" Underwater Sensor Networks. 2010.

<<http://www.nps.edu/About/News/NPS-Pioneers-Seaweb-Underwater-Sensor-Networks.html>>.

150 Rice, Joseph. Seaweb. Monterey: Naval Postgraduate School, 2010.

151 Galambos, James. P. Advanced Technology, Applied Research Lab, Pennsylvania State University. 2009.

<<http://www.arl.psu.edu/capabilities/at.html>>.



Figure E.6: Seahorse AUV¹⁵²

The L2D2, Figure E.7, is a 60 inch diameter diesel-electric hybrid UUV. Working with NSWC Panama City Division, the Columbia Group is developing this UUV based on a modified body of a Seal Delivery Vehicle. It is designed to operate at speeds up to 6 knots and with ranges up to 900 nautical miles. This larger UUV has multiple weapon payload configurations as well as sonar detection and navigation capabilities. Communication equipment includes acoustic modems and surface RF antennae.¹⁵³

152 Galambos 1.

153 Dudinsky, J. "L2D2: Large Diameter Long Duration Littoral UUV." Panama City: 2011.



Figure E.7: Prototype L2D2 Body

(left to right: RADM (ret.) Jerry Ellis, RADM (ret.) Rick Williams, LT Phil Castaneda, LT Jim Drennan, RADM (ret.) Paul Shebalin, Dr. Tim Chung)

Energy Systems: The CNO stated in 2010 a goal to develop, within 7 years, UUVs capable of operating independently for 30 days.¹⁵⁴ In support of this goal, current research is underway to extend battery life while minimizing their size, as well as potentially harness energy from the environment.

The Renewable At Sea Power (RASP) program at the Defense Advanced Research Projects Agency (DARPA) aims to develop capabilities that will enable UUVs or other sensor stations to operate continuously. The program is currently developing unmanned, un-moored buoys or platforms, capable of collecting and storing wave energy, to use as recharging stations for autonomous systems such as AUWS.¹⁵⁵ Several companies have candidate technologies already in production. Ocean Power Technologies makes power generating buoys rated at 150 kW, and has a 500 kW version in development.¹⁵⁶

In addition to DARPA, military contractors like Boeing, Lockheed Martin, and Northrop Grumman, are investing millions of dollars towards solving the energy concerns of the Navy. Specific areas of focus include high capacity batteries, fuel cells, and diesel-electric hybrids.

154 Standifer, C. "CNO Wants 30-Day Mission in Seven Years." *Inside the Navy*. 22 Oct. 2010.

155 DARPA. "Renewable at-sea power." <http://www.darpa.mil/Our_Work/STO/Programs/Renewable_At-Sea_Power.aspx>.

156 Ocean Power Technologies. (n.d.). "PB150 PowerBuoy." *OceanPowerTechnologies.com*. 20 May 2011. <<http://www.oceanpowertechnologies.com/pb150.htm>>

MK-46 Performance Numbers:¹⁵⁸ Range approx, 10000 yards @ 45 knots
 Equivalent to, 9140m @ 23 m.s⁻¹

Calculations: $Reynold's\ no. = Re = \frac{\rho V L}{\mu}$; $Drag\ Force, F_D = \frac{1}{2} \rho A C_d V^2$;

Power needed to overcome drag, $P_d = F_D * V$;

Table F.1: Power Calculations for Various Speeds

Speed, knots	Speed, V, m/s	Reynolds No.	Drag Coefficient, Cd	Drag Force, F _D , N	Power needed, P _d , kW
45	23.0	5.95 E 7	0.2 (estimated from Figure F.1)	4224	97.2
20	10.0	2.66 E 7		798	8.0
10	5.0	1.32 E 7		200	1.0
5	2.6	0.67 E 7		54.0	0.14

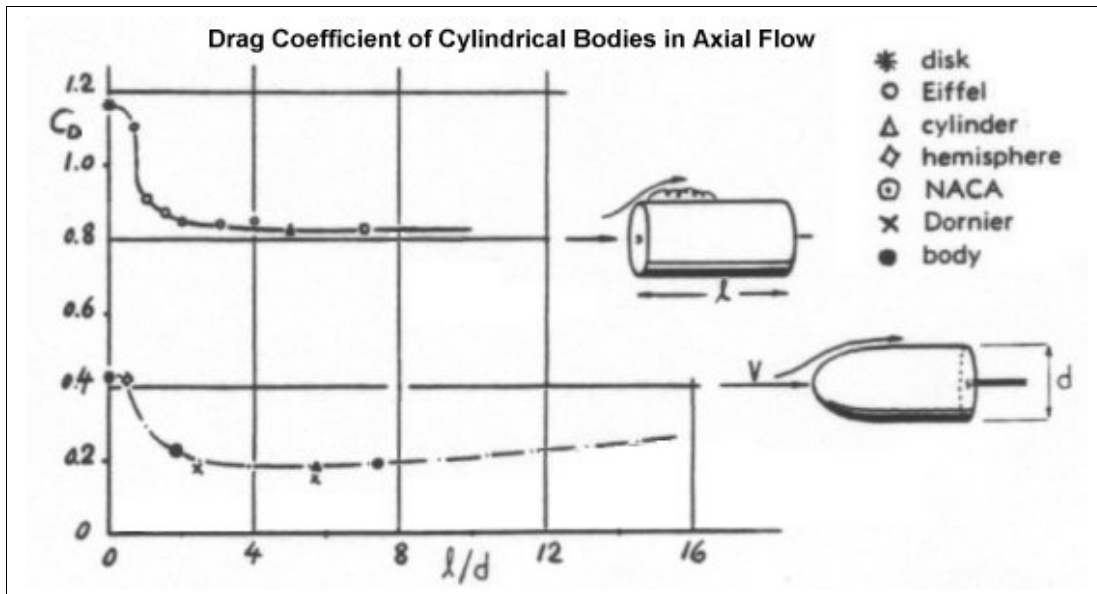

Figure F.1: Drag Coefficients of Cylindrical Bodies in Axial Flow¹⁵⁹

Total energy expended by torpedo to travel 10000 yards @ 45 knots is,

$$W_d = P_d \cdot \frac{Dist.}{V} = 97200 * \frac{9140}{23} = 38.6MJ$$

Most of the energy in the fuel tank is expended to keep the torpedo at 45 knots in water for 10000 yards, hence assume the energy required to power the guidance & control systems as well as the initial energy required to accelerate the torpedo to cruise speed as relatively small,

≈ 5% of $W_d = 1.9MJ$. Therefore total energy stored in the fuel tank,

$$W_{tot} \approx W_d + 1.9MJ = 40.5MJ$$

¹⁵⁸ IHS Global Limited 1.

¹⁵⁹ Hoerner, Sighard. Fluid Dynamic Drag. Brick Town: Hoerner Fluid Dynamics, 1965.

Mk-46 fuel tank is approximately half the body length.¹⁶⁰

In order to create space for operational requirements, only 1/10 of the space in V-CAP is available for propulsion. Therefore total chemical power available for the V-CAP system =

$$W_{tot} \div \frac{1}{2} * \frac{1}{10} = 8.1MJ.$$

Calculating for theoretical max range at different speeds, $R_{max} = \frac{W_{avail}}{P_d} * V$

Table F.2 shows range calculations for various speeds.

Table F.2: Range Calculations for Various Speeds

Speed, knots	Power needed, P _d , kW	Total Energy, W _{tot} , MJ	Energy Available, ¹⁶¹ W _{avail} , MJ	Max Range, R _{max} , NM
20	8.0	8.1	6.2	15.5
10	1.0			62.0
5	0.14			221.4

LD-UUV Endurance

Area is the cross sectional area of the vehicle, modeled as a circle of given diameter. Time in operation is the time required to travel the given distance with the given speed. Power draw is the number of watts required to power the system during maneuvering operations, given as the drag equation for force¹⁶² multiplied by velocity. Effectively, power is equal to one-half of the product of the coefficient of drag, density of seawater, cross-sectional area of the unit, and the cube of the unit's speed.

$$Power = \frac{C_d \rho A v^3}{2}$$

From this calculation comes a value in watts, meaning that for every watt required, the system will require that many joules of energy for every second of operation. Given the time in seconds previously calculated, a total number of joules required for propulsion and maneuvering is obtained.

$$Power = 0.5 * 0.2 * 1030 \frac{kg}{m^3} * 3.243m^2 * \left(2.57 \frac{m}{s}\right)^3 = 5.67kW$$

$$Energy = Power * Time = 5.67kW * 9.3681x10^4sec = 531.16 MJ$$

Sensor capacity is the number of joules required to operate the system's sensors and communications suites for a 30-day period. By multiplying the estimated sensor and

¹⁶⁰ The Ordnance Shop. "MK 46 TORPEDO." *ordnance.org*. 3 May 2011
<http://www.ordnance.org/mk_46_torpedo.htm>.

¹⁶¹ Assuming that the same amount of energy is expended to power guidance, control systems as well as to accelerate the torpedo up to speed, regardless of the speed it had to accelerate to, the energy available would therefore be W_{tot} less 1.9MJ.

¹⁶² Benson, 2010.

communications draw (0.375 W) by 30 days, or 2,592,000 seconds, a value of 972 kJ is reached. This value plus the joules required to provide propulsion equal the total draw on each LD-UUV's energy store (532.13 MJ).

To determine the capacity of LD-UUV's battery, the mass is calculated by multiplying the cross sectional area by the length of the unit to develop a total volume, then multiplying that volume by the density, assumed to be equivalent to a Mk-48 ADCAP. Given a battery percentage of 20%, a battery comprising approximately one-fifth of the total mass is estimated. The LD-UUV battery weight is multiplied by the lithium ion energy density to determine system capacity in joules.

$$\text{Mass} = \text{Volume} * \text{Density} = (3.243\text{m}^2 * 5.7912\text{m}) * \left(1298 \frac{\text{kg}}{\text{m}^3}\right) = 24,377\text{kg}$$

$$\begin{aligned} \text{Energy Capacity} &= \text{Energy Mass} * \text{Energy Density} = (0.2 * 24,377\text{kg}) * (460 \text{kJ/kg}) \\ &= 2.242\text{GJ} \end{aligned}$$

Dividing the sum of propulsion and sensor draw by total battery capacity provides a fraction indicative of the portion of battery capacity expended over a 30-day operation. Dividing 30 days by this percentage gives a theoretical number of days required to expend the battery completely.

$$\% \text{ Battery Expended (30 days)} = \frac{532.13\text{MJ}}{2.242\text{GJ}} = 23.7\%$$

$$\text{Theoretical Endurance} = \frac{30}{0.237} = 126.436 \text{ days}$$

Glider Maximum Intercept Range

Equations are taken from Eagle's Approaching Target Model,¹⁶³ illustrated in Figure F.2.

¹⁶³ Eagle, James. Naval Tactical Analysis Lecture Notes. Monterey: Naval Postgraduate School, 2009.

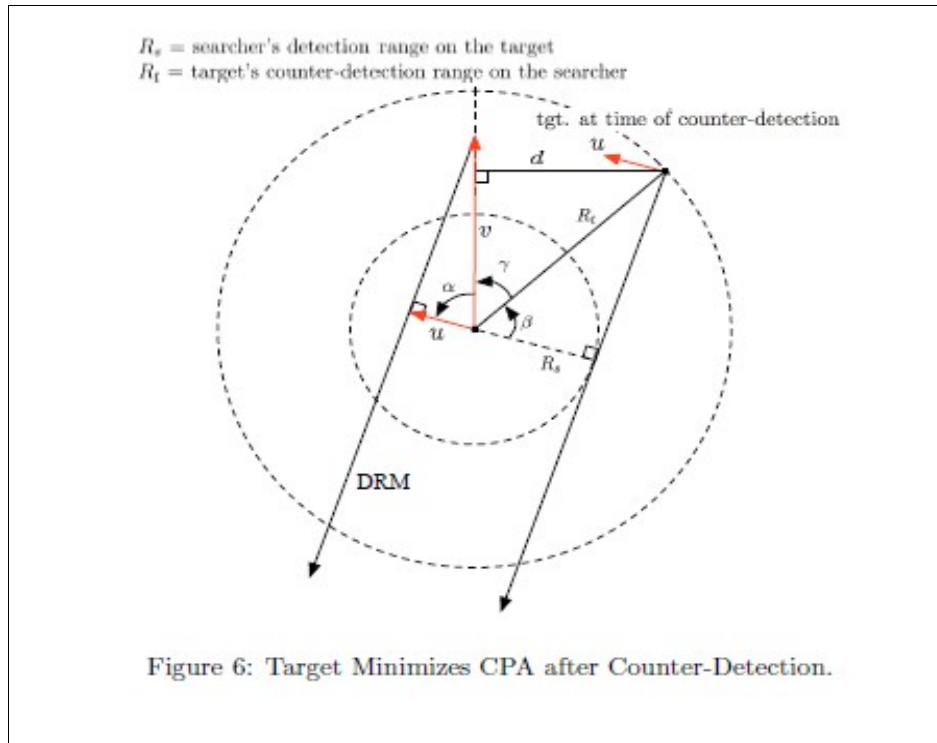

Figure F.2: Approaching Target Model

Given: d : Glider maximum distance off Target track
 R_i : Glider distance to Target at start of intercept
 R_s : Range at intercept (assume = 0)
 U : Glider speed
 V : Target speed

$$d = R_t \sin \left(\pi - \cos^{-1} \left(\frac{U}{V} \right) - \cos^{-1} \left(\frac{R_s}{R_t} \right) \right)$$

Assuming a Glider speed of 2 knots, Target speed of 15 knots, and a zero R_s ,

$$d = R_t \sin \left(\pi - \cos^{-1} \left(\frac{2}{15} \right) - \frac{\pi}{2} \right)$$

$$d = R_t \sin(0.1337) = 0.1333R_t$$

R_t is estimated by determining the an initial detection point and the distance the Target is able to travel before the engagement order reaches the prosecuting Glider. Assuming best case (which leads to a minimal estimate of # Gliders required), the Target is detected 2.7 NM before it reaches the AOR. Allowing for one minute of processing and an approximate six minutes for communication time, based on Glider's baseline data rate, the Target travels 1.75 NM before intercept begins. Therefore,

$$R_t = \sqrt{((2.7 + 3) - 1.75)^2 + d^2}$$

$$R_t = \sqrt{3.95^2 + d^2}$$

Combining this with the previous equation,

$$d = 0.1333\sqrt{3.95^2 + d^2}$$

Solving for d yields, d = 0.53 NM. Adding a nominal 5% increase for terminal maneuvering boost, the maximum intercept range is estimated at 0.55 NM.

Weapon Model

Calculations for all weapons are taken from Shin's Ship Shock Model.¹⁶⁴ All weapons are assumed to use HBX-1 explosive.

Given: P(t): pressure from shock wave caused by underwater explosion, as a function of time

P_{max}: peak overpressure

W: weight of explosive

R: range to target at time of detonation

A₁, K₁: parameters specific to HBX-1 explosive

A₁ = 1.144

K₁ = 22347.6

$$P_{\max} = K_1(W^{1/3}/R)^{A_1} \text{ psi}$$

For each intercept, a random value of R is generated between 0 and 5 feet. The resulting P_{max} is compared to the tensile strength of the target hull, which is randomly generated between 55 and 70 ksi. If P_{max} exceeds the tensile strength of the hull, prosecution is successful.

Sensor Model (Attempted)

The Probability of Detection, P_d, is determined using the expressions¹⁶⁵ as shown below. The idea is to model the target and noises as a form of voltage, A and V_o respectively. For instance, high voltage is to represent good detection, i.e. noisy target or target in near vicinity. The threshold voltage, V_T, varies according to the sensor's operating threshold.

System Noise:

$$P_N(V) = (V / V_0^2) e^{-V^2 / 2V_0^2}$$

¹⁶⁴ Shin, Young S. Ship shock modeling and simulation for far-field underwater explosion. Monterey: Elsevier Ltd., 2002.

¹⁶⁵ Harney, Robert C. "Sensor Functional Characteristics. Vol. 1." Harney, Robert C. Combat Systems. Monterey: Naval Postgraduate School, 2004. 335-340.

P(False Alarm):
$$P_F = \int_{V_T}^{\infty} dV p_N(V) .$$

Signal + noise:
$$p_{S+N}(V) = (V / V_0^2) e^{-(V^2 + A^2)/2V_0^2} I_0(VA / V_0^2)$$

P(detection):
$$P_D = \int_{V_T}^{\infty} dV p_{S+N}(V)$$

The following assumptions are made to supplement the P_d plot:

- Assume the deployed sensor as a typical hydrophone with maximum detection range of up to 3km.
- Assume target will move across the sensor in a systematic (or linear) way.
- Assume ambient noise of 70dB which corresponds to sensor operating at center frequency of 200Hz in heavy shipping traffic and sea state 3.¹⁶⁶
- Assume system noise is small as compared to the ambient noise.
- Assume noise is constant within a 3km radius of the sensor.

The expressions were generated in MATLAB and a sample plot, shown in Figure F.3, of P_d against Range was obtained using arbitrary values – target voltage, $A = 50$, threshold voltage, $V_T = 80$ and noise voltage, $V_o = 70$, to simulate the sensor operating in a moderately noisy environment. The resultant P_d was surprisingly low compared to currently available technology, and no explanation could be found. Further verification of this model is recommended to determine the root of the error.

166 United States Naval Academy. "Ambient Noise: The background noise of the sea." *USNA.edu*. 13 May 2011
<<http://usna.edu/Users/physics/ejtuchol/Chapter11.pdf>>.

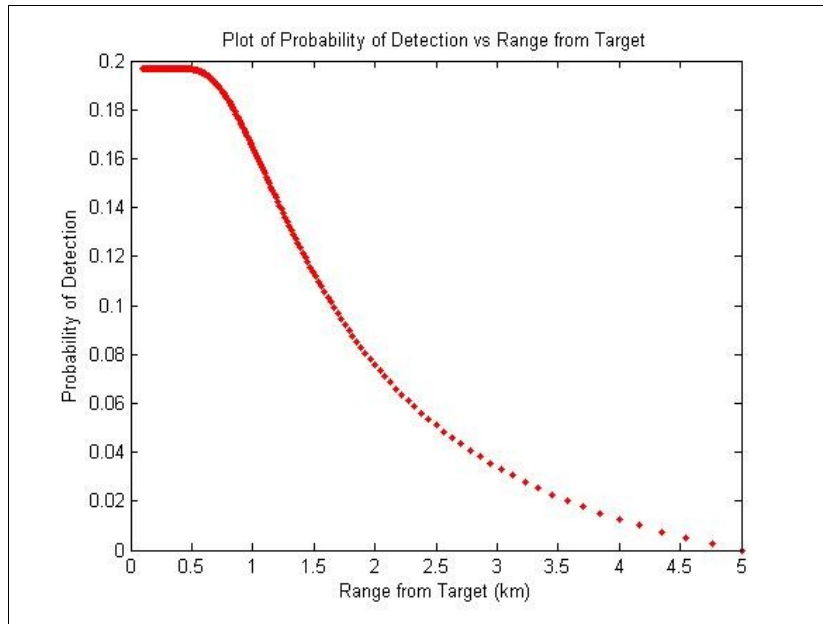

Figure F.3: P_d as a Function of Range of CPA (Attempted Model)

Figure F.4 shows the sensor profile ultimately used as the input to the system models. P_d is generated from the following function of Range of CPA (R , in meters):

$$P_d = 0.9e^{\left(-\frac{R}{k_n \cdot 10}\right)}$$

Where k_n is a sensor parameter based on the capabilities of each system:

- $k_1 = 5$ (Squid)
- $k_2 = 7.5$ (LD-UUV)
- $k_3 = 10$ (V-CAP)
- $k_4 = 10$ (Glider)

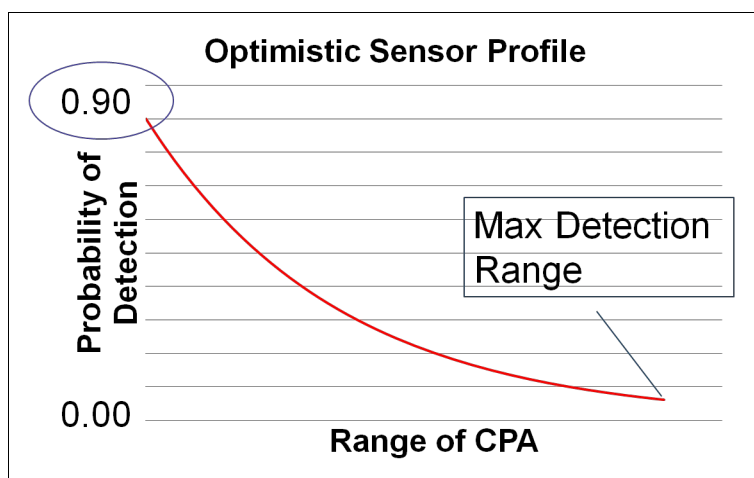

Figure F.4: P_d as a Function of Range of CPA (Optimistic)

Appendix G: Discrimination Analysis

Threat discrimination – the ability for AUWS to autonomously tell the difference between a threat and a non-threat – is considered separately from modeling and simulation because an effective analysis would likely require writing the actual algorithms for making threat determinations based on sensor data. Instead, a similar system is analyzed: IBM’s Watson, the computer that competed and won on *Jeopardy!*.¹⁶⁷



Figure G.1: IBM’s Watson Competing on *Jeopardy!*

Discrimination is essentially the ability to make a good decision. Watson makes a decision on whether or not to buzz in based on a “buzz threshold” (represented by the vertical white line in Figure G.1), which is constantly re-calculated based on the present situation. In a similar way, AUWS would decide whether or not to designate a contact as a threat and engage it. *Jeopardy!* is an appropriate game to compare to the USW scenario space because they both involve confusing, ambiguous, and often unpredictable inputs.

In order to compare Watson to AUWS, a “flip” is necessary. Considering the scenario used in modeling and simulation, most inputs received by AUWS are *non-threats*, likewise most of the inputs received by Watson are *known answers*. So, a threat for AUWS is like an answer that Watson doesn’t know. Similarly, Watson not buzzing in is like AUWS engaging. If Watson doesn’t buzz in for an answer that it knows,¹⁶⁸ that is equivalent to AUWS engaging a friendly contact.

During the *Jeopardy!* game, Watson didn’t know 25% of the answers, which would mean 25% of all contacts were actual threats for AUWS. This is a higher threat occurrence rate than modeled, but not an unreasonable one for wartime operations. Watson guessed incorrectly 8% of the time, equivalent to AUWS letting a threat pass by. Watson knew the correct answer but chose not to buzz in 6% of the time, equivalent to AUWS engaging a non-threat. In other words, 10 of 90 non-threats were engaged by a computer the size of ten refrigerators (shown in Figure G.2).

¹⁶⁷ *Jeopardy!* Dir. Kevin McCarthy. Sony Pictures Television. 2011.

¹⁶⁸ On-screen presentation of Watson’s top three guesses allows the viewer to determine Watson knows an answer. If the top guess is correct, Watson knows the answer.

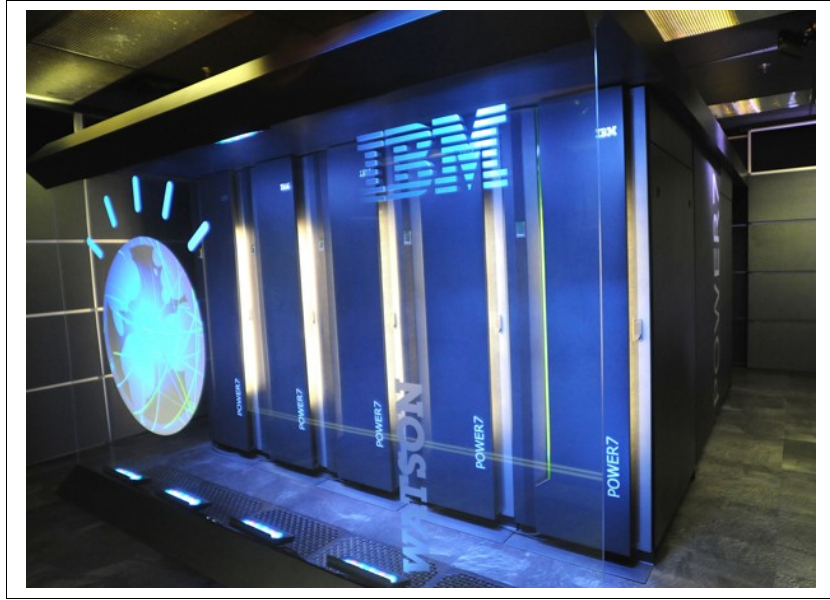

Figure G.2: Watson Server Racks (10 total)¹⁶⁹

Significant technological advancement is required before reaching desired discrimination capabilities in deployable computers. Even if current supercomputers were able to perform threat discrimination with desired accuracy, Moore's Law – which predicts (accurately for the last half century) that the capacity of integrated circuits will double approximately every two years¹⁷⁰ – would have to hold strong for the next 20 years. Ultimately, discrimination in autonomous weapons is not a technological issue. It is a cultural issue. Once technology matures sufficiently, ethics, politics, law, and many other factors will still govern the use of autonomous weapons. Nevertheless, striving for tactical and technical excellence is essential to prevent unintended casualties.

Regarding the four AUWS concepts, LD-UUV appears to have an advantage with respect to discrimination. Parallel processing could potentially reduce the probability of identification errors. The group based decision making process for LD-UUV's intelligent sensor nodes, shown in Figure G.3, prevents a single node from errantly identifying and engaging a friendly or neutral vessel. If each sensor is biased toward false negative (i.e. letting a threat go), it is difficult for a false positive (i.e. neutral/friendly identified as threat) to propagate through the system to the weapon.

169 Medrano, Antonio. "IBM Watson." 2011. *enr.ucsb.edu*. 13 May 2011

<http://www.enr.ucsb.edu/~medrano/CS240A/HW1/CS240A_Homework_1/CS240A_Homework_1_-_F_Antonio_Medrano.html>.

170 Intel Corporation. "A Conversation with Gordon Moore: Moore's Law." 2005. *intel.com*. 13 May 2011

<ftp://download.intel.com/museum/Moores_Law/Video-Transcripts/Excepts_A_Conversation_with_Gordon_Moore.pdf>.

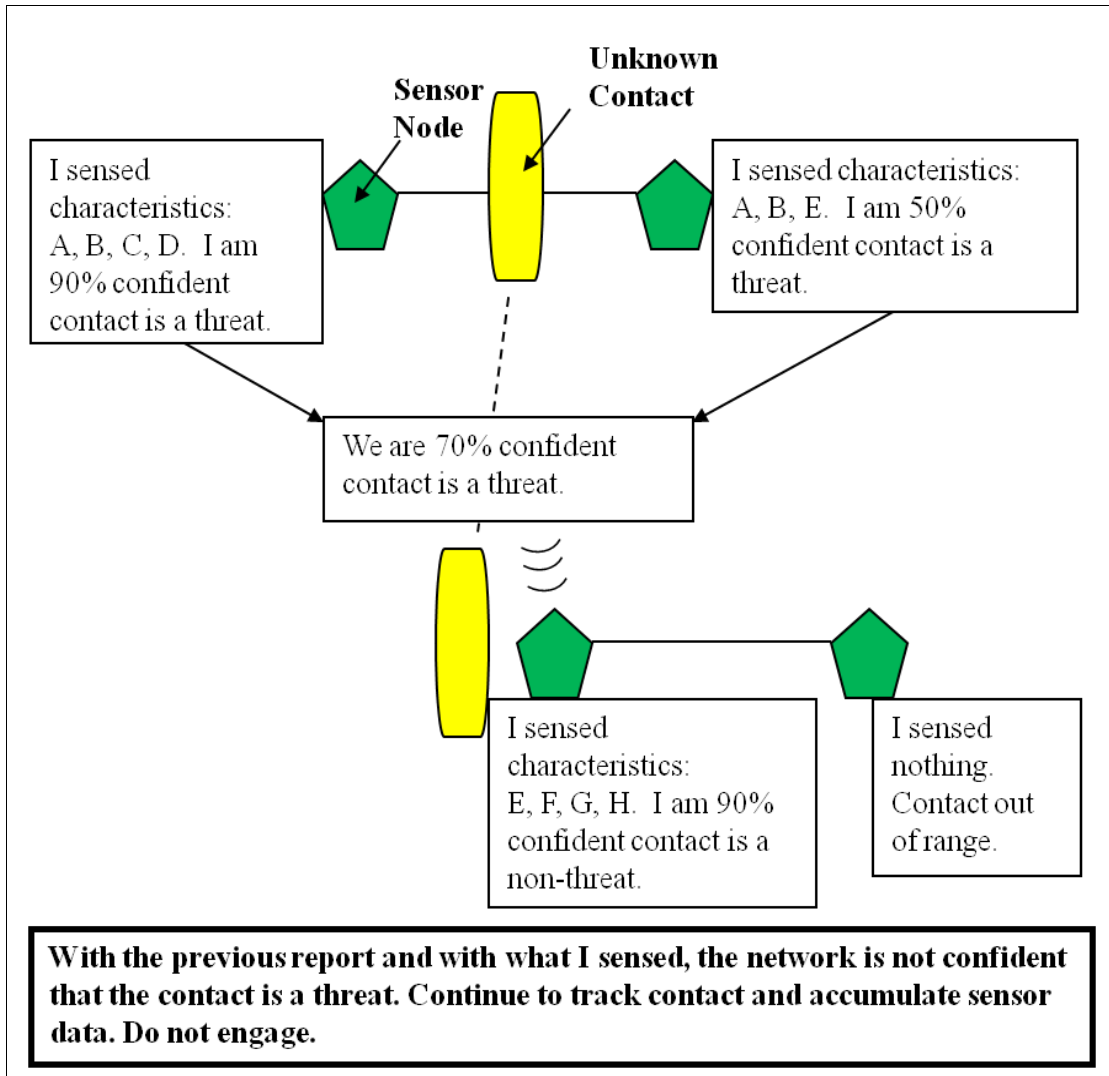

Figure G.3: Discrimination Process for LD-UUV Sensor Nodes

Appendix H: Individual Criteria Risk Considerations

The failure rates of the components listed in this appendix were utilized by the Project Team in determining the overall failure rates used in the risk analysis section. The following data points were gathered from several unclassified sources and are by no means intended to be an all inclusive list of associated probabilities.

Table H.1: Power Considerations

Concept	Components	Failure Rate of Component
V-CAP	Battery pack (Li-Ion)	1 @ 250khrs MTBF ¹⁷¹
LD-UUV	4 battery packs (Li-Ion or silver-zinc)	1 @ 250khrs MTBF ¹⁷²
Glider	Fuel Cell Technology	1080hrs/3000hrs ¹⁷³
Squid	Li-Ion Battery Technology	1 @ 250khrs MTBF ¹⁷⁴

Table H.2: C3 Considerations

Concept	Components	Failure Rate of Component
V-CAP	Underwater Modem VHF Transceiver	10 ⁻⁶ bit error rate or better ¹⁷⁵ 1.6 FITs ¹⁷⁶ (1.6x10 ⁻⁹)
LD-UUV	Buoys with acoustic communication	0.01 ¹⁷⁷ (assume proportionally to 1 failed node in a 112-node array)
Glider	Transceiver	1.6 FITs ¹⁷⁸ (1.6x10 ⁻⁹)
Squid	Acoustic Modem	10 ⁻⁶ bit error rate or better ¹⁷⁹

171 IEEE, "Lithium-Ion Batteries for Telecom Application", 2007 IEEE 23 Apr. 2011
<<http://ieeexplore.ieee.org/stamp/stamp.jsp?arnumber=04448872>>.

172 IEEE, "Lithium-Ion Batteries for Telecom Application", 2007 IEEE 23 Apr. 2011
<<http://ieeexplore.ieee.org/stamp/stamp.jsp?arnumber=04448872>>.

173 2010 Fuel Cell Seminar & Exposition, October 18-21, Richard Carlin 23 Apr. 2011
<http://www.fuelcellseminar.com/media/5502/carlin_10_19_2010.pdf>.

174 IEEE, "Lithium-Ion Batteries for Telecom Application", 2007 IEEE 23 Apr. 2011
<<http://ieeexplore.ieee.org/stamp/stamp.jsp?arnumber=04448872>>.

175 DSPCOMM. "AquaComm: Underwater wireless modem." DSPCOMM, 2007-2009 23 Apr. 2011
<http://www.dspcomm.com/products_aquacomm.html>.

176 Avago Technologies. "Reliability Data Sheet, AFCT-57J5APZ, AFCT-57J5APZ-XXX." Avago Technologies 7 Jun. 2008. 23 Apr. 2011.

177 Warren A. Rosen, and Alan D. George. "FAULT TOLERANCE CONSIDERATIONS IN AUTONOMOUS ACOUSTIC ARRAYS." Office of Naval Research.

178 Avago Technologies. "Reliability Data Sheet, AFCT-57J5APZ, AFCT-57J5APZ-XXX." Avago Technologies 7 Jun. 2008. 23 Apr. 2011.

179 DSPCOMM. "AquaComm: Underwater wireless modem." DSPCOMM, 2007-2009 23 Apr. 2011
<http://www.dspcomm.com/products_aquacomm.html>.

Table H.3: ISR Considerations

Concept	Components	Failure Rate of Component
V-CAP	Hydrophones	1 in 18,300 years ¹⁸⁰ (5.46×10^{-5})
LD-UUV	Paired Sensors	1 in 18,300 years ¹⁸¹ (assume a network of 8 pairs, $8 \times 5.46 \times 10^{-5}$)
Glider	Paired Sensors	1 in 18,300 years ¹⁸² (5.46×10^{-5})
Squid	Pressure Sensor	4.90×10^{-7} 1/hr ¹⁸³ (assume from Honeywell)
	Passive sonar sensor	1 in 18,300 years ¹⁸⁴ (5.46×10^{-5})

Table H.4: Armament Considerations

Concept	Components	Failure Rate of Component ¹⁸⁵
V-CAP	Multi-shot scaled down CRAW version with a shaped charge	Functional: 0.99 Safety: $\leq 1 \times 10^{-6}$
LD-UUV	4x Lightweight Torpedoes	Functional: 0.99 Safety: $\leq 1 \times 10^{-6}$
Glider	1x 10 kg High Explosive shaped charge	Functional: 0.99 Safety: $\leq 1 \times 10^{-6}$
Squid	6x1kg High Explosive shaped charges per node	Functional: 0.95 Safety: $\leq 1 \times 10^{-6}$

Table H.5: OPSEC Considerations

Concept	Components	Failure Rate of Component ¹⁸⁶
V-CAP	Sub-Munition Self-Neutralization Mechanism	7%
LD-UUV	Sub-Munition Self-Neutralization Mechanism	5%
Glider	Tamper-proof mechanism Cryptographic Software	0.8%
Squid	Sub-Munition Self-Neutralization Mechanism	12%

180 Digital Energy Journal. "Ocean bottom seismic – improving cost and reliability." *Digital Energy Journal* 19 Jul. 2010. 23 Apr. 2011.

<http://www.findingpetroleum.com/n/Ocean_bottom_seismic_improving_cost_and_reliability/58f46b59.aspx>.

181 Digital Energy Journal. "Ocean bottom seismic – improving cost and reliability." *Digital Energy Journal* 19 Jul. 2010. 23 Apr. 2011.

<http://www.findingpetroleum.com/n/Ocean_bottom_seismic_improving_cost_and_reliability/58f46b59.aspx>.

182 Digital Energy Journal. "Ocean bottom seismic – improving cost and reliability." *Digital Energy Journal* 19 Jul. 2010. 23 Apr. 2011.

<http://www.findingpetroleum.com/n/Ocean_bottom_seismic_improving_cost_and_reliability/58f46b59.aspx>.

183 Goble, W.M. "Getting Failure Rate Data." *Exida* 2002.

184 Digital Energy Journal. "Ocean bottom seismic – improving cost and reliability." *Digital Energy Journal* 19 Jul. 2010. 23 Apr. 2011.

<http://www.findingpetroleum.com/n/Ocean_bottom_seismic_improving_cost_and_reliability/58f46b59.aspx>.

185 Tan, Geoffrey. *Warheads*. Singapore: DSO National Laboratories, 2010. 4.

186 Hiznay, Mark. *Operational and technical aspects of cluster munitions*. Washington: Arms Division of Human Rights Watch, 2006. 20.

Table H.6: Maneuver Considerations

Concept	Components	Failure Rate of Component
V-CAP	Underwater Propulsion System: OTTO Fuel	1 in 2000hours ¹⁸⁷
LD-UUV	Underwater Propulsion System	
Glider	Underwater Propulsion System	
Squid	Dependent on Projectile Unable to move on its own.	1 in 122 hours ¹⁸⁸

187 Rowinski, Lech. "Submersible propulsion and energy." 18 Mar. 2002. *underwater.pg.gda.pl*. 23 Apr. 2011.
<http://www.underwater.pg.gda.pl/publikacje/submersible_conceptual_design_using_computer_aids.pdf>.

188 155-mm M109 SP Howitzer, Military Periscope, 1 Jun. 2009. 23 Apr. 2011.
<<http://www.periscope.ucg.com/mdb-smpl/weapons/artguns/selfprop/w0003617.shtml>>.

Appendix I: Risk Matrices

V-CAP Risk						
Likelihood	5					
	4					
	3		Cost	ISR		
	2	Schedule	OPSEC		Power	
	1	Structure	Armament Maneuver	C3		
		1	2	3	4	5
		Consequence				

LD-UUV Risk						
Likelihood	5					
	4					
	3					
	2	Schedule OPSEC		ISR Cost	Power	
	1		Armament Structure	C3 Maneuver		
		1	2	3	4	5
		Consequence				

GLIDER Risk						
Likelihood	5					
	4					
	3			ISR		
	2		C3 Structure Schedule Cost		Maneuver	
	1		Power Armament OPSEC			
		1	2	3	4	5
		Consequence				

SQUID Risk						
Likelihood	5					
	4		ISR			
	3	Maneuver		C3		
	2		Armament OPSEC	Power		
	1		Structure Schedule Cost			
		1	2	3	4	5
		Consequence				

Technical Risk						
Likelihood	5					
	4					
	3					
	2		GLIDER SQUID	VCAP		
	1			LD-UUV		
		1	2	3	4	5
Consequence						

Schedule Risk						
Likelihood	5					
	4					
	3					
	2	VCAP LD-UUV	GLIDER			
	1		SQUID			
		1	2	3	4	5
Consequence						

Cost Risk						
Likelihood	5					
	4					
	3		VCAP			
	2		GLIDER	LD-UUV		
	1	SQUID				
		1	2	3	4	5
Consequence						

Power Risk						
Likelihood	5					
	4					
	3					
	2			SQUID	VCAP LD-UUV	
	1		GLIDER			
		1	2	3	4	5
Consequence						

C3 Risk						
Likelihood	5					
	4					
	3			SQUID		
	2		GLIDER			
	1			VCAP LD-UUV		
		1	2	3	4	5
Consequence						

ISR Risk						
Likelihood	5					
	4		SQUID			
	3			VCAP GLIDER		
	2			LD-UUV		
	1					
		1	2	3	4	5
Consequence						

Armament Risk						
Likelihood	5					
	4					
	3					
	2		SQUID			
	1		VCAP LD-UUV GLIDER			
		1	2	3	4	5
		Consequence				

OPSEC Risk						
Likelihood	5					
	4					
	3					
	2	LD-UUV	V-CAP SQUID			
	1		GLIDER			
		1	2	3	4	5
		Consequence				

Maneuver Risk						
Likelihood	5					
	4					
	3	SQUID				
	2				GLIDER	
	1		VCAP	LD-UUV		
		1	2	3	4	5
		Consequence				

Structure Risk						
Likelihood	5					
	4					
	3					
	2		GLIDER			
	1	VCAP	LD-UUV SQUID			
		1	2	3	4	5
		Consequence				

Appendix J: Notional V-CAP Test and Evaluation Master Plan (TEMP)

Table of Contents

Section 1: Introduction.....	275
Purpose.....	275
System Description.....	275
Section 2: Mission Need and Operational Requirement.....	275
Mission Need.....	275
Operational Requirements.....	275
Section 3: Scope of the Evaluation.....	276
General Function and Capability Dendritics.....	277
MOE/MOP/DR.....	279
General Test Operations and Scenario Overview.....	284
Instrumentation Requirements.....	284
Limitations to Scope of Test.....	285
Section 4: Operational Effectiveness.....	287
Scenarios and Run Profiles.....	287
Example Scenario.....	287
Run Profile Timeline.....	289
Effectiveness Test 2b: Mobility (Navigational Accuracy).....	290
Objective.....	290
Procedure.....	290
Data Analysis.....	290
Effectiveness Test 6a/b: Prosecution (Engagement Rate).....	291
Objective.....	291
Procedure.....	291
Data Analysis.....	291
Effectiveness Test 7b: Lethality (Accuracy).....	291
Objective.....	291
Procedure.....	291
Data Analysis.....	291
Effectiveness Test 10a: Survivability (Detection Avoidance).....	292
Objective.....	292
Procedure.....	292
Data Analysis.....	292
Section 5: Operational Suitability.....	292
Suitability Test 1a/b: Human Factors.....	292
Objective.....	292
Procedure.....	292
Data Analysis.....	293
Suitability Test 2: Interoperability.....	293
Objective.....	293
Procedure.....	293
Data Analysis.....	293

Annex A: Resource Requirements.....	294
Annex B: Data Sheets and Questionnaires.....	295
E-2: Navigation Effectiveness Datasheet.....	295
S-1: Human Factors Questionnaire.....	296
Annex C: OMITTED.....	303
Annex D: Data Analysis Plan.....	304

Section 1: Introduction

Purpose

This Test and Evaluation Master Plan (TEMP) has been written in support of the new development program for the Advanced Underwater Warfare System (AUWS).

System Description

AUWS will integrate deploying assets and controlling assets in order to effectively monitor, engage, and/or neutralize a target or threat. It will be capable of being deployed from airborne, surface, sub-surface, and shallow water shore locations. The system consists of dual torpedo-shaped vehicles that act as an autonomous ISR and engagement platform. AUWS will serve as a deterrent by posing the threat of area denial to an adversary, potentially forcing a change in operations and the expenditure of significant resources. The system will also be capable of protecting friendly assets in port or at sea from mines or any other asymmetric threat, including adversary submarines. The two units are deployed in tandem, transit to their assigned area, lay a sensing communications node network, and take station. The first unit deploys sonar, electro-optical, and communications arrays and serves as an intelligence-gathering command station, while the second unit stands by to launch like a torpedo or deploy sub-munitions, depending on warhead payload.

Section 2: Mission Need and Operational Requirement

Mission Need

As the face of Naval Warfare has continued to change the need for a viable system capable of creating and sustaining an underwater operational picture of interest has become clear: The Navy needs an unmanned, non-platform-centric USW system to provide ISR and threat engagement capability in littoral areas of interest. The system should be capable of operations under varying levels of autonomy, such that it can seamlessly shift from fully autonomous operations to remote manual operations and provide the Navy with a cost-effective—yet technologically advanced—solution to bridge the widening capability and capacity gap in the underwater domain.

Operational Requirements

1. AUWS shall be capable of operating independently of a tending asset for at least thirty days.
2. AUWS must have an adjustable autonomy feature that allows a controlling station to authorize fully autonomous operations or completely manual operations via remote control or any posture in between.
3. AUWS must have a continuous two-way communications capability between distributed components and tending/controlling/launching assets.

4. AUWS must be capable of searching, detecting, tracking, and classifying contacts via organic sensors and processing.
5. AUWS must be capable of conducting Intelligence, Surveillance, and Reconnaissance missions.
6. AUWS must be capable of correctly discriminating between contacts of interest and regular contacts.
7. AUWS must be capable of kinetically engaging a target as needed/directed.
8. AUWS must be capable of deployment from airborne assets (P-8, F/A-18), surface assets and subsurface assets (SSN/SSBN/SSGN/LD-UUV).
9. AUWS must be capable of recovery by surface assets and subsurface assets (SSN/SSBN/SSGN).
10. AUWS must be capable of transit from covert launch insert point to 100 NM.
11. AUWS must be rapidly deployable via air-drop.
12. AUWS must be capable of avoiding detection by enemy assets.
13. AUWS must be capable of self-neutralization in the event of compromise or the inability to be recovered.
14. AUWS shall be capable of operating at a depth of 500 ft.
15. AUWS shall have an operational availability of 0.95 when in standby for launch.
16. AUWS shall have an operational availability of 1.0 when on station for the first thirty days.

Section 3: Scope of the Evaluation

Table J.1: Critical Technical Parameters

	Technical Parameter	Measurement
1	Range	100 NM from delivery vehicle 10 NM within operating area
2	Endurance	Minimum Days Deployed = 30 days
3	Mobility	Max Speed (Deployment Phase) = 5 kts Max Speed (On Station) = 3 kts Max Speed (Weapon Delivery Phase) = 40 kts
4	Weight	Max Weight (Gross Weight) = 2000 lbs
5	Size/Cube	Max Length = 146" Max Width = 21"
6	Energy Efficiency	Average Hullform Efficiency = 70% Average Battery Life = 75 hours
7	Recharge Ability	Average Recharge Rate = 1% per hour
8	Detect-to-Engage	5 mins
9	Transportability	Air delivery from fixed wing assets (P-8) Surface delivery and recovery from any surface vessel equipped with davit system Sub-surface delivery and recovery from undersea assets (SSN/SSBN/SSGN)
10	Reliability	Mean-Time-To-Repair (MTTR) < 24 hours Mean-Time-Between-Failure (MTBF) > 30 days

General Function and Capability Dendritics

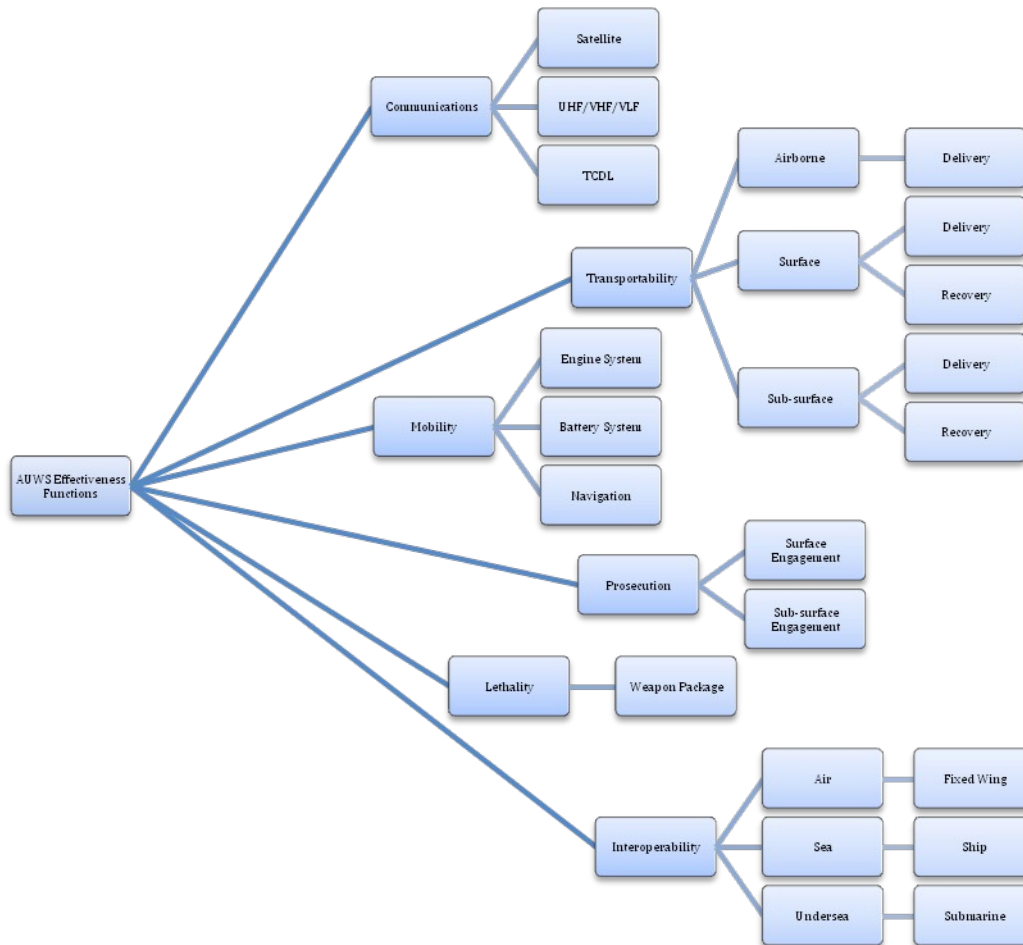

Figure J.1: Master Functional Dendritic

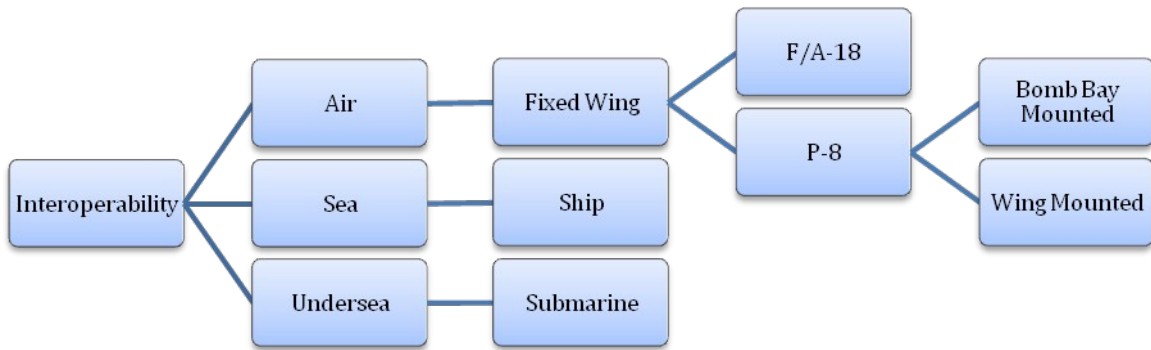

Figure J.2: Partial Dendritic for Capability

Table J.2: Critical Operational Issues

COI #	Title	Question
1	Endurance	Can AUWS operate tactically for a minimum of 30 days?
2	Mobility	Is the mobility of AUWS sufficient for accomplishment of its combat mission in varying terrain and environmental conditions?
3	Computability	Is the computing capability of AUWS robust enough to maintain varying levels of autonomy?
4	Target Detection	Is AUWS capable of detecting targets in a timely manner?
5	Classify	Is AUWS capable of accurately classifying targets in a timely manner?
6	Prosecution	Does AUWS have the capability to effectively engage threat systems?
7	Lethality	Is the lethality of AUWS sufficient to destroy, defeat, or disrupt an adversary target of interest?
8	Employment	Are the tactics developed for AUWS for deter and engage targets scenarios effective?
9	Transportability	Can AUWS be deployed and recovered from multiple platforms?
10	Survivability	Can AUWS satisfactorily survive in various operating environments?
11	Human System Integration	Is AUWS user friendly and safe for human involvement?
12	Interoperability	Will AUWS be interoperable with existing platforms and systems currently employed?

MOE/MOP/DR

- COI 1 – Endurance
 - MOE 1.1 Capability to Operate for Minimum of 30 Days
 - MOP 1.1.1 Proportion of Power Required for Mission Profile
 - MOP 1.1.2 Rate of Fuel Consumption
 - DR 1.1.2.1 Number of Gallons per Hour Used
 - MOP 1.1.3 Average Electrical Power Requirement
 - MOE 1.2 Capability to Recharge
 - MOP 1.2.1 Rate of (Re)Charge
 - MOP 1.2.2 Average Time System Unavailable
 - MOE 1.3 Capability to Store Energy
 - MOP 1.3.1 Average Capacity of Battery
 - MOP 1.3.2 Rate of Discharge
- COI 2 – Mobility
 - MOE 2.1 Capability to Maneuver
 - MOP 2.1.1 Rate of Speed
 - MOP 2.1.2 Average Speed for Conditions
 - MOE 2.2 Navigation
 - MOP 2.2.1 Average Maneuver Error
 - MOP 2.2.2 Average Location Error
 - DR 2.2.2.1 Known location of System
 - DR 2.2.2.2 System's determined location
 - MOP2.2.3 Average Error for Self-location
- COI 3 – Computability
 - MOE 3.1 Probability of Successful Command Automation
 - MOP 3.1.1 Proportion of Transmitted Data sets correctly processed
 - DR 3.1.1.1 Total number of data sets processed correctly
 - DR 3.1.1.2 Total number of data sets processed
 - MOE 3.2 Average Speed of Processing
 - MOP 3.2.1 Proportion of Retrieved Data Elements Correctly Processed
 - MOE 3.3 Capability to Change Level of Autonomy
- COI 4 – Target Detection
 - MOE 4.1 Probability of Target Detection
 - MOP 4.1.1 Proportion of Detections
 - DR 4.1.1.1 Number of Targets Presented
 - DR 4.1.1.2 Number of Detections
 - MOP 4.1.2 Average Range of Detection
 - MOP 4.1.3 Average Time from Target Presentation to Detection
 - MOE 4.2 Probability of Correct Target Classification

- MOP 4.2.1 Proportion of Classification
 - MOP 4.2.2 Average Range of Classification
 - MOP 4.2.3 Average Elapsed Time from Target Detection to Classification
 - MOE 4.3 Probability of Target Recognition
 - MOP 4.3.1 Proportion of Correct Recognitions
 - MOP 4.3.2 Average Range of Recognition
 - MOP 4.3.3 Average Time from Target Recognition to Classification
- COI 5 – Classify
 - MOE 5.1 Probability of Correct Target Classification
 - MOP 5.1.1 Proportion of Correct Classifications
 - DR3.3.1.1: Number of Correct Classifications
 - DR3.3.1.2: Number of Incorrect Classifications
 - MOP 5.1.2 Average Range of Classification
 - MOP 5.1.3 Average Elapsed Time from Target Detection to Classification
- COI 6 – Prosecution
 - MOE 6.1 Probability of Successful Engagement
 - MOP 6.1.1 Average Range of Engagement
 - MOP 6.1.2 Proportion of Engagements Completed
 - MOP 6.1.3 Reasons for No Engagement
 - MOE 6.2 Probability of Timely Engagement
 - MOP 6.2.1 Engagement Rate
 - MOP 6.2.2 Hit Rate
 - MOP 6.2.3 Kill Rate
 - MOE 6.3 Probability of Effective Engagement
 - MOP 6.3.1 Proportion of Hits versus Presentation
 - DR 3.3.1.1 Number of Target Hits
 - DR 3.3.1.2 Number of Target Presentations
 - MOP 6.3.2 Average Hit Range
 - MOP 6.3.3 Proportion of Target Kills versus Engagements
- COI 7 – Lethality
 - MOE 7.1 Probability of Weapon Timeliness
 - MOP 7.1.1 Average Time from Target Presentation to Hit
 - MOP 7.1.2 Average Time Between Rounds
 - MOE 7.2 Probability of Weapon Accuracy
 - MOP 7.2.1 Proportion of Rounds Meeting Stated Accuracy
 - MOP 7.2.2 Proportion of Hits versus Engagements
 - MOE 7.3 Probability of Weapon Effectiveness
 - MOP 7.3.1 Average Hit Range
 - MOP 7.3.2 Average Burst Radius
 - MOP 7.3.3 Proportion of Target Kills versus Target Engagements
 - DR 7.3.3.1 Number of Target Kills

- DR 7.3.3.2 Number of Target Engagements
- COI 8 – Tactical Employment
 - MOE 8.1 Probability of Correct Target Prioritization
 - MOP 8.1.1 Time from Classification to Prioritization
 - MOP 8.1.2 Average Range of Prioritization
 - MOP 8.1.3 Average Time from Identification to Prioritization
 - MOE 8.2 Probability of Successful Employment of Decoy
 - MOP 8.2.1 Average Success of Decoy
 - DR 8.2.1.1 Number of Decoys Utilized
 - MOE 8.3 Probability Threat Retreats
- COI 9 – Transportability
 - MOE 9.1 Capability for Deployment and Recovery by both Contemporary and Future Platforms
 - MOP 9.1.1 Proportion of System Compatibility with Existing Platforms, Systems and Subsystems
 - DR 9.1.1.1 Number of Compatible Airborne Assets
 - DR 9.1.1.2 Number of Compatible Surface Assets
 - DR 9.1.1.3 Number of Compatible Sub-surface Assets
 - MOE 9.2 Capability for Rapid Employment
 - MOP 9.2.1 Average Time to Employ
 - MOE 9.3 Capability for Rapid Recovery
 - MOP 9.3.1 Average Time to Recover
- COI 10 – Survivability
 - MOE 10.1 Detection Avoidance
 - MOP 10.1.1 Detection Avoidance Proportion
 - MOP 10.1.2 Detection Survivability Ratio
 - MOE 10.2 Situation Awareness
 - MOP 10.2.1 Threat False Alarm Rate
 - DR 10.2.1.1 Number of Alarms
 - DR 10.2.1.2 Number of Actual Threats
 - MOP 10.2.2 Target resolution
 - MOE 10.3 Acquisition Avoidance
 - MOP 10.3.1 Acquisition Survivability Ratio
- COI 11 – Human System Integration
 - MOE 11.1 Human Factors Engineering
 - MOP 11.1.1 Listing of maintainability problems and assigned impact rating by severity rating
 - DR 11.1.1.1 List of maintainability problems
 - MOP11.1.2: Listing of Workspace Adequacy Problems and their Degree of Severity
 - MOE 11.2 Human Factors Safety/Health Hazards

- MOP11.2.1 Listing of Safety Health Hazards Rated by Code IAW MILSTD-882
- COI 12 – Interoperability
 - MOE12.1 Capability to Communicate
 - MOP12.1.1: Call Completion Rate
 - DR12.1.1.1 Number of Message Attempts
 - DR12.1.1.2 Number of Messages Completed
 - DR12.1.1.3 Number of Messages Interfered
 - MOP12.2.2 Average Data Rate
 - MOE12.2 Capability to Transmit Message
 - MOP12.2.1 Proportion of Files Transferred
 - MOP12.2.2 Average Data Message Completion Time
 - MOE12.3 Capability to Receive Message
 - MOP12.3.1 Proportion of Uninterrupted Communications
 - MOP12.3.2 Message Accuracy
 - MOP12.3.3 Message Complete Rate

Table J.3: Test Objective Matrix

COI	Test Objective and Sub-Objectives	Test
Endurance	To determine the capability for AUWS to operate tactically for a minimum of 30 days	E-1
Mobility	To determine the tactical mobility of AUWS <ul style="list-style-type: none"> • Speed of AUWS (E-2a) • Navigation Accuracy (E-2b) 	E-2
Computability	To determine the capability of the AUWS computer system <ul style="list-style-type: none"> • Automation (E-3a) • Processing Speed (E-3b) • Level of Autonomy (E-3c) 	E-3
Target Detection	To determine the target detection capability of AUWS during an attack mission <ul style="list-style-type: none"> • Target Detection (E-4a) • Target Identification (E-4b) 	E-4
Classify	To determine the classification capability of AUWS during a combat mission <ul style="list-style-type: none"> • Target Classification 	E-5
Prosecution	To determine the ability of AUWS to prosecute enemy threats <ul style="list-style-type: none"> • Engagement Rate Against One Target (E-6a) • Engagement Rate Against Multiple Targets (E-6b) 	E-6
Lethality	To determine the sufficiency of lethality of the firepower of AUWS in performance of its combat mission <ul style="list-style-type: none"> • Timeliness of Fires (E-7a) • Accuracy of Fires (E-7b) • Effect of Fires (E-7c) 	E-7
Employment	To determine the tactics of AUWS during a combat mission <ul style="list-style-type: none"> • Target Prioritization (E-8a) • Decoy Employment (E-8b) 	E-8
Transportability	To determine the capability of AUWS to be deployed and recovered from multiple platforms <ul style="list-style-type: none"> • Deployment Time (E-9a) • Recovery Time (E-9b) 	E-9
Survivability	To determine the survivability of AUWS <ul style="list-style-type: none"> • Detection Avoidance (E-10a) • Threat False Alarm Rate (E-10b) • Acquisition Avoidance (E-10c) 	E-10
Human System Integration	To determine the user friendly capability and the safety of AUWS <ul style="list-style-type: none"> • Human Factors Engineering (S-1a) • Safety/Health Hazards (S-1b) 	S-1
Interoperability	To determine the ability of AUWS to interact with existing platforms and systems currently employed <ul style="list-style-type: none"> • Data Interchange 	S-2

General Test Operations and Scenario Overview

- Scenario A: ISR in a Strategic Chokepoint. AUWS is tasked with detecting and classifying traffic in a strategic chokepoint. AUWS will be responsible for a 3NM by 3NM area and varying types of vessels, including submarines, will transit the area at random intervals along the same axis (e.g. East/West).
- Scenario B: ASW in a Strategic Chokepoint. AUWS is tasked with detecting, classifying, and engaging any enemy submarines that attempt to navigate a strategic chokepoint. AUWS will be responsible for a 3NM by 3NM area and varying types of vessels will transit the area at random intervals along the same axis. At random, a submarine will transit the area and AUWS will be evaluated on its ability to detect, classify, identify, and decide to engage in a timely manner. All engagements will be simulated.
- Scenario C: Area Denial in a Strategic Chokepoint. AUWS is tasked with detecting, classifying, and engaging any enemy naval asset or any vessel known to be aiding the enemy in a strategic chokepoint. AUWS will be responsible for a 3NM by 3NM area and varying types of vessels, including submarines, will transit the area at random intervals along the same axis. AUWS will be evaluated on its simulated ability to engage targets designated hostile and its ability to allow non-hostile targets to pass through the area.

Instrumentation Requirements

Actual vessels – including naval, merchant, and submarine – will be needed for all test scenarios. Also, support vessels will be needed for deploying, monitoring, and recovering AUWS and associated test equipment. Telemetry equipment will need to be placed on sensor, communicator, and weapon nodes to determine if appropriate signals are detected, transmitted, and received. RF communications equipment, apart from the equipment organic to AUWS, may be necessary to transmit real-time telemetry data to a monitoring support vessel or shore station. A mockup of an AUWS operator console will be needed to determine if AUWS is displaying the correct information to the user.

Conduct of tests at the Atlantic Undersea Test and Evaluation Center (AUTEK) is recommended. AUTEK is an instrumented laboratory that performs integrated three-dimensional hydrospace/aerospace trajectory measurements covering the entire spectrum of undersea simulated warfare: calibration, classifications, detection, and destruction. Facilities for fixed and rotary wing aircraft support are available.

AUTEK utilizes the Tongue of the Ocean (TOTO), as shown in Figure J.1. TOTO is a unique deep-water basin approximately 110 nautical miles long by 20 nautical miles wide, varying in depth from 700 to 1100 fathoms. The basin floor is relatively smooth and soft, with very gradual depth changes. TOTO is bounded on the west by Andros Island (home of the testing facility), to the south and east by large areas of very shallow banks that are non-navigable, and to the north by the Northwest Providence Channel. This unique geography results in very low vessel traffic, minimal distant shipping noise, an absence of large ocean swells, and slight currents, while providing operational security and easy access to deep water. The test range sea surface covers

2,670 square nautical miles. North of the TOTO is a shallow-water plateau that varies in depth from 5-400 fathoms (9-731 meters). This convenient plateau is a prime choice for satisfying littoral warfare test requirements.

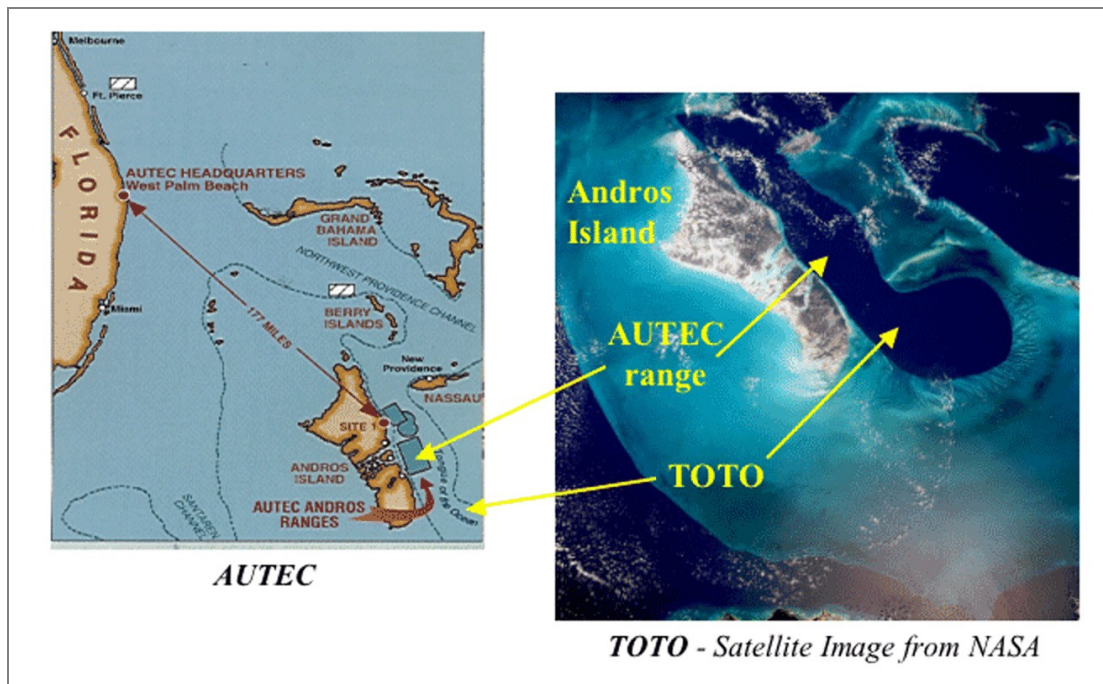

Figure J.3: Overview of AUTECH Geography¹⁸⁹

The AUTECH Range Support Facility houses a torpedo post-run workshop, test torpedo Intermediate Maintenance Activities (IMA) and extensive technical laboratory facilities. The complex also includes electrical and physical calibration labs, a complete electronics maintenance shop, a dive locker, a precision machine shop/office and logistic spaces.

The AUTECH Weapons Range is primarily used to gather highly accurate positional data required to analyze and assess the performance of undersea warfare weapons, weapons systems, and component subsystems. The range provides for 3-dimensional in-water and in-air tracking of multiple objects simultaneously and is over 9 nm wide and 35 nm long. Installed telemetry is capable of tracking nine objects simultaneously.

Limitations to Scope of Test

Primarily, the test will be limited in realism by the quantity, variability, and behavior of the test vessels simulating normal maritime traffic. It may not be feasible in a testing environment to apply the same number of large vessels that actually transit many strategic chokepoints, such as the Strait of Malacca, on a daily basis. The test may not determine the traffic density at which

189 Bahamas Marine Mammal Research Organization. "News - November 2006." November 2006. [BahamasWhales.org](http://www.bahamaswhales.org/images/autec.gif). 16 May 2011 <<http://www.bahamaswhales.org/images/autec.gif>>.

AUWS becomes overwhelmed. The sheer variability of vessel types that transit the world's waterway may also not be feasible to re-create in a testing environment. Therefore, the test may not determine the system's ability to classify rare vessel types or which types the system has trouble classifying. Last, the erratic behavior of vessels in real world situations is very difficult to simulate. Rather than trying to mimic random navigation routes and sporadic course and speed adjustments, the test will utilize simple traffic patterns to establish a baseline performance for AUWS. These limitations to scope may impact several COIs, including Target Detection (Is AUWS capable of detecting targets in a timely manner?), Classification (Is AUWS capable of accurately classifying targets in a timely manner?), and Employment (Are the tactics developed for AUWS for deter and engage targets scenarios effective?).

The test will also be limited by the test site since it will only represent one type of environment where AUWS may be tasked to operate. It is impossible to test AUWS in every conceivable operating environment, so the test site chosen should be a physically representative sample of the most likely operating environments. This limitation will impact COIs such as Survivability (Can AUWS satisfactorily survive in various operating environments?) and Mobility (Is the mobility of AUWS sufficient for accomplishment of its combat mission in varying terrain and environmental conditions?).

Section 4: Operational Effectiveness

Scenarios and Run Profiles

Example Scenario

General Mission: AUWS is tasked with establishing a maritime operational picture in a strategically important strait. AUWS will be responsible for a 3NM by 3NM area and varying types of merchant and naval vessels, including submarines, are expected to transit the strait. AUWS is tasked with detecting and classifying traffic to establish baseline patterns and identifying contacts of interest. AUWS must report contacts of interest and suspicious activity to a remote command center in a timely manner. AUWS must transit 100 NM to the operating area to maintain safe standoff range for manned deployment assets.

Background and Context: Over recent months, the strait and surrounding region have become increasingly unstable. The world economy is being disrupted by piracy and smuggling in the area. Local military and law enforcement efforts have proven ineffective. The lack of order increases the risk of maritime terrorism against US naval and merchant ships. One of the regional powers near the strait has been building up its navy for several years. Intelligence indicates that the nation intends to establish maritime superiority in the strait and surrounding waters. In addition, the nation is believed to possess autonomous vehicle capabilities. Several smaller powers in the region rely on small, fast craft and diesel submarines for coastal defense.

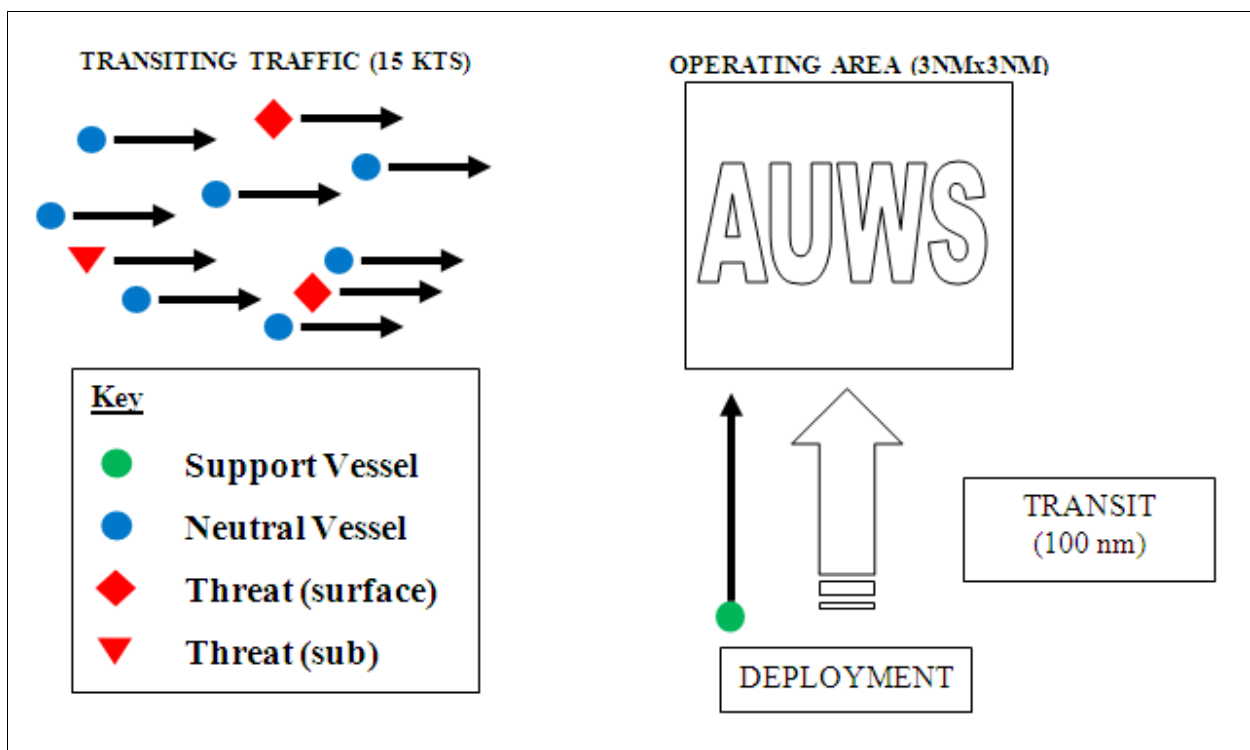

Figure J.4: Scenario Diagram

Test Environment: Operational testing will be conducted at the Atlantic Undersea Test and Evaluation Center (AUTEC) near Andros Island, Bahamas. Additional target vessels, or noise-generating devices, will need to be utilized to simulate realistic operating conditions.

Test Participants: The AUWS testing team, AUTEC range personnel, and personnel to man the target vessels will be participating in the testing.

Test Vessels: In order to simulate realistic traffic in the strait, a variety of merchant and naval vessels, including submarines, will be used. Specifically, the testing will utilize the following vessels:

- Neutral
 - 1 Tanker
 - 1 Container Ship
 - 1 High Speed Vessel (e.g., SEA SHADOW, SEA FIGHTER, or HSV)
 - 4 Small (e.g., fishing) Vessels
- Threat
 - 1 Patrol Craft (PC)
 - 1 Frigate (FFG)
 - 1 Diesel Submarine (SS must be borrowed from international military partner, last US diesel submarine, USS Dolphin, decommissioned in 2007)

A support vessel for testing team and AUTEC personnel will also be utilized. The support vessel will simulate a deploying asset and deploy AUWS over-the-side at the southern end of TOTO, transit to the operating area, and then monitor the test.

Threat Tactics: Diesel Submarine will transit the area running on battery in attempt to remain undetected. Threat surface combatants will attempt to flood the area with broadband noise to confuse AUWS and prevent the system from communicating critical information and completing an engagement.

Table J.4: COIs Addressed

COI #	Title	Question
2	Mobility	Is the mobility of AUWS sufficient for accomplishment of its combat mission in varying terrain and environmental conditions?
4	Target Detection	Is AUWS capable of detecting targets in a timely manner?
5	Classification	Is AUWS capable of accurately classifying targets in a timely manner?
10	Survivability	Can AUWS satisfactorily survive in various operating environments?
11	Human System Integration	Is AUWS user friendly and safe for human involvement?
12	Interoperability	Will AUWS be interoperable with existing platforms and systems currently employed?

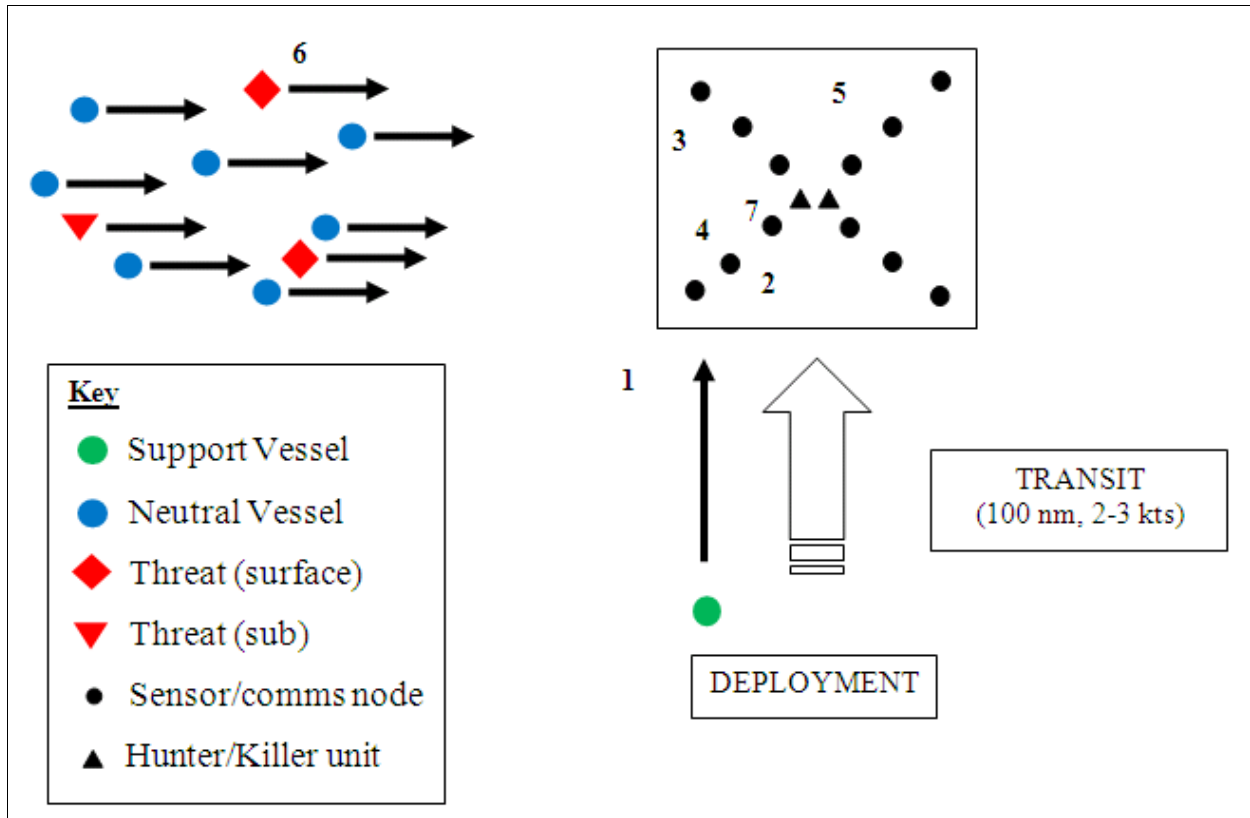

Figure J.5: Run Profile Diagram

Run Profile Timeline

1. Support vessel deploys AUWS at the southern end of TOTO, 100 NM from the operating area.
2. AUWS transits north to the operating area at 2-3 kts. Support vessel does not need to transit with AUWS since AUTEK installed equipment can monitor AUWS' transit. Although the long transit significantly increases the duration of the test, it is necessary to test the operational mobility of the system. When AUWS reaches the operating area, it deploys sensor/comms nodes and places the Hunter and Killer units in the center of the area. Test vessels begin transiting at 15 kts once AUWS is on station and operational.
3. AUWS will detect merchant traffic and collect ISR data. AUWS will prioritize which information must be transmitted based on mission and tactical situation. During the test, all information collected on merchant traffic should be stored and only information regarding threat contacts should be transmitted.
4. AUWS will detect and classify threat surface combatant. After the node(s) collects as much data as possible, and it is behind the threat sonar's field-of-view, it will communicate a processed message (not raw data) to the Hunter unit.
5. The Hunter will determine whether the information needs to be transmitted urgently or routinely to an external command center (e.g. test support vessel), and propose a recommended course of action. The Hunter will consider the current mission, tactical

situation, past experience, threat behavior, and many other factors in its decision making process. During the test, only the threat submarine should be reported urgently to the support vessel. The Killer unit will not be tested in this scenario.

6. The second threat surface combatant will utilize broadband noisemakers to confuse AUWS and prevent communication via the acoustic network. Upon detecting the broadband noise, the Hunter unit will deploy its retractable sensor buoy and attempt to identify the source vessel with an optical sensor. If required, the Hunter unit could cue the Killer unit with laser communications to prosecute the jamming vessel (will not be evaluated in this test). The Hunter unit will send a message to the support vessel that the system is being jammed and, if possible, provide a visual image of the jamming vessel. Broadband noise will stop before the submarine enters the operating area.
7. AUWS will detect and classify the threat submarine. After the node(s) collects as much data as possible, and it is behind the threat sonar's field-of-view, it will communicate a processed message (not raw data) to the Hunter unit. The Hunter unit will report detection of the submarine and associated information, including course, speed, confidence level, and recommended course of action.

Effectiveness Test 2b: Mobility (Navigational Accuracy)

Objective

To determine the undersea mobility of AUWS with regard to navigational accuracy.

Procedure

AUWS will be fit with precise GPS sensors external to AUWS' internal navigation sensors. During execution of all run profiles, data will be collected on AUWS' actual location at one second intervals. Data will simultaneously be collected from the AUWS' internal navigational sensors at one second intervals. Data collection will occur throughout operations encompassing various speeds, elevation, and terrain conditions. The data will then be transferred to the E-2 Data Sheet (Annex B) immediately following completion of the scenario run. This test addresses MOE 2.2, MOP 2.2.1, MOP 2.2.2, and MOP 2.2.3.

Data Analysis

Data analysis will be quantitative in nature. The data will be analyzed to determine the difference between the reported location and the actual location, both in terms of location and elevation. The data will be analyzed via t-tests to determine whether there is a statistical difference between the actual and reported locations (in terms of meters). A confidence level will be determined and a "Go" assessed if it is determined that there is no statistically significant difference between the sensors' readings.

Effectiveness Test 6a/b: Prosecution (Engagement Rate)

Objective

To determine the ability of AUWS to prosecute enemy threats in a timely manner.

Procedure

The engagement rate will assess the time required to positively identify and deploy a weapon. The tactical scenarios will include a single target as well as multiple threat targets in the operating area. The time from target presentation to weapon release will be recorded for each threat. Delays in the firing sequence will be noted and recorded. Data will be recorded to the E-6 Data Sheet following each scenario run. HSI data will be collected from the HSI survey conducted at the completion of all testing. This test addresses MOE 6.1, MOP 6.1.1, MOP 6.1.2 and MOP 6.1.3.

Data Analysis

AUWS engagement rate will be quantitative in nature. AUWS must be able to engage an identified threat target within 5 minutes or less. Data will be analyzed on AUWS' ability to satisfy single and multiple engagements. Mission aborts and delays will be collected and analyzed. Operator errors and mechanical failures will also be recorded and analyzed. A "Go" will be assessed if AUWS can meet the criterion outlined in the operational requirements. Confidence intervals will be calculated using the t-statistic.

Effectiveness Test 7b: Lethality (Accuracy)

Objective

To determine the accuracy of AUWS weapons system.

Procedure

The accuracy test will assess the reliability of AUWS weapons to fire and hit targets at prescribed ranges to satisfy operational requirements. AUWS will be placed in a weapons range and tasked to engage targets (singly) at various ranges. A trial will be conducted for 10 separate targets. The test will end upon completion of the 10 engagement trials. Data will be recorded for each engagement. This test will address MOE 7.2, MOP 7.2.1, and MOP 7.2.3.

Data Analysis

Accuracy will be quantitative in nature. Mission aborts and delays will be recorded and analyzed. Mechanical failures and crew errors will also be recorded and analyzed. A "Go" is achieved if the weapon intercept achieves criteria specified in operation requirements.

Confidence levels will be calculated using the t-statistic. The effectiveness data will be recorded on Data sheet E-7. HSI data will be recorded on Datasheet S-7.

Effectiveness Test 10a: Survivability (Detection Avoidance)

Objective

To determine AUWS' ability to avoid detection by enemy threats.

Procedure

The detection avoidance test will assess AUWS' ability to avoid detection in multiple operating environments. AUWS will then take measures to conduct operations against the contacting force while reducing its detection. Such actions will include incorporating stealth, running silent, and other masking procedures, as well as using terrain to minimize exposure. Data will be recorded via underwater range telemetry equipment. Time of enemy actions will be recorded. Data will be recorded on Data Sheet E-10 immediately following scenario conclusion. This test will address MOE 10.1, MOP 10.1.1 and MOP 10.1.2.

Data Analysis

Data analysis will be both qualitative and quantitative in nature. Qualitative assessments will be made of the environmental conditions at the locations of AUWS during detections to account terrain, current, ambient noise, scaled from zero to one. Quantitative assessments will determine the mean and standard deviations of the detection range. Additionally, sensor data will be evaluated to determine the percent of a particular AUWS component actually detected (communication vs. weapon unit). From this data, we will develop a confidence interval describing the ability of AUWS to avoid detection. Data errors will be recorded and analyzed. A "Go" will be assessed if AUWS can avoid detection at distances greater than 10 meters.

Section 5: Operational Suitability

Suitability Test 1a/b: Human Factors

Objective

To determine the user-friendly degree and safety of AUWS.

Procedure

In order to test Humans Factors Engineering all items requiring maintenance during operational tests will be logged by test technicians. Additionally, potential sources of frustration will be noted by technicians for further review at the conclusion of the test. Safety and Health Hazards

will also be identified in a running log by test technicians. This test addresses MOE 11.1, MOP 11.1.1, MOP 11.1.2, MOE 11.2 and MOP 11.2.1.

Data Analysis

The Humans Factors Engineering will be identified from the list of maintainability problems and assigning a impact rating based on a severity rating. Severity will be based on man-hours required for each maintenance requirement. The Safety and Health Hazards will be logged and rated by an associated Risk Assessment Code.

Suitability Test 2: Interoperability

Objective

Determine the interoperability of AUWS with existing platforms and systems.

Procedure

During operational testing AUWS will transfer data to airborne, surface, and sub-surface assets to determine interoperability of the system with systems on other platforms. The data transfer will occur at multiple ranges to determine maximum range at which sufficient data transfer occurs. This test addresses MOE 12.1, MOP 12.1.1, MOP 12.1.2, MOE 12.2, MOP 12.2.1, and MOP 12.2.2.

Data Analysis

The data that will be analyzed will the total number of data exchanges and total number of successful data exchanges. The MOE will be the proportion of successful data exchanges.

Annex A: Resource Requirements

Resource Type	Required
Test Articles	AUWS (qty 3)
Test Sites	Surface and Undersea Operating Areas (AUTECH) Undersea Weapons Range (AUTECH) Fleet Concentration Area
Instrumentation	Telemetry and Position Beacons as provided by AUTECH
Threat Systems/Simulators	MSC Cargo/Container Ship MSC Tanker/Oiler HSV Small Vessels (qty 4) PC (Patrol Craft) FFG/LCS SS (from international partner) EMATT (qty 12) REXTORP (qty 2) DDG/CG/LPD P-8 F/A-18 Vessels of Opportunity in FCA (launch/recover testing)
Simulations	Operator Teams (qty 2)
Manpower	Test Site Personnel
Training	Assigned Ship's Force
Special Requirements	Data Collection and Analysis at Test Site(s)
T&E Funding	\$19M

Annex B: Data Sheets and Questionnaires

E-2: Navigation Effectiveness Datasheet

Trial Number	Initial Reported Location	Initial Actual Location	Final Reported Location	Final Actual Location	Time Enroute	Deviations from Route	Corrections to Route	Error Range	Error Direction	Current	Successful Run? 1 = Yes, 0 = No
1											
2											
3											
4											
5											
6											
7											
8											
9											
10											
11											
12											
13											
14											
15											
16											
17											
18											
19											
20											
21											
22											
23											
24											
25											

S-1: Human Factors Questionnaire

AUWS Control Operator

NAME _____

RANK _____

MOS/NEC _____

YRS EXPERIENCE _____

INSTRUCTIONS: For each question, circle the response that best represents your degree of agreement with the statement. Comments are required for “Neutral,” “Disagree,” and “Strongly Disagree” responses, optional for “Strongly Agree” and “Agree.”

1. The AUWS Control is easy to power ON / OFF.

Strongly Agree Agree Neutral Disagree Strongly Disagree

Comments:

2. The AUWS Digital Control Displays are easy to read.

Strongly Agree Agree Neutral Disagree Strongly Disagree

Comments:

3. All labels and warning/caution placards were easy to read from a normal seated position.

Strongly Agree Agree Neutral Disagree Strongly Disagree

Comments:

4. Procedures for responding to system casualties were readily available.

Strongly Agree Agree Neutral Disagree Strongly Disagree

Comments:

5. The required information needed to initiate a launch is readily available from the console.

Strongly Agree Agree Neutral Disagree Strongly Disagree

Comments:

6. AUWS position and navigation appeared to update near-real time.

Strongly Agree Agree Neutral Disagree Strongly Disagree

Comments:

7. The AUWS navigation controls are easy to control/manipulate.

Strongly Agree Agree Neutral Disagree Strongly Disagree

Comments:

8. The reaction time from when a navigation command to when the system appears to respond is satisfactory.

Strongly Agree Agree Neutral Disagree Strongly Disagree

Comments:

9. All controls can be reasonably reached by the operator from a comfortable operating position.

Strongly Agree Agree Neutral Disagree Strongly Disagree

Comments:

10. The transitions between levels of autonomy appeared seamless.

Strongly Agree Agree Neutral Disagree Strongly Disagree

Comments:

11. You clearly understood the operational implications of each level of autonomy.

Strongly Agree Agree Neutral Disagree Strongly Disagree

Comments:

12. System operation was consistent with current Rules of Engagement (ROE).

Strongly Agree Agree Neutral Disagree Strongly Disagree

Comments:

13. Data link connectivity is easily monitored by the console operator.

Strongly Agree Agree Neutral Disagree Strongly Disagree

Comments:

14. All physical controls (buttons, switches, toggles, etc) appear durable and can withstand normal operational usage.

Strongly Agree Agree Neutral Disagree Strongly Disagree

Comments:

15. All alarm indications were easily audible or visible.

Strongly Agree Agree Neutral Disagree Strongly Disagree

Comments:

16. All alarm conditions were easily identified once the operator is alerted.

Strongly Agree Agree Neutral Disagree Strongly Disagree

Comments:

17. Targeting function satisfactorily responds and readies the user and system for firing sequence.

Strongly Agree Agree Neutral Disagree Strongly Disagree

Comments:

18. Weapon selection and employment was easily completed.

Strongly Agree Agree Neutral Disagree Strongly Disagree

Comments:

19. The number of false contacts was minimal (did not distract operator from valid contacts).

Strongly Agree Agree Neutral Disagree Strongly Disagree

Comments:

20. The system satisfactorily completed all tasking in the operational testing scenario.

Strongly Agree Agree Neutral Disagree Strongly Disagree

Comments:

21. The console did not cause physical discomfort when the operator was in normal seated position.

Strongly Agree Agree Neutral Disagree Strongly Disagree

Comments:

22. You felt safe the entire you were operating AUWS.

Strongly Agree Agree Neutral Disagree Strongly Disagree

Comments:

23. Training was adequate (operator felt prepared to execute tasking at completion of training).

Strongly Agree Agree Neutral Disagree Strongly Disagree

Comments:

24. Actual console operation was consistent with training received.

Strongly Agree Agree Neutral Disagree Strongly Disagree

Comments:

25. I am confident that this system can satisfactorily complete mission assignments.

Strongly Agree Agree Neutral Disagree Strongly Disagree

Comments:

Annex C: OMITTED

Annex D: Data Analysis Plan

Variable	Control	Factor Level/Treatment
Neutral Vessel Movement	Systematically Varied	Transit, Loiter
Threat Surface Vessel Movement	Systematically Varied	Transit, Loiter
Threat Submarine Movement	Systematically Varied	Transit, Loiter
Sound Velocity Profile	Uncontrollable	As occurs
Atmospheric Transmission	Uncontrollable	As occurs
Undersea Currents	Uncontrollable	As occurs
System/Equipment Failures	Uncontrollable	As occurs
Weather	Uncontrollable	As occurs
Deployment Method	Constant	Single Hunter/Killer Pair
Communications	Constant	Undersea and UHF
Software	Constant	Version X.X
Position Accuracy	Measured	Meters
Number of Detections	Measured	Instances
Weapon Accuracy	Measured	Meters
Engagement Time	Measured	Minutes

Works Cited

- Alibaba.com. Magnesium air fuel cell. 2011. 13 May 2011 <http://www.alibaba.com/product-free/101662196/Magnesium_air_fuel_cell.html>.
- AllAboutBatteries.com. "Battery energy storage in various battery types." 12 January 2011. *AllAboutBatteries.com*. 5 May 2011 <http://www.allaboutbatteries.com/contact_us.html>.
- Avago Technologies. "Reliability Data Sheet, AFCT-57J5APZ, AFCT-57J5APZ-XXX." *Avago Technologies* 7 Jun. 2008. 23 Apr. 2011.
- Bacon, Lance. "The Scoop Deck - Advanced Gun System hits milestone." 28 May 2010. *MilitaryTimes.com*. 2 May 2011. <<http://militarytimes.com/blogs/scoopdeck/2010/05/28/advanced-gun-system-hits-milestone/>>.
- Bahamas Marine Mammal Research Organization. "News - November 2006." November 2006. *BahamasWhales.org*. 16 May 2011 <<http://www.bahamaswhales.org/images/autec.gif>>.
- Blanchard, Benjamin S., Systems Engineering Management, 3rd ed. Hoboken: John Wiley & Sons, Inc, 2004. 328.
- Blanchard, Benjamin S. and Wolter J. Fabrycky, Systems Engineering and Analysis, 4th ed. Upper Saddle River, 2006. 77.
- Bluefin Robotics. RoboClam Anchoring Technology. Boston: Bluefin Robotics, 2011.
- Booz Allen Hamilton. "Navy Virginia Class Cost Reduction Approach." 19 Apr. 2008. *Boozallen.com*. 25 Apr. 2011 <<http://www.boozallen.com/media/file/navy-virginia-class-cost-reduction-approach.pdf>>.
- Brunelle, Elaine. Personal interview. Oct. 2010.
- Buss, Arnold. "Simkit Home Page." 24 Mar. 2010. *Diana.nps.edu*. 12 May 2011 <<http://diana.nps.edu/Simkit/>>.
- Button, Robert W, et al. A Survey of Missions for Unmanned Undersea Vehicles. Santa Monica: RAND Corporation, 2009.
- Calvano, Charles. "SEA-17 Project Tasker." Monterey: Naval Postgraduate School, 2010.

Copperhead Chemical Company. "OTTO Fuel II." January 2006. *CopperheadChemical.com*. 3 May 2011. <http://www.copperheadchemical.com/Defense/OTTOFuelII_0106.pdf>.

Coyle, Geoff. The Analytic Hierarchy Process (AHP). Harlow, 2004. 2.

DARPA. "Renewable at-sea power."
<http://www.darpa.mil/Our_Work/STO/Programs/Renewable_At-Sea_Power.aspx>.

Digital Energy Journal. "Ocean bottom seismic – improving cost and reliability." Digital Energy Journal 19 Jul. 2010. 23 Apr. 2011.
<http://www.findingpetroleum.com/n/Ocean_bottom_seismic_improving_cost_and_reliability/58f46b59.aspx>.

Drennan, Frank. Personal interview. 10 Oct. 2010.

DSPComm "AquaComm: Underwater Wireless Modem." 2009. *DSPComm.com*. 2 May 2011.
<http://www.dspcomm.com/products_aquacomm.html>.

Dudinsky, John. L2D2: Large Diameter Long Duration UUV. Panama City: 2011.

Eagle, James. Naval Tactical Analysis Lecture Notes. Monterey: Naval Postgraduate School, 2009. 9.

Electric Vehicle News. "Nissan say Leaf EV Battery Pack Cost Only \$375 per kWh." 6 May 2010. *electric-vehicles-cars-bikes.blogspot.com*. 13 May 2011 <<http://electric-vehicles-cars-bikes.blogspot.com/2010/05/nissan-say-leaf-ev-battery-pack-cost.html>>.

Ellis, W.G. Personal interview. Oct. 2010.

Everhart, Dave. Personal interview. Oct. 2010.

Federation of American Scientists. "MK-48 Torpedo." 12 December 1998. *FAS.org*. 25 Apr. 2011
<<http://www.fas.org/man/dod-101/sys/ship/weaps/mk-48.htm>>.

Federation of American Scientists. "Submarine-Launched Mobile Mine (SLMM)." 12 Dec. 1998. *fas.org*. 19 May 2011. <<http://www.fas.org/man/dod-101/sys/ship/weaps/slmm.htm>>.

Fischhoff, B., et al., Approaches to Acceptable Risk: A Critical Guide. Eugene: Oak Ridge National Laboratory Sub-7656, 1980. 98.

- 2010 Fuel Cell Seminar & Exposition, October 18-21, Richard Carlin 23 Apr. 2011
<http://www.fuelcellseminar.com/media/5502/carlin_10_19_2010.pdf>.
- Galambos, James. P. Advanced Technology, Applied Research Lab, Pennsylvania State University. 2009. <<http://www.arl.psu.edu/capabilities/at.html>>.
- Gates, Robert M. "The National Defense Strategy: Striking the Right Balance." *Joint Forces Quarterly* Jan. 2009. 5-6.
- Government Accounting Office. "Defense Acquisitions: Assessment of Selected Major Weapon Programs." Washington: GPO, 2005. 27.
- Government Accounting Office. Defense Acquisitions: Challenges Remain in Developing Capabilities for Naval Surface Fire Support. Washington: GPO, 2006. 11.
- Hague Conference of 1907. "Avalon Project - The Laws of War." 18 Oct. 1907. *Yale.edu*. 22 Apr. 2011. <http://avalon.law.yale.edu/subject_menus/lawwar.asp>.
- Hahn, Danny. "The Analytic Hierarchy Process." 2007. *INCOSE.org*. 11 May 2011
<<http://www.incose.org/sfbac/2007events/071113ahp.pdf>>. 1-35.
- Harney, Robert C. "Sensor Functional Characteristics. Vol. 1." Harney, Robert C. Combat Systems. Monterey: Naval Postgraduate School, 2004. 335-340.
- Hebert, David. Personal interview. Oct. 2010.
- Hill, Randy. Personal interview. 16 Sept. 2010.
- Hiznay, Mark, Operational and technical aspects of cluster munitions. Washington: Arms Division of Human Rights Watch, 2006. 20.
- Hogg, James R. "The Unmanned Imperative." 2009.
- Hoerner, Sighard. Fluid Dynamic Drag. Brick Town: Hoerner Fluid Dynamics, 1965.
- Honegger, Barbara. NPS Pioneers "Seaweb" Underwater Sensor Networks. 2010.
<<http://www.nps.edu/About/News/NPS-Pioneers-Seaweb-Underwater-Sensor-Networks.html>>.
- Hunt, Richard. Personal interview. Dec. 2010.

- IEEE, "Lithium-Ion Batteries for Telecom Application", 2007 IEEE 23 Apr. 2011
<<http://ieeexplore.ieee.org/stamp/stamp.jsp?arnumber=04448872>>.
- IHS Global Limited. "Jane's Underwater Warfare Systems: AN/BQQ-10." 23 Jul. 2010.
Janes.com. 21 Apr. 2011
<http://search.janes.com.libproxy.nps.edu/Search/documentView.do?docId=/content1/janesdata/yb/juws/juws2014.htm@current&pageSelected=allJanes&keyword=BQQ-10&backPath=http://search.janes.com/Search&Prod_Name=JUWS&>.
- IHS Global Limited. "Mk 46 Torpedo." 6 December 2010. *Janes.com*. 3 May 2011
<http://search.janes.com.libproxy.nps.edu/Search/documentView.do?docId=/content1/janesdata/yb/juws/juws0493.htm@current&pageSelected=allJanes&keyword=Mk 46 Torpedo&backPath=http://search.janes.com/Search&Prod_Name=JUWS&>.
- IHS Global Limited. "Mk 48 ADCAP." 27 July 2010. *Janes.com*. 3 May 2011.
<http://search.janes.com.libproxy.nps.edu/Search/documentView.do?docId=/content1/janesdata/yb/juws/juws0501.htm@current&pageSelected=allJanes&keyword=Mk 48 torpedo&backPath=http://search.janes.com/Search&Prod_Name=JUWS&>.
- IHS Global Limited. "Mk 50 (Barracuda) Lightweight Torpedo." 6 May 2010. *Janes.com*. 1 May 2011
<http://search.janes.com.libproxy.nps.edu/Search/documentView.do?docId=/content1/janesdata/binder/jalw/jalw3119.htm@current&pageSelected=allJanes&keyword=Mk 50 torpedo&backPath=http://search.janes.com/Search&Prod_Name=JALW&>.
- Intel Corporation. "A Conversation with Gordon Moore: Moore's Law." 2005. *intel.com*. 13 May 2011
<ftp://download.intel.com/museum/Moores_Law/Video-Transcripts/Excepts_A_Conversation_with_Gordon_Moore.pdf>.
- Jeopardy! Dir. Kevin McCarthy. Sony Pictures Television. 2011.
- Joint Chiefs of Staff. JP 3-15: Joint Doctrine for Barriers, Obstacles, and Mine Warfare. Washington, D.C.: Joint Chiefs of Staff, 1999. I-V.
- Langford, Gary. Systems Engineering Integration Handbook for SE4151. Monterey: Naval Postgraduate School, 2009.
- Lockheed Martin Corporation. "Long Range Land Attack Projectile (LRLAP)." 2009.
LockheedMartin.com. 4 May 2011.
- 155-mm M109 SP Howitzer, Military Periscope, 1 Jun. 2009. 23 Apr. 2011.
<<http://www.periscope.ucg.com/mdb-smpl/weapons/artguns/selfprop/w0003617.shtml>>.

Martin, Gifford. Personal interview. Oct. 2010.

Martin, Gifford. Quickstrike (QS) Mod 3 Program Overview. Nov. 2009

Matthews, Tony. Personal interview. Oct. 2010.

McMullen, Teresa. Compact Rapid Attack Weapon (CRAW). Arlington: 2009.

Medrano, Antonio. "IBM Watson." 2011. *enr.ucsb.edu*. 13 May 2011
<http://www.engr.ucsb.edu/~medrano/CS240A/HW1/CS240A_Homework_1/CS240A_Homework_1_-_F._Antonio_Medrano.html>.

Messina, John. "Magnesium: Alternative Power Source." 23 Apr. 2010. *Physorg.com*. 3 May 2011 <<http://www.physorg.com/news191259549.html>>.

"Mk-48 CBASS." *Deagle.com*. 25 Mar. 2011. <http://www.deagel.com/Torpedoes/Mark-48-CBASS_a001143002.aspx>.

National Aeronautics and Space Administration. "NASA TRL Meter." Washington: NASA, 2004.

Naval Center for Cost Analysis. "JIC_Inflation_Calc_FY11_Ver1a.xls." 2011. *ncca.navy.mil*. 13 May 2011 <www.ncca.navy.mil/tools/JIC_Inflation_Calc_FY11_Ver1a.xls>.

Naval Center for Cost Analysis. Naval VAMOSC. 1996. 13 May 2011
<<https://www.vamosc.navy.mil/>>.

Naval Mine and Anti-submarine Warfare Command. Mine Warfare Update. San Diego: Department of the Navy, 2009.

Naval Surface Warfare Center, Panama City. Advanced Undersea Weapon System. Panama City, 2010.

Naval Surface Warfare Center, Panama City, "Large Diameter, Large Duration Unmanned Undersea Vehicle (L2D2-UUV) Initiative." Panama City: Department of the Navy, 2010.

Nicholas, Ted and Rossi, Rita. "SONAR/Sonobuoy Costs." Military Cost Handbook. 13th ed. Fountain Valley: Data Search Associates. 2009. 3-4.

Nicholas, Ted and Rossi, Rita. "Torpedo/Mine Costs." Military Cost Handbook. 12th ed. Fountain Valley: Data Search Associates. 1991. 9-4, 9-5.

Obama, Barack. National Security Strategy. Washington, D.C.: Office of the President of the United States, 2010. 5, 34, 50.

Ocean Power Technologies. (n.d.). "PB150 PowerBuoy." *OceanPowerTechnologies.com*. 20 May 2011. <<http://www.oceanpowertechnologies.com/pb150.htm>>

O'Donnell, Jerry. Personal interview. Oct. 2010.

Office of the Secretary of Defense. Unmanned Systems Roadmap (2009-2034). Washington D.C.: Department of Defense, 2009.

The Ordnance Shop. "MK 46 TORPEDO." *ordnance.org*. 3 May 2011 <http://www.ordnance.org/mk_46_torpedo.htm>.

O'Rourke, Ronald. Navy Force Structure and Shipbuilding Plans: Background and Issues for Congress. Washington, D.C.: Congressional Research Service, 2010.

Osmundson, John. Combination Diagrams. Monterey: Naval Postgraduate School.

Pike, John. "Long Range Land Attack Projectile." 30 May 2007. *GlobalSecurity.org*. 4 May 2011. <<http://www.globalsecurity.org/military/systems/munitions/lrlap.htm>>.

Pike, John. "SSN-774 Virginia-class NSSN New Attack Submarine." 5 Sept. 2008. *GlobalSecurity.org*. 1 May 2011. <<http://www.globalsecurity.org/military/systems/ship/ssn-774-spiral-2.htm>>.

Polmar, Norman. "The Ships and Aircraft of the U.S. Fleet: Torpedoes." United States Naval Institute Proceedings, Nov.1978. 159.

Raymond A. Serway, Robert J. Beichner and John W. Jewett. Physics for Scientists and Engineers. New York City: Saunders College Publishing, 2000.

RESON Inc. "Hydrophone TC4032." 2005. *RESON.com*. 5 May 2011 <<http://www.reson.com/wp-content/uploads/2010/12/TC4032.pdf>>.

Rice, Joseph. Seaweb. Monterey: Naval Postgraduate School, 2010.

Roughead, Gary. CNO Guidance for 2011. Washington, D.C.: Office of the Chief of Naval Operations, 2011. 1, 5-7.

- Rowinski, Lech. "Submersible propulsion and energy." 18 Mar. 2002. *underwater.pg.gda.pl*. 23 Apr. 2011.
<http://www.underwater.pg.gda.pl/publikacje/submersible_conceptual_design_using_computer_aids.pdf>.
- Russian Federation, United Kingdom of Great Britain and Northern Ireland and United States of America. "Treaty on the Prohibition of the Emplacement of Nuclear Weapons and Other Weapons of Mass Destruction on the Sea-bed and the Ocean Floor and in Subsoil Thereof (Seabed Treaty)." 11 Feb. 1971. *NTI.org*. 22 Apr. 2011.
- Shin, Young S. Ship shock modeling and simulation for far-field underwater explosion. Monterey: Elsevier Ltd., 2002.
- Sibley, Christy. CJTF Sea Tiger, Anti-Submarine Warfare: Impact of the Advanced Undersea Warfare System (AUWS) on the Submarine Battle. Monterey: Naval Postgraduate School, 2011.
- Singer, P.W. Personal interview. 15 Mar. 2011.
- Smith, David. CJTF Sea Tiger Maritime Component: Added use of VCAP Component. Monterey: Naval Postgraduate School, 2011.
- Smith, Preston G and Guy M. Merritt, Proactive Risk Management. New York: Productivity Press, 2002. 72.
- Smith, Roger M. and Joseph A. Walsh. "The Navy Unmanned Undersea Vehicle Master Plan." 2004.
- Standifer, Cid. "CNO Wants 30-Day Mission in Seven Years." *Inside the Navy* 22 Oct. 2010.
- Systems Engineering Department. Systems Assessment Lecture Notes. Monterey: Naval Postgraduate School, 2010.
- Tan, Geoffrey. Warheads. Singapore: DSO National Laboratories, 2010. 4.
- Teledyne Webb Research. "Thermal Glider." 2010. *WebbResearch.com*. 5 May 2011
<<http://www.webbresearch.com/thermal.aspx>>.
- Thomsen, James E., Victor G. Guillory and Thomas A. Benes. The Navy Unmanned Surface Vehicle (USV) Master Plan. Washington D.C.: Department of the Navy, 2007.

Truver, Scott C. "What 'Weapons That Wait?'" *Seapower*. Jun. 2011. 6

United States Cong. Bob Stump National Defense Authorization Act for Fiscal Year 2003.
Washington: GPO, 2003. 243.

United States Department of Energy. World Oil Transit Chokepoints: Malacca. Feb. 2011. 12
May 2011 <http://ei-01.eia.doe.gov/emeu/cabs/World_Oil_Transit_Chokepoints/Malacca.html>.

United States Naval Academy. "Ambient Noise: The background noise of the sea." *USNA.edu*.
13 May 2011 <<http://usna.edu/Users/physics/ejtuchol/Chapter11.pdf>>.

United States Navy Fact File. "U.S. Navy Mines" 15 Jan. 2009.
<http://www.navy.mil/navydata/fact_display.asp?cid=2100&tid=700&ct=2>.

University of Rhode Island. "DOSITS: What are common underwater sounds?" 2009.
DOSITS.org. 2 May 2011 <<http://www.dosits.org/science/soundsinthesea/commonsounds/>>.

Wander, Andrew. "Middle East in huge naval expansion." 31 March 2010. *aljazeera.net*. 16 Oct.
2010 <<http://english.aljazeera.net/news/2010/03/201033014527639619.html>>.

Warren A. Rosen, and Alan D. George. "Fault Tolerance Considerations in Autonomous Acoustic
Arrays." Office of Naval Research.

Whiteneck, Daniel, et al. The Navy at a Tipping Point: Maritime Dominance at Stake?.
Alexandria: Center for Naval Analysis, 2010.

Woodbank Communications Ltd. "Battery Performance Characteristics - How to specify and test
a battery." 2005. *mpoweruk.com*. 3 May 2011.
<<http://www.mpoweruk.com/performance.htm>>.

Initial Distribution List

1. Defense Technical Information Center
Ft. Belvoir, Virginia
2. Dudley Knox Library
Naval Postgraduate School
Monterey, California