



Calhoun: The NPS Institutional Archive

Theses and Dissertations

Thesis Collection

2010-06

Vulnerability analysis of an all-electric warship

Hanthorn, David Gordon

Massachusetts Institute of Technology

<http://hdl.handle.net/10945/4942>



Calhoun is a project of the Dudley Knox Library at NPS, furthering the precepts and goals of open government and government transparency. All information contained herein has been approved for release by the NPS Public Affairs Officer.

**Dudley Knox Library / Naval Postgraduate School
411 Dyer Road / 1 University Circle
Monterey, California USA 93943**

<http://www.nps.edu/library>

Vulnerability Analysis of an All-Electric Warship

by

David Gordon Hanthorn

B.S., Computer Engineering, Syracuse University 2001

Submitted to the Department of Mechanical Engineering and Engineering
Systems Division in partial fulfillment of the requirements for the degrees of

Naval Engineer
and
Master of Science in Engineering and Management
at the
Massachusetts Institute of Technology

June 2010

© 2010 David G. Hanthorn. All rights reserved.

The author hereby grants to MIT permission to reproduce and to distribute
publicly paper and electronic copies of this thesis document in whole or in part in
any medium known hereafter created.

Signature of Author

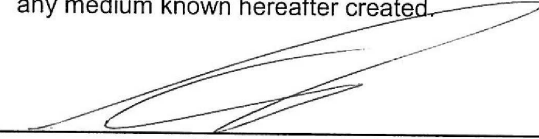

Department of Mechanical Engineering and
System Design and Management Program

07 May, 2010

Certified by



Chryssostomos Chryssostomidis

Doherty Professor of Ocean Science and Engineering
Director, MIT Sea Grant College Program

Thesis Supervisor

Accepted by

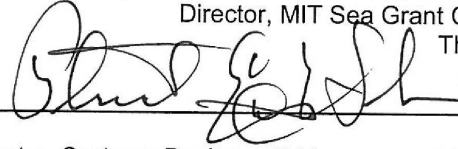

Pat Hale

Director, Systems Design and Management Fellows Program
Engineering Systems Division

Accepted by



David Hardt

Chairman, Committee for Graduate Students
Department of Mechanical Engineering

Page Intentionally Left Blank

Vulnerability Analysis of an All-Electric Warship

by

David Gordon Hanthorn

Submitted to the Department of Mechanical Engineering on May 7, 2010 in
Partial

Fulfillment of the Requirements for the Degrees of

Naval Engineer

and

Master of Science in Engineering and Management

Abstract

Traditional design processes usually rely on cost as the metric the designer uses to select among different alternatives. Sometimes when costs cannot be calculated we use weight, volume and efficiency as surrogates for cost. However minimizing costs does not necessarily give us the best design for a particular mission; this is particularly true for military ships. Proposals to include such considerations as quality of service and survivability as metrics to be used in a multi objective design process or as constraints have appeared in the literature. A tool that analyzes survivability of distributed systems at early stage design does not exist. In this thesis we develop a metric for survivability suitable for early stage design of destroyers.

Thesis Supervisor: Chryssostomos Chryssostomidis

Title: Director, Sea Grant College Program, Doherty Professor of Ocean Science and Engineering, Professor of Mechanical and Ocean Engineering

Thesis Supervisor: Pat Hale

Title: Director, Systems Design and Management Fellows Program

Acknowledgements

The author would like to thank the following organizations and individuals for their assistance. This thesis would not have been possible without them.

- This work is supported in part by the Office of Naval Research N000014-08-1-0080, ESRDC Consortium, N00014-09-1-0160, Sea Basing: T-Craft Dynamic Analysis, and MIT Sea Grant College Program, NA06OAR4170019.
- Professor Chryssostomos Chryssostomidis for his continued patience and constant guidance, steering me down the right path.
- Dr. Julie Chalfant for her invaluable insights, elegant writing ability and MATLAB coding abilities that brought this to a close.
- Pat Hale for bringing the 2N students into the SDM program.
- Zachary and Andrew who were “Good for Daddy” during the countless hours at the computer.
- Finally, my wife Jess who is ever supportive and loving and who found a way to manage life and the kids without me while I finished this up.

- Table of Contents

1	Introduction	8
2	Vulnerability Metric	9
2.1	Why is Ship Survivability a Concern?	9
2.2	What is Survivability and Why Focus on Vulnerability?	9
2.3	Current Survivability Analysis Method	9
2.4	Proposed Early-Stage Vulnerability Metric	10
2.4.1	Prioritized Load List	10
2.4.2	Metric 1 - Ship Operational Capability	13
2.4.3	Metric 2 - Vulnerability Resistance	14
2.5	Metric Calculation	14
2.6	Examples	16
3	Architectural Model	18
3.1	Current Ship Design Methodology	18
3.2	New Early-Stage Design Tool	20
3.2.1	Analysis Tools	21
3.2.2	Variable Component Selection (Inputs)	22
3.2.3	Metrics (Output)	23
4	Setup Paramarine	24
4.1	Paramarine Iterations	26
5	Trade-Off Study	28
5.1	Variant Selection	28
5.2	Comparison	28
5.2.1	Weight	29
5.2.2	Volume	29
5.2.3	Efficiency	30
5.2.4	Vulnerability	31
6	Conclusions	32
6.1	Summary	32
6.2	Areas of Future Study	32
Appendix A. Hull and Superstructure Import		34
Appendix B. Weight Parametric Analysis		36
Appendix C. Variable Component Positioning		38

Appendix D. Combat Systems Positioning.....	40
Appendix E. Paramarine Iterations.....	42
Appendix F. Damage Scenario.....	44

Table of Figures

Figure 1 Task List with Relative Weighting	11
Figure 2 Vulnerability Tiers	14
Figure 3 Visual Representation of Damage	15
Figure 4 Sample Ring Bus Electric Plant Layout	16
Figure 5 Ship Operational Capability Scores	17
Figure 6 Combined Tier Results	17
Figure 7 Functional Representation	21
Figure 8 Required ASSET Inputs.....	22
Figure 9 Components of Interest to Evaluate the Electrical Systems of a Ship ..	23
Figure 10 SWBS Weight Groups	24
Figure 11 Electric and Propulsion Plant Arrangement in Paramarine	25
Figure 12 Weapons System Layout	25
Figure 13 Complete Paramarine Model	26
Figure 14 Early stage Design Iterations	27
Figure 15 Variant PGMs	28
Figure 16 Weight Comparison	29
Figure 17 Volume Comparison	30
Figure 18 Electric Loading Conditions	30
Figure 19 Required Propulsion Power	31
Figure 20 Efficiency Comparison	31
Figure 21 Vulnerability Comparison	31

1 Introduction

This thesis begins by discussing the importance of survivability and its application in today's Navy. Current methods of survivability analysis are discussed and light shed on the fact that no tool currently exists to analyze survivability of distributed systems at the early stages of design. The effect early stage design has on survivability is presented setting the stage for a proposed solution.

The proposed solution will come in the form of a metric and a computer based tool to apply it in design. An architectural model is developed allowing the designer to perform trade-off studies in the early stages of design. Exploration of the current design methodology will follow, leading to a new proposed methodology. The discussion of this new methodology will include variable inputs to the model, quantitative outputs and a description of the model's arrival at them.

A process which the designer can follow to use this tool in the early stages of design to affect desired results is laid out. In conclusion this process is followed and applied to a trade-off study comparing two variants, one with four power generation modules (PGM) and one with six.

2 Vulnerability Metric

2.1 Why is Ship Survivability a Concern?

Commercial shipping, pleasure craft and warships are all exposed to many hazards of navigation. Ship's damage may come from collisions, groundings or weapons effects. In most cases commercial shipping and pleasure craft designers are not concerned with weapons effects. This is a point that makes the warship unique. These ships must be designed to navigate hostile waters where the threat of encountering damage from a weapon is a real concern. By designing a ship that is survivable there may be less personnel casualties onboard the vessel. Additionally there is a desire for the ship to continue to perform its primary missions. By doing this the ship may be able to prevent a subsequent attack that may cause further casualties and possibly the loss of the ship. These consequences result in loss of life, loss of military assets, ability to accomplish missions and increased costs as a result of these.

2.2 What is Survivability and Why Focus on Vulnerability?

Survivability of a ship is comprised of three facets. The different aspects of survivability can be divided into susceptibility, vulnerability, and recoverability [Yarbrough and Kupferer 2002]. Susceptibility measures the ability of the ship to respond to threats, including evasion and defeat before impact. Vulnerability is the ability to withstand the impact and continue to carry out the mission. Recoverability, which occurs after initial damage, focuses on the ability of the ship and crew to restore functionality.

Vulnerability is influenced by structural integrity and water tight integrity of the ship. Components within the ship affect vulnerability and can be controlled by redundancy, separation and zonal distribution. These items can be controlled by the designer and to have maximum effect, they should be implemented in the early stages of design.

The focus here is on vulnerability with a primary concern being the effect of initial damage on the ship's mission. Operational procedures, damage control efforts and recoverability are not accounted for in this thesis.

2.3 Current Survivability Analysis Method

The current method for analyzing survivability of a ship is accomplished using a mission set of the ship and a series of potential threats. The ship's ability to respond to those threats, including the ability to defeat or evade the threats before impact, the ability to withstand the impact, and the ability to recover from the impact using both onboard and in-theatre resources, are combined into a measure of survivability involving Design Threat Outcomes that range from completely unaffected to total loss of the ship and personnel. See, for example,

[Doerry 2007a] and [Yarbrough and Kupferer 2002]. This extensive survivability analysis can take weeks to properly calculate; in the early stages of design, the ship may have gone through several iterations in that amount of time, rendering the survivability analysis obsolete before its completion. In addition, the analysis measures the survivability of the ship as a whole including the effectiveness of a multitude of factors such as weapons systems, personnel performance, operational profile and ship design, many of which are beyond the scope of a specific trade-off study.

2.4 Proposed Early-Stage Vulnerability Metric

There currently exists no method to analyze the effects of distributed systems design on the overall vulnerability of a ship; development of such a method would be valuable in early-stage ship design. The metric must be computed rapidly to enable decision-making during early-stage ship design, yet must accurately represent the survivability aspects of the design. Since distributed system design has little impact on susceptibility and recoverability when compared to other factors, we concentrate on the vulnerability portion of the survivability equation.

We developed a twofold vulnerability metric to measure two distinct issues: the first measure indicates the impact of unfulfilled loads by delineating the highest priority capability that ship is unable to perform, and the second measure indicates the overall percentage of loads that cannot be fulfilled. These two measures are discussed in detail in sections 2.4.2 and 2.4.3.

The metrics presented here are a framework to analyze the ship's vulnerability. It is up to the designer to interpret both the customer requirements and governing instructions and tailor this metric to meet their intent.

2.4.1 Prioritized Load List

In order to develop the vulnerability index (metric) we start by enumerating a list of tasks that any military ship (destroyer) has to perform. To construct the list, we assumed the ship is in a damaged state, then prioritized the loads so that the ship can survive the damage, continue to operate, and meet its missions, in that order. A sample list is shown in Figure 1 together with a relative weighting for the different tasks. The granularity of this listing was driven by the desire to achieve a manageable number of items while still providing sufficient breakdown to thoroughly assess vulnerability. This listing may be modified by the customer to achieve the desired level of granularity for the specific application, and task weighting may be adjusted as well.

Priority	Task List	Weight
1	Power Generation	16
2	Damage Control	15
3	Basic Mobility	14
4	Self Defense	13
5	Exterior Communications	12

6	Helicopter and Boat Recovery	11
7	Increase Speed to 10 knots	10
8	Basic Offense	9
9	Full Flight Operations	8
10	Increased Offense	7
11	Increase Speed to 20 knots	6
12	Miscellaneous Supporting Mechanical Services	5
13	Full Offense	4
14	Increase Speed to 25 knots	3
15	Non-vital Loads	2
16	Increase speed to Maximum Possible	1

Figure 1 Task List with Relative Weighting

A brief explanation of each task is given below.

Power generation: For each generator that is operational there must be power supplied to the associated auxiliaries such as lube oil, vent fans, fuel, starter, control panel, alarms, etc. The engineering control system must also be active.

Damage Control: Fire fighting, dewatering, lighting, electrical receptacles (for powering damage control equipment such as submersible pumps, blowers), basic ventilation, interior communications, countermeasure washdown are all required. Additionally emergency medical support and potable water distribution are needed for the crew.

Basic Mobility: Enough propulsion is required to achieve 4 knots which is bare steerageway. To accomplish this one motor and drive, associated propulsion sensors, control system and one steering system (hydraulics, controls) must all be functioning.

Self Defense: A point defense system is required such as SeaRAM/CIWS or equivalent (self-contained system that requires only electrical power and chill water to operate). Other items important for this task include electronic warfare sensor (such as SLQ-32 or basic InTop) and missile decoy such as NULKA or chaff.

Exterior Communications: To support this task a full external communications suite including IFF and TACAN are required. Navigation systems required online are basic close-in radar and gyro.

Helicopter and Boat Recovery: Basic helicopter systems required for recovery of helicopters only and not full flight operations; e.g., landing lights, RAST, winches, control station. For boat recovery there must be power to the davit.

Increase speed to 10 knots: Since this speed is attainable on one shaft only more electrical power is required.

Basic Offense: To achieve this certain sensors, weapons and ship control systems must be online. The assumption is made that a low-power level of radar is available with degraded performance either reducing range, resolution, or both. The ship must have the ability to bring hull-mounted sonar capability online. Ship control system must be energized including weapons control and sensor integration in all intact zones. For weapons, one of any redundant systems such as gun, torpedo, VLS must be energized. Only energize a weapon if supporting sensors are available; e.g., do not energize torpedoes if sonar not available, do not energize VLS if sufficient radar not available. This also requires an increase in chill water capacity by adding pump, compressor, and ASW pump. Remaining ventilation systems should also be brought online.

Full Flight Operations: All flight equipment not already energized, including refueling capability and fuel transfer must be brought online.

Increase Offense: Increase radar to a medium power level. Increase cooling capacity to support the systems. Activate the remaining weapons systems, excluding high-energy weapons.

Increase speed to 20 knots.

Miscellaneous supporting mechanical services: Fan cooling units for all spaces, air compressors, battery chargers for small boats, helo, gyro, potable water equipment including distillers, reverse osmosis units, brominator, etc. must be online.

Full Offense: Increase radar to full power level. Provide sufficient cooling. Energize high-energy weapons (rail gun, laser). Activate towed-array sonar, if applicable.

Increase speed to 25 knots.

Non-Vital Loads: All non-vital loads. Examples include galley equipment, heat, water heaters, laundry, stores handling, and miscellaneous machinery systems such as fuel transfer, air compressors, anti-icing, lube oil heating, sewage treatment.

Increase speed to maximum possible: This would require full power generation and both propulsors online.

2.4.2 Metric 1 - Ship Operational Capability

The first metric determines the highest priority operation that cannot be achieved, thus indicating whether the system is unable to serve a critical load in mission performance.

A tiered vulnerability system was constructed by grouping the categories from the electrical load priority list as described above into tiers that establish expected capability of the ship following damage. The vulnerability tiers developed for the notional ship are shown in Figure 2. For the ship to meet any vulnerability tier, it must meet the minimum requirements of that tier and all lower tiers. For example, a ship that meets tier three must achieve 4 knots (basic mobility) with steering capability and have one operational self-defense system as described in tier three, but must also have two operational firepumps (damage control) and one generator with associated auxiliaries as described in tier two, and must have sufficient power to service all of those loads simultaneously.

Tier	Description	Minimum Requirements
1	Does not meet Power Generation and Damage Control - Ship's status is likely to continue to degrade	
2	Meets Power Generation and Damage Control- Ship is able to combat existing damage but is vulnerable to further threats.	One operational generator with associated auxiliaries, two firepumps.
3	Meets Basic Mobility and Self Defense - Is able to sustain itself against the enemy.	Achieve 4 knots with steering, one self-defense system (either a CIWS/SeaRAM or a sensor and associated missile decoy system).
4	Meets Exterior Communications and Helicopter and Boat Recovery - Basic functionality without offense.	One operational mode of exterior communications, close-in radar, able to recover helicopter and boat.
5	Meets Increased Speed and Basic Offense - Can perform at least one primary mission	Operate at 10 knots, perform one primary mission.
6	Meets Full Flight Operations and Increased Offense - Can perform most or all primary missions	Flight operations, two primary missions
7	Meets Increased Speed, Mechanical Services and Full Offense - As far as a military asset, unaffected	Power to all loads at this level and below

8	Complete functionality - all loads are fulfilled	Fulfill all loads, including non-vital loads
---	--	--

Figure 2 Vulnerability Tiers

The tiers do not include the loss of ship due to adjacent compartment flooding. This decision was made because it is not directly affected by distributed system arrangements and criteria are clearly specified in various reference documents [Lewis 1989].

Tier one states that the ship's condition will likely continue to deteriorate following an attack. This decision was based on the premise that the inflicted damage would cause fire or flooding in the ship and a lack of damage control capability or power would allow these casualties to spread until the ship was lost.

The second tier is based on the same thought process except the existing casualty can be combated; however, further threats are likely and there is no self-defense system (CWIS) available to combat them.

Once tier three is obtained, the ship has reached minimal self sufficiency, bare steerageway is available and the ship can defend against further attacks. The subsequent tiers represent increases in ship's speed and military capability.

This portion of the metric provides a functional snapshot of the ship's capability following damage. Its usefulness stems from the breakdown of equipment into functional performance groups. This metric still lacks the ability to fully measure the system's ability to deliver power to the remaining loads on the ship, which drove the development of a second metric.

2.4.3 Metric 2 - Vulnerability Resistance

The second metric is a total load value that calculates the maximum value of all loads that can be serviced, proceeding in priority order, thus indicating a weighted total of all loads that can be serviced by the damaged system. The same prioritized list of electrical loads as shown in Figure 1 was used for this metric. The weighting scheme is decided by the user based on the relative importance of electrical loads. In this case the weighting was done as shown in Figure 1. A ratio of the damaged weighted total to the undamaged weighted total provides a weighted total percent availability or Vulnerability Resistance Percentage.

2.5 Metric Calculation

The vulnerability metric is constructed as follows. First, given a set of loads, establish a weighted, prioritized list for servicing the loads, as shown in section 2.4.1. The list of loads is automatically adjusted such that a load that has been destroyed by the imposed damage is removed from the list, as there is no reason at that point to allocate resources to it.

Second, group the weighted prioritized loads into tiers indicating levels of operation that establish expected capability of the ship following an attack, as

shown in section 2.4.2. Define the minimum operational capability threshold required to consider a tier to be met.

When selecting locations on the ship to apply damage, a random pattern of points on the hull and superstructure was first considered. This process was of interest because in reality damage locations cannot be fully predicted. However, for consistency of results across design iterations and modifications, reproducible results were desired. To accomplish this, reasonable locations were chosen that represent possible scenarios. The number of damage points is high enough that it is unlikely that the ship would be designed to score notably higher in this scenario than other possible scenarios.

Blast centers were located along the skin of the ship along three horizontal planes. The design waterline and deck edge were selected for the first two planes of damage. The third height for the superstructure was obtained by taking the difference of the first two planes and adding it to the deck edge yielding heights of 6.6m, 12.6m and 18.6m from baseline. The longitudinal positions were chosen to be at each of the transverse bulkheads. This would show a worst case scenario affecting the greatest number of compartments when subjected to different blast radii. The blasts were centered on the skin of the ship. The interpolation process for determining transverse location is described in Appendix F.

The blast diameters selected were .5, 1.0 and 2.0 times average transverse bulkhead spacing, yielding 5.2m, 10.4m and 20.8m. These would need to be modified if additional bulkheads were added to the design since average spacing would change.

Finally, calculate the vulnerability scores for each blast location as follows:

For each blast location and diameter, equipment is considered destroyed if the blast sphere intersects the bounding box of the equipment as shown in Figure 3; all bounding boxes are axially aligned. In addition, equipment is considered destroyed if any one component of a system is destroyed. For example, if a shaft is lost, the associated propeller, motor and motor drive are removed from the list of available equipment [Chalfant 2010].

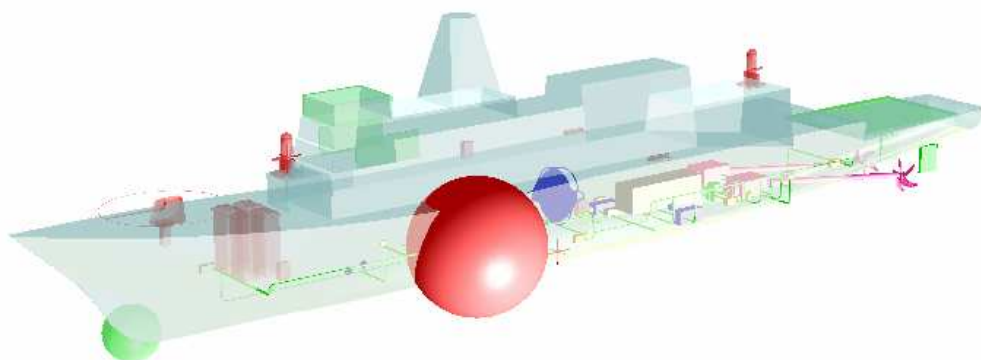

Figure 3 Visual Representation of Damage

Connectivity between all remaining equipment is determined using Dijkstra’s algorithm. Power is then allocated to the remaining equipment based on connectivity in a manner that maximizes the function $f*x$, in which f is the weighting value from Figure 1 and x is the amount of power provided to the load. For details, see [Chalfant 2010].

The logic tree provided by the tier system of Figure 2 is followed to determine the highest tier for which the minimum requirements are met and for which all lower tiers are met. In order for equipment to satisfy this requirement, it must both be undamaged and have sufficient power.

This algorithm is run initially with no damage to determine the maximum possible vulnerability resistance score, which is equal to $f*x$ as described above. The vulnerability resistance percent is then the vulnerability resistance score divided by the maximum possible.

This process is repeated for each of the imposed damage locations and radii. These results are compiled and summarized for the final result.

2.6 Examples

Figure 4 shows a sample ring-bus electrical plant layout for a ship with four generators (grey), four major loads (yellow) fed directly from the bus, and four zonal loads (orange) fed from the bus via appropriate converters (green). The vessel is divided into four zones; disconnect switches (red) are located between each zone and forward and aft to allow for split plant operations. We ran a test of the vulnerability metric for three plant configurations: first, all switches are closed for full connectivity; second, the bow and stern disconnect switches are open for split plant operations, and third, the port bus is completely disabled.

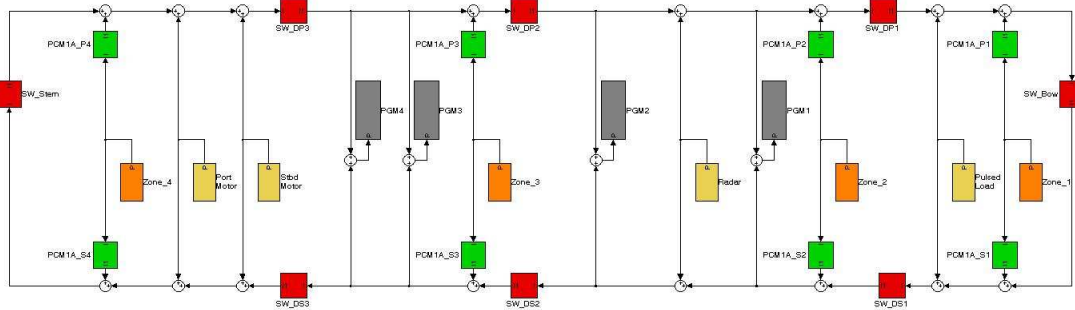

Figure 4 Sample Ring Bus Electric Plant Layout

A total of 198 damage locations were imposed on the ship. Each hit location has two corresponding vulnerability metric values that are calculated. Figure 5 is a breakdown by tier of the Ship Operational Capability scores as described in section 2.4.2. This breakdown can be useful when attempting to determine locations in the ship that are particularly sensitive to damage.

Tier	Full Connectivity	Split Plant	Single Bus
------	-------------------	-------------	------------

1	0	0	0
2	13	13	26
3	20	20	22
4	24	24	20
5	30	30	30
6	7	7	6
7	34	34	94
8	70	70	0

Figure 5 Ship Operational Capability Scores

For most cases and design iterations a combined result is more beneficial than examination of each individual score. Figure 6 is the combined result of all 198 hit locations. For example, in full connectivity 165 hits out of 198 allowed operation in tier four or higher (24+30+7+34+70). The average vulnerability is representative of the ship's vulnerability resistance. This is achieved by the calculation of the second metric described in section 2.4.3. The number of hits less than 100% represents the total number of locations that sustained damage resulting in less than 100% functionality. The final result is the average tier the ship design received out of the maximum score of eight.

The vulnerability metric does point out more vulnerable designs, as we expected. Note that the initial design of these plants is very redundant; major loads and converters for each zone are powered from both buses. Thus, operating with both full connectivity and split plant show very high vulnerability resistance and there is little difference between the vulnerability scores, but the split plant case is shown to be slightly more vulnerable. The single bus case has noticeably lower scores, which we would expect as the configuration is much more vulnerable.

	Full Connectivity	Split Plant	Single Bus
Average Vulnerability Resistance	89.20%	89.17%	84.98%
# Hits < 100%	128	128	198
Average Tier	5.92	5.92	5.26
Standard Deviation	2.05	2.05	1.90

Figure 6 Combined Tier Results

3 Architectural Model

The vulnerability metric developed above is now placed within the context of an early-stage design tool. The MIT Sea Grant Design Laboratory is involved in a body of work to develop an overall architectural model of an all-electric ship using a physics-based simulation environment to perform fully-integrated simulation of electrical, hydrodynamic, thermal, and structural components of the ship operating in a seaway. The goal of this architectural model is to develop an early-stage design tool capable of performing tradeoff studies on concepts such as AC vs. DC distribution, frequency and voltage level, energy and power management options, and effect of arrangements and topology. We will initially address the hull, mechanical and electrical (HM&E) systems that support the ship and its missions; this thesis specifically addresses the electrical generation and distribution system. The metrics that have been chosen for evaluation of options are cost, weight, volume, efficiency/fuel consumption, reliability and vulnerability.

Throughout the design process the level of design detail increases from concept/feasibility, preliminary, contract and detailed. Within each step of the process the concept is refined and changes to previously made decisions become more difficult and costly. It is for this reason that all final outcome metrics should be sufficiently explored early in the stages of design to minimize the final design cost while still reaching a desired solution. Thus, it is important that decisions of this magnitude be made in the concept and feasibility design iterations [NAVSEA 2005].

3.1 Current Ship Design Methodology

The process of ship design usually starts by determining a set of owner's requirements. These expectations are the cornerstone of the design process and the driver behind the design. The requirements generally begin as a set of desired mission capabilities and are used to derive performance parameters and design features that allow the design to meet the mission. The designer must guide the design using prioritized attributes based on the customer's desires.

It is imperative that the ship's design features are clearly linked to the stated requirements. In highly complex systems the design process is not rapid and customer requirements will likely change during the course of the design. Design standards such as vessel rules, military specifications and national and international rules further constrain the design. It is to note that these documents aid in focusing the design to a feasible solution based on historical data and experience.

Today, a computer model is normally used to determine key characteristics (independent variables) that fulfill the owner's requirements and satisfy operational constraints such as safety. This ensures a feasible and effective design. It is an inherently iterative process that continues until an

acceptable balance is reached; this process is referred to as the ship design spiral.

Ideally, an objective function is calculated from this computer model and the design space is searched for the optimum ship that best satisfies the function. A typical objective function minimizes cost. However, cost is notoriously difficult to properly calculate. In the absence of good cost data, other measures that give an indication of cost are used, such as weight, volume and efficiency. In warship design, measures such as survivability and lethality are used as well.

In U. S. Navy ship design, an early-stage design tool called Advanced Surface Ship Evaluation Tool (ASSET) is used [NSWCCD]. ASSET constructs a mathematical model that represents the ship based on parametric relationships that represent the state of the art and common practice used in ship design.

Given some initial information input by the designer, ASSET performs a design spiral process by iteratively sequencing through a series of modules that assess different naval architectural aspects of a vessel, including propulsor, machinery, auxiliary systems and hull characteristics such as structure, subdivision, geometry and resistance, plus hydrostatics and seakeeping. As the program iterates through the modules, it changes design parameter values until 'synthesis' is achieved, in which the underlying requirements are met.

ASSET requires that the designer have a basic understanding of the ship to be designed along with some principal design characteristics, beginning with length between perpendiculars (LBP). An inboard profile including general location and spacing of machinery rooms and deckhouse location and size is required, along with a fairly detailed list of mission-specific payload data including weight, space and electric load for items such as armament, sensors, command and control, and expendable loads. Manning must be delineated as well.

Beyond these basic inputs, there are a multitude of additional items that may either be supplied by the designer, selected from equipment libraries included with ASSET, or estimated by ASSET from parametric data. This flexibility allows the use of ASSET at varying stages of early ship design with varying detail input to the program.

This has been an effective process used by designers for rapid, accurate changes to the many design variables that have complex dependencies on other ship parameters. This methodology produces good initial results with minimal cost and risk allowing the designer to explore many trade-offs in the early stages of design.

The inherent success of ASSET can also be a drawback in some select situations. Because ASSET performs a design spiral analysis each time parameters are modified, a single change can have effects throughout the vessel. For example, changing the prime mover to a larger engine could cause transverse bulkheads to be moved to accommodate the length of the new turbine; this change could ripple through the vessel, in some instances even changing such basic parameters as length, beam and draft. If it is desired to conduct a trade-off study in which all parameters are held constant except for the specific change being studied, ASSET may not be the best tool. Although ASSET is a powerful ship design tool applying naval architecture principles, there

are some aspects of ship design that are not addressed. For example, it does not perform a vulnerability assessment.

3.2 New Early-Stage Design Tool

Because of the success of the current design methodology and the ease of use of ASSET, we approach the design problem in a similar manner. However, instead of automatically changing parameters to meet naval architecture requirements, we begin with a balanced ship, make changes, and check the naval architecture requirements. If they are not met, changes must be manually made by the designer. Thus, all the changes are completely controlled by the designer.

Previous versions of the architectural model used a balanced ship designed in ASSET, then performed analysis on the resulting information in overlay programs written in MATLAB; however, it was desired to improve the modeling of individual systems and the visualization portions of the design tool while retaining the naval architectural analysis and gaining control of all variables. Therefore additional tools were researched.

Unknown future needs drove the requirement the tool be flexible. To meet this requirement, the tool must have the ability to import data from other ship design programs (ASSET or others). Naval architectural analysis is another key component the tool must have, allowing the designer to ensure a feasible product. Finally the tool must have the capacity to include new algorithms or export data for calculation of such algorithms in another program.

When using a tool such as ASSET the design must meet certain predefined parametrics within a certain tolerance [NSWCCD]. To achieve this, ASSET automatically iterates the design changing parameters without the designer's direct control. This causes unwanted changes to the final design and irreproducible results. The designer must have complete control to perform accurate meaningful trade-off studies.

Paramarine [QinetiQ] is a piece of naval architectural software capable of performing many required ship analysis tasks. It was chosen for use in this application because of the inherent flexibility of the program and its ability to easily input and output data, along with specific control of all variables. This was required so that the designer could see the impact of changes in the ship's layout on naval architecture characteristics. Paramarine also has the ability to design a ship with a significant level of detail. This allows detailed description and placement of distributed systems in the ship.

A functional representation of the tool is displayed in Figure 7. This shows the interrelation of the programs, inputs and outputs.

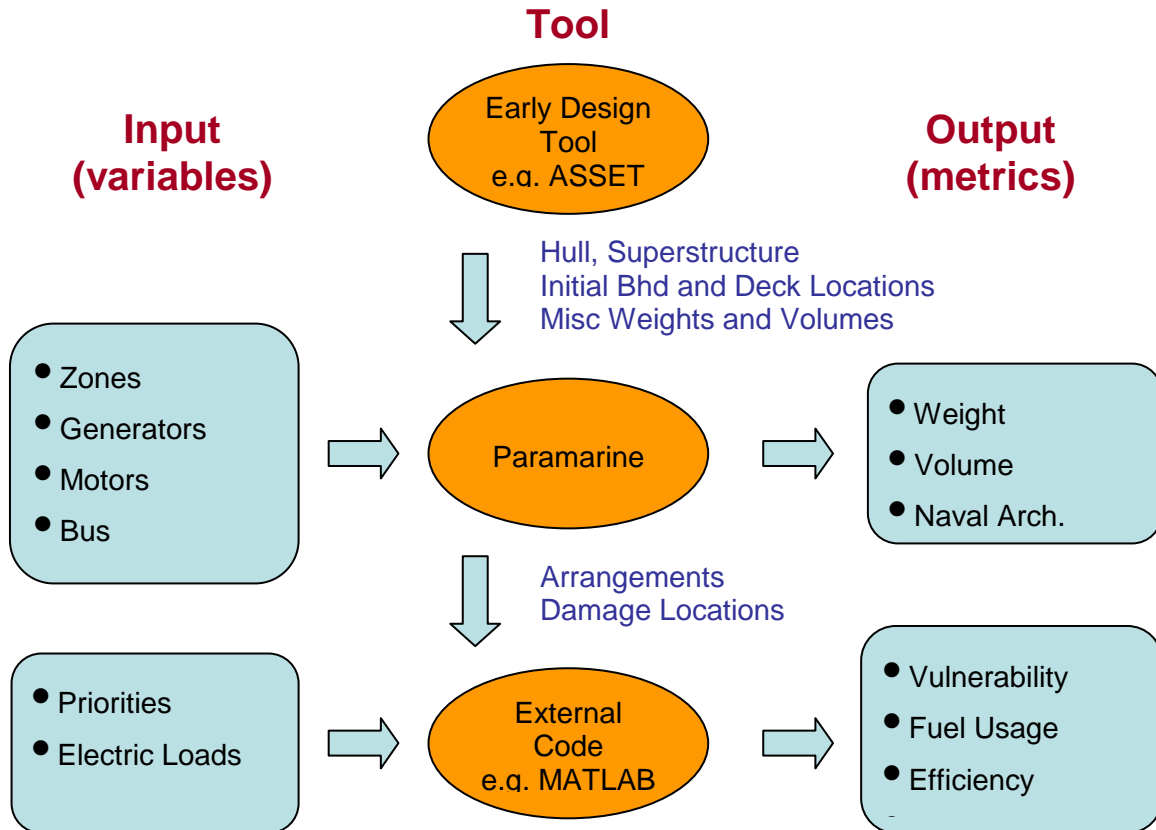

Figure 7 Functional Representation

3.2.1 Analysis Tools

ASSET was used as a starting point to efficiently generate a balanced feasible ship. The ship characteristics that do not affect vulnerability must be locked in place the same way the combat systems remain constant in the ASSET design. The key variables of interest must be freely controlled by the designer to create different variants with unique vulnerability characteristics. To accomplish this, a computer based tool must be selected allowing the flexibility to make specific changes. This new tool can be used to accomplish trade-off studies in which specific parameters are changed while holding all other values constant.

Once the design is in Paramarine, the variable components are selected from a user defined equipment library and arranged at the discretion of the designer. This is the stage where the designer can explore different zonal and bus architectures. Before proceeding the designer must ensure a feasible design by checking floodable length and hydrostatics. If required, deck, bulkhead and equipment locations may be manipulated to manually create a feasible design.

Matlab [MathWorks] was used to add capabilities beyond those of Paramarine. It was used for the calculation of the vulnerability metric and fuel consumption. Matlab gave the flexibility to import data and run any desired calculations or algorithms and export the results in any desired format.

3.2.2 Variable Component Selection (Inputs)

To perform the vulnerability analysis the user must provide two sets of inputs. The first set is required to create a balanced ship in ASSET. To create a ship in ASSET the designer must input performance requirements, combat systems and desired payload. An inboard profile of the vessel is required to determine other inputs listed in Figure 8. [NSWCCD]

ASSET Inputs
Length Between Perpendiculars
Number of Machinery Rooms
Type of Machinery Rooms
Location of Aft Machinery Room
Required Machinery Room Separation
Number of Levels in the Deckhouse
Longitudinal Location of the Deckhouse
Manning
Payload Data

Figure 8 Required ASSET Inputs

To apply the metrics to trade-off studies the balanced ASSET model must be imported into Paramarine. This is where the user selects the second set of inputs and decides which components are of interest and will be varied. The variables of interest may include weapons, sensors, propulsion or electrical equipment. For any ship the electric bus and propulsion plant are of great importance. To study electric power generation the power generation modules (PGM) and required conversion equipment including cabling and between them and routing paths must all be variable. These components are used to define zones and bus architectures. For propulsion the propulsion motor modules (PMM), shafting and propulsor are important.

To fully compute the metric as described here, weapons systems, sensors damage control equipment, communications and flight equipment must be modeled. This equipment causes changes in the metric due to changes in their location. As the metric is adapted, describing systems in greater detail the components selected for variable modeling must also be altered accordingly.

A few key variables were selected that are influential in the outcome vulnerability of an all-electric ship; these variables are listed in Figure 9.

Components of Interest
• Propulsion Motor Modules (PMM)
• Power Generation Modules (PGM)
• Transformers
• Rectifiers
• Cabling

- Shafting
- Gas turbine inlet/exhaust ducting

Figure 9 Components of Interest to Evaluate the Electrical Systems of a Ship

3.2.3 Metrics (Output)

The metrics we have chosen for evaluation of options are weight, volume, efficiency/fuel consumption, vulnerability, reliability and cost. The weight and volume metrics are defined simply as the change in weight and volume occupied by the equipment in each tradeoff as compared to the baseline. The metric for efficiency is annual fuel consumption, calculated using individual equipment efficiency values combined with a speed condition profile that delineates the percent of time spent at various speeds and battle conditions, the engines' specific fuel consumption (SFC) at each loading, and an engine usage profile. The efficiency metric is described more fully in Chalfant and Chrysostomidis [2009]. The vulnerability metric has been described above in Section 2. Cost and reliability metrics are yet to be included.

4 Setup Paramarine

This process begins with an initial ship balanced design in ASSET. Next, the hull and superstructure along with bulkhead locations are imported into Paramarine. The details of this process are contained in Appendix A.

To categorize weights the Ship's Work Breakdown Structure (SWBS) was used, Figure 10 [NSWCCD].

SWBS Weight Groups	
	Group
100	Hull Structure
200	Propulsion Plant
300	Electric Plant
400	Command and Surveillance
500	Auxiliary Systems
600	Outfit and Furnishings
700	Armament

Figure 10 SWBS Weight Groups

This is standard procedure in the Navy, and ASSET organizes components using this structure. Because only static characteristics of the ship are being imported into Paramarine, all weights of variable components (Shown in Figure 9) need to be removed from the totals. The weight and centers of gravity of each component were removed from each grouping. The remaining weights were adjusted using ratiocination based on changes to the ship's shaft horse power (SHP) and installed power generating capacity [Cimino 2006]. The details of this weight removal process are described in Appendix B. The remaining static weights and centers of gravity are entered into Paramarine as point loads.

With the static components positioned the variable components must be created in the Paramarine equipment library. Before the location of a component is specified it must be first created in the equipment library. This is accomplished by defining a geometry and assigning a weight. Next these components are selected and located in the ship. The electric system and propulsion systems are significant components to both ship design and the metric, they will be discussed first. The PMMs and PGMs were also positioned in the machinery spaces and shafting run to the propulsors. With power generators and motors installed the necessary power conversion equipment and distribution system arranged to supply the ship's loads. User defined cable ways are created and Paramarine routes the system cables through them. This process is described further in Appendix C and results shown in Figure 11.

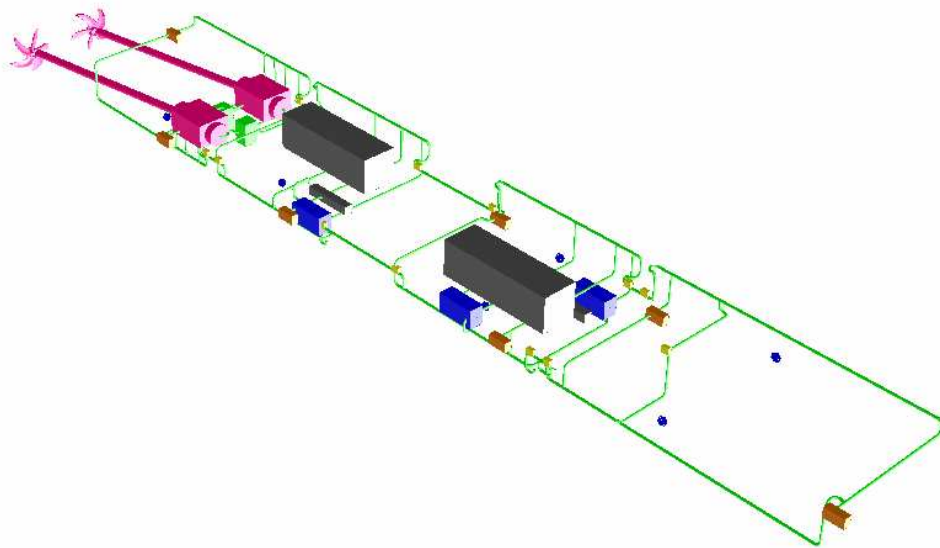

Figure 11 Electric and Propulsion Plant Arrangement in Paramarine

The other key element to the metric is the positioning and interrelating of the combat systems. Simple basic weapons system and sensor components were positioned at reasonable locations in and on the ship to simulate a possible destroyer. Control equipment supporting these objects was placed internal to the ship's hull. Details on this process are contained in Appendix D and results shown in Figure 12. The completed model in Paramarine is shown in Figure 13.

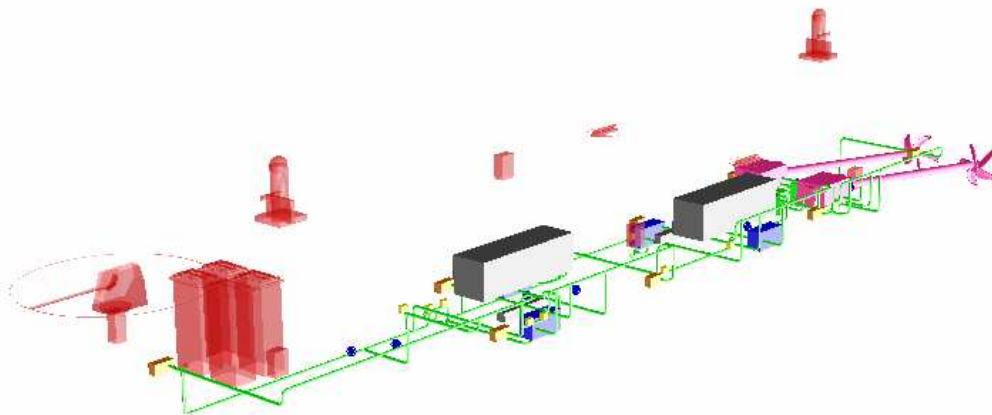

Figure 12 Weapons System Layout

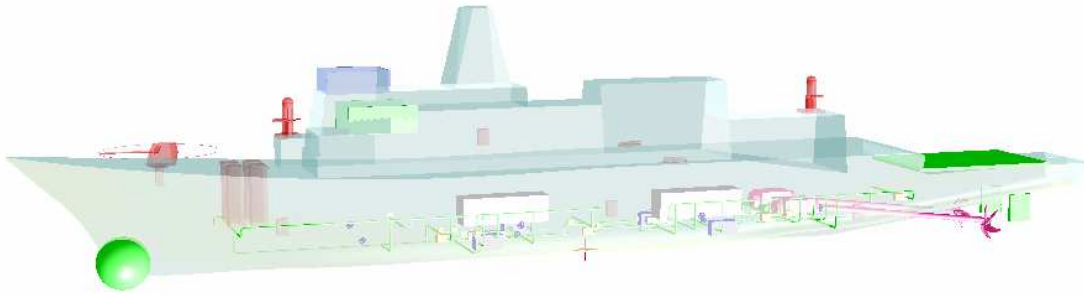

Figure 13 Complete Paramarine Model

4.1 Paramarine Iterations

At this stage in the process the designer is free to experiment with different architectural layouts of the variable components in Paramarine. Once component locations are determined decks and bulkheads may need to be added or repositioned to give required clearance to the installed machinery. These changes may invalidate the previous balanced ship, requiring a new feasibility analysis. If the ship does not meet the feasibility criteria then it is up to the designer to manually adjustment equipment, decks and bulkhead to meet them. If feasibility is obtained then the component location data will be exported to Matlab for metric computation. The designer can then make variant decisions based on vulnerability results, weight, volume and efficiency. Based on the outcomes the designer may iterate as necessary within the different tools to create an optimal solution as shown in Figure 14. A more detailed description of this iterative process is contained in Appendix E.

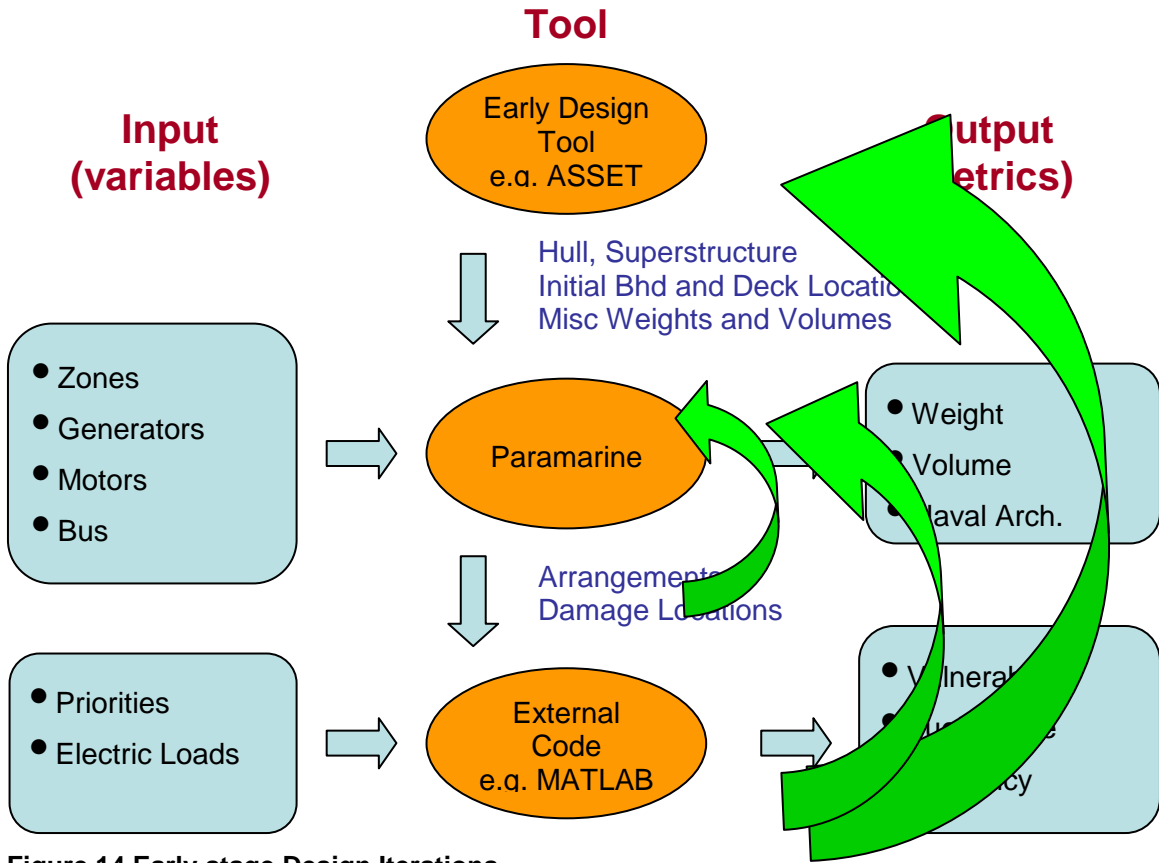

Figure 14 Early stage Design Iterations

5 Trade-Off Study

In this section, the architectural model and vulnerability metric are applied to a case study of a small surface combatant in which the number of generators is changed from four to six; total power generation capacity is essentially unchanged. The two variants were modeled nearly identically changing only the number of generators and required components to support this change.

5.1 Variant Selection

For comparison purposes the only components altered were the number of PGMs, raising it from four to six. PGMs were selected to have nearly equivalent total generating capacity. The remaining components of the propulsion system and weapons systems remained constant. Significant attempts were not made to optimize various parameters in the design; the focus was placed on creating a comparable design with additional PGMs.

No attempts were made to minimize ducting lengths for gas turbines when selecting PGM locations. This was to attempt consistency between the two design iterations and obtain comparable results. In both cases the generators were placed with same mean distance from centerline for consistency.

A few considerations arose when investigating possible PGMs for the six generator case. In an effort to avoid changes to the transverse bulkhead positions generators of similar size must be selected which limited the possibilities. First six generators of equal power were considered. It was found that generators in this capacity range are marginally smaller than the largest, highest output ones such as the LM2500+ and MT30. This would have required shifting bulkheads to accommodate the larger size. Given this data, the decision was made to move to a slightly smaller LM2500+ and use two additional LM500s to reach our goal of six generators. This provides similar installed capacity and uses commercially available generators. Summary information on the selected generators is presented in Figure 15.

Variant	Primary PGMs	Secondary PGMs	Total Capacity
4 PGMs	2 x MT30	2 x LM500	81 MW
6 PGMs	2 x LM2500+	4 x LM500	78 MW

Figure 15 Variant PGMs

5.2 Comparison

To compare two variants at this stage of design a comparison of weight, volume, efficiency and vulnerability was preferred.

5.2.1 Weight

The weight of components added to the design from the equipment library is automatically accounted for in Paramarine. Paramarine also includes the weight of the cabling required to connect the installed components. The weight of the inlet and exhaust ducting for the generators was done manually for simplicity in the design. To determine a weight-to-length ratio for the inlet and exhaust ducting for the gas turbines, the original data from ASSET was used. The length of the required ducting was manually calculated. The intake ducting on the generators is on forward portion of engine and exhaust on the aft portion. The intake was assumed to be one deck below the top deck of the superstructure above the generator. Likewise for the exhaust the associated duct is assumed to reach the top deck of the superstructure above it.

These lengths were multiplied by the weight to length ratio for each generator to reach a total duct weight. Weights of the stack, spray ring, silencer and eductor were all left constant and not affected by changes in the design. These items would be required even if the length of ducting changed due to generator location changes. These items are accounted for when additional generators are added to the design. For the two additional LM500s in the six generator case, 8.2 tonnes was added for both generator's stacks and is included in the weight for ducting. The final comparison of weight is shown in Figure 16.

	Weight (te)		Difference
	4 PGMs	6 PGMs	
Eng	160.00	197.60	23.50%
Elec	107.37	124.59	16.04%
Cable	96.98	108.24	11.60%
Ducting	40.14	64.60	60.93%
Total	404.49	495.02	22.38%

Figure 16 Weight Comparison

5.2.2 Volume

As with the weights, volume of components used in Paramarine's equipment library are automatically totaled in the design. Although the weight of the cabling was automatically calculated, the volume was not and needed to be manually accounted for. Cabling volume information was taken from ASSET using diameters and lengths. In Paramarine the total switchgear to switchgear cabling was totaled because this includes the bus work in the cableways. The individual length of cables to each PCM was summed and subtracted from the total. This was done because the way Paramarine tabulates cable length. To determine the volume required the diameter of the cable was multiplied by the length and used for the total cable volume demanded.

The trunk volumes for the generator ducting also needed to be manually totaled. The same assumptions for duct length were used as for weight. The cross sectional areas of the trunks were obtained from ASSET in both cases to

ensure consistency. The lengths and cross sectional areas were used to determine the volume required for all generator ducting. Although the ducting lengths of the primary PGMs are comparable in both cases, the six generator case requires less cross sectional area actually lowering the required ducting volume.

	Vol m ³		Difference
	4 PGMs	6 PGMs	
Eng	372.748	376.021	0.88%
Elec	79.796	105.396	32.08%
Cable	15.975	19.246	20.48%
Ducting	1397.652	1392.81	-0.35%
Total	1866.171	1893.473	1.46%

Figure 17 Volume Comparison

5.2.3 Efficiency

The metric for efficiency is annual fuel consumption, calculated using individual equipment efficiency values combined with a speed-condition profile that delineates the percent of time spent at various speeds and battle conditions, the engines' specific fuel consumption (SFC) at each loading, and an engine usage profile. The efficiency metric is described more fully in Chalfant and Chrystostomidis [2009].

First, the electrical loading for various ship conditions was determined. Based on Webster et al. [2007], ship service electrical loads for a future IPS small surface combatant are assumed to be 37MW. Of this 37MW, 21MW is estimated to be drawn by future radar loads. By using the ship service power fraction in ASSET of .485, a cruise ship service load of 7.76MW was calculated. For the battle conditions and wartime cruise the radar is assumed to be operating at full power. In the battle condition the assumption is made that a pulsed load is drawing 20MWs. The value for anchor loads was taken directly from ASSET. The final electric loading conditions are shown in Figure 18.

Condition	Calculation	Result
Battle	16MW x .485 + 21MW + 20MW	48.76 MW
Wartime Cruise	16MW x .485 + 21MW	28.76 MW
Peacetime Cruise	37MW x .485	17.95 MW
Anchor		2.40 MW

Figure 18 Electric Loading Conditions

Effective powering curves were created in Paramarine for both variants based on the ship weight and hull characteristics. To determine required propulsive power, effective power values were multiplied by the propulsive coefficient and assumed

transmission efficiency yielding required propulsion power as shown in Figure 19. The final results are displayed in Figure 20.

Propulsion Power								Units
Speeds	0	5	10	15	20	25	30	Knots
Four Generator	0	174	1,271	4,923	13,408	28,469	62,255	KW
Six Generator	0	174	1,276	4,952	13,499	28,694	62,832	KW

Figure 19 Required Propulsion Power

It was expected that fuel efficiency would have increased in the six generator case due to a more efficient operational profile (which it was) but due to the efficiency of the generators themselves it did not.

Fuel/Efficiency	4 Gen.	6 Gen.	Delta	Cost
Storage	1,674	1,690	+16	
Annual Use	26,335	26,455	+120	\$56K

Figure 20 Efficiency Comparison

5.2.4 Vulnerability

The results of the vulnerability metric are shown in Figure 21. They are categorized by blast radius and compare the four and six generator cases at each.

Vulnerability									
Blast Radius	2.6m			5.2m			10.4m		
	4 Gen	6 Gen	Diff	4 Gen	6 Gen	% Diff	4 Gen	6 Gen	% Diff
Average Vuln.	98.17%	98.50%	0.33%	92.80%	93.77%	0.97%	76.61%	77.52%	0.90%
# Hits <100%	23	21	-2	41	39	-2	64	64	0
Average Tier	7.17	7.20	0.03	6.29	6.32	0.03	4.30	4.30	0.00

Figure 21 Vulnerability Comparison

As expected the six generator case has scored higher than the four for all cases except the 10.4m radius where the tier value is the same. The 10.4m radius blast is so significant that the additional generators provide no advantage. The vulnerability resistance metric has distinguished between the two cases. When comparing the 2.6m radius case to the 5.2m radius case the added generators do more to influence the score when subjected to larger blast.

6 Conclusions

Decisions made during concept and definition phases of design are low cost efforts that have high leverage in the total ownership cost of the ship. Thus, trade-off studies performed during the earliest stages of design must use solid, repeatable metrics that give a true indication of the effects of design decisions on the entire ship.

Current survivability analysis of ships is a detailed, time consuming process. Often the results are achieved after significant design decisions have been made and changes to these can incur significant costs. The Navy's drive towards electric ships using integrated power systems is pushing ship designs to be more dependant on distributed systems [Doerry 2007b]. The higher reliance on distributed systems creates greater dependencies between systems. These dependencies create new challenges in the analysis of the ship's vulnerability.

Using this metric and design analysis tool in the early stages of ship design; a ship with higher vulnerability resistance may be designed at reduced cost. Early in the design process numerous trade-off studies may be performed allowing the designer to make informed decisions based on concrete vulnerability data.

6.1 Summary

The results of the four and six generator model were as expected by intuition. The greater number of PGMs incurred more weight and space but also led the ship to greater vulnerability resistance. The decrease in efficiency in the six generator case is not a product of the operational profile but a result of selecting less efficient PGMs. Because the results are reproducible and follow intuition, the tool can be applied to a greater number of scenarios.

6.2 Areas of Future Study

This tool has the ability to explore many possibilities in arrangements and architectures. The number of zones and zonal layouts can be explored as well as different bus architectures. In this case the number of PGMs was changed, this could be taken further to vary the number and location of both PGMs and PMMs or including a podded propulsor. Similar studies may be done on all the hull mechanical and electrical systems and weapons systems of the ship. The results of vulnerability showed sensitivity to the radius of the blast. Further investigation into blast size and vulnerability effects could prove interesting.

List of References

Chalfant, J. S. Computing the Vulnerability Metric for Electric-Drive Ship Simulations. Design Laboratory , MIT Sea Grant College Program, Report MITSG-DL-2010-01, April 2010.

Chalfant, J. S. and C. Chrysostomidis. Toward the development of an integrated electric ship evaluation tool. Proceedings of the 2009 Grand Challenge in Modeling and Simulation, GCSM '09, Istanbul, Turkey, July 13-16, 2009.

Cimino, Dominick. Marine Vehicle Weight Engineering. Society of Allied Weight Engineers, 2006

Doerry, N. H. Designing electrical power systems for vulnerability and quality of service. Naval Engineers Journal, 119(2):25–34, 2007a.

Doerry, N. H. Next Generation Integrated Power System (NGIPS) technology development roadmap. Ser 05D/349, Naval Sea Systems Command, Washington Navy Yard, DC, November 2007b.

Lewis, Edward V. Principles of Naval Architecture. Society of Naval Architects and Marine Engineers, Volumes I, II, and III, 1989.

The MathWorks. MATLAB and Simulink for technical computing. <http://www.mathworks.com/>.

Naval Sea Systems Command. Cost estimating handbook, 2005.

NSWCCD. ASSET User Manual, Version - 5.3, David Taylor Model Basin, Carderock Division, Naval Surface Warfare Center, May 1990.

QinetiQ. Paramarine Version 6.1. <http://www.qinetiq.com>.

Webster, J. S. H. Fireman, D. A. Allen, A. J. Mackenna, and J. C. Hootman. Alternative propulsion methods for surface combatants and amphibious warfare ships. Transactions of the Society of Naval Architects and Marine Engineers, 115, 2007.

Yarbrough, N R. and R. E. Kupferer. The joint command and control ship (JCC(X)) approach to survivability requirements development: total ship survivability assessment. In Proceedings of the Association of Scientists and Engineers 38th Annual Technical Symposium, Washington Navy Yard, DC, May 9, 2002.

Appendix A. Hull and Superstructure Import

A balanced ship design modeled in Advanced Surface Ship Evaluation Tool (ASSET) 5.3 used extensively by the US Navy was the starting point for the vulnerability analysis. This was chosen as a starting point to provide the user with flexibility to design a ship in a separate program and then import it for analysis. ASSET was also chosen to provide a useful tool for analysis of US Naval vessels.

The hull design was exported as an Initial Graphics Exchange Specification (IGES) file. An attempt was made to import this directly into Paramarine. There were errors during the import and the entire file was unable to be opened for analysis. This led to an intermediary program called Rhinoceros (Rhino) 4.0 which is primarily a Computer Aided Design (CAD) suite. The IGES file was opened in Rhino and the ship's hull lines and superstructure frame were able to be manipulated. In Rhino the EdgeSrf command, which creates a surface from two, three or four curves the Loft command, that creates a surface fit through selected profile curves that define the surface shape were primarily used. Surfaces were able to be fitted to these lines and frames creating the ship's hull and superstructure. Once completed the ship was exported as a Parasolid Transmit File.

The Parasolid file was then opened within Paramarine. The command Hull_surfaces3 was unsuccessful at creating a hull solid from this imported surface. Because of unresolved issues with matching tolerances of the hull the Parasolid could not be used directly in Paramarine. Because the hull was visible in Paramarine a different command was used to create the hull. The Quickhull Generation 1 command was used to model the port side of the visible hull solid. This was done by manipulating key points relating to the ship's hull including top and bottom of the bow, transom, parallel mid body if any and aft cut up. These points along with guide curves were manipulated to create the rough outline of the port hull. Next, other inputs were used in the CSA_Param command which creates curves of sectional area (CSA) for the ship. The inputs used were midship coefficient (C_m), prismatic coefficient (C_p) and displaced volume. These coefficients, points and curves were used in iteration to create a port hull. Once completed the Hull_surfaces3 command could then be used to mirror the hull creating a solid body representation of the entire hull.

To verify that the hull created in Paramarine is reasonably representative of that in ASSET a series of comparisons was run. The CSA and hydrostatic analysis of the Paramarine hull were compared with the ASSET model verifying that the hull was recreated in Paramarine with sufficient accuracy for the purposes of the analysis. It is anticipated that future versions of Paramarine will have better import capability for IGES files eliminating or simplifying this procedure.

There were no problems importing the superstructure directly as a Parasolid. It is believed that the tolerances for this structure are less demanding than that of the hull where detailed calculations and analysis will be required.

Once the hull and superstructure are transferred into Paramarine the deck and bulkhead layout needed to be transferred. The model in Paramarine has been linked to an Microsoft excel spreadsheet for ease of data transfer. The transverse bulkhead positions are entered into the sheet in Meters from amidships with positive values being forward and negative values being aft. The deck positions both in the hull and superstructure are entered in Meters above baseline.

Appendix B. Weight Parametric Analysis

With the design's hull and superstructure in Paramarine the ship's weights were next. Because there are items of interest that will be manipulated and relocated in Paramarine these must be removed from the generic lumping of weight groups that will remain static in this stage of the design.

Because ASSET organizes the ships weight using the Ship's Work Breakdown Structure (SWBS) this was the grouping used to organize the weights in Paramarine. To successfully estimate the weight to be included in Paramarine a set of parametric were used.

To determine the weights to be removed a list of components of interest must be generated.

These represent the majority of large components that will be variable within the Paramarine design. Weights and volumes for these objects will be entered and controlled directly in Paramarine. This is done so that changes made in the design will accurately be reflected in weight, volume and associated analysis. The majority of the ratios used came from [Cimino 2006]. These ratios are valid when comparing a parent ship design to a new ship design when the new ship characteristics are similar to that of the new design. In this case the parent and new ship are nearly identical with minor differences. These differences are used to determine new weights of the support equipment due to changes in main components.

The majority of the 100 weight group of hull structures was not manipulated when entered into Paramarine. Most ratiocination associated with this group is influenced by the primary ship dimensions of length, beam and depth. The foundations for the propulsion and electric plant were removed and included directly in PGMs and PMMs. The weight of the generator stacks were removed and manually calculated based on new locations. This was done so an addition or removal of PGMs in the design will correlate to the weight of the stacks. If changes are made to the number of transverse bulkheads then care should be taken to account for weights associated with transverse bulkheads and transverse framing. In this case the number of bulkheads remained fixed.

The 200 weight group containing propulsion plant equipment was heavily manipulated because this is a primary area of concern for the study and many of the components varied are accounted for here. In the 230 Propulsion Unit group the weight of the PMMs and PGMs were removed using detailed information on these components provided by ASSET. The remaining weights in this group were calculated using $W_n = W_p \times [SHP_n / SHP_p]$. For 240 Shafting and Propulsion the weight of the shafting was completely removed. The shafts will be controlled in Paramarine. This must be done because as the designer relocates the PMMs in the ship the shaft length must change to cover the distance to the propulsor. The propeller weight remained in the lumped sum because this component will remain unchanged and have a fixed location. The uptakes for the gas turbines were removed from the 250 Support System group. The remaining weights in

250 as well as 260 Propulsion Support and Lube Oil and 290 Special Purpose were calculated using $W_n = W_p \times \sqrt{[SHP_n / SHP_p]}$.

The 300 weight group Electric Plant is the next one to have a large portion of components removed. The Switch Gear and Panels 324 were completely removed. 321 Ship Service Power Cable was partially removed and adjusted. Detailed information from ASSET was used to determine the weights of cabling associated with all components upstream of the PCM-1As. This weight was removed from the total of 321 to give a value of all cabling within zones that was not being modeled in Paramarine. This remaining cabling was calculated by $W_n = W_p \times [KW_n / KW_p]$. This same ratio was used for the remaining components in this group because the assumption that CN, LBP and ship's complement are remain constant.

Weight group 400, Command and Surveillance was left unchanged and brought directly into Paramarine. Although this group does contain components that are modeled in Paramarine and are analyzed in the survivability metric the weights and centers of gravity have been assumed to remain constant. These objects when modeled in Paramarine have a size associated to determine damage from a blast radius but no individualized weight.

Cooling Water 532 was the only section of weight group 500 Auxiliary Systems to be recalculated. The ratio that was for the majority of the electrical systems was also used here $W_n = W_p \times [KW_n / KW_p]$.

Outfit and Furnishings 600 was not changed in. This was justified because crew size and the ship dimensions remain constant.

The 700 weight group Armament is controlled in the same way as 400 Command and Surveillance and entered directly into Paramarine.

Once new values for ship weights are obtained the resistance and powering are recalculated. If the powering changes then new values for weights must be brought into Paramarine again. This is required because the ratiocination for support and auxiliary systems not directly being manipulated are largely based on SHP and installed power of the ship.

Appendix C. Variable Component Positioning

Electrical System

The PGMs were placed along with the AC/DC converters for each generator. The information for the dimensions and weight of these objects was retrieved from the ASSET model. These objects were placed in the hull in the same location as indicated in ASSET.

Two PCM-1As were placed in each zone to provide power to the vital and non-vital loads within the zone. The weights and dimensions for these were determined from the estimate of the zonal loading and weight/power estimates. The locations of these were not given in ASSET with sufficient detail so a reasonable layout was chosen. In zone 1 and 4 the two were separated longitudinally as much as possible. In 2 and 3 there was limited longitudinal separation but the fore and aft separation was alternated through all 4 zones.

Cable ways were created in the overheads of the machinery spaces on the port side and just above the deck of these spaces on the stbd side. These were used to preferentially route cabling in Paramarine.

Switches were placed between electrical zones and were used in the calculation of connectivity between loads.

Propulsion Train

For ease of calculation rectangular objects were used to model all objects including the sonar sphere, mast, propellers and shafts.

The propulsor location is entered into Paramarine from ASSET. The weight is not of importance because the assumption is made that the propulsor will not be changed at this stage of design, therefore weight will be accounted for in the 200 Ship Work Breakdown Structure (SWBS) input later. The location of the propulsor is required for the calculation of shaft length between the propulsor and the PMMs. The location of the propulsor hub must be entered in relation to the intersection of the aft perpendicular and the design waterline.

Shaft information is then required to give an accurate calculation of shaft weight and moment. Area and density along with length to are used to calculate the weight in Paramarine.

The size, weight and location of the PMMs is originally obtained from the ASSET model and modeled in Paramarine. No specific data in ASSET was given for location of the main inverters for the PMMs. The location was chosen close to the PMMs to minimize cable routing and weight. Additionally for survivability purposes the PMM cannot operate without the inverter and vice versa so adjacent location does not compromise this.

A portion of the propulsion train was already set up from the ASSET outputs including the PMMs, Shafting and propulsor. The remaining steering equipment required was the rudders. Two rudders were placed port and stbd from the location and size information in the ASSET output. The assumption is made that

the steering control equipment is located close enough to the rudders that they would be compromised if the associated were damaged. Therefore this equipment was not modeled.

Damage Control

The fire pumps were placed within the ship using approximately equal spacing fore and aft with a pump on port and stbd. Eight pumps were used to provide sufficient redundancy for the damage control equipment. The assumption is made that there is sufficient electrical distribution that if the pump survives a hit there is adequate power available as well as suction and distribution piping for the water.

Appendix D. Combat Systems Positioning

Combat systems also need to be modeled. This information is not presented in the ASSET model for classification reasons so reasonable assumptions were made about the locations. The weight was not modeled individually because it is already accounted for in the Paramarine model. Geometry and size information was retrieved from unclassified data freely available on the internet. The locations selected for the point defense systems were just forward of the bridge and just forward of the flight deck. These locations were selected to provide maximum line of sight to the horizon given the interference of the mast, superstructure and weapon systems located topside. The assumption is also made that if the weapon remains undamaged that there is power available from at least one source.

For communications the assumption is made that if the mast is undamaged then the communications arrays are functional. The mast is modeled with a height of 10 meters and a base of 8x8 meters. The bridge is considered the origin point of communications and is modeled to house the control equipment.

For all the combat systems it is assumed that there are four computer center cabinets distributed throughout the ship. These cabinets have adequate communication through distributed networks that if one cabinet remains then the weapon systems controlled by these will still continue to function. The systems controlled are the vertical launching system (VLS), gun and torpedo systems. These cabinets were disturbed such that there is one far forward, one far aft, one centered between the machinery spaces and one in the superstructure.

For the torpedo system to operate in the ASW mission the sonar sphere, torpedo launchers and a computer cabinet must all be functional. The sphere is modeled on the bow of the ship. It is assumed that the sonar control equipment for this sensor is located sufficiently close inboard that a hit to the sphere would also compromise this equipment. The torpedo launchers are located port and stbd slightly aft of amidships to support a wide coverage area as well as spatial separation.

The gun system is employed for surface targets and gunfire support on ground targets. For the purposes of this exercise the surface mission is of concern because this is a higher likelihood of a threat. For the gun to perform its mission the gun must be intact, a radar and a computer cabinet.

The size of the radar system is modeled after the AN/SPY-1 radar that generally has four separate apertures pointing in four unique directions around the ship. For simplicity the system is modeled as a port and stbd aperture on the forward portion of the superstructure. To model the AN/SPY-1 a 3.7m diameter was assumed and 2m of separations between the forward and aft sensors. The control equipment for the radar is assumed to be inboard this bulkhead and is not modeled separately. The gun is positioned on the forward deck with its associated magazine local to the weapon.

The VLS system is laid out similarly to the gun system. The VLS can be used for anti-surface warfare (ASUW), anti-submarine warfare (ASW), ground

targets and anti-air warfare (AAW). For these purposes the mission of the VLS system is assumed to be only AAW and ASUW. The functional system is treated the same as the gun with the difference being the employed weapon. The VLS canisters are located within the hull breaching the deck just aft the gun.

For flight and boat operations the area aft of the superstructure is designated for this function. For simulation purposes damage to this area will prevent the deployment or retrieval of boats or aircraft.

Appendix E. Paramarine Iterations

Arrangements

Once the general ship is set up in Paramarine the major components of interest need to be arranged in the hull. For each of the desired components the designer needs information about the equipment including length, width, height and weight. These pieces of equipment including PMMs, PGMs, transformers, and rectifiers make up the equipment library. This equipment library can be expanded to include as many items as desired.

Within the design an equipment instance is created and linked to the equipment contained in the library. Once linked the equipment instance may be located anywhere within the ship by entering the corresponding X, Y and Z coordinate. It is at this stage that the designer can go into as much detail as desired by creating and using many components creating a high fidelity of system description. Once components are located, required connections are set up using desired cabling or piping.

Bulkhead Adjustment

After placing components the transverse bulkhead may be adjusted as necessary to accommodate the size and location of equipment. This is done by entering new X values to provide adequate clearance. For the purposes of this example the transverse bulkheads were not changed.

Floodable Length

To generate the curves of floodable length a margin line must be entered into Paramarine. This was done using the IGES file imported into Rhino. In this case the margin line was continuous. If the margin line for the ship is not continuous two deck's sheets may need to be combined into one sheet. The 1st deck was modeled using the lines from the IGES file. This sheet was exported as a Parasolid and imported into Paramarine. This sheet was then translated down three inches from the original location as required for a margin line. A pointer in the ship's envelope is made to the margin line sheet and floodable length may be calculated. For this case a 95% permeability was assumed.

By incorporating a floodable length check into the process, the designer may shift transverse bulkhead locations to fit required equipment. The designer may then perform an immediate validation that floodable length requirements are still met before proceeding with further design modifications. In each iteration of the design spiral of the floodable length criteria must be tested and met.

To perform the calculation of vulnerability data from Paramarine is exported into table format using Microsoft Excel. Direct links are set up so that changes to equipment and location within Paramarine are automatically updated

in the table. Matlab was used to read in the table and compute the vulnerability metric.

Appendix F. Damage Scenario

Generating hit points

Blast centers were determined as follows. The first step was to determine height. The design waterline and deck edge were selected for the first two planes of damage. The third height for the superstructure was obtained by taking the difference of the first two planes and adding it to the deck edge yielding values of 6.6m, 12.6m and 18.6m from baseline. The longitudinal positions were chosen to be at each of the transverse bulkheads. The blasts were centered on the skin of the ship.

To extract these values from Paramarine, planes needed to be generated at each Z height. This was accomplished by inserting two points linked to a variable height. The points should use the height as the Z variable and be at opposite corners fore and aft, larger than the ship's hull. The Rectangle operation on the plane was performed to create a rectangular plane that expands beyond the hull. The Subtract operation was performed between this plane and the hull solid, creating a 2D plane of the hull shape. This plane was selected and exported as a .DWL file. This file was opened in Microsoft excel. Once opened, the data can be plotted as X vs. Y on a scatter plot. It can easily be seen graphically which data points are used for formatting in the .DWL file type. The rows associated with these points were deleted. When viewing the final plot the image of the hull should be apparent. Once completed the height variable in Paramarine was changed and the data exported again. The results were 198 points of damage imposed along 3 different heights on the ship, the design waterline, the deck edge and super structure.