



## Calhoun: The NPS Institutional Archive

---

Theses and Dissertations

Thesis Collection

---

2008-12

# Stabilization system for camera control on an unmanned surface vehicle

Kandasamy, Jaya Kumar

Monterey, California. Naval Postgraduate School

---

<http://hdl.handle.net/10945/3832>



Calhoun is a project of the Dudley Knox Library at NPS, furthering the precepts and goals of open government and government transparency. All information contained herein has been approved for release by the NPS Public Affairs Officer.

**Dudley Knox Library / Naval Postgraduate School**  
**411 Dyer Road / 1 University Circle**  
**Monterey, California USA 93943**

<http://www.nps.edu/library>



**NAVAL  
POSTGRADUATE  
SCHOOL**

**MONTEREY, CALIFORNIA**

**THESIS**

**STABILIZATION SYSTEM FOR CAMERA CONTROL ON  
AN UNMANNED SURFACE VEHICLE**

by

Jaya Kumar Kandasamy

December 2008

Thesis Advisor:

Anthony J. Healey

**Approved for public release; distribution is unlimited.**

THIS PAGE INTENTIONALLY LEFT BLANK

<b>REPORT DOCUMENTATION PAGE</b>			<i>Form Approved OMB No. 0704-0188</i>
Public reporting burden for this collection of information is estimated to average 1 hour per response, including the time for reviewing instruction, searching existing data sources, gathering and maintaining the data needed, and completing and reviewing the collection of information. Send comments regarding this burden estimate or any other aspect of this collection of information, including suggestions for reducing this burden, to Washington headquarters Services, Directorate for Information Operations and Reports, 1215 Jefferson Davis Highway, Suite 1204, Arlington, VA 22202-4302, and to the Office of Management and Budget, Paperwork Reduction Project (0704-0188) Washington DC 20503.			
<b>1. AGENCY USE ONLY (Leave blank)</b>	<b>2. REPORT DATE</b> December 2008	<b>3. REPORT TYPE AND DATES COVERED</b> Masters' Thesis	
<b>4. TITLE AND SUBTITLE</b> Stabilization System for Camera Control on an Unmanned Surface Vehicle		<b>5. FUNDING NUMBERS</b>	
<b>6. AUTHOR(S)</b> Jaya Kumar Kandasamy		<b>8. PERFORMING ORGANIZATION REPORT NUMBER</b>	
<b>7. PERFORMING ORGANIZATION NAME(S) AND ADDRESS(ES)</b> Naval Postgraduate School Monterey, CA 93943-5000		<b>10. SPONSORING/MONITORING AGENCY REPORT NUMBER</b>	
<b>9. SPONSORING /MONITORING AGENCY NAME(S) AND ADDRESS(ES)</b> N/A		<b>11. SUPPLEMENTARY NOTES</b> The views expressed in this thesis are those of the author and do not reflect the official policy or position of the Department of Defense or the U.S. Government.	
<b>12a. DISTRIBUTION / AVAILABILITY STATEMENT</b> Approved for public release; distribution is unlimited.		<b>12b. DISTRIBUTION CODE</b>	
<b>13. ABSTRACT (maximum 200 words)</b>  SeaFox is an unmanned surface vehicle (USV) primarily used for maritime security operations. Currently, a remotely operated vision based camera is used to track a particular target whilst the USV approaches the intended target. While the USV is in motion, the hydrodynamic forces and mechanical vibrations makes it difficult for the operator to lock on to the target at all times.  This thesis addresses this issue through the development of a self compensated motion controller that uses geo-pointing to track and lock onto a target at all times. The disturbance data as captured by the onboard IMU sensor is used to establish parameters for the compensator. The compensated pan tilt angles are fed to the vision based camera through a PID controller.  The controller developed will enable the vision based camera system to autonomously track the intended target independently of the motion of the USV.			
<b>14. SUBJECT TERMS</b> Unmanned Surface Vehicle, USV, Geo-pointing, Compensator, Vision based camera, Autonomous tracking.			<b>15. NUMBER OF PAGES</b> 51
			<b>16. PRICE CODE</b>
<b>17. SECURITY CLASSIFICATION OF REPORT</b> Unclassified	<b>18. SECURITY CLASSIFICATION OF THIS PAGE</b> Unclassified	<b>19. SECURITY CLASSIFICATION OF ABSTRACT</b> Unclassified	<b>20. LIMITATION OF ABSTRACT</b> UU

THIS PAGE INTENTIONALLY LEFT BLANK

**Approved for public release; distribution is unlimited.**

**STABILIZATION SYSTEM FOR CAMERA CONTROL ON AN UNMANNED  
SURFACE VEHICLE**

Jaya Kumar Kandasamy  
Civilian, Singapore Technologies Kinetics Ltd  
B.Eng., Nanyang Technological University, 2001

Submitted in partial fulfillment of the  
requirements for the degree of

**MASTER OF SCIENCE IN MECHANICAL ENGINEERING**

from the

**NAVAL POSTGRADUATE SCHOOL  
December 2008**

Author: Jaya Kumar Kandasamy

Approved by: Anthony J. Healey  
Advisor

Knox T. Millsaps  
Chairman, Department of Mechanical and Astronautical  
Engineering

THIS PAGE INTENTIONALLY LEFT BLANK

## **ABSTRACT**

SeaFox is an unmanned surface vehicle (USV) primarily used for maritime security operations. Currently, a remotely operated vision based camera is used to track a particular target whilst the USV approaches the intended target. While the USV is in motion, the hydrodynamic forces and mechanical vibrations makes it difficult for the operator to lock on to the target at all times.

This thesis addresses this issue through the development of a self compensated motion controller that uses geo-pointing to track and lock onto a target at all times. The disturbance data as captured by the onboard IMU sensor is used to establish parameters for the compensator. The compensated pan tilt angles are fed to the vision based camera through a PID controller.

The controller developed will enable the vision based camera system to autonomously track the intended target independently of the motion of the USV.



THIS PAGE INTENTIONALLY LEFT BLANK

# TABLE OF CONTENTS

<b>I.</b>	<b>INTRODUCTION.....</b>	<b>1</b>
	A. <b>BACKGROUND .....</b>	<b>1</b>
	B. <b>PROBLEM FORMULATION .....</b>	<b>2</b>
	C. <b>OBJECTIVE .....</b>	<b>3</b>
	D. <b>SCOPE .....</b>	<b>3</b>
<b>II.</b>	<b>SYSTEM ARCHITECTURE .....</b>	<b>5</b>
	A. <b>SYSTEM OVERVIEW .....</b>	<b>5</b>
	B. <b>COORDINATE REFERENCE FRAMES AND TRANSFORMATIONS .....</b>	<b>6</b>
	1. <b>Inertial Coordinate Reference Frame.....</b>	<b>6</b>
	2. <b>Body Coordinate Reference Frame.....</b>	<b>6</b>
	3. <b>Gimbal Reference Frame .....</b>	<b>6</b>
	4. <b>Coordinate Transformations and Rotation Matrices.....</b>	<b>7</b>
	<i>a. Euler Angles [3].....</i>	<i>7</i>
	<i>b. Rotation Matrices.....</i>	<i>7</i>
	C. <b>GEO-POINTING .....</b>	<b>8</b>
	D. <b>PAN TILT CAMERA SYSTEM .....</b>	<b>10</b>
	1. <b>Camera Hardware Description .....</b>	<b>10</b>
	2. <b>Camera Software and Communication Protocol.....</b>	<b>11</b>
	E. <b>SENSORS .....</b>	<b>12</b>
	1. <b>IMU Sensor.....</b>	<b>12</b>
	2. <b>GPS.....</b>	<b>12</b>
<b>III.</b>	<b>SYSTEM MODEL .....</b>	<b>13</b>
	A. <b>OVERVIEW.....</b>	<b>13</b>
	B. <b>GEO-POINTING MODEL .....</b>	<b>14</b>
	C. <b>DISTURBANCE MODEL .....</b>	<b>15</b>
	D. <b>PAN TILT CAMERA MODEL.....</b>	<b>17</b>
	E. <b>PAN TILT COMMAND MODEL .....</b>	<b>18</b>
<b>IV.</b>	<b>SIMULATIONS AND RESULTS .....</b>	<b>21</b>
	A. <b>EXPERIMENTAL SET UP.....</b>	<b>21</b>
	B. <b>SIMULINK SIMULATIONS AND RESULTS .....</b>	<b>22</b>
	1. <b>IMU Data Verification.....</b>	<b>22</b>
	2. <b>Target Tracking .....</b>	<b>24</b>
	<i>a. Target Tracking without Disturbance.....</i>	<i>25</i>
	<i>b. Target Tracking with Disturbance .....</i>	<i>25</i>
<b>V.</b>	<b>CONCLUSIONS AND RECOMMENDATIONS.....</b>	<b>29</b>
	A. <b>CONCLUSIONS .....</b>	<b>29</b>
	B. <b>RECOMMENDATIONS.....</b>	<b>29</b>
<b>APPENDIX.....</b>		<b>31</b>
	A. <b>IMU PARAMETERS .....</b>	<b>31</b>

<b>B.</b>	<b>MATLAB FUNCTIONS .....</b>	<b>32</b>
<b>1.</b>	<b>MATLAB function: Alticam_cmd.m .....</b>	<b>32</b>
	<b>LIST OF REFERENCES .....</b>	<b>33</b>
	<b>INITIAL DISTRIBUTION LIST .....</b>	<b>35</b>

## LIST OF FIGURES

Figure 1.	UAV-USV collaborated MIO.....	1
Figure 2.	Video captures of a USV-UAV MIO collaboration experiment[1].....	2
Figure 3.	System architecture.....	5
Figure 4.	Relative vector of target with respect to USV in NED frame coordinates.....	9
Figure 5.	Relative vector of target with respect to USV in body frame coordinates.....	9
Figure 6.	Alticom 400 Camera System.....	10
Figure 7.	Honeywell HG1700 IMU.....	12
Figure 8.	System Simulink Model.....	13
Figure 9.	Simulink model to compute relative vector of target to USV in inertial frame.....	14
Figure 10.	Simulink model of disturbances measured by IMU.....	15
Figure 11.	IMU data acquisition Simulink model.....	16
Figure 12.	Simulink model to compute Euler Angles.....	17
Figure 13.	Simulink model to compute pan and tilt angles.....	17
Figure 14.	Simulink model of transformation matrix.....	18
Figure 15.	Simulink model to command Alticom camera.....	19
Figure 16.	Experimental setup.....	21
Figure 17.	Graph of roll angle against time.....	23
Figure 18.	Graph of pitch angle against time.....	23
Figure 19.	Graph of yaw angle against time.....	23
Figure 20.	Scenario layout for target tracking simulation.....	24
Figure 21.	Graph of pan/tilt angles against time for tracking without disturbance.....	25
Figure 22.	Graph of pan/tilt angles against time for tracking with roll disturbance.....	26
Figure 23.	Graph of pan/tilt angles against time for tracking with pitch disturbance.....	26
Figure 24.	Graph of pan/tilt angles against time for tracking with yaw disturbance.....	26

THIS PAGE INTENTIONALLY LEFT BLANK

## LIST OF TABLES

Table 1.	Altacam hardware communication settings.....	10
Table 2.	Outgoing packet header .....	11
Table 3.	Data field packet .....	11
Table 4.	Geodetic coordinates of USV and target .....	24

THIS PAGE INTENTIONALLY LEFT BLANK

## **ACKNOWLEDGMENTS**

I would like to thank Professor Anthony Healey for his kind guidance and immense contributions to this thesis. He has been a great source of inspiration and knowledge.

I would also like to give special thanks to Sean Kragelund for his contribution to the software implementation, Simulink model building tips and help in constructing the bench top that made possible the research work.



THIS PAGE INTENTIONALLY LEFT BLANK

# I. INTRODUCTION

## A. BACKGROUND

The Centre for Autonomous Unmanned Vehicle Systems Research (CAUVSR) at the Naval Postgraduate School (NPS) has been recently conducting research and experimentations on collaborative operations by an unmanned aerial vehicle (UAV) and an unmanned surface (USV) to support maritime interdiction operations (MIO). The UAV serve as a long-range sensor and navigational aid for the USV. Using the target location data from the UAV, the USV is able to intercept a target vessel and/or perform close-up visual inspection. This is shown in Figure 1.

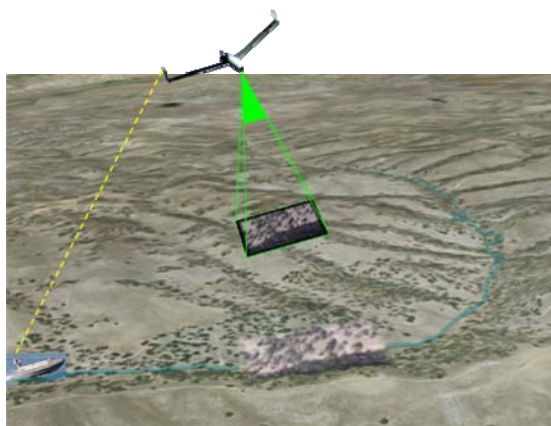

Figure 1. UAV-USV collaborated MIO

During a recent experiment performed during NAVSPECWARCOM system demonstration at San Clemente Island in February 2008, the ScanEagle UAV was used as the long range sensor for the SeaFox[1] USV which was required to autonomously intercept a high speed target vessel.

The ScanEagle uses its electro optical camera to locate the target vessel location. This position is then located by computation on the surface of the earth. This point known as the Sensor Point of Interest (SPOI) is then relayed to the SeaFox in real time. Based on the SPOI coordinates, the SeaFox will estimate the target vessel location and starts the

pursuit. During the pursuit and subsequent tracking of the target vessel, the daylight camera on the SeaFox provides imaging to the operator via a wireless network. This is shown in Figure 2. .



Figure 2. Video captures of a USV-UAV MIO collaboration experiment[1]

## B. PROBLEM FORMULATION

The experiment served as a successful proof of concept. The SeaFox was able to successfully track the target vessel. However, the experiment showed that there were two areas which required improvement and further study.

The first problem identified was the large variation in the SPOI data. The high noise in the data was attributed to the operating area and the limitation imposed on the

height of operation for the UAV. The noise in the SPOI data meant that small adjustments made in the UAV's camera pointing direction translated into larger target position changes on the surface.

The second problem identified was that the imaging provided by the camera onboard the SeaFox was unstable. This problem was mainly attributed to the wave motion which the SeaFox was subjected to as it pursued and tracked the target. The wave motion was in turn transmitted to the camera which resulted in unstable imaging for the operator.

From the above problems, it became clear that the SeaFox USV should not rely entirely on the target data provided by the UAV. It was desired that the USV use the initial target location provided by the UAV and thereafter pursue and track the target with its own sensors. It was also desired to have a stable video imaging for proper target inspection. This meant that the camera system will require some sort of compensator system to cancel the wave effects that causes destabilization of the video imaging.

This thesis looks into the above areas of research, providing the USV a means of tracking the target vessel based on initial target coordinates as well as to be able to cancel out the wave effect for stable video imaging.

### **C. OBJECTIVE**

The objective of this research is to design and develop a camera control system that is able to point the pan-tilt camera unit at the target in real time, given the geodetic location of the target and taking into account the movements of the boat and the external disturbances from the water waves

### **D. SCOPE**

The scope of this thesis covers the following areas:

- Using an Inertial Measurement Unit(IMU) sensor to measure USV motion and wave effects.

- Computation of the required pointing angles to track target and to cancel wave motion in the camera.
- To design a compensator to provide a stabilized video imaging device.
- To command camera to pan and tilt to the required angles.

## II. SYSTEM ARCHITECTURE

### A. SYSTEM OVERVIEW

The overall system is divided into two segments for ease of design. The first segment looks at the IMU data that the system reads in real time. The data from the IMU provides the accelerations of the USV body in three orthogonal axes as well as rotational rates about these axes. The overall system architecture is shown below in Figure 3. The rotational rates from the IMU is corrected for the rotation of the earth. These rate are then used to compute the Euler angles with reference to the USV body frame. The Euler angles computed reflect the effect of the waves directly on the body of the USV.

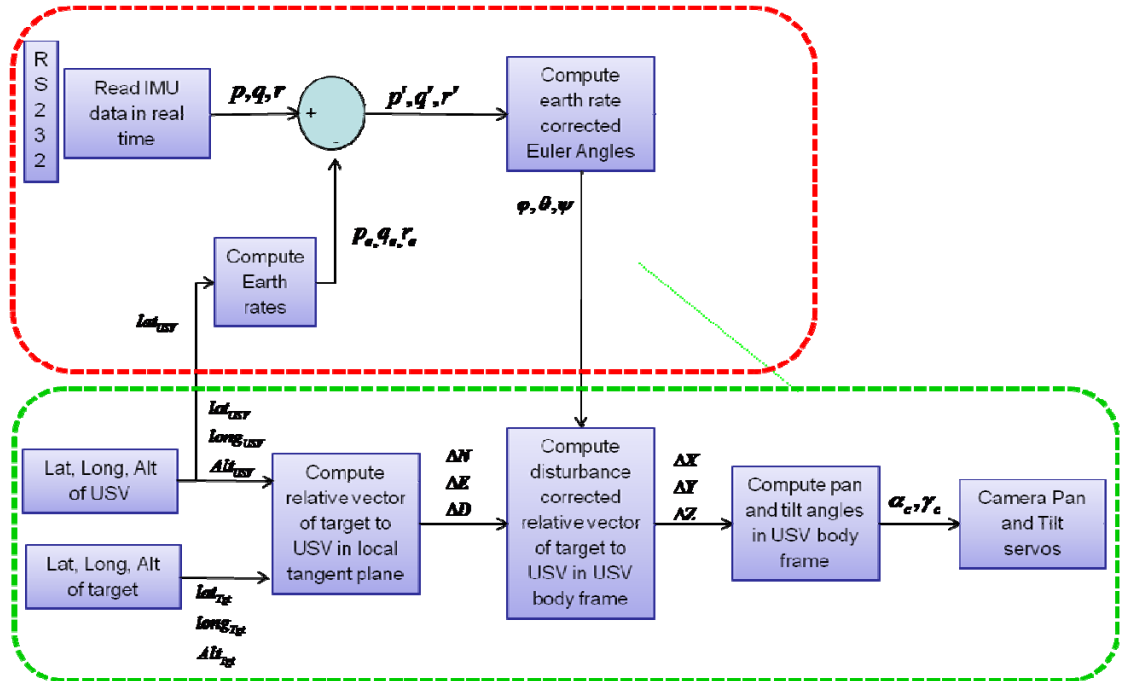

Figure 3. System architecture

The second segment calculates the pointing angles required by the camera and sends the required commands to pan and tilt the camera so as to obtain the proper view of the target. As shown in Figure 3., the camera pan and tilt commands are computed from the geodetic location of the target and the USV. The latitude, longitude and altitude of

both the target and the USV are converted to coordinates in the local tangent plane, which in this case is taken as the North-East-Down(NED) coordinate system. Once the coordinates are calculated in the NED frame, the relative vector of the target with respect to the USV is computed. This relative vector is then further transformed into the relative vector in the USV body frame coordinate system. Knowing the relative vector of the target with respect to the USV, the required command pan and tilt angles are then computed for the camera to point to the target having taking into account the disturbances of the waves on the camera.

## **B. COORDINATE REFERENCE FRAMES AND TRANSFORMATIONS**

### **1. Inertial Coordinate Reference Frame**

The local tangent plane is used to represent the inertial coordinate system in this report. In using the local tangent plane, a necessary assumption of a flat earth has been made. This is a valid assumption, as the target and the USV are within an area where the curvature of the earth does not come into play. North-east-down (NED) is used as right handed orthogonal axes to represent the coordinate system in the local tangent plane. The north corresponds to the x-axis, the east corresponds to the y-axis and down corresponds to the z-axis. The north axis aligns with the Northing of the earth; east axis aligns with the Easting of the earth, and down points downward to the center of the earth.

### **2. Body Coordinate Reference Frame**

The USV body coordinate frame is a right handed orthogonal system with its origin at the center of gravity of the USV. The x-axis of the frame is aligned with the fore direction of the USV, the y-axis is aligned towards the starboard side of the USV and the z-axis is aligned downward towards the center of the earth.

### **3. Gimbal Reference Frame**

The gimbal reference frame is a right handed orthogonal coordinate system similar to that of the body frame coordinate system. The origin of this reference frame is

the intersection point of the axis of pan and the axis of tilt. The x-axis ,y-axis and the z-axis are aligned with the respective axes of the body frame. For simplification, the origin of the gimbal reference frame and the origin of the body frame is taken to be at the same location.

#### 4. Coordinate Transformations and Rotation Matrices

##### a. Euler Angles [3]

The angular orientation of one coordinate system can be defined with respect to another coordinate system using the three Euler angles. The Euler angles,  $\Phi$ ,  $\theta$ , and  $\psi$ , describe the roll, pitch and yaw of the USV in the inertial frame respectively. The use of the Euler angles to describe the relative orientation of two coordinate frames is simple and effective as long as the pitch angle,  $\theta$ , does not approach  $\pm 90^\circ$ . The pitch angle of the USV and the camera do not approach this singularity and thus will not pose a problem. However, should there be a need to track objects above the USV in which a pitch angle approaching  $90^\circ$  may be required, then the use of quaternion will be more appropriate.

##### b. Rotation Matrices

The orientation of the USV in any frame is defined by its position, given by a [3X1] position vector, and its angular orientation, given by a [3X3] rotation matrix. The rotation matrices for rotation about each axis is given by the following equations [2]:

$$\begin{bmatrix} x' \\ y' \\ z' \end{bmatrix} = R_\psi \begin{bmatrix} x^i \\ y^i \\ z^i \end{bmatrix} = \begin{pmatrix} \cos \psi & \sin \psi & 0 \\ -\sin \psi & \cos \psi & 0 \\ 0 & 0 & 1 \end{pmatrix} \begin{bmatrix} x^i \\ y^i \\ z^i \end{bmatrix} \quad (1)$$

$$\begin{bmatrix} x'' \\ y'' \\ z'' \end{bmatrix} = R_\theta \begin{bmatrix} x' \\ y' \\ z' \end{bmatrix} = \begin{pmatrix} \cos \theta & 0 & -\sin \theta \\ 0 & 1 & 0 \\ \sin \theta & 0 & \cos \theta \end{pmatrix} \begin{bmatrix} x' \\ y' \\ z' \end{bmatrix} \quad (2)$$



$$\begin{bmatrix} x^b \\ y^b \\ z^b \end{bmatrix} = R_\varphi \begin{bmatrix} x'' \\ y'' \\ z'' \end{bmatrix} = \begin{pmatrix} 1 & 1 & 0 \\ 1 & \cos \varphi & \sin \varphi \\ 0 & -\sin \varphi & \cos \varphi \end{pmatrix} \begin{bmatrix} x'' \\ y'' \\ z'' \end{bmatrix} \quad (3)$$

The above three equations are combined to form a single rotational matrix to transform coordinates from the inertial frame to the body frame. This is shown in the following equation [4]:

$${}^B R = R_\varphi R_\theta R_\psi = \begin{pmatrix} \cos \psi \cos \theta & \sin \varphi \cos \theta & -\sin \theta \\ \cos \psi \sin \theta \sin \varphi - \sin \psi \cos \varphi & \sin \psi \sin \theta \sin \varphi + \cos \psi \cos \varphi & \cos \theta \sin \varphi \cos \theta \\ \cos \psi \sin \theta \sin \varphi + \sin \psi \sin \varphi & \sin \psi \sin \theta \cos \varphi - \cos \psi \sin \varphi & \cos \varphi \end{pmatrix} \quad (4)$$

Using the rotational matrix, the coordinates in the body frame is obtained as in the following equation:

$$\begin{bmatrix} x^b \\ y^b \\ z^b \end{bmatrix} = {}^B R \begin{bmatrix} x^i \\ y^i \\ z^i \end{bmatrix} \quad (5)$$

### C. GEO-POINTING

The relative vector of the target vessel with respect to the USV is termed as geo-pointing in this report. Geo-pointing is obtained in the local tangent plane using the N-E-D coordinates. In order for geo-pointing to take place, the latitude, longitude of both the target and the USV must be known. In addition, the latitude and longitude of a point of origin taken to be within the vicinity of both the target and the USV must be known. Using the above mentioned three points, a relative vector of the target with respect to the USV is obtained as illustrated in Figure 4.

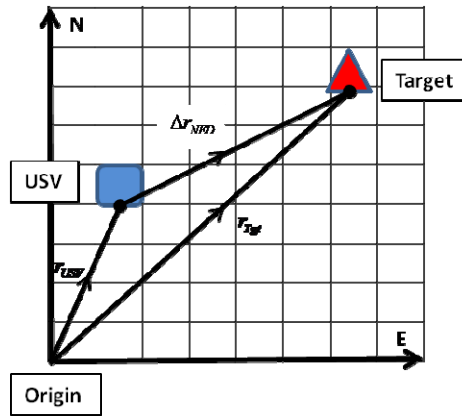

Figure 4. Relative vector of target with respect to USV in NED frame coordinates

The relative vector,  $\Delta r$ , in the NED coordinates is obtained as follows:

$$\Delta r_{NED} = r_{Tgt} - r_{USV} \quad (6)$$

However, the relative vector as obtained in the local tangent plane will not give the true angle that the camera will need to point to so as to track the target. The heading of the USV has to be taken into account so that the true angle of pointing may be obtained. In order to do this, the relative vector of the target with respect to the USV must be obtained in USV body frame of coordinates. Figure 4 below shows the true pan angle,  $\alpha$ , that will be obtained using the relative vector in the USV body frame coordinates.

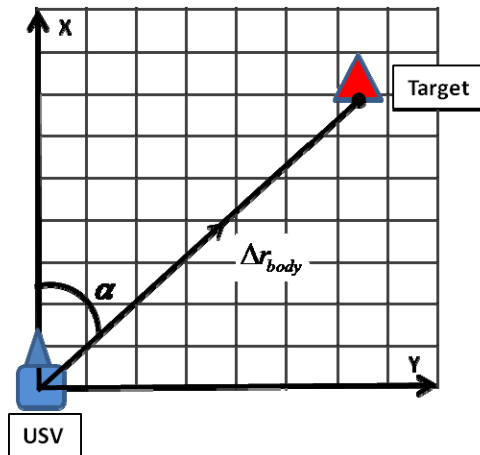

Figure 5. Relative vector of target with respect to USV in body frame coordinates

## D. PAN TILT CAMERA SYSTEM

### 1. Camera Hardware Description

The camera system that is used in the USV is the turret mounted Alticam 400[5]. This is a small lightweight turret mounted camera system that is inertially stabilized. This allows the camera to point accurately at the target independent of the position and orientation of the USV. The camera incorporates advanced stabilization logic that is able to filter the vibrations of the USV.

The E-640 electro optics camera onboard uses a 640 x 480 pixel color CCD sensor. The camera is able deliver video at 30 frames per second and has a 25x optical zoom. Figure 6. shows the Alticam camera system.



Figure 6. Alticam 400 Camera System

The Alticam camera system has a bandwidth of 20 Hz. This limits the rate at which commands can be sent to the camera system. Table 1 below shows the hardware communication settings for the camera system.

Type	SW version	bps	Selectable?	Data	Stop bit	Parity	HW control
AltiCam 04	195	57,600	NO	8	1	N	None

Table 1. Alticam hardware communication settings

## 2. Camera Software and Communication Protocol

The Alticam camera system uses the Insitu Seascan protocol for the purpose of communication. Messages to and from the camera system are composed as follows:

- Header field of 9 bytes
- Data field of 7 bytes
- Cyclic redundancy check (CRC) field of 2 bytes

The header field which contains 9 bytes is necessary as it allows the Alticam camera system to synchronize with the incoming message. The header fields are always the same for messages being sent to the camera system. Table 2 shows an example of the header that is used in this thesis. The data shown in the table is in hexadecimal.

<b>H0</b>	<b>H1</b>	<b>H2</b>	<b>H3</b>	<b>H4</b>	<b>H5</b>	<b>H6</b>	<b>H7</b>	<b>H8</b>
0x55	0xAA	0x07	0x4D	0x00	0x00	0x00	0x00	0x00

Table 2. Outgoing packet header

The data field for the camera system made up of 7 bytes contains commands that are sent to the camera for it to perform a particular function. In this thesis, the commands being sent to the camera are the pan angle command and the tilt angle command. The syntax and the required protocol is shown in Table 3 below.

<b>D0</b>	<b>D1</b>	<b>D2</b>	<b>D3</b>	<b>D4</b>	<b>D5</b>	<b>D6</b>
47	51	00	op	00	00	uv

Table 3. Data field packet

The data shown in Table 3 is in hexadecimal. The value of “op” and “uv” represents the pan angle command,  $\alpha_{cmd}$  and tilt angle command,  $\gamma_{cmd}$  in hexadecimal respectively. In order for the camera to steer to the correct pan angle and tilt angle, the correct values of “op” and “uv” will have to be evaluated as shown below in the following equations:

$$op = \left( \frac{\alpha_{cmd} \times 10000}{256} \right) + 128 \quad (7)$$

$$uv = \left( \frac{\gamma_{cmd} \times 10000}{256} \right) + 128 \quad (8)$$

The values as evaluated by the equations above will then have to be converted to hexadecimal before sending to the camera system. The syntax for other commands can be found in [5].

## E. SENSORS

### 1. IMU Sensor

The Inertial Measurement Unit (IMU) used in this thesis is the Honeywell HG 1700. The HG1700 shown in figure 5 is a low cost ring laser gyroscope based IMU.



Figure 7. Honeywell HG1700 IMU

The IMU outputs the rotational rates in the inertial frame, p, q and r. these rates measures the rotation of the body with respect to the orthogonal x,y and z axes. The IMU also outputs the acceleration in the three orthogonal axes, Ax, Ay and Az. The IMU is mounted at the center of gravity of the USV so that it able to measure the rotation of the USV about its center of gravity. A detailed of the IMU parameter list is attached in appendix A.

### 2. GPS

The Global Positioning System(GPS) on board the Seafox USV provides its latitude and longitude required for the calculation of the camera pointing angles.

### III. SYSTEM MODEL

#### A. OVERVIEW

The main focus of this thesis was to implement control systems in Simulink. Figure 8. shows the Simulink model of the overall system.

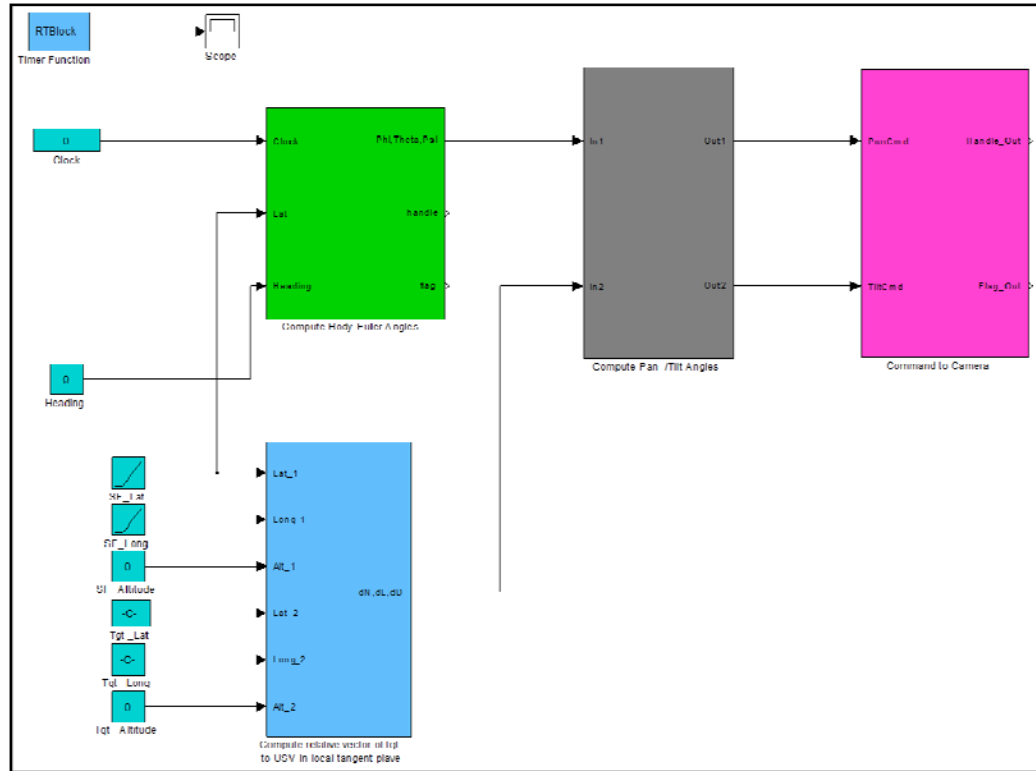

Figure 8. System Simulink Model

The geo-pointing block computes the relative vector of the target with respect to the USV in the inertial frame based on the latitude, longitude and altitude of the USV and the target. The output of this model is then passed onto the pan tilt command block.

The disturbance model computes the disturbances due to the waves on the USV. This model reads the IMU data which measures the disturbances on the USV. The output of this block, the Euler angles in the body frame, is passed on to the pan tilt command block

The pan tilt command block mainly computes the required pan and tilt angles required to track the target, taking into account disturbances on the USV. The output of this block, pan command angle, and tilt command angle is passed onto the pan tilt camera model.

The pan tilt camera model uses the pan and tilt command angles, and converts it into a message for communication with the camera system.

In order for the model to read data in real time, the RTBlock is used to ensure the simulation runs in real time. The simulation is run with a step size of 0.01s.

## B. GEO-POINTING MODEL

The geo-pointing model computes the relative vector of the target with respect to the USV. Figure 9. shows the structure of the geo-pointing model.

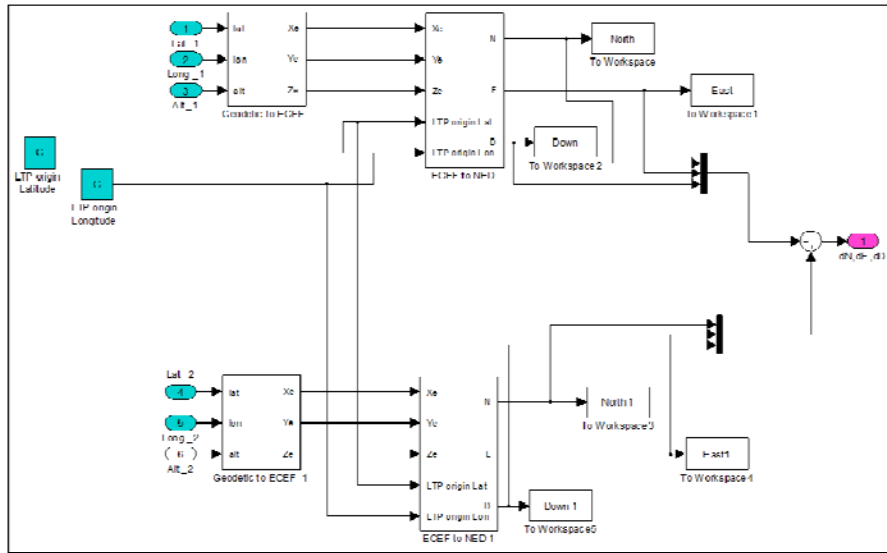

Figure 9. Simulink model to compute relative vector of target to USV in inertial frame

The latitude, longitude and altitude is used to compute the NED coordinates of the USV and target respectively. This model requires a point of origin. The origin point is taken to be within the vicinity of the operation so as to reduce localization errors. The difference between the target NED coordinates and the USV NED coordinates produces the required relative vector in the inertial frame.

### C. DISTURBANCE MODEL

The disturbance model basically measures the disturbances on the USV and thus the camera platform using the onboard IMU. The Simulink model of the disturbance model is shown in Figure 10.

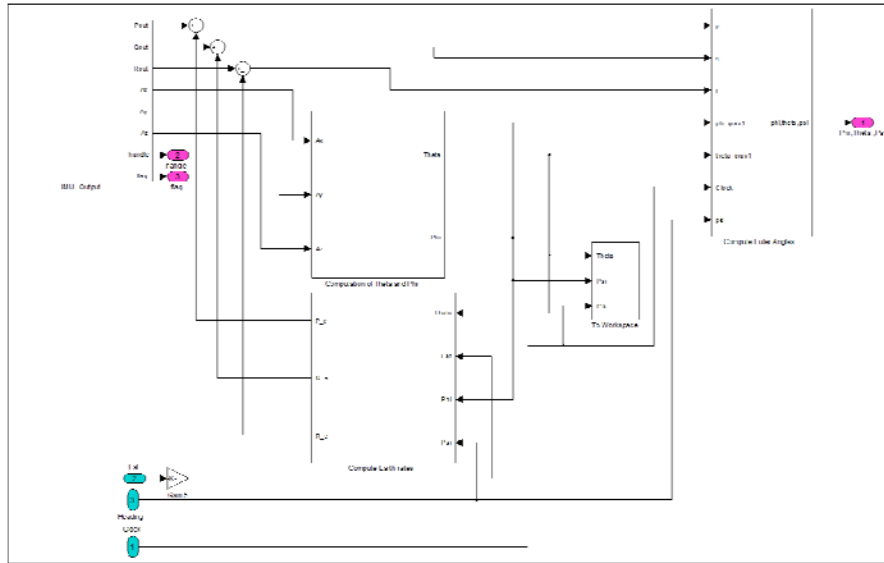

Figure 10. Simulink model of disturbances measured by IMU

The disturbance measurement data from the IMU is read by a RS232 blockset. The data is read in binary form via a RS232 port. The output of the IMU is then converted to decimal values. Due to vibrations, the signal is noisy and thus a low pass third order butterworth filter is used to produce a smoother signal. The model is shown below in Figure 11.



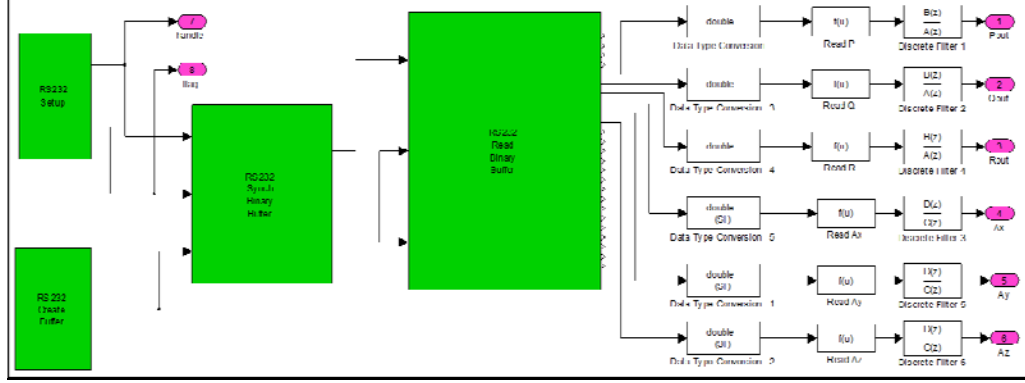

Figure 11. IMU data acquisition Simulink model

The acceleration values,  $A_x$  and  $A_y$ , from the IMU is used to compute the initial gravity based roll,  $\phi_{grav}$ , and pitch angle,  $\theta_{grav}$ . The computations of these angles are shown in the following equations [3]:

$$\theta_{grav} = \sin^{-1}\left(\frac{A_x}{g}\right) \quad (9)$$

$$\phi_{grav} = \sin^{-1}\left(\frac{A_y}{g \cos \theta}\right) \quad (10)$$

$\phi_{grav}$  and  $\theta_{grav}$  angles are then used to compute the earth correction for the rotational rates,  $p$ ,  $q$  and  $r$ . the corrected rotational rates and  $\phi_{grav}$  and  $\theta_{grav}$  angles are used to compute the Euler angle rates as shown in equation 11 [2].

$$\begin{bmatrix} \dot{\phi} \\ \dot{\theta} \\ \dot{\psi} \end{bmatrix} = \begin{pmatrix} 1 & \sin \phi \frac{\sin \theta}{\cos \theta} & \cos \phi \frac{\sin \theta}{\cos \theta} \\ 0 & \cos \phi & -\sin \phi \\ 0 & \sin \phi \frac{1}{\cos \theta} & \cos \phi \frac{1}{\cos \theta} \end{pmatrix} \begin{bmatrix} p \\ q \\ r \end{bmatrix} \quad (11)$$

Once the Euler angle rates have been determined, the Euler angles are obtained by integrating the Euler angle rates, taking  $\phi_{grav}$  and  $\theta_{grav}$  angles as initial values for the integration. The model illustrating the above is shown in Figure 12.

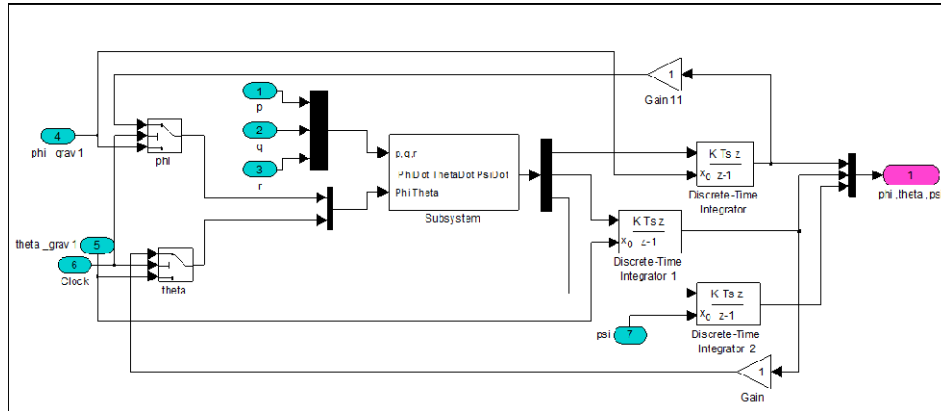

Figure 12. Simulink model to compute Euler Angles

#### D. PAN TILT CAMERA MODEL

The pan tilt camera model primarily computes the pan and tilt angles that will be required to point the camera at the target taking into account disturbances on the USV and the camera platform. Figure 13. shows the Simulink model.

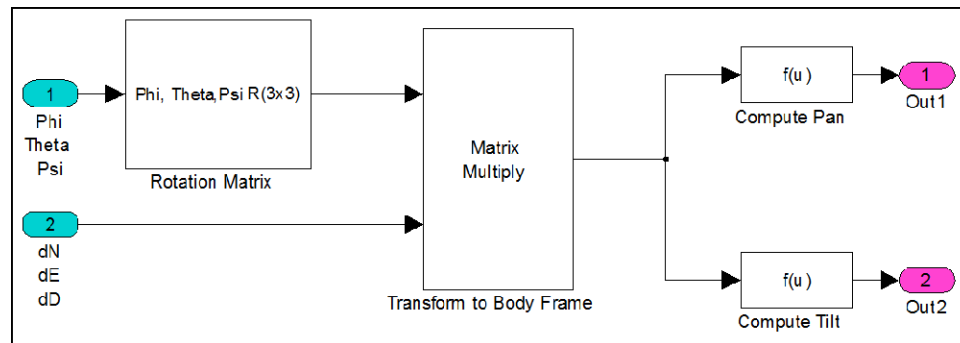

Figure 13. Simulink model to compute pan and tilt angles

Using the Euler angles from the disturbance model, a  $[3 \times 3]$  rotational matrix is obtained as shown below in Figure 14.

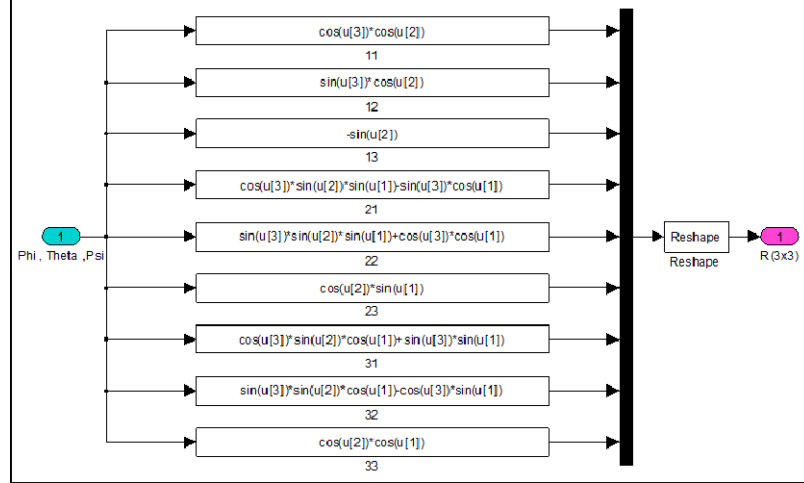

Figure 14. Simulink model of transformation matrix

This matrix is then multiplied with the output from the geo-pointing model to obtain the relative vector of the target with respect to the USV in body frame coordinates as shown in the following equation:

$$\begin{bmatrix} dx \\ dy \\ dz \end{bmatrix} = R_{\varphi, \theta, \psi} \begin{bmatrix} dN \\ dE \\ dD \end{bmatrix} \quad (12)$$

The rotation matrix  $R_{\varphi, \theta, \psi}$  is given by equation 4 previously. The relative vector as obtained in equation 12 gives the position of the target with respect to the USV without having to take into account the heading of the USV. The pan angle,  $\alpha$ , and tilt angle,  $\gamma$ , required by the camera platform is given by the following equations:

$$\alpha = \tan^{-1} \left( \frac{dy}{dx} \right) \quad (13)$$

$$\gamma = \tan^{-1} \left( \frac{dD}{\sqrt{(dx)^2 + (dy)^2}} \right) \quad (14)$$

## E. PAN TILT COMMAND MODEL

The pan tilt command model uses the command pan and tilt angles and places them in the message being sent to the camera as shown in Figure 15.

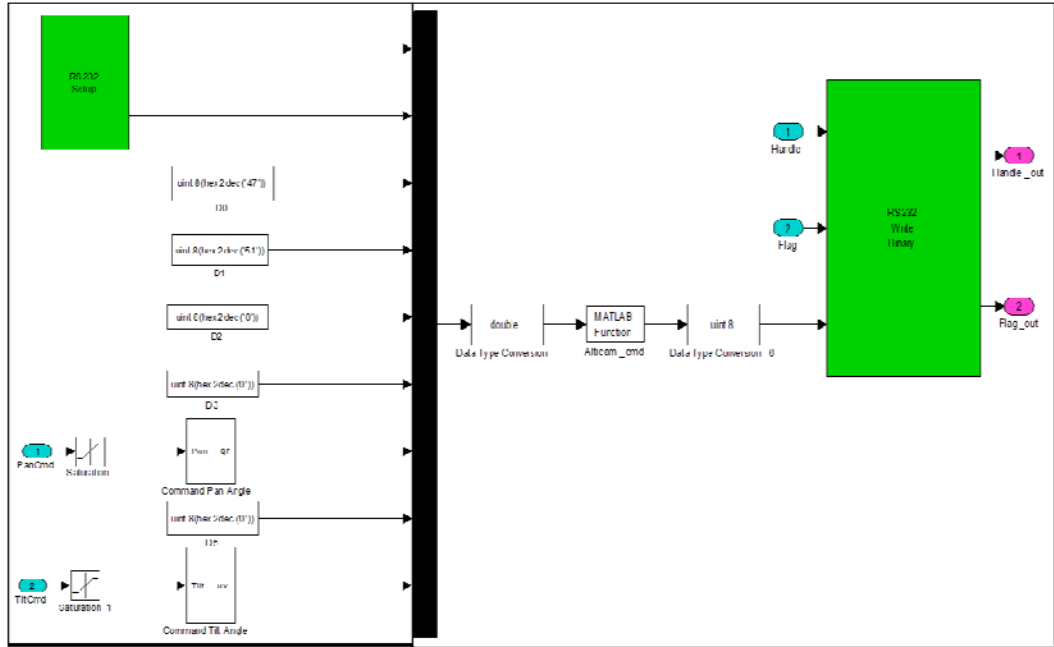

Figure 15. Simulink model to command Alticom camera

The data values for the message are sent to the Alticom\_cmd.m matlab function. The matlab function forms the message in the required communication protocol and sends it out to the camera. The Alticom\_cmd function is attached in Appendix B.

THIS PAGE INTENTIONALLY LEFT BLANK

## IV. SIMULATIONS AND RESULTS

### A. EXPERIMENTAL SET UP

In order to facilitate the experimentation of the control system, it was necessary to have the Seafox USV to be able to run the simulations. However, due to the unavailability of the Seafox, a bench top experimental setup was constructed to simulate the actual Seafox platform. The experimental setup is shown below in Figure 16.

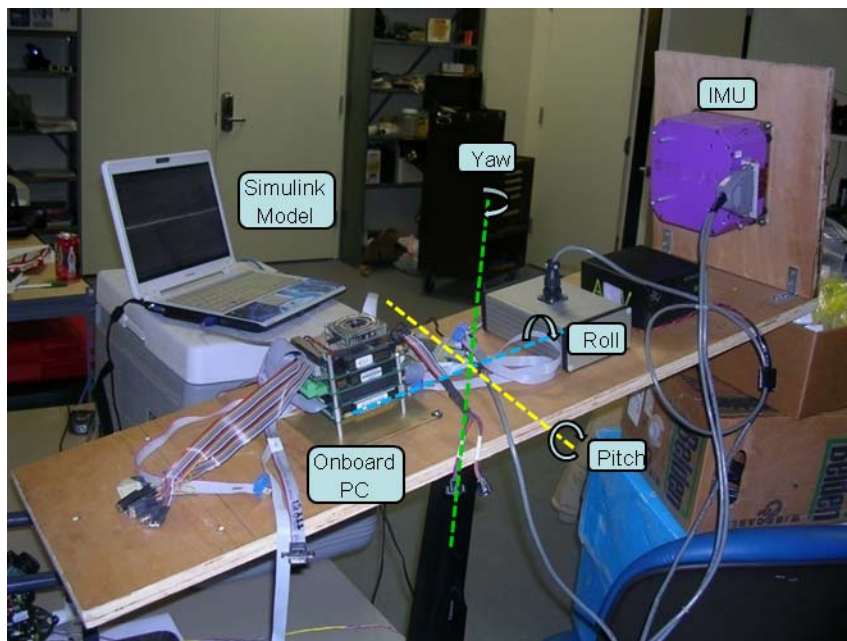

Figure 16. Experimental setup

The platform that was constructed is made in such a way that it is able to roll, pitch and yaw about the x, y and z axes respectively as shown in Figure 16. The output from the IMU is fed to the Simulink model on a computer via RS232 port. The IMU outputs a series of data. For this thesis, the data of interest is the gyro rotation rates, p, q and r as well as the accelerometer values,  $A_x$ ,  $A_y$  and  $A_z$ . The Simulink model is set up to read the incoming data at a sampling rate of 100 Hz which is the maximum data output rate from the IMU.

## **B. SIMULINK SIMULATIONS AND RESULTS**

In this section, the report will look at the various simulations that were run to test the control system. The simulation results for each simulation is reviewed and analysed.

### **1. IMU Data Verification**

The main aim of analyzing the IMU data was to obtain the body frame rotational Euler angles which can then be used as a disturbance signal to correct for the pan and tilt angle commands to the camera. The data from the IMU is based in the inertial frame of reference. Therefore, to be able to use the IMU data, it has to be further refined to obtain the rotational angles of the USV and thus the camera platform in the body reference frame. These angles, known as the integrated Euler angles is to be used to run further simulations. However, in order to validate the data received from the IMU, it was desired to compare the gravity based roll and pitch angles with the integrated Euler angles.

The experiment to verify the IMU data was done in three steps. The platform was firstly rotated sideways about the x-axis to simulate the roll on the USV. The IMU data were then used to plot a graph of roll angle,  $\phi$ , with time for both the integrated roll angle and the gravity based roll angle. The plot for the comparison of the roll angle is shown in Figure 17. Secondly, the platform was rotated about the y-axis to simulate the pitch on the USV. The resulting integrated pitch angle and the gravity based pitch angle is plotted as shown in Figure 18. Finally, the platform was rotated about the z-axis to simulate the yaw of the USV. In this case, only the integrated yaw angle,  $\psi$  is obtained and is plotted as shown in Figure 19.

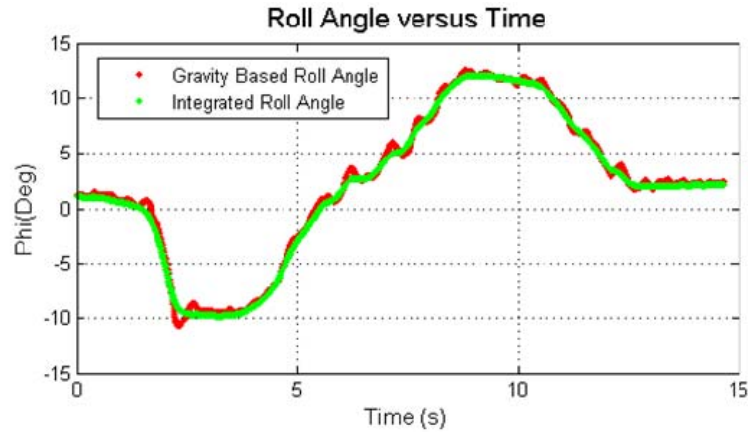

Figure 17. Graph of roll angle against time

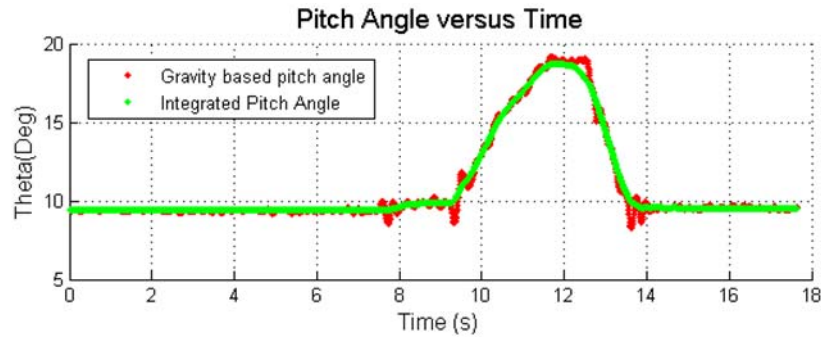

Figure 18. Graph of pitch angle against time

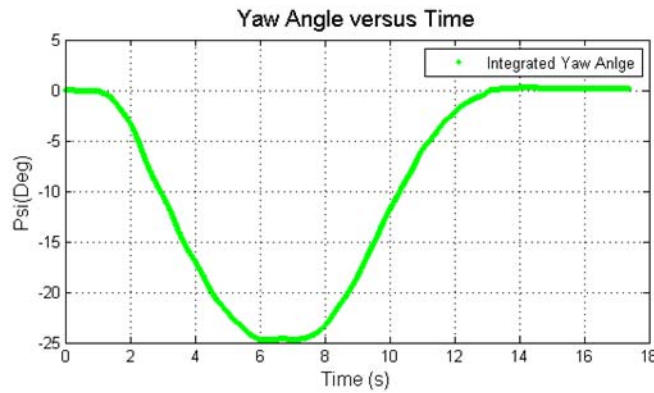

Figure 19. Graph of yaw angle against time

From the above graphs, it can be seen that the gravity based Euler angles and the integrated Euler angles are very close. Thus, it can be concluded that the integrated Euler angles obtained are good enough to be used in the model.



## 2. Target Tracking

The next step is to simulate the ability of the USV to track a target given the geodetic coordinates. For this experiment, the USV and the target is assumed to be located at an arbitrary points at Monterey Bay. Table 4 shows the coordinates of the USV as well as the target vessel. The layout of the scenario is shown in Figure 20.

	Latitude	Longitude	Altitude
Target Vessel	36.6849 <sup>0</sup>	-121.8940 <sup>0</sup>	0 m
SeaFox USV (Start)	36.6757 <sup>0</sup>	-121.9138 <sup>0</sup>	0 m
SeaFox USV (End)	36.6959 <sup>0</sup>	-121.9143 <sup>0</sup>	0 m

Table 4. Geodetic coordinates of USV and target



Figure 20. Scenario layout for target tracking simulation

The USV is assumed to travel due north from its starting position to end up in the ending point as shown in Figure 20. For this simulation, it is assumed that the camera onboard the USV tracks the target under two different conditions, namely without disturbance and with disturbance.

**a. Target Tracking without Disturbance**

In this scenario, the USV moves towards the target without taking into account the disturbances due to the waves on the USV and the camera platform. This is simulated by holding the platform level while the simulation runs. The results of the simulation, showing the plots of pan angle,  $\alpha_{cmd}$  against time and tilt angle,  $\gamma_{cmd}$  against time is shown in Figure 21.

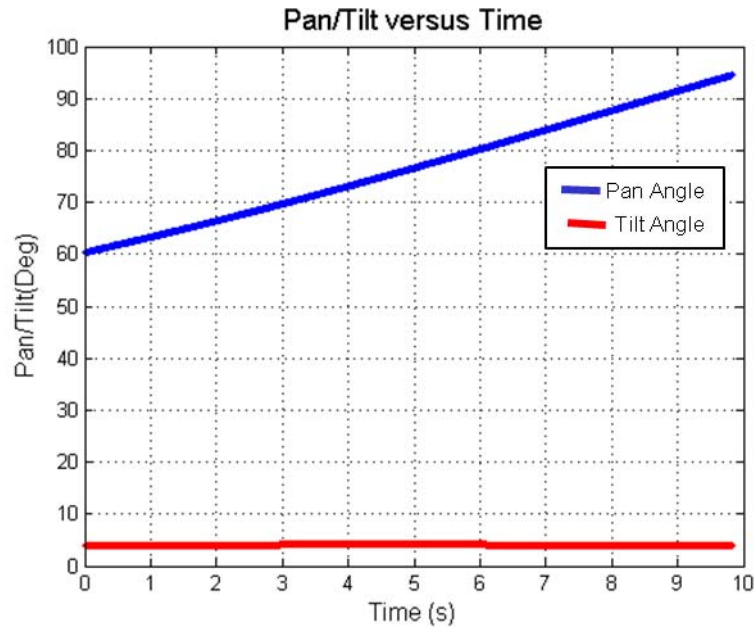

Figure 21. Graph of pan/tilt angles against time for tracking without disturbance

From the graph, it can be seen that the pan angle steadily increases as the USV approaches the target vessel. The tilt angle shows very little change, indicating clearly the unchanged height between the target and the USV.

**b. Target Tracking with Disturbance**

In this scenario, the USV moves towards the target taking into account the disturbances due to the waves on the USV and the camera platform. This is simulated by rotating the platform about each axis so as to simulate roll, pitch and yaw on the USV

during the simulation run. The results of the simulation, showing the plots of pan angle,  $\alpha_{cmd}$  against time and tilt angle,  $\gamma_{cmd}$  against time for each of the disturbances is shown in Figure 22. , Figure 23. and Figure 24.

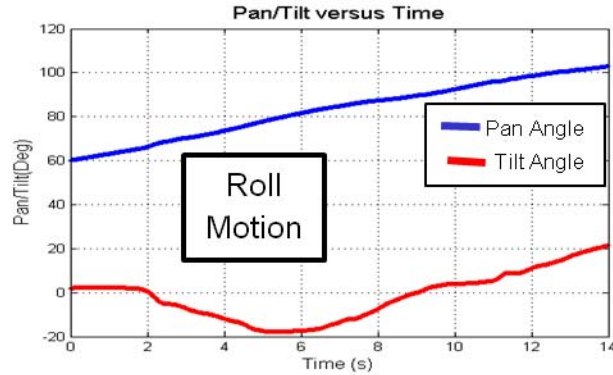

Figure 22. Graph of pan/tilt angles against time for tracking with roll disturbance

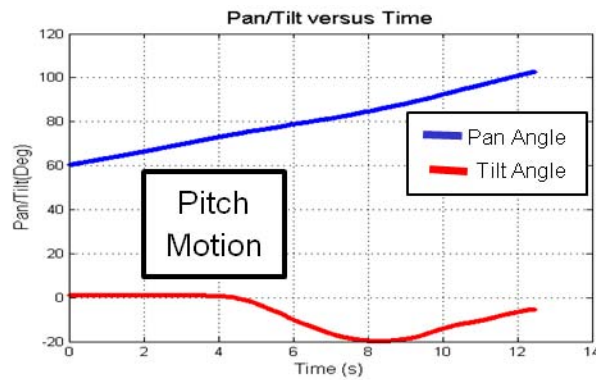

Figure 23. Graph of pan/tilt angles against time for tracking with pitch disturbance

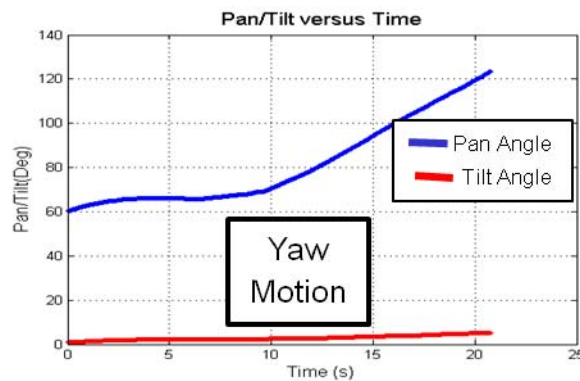

Figure 24. Graph of pan/tilt angles against time for tracking with yaw disturbance

From the graphs above, it can be seen that roll and pitch motions of the USV cause only slight changes to the pan angle. However, in these situations, the tilt angles have more pronounced changes. However, in the third case, where there is yaw motion on the USV, there is substantial changes to the pan angle of the camera while there is only slight change to the tilt angle.

Therefore, based on the results of the simulations, it can be concluded that roll and pitch motion of the USV will cause the tilt angles to vary while the yaw motion of the USV will cause the pan angle to change.

THIS PAGE INTENTIONALLY LEFT BLANK

## **V. CONCLUSIONS AND RECOMMENDATIONS**

### **A. CONCLUSIONS**

A control system for tracking a target vessel using the onboard camera was developed in this thesis. The control system was required to enable the camera to track the target vessel, taking into account the disturbances on the USV and the camera platform caused by the waves. Using the geodetic coordinates of the target, the camera onboard the USV was able to point to and track the target. It was also shown in the simulation that the control system enabled the camera to track the target even with disturbances on the USV.

In order to complete the thesis, hardware in the loop system was implemented by incorporating the EO camera in the system. Using feed forward control, the simulation was re-run and the results showed that the control system behaved in the manner that was required. The control system was able to point the camera and track a single point regardless of the motion of the platform in which it was mounted.

### **B. RECOMMENDATIONS**

The thesis set about to start the phase in incorporating a target tracking system on the Seafox USV. Due to the unavailability of the actual Seafox platform, a Simulink model was built and tested on a bench top experimental set up.

It is recommended that the control system be implemented on the actual Seafox platform. In addition, it is recommended that implementation of PID control be explored so as to enhance the tracking of the target.

The Alticam camera system is also capable of scan which gives the camera additional coverage. It is also recommended that the scan of the camera be implemented in future studies.

THIS PAGE INTENTIONALLY LEFT BLANK

## APPENDIX

### A. IMU PARAMETERS

Parameter	Units	HG1700
Volume	in <sup>3</sup>	33
Weight	lbs	<2
Power	Watts	<8
Non-Operating Shock	g max	<500
Gyro Performance		
Parameter	Units	HG1700
Operating Range	°/sec	± 1074
Scale Factor Repeatability	PPM (1σ)	150
Scale Factor Linearity	PPM (1σ)	150
Bias Repeatability	°/hr (1σ)	1
Bias (In Run Stability)	°/hr (1σ)	1
Bias Static g Sensitivity	°/hr/g (1σ)	
Bias g2 Sensitivity	°/hr/g <sup>2</sup> (1σ)	
Bias Acoustic Rectification Error (ARE)	°/hr max	
Quantization	μ rad max	13.47
Angular Random Walk	deg / hr max	0.125
Axis Alignment Stability	μ rad (1σ)	500
Axis Alignment Stability (nonorthogonality)	μ rad (1σ)	100
Accelerometer Performance		
Parameter	Units	HG1700
Operating Range	g	70
Scale Factor Error	PPM (1σ)	300
Scale Factor Linearity	PPM (1σ)	500
Bias Repeatability	m-g (1σ)	1
Bias Stability	m-g (1σ)	1
Vibration Shift	μ-g Max	500
Axis Alignment Stability (nonorthogonality)	μ rad (1σ)	100
VRW	(m/s) / hr max	0.22



## B. MATLAB FUNCTIONS

### 1. MATLAB function: Alticam\_cmd.m

%%This function converts the incoming pan and tilt command angles, converts them into  
%%the data message, adds the header to the message and sends the final message with  
%%the CRC message to the camera

```
function messageD=alticamTest(u)
u=uint8(u);
header = ['55';'aa';'07';'4d';'01';'00';'00';'98';'00'];%Header message

getData=dec2hex(u); %Gets data from model and converts to hexadecimal
message = [header;getData]; %Combines header message and data message
messageD = uint8(hex2dec(message));
%Computes CRC
CRC = alticamCRC(messageD);
CRChex = dec2hex(CRC);
%Combines CRC to message
message = [message; CRChex(1:2); CRChex(3:4)];
%Output message to camera
messageD = (hex2dec(message));
```

## LIST OF REFERENCES

- [1] S, Kragelund, “NPS After Action Report,” Center for Unmanned Vehicle Systems, Naval Postgraduate School, Monterey, CA, USA, April 2008.
- [2] “Coordinate frame transformations,” class notes for ME4821, Department of Mechanical and Astronautical Engineering, Naval Postgraduate School, Spring 2008.
- [3] B. C. Chang, and C. Jagadish, “Diversified redundancy in the measurement of Euler angles using accelerometers and magnetometers,” in *Proceedings of the 46<sup>th</sup> IEEE Conference on Decision and Control*, New Orleans, LA, USA, 2007.
- [4] R. A, Prince. *Autonomous visual tracking of stationary targets using small unmanned aerial vehicles*. M.S. Thesis, Naval Postgraduate School, Monterey, CA, 2004.
- [5] M. Mercadal, *Alticam User’s Manual*, Hood Technology Corporation, 2006.
- [6] O., Katsuhiko. *Modern control engineering, Fourth Edition*. New Jersey: Prentice Hall, 2002.

THIS PAGE INTENTIONALLY LEFT BLANK

## INITIAL DISTRIBUTION LIST

1. Anthony J. Healey  
Naval Postgraduate School  
Monterey, California
2. Sean Kragelund  
Naval Postgraduate School  
Monterey, California
3. Dudley Knox Library  
Naval Postgraduate School  
Monterey, California
4. Professor Yeo Tat Soon, Director  
Temasek Defence Systems Institute  
National University of Singapore  
Singapore
5. Tan Lai Poh (Ms), Assistant Manager  
Temasek Defence Systems Institute  
National University of Singapore  
Singapore