



Calhoun: The NPS Institutional Archive

Theses and Dissertations

Thesis Collection

2007-06

Modeling insurgency attrition and population influence in irregular warfare

Howell, Jeffrey M.

Monterey, California. Naval Postgraduate School

<http://hdl.handle.net/10945/3418>



Calhoun is a project of the Dudley Knox Library at NPS, furthering the precepts and goals of open government and government transparency. All information contained herein has been approved for release by the NPS Public Affairs Officer.

**Dudley Knox Library / Naval Postgraduate School
411 Dyer Road / 1 University Circle
Monterey, California USA 93943**

<http://www.nps.edu/library>



**NAVAL
POSTGRADUATE
SCHOOL**

MONTEREY, CALIFORNIA

THESIS

**MODELING INSURGENCY ATTRITION AND
POPULATION INFLUENCE IN IRREGULAR WARFARE**

by

Jeffrey M. Howell

June 2007

Thesis Advisor:
Second Reader:

Moshe Kress
Alejandro Hernandez

Approved for public release; distribution is unlimited

THIS PAGE INTENTIONALLY LEFT BLANK

REPORT DOCUMENTATION PAGE			<i>Form Approved OMB No. 0704-0188</i>
Public reporting burden for this collection of information is estimated to average 1 hour per response, including the time for reviewing instruction, searching existing data sources, gathering and maintaining the data needed, and completing and reviewing the collection of information. Send comments regarding this burden estimate or any other aspect of this collection of information, including suggestions for reducing this burden, to Washington headquarters Services, Directorate for Information Operations and Reports, 1215 Jefferson Davis Highway, Suite 1204, Arlington, VA 22202-4302, and to the Office of Management and Budget, Paperwork Reduction Project (0704-0188) Washington DC 20503.			
1. AGENCY USE ONLY (Leave blank)	2. REPORT DATE June 2007	3. REPORT TYPE AND DATES COVERED Master's Thesis	
4. TITLE AND SUBTITLE Modeling Insurgency Attrition and Population Influence in Irregular Warfare		5. FUNDING NUMBERS	
6. AUTHOR(S) Jeffrey Howell		8. PERFORMING ORGANIZATION REPORT NUMBER	
7. PERFORMING ORGANIZATION NAME(S) AND ADDRESS(ES) Naval Postgraduate School Monterey, CA 93943-5000		10. SPONSORING/MONITORING AGENCY REPORT NUMBER	
9. SPONSORING /MONITORING AGENCY NAME(S) AND ADDRESS(ES) N/A		11. SUPPLEMENTARY NOTES The views expressed in this thesis are those of the author and do not reflect the official policy or position of the Department of Defense or the U.S. Government.	
12a. DISTRIBUTION / AVAILABILITY STATEMENT Approved for public release; distribution is unlimited		12b. DISTRIBUTION CODE	
13. ABSTRACT (maximum 200 words) We develop a model that is a combination of Lanchester and Deitchman attrition models and population epidemic models. Based on different attrition, recruitment, and transition rules we study the relationships between dynamic population flow and insurgency success or failure. The goal of our work is to provide an analytical framework for these situations and to analyze the effect of different initial conditions and interactions on the success or failure of an insurgency. The models developed herein are descriptive, not predictive, and are designed to give decision makers an insight into a complex insurgency process.			
14. SUBJECT TERMS Irregular Warfare, Difference Equations, Epidemiology Models		15. NUMBER OF PAGES 77	
		16. PRICE CODE	
17. SECURITY CLASSIFICATION OF REPORT Unclassified	18. SECURITY CLASSIFICATION OF THIS PAGE Unclassified	19. SECURITY CLASSIFICATION OF ABSTRACT Unclassified	20. LIMITATION OF ABSTRACT UL

NSN 7540-01-280-5500

Standard Form 298 (Rev. 2-89)
Prescribed by ANSI Std. Z39-18

THIS PAGE INTENTIONALLY LEFT BLANK

Approved for public release; distribution is unlimited

**MODELING INSURGENCY ATTRITION AND POPULATION INFLUENCE IN
IRREGULAR WARFARE**

Jeffrey M. Howell
Major, United States Army
B.S., University of Nevada, 1995

Submitted in partial fulfillment of the
requirements for the degree of

MASTER OF SCIENCE IN OPERATIONS RESEARCH

from the

**NAVAL POSTGRADUATE SCHOOL
June 2007**

Author: Jeffrey M. Howell

Approved by: Moshe Kress
Thesis Advisor

Alejandro Hernandez
Second Reader

James N. Eagle, Ph.D.
Chairman, Department of Operations Research

THIS PAGE INTENTIONALLY LEFT BLANK

ABSTRACT

We develop a model that is a combination of Lanchester and Deitchman attrition models and population epidemic models. Based on different attrition, recruitment, and transition rules, we study the relationships between dynamic population flow and insurgency success or failure. The goal of our work is to provide an analytical framework for these situations, and to analyze the effect of different initial conditions and interactions on the success or failure of an insurgency. The models developed herein are descriptive, not predictive, and are designed to give decision makers an insight into a complex insurgency process.

THIS PAGE INTENTIONALLY LEFT BLANK

TABLE OF CONTENTS

I.	INTRODUCTION.....	1
II.	BACKGROUND AND LITERATURE REVIEW	3
	A. GUERRILLA WARFARE.....	3
	B. MODELING GUERRILLA WARFARE	5
	C. POPULATION DYNAMICS MODELING	8
	D. CURRENT EFFORTS	10
III.	INSURGENCY ATTRITION MODEL WITH DYNAMIC POPULATION SUPPORT	13
	A. OVERVIEW	13
	B. ATTRITION DYNAMICS.....	16
	C. POPULATION DYNAMICS.....	21
	D. COMPLETE MODEL:	24
IV.	ANALYSIS	25
	A. PURPOSE AND METHODOLOGY	25
	1. Analysis of OIF Data	25
	2. Initial Parameters and Time Resolution.....	27
	3. Basic Model Setup.....	30
	4. Advanced Model Setup.....	31
	B. BASIC MODEL	31
	C. ADVANCED MODEL.....	39
	D. FINAL NOTES.....	49
V.	CONCLUSIONS	51
	A. RESULTS	51
	B. FUTURE RESEARCH.....	52
	APPENDIX A. OPERATION IRAQI FREEDOM DATA	53
	LIST OF REFERENCES.....	57
	INITIAL DISTRIBUTION LIST	59

THIS PAGE INTENTIONALLY LEFT BLANK

LIST OF FIGURES

Figure 1.	Flow Chart of Castillo-Chavez & Song Model (2004).....	10
Figure 2.	Flow Chart of Population Model	14
Figure 3.	Intelligence Functions.....	18
Figure 4.	Population Division in Base Run (60 months): Basic Model.....	32
Figure 5.	Insurgency Strength in Base Run (60 months): Basic Model.....	32
Figure 6.	Population Division in Base Run (120 months): Basic Model.....	33
Figure 7.	Insurgency Strength in Base Run (120 months): Basic Model.....	33
Figure 8.	Insurgency and Contrarian Interaction over Time	34
Figure 9.	Concave, Linear and Convex Intelligence Functions for $\beta = 5$	35
Figure 10.	Concave, Linear and Convex Intelligence Functions for $\beta = 0.5$	36
Figure 11.	Intelligence Functions Effect On $I(t)$ in Base Model ($\beta = 5$).....	37
Figure 12.	Base Model $I(t)$ with $\rho_{SC} = A_I + A_{PI} - A_G - A_{PG}$ (60 months).....	38
Figure 13.	Base Model $I(t)$ with $\rho_{SC} = A_I + A_{PI} - A_G - A_{PG}$ (120 months).....	38
Figure 14.	Base Model Population Division with $\rho_{SC} = A_I + A_{PI} - A_G - A_{PG}$	39
Figure 15.	Population Division in Base Run of Advanced Model.....	41
Figure 16.	Insurgency Strength in Base Run of Advanced Model.....	41
Figure 17.	Population Division in Base Run of Advanced Model.....	42
Figure 18.	Insurgency Strength in Base Run of Advanced Model.....	42
Figure 19.	Insurgency and Contrarian Interaction over Time, Advanced Model	43
Figure 20.	Intelligence Functions Effect On $I(t)$ in Advanced Model	44
Figure 21.	Advanced Model $I(t)$ with $\rho_{SC} = A_I + A_{PI} - A_G - A_{PG}$ for 60 months	44
Figure 22.	Advanced Model $I(t)$ with $\rho_{SC} = A_I + A_{PI} - A_G - A_{PG}$ for 120 months	45
Figure 23.	Advanced Model Population Division with $\rho_{SC} = A_I + A_{PI} - A_G - A_{PG}$	46
Figure 24.	Recruitment Functions Effect On $I(t)$ in Advanced Model	47
Figure 25.	Government γ Functions Effect On $I(t)$ in Advanced Model.....	48

THIS PAGE INTENTIONALLY LEFT BLANK

LIST OF TABLES

Table 1. Initial Functions and Values for the Basic Model31
Table 2. Initial Functions and Values for the Advanced Model40

THIS PAGE INTENTIONALLY LEFT BLANK

ACKNOWLEDGMENTS

First and foremost, I would like to thank my Advisors, Dr. Moshe Kress and Colonel Alejandro Hernandez for their guidance, constant encouragement and willingness to take on a somewhat unconventional project. I would like to thank the Special Operations Command for the accessibility and guidance on the current direction of analytical analysis of irregular warfare.

I would like to thank my family for their support and encouragement in this endeavor.

THIS PAGE INTENTIONALLY LEFT BLANK

EXECUTIVE SUMMARY

Irregular warfare is not a new form of warfare. Weaker forces have always utilized irregular tactics to attack a more powerful foe. United States conventional military superiority forces our foes to adopt these irregular tactics to have any reasonable chance of success. Current conventional military models and tools are ill-suited for analytical analysis of this type of warfare. The human element and the importance of population support are magnified in these types of conflicts and new tools must be developed.

Our tools are attrition and population epidemic models originally developed for conventional warfare and for the study of the spread of infectious diseases. Our fundamental premise is that a combination of these two types of models can yield important insights into the key relationships between an insurgency and the contested population.

We consider two models: a base model with constant parameters, and more advanced model with opportunistic and idealistic recruitment, various levels of government effort against the insurgency and different ways of modeling population support. We find, much like the real world, that initial conditions and policy decisions have a strong impact on the outcome of the conflict. Opposing factions that tailor their tactics to the situation (a government focusing on securing the population in a security minded public) have a much greater chance of success. We also demonstrate the importance of good intelligence.

THIS PAGE INTENTIONALLY LEFT BLANK

I. INTRODUCTION

Traditional wargames and models that apply to conventional warfare do not fare well when applied to asymmetric conflicts such as insurgency and guerrilla warfare. Legacy force-on-force models that capture attrition, detection, and movement have less utility in measuring intangible affects, which include population behavior, civil-military operations, and psychological operations - all central aspects in insurgency and counter-insurgency situations. The human component of this type of conflict makes analysis extremely difficult, but not impossible.

One of the more important aspects of low intensity conflicts, guerrilla warfare, and insurgencies is population control and population influence. These types of conflicts center on the effort to win the support of the population. An insurgency cannot exist without some degree of population support. If we divide the total population into distinct groups of supporters and contrarians, it should be possible to model the transfer and movement of individuals among these population subclasses and analyze the overall effect their support has on the contending factions. We simplify movement between these subclasses and model them for analysis. Being in a particular supporting population subclass does not particularly mean organized membership in the insurgency or government, but rather represents willing or coerced support of that particular organization. Individuals move from subclass to subclass based on the actions and non-actions of the insurgency and the government. These activities include non-violent actions: civil affairs, psychological operations, and propaganda; and more violent and direct action such as coercion, combat, terrorist acts, criminal activities, and collateral damage. Some activities are more difficult to quantify than others, especially the activities directly related to human behavior.

Population influence models have already been developed from dynamic population models and epidemiological models to study information flow through populations. Warfare attrition models have been in development and use for nearly 100 years. This thesis examines the utility of combining dynamic population influence models

and conventional deterministic attrition models to develop a new Irregular Warfare model to analyze the relationship between irregular warfare and population influence and control.

If conventional warfare is a complex situation that is difficult to model in the best of circumstances, then unconventional warfare is a nightmare for analytical analysis. Irregular strategies rely heavily on deception and deceit. Many aspects of this type of warfare (recruitment, desertion, psychological warfare, etc.) are based on individual human behavior and are very difficult to model. The primary goal of this thesis is to provide a descriptive tool to help understand cause-and-effect relations in the context of insurgency warfare directly related to population support and control.

Chapter II provides a short explanation of irregular and guerrilla warfare, a review of conventional and unconventional combat attrition models, an examination of epidemiological models as applied to quantitative modeling of population dynamics, and an investigation of current efforts by the United States Department of Defense (DOD) and other civilian agencies to analytically study the phenomenon of irregular warfare. Chapter III develops and explains our irregular warfare and population model including explanations of notation, terminology, and model assumptions. Chapter IV analyses our model and explores its behavior based on reasonable real world initial conditions based on data gathered on the current asymmetric conflict in Iraq. Chapter V presents our conclusion and recommends future research in the field.

II. BACKGROUND AND LITERATURE REVIEW

The guerrilla must move amongst the people as a fish swims in the sea.

— Mao Tse Tung

A. GUERRILLA WARFARE

Irregular and asymmetric warfare have always been the strategies of choice for mismatched combatants: the ‘weak’ against the ‘strong’. Insurgency has probably been the most prevalent type of armed conflict since the creation of organized political communities. This type of conflict has experienced a major resurgence: between 1969 and 1985 the number of major international terrorist incidents alone jumped from just under two hundred to over eight hundred per year. (O’Neill, 2005) In this historically important mode of conflict, the United States has an almost unbroken string of frustration (and disappointment) that can be traced backward nearly half a century from the situation in Iraq today to the early 1960s when the United States became heavily engaged in Indochina’s wars. (Hoffman, 2004)

Terms like insurgency, guerrilla warfare, and terrorism have been defined in various ways and used interchangeably throughout the years. For a common basis, we define insurgency as “a struggle between a non-ruling group and the ruling authorities in which the nonruling group consciously uses political resources (e.g. organizational expertise, propaganda, and demonstrations) and violence to destroy, reformulate, or sustain the basis of legitimacy of one or more aspects of politics.” (O’Neill, 2005) Guerrilla warfare and terrorism can be defined as violent tactics of insurgent conflicts. These tactics primarily include avoiding direct confrontation and carefully choosing battles to maximize local force superiority. As in any conflict, the side most able to maximize its strengths and minimize its weaknesses is most likely to emerge victorious. Most insurgencies would seem to face overwhelming weaknesses and insurmountable odds when the conventional measuring sticks of strengths and weaknesses are applied. A closer examination reveals the inherent strengths of this type of warfare that have

bedeviled conventional militaries since the dawn of warfare. Insurgency leaders know that they risk destruction by confronting government forces in direct conventional engagements so they opt to erode the strength of the government through the use of terrorism or guerrilla warfare, not only to increase the human and material cost to the government but also to demonstrate its failure to maintain effective control and provide protection for the people. (O'Neill, 2005)

An irregular approach to warfare more keenly focuses on war as an extension of politics and is fought immediately among the people. In fact, the terrain of this battlefield can be thought of as the population the government and the insurgency are fighting to influence and control; a zero-sum conflict over the same political-space. (McCormick and Giordano, 2002) Evidence amassed on guerrilla battlefields over the last three decades indicates that civilian support is the essential element of successful guerrilla operations. (O'Neill, 2005)

Insurgency strategies can be broken down into four broad strategic approaches: conspiratorial, protracted popular war, military focus, and urban warfare. The conspiratorial strategy seeks to remove the ruling authorities through a limited but swift use of force. (O'Neill, 2005) This strategy favors quick decisive action and external support is generally not a major consideration. Another strategy that relies heavily on a small armed group with little external support is the military focus strategy, or guerrilla "foco," developed by Fidel Castro and Che Guevara in the 1960's. (O'Neill, 2005) This strategy relies on a small guerrilla focus, or foco, to take up arms and become the nucleus of a popular army. Needless to say, a weak government seems to be a necessity for the success of the foco strategy. It is debatable if Castro would have had as much success had he not faced the profoundly divided and weak Batista government. Che Guevara's spectacular failure in Bolivia only illustrates that any reasonably strong government would take resolute steps to eradicate any insurgency that threatens their political system. (O'Neill, 2005)

The third primary insurgency strategy, and the strategy we are most interested in examining is the strategy of protracted popular war. This strategy is conceptually the most elaborate and, perhaps, the most widely copied strategy. (O'Neill, 2005) Although

this strategy has existed for thousands of years, Mao is considered the primary architect of this strategy for his successful Chinese Communist victory. Mao offered insurgents around the world a cohesive, systematic blueprint for their own struggles against colonial occupiers or oppressive indigenous regimes. (O’Neill, 2005) We are most interested in the protracted popular war effort because insurgencies utilizing this strategy must gain and maintain extensive popular support to have any chance for ultimate victory. There is a mathematical linkage between attrition in insurgency warfare and population dynamics modeling, which allows researchers to examine this aspect of the strategy analytically.

B. MODELING GUERRILLA WARFARE

Frederick Lanchester developed his attrition equations for military conflict in 1916. The original Lanchester equations treated two types of combat. In the Linear Law,

$$\begin{aligned}\frac{dx}{dt} &= -Axy \\ \frac{dy}{dt} &= -Byx\end{aligned}\tag{1}$$

the attrition is proportional to an attrition coefficient and the size of both forces. This model is usually associated with area fire: indirect artillery weapons or fire into an area where an unseen enemy is located (like an ambushing guerrilla force). With aimed fire (the Lanchester Square Law),

$$\begin{aligned}\frac{dx}{dt} &= -Ay \\ \frac{dy}{dt} &= -Bx\end{aligned}\tag{2}$$

the attrition of one side is proportional only to the opponent’s size and its effectiveness (attrition coefficients A or B). The square law and the linear law are so named because they reveal a powerful insight about area versus direct fire weapons. In the linear law, assuming equal effectiveness between forces, the winner is determined only by the larger force size: if $\frac{x_0}{y_0} > \frac{A}{B}$ then the x forces will win the battle, however, if $\frac{x_0}{y_0} < \frac{A}{B}$ then the y forces win. In the square law, however, the square of the size of the forces is proportional

to the attrition coefficients ratio at parity: $\frac{x_0^2}{y_0^2} = \frac{A}{B}$ is a fight to the death and an increase

in the attrition coefficient in the square model can be overcome by a small increase in the size of the relative forces. In both of these models the battle is characterized by the initial force levels and the attrition coefficients. In the square law model (or modern combat model) the fighting strength of a force can be represented by the square of its numerical strength. Lanchester originally proposed these combat models to argue the benefits of force concentration in modern warfare and especially in the burgeoning area of air combat. Further analysis led to other interesting applications of these equations.

In “A Lanchester Model of Guerrilla Warfare,” S.J. Deitchman (1962) incorporated both the linear and square laws in an early attempt to mathematically model guerrilla warfare.

$$\begin{aligned}x &= -Axy \\ y &= -Bx\end{aligned}\tag{3}$$

If the guerrilla can take advantage of its informational advantage it can choose its conflicts wisely leading to local force superiority and the utilization of ambush tactics. In this type of battle, ambushed conventional forces are unable to target the guerrillas and must fire blindly into the area the guerrillas occupy. Guerrilla losses are proportional to the number of ambushed forces firing and the number of guerrillas occupying the area. (Deitchman, 1962) The guerrillas are able to fire at the conventional forces in full view and hence conventional losses are only proportional to the number of guerrillas firing. This leads to a linear law (1) of attrition for the guerrilla side, and a square law of attrition for the government side (2). The conditions for parity have now changed.

$$\frac{x_0}{y_0^2} = \frac{A}{2B}\tag{4}$$

A key difference from the original Lanchester equations is that the attrition coefficients (A and B) in this case can differ by orders of magnitude. Area fire has reduced the effectiveness of conventional troops by possibly 10-100 times because the probability of unaimed fire hitting a small ambushing force is much smaller than the probability of aimed fire hitting fully exposed troops. These equations also do not take

into account the element of surprise that an ambushing force possesses. Ambush tactics are not the sole providence of the guerrillas. If the government forces can turn the situation around and attack the guerrillas using small groups, ambush tactics, and local numerical superiority then the guerrillas' chances of winning become very small indeed. (Deitchman, 1962) Ambush tactics are heavily reliant on intelligence which is a key element of an effective insurgency.

In "The Dynamics of Insurgency," Gordon McCormick and Frank Giordano (2002) expand this analysis of guerrilla warfare by adding the effects of popular opinion, recruitment, and intelligence to the differential equations.

$$\begin{aligned}\frac{dx}{dt} &= a\left(1 - \frac{x}{k_x}\right)x - m'xy \\ \frac{dy}{dt} &= b\left(1 - \frac{y}{k_y}\right)y - n'x\end{aligned}\tag{5}$$

Deitchman had already recognized the linear and square law relationships of attrition between the guerrilla and government forces; McCormick and Giordano took the analysis a step further and attempted to quantify the ability of these combatants to recruit and mobilize forces from a core constituency and measure the state's and insurgency's ability to 'see' each other during the conflict. The contested political population is divided into three categories of people at any time: potential government supporters, potential insurgency supporters and the undecided. (McCormick & Giordano, 2002) Given a starting "popular will," growth intensities (the recruitment and growth rates for the insurgency and government respectively), and combat effectiveness parameters for units, we can now model both the attrition of forces based on irregular warfare tactics and strategy, and the mobilization and recruitment of forces based on popular will. One more significant factor needs to be incorporated: information. The insurgency begins with an ability to see their opponents, but a very limited ability to attack what they see. The state faces the opposite dilemma: a much greater ability to attack what it does see, but a limited ability to see what it wishes to attack. (McCormick & Giordano, 2002) McCormick and Giordano modify the effectiveness parameters of each side based on their information advantage or disadvantage. Information, in their model, is a

conditioning variable that, for any given force balance, can improve or degrade each side's capacity to target the other. (McCormick & Giordano, 2002) Essentially, McCormick and Giordano expanded Deitchman's area and linear equations for guerrilla conflict and introduced growth (a and b) and support (k_x and k_y) parameters for recruitment and mobilization. By attempting to quantify, at a basic level, the political and informational efforts of government and insurgent forces, McCormick and Giordano had taken a major step in modeling the soft combat efforts of information warfare, recruiting, and humanitarian efforts that are of enhanced importance in insurgencies.

C. POPULATION DYNAMICS MODELING

Mathematical modeling of epidemiological phenomenon has been developed and studied since the beginning of the 20th century. At its core, mathematical epidemiological modeling can be utilized to map disease progression through a human population. This is accomplished by dividing the population into subclasses that reflect the epidemiological status of individuals who in turn transit between classes via mutual contact at given average rates. (Bettencourt, Cintron-Arias, Kaiser, & Castillo-Chavez, 2006) More advanced models can be used to identify the role of specific population characteristics such as age, variable infectivity, and variable infectious periods. (Bettencourt et al., 2006)

Studies have shown the quantitative similarities between the spread of ideas and dynamic fanatic behaviors through a population and the dynamics of the spread of infectious diseases. These similarities have been developed and studied as early as 1953. Instead of dividing populations into epidemiological subclasses, these models are more interested in social states: ignorants, spreaders, and stiflers. Bettencourt, et al draw parallels between epidemics and idea diffusion in their paper "The Power of a Good Idea: Quantitative Modeling for the Spread of Ideas from Epidemiological Models," while Carlos Castillo-Chavez and Baojun Song take the modeling in a new direction with "Models for the Transmission Dynamics of Fanatic Behaviors." By dividing an entire population into non-core, susceptible, semi-fanatic, and fanatic sub-populations, and developing mathematical interactions, Castillo-Chavez and Song attempts to model the recruitment and conversion of one sub-population entity to another sub-population.

$$\begin{aligned}
\frac{dG}{dt} &= \Lambda - \beta_1 G \frac{C}{T} + \gamma_1 E + \gamma_3 F - \mu G \\
\frac{dS}{dt} &= \beta_1 G \frac{C}{T} - \beta_2 S \frac{E+F}{C} - \gamma_1 S - \mu S \\
\frac{dE}{dt} &= \beta_2 S \frac{E+F}{C} + \beta_3 E \frac{F}{C} - \mu E \\
\frac{dF}{dt} &= \beta_3 E \frac{F}{C} - \gamma_3 F - \mu F
\end{aligned} \tag{6}$$

In this mode, G is the non-core population, S is the susceptible portion, and E and F are the semi-fanatic and fanatic parts. The ‘core’ population, the susceptible, semi-fanatic and fanatic subpopulations recruit from the non-core general population through “contacts” between core and non-core individuals. (Castillo-Chavez & Song, 2004)

Figure 1 is a graphical representation of the flow of individuals through the different sub-population. β_i measures the strength of the recruitment and γ_i denotes the per-capita recovery rate for each subpopulation in the core, hence, $\frac{1}{\gamma_i}$ is the average residence time for each subpopulation in the core. (Castillo-Chavez & Song, 2004)

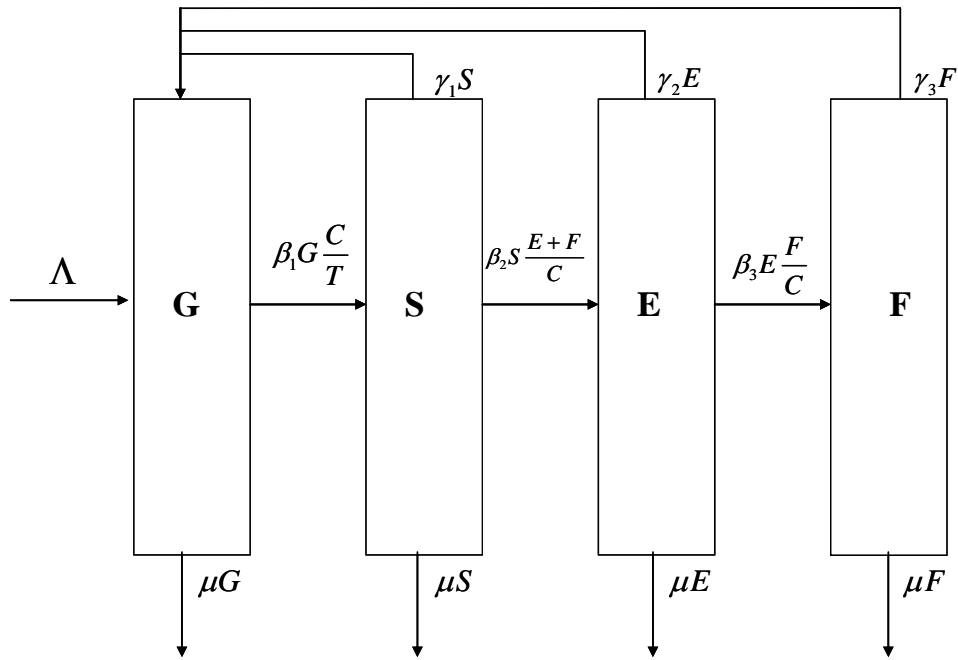

Figure 1. Flow Chart of Castillo-Chavez & Song Model (2004)

This type of model does not describe a strictly evolutionary process because individuals can visit different states more than once, unlike many epidemiological models where individuals are often immune to a disease after they are vaccinated or survive the disease. By modeling the transfer of individuals between possibly contrarian subpopulations, Castillo-Chavez and Song have taken a step in creating a dynamic population model that represents a core constituency for opposing political and military forces.

D. CURRENT EFFORTS

Harrison C. Schramm expanded on these models and developed deterministic and stochastic models for the flow of diametrically opposed ideas. These ideas are actively supported or opposed by individuals who actively vie for a greater share of support from the public. An interesting result of his efforts is that it takes a relatively small number of contrarians to overcome a large increase in the supporter of an idea. (Schramm, 2006) Other analytical efforts include social and organizational network modeling to identify

and destroy insurgencies and terrorist organizations (Hammes, 2006), and agent based modeling and simulation consisting of discrete heterogeneous sets of individual agents each with its own characteristic properties and rules of behavior. Agent based modeling (ABM) is an increasingly popular tool to explore artificial life and the basic idea that complicated global behavior of a system derives from low level interaction of its constituent agents. Insights about real-world systems are hoped to be gained by ABM, but modeling large systems with vast numbers of agents, characteristics, and rules become prohibitively difficult in computing time and power.

THIS PAGE INTENTIONALLY LEFT BLANK

III. INSURGENCY ATTRITION MODEL WITH DYNAMIC POPULATION SUPPORT

All models are wrong, some are useful.

— George Box

A. OVERVIEW

The basis for the insurgency attrition model presented in this thesis is a combination of Lanchester and Deitchman difference-equation attrition models with epidemiological population models for the transfer of individuals from population subclasses to other population subclasses. Recall the base guerrilla warfare equations from the McCormick and Giordano model.

$$\begin{aligned}\frac{dx}{dt} &= a\left(1 - \frac{x}{k_x}\right)x - m'xy \\ \frac{dy}{dt} &= b\left(1 - \frac{y}{k_y}\right)y - n'x\end{aligned}\tag{7}$$

The attrition to the government forces y follows Lanchester's square law and the attrition to the insurgency x follows Lanchester's linear law. Our model will incorporate this area vs. direct fire concept but with a focus on attrition caused to the insurgency. The growth and support parameters for the insurgency (b and k_y) in the McCormick model are replaced by a population transition model based on epidemiological models similar to those developed by Castillo-Chavez and Song (Figure 1) except we have simplified the population dynamics by creating only two subpopulations and one population transition parameter. This simpler model (Figure 2) allows basic analysis of population transition based on a transition parameter ρ_{SC} and the interaction between the supporter $S(t)$ and contrarian $C(t)$ populations. Individuals can also be recruited out of the contrarian population to increase the strength of the insurgency $I(t)$.

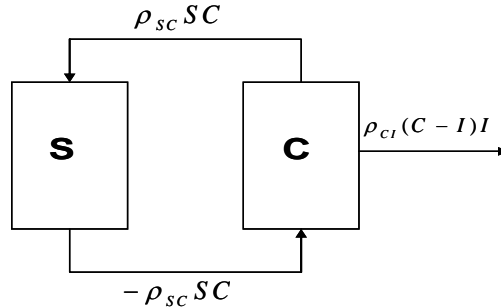

Figure 2. Flow Chart of Population Model

Unlike the McCormick and Giordano model, our model has no recruitment or physical attrition to the government forces, but rather degradation in the government’s ability and will to fight the insurgency. In a protracted popular war the insurgency is initially too weak to affect the government forces in terms of men and material. The insurgency’s initial goal is to grow themselves to a force level large enough enter the conventional phase of the conflict and challenge the government forces. Until they reach the conventional phase, attrition against the government is a useful tool to gain recruitment, increase insurgent morale, and stay relevant. Government strength in this model is represented only by the “effort” they expend against the insurgency, the intelligence they gather, and the support from the friendly portion of the population. Since the insurgency cannot attrite the government forces to any appreciable degree the government’s strength level is constant and is only a scaling factor that can be eliminated from the final model.

The standard notation and definitions we will utilize for the irregular warfare model follows:

Attrition parameters:

A_{PI} : attrition to the population caused by the insurgency.

A_{PG} : attrition to the population caused by the government.

A_P : total attrition to the population ($A_{PI} + A_{PG}$).

A_G : attrition to the government caused by the insurgency.

A_I : attrition to the insurgency caused by the government.

Policy parameters:

γ : government attrition coefficient against the insurgency.

α_G : insurgency attrition coefficient against the government.

α_P : insurgency attrition coefficient against the population.

Intelligence and population parameters:

μ : intelligence level of the government about the insurgency.

ρ_{SC} : rate at which individuals change from Supporters to Contrarians or vice versa.

ρ_{CI} : measures the recruitment rate for the insurgency.

Population and Insurgency:

$I(t)$: size of the insurgency at time t .

$S(t)$: measures the portion of the population that supports the government at time t .

$C(t)$: measures the portion of the population that supports the insurgency at time t .

$S(t) + C(t)$ is the total contested political population. All of the parameters in the model are scaled by the total contested population so $S(t) + C(t) = 1$. The insurgency, $I(t) \leq C(t)$, is also represented by a number between 0 and 1. $I(t)$ does not represent a direct proportion of the total population. It is a fraction of the contrarian population and a measure of the strength of the insurgency's numbers and influence over time. In a real insurgency when the insurgency reaches a certain level of strength it will either displace the government and seize power or possibly enter into a protracted conventional conflict. Our focus is in examining the parameters and processes that influence an insurgency's rise or decline.

In this model an important assumption is that transfer of information among the insurgency, government, and population is immediate and truthful, i.e. collateral damage to the population caused by the government is immediately recognized by the population as violence caused by the government; it cannot be blamed on the insurgency and vice versa. This assumption ignores the ability of contending factions to incorporate some aspects of misinformation in their strategies.

The overall model can be broken down into two main sections: attrition dynamics and population dynamics.

B. ATTRITION DYNAMICS

In our model, we are interested in examining the effects of attrition to the insurgency through different government policies and actions. The goal of a counter-insurgency campaign is to attrite the insurgency to a point of irrelevance. This can be anywhere from complete annihilation to some level of tolerable insurgency size and activity. Due to their advantages in size (personnel and equipment), training and firepower, a reasonably established government military force has the capability to eradicate an opposing guerrilla force if that guerrilla force is fully exposed. Whether government forces have the political will and/or information advantage necessary to bring their conventional combat advantages to bear in an unconventional conflict of this type is another matter. The guerrilla forces have a much more challenging mission: defeat a more powerful and more established state. They are unlikely to have the relative “knockout” ability the government possesses. Their actions to attrite the government are based on eroding the political will and popular support of the government.

Attrition to the government is represented in the model, but the insurgency does not “win” by defeating the powers that be. The insurgency wins by not losing: by consuming the states political space and replacing the government itself. Initially insurgency operations against the government have very little effect on the total strength of the government forces, but they can have a large impact on the perceptions of the population and the morale of the insurgents. In this model, government forces do not suffer physical attrition. Attrition caused to the government by the insurgency has other affects: increased insurgency recruitment, increased contrarian support and possibly increased government efforts against the insurgency. The insurgency can also try to show the incompetence of the government forces by publicly defeating them and/or attempting to gain control of a geographic or geopolitical area for a period of time. The insurgency attrition coefficient against the government α_G is multiplied by the size of the insurgency, $I(t)$.

$$A_G = \alpha_G I(t) \quad (8)$$

In general, the insurgency conducts three primary forms of organized violence: terrorism, guerrilla warfare, and conventional warfare. (O'Neill, 2005) The first two are the tactics of the weak against the strong utilized to harass and gradually erode the will and capability of the state. The insurgency attrition coefficient α_G is a reflection of the tactics utilized by the insurgency. Once an insurgency has matched the size and strength of the government forces they can move into the conventional combat phase of irregular warfare and more directly affect the military forces of the government. In that case, other combat models are more applicable.

In order to examine the attrition to the insurgency and the attrition to the population it is necessary to examine the impact of government intelligence. The only real advantage that most insurgencies possess over their more conventional government foes is in the area of information. The ability of the insurgency to choose when and where to fight can overcome their force deficiencies. To overcome this information advantage, government forces must maximize their counter-insurgency (COIN) intelligence and counter-intelligence efforts. Many intelligence gathering activities are directly related to the amount of active population support for the government. In our model, the level of intelligence for government forces μ is between 0 (no intelligence) and 1 (perfect intelligence) and is directly related to the amount of government supporters in the total population. The return on this population support in regards to the intelligence efforts against the insurgency can be modeled by a variety of functions. Figure 3 represents four functions that could represent different intelligence levels as a function of the population support, represented by $S(t)$.

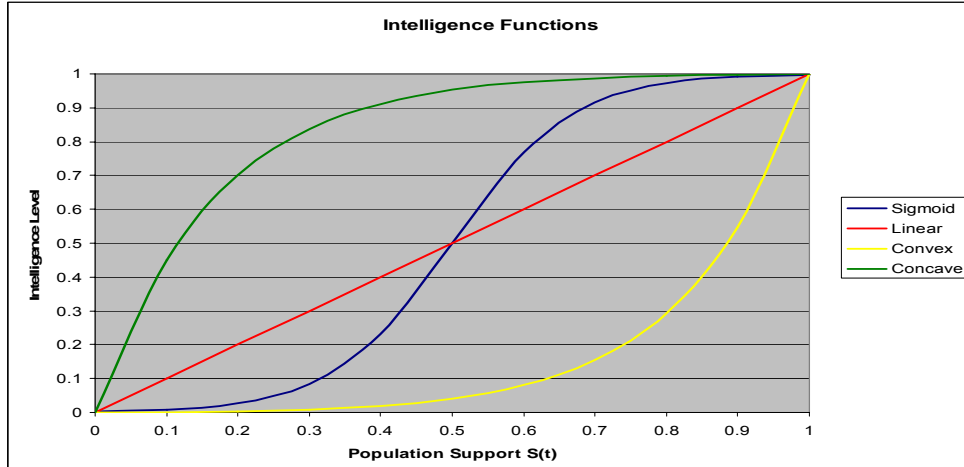

Figure 3. Intelligence Functions

A convex function requires significant population support for the government to have a reasonable intelligence level about the insurgency, while a concave function is just the opposite: minimal government support provides significant intelligence dividends. The sigmoid function provides for steep increases and declines around a median point (in this case 0.5 government support). The simplest function is a linear relationship between the support of the population for the government and the intelligence level against the insurgency.

Now we can examine the other three types of attrition in the insurgency model: attrition to the insurgency, attrition to the population caused by the insurgency and attrition to the population caused by the government.

The government attrition coefficient against the insurgency is represented by γ which takes into account a number of government capabilities, activities and policy decisions. One common government policy is to conduct counter-insurgency activities when either the government forces or the population are attacked by an insurgency. Other possible policies include ignoring attacks against the population and/or attacking a political entity when it is first detected regardless of its offensive nature. The former would seem to be a losing proposition in the long run as the population would quickly lose confidence in the government's ability to provide security. The latter is a policy that police states undertake to eliminate political movements. Attrition caused to the

population in the form of collateral damage by the government could be a factor that dampens the overall effort and effectiveness of the government's operations. In general, we describe this parameter as monotonically increasing in A_G and A_{PI} and monotonically decreasing in A_{PG} .

$$\gamma = A_G + A_{PI} - A_{PG} \quad (9)$$

A more complex relationship could emphasize a stronger reaction to attacks on government forces,

$$\gamma = 2A_G + A_{PI} - A_{PG} \quad (10)$$

or a multiplicative relationship.

$$\gamma = \frac{A_G A_{PI}}{A_{PG}} \quad (11)$$

We discuss government policies and dynamics that can represent these equations in Chapter IV.

Attrition to the insurgency is the primary effort of the government forces; the objectives are to find, fix, and destroy the insurgency. This attrition against the insurgency is affected by three main factors: the government's offensive counter-insurgency effort, γ , the government's intelligence level, μ , and the size of the insurgency, $I(t)$. The overall COIN effort, γ , can represent straightforward offensive effort against any threats to the regime, or a more complicated set of policy decisions based on insurgency activities, size, and intelligence factors, such as the ability to quickly and accurately process intelligence and provide the information to the operators in the field. This effort factor is multiplied by the intelligence factor μ and the complement of the intelligence factor, $(1 - \mu)$, times the size of the insurgency, $I(t)$.

$$A_I = \gamma(\mu + (1 - \mu)I(t)) \quad (12)$$

This formula essentially splits the offensive efforts of the government into two parts: the effective (*aimed fire*) $\gamma\mu$ portion and the less effective (*guerrilla warfare area fire*) $\gamma(1 - \mu)I(t)$ portion. As we will see in the examination of A_{PG} , this less effective area fire portion of the government effort is directly related to the collateral damage caused by the government to the population. When the intelligence level approaches the

maximum of 1, then the government effort γ is completely effective in the sense that it is perfectly and effectively aimed at the insurgency only. Equation (12) then simplifies to the aimed fire Lanchester square law: $A_t = \gamma\mu$ where μ is 1. Recall that because the government forces do not suffer physical attrition, the government force level is constant throughout the model and can therefore be ignored. When intelligence is less effective and nears the minimum of 0, the government's attrition to the insurgency in equation (12) is based on the effort expended by the government and the size of the insurgency $\gamma I(t)$, as in the Deitchman guerrilla model: $A_t = \gamma\mu I(t)$. Recall that the insurgency parameter $I(t)$ is a number between 0 and 1 so that we are reducing the government effectiveness γ if we multiply by $I(t)$. This relationship rewards effective intelligence by the government and punishes early insurgency growth before they are prepared to effectively resist government COIN efforts. An insurgency must walk the tightrope of sustaining recruitment and offensive operations versus growing too big too fast. The larger an insurgency is in terms of size and effort the easier it is for the government to effectively target the insurgency.

Attrition against the population, A_p , can be broken down into two parts: attrition caused by either the insurgency A_{pI} or the government A_{pG} .

$$A_p = A_{pI} + A_{pG} \quad (13)$$

Attrition caused to the population by the insurgency is generally directed violence of the coercive sort: assassination of village leaders, doctors, and other important figures who represent a threat to the insurgency or who openly support the government. Generic violence against the population can also be useful to the insurgency by undermining government popular support by showing that the government cannot provide for the security of the population. In our model, this attrition is represented by the size of the insurgency at time t : $I(t)$, multiplied by an insurgent population attrition factor α_p , in practice usually a small number between 0 and 1, which represents the level of insurgency violence directed against the population.

$$A_{pI} = \alpha_p I(t) \quad (14)$$

The negative impact of coercion on attempts by the insurgency to gain popular support can undermine painstaking efforts to acquire that support. (O’Neill, 2005) There would seem to be a law of diminishing returns where a backlash would occur against an insurgency policy of extreme coercion to maintain popular support.

Attrition caused to the population by the government is usually collateral damage from poor intelligence and ineffective attacks against the insurgency. The insurgency can actually attempt to adopt strategies to increase collateral damage (urban warfare) to turn the population against the government. (O’Neill, 2005) Collateral damage can be broken down into the kinetic efforts the government is directing against the insurgency that “miss” the insurgency, random carpet bombing, and just plain bad intelligence. The model represents this attrition as a product of the government attrition coefficient, γ , the complement of the government intelligence factor, $(1 - \mu)$, and the complement of the size of the insurgency, $(1 - I)$, which effectively represents the non-insurgents who are suffering collateral damage from the government.

$$A_{PG} = \gamma(1 - \mu)(1 - I(t)) \quad (15)$$

The smaller the overall offensive effort, γ , the better the intelligence, μ , and the larger the size of the insurgency, $I(t)$, the smaller the overall collateral damage A_{PG} caused to the population as a whole. This collateral damage to the population is essentially the ‘area fire’ portion of the government effort $\gamma(1 - \mu)$ that does not hit the insurgency $(1 - I(t))$.

C. POPULATION DYNAMICS

The entire population pool in our model is divided into two classes: supporters and contrarians. Insurgents are a subclass of the contrarians. Individuals move between the supporter and contrarian classes based on the relationships in the transition equations where the change in the population balance depends on the size of both the supporter and contrarian populations multiplied by the transition parameter ρ_{SC} .

$$S' = \rho_{SC}SC \quad (16)$$

$$C' = -\rho_{SC}SC \quad (17)$$

Transitions from one population to another may results from contact between contrarians and supporters (Castillo Chavez and Song, 2004) and by word of mouth in rural areas.

The insurgency recruits directly from the contrarian population that are not yet insurgents ($C - I$). Active recruiting for the insurgency is in direct relation to the size of the insurgency $I(t)$, and the recruiting parameter ρ_{CI} . Total recruitment per time step is the interaction between the recruitment parameter and the respective sizes of $C(t)$ and $I(t)$.

$$\rho_{CI}(C - I)I \quad (18)$$

The recruitment parameter ρ_{CI} represents a positive change in the insurgency size reflecting the insurgency's ability and effort to recruit personnel. Successful attacks against the government and unsuccessful attacks against the insurgency (resulting in collateral damage) are events that could have a positive impact on this parameter, while visible attrition against the insurgency would similarly have a negative impact. One simple way to represent insurgency recruitment is where recruitment is a monotonically increasing function of A_G and A_{PG} and monotonically decreasing in A_I .

$$\rho_{CI} = A_G + A_{PG} - A_I \quad (19)$$

Kaplan and Jacobson (2006) assert that terrorist recruitment can be dependent on government actions and the planned future needs of the terrorists. In other words, smart terrorists will base their recruitment on planned future operations and not conscript forces just to increase their overall size and hence their signature as a target. Another complicated contributor to the recruitment parameter for the insurgency is the attrition caused to the population by the insurgency. This violence against the population can be characterized as coercion or targeted killings against government supporters. Coercion has its limits. Actions that victimize the population can undermine previous painstaking efforts to acquire support that apply on various combinations of techniques that avoid coercion. Mao recognized this and clearly articulated it in a code of conduct called "Eight Points of Attention," a "politeness" guide to avoid population resentment against the

insurgency. (O'Neill, 2005) It would be too simplistic to include insurgency attrition against the population as a negative contributor to their recruitment efforts. There is definitely a diminished and ultimately negative return for overly coercive and violent behavior. No matter who is causing the violence, the government is sure to shoulder much of the blame as one of government's primary responsibilities is the security of the population.

The population transition parameter, ρ_{SC} , is a snapshot of the popular will at any particular time. A positive parameter represents increased support for the government forces, while a negative parameter represents the opposite, increased support for the contrarians, and hence, the insurgency. A straightforward and simple way that the government or insurgency can influence the population opinion is by attriting the other side, with the assumption of perfect information by the population to determine who is causing the violence. Hence, ρ_{SC} is monotonically increasing in A_I and monotonically decreasing in A_G . There is an underlying assumption that the population transition follows a 'bandwagon' affect, that the side that seems to be winning gains the most support. There are conditions in which this may not be true (casualties to an insurgency incite more support from the population as in the Israeli/Palestinian conflict in the summer of 2006), but these situations are beyond the scope of this thesis.

The security of the population is also of prime importance. Historically, the critical test of legitimacy is the ability of one side or the other to guarantee the security of the population; the government must demonstrate that it can fight the insurgency effectively while also protecting the population. (Lynn, 2005) This includes minimizing collateral damage (A_{PG}), and protecting the population from the violence caused by the insurgents (A_{PI}). The effect of Government collateral damage against the population is generally pretty straightforward; ρ_{SC} is monotonically decreasing in A_{PG} . Attrition against the population by the insurgency can have a more complicated effect. The perception of the population is of prime importance. Is the insurgency at fault for having attacked the population or is the government at fault for failing to protect the population from the insurgency? A_{PI} is therefore a more complicated portion of the population

influence that would seem to depend on additional factors. A basic additive model could have the attrition to the population caused by the insurgency increase popular support for the government or create more contrarians (hence the \pm sign in equation 20).

$$\rho_{SC} = A_I \pm A_{PI} - A_G - A_{PG} \quad (20)$$

Finally, we have the total insurgency strength change over time. This equation represents the attrition caused to the insurgency by the government, equation (12), and the recruitment the insurgency gained in the last time period, equation (18).

$$I' = -A_I + \rho_{CI}(C - I)I \quad (21)$$

The insurgency must overcome the attrition caused by the government with positive recruitment from its base supporting population, the contrarians.

D. COMPLETE MODEL

The complete system of differential equations for the insurgency model follows:

$$\begin{aligned} \frac{dS}{dt} &= \rho_{SC}SC \\ \frac{dC}{dt} &= -\rho_{SC}SC \\ \frac{dI}{dt} &= -A_I + \rho_{CI}(C - I)I \end{aligned}$$

where:

$$\begin{aligned} A_G &= \alpha_G I \\ A_I &= \gamma(\mu + (1 - \mu)I) \\ A_P &= A_{PI} + A_{PG} \\ A_{PG} &= \gamma(1 - \mu)(1 - I) \\ A_{PI} &= \alpha_P I \end{aligned} \quad (22)$$

A couple of notes about the complete model: as noted, $0 \leq S(t) \leq 1$, $0 \leq C(t) \leq 1$, $0 \leq I(t) \leq 1$ and $I(t) \leq C(t)$. Also recall that $S(t) + C(t) = 1$. The intelligence parameter, $0 \leq \mu \leq 1$, is directly dependent on the amount of support the government has among the population.

IV. ANALYSIS

A. PURPOSE AND METHODOLOGY

The analysis of our model is going to focus on the interaction between the insurgency attrition and the population dynamics. The primary purpose of our analysis is to attain operational insights with regard to fighting and defeating an insurgency. We use real world data from the current conflict in Iraq to estimate parameters regarding attrition rates, insurgency recruitment rate, government intelligence and response efforts, and population dynamics.

Our methodology consists of the following steps: (1) analysis of available Operation Iraqi Freedom (OIF) data, (2) determining a set of parameters and functions based on the OIF data and specifying time resolution, (3) implementing a basic model and (4) implementing an advanced model.

1. Analysis of OIF Data

The OIF conflict has evolved in two phases: the American led coalition effort to remove Saddam Hussein from power in March 2003, and the subsequent attempts to stabilize the country and establish a democratic Iraqi government. In this thesis we focus on the second phase: the stabilization portion of this conflict. There is a host of information available about the current conflict in Iraq. The data is current, well documented, widely available, and generally unclassified. While the conflict in Iraq may not exactly fit the strict definition of an insurgence because of the sectarian violence and American presence and responsibility for the conflict, it contains many of the elements of an insurgency: an internal nonruling group utilizing guerrilla warfare and terrorist tactics against both the government and the population to destroy or reformulate one or more aspects of the ruling faction. We recognize that the data does not derive from a prototypical insurgency.

Information about OIF is widely available but there is widely differing opinions about the validity of some of the data. Statistics about coalition force levels and coalition casualties are available from the Department of Defense (DOD) and this information is very accurate. Iraqi government military and para-military force strength and casualty data is less reliable. Some of this data is skewed for political purposes as the size and quality of these forces are considered an important benchmark representing the ability of the Iraqi government to secure the country and allow American forces to depart.

The last few data elements in which we are most interested are the most difficult to collect and few agencies agree about its accuracy: Iraqi population casualties and insurgency size and casualties. During most asymmetric conflicts it is very difficult to exactly determine the size and strength of insurgencies. Estimations can be made based on violence and activity levels and numbers of insurgents killed or captured, but these statistics can be misleading. The Iraqi population casualty data suffers from a different problem: politicization of the war. The number of deaths of civilians in Iraq during OIF differs by an order of magnitude in some reports: from 60,000 to over 600,000. (O'Hanlon & Campbell, 2007) The high end (600,000+) figures were reported by a British online medical journal (Karadsheh, 2006) a month ahead of 2006 American Congressional elections and have generally not gained wide acceptance. Most reasonable forums report numbers closer to the 50-80,000 range. These numbers agree with the politically active website Iraq Body Count. (Dardagan, 2007)

Our primary source for data about the conflict in Iraq was supplied by the Department of Defense Center for Army Analysis (CAA) in Fort Belvoir, Virginia. A significant portion of the unclassified CAA data on the OIF conflict is collected from The Brookings Institute (O'Hanlon & Campbell, 2007) and their monthly Iraqi Index document. The Iraqi Index is a statistical compilation of economic, public opinion, and security data providing updated information on various criteria, including crime, telephone and water service, troop fatalities, unemployment, Iraqi security forces, oil production, and coalition troop strength. (O'Hanlon & Campbell, 2007) Our primary reference for the Iraqi population casualty data is the political website Iraq Body Count. (Dardagan, 2007) Although this is a political website operated by individuals with strong

opinions about the war in Iraq, their data is well documented and investigated. Each casualty is listed by date, location, cause of death and the original media source where the website obtained the data. Multiple casualties caused during one incident are recorded by their minimum and maximum reported values when there is any question about how many people were actually killed in an attack. The OIF data that we use in this analysis is listed in Appendix A.

2. Initial Parameters and Time Resolution

An important part of the analysis is determining realistic initial values for the parameters in the model. The initial values are based on data from OIF. The parameters we consider are:

α_G : the insurgency attrition coefficient against the government. This parameter remains constant in both basic and advanced models.

α_P : the insurgency attrition coefficient against the population. This parameter remains constant in both basic and advanced models.

γ : the government attrition coefficient against the insurgency. This parameter remains constant in the basic model but becomes variable in the advanced model.

ρ_{CI} : the recruitment rate for the insurgency. This parameter remains constant in the basic model but becomes variable in the advanced model.

$I(0)$: the initial portion of the population that is part of the insurgency.

$S(0)$: the initial portion of the population that supports the government.

$C(0)$: the initial portion of the population that supports the insurgency.

Both the government effort against the insurgency γ and the insurgency recruitment parameter ρ_{CI} are held constant in the basic model shown in Section B. This assumption will be relaxed in the advanced model presented in Section C.

Our primary goal in the analysis of the OIF data is to determine “ballpark” initial conditions to start the insurgency and population model. This analysis is not an in-depth statistical analysis and arguments can be made for utilizing other methods of examining the data.

The first three initial conditions are the division of the starting population between government supporters and contrarians, $S(0)$ and $C(0)$, and the initial proportion of the insurgency in the population, $I(0)$. The initial division of the population is determined by a public opinion poll of Iraqi civilians during the beginning OIF. (O’Hanlon & Campbell, 2007) In this opinion poll 66% of the population agreed with the direction the country was heading. We can tenuously translate this to 66% initial support for the government. The initial proportion of the insurgency in the population is obtained by dividing the initial size of the insurgency (3500 individuals in May 2003) (O’Hanlon & Campbell, 2007) by the total population of Iraq (26M): $I(0) = 0.000135$.

Next we estimate the insurgency attrition coefficients against the government and against the population, α_G and α_p respectively. Recall the attrition equations (8) and (14) in Chapter III for the violence against the government and the violence against the population caused by the insurgency. Solving for the attrition parameters α_G and α_p results in the following equations:

$$\alpha_G = \frac{A_G}{I(t)} \tag{23}$$

$$\alpha_p = \frac{A_{PI}}{I(t)}$$

The Iraqi population casualty from the Iraq Body count database (Dardagan, 2007) does not differentiate between who caused the violence. However, according to the United States military, the collateral damage rate by the coalition forces is approximately 7 civilians killed per week in 2005, 4 civilians per week in the first half of 2006, and 1 per week in the last half of 2006. (O’Hanlon & Campbell, 2007) This attrition to the population is not negligible and will have to be removed from the total population casualty data. With these equations we can estimate the attrition coefficients α_G and α_p

by utilizing the data in Appendix A and dividing the average number of casualties suffered by the government and the population from May 2003 until March 2007 (197 and 1240 respectively) by the average size of the insurgency from May 2003 until March 2007 (19595). (O’Hanlon & Campbell, 2007) These final estimates are $\alpha_G = 0.0101$ and $\alpha_p = 0.0633$.

In the basic model, the insurgency recruitment and the government attrition coefficient are fixed throughout and will be calculated by utilizing the data in Appendix A. The average rate of change in the size of the insurgency is used to roughly estimate the parameter ρ_{CI} . Let ΔI denote the average monthly rate of change over the period May 2003 to March 2007. Then (see Equation (18) in Chapter III) we approximate

$$\Delta I \approx \rho_{CI}(C(0) - I(0))I(0) \quad (24)$$

Solving for the recruitment parameter yields:

$$\rho_{CI} \approx \frac{\Delta I}{(C(0) - I(0))I(0)} \quad (25)$$

The average change in the insurgency size over the period May 2003 until March 2007 is 1446 individuals (see Appendix A). We divide this figure by the total population to bring it to our scale. Thus, $\Delta I = 0.000056$. The initial contrarian and insurgency parameters were calculated above: $C(0) = 0.33$ and $I(0) = 0.000135$. We can now calculate a ballpark figure for the recruitment parameter:

$$\rho_{CI} \approx \frac{.000056}{(0.33 - .000135) \cdot 0.000135} = 1.25$$

Now to estimate the government attrition coefficient we solve equation 12 in Chapter III for γ

$$\gamma = \frac{A_I}{G[\mu + (1 - \mu)I]} \quad (26)$$

Here G is the actual size of the government force, A_I is the average monthly attrition sustained by the insurgency (see Appendix A), I is the average insurgency strength, and the intelligence level μ is assumed to be 0.5. The average coalition force plus the Iraqi government force is 335,000 (see Appendix A), the average insurgency strength is 19595, and the average attrition sustained by the insurgency, A_I , is 215 per month. Utilizing equation 26 we obtain $\hat{\gamma} = \frac{215}{335,000[.5 + (1-.5)19595]} = .0000000655$ or 6.5×10^{-8} . Since we normalize for the government force, and assume $G=1$ throughout, we need to multiply $\hat{\gamma}$ by 335,000 to obtain $\gamma = .022$. Once again, we are interested in obtaining ballpark figures for these parameters, not predicting outcomes.

All of OIF data is broken down in terms of months so our initial parameters are monthly rates. We will examine the behavior of the insurgency strength and the popular support over a reasonable period of time (around 60 months or 5 years). In certain cases it will be interesting to examine the behavior of the model over a longer time period to see if the model outcome changes over extended periods of time.

3. Basic Model Setup

In the basic model we assume that the government attrition coefficient γ and the insurgency recruitment parameter ρ_{CI} are constants. The other parameters that dynamically change over time are the intelligence parameter μ , which depends on popular support, and the population transition parameter ρ_{SC} , which depends on the various types of attrition. Initially we will assume a linear relationship between the intelligence level μ and the popular support of the government S . Our initial assumption for the population transition parameter will be a simple additive function of the population, government, and insurgency attrition values: $\rho_{SC} = A_I - A_G - A_P$. Basically, both the insurgency and the government lose support whenever they experience casualties. Recall that A_P is the total attrition to the population: $A_P = A_{PI} + A_{PG}$.

4. Advanced Model Setup

In the advanced model the government attrition coefficient γ and the insurgency recruitment parameter ρ_{CI} are no longer constant. Each is represented by a function of the government, insurgency, and population attrition. All of the other initial conditions are the same as in the basic model.

B. BASIC MODEL

The parameters and functions for the base run of the basic model are summarized in Table 1.

Parameter	Equation/Value
α_G	0.0101
α_P	0.0633
ρ_{CI}	1.25
γ	0.022
$S(0)$	0.66
$C(0)$	0.34
$I(t)$	0.000135
ρ_{SC}	$A_I - A_G - A_P$
μ	S

Table 1. Initial Functions and Values for the Basic Model

With our initial conditions and parameters we recursively iterate over a period of 60 time units (60 months) and observe the following plots of the population ratios and insurgency strength (Figures 4 and 5). Based on the plots in Figure 4 and 5, there seems to be little change in the population dynamics (Figure 4) but after 36 months the insurgency begins steady growth (Figure 5).

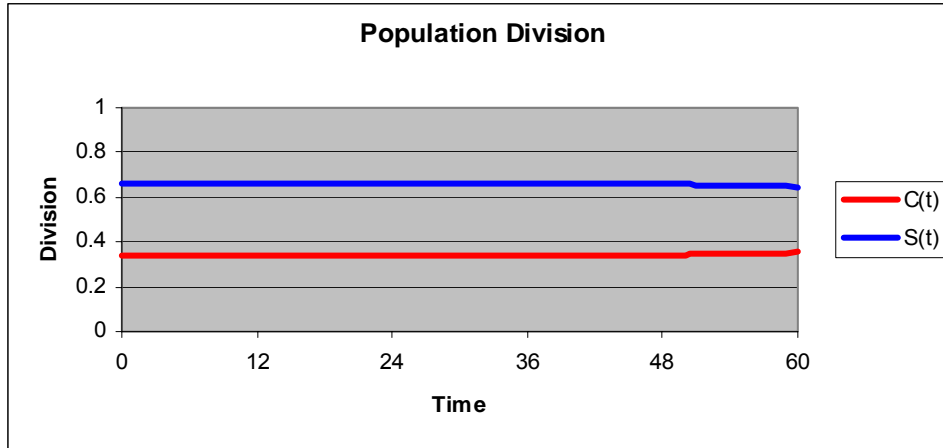

Figure 4. Population Division in Base Run (60 months): Basic Model

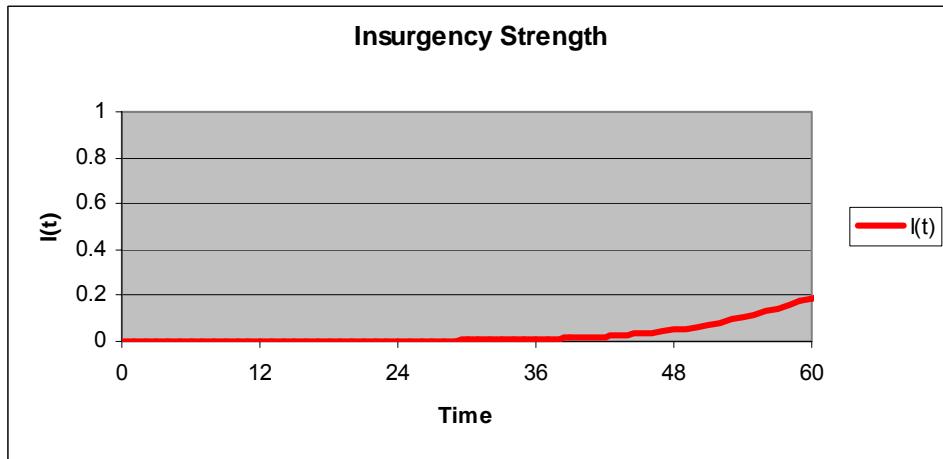

Figure 5. Insurgency Strength in Base Run (60 months): Basic Model

If there is no change in the dynamics of the conflict, we can expect the insurgency to continue growing until they displace the government. Figure 6 and 7 show the model extended out to 120 months. As expected, the insurgency continues to grow and reaches almost 100% of the contrarian strength (0.57 versus 0.59). This is an idealized scenario as the government would collapse long before the insurgency reached this size.

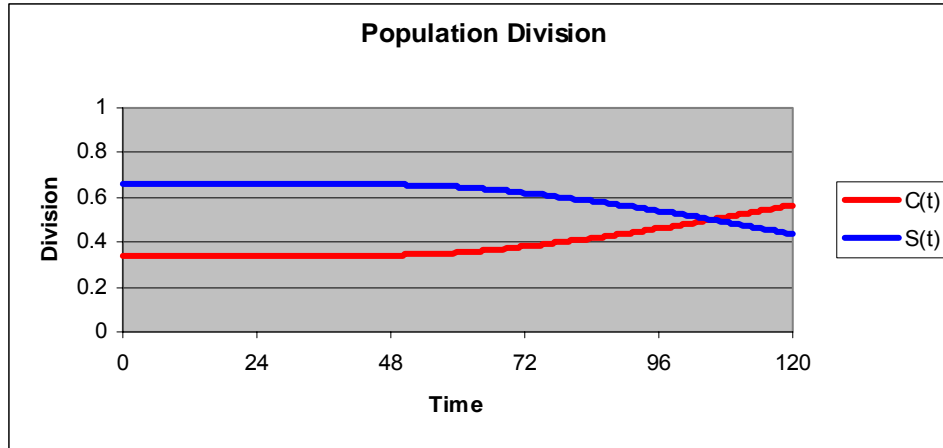

Figure 6. Population Division in Base Run (120 months): Basic Model

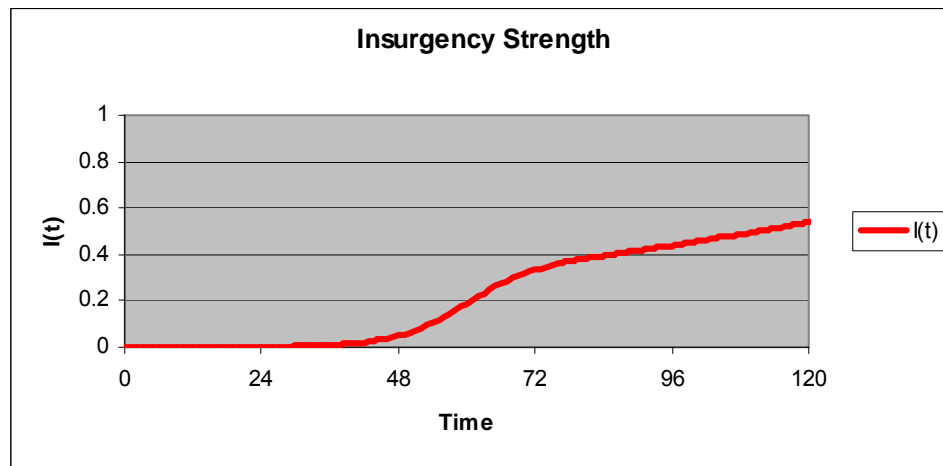

Figure 7. Insurgency Strength in Base Run (120 months): Basic Model

The insurgency strength $I(t)$ does not follow a simple curve in Figure 7. While $I(t)$ is monotonically increasing it suffers a slowing of growth around month 72. This is a result of the initial growth of the insurgency outpacing the initial contrarian growth in the population. The insurgency quickly reaches a size where they are unable to recruit effectively from the contrarian population. Recall that the total recruitment for the insurgency is $\rho_{CI}(C - I)I$. When I approaches C , the $C - I$ portion of this equation approaches 0 and the insurgency total recruitment approaches 0 too. At month 50 we see an increase in the slope of the graph of the contrarian support in Figure 6, so the insurgency success begins to feed off of this increased contrarian support. Success breeds

more success and the population quickly begins to support the insurgency. Figure 8 is a graphic illustration of the initial interaction between the insurgency and the non-insurgency contrarians $(C - I)I$.

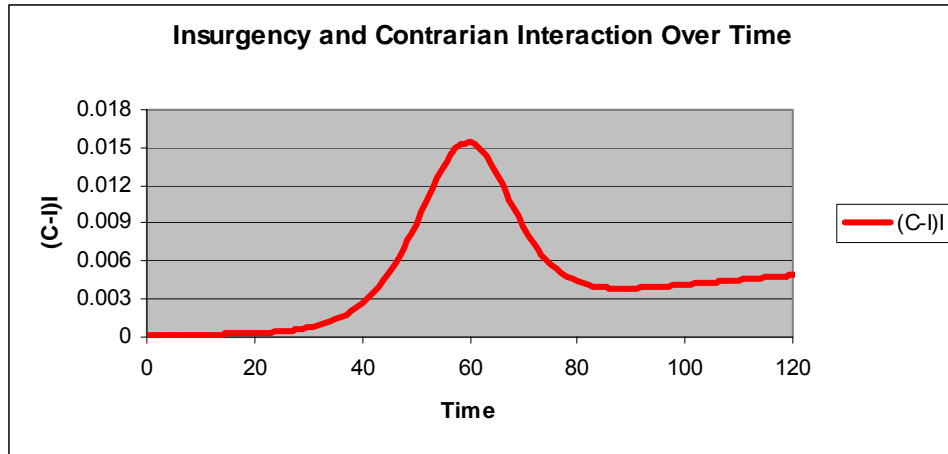

Figure 8. Insurgency and Contrarian Interaction over Time

Figure 8 shows that initially (months 0 to 60) the insurgency/contrarian interaction experiences a sharp spike. As the insurgency grows it outpaces the contrarians' abilities to provide fresh recruits (months 60 to 80). The insurgency success begins to fuel contrarian support in the population (after month 50 in Figure 6) and the pool of recruits for the insurgency begins to grow again (after month 80 in Figure 8). This dramatic growth followed by a dramatic decline in growth is an interesting aspect of the model and could represent a situation where the insurgency may be growing too big too quickly. The overall growth of the insurgency is limited by the size of the contrarian support in the population. In this base run of the basic model the government is unable to take advantage of this fact.

We demonstrate the importance of intelligence μ by examining the outcome of the conflict utilizing different intelligence parameters μ . In the base run of the basic model we assume that the intelligence parameter is linearly dependent on the government support in the population, $\mu = S$. In Chapter III we presented other possible functions (Figure 3 in Chapter III) that could also represent this intelligence parameter. We could

improve the intelligence return from the supporting population by representing the intelligence parameter as a concave function of the popular support to the government S . This means that the government receives good intelligence unless they have very little support in the population. The alternative to the increased intelligence from the supporting population is the convex function. The concave and convex intelligence functions were derived based on the following equations (see Chapter III, Figure 3):

$$\text{Concave: } \mu(S) = \frac{1 - e^{-\beta S}}{1 - e^{-\beta}} \quad (27)$$

$$\text{Convex: } \mu(S) = S(t)e^{-\beta(S-1)} \quad (28)$$

By adjusting the β parameter in each equation we can adjust the convexity or concavity of the intelligence equation. Figure 9 graphically shows the concave and convex intelligence functions when $\beta = 5$.

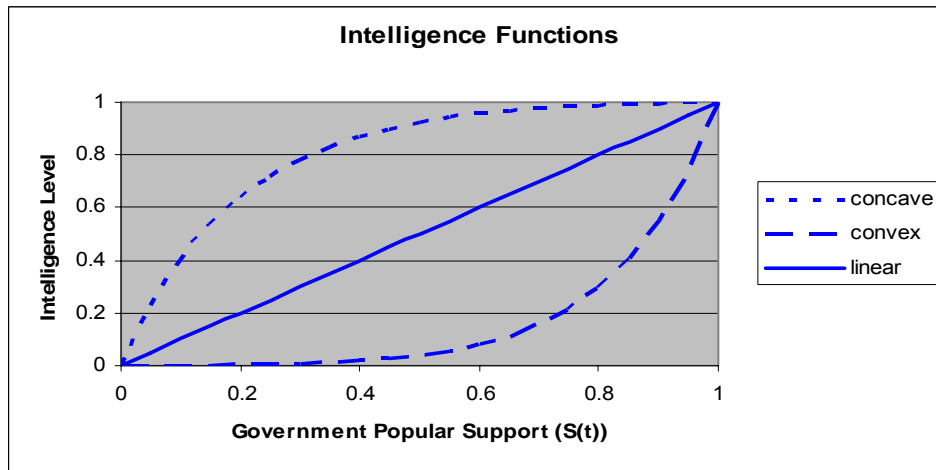

Figure 9. Concave, Linear and Convex Intelligence Functions for $\beta = 5$.

Figure 10 present the intelligence functions when $\beta = 0.5$.

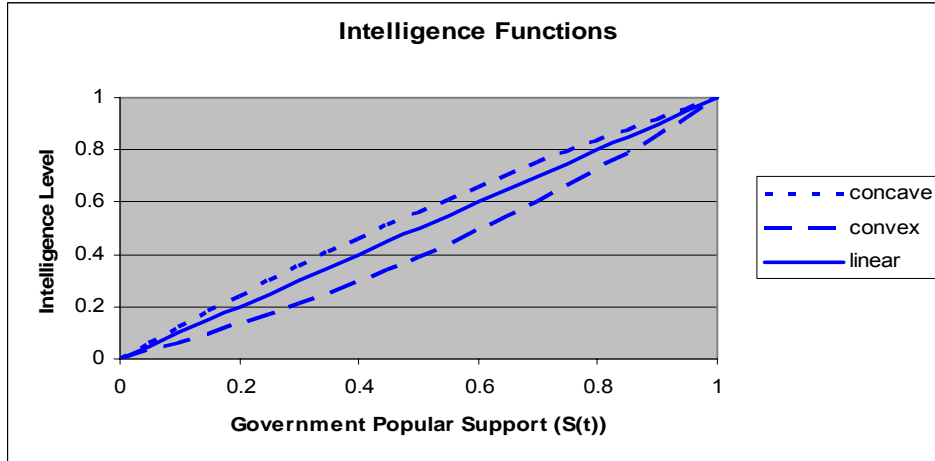

Figure 10. Concave, Linear and Convex Intelligence Functions for $\beta = 0.5$

This change in the way we view the effect of population support on the availability of good intelligence to the government results in dramatically increased intelligence for the government and a quick defeat for the insurgency (the thick line at the bottom of Figure 11). A convex intelligence function (dashed line in Figure 11) has the opposite effect; it increases the growth of the insurgency in a shorter amount of time. This analysis of intelligence in the base model leads to a couple of interesting insights: (a) the model portrays the affects of an increased or decreased intelligence ability of the government and (b) increasing or decreasing the intelligence ability of the government has a strong impact on the outcome of the model. (Note the change in the Y-scale of Figure 11 from 1 to 0.5).

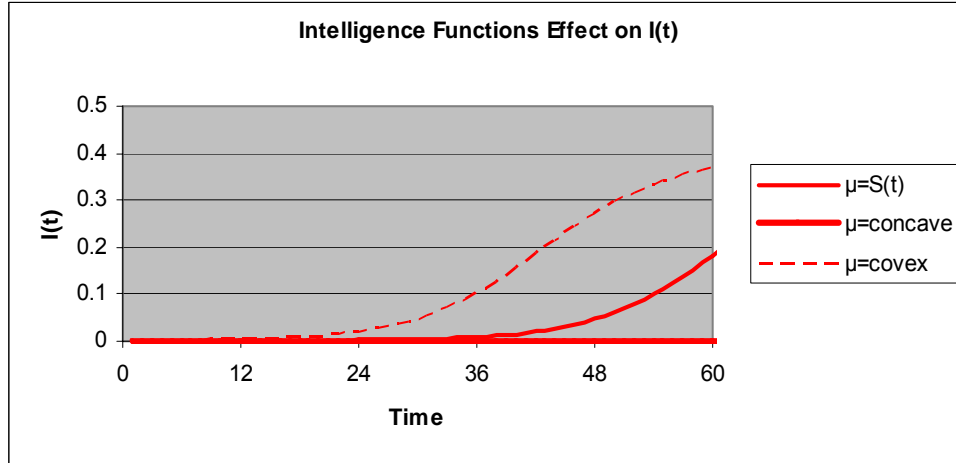

Figure 11. Intelligence Functions Effect On $I(t)$ in Base Model ($\beta = 5$)

The population transition ρ_{SC} is the most complex parameter we attempt to model. The decision by an individual to support the government or support the insurgency can be extremely complex. The most important model factors that affect this decision are the perception of who is winning the conflict and who is causing the violence against the population. In our basic run we assume that the government is held responsible by the public for all of the violence committed against the population. This seems reasonable as the prime responsibility of the government is the security of the population. If the government is able to convince the population that the insurgency is responsible for the violence then we have a new population transition parameter, $\rho_{SC} = A_I + A_{PI} - A_G - A_{PG}$. The results of this change in the population parameter on the strength of the insurgency are graphically displayed in Figure 12. (In this run of the basic model we have returned to the initial intelligence parameter of $\mu = S$).

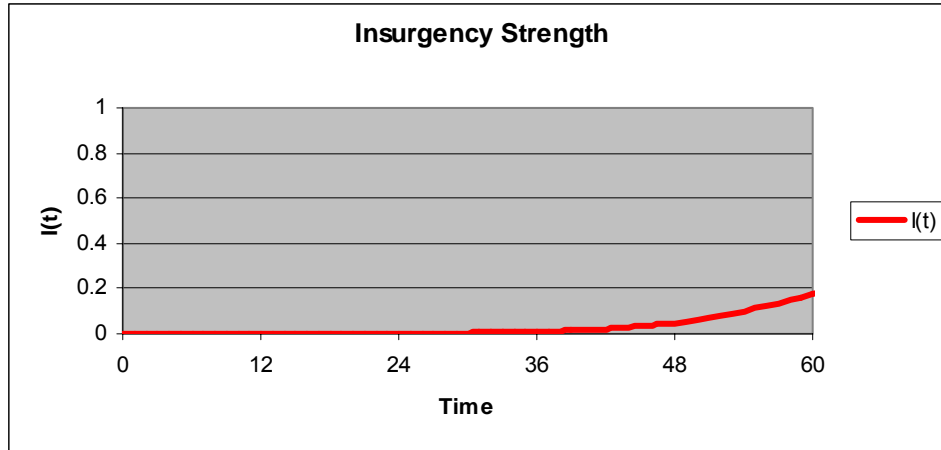

Figure 12. Base Model $I(t)$ with $\rho_{SC} = A_I + A_{PI} - A_G - A_{PG}$ (60 months)

There seems to be no slowing of the growth of the insurgency with the new population parameter ($\rho_{SC} = A_I + A_{PI} - A_G - A_{PG}$). If we extend the time horizon to 120 months we achieve the results in Figure 13.

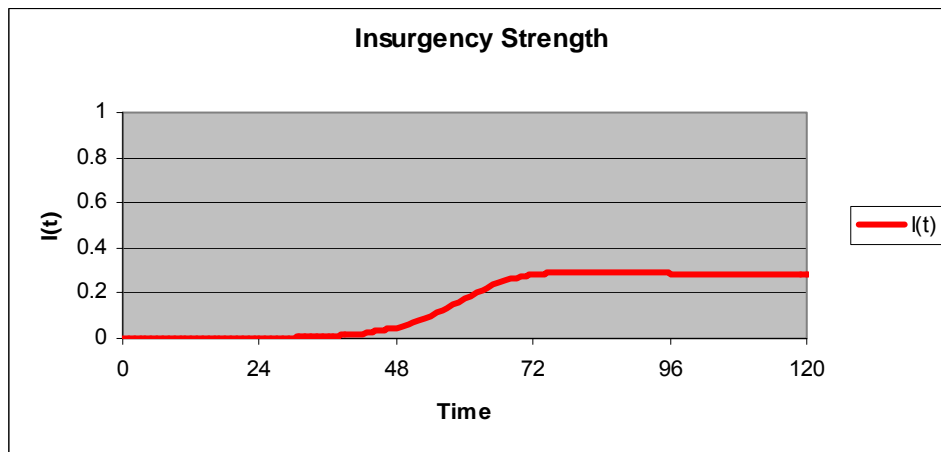

Figure 13. Base Model $I(t)$ with $\rho_{SC} = A_I + A_{PI} - A_G - A_{PG}$ (120 months)

This is an interesting situation where the insurgency enjoys initial success but begins to suffer a very gradual decline in strength. The reason for this decline is explained by the population dynamics represented in Figure 14. The new population transition parameter $\rho_{SC} = A_I + A_{PI} - A_G - A_{PG}$ has completely changed the outcome of the contrarian and government popular support. Support level for the government is now

monotonically increasing while contrarian support is monotonically decreasing. Contrast Figure 13 where the government has started to reverse the growth of the insurgency after 80 months to Figure 7 where the insurgency experienced virtually unchecked growth. The challenge to the government is to affect this change in a reasonable amount of time before the government is defeated.

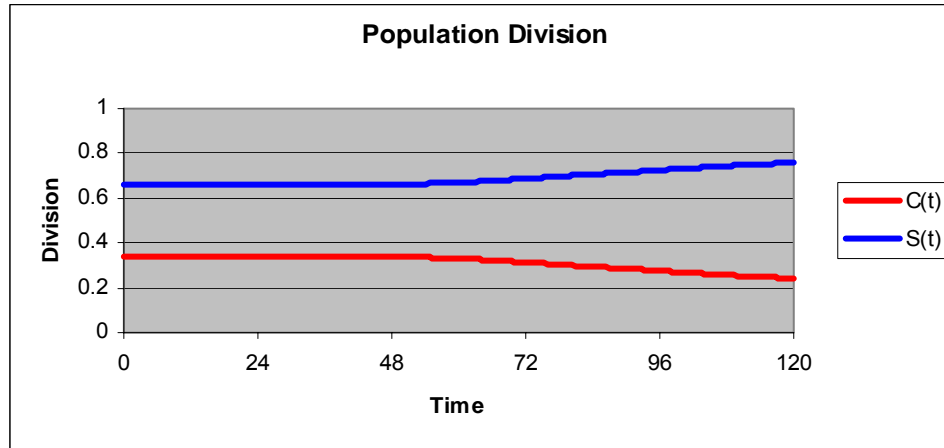

Figure 14. Base Model Population Division with $\rho_{SC} = A_I + A_{PI} - A_G - A_{PG}$

C. ADVANCED MODEL

This model has the same difference equations as the basic model (Equation 22 in Chapter III). We now introduce more complexity into the government attrition effort, γ , and the insurgency recruitment, ρ_{CI} , which were held constant in the basic model case. This increased complexity is accomplished by making these two parameters dynamic and dependent on the population, government and insurgency attrition. We will start with basic additive functions of the attrition parameters, much like the initial function for the population transition parameter in the basic model ($\rho_{SC} = A_I - A_G - A_p$).

The government efforts to attrite the insurgency depend on the insurgency violence against the government and the overall violence against the population. A logical assumption is that government efforts against the insurgency increase with increased violence against the government and the population by the insurgency. Also, a

general outcry from collateral damage caused by the government could curtail government efforts against the insurgency. Initially we assume a linear additive relationship: $\gamma = A_G + A_{PI} - A_{PG}$. This equation can be modified for a more complex relationship. The overall government effort is a response to insurgency violence against the government while placing a premium on protecting the population from insurgency violence and collateral damage. This is accomplished by increasing the government efforts when the insurgency attacks the government or the population, and reducing government efforts when there is collateral damage.

It is reasonable to assume that the recruitment for the insurgency will follow in a manner similar to the population transition from supporters to contrarians. Attrition to the insurgency is embarrassing and leads to defeat while attrition to the government and collateral damage by the government draws recruits (both contrarians (C) and insurgents (I)). Modeling the effect of attrition to the population by the insurgency on ρ_{CI} is more complicated. Initially we assume that these coercive efforts against the population are successful and/or the government takes the blame for the insurgency violence against the population. These assumptions lead to the following recruitment parameter: $\rho_{CI} = \delta(A_G + A_p - A_I)$, where δ is a scaling factor. The scaling is necessary because of the quadratic nature of the recruitment function (Equation 18 in Chapter III). Table 2 shows the complete list of parameter values and functions for the advanced model.

Parameter	Equation/Value
α_G	0.0101
α_p	0.0633
ρ_{CI}	$\delta(A_G + A_p - A_I)$
γ	$A_G + A_{PI} - A_{PG}$
$S(0)$	0.66
$S(0)$	0.34
$I(0)$	0.000135
ρ_{SC}	$A_I - A_G - A_p$
μ	S

Table 2. Initial Functions and Values for the Advanced Model

The δ portion of the recruitment function ρ_{CI} is a scaling constant that is set to 250 throughout the advanced model. We once again iterate over 60 months and graphically display the results of the conflict in Figures 15 and 16. Once again the popular support seems to be unchanged while the insurgency is gaining strength. In the advanced model the insurgency experiences increased growth after month 36 (Figure 16). This growth seems to flatten out at the 60 month mark (Figure 16).

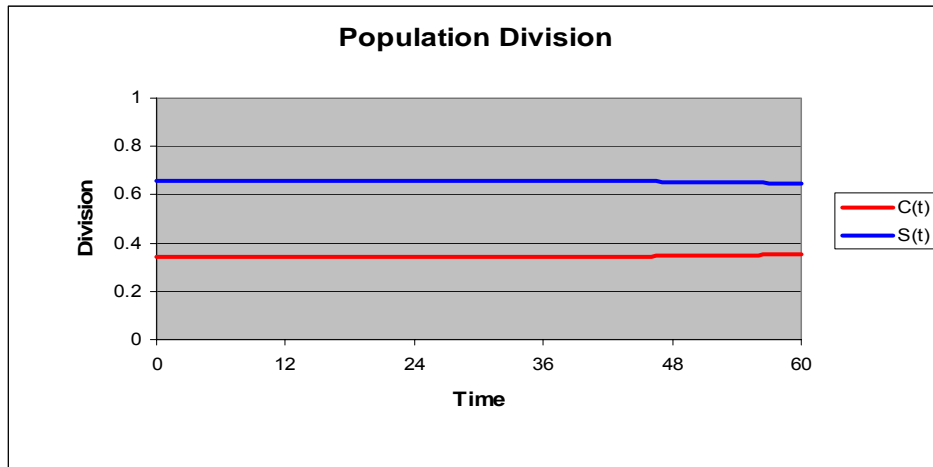

Figure 15. Population Division in Base Run of Advanced Model

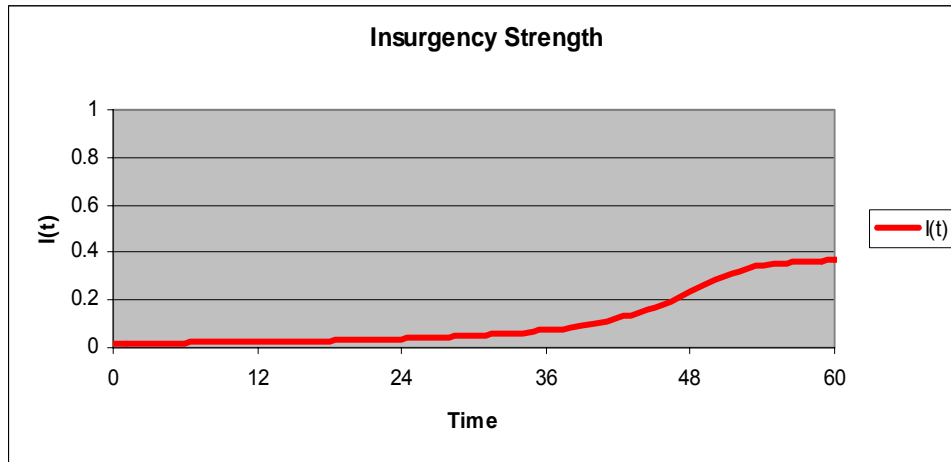

Figure 16. Insurgency Strength in Base Run of Advanced Model

If we extend the run of the base run of the advanced model out to 120 months we achieve the results in Figures 17 and 18. Figure 18 verifies that the growth of the insurgency has slowed but not stopped. The knee in the curve of the insurgency growth

(much like the basic model in Figure 7) is partially explained by the interaction between the insurgency and the contrarians in the population (Figure 19).

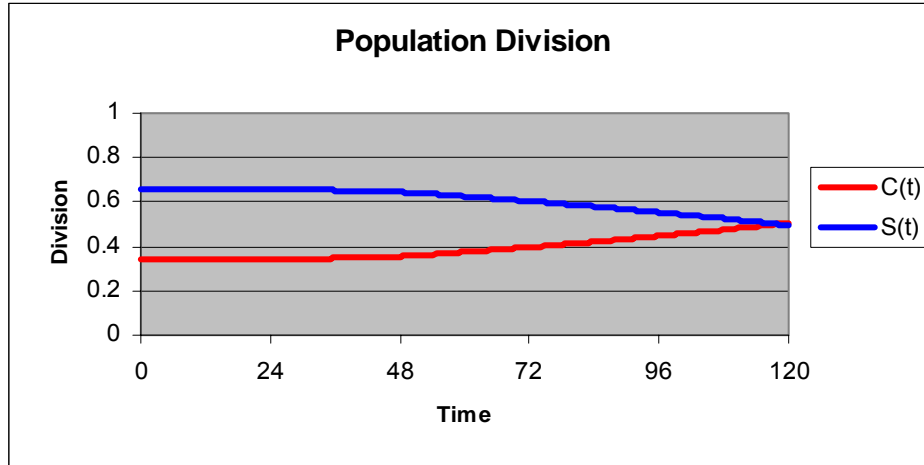

Figure 17. Population Division in Base Run of Advanced Model

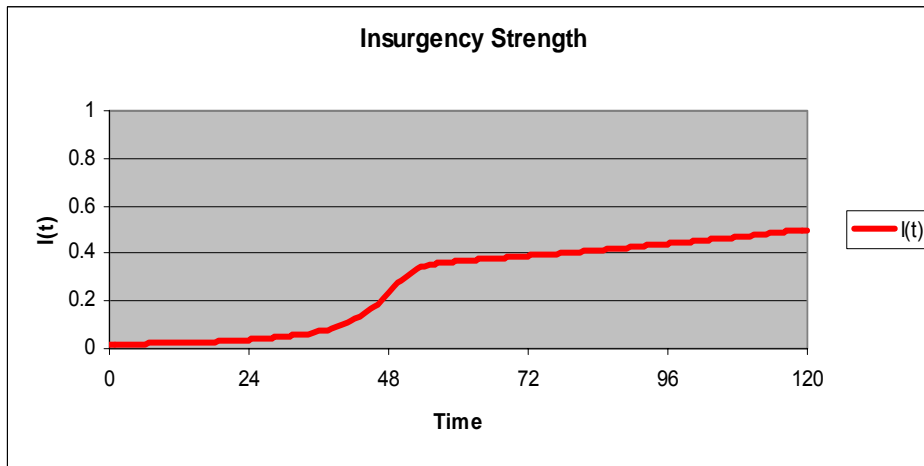

Figure 18. Insurgency Strength in Base Run of Advanced Model

As in the base model, the insurgency initially has a large pool of contrarians to recruit from. After month 48 in Figure 19 the insurgency has once again outgrown their support and they must wait for the contrarian support in the population to increase. At this point the interaction between the insurgents and non-insurgent contrarians begins to decline (month 48-60 in Figure 19) and remains constant after 60 months.

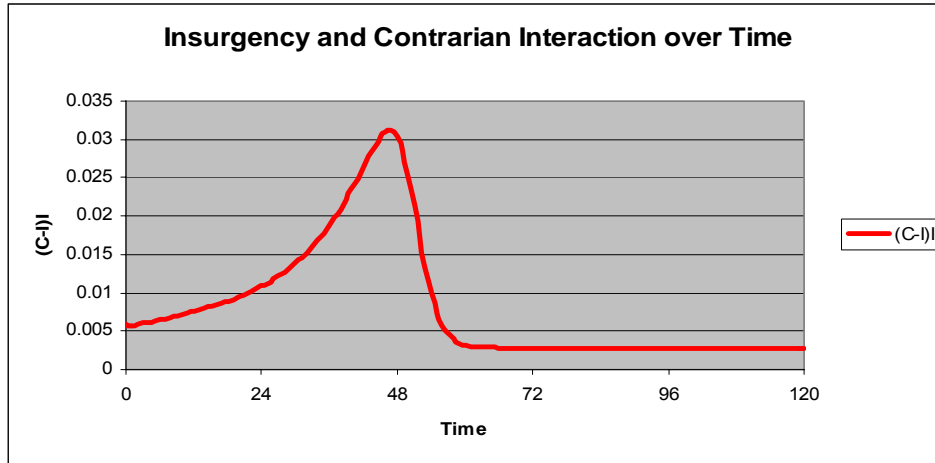

Figure 19. Insurgency and Contrarian Interaction over Time, Advanced Model

With a base run of both the basic and advanced model we can now compare and contrast the two models. The outcome of the strength of the insurgencies over the first six months is significantly different. The insurgency in the base model reaches a size of 0.2 while the insurgency in the advanced model reaches a size of 0.39. Both insurgencies suffer a significant slowing of their growth: after 48 months in the advanced model (Figure 18) and after 72 months in the basic model (Figure 7). The variable recruitment and government effort parameters in the advanced model seem to have improved the growth of the insurgency (to 0.48 in Figure 16). Both models suffer from a slowing of insurgency growth due to the insurgency outgrowing their contrarian support. We can now continue our analysis of the advanced model by examining the intelligence, population, recruitment, and government effort parameters.

As in the base model we can examine the effect of different intelligence parameters on the advanced model. Figure 20 shows the results of utilizing the same concave, convex and linear in $S(t)$ intelligence functions with $\beta = 5$. It is no surprise that we achieve essentially the same results as in the basic model: a faster increase in insurgency strength for a convex function and another quick defeat for the insurgency with the concave function. (Once again note the change in the Y-scale of Figure 20 from 1 to 0.5).

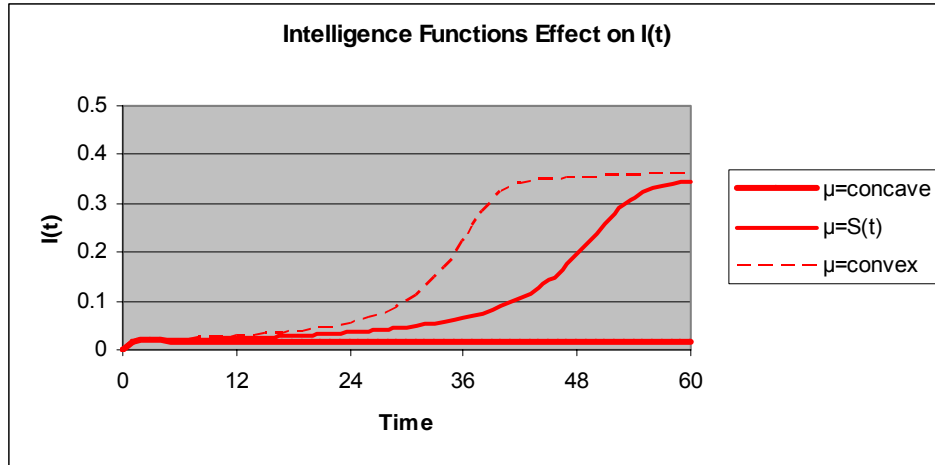

Figure 20. Intelligence Functions Effect On $I(t)$ in Advanced Model

Next we examine the effect on the advanced model if we take the attrition against the population caused by the insurgency and turn it against the insurgency (as we did in the basic model: $\rho_{SC} = A_I + A_{PI} - A_G - A_{PG}$). There is very little change in the results when we change the population transition parameter (Figure 21). (Once again we have returned to the original intelligence parameter of $\mu = S(t)$).

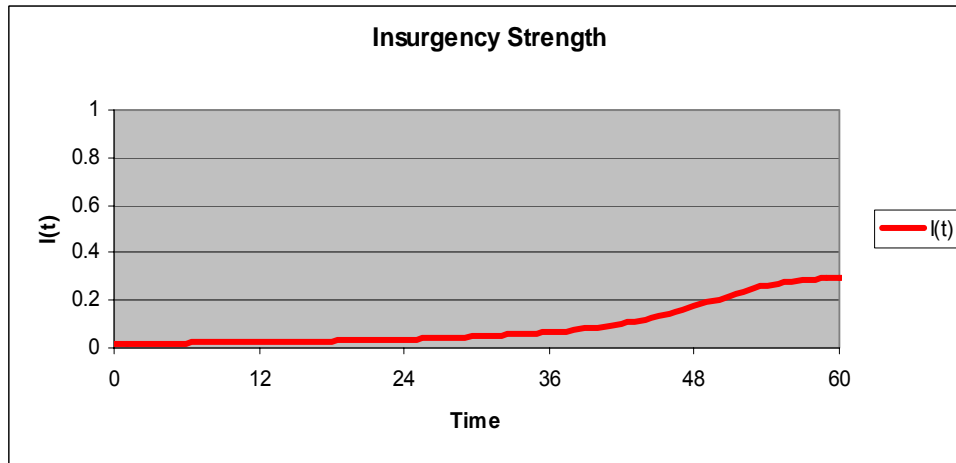

Figure 21. Advanced Model $I(t)$ with $\rho_{SC} = A_I + A_{PI} - A_G - A_{PG}$ for 60 months

If we extend the time horizon to 120 months (Figure 22) we see that the government has slowly begun to defeat the insurgency.

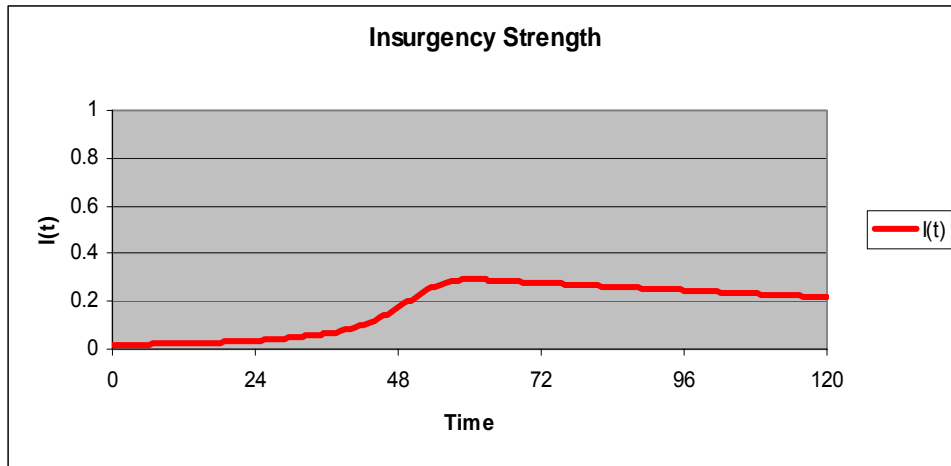

Figure 22. Advanced Model $I(t)$ with $\rho_{SC} = A_I + A_{PI} - A_G - A_{PG}$ for 120 months

In the OIF data the attrition caused to the population by the insurgency is an order of magnitude bigger than the attrition caused to the government by the insurgency. Switching who the population blames for the attrition against the population has a very strong impact on the outcome of the population becoming either contrarians or supporters of the government (Figure 23). This is not unrealistic as we see similar arguments about insurgency violence against the population in Iraq today. The population grows angry at both the insurgency for causing the violence and also with the government for failing to provide adequate security. The net effect in the advanced model is a reduction in contrarian support and ultimate defeat of the insurgency.

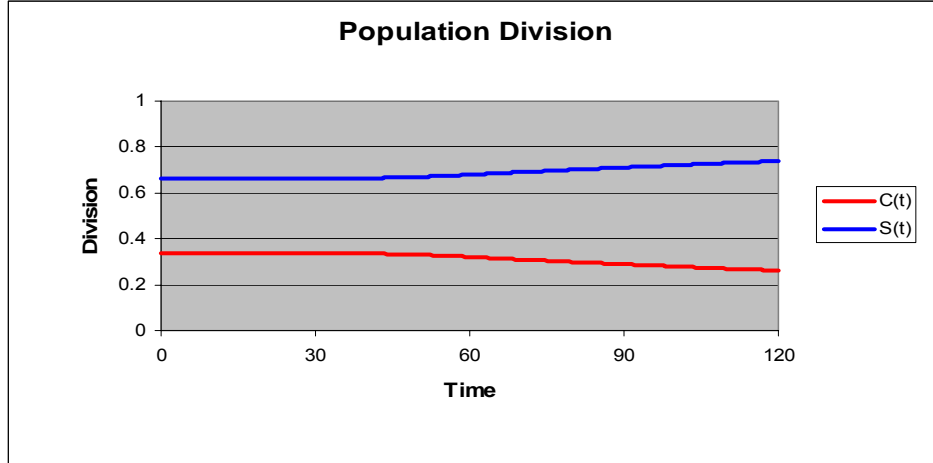

Figure 23. Advanced Model Population Division with $\rho_{SC} = A_I + A_{PI} - A_G - A_{PG}$

Recall that in the advanced model we have replaced the constant recruitment and government effort by variable functions. We can now examine the sensitivity of these dynamic parameters γ and ρ_{CI} . Our analysis of these parameters allows us to examine very simple conflict scenarios and policy actions by both the insurgency and the government.

The insurgency recruitment ρ_{CI} is affected by a host of factors. In the basic model this parameter was constant. In addition to the base function $\rho_{CI} = \delta(A_G + A_P - A_I)$, we examine two specific recruitment policies/scenarios: opportunistic recruitment (the bandwagons effect) and idealistic recruitment.

Opportunistic recruitment can be defined as individuals joining the “cause” because the insurgency seems to be winning, or at least doing better than the government. This function then depends on the relative “institutional attrition” to the government and the insurgency: $\rho_{CI} = \varepsilon \left(\frac{A_G I(t)}{A_I} \right)$. (Recall that the actual government strength throughout the model is defined as a constant which is taken to be 1.)

The idealistic recruitment scenario can be modeled based on the “activity” level of the insurgency. In this case the recruitment parameter ρ_{CI} would be proportional to the

total violence in the conflict: $\rho_{CI} = \delta(A_G + A_I + A_P)$. Figure 24 shows the results of utilizing the opportunistic and idealistic recruitment functions compared to the initial recruitment function ($\rho_{CI} = \delta(A_G + A_P - A_I)$) and a recruitment function where the coercive efforts of the insurgency are counter effective, $\rho_{CI} = \delta(A_G + A_{PG} - A_I - A_{PI})$. We can see from the results in Figure 24 that the idealistic and opportunistic recruitment functions both have similar insurgency growth to the initial recruitment function $\rho_{CI} = \delta(A_G + A_P - A_I)$ but affect the time at which this growth occurs. The fourth function, where the coercive efforts of the insurgency are ineffective, has a very different result. As in the improved concave intelligence parameter (Figure 20), a change in the blame associated with coercive population attrition has a strong impact on the outcome of the model (the thick line in Figure 24). In the advanced model run the scaling factors δ and ε are a constant set to 250. (The population transition parameter has been reset to its initial value of $\rho_{SC} = A_I - A_G - A_P$). (Once again, for Figures 24 and 25, note the change in the Y-axis).

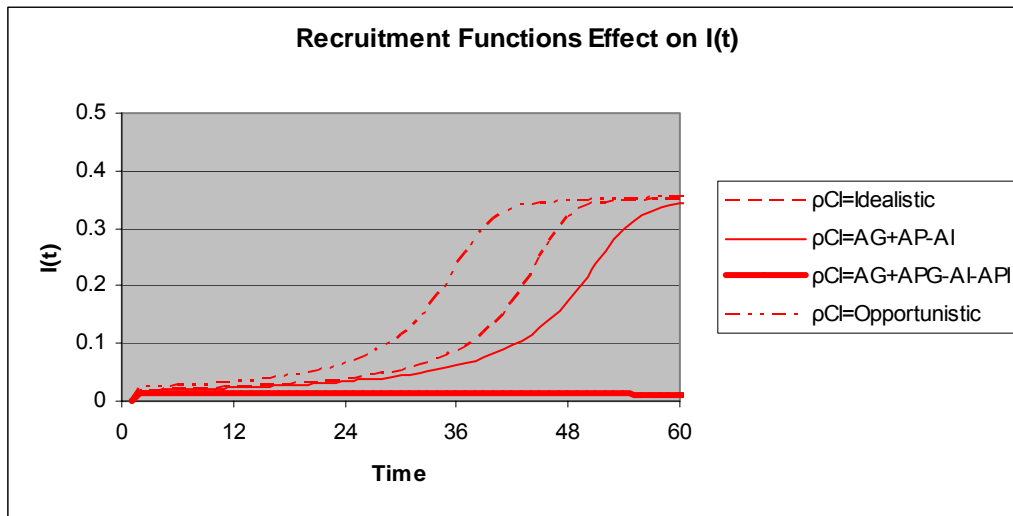

Figure 24. Recruitment Functions Effect On $I(t)$ in Advanced Model

The government effort parameter γ is a policy or decision parameter that is based on how the government is fundamentally going to react to insurgency violence and

violence against the population (both insurgency and government inflicted). Up to this point the government effort against the insurgency has been constant (in the basic model) or a linear function of the violence committed against the government and the population by the insurgency and the collateral damage caused to the population by the government. Another possible function could be a direct reaction to the violence directed against the government: $\gamma \approx A_G$. This policy ignores an important aspect of the government's primary responsibilities: the protection of the population. We can modify the government effort by taking into account a reaction to violence against the population: $\gamma \approx A_G + A_{PI}$. Figure 25 shows the results of implementing these functions in the advanced model. (The recruitment parameter has been reset to the initial value of $\rho_{CI} = \delta(A_G + A_P - A_I)$).

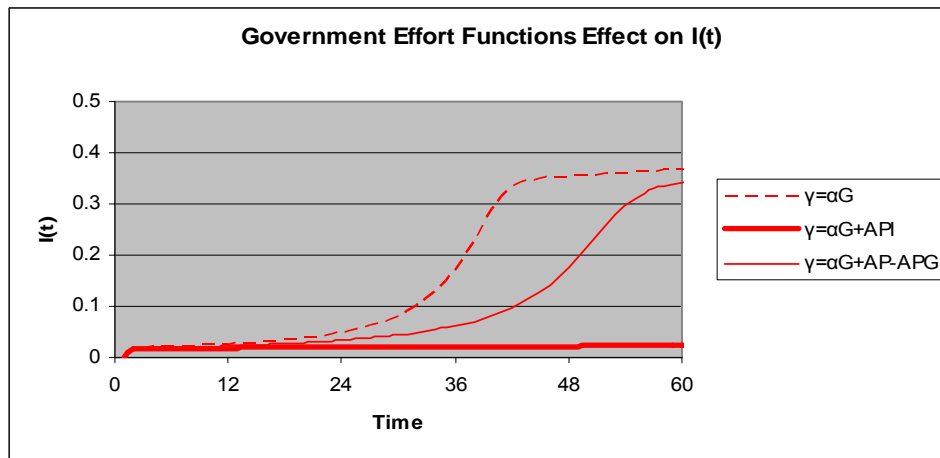

Figure 25. Government γ Functions Effect On $I(t)$ in Advanced Model

Unsurprisingly, if the government can ignore the collateral damage they cause they can attack the insurgency most effectively (thick line at the bottom of Figure 25). It is interesting to note that the government receives positive results from protecting the population and avoiding collateral damage (thin solid line in Figure 25) versus a simple direct reaction to the amount of violence the insurgency directs against the government (the dashed line in Figure 25).

Our primary results of comparing both the basic model and the advanced model are that the insurgency grows at a greater initial rate in the advanced model but that both models experience slowing of growth due to their diminishing pool of contrarian recruits. The change in the intelligence parameter functioned in the same way in both models: a concave function improved government efforts against the insurgency while a convex function hurt these efforts (Figures 11 and 20). A change in the population parameter to hold the insurgency responsible for insurgency attrition against the population also had a similar effect in both models as demonstrated in Figures 13 and 22. In the advanced model we could expand the analysis of the basic model by examining variable insurgency recruitment and government effort. Figures 24 shows the results of simple recruitment policy decisions by the insurgency and Figure 25 shows the results of simple government policy decisions on how to attack the insurgency. These decisions can have a strong impact on the outcome of the conflict: a defeated insurgency when coercive violence is not effective ($\rho_{CI} = \delta(A_G + A_{PG} - A_I - A_{PI})$) and when the government can ignore collateral damage to the population ($\gamma \approx A_G + A_{PI}$).

D. FINAL NOTES

Analyzing basic OIF casualty and force data allowed us to determine some realistic initial conditions for the insurgency and population models. An argument could be made that a better measure of the effort of the insurgency against both the government and the population would be the number attacks attempted by the insurgency. Clearly the military forces are better able to protect themselves and have only increased these abilities as the conflict has gone on. According to Major General Webster of the coalition forces, the number of successful attacks against the coalition and Iraqi forces dropped to about 10% in the summer of 2005 from a high of 25% - 30% in the summer of 2004. (O'Hanlon & Campbell, 2007) Our argument is that the number of casualties endured by an entity is the actual driving force behind their actions and not the number of attacks received.

THIS PAGE INTENTIONALLY LEFT BLANK

V. CONCLUSIONS

A. RESULTS

In this thesis we have explored the idea that conventional attrition models and epidemic population models can be combined to form new unconventional warfare models.

In Chapter III we developed this model based on Lanchester-type difference equations and epidemiological models based on the flow of information and ideas in a population.

In Chapter IV we analyzed the insurgency model based on a host of initial starting conditions and different parameter functions. We started with a base model and quickly moved on to a more advanced model with more interesting interactions between the attrition and the popular support. Comparing these two implementations we observe that the advanced model allowed for faster insurgency growth over the first 60 months but that both models suffer a slowing of insurgency growth due to a shrinking recruitment pool of contrarians. The advanced model also allows us to examine some simple changes in policy in insurgency recruitment and government efforts against the insurgency

The most important result from our work is that there is some utility in utilizing epidemic population models in asymmetric warfare to attempt to model population support for contending factions. The framework developed here may be utilized to study past and present insurgencies in order to gain insight into the importance of the popular will in these types of conflicts.

Operationally the most significant observation is that the contest between the insurgency and the government is not predetermined: the decisions and actions of the government and/or the insurgency determine the outcome of the conflict. Our insurgency model demonstrates this fact.

B. FUTURE RESEARCH

In our opinion this thesis contains many possibilities for applied mathematics and combat modeling. Many subtleties of the attrition-population model interaction have been left unexplored. A natural continuation of this work could include the following:

1. Expanding the state space of the population to include neutrals, semi-fanatic, and other possible population sub-classes. (Castillo-Chavez & Song, 2004)

2. Expanding the population transition parameter to multiple parameters based on a variety of soft government and insurgent efforts: Civil Affairs, Psychological Operations, etc.

3. A much more in depth study of how government intelligence can be modeled and if it is directly related to popular support for the government.

4. A more in depth study of the best way to model insurgency recruitment: coercive violence versus other recruitment policies.

5. A more extensive and detailed examination of different insurgency and government policies and decisions and how they affect the model including historical policies and decision and how they possibly fit into the model.

6. An examination of other historical insurgency data. In particular the Malayan Emergency, Vietnam and the recent conflicts between Israel and the PLO/Lebanon would seem to lend themselves to this analysis as they are well documented with a lot of accurate data.

APPENDIX A. OPERATION IRAQI FREEDOM DATA

Below is the Operation Iraqi Freedom (OIF) Coalition, Iraqi Government, Iraqi civilian population and insurgency force levels and casualty data.

US and Coalition, Iraqi Government, and Civilian Force Levels and Casualties by month:

Date	US & Coalition Forces (Total)	Iraqi Forces (Total)	Govt Forces (Total)	Govt Losses (Total)	Civilian Casualties	Insurgent Attacks Against Coalition	Insurgent Attacks Against Civilians
Mar-03	0	0	0	65	6,415		
Apr-03	0	0	0	74	1,030		
May-03	173,000	9,000	182,000	37	463	200	0
Jun-03	171,000	15,000	186,000	98	570	400	0
Jul-03	170,000	30,000	200,000	116	591	600	0
Aug-03	161,000	37,170	198,170	103	741	600	50
Sep-03	156,000	44,200	200,200	99	504	700	50
Oct-03	156,000	66,800	222,800	112	452	900	100
Nov-03	146,900	94,800	241,700	150	415	900	150
Dec-03	146,500	100,100	246,600	108	486	650	100
Jan-04	147,600	108,800	256,400	115	525	600	150
Feb-04	139,000	125,000	264,000	88	536	650	150
Mar-04	154,000	134,991	288,991	120	916	800	100
Apr-04	162,000	124,253	286,253	203	1,182	1,600	150
May-04	162,000	135,712	297,712	148	574	1,650	150
Jun-04	161,000	145,317	306,317	110	795	1,400	250
Jul-04	162,000	95,088	257,088	122	710	1,500	250
Aug-04	163,700	91,468	255,168	134	775	2,700	300
Sep-04	162,600	98,708	261,308	148	859	1,800	200
Oct-04	162,000	110,998	272,998	131	859	2,000	400
Nov-04	162,000	113,506	275,506	205	1,484	2,500	400
Dec-04	173,000	122,453	295,453	140	846	1,600	350
Jan-05	175,300	125,373	300,673	216	955	2,300	500
Feb-05	180,000	141,761	321,761	161	1,167	1,400	350
Mar-05	172,000	151,911	323,911	211	659	1,300	200
Apr-05	164,000	159,493	323,493	251	894	1,500	250
May-05	161,000	168,227	329,227	339	1,138	1,700	300
Jun-05	158,000	168,854	326,854	374	1,152	1,550	350
Jul-05	161,000	173,900	334,900	358	1,357	2,000	400
Aug-05	161,000	182,900	343,900	367	2,089	2,100	500
Sep-05	160,000	192,100	352,100	282	1,198	2,100	400
Oct-05	174,000	211,000	385,000	311	1,083	2,600	450

Nov-05	183,000	214,000	397,000	260	1,169	1,600	350
Dec-05	183,000	223,700	406,700	261	915	2,000	500
Jan-06	157,000	227,300	384,300	251	1,265	1,700	350
Feb-06	153,000	232,100	385,100	213	1,262	1,750	600
Mar-06	153,000	250,500	403,500	224	1,538	2,200	600
Apr-06	152,000	253,700	405,700	277	1,290	2,600	650
May-06	152,000	263,400	415,400	218	1,809	2,850	700
Jun-06	146,900	264,600	411,500	189	2,053	2,800	700
Jul-06	149,000	269,600	418,600	266	3,033	3,400	800
Aug-06	157,000	298,000	455,000	296	2,676	3,300	800
Sep-06	162,000	307,800	469,800	220	2,208	3,900	900
Oct-06	161,200	312,400	473,600	328	2,781	4,350	1,100
Nov-06	158,000	323,000	481,000	191	2,833	3,650	900
Dec-06	155,200	323,000	478,200	232	2,419	3,900	1,000
Jan-07	146,650	323,180	469,830	179	2,022		
Feb-07	149,010	329,800	478,810	229	2,061		
Mar-07	155,205	334,300	489,505	299	1,169		

Insurgency Force Levels, Casualties, and US Prison Population:

Date	Insurgent Strength	Estimated Foreign Fighter Strength	Total Insurgent Strength	Insurgents Detained or Killed	Estimated Insurgent KIA*	US Prison Population
May-03	3500		3,500	1,000	120	
Jun-03	3500		3,500	1,000	120	
Jul-03	4000		4,000	1,000	120	
Aug-03	4000		4,000	1,000	120	
Sep-03	5000		5,000	750	90	
Oct-03	5000		5,000	750	90	
Nov-03	5,000	500	5,500	3,000	360	
Dec-03	5,000	500	5,500	1,000	120	
Jan-04	5,500	500	6,000	2,500	300	
Feb-04	5,500	500	6,000	2,000	240	
Mar-04	5,500	500	6,000	1,750	210	
Apr-04	5,500	500	6,000	2,000	240	
May-04	15,500	500	16,000	2,000	240	
Jun-04	15,500	500	16,000	1,220	146	5,435
Jul-04	20,500	500	21,000	1,000	120	5,700
Aug-04	20,500	500	21,000	2,500	300	
Sep-04	20,500	500	21,000	2,500	300	5,500
Oct-04	20,500	500	21,000	2,000	240	4,300
Nov-04	20,500	500	21,000	3,000	360	8,300
Dec-04	20,500	500	21,000	2,000	240	
Jan-05	18,500	500	19,000	2,500	300	7,837
Feb-05	18,500	500	19,000	1,000	120	
Mar-05	16,500	1,000	17,500	1,000	120	

Apr-05	16,500	1,000	17,500	1,000	120	
May-05	17,000	1,000	18,000	2,000	240	
Jun-05	21,000	1,000	22,000	2,000	240	10,783
Jul-05	21,000	2,000	23,000	2,000	240	15,000
Aug-05	21,000	2,000	23,000	3,000	360	14,000
Sep-05	22,000	2,000	24,000	3,000	360	14,000
Oct-05	22,000	2,000	24,000	2,000	240	13,000
Nov-05	22,000	2,000	24,000	2,000	240	13,000
Dec-05	22,000	2,000	24000	2,000	240	14,000
Jan-06	22,000	2,000	24,000	2,000	240	14,000
Feb-06	22,000	2,000	24,000	2,000	240	14,767
Mar-06	22,000	2,000	24,000	2,000	240	15,000
Apr-06	22,000	2,000	24,000	2,000	240	15,000
May-06	22,000	2,000	24,000	1,000	240	15,000
Jun-06	22,000	2,000	24,000	1,000	240	14,500
Jul-06	22,000	2,000	24,000	1,000	240	13,000
Aug-06	22,000	2,000	24,000	1,000	240	13,000
Sep-06	22,000	2,000	24,000	750	240	13,000
Oct-06	30,000	2,000	32,000	750	241	13,000
Nov-06	30,000	2,000	32,000	3,000	241	13,000
Dec-06	30,000	2,000	32,000	1,000	241	13,000
Jan-07	30,000	2,000	32,000	2,500	241	14,000
Feb-07	30,000	2,000	32,000	2,000	241	15,000
Mar-07	70,000	2,000	72,000	1,750	241	17,000

THIS PAGE INTENTIONALLY LEFT BLANK

LIST OF REFERENCES

- Belen, S., & Pearce, C. E. M. (2004). Rumours with general initial conditions. *The ANZIAM Journal; the Australian and New Zealand Industrial and Applied Mathematics Journal*, 45, 393-400.
- Bettencourt, L., Cintron-Arias, A., Kaiser, D., & Castillo-Chavez, C. (2006). The power of a good idea: Quantitative modeling of the spread of ideas from epidemiological models. *Physica A: Statistical Mechanics and its Applications*, 364(15 May), 513-536.
- Cable, L. E. (1986). *Conflict of Myths. The Development of American Counterinsurgency Doctrine and the Vietnam War*. London and New York: New York University Press
- Castillo-Chavez, C. & Song, B. (2004). Models for the Transmission Dynamics of Fanatic Behaviors. 155-171
- Daley, D. J., & Kendall, D. G. (1964). Stochastic Rumours. *Journal of the Institute of Mathematical Applications*, 1(1), 42-55.
- Dardagan, H. (2007). The Iraq Body Count Database. *Iraq Body Count*. Retrieved 17 April 2007, from <http://www.iraqbodycount.net/>
- Deitchman, S.J. (1962). A Lanchester Model of Guerrilla Warfare. *INFORMS*, 818-827.
- Hammes, T. X. (2006). Countering Evolved Insurgent Networks. *Military Review*, July-August 18-25.
- Headquarters, Department of the Army. (2006). *Army Field Manual 3-24: Counterinsurgency*. Washington, DC: Government Printing Office.
- Hoffman, B. (2004). *Insurgency and Counterinsurgency in Iraq*. Santa Monica, CA: RAND
- Kaplan, E. H., & Jacobson, D. (2006). Suicide Bombings and Targeted Killings in (Counter) Terror Games JCR, 1-48
- Karadsheh, J. (2006). *Study: War Blamed for 655,000 Iraqi Deaths*. CNN.com. Retrieved 17 Apr, 2007 from <http://www.cnn.com/2006/WORLD/meast/10/11/iraq.deaths/>
- Kilcullen, D. (2006). "Twenty-Eight Articles": Fundamentals of Company-level Counterinsurgency. *Military Review*, May-June, 103-108.

- Komer, R. W. (1972). *The Malayan Emergency in Retrospect: Organization of a Successful Counterinsurgency Effort*. Santa Monica, CA: The Rand Corporation.
- Kress, M. (2006). Policies for biodefense revisited: The prioritized vaccination process for smallpox. *Ann Oper Res* 148, August 22, 5-23
- Lanchester, F. W. (1916). *Aircraft in Warfare: The Dawn of the Fourth Arm*. London: Constable.
- Leites, N. & Wolf, C. (1970). *Rebellion and Authority: An Analytical Essay on Insurgent Conflicts*. The Rand Corporation. Chicago: Markham Publishing Company.
- Lynn, J. A. (2005). Patterns of Insurgency and Counterinsurgency. *Military Review*, July-August 22-27.
- McCormick, G. H. & Giordano, F. R. (2002). The Dynamics of Insurgency. *Operations Research*, January-February, 302-331.
- O'Hanlon, M., E. & Campbell, J., H. (2007). Iraqi Index. Tracking Variables of Reconstruction and Security in Post-Saddam Iraq. (April 30) *The Brookings Institution*. Retrieved 25 May 2007, from <http://www.brookings.edu/fp/saban/iraq/indexarchive.htm>
- O'Neill, B. E. (2005). *Insurgency and Terrorism* (2nd ed.). Washington D.C.: Potomac Books
- Schaffer, M. B. (1968). Lanchester Models of Guerrilla Engagements. *Operations Research*, May-June, 457-488.
- Schramm, H. C. (2006). *An Analytical Framework for the War of Ideas*. M.S. Thesis, Naval Postgraduate School, California, September.
- White, M. (2007). Military Fatalities: By Month. *Iraq Coalition Casualty Count*. Retrieved 17 April 2007, from <http://icasualties.org/oif/IraqiDeaths.aspx>

INITIAL DISTRIBUTION LIST

1. Defense Technical Information Center
Ft. Belvoir, Virginia
2. Dudley Knox Library
Naval Postgraduate School
Monterey, California
3. Professor Moshe Kress
Naval Postgraduate School
Operations Research Department
Monterey, California
4. Colonel Alejandro Hernandez
Naval Postgraduate School
Operations Research Department
Monterey, California
5. Lieutenant Colonel Reb Yancey
SOCOM
SORR-J8-Studies
MacDill, AFB Florida