



**Calhoun: The NPS Institutional Archive**

---

Theses and Dissertations

Thesis Collection

---

2007-09

Optimum antenna configuration for maximizing access point range of an IEEE 802.11 wireless mesh network in support of multi-mission operations relative to hastily formed scalable deployments

Lounsbury, Robert Lee.

Monterey California Naval Postgraduate School



Calhoun is a project of the Dudley Knox Library at NPS, furthering the precepts and goals of open government and government transparency. All information contained herein has been approved for release by the NPS Public Affairs Officer.

**Dudley Knox Library / Naval Postgraduate School  
411 Dyer Road / 1 University Circle  
Monterey, California USA 93943**

<http://www.nps.edu/library>



**NAVAL  
POSTGRADUATE  
SCHOOL**

**MONTEREY, CALIFORNIA**

**THESIS**

**OPTIMUM ANTENNA CONFIGURATION FOR MAXIMIZING  
ACCESS POINT RANGE OF AN IEEE 802.11  
WIRELESS MESH NETWORK IN SUPPORT OF MULTI-  
MISSION OPERATIONS RELATIVE TO HASTILY  
FORMED SCALABLE DEPLOYMENTS**

by

Robert Lee Lounsbury, Jr.

September 2007

Thesis Advisor:  
Second Reader:

James Ehlert  
Karl Pfeiffer

**Approved for public release; distribution is unlimited**

THIS PAGE INTENTIONALLY LEFT BLANK

REPORT DOCUMENTATION PAGE			Form Approved OMB No. 0704-0188	
Public reporting burden for this collection of information is estimated to average 1 hour per response, including the time for reviewing instruction, searching existing data sources, gathering and maintaining the data needed, and completing and reviewing the collection of information. Send comments regarding this burden estimate or any other aspect of this collection of information, including suggestions for reducing this burden, to Washington headquarters Services, Directorate for Information Operations and Reports, 1215 Jefferson Davis Highway, Suite 1204, Arlington, VA 22202-4302, and to the Office of Management and Budget, Paperwork Reduction Project (0704-0188) Washington DC 20503.				
1. AGENCY USE ONLY (Leave blank)		2. REPORT DATE September 2007	3. REPORT TYPE AND DATES COVERED Master's Thesis	
4. TITLE AND SUBTITLE Optimum Antenna Configuration for Maximizing Access Point Range of an IEEE 802.11 Wireless Mesh Network in Support of Multi-mission Operations Relative to Hastily Formed Scalable Deployments			5. FUNDING NUMBERS	
6. AUTHOR(S) Robert Lee Lounsbury, Jr.				
7. PERFORMING ORGANIZATION NAME(S) AND ADDRESS(ES) Naval Postgraduate School Monterey, CA 93943-5000			8. PERFORMING ORGANIZATION REPORT NUMBER	
9. SPONSORING/MONITORING AGENCY NAME(S) AND ADDRESS(ES) Space and Naval Warfare Systems Center San Diego, CA			10. SPONSORING/MONITORING AGENCY REPORT NUMBER	
11. SUPPLEMENTARY NOTES The views expressed in this thesis are those of the author and do not reflect the official policy or position of the Department of Defense or the U.S. Government.				
12a. DISTRIBUTION / AVAILABILITY STATEMENT Approved for public release; distribution is unlimited			12b. DISTRIBUTION CODE	
13. ABSTRACT (maximum 200 words) To secure a nation, a border, or physical entity, a robust communications system is paramount. Fused, real-time voice, video, and sensor data are enablers in this effort. Building a system that can deliver all of these, with actionable merit, is perhaps the greatest challenge we face in this arena today. The Cooperative Operations & Applied Science and Technology Studies (COASTS) international field experimentation program at the naval Postgraduate School (NPS) aims to meet this challenge head-on, building a system of systems with technologies available now. A large part of the enabling network for COASTS is an IEEE 802.11 wireless mesh, deployed on the ground, on the sea, and in the air. This thesis tests and evaluates various antenna configurations, using the latest equipment available, building on lessons learned from the COASTS 2005 field experiment. Data is then used to determine the optimum design which allows the greatest range and throughput for the COASTS 2006 topology. Input from NPS advisors, COASTS commercial partners, including Mesh Dynamics, Mercury Data Systems, and the Air Force Force Protection Battelab, along with extensive testing of available antennas over multiple field experiments, culminates in the successful field testing of the 802.11 network topology. The final configuration provides an impressive and highly reliable aerial and ground based access point range and throughput for the network.				
14. SUBJECT TERMS Wireless LAN, IEEE 802.11, Lighter Than Air Vehicles, Aerial C2, Aerial Payload, Antenna Configuration, Multi-polarized Antenna, Mesh Network			15. NUMBER OF PAGES 113	
			16. PRICE CODE	
17. SECURITY CLASSIFICATION OF REPORT Unclassified	18. SECURITY CLASSIFICATION OF THIS PAGE Unclassified	19. SECURITY CLASSIFICATION OF ABSTRACT Unclassified	20. LIMITATION OF ABSTRACT UU	

THIS PAGE INTENTIONALLY LEFT BLANK

Approved for public release; distribution is unlimited

OPTIMUM ANTENNA CONFIGURATION FOR MAXIMIZING ACCESS POINT  
RANGE OF AN IEEE 802.11 WIRELESS MESH NETWORK IN SUPPORT OF  
MULTI-MISSION OPERATIONS RELATIVE TO HASTILY FORMED  
SCALABLE DEPLOYMENTS

Robert L. Lounsbury, Jr.  
Captain, United States Air Force  
B.S., University of Maryland University College, 2002

Submitted in partial fulfillment of the  
requirements for the degree of

MASTER OF SCIENCE IN SYSTEMS TECHNOLOGY  
(Command, Control, and Communications (C3))

from the

NAVAL POSTGRADUATE SCHOOL  
September 2007

Author: Robert Lee Lounsbury, Jr.

Approved by: James Ehlert  
Thesis Advisor

Karl Pfeiffer  
Second Reader

Dan C. Boger, PhD  
Chairman, Department of Information Sciences

THIS PAGE INTENTIONALLY LEFT BLANK

## ABSTRACT

To secure a nation, a border, or physical entity, a robust communications system is paramount. Fused, real-time voice, video, and sensor data are enablers in this effort. Building a system that can deliver all of these, with actionable merit, is perhaps the greatest challenge we face in this arena today. The Cooperative Operations & Applied Science and Technology Studies (COASTS) international field experimentation program at the Naval Postgraduate School (NPS) aims to meet this challenge head-on, building a system of systems with technologies available now.

A large part of the enabling network for COASTS is an IEEE 802.11 wireless mesh, deployed on the ground, on the sea, and in the air. This thesis tests and evaluates various antenna configurations, using the latest equipment available, building on lessons learned from the COASTS 2005 field experiment. Data is then used to determine the optimum design which allows the greatest range and throughput for the COASTS 2006 topology.

Input from NPS advisors, COASTS commercial partners, including Mesh Dynamics, Mercury Data Systems, and the Air Force Force Protection Battlelab, along with extensive testing of available antennas over multiple field experiments, culminates in the successful field testing of the 802.11 network topology. The final configuration provides an impressive and highly reliable aerial and ground based access point range and throughput for the network.



THIS PAGE INTENTIONALLY LEFT BLANK

## TABLE OF CONTENTS

I.	INTRODUCTION .....	1
A.	OBJECTIVE .....	1
B.	SCOPE .....	2
C.	RESEARCH QUESTION .....	2
D.	SECONDARY QUESTIONS .....	3
E.	OUTLINE .....	3
F.	CHAPTER ORGANIZATION .....	4
II.	COASTS BACKGROUND .....	7
A.	COASTS OVERVIEW .....	7
B.	COASTS 2005 .....	10
1.	Network Topology .....	10
2.	Balloon .....	12
3.	Aerial Payloads .....	13
4.	Aerial Node Lessons Learned .....	14
a.	<i>Balloon Lessons Learned</i> .....	15
b.	<i>Payload Lessons Learned</i> .....	16
C.	COASTS 2006 AERIAL PAYLOAD SOLUTION .....	19
1.	Equipment .....	19
2.	Design .....	21
3.	Initial Implementation Results .....	29
III.	THE TACTICAL IEEE 802.11 NETWORK .....	31
A.	COASTS 2005 IEEE 802.11 NETWORK .....	31
1.	Equipment .....	31
2.	COASTS 2005 IEEE 802.11 Lessons Learned .....	33
B.	COASTS 2006 IEEE 802.11 NETWORK .....	38
1.	Topology .....	38
2.	Equipment .....	39
IV.	COASTS 2006 FIELD EXPERIMENTS .....	43
A.	BACKGROUND .....	43
B.	PRE THAILAND FIELD EXPERIMENTS .....	44
1.	Method .....	44
2.	Physical Configuration of Tests .....	45
3.	Pt Sur Field Experiment .....	46
4.	Ft Ord Field Experiment .....	48
5.	Ft Hunter Ligget .....	51
a.	<i>Optimum Antenna Configuration Consideration</i> .....	54
C.	MAE NGAT DAM, CHIANG MAI, THAILAND, FIELD EXPERIMENT .....	62
1.	Method .....	65
2.	Test Results .....	65

V. CONCLUSION .....71  
A. ANTENNA TESTS .....71  
    1. Composite Analysis .....71  
    2. Anechoic Chamber .....78  
B. FUTURE WORK .....83  
LIST OF REFERENCES .....85  
APPENDIX A. POWER CABLE SCHEMATIC .....87  
APPENDIX B. ANTENNA TEST DATA .....89  
INITIAL DISTRIBUTION LIST .....91

## LIST OF FIGURES

Figure 1.	COASTS 2005 Network Topology (From Operations Order 04-05).....	11
Figure 2.	Flotograph Sky-Doc Balloon, COASTS 2005 (From Lee 20).....	12
Figure 3.	Rajant Technologies Breadcrumbs (XL, SL, ME) (From Lee 27).....	13
Figure 4.	COASTS 2005 payloads, "The Tool Box" and "The Bomb" (From Lee 28, 32).....	14
Figure 5.	COASTS 2006 Balloon.....	16
Figure 6.	COASTS 2006 IEEE 802.11 AP.....	17
Figure 7.	COASTS 2006 Antennas.....	19
Figure 8.	Ultralife UBI-2590 Battery.....	20
Figure 9.	Axis model 213 PTZ IP Camera.....	20
Figure 10.	Angle aluminum design diagram.....	22
Figure 11.	Angle Aluminum and Bolts.....	22
Figure 12.	Sling with battery attached.....	23
Figure 13.	Fastening brackets on the MD AP.....	23
Figure 14.	COASTS 2006 Payload attached to balloon.....	23
Figure 15.	COASTS 2006 Payload with sling and battery attached.....	24
Figure 16.	Tying the battery.....	25
Figure 17.	UBI-2590 Battery secured on sling.....	25
Figure 18.	Securing sling on brackets.....	26
Figure 19.	Camera bracket diagram.....	26
Figure 20.	Camera bracket, bolt, and nut.....	27
Figure 21.	Installing the camera bracket.....	27
Figure 22.	Axis 213 camera installation.....	27
Figure 23.	Cable installation.....	28
Figure 24.	Completely assembled payload with camera.....	28
Figure 25.	Payload attached to the balloon.....	29
Figure 26.	Payload in 14-17 Knot Winds at Pt Sur I.....	30
Figure 27.	COASTS 2005 Network Topology (From Operations Order 04-05 22).....	31
Figure 28.	COASTS 2005 Antennas (From Lee 38).....	32
Figure 29.	COASTS 2006 Network Topology (From CONOPS 2006 4).....	38
Figure 30.	COASTS 2006 802.11 Network Topology Mae Ngat Dam, Chiang Mai, Thailand.....	39
Figure 31.	View of COASTS 2006 802.11 Topology.....	39
Figure 32.	Mesh Dynamics Multi-radio Structured Mesh Network Access Point.....	40
Figure 33.	Backhaul Antennas Tested at Pt Sur.....	47
Figure 34.	Test Setup at Ft Ord.....	50

Figure 35.	Topology at Ft Hunter Liggett.....	53
Figure 36.	Aerial Payload and Antennas (Left Hyperlink Tech HG2408P 8dBi; Right SuperPass SPFPG9-V100 7dBi used on Balloon 1 in Figure 35 (From Superpass)).....	54
Figure 37.	RF Link Budget Calculator (From Afar Communications, Inc.).....	56
Figure 38.	Comparison of 8dBi and 12dBi Antenna Throughputs in the IEEE 802.11a Standard.....	58
Figure 39.	WiFi-Plus MP 5dBi (left) and 13dBi MP Sector Antennas (From WiFi-Plus).....	59
Figure 40.	WiFi-Plus 13dBi MP Single Sector Azimuth Coordinate Pattern (From "MP-Tech. 'Single Sector' Antenna WFP0200508 120 Degrees Coverage.").....	60
Figure 41.	WiFi-Plus 13dBi MP Single Sector Elevation Coordinate Pattern (From "MP-Tech. 'Single Sector' Antenna WFP0200508 120 Degrees Coverage.").....	60
Figure 42.	WiFi-Plus MP-Tech. 5dBi Omni Elevation Coordination Pattern Plot (From WiFi-Plus).....	61
Figure 43.	COASTS 2006 Proposed Topology Coverage Requirements (Background From Google Earth).....	62
Figure 44.	Mae Ngat Dam, Chiang Mai, Thailand (From Google Earth).....	63
Figure 45.	Mae Ngat Dam and Chiang Mai (From Google Earth).....	63
Figure 46.	Mae Ngat Dam area (From Google Earth).....	64
Figure 47.	Mae Ngat Dam Test Distances (After Google Earth).....	64
Figure 48.	Panoramic View of Mae Ngat Dam site.....	64
Figure 49.	Test Setup, COASTS 2006, Mae Ngat Dam, Thailand.....	65
Figure 50.	Multi-Polar Antenna Tests in the 802.11a Standard, Mae Ngat Dam.....	66
Figure 51.	Multi-Polar Antenna Tests in the 802.11g Standard, Mae Ngat Dam.....	67
Figure 52.	Comparison of Average Throughput for 5dBi Multi-Polar Antennas.....	68
Figure 53.	Comparison of Average Throughput for 13dBi Multi-Polar Antennas.....	68
Figure 54.	Mesh Dynamics Network Viewer Application March 27, 2006, Tethered Balloon at 1500' and 11Mbps..	74
Figure 55.	Aerial Payload as Deployed in the COASTS 2006 Field Experiment.....	74

Figure 56.	Root Node, Thailand Field Experiment COASTS 2006.....	75
Figure 57.	WiFi-Plus MP Tech 5dBi Antenna in the Naval Postgraduate School Anechoic Chamber.....	78
Figure 58.	WiFi-Plus MP Tech 5dBi, H-Plane at 2.4GHz.....	79
Figure 59.	WiFi-Plus MP Tech 5dBi, E-Plane at 2.4GHz.....	79
Figure 60.	WiFi-Plus MP Tech 5dBi, H-Plane at 5.8GHz.....	80
Figure 61.	WiFi-Plus MP Tech 5dBi, E-Plane at 5.8GHz.....	80
Figure 62.	WiFi-Plus MP Tech 13dBi Single Sector, H-Plane at 2.4GHz.....	81
Figure 63.	WiFi-Plus MP Tech 13dBi Single Sector, E-Plane at 2.4GHz.....	81
Figure 64.	WiFi-Plus MP Tech 13dBi Single Sector, H-Plane at 5.8GHz.....	82
Figure 65.	WiFi-Plus MP Tech 13dBi Single Sector, E-Plane at 5.8GHz.....	82

THIS PAGE INTENTIONALLY LEFT BLANK

## LIST OF TABLES

Table 1.	Initial COASTS 2006 FX Mesh Dynamics Access Point Configurations.....	41
Table 2.	Mesh Dynamics Access Point Model Number Breakdown.....	41
Table 3.	60% Fresnel Zone Calculation.....	45
Table 4.	Specifications of Backhaul Antennas Tested at Pt Sur (Hyperlink Technologies, SuperPass).....	47
Table 5.	Average Throughput 12dBi to 12dBi, Pt Sur.....	48
Table 6.	Average Throughput 12dBi to 8dBi, Pt Sur.....	48
Table 7.	Average Throughput 12dBi to 12dBi, Ft Ord.....	50
Table 8.	Average Throughput New Firmware 12dBi, Ft Ord...	51
Table 9.	Average Throughput 8dBi to 8dBi, Ft Hunter Liggett.....	52
Table 10.	Average Throughput 8dBi to 8dBi, Ft Hunter Liggett.....	53
Table 11.	Antennas used in Aerial IEEE 802.11g Nodes, Ft Hunter Liggett (No throughput testing performed).....	54
Table 12.	RF Link Budget Estimation at the Upper and Lower Channels of the IEEE 802.11a and IEEE 802.11g Specifications (Using Ubiquity Networks SuperRange5 and SuperRange2 Radio specifications).....	57
Table 13.	WiFi-Plus MP 5dBi and 13dBi MP Sector Antenna Specifications (After WiFi-Plus).....	61
Table 14.	Antenna Test Throughput Comparison (Maximum Throughput Indicated by Green Highlights).....	71
Table 15.	Antenna Test Throughput Comparison Excludes 13dBi to 13dBi Tests (Maximum Throughput Indicated by Green Highlights).....	72
Table 16.	Thailand Test IV 13dBi to 5dBi Signal Strength and Average Throughput.....	73
Table 17.	Thailand Field Experiment Node Details as Deployed.....	76
Table 18.	Recommended Network Implementation Thailand Demonstration, May 2006.....	77



THIS PAGE INTENTIONALLY LEFT BLANK

## LIST OF ACRONYMS AND ABBREVIATIONS

ACK	Acknowledgement
AOR	Area of Responsibility
AP	Access Point
C2	Command and Control
Cat	Category
COASTS	Coalition Operating Area Surveillance and Targeting system
COC	Command Operations Center
COTS	Commercial-off-the-shelf
CRADA	Cooperative Research and Development Agreement
DRDO	Department of Research and Development Office, Thailand
HFN	Hastily Formed Network
IEEE	Institute of Electrical and Electronic Engineers
IP	Internet Protocol
JIATF-W	Joint Interagency Task Force West
JUSMAGTHAI	Joint U.S. Military Advisory Group Thailand
LOS	Line of Sight
MCP	Mobile Command Post
MDS	Mercury Data Systems
NMEA	National Marine Electronics Association
NMS	Network Management System
NPS	Naval Postgraduate School
NPSSOCFEP	Naval Postgraduate School U.S. Special Operations Command Field Experimentation Program
PoE	Power over Ethernet
PTZ	Pan, Tilt, Zoom
RF	Radio Frquency
RTAF	Royal Thai Air Force
RTARF	Royal Thai Armed Forces
SOF	Special Operations Forces
SPAWAR	Space and Naval Warfare Systems Center
USPACOM	U.S. Pacific Command
USSOCOM	U.S. Special Operations Command
WiFi	Wireless Fidelity
WiMAX	Worldwide Interoperability for Microwave Access
WLAN	Wireless Local Area Network
WMN	Wireless Mesh Network
WOT	War on Terror

THIS PAGE INTENTIONALLY LEFT BLANK

## **ACKNOWLEDGMENTS**

First, I would like to thank Mr. Ehlert for working with me to ensure my thesis would not only support COASTS needs but my interests as well. Next, a round of thanks is, of course, in order to my fellow COASTS team members (Joe, Scott, Red, Mike, Ho, Jon and the rest of the crew). A special thanks to Swampy for those deep, calming, COMMS which were many times necessary. Lest I forget, an ode to the confessional - Joe, you know what I'm talking about. Finally, my wife for enduring my frustrations and the many weekends/weeks I spent away from home while helping to keep the COASTS train rolling.

THIS PAGE INTENTIONALLY LEFT BLANK

## I. INTRODUCTION

### A. OBJECTIVE

Using today's communication and networking technologies to provide actionable data over varying and demanding terrains to battlefield warriors, while providing situational awareness to higher echelon commands, is a great challenge. The ability to tactically capture a vast range of ubiquitous sensor information, such as video, voice and unmanned system data, currently exists. However, the communication mediums over which this data may be transported in real-time are perhaps the single largest shortfall which limits war-fighter effectiveness.

The widely implemented Institute of Electrical and Electronic Engineers (IEEE) 802.11 communications standard is the Cooperative Operations & Applied Science and Technology Studies (COASTS) international field experiment's standard of choice for deployment of hastily formed networks. Through the use of robust, multiple radio access points, COASTS employs an IEEE 802.11 wireless mesh network (WMN) fusing real-time voice, video, data, and positional information across the area of operations (AOR) which are then transferred over IEEE 802.16 Worldwide Interoperability for Microwave Access (WiMAX) and satellite links to distant higher headquarters.

To successfully implement such a vision requires carefully selected components. The objective of this thesis is to determine the most effective antenna configuration which will allow the greatest access point to access point range, while maximizing backhaul link

throughput, for both the ground and aerial portions of the COASTS 2006 IEEE 802.11 network. Achieving this objective required consultation with COASTS partners and much applied science and trial and error. Using antennas available from various departments at the Naval Postgraduate School (NPS), the COASTS inventory, and COASTS commercial partners, and spanning three major field experiments, many configurations were tested, evaluated, and documented. Details of aerial payload design, aerial and ground antenna orientation and configuration, field tests, and the final antenna selection for deployment in the COASTS 2006, Mae Ngat Dam, Thailand, field experiment are provided.

## **B. SCOPE**

The thesis will detail the specifications for the structured mesh networking equipment, antennae and their physical configuration for each COASTS deployment. Line-of-sight range, terrain, altitude and weather data will be recorded. Optimum configuration will be declared when maximum range between the root and one downstream access point (AP) - one hop - is achieved. Maximum range is defined as having a reliable, acceptable throughput as measured with IXIA's IxChariot network performance software.

## **C. RESEARCH QUESTION**

What is the optimum antenna configuration that will provide the best possible range between access points while maintaining acceptable throughput and lightest footprint for a 400mw, three radio design, IEEE 802.11 backhaul mesh network?

#### **D. SECONDARY QUESTIONS**

- How can the aerial payload be built to suit rapid deployment while remaining flexible for testing various antenna configurations?
- How will various antenna types perform in air-to-air, ground-to-ground, and air-to-ground?
- What is the optimum antenna configuration for ground to ground network communications in a 400mw, three radio design, 802.11 backhaul mesh network?
- What is the optimum antenna configuration for ground to air network communications in a 400mw, three radio design, 802.11 backhaul mesh network?
- What is the optimum antenna configuration for air to air network communications in a 400mw, three radio design, 802.11 backhaul mesh network?
- What is the minimum horizontal and vertical spacing between antennae that will provide the best performance on the aerial AP?
- What is the minimum mounting height of the antennae that will provide acceptable performance?
- How well does the optimized configuration perform in terms of throughput at various points in the network?

#### **E. OUTLINE**

This thesis begins with a background discussion of the COASTS effort and its multi-mission, hastily formed nature. Then, an overview of the COASTS 2005 iteration is presented to include a look at the aerial node lessons learned and issues the team faced. The COASTS 2006 iteration's aerial payload solution is then presented in detail. Next, the IEEE 802.11 network equipment utilized in the tactical portion of the COASTS 2005 international field experiment, along with lessons learned, is reviewed. Readers are then introduced to the IEEE 802.11 mesh network equipment used in COASTS 2006, accompanied by an overview of the reasons



for having selected this equipment. Next, a chronology of the field experiments is presented which details the tested antennas and configuration decisions made along the way, as well as detailed field experiment results. Then, anechoic chamber tests are reviewed, and observations revealed. Finally, a conclusion discussing areas for improvement and future work wraps up this research.

## **F. CHAPTER ORGANIZATION**

This thesis is organized as follows:

Chapter II familiarizes the reader with the general COASTS effort. This chapter begins with an overview of the COASTS objectives and requirements, and continues with background information from the COASTS 2005 iteration, to include the balloon and aerial payload used and the two payload designs themselves. COASTS 2005 lessons learned are then reviewed and analyzed, establishing the basis for this thesis. Next, the COASTS 2006 aerial payload solution is presented. The chapter then moves on to the materials employed and assembly of the payload. The chapter ends with observations from the payload's debut at the initial field testing in March 2006.

Chapter III introduces the tactical IEEE 802.11 network. The topology, equipment used, and lessons learned from the COASTS 2005 iteration are first reviewed. Then, a look at the topology and IEEE 802.11 mesh equipment utilized in COASTS 2006 is provided. Highlights of the equipment improvements over those utilized in COASTS 2005 are also presented.

Chapter IV provides a chronology of the COASTS 2006 field experiments detailing the various antennas tested throughout this research effort. Field experiment results are examined and configuration decisions and observations made along the way are discussed and analyzed.

Finally, Chapter V summarizes the research and offers insight on areas for improvement and future work.

THIS PAGE INTENTIONALLY LEFT BLANK

## II. COASTS BACKGROUND

### A. COASTS OVERVIEW

The COASTS field experiments support a multitude of organizations including U.S. Pacific Command (USPACOM), Joint Interagency Task Force West (JIATF-W), Joint U.S. Military Advisory Group Thailand (JUSMAGTHAI), U.S. Special Operations Command (USSOCOM), NPS, Royal Thai Armed Forces (RTARF), and the Thai Department of Research & Development Office (DRDO) research requirements relating to theater and national security, counter drug and law enforcement, and the War On Terror (WOT)(COASTS CONOPS 2006 1). Interest in the IEEE 802.11 mesh network also extends to the Air Force Force Protection Battlelab, and the Air Force Unmanned Aerial Vehicle Battelab, as well as the sponsor of this thesis, Space and Naval Warfare Systems Center (SPAWAR), San Diego, CA.

Modeled after the NPS-U.S. Special Operations Command Field Experimentation Program (NPSSOCFEP), which continues to integrate the latest wireless local area network (WLAN) technologies with surveillance and targeting systems in support of USSOCOM, COASTS vectors toward areas where NPSSOCFEP does not. Limitations in NPSSOCFEP's Special Operations Forces (SOF) focused research inherently leave out foreign observers and participants. Furthermore, the relatively gentle physical environment in which NPSSOCFEP field experiments operate within, that of central California, do not lend itself to allowing data to be extrapolated to the much harsher conditions in which our

nation's military frequently operates in (COASTS CONOPS 2006 2). In a manner of speaking COASTS picks up where NPSSOCFEP leaves off.

It was once stated that to secure our own borders we must first start by securing the borders of our allies (source unknown). COASTS 2005, the first inauguration, was intended to not only provide a real-time common operating picture to the coalition command and control (C2) center but also to "demonstrate USPACOM commitment to foster stronger multi-lateral relations in the area of technology development and coalition warfare with key Pacific AOR allies in the WOT" (COASTS CONOPS 2006 2). COASTS works in partnership with the RTARF and is in discussions with other Asian countries to continue to broaden support of advancement in these technologies for the U.S. and our allies. By using exportable commercial-off-the-shelf (COTS) products and proper policy and procedures, COASTS is able to benefit from working with allied nations in this research effort. Not only does this effort work toward improved maritime and border security, it also provides the opportunity to enhance combined operations while putting today's technology through its paces in some of the harshest environments the world has to offer. Data collected in these extreme heat and humidity environments can be better applied to the range of operating environments which is essential to successful prosecution of military action in support of the War on Terror (WOT).

Specifically, the COASTS effort answers the call for low-cost, state-of-the-art, real-time threat warning and tactical communication equipment that is not only

scaleable, but also rapidly deployable to enable a tactical network virtually anywhere it is required (COASTS CONOPS 2006 7). COASTS provides an environment for NPS students and commercial vendors to rapidly deploy a hastily formed aerial and ground based WMN, typically enabling seamless communications across one square mile. This allows aerial and ground, intelligence, surveillance, and reconnaissance (ISR) data be fed across the network to a Tactical Operations Center (TOC) for local C2. Utilizing IEEE 802.16 WiMAX equipment, the WMN is connected back to a terrestrial entry point that provides data flow to regional C2 centers, higher headquarters, and anywhere else it needs to go. IEEE 802.16 Point to Multi-point (PtMP) links are also implemented at the tactical level to support high speed maritime maneuver operations enabling video surveillance and other technologies such as ground and maritime radar, chemical, biological, and radiological particle sniffers, and biometric appliances. The capstone field experiment is held in Thailand, most recently in the Chiang Mai province, at Mae Ngat Dam. The climate is hot and muggy, an environment in which electronic equipment typically does not fair well and where aerial platforms perform markedly different than in milder climates. This makes for a perfect test ground to not only test the system concept as a whole, but to also see how the COTS equipment fairs in this often brutal climate.

Clearly, this concept is not limited only to border security and maritime operations. There are many missions which could benefit from such a network. For example, in August 2005 Hurricane Katrina left the south central coast of the U.S. devastated, wiping out all forms of

communication to the region. A team of research students successfully implemented the rapidly deployable, Hastily Formed Network (HFN), concept using some of the same equipment that the COASTS 2005 field experiment employed during the months of March and May earlier in the year. The team was credited with providing the Bay St. Louis, Mississippi, hospital with Wireless Fidelity (WiFi) internet access within five hours of their arrival (Fordahl). The team continued to deploy WiFi, WiMAX, and satellite equipment creating WiFi hotspots at local fire and police stations as well as shelters and points of distribution. Through the use of the team's provided computer equipment, the connections enabled victims to communicate with loved ones and insurance companies while providing a reliable means of communication to the outside world for civilian authorities.

The proof of concept demonstrated during this humanitarian relief effort reinforces the viability and need for further research in the area of robust, easy to deploy, communications. To this end, the COASTS program continually draws on the latest technology commercial vendors have to offer to further the concept development while incorporating various additional technologies to suit the multi-mission requirements of sponsoring organizations.

## **B. COASTS 2005**

### **1. Network Topology**

The first iteration of the COASTS field experiment employed a ground and air based IEEE 802.11b WiFi network allowing tactical user connectivity and ISR data to be passed to a Mobile Command Platform (MCP) where data was

fused then passed to a Network Operations Center (NOC) at a remote location (Figure 1). To fully understand the aerial portion of the network, the individual components are introduced.

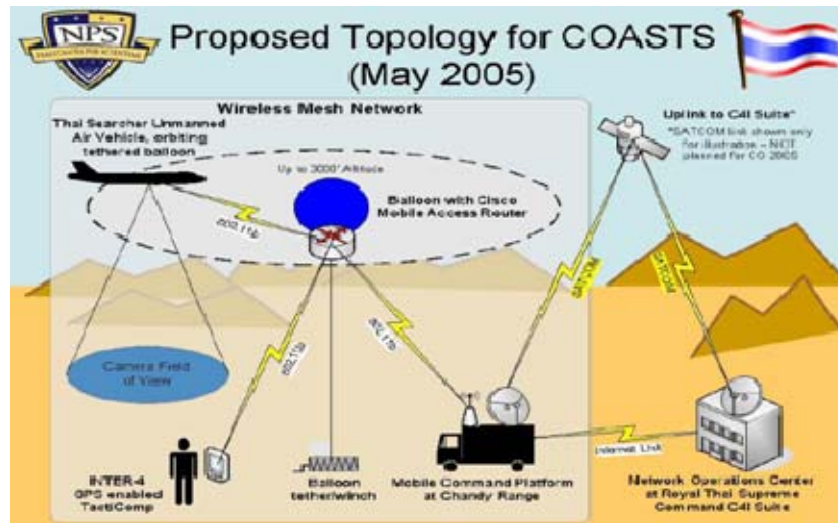

Figure 1. COASTS 2005 Network Topology  
(From Operations Order 04-05)

The aerial node of the network serves multiple purposes. Housing a pan, tilt, zoom (PTZ) camera, it first provides a higher vantage point from which to visually surveil a given area. Additionally, it houses an IEEE 802.11b WiFi AP which provides a means to relay the video surveillance as well as providing an extended line-of-sight (LOS) range improving connectivity to both tactical users and the MCP.

At the MCP, another IEEE 802.11b WiFi AP provides a link to the aerial node, wireless connections for tactical users, and a connection into the rest of the network via a router.



## 2. Balloon

The aerial node employs a tethered, helium filled, balloon. The balloon used for COASTS 2005 differs greatly from the one used for COASTS 2006. The COASTS 2005 balloon (Figure 2) was manufactured by Floatograph, the particular model was the Sky-Doc, a 13' diameter balloon with a maximum of 16.8 pounds of lift (Lee 20). As you can see in the figure, the Sky-Doc has the ability to affix a payload to two rings on the underside of the balloon.



Figure 2. Floatograph Sky-Doc Balloon, COASTS 2005  
(From Lee 20)

The Sky-Doc is also equipped with a flap, called a kite, which provides additional lift and stability, helping to keep the Sky-Doc stable in dynamic winds (Lee 20). The tether for the Sky-Doc is completely separate from the payload attachment points.

Floatograph advertised the balloon as all weather, able to operate in any environment and maintain stability in high winds however, research showed that the balloon did not perform as advertised as the balloon material

deteriorated in the tropical climate of the AOR and was therefore not selected to be employed for COASTS 2006 (Lee 16).

### 3. Aerial Payloads

The ensuing discussion is a review of the payloads used during COASTS 2005. Before discussing the design of the payloads, a brief introduction of the IEEE 802.11 equipment utilized in the payloads is in order.

Manufactured by Rajant Technologies, Breadcrumbs served as the backbone for the COASTS 2005 network topology (Figure 3). These 802.11b devices come in a variety of sizes with varying capabilities. Two of the models, the ME (Figure 3 bottom) and the XL (Figure 3 top left), were employed in the balloon payloads for COASTS 2005.



Figure 3. Rajant Technologies Breadcrumbs (XL, SL, ME) (From Lee 27)

Two payload designs were employed during COASTS 2005. The first was called the "The Tool Box" (red) and the second is referred to as "The Bomb" (yellow) (Figure 4).

"The Tool Box" was the first design employed and used a Breadcrumb ME along with an amplifier and a camera. "The Bomb" was the second payload and used a Breadcrumb XL equivalent, known as a Supercrumb, and a pan, zoom, tilt camera different from that of the first payload (not pictured). This payload was favored over "The Tool Box" for its slimmer and lighter attributes.



Figure 4. COASTS 2005 payloads, "The Tool Box" and "The Bomb" (From Lee 28, 32)

#### **4. Aerial Node Lessons Learned**

The COASTS 2005 iteration revealed several items which greatly influenced the balloon choice and payload design for COASTS 2006. Relevant lessons taken directly from LT Lee's thesis are listed below followed by a discussion of their importance. Other lessons deduced from the thesis are then introduced and their influence on the payload design reviewed.

**a. Balloon Lessons Learned**

- The extreme heat (100+ F) and intense sunlight of Lop Buri also caused some deterioration of balloon material. The valve connection lost its adhesiveness during operations which caused air to leak out of the balloon. Due to the location of the valve and unfamiliarity of proper position during operations, uncontrolled leakage of air occurred during balloon operations. (Lee 173)
- The balloon is ideally operated during moderate winds below 10 knots. This is not an all weather balloon. Extreme heat and solar conditions causes some deterioration of balloon material. Winds greater than 10 knots must be in a consistent direction. With swirling winds, the kite flap causes the balloon to twist with the changing winds and if the winds exceed 10 knots violent swirls have been observed. (Lee 174)
- For future balloon operations, it is recommended to use a simple 10 ft ball balloon. This balloon is rated with a 25 pound lift during any wind condition. The only flight pattern that should be observed is a side to side motion. With the smaller balloon, less helium is required and the cross section is much smaller. The price of the balloon is significantly less than the Sky Doc balloons (\$500.00 vice \$2000.00). (Lee 175)

The above lessons reveal the reasons a different balloon was chosen for the COASTS 2006 iteration. These reasons include material failure, wind issues due to the kite flap, and helium requirements. The COASTS 2006 balloon (Figure 5) is a standard, 10ft, helium filled, advertising balloon. This balloon has a higher advertised lift capability; however, discussion with another research

group who utilizes this balloon revealed that implementing the lightest payload design possible is desirable. This drove the simplicity of the COASTS 2006 payload design.



Figure 5. COASTS 2006 Balloon

***b. Payload Lessons Learned***

- The toolbox is not the most desirable platform to send in the air due to its broad faces and terrible aero-dynamic features. (Lee 172)
- The maximum throughput achieved was 11 Mbps for <3 minutes. Found that the Breadcrumbs are susceptible to high temperature conditions and humidity. These devices need some sort of internal fan or environmental control when used in environments such as Thailand. (Lee 172)

The lessons above indicate that the Rajant Breadcrumbs (and plastic tool boxes) are incapable of dissipating heat. Referring to Figure 3, one can observe that two of the three models are encased in plastic and that all three models are black in color. First, plastic enclosures do not

dissipate heat very well. Second, black surfaces are known to hold heat especially when placed in direct sunlight. Armed with these two facts, the lesson learned listed above, plus details from Chapter V of LT Lee's thesis (which indicate Breadcrumb failure at one hour of operation repeatedly, likely due to heat (42)), the selected COASTS 2006 IEEE 802.11 equipment varies greatly from COASTS 2005. The new equipment (introduced in detail in a later chapter) utilizes a white, aluminum enclosure, which employs an internal cooling fan (Figure 6). This unit is better able to maintain acceptable levels of internal heat. The product's monitoring application allows users to observe internal heat levels and to then state conclusively heat factors in its operation.



Figure 6. COASTS 2006 IEEE 802.11 AP

- Extreme winds and improper air pressure within the balloon caused irregular flight patterns. These extreme turns and twists caused the battery source in the payload to come in contact with the sensitive computer parts which resulted in a failure to the motherboard housing and radio

cards. After this day of experimentation, the super crumb failed to operate correctly and connectivity to the local mesh did not exist. (Lee 174)

- Maintaining a stable image from the balloon is very difficult at low altitudes. Need stability lines from the payload to the balloon tether. Simple adjustment creates significant stabilization. (Lee 173)
- A super crumb should be tested again as the payload on the balloon. A multi-polar antenna should be used for radio signals. The existing battery power is sufficient for greater than 8 hours of operation. (Lee 175)

Noting that the payload may be subject to extreme trajectories during flight, the COASTS 2006 payload was designed such that these factors would not adversely affect its survivability. This was proven and is discussed later in the chapter.

Payload stability is addressed in several ways. First, to increase aerodynamics, the COASTS 2006 payload is fashioned such that it has the smallest possible cross-sectional area. Second, additional payload stability is achieved by attaching the payload inline with the tether vice allowing it to swing freely under the balloon as did the COASTS 2005 solution. Lastly, a wind sock is fashioned on the payload such that smallest cross section of the payload heads into the wind.

Lastly, deducing from LT Chris Lee's thesis, as well as comments from the group's research advisor, Mr. James Ehlert, regarding payload movement possibly affecting connectivity, the 2006 payload solution is fastened to the balloon in a more stable manner than the COASTS 2005

payload solution. The intent was to significantly reduce the amount of sway over the previous attachment method, potentially improving connectivity. Details are provided in a later chapter.

### **C. COASTS 2006 AERIAL PAYLOAD SOLUTION**

#### **1. Equipment**

This payload solution employs the MD400 WMN AP (Figure 6). The antennas used in this payload solution are the HyperLink Technologies model HG5812U 5725 - 5850 MHz for backhaul (Figure 7 top) and the Wisp-Router model OD24-9 2400 - 2485 MHz 9dBi for service (Figure 7 bottom). Optimal antenna configuration for the aerial node is presented in a later chapter.



Figure 7. COASTS 2006 Antennas

To power the payload, an Ultralife model UBI-2590 battery is employed (Figure 8). This is the same battery employed during COASTS 2005. Performance has been acceptable and it will continue to be used for COASTS 2006. The wiring diagram for connecting the battery's cable to a Category (Cat) 5 LAN cable via Power-over-Ethernet (PoE) to the MD AP can be found in Appendix A.

The camera that will be deployed on the payload is an Axis model 213 PTZ, Internet protocol (IP) camera. Its



small size, lightweight, low cost, and ability to be controlled from anywhere on the network makes it a good choice (Figure 9).



Figure 8. Ultralife UBI-2590 Battery



Figure 9. Axis model 213 PTZ IP Camera

The balloon chosen for COASTS 2006 was introduced in Chapter II (Figure 5) and is a 10' advertising balloon with

a lift capacity of approximately 25 pounds. Applying a safety factor of two (2) drove the payload design weight to be a maximum of 14 lbs.

## **2. Design**

The design of the COASTS 2006 aerial payload is relatively simple. A more advanced design would likely be ideal for real-world implementation; however, the build was limited due to resource constraints which forced materials for the payload to be procured in a fiscally conservative manner. However, this design meets the needs of the COASTS 2006 iteration as initially demonstrated at the Pt Sur I test session. Ideas for a more robust payload design are discussed in a later chapter.

The MD AP enclosure comes with bolts to fasten it to a pole mounting bracket included in the package. Though the supplied bracket is not used in the design, the supplied bolts for the bracket are. Custom mounting brackets were initially designed to house three omni directional antennas and allows the backhaul antennas to be configured either horizontally or vertically, while the service antenna is installed so as to be horizontally polarized. The overall design of the payload is flexible enough to adopt several different configurations. The brackets that are used for the payload are fashioned from angle aluminum available at local hardware stores which is then custom cut and drilled, and then secured using the supplied bolts (Figures 10 and 11).

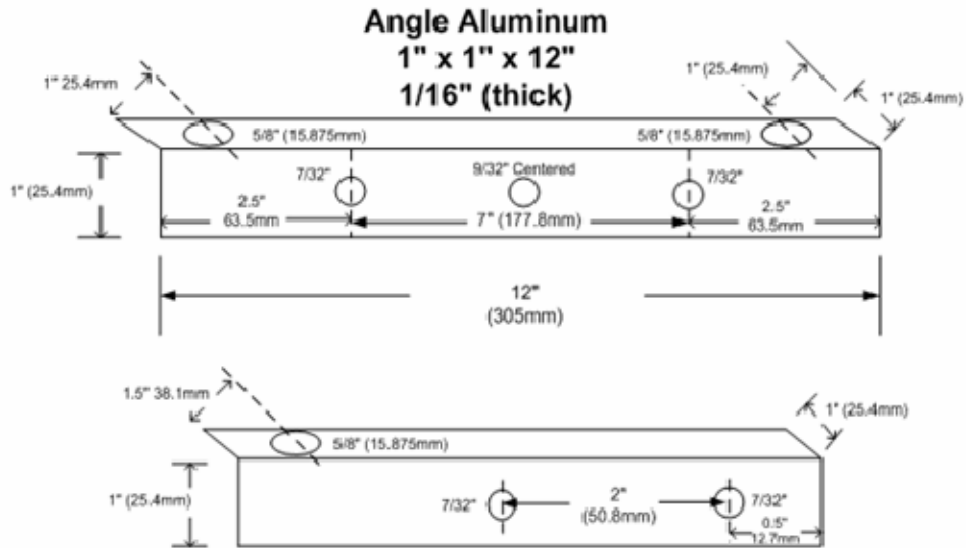

Figure 10. Angle aluminum design diagram



Figure 11. Angle Aluminum and Bolts

To fasten the MD AP to the balloon a 40 inch sling, designed for rappelling and rock climbing, is used (Figure 12). Figure 13 shows the details of affixing the aluminum brackets to the MD AP. A simple overhand knot is tied 6 inches from the top and another is tied 8 inches from the bottom. A locking carabineer is used at each end of the sling to attach the sling inline with the tether of the balloon (Figure 14). Figure 15 shows the brackets and sling fastened to the payload ready for deployment.



Figure 12. Sling with battery attached

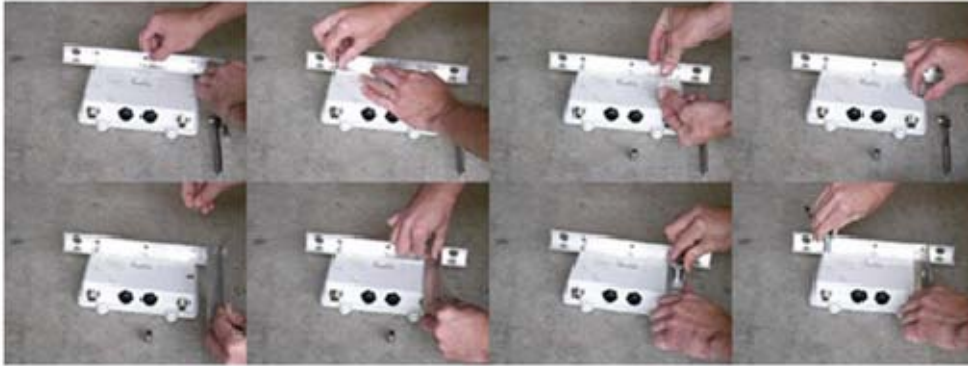

Figure 13. Fastening brackets on the MD AP



Figure 14. COASTS 2006 Payload attached to balloon

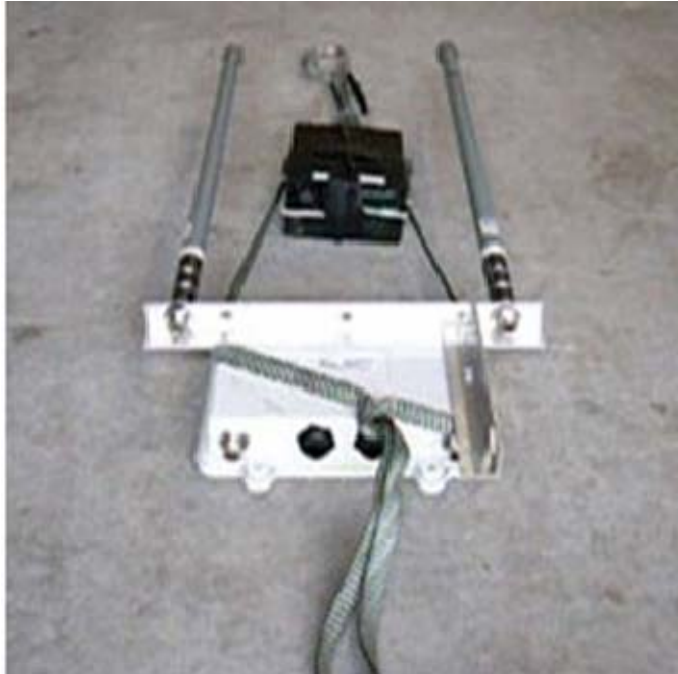

Figure 15. COASTS 2006 Payload with sling and battery attached

The battery is fastened to the payload with a 6 foot piece of 550 cord, a commonly used military rope. Figure 16 demonstrates tying the cord around the battery. In addition to tying the cord securely to help ensure the cord will not slip, electrical tape is wrapped around the center of the battery both lengthwise (through the loop and over the knot) and widthwise (see Figure 16 last frame.)

The battery is then fastened to the sling by placing a carabineer through the short loop in the sling and slipping it through the loop of the 550 cord on the battery. Next, two plastic ties are used to secure the 550 cord to the sling just below the horizontal electrical tape, one on each side (See Figure 17).

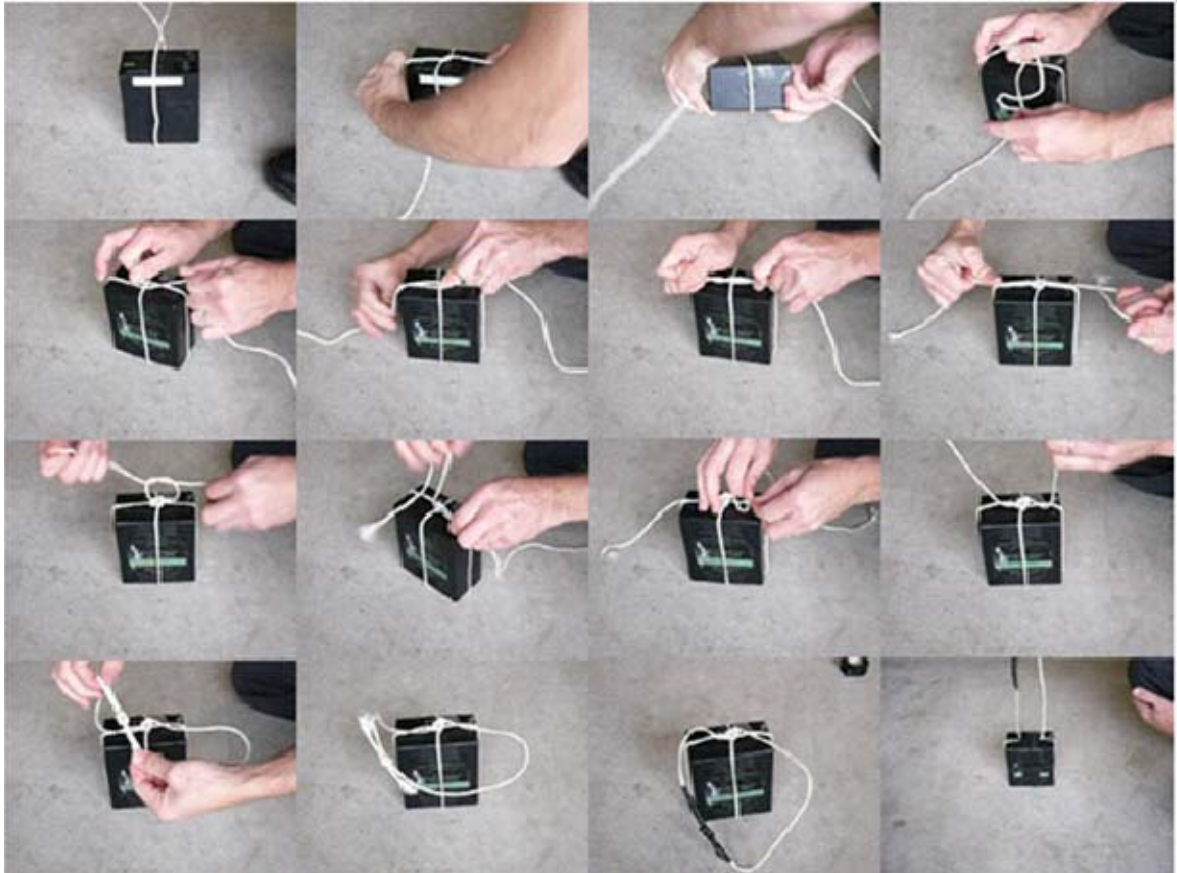

Figure 16. Tying the battery



Figure 17. UBI-2590 Battery secured on sling

Once the brackets have been installed on the MD AP and the battery is fastened on the sling, the sling is ready to be fastened to the brackets. The antennas may be fastened on as well (Figure 18).



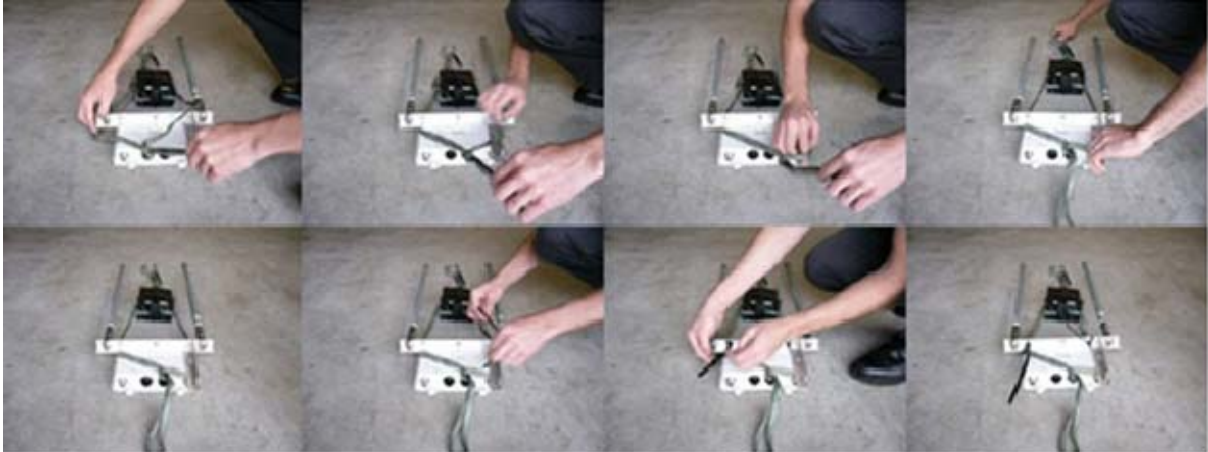

Figure 18. Securing sling on brackets

Now it's time for the camera bracket (optional). Again, aluminum was used to make the bracket (Figure 19 and 20). A stainless steel bolt measuring  $\frac{1}{4}$ " x  $\frac{3}{4}$ " is used to fasten the camera bracket to the horizontal aluminum bracket mounted on the MD AP shown earlier. Nylon lock nuts are used to ensure the hardware stays tight. Figure 21 shows this bracket being installed.

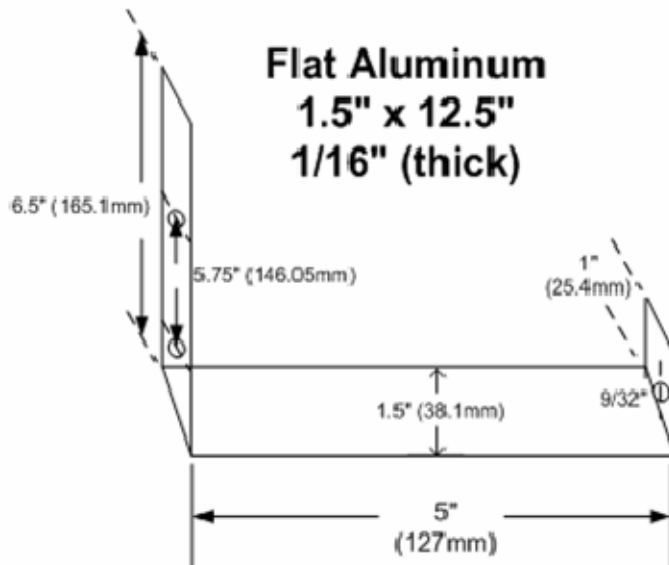

Figure 19. Camera bracket diagram



Figure 20. Camera bracket, bolt, and nut



Figure 21. Installing the camera bracket

With the camera bracket in place, the camera is then installed (Figure 22). Stainless steel hardware and nylon locknuts are used here as well (see Figure 20). Power wiring details are provided in Appendix A.

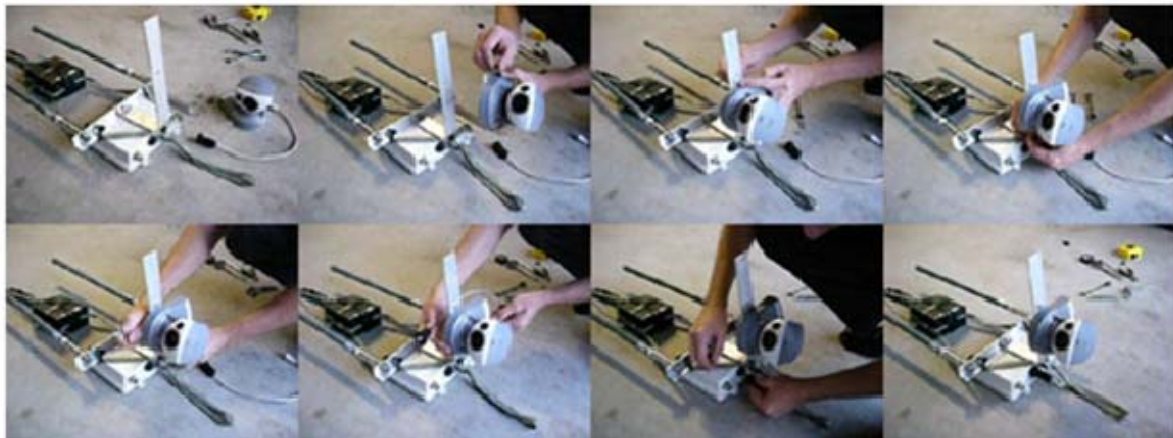

Figure 22. Axis 213 camera installation



Next, the antenna and power cables are installed to complete the payload (Figure 23).



Figure 23. Cable installation

Once the cables are installed, making certain they will not protrude in the camera's view area, nor interfere with the camera's operation, the payload is ready to be attached to the balloon as shown in Figure 24.



Figure 24. Completely assembled payload with camera

Figure 25 shows the payload attached to the balloon. Note that this payload is set up with the backhaul antennas horizontally polarized. Drilling the angle aluminum, shown

in Figure 10, with mounting holes on both sides allows for this easy antenna polarization change. A complete list of materials and their weights for this payload design is provided in Appendix A.



Figure 25. Payload attached to the balloon

### **3. Initial Implementation Results**

In December 2005, the COASTS research group performed an initial deployment of the COASTS 2006 suite at Pt Sur, California (referred to as Pt Sur I.) This was the first test of this payload design.

The first day of the test, the group was met with high surface winds gusting from 14 - 17 knots. This was not ideal weather for testing the operation of the equipment but it was excellent weather for testing the durability of the payload solution. Figure 26 shows the payload affixed to a balloon while trying to raise it in high wind conditions.

The winds were simply too strong and prohibited the payload from ascending. As a result aerial operations were grounded for the day.



Figure 26. Payload in 14-17 Knot Winds at Pt Sur I

The following days provided excellent weather. The payload design performed well and was light enough to allow the balloon to ascend to an estimated maximum altitude of 1400 feet before the balloon simply ran out of lift. The payload did tend to spin and sway in breezy conditions, however. The addition of a simple wind sock during the Thailand deployment dramatically reduced the swaying.

One day, at the Pt Sur I test, brought light rain. Again, the payload performed well with only minor weather proofing of the cable connectors (using 3M rubber and electrical tape) along with placing a plastic bag over the camera. Suggestions for improvements in this area are also provided in a later chapter.

### III. THE TACTICAL IEEE 802.11 NETWORK

#### A. COASTS 2005 IEEE 802.11 NETWORK

##### 1. Equipment

The COASTS 2005 network was designed to facilitate the decision maker's ability to amass real-time target-to-shooter, enemy movement, and force deployment data into information. The topology, Figure 27, employed various versions of Rajant Technologies BreadCrumbs (Figure 3). The layout included connecting the Royal Thai Air Force (RTAF) Wing 2 Communications Building, Wing 2 Air tower, and a distant aerial balloon node which provided service to tactical users in the scenario (Operations Order 04-05).

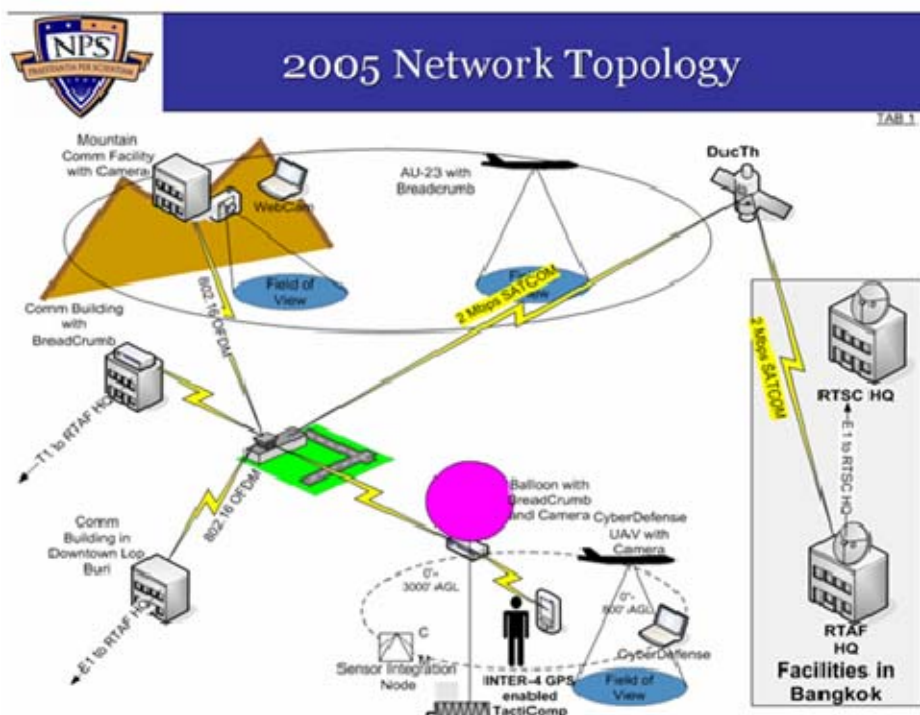

Figure 27. COASTS 2005 Network Topology  
(From Operations Order 04-05 22)

BreadCrumbs deployed during COASTS 2005 included the following models: XL, SE, and ME (Figure 3). The family of devices is IEEE 802.11b compliant, varying in size, power, and range. An XL, for example, is advertised to have a 10 mile range, the SE 0.5 miles and the ME is 0.5 miles (Rajant). A modified XL was employed on the aerial balloon payload. At the Command Operations Center (COC), at the Wing 2 Air Tower, two BreadCrumbs were employed, an XL, and an SE.

During the COSATS 2005 field experiment the following antennas were utilized: (pictured left to right in Figure 28) Hyperlink Technologies HG2415Y 14.5 dBi Yagi, Rajant Technologies 8dBi omni, Hyperlink Technologies HG2408U 8dBi omni, WiFi-Plus MP Tech 5dBi multi-polarized omni.



Figure 28. COASTS 2005 Antennas (From Lee 38)

Various antenna configurations were employed during COASTS 2005. These included (Lee):

- 18dBi flat panel (model unspecified) at the COC connected to a BreadCrumb SE aimed at the aerial node and other distant BreadCrumbs
- 8dBi omni connected to a BreadCrumb XL also located at the COC
- 14.5dBi Yagi connected to a BreadCrumb
- 8dBi omni affixed horizontally to the aerial payload
- 8dBi omni dangled from the aerial payload
- MP 5dBi omni affixed to the bottom of the aerial payload mounted upside down propagating toward the earth

## **2. COASTS 2005 IEEE 802.11 Lessons Learned**

As detailed in LT Lee's thesis, the COASTS 2005 802.11 portion of the network suffered many difficulties. Issues with the Rajant Technologies BreadCrumb devices themselves as well as configuration of antennas to enable the devices to communicate to each other produced many hurdles which were difficult for the team to overcome in the field. The following lessons learned and recommendations relevant to this thesis are quoted directly from the COASTS 2005 AAR included in LT Lee's thesis. These recommendations and lessons learned form the basis for this research and ensure similar mistakes are avoided for COASTS 2006. The recommendations are grouped and ordered to facilitate a discussion of their importance in influencing selection of the COASTS 2006 IEEE 802.11 equipment and antennas.

- Change the color of the boxes (black is not a good color for heat). (Lee 167)
- The Rajant breadcrumbs are not a reliable solution in this hostile environment. Rajant needs to research improving reliability in this kind of environment or COASTS needs to research replacing with a better breadcrumb. (Lee 167)

- The maximum throughput achieved was 11 Mbps for <3 minutes. Found that the Breadcrumbs are susceptible to high temperature conditions and humidity. These devices need some sort of internal fan or environmental control when used in environments such as Thailand. (Lee 172)
- BCAdmin uses about 2 Mbps of network traffic per operating client. The number of clients running should be limited to provide more bandwidth. (Lee 167)
- Upgrade standard to 802.11g or 802.11n for better distance and speed. (Lee 167)
- For future deployment, recommend using SE for all Ethernet required connections, such as cameras, due to their reliable RJ45 interface and using ME for linking and redundant nodes, due to their dual external antennas. (Lee 167)
- To properly employ the Rajant breadcrumbs in this hostile environment, it is very important to employ an overlapping, redundant mesh. Single breadcrumbs would work less reliable than two co-located breadcrumbs. In fact the team would have been unable to meet our network requirements if it had not been for the 4 breadcrumbs and cable connectors returned from the Phuket Tsunami Relief Area. (Lee 168)
- If balloons are utilized in the future, they should contain two separate bread crumbs and more than one balloon should be used in a given footprint. (Lee 169)

The above notes illustrate that the Rajant BreadCrumbs did not perform as expected during COASTS 2005. Issues with proper operation point to less than optimal form factor (primarily consisting of materials and color used to enclose the sensitive electronic components). Also, because of the overhead associated with the IEEE 802.11 standard implementation as well as the overhead associated with the BreadCrumb administration software, a less than advertised bandwidth left little throughput for which to

conduct operations. As a result, BreadCrumbs are not part of the 2006 network. Instead the Mesh Dynamics WMN access points, which have a high power, three radio, three antenna design and can utilize the IEEE 802.11b/g and IEEE 802.11a standards, will be implemented. As suggested, COASTS 2006 implements an IEEE 802.11 b/g capable with an IEEE 802.11g only client network to ensure the highest available throughput can be achieved. With a more robust design and being encased in a white aluminum enclosure, which is National Marine Electronics Association (NMEA) rated, these access points proved to perform very well in the austere Thailand climate. As far as the redundancy suggestion, COASTS 2006 deployed the network at intervals which were much closer than necessary to gain both redundancy and enhanced coverage in the AOR.

- The balloon is ideally operated during moderate winds below 10 knots. This is not an all weather balloon. Extreme heat and solar conditions causes some deterioration of balloon material. Winds greater than 10 knots must be in a consistent direction. With swirling winds, the kite flap causes the balloon to twist with the changing winds and if the winds exceed 10 knots violent swirls have been observed. (Lee 174)
- A super crumb should be tested again as the payload on the balloon. A multi-polar antenna should be used for radio signals. (Lee 175)
- [Referencing the 5dBi multi-polar antenna] One significant data point was taken while using the multi-polar antenna at a fixed ground location. The antenna was positioned on top of a 20-foot light pole. When the accompanied Breadcrumb was turned on, the network instantly connected with a data throughput of 11 Mbps between all nodes. This was quite impressive because the signal went through 50 yards of



underbrush and a tree-line, connecting the COC to the local network, transmitting to the balloon, and connecting every local unit within 300 yards to the main network. Again, this connection did not last long, approximately 15 minutes, but the signal lasted long enough to show the capability of this antenna. (Lee 43)

- [Referencing Balloon Node goals accomplished] Maximum continuous throughput achieved was ~ 2Mbps. The most optimal antenna configuration seen during the demonstration was a horizontal and vertical dipole staged 90 degrees apart. (Lee 171)
- DLINK AP2100 Wireless Access Points were linked with 14.5 dBi Yagi Antennas with a nearly perfect point-to point bridge for providing constant and consistent T1 connectivity between the Wing 2 Comm Center and the Command Operations Center (COC). (Lee 167)
- Distance for SE, ME with 8 dBi omni-direction external antenna was limited to 300 meters with partial to full line of sight for 11 Mbps. The SE internal/ ME external 1 dBi antennas were limited to roughly 100 meters for a full 11 Mbps. (Lee 166)
- The ideal configuration for the command center was to hardwire through an Ethernet cable to an XL with an external 8 dBi omni-directional external antenna. Collocated with an SE connected to an 18 dBi flat-panel external antenna, directed in the direction of a balloon or other large distance breadcrumbs. (Lee 166)
- All antennas need to be 6ft off the deck to get best signal propagation. (Lee 167)

The notes above allude to various aspects of what worked well with respect to antenna configuration for COASTS 2005. The first three notes, along with the testing of the antennas available during the course of this thesis, lead to the selection of what is proved to be the optimum antenna for communicating with the aerial nodes and ground based clients, two versions of the WiFi-Plus multi-polar

antenna. The first bullet discusses the dramatic movement of the aerial payload. It is suspect that this would cause any singularly polarized antenna to be at a disadvantage allowing intermittent connectivity at best. This would be due to the varying polarization the movement of the aerial payload would cause, which leads to the amount of received energy falling off as the cosine of the angle (Antenna Letter). According to LT Lee, the antenna configuration which gave the highest continuous throughput seen during COASTS 2005 on the aerial node was a horizontal and vertical dipole staged 90° apart (Lee 171). This was a crude multi-polar setup. Utilizing the 5dBi multi-polar antenna, with its 360° horizontal and 180° vertical beam width, for the 2006 network will eliminate any adverse effect on connectivity for an aerial node due to movement having.

The rest of the notes indicate various ground based antenna configurations. Distances associated of course are not only dependent on antenna selection but must also consider the entire link to include transmitter output, receiver sensitivity, and cable, connector, and free space losses. These factors are discussed later in the chapter. The greatest throughput on the ground, as noted by LT Lee, was 11Mbps. This was accomplished using the 5dBi multi-polar antenna mounted on a 20ft pole, again suggesting that the multi-polar antenna is an optimal solution.

Due to the lack of an 802.11 antenna specific study during the COASTS 2005 field experiment, many antenna configuration and performance aspects for the deployment remain unclear, however, it was made abundantly evident

that the limiting factor for the entire COASTS 2005 IEEE 802.11 network was the antenna configuration (Lee 49), hence the focus on determining the optimum antenna configuration for the COASTS 2006 802.11 network.

## B. COASTS 2006 IEEE 802.11 NETWORK

### 1. Topology

For 2006, COASTS needed to provide a robust IEEE 802.11 WMN to enable seamless network connectivity for sensor, UAV and mobile client operations throughout the AO.

Given the location of the COASTS 2006 international field experiment, the team set out to build and test the tactical network over several smaller field experiments. The international field experiment location and scenario drove the network topology. Figure 29 is a satellite view of the target AOR and overlay of the network topology. Figures 30 and 31 show the node placement and desired coverage of the IEEE 802.11 portion of the network.



Figure 29. COASTS 2006 Network Topology  
(From CONOPS 2006 4)



Figure 30. COASTS 2006 802.11 Network Topology  
Mae Ngat Dam, Chiang Mai, Thailand



Figure 31. View of COASTS 2006 802.11 Topology

## 2. Equipment

In order to achieve the desired coverage for the COASTS 2006 international field experiment, improved IEEE 802.11 gear was selected. The IEEE 802.11 equipment chosen for COASTS 2006 are the Mesh Dynamics multi-radio backhaul access points (see Figure 34). These were chosen for their many performance improvements over the Rajant Technologies BreadCrumbs used during COASTS 2005. The main improvements are highlighted below.

- Aluminum NMEA enclosure has superior thermal characteristics over the black plastic enclosure used for the BreadCrumbs
  - Thermal Characteristics
    - Enclosure Seal Operating temperature -60C to 230C
    - Heat Trap: +6.5 Celsius under full sun (~100,000 Lux)
    - Temperature raise using a 5-10Watt heat source (WRAP + radio board): +5.5 Celsius ("Specifications")
- Multi-radio backhaul provides 64 times the bandwidth distribution of other mesh designs ("Why Structured Mesh")

Perhaps the greatest reason for selecting Mesh Dynamics is the claimed improved bandwidth over single-radio implementations of mesh networks. According to Mesh Dynamics a single-radio unit uses the same radio to both send and receive which cannot be accomplished simultaneously. The access points (nodes) listen then retransmit. Also, all nodes operate on the same channel which, depending on the topology, causes a 50% bandwidth loss for each hop. ("Why Structured Mesh")



Figure 32. Mesh Dynamics Multi-radio Structured Mesh Network Access Point

The Mesh Dynamics access points are highly configurable allowing varying radio powers, operating frequencies, IEEE 802.11 a/b/g standards, and software configurations to suit specific applications. Device configurations employed during initial COASTS 2006 field experiments (FX) are listed in Table 1. For detailed model number breakdown see Table 2.

<b>Model</b>	<b>Specifications</b>
MD4350-AAIx-1110	Four slot mini-PCI motherboard with two 400mW Ubiquity SuperRange 5, IEEE 802.11a, 5.8GHz backhaul radios, one 400mW Ubiquity SuperRange 2, IEEE 802.11b/g 2.4GHz service radios with basic software features
MD4325-GGxx-1100	Four slot mini-PCI motherboard with two 400mW Ubiquity SuperRange 2, IEEE 802.11b/g, 2.4GHz backhaul/service radios, one 64mW 2.4GHz scanning radio with mobility software features

Table 1. Initial COASTS 2006 FX Mesh Dynamics Access Point Configurations

<b>*Four Position Numerical Designator</b>	<b>Four Position Radio Configuration</b>	<b>Four Position Radio Type</b>
Number of Available Mini-PCI slots (1 - 4)	Backhaul Radio (A = 802.11a, G = 802.11g)	One number per available slot (0 = 64mW, 1 = 400mW, remains "0" if radio not installed)
Number of installed radios (1 - 4)	Service Radio (B = 802.11b, G = 802.11g, I = 802.11b/g )	One number per available slot (0 = 64mW, 1 = 400mW, remains "0" if radio not installed)
Backhaul Frequency (2 = 2.4GHz, 5 = 5.8GHz)	(x = no radio)	One number per available slot (0 = 64mW, 1 = 400mW, remains "0" if radio not installed)
Software Features (0 = Basic, 2 = multi-root, 5 = Mobility)	*MD represents Mesh Dynamics	One number per available slot (0 = 64mW, 1 = 400mW, remains "0" if radio not installed)

Table 2. Mesh Dynamics Access Point Model Number Breakdown

THIS PAGE INTENTIONALLY LEFT BLANK

## IV. COASTS 2006 FIELD EXPERIMENTS

Selecting the optimum antenna for the best possible node to node throughput and range seems fairly straight forward from a theoretical point of view. However, operating with last year's gear, on a tight time line, on less than optimal testing grounds, with limited funds, all culminate to make the task a challenging one. This section details how the optimum antenna selection evolved.

### A. BACKGROUND

As stated earlier, COASTS 2005 saw the best throughput on the ground with the multi-polar 5dBi antenna. Again, due to the lack of an antenna specific study in this area, and the fact that this throughput lasted only 15 minutes, no credible conclusion could be drawn that this particular antenna is unequivocally optimal. As stated by LT Lee in his thesis, "The limiting factor in this network was found to be antenna configuration. The antennae used during the experiment had different polarizations, which hampered network development." With that finding, this research study was conceived.

As addressed in the opening section, COASTS 2006 was conducted on a limited budget. With the previous year's iteration under its belt, it was in COASTS' best interest to ensure the 2006 participants were extremely familiar with the equipment they would be deploying. This brought about an accelerated series of tests of the proposed 2006 topology to ensure the projects success. Through a Cooperative Research and Development Agreement (CRADA) with Mercury Data Systems (MDS), the COASTS team was able to



borrow the necessary gear to perform an initial deployment of the network. MDS assists COASTS with technical aspects of the network equipment and made recommendations on antenna selection for the first deployment to Pt. Sur.

## **B. PRE THAILAND FIELD EXPERIMENTS**

This section details the field experiments that took place prior to deploying the network at Mae Ngat Dam, Chiang Mai, Thailand. Results from these experiments, as well as equipment availability, lead the team to the conclusion that additional configurations would be needed to be tested once in Thailand. Optimum antenna configuration determinations were made prior to departing for Thailand and are presented at the end of this section. The details from the Thailand FX are presented later in the chapter.

### **1. Method**

Testing the throughput on a single hop was an iterative process. Each antenna configuration was tested at increasing distances in an attempt to determine the point at which throughput began to diminish. However, much of the time the taper off point was never reached. This was due to LOS distance limitations of the test locations. This did not hamper the ultimate goal of the activity as the deployment location for COASTS 2006 requires redundancy and overlapping coverage which has the nodes at distances much shorter than maximum range.

The root node was physically connected to a Cisco 2811 router, powered through a PoE adapter and placed on a stationary tripod and mast setup at a starting height of 10

- 12 feet. This height allowed for the required 60% unobstructed radius of the Fresnel Zone for this set of tests (Planet3 Wireless 89 - 91). The target distances are listed in Table 3. The downstream node was powered using an Ultralife UBI2590 lithium polymer battery, placed on a tripod and mast setup, placed in the bed of a truck for ease in increasing distance between the nodes and the antenna heights matched (See Figure 34).

Range (miles)	Fresnel Zone Radius (feet)	
	2.4GHz	5.8GHz
0.10	4.42	2.84
0.20	6.25	4.02
0.30	7.65	4.92
0.40	8.84	5.69
0.50	9.88	6.36
0.60	10.83	6.96
0.70	11.69	7.52
0.80	12.50	8.04
0.90	13.26	8.53
1.00	13.98	8.99

Table 3. 60% Fresnel Zone Calculation

Throughput testing was completed using IXIA's IxChariot ran on a Panasonic Toughbook connected to the router. The downstream client was a Dell Latitude D510 laptop which ran IxChariot endpoint software. Both computers ran Microsoft Windows XP operating system. Using IxChariot provided 100 data points for each test.

## 2. Physical Configuration of Tests

The MD access points are multiple radio units with a maximum of four radios. Each radio requires a separate antenna. The connections for the antennas vary based on the model of the access points. The MD4350-AAIx model's (used

in the ground to ground backhaul tests) antenna arrangement are: top left, upstream (refers to backhaul); bottom right, downstream (refers to backhaul); bottom left, service. All tests were performed on the backhaul link of the devices, configured to the IEEE 802.11a standard, using Ubiquity Networks 400mW radios.

Another configuration used in testing the COASTS 2006 topology (ground to air) was a node setup for mobility, top left is upstream, bottom right is downstream and top right is the scanning radio antenna. On nodes configured for dual service the additional service radio antenna attaches to the top right.

Throughput in a ground to aerial balloon node topology has proven to be a challenge for not only the COASTS research group but also for other NPS research groups as well. According to COASTS' research advisor, Mr. James Ehlert, "[research groups] have been trying to ascertain the optimal payload design and configuration for the last few years." Though connection to an aerial payload has been established, throughput has yet to be documented due to the difficulty in physically connecting an endpoint to the aerial payload.

### **3. Pt Sur Field Experiment**

The first test of the COASTS 2006 network was performed at the former Navy SOSUS station, Pt Sur, California. This is a very small compound, on which the Naval Postgraduate School maintains some meteorological equipment. Because of its small size and it being on a sloping hill, it turned out to be less than optimal for testing the proposed 2006 topology. However, due to FAA

flight restrictions in the area local to NPS, this was the only alternative that would allow unrestricted altitude deployment of the aerial nodes. COASTS members took this opportunity to become more familiar with the equipment as well as to begin individual technology assessments.

Consultation on 802.11 access point and antenna selection came in part from COASTS' cooperative research and development agreement (CRADA) partner Mercury Data Systems (MDS). MDS supplied radio frequency (RF) engineering consultation, additional Mesh Dynamics access points and antennas used for this test session. The antennas used for testing the 802.11 access point to access point backhaul range are pictured in Figure 33 and summarized in Table 4.



Figure 33. Backhaul Antennas Tested at Pt Sur  
(Top - Hyperlink 12dBi, Bottom - SuperPass 8dBi)

MANUFACTURER	MODEL	FREQUENCY MHz	GAIN dBi	Polarization	Beam width Horz/Vert	SIZE H/W/D
SuperPass	SPDJ60	5250-5900	8	Vertical	360/18	10x1
Hyperlink Technologies	HG5812U	5725-5850	12	Vertical	360/6	27x.75

Table 4. Specifications of Backhaul Antennas Tested at Pt Sur (Hyperlink Technologies, SuperPass)

The ground to ground access point backhaul throughput saw the best performance using the Hyperlink 12dBi antenna on the root node and the SuperPass 8dBi antenna on the downstream node. Note the testing results from Pt Sur, shown in Tables 5 and 6, are for informational purposes only due to the vast variance in ground slope/altitude, and therefore antenna alignments, at the site.

**12dBi to 12dBi 802.11a**

Miles	AVG Throughput
0.00	20.111
0.10	8.132
0.15	10.997
0.20	0.666
0.22	5.134

Table 5. Average Throughput 12dBi to 12dBi, Pt Sur

**12dBi to 8dBi 802.11a**

Miles	AVG Throughput
0.00	20.298
0.10	9.290
0.15	7.633
0.20	11.444
0.25	2.251
0.29	7.842
0.36	2.392

Table 6. Average Throughput 12dBi to 8dBi, Pt Sur

**4. Ft Ord Field Experiment**

The next series of tests were performed at Ft Ord; a former U.S. Army installation located near Marina, CA. Altitude at this location was more constant, varying a maximum of 8 feet. Using a tripod and mast setup allowed for better adjustments ensuring the antennas height were closely aligned. Figure 34 shows the setup for the testing

of the Hyperlink 5.8 GHz 12dBi omni antennas at Ft Ord, the same antenna introduced in Figure 33.

At this test session the manufacturer of the devices, Mesh Dynamics, sent a representative to assist with device deployment as well as to upgrade the device firmware. The new firmware allows the user the ability to adjust the acknowledgement (ACK) timing of the backhaul enabling the nodes to be at a greater distance than the previous firmware version allowed. A series of three tests were performed using 12dBi antennas with the old firmware then, later the same day, the antennas were tested in the same manner using the same setup with the new firmware. The improvement is evident in the comparison of Tables 7 and 8. In the second test (see Table 8), and all subsequent tests, the ACK timing was set to 150ms. Due to time constraints the COASTS team was only able to test the one antenna type at this location. Due to air space restriction the team was not able to fly a balloon to test the aerial node.



Figure 34. Test Setup at Ft Ord

**12dBi to 12dBi 802.11a**

	<b>AVG Throughput</b>			
<b>Miles</b>	<b>1st Run</b>	<b>2nd Run</b>	<b>3rd Run</b>	<b>Final AVG</b>
0.00	13.661	-	-	13.661
0.10	19.414	17.822	15.299	17.512
0.20	16.348	13.857	10.105	13.437
0.30	16.892	12.743	5.802	11.812
0.38	11.813	12.228	-	12.021

Table 7. Average Throughput 12dBi to 12dBi, Ft Ord

**12dBi to 12dBi 802.11a (New Firmware)**

	AVG Throughput			
Miles	1st Run	2nd Run	3rd Run	Final AVG
0.10	20.419	20.26	20.665	20.448
0.20	18.238	17.07	14.714	16.674
0.30	20.144	20.221	19.801	20.055
0.38	20.265	20.322	20.215	20.294

Table 8. Average Throughput New Firmware 12dBi, Ft Ord

**5. Ft Hunter Liggett**

Ft Hunter Liggett (FHL), located 20 miles west of Highway 101 near King City, CA, proved to be the best test location in the local area. A near level tactical training runway gave the group a LOS range of roughly one mile. Testing was performed on the same antennas as used at Pt Sur, shown in Figure 33 and detailed in Table 4. Again, these were the only available antennas in the COASTS inventory that were feasible for the given topology. Tables 9 and 10 summarize the average throughput performance of these antennas. Figure 35 shows the complete setup of the proposed topology at Ft Hunter Liggett (less one aerial payload) as seen in the Mesh Dynamics Network Management System (NMS), Mesh Viewer. The distance from the Root to Node 4 is roughly 0.96 mile.

Throughput testing for ground to air was not accomplished, again due to the inability to physically connect a device to the aerial payload at altitude. However, as displayed in Figure 33, the COASTS team was able to demonstrate that this concept can be implemented. Note that all nodes in Figure 35 display a 54Mbps connection. Experience showed that there is a correlation between this value in Mesh Viewer and raw throughput as



seen in the IxChariot tests. At 54Mbps we would expect to have a raw throughput of roughly 20Mbps or 37% of what is reported by the NMS (this is not documented by the manufacturer, and is based on COASTS empirical data collection only). Note the aerial nodes were configured as IEEE 802.11g MD4350-GG with scanning capability. The scanning capability allows the AP firmware to continually scan the available signals in the mesh and then to connect to the strongest one.

**8dBi to 8dBi 802.11a**

	<b>AVG Throughput</b>		
<b>Miles</b>	<b>1st Run</b>	<b>2nd Run</b>	<b>Final AVG</b>
0.00	21.896	21.724	21.810
0.10	20.533	21.245	20.889
0.20	20.622	20.189	20.406
0.30	20.939	16.134	18.537
0.40	17.747	12.851	15.299
0.50	2.137	14.567	8.352
0.60	9.064	15.936	12.500
0.70	12.691	13.238	12.965
0.80	12.468	11.918	12.193
0.90	11.475	13.614	12.545
0.98	10.241	12.137	11.189

Table 9. Average Throughput 8dBi to 8dBi, Ft Hunter Liggett

12dBi to 12dBi 802.11a

Miles	AVG Throughput
0.10	21.319
0.20	17.347
0.30	20.290
0.40	18.590
0.50	4.345
0.60	17.395
0.70	16.092
0.80	18.540
0.90	17.481
0.98	16.162

Table 10. Average Throughput 8dBi to 8dBi, Ft Hunter Liggett



Figure 35. Topology at Ft Hunter Liggett (Test implementation of the proposed COASTS 2006 Thailand topology) (Background From Google Earth)

Some of the antennas used in the ground to air nodes are depicted in Figure 36 and detailed in Table 11. Pictures and specifications for some of the actual antennas used in setting up the network depicted in Figure 35, specifically the 5.5dBi and 6.5dBi Hyperlink Technologies

antennas used on Balloon 2, are not available on the manufacturer's website and may have been discontinued.



Figure 36. Aerial Payload and Antennas  
 (Left Hyperlink Tech HG2408P 8dBi; Right SuperPass SPFPG9-V100 7dBi used on Balloon 1 in Figure 35 (From Superpass))

MANUFACTURER	MODEL	FREQUENCY MHz	GAIN dBi	Beam width Horz/Vert	SIZE H/W/D inches	Notes
Hyperlink Technologies	HG2408P	2400 - 2500	8	75/65	4 dia x 1	Tested but not reliable
Hyperlink Technologies	UNK	2400 - 2500	5.5	UNK	UNK	Worked well but may no longer be available
Hyperlink Technologies	UNK	2400 - 2500	6.5	UNK	UNK	Worked well but may no longer be available
SuperPass	SPFPG9-V100	2400 - 2483	7	60/100	4.5x4.4x1	Worked well

Table 11. Antennas used in Aerial IEEE 802.11g Nodes, Ft Hunter Liggett (No throughput testing performed)

**a. Optimum Antenna Configuration Consideration**

At this point there was enough data to consider an optimum antenna configuration, which could be provided with the previously tested antennas, in support of the Thailand deployment. However, tests on the WiFi-Plus multi-polar antennas had not been conducted due to resource constraints.

The optimum antenna determination was accomplished through two main considerations. The first consideration is link budget estimation; the second is analysis of the testing performed on the various antennas. This researcher began with the link budget estimation.

1. Link Budget Estimation. Radio frequency link budget estimation is the method used in predicting/modeling the required radio powers, sensitivities, antenna gains, etc., needed to establish a reliable connection in a given frequency over a given distance. Pre-programmed calculators for this purpose are readily available on the internet. The calculator used in this estimation was found at <http://www.afar.net> and is depicted in Figure 37. Table 12 details the various parameters and results from the calculations. Calculations were performed using Ubiquity Networks SuperRange5 and SuperRange2 radio specifications [11, 12]. A fade margin of 8dB was arbitrarily chosen for the calculations. The transmitter power and receive sensitivities chosen are what the radio specifications detail as having the maximum throughput connection of 54Mbps. The resulting distance is what one can theoretically expect to achieve.

## RF Link Budget Calculator



<http://www.afar.net>

**Input:**

Frequency:  MHz

Transmit Power:  dBm

Cable 1 loss:  dB

Antenna 1 gain:  dBi

Distance:

Antenna 2 gain:  dBi

Cable 2 loss:  dB

Receiver Sensitivity:  dBm

Fade Margin:  dB

**Compute:**

Distance

Transmit Power

Fade Margin

**Units:**

Km

Miles

**Output:**

**Distance: 0.9 Miles**

Free Space Loss: 104.0 dB

Receive Signal Strength: -60.0 dBm

---

### Cable Loss Calculator

Cable Type:

Cable Length:  feet

No. of Connectors:

Loss per 100 feet:  dB  
(at 2462 MHz)

**Total Cable Loss: 0.5 dB**

Figure 37. RF Link Budget Calculator  
(From Afar Communications, Inc.)

Freq	Transmit			Receive			Fade Margin dB	Distance Miles	Results	
	Transmitter Power dBm	Cable Loss dB	Antenna Gain dBi	Antenna Gain dBi	Cable Loss dB	Receiver Sensitivity dBm			Free Space Loss dB	Receive Signal Strength dBm
<b>Tested Antenna Gains</b>										
5180	21	0.5	12	12	0.5	-74	8	0.9	110	-66
5805	21	0.5	12	12	0.5	-74	8	0.8	110	-66
2412	21	0.5	12	12	0.5	-74	8	1.9	110	-66
2462	21	0.5	12	12	0.5	-74	8	1.9	110	-66
5180	21	0.5	8	8	0.5	-74	8	0.4	102	-66
5805	21	0.5	8	8	0.5	-74	8	0.3	102	-66
2412	21	0.5	8	8	0.5	-74	8	0.8	102	-66
2462	21	0.5	8	8	0.5	-74	8	0.8	102	-66
<b>Antenna Gains to be Implemented in Proposed Topology</b>										
5180	21	0.6	13	13	0.6	-74	8	1.1	111.8	-66
5805	21	0.6	13	13	0.6	-74	8	1	11.8	-66
2412	21	0.6	13	13	0.6	-74	8	2.4	111.8	-66
2462	21	0.6	13	13	0.6	-74	8	2.3	111.8	-66
5180	21	0.5	5	5	0.5	-74	8	0.2	96	-66
5805	21	0.5	5	5	0.5	-74	8	0.2	96	-66
2412	21	0.5	5	5	0.5	-74	8	0.4	96	-66
2462	21	0.5	5	5	0.5	-74	8	0.4	96	-66
2412	21	.06	13	5	0.5	-74	8	1	103.9	-66
2462	21	.06	13	5	0.5	-74	8	0.9	103.9	-66

Table 12. RF Link Budget Estimation at the Upper and Lower Channels of the IEEE 802.11a and IEEE 802.11g Specifications (Using Ubiquity Networks SuperRange5 and SuperRange2 Radio specifications)

2. Antenna Selection. With the link budget estimations complete, one can now analyze the results of the throughput testing. Average throughput results from each of the two antennas tested at FHL are compared side-by-side in Figure 36. Only FHL results are considered due to the firmware and ground elevation variations in the previous tests.

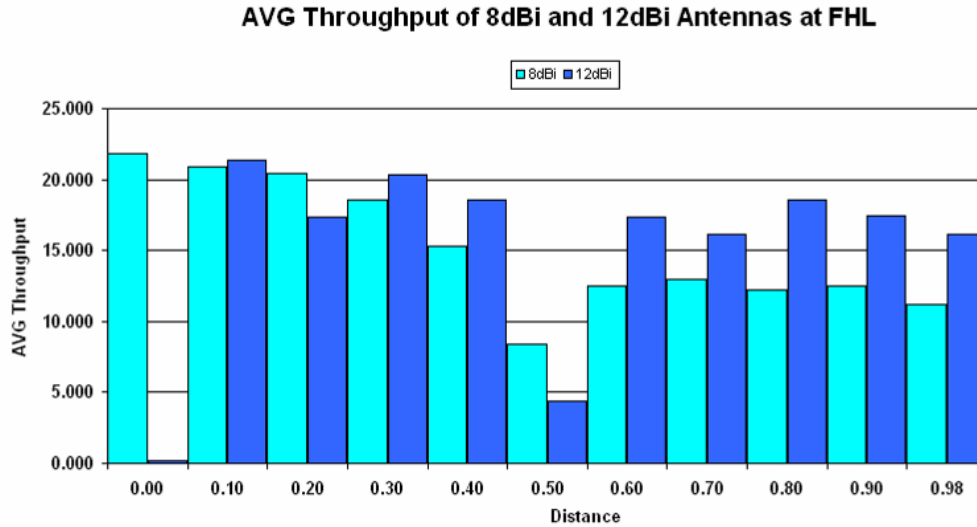

Figure 38. Comparison of 8dBi and 12dBi Antenna Throughputs in the IEEE 802.11a Standard

[It is acknowledged that the graph shows a dip at the 0.5 mile point both antennas show a drop in throughput. This is likely due to a slight change in elevation which was not corrected for during testing causing the antennas to be out of alignment resulting in degraded performance.]

It is apparent that as range increases the higher gain antenna is able to maintain a higher throughput. This reality is suggested in the RF link budget calculation which shows that the 12dBi antennas should perform optimally through a distance of 0.8 - 0.9 miles. For the COASTS 2006 topology, a half-moon shaped distance of 1.2 miles needs to be covered. Judging by the test results, to ensure maximum throughput is attained with a reasonable footprint, a topology in which four nodes are deployed at 0.4 mile intervals using 12dBi antennas should provide the best performance. Figure 30 depicts this philosophy.

Other considerations for the COASTS 2006 topology include the ground to air backhaul solution and

the varied environments that the topology would experience. With a helium filled balloon flying the aerial node, changes in polarization, due to the movement of the node in winds, is expected. Implementing a singularly polarized antenna solution would likely hamper throughput in this dynamic environment. A better antenna solution would be a multi-polarized one which would not be affected by these polarization changes. This type of antenna would also perform better in environments in which vegetation must be penetrated (according to the antenna manufacturer - no testing in this area has been performed by the COASTS research group) ("WiFi-Plus Tech Explained"). The antenna suggested by LT Lee, the WiFi-Plus Multi-Polar 5dBi, fits these requirements. Another antenna from the same manufacturer, the 13dBi MP sector, also qualifies and has the extra gain needed to ensure maximum throughput at longer distances. Another attractive point to these antennas is that they operate in both the 2.4GHz and 5.8GHz bands. These antennas are depicted in Figure 39. Their specifications can be found in Figures 40 - 42, and Table 13.

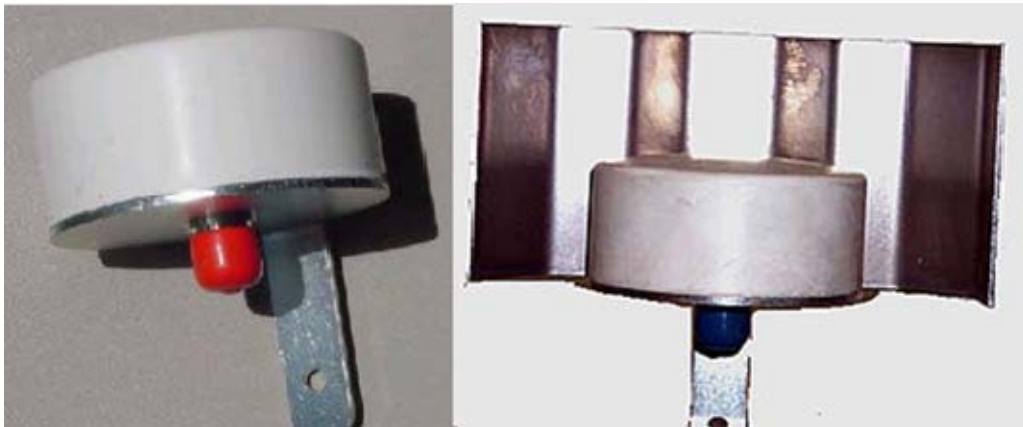

Figure 39. WiFi-Plus MP 5dBi (left) and 13dBi MP Sector Antennas (From WiFi-Plus)



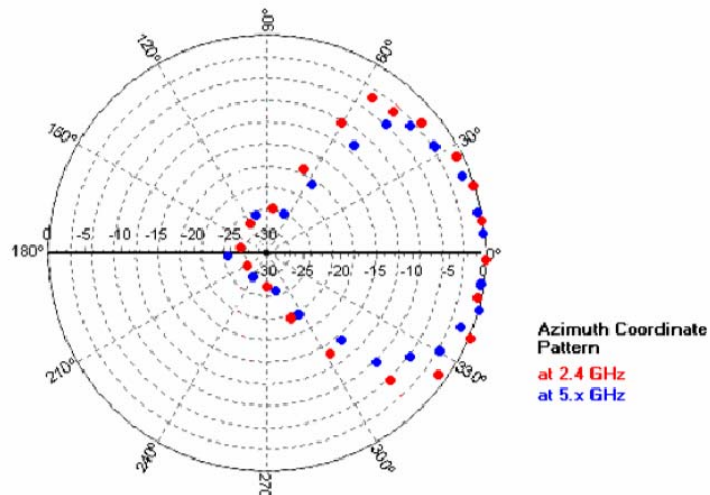

Figure 40. WiFi-Plus 13dBi MP Single Sector Azimuth Coordinate Pattern (From "MP-Tech. 'Single Sector' Antenna WFP0200508 120 Degrees Coverage.")

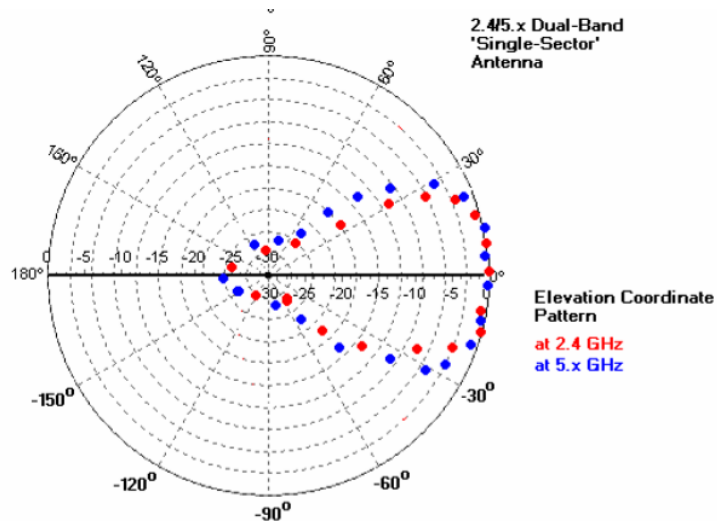

Figure 41. WiFi-Plus 13dBi MP Single Sector Elevation Coordinate Pattern (From "MP-Tech. 'Single Sector' Antenna WFP0200508 120 Degrees Coverage.")

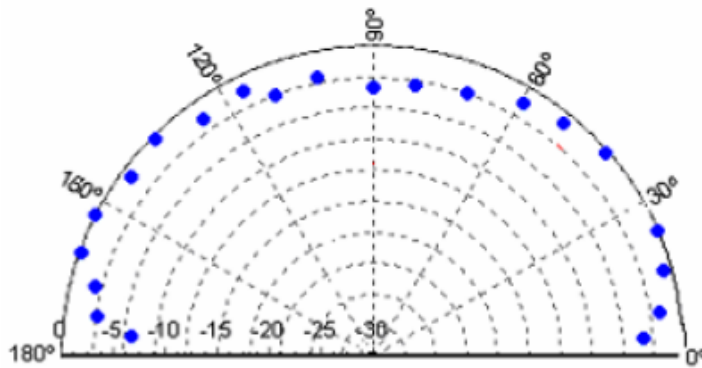

Figure 42. WiFi-Plus MP-Tech. 5dBi Omni Elevation Coordination Pattern Plot (From WiFi-Plus)

MANUFACTURER	MODEL	FREQUENCY MHz	GAIN dBi	Beam width Horz/Vert	SIZE H/W/D in
WiFi-Plus	MP-Tech. 5 dBi OMNI	2400-2500 / 5150- 5850	5	360/180	3.5 dia x 1.5
WiFi-Plus	13dBi MP Single Stack Sector	2400-2500 / 5150- 5850	13	120/40 2.4GHz & 90/40 5.8GHz	3.5" X 7" X 3.5"

Table 13. WiFi-Plus MP 5dBi and 13dBi MP Sector Antenna Specifications (After WiFi-Plus)

Figure 43 depicts an estimation of the various ranges and coverage thought to be needed at this point in the research to enable a robust network during the Thailand field experiment. Three aerial nodes were planned. The maximum transmit range for this was estimated to be 3,406 feet. These nodes were planned to operate under the IEEE 802.11g standard in the 2.4GHz band which, as shown in Table 12, allows for greater range than does the 5.8GHz band. Running link budget estimation with the 13dBi MP sector on the root node and a 5dBi MP on the aerial node reveals an expected range of one mile (see Table 12) which easily fits the estimated required range. Using the 13dBi sector on the Root Node would allow coverage for both

Balloon 1 and Balloon 2 in the topology. Similarly for Node 4, using a 13dBi MP sector here would allow connectivity for Balloon 3 and Balloon 2.

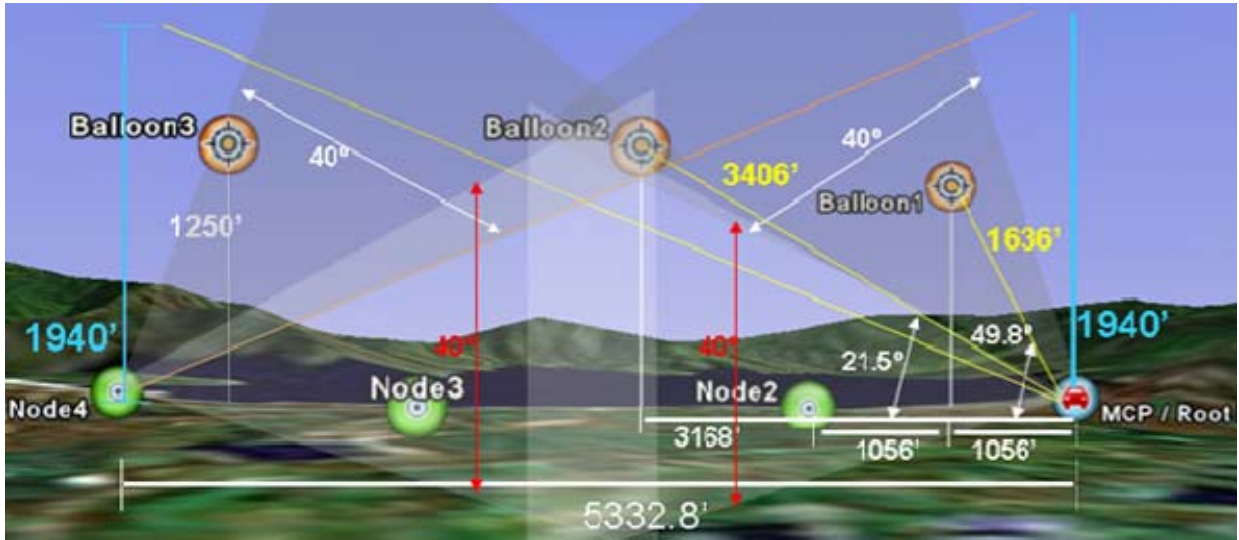

Figure 43. COASTS 2006 Proposed Topology Coverage Requirements (Background From Google Earth)

**C. MAE NGAT DAM, CHIANG MAI, THAILAND, FIELD EXPERIMENT**

For the final field experiment, the WiFi-Plus Multi-Polar antennas were available and tested. Also available were IEEE 802.11g compliant, 400mW, mini-PCI radios which enabled the team to perform tests using the Mesh Dynamics AP's in both the IEEE 802.11a and 802.11g standards. Several configurations and ranges were evaluated. The following figures provide details of the tests. Full details of the test data are provided in Appendix B. Figures 44, 45, and 46 familiarize the reader with the test location, Mae Ngat Dam, in the Chiang Mai province of Thailand. Figure 47 depicts the distances which were afforded by this location for testing. Figure 48 is a panoramic view of the test site. This location offered an

extremely harsh environment where the maximum recorded on site temperature reached 111.1°F.

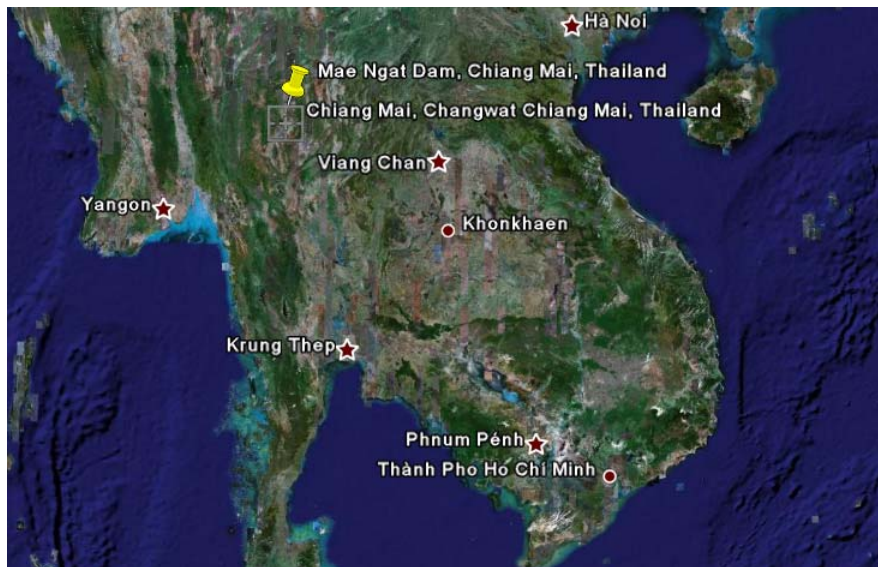

Figure 44. Mae Ngat Dam, Chiang Mai, Thailand (From Google Earth)

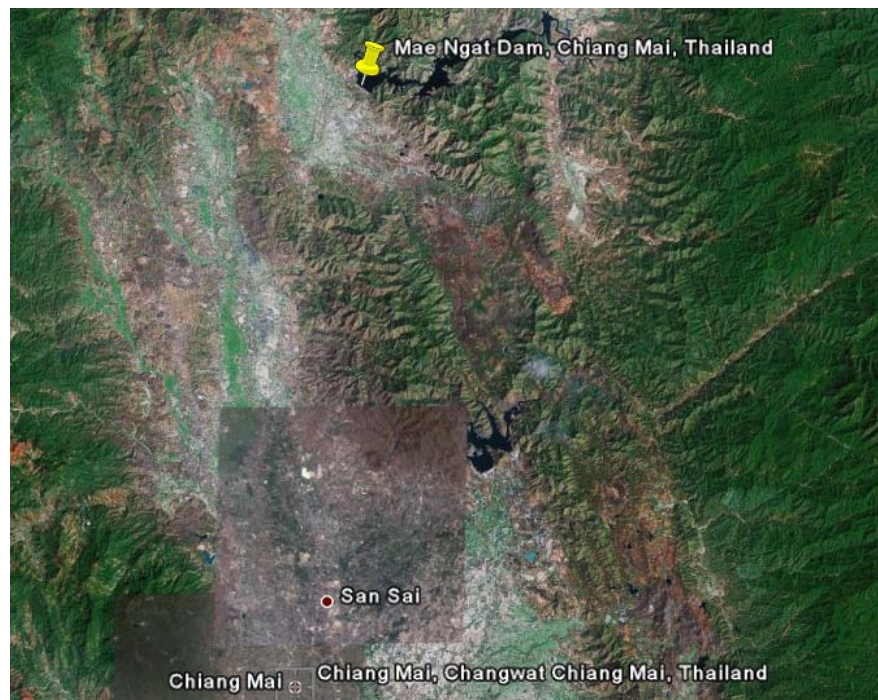

Figure 45. Mae Ngat Dam and Chiang Mai (From Google Earth)





Figure 46. Mae Ngat Dam area (From Google Earth)

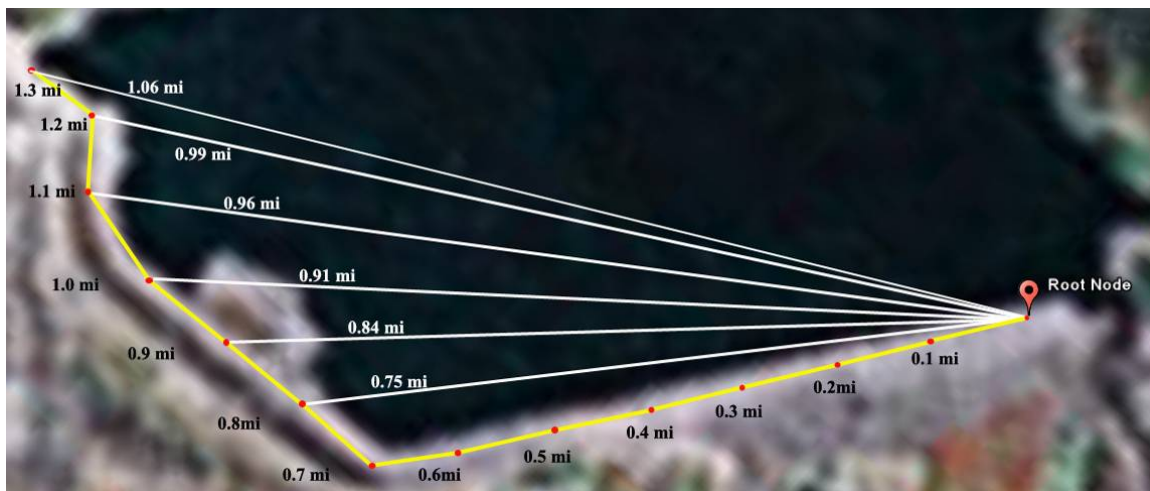

Figure 47. Mae Ngat Dam Test Distances (After Google Earth)

(Yellow lines are distances the AP traveled; white lines depict LOS distances)



Figure 48. Panoramic View of Mae Ngat Dam site

## 1. Method

The test methods employed here were the exact setup that was used during the pre Thailand tests outlined in section IV.B.1 of this document. Variations in conditions between the test sites included LOS connections over water at Mae Ngat Dam verses over land at FHL, as well as notably higher temperatures. Figure 49 depicts the physical test setup.



Figure 49. Test Setup, COASTS 2006,  
Mae Ngat Dam, Thailand

## 2. Test Results

The graph in Figure 50 summarizes the test results for all of the tests performed in the IEEE 802.11a standard. Combinations of the WiFi-Plus Multi-Polar antennas tested under this standard were the 5dBi to 5dBi with the domes facing each other, the 5dBi to 5dBi with the domes facing down (as recommended by the manufacturer), and the 13dBi to 13dBi sector antennas. Lack of data at a specific distance indicates the inability for the downstream AP to connect to the root node. The 'Traveled' distance denotes the distance

the vehicle carrying the downstream AP traveled, not the LOS distance between the APs; this is noted separately in the figures.

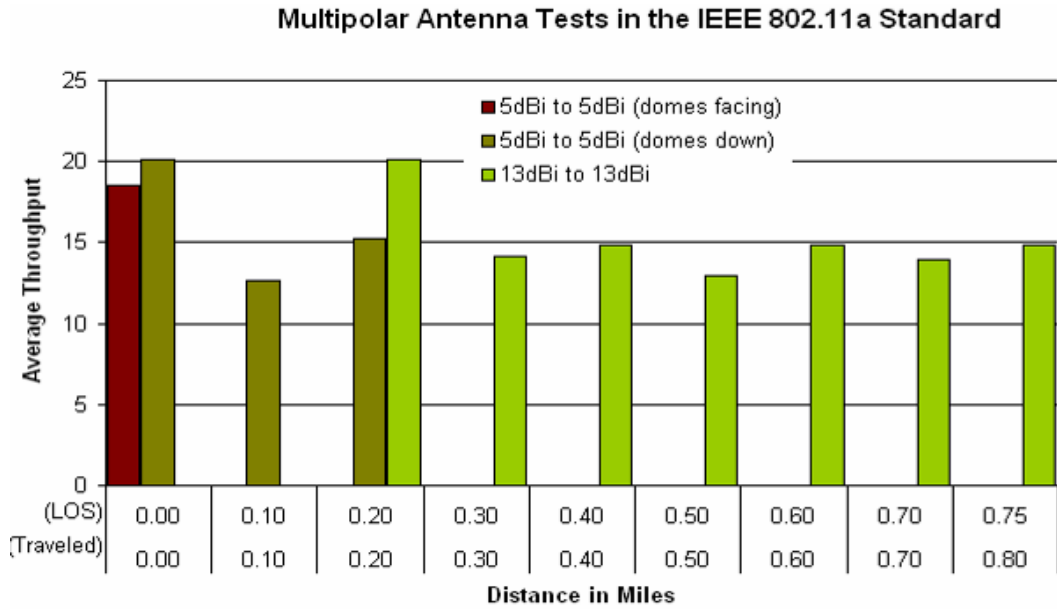

Figure 50. Multi-Polar Antenna Tests in the 802.11a Standard, Mae Ngat Dam

The next figure (Figure 51) summarizes the test results for the antennas tested in the IEEE 802.11g standard. The tested antenna configurations were 13dBi at the root node to 5dBi on the downstream AP, 5dBi on both nodes, and 13dBi on both nodes. As with the 802.11a tests, lack of data at a specific distance indicates the inability for the downstream AP to connect to the root node.

### Multipolar Antenna Tests in the IEEE 802.11g Standard

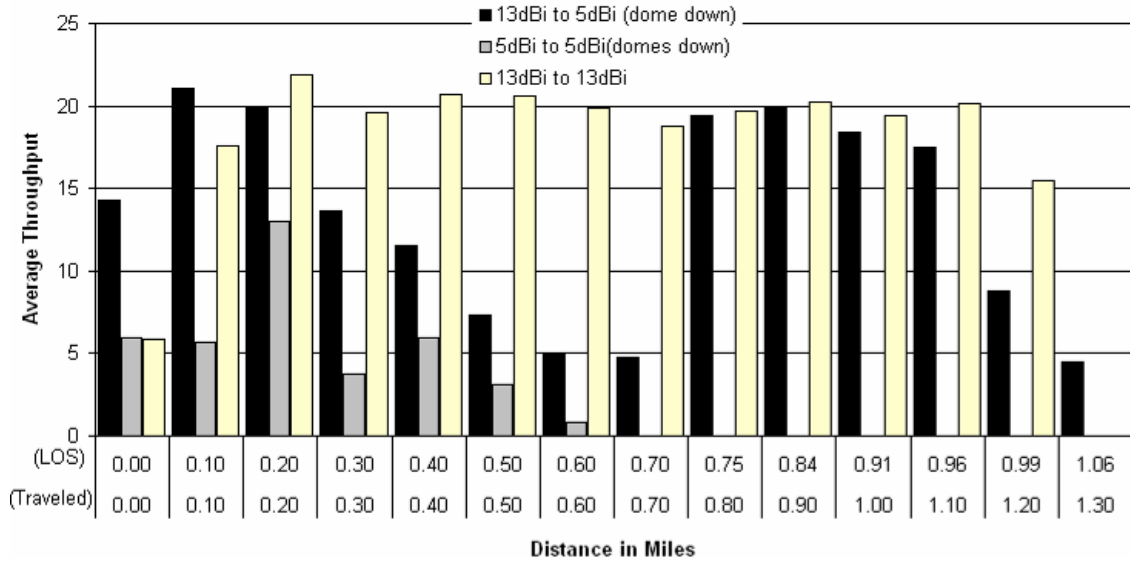

Figure 51. Multi-Polar Antenna Tests in the 802.11g Standard, Mae Ngat Dam

Figure 52 provides a side by side comparison of the IEEE 802.11a and 802.11g tests with the 5dBi Multi-Polar antenna configuration. A quick comparison of the two charts reveals that for distances up to 0.20 miles 802.11a offered a higher throughput rate, however, the nodes could not connect over 0.20 miles in the 802.11a standard. In the 802.11g standard the throughput was not as high as with the 802.11a however, the nodes were able to connect at a distance of 0.60 miles, far greater than the 802.11a standard afforded.

Comparison of the average throughput results from the 13dBi antennas between the two standards are provided in Figure 53. Unlike the 5dBi comparison, the 13dBi comparison chart reveals that the 802.11g standard offered greater throughput. As with the 5dBi tests the 13dBi 802.11g tests also allowed for connectivity between nodes at greater distances. For these tests, the max range was 0.99 miles.



**5dBi Multipolar Antenna Tests - Comparison of Average Throughput in the IEEE 802.11a and 802.11g Standard**

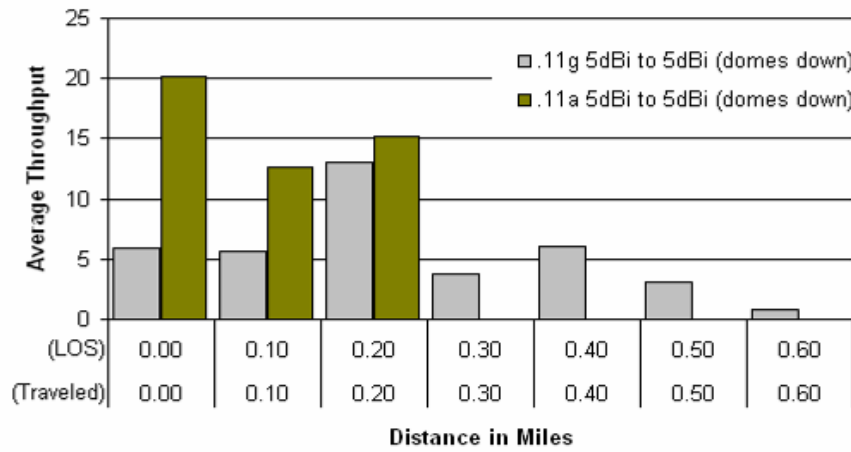

Figure 52. Comparison of Average Throughput for 5dBi Multi-Polar Antennas

**13dBi Multipolar Antenna Tests - Comparison of Average Throughput in the IEEE 802.11a and 802.11g Standard**

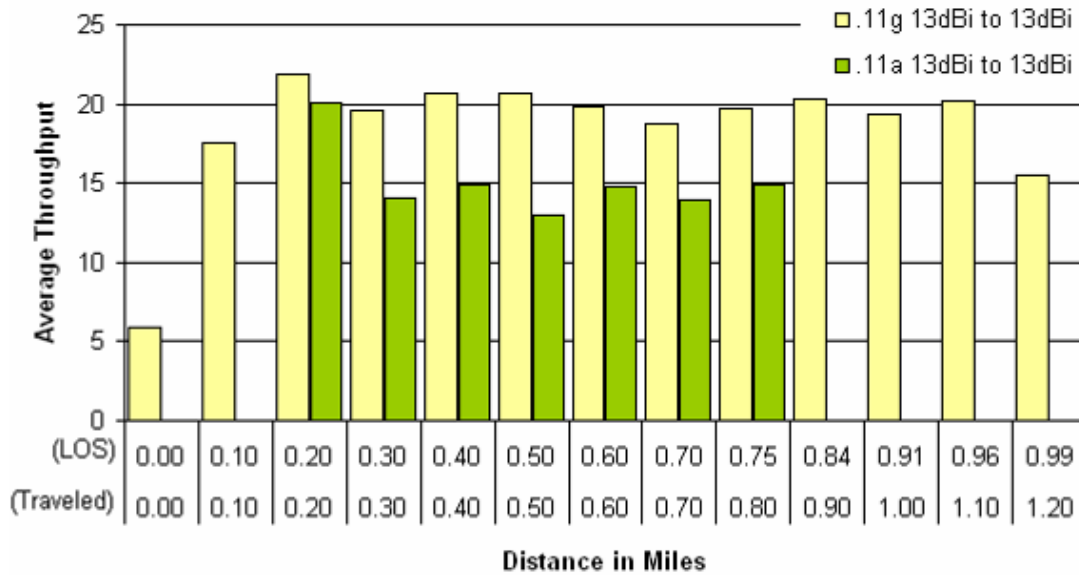

Figure 53. Comparison of Average Throughput for 13dBi Multi-Polar Antennas

Armed with the test results from the highly anticipated multi-polar antennas, in both the IEEE 802.11a and IEEE 802.11g standard, the team was convinced that these antennas would provide the most robust and reliable

connectivity for the network. This would hold true for not only the ground based portion of the network but also the ground to air portion as well, thanks to the wide coverage of the 13dBi sector antennas. Further, IEEE 802.11g compliant radios were deemed the radio of choice due to the ability to connect at greater distances than the IEEE 802.11a radios.

THIS PAGE INTENTIONALLY LEFT BLANK

## V. CONCLUSION

### A. ANTENNA TESTS

#### 1. Composite Analysis

Bringing it all together, Table 14 provides a close comparison of the FHL and Mae Ngat Dam tests. The green highlighted throughput numbers indicate the best throughput at each of the LOS test distances. Had the sole goal of antenna selection been achieving the greatest throughput, clearly the best solution would have been using the WiFi-Plus MP Tech 13dBi sector antennas throughout the network, as they performed the best. However, this was not the only goal for the network.

Antenna Tests Throughput Comparison

Test #	IEEE 802.11 Std	Antenna Config.	(FHL)	LOS Distance															
				(TH)	0.00	0.10	0.20	0.30	0.40	0.50	0.60	0.70	0.80	0.90	0.98				
FHL I	.11a	12dBi to 12dBi		0.22	21.32	17.35	20.29	18.59	4.35	17.40	16.09	18.54	17.48	16.16					
FHL II	.11a	8dBi to 8dBi		21.81	20.89	20.41	18.54	15.30	8.35	12.50	12.97	12.19	12.55	11.19					
TH II	.11a	5dBi to 5dBi		20.14	12.65	15.20													
TH III	.11a	13dBi to 13dBi				20.10	14.12	14.86	12.94	14.79	13.94	14.89							
TH IV	.11g	13dBi to 5dBi		14.27	21.04	19.91	13.69	11.58	7.33	5.01	4.80	19.44	19.97	18.39	17.48	8.78	4.53		
TH V	.11g	5dBi to 5dBi		5.95	5.67	13.04	3.79	5.99	3.11	0.80									
TH VI	.11g	13dBi to 13dBi		5.84	17.56	21.85	19.57	20.69	20.64	19.89	18.80	19.72	20.26	19.39	20.14	15.48			

Table 14. Antenna Test Throughput Comparison  
(Maximum Throughput Indicated by Green Highlights)

As outlined in the research questions for this thesis other key goals for the network included achieving the best range, acceptable throughput, light footprint, as well as ground to ground, ground to air, and air to air connectivity. The 13dBi sector antennas are great for fixed, ground based, point to point applications but will not work on the aerial platforms as directional control of the tethered balloon is not possible. For the ground to air

application we refer to Table 15 which compares the best throughput excluding the sector to sector antenna tests.

### Antenna Tests Throughput Comparison

Test #	IEEE 802.11 Std	Antenna Config.	(FHL)	LOS Distance													
				(TH)	0.00	0.10	0.20	0.30	0.40	0.50	0.60	0.70	0.80	0.90	0.98		
FHL I	.11a	12dBi to 12dBi		0.22	21.32	17.35	20.29	18.59	4.35	17.40	16.09	18.54	17.48	16.16			
FHL II	.11a	8dBi to 8dBi		21.81	20.89	20.41	18.54	15.30	8.35	12.50	12.97	12.19	12.55	11.19			
TH II	.11a	5dBi to 5dBi		20.14	12.65	15.20											
TH IV	.11g	13dBi to 5dBi		14.27	21.04	19.91	13.69	11.58	7.33	5.01	4.80	19.44	19.97	18.39	17.48	8.78	4.53
TH V	.11g	5dBi to 5dBi		5.95	5.67	13.04	3.79	5.99	3.11	0.80							

Table 15. Antenna Test Throughput Comparison  
 Excludes 13dBi to 13dBi Tests  
 (Maximum Throughput Indicated by Green Highlights)

Table 15 reveals that test FHL I, with the 12dBi to 12dBi antenna configuration in the IEEE 802.11a standard, out performed the other antenna configurations in most cases up to the 0.70 mile point. After 0.70 miles test TH IV, configured with the 13dBi on the root node and the 5dBi on the downstream AP in the IEEE 802.11g standard, showed remarkable throughput; so much so that it is suspect. Cross referencing those throughput figures with the receive signal strengths confirms that there was a higher signal strength at the 0.75 mile test than that at the 0.70 mile test (see Table 16). Though signal interference was highly unlikely due to the extremely remote location of the test site, antenna alignment of the 13dBi sector on the root node may have played a part in the lower readings for the 0.30 through 0.70 mile tests. This withstanding, if the tests were to be repeated, it is likely that this configuration would perform as well or better than the FHL I test with the 12dBi antennas configured in the IEEE 802.11a standard.

TH IV .11g 13dBi to 5dBi			
Test Route Distance (Miles)	LOS Distance	Signal Strength (dBm)	Avg Throughput
0.00	0.00	-64	14.265
0.10	0.10	-66	21.036
0.20	0.20	-69	19.911
0.30	0.30	-74	13.687
0.40	0.40	-77	11.578
0.50	0.50	-80	7.331
0.60	0.60	-86	5.006
0.70	0.70	-81	4.798
0.80	0.75	-74	19.441
0.90	0.84	-74	19.965
1.00	0.91	-75	18.387
1.10	0.96	-75	17.475
1.20	0.99	-80	8.779
1.30	1.06	-85	4.532

Table 16. Thailand Test IV 13dBi to 5dBi Signal Strength and Average Throughput

Not only does the 13dBi to 5dBi configuration in the IEEE 802.11g standard offer the highest throughput, it is also the best suited for the tethered balloon application. Although no throughput tests were performed a screen shot of the Mesh Dynamics Network Viewer application (see Figure 54) was taken while the COASTS 2006 network topology was being tested. Looking at the second line from the bottom in the figure shows that this node, set up with a MD4325GG model AP on a tethered balloon at an altitude of 1500 feet, had an uplink and downlink connection speed of 11Mbps (the node icon with the -80dBm signal strength). While this is not spectacular it proves that this antenna combination works well for this application. Figure 55 depicts the tethered balloon node as deployed during the Thailand field experiment. Further evidence that this antenna configuration works well is in video format that was recorded from the computer screen during a test run of the COASTS 2006 scenario.

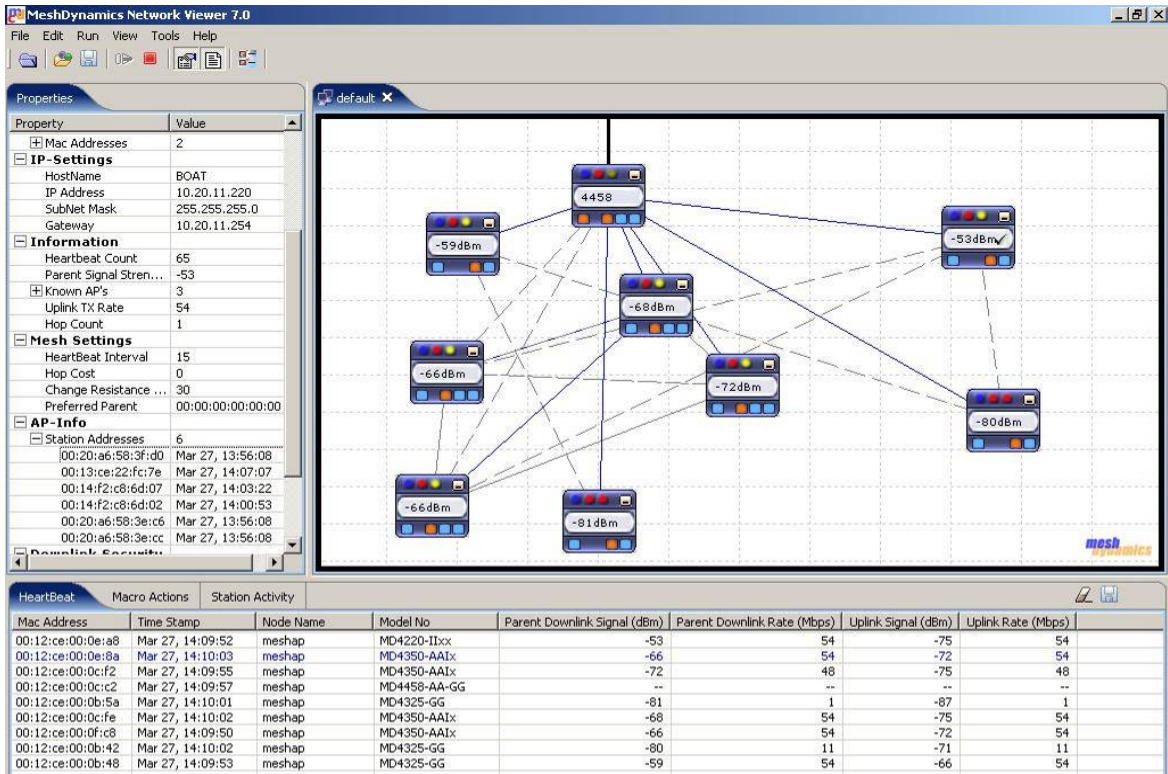

Figure 54. Mesh Dynamics Network Viewer Application  
 March 27, 2006, Tethered Balloon at 1500' and 11Mbps



Figure 55. Aerial Payload as Deployed in the  
 COASTS 2006 Field Experiment

Looking again at Figure 54, the root node, depicted by the solid black line connected to the top of the icon, is the parent link to the tethered balloon node. The root node, as configured during the field experiment, is depicted in Figure 55. The root node was configured with two 2.4GHz 400mW Ubiquity radios and 13dBi MP Tech sector antennas to allow connectivity to both Balloon 1 and Node 4, which was located at the far end of the dam face. The third radio in the root node was 5.8GHz, 400mW, allowing connectivity for the other 5.8GHz nodes in the mesh. Table 17 details the setup of all the nodes deployed during the Thailand Field Experiment in March 2006.



Figure 56. Root Node, Thailand Field Experiment  
COASTS 2006



### Thailand Field Experiment Node Details

	Freq	Antennas	Radios
<b>Root</b>			
<b>AAI</b>	5.8	Unused	400mW
	5.8	13dBi MP Sec	400mW
	2.4	13dBi MP Sec	400mW
	2.4	13dBi MP Sec	400mW
<b>Camera node 1</b>			
<b>AAI</b>	5.8	8dBi Super	50mW
	5.8	8dBi Super	50mW
	2.4	5dBi MP	50mW
<b>Node 2</b>			
<b>AAI</b>	5.8	super sectors	400mW
	5.8	super sectors	400mW
	2.4	5dBi MP	400mW
<b>Balloon 1</b>			
<b>GGs</b>	5.8	5dBi MP	400mW
	5.8	5dBi MP	400mW
	2.4	9dBi Super	400mW
<b>Camera node 2</b>			
<b>AAI</b>	5.8	8dBi Super	50mW
	5.8	8dBi Super	50mW
	2.4	5dBi MP	50mW
<b>Node 3</b>			
<b>AAI</b>	5.8	super sector	400mW
	5.8	nothing downstream	400mW
	2.4	5dBi MP	400mW
<b>Camera node 3</b>			
<b>AAI</b>	5.8	super sector spdn6f	50mW
	5.8	8dBi Super	50mW
	2.4	5dBi MP	50mW
<b>Node 4</b>			
<b>GGs</b>	2.4	13dBi Sector	400mW
	2.4	5dBi MP	400mW
	2.4	9dBi Super	400mW

Table 17. Thailand Field Experiment Node Details as Deployed

Though throughput testing revealed the optimum radio and antenna mix was 2.4GHz with multi-polar antennas the team did not have enough 2.4GHz radios on hand to implement the findings in the network at the time. Based on the findings of this research, the recommendation for the COASTS May 2006 demonstration network were as is detailed in Table 18.

**Recommended Network Implementation  
Thailand Demonstration, May 2006**

	Freq	Use	Antennas	Radios	400mW 2.4	5dBi MP	13dBi MP
					Radios Required	Antennas Required	Antennas Required
<b>Root</b>							
<b>GIII</b>	2.4	Downstream	13dBi MP Sec	400mW	1		1
	2.4	Service1 Local	5dBi MP	400mW	1	1	
	2.4	Service2 Water	13dBi MP Sec	400mW	1		1
	2.4	Service3 Balloons	13dBi MP Sec	400mW	1		1
<b>Camera node 1</b>							
<b>GGII</b>	2.4	Upstream	5dBi MP	400mW	1	1	
	2.4	Downstream	5dBi MP	400mW	1	1	
	2.4	Service1 Local	5dBi MP	400mW	1	1	
	2.4	Service2 Valley	13dBi MP Sec	400mW	1		1
<b>Balloon 1</b>							
<b>GGs</b>	2.4	Upstream	5dBi MP	400mW	1	1	
	2.4	Downstream/srvc	5dBi MP	400mW	1	1	
	2.4	Scanning	9dBi Superpass	50mW			
<b>Node 2</b>							
<b>GGII</b>	2.4	Upstream	5dBi MP	400mW	1	1	
	2.4	Downstream	5dBi MP	400mW	1	1	
	2.4	Service1 Local	5dBi MP	400mW	1	1	
	2.4	Service2 Water	13dBi MP Sec	400mW	1		1
<b>Balloon 2</b>							
<b>GGs</b>	2.4	Upstream	5dBi MP	400mW	1	1	
	2.4	Downstream/srvc	5dBi MP	400mW	1	1	
	2.4	Scanning	9dBi Superpass	50mW			
<b>Camera node 2</b>							
<b>GGII</b>	2.4	Upstream	5dBi MP	400mW	1	1	
	2.4	Downstream	5dBi MP	400mW	1	1	
	2.4	Service1 Local	5dBi MP	400mW	1	1	
	2.4	Service2 Valley	13dBi MP Sec	400mW	1		1
<b>Node 3</b>							
<b>GGII</b>	2.4	Upstream	5dBi MP	400mW	1	1	
	2.4	Downstream	5dBi MP	400mW	1	1	
	2.4	Service1 Local	5dBi MP	400mW	1	1	
	2.4	Service2 Water	13dBi MP Sec	400mW	1		1
<b>Balloon 3</b>							
<b>GGs</b>	2.4	Upstream	5dBi MP	400mW	1	1	
	2.4	Downstream/srvc	5dBi MP	400mW	1		
	2.4	Scanning	9dBi Superpass	50mW			
<b>Camera node 3</b>							
<b>GGII</b>	2.4	Upstream	5dBi MP	400mW	1	1	
	2.4	Downstream	5dBi MP	400mW	1	1	
	2.4	Service1 Local	5dBi MP	400mW	1	1	
	2.4	Service2 Valley	13dBi MP Sec	400mW	1		1
<b>Node 4</b>							
<b>GGII</b>	2.4	Upstream	13dBi MP Sec	400mW	1		1
	2.4	Service1 Local	5dBi MP	400mW	1	1	
	2.4	Service2 Water	13dBi MP Sec	400mW	1		1
	2.4	Service3 Balloons	13dBi MP Sec	400mW	1		1
<b>Boat</b>							
<b>GGs</b>	2.4	Upstream	5dBi MP	400mW	1	1	
	2.4	Downstream/srvc	5dBi MP	400mW	1	1	
	2.4	Scanning	9dBi Superpass	50mW			

Table 18. Recommended Network Implementation  
Thailand Demonstration, May 2006

## 2. Anechoic Chamber

In an effort to better understand the characteristics of the WiFi-Plus Multi-Polar antennas, further research was conducted. Through the use of the NPS Antenna Laboratory's anechoic chamber (see Figure 57), azimuth and elevation charts were created providing a higher resolution plot of exactly how the electromagnetic waves propagate from these antennas in their intended frequency ranges. Figures 58 through 65 depict wave propagation from both the 5dBi MP Tech and the 13dBi MP Tech Single Sector antenna in the vertical and horizontal planes for each of the 2.4GHz and the 5.8GHz bands. This data will allow future researchers to integrate the antennas into the network with better understanding for improved results.

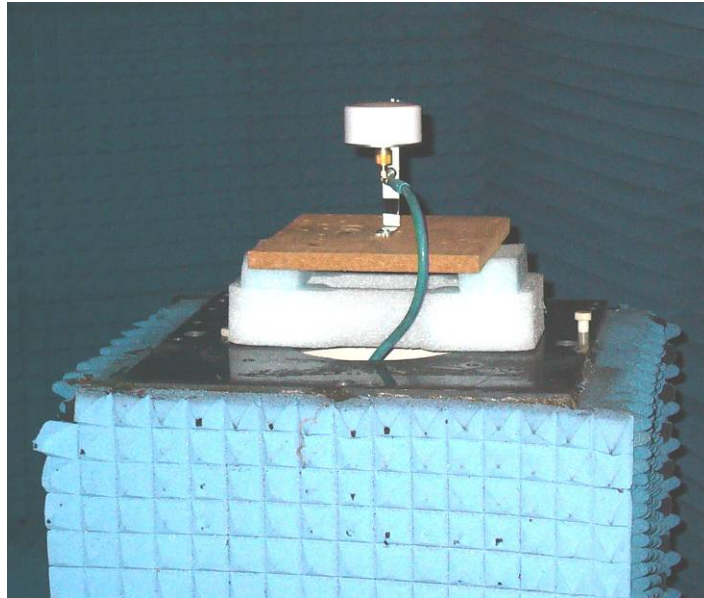

Figure 57. WiFi-Plus MP Tech 5dBi Antenna in the Naval Postgraduate School Anechoic Chamber

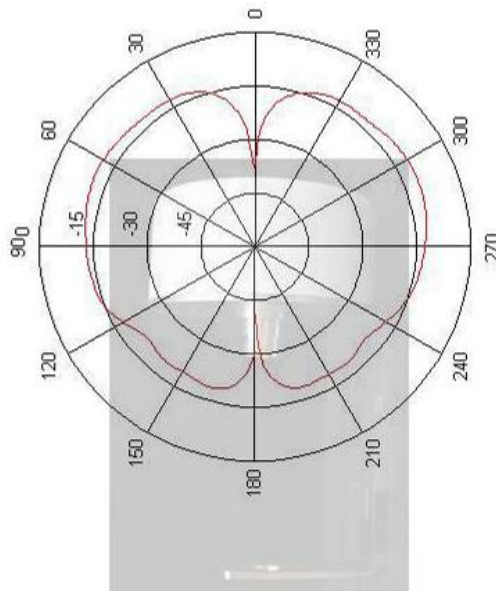

Figure 58. WiFi-Plus MP Tech 5dBi,  
H-Plane at 2.4GHz

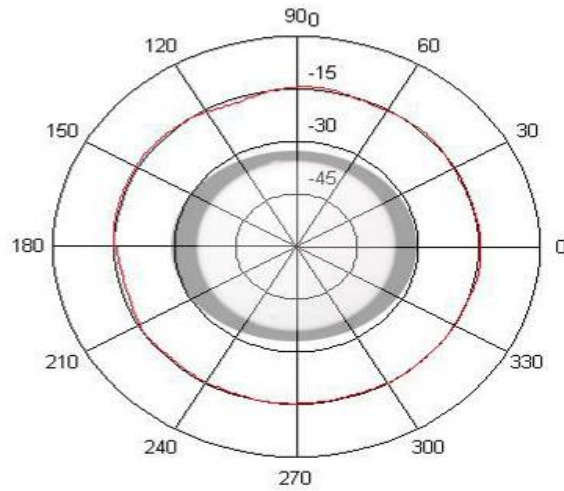

Figure 59. WiFi-Plus MP Tech 5dBi,  
E-Plane at 2.4GHz

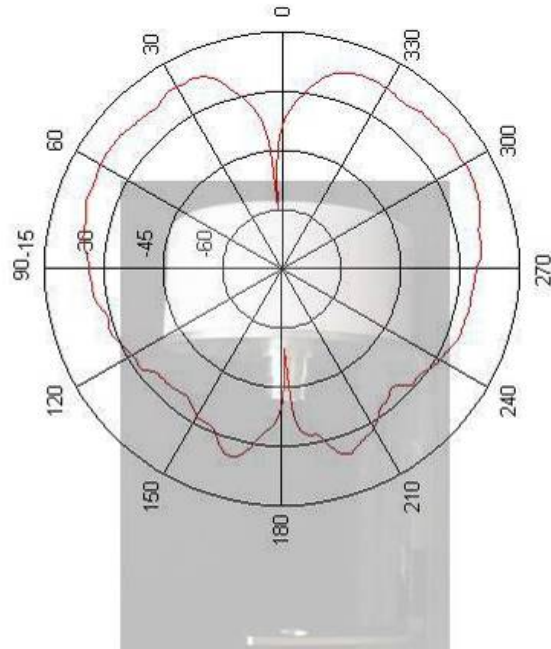

Figure 60. WiFi-Plus MP Tech 5dBi, H-Plane at 5.8GHz

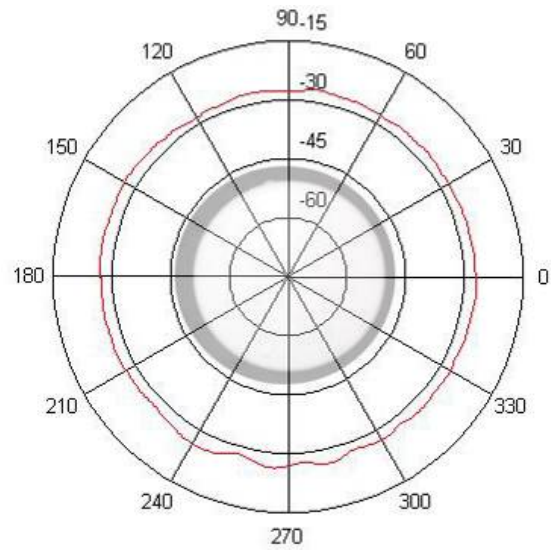

Figure 61. WiFi-Plus MP Tech 5dBi, E-Plane at 5.8GHz

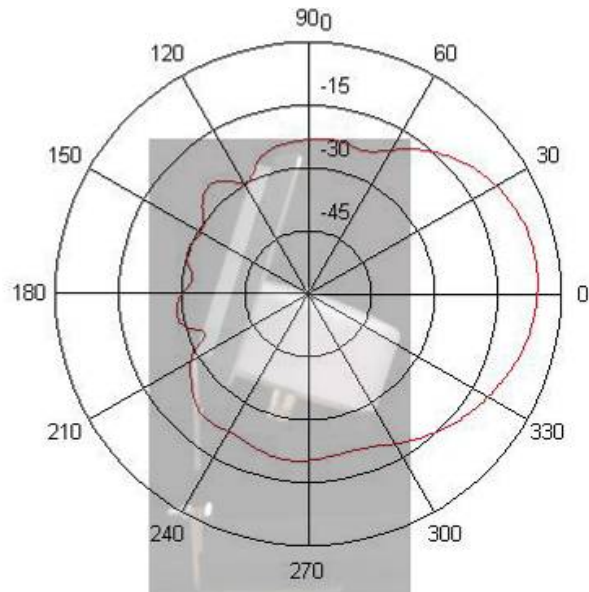

Figure 62. WiFi-Plus MP Tech 13dBi Single Sector, H-Plane at 2.4GHz

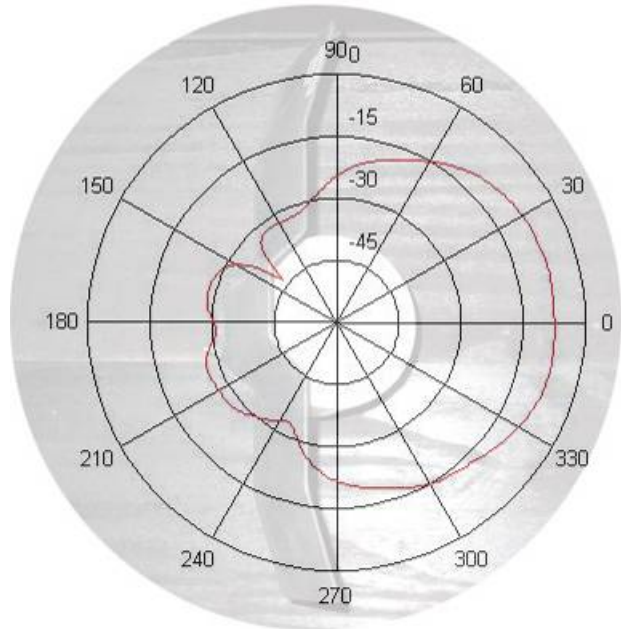

Figure 63. WiFi-Plus MP Tech 13dBi Single Sector, E-Plane at 2.4GHz

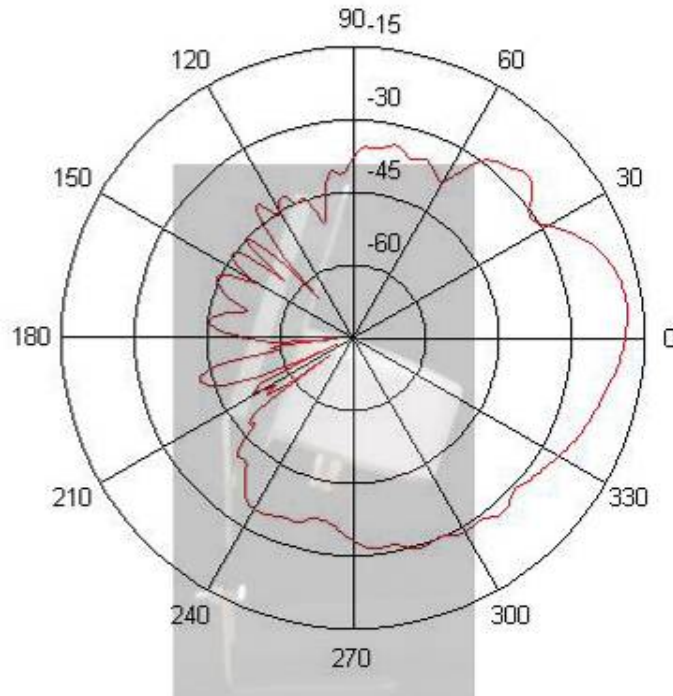

Figure 64. WiFi-Plus MP Tech 13dBi Single Sector, H-Plane at 5.8GHz

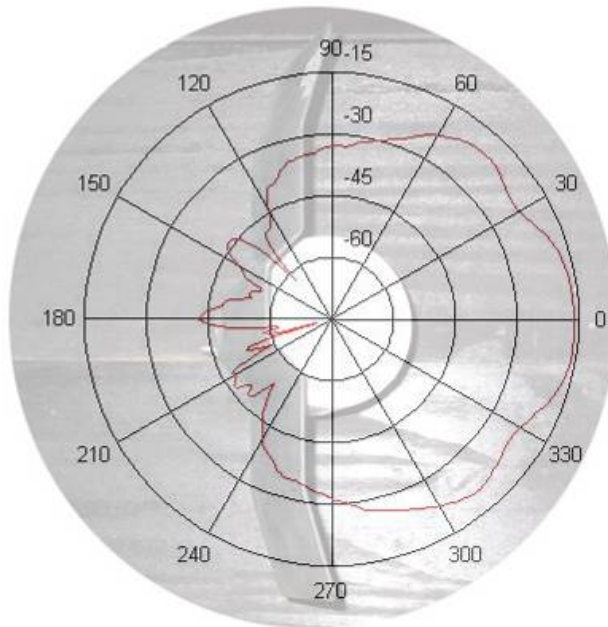

Figure 65. WiFi-Plus MP Tech 13dBi Single Sector, E-Plane at 5.8GHz

## **B. FUTURE WORK**

Though a solid recommendation was achieved through this research, there are undoubtedly more areas to pursue. The most pressing for the team is greater study of the ground to air portion of the network. Rigorous throughput testing of ground to air links would provide a solid basis for which to build on in this area. Further development and testing of more stable payload solutions would also benefit the COASTS research. Secondly, testing of the WiFi-Plus MP Tech antennas in RF harsh environments such as dense vegetation would further this research and the validity of the manufacturer claims. Testing other multi-polar antennas, such as the WiFi-Plus 2dBi Laptop/Personal Bullet Antenna (WiFi-Plus) for mobile users verses the imbedded wireless card antennas would also be of interest. Another branch to this research would be to conduct load testing of the Mesh Dynamics APs using the recommended antenna configuration. Using IxChariot one could model a busy network and monitor how well it performs. Yet another suggestion for further research is looking at the state-of-the-art for IEEE 802.11n products. This would provide a view into the next generation of wireless technology and recommendation as to COASTS interest into pursuing it.



THIS PAGE INTENTIONALLY LEFT BLANK

## LIST OF REFERENCES

- Afar Communications, Inc. RF Link Budget Calculator.  
Retrieved February 2006, from <http://www.afar.net/rf-link-budget-calculator/>
- "Antenna Letter." Rocky Mountain VHF+. Retrieved February 2006, from <http://www.qsl.net/rmvhf/antenna-letter.html>
- Coalition Operating Area Surveillance and Targeting System (COASTS) Thailand Field Experiment (May 2005) After Action Report. Naval Postgraduate School, Monterey, California.
- Coalition Operating Area Surveillance and Targeting System (COASTS) Thailand Field Experiment (May 2006) Concept of Operations. Naval Postgraduate School, Monterey, California.
- Fordahl, Matthew. "Geek cavalries turn post-Katrina landscape into wireless lab." 4 October 2005. *Free Press*. Retrieved April 2007, from <http://www.freepress.net/news/11684>
- Google Earth. Retrieved from <http://earth.google.com>
- Hyperlink Technologies. Hyperlink Technologies Antenna Specifications. Retrieved March 2006, from <http://www.hyperlinktech.com>
- Lee, Christopher R. "Aerial Command and Control Utilizing Wireless Meshed Networks in Support of Joint Tactical Coalition Operations." September 2005. Master's Thesis. Naval Postgraduate School, Monterey, California.
- "MP - OMNI 5 dBi 360 Degree Coverage Indoors or Out." WiFi-Plus [Electronic Version]. Retrieved February 2005, from <http://www.wifi-plus.com/images/specOmni.pdf>
- "MP-Tech. 'Single Sector' Antenna WFP0200508 120 Degrees Coverage." WiFi-Plus [Electronic Version]. Retrieved July 2007, from <http://www.wifi-plus.com/images/WFP0200508specs.pdf>

Operations Order 04-05 (Thailand Rehearsal). 19 April 2005.  
Planet3 Wireless. Certified Wireless Network Administrator  
Official Study Guide. 3rd ed. New York: McGraw Hill,  
2005.

Rajant. "Comparisons." Rajant Technologies. Retrieved March  
2006, from <http://www.rajant.com/comparisons.htm>

RF Link Budget Calculator. Afar Communications. Retrieved  
February 2006, from [http://www.afar.net/RF\\_calc.htm](http://www.afar.net/RF_calc.htm)

"Specifications." Mini-box.com. Retrieved March 2006, from  
[http://www.mini-box.com/s.nl/sc.8/category.87/it.A/  
id.331/.f](http://www.mini-box.com/s.nl/sc.8/category.87/it.A/id.331/.f)

Superpass. SuperPass Antenna Specifications. Retrieved  
March 2006, from [www.superpass.com](http://www.superpass.com)

SuperRange2 Specifications. Ubiquity Networks. Retrieved  
March 2006, from [http://www.ubnt.com/supper\\_range.php4](http://www.ubnt.com/supper_range.php4)

SuperRange5 Specifications. Ubiquity Networks. Retrieved  
March 2006, from [http://www.ubnt.com/supper\\_range5.php4](http://www.ubnt.com/supper_range5.php4)

"Why Structured Mesh." Mesh Dynamics. Retrieved March 2006,  
from <http://www.meshdynamics.com/WhyStructured Mesh.html>

WiFi-Plus. Retrieved March 2006, from [http://www.wifi-  
plus.com](http://www.wifi-plus.com)

"WiFi-Plus MP Tech Explained." Retrieved March 2006, from  
<http://www.wifi-plus.com/images/MP-Tech.pdf>

## APPENDIX A. POWER CABLE SCHEMATIC

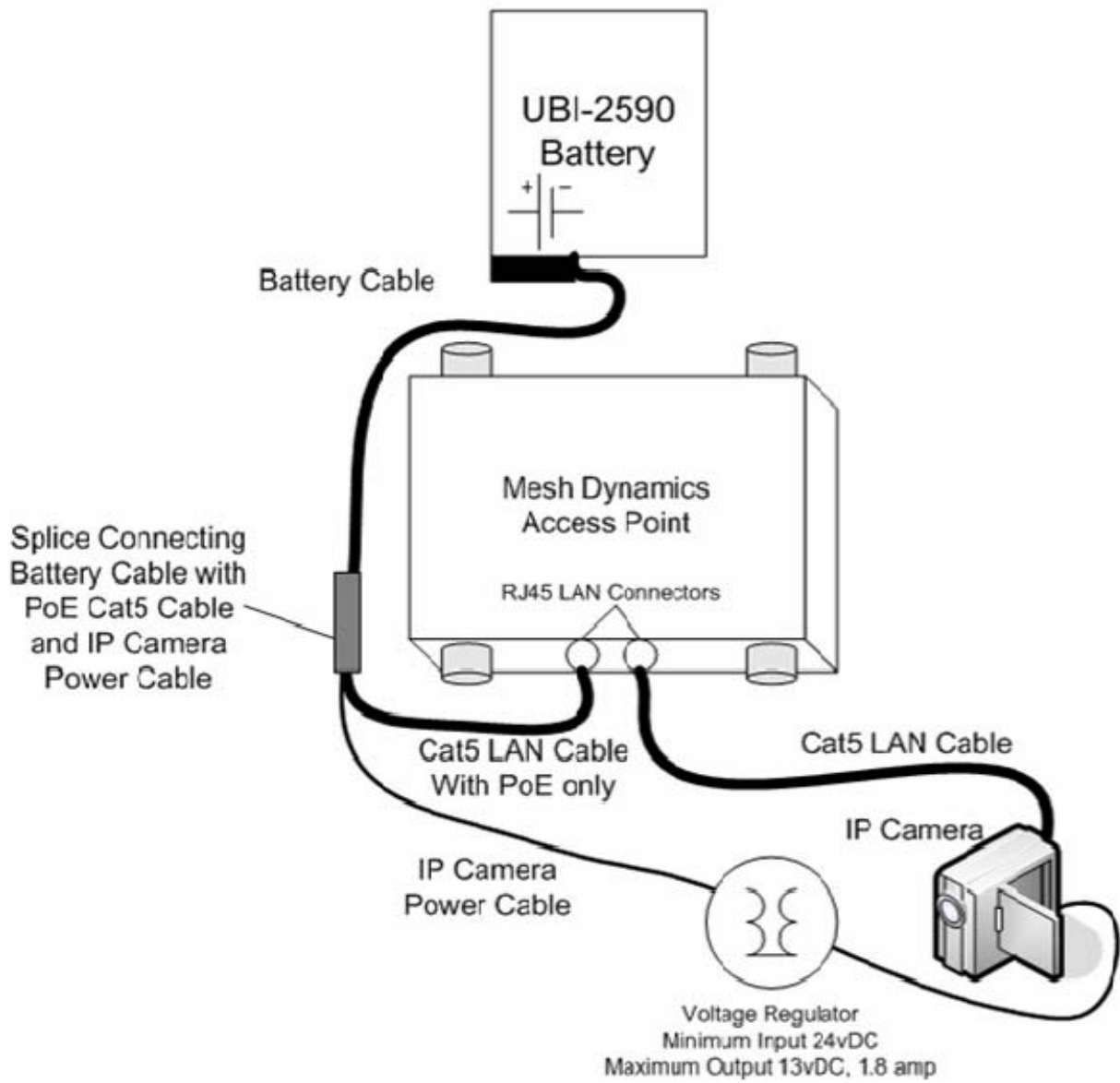

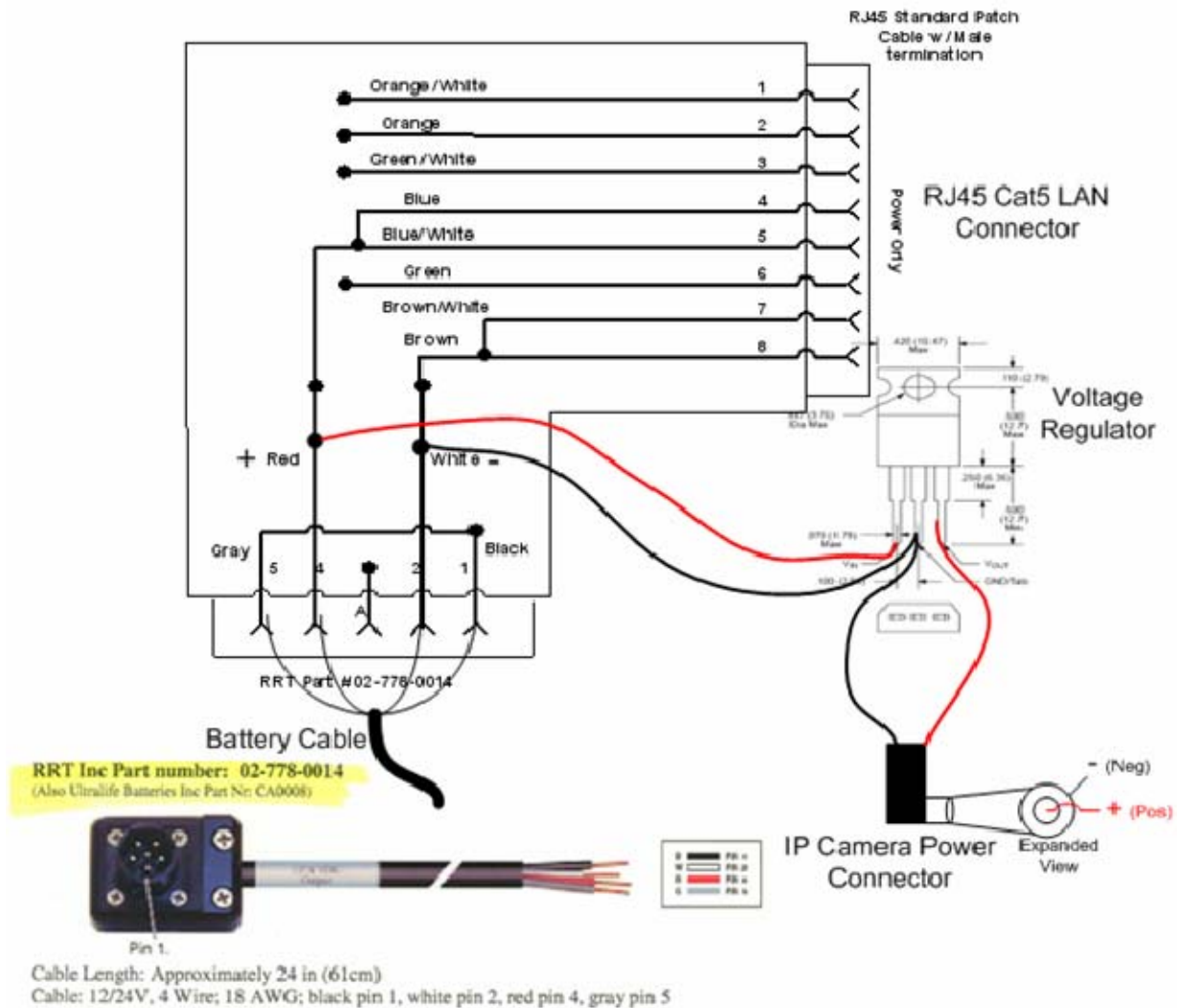

**Power Only Configuration:**

**RRT Cable**

- Pins 1&5 Solder Black / Grey wires together
- Pin 4 Red (+)
- Pin 2 White (-)

**RJ45 Cable**

- Cut to desired length, use one end of cable
- Pins 4&5 Solder blue and blue/white wire together (+)
- Pins 7&8 Solder brown/white and brown wire together (-)
- Trim wire on other pins, do not connect.

**IP Camera Power Cable**

- Connect positive (+) wire from IP camera connector to RRT pin 4 Red (+)
- Connect negative (-) wire from IP camera connector to RRT pin 2 White (-)

**Connection**

- Connect RJ45 Pins 4&5 Power + to RRT pin 4 Red (+)
- Connect RJ45 Pins 7&8 Power - to RRT pin 2 White (-)

**APPENDIX B. ANTENNA TEST DATA**

Test #	IEEE 802.11 Std	Root Node Antenna	Dwn Stream AP Antenna	Antenna Orientation	Test Route Distance (Miles)	LOS Distance	Signal Strength (dBm)	Throughput (Mbps)			AP Board Temp °F	Air Temp °F
								Min	Max	Final Avg		
PHL I .11a	12dBi	12dBi	12dBi	Vertical Polarization	0.00	0.00				0.222	77.0	52.0
PHL I .11a	12dBi	12dBi	12dBi	Vertical Polarization	0.10	0.10				21.319	77.0	53.0
PHL I .11a	12dBi	12dBi	12dBi	Vertical Polarization	0.20	0.20				17.347	77.0	53.0
PHL I .11a	12dBi	12dBi	12dBi	Vertical Polarization	0.30	0.30				20.290	77.0	53.0
PHL I .11a	12dBi	12dBi	12dBi	Vertical Polarization	0.40	0.40				18.590	77.0	54.0
PHL I .11a	12dBi	12dBi	12dBi	Vertical Polarization	0.50	0.50				4.345	77.0	54.0
PHL I .11a	12dBi	12dBi	12dBi	Vertical Polarization	0.60	0.60				17.395	77.0	54.0
PHL I .11a	12dBi	12dBi	12dBi	Vertical Polarization	0.70	0.70				16.092	77.0	55.0
PHL I .11a	12dBi	12dBi	12dBi	Vertical Polarization	0.80	0.80				18.540	77.0	55.0
PHL I .11a	12dBi	12dBi	12dBi	Vertical Polarization	0.90	0.90				17.481	77.0	55.0
PHL I .11a	12dBi	12dBi	12dBi	Vertical Polarization	0.98	0.98				16.162		
PHL II .11a	8dBi	8dBi	8dBi	Vertical Polarization	0.00	0.00				21.810	86.0	59.0
PHL II .11a	8dBi	8dBi	8dBi	Vertical Polarization	0.10	0.10				20.889	84.2	59.0
PHL II .11a	8dBi	8dBi	8dBi	Vertical Polarization	0.20	0.20				20.406	84.2	59.0
PHL II .11a	8dBi	8dBi	8dBi	Vertical Polarization	0.30	0.30				18.537	84.2	59.0
PHL II .11a	8dBi	8dBi	8dBi	Vertical Polarization	0.40	0.40				15.299	84.2	58.0
PHL II .11a	8dBi	8dBi	8dBi	Vertical Polarization	0.50	0.50				8.352	82.4	58.0
PHL II .11a	8dBi	8dBi	8dBi	Vertical Polarization	0.60	0.60				12.500	82.4	58.0
PHL II .11a	8dBi	8dBi	8dBi	Vertical Polarization	0.70	0.70				12.965	82.4	58.0
PHL II .11a	8dBi	8dBi	8dBi	Vertical Polarization	0.80	0.80				12.193	80.6	57.0
PHL II .11a	8dBi	8dBi	8dBi	Vertical Polarization	0.90	0.90				12.545	78.8	57.0
PHL II .11a	8dBi	8dBi	8dBi	Vertical Polarization	0.90	0.98				11.189		
TH I .11a	5dBi	5dBi	5dBi	Domes facing	0.00	0.00	-53	2.658	22.857	18.527	113	83.0
TH II .11a	5dBi	5dBi	5dBi	Domes pointing down	0.00	0.00	-40	16.667	22.857	20.136	109.4	97.0
TH II .11a	5dBi	5dBi	5dBi	Domes pointing down	0.10	0.10	-70	1.023	19.048	12.646	113	84.6
TH II .11a	5dBi	5dBi	5dBi	Domes pointing down	0.20	0.20	-80	12.121	17.391	15.198	104	80.0
TH III .11a	13dBi	13dBi	13dBi	Per Manu. Specs.	0.00	0.00	-31				113	89.5
TH III .11a	13dBi	13dBi	13dBi	Per Manu. Specs.	0.10	0.10	-59				113	84.0
TH III .11a	13dBi	13dBi	13dBi	Per Manu. Specs.	0.20	0.20	-71	18.182	22.222	20.101	113	85.0
TH III .11a	13dBi	13dBi	13dBi	Per Manu. Specs.	0.30	0.30	-76	2.447	19.048	14.117	113	86.0
TH III .11a	13dBi	13dBi	13dBi	Per Manu. Specs.	0.40	0.40	-78	2.100	19.048	14.869	113	88.0
TH III .11a	13dBi	13dBi	13dBi	Per Manu. Specs.	0.50	0.50	-79	0.755	18.605	12.935	113	89.0
TH III .11a	13dBi	13dBi	13dBi	Per Manu. Specs.	0.60	0.60	-80	2.299	18.605	14.793	113	90.0
TH III .11a	13dBi	13dBi	13dBi	Per Manu. Specs.	0.70	0.70	-77	1.223	18.605	13.942	113	95.7
TH III .11a	13dBi	13dBi	13dBi	Per Manu. Specs.	0.80	0.75	-80	3.042	17.778	14.889	113	94.6
TH IV .11g	13dBi	5dBi	5dBi	13dBi per spec; 5dBi dome down	0.00	0.00	-64	2.768	21.622	14.265	105.8	73.5
TH IV .11g	13dBi	5dBi	5dBi	13dBi per spec; 5dBi dome down	0.10	0.10	-66	18.182	23.530	21.036	105.8	73.8
TH IV .11g	13dBi	5dBi	5dBi	13dBi per spec; 5dBi dome down	0.20	0.20	-69	16.000	22.857	19.911	105.8	73.9

Test #	IEEE 802.11 Std	Root Node Antenna	Dwn Stream AP Antenna	Antenna Orientation	Test Route Distance (Miles)	Signal Strength (dBm)	Throughput (Mbps)			AP Board Temp °F	Air Temp °F	
							LOS Distance	Min	Max			Final Avg
TH IV	.11g	13dBi	5dBi	13dBi per spec; 5dBi dome down	0.30	-74	0.30	2.878	18.605	13.687	105.8	73.9
TH IV	.11g	13dBi	5dBi	13dBi per spec; 5dBi dome down	0.40	-77	0.40	0.406	18.605	11.578	105.8	74.1
TH IV	.11g	13dBi	5dBi	13dBi per spec; 5dBi dome down	0.50	-80	0.50	3.902	9.195	7.331	105.8	74.5
TH IV	.11g	13dBi	5dBi	13dBi per spec; 5dBi dome down	0.60	-86	0.60	0.708	6.612	5.006	113	74.9
TH IV	.11g	13dBi	5dBi	13dBi per spec; 5dBi dome down	0.70	-81	0.70	3.636	8.421	4.798	113	75.0
TH IV	.11g	13dBi	5dBi	13dBi per spec; 5dBi dome down	0.80	-74	0.75	17.021	21.622	19.441	113	75.0
TH IV	.11g	13dBi	5dBi	13dBi per spec; 5dBi dome down	0.90	-74	0.84	15.686	22.857	19.965	113	76.0
TH IV	.11g	13dBi	5dBi	13dBi per spec; 5dBi dome down	1.00	-75	0.91	16.000	21.053	18.387	113	76.1
TH IV	.11g	13dBi	5dBi	13dBi per spec; 5dBi dome down	1.10	-75	0.96	4.520	21.053	17.475	111.2	76.1
TH IV	.11g	13dBi	5dBi	13dBi per spec; 5dBi dome down	1.20	-80	0.99	0.256	17.391	8.779	111.2	76.6
TH IV	.11g	13dBi	5dBi	13dBi per spec; 5dBi dome down	1.30	-85	1.06	1.311	5.797	4.532	111.2	77.9
TH IV	.11g	13dBi	5dBi	13dBi per spec; 5dBi dome down	1.4 - 0	0.85 - 0		1.797	22.637	12.535		79.0
TH V	.11g	5dBi	5dBi	Domes pointing down	0.00	-56	0.00	1.856	7.018	5.952	104	69.8
TH V	.11g	5dBi	5dBi	Domes pointing down	0.10	-57	0.10	1.295	8.333	5.671	105.8	70.5
TH V	.11g	5dBi	5dBi	Domes pointing down	0.20	-76	0.20	1.135	19.048	13.040	105.8	70.7
TH V	.11g	5dBi	5dBi	Domes pointing down	0.30	-81	0.30	0.282	6.612	3.786	107.6	70.8
TH V	.11g	5dBi	5dBi	Domes pointing down	0.40	-84	0.40	2.326	6.504	5.994	107.6	71.0
TH V	.11g	5dBi	5dBi	Domes pointing down	0.50	-87	0.50	1.127	5.128	3.114	105.8	71.2
TH V	.11g	5dBi	5dBi	Domes pointing down	0.60	-92	0.60	0.380	2.878	0.803	104	71.3
TH VI	.11g	13dBi	13dBi	Per Manu. Specs.	0.00	-35	0.00	0.724	6.897	5.843	111.2	81.2
TH VI	.11g	13dBi	13dBi	Per Manu. Specs.	0.10	-47	0.10	12.903	22.857	17.563	111.2	81.4
TH VI	.11g	13dBi	13dBi	Per Manu. Specs.	0.20	-51	0.20	19.512	24.243	21.852	111.2	81.5
TH VI	.11g	13dBi	13dBi	Per Manu. Specs.	0.30	-57	0.30	3.265	24.243	19.574	111.2	81.7
TH VI	.11g	13dBi	13dBi	Per Manu. Specs.	0.40	-61	0.40	5.634	23.530	20.693	111.2	82.0
TH VI	.11g	13dBi	13dBi	Per Manu. Specs.	0.50	-63	0.50	16.667	23.530	20.640	113	82.1
TH VI	.11g	13dBi	13dBi	Per Manu. Specs.	0.60	-67	0.60	6.897	22.857	19.886	113	82.3
TH VI	.11g	13dBi	13dBi	Per Manu. Specs.	0.70	-71	0.70	3.704	23.530	18.797	113	82.5
TH VI	.11g	13dBi	13dBi	Per Manu. Specs.	0.80	-72	0.75	5.882	22.857	19.719	111.2	82.3
TH VI	.11g	13dBi	13dBi	Per Manu. Specs.	0.90	-63	0.84	14.286	23.530	20.258	111.2	82.4
TH VI	.11g	13dBi	13dBi	Per Manu. Specs.	1.00	-65	0.91	3.252	22.857	19.394	111.2	82.9
TH VI	.11g	13dBi	13dBi	Per Manu. Specs.	1.10	-71	0.96	17.021	22.857	20.141	111.2	83.0
TH VI	.11g	13dBi	13dBi	Per Manu. Specs.	1.20	-73	0.99	2.920	22.222	15.483	111.2	83.7

## INITIAL DISTRIBUTION LIST

1. Defense Technical Information Center  
Ft. Belvoir, Virginia
2. Dudley Knox Library  
Naval Postgraduate School  
Monterey, California
3. Mr. James Ehlert  
Naval Postgraduate School  
Monterey, California
4. LtCol Karl Pfeiffer  
Naval Postgraduate School  
Monterey, California
5. Rita Painter  
Naval Postgraduate School  
Monterey, California
6. Dr. Bruce Whalen  
SPAWARSYSCEN  
San Diego, California
7. Thomas Latta  
Space and Naval Warfare Systems Command  
San Diego, California
8. Dr. Dan C Boger  
Naval Postgraduate School  
Monterey, California
9. Mr. Edward L. Fisher  
Lecturer of Information Sciences  
Naval Postgraduate School  
Monterey, California
10. Mr. Curtis White  
Commander's Representative  
AFRL/XPW - AFFB/CCT  
USAF Force Protection Battle Lab  
Lackland AFB, Texas



11. Tom Dietz  
Mesh Dynamics  
Santa Clara, California
12. Colonel Thomas Lee Williams  
U.S. Pacific Command (USPACOM)  
Camp Smith, Hawaii
13. Mr. Kurt Badescher  
US Special Operations Command (USSOCOM)  
Tampa, Florida
14. Dr. Leonard Ferrari  
Naval Postgraduate School  
Monterey, California
15. Dr. Frank Shoup  
Naval Postgraduate School  
Monterey, California
16. Mr. Robert Sandoval  
Joint Intelligence Operations Command (JIOC)  
San Antonio, Texas
17. Mr. Craig Shultz  
Lawrence Livermore Laboratories (LLNL)  
Livermore, California
18. Lieutenant General Apichart  
Director-General, Defence Research & Development  
Office (DRDO)  
Parkred, Nonthaburi, Thailand
19. Group Captain Dr. Triroj Virojtriratana  
DRDO COASTS Project Manager  
Parkred, Nonthaburi, Thailand
20. Group Captain Wanchai Tosuwan  
Director, Research & Development Promotion Division  
Parkred, Nonthaburi, Thailand
21. Group Captain Teerachat Krajomkeaw  
Directorate of Operations  
Royal Thailand Air Force (RTAF) Headquarters  
Bangkok, Thailand

22. Capt Josederic  
USAF UAV Battlelab
23. TSgt Kerri D. Gillespie  
USAF UAV Battlelab