



Calhoun: The NPS Institutional Archive

Theses and Dissertations

Thesis Collection

2006-06

Simulation and performance of a high frequency cycloconverter

Gilliom, Jonathan.

Monterey California. Naval Postgraduate School

<http://hdl.handle.net/10945/2773>



Calhoun is a project of the Dudley Knox Library at NPS, furthering the precepts and goals of open government and government transparency. All information contained herein has been approved for release by the NPS Public Affairs Officer.

**Dudley Knox Library / Naval Postgraduate School
411 Dyer Road / 1 University Circle
Monterey, California USA 93943**

<http://www.nps.edu/library>



**NAVAL
POSTGRADUATE
SCHOOL**

MONTEREY, CALIFORNIA

THESIS

**SIMULATION AND PERFORMANCE OF A HIGH
FREQUENCY CYCLOCONVERTER**

by

Jonathan Gilliom

June 2006

Thesis Advisor:

Robert W. Ashton

Second Reader:

Andrew A. Parker

Approved for public release; distribution is unlimited

THIS PAGE INTENTIONALLY LEFT BLANK

REPORT DOCUMENTATION PAGE			<i>Form Approved OMB No. 0704-0188</i>
Public reporting burden for this collection of information is estimated to average 1 hour per response, including the time for reviewing instruction, searching existing data sources, gathering and maintaining the data needed, and completing and reviewing the collection of information. Send comments regarding this burden estimate or any other aspect of this collection of information, including suggestions for reducing this burden, to Washington headquarters Services, Directorate for Information Operations and Reports, 1215 Jefferson Davis Highway, Suite 1204, Arlington, VA 22202-4302, and to the Office of Management and Budget, Paperwork Reduction Project (0704-0188) Washington DC 20503.			
1. AGENCY USE ONLY (Leave blank)	2. REPORT DATE June 2006	3. REPORT TYPE AND DATES COVERED Master's Thesis	
4. TITLE AND SUBTITLE: Simulation and Performance of a High Frequency Cycloconverter			5. FUNDING NUMBERS
6. AUTHOR(S) Jonathan Gilliom			
7. PERFORMING ORGANIZATION NAME(S) AND ADDRESS(ES) Naval Postgraduate School Monterey, CA 93943-5000			8. PERFORMING ORGANIZATION REPORT NUMBER
9. SPONSORING /MONITORING AGENCY NAME(S) AND ADDRESS(ES) N/A			10. SPONSORING/MONITORING AGENCY REPORT NUMBER
11. SUPPLEMENTARY NOTES The views expressed in this thesis are those of the author and do not reflect the official policy or position of the Department of Defense or the U.S. Government.			
12a. DISTRIBUTION / AVAILABILITY STATEMENT Approved for public release; distribution is unlimited			12b. DISTRIBUTION CODE
13. ABSTRACT (maximum 200 words) With modern naval vessels headed in the direction of integrated power systems, new attention must be paid to efficiency of both power and space. However, modern designs for ship power systems often incorporate DC link converters, or synchroconverters, into their design. Not only does this add extra steps into the power conversion process, it also adds the DC link, which requires large capacitors and can aggravate problems experienced in a short circuit. Modern research for cycloconverters is showing that they have many advantages over the synchroconverter when used in a ship power system. However, cycloconverters also have downsides. One of these problems is the incorporation of harmonics into the supply current, distorting the generator output, as well as voltage harmonics at the output of the converter, which can cause problems at the various loads. Most disastrous of all, additions of subharmonics, or interharmonics which occur below the fundamental can appear. Subharmonics are nearly unfilterable and they can cause serious problems for any power system. This study specifically considers higher frequency inputs to see if these subharmonics can be mitigated in a cycloconverter system.			
14. SUBJECT TERMS Integrated Power Systems, Cycloconverter, Synchroconverter, DC link, Subharmonics, Interharmonics			15. NUMBER OF PAGES 119
			16. PRICE CODE
17. SECURITY CLASSIFICATION OF REPORT Unclassified	18. SECURITY CLASSIFICATION OF THIS PAGE Unclassified	19. SECURITY CLASSIFICATION OF ABSTRACT Unclassified	20. LIMITATION OF ABSTRACT UL

THIS PAGE INTENTIONALLY LEFT BLANK

Approved for public release; distribution is unlimited

**SIMULATION AND PERFORMANCE OF A HIGH FREQUENCY
CYCLOCONVERTER**

Jonathan M Gilliom
Ensign, United States Navy
B.S., US Naval Academy, 2005

Submitted in partial fulfillment of the
requirements for the degree of

MASTER OF SCIENCE IN ELECTRICAL ENGINEERING

from the

**NAVAL POSTGRADUATE SCHOOL
June 2006**

Author: Jonathan M. Gilliom

Approved by: Robert W. Ashton
Thesis Advisor

Andrew A. Parker
Second Reader

Jeffrey B. Knorr
Chairman, Department of Electrical Engineering

THIS PAGE INTENTIONALLY LEFT BLANK

ABSTRACT

With modern naval vessels headed in the direction of integrated power systems, new attention must be paid to efficiency of both power and space. However, modern designs for ship power systems often incorporate DC link converters, or synchroconverters, into their design. Not only does this add extra steps into the power conversion process, it also adds the DC link, which requires large capacitors and can aggravate problems experienced in a short circuit. Modern research for cycloconverters is showing that they have many advantages over the synchroconverter when used in a ship power system.

However, cycloconverters also have downsides. One of these problems is the incorporation of harmonics into the supply current, distorting the generator output, as well as voltage harmonics at the output of the converter, which can cause problems at the various loads. Most disastrous of all, additions of subharmonics, or interharmonics which occur below the fundamental can appear. Subharmonics are nearly unfilterable and they can cause serious problems for any power system. This study specifically considers higher frequency inputs to see if these subharmonics can be mitigated in a cycloconverter system.

THIS PAGE INTENTIONALLY LEFT BLANK

TABLE OF CONTENTS

I.	INTRODUCTION.....	1
A.	AC POWER CONVERSION.....	1
1.	Synchroconverters	1
2.	Cycloconverters.....	2
B.	MODERN DAY USAGE OF CYCLOCONVERTERS	4
1.	Cycloconverters in Ship Drive Application	6
2.	Cycloconverters in Other Industrial Applications.....	6
C.	POSSIBLE FUTURE APPLICATIONS OF CYCLOCONVERTERS.....	6
1.	Microturbines and Fast Switching Power Electronics	7
2.	Fast Frequency Cycloconverters	7
D.	APPROACH TO THE STUDY	8
II.	INTRODUCTION TO CYCLOCONVERTERS	9
A.	SINGLE PHASE CYCLOCONVERTER	9
B.	MULTIPLE PHASE CYCLOCONVERTERS.....	11
1.	Basic Cycloconverter Topology	11
2.	Cycloconverter Outputs	13
3.	Cycloconverter Inputs	16
4.	Other Cycloconverter Topologies.....	18
a.	<i>Cycloconverter Pulse Count</i>	19
b.	<i>Induction Elements</i>	19
c.	<i>Isolated Load Phases</i>	20
III.	CYCLOCONVERTER CONTROL STRATEGIES.....	25
A.	CYCLOCONVERTER OPERATING MODES	25
1.	Blocked Mode Cycloconverter.....	25
a.	<i>Discontinuous Current</i>	26
2.	Circulating Current Mode	26
B.	COSINE PULSE FIRING METHOD.....	28
1.	Voltage Controlled Rectifiers.....	28
2.	Cosine Cycloconverter Control	31
C.	OTHER THYRISTOR FIRING METHODS	31
IV.	CYCLOCONVERTER SIMULATION	35
A.	PURPOSE OF SIMULATION	35
B.	DISCUSSION OF SIMULATION	35
1.	Cycloconverter Model	36
2.	Cycloconverter Output Voltage Simulation	36
3.	Cycloconverter Input Current Simulation	37
V.	SIMULATION VERIFICATION	39
A.	MODEL VERIFICATION	39
B.	OUTPUT VERIFICATION.....	39

1.	Output Voltage Signal Verification.....	39
2.	Output Harmonic Verification	41
C.	INPUT HARMONIC VERIFICATION	42
VI.	RESULTS OF SIMULATION.....	45
A.	PERFORMANCE OF OUTPUT VOLTAGE HARMONICS	45
B.	PERFORMANCE OF INPUT CURRENT HARMONICS.....	47
C.	SUMMARY	50
APPENDIX A.	MATLAB CYCLOCONVERTER TEST PROGRAM.....	51
APPENDIX B.	MATLAB OUTPUT TOTAL HARMONIC DISTORTION TEST PROGRAM	65
APPENDIX C.	MATLAB INPUT CURRENT TOTAL HARMONIC DISTORTION TEST PROGRAM.....	81
	LIST OF REFERENCES	99
	INITIAL DISTRIBUTION LIST	101

LIST OF FIGURES

Figure 1.	Block Diagram of a Typical Synchroconverter Circuit and Control [1]	2
Figure 2.	Block Diagram of a Cycloconverter System Feeding a Synchronous Motor [3].....	3
Figure 3.	USCGC Healy Power Plant Schematic [11].....	5
Figure 4.	Single Phase Cycloconverter [13].....	10
Figure 5.	Single Phase Cycloconverter Outputs [13].....	10
Figure 6.	Three-Phase, Six-Pulse Cycloconverter Feeding a Three-Phase Machine [10].....	12
Figure 7.	Outputs of a Single Phase of a Six-Pulse, Three-Phase Circulating Current Cycloconverter [10]	14
Figure 8.	Harmonics Present in Output Voltage of a Cycloconverter [10].....	15
Figure 9.	Pictorial of sequence dominants bands of a bridge cycloconverter operating at 18 Hz from 60 Hz supply. [7]	17
Figure 10.	Input Current Harmonics on an Ideal 12-Pulse Cycloconverter [15]	18
Figure 11.	Six-Pulse Cycloconverter with Isolated Loads [10]	21
Figure 12.	Twelve-Pulse Bridge Cycloconverter [10]	22
Figure 13.	Three-Pulse, Midpoint Cycloconverter [10].....	23
Figure 14.	Example Output Voltage of a Blocked Mode Cycloconverter [3]	26
Figure 15.	Circulating Current Through a Cycloconverter [10]	27
Figure 16.	Three-Phase Rectifier and Corresponding Diode Firing Patterns [16].....	28
Figure 17.	Timing Waveform Example	29
Figure 18.	Example of Rectifier Control with DC Reference Voltage [10].....	30
Figure 19.	Input Waveforms into Cycloconverter.....	32
Figure 20.	Timing Waveforms and Algorithm Input	32
Figure 21.	Timing Waveforms with a Zero Voltage Trigger.....	33
Figure 22.	Normalized Output of the Positive Converter	40
Figure 23.	Normalized Output of the Negative Converter.....	40
Figure 24.	Normalized Output of the Cycloconverter.....	41
Figure 25.	Frequency Spectrum of Cycloconverter With Input Frequency 100 Hz, Output Frequency 14 Hz.....	42
Figure 26.	Positive Converter Harmonic Current	43
Figure 27.	Negative Converter Harmonic Current.....	43
Figure 28.	Output Total Harmonic Distortion of a Cycloconverter	46
Figure 29.	Output Current Total Harmonic Distortion of a Cycloconverter.....	46
Figure 30.	Positive Converter Input Current Total Harmonic Distortion	48
Figure 31.	Negative Converter Input Current Total Harmonic Distortion.....	48
Figure 32.	Combined Converters Input Current Total Harmonic Distortion.....	49

THIS PAGE INTENTIONALLY LEFT BLANK

LIST OF TABLES

Table 1. Frequency Components of AC Signals [7]4

THIS PAGE INTENTIONALLY LEFT BLANK

ACKNOWLEDGMENTS

I would like to thank Professor Ashton for his direction in this study, as well as the inhabitants of Sp-307 for never failing to distract me when I was doing any real work.

THIS PAGE INTENTIONALLY LEFT BLANK

EXECUTIVE SUMMARY

This purpose of this thesis is to broaden the spectrum of a modern power system for use in integrated power systems in naval vessels. The cycloconverter has long been capable of supplying large amounts of power at low frequencies, but its use has been limited to low input frequencies because of the power devices used. Now that solid state power switching capability is quickly becoming able to switch at much higher speeds, and new switches are being developed to switch lower power at much higher speeds, the cycloconverter could become a much more versatile system. Specifically, a higher input frequency into the cycloconverter could eliminate the low frequency limitation at the output.

Using a computer model, this thesis undertakes the question of how higher input frequency would affect the input and output power distortions occurring in a cycloconverter. The model was developed in Matlab™ and consisted entirely of sets of arrays that held the information of various voltage waveforms. These arrays were cut into distinct sections depending on which switches in the cycloconverter were currently on to form the output waveforms, which were then cut into pieces themselves to form the input effects on the cycloconverter. All code used in this thesis is attached.

Simulation of a high frequency cycloconverter revealed that an increased frequency input does decrease the distortions in the output current. Distortions currents in the output load decreased exponentially as the input frequency was raised. However, increasing the input frequency had little effect on the magnitude of input current distortions. Regardless of how high the input frequency, current distortions did not follow any progressive downward trend. The magnitudes of output voltage distortions were similarly unaffected by increasing the input frequency.

These results are mixed for the use of a high frequency cycloconverter in a ship drive. As cycloconverters already have many advantages over other power converters low speed, high power applications, decreasing the output current distortions does help to increase the efficiency of the load. Though the input distortions are fairly high for the

cycloconverter and do not fluctuate over the frequency of the input, the same is true for the equivalent rectifier circuit. The only way to decrease the distortions on the input is to increase the complexity of the conversion system. However, the ability of cycloconverters to produce a purer output current as the input frequency is increased is unique to the cycloconverter. A rectifier-inverter circuit cannot reproduce the same effect. This does seem to give the high frequency cycloconverter a slight edge for the possibility of ship drive application, an area where cycloconverters already perform well.

I. INTRODUCTION

This chapter is an introduction to modern multi-megawatt AC-AC power conversion, how it is accomplished, and what devices are used. Cycloconverters are briefly discussed as a common method AC power conversion and as the focus of this study. Modern day uses of the cycloconverter are stated, as well as potential uses in the future.

A. AC POWER CONVERSION

Power generators, regardless of whether small or large scale, almost always produce an AC output. However the actual parameters of the power often vary. Standards are often different in different countries, and to make matters worse, load applications often ignore these supply power standards entirely when they are designed. Therefore, it becomes absolutely necessary for AC power conversion: the ability to change power from one voltage and frequency to another voltage and frequency without incurring high losses of power in the process.

1. Synchroconverters

The vast majority of AC-AC power converters on the market today do not actually convert power directly from AC power of one frequency to AC power of another frequency. Instead, these converters first convert electrical power to DC using a rectifier, and then convert power back into AC using an inverter as in Figure 1. This topology has several advantages, not the least of which is that both rectifier and inverter topologies have been studied thoroughly and the techniques used in their implementation are very well known. Control strategies have also been well developed for increasing the accuracy of producing an output waveform, including Pulse Width Modulation (PWM) of the signal so that output voltage harmonics can be directly controlled. Also, there are no limitations imposed on the input or output frequencies providing semiconductor switching device limits are not reached. However, there are also downsides to this topology [1].

The most evident downfall of the synchroconverter is degraded efficiency due to the two distinct power conversion systems, rectifier and inverter. Power losses occur in each semiconductor element of the system both during switching events and as a voltage

drop while the devices are on. Losses also occur as a blocking loss due to leakage current when the device is off, although these losses are negligible in comparison with the other two sources. Other significant loss contributors include passives such as transformers for galvanic isolation and level shifting, inductors and capacitors for filtering. More conversion steps results in more semiconductors and passives through which power must travel, which adds power loss. Additionally, the connection between the rectifier and the inverter elements creates a DC bus line, or a DC link, which is prone to shorting and other failures. In high power applications, this problem is exacerbated by having large capacitors on the DC link to keep a consistent voltage which, in the event of a short, channel large amounts of additional energy into the fault, creating additional hazard [2]. Figure 1 shows a model synchroconverter, illustrating the DC bus between the rectifier and inverter.

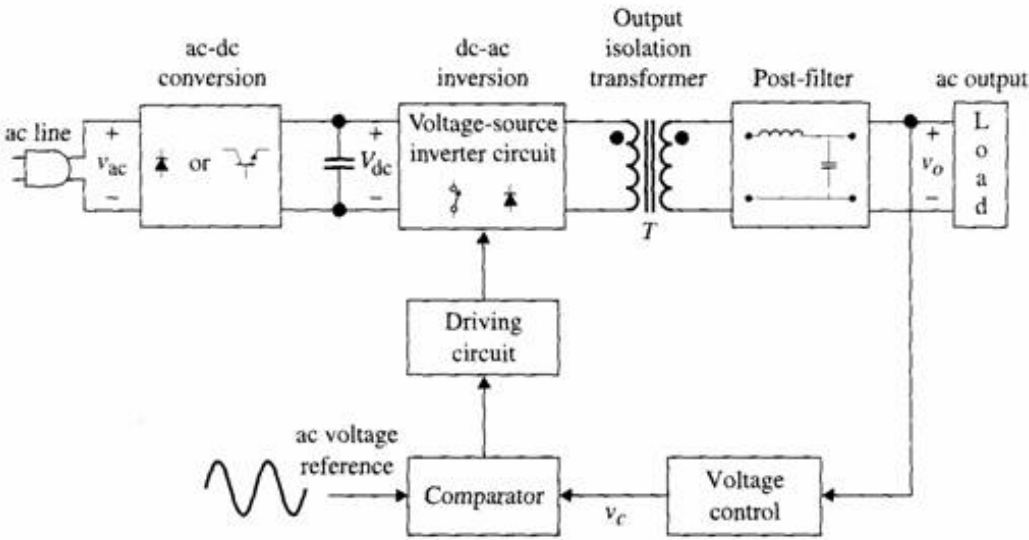

Figure 1. Block Diagram of a Typical Synchroconverter Circuit and Control [1]

2. Cycloconverters

Cycloconverters are a single-stage solution that addresses the shortcomings of synchroconverters. Cycloconverters not only eliminate the problem of having multiple systems to perform a single function, they also limit the flow of power to a single switch at any one period in time. Therefore, there is no bus link, DC or otherwise, included in a cycloconverter topology between power input and power output. Figure 2 shows a

typical cycloconverter circuit block diagram. The system is fed by transformers and contains no bus link between the input of the cycloconverter and the output to the load.

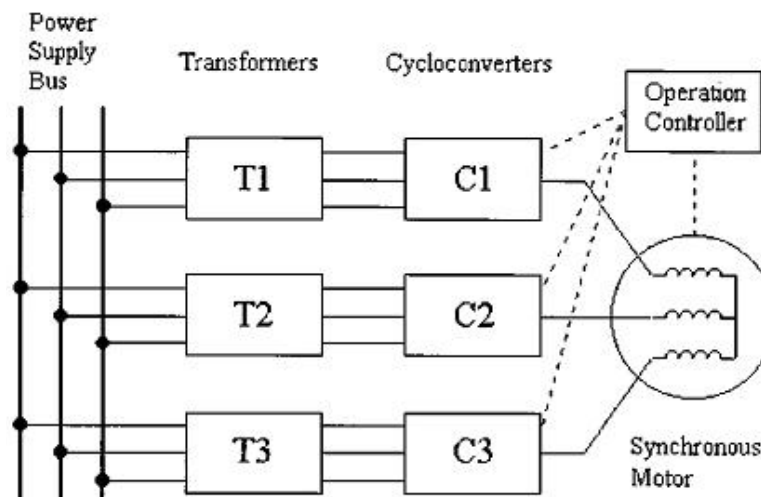

Figure 2. Block Diagram of a Cycloconverter System Feeding a Synchronous Motor [3]

Cycloconverters however, have a rash of other problems. Because cycloconverters directly manipulate input signals at alternating intervals, they do not produce output harmonics in the way that an inverter circuit does. The frequencies of the harmonics produced in the inverter are usually multiples of, and are entirely dependent on the inverter switching speed. Instead, cycloconverters produce interharmonics, which are side lobe frequencies based on both the input and output of the system. The presence of these interharmonic frequencies can be especially problematic because they are not necessarily greater than the output frequency [4-6].

Harmonics below the output frequency can be extremely detrimental to load performance. Because these frequencies occur close to the desired output, they are difficult to filter without drastically altering the fundamental, the sinusoidal waveform at the desired output frequency. Dubbed subharmonics, these undesired frequencies constitute one of the most important reasons why cycloconverters are impractical in many applications. Table 1 shows frequency components of output wave signals. Inverters often produce harmonics, where cycloconverters produce interharmonics, and at times, subharmonics.

Table 1. Frequency Components of AC Signals [7]

harmonic	$f = hf_s$	where h is an integer >0
DC	$f = 0$	$f = hf_s$ where $h = 0$
interharmonic	$f \neq hf_s$	where h is an integer >0
subharmonic	$f > 0$ and $f < f_s$	

where f_s = fundamental or wanted frequency component.

The occurrence of these harmonics is most noticeable at high output-to-input frequency ratios. Therefore, the easiest solution to limiting these unwanted frequencies is to limit the output-to-input frequency ratio of the cycloconverter. This limit changes with the topology of the cycloconverter, although ratio limits of 0.5 or less are not uncommon on the simplest cycloconverter topologies. As the complexity of the cycloconverter increases, however, this bound on usable output frequencies approaches one [6].

The use of cycloconverters also creates adverse affects on the input of the cycloconverter system. Harmonics are produced in the input current, and the input power factor can be low depending on the load. These affects are consistent with rectifiers, though harmonics occur at different intervals in cycloconverters than occur in rectifiers [8].

B. MODERN DAY USAGE OF CYCLOCONVERTERS

As stated above synchroconverters often waste power through multiple switching stages and include dangerous high voltage DC lines. Cycloconverters avoid these problems and consequently are often used in the realm of low speed, high horsepower application. Additionally, cycloconverters can independently control both output frequency and voltage and have the ability for four quadrant operation, which allows reverse and regeneration. Reverse operation being the situation where currents are run the opposite direction to convention, which can be accomplished in three-phase systems by switching two of the inputs or in cycloconverters by simply changing the controls. This causes the motor to spin in the reverse direction as well. Regeneration is the condition where stored currents in the load are allowed to flow back into the source

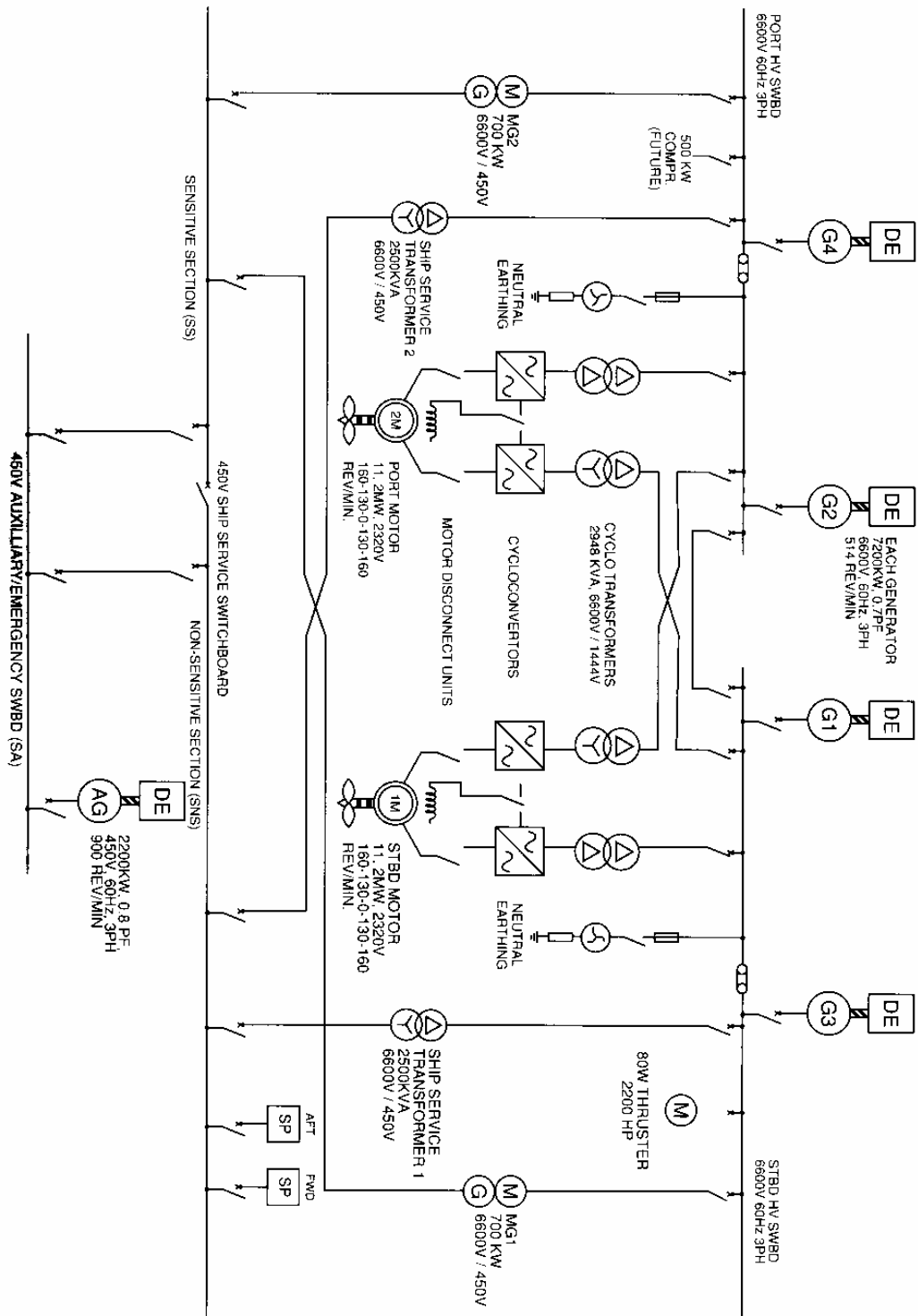

Figure 3. USCGC Healy Power Plant Schematic [11].

after input power has been disconnected. This both slows the motor load (braking) and allows the generator to recoup some of the energy lost in passive energy storage elements [9,10].

1. Cycloconverters in Ship Drive Application

These conditions are precisely what are required in electric ship drives, and cycloconverter systems are being considered as one of the preferred options for power conversion in the newest fully electric propulsion warships. The shaft of a ship is needed to spin at a relatively low speed with a high torque. Direct speed control, as well as direct power control is essential for maintaining the speed of the ship during different operating environments, and four quadrant (allowing reverse and regeneration) operations is essential for moving in reverse as well as being energy efficient. This is especially true in the case of icebreaking ships. These ships require immense amounts of power while still moving at low speeds because of the challenges in breaking up ice [4].

The USCGC Healy, an icebreaker commissioned in November 1999, includes in its integrated power plant a cycloconverter dedicated to each of the motors. Though the four diesel generators supply power at 60 Hz, the shaft often needs to function at very low speeds to maximize torque. Cycloconverters were added to allow this functionality. Using the frequency controls on the cycloconverter allows the Healy to vary the frequency at which the motors are operating, and therefore to change the speed that the propeller spins. For AC machines, electrical frequency is directly proportional to the no-load mechanical frequency of the propeller, though induction machines mechanical speed lowers as load is applied [11].

2. Cycloconverters in Other Industrial Applications

Cycloconverters are also used in other high power industrial applications. Gearless cement mills, steel rolling mills, ore grinding mills, pumps and compressors, and mine winders are all current applications of the cycloconverter because of its benefits with high power, low speed devices [9].

C. POSSIBLE FUTURE APPLICATIONS OF CYCLOCONVERTERS

Many of the problems with employing cycloconverters in real power applications result directly because of the problems with subharmonics. If generators for the

cycloconverter or the cycloconverter loads are not robust enough to deal with imperfect power quality, the cycloconverter is forced into very strict operating conditions. Output frequency must be limited in order to contain harmonics within a filterable spectrum. However, these limitations are all based on the assumption that the input power for the cycloconverter is coming from a standard generator. Current technology has been able to expand the possible usage of cycloconverters away from these limiting assumptions.

1. Microturbines and Fast Switching Power Electronics

The recent increase in distributed power generation has led a flurry of research on microturbines. Microturbines are an integration of gas combustion engines and electric generators, which produces an output power on the order of hundreds of kilowatts at tens of kilohertz. This is an extreme jump from diesel generators, which often produce power at 60 Hz. However solid state switching limitations are quickly lifting with the incorporation of new device technologies and microturbine research continues to produce varied models. It is very possible that there will soon be a possible combination of higher frequency generators and cycloconverters [12].

The other technology that has restricted the development of the cycloconverter to slow operating machinery is the limited switching speeds of most present day power electronic switches. However, with better switching technology such as higher speed thyristors or new high power integrated gate bipolar transistors, cycloconverters could be used with these high frequency generators. This would effectively eliminate output-to-input ratio issues including the unfilterable subharmonics and interharmonics contained in both outputs and inputs [3].

2. Fast Frequency Cycloconverters

As stated before, the most glaring fault of the cycloconverter is bounded output-to-input frequency ratio. In addition, many cycloconverters have a restricted input frequency of 60 Hz due to semiconductor switch limitations. However, if the input limitations were changed so that the input frequency was several times higher than the output, the cycloconverter would certainly operate with improved efficiency and reduced harmonics. However, this condition has not been thoroughly studied.

D. APPROACH TO THE STUDY

This thesis endeavors to uncover the theoretical benefits of a high frequency cycloconverter. Though it is assumed that the influence of harmonics on both the input and output will diminish as input frequency with respect to output frequency increases, this thesis endeavors to document the changes in the harmonics, and determine whether high frequency cycloconverters are feasible alternatives for navy propulsion drives.

Chapter II is an in depth view of how cycloconverters are designed. Both single and three-phase cycloconverter topologies are discussed in addition to input and output harmonics. Chapter III includes the use of cycloconverter control strategies and how they are implemented. Chapter IV explains how the actual research was conducted. The design strategy for the model cycloconverter is discussed and how this model reflects the reality of cycloconverter behavior. Chapter V contains the results from the simulation and conclusions can be drawn from these results. The conclusions sum up the practicality of a high frequency cycloconverter.

II. INTRODUCTION TO CYCLOCONVERTERS

As stated in the previous chapter, cycloconverters are AC-AC power converters that change power from one frequency and voltage on the input, to another frequency and voltage on the output. This is accomplished through the use of multiple switching events during the output period which connect various input to outputs. Thus, output waveforms are created from discrete sections of input source waveforms. Cycloconverters can be used in single and multi-phase applications, although single-phase input cycloconverters that do not include resonant components produce very crude outputs.

A. SINGLE PHASE CYCLOCONVERTER

The simplest way to understand the principles behind a three phase cycloconverter is by first evaluating the operation of a single phase cycloconverter. The theory of the operation of the two devices is similar. Regardless of phase count the cycloconverter breaks each incoming waveform into discrete pieces and directs of those pieces to the output to construct the desired waveform.

A single phase cycloconverter is in essence two bridge rectifiers in reverse parallel. One of the rectifiers will always conduct a positive current and voltage, while the other rectifier will always conduct a negative current and voltage. This topology is shown in Figure 4. Pieces of the positive rectifier output can then be intertwined with pieces from the negative rectifier output. For example, four half cycles may be taken from the output of the positive converter, followed by four half cycles of the output of the negative converter. This condition is shown in Figure 5, and produces a waveform that is then at one fourth of the frequency of the original input wave. This can be done for any number of half cycles, even non-integer values. If an output frequency of 1 Hz is desired, then the positive converter is turned on for 0.5 seconds and then the negative converter is turned on for 0.5 seconds, regardless of the input frequency. However, it should also be noted, that there will always be harmonic components of the output that are at a frequency no less that twice the input, due to the process of rectification. Therefore, it is always desirable for the output frequency to be lower than the input frequency, so that harmonics can be successfully filtered [13].

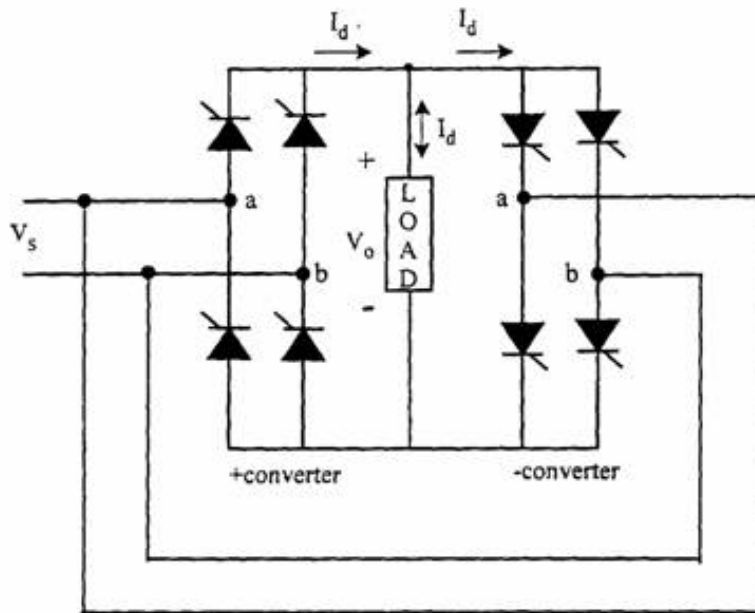

Figure 4. Single Phase Cycloconverter [13]

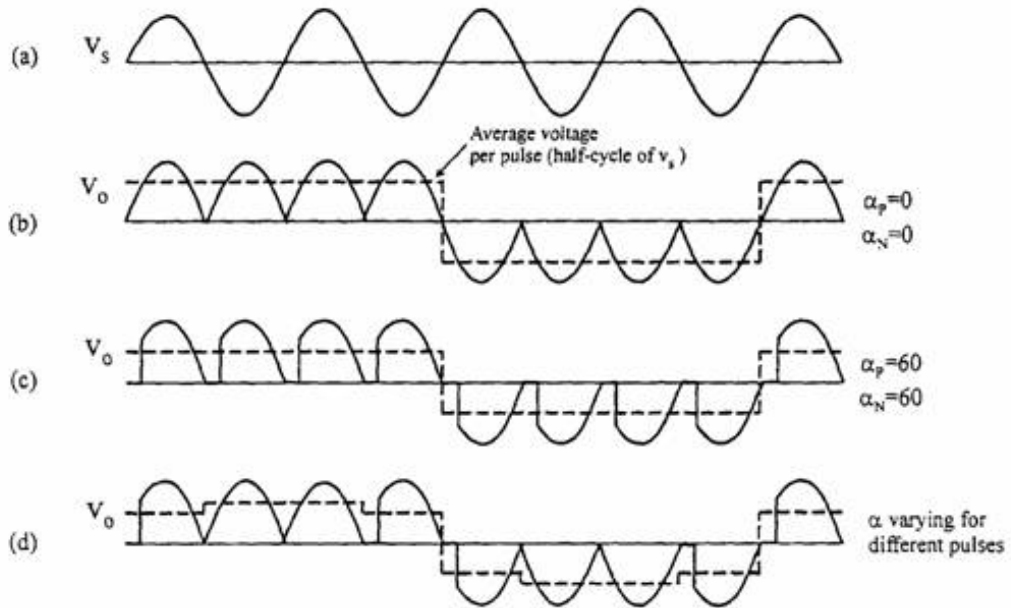

Figure 5. Single Phase Cycloconverter Outputs [13]

- a) Input voltage
- b) Output voltage for zero firing angle
- c) Output voltage for firing angle of 60 degrees
- d) Output voltage with varying firing angle

Similar to a rectifier, cycloconverters also use, and are in fact dependent on, phase control. By using thyristors, a rectifier can be set to turn ‘on’ when the input reaches a certain voltage so that the output is voltage controlled. Similarly, the cycloconverter uses thyristors to control the voltage at the output, although these controls are dynamic over the period of the output waveform. Figure 5-d shows the firing angle of the thyristors changing over the cycle of the output. This dynamic process produces an output waveform that more closely resembles a sinusoid than the non-dynamic process in Figure 5-b [13]. However, even in this last improved waveform the output is far from sinusoidal. The single-phase cycloconverter shown above lacks a variety of inputs to draw power from and therefore cannot produce a clean output. Adding multiple phases on the input of the cycloconverter drastically improves the performance of the system.

B. MULTIPLE PHASE CYCLOCONVERTERS

Though the single-phase cycloconverter shows how a cycloconverter works in theory, its performance is generally abysmal. There are simply not enough inputs to draw power from in order to construct a ‘clean’ sinusoidal output. Multi-phase cycloconverters are much more effective in producing clean waveforms due to the variety of input to choose from.

1. Basic Cycloconverter Topology

Though there are many cycloconverter topologies to take advantage of various load structures and desired outputs, the standard cycloconverter is shown in Figure 6. This is a full bridge cycloconverter with a three-phase input, and both a positive and a negative converter for each of the outputs. This topology is very similar to the single-phase cycloconverter in Figure 4 with a few exceptions. Primarily, there are three separate converters to provide the three-phase output. Also, the additional line on the input to each of the converters provides the three times as many sources for different voltage levels, allowing a much more accurately constructed sinusoidal output than that of the single-phase unit. Lastly, inductive elements separate each of the positive and negative converters, which allow both of the converters to be on at the same time. This is a very common technique used in cycloconverters and will be discussed more in depth later on in the chapter.

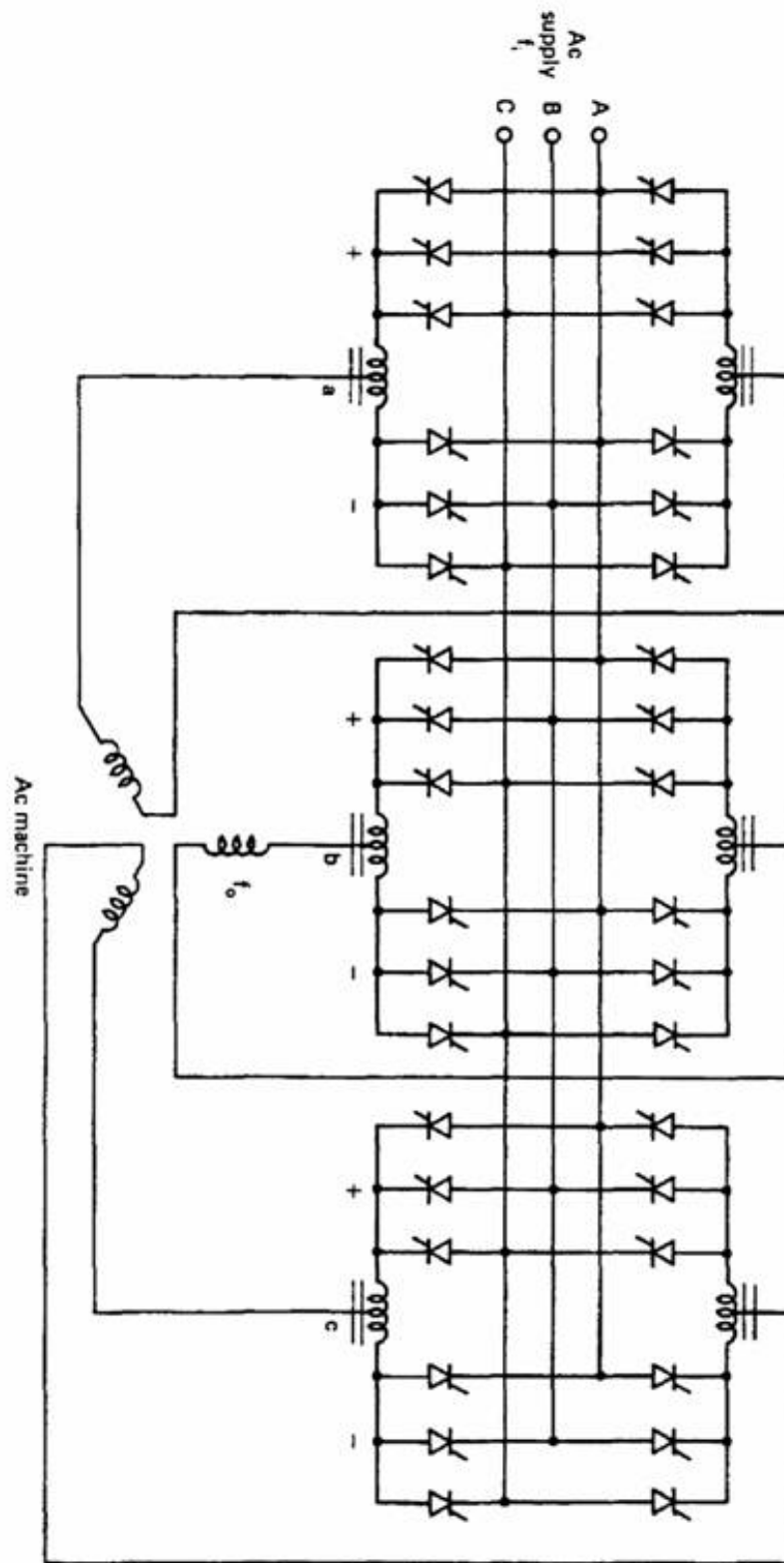

Figure 6. Three-Phase, Six-Pulse Cycloconverter Feeding a Three-Phase Machine [10]

2. Cycloconverter Outputs

Because each of the three-phase outputs of the cycloconverter is simply the same waveform shifted by 120 degrees, each of the output waveforms has the same properties. Therefore, studying only one of the output phases at a time will give sufficient information to all three outputs in general. For simplicity, all figures in this section are of a single output phase.

Figure 7 shows the voltage outputs of the cycloconverter shown in Figure 5. The background waves in each of the three different traces are the six different phase voltages that are possible across the output load of the Cycloconverter: phases AB, BC, and CA and their opposites. The hashed line is a reference waveform at the desired frequency of the output. The top trace shows the output of the positive converter. Notice that the positive converter always switches to a higher voltage, showing that the positive converter is always conducting positive current to the load. This is the reason it is called the positive converter. Conversely, the negative converter always switches to a more negative voltage, showing that it is conducting negative current. The output of the center tap on the inductive element is the final trace. The summing inductor effectively averages the positive and negative waveforms resulting in a composite waveform that is substantially more sinusoidal than either of the components. It is important to note that the output voltage waveform is at a frequency of about one-half or two-fifths of the input frequency, a standard ratio for cycloconverter operation. At these ratios, the cycloconverter forms defined steps. The behavior of a cycloconverter at a smaller ratio provides slightly different results [10].

The cusps and corners in the output waveform are the source of the large quantity of the harmonics in the waveform. Similar step and PWM inverters with a switching frequency based on an integer value of the output fundamental produce harmonics at frequencies defined by [14]

$$f_h = (2n+1)f_o \quad (2.1)$$

where $n = 1,2,3...$ f_h is the frequency of the output harmonic and f_o is the fundamental output frequency.

The six-pulse cycloconverter produces harmonics defined by [10]

$$f_h = 6pf_i \pm (2n+1)f_o \quad (2.2)$$

where $n = 0,1,2,3\dots$ and $p = 1,2,3\dots$ and f_i is the input source frequency.

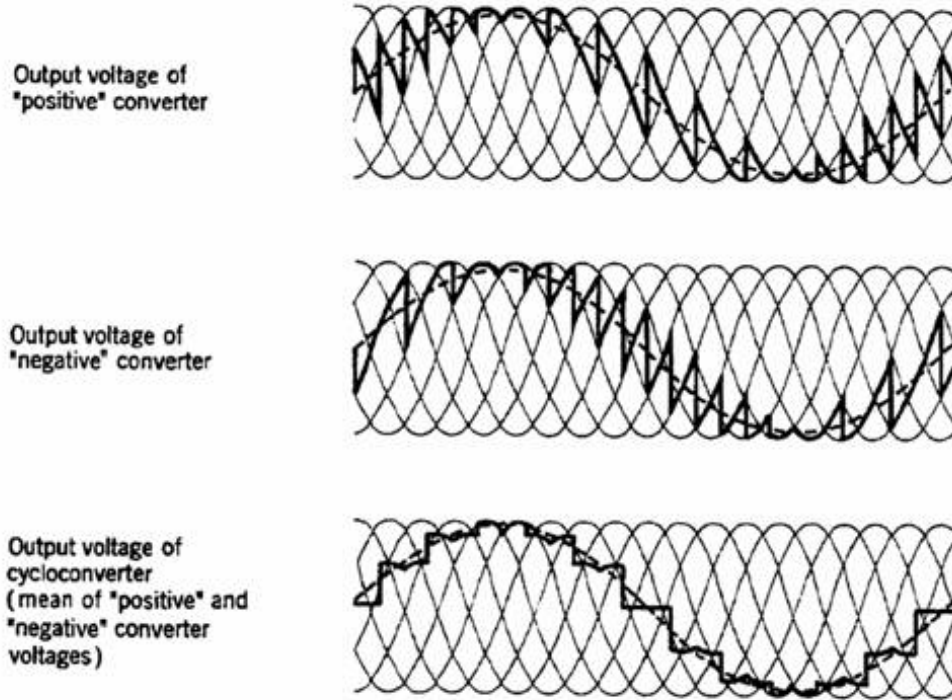

Figure 7. Outputs of a Single Phase of a Six-Pulse, Three-Phase Circulating Current Cycloconverter [10]

Taking (2.2) literally, the lowest order harmonic would be very low frequency term as when p is set to 1, n can be set to any number such that the output harmonics are barely greater than zero. However, as n gets larger, the magnitudes of the harmonic frequencies decrease; harmonics corresponding to high n values often are insignificant. In practice this creates a window for n depending on p . For example, in a six pulse cycloconverter where the input is 60 Hz and the output is 24 Hz the lowest frequency harmonic with a substantial magnitude occurs at 192 Hz where $p = 1$ and $n = 3$. Values of n greater than 3 do not produce substantial harmonics in this case. The reason that cycloconverters have these harmonic windows rather than single harmonic terms is the constantly changing firing angle on the thyristors. However, not all of the harmonics in this window really appear on the output of the cycloconverter. Harmonics in the positive and negative converter often combine and cancel one another entirely.

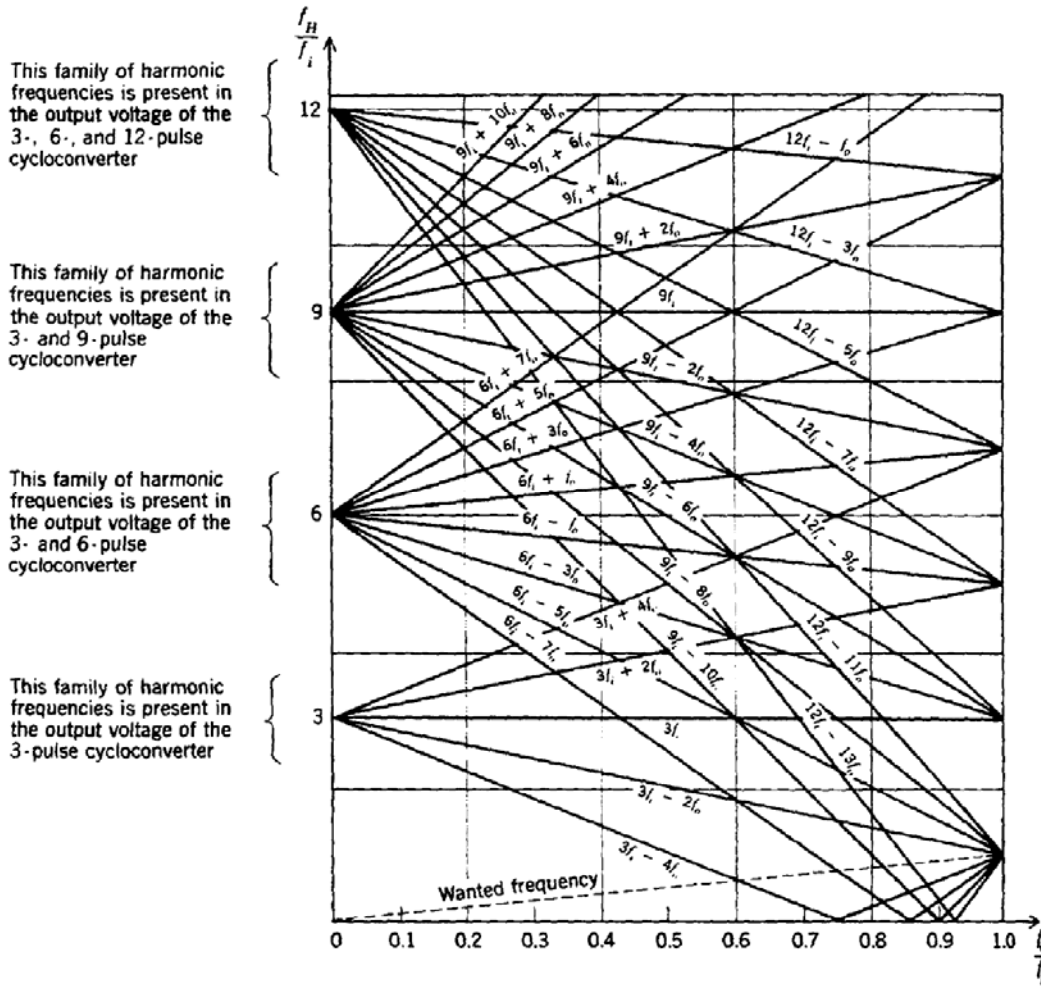

Figure 8. Harmonics Present in Output Voltage of a Cycloconverter [10]

Figure 8 shows the effects of these windows for three, six, nine, and twelve pulse cycloconverters. As the quantity of Ppf_i in (2.2) increases, the window for n grows larger. This can be seen in Figure 8. As the frequency increases on the y axis, the clusters of harmonic frequencies grow to include more harmonics. The lowest frequency set of output harmonics for a three-pulse cycloconverter has only five strong harmonics associated with it, corresponding to only n values of 0, 1, and 2. The lowest frequency set of harmonics on a twelve-pulse cycloconverter has fourteen corresponding to n values of 0-6. The fact that the bands of these frequency windows expand or contract as the output-to-input frequency ratio changes can be both an advantage and a disadvantage to the cycloconverter. In low output-to-input frequency ranges, the

frequencies of the harmonics are large compared to the output frequency, and are therefore easily filterable. As the output-to-input frequency ratio increases though, the frequency of the lowest frequency harmonic decreases, making it progressively more difficult to filter. This becomes a pronounced problem when the harmonic frequencies approach the output frequency because these harmonics cannot be filtered from the load current [10].

It is important to note that these are not the only harmonics that occur at the output of the cycloconverter. Several factors, including imperfect timing on switching, and switching control method can induce distortion at different frequencies than those shown above. This occurs similarly in the case of a typical PWM inverter. Cycloconverters also have distortion at the frequencies described in (2.1) that are outside of accepted windows. However these distortions are often insignificant in comparison to the harmonics that occur naturally [10].

Figure 9 shows how smaller voltage harmonics appear outside of the windows defined by Equation (2.2). These ‘daughter’ harmonics occur when the small sidebands of two or more of the frequency windows combine – at times causing a doubling of the voltage harmonic or more depending on how the sidebands combine. This can also be seen where two major harmonics occur at the same frequency. As the value of Ppf_i increases to larger values, or as the output-to-input frequency ratio of the cycloconverter increases, even major harmonics can overlap, which is demonstrated in Figure 8 where the lines representing different harmonics cross [7].

3. Cycloconverter Inputs

Controlling the input voltage waveforms to make the desired output also creates harmonics in the source of the cycloconverter. Currents from each of the input phases can only flow when the corresponding thyristors are closed. This creates pulsations in the input current, which corresponds to harmonic current distortion that can be detrimental to the generator source. Input current harmonics on each phase of an optimally switched six-pulse cycloconverter can be defined by these relations [15]

$$f_{hi1} = |f_i \pm 2mf_o| \quad (2.3)$$

$$f_{hi2} = |(6p \pm 1)f_i \pm 2mf_o| \quad (2.4)$$

where $p = 1, 2, 3, \dots$ and $m = 0, 1, 2, \dots$

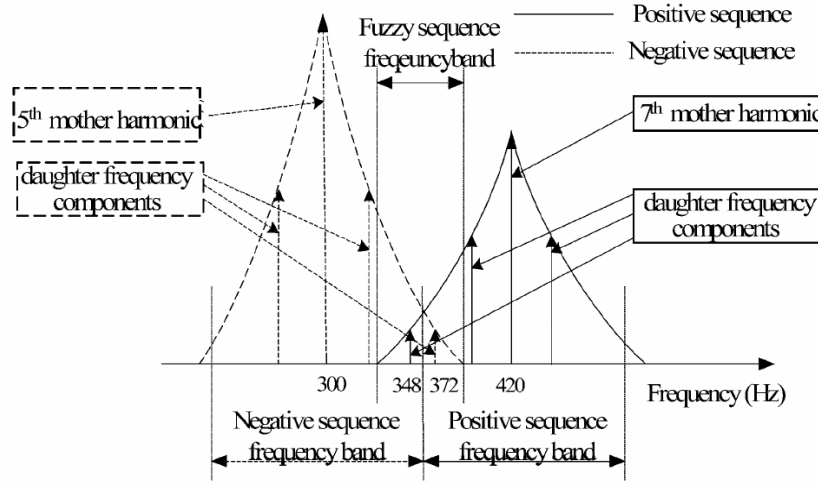

Figure 9. Pictorial of sequence dominants bands of a bridge cycloconverter operating at 18 Hz from 60 Hz supply. [7]

As with the output, many of these harmonics cancel each other when the cycloconverter is in ideal use because of complementary harmonics created from the input of each due to each of the outputs. The harmonics for a six pulse converter after these cancellations become [15]

$$f_{6-pulse} = |(6p \pm 1)f_i \pm 6kf_o| \quad (2.5)$$

where only the case where $m = 3k$ need be considered due to cancellation. Figure 10 shows input current harmonics for a 12-pulse cycloconverter, which is very similar to the 6-pulse except for the addition of harmonics around $5f_i$ and $7f_i$.

These harmonics are not at all desirable, as they force a generator designed to output current at f_i to also source currents at much higher frequencies, currents which cannot be applied to useful work. Therefore, lowering input distortion current is desirable for higher efficiency of the system. Since harmonic currents cause additional non-productive heating of the generator, lower input distortion leads to a cooler generator, enhancing reliability. Lower distortion can be accomplished by increasing

the pulse count of the cycloconverter system. It is also imperative that the system loads remain balanced. Otherwise, various harmonics included in (2.4) that were cancelled due to the three-phase nature of the system, remain, and further degrade system performance. Lastly, keeping the output of the cycloconverter at maximum voltage prevents wasting large percentages of power, similar to the use of a voltage controlled rectifier [15].

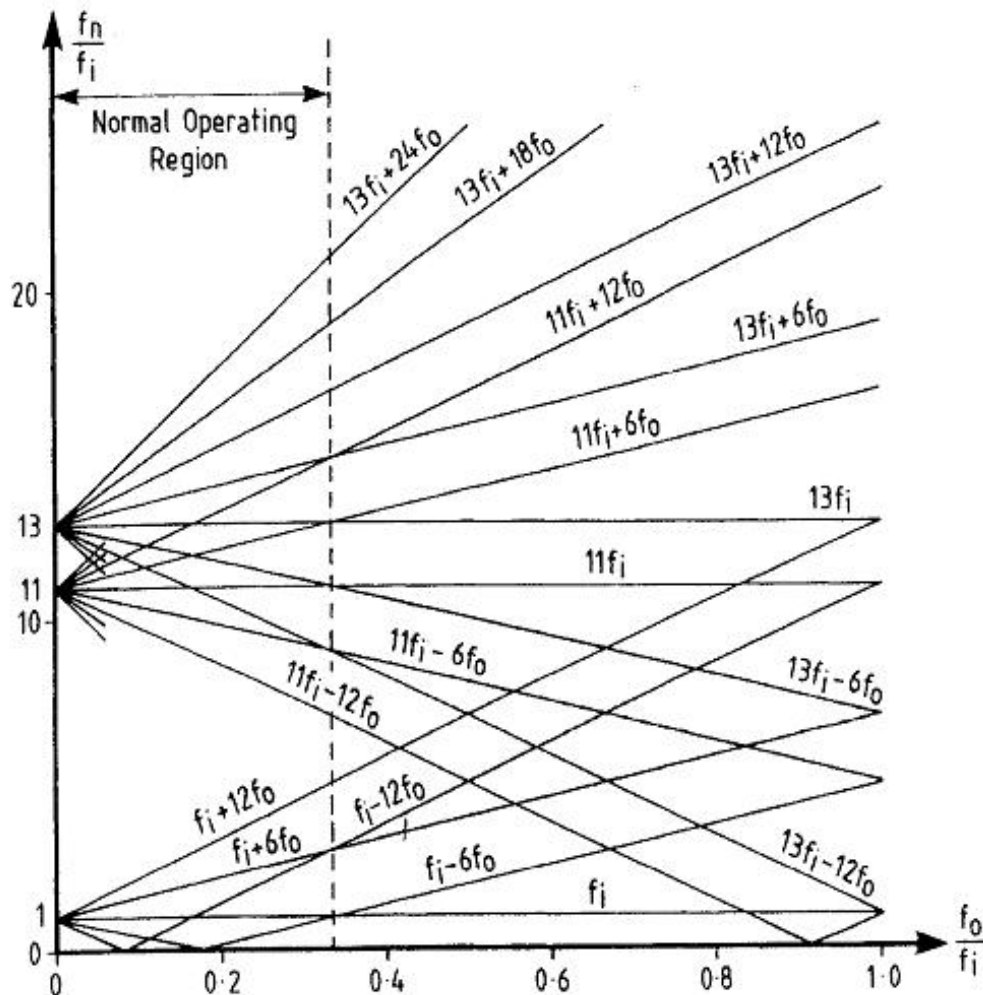

Figure 10. Input Current Harmonics on an Ideal 12-Pulse Cycloconverter [15]

4. Other Cycloconverter Topologies

The Cycloconverter shown in Figure 6 is only one of a bevy of different cycloconverter topologies. The cycloconverter changes its topology not only as a function of how many phases are required on the input or the output of a system, but

also due to several other important factors. One of the major tradeoffs in cycloconverter design is the increasing complexity of the system as power efficiency and quality of the converter increase. Another tradeoff is the inclusion of bulky inductors which filter harmonics, but also degrade power factor and waste energy. These tradeoffs lead to three different specific changes in topology. Figures 11, 12 and 13 show various changes to cycloconverter structure that demonstrate these changes.

a. Cycloconverter Pulse Count

Pulse count is the single most important factor in how well the cycloconverter performs. Figure 9 shows that as the pulse count of the cycloconverter increases, lower order harmonics are eliminated. However, this occurs both on the output voltage and on the input current, eliminating the hardest to filter distortions. Unfortunately, this benefit comes at the expense not only of circuit complexity, but also the complexity of the controls. The pulse count refers to how many discrete segments of the input wave occur in each cycle of the thyristor controls. The six-pulse converter has six different thyristors for each of the positive and negative converters. These thyristors fire in a designated and repeated sequence (though not for the same length of time) for each input period – therefore it is designated as six-pulse. Doubling the pulse count of a circuit topology also generally doubles the number of thyristors needed in a cycloconverter, which also doubles the needed control inputs. However, this has the added bonus of allowing more power through the cycloconverter. The larger the amount of thyristors in the cycloconverter circuit, the greater the amount of power that the cycloconverter is capable of channeling [10].

b. Induction Elements

The Cycloconverter in Figure 6 shows inductive elements between both ends of the positive and negative converters, which are called inter-group reactors. These reactors serve the single purpose of allowing current to flow in both converters at the same time. It is possible to have a cycloconverter that does not have inter-group reactors, which in addition to preventing both converters to be on at the same time, changes many other aspects of the cycloconverter. Firstly, since the converter supplying power to the load (the positive converter supplies positive current to the load, the negative converter supplies negative current) no longer has to supply additional current

to the other converter, thyristors with a lower power rating can be used. Secondly, power that was lost in the inductors due to the reduction of power factor and the conduction losses of the converters not in use are eliminated, increasing the performance. However, harmonics which had been cancelled due to the simultaneous operation of the two converters will now become a problem both on the input and the output of the system, decreasing the performance of the machine. These performance losses most often outweigh the efficiency gained by removing the inductive elements. Lastly the removal of the inter-group reactors makes it imperative that the converters are not on simultaneously, so control strategy must be augmented to ensure the safety of the system. It is not generally desired to remove the inter-group reactors from a cycloconverter circuit [10].

c. Isolated Load Phases

Cycloconverters do not always have to supply power to different phases of an AC machine. They can just as easily be used for entirely independent loads. However, it is important to note that these phase loads must still be well balanced or else unnecessary harmonics will be induced at the input current [10].

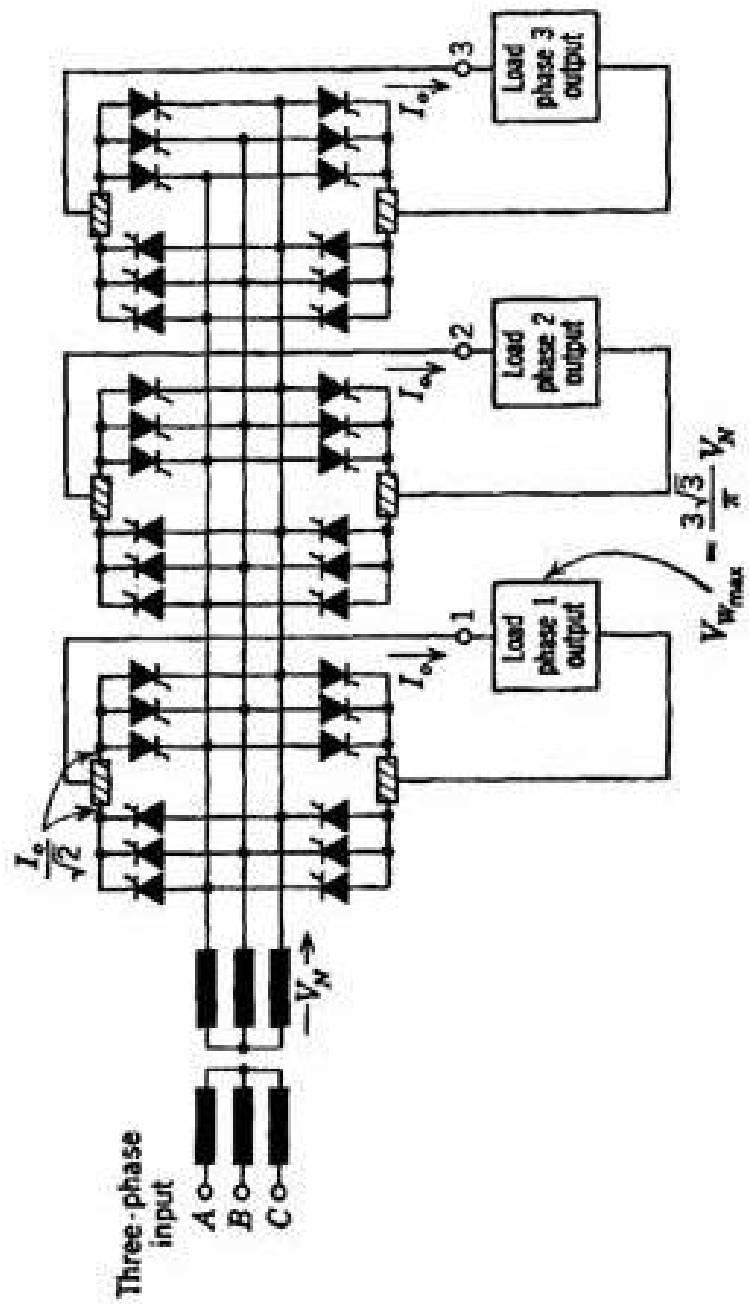

Figure 11. Six-Pulse Cycloconverter with Isolated Loads [10]

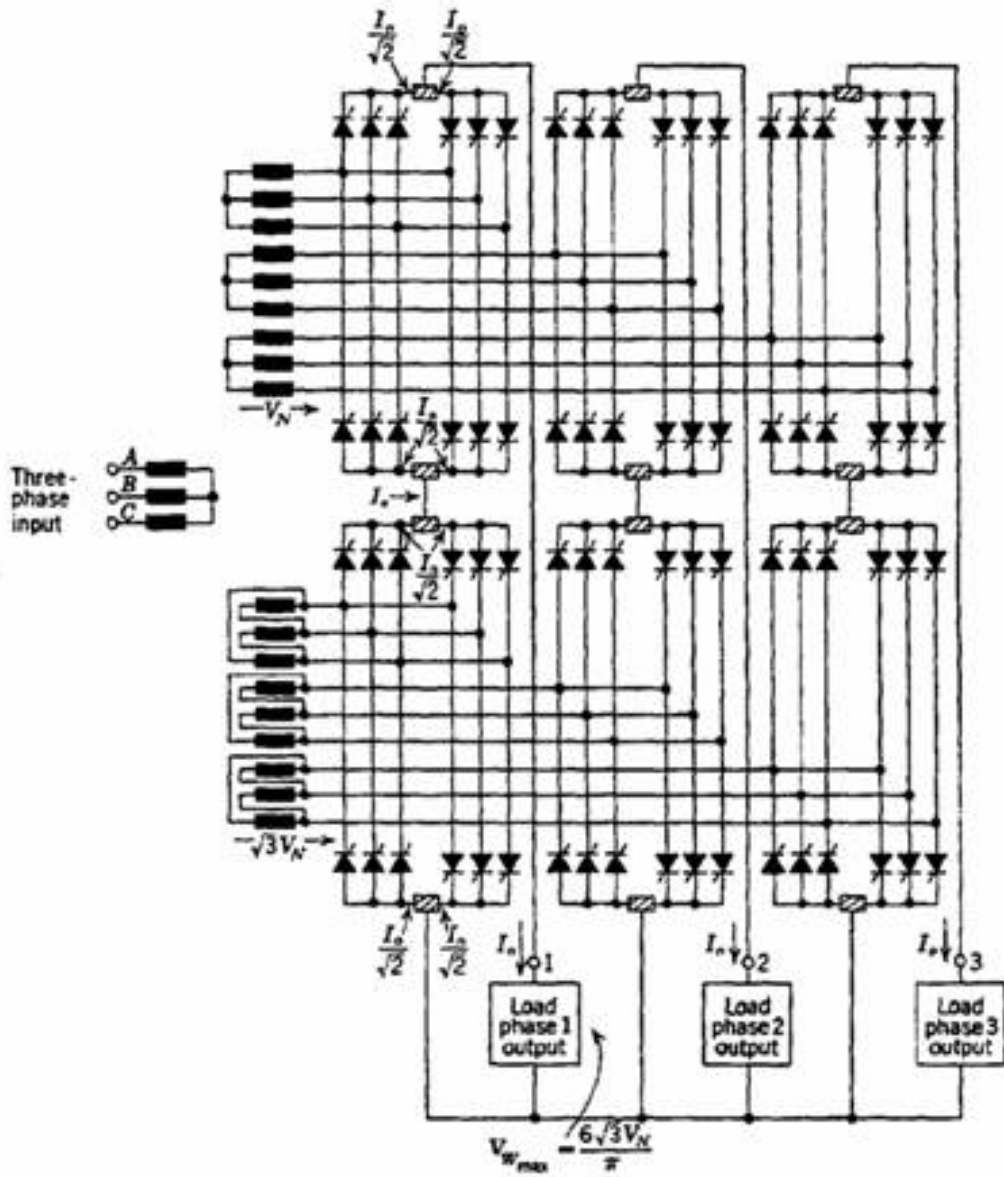

Figure 12. Twelve-Pulse Bridge Cycloconverter [10]

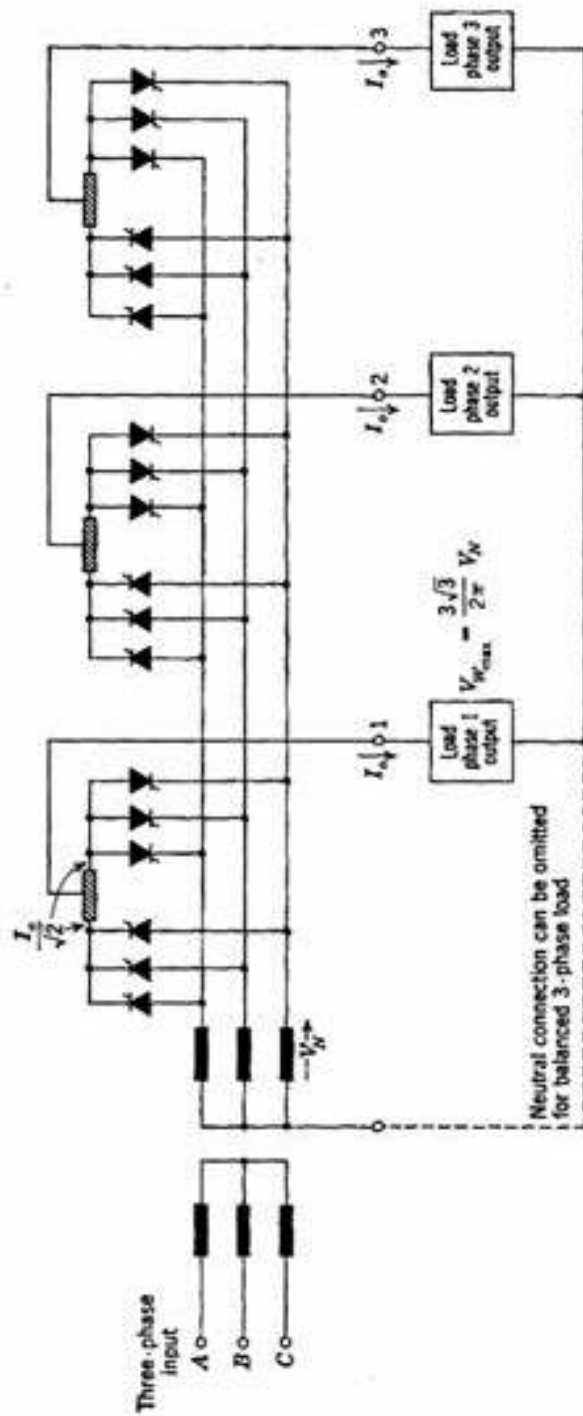

Figure 13. Three-Pulse, Midpoint Cycloconverter [10]

THIS PAGE INTENTIONALLY LEFT BLANK

III. CYCLOCONVERTER CONTROL STRATEGIES

There are many cycloconverter control strategies that have been adopted to eliminate low order harmonics or to increase efficiency during transient conditions. Circulating current buildup, overshoot during start up, and varying load conditions can be detrimental to efficiency and can lead to failure of system components if they occur frequently. Many strategies have been developed to incorporate system feedback to protect the system from transient currents and increase efficiency during transient stages. Optimal control strategy becomes increasingly important if there are no inter-group reactors separating the positive and negative converters from the load to control low order harmonics and prevent shorts across input bus lines.

A. CYCLOCONVERTER OPERATING MODES

Before discussing cycloconverter control strategies it is worth mentioning the two modes of operation of a cycloconverter: blocked and circulating current modes. It was stated in Chapter II that the inclusion or exclusion of the inter-group reactors between the positive and negative converters made a profound difference in harmonics. In addition, this small difference entirely changes the control strategy used in the system.

1. Blocked Mode Cycloconverter

The blocked mode of operation eliminates the bulky inductors between the positive and negative converters and prevents both of the converters from conducting current simultaneously. This primarily reduces both the size and the cost of the cycloconverter. Furthermore this elimination avoids some conduction losses by reducing current to a single converter at a time. The positive converter supplies voltage and current directly to the output for the positive half-cycle and the negative converter supplies voltage and current for the negative half-cycle. A voltage waveform is created at the output that is cut and paste from segments of the positive and negative converters. A sample blocked cycloconverter output is shown in Figure 14. This output waveform is much richer in harmonics than the equivalent cycloconverter output with inter-group reactors shown in Figure 7. Blocked cycloconverters also forces the converter to have a discontinuous current in order to ensure than both converters are not on at the same time.

Using a blocked mode cycloconverter requires either gate turn-off thyristors to force one of the converters off at the appropriate time or further reduction of the efficiency by tampering with optimized controls. Overall, the use of this mode of cycloconverter requires additionally complicated control [13].

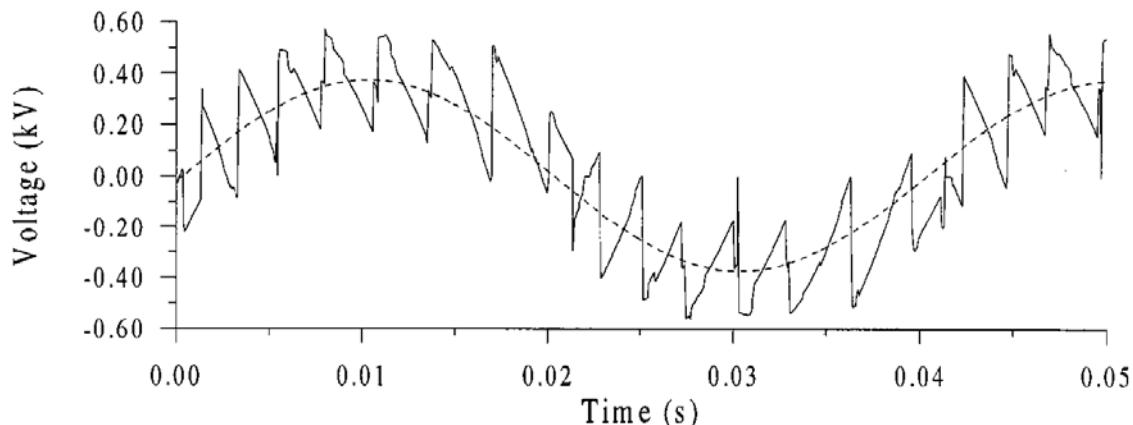

Figure 14. Example Output Voltage of a Blocked Mode Cycloconverter [3]

a. Discontinuous Current

One of the major downfalls of the blocked mode cycloconverter is the necessary addition of discontinuous current. In order to ensure that there is never a time when they are both on, it is mandatory that there be slight pauses where both converters are off. This produces a stoppage in the output current that not only produces additional harmonics, but also voltage sags in the output. For ship drive application, having any discontinuities in the output current is entirely unacceptable [10].

2. Circulating Current Mode

The circulating current mode is the standard mode of operation discussed in Chapter II. An inter-group reactor is included, and allows current to circulate through the positive and negative converters. To keep current flow in both of the converters entirely continuous it is necessary to allow large amounts of circulating current. At times it can reach 57% of the output load current [10].

As stated before, allowing for circulating current reduces the number of harmonics in the output voltage. This mode of operation also simplifies the optimal control strategy for the cycloconverter. Much like a rectifier, circulating current allows the cycloconverter to be controlled with a few inputs into a logic assembly. Only the

three input phase voltages and a sinusoid with the desired output frequency are required. However, this additional current causes excess losses in the semiconductor elements it passes through [10].

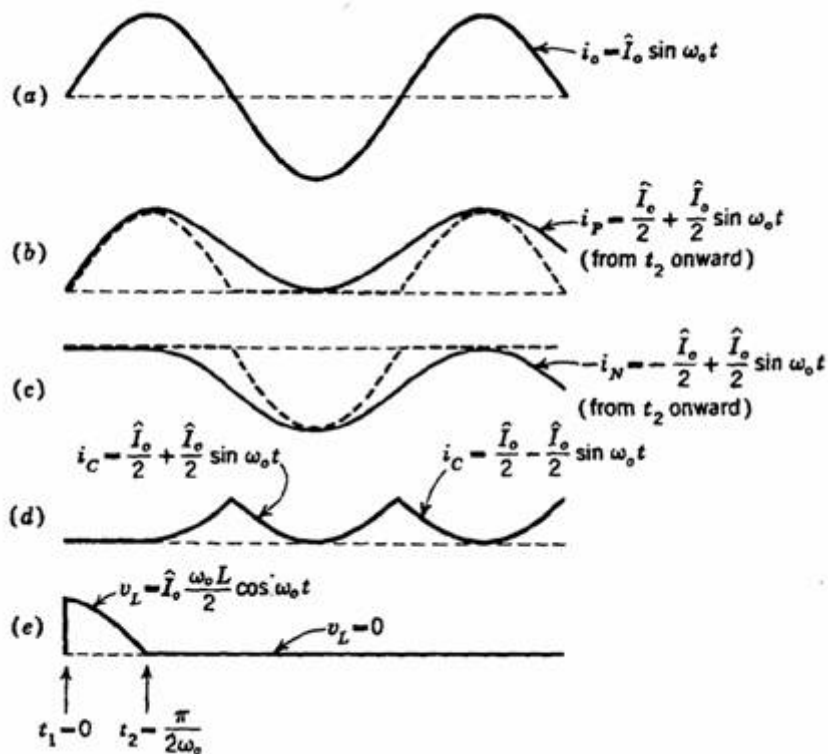

Figure 15. Circulating Current Through a Cycloconverter [10]

Figure 15 shows how this circulating current occurs in a cycloconverter. Figure 15-a is a plot of the ideal output current. Figure 15-b and Figure 15-c show the current flowing through the positive and negative converters respectively. The dotted lines are the ideal current that is transferred to the output, while the solid line shows the current that flows through the converter in order to keep the current in the converters continuous. Figure 15-d shows the difference between the solid and dotted lines which is the current circulating through the two converters. Notice that the circulating current is at a peak when the cycloconverter is switching between the two converters and at a null when a single converter is in full use. Figure 15-e shows the buildup of a voltage on the inter-group reactor during the first quarter cycle. When the negative converter

switches on, and the circulating current begins, this voltage reaches 0, and remains at zero for the entirety of steady state operation [10].

B. COSINE PULSE FIRING METHOD

The cosine pulse firing method of cycloconverter control allows optimal performance in steady state operation for a circulating current mode cycloconverter. It is a simple strategy which does not require feedback loops, although it still accounts for changes in the system input to retain a stable output. In essence this control strategy is the same that is used with voltage controlled rectifiers, although the inputs to the controls are slightly different [10].

1. Voltage Controlled Rectifiers

In a rectifier, a series of diodes or thyristors fire in a set order to produce a DC output. Figure 16 shows a three-phase rectifier bridge and the corresponding diode firing patterns. Notice that each of the diodes is on for 120 degrees at a time, and that at any one time, there are two diodes which are on. The two conducting diodes connect a phase voltage across the load. When D_6 and D_5 are on, V_{CN} is connected to the top of the load and V_{BN} is connected to the bottom of the load. This makes the load across the voltage $V_{CN} - V_{BN}$, or V_{CB} . Voltage controlled rectifiers share many of the same aspects of uncontrolled rectifiers. Each of the switches is still on for 120 degrees, and the firing order remains unchanged. However, the time at which each of the thyristors fires can be delayed to reduce the overall output DC Voltage.

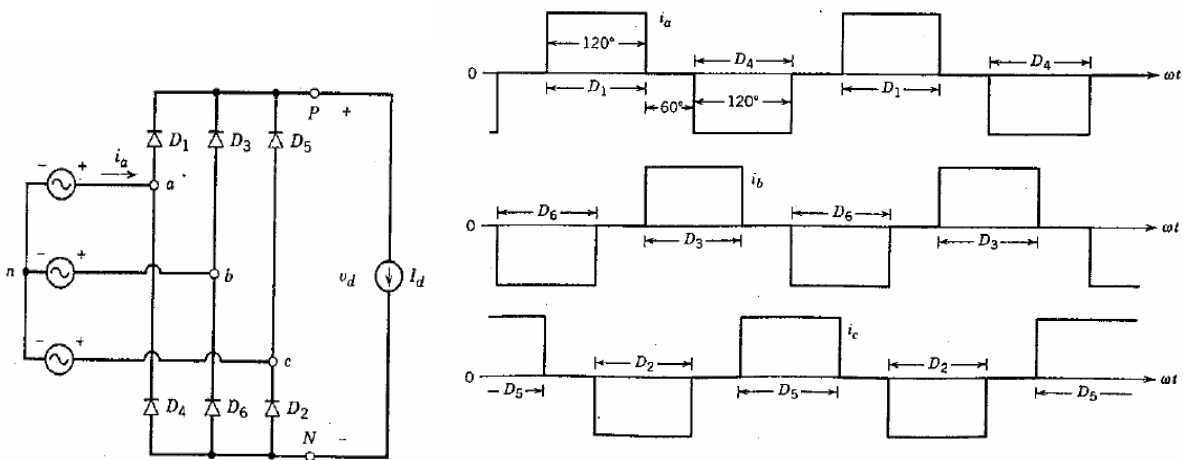

Figure 16. Three-Phase Rectifier and Corresponding Diode Firing Patterns [16]

For a controllable three-phase, full bridge rectifier system, the maximum DC output voltage occurs when all thyristors are triggered exactly 30 degrees prior to their corresponding voltage waveform peaks; when D4 turns on, the phase voltage across the load is V_{BA} , so the maximum output would occur if D4 is turned on exactly 30 degrees before V_{BA} peaks. This position is defined as a firing angle of 0 degrees. As the firing angle is delayed, the amplitude of the output voltage follows a cosine pattern. From the firing angle of 0 degrees, where the output is maximized, the output DC voltage declines until the firing angle reaches 90 degrees, where the DC output is 0 volts. Because the same firing angle occurs in the different places in time for each of the thyristors, a single cosine wave is not sufficient to time each of the devices. Instead, the phase voltages must be shifted back 30 degrees to create the appropriate timing waveform for each thyristor. Luckily, the input line-to-neutral voltages are all exactly 30 degrees shifted from the phase voltages. This allows the timing waveforms to be extracted directly from the line-to-neutral voltages. Figure 17 shows the line-to-neutral voltages V_A and V_B along with the phase voltage V_{BA} , which would be across the load when diode D4 is turned on. Notice that V_B reaches its peak exactly 30 degrees before V_{BA} . Therefore, V_B is the appropriate timing waveform for D4. These timing waveforms are then fed into an op-amp circuit along with a DC reference voltage [16].

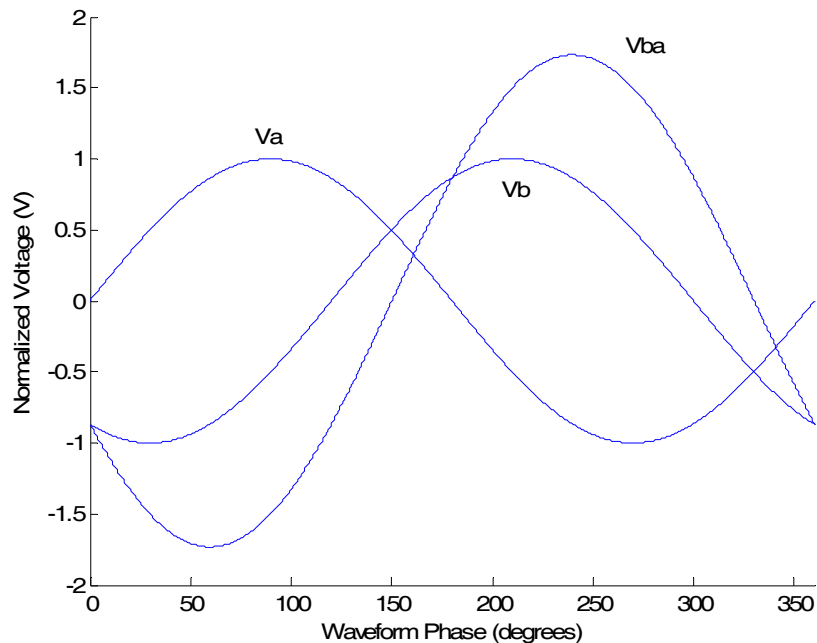

Figure 17. Timing Waveform Example

When the AC timing waveform for a given thyristor is greater than the DC reference, the positive op-amp rail is transferred at the output. When the DC reference is greater, the output of the op-amp switches to the negative rail, usually 0V. Therefore, when the thyristor timing wave crosses the DC reference at a negative slope, the op-amp control produces a negative edge signal which can be used to trigger the thyristor firing. The output of the rectifier circuit is directly proportional to the DC level of the input. The higher the DC value is, the earlier the firing angle and the larger the output voltage. If the DC input is grounded, the firing angle of the thyristors will be 90 degrees, therefore producing a 0 volt DC output [16].

Figure 18 shows an example of how this DC reference works using a rectifier with only three thyristors. Thyristor 1 corresponds to the V_A load voltage, so the timing waveform has been advanced 30 degrees, so that the maximum occurs when the firing angle for thyristor 1 is 0 degrees.

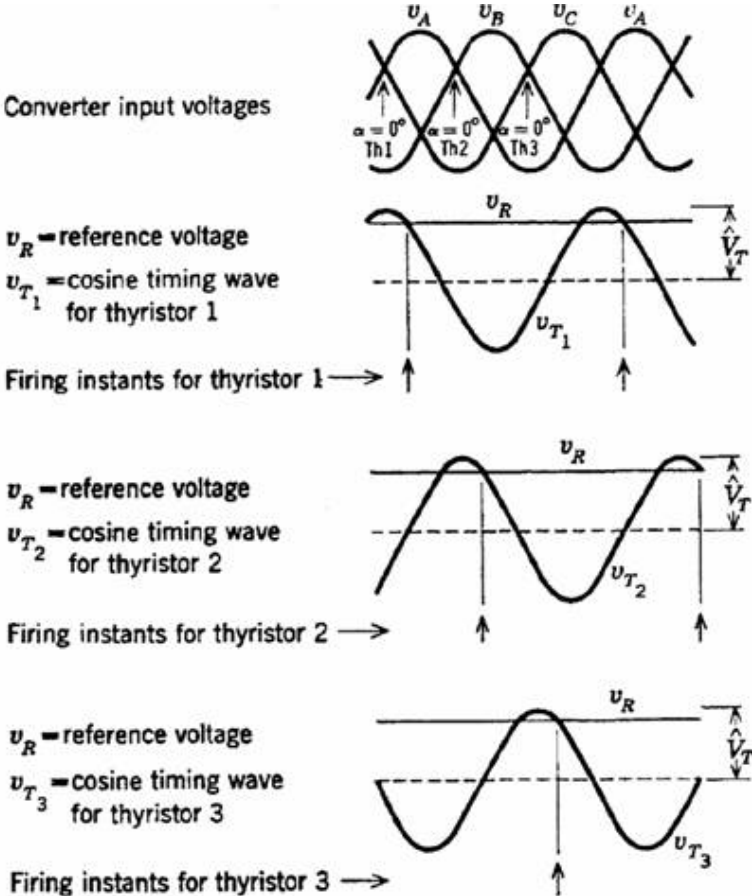

Figure 18. Example of Rectifier Control with DC Reference Voltage [10]

2. Cosine Cycloconverter Control

This same strategy can be applied to the cycloconverter, with the exception that, instead of a DC reference value, a sinusoidal reference value at the desired output frequency is used. This varies the firing angle of each of the thyristors such that the output of the converter is sinusoidal at same frequency as the reference waveform [10].

Using this algorithm, thyristors in the positive converter receives the information to switch on whenever the timing waveforms cross the reference waveform on a negative edge, or when the timing waveform crosses at a negative slope, while the thyristors in the negative converter receives the information to switch when the timing waveform crosses the reference on a positive edge. Though the cosine timing method has no feedback, it is considered to be self-regulating because the timing waveforms are directly obtained from the input voltages. Therefore any change in the inputs will also occur in the timing waveforms. As with the rectifier circuit, the magnitude of the cycloconverter output voltage is directly proportional to the magnitude of the AC input. The larger the voltage of the reference, the higher voltage produced on the output, and higher power quality the output voltage waveform will have [10]. Figure 19 shows the six voltage inputs derived from the three phases of a cycloconverter input. Figure 20 shows the timing waveforms for these six inputs in addition to a sinusoidal reference input. Figure 21 includes the same waveforms, although the timing waveforms have been combined with the reference so that the waveforms trigger the thyristor at a zero voltage crossover.

C. OTHER THYRISTOR FIRING METHODS

Several other techniques apart from the cosine firing method exist for all models of cycloconverters. Obviously, blocked mode cycloconverters cannot use the cosine firing method of control at all because it switches on the positive and the negative converters during the same periods of time. Many control methods simply incorporate the use of different timing waveforms or a closed loop feedback control. One method adds a jitter control feedback, so that the timing waveforms are simply modified slightly in order to eliminate specific harmonics. Many of these methods are desirable for

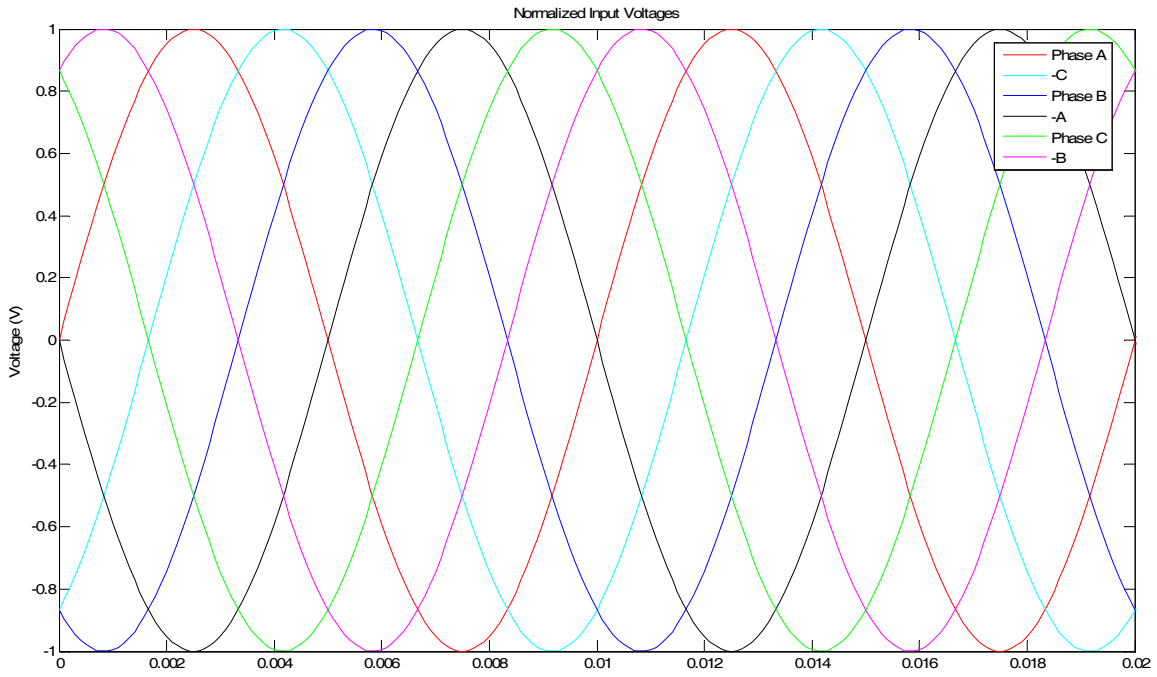

Figure 19. Input Waveforms into Cycloconverter

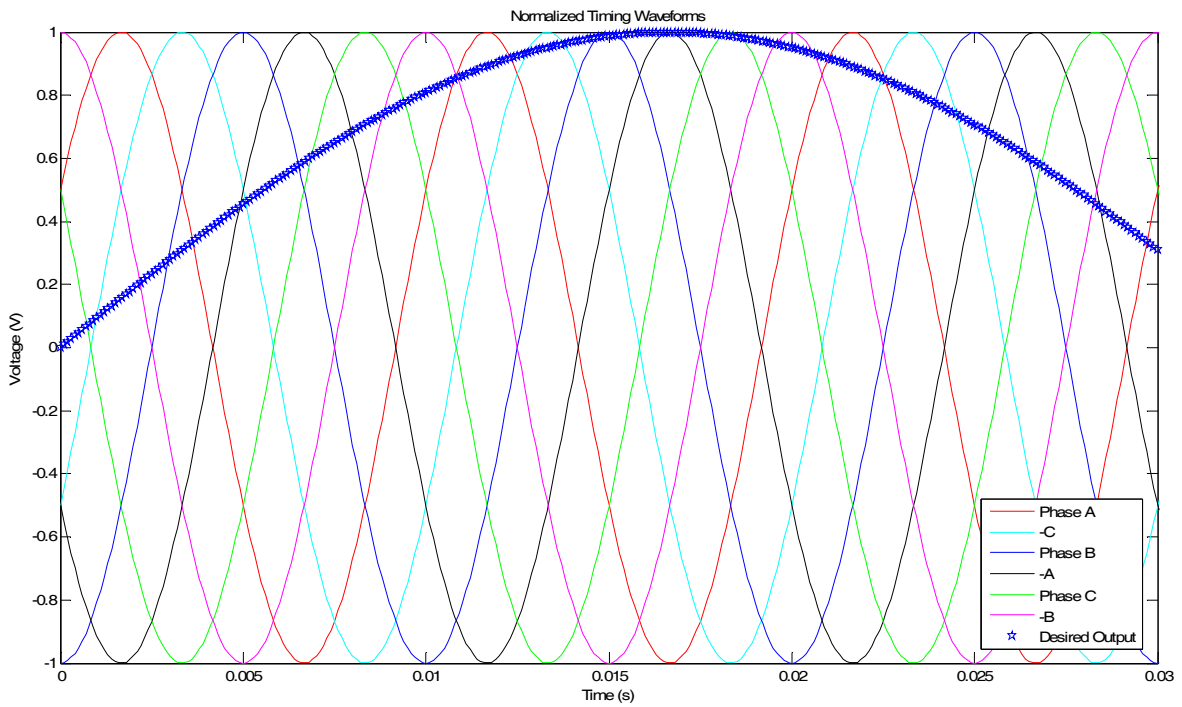

Figure 20. Timing Waveforms and Algorithm Input

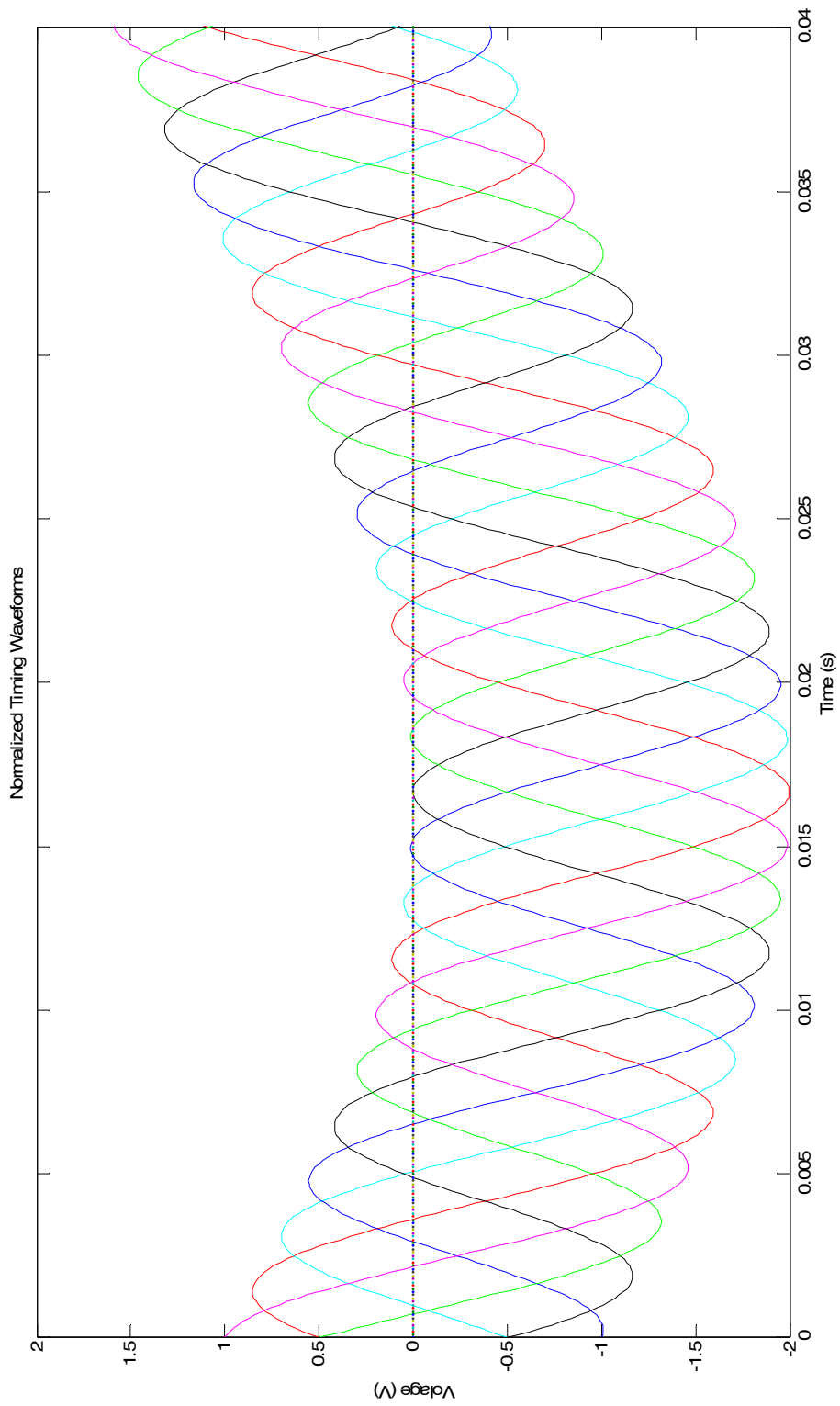

Figure 21. Timing Waveforms with a Zero Voltage Trigger

systems that have large amounts of transient power production. However, regardless of how these other methods work, they will always result in an increase of total output voltage harmonics and input current harmonics for a steady state cycloconverter machine [4,10].

IV. CYCLOCONVERTER SIMULATION

In order to model the effects of the cycloconverter a Matlab™ program using Version 7.0.4 was designed to mimic the cycloconverter process of transferring input segments to each of the cycloconverter outputs. To obtain the output voltage, it is only necessary to simulate a single output, as all three outputs contain the same harmonic frequencies and magnitudes and are not dependent on each other. Therefore, only one cycloconverter branch was simulated for output voltage harmonics. However the input current is dependent on the operation of all three output converters so the whole cycloconverter system was modeled for this purpose. Only data on one of the input phases was extracted for results, as all input phases should contain the same harmonic frequencies and magnitudes as with the output voltages. Code used for modeling the Cycloconverter function has been provided in Appendix A.

A. PURPOSE OF SIMULATION

This simulation program was composed to answer two major questions in order to determine the usefulness of a high frequency cycloconverter. Firstly, the model undertakes to find how varying the input frequency affects the output voltage harmonics. Equation (2.2) shows that if the input frequency is increased, the harmonic frequencies increase accordingly, though this only dictates where those harmonics are placed, not their relative strength. Application of the simulation will show whether these harmonics change magnitude with a higher input frequency. Also, this simulation shows the effects of input frequency on the input current, and whether increasing the input frequency will affect input current harmonics beyond at what frequency they occur which is detailed in Equation (2.5). Since current harmonics cannot be filtered out with load inductance, it is important to know what frequency ratios are best when using a cycloconverter.

B. DISCUSSION OF SIMULATION

This model was constructed in Matlab, using M-files to run the program. The model shows an *ideal* cycloconverter in all respects. Thyristor switches are modeled as lossless, and the inter-group reactors which allow both of the converters to remain on at the same time are modeled as part of the load reactance. Additionally, the simulation assumes an infinite bus supply. Though these are not the conditions that a

cycloconverter would face in a real ship drive application, it follows that if a cycloconverter receives benefits from high frequency inputs in ideal conditions, benefits would still exist in real application conditions. All code is original, composed explicitly for this thesis.

1. Cycloconverter Model

The cycloconverter model is constructed using arrays to carry all of the information. To begin, all of the input voltages are constructed using sinusoids as the input as shown in Figure 19. Rather than producing the line voltages in addition to the phase output voltages, the phase voltages were shifted forward 30 degrees to produce the timing waveforms in Figure 20. The reference waveform is then added, and the timing waveforms are transformed into those in Figure 21. At this point the construction of the output waveforms begins. Boolean variables contain the information of which thyristor in each of the converters has most recently switched on. That thyristor remains on until the firing waveforms crosses the zero boundary at either a positive or negative edge, which fires the next thyristor, automatically turning another of the switches off according to the switching pattern. Again, this thyristor remains on until two more thyristors have been triggered. As each thyristor directly corresponds to one of the phase voltage waveforms, these waveforms are simply translated directly to the output while their corresponding thyristor is on. This produces exactly the “cut and paste” type of waveform that is produced at the outputs of each of the positive and negative converters in the case of a real cycloconverter. Lastly, these waveforms are averaged, an effect that happens because of the inter-group reactor separating them. The inductance acts to sum the integrals of the voltage together, acting in effect as an averaging device.

2. Cycloconverter Output Voltage Simulation

For model verification and results, all three of the outputs of the cycloconverter are studied, the positive output, the negative output, and the combined output which then proceeds to the load. The combined output especially is of interest, because it is the voltage applied to the load. The harmonics in the combined output will cause the torque pulsations in the output motor, and these pulsations are ultimately what need to be filtered or eliminated. Current harmonics are studied as well using the Fast Fourier

Transform subroutine inherent in Matlab. Different frequencies and load power factors are examined in order to find the load distortions. Total Harmonic Distortion is then found using [16]

$$\text{THD} = 100 \sqrt{\sum_{h \neq 1} \left(\frac{I_h}{I_1} \right)^2} \quad (4.1)$$

where I_h are the harmonic currents and I_1 is the fundamental.

3. Cycloconverter Input Current Simulation

Input current simulation for the cycloconverter is trickier than the output. In addition to needing to simulate all three converters to achieve correct results, current only flows from each phase into two of the thyristors in each of the converter bridges. Therefore, the input phase current must be picked carefully while the output waveforms are being constructed.

Harmonics in the input current are studied in the same way as the output harmonics, using the Fast Fourier Transform. Total harmonic distortion is derived from these harmonic results using (4.1).

THIS PAGE INTENTIONALLY LEFT BLANK

V. SIMULATION VERIFICATION

Before examining any of the results, the simulation was verified to correctly model cycloconverter operation by use of the equations and the charts of waveforms and harmonics that are previously included in this thesis. All inputs and outputs were paired with their ideal counterparts to ensure that the model was as closely matched as possible before experimentation data was collected. Data used for model validation was all obtained from Matlab code contained in Appendices B and C.

A. MODEL VERIFICATION

One of the strong points of this simulation is that every waveform that is generated by the cycloconverter, every harmonic graph, and every voltage and current are available for view. This is exceptionally handy for the task of model verification as outputs and inputs are simply graphed from the models, as well as their frequency spectrum, and they can be simply compared to the expected values and figures. Many of the charts and graphs used for verification have already been provided in Chapter II and Chapter III. All of the output data for the model closely matched with preexisting charts and graphs.

B. OUTPUT VERIFICATION

The output waveforms of the cycloconverter were achieved using the techniques described in Chapter IV. Waveforms were collected from the outputs of the positive and negative converter, as well as from the ideal final output of the cycloconverter.

1. Output Voltage Signal Verification

Figure 22 shows the normalized voltage output of the positive converter when the input of the model is 100 Hz and the desired output is at 14 Hz. All of the expectations of the positive converter here have been met. The voltage always jumps to a higher level during each of the switching events. Also, the output is a 14 Hz waveform composed of much higher frequency pieces. Figure 23 shows the output of the negative converter. The only difference between the two being that the negative converter always decreases voltage during each of the switching events.

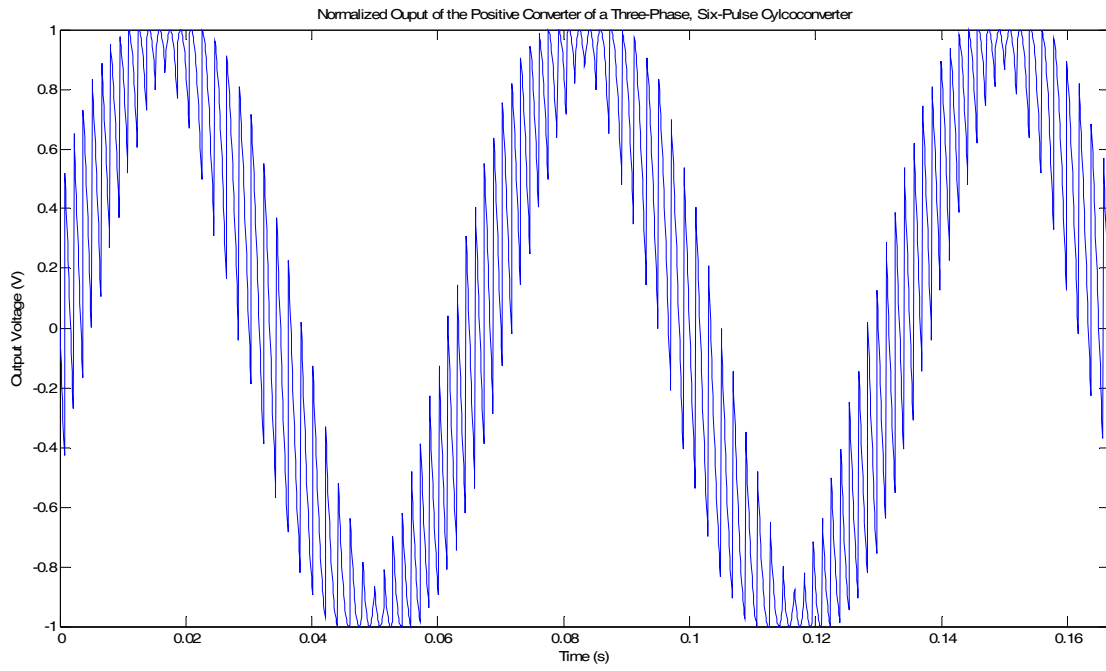

Figure 22. Normalized Output of the Positive Converter

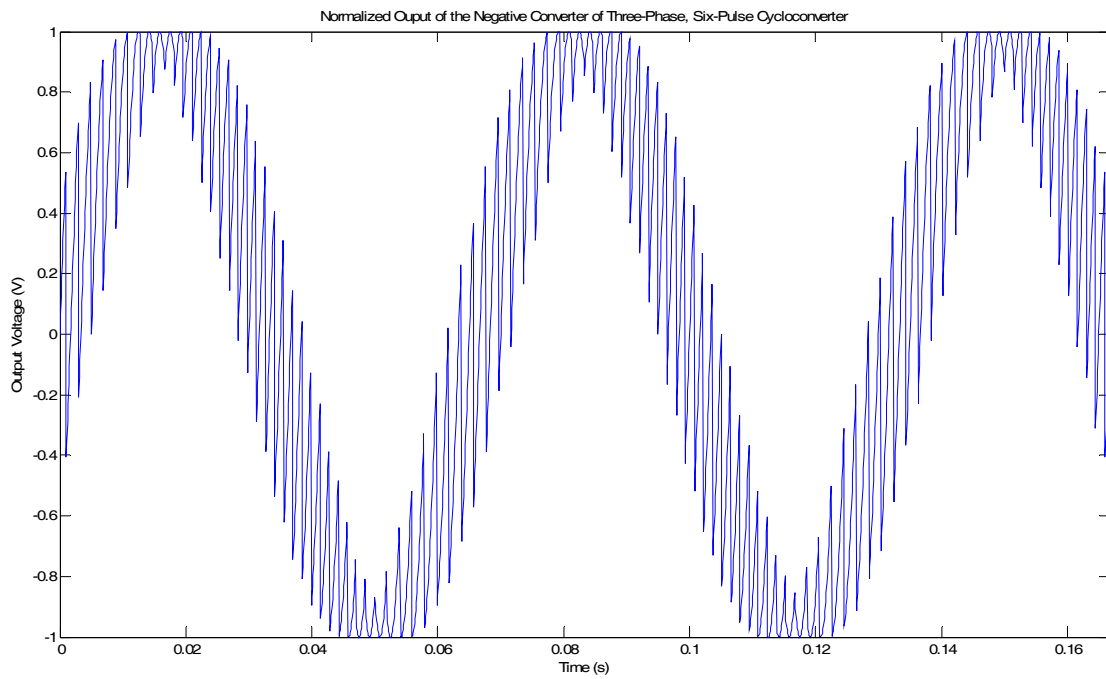

Figure 23. Normalized Output of the Negative Converter

Figure 24 shows the final output of the cycloconverter. Note that this waveform has the same “step levels” as the final output in Figure 7. The only major difference between the two is that the input-to-output ratio is much higher in Figure 24, which creates a sort of pulse width modulation effect – with shorter pulses at the outside corners of each of the steps and longer pulses on the insides. It is important to note that although there is a step effect on the output, and the steps seem to have a PWM like modulation, there are only AC components in the waveform.

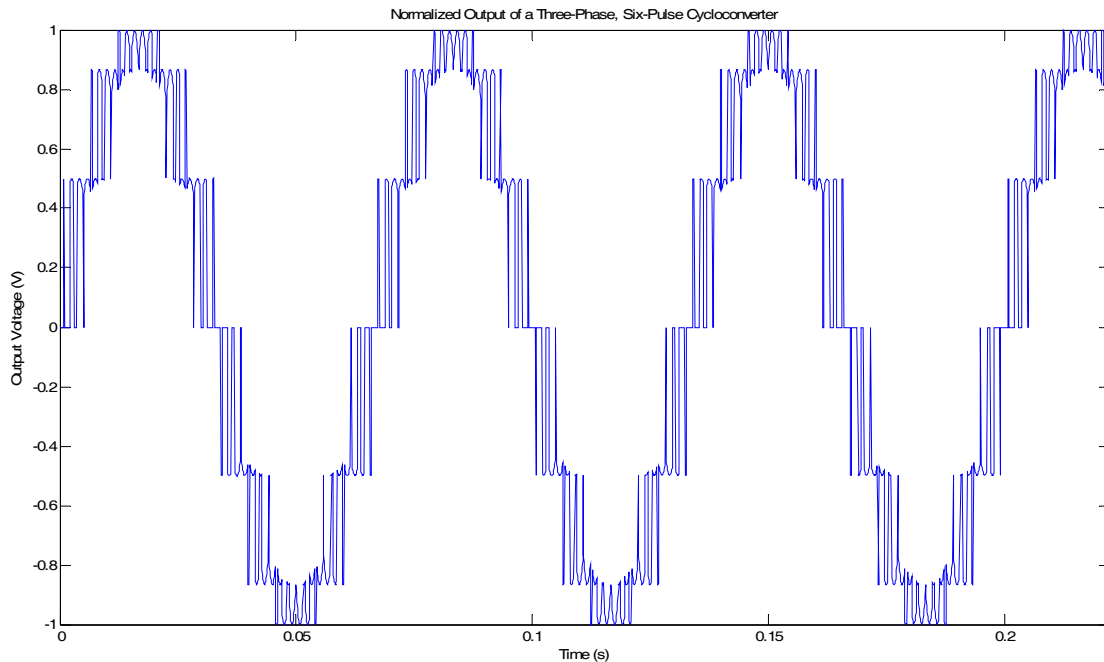

Figure 24. Normalized Output of the Cycloconverter

2. Output Harmonic Verification

The most important test to ensure the validity of the output is to ensure that all of the voltage harmonics occur in the right places. Figure 25, shows the frequency components of the signal modeled in Figure 24. As expected, harmonics occur in a series of expanding windows, rather than single harmonics at specific frequencies. The first harmonic window occurs around 600 Hz, or six times the input frequency. This window is easily distinguished from those other harmonics around it. More harmonic windows then occur at intervals of 600 Hz, and gradually expand as the frequency increases. These harmonics match exactly with expected harmonics, which are found

using Equation (2.2) or in Figure 8. However, because of the blending of the positive and negative converters, some of the harmonics predicted have been cancelled – which explains why more harmonics are predicted by (2.2). The large frequency component at the far left is the fundamental, which occurs at 20 Hz.

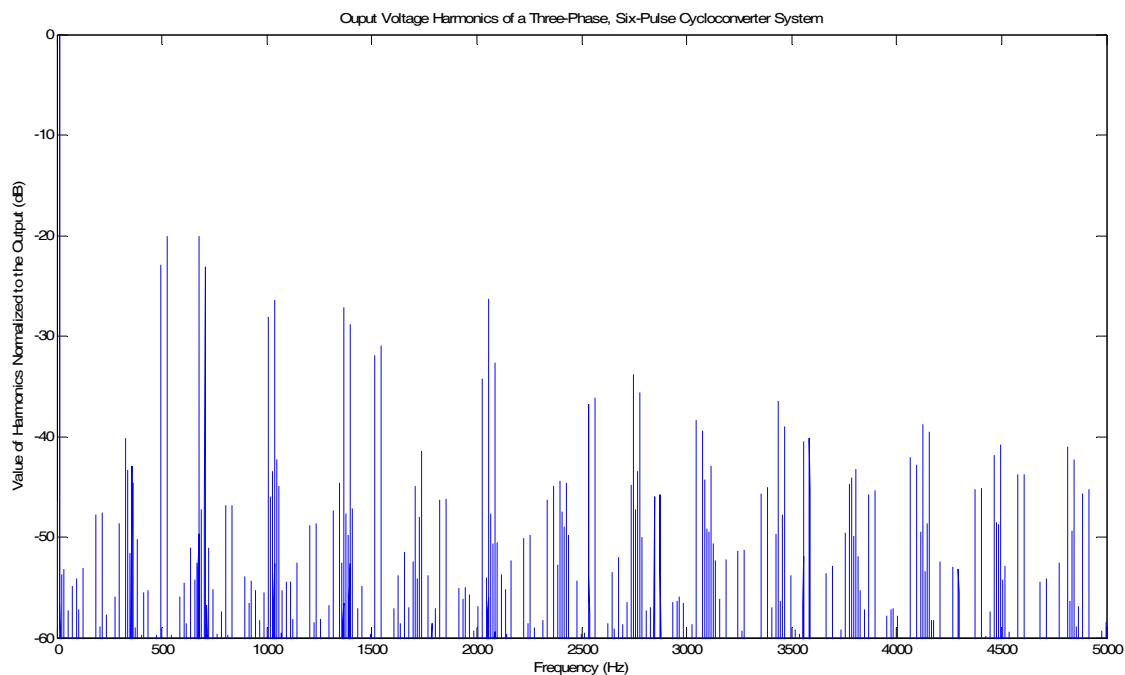

Figure 25. Frequency Spectrum of Cycloconverter With Input Frequency 100 Hz, Output Frequency 14 Hz

C. INPUT HARMONIC VERIFICATION

The expected input current waveforms often do not have a very natural or recognizable look, although the location of the frequency components can always be described by (2.3) and (2.5). These equations show the same type of harmonic frequency windows, though occurring around the fundamental and then at intervals of $6f_i \pm 1$. Figure 26 and Figure 27 show the input current harmonic spectra from both the positive and negative converters while the input of the system is 200 Hz and the output is 14Hz. These frequency spectra are for all purposes identical in magnitude, though the phases of these frequency components are different and when both are added together by superposition, some cancellation occurs. Figure 26 and Figure 27 as well exactly match with those harmonic frequencies predicted by closed form equations.

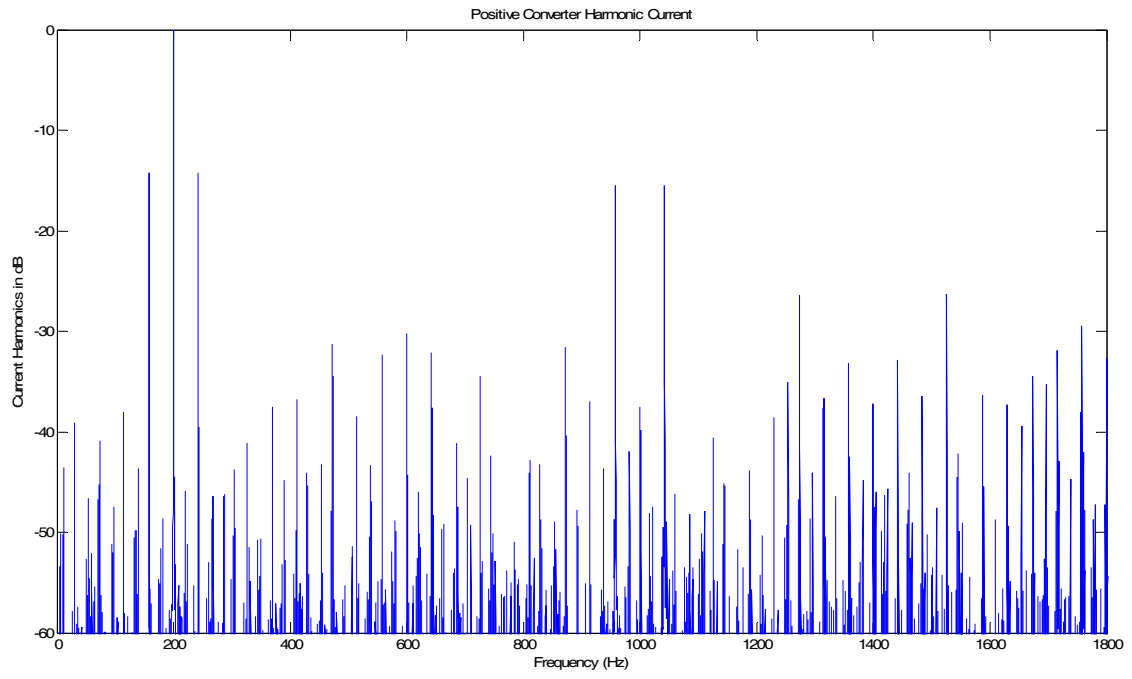

Figure 26. Positive Converter Harmonic Current

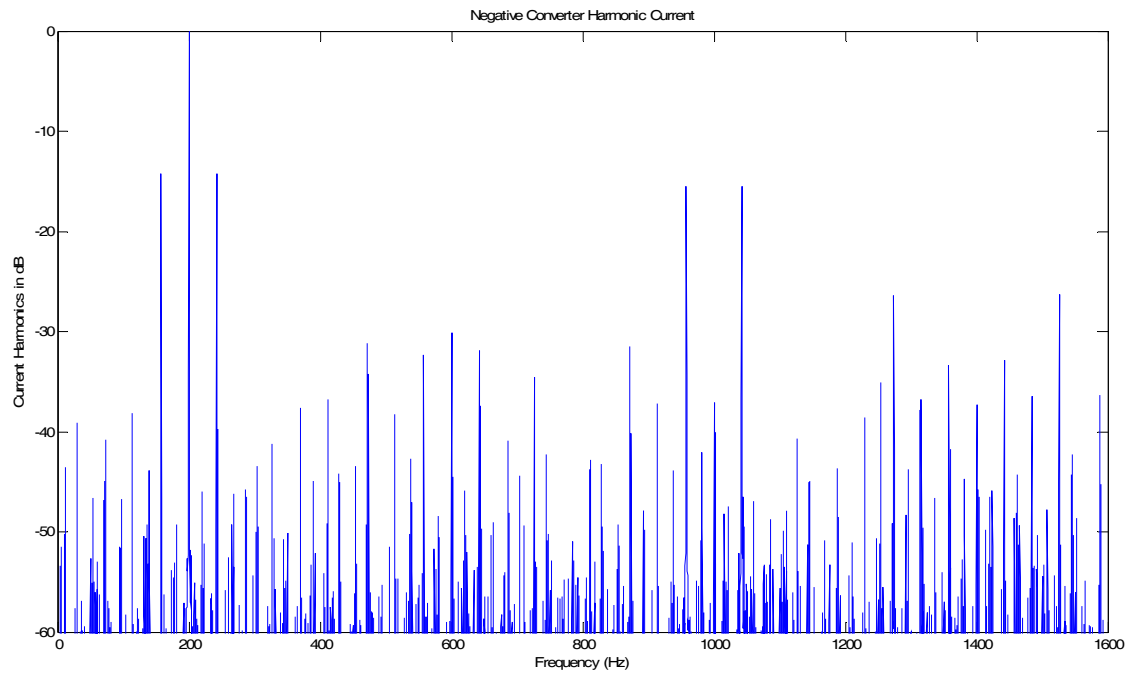

Figure 27. Negative Converter Harmonic Current

These results show that the model does indeed portray accurate input and output effects of the cycloconverter. This model can now be used to provide data about the total harmonic distortion both of the output voltage and current, and the input current.

VI. RESULTS OF SIMULATION

The results of the simulation were obtained from the harmonic content of the output and input signals. This data was all modified and plotted within the Matlab Program. The code for obtaining THD has been provided in Appendices B and C.

A. PERFORMANCE OF OUTPUT VOLTAGE HARMONICS

One of the questions originally posed by this thesis is whether using a high input-to-output frequency ratio would actually reduce voltage harmonics or whether the higher ratio would simply push the harmonics to higher frequencies. The results shown in Figure 28 seem to provide a fairly clear answer to this question. Moving from a ratio of less than two to a ratio of greater than 14, the voltage distortion drops less than two percent, although it seems to be on a slow but steady decline. Unfortunately, this continuous drop does not suggest that the harmonics are actually being reduced. Because the model does not produce an infinitely long signal, the frequency spectrum created by the Matlab program is also finite. The models produced in this code can only detect frequency components up to 25 kHz. As the input frequency is being increased, larger harmonics are being pushed out of the frequency bounds and are no longer included as harmonic distortion. Though these larger frequency harmonics are small, they still slightly impact the overall distortion of the output signal. Therefore, the actual amount and magnitude of the harmonics are not being decreased, only the frequency at which harmonics occur.

Figure 28, does show however what the effects are on the output current distortion. As the load is filtered with larger and larger amounts of inductance the current distortion decreases rapidly. Even at the near unity power factor of 0.99 lagging the improvement is remarkable from the voltage harmonics. As the frequency ratio is increased, the distortion drops even further. This trend is shown more clearly in Figure 29, which is a closer look at the same information held in Figure 28. At a power factor of 0.99 lagging the change from the input-to-output frequency ratio of 1.4 to 4 reduces harmonic distortion from 6% to less than 1.5%. For loads that require high quality power, this small change in the input frequency allows for a huge change in load inductance.

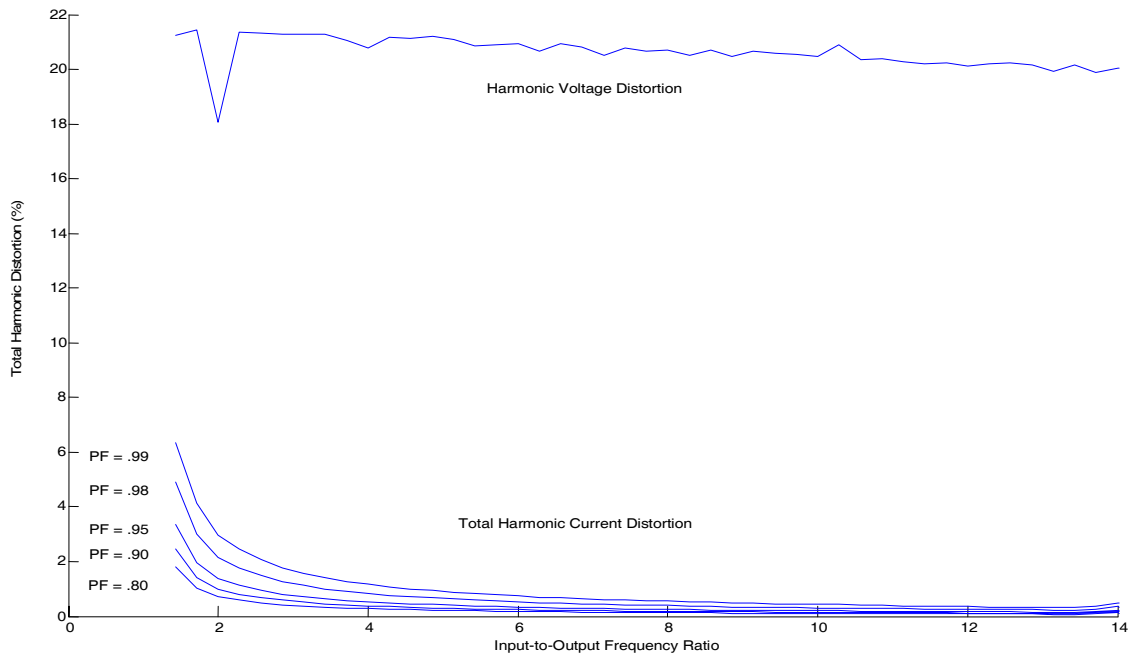

Figure 28. Output Total Harmonic Distortion of a Cycloconverter

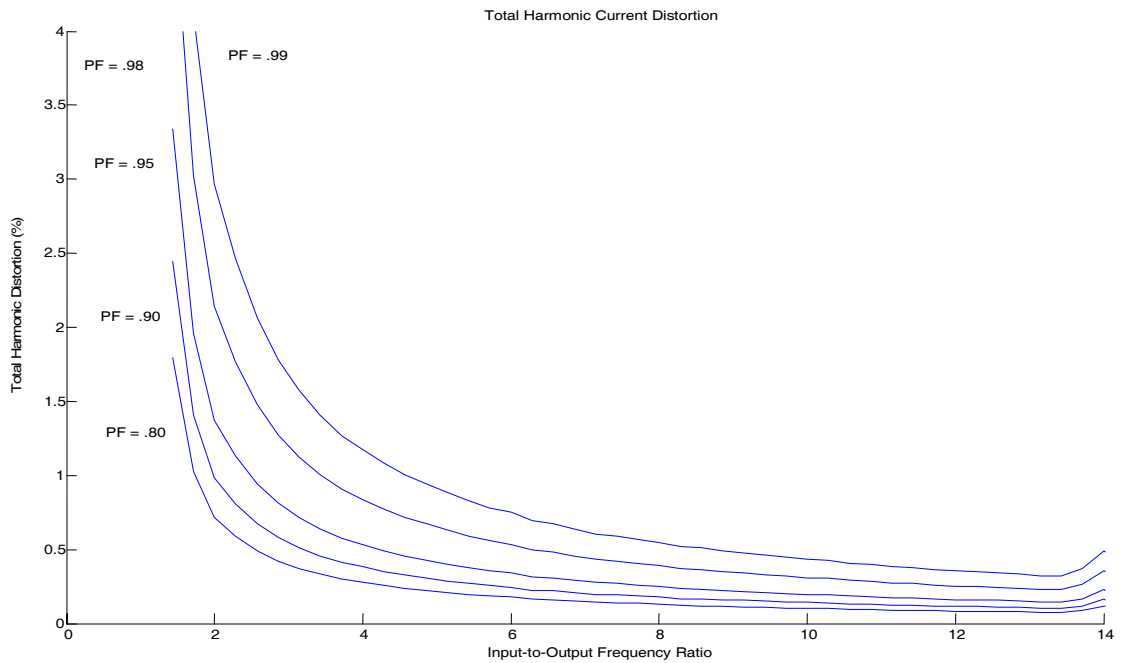

Figure 29. Output Current Total Harmonic Distortion of a Cycloconverter

However, the improvement in harmonic distortion drops off rapidly as the input-to-output frequency ratio increases. Further increases to the input frequency at input-to-output ratio to six seem to garner little results, although at high power factor loads, the improvement is still noticeable.

B. PERFORMANCE OF INPUT CURRENT HARMONICS

The cycloconverter method of producing an output signal with a lower frequency than the input produces several strains on the input of the system. On an infinite bus system the voltage is fixed, though the current is vulnerable to distortions produced by switching devices on and off. Unfortunately, due to the non-linear nature of the system, the reactance of the load can not be accounted for when measuring the input currents of the system. This omission leaves the simulation somewhat wanting. The simulation can show the input current behavior of a cycloconverter performing without circulating current, though that has not been the purpose of this thesis. Instead, the currents moving through both of the positive and negative converters have been added without adding the effect of inductance, which will not show the actual harmonic content of the input current, but should provide the same trend in total harmonic distortion as if the reactive effects were present.

Figure 30 shows the harmonic distortion on a single phase of the input current of the positive converter; Figure 31 shows the harmonic distortion on a single phase of the input current of the negative converter. If these two converters were being used one at a time as in the blocked mode case, these graphs would closely resemble the real harmonic distortion on the input of the system. However, because of the circulating current in cycloconverter usage, many of the harmonics that occur in the input current are circulated through the two converters, rather than being drawn from the input. Figure 32 shows the harmonics present only in the input when the positive and negative converters are circulating. This drastically reduces the harmonic present on the input current. The true total harmonic distortion of the cycloconverter in circulating mode would be larger than this, though the trend would follow the same pattern.

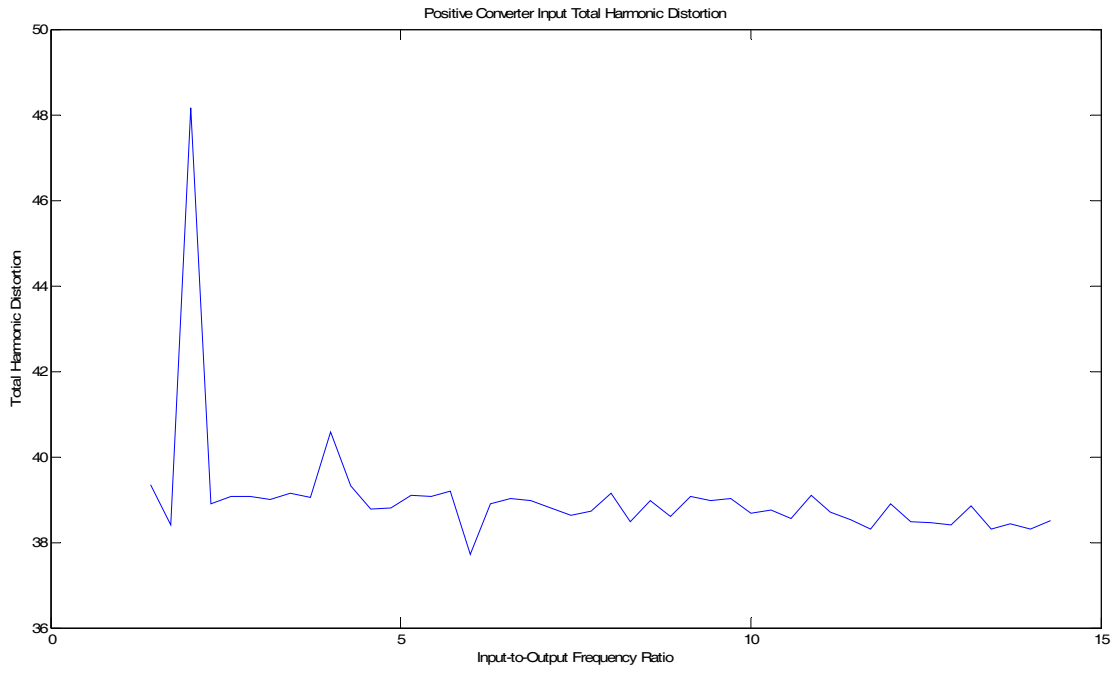

Figure 30. Positive Converter Input Current Total Harmonic Distortion

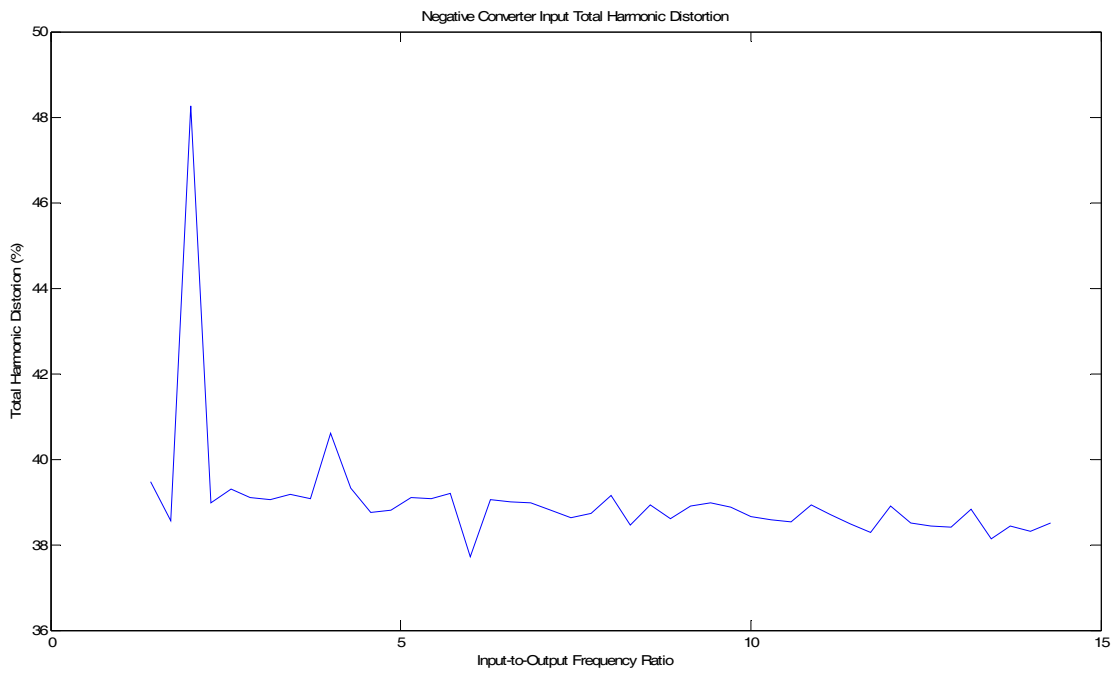

Figure 31. Negative Converter Input Current Total Harmonic Distortion

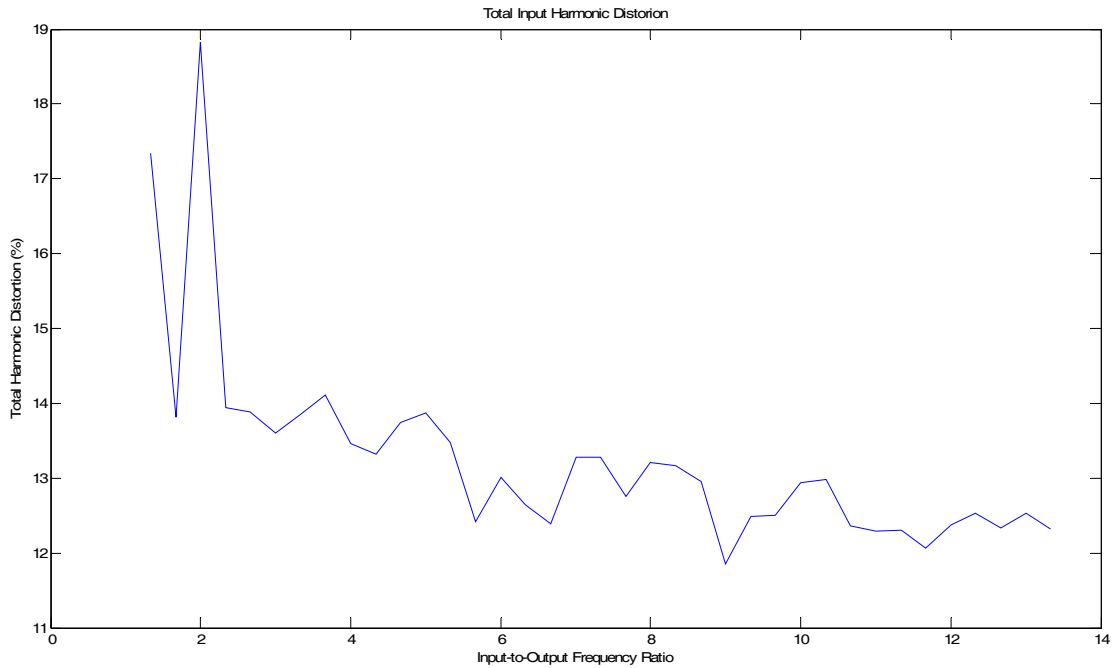

Figure 32. Combined Converters Input Current Total Harmonic Distortion

Neither the positive nor the negative converter input harmonics seem to drop appreciably as the input-to-output frequency ratio increases. The slight decreases that are seen can be attributed to large harmonics traveling outside the 25 kHz frequency range of the program. Neither does the combined input harmonic current seem to diminish. It can only be interpreted from this data that a large input-to-output frequency ratio does not generally improve input current harmonics.

There does seem to be an anomaly that occurs at the input-to-output frequency ratio of 2. Both the positive and negative converters have a huge jump in harmonics at this point. Even the combined current shows this large harmonic spike. Also, this spike in input current corresponds to a trough in output voltage harmonics which can be seen in Figure 28. This test was completed at several output frequencies and there was a consistent trend in large harmonic spikes at the input-to-output frequency ratio of two.

C. SUMMARY

This programmed model of the cycloconverter shows that there are great benefits in output current harmonic content as the input-to-output frequency ratio is increased for a standard circulating current mode cycloconverter. This improvement can allow for decreasing load reactance if the load is harmonic sensitive. If load reactance is left as is, this performance improvement will simply translate to fewer torque pulsations on a motor load. However, the increase of input-to-output frequency ratio does not significantly improve the magnitudes of output voltage harmonics, or input current harmonics. Further research can be conducted in order to further validate the results of the computer model and to see the true effects of a high frequency cycloconverter on the input and the output of the system.

APPENDIX A. MATLAB CYCLOCONVERTER TEST PROGRAM

```
%Jonathan Gilliom
%Thesis test script
%Last Revised 1 MAY 06

clear all

format compact

format short

%information about input waveforms

timestep = .0001;

stop = 5;

start = 0;

steps = (stop-start)/timestep+1;

f = 100;

t = [start:timestep:stop];

A = sin(2*pi*f*t);

B = sin(2*pi*f*t-2*pi/3);

C = sin(2*pi*f*t+2*pi/3);

%reference voltage for cycloconverter control

tf = 15;

ref = sin(2*pi*tf*t);
```

```

%Load of Cycloconverter

R = 4;

L = 0;

%triggering waveforms, normalized to 1

Trigger1 = sin(2*pi*f*t+pi/6);
Trigger2 = -sin(2*pi*f*t+5*pi/6);
Trigger3 = sin(2*pi*f*t-pi/2);
Trigger4 = -sin(2*pi*f*t+pi/6);
Trigger5 = sin(2*pi*f*t+5*pi/6);
Trigger6 = -sin(2*pi*f*t-pi/2);

T1 = Trigger1-ref;
T2 = Trigger2-ref;
T3 = Trigger3-ref;
T4 = Trigger4-ref;
T5 = Trigger5-ref;
T6 = Trigger6-ref;

figure (1);

plot(t,A,'r');

hold on;

plot(t,-C,'c');

```

```
plot(t,B,'blue');  
plot(t,-A,'k');  
plot(t,C,'green');  
plot(t,-B,'m');  
axis([0 .1 -1 1]);  
hold off;
```

```
figure (2);  
plot(t,Trigger1,'r');  
hold on;  
plot(t,Trigger2,'c');  
plot(t,Trigger3,'blue');  
plot(t,Trigger4,'k');  
plot(t,Trigger5,'green');  
plot(t,Trigger6,'m');  
plot(t,ref,'p');  
axis([0 .06 -1 1]);  
hold off;
```

```
figure (3);  
plot(t,T1,'r');  
hold on;  
plot(t,T2,'c');  
plot(t,T3,'blue');
```



```
plot(t,T4,'k');
plot(t,T5,'green');
plot(t,T6,'m');
plot(t,0);
axis([0 .04 -2 2]);
hold off;

% Trigger states, these show which SCR's are currently on, also set initial
% conditions. Assume the converter starts entirely off.

TR1 = false;
TR2 = false;
TR3 = false;
TR4 = false;
TR5 = false;
TR6 = false;

TN1 = false;
TN2 = false;
TN3 = false;
TN4 = false;
TN5 = false;
TN6 = false;

poswaveform = [];
```

```

negwaveform = [];

for kk = 1:steps

    % Positive converter steps

    % first step

    if kk == 1

        poswaveform(kk) = -A(kk);

        TR5 = true;

    % switching to T5 (C voltage)

    elseif TR5 == true;

        if T5(kk) <= .0005 && T5(kk) < T5(kk-1);

            poswaveform(kk) = C(kk);

            TR5 = false;

            TR6 = true;

        elseif poswaveform(kk-1) == -A(kk-1);

            poswaveform(kk) = -A(kk);

        elseif poswaveform(kk-1) == 0;

            poswaveform(kk) = 0;

        end

    % switching to T6 (-B voltage)

    elseif TR6 == true;

```

```

if T6(kk) <= .0005 && T6(kk) < T6(kk-1);
    poswaveform(kk) = -B(kk);
    TR6 = false;
    TR1 = true;
elseif poswaveform(kk-1) == C(kk-1);
    poswaveform(kk) = C(kk);
elseif poswaveform(kk-1) == 0;
    poswaveform(kk) = 0;
end

```

% switching to T1 (A voltage)

```

elseif TR1 == true;
    if T1(kk) <= 0.0005 && T1(kk) < T1(kk-1);
        poswaveform(kk)=A(kk);
        TR1 = false;
        TR2 = true;
    elseif poswaveform(kk-1) == -B(kk-1);
        poswaveform(kk) = -B(kk);
    elseif poswaveform(kk-1) == 0;
        poswaveform(kk) = 0;
    end

```

% switching to T2 (-C voltage)

```

elseif TR2 == true;

```

```

if T2(kk) <= 0.0005 && T2(kk) < T2(kk-1);
    poswaveform(kk) = -C(kk);
    TR2 = false;
    TR3 = true;
elseif poswaveform(kk-1) == A(kk-1);
    poswaveform(kk) = A(kk);
elseif poswaveform (kk-1) == 0;
    poswaveform(kk) = 0;
end

```

% switching to T3 (B voltage)

```

elseif TR3 == true;
    if T3(kk) <= 0.0005 && T3(kk) < T3(kk-1);
        poswaveform(kk) = B(kk);
        TR3 = false;
        TR4 = true;
    elseif poswaveform(kk-1) == -C(kk-1);
        poswaveform(kk) = -C(kk);
    elseif poswaveform (kk-1) == 0;
        poswaveform(kk) = 0;
    end

```

% switching to T4 (-A voltage)

```

elseif TR4 == true;

```

```

if T4(kk) <= 0.0005 && T4(kk) < T4(kk-1);
    poswaveform(kk) = -A(kk);
    TR4 = false;
    TR5 = true;
elseif poswaveform(kk-1) == B(kk-1);
    poswaveform(kk) = B(kk);
elseif poswaveform (kk-1) == 0;
    poswaveform(kk) = 0;
end
end
end

```

```

% Negative converter steps

```

```

% first step

```

```

if kk == 1

```

```

    negwaveform(kk) = A(kk);

```

```

    TN2 = true;

```

```

% switching to T2 (-C voltage)

```

```

elseif TN2 == true;

```

```

    if T2(kk) >= -0.0005 && T2(kk) > T2(kk-1);

```

```

        negwaveform(kk) = -C(kk);

```

```

        TN2 = false;

```

```

        TN3 = true;

```

```

    elseif negwaveform(kk-1) == A(kk-1);

```

```
    negwaveform(kk) = A(kk);  
elseif negwaveform (kk-1) == 0;  
    negwaveform(kk) = 0;  
end
```

```
% switching to T3 (B voltage)
```

```
elseif TN3 == true;  
    if T3(kk) >= -0.0005 && T3(kk) > T3(kk-1);  
        negwaveform(kk) = B(kk);  
        TN3 = false;  
        TN4 = true;  
    elseif negwaveform(kk-1) == -C(kk-1);  
        negwaveform(kk) = -C(kk);  
    elseif negwaveform (kk-1) == 0;  
        negwaveform(kk) = 0;  
    end
```

```
% switching to T4 (-A voltage)
```

```
elseif TN4 == true;  
    if T4(kk) >= -0.0005 && T4(kk) > T4(kk-1);  
        negwaveform(kk) = -A(kk);  
        TN4 = false;  
        TN5 = true;  
    elseif negwaveform(kk-1) == B(kk-1);
```

```
    negwaveform(kk) = B(kk);  
elseif negwaveform (kk-1) == 0;  
    negwaveform(kk) = 0;  
end
```

```
% switching to T5 (C voltage)
```

```
elseif TN5 == true;  
    if T5(kk) >= -0.0005 && T5(kk) > T5(kk-1);  
        negwaveform(kk) = C(kk);  
        TN5 = false;  
        TN6 = true;  
    elseif negwaveform(kk-1) == -A(kk-1);  
        negwaveform(kk) = -A(kk);  
    elseif negwaveform(kk-1) == 0;  
        negwaveform(kk) = 0;  
    end
```

```
% switching to T6 (-B voltage)
```

```
elseif TN6 == true;  
    if T6(kk) >= -0.0005 && T6(kk) > T6(kk-1);  
        negwaveform(kk) = -B(kk);  
        TN6 = false;  
        TN1 = true;  
    elseif negwaveform(kk-1) == C(kk-1);
```

```

        negwaveform(kk) = C(kk);
elseif negwaveform(kk-1) == 0;
    negwaveform(kk) = 0;
end

% switching to T1 (A voltage)
elseif TN1 == true;
    if T1(kk) >= -0.0005 && T1(kk) > T1(kk-1);
        negwaveform(kk)=A(kk);
        TN1 = false;
        TN2 = true;
    elseif negwaveform(kk-1) == -B(kk-1);
        negwaveform(kk) = -B(kk);
    elseif negwaveform (kk-1) == 0;
        negwaveform(kk) = 0;
    end
end
end

end

figure (4);
plot(t,poswaveform);
axis([0 10/tf -1 1]);

figure (5);

```



```

plot(t,negwaveform);

axis([0 10/TF -1 1]);

out = (poswaveform+negwaveform)/2;

figure (6);

plot(t,out);

axis([0 10/TF -1 1]);

% transformP = fft(poswaveform)/((stop-start)/timestep);
% transformN = fft(negwaveform)/((stop-start)/timestep);
transform = abs((fft(out)/((stop-start)/timestep)));

Z = [];

for oo = 1:steps

    Z(oo) = sqrt(R^2+(2*pi*(oo-1)/5*L)^2);

end

current = transform./Z;

current = 20*log10((current)/max(current));

transform = 20*log10((transform)/max(transform));

figure (7);

fg=1/timestep*(0:(steps-1)/2)/((stop-start)/timestep);

```

```
plot(fg,transform(1:25001));
```

```
axis([0 5000 -100 0]);
```

```
figure (8);
```

```
plot(fg,current(1:25001));
```

```
axis([0 5000 -100 0]);
```

THIS PAGE INTENTIONALLY LEFT BLANK

APPENDIX B. MATLAB OUTPUT TOTAL HARMONIC DISTORTION TEST PROGRAM

```
%Jonathan Gilliom  
  
%Thesis THD Solving script  
  
%Last revised 4 MAY 06  
  
  
hold on  
  
format compact  
  
format short  
  
  
%information about input waveforms  
  
timestep = .0001;  
  
stop = 5;  
  
start = 0;  
  
steps = (stop-start)/timestep+1;  
  
tf = 14;  
  
t = [start:timestep:stop];  
  
ref = .99*sin(2*pi*tf*t);  
  
ii = 1;  
  
  
%Load of Cycloconverter  
  
R = 4;  
  
L = .00;  
  
imp = L*2*pi*tf;
```

```
theta = atan(imp/R); %use atan -- assume R is positive
```

```
PF = cos(theta)
```

```
for jj = 20:4:200
```

```
%reference voltage for cycloconverter control
```

```
f = jj;
```

```
A = sin(2*pi*f*t);
```

```
B = sin(2*pi*f*t-2*pi/3);
```

```
C = sin(2*pi*f*t+2*pi/3);
```

```
%triggering waveforms, normalized to 1
```

```
Trigger1 = sin(2*pi*f*t+pi/6);
```

```
Trigger2 = -sin(2*pi*f*t+5*pi/6);
```

```
Trigger3 = sin(2*pi*f*t-pi/2);
```

```
Trigger4 = -sin(2*pi*f*t+pi/6);
```

```
Trigger5 = sin(2*pi*f*t+5*pi/6);
```

```
Trigger6 = -sin(2*pi*f*t-pi/2);
```

```
T1 = Trigger1-ref;
```

```
T2 = Trigger2-ref;
```

```
T3 = Trigger3-ref;
```

```
T4 = Trigger4-ref;
```

```
T5 = Trigger5-ref;
```

```
T6 = Trigger6-ref;
```

```
%Graphical representation of input signals, displayed on test file
```

```
% figure (1);  
  
% plot(t,A,'r');  
  
% hold on;  
  
% plot(t,-C,'c');  
  
% plot(t,B,'blue');  
  
% plot(t,-A,'k');  
  
% plot(t,C,'green');  
  
% plot(t,-B,'m');  
  
% hold off;  
  
%  
  
% figure (2);  
  
% plot(t,Trigger1,'r');  
  
% hold on;  
  
% plot(t,Trigger2,'c');  
  
% plot(t,Trigger3,'blue');  
  
% plot(t,Trigger4,'k');  
  
% plot(t,Trigger5,'green');  
  
% plot(t,Trigger6,'m');  
  
% plot(t,ref,'p');  
  
% hold off;  
  
%
```

```

% figure (3);
% plot(t,T1,'r');
% hold on;
% plot(t,T2,'c');
% plot(t,T3,'blue');
% plot(t,T4,'k');
% plot(t,T5,'green');
% plot(t,T6,'m');
% plot(t,0);
% hold off;

% Trigger states, these show which SCR's are currently on, also set initial
% conditions. Assume the converter starts at positive Converter input of
% -A and a negative converter input of A. This starts output at a sin wave

TR1 = false;
TR2 = false;
TR3 = false;
TR4 = false;
TR5 = false;
TR6 = false;
TN1 = false;
TN2 = false;
TN3 = false;

```

```
TN4 = false;
```

```
TN5 = false;
```

```
TN6 = false;
```

```
poswaveform = [];
```

```
negwaveform = [];
```

```
for kk = 1:steps
```

```
    % Positive converter steps
```

```
    % first step
```

```
    if kk == 1
```

```
        poswaveform(kk) = -A(kk);
```

```
        TR5 = true;
```

```
    % switching to T5 (C voltage)
```

```
    elseif TR5 == true;
```

```
        if T5(kk) <= .0005 && T5(kk) < T5(kk-1);
```

```
            poswaveform(kk) = C(kk);
```

```
            TR5 = false;
```

```
            TR6 = true;
```

```
        elseif poswaveform(kk-1) == -A(kk-1);
```

```
            poswaveform(kk) = -A(kk);
```

```
        elseif poswaveform(kk-1) == 0;
```



```
    poswaveform(kk) = 0;
end
```

```
% switching to T6 (-B voltage)
```

```
elseif TR6 == true;
```

```
    if T6(kk) <= .0005 && T6(kk) < T6(kk-1);
```

```
        poswaveform(kk) = -B(kk);
```

```
        TR6 = false;
```

```
        TR1 = true;
```

```
elseif poswaveform(kk-1) == C(kk-1);
```

```
    poswaveform(kk) = C(kk);
```

```
elseif poswaveform(kk-1) == 0;
```

```
    poswaveform(kk) = 0;
```

```
end
```

```
% switching to T1 (A voltage)
```

```
elseif TR1 == true;
```

```
    if T1(kk) <= 0.0005 && T1(kk) < T1(kk-1);
```

```
        poswaveform(kk)=A(kk);
```

```
        TR1 = false;
```

```
        TR2 = true;
```

```
elseif poswaveform(kk-1) == -B(kk-1);
```

```
    poswaveform(kk) = -B(kk);
```

```
elseif poswaveform (kk-1) == 0;
```

```
    poswaveform(kk) = 0;
end
```

```
% switching to T2 (-C voltage)
```

```
elseif TR2 == true;
```

```
    if T2(kk) <= 0.0005 && T2(kk) < T2(kk-1);
```

```
        poswaveform(kk) = -C(kk);
```

```
        TR2 = false;
```

```
        TR3 = true;
```

```
elseif poswaveform(kk-1) == A(kk-1);
```

```
    poswaveform(kk) = A(kk);
```

```
elseif poswaveform (kk-1) == 0;
```

```
    poswaveform(kk) = 0;
```

```
end
```

```
% switching to T3 (B voltage)
```

```
elseif TR3 == true;
```

```
    if T3(kk) <= 0.0005 && T3(kk) < T3(kk-1);
```

```
        poswaveform(kk) = B(kk);
```

```
        TR3 = false;
```

```
        TR4 = true;
```

```
elseif poswaveform(kk-1) == -C(kk-1);
```

```
    poswaveform(kk) = -C(kk);
```

```
elseif poswaveform (kk-1) == 0;
```

```

        poswaveform(kk) = 0;
    end

% switching to T4 (-A voltage)
elseif TR4 == true;
    if T4(kk) <= 0.0005 && T4(kk) < T4(kk-1);
        poswaveform(kk) = -A(kk);
        TR4 = false;
        TR5 = true;
    elseif poswaveform(kk-1) == B(kk-1);
        poswaveform(kk) = B(kk);
    elseif poswaveform(kk-1) == 0;
        poswaveform(kk) = 0;
    end
end

end

% Negative converter steps
% first step
if kk == 1
    negwaveform(kk) = A(kk);
    TN2 = true;

% switching to T2 (-C voltage)
elseif TN2 == true;

```

```

if T2(kk) >= -0.0005 && T2(kk) > T2(kk-1);
    negwaveform(kk) = -C(kk);
    TN2 = false;
    TN3 = true;
elseif negwaveform(kk-1) == A(kk-1);
    negwaveform(kk) = A(kk);
elseif negwaveform (kk-1) == 0;
    negwaveform(kk) = 0;
end

```

% switching to T3 (B voltage)

```

elseif TN3 == true;
    if T3(kk) >= -0.0005 && T3(kk) > T3(kk-1);
        negwaveform(kk) = B(kk);
        TN3 = false;
        TN4 = true;
    elseif negwaveform(kk-1) == -C(kk-1);
        negwaveform(kk) = -C(kk);
    elseif negwaveform (kk-1) == 0;
        negwaveform(kk) = 0;
    end

```

% switching to T4 (-A voltage)

```

elseif TN4 == true;

```

```

if T4(kk) >= -0.0005 && T4(kk) > T4(kk-1);
    negwaveform(kk) = -A(kk);
    TN4 = false;
    TN5 = true;
elseif negwaveform(kk-1) == B(kk-1);
    negwaveform(kk) = B(kk);
elseif negwaveform(kk-1) == 0;
    negwaveform(kk) = 0;
end

```

% switching to T5 (C voltage)

```

elseif TN5 == true;
    if T5(kk) >= -0.0005 && T5(kk) > T5(kk-1);
        negwaveform(kk) = C(kk);
        TN5 = false;
        TN6 = true;
    elseif negwaveform(kk-1) == -A(kk-1);
        negwaveform(kk) = -A(kk);
    elseif negwaveform(kk-1) == 0;
        negwaveform(kk) = 0;
    end

```

% switching to T6 (-B voltage)

```

elseif TN6 == true;

```

```

if T6(kk) >= -0.0005 && T6(kk) > T6(kk-1);
    negwaveform(kk) = -B(kk);
    TN6 = false;
    TN1 = true;
elseif negwaveform(kk-1) == C(kk-1);
    negwaveform(kk) = C(kk);
elseif negwaveform(kk-1) == 0;
    negwaveform(kk) = 0;
end

% switching to T1 (A voltage)
elseif TN1 == true;
    if T1(kk) >= -0.0005 && T1(kk) > T1(kk-1);
        negwaveform(kk)=A(kk);
        TN1 = false;
        TN2 = true;
    elseif negwaveform(kk-1) == -B(kk-1);
        negwaveform(kk) = -B(kk);
    elseif negwaveform(kk-1) == 0;
        negwaveform(kk) = 0;
    end
end
end
end

```

```

% figure (4);

% plot(t,poswaveform);

% axis([0 10/tf -1 1]);

%

% figure (5);

% plot(t,negwaveform);

% axis([0 10/tf -1 1]);

out = (poswaveform+negwaveform)/2;

% figure (6);

% plot(t,out);

% axis([0 10/tf -1 1]);

% transformP = fft(poswaveform)/((stop-start)/timestep);
% transformN = fft(negwaveform)/((stop-start)/timestep);
transform = abs((fft(out)/((stop-start)/timestep)));

Vharm = [];
lharm = [];
Z_ld = [];
mm = 1;

for ll = 1:1:(steps-1)/2+1

```

```

if ll == tf*5+1
    Vfund(1) = transform(ll);
    Vfund(2) = (ll-1)/5;
    Z_ld_fund = sqrt(R^2+(2*pi*L*tf)^2);
    Ifund(1) = Vfund(1)/Z_ld_fund;
    Ifund(2) = Vfund(2);
else
    if transform(ll) >= 10^-(45/20) && (ll-1)/5 == floor((ll-1)/5)
        Z_ld(mm) = sqrt(R^2+(2*pi*L*(ll-1))^2);
        Vharm(mm,1) = transform(ll);
        Vharm(mm,2) = (ll-1)/5;
        Iharm(mm,1) = Vharm(mm,1)/Z_ld(mm);
        Iharm(mm,2) = Vharm(mm,2);
        mm = mm+1;
    end
end
end

THarm = sqrt(sum(Iharm(:,1).^2));
THD = 100*THarm/Ifund(1);

THDarray(ii,1) = THD;
THDarray(ii,2) = f/tf;
ii = ii+1;

```



```

end

THDarray

%Output harmonic spectrum -- Displayed in test file

% Z = [];

% for oo = 1:steps

%   Z(oo) = sqrt(R^2+(2*pi*(oo-1)/5*L)^2);

% end

% current = transform./Z;

% current = 20*log10((current)/max(current));

% transform = 20*log10((transform)/max(transform));

%

% figure (7);

% fg=1/timestep*(0:(steps-1)/2)/((stop-start)/timestep);

% plot(fg,transform(1:25001));

% axis([0 5000 -100 0]);

%

% figure (8);

% plot(fg,current(1:25001));

% axis([0 5000 -100 0]);

figure (9);

```

```
plot(THDarray(:,2),THDarray(:,1));
```

THIS PAGE INTENTIONALLY LEFT BLANK

APPENDIX C. MATLAB INPUT CURRENT TOTAL HARMONIC DISTORTION TEST PROGRAM

```
%Jonathan Gilliom  
  
%Thesis THD Solving script  
  
%Last Revised 31 MAY 06  
  
  
clear all  
  
format compact  
  
format short  
  
  
%information about input waveforms  
  
timestep = .0001;  
  
stop = 5;  
  
start = 0;  
  
steps = (stop-start)/timestep+1;  
  
tf = 14;  
  
t = [start:timestep:stop];  
  
ref = .99*sin(2*pi*tf*t);  
  
ii = 1;  
  
  
%Load of Cycloconverter  
  
R = 4;  
  
L = .00;  
  
imp = L*2*pi*tf;
```

```

theta = atan(imp/R); %use atan -- assume R is positive
PF = cos(theta)

for jj = 20:4:144

%reference voltage for cycloconverter control

f = jj;

A = sin(2*pi*f*t);
B = sin(2*pi*f*t-2*pi/3);
C = sin(2*pi*f*t+2*pi/3);

%triggering waveforms, normalized to 1
Trigger1 = sin(2*pi*f*t+pi/6);
Trigger2 = -sin(2*pi*f*t+5*pi/6);
Trigger3 = sin(2*pi*f*t-pi/2);
Trigger4 = -sin(2*pi*f*t+pi/6);
Trigger5 = sin(2*pi*f*t+5*pi/6);
Trigger6 = -sin(2*pi*f*t-pi/2);

%Graphical representation of input signals, displayed on test file

% figure (1);

% plot(t,A,'r');

% hold on;

% plot(t,-C,'c');

```

```
% plot(t,B,'blue');  
% plot(t,-A,'k');  
% plot(t,C,'green');  
% plot(t,-B,'m');  
% hold off;  
%  
% figure (2);  
% plot(t,Trigger1,'r');  
% hold on;  
% plot(t,Trigger2,'c');  
% plot(t,Trigger3,'blue');  
% plot(t,Trigger4,'k');  
% plot(t,Trigger5,'green');  
% plot(t,Trigger6,'m');  
% plot(t,ref,'p');  
% hold off;  
%  
% figure (3);  
% plot(t,T1,'r');  
% hold on;  
% plot(t,T2,'c');  
% plot(t,T3,'blue');  
% plot(t,T4,'k');  
% plot(t,T5,'green');
```

```

% plot(t,T6,'m');

% plot(t,0);

% hold off;

% Trigger states, these show which SCR's are currently on, also set initial
% conditions. Assume the converter starts at positive Converter input of
% -A and a negative converter input of A. This starts output at a sin wave

for ij = 1:1:3

TR = [0 0 0 0 1 0];
TN = [0 1 0 0 0 0];

ref = circshift(ref,[0,round(((1/tf)/timestep)/3)]);

T1 = Trigger1-ref;
T2 = Trigger2-ref;
T3 = Trigger3-ref;
T4 = Trigger4-ref;
T5 = Trigger5-ref;
T6 = Trigger6-ref;

posA = [];
negA = [];
poswaveform = [];

```

```

negwaveform = [];

for kk = 1:steps

    % Positive converter steps

    % switching to T5 (C voltage)
    if TR(5) == true;
        if kk >= 2 && T5(kk) <= .0005 && T5(kk) < T5(kk-1);
            poswaveform(kk) = C(kk);
            %posC(kk) = C(kk);
            posA(kk) = -C(kk);
            TR(5) = false;
            TR(6) = true;
        elseif kk == 1 || poswaveform(kk-1) == -A(kk-1);
            poswaveform(kk) = -A(kk);
            posA(kk) = A(kk);
            %posB(kk) = -A(kk)
        elseif poswaveform(kk-1) == 0;
            poswaveform(kk) = 0;
        end

    % switching to T6 (-B voltage)
    elseif TR(6) == true;

```



```

if kk >= 2 && T6(kk) <= .0005 && T6(kk) < T6(kk-1);
    poswaveform(kk) = -B(kk);
    %posB(kk) = -B(kk);
    %posC(kk) = B(kk);
    TR(6) = false;
    TR(1) = true;
elseif kk == 1 || poswaveform(kk-1) == C(kk-1);
    poswaveform(kk) = C(kk);
    %posC(kk) = C(kk);
    posA(kk) = -C(kk);
elseif poswaveform(kk-1) == 0;
    poswaveform(kk) = 0;
end

```

% switching to T1 (A voltage)

```

elseif TR(1) == true
    if kk >= 2 && T1(kk) <= 0.0005 && T1(kk) < T1(kk-1);
        poswaveform(kk) = A(kk);
        posA(kk) = A(kk);
        %posB(kk) = -A(kk);
        TR(1) = false;
        TR(2) = true;
    elseif kk == 1 || poswaveform(kk-1) == -B(kk-1);
        poswaveform(kk) = -B(kk);
    end

```

```

    %posB(kk) = -B(kk);

    %posC(kk) = B(kk);

elseif poswaveform (kk-1) == 0;

    poswaveform(kk) = 0;

end

% switching to T2 (-C voltage)

elseif TR(2) == true;

    if kk >= 2 && T2(kk) <= 0.0005 && T2(kk) < T2(kk-1);

        poswaveform(kk) = -C(kk);

        %posC(kk) = C(kk);

        posA(kk) = -C(kk);

        TR(2) = false;

        TR(3) = true;

    elseif kk == 1 || poswaveform(kk-1) == A(kk-1);

        poswaveform(kk) = A(kk);

        posA(kk) = A(kk);

        %posB(kk) = -A(kk);

    elseif poswaveform (kk-1) == 0;

        poswaveform(kk) = 0;

    end

% switching to T3 (B voltage)

elseif TR(3) == true;

```

```

if kk >= 2 && T3(kk) <= 0.0005 && T3(kk) < T3(kk-1);
    poswaveform(kk) = B(kk);
    %posB(kk) = B(kk);
    %posC(kk) = -B(kk);
    TR(3) = false;
    TR(4) = true;
elseif kk == 1 || poswaveform(kk-1) == -C(kk-1);
    poswaveform(kk) = -C(kk);
    %posC(kk) = C(kk);
    posA(kk) = -C(kk);
elseif poswaveform(kk-1) == 0;
    poswaveform(kk) = 0;
end

```

% switching to T4 (-A voltage)

```

elseif TR(4) == true;
    if kk >= 2 && T4(kk) <= 0.0005 && T4(kk) < T4(kk-1);
        poswaveform(kk) = -A(kk);
        posA(kk) = A(kk);
        %posB(kk) = -A(kk);
        TR(4) = false;
        TR(5) = true;
    elseif kk == 1 || poswaveform(kk-1) == B(kk-1);
        poswaveform(kk) = B(kk);
    end

```

```

    %posB(kk) = B(kk);
    %posC(kk) = -B(kk);
elseif poswaveform (kk-1) == 0;
    poswaveform(kk) = 0;
end
end

% Negative converter steps

% switching to T2 (-C voltage)
if TN(2) == true;
    if kk >= 2 && T2(kk) >= -0.0005 && T2(kk) > T2(kk-1);
        negwaveform(kk) = -C(kk);
        %negC(kk) = C(kk);
        negA(kk) = -C(kk);
        TN(2) = false;
        TN(3) = true;
    elseif kk == 1 || negwaveform(kk-1) == A(kk-1);
        negwaveform(kk) = A(kk);
        negA(kk) = A(kk);
        %negB(kk) = -A(kk);
    elseif negwaveform (kk-1) == 0;
        negwaveform(kk) = 0;
    end
end

```

```

% switching to T3 (B voltage)
elseif TN(3) == true;
    if kk >= 2 && T3(kk) >= -0.0005 && T3(kk) > T3(kk-1);
        negwaveform(kk) = B(kk);
        %negB(kk) = B(kk);
        %negC(kk) = -B(kk);
        TN(3) = false;
        TN(4) = true;
    elseif kk == 1 || negwaveform(kk-1) == -C(kk-1);
        negwaveform(kk) = -C(kk);
        %negC(kk) = C(kk);
        negA(kk) = -C(kk);
    elseif negwaveform(kk-1) == 0;
        negwaveform(kk) = 0;
    end

```

```

% switching to T4 (-A voltage)
elseif TN(4) == true;
    if kk >= 2 && T4(kk) >= -0.0005 && T4(kk) > T4(kk-1);
        negwaveform(kk) = -A(kk);
        %negB(kk) = -A(kk);
        negA(kk) = A(kk);
        TN(4) = false;
    end

```

```

    TN(5) = true;
elseif kk == 1 || negwaveform(kk-1) == B(kk-1);
    negwaveform(kk) = B(kk);
    %negB(kk) = B(kk);
    %negC(kk) = -B(kk);
elseif negwaveform (kk-1) == 0;
    negwaveform(kk) = 0;
end

% switching to T5 (C voltage)
elseif TN(5) == true;
    if kk >= 2 && T5(kk) >= -0.0005 && T5(kk) > T5(kk-1);
        negwaveform(kk) = C(kk);
        %negC(kk) = C(kk);
        negA(kk) = -C(kk);
        TN(5) = false;
        TN(6) = true;
    elseif kk == 1 || negwaveform(kk-1) == -A(kk-1);
        negwaveform(kk) = -A(kk);
        negA(kk) = A(kk);
        %negB(kk) = -A(kk);
    elseif negwaveform(kk-1) == 0;
        negwaveform(kk) = 0;
    end
end

```

```

% switching to T6 (-B voltage)
elseif TN(6) == true;
    if kk >= 2 && T6(kk) >= -0.0005 && T6(kk) > T6(kk-1);
        negwaveform(kk) = -B(kk);
        %negB(kk) = -B(kk);
        %negC(kk) = B(kk);
        TN(6) = false;
        TN(1) = true;
    elseif kk == 1 || negwaveform(kk-1) == C(kk-1);
        negwaveform(kk) = C(kk);
        %negC(kk) = C(kk);
        negA(kk) = -C(kk);
    elseif negwaveform(kk-1) == 0;
        negwaveform(kk) = 0;
    end

```

```

% switching to T1 (A voltage)
elseif TN(1) == true;
    if kk >= 2 && T1(kk) >= -0.0005 && T1(kk) > T1(kk-1);
        negwaveform(kk) = A(kk);
        negA(kk) = A(kk);
        %negB(kk) = -A(kk);
        TN(1) = false;
    end

```

```

        TN(2) = true;
    elseif kk == 1 || negwaveform(kk-1) == -B(kk-1);
        negwaveform(kk) = -B(kk);
        %negB(kk) = -B(kk);
        %negC(kk) = B(kk);
    elseif negwaveform (kk-1) == 0;
        negwaveform(kk) = 0;
    end
end
end

if numel(posA) < kk
    posA(kk) = 0;
end

if numel(negA) < kk
    negA(kk) = 0;
end

% figure (4);
% plot(t,poswaveform);
% axis([0 10/tf -1 1]);
%
% figure (5);
% plot(t,negwaveform);

```



```

% axis([0 10/tf -1 1]);

%out = (poswaveform+negwaveform)/2;

outA = posA;

% figure;

% plot(t,poswaveform);

% axis([0 1/14 -1 1]);

inputs(ij,:) = outA;

end

input = sum(inputs);

% figure (10);

% plot(t,input);

% axis([0 1/tf -2 2]);

%

% figure (6);

% plot(t,outA);

% axis([0 1/tf -1 1]);

% transformP = fft(poswaveform)/((stop-start)/timestep);

% transformN = fft(negwaveform)/((stop-start)/timestep);

transform = abs((fft(input)/((stop-start)/timestep)));

```

```

Vharm = [];
lharm = [];
Z_ld = [];
mm = 1;

for ll = 1:1:(steps-1)/2+1
    if ll == 5*f+1
        Vfund(1) = transform(ll);
        Vfund(2) = (ll-1)/5;
        Z_ld_fund = sqrt(R^2+(2*pi*L*tf)^2);
        Ifund(1) = Vfund(1)/Z_ld_fund;
        Ifund(2) = Vfund(2);
    else
        if transform(ll) >= 10^-(45/20) && (ll-1)/5 == floor((ll-1)/5)
            Z_ld(mm) = sqrt(R^2+(2*pi*L*(ll-1))^2);
            Vharm(mm,1) = transform(ll);
            Vharm(mm,2) = (ll-1)/5;
            lharm(mm,1) = Vharm(mm,1)/Z_ld(mm);
            lharm(mm,2) = Vharm(mm,2);
            mm = mm+1;
        end
    end
end
end

```

```

THarm = sqrt(sum(Iharm(:,1).^2));
THD = 100*THarm/Ifund(1);

THDarray(ii,1) = THD;
THDarray(ii,2) = f/ff;
ii = ii+1;
end
THDarray

%Output harmonic spectrum -- Displayed in test file

% Z = [];
% for oo = 1:steps
%   Z(oo) = sqrt(R^2+(2*pi*(oo-1)/5*L)^2);
% end

% current = transform./Z;
% current = 20*log10((current)/max(current));
transform = 20*log10((transform)/max(transform));
%
figure (7);
fg=1/timestep*(0:(steps-1)/2)/((stop-start)/timestep);
plot(fg,transform(1:25001));

```

```
axis([0 5000 -100 0]);  
  
%  
  
% figure (8);  
  
% plot(fg,current(1:25001));  
  
% axis([0 5000 -100 0]);  
  
  
figure (9);  
  
plot(THDarray(:,2),THDarray(:,1));
```

THIS PAGE INTENTIONALLY LEFT BLANK

LIST OF REFERENCES

- [1] I. Batarseh, Power Electronic Circuits, New York: Wiley, 2004.
- [2] R. Ashton lecture notes, Chapter 1 – Introduction.
- [3] Z. Wang and Y. Liu, “Modeling and Simulation of a Cycloconverter Drive System for Harmonic Studies”, IEEE Transactions on Modern Electronics, vol. 47, no. 3, June 2000, pp. 533-541.
- [4] L. Juby, R Bucknall, and N. A. Harris, “A Harmonics Reduction Technique for Cycloconverter Propulsion Drives,” in Electrical Machines and Drives, No. 412, September 1995, pp. 333-337.
- [5] E. Gunther, “Interharmonics in Power Systems,” in Power Engineering Society Summer Meeting, 2001. IEEE, vol. 2, July 2001, pp. 813-817.
- [6] P. Syam, G. Bandyopadhyay, P. Nandi, and A. Chattopadhyay, “Simulation and Experimental Study of Interharmonic Performance of a Cycloconverter-Fed Synchronous Motor Drive,” IEEE Transactions on Energy Conversion, vol. 19, no. 2, June 2004, pp. 325-332.
- [7] P. Syam, P. Nandi, and A. Chattopadhyay, “Improvement in Power Quality and a Simple Method of Subharmonic Suppression for a Cycloconverter-Fed Synchronous Motor Drive,” Electronic Power Applications, IEEE Proceedings-, vol. 149, issue 4, July 2002, pp. 292-303.
- [8] Y. Liu, G. Heydt, and R. Chu, “Power Quality Impact of Cycloconverter Control Strategies,” IEEE Transactions on Power Delivery, vol. 20, no. 2, April 2005, pp. 1711-1718.
- [9] P. Syam, P. Nandi, and A. Chattopadhyay, “Effect of Output Current Ripple on the Input Supply Current and Power Quality for a Cycloconverter-Fed Drive,” Electronic Power Applications, IEEE Proceedings-, vol. 151, issue 4, July 2004, pp. 425-433.

- [10] C. Mercer, The Analysis, Simulation and Control of Cycloconverter Drives for Ship Propulsion, Naval Postgraduate School, 1996.
- [11] L. Wilkerson, "CGC Healy's IPP (Integrated Power Plant)," presented at NRAC conference, July 2001.
- [12] A. Al-Hinai and A. Feliachi, "Dynamic Model of a Microturbine used as a Distributed Generator," in System Theory, 2002. Proceedings on the Thirty-Fourth Symposium on, March 2002, pp. 209-213.
- [13] B Ozpineci and L. Tolbert, "Cycloconverters."
- [14] R. Ashton lecture notes, Chapter 8 – Inverters.
- [15] K. Smith and L Ran, "Input Current Harmonics Analysis of Pseudo 12-Pulse 3-Phase to 6-Phase Cycloconverters," IEEE Transactions on Power Electronics, vol. 11, no. 4, July 1996, pp. 629-640.
- [16] R. Ashton lecture notes, Chapter 5 – Phase Controlled Rectifiers.

INITIAL DISTRIBUTION LIST

1. Defense Technical Information Center
Ft. Belvoir, Virginia
2. Dudley Knox Library
Naval Postgraduate School
Monterey, California
3. Naval Surface Warfare Center Carderock Division
Code 984
Attn: Tom Fiske
Philadelphia, Pennsylvania
4. Office of Naval Research
Code 334, Room 669
Attn: Terry Ericksen
Arlington, Virginia
5. Dr. Jeffry Knorr, Chairman, Department of Electrical and Computer Engineering
Code EC/Ko
Naval Postgraduate School
Monterey, California
6. Dr. Robert W. Ashton, Department of Electrical and Computer Engineering
Code EC/Ko
Naval Postgraduate School
Monterey, California