



## Calhoun: The NPS Institutional Archive

---

Theses and Dissertations

Thesis Collection

---

2006-06

# Intelligent Maintenance Aid (IMA)

Shockley, Keith J.

Monterey, California. Naval Postgraduate School

---

<http://hdl.handle.net/10945/2719>



Calhoun is a project of the Dudley Knox Library at NPS, furthering the precepts and goals of open government and government transparency. All information contained herein has been approved for release by the NPS Public Affairs Officer.

**Dudley Knox Library / Naval Postgraduate School**  
**411 Dyer Road / 1 University Circle**  
**Monterey, California USA 93943**

<http://www.nps.edu/library>



**NAVAL  
POSTGRADUATE  
SCHOOL**

**MONTEREY, CALIFORNIA**

**THESIS**

**INTELLIGENT MAINTENANCE AID (IMA)**

by

Keith J. Shockley

June 2006

Thesis Advisor:  
Co-Advisor:

Man-Tak Shing  
Michael Smith

**Approved for public release; distribution is unlimited**

**THIS PAGE INTENTIONALLY LEFT BLANK**

REPORT DOCUMENTATION PAGE			Form Approved OMB No. 0704-0188	
Public reporting burden for this collection of information is estimated to average 1 hour per response, including the time for reviewing instruction, searching existing data sources, gathering and maintaining the data needed, and completing and reviewing the collection of information. Send comments regarding this burden estimate or any other aspect of this collection of information, including suggestions for reducing this burden, to Washington headquarters Services, Directorate for Information Operations and Reports, 1215 Jefferson Davis Highway, Suite 1204, Arlington, VA 22202-4302, and to the Office of Management and Budget, Paperwork Reduction Project (0704-0188) Washington DC 20503.				
1. AGENCY USE ONLY (Leave blank)		2. REPORT DATE June 2006	3. REPORT TYPE AND DATES COVERED Master's Thesis	
4. TITLE AND SUBTITLE: Intelligent Maintenance Aid (IMA)			5. FUNDING NUMBERS	
6. AUTHOR(S) Keith J. Shockley				
7. PERFORMING ORGANIZATION NAME(S) AND ADDRESS(ES) Naval Postgraduate School Monterey, CA 93943-5000			8. PERFORMING ORGANIZATION REPORT NUMBER	
9. SPONSORING /MONITORING AGENCY NAME(S) AND ADDRESS(ES) N/A			10. SPONSORING/MONITORING AGENCY REPORT NUMBER	
11. SUPPLEMENTARY NOTES The views expressed in this thesis are those of the author and do not reflect the official policy or position of the Department of Defense or the U.S. Government.				
12a. DISTRIBUTION / AVAILABILITY STATEMENT Approved for public release; distribution is unlimited			12b. DISTRIBUTION CODE	
<p><b>13. ABSTRACT (maximum 200 words)</b></p> <p>Technological complexities of current ground combat systems require advanced maintenance methods to keep the fleet in a state of operational readiness. Currently, maintenance personnel use paper Technical Manuals (TM) that are cumbersome and not easily transportable or updated in the field. This thesis proposes using the latest technology to support maintainers in the field or depot by integrating the TMs with the onboard diagnostics Built-In-Test (BIT) and Fault Isolation Test (FIT) of the vehicle, to provide the maintainer with an improved diagnostics tool to expedite troubleshooting analysis.</p> <p>This will be accomplished by connecting the vehicle, using the vehicle's 1553 multiplex bus, with the Graphical User Interface (GUI) of an Intelligent Maintenance Aid (IMA). The IMA will use Troubleshooting Procedure (TP) codes generated during BIT and FIT testing. Using the information provided by these TP codes, through the IMA GUI, information from the technical manuals will be displayed to aid the maintainers in their diagnostic work.</p> <p>The results of this thesis will serve as a baseline for further research and will be presented to the program management office for combat systems (PM-CS) for further consideration and development.</p>				
14. SUBJECT TERMS Built In Test (BIT), Fault Isolation Test (FIT), maintenance, vehicle electronics, 1553 multiplex bus			15. NUMBER OF PAGES 83	
			16. PRICE CODE	
17. SECURITY CLASSIFICATION OF REPORT Unclassified	18. SECURITY CLASSIFICATION Unclassified	19. SECURITY CLASSIFICATION OF ABSTRACT Unclassified	20. LIMITATION OF ABSTRACT UL	

THIS PAGE INTENTIONALLY LEFT BLANK

**Approved for public release; distribution is unlimited**

**INTELLIGENT MAINTENANCE AID (IMA)**

Keith J. Shockley  
Civilian, United States Army RDECOM-TACOM  
B.S.E.E., Lawrence Institute of Technology, 1988

Submitted in partial fulfillment of the  
requirements for the degree of

**MASTER OF SCIENCE IN SOFTWARE ENGINEERING**

from the

**NAVAL POSTGRADUATE SCHOOL**  
**June 2006**

Author: Keith J. Shockley

Approved by: Man-Tak Shing  
Thesis Advisor

Michael Smith  
Co-Advisor

Peter Denning  
Chairman, Computer Science Department

THIS PAGE INTENTIONALLY LEFT BLANK

## **ABSTRACT**

Technological complexities of current ground combat systems require advanced maintenance methods to keep the fleet in a state of operational readiness. Currently, maintenance personnel use paper Technical Manuals (TM) that are cumbersome and not easily transportable or updated in the field. This thesis proposes using the latest technology to support maintainers in the field or depot by integrating the TMs with the onboard diagnostics Built-In-Test (BIT) and Fault Isolation Test (FIT) of the vehicle, to provide the maintainer with an improved diagnostics tool to expedite troubleshooting analysis.

This will be accomplished by connecting the vehicle, using the vehicle's 1553 multiplex bus, with the Graphical User Interface (GUI) of an Intelligent Maintenance Aid (IMA). The IMA will use Troubleshooting Procedure (TP) codes generated during BIT and FIT testing. Using the information provided by these TP codes, through the IMA GUI, information from the technical manuals will be displayed to aid the maintainers in their diagnostic work.

The results of this thesis will serve as a baseline for further research and will be presented to the program management office for combat systems (PM-CS) for further consideration and development.



THIS PAGE INTENTIONALLY LEFT BLANK

# TABLE OF CONTENTS

<b>I.</b>	<b>INTRODUCTION.....</b>	<b>1</b>
<b>A.</b>	<b>BACKGROUND INFORMATION .....</b>	<b>1</b>
<b>B.</b>	<b>STATEMENT OF PROBLEM.....</b>	<b>2</b>
<b>C.</b>	<b>PROPOSED SOLUTION.....</b>	<b>3</b>
<b>D.</b>	<b>THESIS ORGANIZATION.....</b>	<b>5</b>
<b>II.</b>	<b>ABRAMS MAIN BATTLE TANK (AN OVERVIEW) .....</b>	<b>7</b>
<b>A.</b>	<b>M1A2 SYSTEM ARCHITECTURE.....</b>	<b>7</b>
<b>B.</b>	<b>M1A2 HARDWARE ARCHITECTURE .....</b>	<b>8</b>
<b>C.</b>	<b>M1A2 SOFTWARE ARCHITECTURE .....</b>	<b>9</b>
<b>D.</b>	<b>MIL-STD-1553 DIGITAL TIME DIVISON COMMAND/RESPONSE MULTIPLEX DATA BUS.....</b>	<b>10</b>
	<b>1. Hardware Description .....</b>	<b>10</b>
	<b>2. Protocol Description .....</b>	<b>11</b>
	<b>3. 1553 Data Bus Message Content.....</b>	<b>11</b>
	<b>4. 1553 Data Bus Command Word.....</b>	<b>12</b>
	<b>5. 1553 Data Bus Status Word .....</b>	<b>12</b>
	<b>6. 1553 Data Bus Data Word with Status Word .....</b>	<b>13</b>
	<b>7. 1553 Data Bus Message Transfer .....</b>	<b>14</b>
	<b>8. 1553 Data Bus BC to RT Sequence .....</b>	<b>14</b>
	<b>9. 1553 Data Bus RT to BC Sequence .....</b>	<b>15</b>
	<b>10. 1553 Data Bus RT to RT Sequence .....</b>	<b>15</b>
<b>III.</b>	<b>REQUIREMENTS AND SPECIFICATION .....</b>	<b>17</b>
<b>A.</b>	<b>REQUIREMENTS FOR IMA .....</b>	<b>17</b>
	<b>1. System Goals.....</b>	<b>18</b>
	<b>2. Assumptions and Dependencies.....</b>	<b>18</b>
	<b>3. Requirements/Function Assumptions .....</b>	<b>18</b>
<b>B.</b>	<b>SYSTEM FUNCTIONS.....</b>	<b>19</b>
	<b>1. Required States and Modes.....</b>	<b>19</b>
	<b>2. System Capability Requirements .....</b>	<b>19</b>
<b>C.</b>	<b>USE CASE DIAGRAM .....</b>	<b>21</b>
<b>D.</b>	<b>USE CASE SCENARIOS.....</b>	<b>22</b>
	<b>1. Use Case 1: Log In .....</b>	<b>22</b>
	<b>2. Use Case 2: Run Test .....</b>	<b>23</b>
<b>E.</b>	<b>SYSTEM CONTEXT DIAGRAM .....</b>	<b>24</b>
<b>F.</b>	<b>CONCEPTUAL DIAGRAM.....</b>	<b>26</b>
<b>G.</b>	<b>SYSTEM SEQUENCE DIAGRAM .....</b>	<b>27</b>
<b>H.</b>	<b>GLOSSARY.....</b>	<b>28</b>
<b>IV.</b>	<b>SOFTWARE ARCHITECTURE DESIGN.....</b>	<b>29</b>
<b>A.</b>	<b>INTRODUCTION FOR EMBEDDED DIAGNOSTICS FOR M1A2 TANK.....</b>	<b>29</b>
	<b>1. Self Test (ST) .....</b>	<b>30</b>

2.	Built-In-Test (BIT).....	32
3.	Fault Isolation Test (FIT).....	33
B.	IMA PROTOTYPE .....	34
C.	REAL-TIME FAULT REPORTING.....	34
D.	FAULT DATA.....	36
E.	GRAPHICAL FAULT CORRELATION .....	37
F.	FIT SECTION.....	39
G.	FIT DATA.....	39
H.	IMA FIT GRAPHICS.....	40
I.	GENERIC HTML CONVERSION.....	41
J.	PARSE PDF TEXT REFERENCES.....	42
V.	TEST AND EVALUATION.....	45
A.	TEST GOALS .....	45
B.	IMA TEST SETUP .....	46
1.	IMA BIT Capability .....	46
2.	IMA FIT Capability.....	47
3.	IMA TP Manual Hyperlinking.....	47
C.	TEST PROCEDURE .....	47
1.	IMA BIT Capability .....	47
2.	IMA FIT Capability.....	50
3.	IMA TP Manual Hypertext Linking.....	51
D.	TEST RESULTS/REPORTING.....	51
1.	IMA BIT Capability Test Results.....	52
2.	IMA FIT Capability Test Results.....	54
3.	IMA Hypertext Linking Test Results/Reporting .....	55
4.	Problem with System Buffer Reset.....	55
E.	TP MANUAL USAGE.....	60
VI.	CONCLUSION .....	61
A.	LESSONS LEARNED .....	61
B.	FOLLOW ON WORK .....	62
1.	Pre-Planned Product Improvement .....	62
2.	Removing the System Buffer Reset Problem.....	62
	LIST OF REFERENCES .....	63
	INITIAL DISTRIBUTION LIST .....	65

## LIST OF FIGURES

Figure 1.	SPORT PC.....	2
Figure 2.	IMA Screen Shot.....	4
Figure 3.	M1A2 System Diagram.....	7
Figure 4.	M1A2 Functional Software Diagram.....	10
Figure 5.	IMA Interfacing with the M1A2 tank.....	17
Figure 6.	High Level Use Case.....	21
Figure 7.	IMA System Context Diagram.....	24
Figure 8.	IMA Conceptual Diagram.....	26
Figure 9.	IMA System Sequence Diagram.....	27
Figure 10.	Operation and Status of Fault Management.....	29
Figure 11.	Data Packet Flow.....	32
Figure 12.	System Display Window.....	35
Figure 13.	CID Display Window.....	36
Figure 14.	Sub-address 30 Organization.....	37
Figure 15.	FIT Data Enumeration.....	40
Figure 16.	Conversion Process.....	41
Figure 17.	PDF Text Preference Location.....	42
Figure 18.	TP Code 333.....	43
Figure 19.	Hyperlink for TP333.....	44
Figure 20.	Injected BIT Faults For DID.....	48
Figure 21.	Injected BIT Faults For GCDP.....	49
Figure 22.	DECU BIT Fail on CID.....	50
Figure 23.	DID BIT Results on IMA.....	56
Figure 24.	DID BIT Sub-system Results on IMA.....	56
Figure 25.	DID BIT Reports from IMA.....	57
Figure 26.	GCDP BIT Results on IMA.....	57
Figure 27.	GCDP BIT Sub-system Results on IMA.....	58
Figure 28.	GCDP BIT Reports from IMA.....	58
Figure 29.	DECU FIT Results on CID.....	59
Figure 30.	DECU IMA FIT Results.....	59

THIS PAGE INTENTIONALLY LEFT BLANK

## LIST OF TABLES

Table 1.	Primary and Backup Systems .....	9
Table 2.	System Functions .....	20
Table 3.	System Attribute Table .....	21
Table 4.	External Events .....	25
Table 5.	Glossary of Terms.....	28
Table 6.	IMA Database Structure .....	38

THIS PAGE INTENTIONALLY LEFT BLANK

## ACRONYMS AND ABBREVIATIONS

BIT .....	Built-In Test
CID.....	Commander’s Integrated Display LRU
CSS .....	Combat Sustainment Support
DID .....	Driver’s Integrated Display LRU
DSESTS .....	Direct Support Electrical System Test Set
FCEU .....	Fire Control Electronic Unit LRU
FIT.....	Fault Isolation Test
GCDP .....	Gunner’s Control and Display Panel LRU
GDLS .....	General Dynamics Land Systems
HEU .....	Hull Electronic Unit LRU
HPDU.....	Hull Power Distribution Unit
H/TEU .....	Hull/Turret Electronic Unit LRU
IVIS.....	Inter-Vehicle Information System
LRU.....	Line Replaceable Unit
MTP .....	Manual Troubleshooting Procedure
NextGen .....	Next Generation Software Engineering Center
RIU.....	Radio Interface Unit LRU
RPC.....	Remote Power Control
SMI .....	Soldier-Machine Interface
SPORT .....	Soldier Portable On-Site Repair Tool
SRU.....	Shop Replaceable Unit
S/SDD .....	System/Segment Design Specification
ST .....	Self Tests
TP .....	Troubleshooting Procedure
TEU.....	Turret Electronic Unit LRU



THIS PAGE INTENTIONALLY LEFT BLANK

## **ACKNOWLEDGMENTS**

Special thanks to my fellow NPS students at the NextGen Software Engineering Center: Russ Menko, Juan Jones, and Karen LaFond, who continuously encouraged me to complete this thesis, and to Professor Man-Tak Shing at the Naval Postgraduate School, who gave me the confidence and inspiration to continue with the program.

To my Co-Advisor Mike Smith who suggested the idea for this thesis project many thanks.

I want to express my special appreciation to Art Chapman of DCS Corporation, without whose invaluable contribution the test and evaluation portion of this thesis would not have seen the light of day.

And last, but certainly the most important to me, special thanks for my wife, Flo, and my Associate Director Mag Athnasios.

THIS PAGE INTENTIONALLY LEFT BLANK

# I. INTRODUCTION

## A. BACKGROUND INFORMATION

As the Army improves the effectiveness of its forces with technology, the complexity of ground vehicle weapon systems continues to increase. These systems contain a multitude of Vetronics (Vehicle Electronics) and have become increasingly difficult to maintain and repair with traditional Army personnel, test equipment and technical documentation. Maintaining these systems requires highly trained personnel with in-depth knowledge of embedded systems. To meet the maintenance and repair demands of these systems, the Army must rely more on technology and less on humans. Future ground vehicle weapon systems must be designed to self-diagnose and provide test and maintenance interfaces to external test equipment. Integrated maintenance and repair capabilities with advanced technologies and Artificial Intelligence (AI) will improve the overall effectiveness of the force.

These solutions, however, do not address fielded vehicle systems. Presently, repairs are made, with the help of paper Technical Manuals (TM), at the depot level maintenance. When these systems were conceived it was not cost or technologically feasible to provide comprehensive embedded test and maintenance capabilities. Most systems were constrained to test connectors that provided limited test and diagnostic capability.

However, with the advent of the Personal Computer (PC), a powerful tool becomes available that can be leveraged for fielded Army systems even though it was not envisioned during development of these older systems. Most fielded ground vehicle systems contain standard data interfaces such as 1553, CAN, RS232 and Ethernet; the Army can exploit this and utilize the PC to extract data via these interfaces. Most systems with these types of interfaces provide some level of Built-In Test (BIT) and/or Fault Isolation Test (FIT) capability. The PC will be configured to monitor the above tests and provide status. With this captured information, the PC will analyze the diagnostic data and provide troubleshooting and repair information to maintenance personnel. The platform, called the Soldier Portable On-Site Repair Tool (SPORT),

primarily functions as a software downloader with no diagnostic/prognostic capability (Figure 1). The SPORT's inability to provide a portable capability (in addition to performing downloader duties) to perform diagnostic tasks severely hampers the maintenance operator's ability to keep their vehicles in constant state of mission readiness.

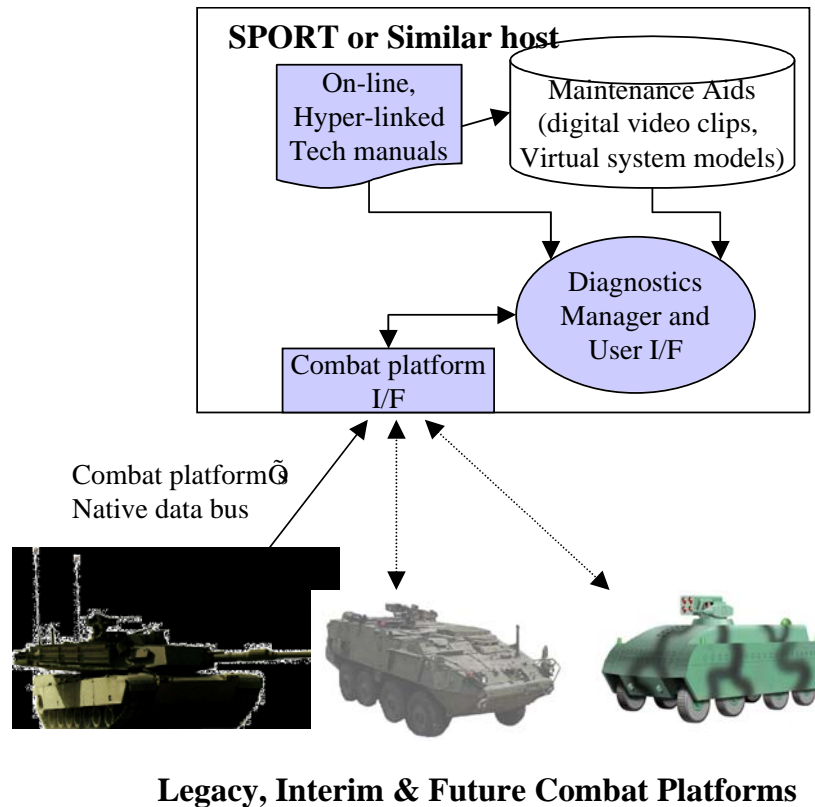

Figure 1. SPORT PC

**B. STATEMENT OF PROBLEM**

Currently, when performing on-board vehicle diagnostics, maintenance personnel rely on Technical Manuals (TM) to provide repair information. These TMs are usually available only to Depot repair facilities; this greatly reduces/impairs the ability to make repairs in the field, especially during combat battlefield conditions. For example, the M1A2 Main Battle Tank is an intelligent system containing multiple microprocessors, which have Built In Test (BIT) and Fault Isolation Test (FIT) capabilities. These tests report failures to the user interfaces on the Commander's Integrated Display (CID),

Driver's Integrated Display (DID), and Gunner's Control and Display Panel (GCDP). Failures are reported with Troubleshooting Procedure (TP) numbers that are cross-referenced with the TMs to isolate and repair the failed system components. The physical TMs are cumbersome to use and significantly add to the time required for diagnosing and repairing a vehicle system. The TMs also are updated on a scheduled basis with change notices and, if not updated regularly, can lead to misdiagnosis of the problem and provide faulty resolutions.

### **C. PROPOSED SOLUTION**

This thesis will investigate a portable intelligent solution for the problem stated above. Providing an Intelligent Maintenance Aid (IMA) that interfaces with ground vehicle weapon systems will satisfy most of the Army's maintenance requirements and will surpass current maintenance and diagnostic capabilities. This will be achieved by providing the user with an interface (I/F) to the system being evaluated (in our case, the M1A2 tank, but it could be any ground platform as the concept diagram below depicts). The native data bus will use one of the following standard protocols: 1553, CAN, RS232 and Ethernet to communicate to a SPORT or similar host. Once connected, the user will access IMA software to begin diagnosing the system under repair (see Figure 2 below).

Webbrowser-like interface

Automated Diagnostic data Acquisition, interpretation and Technical manual Lookup

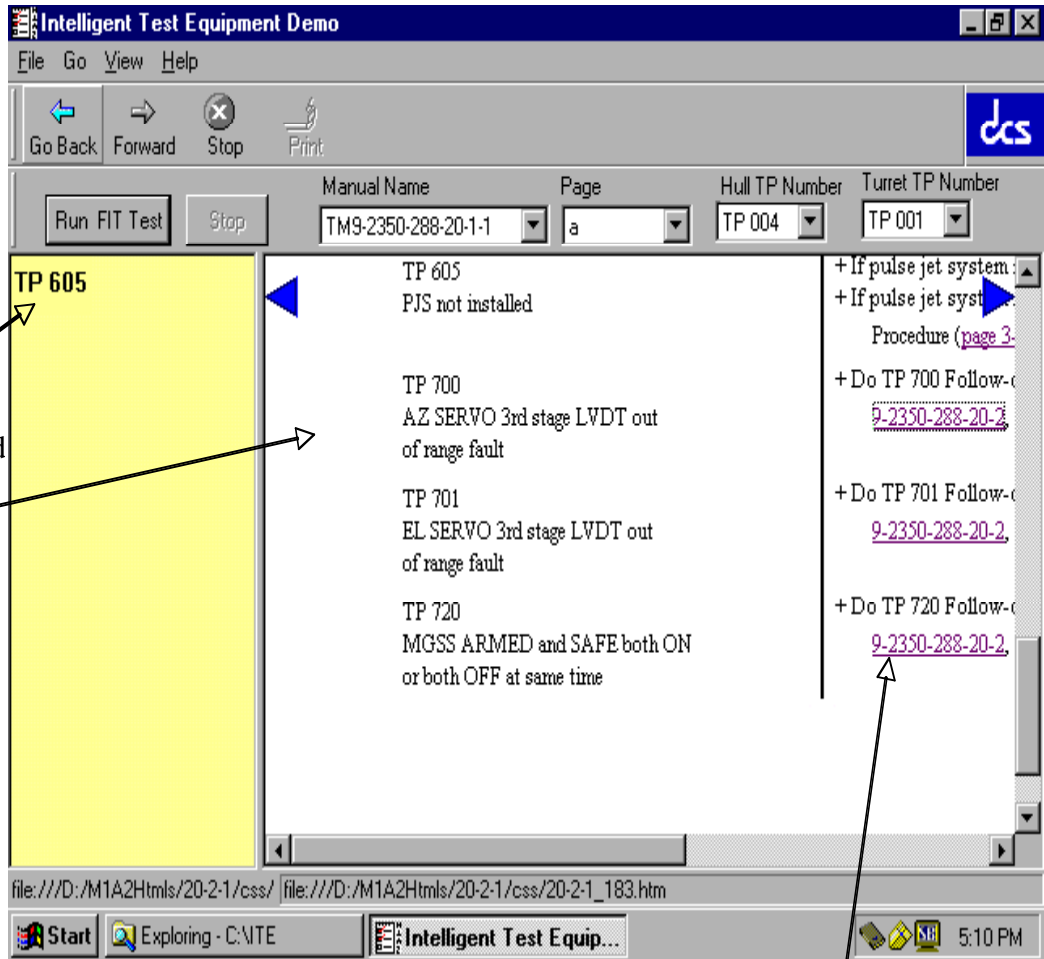

HTML 100% page links

Figure 2. IMA Screen Shot

The basic IMA system will automate the use of TMs. The approach will be to utilize the current TMs that have been captured electronically in Adobe Acrobat. The electronic TMs for the Hull and Turret will reside on the hard drive of the computer that hosts the IMA. We will develop algorithms to search the documents for the TP numbers that are reported by the M1A2 system.

## **D. THESIS ORGANIZATION**

This chapter gives a brief description of the problem addressed by the thesis and discusses a solution to this problem, using the IMA to aid maintenance personnel. It also provides a high level introduction into the on-board diagnostics of the M1A2 Main Battle tank.

Chapter II presents an overview of the M1A2 hardware and software architecture. It explains how the M1A2 tank system's computational components are connected via a MIL-STD-1553 data bus. The chapter also introduces a primer into the operational characteristics of the MIL-STD-1553 data bus.

Chapter III contains the requirements and design for the Intelligent Maintenance Aid (IMA). The design includes several elements of the Universal Modeling Language (UML): Use Case diagrams, System Context Diagram, and a Conceptual model.

Chapter IV consists of a detailed discussion of the proposed software architecture of the IMA project.

Chapter V contains the test and evaluation of the IMA project.

Chapter VI discusses the lessons learned and draws a conclusion.



THIS PAGE INTENTIONALLY LEFT BLANK

## II. ABRAMS MAIN BATTLE TANK (AN OVERVIEW)

### A. M1A2 SYSTEM ARCHITECTURE

The M1A2 tank system architecture provides for the interconnection of a series of distributed Line Replaceable Units (LRUs) via a power distribution and data distribution network. The M1A2 system architecture is based on a dual redundant data and utility bus design. The primary computational system components are interconnected via a Mil-Std 1553B Data Bus that provides digital communication between tank components. The utility bus is used for power management and provides the digital communication required to control power at various system components and loads. The hull and turret system components are separated via a slip ring that provides for a continual, uninterrupted, reliable connection for electrical circuits as well as air and hydraulics. The baseline M1A2 system architecture is depicted below in Figure 3.

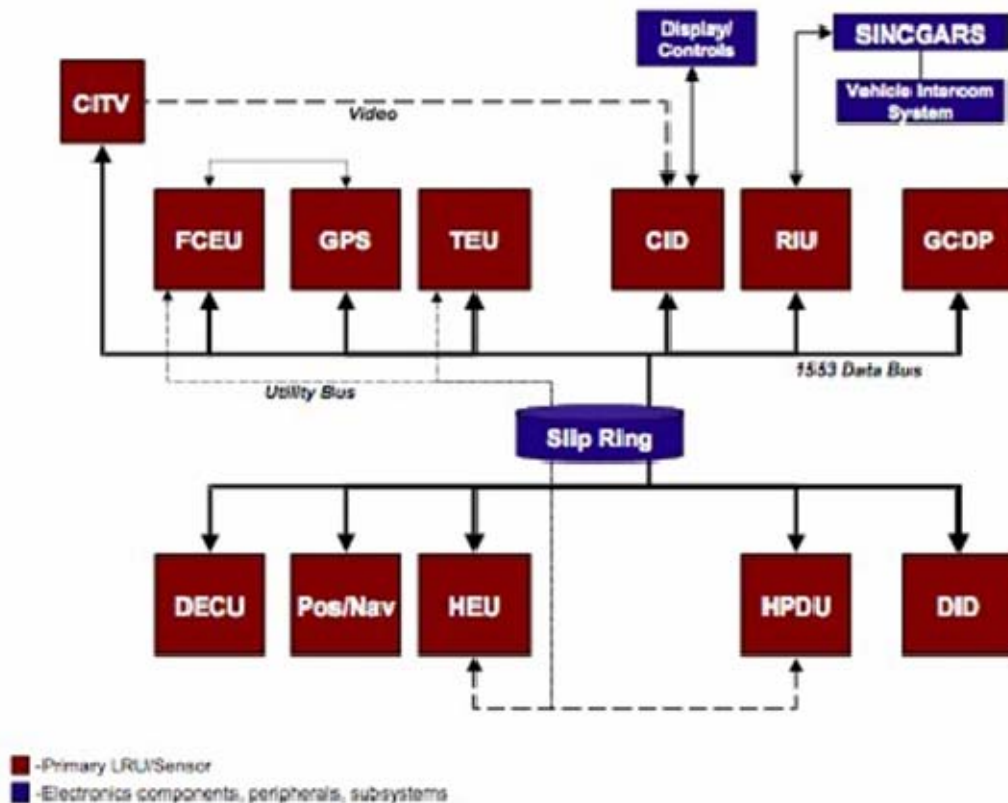

Figure 3. M1A2 System Diagram

The M1A2 system diagram is intended to identify the primary computational system elements and their interconnections and is not intended to identify the complete system architecture.

**B. M1A2 HARDWARE ARCHITECTURE**

The M1A2 is comprised of a series of primarily VME based LRUs, which are functionally allocated to perform various system tasks, described below.

LRU	Description
CITV	The Commander's Independent Thermal Viewer (CITV) provides the tank commander with an independent stabilized thermal sight with continuous 360-degree surveillance. The CITV also provides for hunter/killer capability, selected sector autoscan, search and gun line of sight modes, and a backup firing/sight system.
FCEU	The Fire Control Electronics Unit (FCEU) provides for fire control system integration through stabilization control, weapon firing control, operating state control, ballistic offset insertion, and ballistic parameter collection.
GPS	The Gunner's Primary Sight (GPS) is coordinated with the FCEU in order to provide for gun LOS, gun control, thermal/optics control and range data.
H/TEU	The Hull/Turret Electronics Unit (H/TEU) perform various primary and backup system control functions listed below.
CID	The Commander's Integrated Display (CID) provides for all operator Command, Control, and Communication's functions. This includes IVIS/RIU and SINCGARS operation as well as the preparation and disposition of tactical information. In addition, the CID also provides for the controls of the CITV and the display of both CITV imagery and system BIT status.
RIU	The Radio Interface Unit (RIU) provides an interface between the Single Channel Ground Airborne Radio System (SINCGARS) and the core vehicle electronics. The RIU provides for control of the SINCGARS transmitter, receiver, and crypto functions, manages the radio net, processes and manages radio message packets, algorithmically corrects transmission errors, and performs built in test.
GCDP	The Gunner's Control and Display Panel provides for the selection of ammo sub designate for the currently selected round, allows manual entry of sensor inputs for ballistic computations, provides GCDP panel built in test, and provides IFTE, CEE, and DSESTS test interface.

LRU	Description
DECU	The Digital Electronics Control Unit (DECU) provides for the primary interaction with and control of the vehicle engine. The EAJ6 DECU provides a 1553 system interface, which is utilized for systems interfacing and application downloading via the software loader verifier.
POS/NAV	The Position Navigation Unit (POS/NAV) provides the commander/driver navigation functions with tank heading and position data. In addition, the POS/NAV unit provides tank azimuth angular rate, tank pitch and roll angles for dynamic cant generation, and allows startup with self-initialization, stored heading, or manually input heading.
HPDU	The Hull Power Distribution Unit (HPDU) controls power to the Remote Switching Modules (RSMs), controls power to the Power Control Modules (PCMs), provides power and switching to localized loads, houses the vehicle NATO slave receptacle, and controls master power via the primary power interrupter.
DID	The Driver's Integrated Display (DID) provides engine and vehicle automotive command, engine control unit display, vehicle heading and steer to functions, drivers built in test.

Table 1. Primary and Backup Systems

The CID, DID, GCDP, RIU, H/TEU, FCEU, and POS/NAV LRUs form the core system computing environment for the M1A2 baseline.

The M1A2 system is comprised of additional components, not identified here. Most of these components are hardware-based units providing additional system inputs/output data and control. These components include position sensors, ballistic/environment sensors, analog input modules, remote switching modules, and operator handles/switch panels.

### C. M1A2 SOFTWARE ARCHITECTURE

The M1A2 software is partitioned to functionally match the M1A2 system design. The software is subdivided into Computer Software Configuration Items (CSCIs), which correspond to each M1A2 system LRU capable of performing computational data processing. A CSCI is further divided into Computer Software Components (CSCs), which map to major system functions and are resident on the various processors contained within each system LRU. The CSCs are further subdivided into Computer

Software Units (CSUs), which implement required CSC functionality. The software functional mapping to M1A2 system LRUs for the baseline M1A2 is depicted below in Figure 4 (TARDEC 2002).

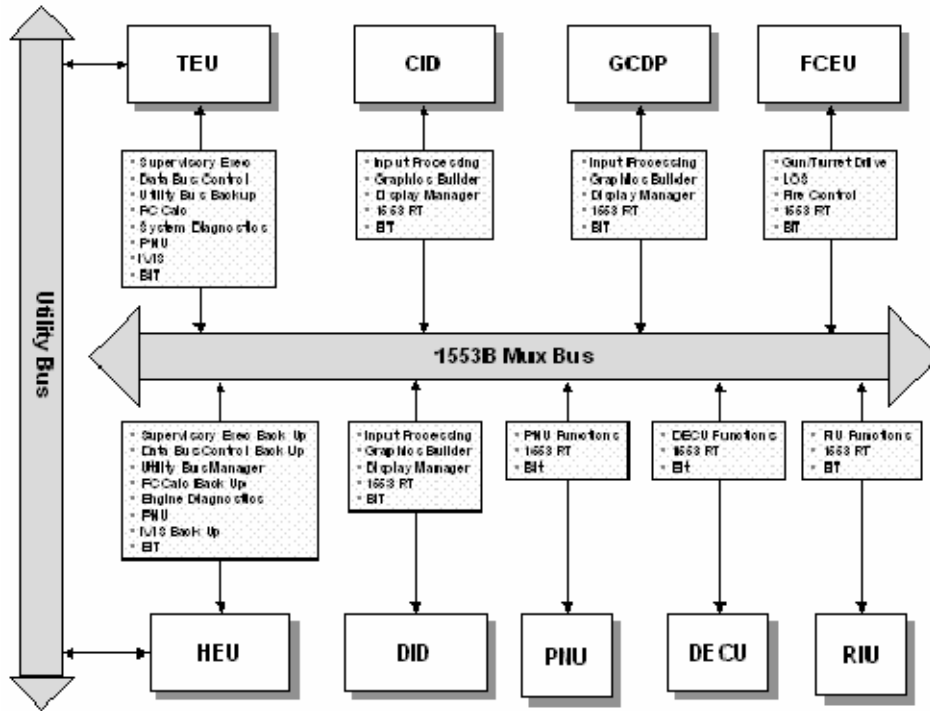

Figure 4. M1A2 Functional Software Diagram

The M1A2 baseline software was primarily programmed utilizing Mil-Std 1815, the Ada Programming Language. MC68020 assembly language and ANSI C were also used.

#### D. MIL-STD-1553 DIGITAL TIME DIVISION COMMAND/RESPONSE MULTIPLEX DATA BUS

##### 1. Hardware Description

The 1553 MUX Bus uses a dual-redundant bus configuration (A and B). Each bus uses a 78-Ohm twisted, shielded, pair cable with 78 Ohm terminators. Terminal equipment is transformer isolated (TARDEC 2002).

## 2. Protocol Description

All message transfers are twenty bit-time events at 1 MHz. The first three bits are synchronization, the next 16 bits are message data content, and the last bit is parity.

S0	S1	S2	0	1	2	3	4	5	6	7	8	9	10	11	12	13	14	15	P
----	----	----	---	---	---	---	---	---	---	---	---	---	----	----	----	----	----	----	---

The synchronization waveform for the Command and Status Words is an invalid Manchester of three bits duration: positive for 1½ bit times and negative for 1½ bit times. The synchronization waveform for Data Words is inverted. The bit parity for all words will be an "Odd Ones" on the 16 data bits.

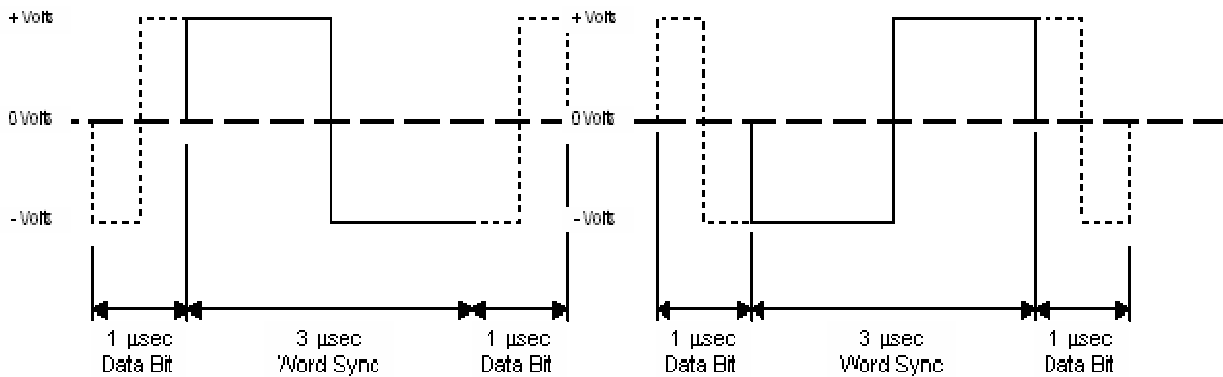

## 3. 1553 Data Bus Message Content

The data code is Manchester II bi-phase. A logic one will be transmitted as a bipolar coded signal of 1/0 (i.e., a positive pulse followed by a negative pulse). A logic zero will be a bipolar coded signal of 0/1 (i.e., a negative pulse followed by a positive pulse).

Bit values of the data content of each message will be from MSB to LSB, in the order received.

15	14	13	12	11	10	9	8	7	6	5	4	3	2	1	0
MSB	X	X	X	X	X	X	X	X	X	X	X	X	X	X	LSB

**4. 1553 Data Bus Command Word**

The data content of the Command Word generated by the Bus Controller (BC) to the Remote Terminal (RT) has the RT address in the upper (most significant) five bits, followed by the Transmit/Receive bit, the five-bit message sub address/mode field, and the five-bit data word count/mode code field.

15	14	13	12	11	10	9	8	7	6	5	4	3	2	1	0
Remote Terminal Address					TR	Message Sub address/Mode					Data Word Count/Mode Code				

No Data Words follow the Command Word if the Transmit/Receive bit is set (Transmit). Bits five through nine indicate either a message sub address (“00001” through “11110”) or flag a mode code in bits zero through four (“00000” or “11111”). If a receive message sub address is indicated, a data word count (“00001” through “11111”, and “00000” for 32) appears in bits zero through four. If a mode command is indicated, the RT bus terminal hardware traps it and responds appropriately.

The data content of the Data Words which accompany the Command Word when the Transmit/Receive bit is reset (Receive) have the appropriate content for that message as described in Data Packet Specifications Volume 1 through 11, DP-SA15132 Data Packet Specifications for M1A2 Main Battle Tank.

**5. 1553 Data Bus Status Word**

The Status Word from the RT to the BC has the RT address in the upper five bits, the Message Error bit in 10, The Instrumentation bit in nine, the Service Request bit in eight, The Broadcast Command Received bit in four, the Busy bit in three, the Subsystem Flag in two, the Dynamic Bus Control Acceptance bit in one, and the Terminal Flag in zero. Bits nine, five through seven, three, and one will be logic zero as these bits are not currently utilized.

15	14	13	12	11	10	9	8	7	6	5	4	3	2	1	0
Terminal Address					ME	IN	SR		BR	B	SF	DC	TF		

The Message Error bit is set by the RT after a Command Word with an invalid message sub address and Transmit/Receive combination, or if a receive message is short of its Data Word count, failed word parity validation, has improperly timed data synchronization, or has non-contiguous data. If the Message Error bit is set, it is cleared for the next message, barring subsequent errors. The Instrumentation bit is undefined. The Service Request bit is set by the RT to initiate a transmit or receive transaction. The Broadcast Command Received bit is set when the preceding valid command is a broadcast command. The Broadcast Command Received bit is reset when the next valid command is received, except in the cases of a transmit status word and transmit last command. The Busy bit is set by the RT when no further messages can be processed until the busy condition is cleared. The Subsystem Flag is set to when a fatal operating fault occurs in the RT. The Dynamic Bus Control Acceptance bit is used by alternate BC's only. The Terminal Flag bit is set by the RT if the Message Error, Service Request, or Busy bits are set. The Terminal Flag is set for a fatal operating fault condition in the RT bus terminal hardware.

#### 6. 1553 Data Bus Data Word with Status Word

The data content of the Data Words which accompany the Status Word, regardless of the Service Request bit setting, when the preceding Command Word was a transmit command will have the appropriate content for that message.

The data content of the Data Word which accompanies the Status Word when the Service Request bit is set and the preceding Command Word was not a transmit command will have zeros in the upper five bits, the Transmit/Receive bit in 10, the five-bit message sub address field in five through nine, and the five-bit data word count field in zero through four. This status response conformation is used only when an RT requires an exception, rather than periodic servicing.

15	14	13	12	11	10	9	8	7	6	5	4	3	2	1	0
						TR	Message Sub address					Data Word Count			



## 7. 1553 Data Bus Message Transfer

Inter-message gap and RT response times depicted are consistent with the requirements of MIL-STD-1553B.

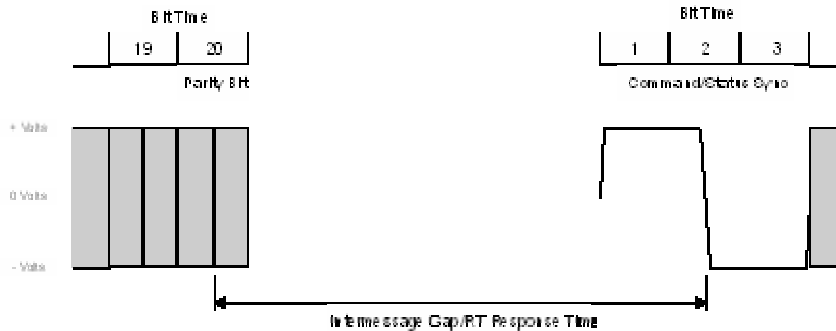

The BC provides a minimum gap time of four microseconds between messages. The RT responds to a valid Command Word within a period of four to 12 microseconds. The minimum wait time between the last Data Word of a message transmitted by the BC and the receipt of a Status Word generated by the RT is 14 microseconds.

## 8. 1553 Data Bus BC to RT Sequence

In the BC to RT transfer sequence, the BC transmits a Command Word with its Transmit/Receive bit reset to indicate the RT will receive. The Command Word is followed by a sequence of one to 32 Data Words generated by the BC. The Command and Data Words are transmitted in a contiguous fashion with no interword gaps. The RT responds with a Status Word.

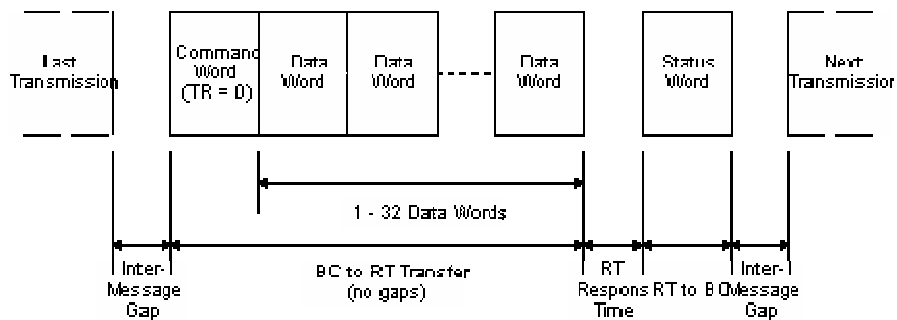

## 9. 1553 Data Bus RT to BC Sequence

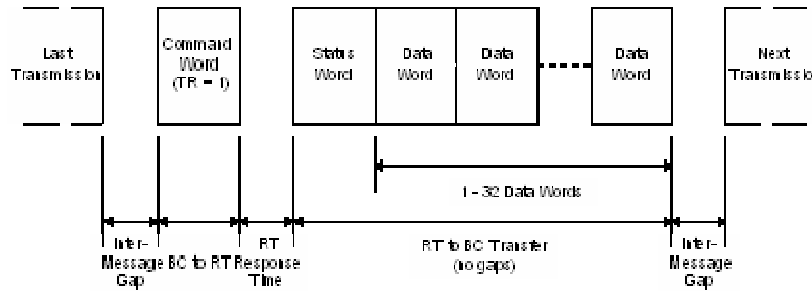

In the RT to BC transfer sequence, the BC transmits a Command Word with its Transmit/Receive bit set to indicate the RT will transmit. The RT responds with a Status Word followed by a sequence of one to 32 Data Words generated by the RT. The Status and Data Words are transmitted in a contiguous fashion with no interword gaps.

## 10. 1553 Data Bus RT to RT Sequence

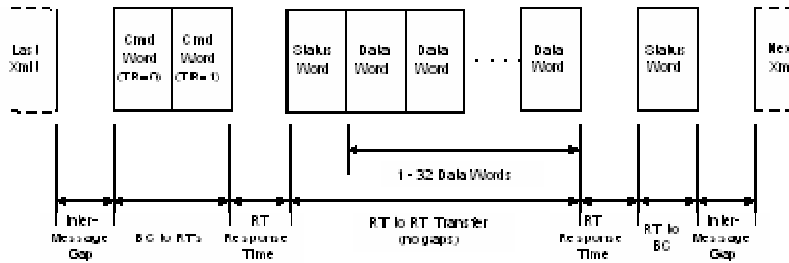

In the RT to RT transfer sequence, the BC transmits contiguously two Command Words, one with the Transmit/Receive bit reset to indicate the receiving RT and one with the Transmit/Receive bit set to indicate the transmitting RT. The Command Words are followed by a sequence of a Status Word and one to 32 Data Words generated by the transmitting RT. The Status and Data Words are transmitted in a contiguous fashion with no interword gaps. The receiving RT responds with a Status Word.

THIS PAGE INTENTIONALLY LEFT BLANK

### III. REQUIREMENTS AND SPECIFICATION

#### A. REQUIREMENTS FOR IMA

This section specifies the requirements that were used to develop the IMA prototype, a real time diagnostics tool for repairing ground combat systems. The system was designed to provide the vehicle maintainer an accurate and reliable means to diagnose and repair the vehicle, using the vehicle's own on board diagnostics capability in conjunction with the technical manuals (document lookup capability) and an easy to use Graphical User Interface (GUI). The system also includes additional software and hardware interfaces from SBS Technologies for the 1553 Data bus to provide remote terminal, bus controller emulation and interface to the SPORT or equivalent computer that hosts the IMA as shown in Figure 5 below.

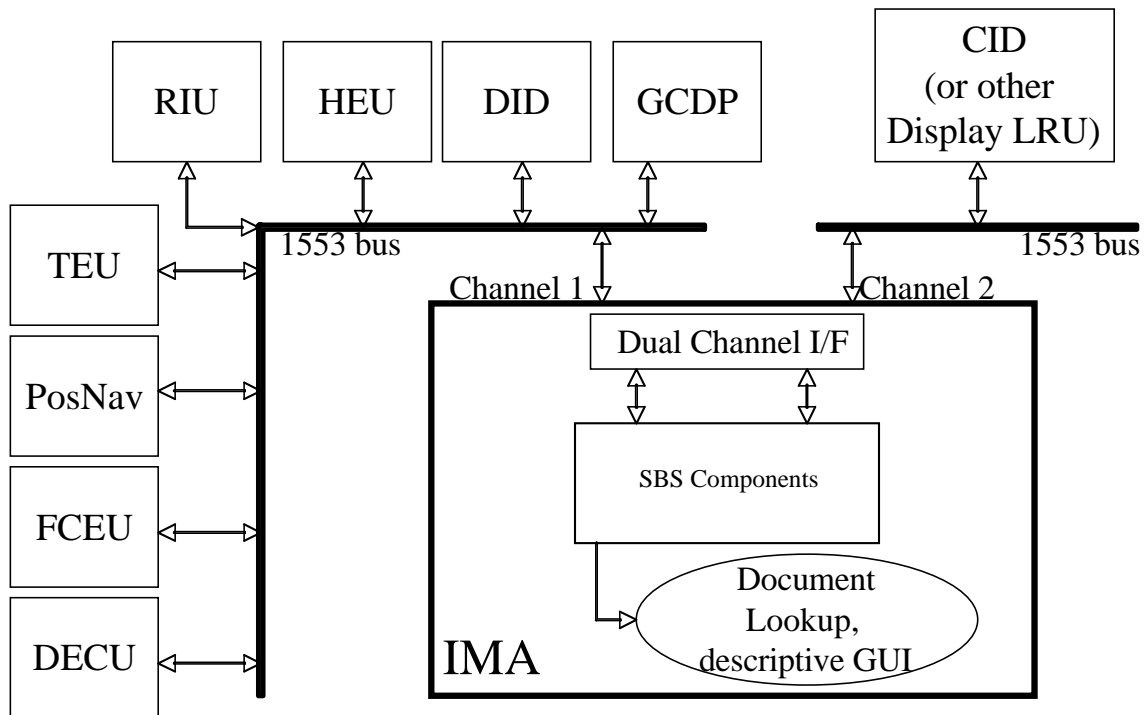

Figure 5. IMA Interfacing with the M1A2 tank

The IMA will be operating in an environment with the real TEU (bus controller) and real H/TEU (Back-up Bus controller).

## **1. System Goals**

The IMA system shall be required to provide real-time access to technical/maintenance documentation enabling the user (maintenance personnel or engineers) for improved turn-around/de-bug time for repairs. The goals of the IMA are (1) to provide the user with rapid on-site repairs and (2) reduce cost of performing Combat Sustainment Support (CSS) without reducing war fighting capability or readiness.

The IMA is a semi-autonomous system capable of functioning for extended periods of time with minimal maintenance support. The IMA shall be provided in a C++ runtime-software package and Windows development environment.

## **2. Assumptions and Dependencies**

The following assumptions and dependencies have been defined in order to simplify the development of the IMA:

- The IMA shall fully support all known/used data bus configurations.
- The IMA must use current Soldier Portable On-Board Repair Tool (SPORT or equivalent computer) platform as not to increase of development costs.

## **3. Requirements/Function Assumptions**

- The IMA shall be developed on/for Windows based platforms.
- C++ shall be used in the development of Intelligent Maintenance Aid.
- No special tools or test measurement device equipment are necessary/required.
- The IMA can be operational 24 hours a day provided the SPORT or equivalent computer device is powered by an AC power source.

## **B. SYSTEM FUNCTIONS**

### **1. Required States and Modes**

The system shall be ready to operate at all times. The IMA provides for two modes of operation; test mode or look-up mode. Test mode provides access to vehicle system level BIT and FIT diagnostics operations through data bus communications. Look-up mode provides access to the on board technical manuals for reference.

### **2. System Capability Requirements**

#### ***a. User Input***

The system shall be capable of accepting user input from buttons located either at the internal or the external keyboard on the SPORT or equivalent computer. Presentation of user input requests shall be done through a Graphical User Interface (GUI) used on the SPORT or equivalent computer.

#### ***b. Provide User Feedback***

The system shall be capable of providing appropriate feedback to the user through a Graphical User Interface (GUI) used on SPORT or equivalent computer.

#### ***c. System Response***

The system shall be capable at a minimum, of starting and stopping on desired selection(s).

#### ***d. Communication Coordination***

The IMA system will efficiently coordinate communication between the SPORT or equivalent computer and the vehicle under test by use of data bus communication ( i.e., 1553, RS-232, etc.).

Ref#	Function	Thesis Para.Ref.	Category	Use Case Association
R1	Start SPORT or equivalent computer	III.B.2.a		
R1.1	Enter Log-In & Password	III.B.2.a & III.B.2.b	Evident	U1
R1.2	Select IMA Application	III.B.2.a, III.B.2.b & III.B.2.c	Evident	U1
R2	Modes of Operation			
R2.1	Test Mode	III.B.2.a, III.B.2.b & III.B.2.d	Evident	U2
R2.1.1	Run BIT Test on vehicle and results to be displayed on IMA.	III.B.2.b, III.B.2.c & III.B.2.d	Evident	U2
R2.1.2	Run FIT Test from both the vehicle and IMA.	III.B.2.b, III.B.2.c & III.B.2.d	Evident	U2
R2.1.3	IMA maintains knowledge of TP numbers and displays results	III.B.2.b, III.B.2.c & III.B.2.d	Hidden	U2
R2.2	Look-up Mode	III.B.2.a, III.B.2.b & III.B.2.c	Evident	U2

Table 2. System Functions

Ref#	Function	Cat.	Attribute	Details & Constraints	Cat.
R1.1	Enter Log-In & Password	Evident	Security	(Boundary Constraint) Log-In and password necessary for restricted access.	must
R2.1	Test Mode	Evident	Provides for BIT and FIT tests	(Boundary Constraint) BIT test must be run before FIT test.	must
R2.1.3	IMA maintains knowledge of TP numbers and displays results	Hidden	LRU Monitoring	(Boundary Constraint) Results of BIT and FIT Tests and displays results. Must be reset before other test can run.	must
			Programming Language	(Detail) C++	must

Table 3. System Attribute Table

**C. USE CASE DIAGRAM**

The USE case shown in Figure 6 depicts the relationship between the actors (in this case the maintenance operator and vehicle system) to the IMA system (Craig Larman 1997).

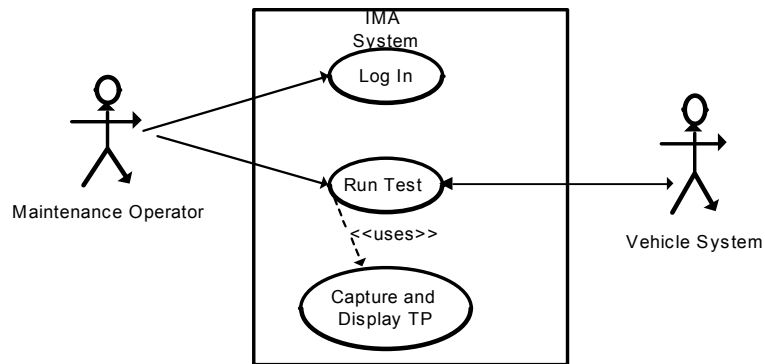

Figure 6. High Level Use Case



**D. USE CASE SCENARIOS**

**1. Use Case 1: Log In**

Use case: **Log In**  
Actors: Maintenance Operator (initiators)  
Purpose: To log in to SPORT or equivalent computer to access the IMA System  
Description: Maintenance Operator provides password SPORT or equivalent computer to gain access to the IMA system.  
Type: Primary and essential  
Cross-references: R1.1, R1.2

*a. Typical Course of Events*

Actor Action	System Response
	1. SPORT or equivalent computer requests Log in and password.
2. Maintenance Operator enters Log in and password into the SPORT or equivalent computer.	
	3. SPORT or equivalent computer accepts/denies Log in and password. Brings up start-up screen.
4. Maintenance operator selects IMA icon to start software application.	
	5. IMA screen is on and ready to use

## 2. Use Case 2: Run Test

Use case: **Run Test**

Actors: Maintenance Operator (initiators)

Purpose: To perform Vehicle System BIT and FIT tests.

Overview: Maintenance operator initiates test by running Built-In-Test (BIT) on the Vehicle System diagnostics menu first, then starts the IMA FIT monitor and initiate the Fault Isolation Test (FIT) from the Vehicle System diagnostics menu.

Type: primary, secondary and essential

Cross-references: R2.1, R2.1.1, R2.1.2, R2.1.3

### *a. Typical Course of Events*

Actor Action	System Response
1. Maintenance operator initiates BIT test from Vehicle System diagnostics menu.	
	2. Vehicle System begins BIT.
	3. Vehicle System completes and displays BIT results on IMA.
4. Maintenance operator starts the IMA FIT monitor and then initiates FIT test from the Vehicle System diagnostics menu.	
	5. Vehicle System completes FIT Test and displays results on IMA FIT Monitor and vehicle.

E. SYSTEM CONTEXT DIAGRAM

# Intelligent Maintenance Aid

## System Context Diagram

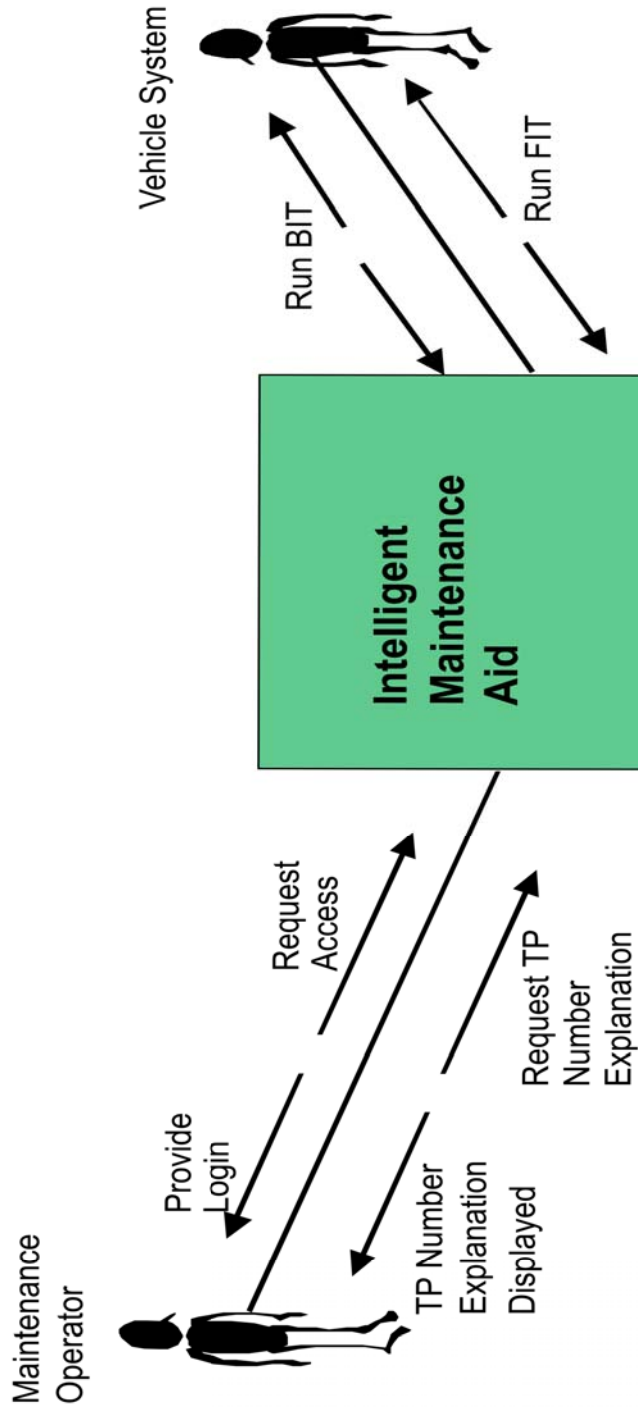

Figure 7. IMA System Context Diagram

Event	System Response	Dir. Pat.	Arrival Pattern	Sync Pattern
Enter Log-In and Password.	SPORT or equivalent computer allows access to IMA application program.	IN	Episodic	Sync
executeTest(BIT)	Execute BIT on system	IN	Episodic	Sync
executeTest (FIT)	Collects diagnostic data from BIT Test to pass on to FIT test for TP look up table.	IN	Episodic	Sync
executeTP Look-up (TP)	Displays results from FIT test to TP look up table.	IN	Episodic	Sync
reset (System)	System must be reset to clear previous results.	IN	Episodic	Sync

Table 4. External Events

Table 4 describes the external events to the IMA system based on events, system response, direction pattern, arrival pattern, and sync pattern.

**F. CONCEPTUAL DIAGRAM**

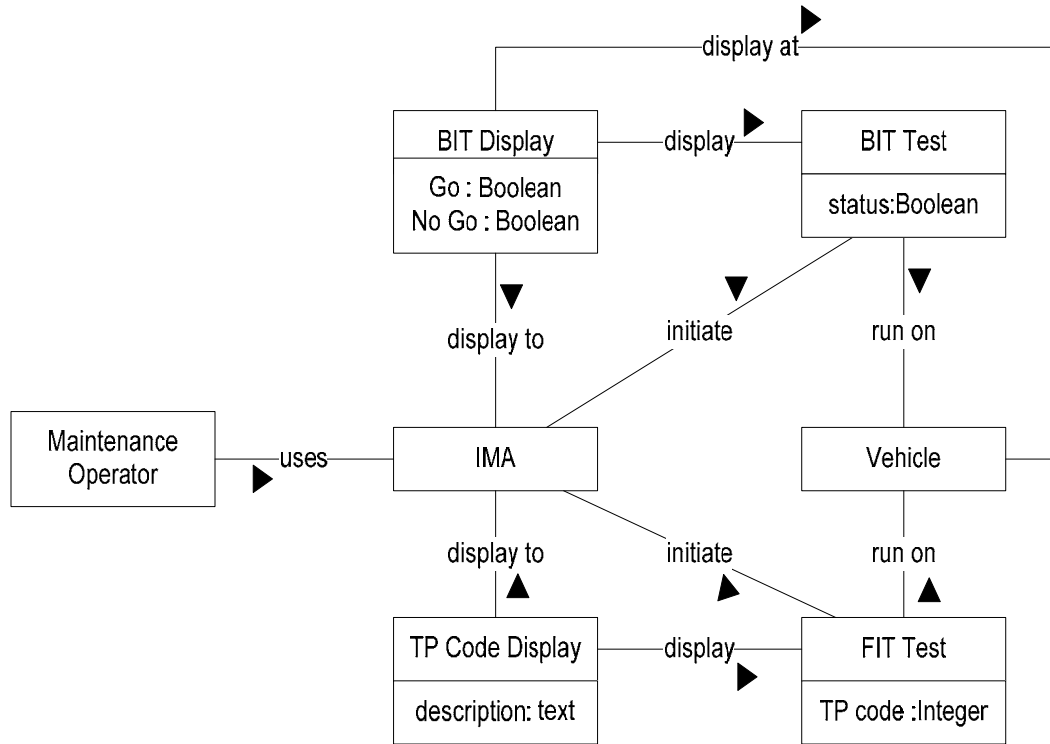

Figure 8. IMA Conceptual Diagram

## G. SYSTEM SEQUENCE DIAGRAM

# Intelligent Maintenance Aid

## System Sequence Diagram

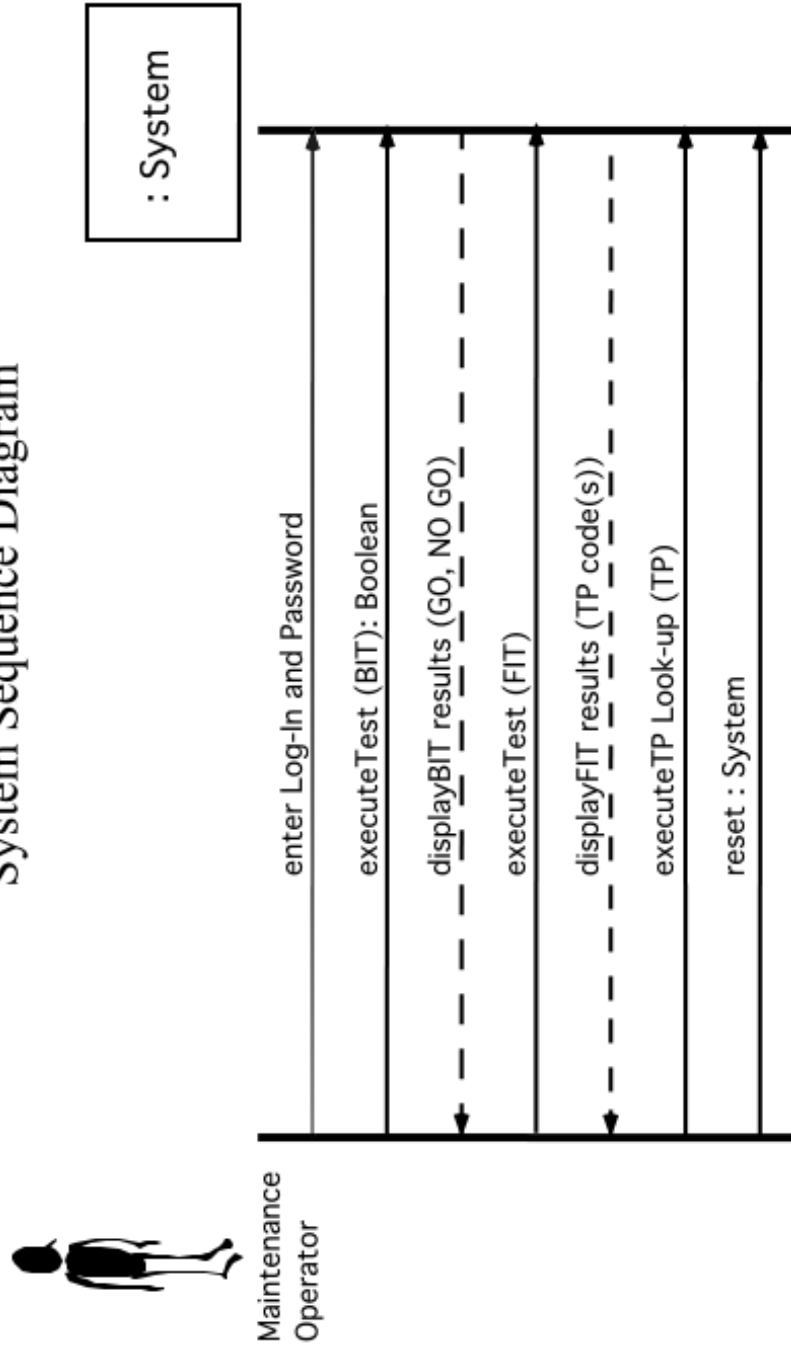

Figure 9. IMA System Sequence Diagram

## H. GLOSSARY

Term	Category	Comments
Maintenance Operator	Type	Personnel responsible for maintaining Intelligent Maintenance Aid and associated equipment
Vehicle System	Type	Generic term used for describing vehicle under test
Log-In	Use Case	Description of operator entering Log-In and password data
Run Test	Use Case	Description of operator performing BIT and FIT tests
Display BIT Results: Boolean	Attribute	Description of GO and NO GO status of LRUs.
Troubleshooting Procedure Codes (TP): Integer	Attribute	Description of errors associated with running BIT and FIT tests.

Table 5. Glossary of Terms

## IV. SOFTWARE ARCHITECTURE DESIGN

### A. INTRODUCTION FOR EMBEDDED DIAGNOSTICS FOR M1A2 TANK

Figure 10 presents a high-level view of the Fault Management in a M1A2 Tank (GDLS S/SDD 2003).

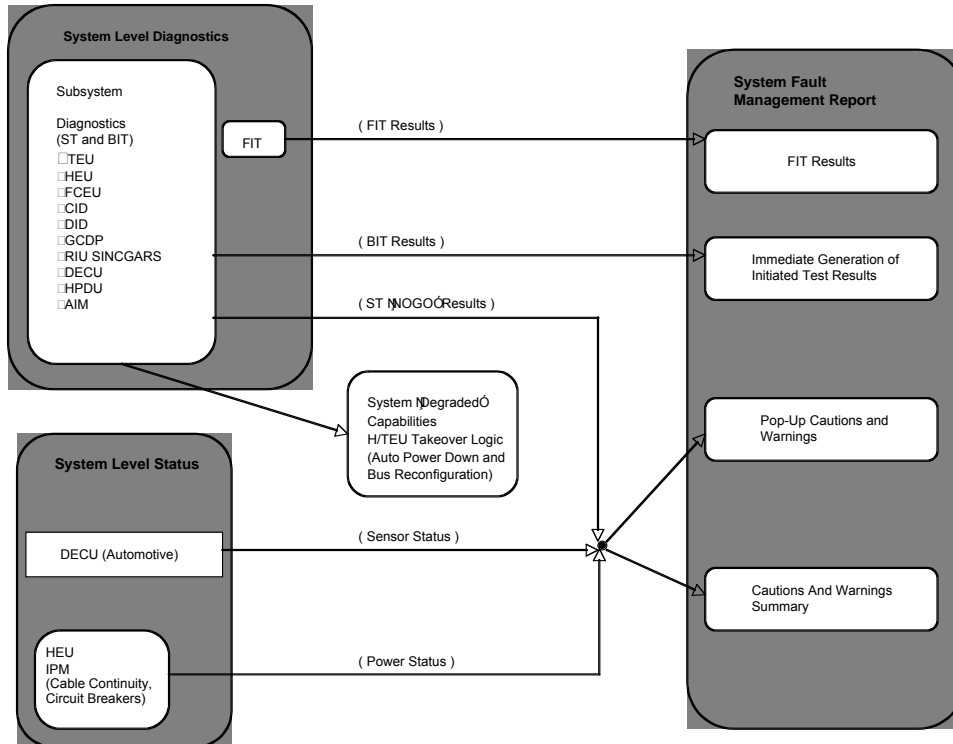

Figure 10. Operation and Status of Fault Management

The System Level Diagnostics is made up of three nested levels:

- Self Test (ST)
- Built-In-Test (BIT)
- Fault Isolation Test (FIT)

ST is the first level of diagnostics to detect a failure. Upon detection of a failure, the crew is made aware of a failure condition via the display mechanism described in the



next section. If ST detects a failure or the crew suspects something is malfunctioning, further diagnostic testing is essential since ST has limited fault detection coverage due to its non-intrusive design. If the tank is in Pre/Post or Combat mode, no further testing is permitted until the crew transitions the tank into Diagnostics mode.

Once in Diagnostics mode, the crew may initiate the execution of Built-In-Test (BIT) to confirm a failure detected by ST or a suspected malfunction. BIT's fault detection is more comprehensive because it allows intrusive testing where necessary.

When ST or BIT detects fault conditions, the tank crew informs organizational maintenance of the situation relaying the extent of the failure information provided by ST or BIT. Unit maintenance, upon receiving the tank for problem resolution, confirms the existence of the fault condition by executing BIT again. If the maintenance crew determines that system BIT has isolated to a Line Replaceable Unit (LRU) level, the faulty LRU is replaced. If the maintenance crew determines that an LRU ambiguity group exists, the maintenance crew initiates Fault Isolation Test (FIT). This either resolves the ambiguity or confirms the existence of multiple failures. When BIT and FIT fail to isolate the failure to an LRU, the unit mechanic will then resort to manual troubleshooting procedures.

### **1. Self Test (ST)**

Self-Test is the first level of embedded diagnostics within the M1A2 tank. ST reports faults to the crew during all modes of operation. Self-Test data runs in the background of each LRU. ST runs upon power-up and performs a health check on the system without affecting tank functions. Each LRU, communicating on the bus, provides health status to the system. This health status will be interpreted by the system and reported to the crew in the form of a caution or warning pop-up on the appropriate displays. The 10 LRU's that make up the tank's architecture are:

- a. CID
- b. DID
- c. GCDP
- d. HEU
- e. TEU

- f. POS/NAV
- g. DECU
- h. CITV
- i. FCEU
- j. RIU

Each of the above 10 LRU's reports Self-Test data on the health of their own system. Self-Test data from each LRU is placed on the 1553 bus through data packet 30. Data packet 30 is the reporting mechanism for diagnostic data. Self-Test data is updated on the 1553 bus at a 1Hz rate. When an LRU detects a failure within its internal architecture, a bit will be set in data packet 30 from that LRU. Data Packet 30 results were evaluated by the bus controller. The TEU applies fault results to the generation criteria for Cautions and Warnings. If the TEU fails, the HEU (backup) will take over and invoke the Systems Level Diagnostics. If the generation criteria are met, a Caution or Warning will be output from the TEU/HEU. The TEU/HEU outputs Caution and Warning results on the 1553 bus through data packet 28 (see Figure 11). Data packet 28 contains the continuous update of all Caution and Warnings and is sent to all three displays (CID, DID, and GCDP). Only the Cautions and Warnings that are primary to each display will be shown.

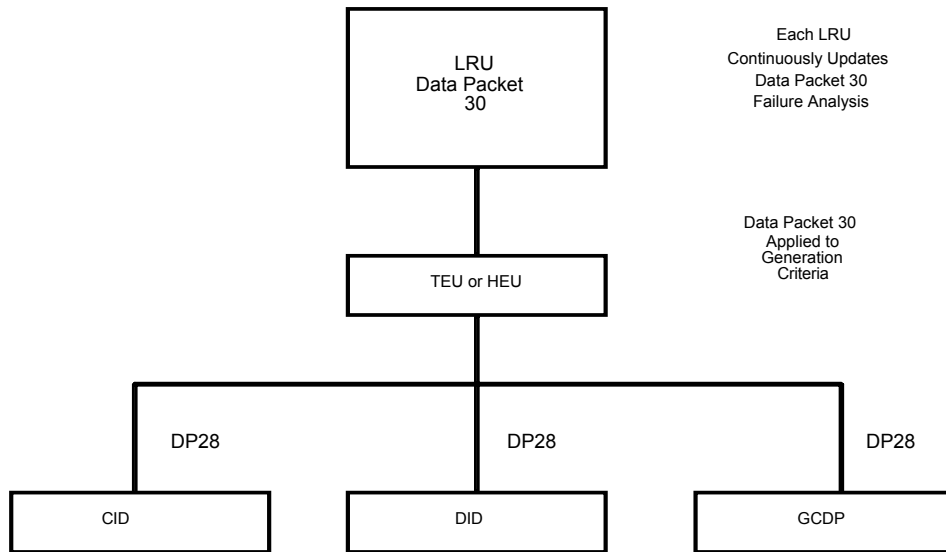

Figure 11. Data Packet Flow

## 2. Built-In-Test (BIT)

Built-In-Test is the second level of embedded diagnostics. BIT is an intrusive test of the system health status. BIT operates within the Diagnostic mode of operation and performs an intrusive test on various units when commanded by the operator. Once a unit is under BIT, it will not communicate within the system until it has completed intrusive testing of its internal architecture. The crew can perform a health check of the vehicle from all displays. From the Commanders display, the operator can perform a system BIT on all units. Once commanded into BIT each unit undergoes an intrusive testing of its internal architecture.

After completion of BIT, the tested units return BIT results, which are displayed as GO or NOGO. BIT performed at the driver's display will report hull-related diagnostic BIT results and the gunner's display will report turret related diagnostic BIT status. BIT can also be executed on the fire control system by running the FC SYSTEM TEST. The fire control system test can only be run from the GCDP in Operational mode with the gunners handle.

### **3. Fault Isolation Test (FIT)**

Fault Isolation Test is the third level of embedded diagnostics. FIT utilizes the results from Self-Test and Built-In-Test to reduce ambiguity groups within the system. The corresponding ST and BIT results are incorporated into variables. These variables make up several hundred Boolean equations to isolate faulty units and generate troubleshooting procedure (TP) numbers.

Maintenance crews can obtain a list of faulty units through Fault Isolation Testing. Once the unit is deemed faulty, the crew can replace the unit.

System Health categories also show up under FIT. System Health category contains:

- a. Cable Disconnects
- b. Power Management
- c. Utility Bus
- d. Data Bus Communications
- e. Hull Computer
- f. Turret Computer System
- g. Commanders Station
- h. Drivers Station
- i. Gunners Station
- j. Gun/Turret Drive System
- k. Weapons System
- l. Gun Positioning System
- m. Communications System
- n. Automotive System
- o. Hull System

Each categories will display a GO or NOGO condition. If a category is a NOGO, entering the category will reveal corresponding troubleshooting procedure numbers.

## **B. IMA PROTOTYPE**

The IMA is a PC based application. The application provides two basic capabilities: (1) a graphical representation of the real-time 1553 fault reporting, (2) HTML hyperlinked troubleshooting procedures for detected failures. To provide these capabilities the PC is equipped with a 1553 PCI card, existing TACOM ATE software, and maintenance manual documentation in HTML format. The ATE software (1553GUI) establishes transmit and receive buffers in the PC shared memory while also configuring the SBS 1553 for bus monitoring of desired 1553 remote terminals. The IMA connects to the PC shared memory to retrieve real-time remote terminal fault information. To provide “on-line” hyperlinked troubleshooting procedures, the IMA uses a simple static relational database. Existing maintenance manual documentation (pdf format) is converted to HTML. All page or procedure references within all manuals are parsed out and stored within the database. All HTML files along with the database reside on the local PC. Based on user IMA menu selections and the database, appropriate systems manual pages containing the needed troubleshooting procedures are presented.

## **C. REAL-TIME FAULT REPORTING**

Remote terminals in the M1A2 system provide real-time fault information in sub-address (message) number 30 via the 1553 data bus. Refer to Chapter II for the 1553 protocol description. IMA monitors this real-time data and provides a graphical depiction of all fault information via the System Display Window (Figure 12). Fault data for particular 1553 remote terminal are accessed by clicking on the desired terminal on the System Display Window. For example, selection the CID icon will invoke the CID Display Window shown in Figure 13.

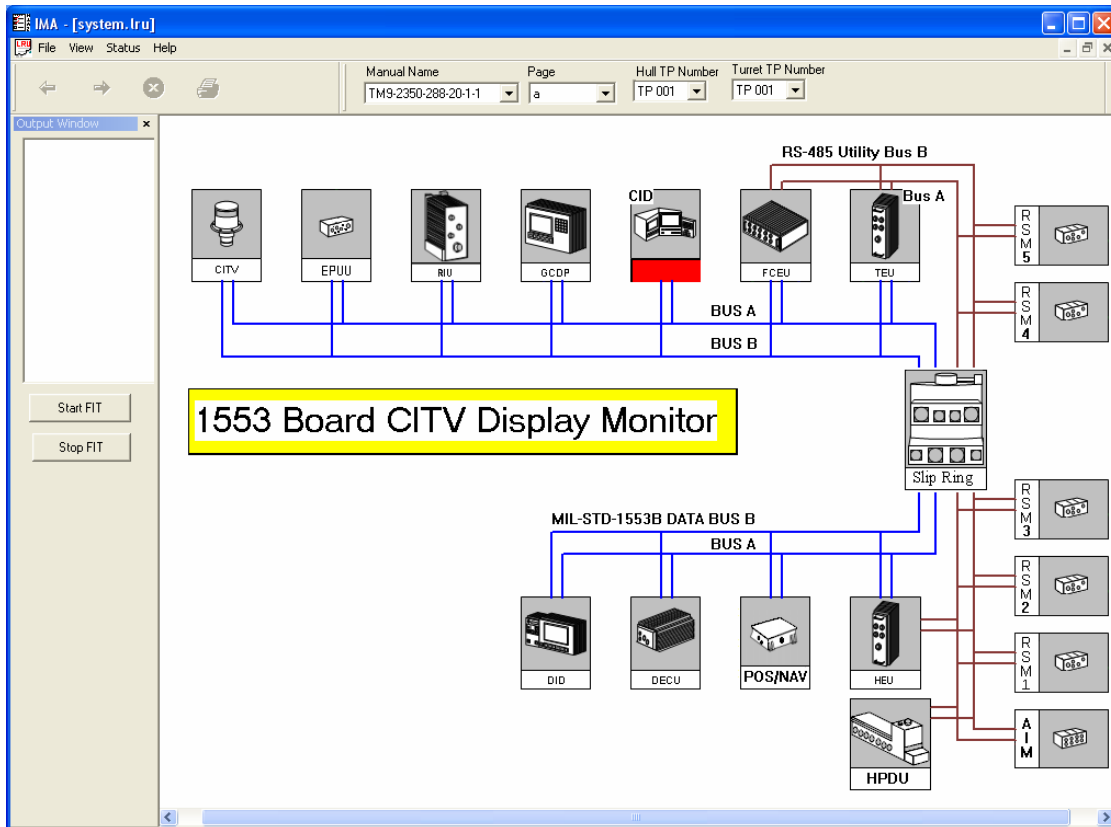

Figure 12. System Display Window

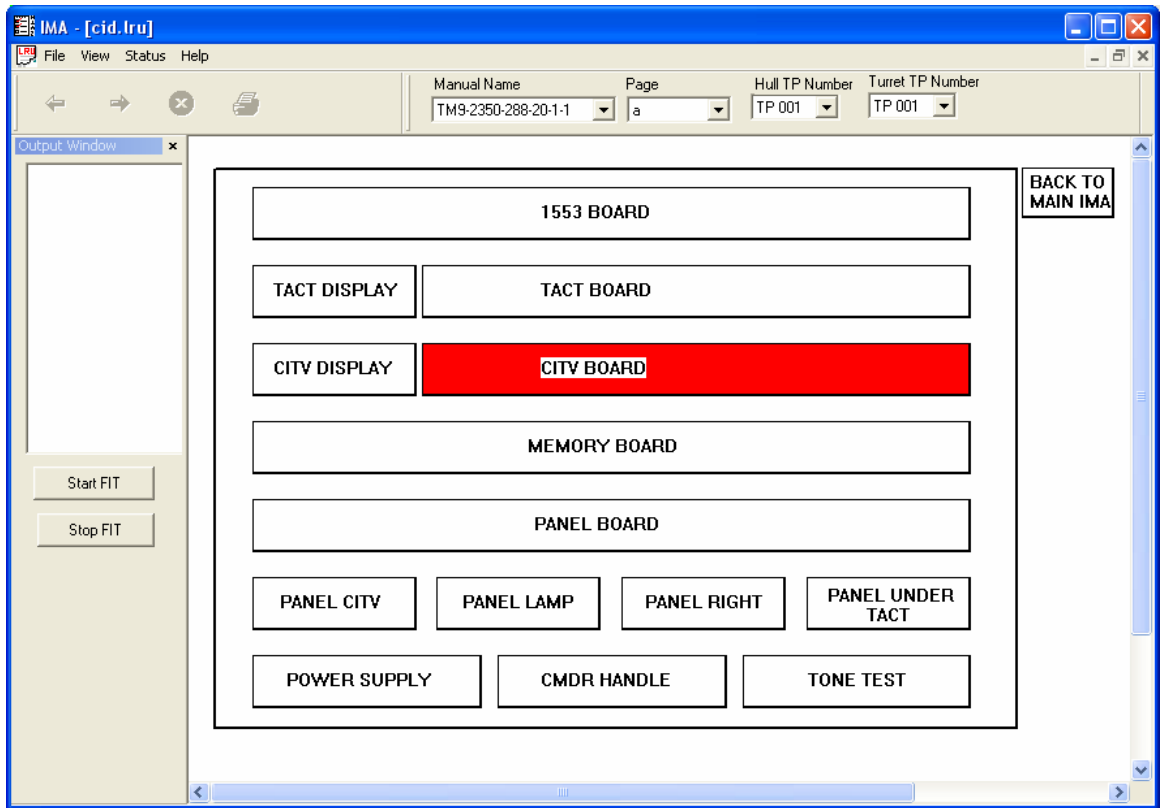

Figure 13. CID Display Window

#### D. FAULT DATA

In the M1A2 system, message 30 information is provided at 1 Hz rate. Message 30 can contain up to 32 16-bit data words. (Refer to Chapter II for the 1553 protocol description.) Specific fault data items for each remote terminal are assigned to a single bit within a 16-bit data word. Data words of message 30 are organized in a cascade arrangement for each remote terminal. There are three classifications of remote terminal faults: Type A, Type B, and Type C. The highest level fault reporting is for the remote terminal itself, and these are classified as “Type A” faults. Type A faults are located toward the front of message 30. The next level of fault data, “Type B” is assigned to a particular components of a remote terminal. Type B faults comprise the middle words of message 30. The lowest level items for a particular remote terminal component are classified “Type C”. Type C faults are at the end of message 30. “Type C” faults are rolled up to comprise the “Type B” faults. In turn, Type B faults are rolled up to

comprise the Type A faults. When a low level Type C fault occurs, it in turn sets a corresponding Type B fault, which in turn sets the Type A fault. Refer to Figure 14 for an example of message 30 structure.

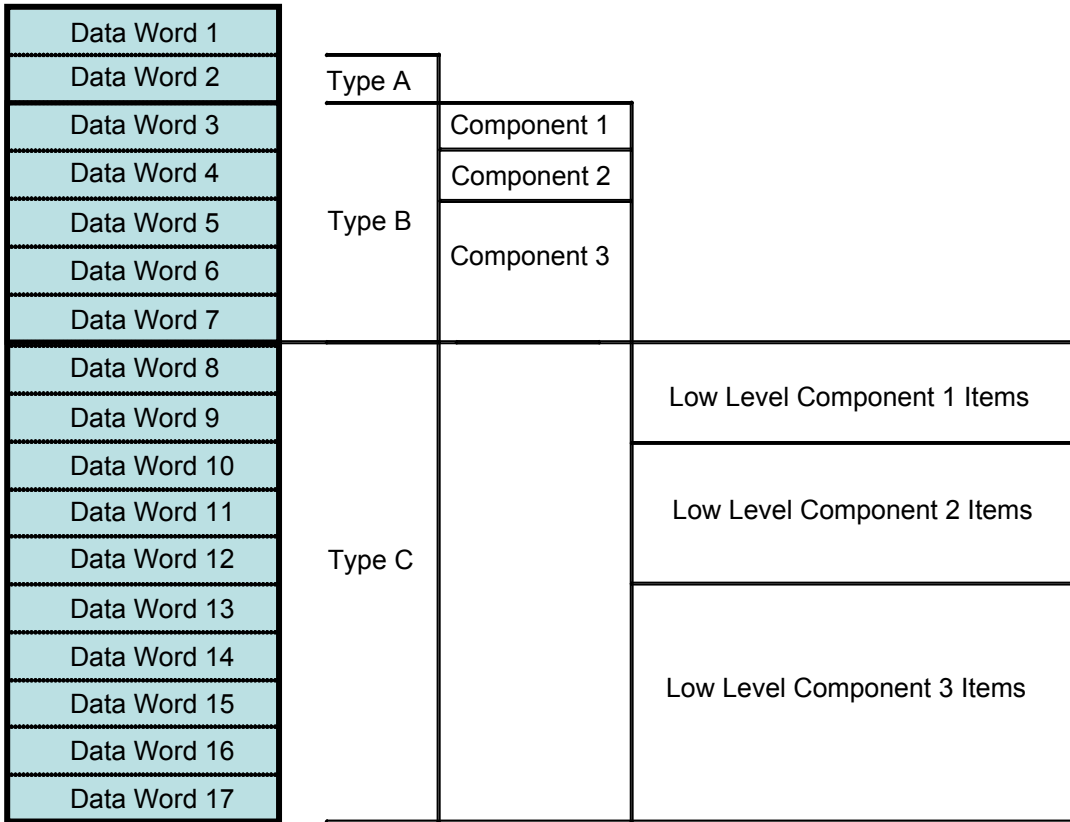

Figure 14. Sub-address 30 Organization

**E. GRAPHICAL FAULT CORRELATION**

In the M1A2 system, message 30 data words are enumerated according to the 1553 vehicle specification. The IMA BIT operations use the information extracted from a database table structure as defined in Table 5. Refer to MS Office 2000, or MS Office XP for Access database features and operation.



Data Field		Attributes						Usage
Field Name	Data Type	Field Size	Default Value	Required	Allow Zero Length	Indexed	Unicode Compress	
DPNum	Number	Integer		No		No		1553 Vehicle Protocol
DPTYPE	Text	50		No	No	No	No	
RT	Number	Byte		No		No		
SA	Number	Byte		No		No		
WordNum	Number	Integer		No		No		
StartBit	Number	Integer		No		No		
TotalBits	Number	Integer		No		No		
Owner	Text	50		No	No	No	Yes	Fault Enumeration
SubOwner	Text	30		No	No	No	Yes	
BIT/RPC	Text	10		No	No	No	No	
Message	Text	255		No	No	No	No	
Status	Number	Integer	0	No		No		
Type	Number	Integer	0	No		No		

\* All other attribute fields blank

Table 6. IMA Database Structure

All low level components are traced to the particular remote terminal components. The real-time data and database tracing is read, correlated, and presented graphically. For example, low level components such a CID 1553 watchdog timer or a CID 1553 real-time clock fault get traced to the 1553 board component. If either one of these is set, the M1A2 system also sets the Type B 1553 board fault along with the Type A terminal fault for the CID. What the IMA user sees graphically on the System Display Window, is a text box representation of the last detected detail failure and a RED flag on top of the CID icon in the System Display Window (Figure 12). The IMA user then clicks the CID icon to display the CID component graphical display. The terminal graphics display, in this case CID, is presented in a fashion that represents the terminal as if the real hardware box was open (Figure 13). At this component level, the 1553 board would show RED. The low level faults, in this case, 1553 watchdog timer or a 1553 real-time clock fault are displayed textually.

## **F. FIT SECTION**

The M1A2 system provides a FIT capability. FIT is executed after real-time faults have been detected. The M1A2 FIT process correlates documented troubleshooting procedures to these real-time faults. The troubleshooting procedures are indexed, numbered 1 through n. Based on the faults detected, the FIT outputs one or more TP numbers. Each of the troubleshooting procedures is an ordered set of instructions, when performed, designed to isolate the possible component(s) responsible for the faults detected.

## **G. FIT DATA**

Just as with the Graphical Fault Display, IMA connects to the PC shared memory to retrieve real-time 1553 TP FIT data. During the M1A2 FIT execution process two 1553 sub-addresses are used, sub-address 10 and sub-address 11. Refer to Chapter II for the 1553 protocol. The M1A2 system monitors sub-address 10 for the user initiation of FIT. As FIT executes, TP numbers are output on the 1553 data bus in sub-address 11. Each specific procedure index is assigned to a single bit within a 16-bit data word. Refer to Figure 15 for an example of the 1553 16-bit FIT data enumeration.

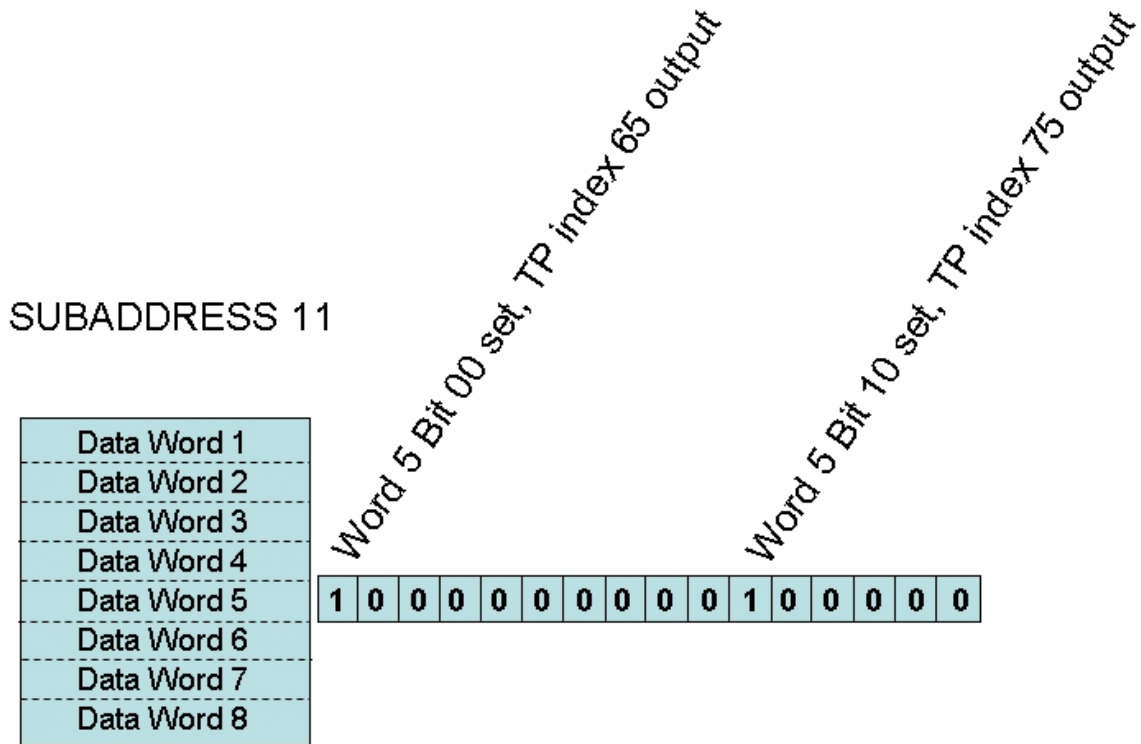

Figure 15. FIT Data Enumeration

## H. IMA FIT GRAPHICS

IMA reads the real-time FIT data from sub-address 11. IMA then applies bit-wise enumerations to extract the corresponding TP indexes. Note that the same MS Access database that stores the BIT fault data is used to store these FIT enumerations. After TP indexes are gathered IMA populates a GUI sub window with the list of TPs (see Figure 18).

Once TPs are gathered, real-time 1553 data is no longer needed. Maintenance crew need only follow the step-by-step instructions in the TP to pin point fault sources. Instead of requiring the maintenance crew to manually shuffle through procedures in the hardcopy manuals, or manually scrolling through electronic pdf files, the IMA provides hyperlinked HTML files that can be clicked to display the correct page in the maintenance manual. To provide this, the IMA uses a simple static relational database. Note that this is the same database that contains BIT and FIT enumerations. To populate

the database with needed hyperlink information a series of conversion and parsing was necessary, as illustrated in Figure 16.

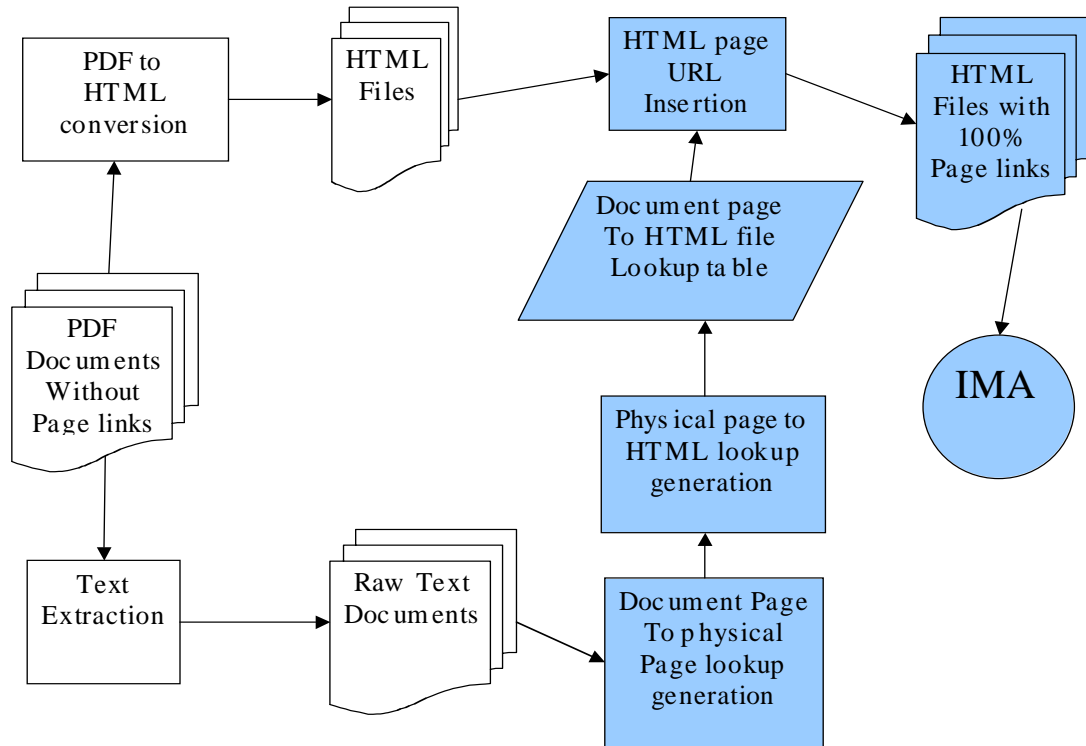

Figure 16. Conversion Process

## I. GENERIC HTML CONVERSION

Existing maintenance manual documentation (pdf format) is converted to HTML. An Adobe add-on product, Magellan, is used to parse the pdf maintenance manual documentation. The product parsed each pdf page of each manual to a unique HTML file. These unique HTML files were assigned names using a convention that including the manual volume, section, and page.

## J. PARSE PDF TEXT REFERENCES

The same pdf files were also converted to straight text. This allowed text parsing for the TP items themselves as well as other internal and external (different manual volume) page references. Within each HTML page there could exist many page references. This was easily handled with the relational database structure. All page or procedure references within all manuals are parsed out and stored within the database. TP numbers and page references were correlated to the raw HTML page and to the sectional page notation. This correlation data is stored in the MS Access database. For all identified references, the HTML file was updated with the hypertext attributes. All HTML files along with the database reside on the local PC. The local path is set under the File->Preferences menu, shown in Figure 17.

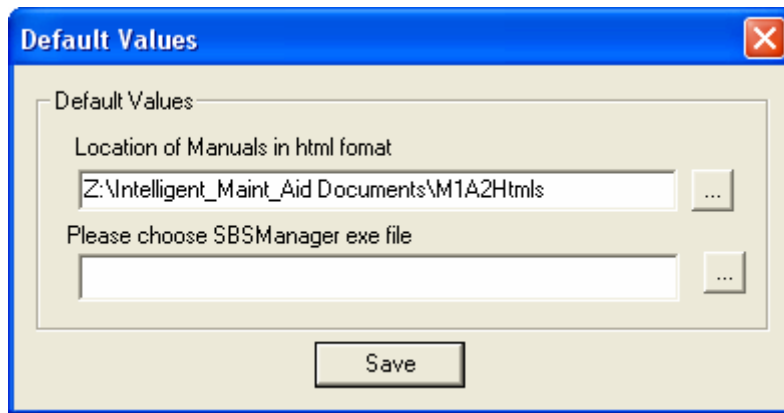

Figure 17. PDF Text Preference Location

Based on user IMA menu selections and the database, appropriate systems manual pages containing the needed troubleshooting procedures are presented. An illustration of the IMA FIT capabilities is shown in Figure 18 below for TP code 333. Clicking on the hyperlink for TP333 shown in Figure 18 yields the manual page 3-315 Figure 19.

IMA - [20-1-1\_273.htm]

File Edit Status View Window Help

Manual Name: TM9-2350-288-20-1-1 Page: a Hull TP Number: TP 001 Turret TP Number: TP 001

Output Window: TP 333, TP 605

TM 9-2350-288-20-1-1

**Built-in Diagnostics Fault Message Index (Continued)**

Message	Action
TP 330 XMSN SOLENOID E CB trip (RSM 1 RPC 6)	+ Do TP 330 Follow-on Procedure ( <a href="#">page 3-306</a> ).
TP 331 DRIVER DOME LIGHT CB trip (RSM 1 RPC 7)	+ If TPs 308, 328, and 334 are displayed with TP 331, do TP 301 Follow-on Procedure in this index. + If not, do TP 331 Follow-on Procedure ( <a href="#">page 3-314</a> ).
TP 332 HEADLIGHT HI BEAM CB trip (RSM 1 RPC 8)	+ Do TP 332 Follow-on Procedure ( <a href="#">page 3-303</a> ).
TP 333 2ND SHOT FIRE EXT CB trip (RSM 1 RPC 9)	+ Do TP 333 Follow-on Procedure ( <a href="#">page 3-315</a> ).
TP 334 FIRE EXT AMPLIFIER CB trip (RSM 1 RPC 10)	+ If TPs 308, 321, and 331 are displayed with TP 334, do TP 301 Follow-on Procedure in this index. + If not, do TP 334 Follow-on Procedure ( <a href="#">page 3-316</a> ).
TP 335 NBC BLEED AIR OFFON CB trip (RSM 2 RPC 2)	+ If TPs 337, 338, and 341 are displayed with TP 335, do TP 303 Follow-on Procedure in this index. + If not, do TP 335 Follow-on Procedure ( <a href="#">page 3-317</a> ).
TP 336 RIGHT FUEL XFR SOL CB trip (RSM 2 RPC 3)	+ Do TP 336 Follow-on Procedure ( <a href="#">page 3-319</a> ).
TP 337 NBC PRESS REG VALVE CB trip (RSM 2 RPC 4)	+ If TPs 335, 338, and 341 are displayed with TP 337, do TP 303 Follow-on Procedure in this index. + If not, do TP 337 Follow-on Procedure ( <a href="#">page 3-320</a> ).
TP 338 RADIAC DETECTOR CB trip (RSM 2 RPC 5)	+ If TPs 335, 337, and 341 are displayed with TP 338, do TP 303 Follow-on Procedure in this index. + If not, do TP 338 Follow-on Procedure ( <a href="#">page 3-321</a> ).
TP 339 HYDR BLOCK SOLENOID CB trip (RSM 2 RPC 6)	+ Do TP 339 Follow-on Procedure ( <a href="#">page 3-322</a> ).
TP 340 LEFT FUEL XFR SOL CB trip (RSM 2 RPC 7)	+ Do TP 340 Follow-on Procedure ( <a href="#">page 3-324</a> ).
TP 341 NBC BLEED AIR LOWHI CB trip (RSM 2 RPC 8)	+ If TPs 335, 337, and 338 are displayed with TP 341, do TP 303 Follow-on Procedure in this index. + If not, do TP 341 Follow-on Procedure ( <a href="#">page 3-325</a> ).
TP 342 FRONT FUEL XFR PUMP CB trip or no load (RSM 2 RPC 9)	+ Leave master power on. + Do TP 342 Follow-on Procedure ( <a href="#">page 3-327</a> ).
TP 343 RIGHT REAR FUEL PUMP CB trip or no load (RSM 2 RPC 10)	+ Leave master power on. + Do TP 343 Follow-on Procedure ( <a href="#">page 3-329</a> ).
TP 344 DRIVER DTV CB trip or no load (RSM 2 RPC 12)	+ Leave master power on. + Do TP 344 Follow-on Procedure ( <a href="#">page 3-332</a> ).

3-58 Change 4

Start FIT

Stop FIT

Figure 18. TP Code 333

IMA - [20-1-1\_273.htm]

File Edit Status View Window Help

Manual Name: TM9-2350-288-20-1-1 Page: a Hull TP Number: TP 001 Turret TP Number: TP 001

Output Window: TP 333 TP 605

TM 9-2350-288-20-1-1

### TP 333 FOLLOW-ON PROCEDURE

**Tools:**

- x Digital multimeter (Item 263, Appendix E)
- x Electrical connector slip joint pliers (Item 128, Appendix E)
- x Test lead set (Item 265, Appendix E)

**NOTE**  
Read Section I, How To Do Troubleshooting, before doing any work ([page 3-1](#)).

**1**

- x Set MASTER POWER switch to OFF.
- x Disconnect 2W125-8/P5 from J1 on engine second shot "re extinguisher valve" ([page 3-1013](#)).
- x Set MASTER POWER switch on driver's integrated display to ON.
- x Monitor hull circuit breaker status (RSM 1 2ND SHOT FIRE EXT)
  - x Refer to TM 9-2350-288-10.
  - x Set FIRE EXTINGUISHER 2ND SHOT switch on driver's integrated display to ON.

Did 2ND SHOT FIRE EXT circuit breaker status show tripped for approximately 5 seconds?

**YES** **NO**

**2**

- x Set FIRE EXTINGUISHER 2ND SHOT switch to OFF.
- x Set MASTER POWER switch to OFF.
- x Prepare multimeter for ohms test.
- x Disconnect 2W125-8/P1 from J7 on remote switching module 1 (2A102) ([page 3-1006](#)).

x Test for less than 5 ohms between contact B and contacts on 2W125-8/P5 listed below:

- x A
- x Connector body

Does multimeter show less than 5 ohms?

**YES** **NO**

**3**

- x Set FIRE EXTINGUISHER 2ND SHOT switch to OFF.
- x Replace engine compartment valve and bottle assembly (second shot) ([page 23-21](#)).
- x Verify problem is solved.

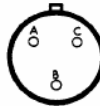

2W125-8/P5

**4**

- x Replace branched wiring harness 2W125-8 ([page 9-186](#)).
- x Verify problem is solved.

**5**

- x Connect 2W125-8/P5 to J1 on engine second shot "re extinguisher valve" ([page 3-1013](#)).
- x Replace remote switching module 2A102 ([page 9-72](#)).
- x Verify problem is solved.

Start FIT

Stop FIT

3-315

Figure 19. Hyperlink for TP333

## V. TEST AND EVALUATION

No formal testing was conducted during IMA development. The Visual C++ Compiler and Debugger tool were used during development. Bug tracking and software enhancements were kept informally. At various stages during development, IMA modules were tested at the integration level to ensure proper operation of the assembled code. After IMA development, the test effort would center on “functional” or “black-box” testing. “Glass-box” or “white-box” test methods were not employed because of the nature of IMA itself. IMA either hyperlinked to proper manual page or it did not. IMA either reported the correct system failure that was injected or it did not. Quantitative data would be gathered to evaluate IMA usage versus hardcopy manual usage.

### A. TEST GOALS

The IMA test goals were to validate the IMA fault reporting and to evaluate the time it took to trace TPs using hardcopy manuals usage versus the hyperlinked IMA manuals. Test goals were to be primarily satisfied by the demonstration method. Data will be injected in a controlled environment and IMA will be expected to produce known result. With regard to IMA hyperlinking, timing analysis will be used in conjunction with the demonstration method.

1. Interject BIT faults into the M1A2 system
  - a. Verify proper IMA top level system flag(s)
  - b. Verify proper IMA sub-system flag(s)
  - c. Verify proper IMA BIT fault isolation report(s)
2. Interject FIT faults into the M1A2 system
  - a. Verify proper IMA FIT data collection
  - b. Verify proper IMA FIT data reporting
3. IMA troubleshooting procedure hypertext linking
  - a. Verify page referencing
  - b. Gather timing data for TP tracing using hardcopy manuals usage versus the hyperlinked IMA manuals



**B. IMA TEST SETUP**

IMA is intended for connections to real system hardware. Fault insertions cannot be achieved on the vehicle at the lower board level with real system hardware. Specific 1553 terminal emulations were employed for fault insertions. These were already in place in the System Integration Lab (SIL) bench for the M1A2. The M1A2 SIL was the environment used for all testing.

**1. IMA BIT Capability**

To verify goals for the IMA BIT capability, two remote terminal configurations within the M1A2 SIL were used. In one configuration, the DID terminal was emulated. In the other configuration the GCDP terminal was emulated. The complete M1A2 terminal status for the two distinct test configurations is shown below. The corresponding emulation tool appearance can be viewed in Figure 20 and Figure 21.

*a. Simulated DID Configuration*

1553 Device	Status	Emulator Appearance (Fig #20)
HEU	Actual	Red Diamond
TEU	Actual	Red Diamond
DID	Emulated	Green Diamond
CID	Actual	Red Diamond
DECU	Actual, with emulated discrete input	Red Diamond
GCDP	Actual	Red Diamond

*b. Simulated GCDP M1A2 Configuration*

1553 Device	Status	Emulator Appearance (Fig #21)
HEU	Actual	Red Diamond
TEU	Actual	Red Diamond
DID	Actual	Red Diamond
CID	Actual	Red Diamond
DECU	Actual, with emulated discrete input	Red Diamond
GCDP	Emulated	Green Diamond

## 2. IMA FIT Capability

To verify goals for the IMA FIT capability, only one remote terminal configuration within the M1A2 SIL was needed. The complete M1A2 terminal status for the test configuration is shown below.

1553 Device	Status	Emulator Appearance
HEU	Actual	Red Diamond
TEU	Actual	Red Diamond
DID	Actual	Red Diamond
CID	Actual	Red Diamond
DECU	Actual, with emulated discrete input	Red Diamond
GCDP	Actual	Red Diamond

## 3. IMA TP Manual Hyperlinking

To verify goals for the IMA FIT capability, the same remote terminal configuration used for the FIT capability was also used for the IMA TP manual hyperlinking.

### C. TEST PROCEDURE

#### 1. IMA BIT Capability

With the M1A2 SIL running in the configuration described in Section V.B.1.a, a known set of BIT faults were injected via the DID emulation. In Sub-address #30 the following faults were set (see Figure 20 for the DID emulation):

- Data word 5, bit 5 (Graphics Board Dynamic RAM)
- Data word 6, bit 15 (Display Monitor)
- Data word 4, bit 1 (Graphics Board)
- Data word 3, bit 0 (DID Selftest Status)

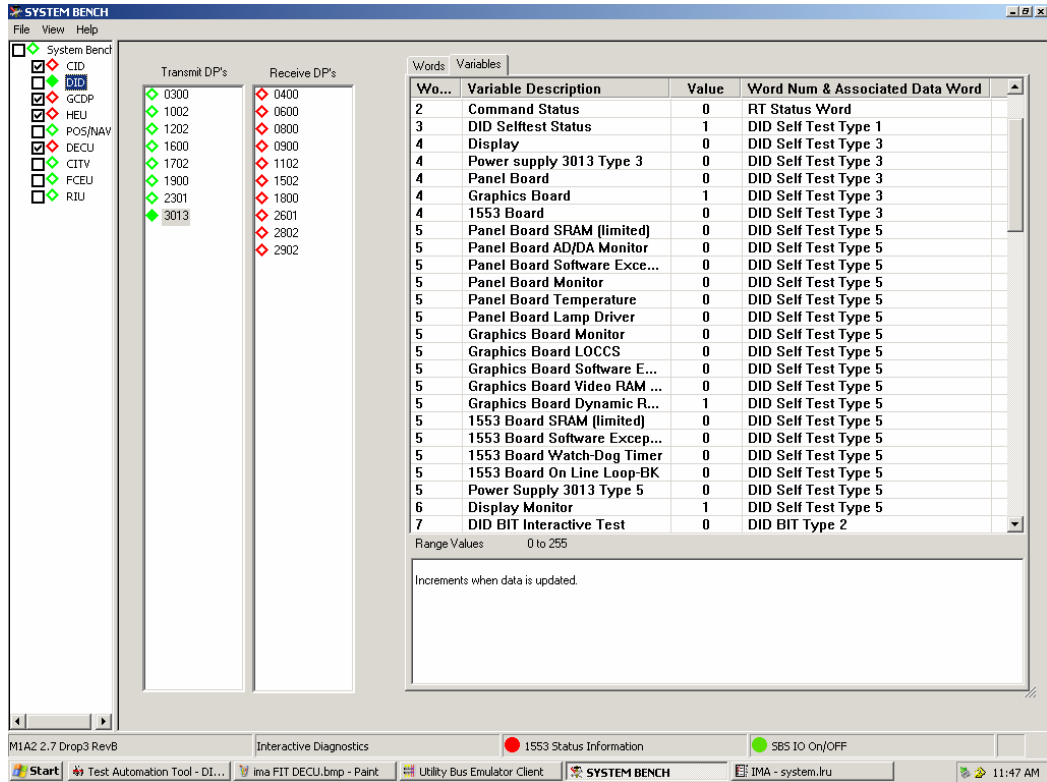

Figure 20. Injected BIT Faults For DID

With the controlled data inputs injected above, the IMA is launched on a PC that is also connected to the 1553 system data bus:

- a. Verify on the IMA system.lru window that DID terminal is flagged red.
- b. Verify on the IMA did.lru sub-system window that DID tactical display and tactical graphics board are flagged red.
- c. Verify on the IMA system.lru window that, upon clicking the large “Error Message Window”, that all injected DID faults can be viewed. These appear in a circular scroll list on successive mouse clicks.

With the controlled data inputs removed:

- d. Verify on the IMA system.lru window that DID terminal is no longer flagged red.
- e. Verify on the IMA did.lru sub-system window that DID tactical display and tactical graphics board are no longer flagged red.
- f. Verify on the IMA system.lru window that, upon clicking the large “Error Message Window”, that no DID faults are viewed.

Repeat the procedure above with a known set of BIT faults injected via the GCDP emulation. In Sub-address #30 the following faults were set (see Figure 21 for the GCDP emulation):

- Data word 4, bit 0 (1553 Board Type 3)
- Data word 3, bit 0 (GCDP Selftest Type 1)
- Data word 5, bit 0 (1553 Board Watch-Dog Timer)
- Data word 6, bit 15 (1553 Board On Line Loop-Back)

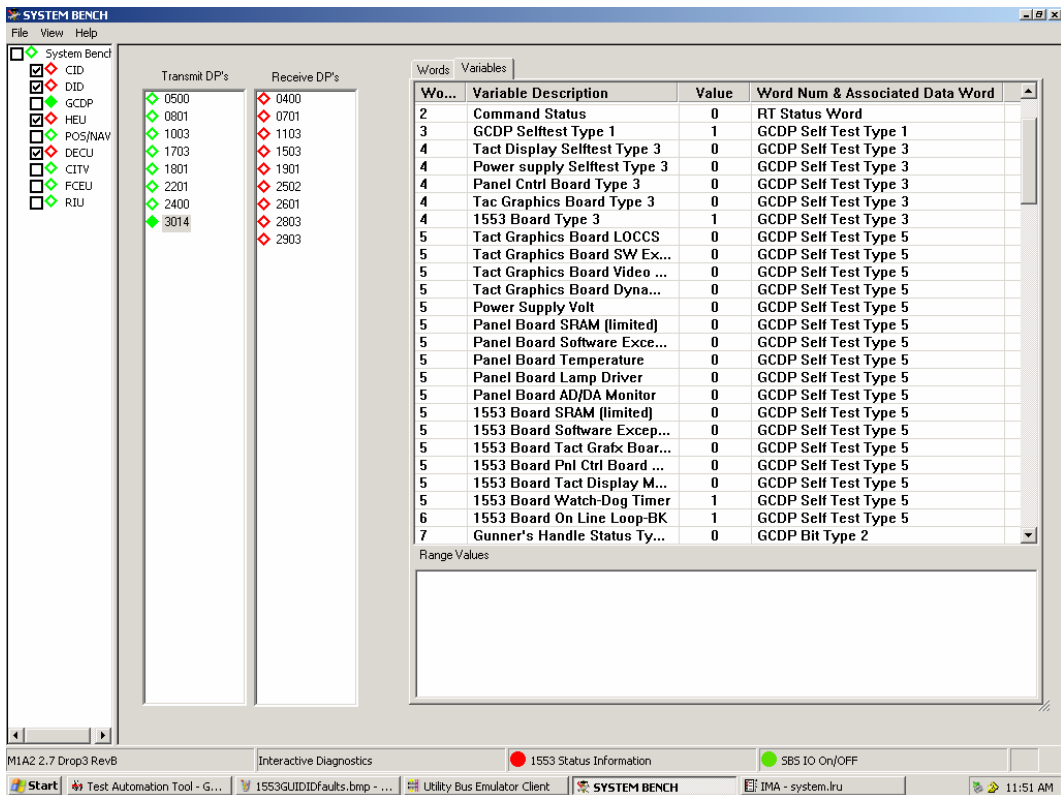

Figure 21. Injected BIT Faults For GCDP

With the controlled data inputs injected above:

- Verify on the IMA system.lru window that GCDP terminal is flagged red.
- Verify on the IMA gcdp.lru sub-system window that GCDP 1553 board is flagged red.

- c. Verify on the IMA system.lru window that, upon clicking the large “Error Message Window”, that all injected GCDP faults can be viewed. These appear in a circular scroll list on successive mouse clicks.

With the controlled data inputs removed:

- d. Verify on the IMA system.lru window that GCDP terminal is no longer flagged red.
- e. Verify on the IMA gcdp.lru sub-system window that GCDP 1553 board is no longer flagged red.
- f. Verify on the IMA system.lru window that, upon clicking the large “Error Message Window”, that no GCDP faults are viewed.

## 2. IMA FIT Capability

IMA FIT reporting capabilities were tested using a third test environment where DECU faults could be injected. With the M1A2 SIL running in the configuration as described in Section V.B.2, DECU emulated engine data for the DECU data was set to conflict within the system. Hence, the system recognizes a faulty DECU. The system BIT check was run and as expected the DECU appeared as NOGO after the system BIT, refer to Figure 22. Faulty equipment must exist for the M1A2 system to output TP reference codes during system FIT execution. IMA FIT testing could now be performed.



Figure 22. DECU BIT Fail on CID

The next step was to execute a system FIT check. Before initiating the FIT check with the system hardware, the IMA FIT action was initiated. This kicks off the IMA FIT monitoring of Sub-address 30. This extra IMA logic was necessary because system FIT data is only valid during FIT execution. Automotive (DECU) related TP codes were expected as a result of the FIT check.

- a. Verify the IMA FIT capture logic retrieves TP code information.
- b. Verify that on the IMA FIT Output Window that captured TP codes match that reported by the real system hardware.

### **3. IMA TP Manual Hypertext Linking**

To evaluate the IMA hypertext linking capability, the same FIT report TP codes captured during the DECU FIT reporting validation would be used, TP codes 272, 280, and 285. The test method was to have three different subjects navigate through the hard copy TP manuals and flag all the pages referenced in each TP tree. The time it took for all flags to be put in place were captured to be analyzed. Flagged pages would also be compared to the IMA hypertext link to ensure accuracy. The test criteria below was used for the test:

- Three people navigating DECU TP codes in time
- Flag all page references for the TP navigation (known path)
- Collect the end times when all flags are set

## **D. TEST RESULTS/REPORTING**

The following table summarized all IMA test results. PC screen captures of the IMA were saved during testing. These screen captures illustrate the observed results.

## 1. IMA BIT Capability Test Results

IMA Test Results Table

Capability	Criteria Reference	Expected result	Observed Result	Comment
IMA BIT reporting	V.C.1.a-DID	DID terminal is flagged red on IMA system.lru window when faults injected	As Expected	See Figure 23
IMA BIT reporting	V.C.1.b-DID	DID tactical display and tactical graphics board are flagged red on IMA did.lru sub-system window when faults injected	As Expected	See Figure 24
IMA BIT reporting	V.C.1.c-DID	When injected, all DID faults can be viewed by clicking the large "Error Message Window" on the system.lru window.	As Expected	See Figure 25
IMA BIT reporting	V.C.1.d-DID	After clearing DID faults, DID terminal is no longer flagged red on IMA system.lru window.	Red DID flag not cleared. IMA restart was required to clear flag on the high level system.lru window.	No code to reset/populate the internal GUI RT flag array for the active window.
IMA BIT reporting	V.C.1.e-DID	After clearing DID faults, DID tactical display and tactical graphics board are no longer flagged red on IMA did.lru sub-system window.	As Expected	None
IMA BIT reporting	V.C.1.f-DID	After clearing DID faults, no DID faults are viewed upon clicking the large "Error Message Window" on the system.lru window.	All DID faults were visible in the same circular scroll loop.	No code to reset/clear the RT fault array stored for system.lru window.
IMA BIT reporting	V.C.1.a-GCDP	GCDP terminal is flagged red on IMA system.lru window when faults injected	As Expected	See Figure 26

Capability	Criteria Reference	Expected result	Observed Result	Comment
IMA BIT reporting	V.C.1.b-GCDP	GCDP 1553 board is flagged red on IMA gcdp.lru sub-system window when faults injected	As Expected	See Figure 27
IMA BIT reporting	V.C.1.c-GCDP	When injected, all GCDP faults can be viewed by clicking the large “Error Message Window” on the system.lru window.	As Expected	See Figure 28
IMA BIT reporting	V.C.1.d-GCDP	After clearing GCDP faults, GCDP terminal is no longer flagged red on IMA system.lru window.	Red GCDP flag not cleared. IMA restart was required to clear flag on the high level system.lru window.	No code to reset/populate the internal GUI RT flag array for the active window.
IMA BIT reporting	V.C.1.e-GCDP	After clearing GCDP faults, GCDP 1553 board is no longer flagged red on IMA gcdp.lru sub-system window.	As Expected	None
IMA BIT reporting	V.C.1.f-GCDP	After clearing GCDP faults, no GCDP faults are viewed upon clicking the large “Error Message Window” on the system.lru window.	All GCDP faults were visible in the same circular scroll loop.	No code to reset/clear the RT fault array stored for system.lru window.



## 2. IMA FIT Capability Test Results

Capability	Criteria Reference	Expected result	Observed Result	Comment
IMA FIT reporting	V.C.2.a	TP code information is captured during system FIT execution.	As Expected	TP codes are populated in the FIT Output Window. See Figure 29
IMA FIT reporting	V.C.2.b	Captured TP codes match that reported by the real system hardware	IMA reports TP codes 272, 280, 285, and 605. The M1A2 system report for the Automotive sub-system is illustrated in Figure 25. TP codes are 272, 280, and 285. Note that IMA also reports TP code 605, this is valid because the system also reported an additional cable disconnect TP code, 605, under the M1A2 communications sub-system.	See Figures 29 and 30. Both IMA and the system report TP codes 272, 280, 285, and 605.
IMA Hypertext linking	V.C.3	IMA page references are accurate and IMA hypertext linking is a faster, reliable method for TP manual navigation.	See section 3 below.	See section 3 below.

### 3. IMA Hypertext Linking Test Results/Reporting

Unfortunately, the test subjects that were used were staff engineers; actual vehicle maintainers were unavailable for the test. The engineers were familiar with the manuals and understood the criteria of the test.

Each of the engineers was given one of the TP codes to traverse a specified path. Engineer 1 had the NO path, Engineer 2 had the YES path and Engineer 3 used the IMA with combination of YES and NO decision paths. All of TP codes had an equal number decision steps to traverse to ensure a fair test. The results are shown below.

	TP 272 Manual	TP 280 Manual	TP 285 IMA
ENG 1	6 Min 32 Sec		
ENG 2		6 Min 56 Sec	
ENG 3			20 Sec

This by no means a scientific sample of data but it does suggest that the hyperlinked TMs are more maneuverable than the paper manuals. Whether the maintainers would have performed better than the engineers is speculative at this time.

### 4. Problem with System Buffer Reset

We found a design flaw in the IMA at this part of the test. The system buffer could not be reset. So to run successive tests we would have to reboot the IMA system each time. This will be addressed in the next version of the software.

Low-level BIT fault reporting is not visible to the M1A2 system displays. An external 1553 bus monitor was connected on the 1553 bus to allow monitoring of the Sub-address #30 fault data words for each 1553 terminal (shown in Figure 22 and Figure 23).

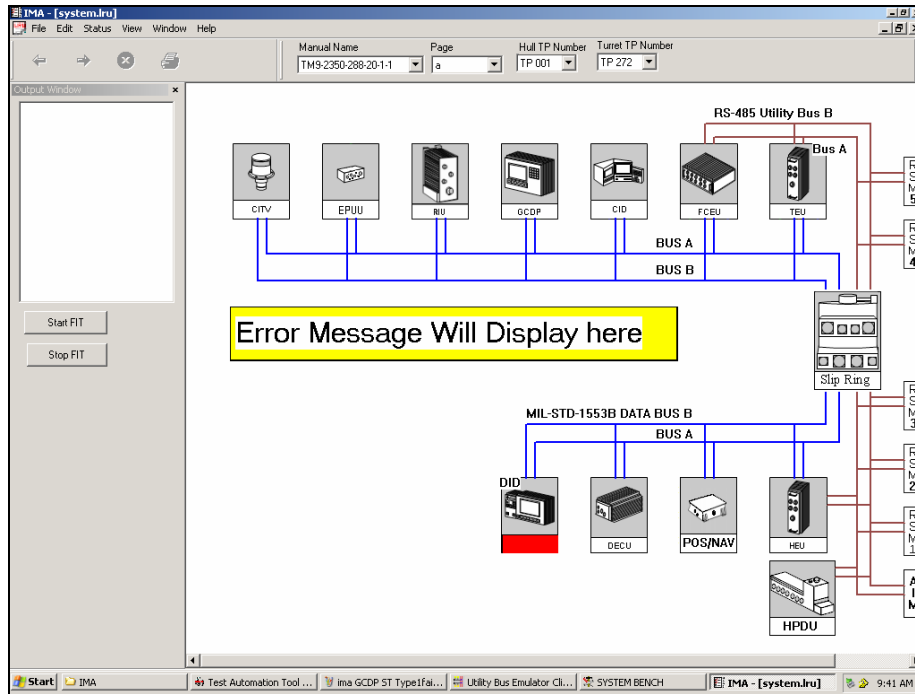

Figure 23. DID BIT Results on IMA

Fault in this message were compared to the faults reported via the IMA for validation (shown in Figure 24 and Figure 25 below).

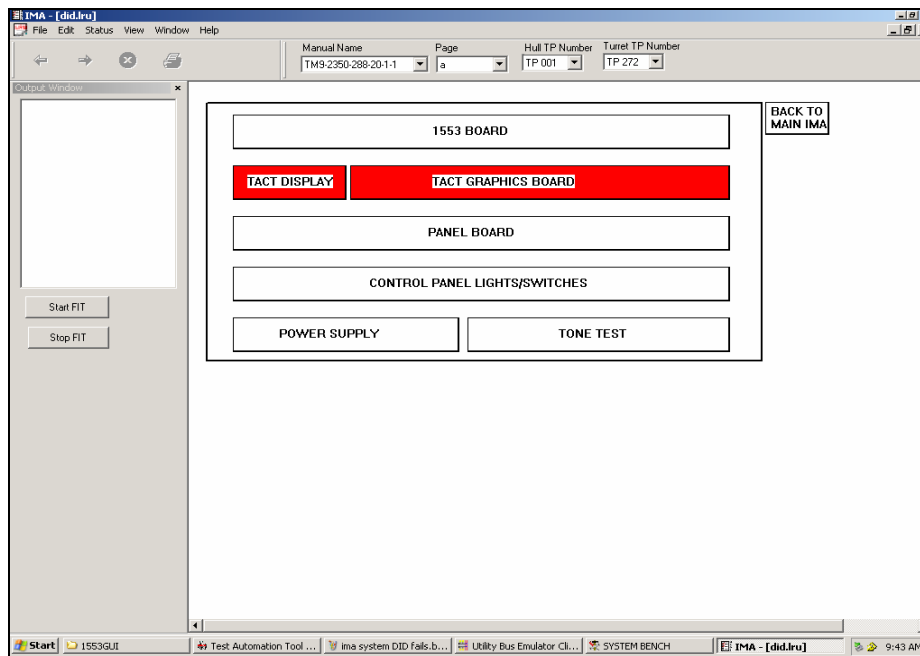

Figure 24. DID BIT Sub-system Results on IMA

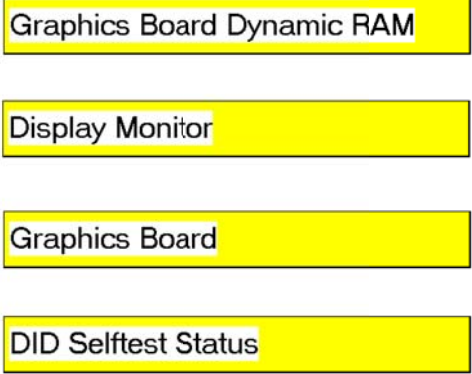

Figure 25. DID BIT Reports from IMA

In addition, IMA had identified the specific board failure in each fault injected LRU (shown in Figure 26 and Figure 27) below.

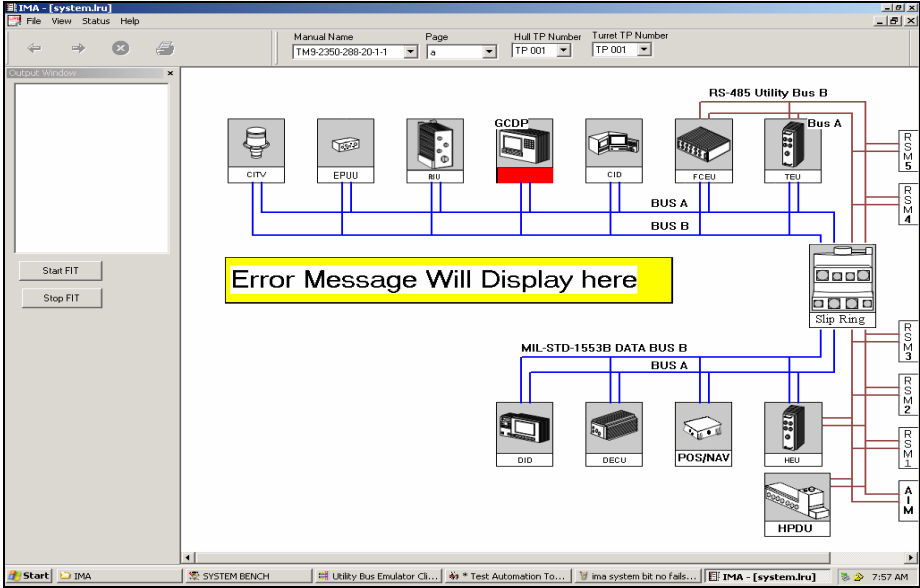

Figure 26. GCDP BIT Results on IMA

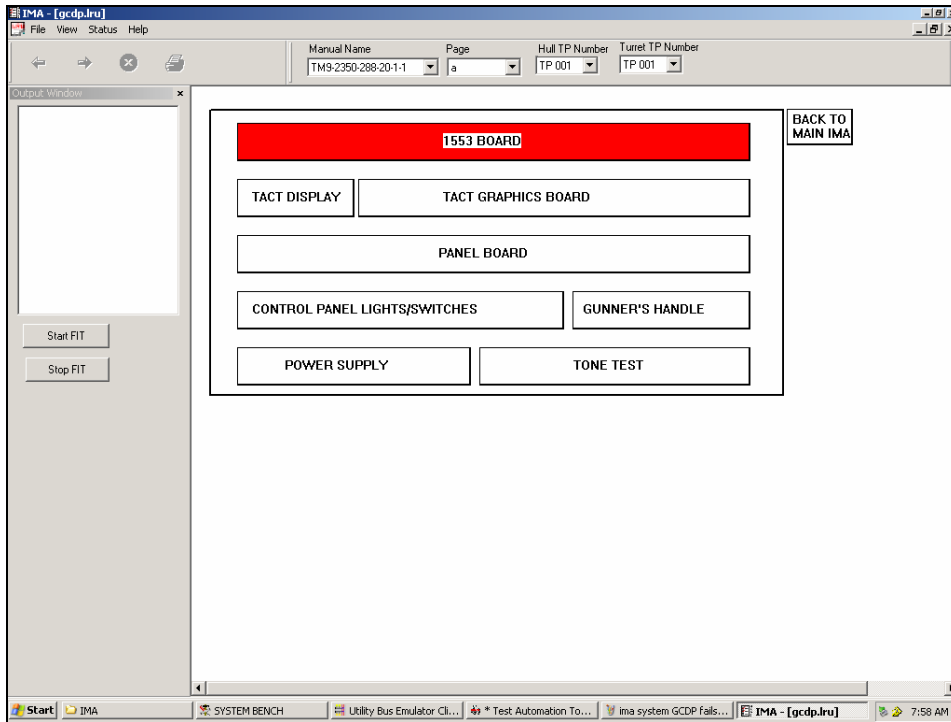

Figure 27. GCDP BIT Sub-system Results on IMA

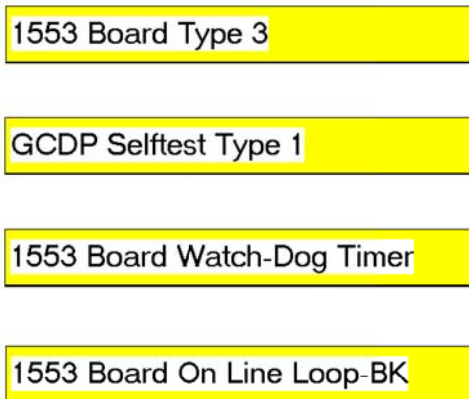

Figure 28. GCDP BIT Reports from IMA

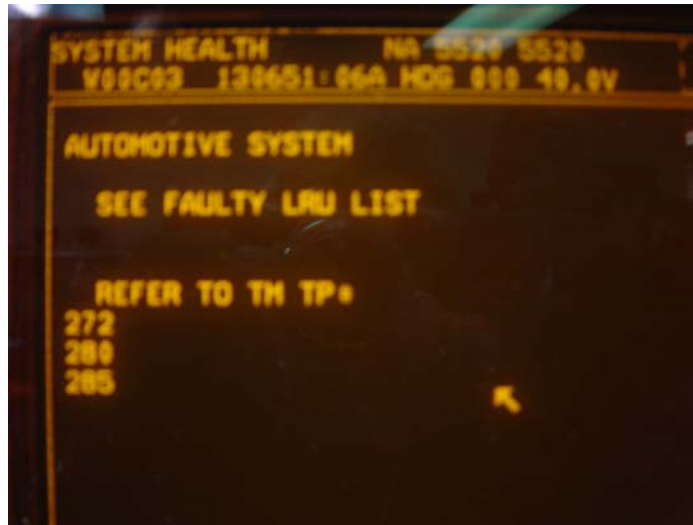

Figure 29. DECU FIT Results on CID

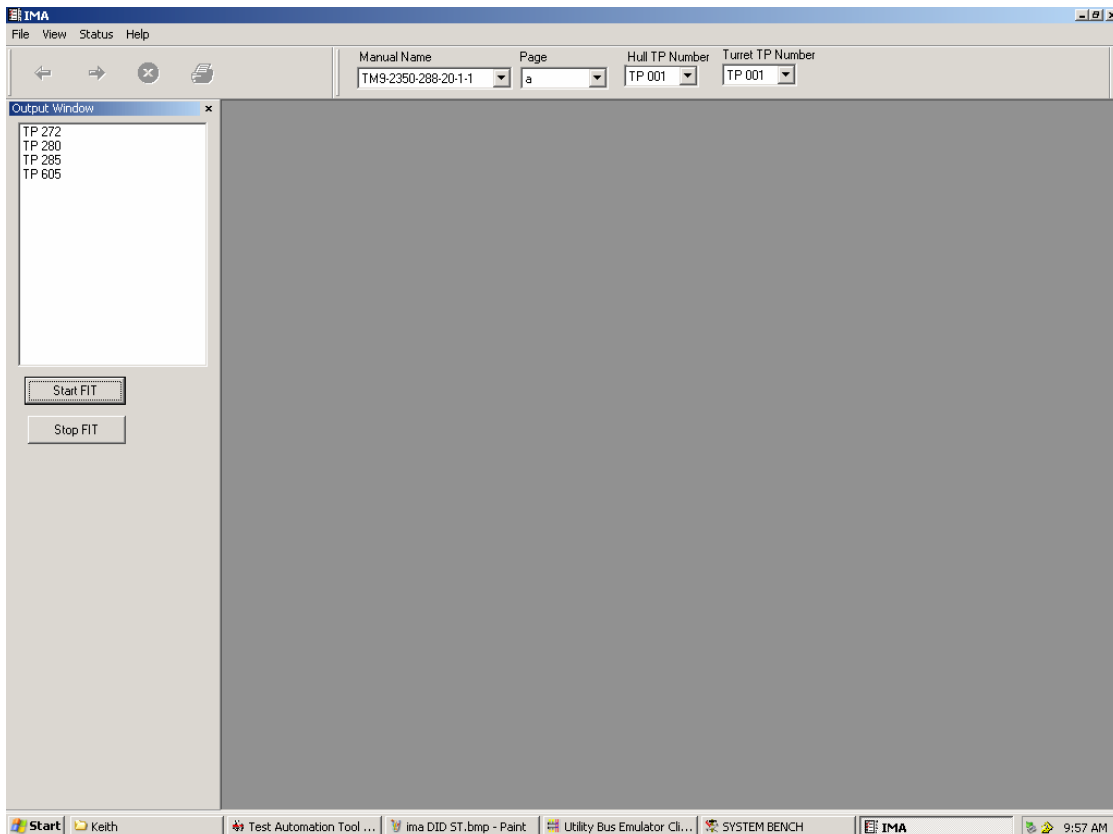

Figure 30. DECU IMA FIT Results

## **E. TP MANUAL USAGE**

To evaluate hardcopy manual usage, the same FIT report TP codes captured during the DECU FIT reporting validation were used. The test criteria below were used for the test:

- Three people navigating DECU TP codes in time
- Flag all page references for the TP navigation (known path)
- Collect the end times when all flags are set

Unfortunately, the test subjects were staff engineers; actual vehicle maintainers were unavailable for the test. The engineers were familiar with the manuals and understood the criteria of the test (refer to Section V.A item 3 and Section V.C item 3).

## VI. CONCLUSION

In designing and building the IMA, we attempted to provide the end user (the maintainer in our case), with a diagnostic tool that went beyond what was provided by the Technical Manuals (TMs). By utilizing the M1A2 diagnostics capability in conjunction with an enhanced electronic version of the TMs, the IMA would arm the maintainer with a new arsenal of tools to increase his capability to reduce time in diagnosing vehicles. The key thrust in the development of the IMA was to reduce or eliminate technical manuals in print, reducing possibly of mix-ups, lost pages, and reducing update costs. One of the key elements in the design was not to increase the logistics burden to the program manager, therefore, the use of the SPORT software downloader was chosen, as it was already part of the inventory.

### A. LESSONS LEARNED

The lesson learned during development of the IMA was requirements creep. Throughout the requirement and design phase of this thesis project, management of, if you will, “the bells and whistles” became paramount. We wanted to provide the maintainer as many tools as possible while keeping in mind the scale of project. With this said, we had to tone down what to include in this phase of development. The end result is a set of advanced tools that presents the user/maintainer greater flexibility and insight into 1553 data bus message passing and diagnostics.

Having the actual maintainers perform the diagnostic tests from start to finish would have been the ideal test environment to prove paper versus computer. Due to the war effort, finding qualified maintainers to participate in a master’s thesis research was impossible.

It is the author’s sincere hope that further research time will be given to pursue and convince the program management office that the IMA is a useful and timesaving device.



## **B. FOLLOW ON WORK**

### **1. Pre-Planned Product Improvement**

Once the IMA has proven its capabilities and value to the Army maintenance and support activities we can further investigate and exploit the technology that is available from commercial industry to further enhance IMA capabilities. Further areas of interest would be prognostics, Maintenance Knowledge Database (MKD) and automated preventive maintenance activities. COTS software packages such as Prognostic Framework will be investigated and leveraged to enhance system capabilities. Adding prognostic capability will preempt component failures and improve the vehicle's readiness. Implementing a MKD will provide various types of information such as vehicle repair history and access to the fleet vehicle repairs that are similar to the diagnosed problem. The MKD will also provide repairs with tips and methods from other Army technicians. It will also have the capability to order the parts needed for the repair and list the parts that were ordered in the past to fix similar problems. The automated preventative maintenance will schedule, maintain, and track a vehicle's usage through system logs and by the types of mission the vehicles are being sent on.

### **2. Removing the System Buffer Reset Problem**

Further development of the IMA must include reset for the system buffer. As we encountered during the testing phase when injecting the faults and running BIT and FIT tests the resulting TP codes were in the system buffer with no way to clear them. The only method was to re-boot the IMA system and start process again.

## LIST OF REFERENCES

GDLS S/SDD (2003). System/Segment Design Document For The Abrams Systems Enhancement Program (US) Tank - Fault Management, General Dynamics Land Systems Division.

Larman, Craig. (1997) *Applying UML and Patterns: an introduction to object-oriented analysis and design*. Upper Saddle River, NJ., Prentice Hall

Tank Automotive Research & Development Engineering Center (TARDEC) (2002) SWLCP. Software Life Cycle Plan.

Tank Automotive Research & Development Engineering Center (TARDEC) (1998) M1A2 Abrams Post Deployment Software Support (PDSS) Training. M1A2 PDSS Bench Environment.

THIS PAGE INTENTIONALLY LEFT BLANK

## INITIAL DISTRIBUTION LIST

1. Defense Technical Information Center  
Ft. Belvoir, Virginia
2. Dudley Knox Library  
Naval Postgraduate School  
Monterey, California
3. Dr. Man-Tak Shing  
Naval Postgraduate School  
Monterey, California
4. Dr. Peter Denning  
Naval Postgraduate School  
Monterey, California
5. Magid Athnasios  
United States Army RDECOM  
AMSRD-TAR-R / MS-265  
Warren, Michigan
6. Russ Menko  
United States Army RDECOM  
AMSRD-TAR-R / MS-265  
Warren, Michigan
7. Michael Smith  
United States Army RDECOM  
AMSRD-TAR-R / MS-265  
Warren, Michigan
8. Keith Shockley  
United States Army RDECOM  
AMSRD-TAR-R / MS-265  
Warren, Michigan