

# Automatic Feature Recognition of Chamfer and Fillet for Turning Part Model by Volume Decomposition Method

Ahmad Faiz Zubair<sup>1</sup>

Mohd Salman Abu Mansor<sup>2\*</sup>

<sup>1,2</sup> School of Mechanical Engineering, Engineering  
Campus, Universiti Sains Malaysia,  
14300 Nibong Tebal, Pulau Pinang, Malaysia.

\* Corresponding author: [mesalman@usm.my](mailto:mesalman@usm.my)

## ABSTRACT

*The present paper illustrates the development of generative feature recognition of cylindrical part model that emphasize on recognition of chamfer and fillet. Without automation, manual work on recognizing these features are tedious and time consuming. Chamfers were recognized by conical surface while constant radius fillets on concave and convex edges were recognized by circular faces and edges. Cylindrical stock model, sub-delta volume for finishing (SDVF) of feature's recognized and sub-delta volume for roughing of the part model were generated. The resulted volume decomposition in term of delta volume were then compared with manual calculation of feature's delta volume to achieve the differential error. Two examples of part model were tested and the results show less than zero differential error. These prove that the algorithm is able to recognize cylindrical part model chamfers and fillets feature.*

**Keywords:** CAPP, Automatic Feature Recognition, Chamfer, Fillet, Sub Delta Volume.

## 1.0 Introduction

Aiming in increasing quality and reducing lead time and cost has led to vast interest in Computer Aided Process Planning (CAPP) researches and studies. In other word, implementation of CAPP will enhance productivity

improvement in production. As one major component in CAPP is feature extraction and recognitions, automatic feature recognition method is one of the best way of doing it. Volume decomposition of feature's being recognized will be the generated to replicate the exact material removal volume. As different features will used different tools to do the machining, it is important to recognize all the features separately. This includes fillet and chamfer on cylindrical part model. Many designs implemented these features to enhance part function. As for that, recognition of fillet and chamfer cannot be neglected. Akin to previous works of recognition features of cylindrical part model, offsetting technique will be adopted in this study. Although there are many types of fillet, this study will only recognized constant size of fillet for concave and convex edges. Sub-delta volume for finishing (SDVF) and sub-delta volume for Roughing (SDVR) will be generated as the last result of the recognition. Chamfers and fillets volumes will be compared to manual calculation of volume to get the differential error percentage.

### **1.1 Related Work**

More than five decades ago, research and works on CAPP started to pursue interest of many researchers. CAPP methods including features based, knowledge based, artificial neural networks, genetic algorithms (GA), fuzzy set theory and fuzzy logic, Petri nets (PN), agent, Internet, standard for the exchange of product data (STEP)-compliant method, and functional blocks (FB) method/technologies were been discussed [1]–[3]. Among all these methods, feature based technology is among the most popular. This study will be a blend of automatic feature recognition in term of volume decomposition, rule based and knowledge based method. Some of applications done by previous researchers including application on precision manufacturing [4], parallel machining [5] in case of more than one machine involved, sheet metal machining [6], [7] and also prismatic micro part [8].

As this study will focus on turning part, previous research turning part as well as mill-turn parts were also been studied and compared. Matthew in [9] doing an automatic reasoning to differentiate milling and turning operation in mill-turn parts. This method is interesting as the two machining features is differentiate by generating a revolve feature from its datum and both turnable and non-turnable features were generated by Boolean operations. Moreover, Shiqiao and Jami [10] had done further complex features including interacting features and non-interacting features in mill-turn part.

Volume decomposition method were also been done in past researches. Kataraki and Abu Mansor [11] had applied volume decomposition method in their research, although cylindrical shape for bosses were covered, different approach had been used in this study. Moreover, Bok and Abu Mansor [12] had used volume decomposition for regular and freeform milling part model. This paper will focus on symmetrical cylinder part model that are reliable for

turning machining feature recognitions and the extension of authors works [13]. The extension includes the recognition of chamfer and fillets in the symmetrical cylinder part model of turning part.

## 2.0 Algorithm Framework

The algorithm was constructed in Microsoft Visual Studio 2010 Professional Edition version 10.0.40219.1 SP1Rel with Microsoft.NET Framework version 4.6.01055 SP1Rel platform and ACIS solid modeller version R25 SP1 platform. The process flow is shown in Fig. 1. CAD part model input is as Standard ACIS Text (.SAT) file

The developed algorithm will first validate the input part model. This validation includes part model type and volumetric. Only .SAT part model and volumetric part model will be process, if it is not in these conditions algorithm will hold false. Next to generate SDVF of recognized faces, all faces of the part model will be identified. Its have to be mentioned other faces SDVF generation were explained from previous work of authors in [13]. To focus on chamfer and fillet, first chamfer feature will be recognized. Faces with geometrical shape of cone, will be checked as chamfer features probability. This conical faces is then been analyzed of its leg distance and angle. If it is  $45^0$  or  $30^0$  angle then it will be marked as chamfer. A database of the features will be generated and SDVF of these marked features will be generated. Next, fillet SDVF will be generated by recognizing circular edge and generating a new profile. This will be explained in section 3.2. Next, SDVR bodies will be generated which will be explained in section 3.3.2. Volumes of all bodies generated will be calculated and comparison with manual calculation of volumes will be addressed.

Figure 1:

## 3.0 Technical Definition

This section provides technical definition of cylindrical part model, stock model, the sub delta volumes invloved and chamfer and fillet features that are recognized. This study is the enhancement of previous work done by reearchers [11]–[13] which enhance the features been recognized. Stock model, sub delta volume of square type for milling machining had been clearly define previously [11], [12]. This study will focus on cylindrical stock model that include different method on generating SDVF of the recognized features. Part model will be divided into two section in half. This is to eliminate errors that will happen to the algorithm especially co-edge errors and topological errors.

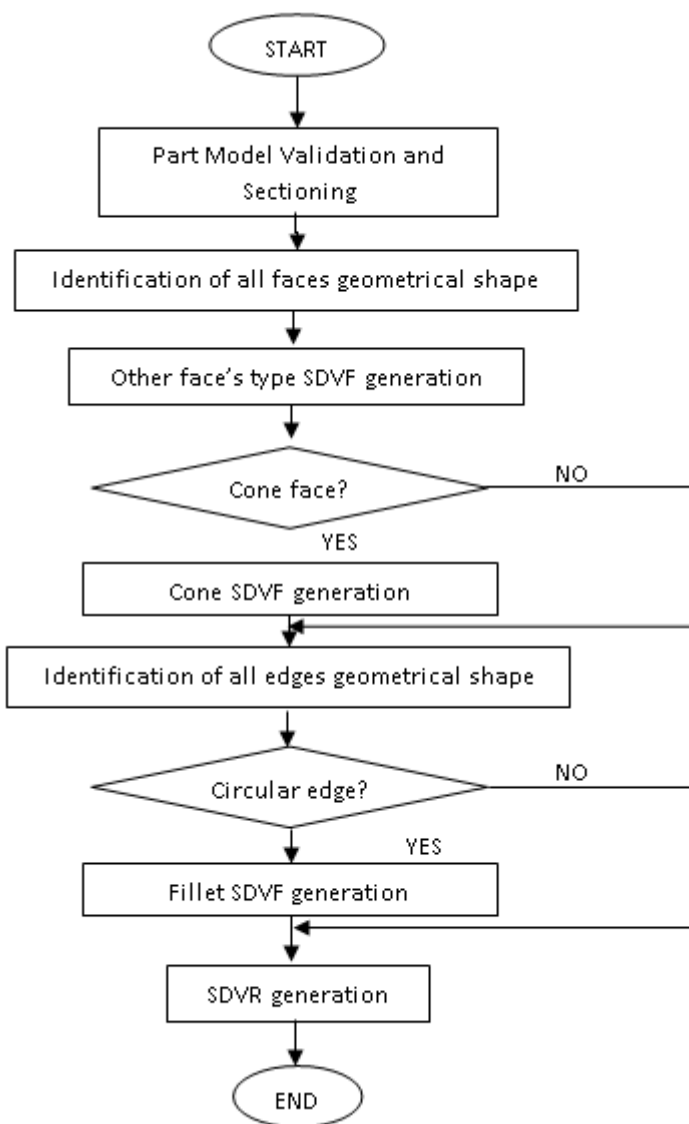

Figure 1: Algorithm process flow

### 3.1 Chamfer

Chamfers for cylindrical part are common for variety of reasons. These chamfers are machined to be bevelled edges. One of the common reasons to have chamfers is to remove burrs. Chamfered edge around a hole is called countersink, but it is only used with smaller hole. More often the term chamfer is applied for larger holes and not small holes. It also express as a straight edge that has been bevelled. Moreover, end of cylinder been chamfered in many cases for the ease of assembly. Figure 2 shows some example of chamfer. Leg distance is measure aside chamfer. If a chamfer is  $45^\circ$ , leg distance will be the same on both sides. If the chamfer angles other than  $45^\circ$ , a leg distance must be specified. In order to recognize chamfer in the cylindrical part model, topological structure of the chamfer has to be identified. Figure 3 shows chamfer feature on the part model and its SDVF generation. To recognize chamfer, developed algorithm need to detect it as conical features. After the detection, algorithm will continue generate SDVF of the recognize features. With the recognition, a list of the same features will be generated and it will be recalled at the end of the algorithm to calculate the volume and further generation of SDVR.

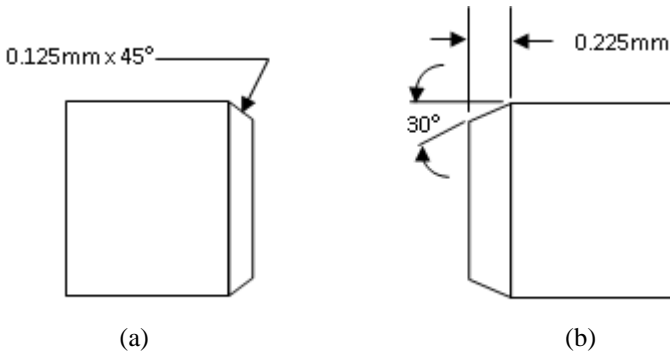

Figure 2: Type of chamfer. (a)  $45^\circ$  chamfer and (b)  $30^\circ$  chamfer.

#### 3.1.1 Chamfering and Tapering

Chamfering and tapering machining are different by the tools that are used. Chamfer machining normally using chamfer tools which depend on the chamfer angle. Chamfering length will be according to work piece diameter and normally smaller. While tapering used different tools depend on the work piece shape. It can be form tool, swivel compound rest tool. Length of tapering will be longer depending on the shape.

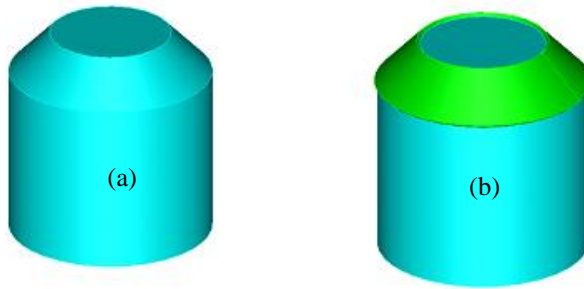

Figure 3: Chamfer feature and its SDVF

### 3.2 Fillet

In contrast of chamfer, fillet is a round type of edge on a part model. Fillet is measured by the radius of the round on the edges. There are many type of fillet including constant radius fillet, multiple radius fillet, round corner fillet, setback fillet, variable radius fillet, face fillet and full round fillet [14]. As for turning machining, only constant radius fillet will be recognized. The developed algorithm will recognize fillet on both concave and convex edges. Figure 4 shows the example of fillet feature from SolidWorks software and type of concave and convex edges.

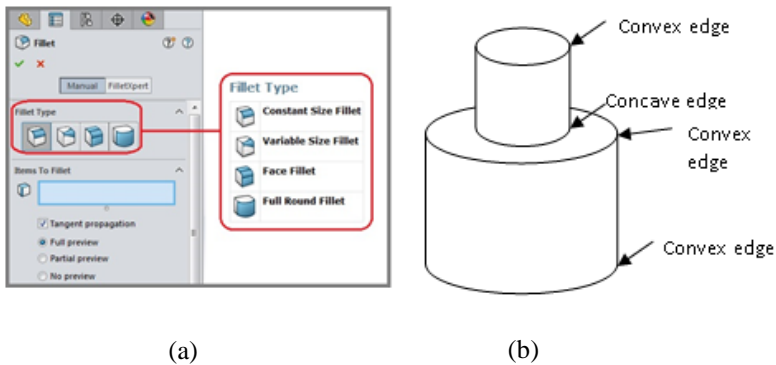

Figure 4: (a) Type of fillet [14] and (b) type of edges.

In order to recognize fillet feature, face of the fillet need to be recognize. As it is a full round fillet with constant radius, it will be recognized from the circular edges of the divided part model. From the edges a similar edge is copied and offset to form a profile which later being revolve to form a SDVF of fillet. Figure 4 shows the recognition and generation of constant radius fillet. Cylinder face can be differentiate by the developed algorithm and the list of

recognize cylindrical faces is then generated. The generated SDVF has no issue on uniform thickness as offsetting approach is applied.

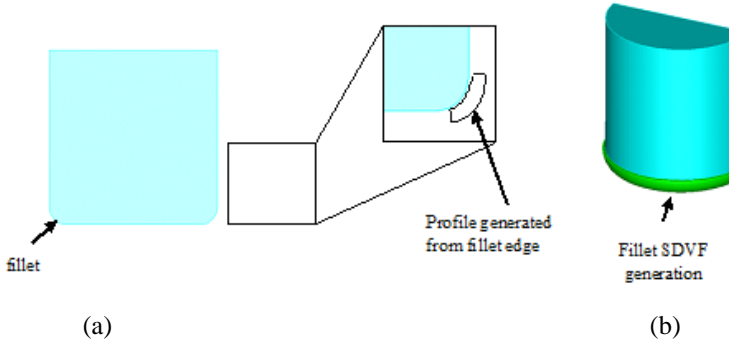

Figure 4: Fillet recognition and SDVF generation on convex edge.

### 3.3 Sub Delta Volume

Sub delta volume of recognized features are the volume generated by the algorithm featuring the recognized features. In order to suit machining processes of roughing and finishing, SDVR and SDVF generated. This will consider thickness of  $i, j$  and  $k$  from user's input. By generating this volumes, the exact material to be removed from the stock model can be simulated. With these information process planning of the part model can be generated. Volumes generated will be compared to the manual volume based on CAD software volume. It is shown in Eqn. (1). These equation is been used by previous researchers [11]–[13] as well.

$$\Delta V = (V_{alg} - V_{fCAD}) \times 100 \div V_{CAD} \quad (1)$$

$$V_{fCAD} = V_{f'CAD} - V_{CAD}$$

$\Delta V$  = Volume different

$V_{alg}$  = Feature's volume generated from Algorithm

$V_{fCAD}$  = Feature's volume generated from CAD software

$V_{f'CAD}$  = Overall volume of part model with feature

$V_{CAD}$  = CAD model volume without feature.

### 3.3.1 Sub Delta Volume for Finishing (SDVF)

Finishing process will be done after roughing process. Range of 0.75mm-2mm were the thickness of the finishing layer with depth of cut recommended 0.25mm by using High Speed Steel (HSS) cutting tool [15]. To generate these volume, face of features to be recognized is copied and lofted body is generated. To ensure uniform thickness of generated bodies, offsetting approach is been used. Figure 5 shows the concept of SDVF generation. To remove overlapping and gap between SDVF, SDVF will be filled and intersection of the SDVF bodies will be removed by using Boolean operations of subtraction between the bodies.

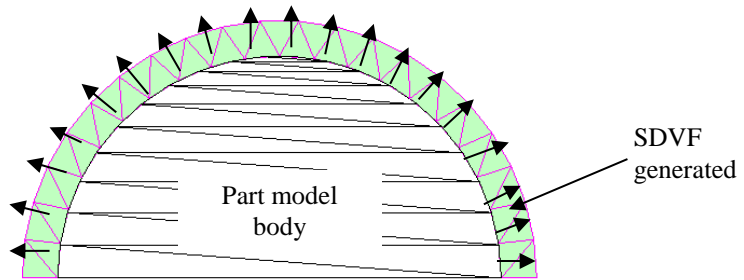

Figure 5: SDVF body generation in facet top view.

### 3.3.2 Sub Delta Volume for Roughing (SDVR)

Roughing process will be done before finishing process. Thickness of the roughing will be in range of 2.5mm-20mm. Therefore user will be asked to enter the thickness. In order to get the SDVR body, boolean operation will be done. Body of SDVF and part model body will be extracted from the stock model. This operation will generate exact shape of SDVR. Figure 6 shows the assembly of SDVR in facet view. SDVR bodies will be generated in four sections which are in top, bottom, left and right section. This is for the ease of recognition to prevent topological error in the algorithm.



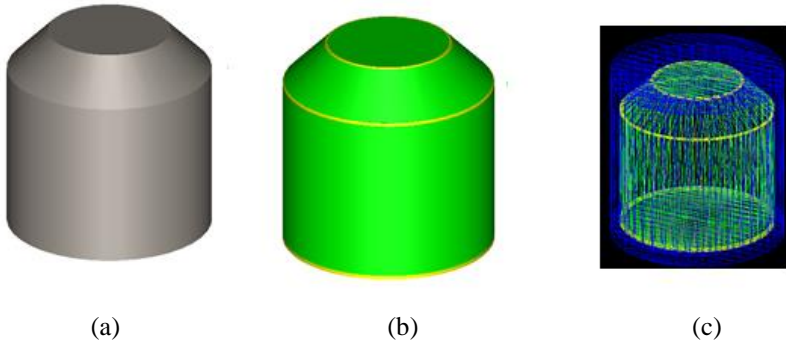

Figure 6: SDVR of the part model. (a) Part model, (b) complete SDVF of part model and (c) assembly of part model, SDVF and SDVR in facet view.

#### 4.0 Validation and Implementation of Algorithm

Several softwares are being used to develop the algorithm. These include CAD software to model generate part model and export it as .SAT file format and an open source C++ language CAD modeller software to develop algorithm in order to facilitate the recognition of features.

##### 4.1 Example 1

A cylinder part model with both fillet and chamfer was executed using the proposed approach in the developed algorithm. From user input, finishing thickness,  $t$  is 1mm and the boundary thickness for each direction,  $i$ ,  $j$  and  $k$  are 4mm each. Figure 7 shows the part model dimensioning. The part model has two fillets with 10mm radius each and a 45° chamfer of 7 mm length.

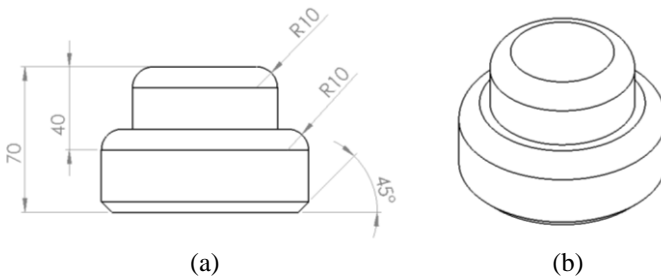

Figure 7: Example 1 part model. (a) the front view and (b) the isometric view.

Figure 8 shows the recognition of fillets and chamfers on the part model and the complete SDVF of the part model. In order to validate the ODV generated, it has to be compare with manual calculation and it is shown in term on percentage errors  $\Delta V$ . From the calculation,  $\Delta V$  produced in comparing with manual calculation is almost zero. These errors show very significant result in generating the ODV. Thus the generation can be accepted.

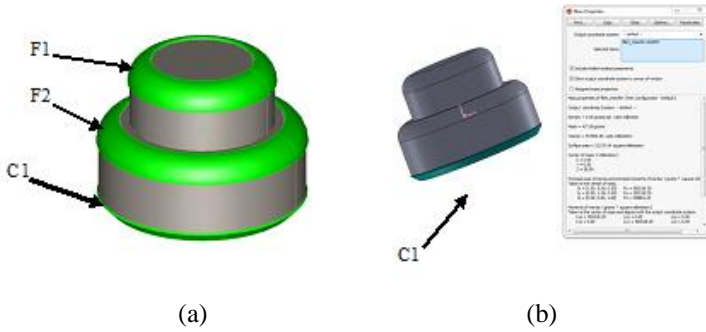

Figure 8: Recognition of fillet and chamfer. (a) SDVF of fillets and chamfer and (b) manual chamfer generating from SolidWorks.

Table 1: Volume of fillets and chamfer SDVF generation

Feature	Volume from CAD ( $V_{fCAD}$ )	Volume from Algorithm ( $V_{alg}$ )	% Different ( $\Delta V$ )
F1	1642.005	1642.01	0.000003
F2	2419.24	2419.5	0.00011
C1	1063.04	1603.04	0

#### 4.2 Example 2

Another example was used to validate the developed algorithm. This example is taken from real part of piston intake valve which has different dimensions of chamfer and fillet. Figure 9 shows the dimensioning of the second example. This example contains two fillets in two type of edges with dimensions of 10mm on concave edge and 2mm radius on convex edge, while two 45° chamfer with different leg length. Finishing thickness of 1mm and 5mm roughing thickness is being used as the inputs.

Figure 10 shows the recognition of fillets and chamfers on the part model in half section view and the complete SDVF of the part model. The

develop algorithm will develop a table that shows all the features been identified.

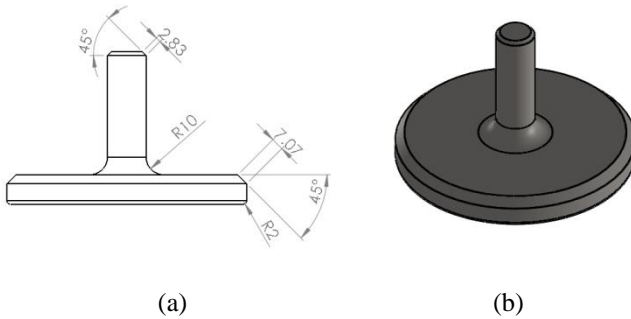

Figure 9: Example 2 part model. (a) the front view and (b) the isometric view.

Errors  $\Delta V$  produced in comparing with manual calculation are almost zero. This shows repeated significant result from the previous example. Thus confirming the algorithm will works well on recognizing the features.

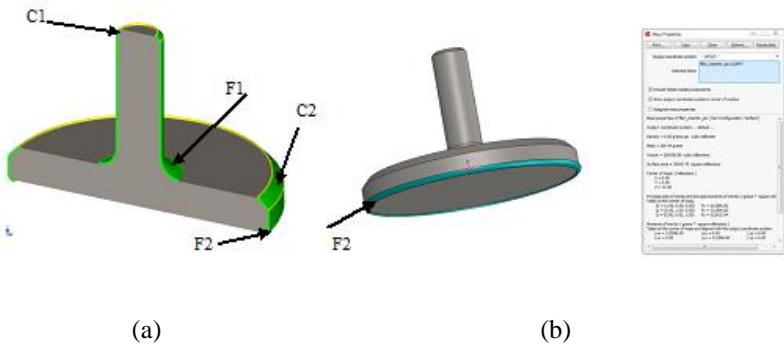

Figure 10: Recognition of fillet and chamfer. (a) SDVF of fillets and chamfer in half section and (b) manual fillet generating from SolidWorks.

## 5.0 Conclusions

This paper exemplifies approach on feature recognition of cylinder part model which emphasizes on chamfer and fillet. Chamfers and fillets were successfully been recognized with all other features. The offsetting technique

similar from previous work is continuing produce consistent body thickness of SDVF bodies thus produce efficient results. Verification of two part model examples show substantial sum of errors in recognizing wanted features.

Table 1: Volume of fillets and chamfer SDVF generation

Feature	Volume from CAD ( $V_{fCAD}$ )	Volume from Algorithm ( $V_{alg}$ )	% Different ( $\Delta V$ )
C1	90.375	90.372	0.000033
F1	692.12	692.094	0.00004
C2	1445.185	1445.19	0.000003
F2	824.305	824.302	0.000004

## Acknowledgements

This research is supported by Universiti Sains Malaysia under the Research University Grant (No: 814247) and Universiti Sains Malaysia IPS conference fund. The first author also would like to thank the support of the Universiti Teknologi MARA for staff sponsorship.

## References

- [1] Y. Yusof and K. Latif, "Survey on computer-aided process planning," *Int. J. Adv. Manuf. Technol.*, vol. 75, no. 1–4, pp. 77–89, 2014.
- [2] X. Xu, L. H. Wang, and S. T. Newman, "Computer-aided process planning: a critical review of recent developments and future trends," *Int. J. Comput. Integr. Manuf.*, vol. 24, no. 1, pp. 1–31, 2011.
- [3] H. B. Marri, a. Gunasekaran, and R. J. Grieve, "Computer-aided process planning: A state of art," *Int. J. Adv. Manuf. Technol.*, vol. 14, no. 4, pp. 261–268, 1998.
- [4] M. Bagge, "Process planning for precision manufacturing," 2014.
- [5] J. B. Levin and D. Dutta, "Computer-aided process planning for parallel machines," *J. Manuf. Syst.*, vol. 11, no. 2, pp. 79–92, 1992.
- [6] T. R. Kannan and M. S. Shunmugam, "Processing of 3D sheet metal components in STEP AP-203 format . Part II: feature reasoning system," vol. 7543, no. December, 2016.
- [7] R. K. Gupta and B. Gurumoorthy, "Classification, representation, and automatic extraction of deformation features in sheet metal parts," *CAD Comput. Aided Des.*, vol. 45, no. 11, 2013.
- [8] S. K. S.P Leo Kumar, J. Jerald, "CAPP for prismatic micro part.pdf,"

- Int. J. Comput. Integr. Manuf.*, vol. 28, no. 10, pp. 1046–1062, 2014.
- [9] M. I. Campbell, “Automatic Reasoning for Defining Lathe Operations for Mill-Turn Parts : A Tolerance Based Approach,” *J. Mech. Des.*, vol. 136, no. December 2014, pp. 1–10, 2016.
- [10] L. ; Shiqiao and J. J. Shah, “Recognition of User-Defined Turning Features for Mill / Turn,” *J. Comput. Inf. Sci. Eng.*, vol. 7, no. September 2007, pp. 225–235, 2007.
- [11] P. S. Kataraki and M. S. Abu Mansor, “Auto-recognition and generation of material removal volume for regular form surface and its volumetric features using volume decomposition method,” *Int. J. Adv. Manuf. Technol.*, 2016.
- [12] A. Y. Bok and M. Abu Mansor, “Generative regular-freeform surface recognition for generating material removal volume from stock model,” *Comput. Ind. Eng.*, vol. 64, no. 1, pp. 162–178, 2013.
- [13] A. F. Zubair and M. S. Abu Mansor, “Cylindrical axis detection and part model orientation for generating sub delta volume using feature based method,” *ARPJ J. Eng. Appl. Sci.*, vol. 11, no. 22, pp. 13415–13419, 2016.
- [14] T. Richard, “An Advanced Breakdown of the SOLIDWORKS Fillet Feature Tool,” 2016. [Online]. Available: <http://www.engineersrule.com/advanced-breakdown-solidworks-fillet-featuretool/>.
- [15] S. Kalpakjian, *Manufacturing engineering and technology*. Pearson, 2006.