

Aus der Klinik für Neurologie mit experimenteller Neurologie
der Medizinischen Fakultät Charité – Universitätsmedizin Berlin

DISSERTATION

The effect of subthalamic deep brain stimulation on motor
learning in Parkinson's disease

zur Erlangung des akademischen Grades
Doctor medicinae (Dr. med.)

vorgelegt der Medizinischen Fakultät
Charité – Universitätsmedizin Berlin

von

Ana Luísa de Almeida Marcelino

aus Lissabon

Datum der Promotion: 18. Dezember 2020

Table of contents

Table of contents	2
Index of abbreviations	3
Abstract - English	3
Zusammenfassung - Deutsch.....	4
Synopsis	6
1. Current state of research	6
2. Aim of this study.....	13
3. Methods	14
4. Results	19
5. Discussion.....	24
Bibliography	29
Statutory Declaration	35
Detailed declaration of own contribution to the top-journal publication	36
Extract from the Journal Summary List (ISI Web of KnowledgeSM)	38
Printed copy of the publication	39
Curriculum vitae.....	49
Complete list of publications.....	51
Acknowledgements	52

Index of abbreviations

DBS	deep brain stimulation
fMRI	functional magnetic resonance imaging
GPe	external globus pallidus
GPI	internal globus pallidus
M1	primary motor cortex
PD	Parkinson's disease
SNC	substantia nigra pars compacta
SNr	substantia nigra pars reticulata
STN	subthalamic nucleus
STN-DBS	deep brain stimulation of the subthalamic nucleus

Abstract - English

Deep brain stimulation (DBS) of the subthalamic nucleus is an effective and adjustable treatment for Parkinson's disease patients with (early) motor complications and has been shown to elicit changes in motor and non-motor cortico-basal ganglia circuits through modulation of distributed neural networks. Recent findings on subcortical basal ganglia - cerebellar anatomy have revealed projections from the subthalamic nucleus to cerebellar hemispheres, which might be modulated by subthalamic DBS. Both the basal ganglia and the cerebellum are known to be involved in motor learning and Parkinson's disease.

This study aimed at investigating the effect of subthalamic DBS on motor learning in Parkinson's disease (PD) and characterizing underlying neural networks. To this end, 20 Parkinson's disease patients undergoing subthalamic DBS and 20 age-matched healthy controls performed a visuomotor task. Motor learning was assessed as reduction in movement times from beginning to end of task for each group. DBS electrodes were localized and projected to a publicly available normative connectome (1000 healthy subjects) and a connectivity map for DBS induced improvement in motor learning was calculated. Region of interest analysis was performed to assess the role of connectivity to motor cortex (M1) and cerebellar hemispheres in DBS induced learning. Permutation tests and multiple regressions were conducted for the main statistical analyses; for significant regression models and correlations leave one out cross validation (LOOCV) was performed.

Motor learning was impaired in Parkinson's disease patients off DBS comparing with healthy controls (PD off DBS: $12.2 \pm 5.4\%$ from $1311 \pm 160\text{ms}$ to $1089 \pm 118\text{ms}$; mean \pm standard error of mean; healthy controls: $33.48 \pm 3.6\%$ from $729 \pm 63\text{ms}$ to $473 \pm 42\text{ms}$; off DBS vs. healthy controls $P=0.002$). STN-DBS led to a statistically significant improvement in motor learning (PD on DBS: $27.7 \pm 6.1\%$ from $940 \pm 120\text{ms}$ to $615 \pm 84\text{ms}$; on vs. off DBS $P=0.01$). There was no statistically significant difference between patients on DBS and healthy controls ($P=0.4$). DBS induced improvement in motor learning was not correlated with improvement in motor deficits ($R=-0.02$, $P=0.5$). A specific connectivity profile including the right cerebellar hemisphere was associated with improved motor learning through DBS ($R^2=0.33$, $P=0.01$; LOOCV: $R=0.43$, $P=0.028$). Region of interest analysis revealed the ipsilateral cerebellum to be the best predictor of DBS induced motor learning ($R^2=0.34$, $P=0.008$; LOOCV: $R=0.045$, $P=0.02$). Here, connectivity to the STN was higher than to M1, suggesting a putative role of the recently discovered basal ganglia - cerebellar circuit bypassing the cortex.

This study extends current knowledge on motor learning in Parkinson's disease and highlights the notion of network modulation in DBS.

Zusammenfassung - Deutsch

Die Tiefe Hirnstimulation (THS) des Nucleus subthalamicus ist eine effektive Therapiealternative für Patienten mit idiopathischem Parkinson Syndrom (IPS) und (frühen) motorischen Komplikationen, welche zu verschiedenen motorischen und nicht-motorischen Effekten in der Kortex-Basalganglienschleife führt. Es ist lange bekannt, dass die Basalganglien und das Kleinhirn sowohl beim IPS als auch beim motorischen Lernen eine Rolle spielen. Neue anatomische Studien zeigten eine disynaptische subkortikale Verbindung zwischen den Nucleus subthalamicus und den Kleinhirnhemisphären mit bisher unklarer funktioneller Bedeutung.

Die vorliegende Studie untersucht den Effekt subthalamischer THS auf motorisches Lernen beim idiopathischen Parkinson Syndrom mit dem Ziel, zugrundeliegende neuronale Netzwerke zu charakterisieren. Hierfür führten 20 Patienten mit IPS unter THS und 20 altersgepaarte gesunde Probanden eine visuomotorische Reaktionszeitaufgabe durch. Motorisches Lernen wurde als Verbesserung der Bewegungszeiten durch Wiederholung der Aufgabe definiert. THS Elektroden wurden lokalisiert und auf ein öffentlich verfügbares normatives funktionelles MRT Konnektom projiziert (1000 gesunde

Probanden). Das optimale Konnektivitätsprofil für THS induziertes motorisches Lernen wurde berechnet. Zusätzlich wurde eine Konnektivitätsanalyse durchgeführt, um die Rolle der Verbindung von aktiven THS Kontakten zum motorischen Kortex und zu den Kleinhirnhemisphären für THS induziertes Lernen zu untersuchen. Die statistische Auswertung der Hauptergebnisse erfolgte durch Monte Carlo Permutation und multiple Regressionen; statistisch signifikante Regressionsmodelle und Korrelationen wurden mittels der „Leave one out“ Methode kreuzvalidiert.

Patienten mit IPS und ausgeschalteter THS zeigten ein signifikant beeinträchtigtes motorisches Lernen im Vergleich zu gesunden Kontrollen (IPS mit THS OFF: $12.2 \pm 5.4\%$, von $1311 \pm 160\text{ms}$ auf $1089 \pm 118\text{ms}$; gesunde Kontrollen: $33.48 \pm 3.6\%$, von $729 \pm 63\text{ms}$ auf $473 \pm 42\text{ms}$; $P=0.002$). Die subthalamische THS führte zu einer statistisch signifikanten Verbesserung des motorischen Lernens in Patienten mit IPS (IPS mit THS ON: $27.7 \pm 6.1\%$, von $940 \pm 120\text{ms}$ auf $615 \pm 84\text{ms}$; $P=0.01$). Es ergab sich kein signifikanter Unterschied zwischen Patienten mit eingeschalteter THS und gesunden Kontrollen ($P=0.4$). THS induziertes motorisches Lernen korrelierte nicht mit Linderung motorischer Symptome ($R=-0.02$, $P=0.5$). Es konnte ein spezifisches fMRT Konnektivitätsprofil von den aktiven THS Kontakten definiert werden, welches prädiktiv für den Effekt der THS auf motorisches Lernen war ($R^2=0.33$, $P=0.01$; LOOCV: $R=0.43$, $P=0.028$). Eine weiterführende Analyse ergab einen gesonderten Einfluss der rechten Kleinhirnhemisphäre als bester Prädiktor für THS induziertes motorisches Lernen ($R^2=0.34$, $P=0.008$; LOOCV: $R=0.045$, $P=0.02$). In diesen Voxels war funktionelle Konnektivität zum Nucleus subthalamicus höher als zum motorischen Kortex, hinweisend auf eine relevante Rolle der beschriebenen direkten Verbindung vom Nucleus subthalamicus zu den Kleinhirnhemisphären.

Diese Studie liefert neue Erkenntnisse über den Zusammenhang von motorischem Lernen und der Neuromodulation motorischer Netzwerke beim idiopathischen Parkinson Syndrom und erweitert das Konzept der Netzwerkmodulation als mechanistisches Modell zur Wirksamkeit der THS.

Synopsis

1. Current state of research

1.1 Parkinson's disease: epidemiology, clinical features and standard treatment

Parkinson's disease (PD) is a motor circuit disorder affecting primarily the basal ganglia (DeLong and Wichmann, 2007). It is the second most prevalent neurodegenerative disorder after Alzheimer's disease and affects 2-3% of the population aged 65 years or older (Poewe *et al.*, 2017). The cardinal clinical signs of Parkinson's disease are bradykinesia combined with either resting tremor, rigidity or both (Postuma *et al.*, 2015). A myriad of other motor (e.g. freezing of gait, postural instability) and non-motor features (depression, dementia, autonomic disorders or sleeping disturbances) can appear in course of disease (Lang and Lozano, 1998). Parkinson's disease usually begins unilaterally and evolves asymmetrically. Depending on the predominant motor symptom observed, it can be divided into akinetic-rigid, tremor-dominant and equivalent subtypes. The diagnosis is made clinically through physical examination showing the classical motor signs, presence of supportive evidence such as good response to dopaminergic treatment or other typical non-motor signs and after exclusion of potential differential diagnoses.

Oral levodopa and dopamine agonists represent the first line treatment for Parkinson's disease and are effective in reducing motor symptoms (Lang and Lozano, 1998; Poewe *et al.*, 2017). However, treatment can be associated with disabling side effects such as nausea, orthostatic hypotension, day-sleepiness or impulse control disorders and long-term complications such as motor fluctuations, levodopa-induced dyskinesia, wearing off and loss of efficacy (Lang and Lozano, 1998). Derived from ablative surgery, deep brain stimulation (DBS) is an adjustable and reversible surgical treatment that has proven highly effective in treatment of Parkinson's disease with (early) motor complications (Deuschl *et al.*, 2006; Schuepbach *et al.*, 2013). The subthalamic nucleus is nowadays the most used DBS target in Parkinson's disease. Clinical trials showed an average reduction in motor signs over 40% as measured through the third part of the Unified Parkinson's Disease Rating Scale (UPDRS-III) and a relevant improvement in patient reported quality of life after subthalamic deep brain stimulation (Deuschl *et al.*, 2006; Schuepbach *et al.*, 2013). Furthermore, studies reported on an average reduction of levodopa equivalent daily dose up to 50% (Deuschl *et al.*, 2006). These improvements were significantly greater than under best medical therapy (Deuschl *et al.*, 2006;

Schuepbach *et al.*, 2013). While the positive outcomes regarding motor symptoms and quality of life have been reproduced consistently (Weaver *et al.*, 2012), non-motor effects of subthalamic DBS are often more heterogeneous (Volkman *et al.*, 2010) and might depend on electrode location (Accolla *et al.*, 2016). Hypomania, impulsivity and cognitive impairment have been reported after subthalamic DBS (Volkman *et al.*, 2010). Even though its mechanism of action is still unknown, recent evidence suggests that DBS evokes specific circuit and network alterations beyond the stimulated target location (Kahan *et al.*, 2014; Neumann *et al.*, 2018).

1.2 Basal ganglia circuits and pathophysiology of Parkinson's disease

The degeneration of dopaminergic neurons in the substantia nigra pars compacta (SNc) and the intracellular accumulation of alpha-synuclein inclusion bodies ("Lewy bodies") are pathological hallmarks of Parkinson's disease (Ehringer and Hornykiewicz, 1960; Forno, 1996). Dopaminergic depletion in Parkinson's disease is associated with pathological firing patterns and imbalance in basal ganglia circuits (Albin *et al.*, 1989; DeLong, 1990; Bergman *et al.*, 1994; Fig. 1). The basal ganglia have traditionally been described as functionally organised in two main pathways: the direct and the indirect pathway (Alexander *et al.*, 1986; Albin *et al.*, 1989; DeLong, 1990). The first has been hypothesized to promote movement (initiation): the striatum projects GABAergic neurons directly to the output nuclei (internal globus pallidus and substantia nigra pars reticulata) and, in turn, their inhibitory effect upon the thalamus is suppressed, which results in an activation of the cortex through glutamatergic projections from the thalamus. The indirect pathway has been proposed to mediate movement inhibition through the external globus pallidus and the subthalamic nucleus (STN) and is thought to be more active in Parkinson's disease (Albin *et al.*, 1989; DeLong, 1990; DeLong and Wichmann, 2007). The hyperdirect pathway represents a more recently described monosynaptic projection from the cortex to the STN (Nambu *et al.*, 2002). Furthermore, there is increasing evidence of cerebellar involvement in Parkinson's disease (Wu and Hallett, 2013). Recently, a disynaptic anatomical connection between the subthalamic nucleus and cerebellar hemispheres through pontine nuclei has been discovered (Bostan *et al.*, 2010). Its functional significance is still not clear, but it may mediate cerebellar contributions to Parkinson's disease (Bostan and Strick, 2018).

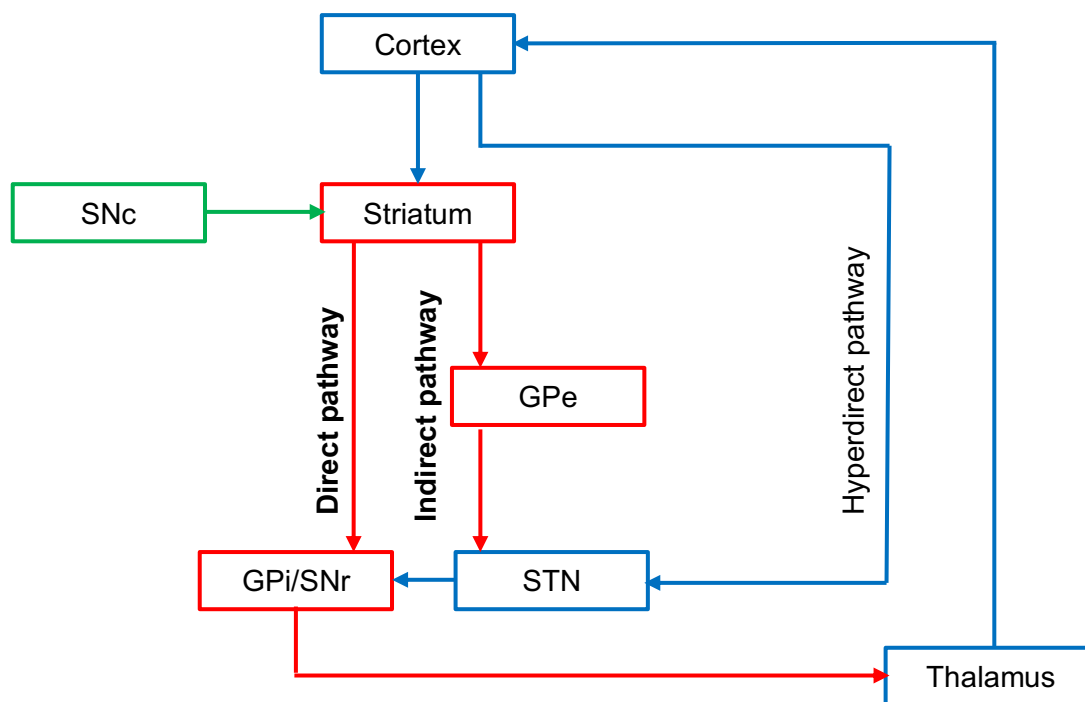

Figure 1: **Simplified scheme of the main basal ganglia circuits.** The direct pathway is thought to facilitate movement, whereas the indirect pathway has been hypothesized to mediate movement inhibition. In Parkinson’s disease, dopaminergic depletion might lead to predominance of the indirect pathway, reflecting in slowness of movement (Alexander *et al.*, 1986; Albin *et al.*, 1989; DeLong and Wichmann, 2007). Glutamatergic, GABAergic and dopaminergic projections are in blue, red and green, respectively.

Abbreviations: SNc = Substantia nigra pars compacta; GPi = Internal globus pallidus; SNr = Substantia nigra pars reticulata; GPe = External globus pallidus; STN = Subthalamic nucleus

1.3 DBS as a research platform to investigate disease and behaviour

Deep brain stimulation allows studying poorly accessible deep brain structures in human patients in context of disease and behaviour. For instance, recording of local field potentials from the subthalamic nucleus through DBS electrodes has demonstrated increased oscillatory activity in the beta band as a potential pathophysiological correlate of Parkinson’s disease that can be suppressed by active stimulation (Kühn *et al.*, 2008). Contributions of DBS research to neural correlates of motor control and decision making would be an analogue example regarding behaviour: Evidence mainly from electrophysiological recordings in animal studies suggests that the STN mediates inhibitory control, integrating information from the cortex through the hyperdirect pathway (Nambu *et al.*, 2002). In human studies with parkinsonian patients, STN-DBS has been

shown to reduce the ability to slow down responses before high-conflict decisions, leading to shorter reaction times and more erroneous responses in decision making tasks (Frank *et al.*, 2007; Green *et al.*, 2013). The STN has been hypothesized to adapt motor output by setting decision thresholds (Herz *et al.*, 2016). A recent study has demonstrated that STN-DBS adjusts decision thresholds through modulation of oscillatory activity in Parkinson's disease (Herz *et al.*, 2018). Non-motor effects of subthalamic DBS may also depend on electrode location, as the subthalamic nucleus is functionally subdivided into motor, limbic and associative territories, which, in turn, are structurally connected to distinct cortical areas (Accolla *et al.*, 2016). For example, stimulation of the limbic STN has been associated with hypomanic behaviour (Volkman *et al.*, 2010; Accolla *et al.*, 2016).

In a previous study combining clinical and behavioural measures, imaging data and computational modelling, we have extended these findings (Neumann *et al.*, 2018). We demonstrated impaired motor control in Parkinson's disease patients undergoing STN-DBS when facing increased cognitive demand (Neumann *et al.*, 2018). Furthermore, we provided evidence that this effect is associated with stimulation of fibres of the hyperdirect pathway. Simulating a lesion of the indirect pathway could predict improvement in movement kinematics, whereas simulating a lesion of the hyperdirect pathway successfully predicted reaction time changes during DBS (Neumann *et al.*, 2018). Figures 2 and 3 show representative behavioural results from the previous study (Neumann *et al.*, 2018).

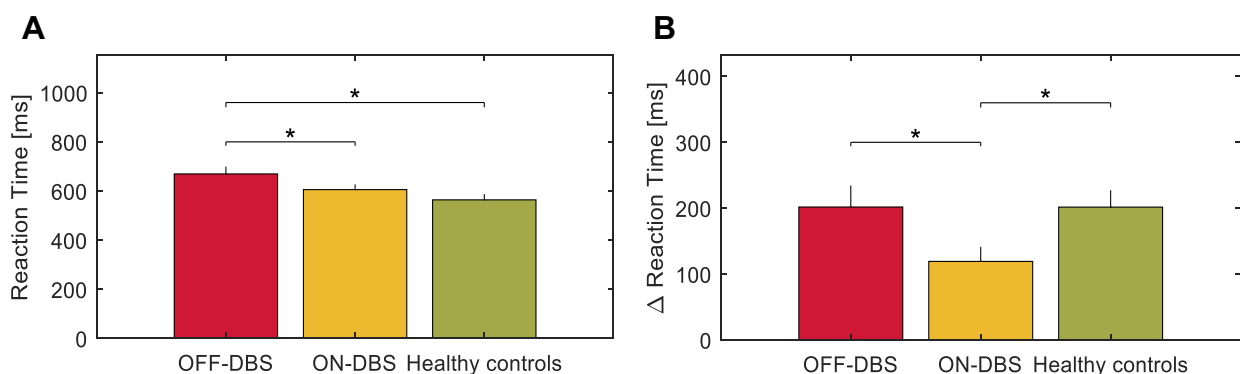

Figure 2: STN-DBS impairs ability to adapt to increased cognitive demand in Parkinson's disease. In a previous study (Neumann *et al.*, 2018), subthalamic DBS led to a statistically significant reduction in reaction times (**A**) (permutation tests, on DBS vs. off DBS $P=0.0022$; on DBS vs. healthy controls $P=0.21$; off DBS vs. healthy controls $P=0.005$) across all averaged trials. However, in trials of higher cognitive demand

(“controlled condition” with inverted pen to cursor mapping in a visuomotor task), STN-DBS impaired the ability to slow down responses in order to adapt motor execution (**B**) (Δ Reaction time = $RT_{\text{controlled}} - RT_{\text{automatic}}$; on DBS vs. off DBS $P=0.004$; on DBS vs. healthy controls $P<0.018$; off DBS vs. healthy controls $P=0.99$). Figure adapted from Neumann *et al.*, 2018.

The STN represents a point of convergence to the indirect and the hyperdirect pathways and modulation of each of these circuits through subthalamic DBS can lead to different motor and non-motor effects (Neumann *et al.*, 2018; Fig. 3). The abovementioned disynaptic projection from the STN to the cerebellum adds complexity to the basal ganglia circuits (Bostan *et al.*, 2010) and is often neglected in favour of simplification in DBS studies. Aberrant cerebellar activity in Parkinson’s disease and its modulation under STN-DBS has been shown in previous studies (Payoux *et al.*, 2004; Asanuma *et al.*, 2006; Wu and Hallett, 2013). To which extent the “short-cut” STN-cerebellar connection contributes to these findings remains to be elucidated.

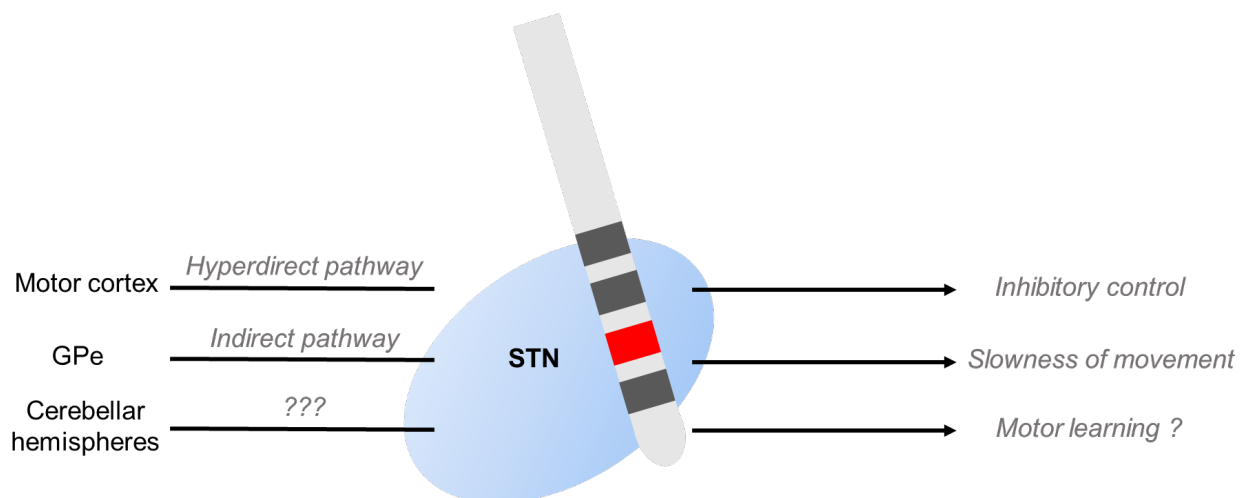

Figure 3: **Schematic illustration on the segregation of basal ganglia pathways modulated by subthalamic DBS.** A DBS electrode with four contacts (the second from bottom is active - in red) is placed in the STN (in blue). Input from different pathways to the STN is represented on the left side, behavioural output under subthalamic stimulation on the right side. Improvement in motor performance might be achieved through stimulation of the indirect pathway (Neumann *et al.*, 2018), whereas stimulation of the hyperdirect pathway in Parkinson’s disease has been proposed to modulate more cognitive aspects of movement control (Nambu *et al.*, 2002; Frank *et al.*, 2007; Neumann

et al., 2018). The role of the projection from cerebellar hemispheres to the STN has not been cleared yet (Bostan and Strick, 2018).

All in all, deep brain stimulation represents a window to deep brain structures such as the basal ganglia and gives insight into (patho-)physiological processes that can be studied through behavioural tasks on and off stimulation and complemented by neuroimaging, computational modelling and other tools.

1.4 Motor Learning and Parkinson's disease

Motor learning is a broad term that describes changes or improvements in motor performance induced by practice as assessed through a defined parameter of interest (Shmuelof and Krakauer, 2011). It encompasses learning a complex skill such as lacing shoes, or learning to tip a simple number sequence as in a PIN code - motor skill learning - as well as learning how to adapt movement to a changing environment - motor adaptation.

Until now, motor skill learning has mostly been assessed through serial reaction time tasks as motor sequence learning. Impairment in motor sequence learning performance in primates after reversible striatal pharmacological inactivation (Miyachi *et al.*, 1997) and in humans after pallidal lesioning (Brown *et al.*, 2003) as well as basal ganglia activation in functional neuroimaging studies (Lehericy *et al.*, 2005) indicate an important role of the basal ganglia in motor skill learning. Motor adaptation has been studied mostly by assessing error rates in paradigms where an external disturbance is introduced such as a force field or a visuomotor rotation. Motor adaptation requires compensation for sensory prediction errors and is impaired in cerebellar disease (Weiner *et al.*, 1983; Bastian, 2006).

In an fMRI study on healthy subjects, early phases of short-term visuomotor skill learning were associated with increased activation of prefrontal, sensorimotor and parietal cortices, as well as caudate nucleus and ipsilateral cerebellum (Floyer-Lea and Matthews, 2004). Activation in these areas decreased in later phases of learning, giving place to increased activity in subcortical motor regions such as the dentate nucleus, the thalamus and putamen (Floyer-Lea and Matthews, 2004). Within the basal ganglia, a shift in activation from ventral associative striato-pallidal regions in early learning phases to more dorsal sensorimotor regions during later phases of learning was associated with automaticity in a motor sequence task (Lehericy *et al.*, 2005). This transition not only

globally from a cortical to a subcortical level but also within the basal ganglia from anterior/associative to posterior/sensorimotor regions may reflect the need for conscious processes while acquiring a motor skill, contrasting with the less attention needed in phases of automaticity/consolidation of motor learning. The orchestration of different brain regions during different modalities and stages of learning adds complexity to the analysis and interpretation of motor learning paradigms.

In Parkinson's disease, impaired ability to learn has been demonstrated for early phases of motor sequence learning and tasks that involve explicit attentional processes (Marinelli *et al.*, 2017). Imaging studies suggest that patients with Parkinson's disease rely on similar neuroanatomical substrates for learning as healthy subjects, however, activation is stronger and further adjacent territories might be activated as shown in PET-studies (Catalan *et al.*, 1999; Nakamura *et al.*, 2001; Wu *et al.*, 2010). It is important to bear in mind that evidence on motor learning in Parkinson's disease is heterogeneous as it depends on specific factors such as disease stage, cognitive status and dopaminergic-treatment. Differential effects of dopamine replacement therapy in motor learning in Parkinson's disease might be explained by "overdosing" of not (yet) affected brain areas involved in motor learning (Gotham *et al.*, 1988).

One study has shown subthalamic DBS induced improvement in motor sequence learning in parkinsonian patients, but not after levodopa infusion (Mure *et al.*, 2012). Here, the DBS effect was associated with increase in a learning-specific network activity, involving the right lateral cerebellum, the parahippocampal gyrus, left dorsal premotor and inferior parietal regions (Mure *et al.*, 2012).

Thus, in contrary to decision making and inhibitory control, there is little evidence on motor learning in Parkinson's disease and studies on the role of subthalamic DBS are even scarcer. More than that, the relevance of modulating subcortical basal ganglia cerebellar interactions through DBS for motor learning remains to be explored.

2. Aim of this study

The present study aimed at elucidating the effect of subthalamic DBS on motor learning in Parkinson's disease and investigating the underlying neural networks. Here, 20 Parkinson's disease patients undergoing STN-DBS and 20 age-matched healthy controls were instructed to perform reaching movements in a visuomotor task and short-term improvement in movement execution was analysed as a reflection of motor learning. Furthermore, functional connectivity patterns from DBS active contacts to a resting state functional network were assessed and associated with DBS induced changes in motor learning.

The following hypotheses were tested:

- 1) Motor learning in Parkinson's disease patients off DBS is impaired comparing to age-matched healthy controls.
- 2) Activation of subthalamic deep brain stimulation restores impaired motor learning in Parkinson's disease patients.
- 3) Specific connectivity profiles from active contact location to the rest of the brain explain DBS induced changes in motor learning.

In the following sections, the methods applied for testing these hypotheses will be described in detail as well as the most important new results. Relevant clinical aspects and scientific issues derived from this study will be discussed.

3. Methods

3.1 Participants and visuomotor task

A detailed description of clinical characteristics of all participants and visuomotor task set up has been provided in Neumann *et al.*, 2018 and de Almeida Marcelino *et al.*, 2019 as both studies analysed the same cohort and behavioural paradigm (see Table 1 of de Almeida Marcelino *et al.*, 2019). Patients were recruited from the movement disorders department of the “Campus Virchow Klinikum” at Charité – University Medicine Berlin throughout the year of 2015. All patients were under stable and individually prescribed medication and had individually adjusted stimulation parameters for best clinical motor effect (Neumann *et al.*, 2018). All Parkinson’s disease patients were clinically examined on and off DBS using the third part of the Unified Parkinson’s Disease Rating Scale (UPDRS-III) to 1) confirm the efficacy of DBS on motor sign alleviation and 2) allow comparison between behavioural results and motor sign alleviation. A summary of participants’ characteristics can be found in Table 1. Parkinsonian patients of tremor-dominant subtype were not included in this study as to avoid interference of tremulous movement execution with behavioural results (Neumann *et al.*, 2018). All patients participated with informed consent. The study was approved by the local ethics committee and carried out in accordance with the Declaration of Helsinki and abided by the rules of “good scientific practice” (“Gute wissenschaftliche Praxis”) of the Charité University Medicine Berlin.

Table 1: **Summarized participants’ characteristics.** UPDRS-III = third part of the Unified Parkinson’s Rating scale, LEDD = levodopa equivalent daily dose; mean \pm standard error of mean given when appropriate.

	PD patients with STN-DBS	Healthy controls
Participants	20 (2f)	20 (3f)
Age	62.6 \pm 1.5 years	63.2 \pm 1.7 years
Disease duration	14 \pm 1 years	-
UPDRS-III ON/OFF	11.2 \pm 1.2 / 28.9 \pm 2.5 pts.	-
LEDD	612.6 \pm 113.6 mg	-

Participants were instructed to operate a cursor on a computer display to reach a target circle by moving a digitizer pen on a tablet (Intuos pro, Wacom Europe GmbH Krefeld,

Germany). A schematic illustration of one complete trial is depicted in Figure 4. Participants were asked to perform as fast and accurate as possible. Only the first 30 trials in this condition were analysed. Trials with inverted pen to cursor mapping as described in Neumann et al. 2018 were not included in this study.

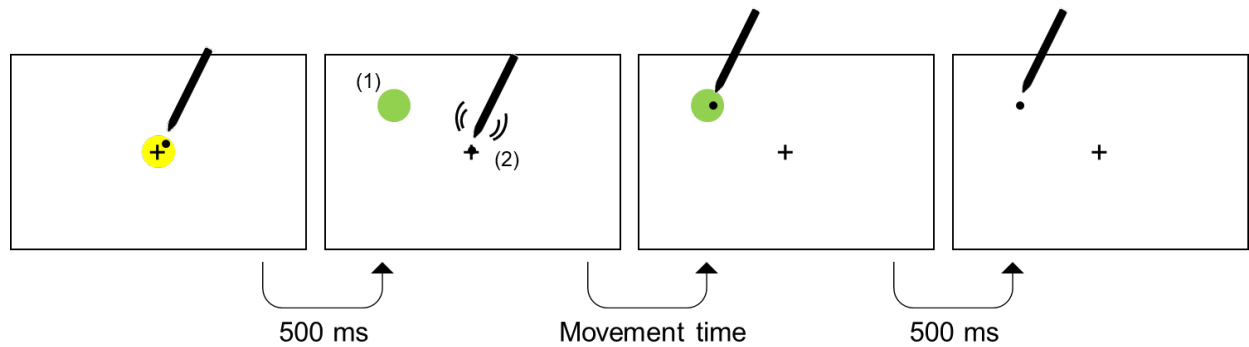

Figure 4: **Example of one trial in the visuomotor task.** After three seconds on the fixation cross, a yellow warning cue would appear. After the cursor was kept for 500 ms on the yellow circle, the warning cue would vanish and the target would appear in one of eight possible circular arranged positions on the screen (1). The movement time described the time between movement onset (2) and reaching the target. After 500ms on the target it vanished and the participant had to return to the fixation cross for the next trial.

3.2 Statistical analysis of behavioural task

The details of employed statistical tests have been presented in the original publication (de Almeida Marcelino *et al.*, 2019). Motor learning was assessed as improvement in movement times throughout the trials and calculated as follows:

$$\text{Motor learning} = \frac{\text{Average movement time in first 10\% of trials } (N = 3)}{\text{Average movement time in last 10\% of trials } (N = 3)} * 100$$

The very first and last trials were excluded to avoid begin/end of task distraction. Task improvement was compared between groups (healthy controls, PD patients on DBS and PD patients off DBS) using permutation tests. Here, the null hypothesis was tested that percentage task improvement from the tested individuals was interchangeable by comparing 5000 replications of the test statistic with randomly rearranged distribution of task improvement results between the tested groups. This procedure avoids any assumptions regarding the distribution of the measured parameters and is robust against small sample size (Neumann *et al.*, 2014).

To further assess changes in motor performance through practice, a power law regression function was fitted to averaged movement time throughout trials for all groups.

$$y \approx 1 + a \cdot x^b$$

y is trial averaged movement time
 x is the trial index

Motor sign alleviation was assessed as relative improvement in UPDRS-III total scores:

$$\text{Motor sign alleviation} = \frac{\text{UPDRS III OFF DBS} - \text{UPDRS III ON DBS}}{\text{UPDRS III OFF DBS}} * 100$$

DBS induced improvement in motor learning was calculated as difference between percentage task improvement on DBS and off DBS and used for learning specific connectivity analysis. Improvement in bradykinesia and rigidity subscores (UPDRS-III items 22-25) for the right upper extremity was assessed to test for the confounder that improvement in motor learning might be induced by improved agility of the right arm (as all patients were right-handed). In additional analyses not included in the original publication, the association between DBS induced task improvement and levodopa equivalent daily dose (LEDD), symptom laterality and stimulation parameters (double monopolar vs. single monopolar) was assessed through correlation or permutation tests (the latter for binary measures). MATLAB software (The MathWorks, Inc., Natick, Massachusetts, United States) was used for programming the task and computing all statistical analyses.

3.3 Electrode localization and functional MRI analysis

To analyse functional networks associated with DBS induced improvement in motor learning, electrode localization was performed using the latest version of Lead-DBS v2 (Horn *et al.*, 2019) for all patients but one, who had been operated elsewhere and for whom preoperative imaging was not available (Fig. 5). In the remaining cohort, pre-operative MRI and post-operative CT scans were co-registered and normalized to MNI (Montreal Neurological Institute) space. Active contacts were then represented as spherical regions of interest (ROI's) with a radius of 1 mm roughly reflecting the cylindrical DBS contacts (1.27mm diameter, 1.5mm length) as seed regions projected to an openly available group connectome derived from resting state functional connectivity MRI (rs-fcMRI) images of 1000 healthy volunteers (www.lead-dbs.org; Buckner *et al.*, 2011).

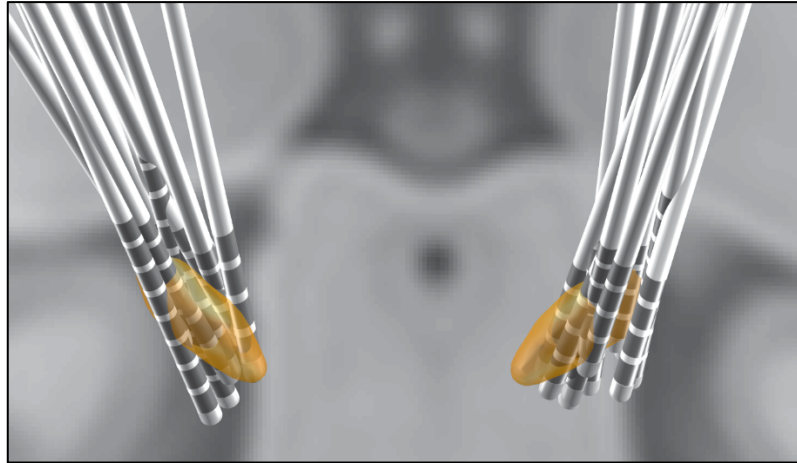

Figure 5: **Placement of DBS electrodes in the subthalamic nucleus.** Electrode localisation was performed with Lead-DBS (www.lead-dbs.org) for all Parkinson's disease patients included in the connectivity analysis (N=19).

The connectivity analysis builds on the hypothesis that DBS acts on a network level and modulates brain regions beyond the immediate proximity of the active contact. It was performed according to established methodology described previously (Boes *et al.*, 2015; Horn *et al.*, 2017; Joutsa *et al.*, 2018). In a first step, time series were sampled from active DBS contact location for each patient and correlated with time series of every other voxel in the brain, creating one connectivity profile for each patient ($R \times N_{\text{voxels}} \times N_{\text{patients}}$, where R = correlation coefficient and N = number). Then, functional connectivity from active contact was correlated with DBS induced changes in motor learning for each brain voxel ($R \times N_{\text{voxels}}$). This was depicted as an “R-map” of DBS induced motor learning (Figure 2B of de Almeida Marcelino *et al.*, 2019). Third, spatial correlation between the individual connectivity and the “optimal” R-Map was calculated for each patient ($R \times N_{\text{patients}}$). Lastly, the predictive potential of spatial correlation was assessed by correlating learning improvement for individual patients with spatial correlation to the “optimal” R-map ($1 \times R$; Figure 2C of de Almeida Marcelino *et al.*, 2019).

Linear regression analysis was additionally performed to test for predictive value on a priori defined region of interest (ROI) from M1 and bilateral cerebellum. Leave one out cross-validation (LOOCV) was performed in all significant regression models and correlations, including the whole brain connectivity analysis. Following potential confounders were added as regressors to the multivariate analyses: relative improvement in UPDRS-III total scores, bradykinesia/rigidity hemibody scores (items 22-25 of UPDRS-III), symptom laterality, levodopa equivalent daily doses, monopolar vs. double monopolar

seed regions. False discovery rate (FDR) was used for control of multiple comparisons. To refute the possibility that a basal ganglia - thalamo - cortico loop could underlie the connectivity results between basal ganglia and cerebellum, cerebellar functional connectivity maps seeded from bilateral STN were subtracted from the cerebellar connectivity maps seeded from bilateral M1 and visualised as a colour map (Figure 3D in de Almeida Marcelino *et al.*, 2019).

4. Results

A detailed report on the most important results from this study can be found in the original publication (de Almeida Marcelino *et al.*, 2019). Here, the main findings will be summarized and some detail about supportive analyses will be given.

4.1 Subthalamic DBS improves short-term motor learning in Parkinson's disease

First, motor learning as assessed through improvement between first and last 10% of trials was compared between the three groups: Parkinson's disease patients off DBS showed statistically significant reduced improvement in motor learning (PD off DBS: individual relative improvement: $12.2 \pm 5.4\%$ from $1311 \pm 160\text{ms}$ to $1089 \pm 118\text{ms}$ movement time; mean \pm S.E.M; $P=0.01$) when compared to on DBS (PD on DBS: $27.7 \pm 6.1\%$ from $940 \pm 120\text{ms}$ to $615 \pm 84\text{ms}$; PD off vs. on DBS; $P=0.01$) and healthy controls (healthy controls: $33.48 \pm 3.6\%$ from $729 \pm 63\text{ms}$ to $473 \pm 42\text{ms}$; healthy controls vs. PD off DBS; $P=0.002$). Subthalamic DBS improved motor learning to the level of healthy controls (healthy controls vs. PD on DBS, $P=0.4$). Trial by trial improvement in movement times followed a power law function for healthy controls ($R^2=0.91$, $P<0.001$) and Parkinson's disease patients on DBS (PD on DBS, $R^2=0.81$, $P<0.001$), differing mainly due to a higher offset of the latter defined as the intercept. Regressing trial by trial movement times for patients off stimulation did not lead to a statistically significant fit ($R^2=0.05$, $P=0.47$). Figure 6 is an adaptation of Figure 1 from de Almeida Marcelino *et al.*, 2019, representing these results.

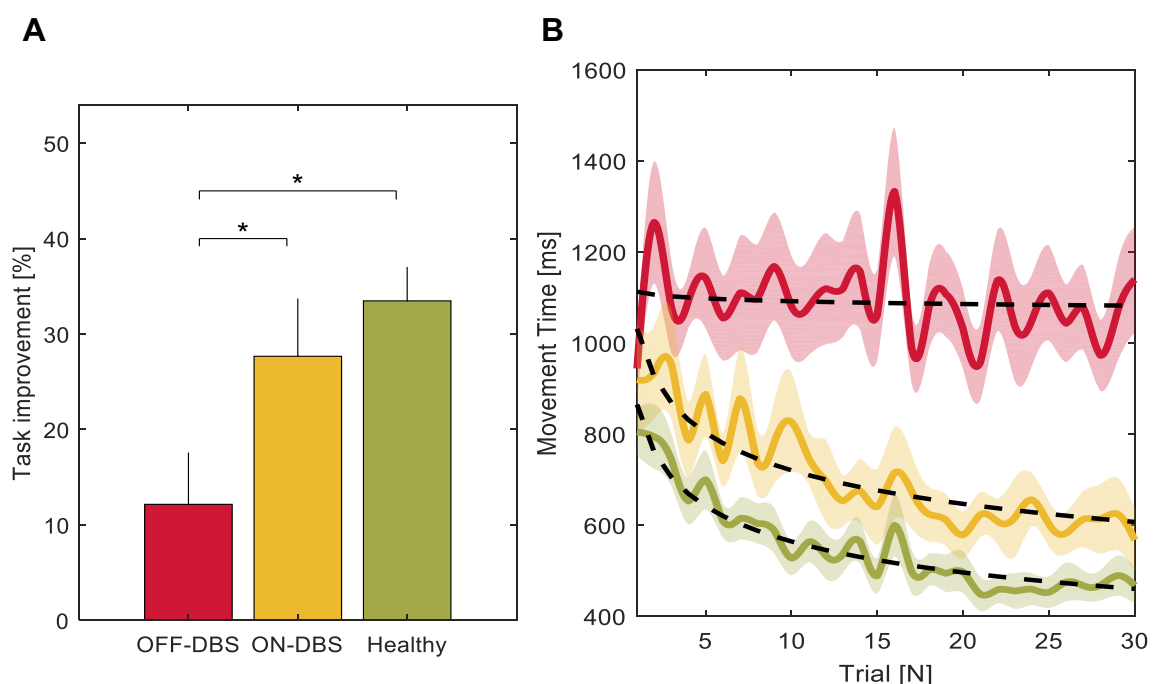

Figure 6: **Motor learning is impaired in Parkinson's disease patients off DBS and improved under active subthalamic DBS.** (A) Improvement in motor learning was reduced in Parkinson's disease patients off DBS comparing with healthy controls (PD off DBS vs. healthy controls, $P=0.002$) and with patients on DBS (PD off DBS vs. on DBS, $P=0.01$). Subthalamic DBS improved motor learning in Parkinson's disease patients to the level of healthy controls (PD on DBS vs. healthy controls, $P=0.4$). (B) A power law function was used to fit trial by trial improvement in motor execution. Parkinson's disease patients on DBS revealed a similar curve as healthy controls, only with a higher offset (see text for R values). The groups are represented by the same colours in both graphs (red = PD patients off DBS; yellow = PD patients on DBS; green = healthy controls). Figure adapted from original publication (de Almeida Marcelino *et al.*, 2019).

Even though subthalamic deep brain stimulation led to a statistical significant motor sign alleviation (off DBS: 28.9 ± 2.5 ; on DBS: 11.2 ± 1.2 points, $P<0.001$; Fig. 5), there was no significant correlation between task improvement and improvement in total UPDRS-III ($R=-0.02$, $P=0.5$; Fig. 6A) or bradykinesia/rigidity hemibody scores ($R=0.06$, $P=0.4$; Fig. 6B). More than that, daily levodopa equivalent dose did not correlate with DBS induced improvement in motor learning ($R=-0.28$, $P=0.12$; Fig. 7A). Improvement in motor learning was higher for right side dominant Parkinson's disease patients (ipsilateral to used hand), however this difference was not statistically significant (Right side dominant: $N=10$, $23.5 \pm 8.2\%$; Left side dominant: $N=10$, $7.52 \pm 8.8\%$; paired permutation test $P=0.14$; Fig. 7B).

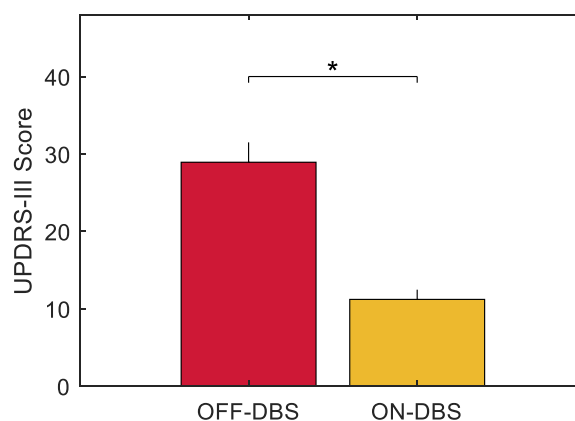

Figure 5: **Subthalamic DBS leads to a significant motor sign alleviation.** Subthalamic DBS successfully improved motor signs as reflected in reduction of total UPDRS-III scores ($P<0.001$); adapted from Neumann *et al.*, 2018.

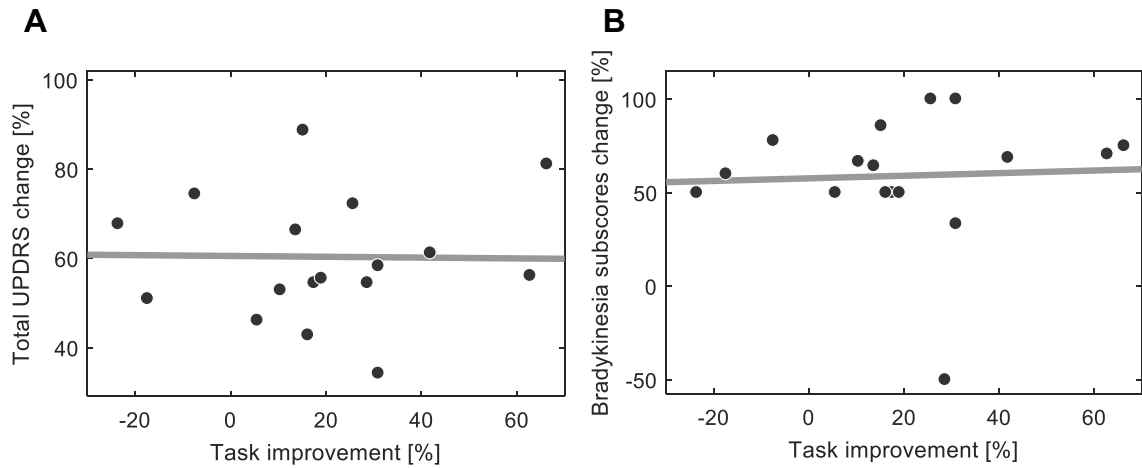

Figure 6: Motor sign alleviation does not correlate with DBS induced motor learning. Neither DBS induced change in total UPDRS-III score (**A**) ($R=-0.02$, $P=0.5$) nor in right upper extremity bradykinesia subscores (**B**) ($R=0.06$, $P=0.4$) correlated with DBS induced task improvement. Figure 6A was adapted from de Almeida Marcelino *et al.* 2019 (Figure 2A in de Almeida Marcelino *et al.*, 2019).

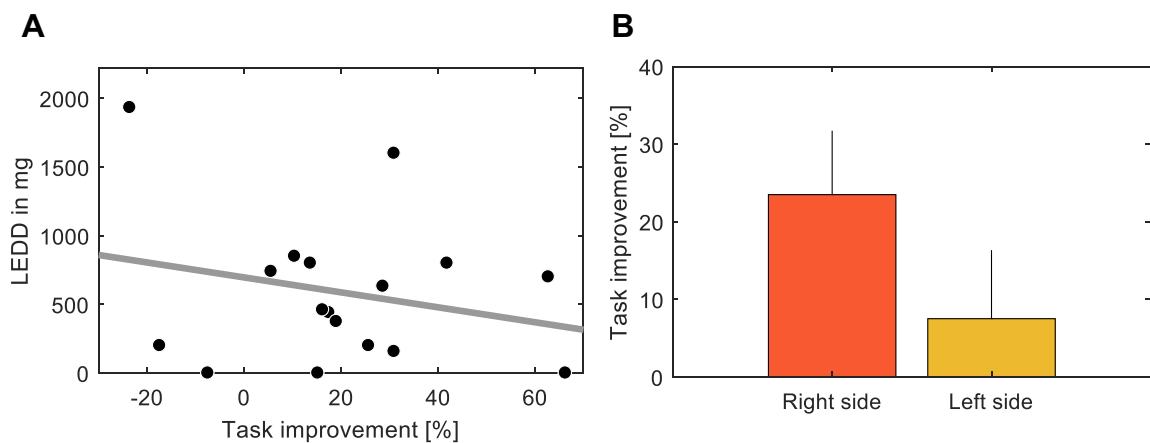

Figure 7: Levodopa intake and motor sign laterality are not associated with DBS induced motor learning. Levodopa equivalent dose did not correlate with DBS induced task improvement (**A**) ($R=-0.28$, $P=0.12$). Furthermore, there was no significant difference between improvement in motor learning for right and left dominant side (**B**) (paired permutation test $P=0.14$).

Seven of the 20 patients had double monopolar settings (cases 3, 6, 8, 11, 12, 15 and 19). No significant difference was found between the double monopolar stimulated patients and the remaining cohort with respect to DBS induced change in motor learning ($P=0.5$).

4.2 Motor learning correlates with resting state functional connectivity profiles of active DBS contacts

To assess the predictive value of DBS neural circuit profiles for improvement in motor learning, fMRI connectivity maps were derived from connectomic resting-state fMRI data (N=1000 healthy subjects; Horn *et al.*, 2017). This method has been proven powerful in the identification of underlying network implications of stimulation and focal lesions in psychiatric and neurological diseases (Boes *et al.*, 2015; Horn *et al.*, 2017; Joutsa *et al.*, 2018). The optimal fMRI connectivity profile from active DBS contacts for DBS induced motor learning was visualised as a whole-brain R-map (see Figure 2B of de Almeida Marcelino *et al.*, 2019). Spatial correlation between individual connectivity profiles and the “optimal” R-map could significantly explain variance in task improvement under DBS (N=19; $R^2=0.33$, $P=0.01$; LOOCV: $R=0.43$, $P=0.028$).

Furthermore, functional connectivity from the active contact to bilateral M1 and cerebellum could explain 58% of the variance in DBS induced task improvement in an additional region of interest analysis (Figure 3A of de Almeida Marcelino *et al.*, 2019; multivariable linear regression; $R^2=0.58$, $P=0.01$ and $R=0.5$, $P=0.004$ for LOOCV). More than that, functional connectivity from active DBS contacts to right cerebellar hemisphere was the strongest predictor for DBS induced motor learning ($R^2=0.34$, $P=0.008$; LOOCV: $R=0.045$, $P=0.02$) with peak predictive voxels locating to Crus II of Lobule VII ($R=0.71$; $P<0.001$; Fig. 8). Here, connectivity to STN was greater than connectivity to M1 (Fig. 3D in de Almeida Marcelino *et al.*, 2019).

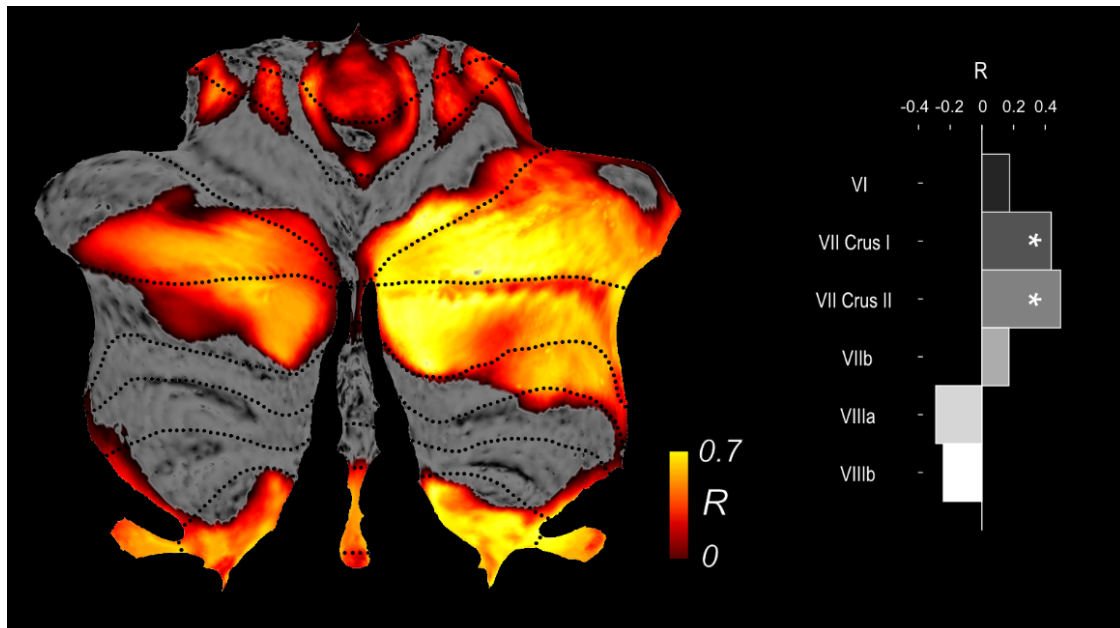

Figure 8: **Functional connectivity from active DBS contacts to the right cerebellar hemisphere is associated with DBS induced motor learning.** On the left hand side, a flattened cerebellum is depicted that shows in red to yellow tones increasing correlation values between connectivity from active DBS contact and DBS induced motor learning (Part of Figure 3C of de Almeida Marcelino *et al.*, 2019). On the right hand side, correlation between connectivity from DBS contacts to the different cerebellar lobules is depicted as bar charts. Peak predictive voxels corresponded to Crus II of Lobule VII ($R=0.71$; $P<0.001$), overlapping with the injection site of the anatomical study that described for the first time the disynaptic pathway between cerebellar hemispheres and the subthalamic nucleus (Bostan *et al.*, 2010).

Adding active contact seed region (monopolar vs. double monopolar) and symptom laterality as binary predictors into the multivariate analysis did not yield significant predictive performance. Relative improvement in UPDRS-III total scores and bradykinesia/rigidity hemibody scores (items 22-25 of UPDRS-III), symptom laterality, levodopa equivalent daily doses and active contact seed region were rejected in the stepwise model selection. Thus, a systematic effect of these potential confounders in the correlation and regression analysis can be excluded.

5. Discussion

Four conclusions can be drawn from this study: first, short-term motor learning is impaired in Parkinson's disease patients off DBS and can - at least partially - be restored through activation of subthalamic stimulation. Second, DBS induced improvement in motor learning is associated with functional connectivity to a specific brain network comprising the ipsilateral cerebellum. Third, functional connectivity from the active DBS contacts to the latter was shown to be the highest predictor for improvement in motor learning under STN-DBS. Lastly, the cerebellar areas most associated with DBS induced motor learning overlap with the source of direct subthalamic-cerebellar projections demonstrated in previous anatomy studies (Bostan *et al.*, 2010) and show higher connectivity to bilateral STN than to the motor cortex in our study.

5.1 Clinical aspects and limitations: dopamine replacement, disease laterality and stimulation parameters

Parkinsonian patients off DBS revealed reduced task improvement comparing with the on DBS condition and healthy controls. The poor performance of Parkinson's disease patients off DBS in spite of being on their usual medication might seem surprising. Dopaminergic medication was very heterogeneous across patients as stimulation parameters were set for best possible effect and the levodopa dose aimed to compensate for the remaining debilitations. Thus, there were patients that could refrain from any oral levodopa as the DBS effect was satisfying. Our results show no significant association between learning rates and levodopa dose (including analysis for off DBS condition only; $P > 0.1$). A previous study on motor learning in Parkinson's disease investigating on vs. off levodopa "a priori" did not find levodopa induced improvement in performance (Mure *et al.*, 2012). Moreover, a recent study in healthy controls comparing the effect of levodopa and dopaminergic antagonists did also not find any relevant improvement or detriment in memory based motor adaptation (Quattrocchi *et al.*, 2018). One explanation could be that DBS may indeed have a more specific effect on the basal ganglia cerebellar route, which will be discussed later in this chapter. Furthermore, ambiguous results in literature regarding the role of dopamine in learning might be attributed to the highly selective loss of dopaminergic cells in Parkinson's disease (Ehringer and Hornykiewicz, 1960). Since iatrogenic dopamine replacement reaches all dopamine receptors in the brain, supplying structures affected early in course of disease with dopamine might have a positive impact

on patients' performance, whereas dopamine replacement in other not yet affected areas might lead to an "overdose effect" and herewith compromise the normal functioning of the networks involved - the so-called "dopamine-overdose hypothesis" (Gotham *et al.*, 1988). Even though imaging results were lateralized to the right cerebellar hemisphere, right and left motor symptom predominant sides did not present a statistically significant difference in motor learning. A previous imaging study on motor learning in Parkinson's disease had also shown an increased activation of the right cerebellar hemisphere (Mure *et al.*, 2012). These studies further share the fact that outcome measures were derived from right hand movements in only right-handed subjects. To further investigate whether this lateralization reflects anatomical asymmetry or is a consequence of the used hand the same study should include a set of trials including the contralateral hand and patient specific imaging would be more appropriate as well as a subgroup of left-handed patients. In this study, stimulation parameters were set for optimal motor symptom alleviation and differed between patients. More than that, parameters were left unchanged during performance of task. It would be interesting to alter stimulation in an additional control condition as to maximize stimulation of areas functionally connected to the cerebellum. Lastly, our results rule out a potential systematic bias of larger seed regions in double monopolar settings.

These considerations point out the complexity of investigating behaviour in Parkinson's disease: disease stage and severity, motor symptom laterality, dopaminergic treatment, stimulation parameters are all factors that can influence performance and beg for a cautious interpretation of results.

5.3 Neural circuits underlying motor learning

Motor learning is essential for survival across different species and therefore depends on phylogenetically well preserved brain structures such as the basal ganglia and the cerebellum (Shmuelof and Krakauer, 2011). A recent viral tracing study on macaques has suggested that the STN sends efferent projections to the cerebellar hemispheres via a pontine synapse (Bostan *et al.*, 2010), defying the traditional view that basal ganglia and cerebellum only exchange information at a cortical level (Caligiore *et al.*, 2017). These findings add yet another circuit that can be modulated by subthalamic DBS. In the present study, DBS leads to an improvement in motor learning that is independent of DBS induced motor sign alleviation. Hence, we hypothesize that there are different, specific network changes underlying this effect and argue that modulation of basal ganglia - cerebellar

interactions might play a decisive role. We demonstrate that connectivity of DBS active contact location to the cerebellar hemispheres was associated with a greater improvement in learning through DBS. More than that, the voxels with highest predictive value within the cerebellum corresponded to the injection site of the abovementioned anatomical study (Bostan *et al.*, 2010), Crus II of Lobule VII. Also, that same location in the cerebellar hemispheres showed greater connectivity to the STN than to the motor cortex (M1) when assessing the normative group connectome (1000 healthy subjects). While the present findings suggest that modulation of the subthalamic cerebellar pathway might enhance DBS induced motor learning, the circuit mechanisms behind this effect remain to be elucidated. The concept of deep brain stimulation was derived from the antiparkinsonian effect of ablative basal ganglia surgery (Bergman *et al.*, 1990). Even though its mechanism of action is still not fully understood, DBS is thought to modulate local neural activity by suppressing pathologically exaggerated synchronicity (DeLong and Wichmann, 2007). This has been replicated in Parkinson's disease patients through recording of local field potentials of the STN, where increased activity in the beta band was attenuated under subthalamic DBS (Kühn *et al.*, 2008). Failure to suppress beta activity has been associated with impaired motor learning in Parkinson's disease (Herrojo Ruiz *et al.*, 2014). Previous neuroimaging studies have reported aberrant activity in cerebellar hemispheres of Parkinson's disease patients in the resting state that can be modulated by DBS (Payoux *et al.*, 2004; Asanuma *et al.*, 2006; Wu and Hallett, 2013). More than that, increased activity in cerebellar output nuclei under subthalamic DBS has been shown in wildtype and 6-OHDA lesioned parkinsonian rats (Sutton *et al.*, 2015; Bostan and Strick, 2018). One could argue that aberrant subthalamic output to cerebellar hemispheres in Parkinson's disease is modulated through subthalamic deep brain stimulation, leading to disinhibition in downstream cerebellar activity (Bostan and Strick, 2018; de Almeida Marcelino *et al.*, 2019). Facilitation of motor learning could occur by allowing basal ganglia driven signals to update cerebellar forward models with short-latency, and the cerebellar output nuclei could, in turn, convey the striatum with information for "real-time" adaptation of basal ganglia output (Caligiore *et al.*, 2017). Currently, this hypothesis remains speculative and must be assessed in further studies. All in all, the contributions of basal ganglia cerebellar connections to Parkinson's disease represent complex processes that are still beginning to be clarified. Motor learning might be one of the functional applications of these connections. In order to understand to what

extent it is influenced by deep brain stimulation and investigate other possible applications further studies are necessary.

5.3 Outlook

In the following, the main resulting scientific issues and clinical applications will be addressed. First, one can conclude that more studies assessing the role of dopamine and deep brain stimulation on motor learning in Parkinson's disease are needed as there is a gap in literature for this topic. Therapeutic implications could arise from future work in this field: for example, in a cross-over design one could investigate the role of DBS in retention of motor learning, which would be relevant for enhancing rehabilitative processes to improve activities of daily living. Second, this study highlights the utility of connectomics to understand function of targeted networks and mechanisms of DBS. This methodology has been gaining relevance in the past years, as it is not invasive and increasingly accessible. Future studies should investigate the role of network modulation of individual connectivity profiles through DBS and associated changes in movement kinematics and cognitive aspects of movement execution in Parkinson's disease. To this end, Parkinson's disease patients could perform the visuomotor task as described in Neumann *et al.*, 2018 and undergo fMRI scans on and off DBS. Third, investigating the functionality of neural circuits and networks is highly relevant to optimise targeted treatments such as deep brain stimulation. With increasing quality of clinically available MRI scans, DBS targets may be chosen based on connectivity measures relating to circuit connections. Furthermore, the long-term goal would be to adapt stimulation to "real-time" necessities in a closed loop fashion either by becoming active only when needed or even by switching active contacts depending on the required circuit modulation. To transfer these concepts to current practice, more research is required.

5.4 Conclusion

To conclude with, the present study integrates behavioural data and connectivity analyses to investigate the interactions between the basal ganglia, the cerebellum, motor learning and Parkinson's disease. Motor learning is impaired in Parkinson's disease patients off stimulation and subthalamic DBS may restore this ability through modulation of specific basal ganglia cerebellar communication pathways. These findings point out the utility of DBS in investigating behaviour in disease and emphasize that network

modulation might be a mechanism of DBS. The presented evidence is relevant for developing intelligent adaptive neuromodulation technologies supporting patients to tackle the challenges of everyday life with Parkinson's disease.

Bibliography

Accolla EA, Herrojo Ruiz M, Horn A, Schneider G-H, Schmitz-Hübsch T, Draganski B, Kühn AA. Brain networks modulated by subthalamic nucleus deep brain stimulation. *Brain* 2016; 139: 2503–2515.

Albin RL, Young AB, Penney JB. The functional anatomy of basal ganglia disorders. *Trends Neurosci* 1989; 12: 366–375.

Alexander GE, DeLong MR, Strick PL. Parallel organization of functionally segregated circuits linking basal ganglia and cortex. *Annu Rev Neurosci* 1986; 9: 357–381.

de Almeida Marcelino AL, Horn A, Krause P, Kühn AA, Neumann W-J. Subthalamic neuromodulation improves short-term motor learning in Parkinson's disease [Epub ahead of print]. *Brain* 2019 [cited 2019 Jun 12] Available from: <https://academic.oup.com/brain/advance-article/doi/10.1093/brain/awz152/5512025>

Asanuma K, Tang C, Ma Y, Dhawan V, Mattis P, Edwards C, Kaplitt MG, Feigin A, Eidelberg D. Network modulation in the treatment of Parkinson's disease. *Brain* 2006; 129: 2667–2678.

Bastian AJ. Learning to predict the future: the cerebellum adapts feedforward movement control. *Curr Opin Neurobiol* 2006; 16: 645–649.

Bergman H, Wichmann T, DeLong MR. Reversal of experimental parkinsonism by lesions of the subthalamic nucleus. *Science* (80-) 1990; 249: 1436–1438.

Bergman H, Wichmann T, Karmon B, DeLong MR. The primate subthalamic nucleus. II. Neuronal activity in the MPTP model of parkinsonism. *J Neurophysiol* 1994; 72: 507–520.

Boes AD, Prasad S, Liu H, Liu Q, Pascual-Leone A, Caviness VS, Fox MD. Network localization of neurological symptoms from focal brain lesions. *Brain* 2015; 138: 3061–3075.

Bostan AC, Dum RP, Strick PL. The basal ganglia communicate with the cerebellum. *Proc Natl Acad Sci U S A* 2010; 107: 8452–6.

Bostan AC, Strick PL. The basal ganglia and the cerebellum: nodes in an integrated

network. *Nat Rev Neurosci* 2018; 19: 338–350.

Brown RG, Jahanshahi M, Limousin-Dowsey P, Thomas D, Quinn NP, Rothwell JC. Pallidotomy and incidental sequence learning in Parkinson's disease. *Neuroreport* 2003; 14: 21–4.

Buckner RL, Krienen FM, Castellanos A, Diaz JC, Yeo BTT. The organization of the human cerebellum estimated by intrinsic functional connectivity. *J Neurophysiol* 2011; 106: 2322–2345.

Caligiore D, Pezzulo G, Baldassarre G, Bostan AC, Strick PL, Doya K, Helmich RC, Dirx M, Houk J, Jörntell H, Lago-Rodriguez A, Galea JM, Miall RC, Popa T, Kishore A, Verschure PFMJ, Zucca R, Herreros I. Consensus Paper: Towards a Systems-Level View of Cerebellar Function: the Interplay Between Cerebellum, Basal Ganglia, and Cortex. *Cerebellum* 2017; 16: 203–229.

Catalan MJ, Ishii K, Honda M, Samii A, Hallett M. A PET study of sequential finger movements of varying length in patients with Parkinson's disease. *Brain* 1999; 122: 483–495.

DeLong MR. Primate models of movement disorders of basal ganglia origin. *Trends Neurosci* 1990; 13: 281–285.

DeLong MR, Wichmann T. Circuits and Circuit Disorders of the Basal Ganglia. *Arch Neurol* 2007; 64: 20.

Deuschl G, Schade-Brittinger C, Krack P, Volkmann J, Schäfer H, Bötzel K, Daniels C, Deutschländer A, Dillmann U, Eisner W, Gruber D, Hamel W, Herzog J, Hilker R, Klebe S, Kloss M, Koy J, Krause M, Kupsch A, Lorenz D, Lorenzl S, Mehdorn HM, Moringlane JR, Oertel W, Pinski MO, Reichmann H, Reuss A, Schneider GH, Schnitzler A, Steude U, Sturm V, Timmermann L, Tronnier V, Trottenberg T, Wojtecki L, Wolf E, Poewe W, Voges J, German Parkinson Study Group N. A randomized trial of deep-brain stimulation for Parkinson's disease. *N Engl J Med* 2006; 355: 896–908.

Ehringer H, Hornykiewicz O. [Distribution of noradrenaline and dopamine (3-hydroxytyramine) in the human brain and their behavior in diseases of the extrapyramidal system]. *Klin Wochenschr* 1960; 38: 1236–1239.

Floyer-Lea A, Matthews PM. Changing Brain Networks for Visuomotor Control With Increased Movement Automaticity. *J Neurophysiol* 2004; 92: 2405–2412.

Forno LS. Neuropathology of Parkinson's disease. *J Neuropathol Exp Neurol* 1996; 55: 259–272.

Frank MJ, Samanta J, Moustafa AA, Sherman SJ. Hold your horses: Impulsivity, deep brain stimulation, and medication in Parkinsonism. *Science* (80-) 2007; 318: 1309–1312.

Gotham AM, Brown RG, Marsden CD. 'Frontal' cognitive function in patients with Parkinson's disease 'on' and 'off' levodopa. *Brain* 1988; 111: 299–321.

Green N, Bogacz R, Huebl J, Beyer AK, Kühn AA, Heekeren HR. Reduction of influence of task difficulty on perceptual decision making by STN deep brain stimulation. *Curr Biol* 2013; 23: 1681–1684.

Herrojo Ruiz M, Brücke C, Nikulin V V., Schneider G-H, Kühn AA. Beta-band amplitude oscillations in the human internal globus pallidus support the encoding of sequence boundaries during initial sensorimotor sequence learning. *Neuroimage* 2014; 85: 779–793.

Herz DM, Little S, Pedrosa DJ, Tinkhauser G, Cheeran B, Foltynie T, Bogacz R, Brown P. Mechanisms Underlying Decision-Making as Revealed by Deep-Brain Stimulation in Patients with Parkinson's Disease. *Curr Biol* 2018; 28: 1169–1178.e6.

Herz DM, Zavala BA, Bogacz R, Brown P. Neural Correlates of Decision Thresholds in the Human Subthalamic Nucleus. *Curr Biol* 2016; 26: 916–920.

Horn A, Li N, Dembek TA, Kappel A, Boulay C, Ewert S, Tietze A, Husch A, Perera T, Neumann W-J, Reiser M, Si H, Oostenveld R, Rorden C, Yeh F-C, Fang Q, Herrington TM, Vorwerk J, Kühn AA. Lead-DBS v2: Towards a comprehensive pipeline for deep brain stimulation imaging. *Neuroimage* 2019; 184: 293–316.

Horn A, Reich M, Vorwerk J, Li N, Wenzel G, Fang Q, Schmitz-Hübsch T, Nickl R, Kupsch A, Volkmann J, Kühn AA, Fox MD. Connectivity Predicts deep brain stimulation outcome in Parkinson disease. *Ann Neurol* 2017; 82: 67–78.

Joutsa J, Horn A, Hsu J, Fox MD. Localizing parkinsonism based on focal brain lesions.

Brain 2018; 141: 2445–2456.

Kahan J, Urner M, Moran R, Flandin G, Marreiros A, Mancini L, White M, Thornton J, Yousry T, Zrinzo L, Hariz M, Limousin P, Friston K, Foltynie T. Resting state functional MRI in Parkinson's disease: the impact of deep brain stimulation on 'effective' connectivity. *Brain* 2014; 137: 1130–1144.

Kühn AA, Kempf F, Brücke C, Gaynor Doyle L, Martinez-Torres I, Pogosyan A, Trottenberg T, Kupsch A, Schneider GH, Hariz MI, Vandenberghe W, Nuttin B, Brown P. High-frequency stimulation of the subthalamic nucleus suppresses oscillatory beta activity in patients with Parkinson's disease in parallel with improvement in motor performance. *J Neurosci* 2008; 28: 6165–6173.

Lang AE, Lozano AM. Parkinson's Disease. *N Engl J Med* 1998; 339: 1044–1053.

Lehericy S, Benali H, Van de Moortele P-F, Pelegrini-Issac M, Waechter T, Ugurbil K, Doyon J. Distinct basal ganglia territories are engaged in early and advanced motor sequence learning. *Proc Natl Acad Sci* 2005; 102: 12566–12571.

Marinelli L, Quartarone A, Hallett M, Frazzitta G, Ghilardi MF. The many facets of motor learning and their relevance for Parkinson's disease. *Clin Neurophysiol* 2017; 128: 1127–1141.

Miyachi S, Hikosaka O, Miyashita K, Kárádi Z, Kato Rand M. Differential roles of monkey striatum in learning. *Exp Brain Res* 1997; 115: 1–5.

Mure H, Tang CC, Argyelan M, Ghilardi M-F, Kaplitt MG, Dhawan V, Eidelberg D. Improved Sequence Learning with Subthalamic Nucleus Deep Brain Stimulation: Evidence for Treatment-Specific Network Modulation. *J Neurosci* 2012; 32: 2804–2813.

Nakamura T, Ghilardi MF, Mentis M, Dhawan V, Fukuda M, Hacking A, Moeller JR, Ghez C, Eidelberg D. Functional networks in motor sequence learning: Abnormal topographies in Parkinson's disease. *Hum Brain Mapp* 2001; 12: 42–60.

Nambu A, Tokuno H, Takada M. Functional significance of the cortico-subthalamo-pallidal 'hyperdirect' pathway. *Neurosci Res* 2002; 43: 111–117.

Neumann W-J, Schroll H, de Almeida Marcelino AL, Horn A, Ewert S, Irmen F, Krause P,

Schneider G-H, Hamker F, Kühn AA. Functional segregation of basal ganglia pathways in Parkinson's disease. *Brain* 2018; 141: 2655–2669.

Neumann WJ, Huebl J, Brücke C, Gabriëls L, Bajbouj M, Merkl A, Schneider GH, Nuttin B, Brown P, Kühn AA. Different patterns of local field potentials from limbic DBS targets in patients with major depressive and obsessive compulsive disorder. *Mol Psychiatry* 2014; 19: 1186–1192.

Payoux P, Remy P, Damier P, Miloudi M, Loubinoux I, Pidoux B, Gaura V, Rascol O, Samson Y, Agid Y. Subthalamic nucleus stimulation reduces abnormal motor cortical overactivity in Parkinson disease. *ArchNeurol* 2004; 61: 1307–1313.

Poewe W, Seppi K, Tanner CM, Halliday GM, Brundin P, Volkman J, Schrag A-E, Lang AE. Parkinson disease. *Nat Rev Dis Prim* 2017; 3: 17013.

Postuma RB, Berg D, Stern M, Poewe W, Olanow CW, Oertel W, Obeso J, Marek K, Litvan I, Lang AE, Halliday G, Goetz CG, Gasser T, Dubois B, Chan P, Bloem BR, Adler CH, Deuschl G. MDS clinical diagnostic criteria for Parkinson's disease. *Mov Disord* 2015; 30: 1591–1601.

Quattrocchi G, Monaco J, Ho A, Irmen F, Strube W, Ruge D, Bestmann S, Galea JM. Pharmacological Dopamine Manipulation Does Not Alter Reward-Based Improvements in Memory Retention during a Visuomotor Adaptation Task. *eneuro* 2018; 5: ENEURO.0453-17.2018.

Schuepbach WMM, Rau J, Knudsen K, Volkman J, Krack P, Timmermann L, Hälbig TD, Hesekamp H, Navarro SM, Meier N, Falk D, Mehdorn M, Paschen S, Maarouf M, Barbe MT, Fink GR, Kupsch A, Gruber D, Schneider G-H, Seigneuret E, Kistner A, Chaynes P, Ory-Magne F, Brefel Courbon C, Vesper J, Schnitzler A, Wojtecki L, Houeto J-L, Bataille B, Maltête D, Damier P, Raoul S, Sixel-Doering F, Hellwig D, Gharabaghi A, Krüger R, Pinski MO, Amage F, Régis J-M, Witjas T, Thobois S, Mertens P, Kloss M, Hartmann A, Oertel WH, Post B, Speelman H, Agid Y, Schade-Brittinger C, Deuschl G. Neurostimulation for Parkinson's Disease with Early Motor Complications. *N Engl J Med* 2013; 368: 610–622.

Shmuelof L, Krakauer JW. Are we ready for a natural history of motor learning? *Neuron* 2011; 72: 469–476.

Sutton AC, O'Connor KA, Pilitsis JG, Shin DS. Stimulation of the subthalamic nucleus engages the cerebellum for motor function in parkinsonian rats. *Brain Struct Funct* 2015; 220: 3595–3609.

Volkman J, Daniels C, Witt K. Neuropsychiatric effects of subthalamic neurostimulation in Parkinson disease. *Nat Rev Neurol* 2010; 6: 487–498.

Weaver FM, Follett KA, Stern M, Luo P, Harris CL, Hur K, Marks WJ, Rothlind J, Sagher O, Moy C, Pahwa R, Burchiel K, Hogarth P, Lai EC, Duda JE, Holloway K, Samii A, Horn S, Bronstein JM, Stoner G, Starr PA, Simpson R, Baltuch G, De Salles A, Huang GD, Reda DJ, Group CSP 468 S. Randomized trial of deep brain stimulation for Parkinson disease: thirty-six-month outcomes. *Neurology* 2012; 79: 55–65.

Weiner MJ, Hallett M, Funkenstein HH. Adaptation to lateral displacement of vision in patients with lesions of the central nervous system. *Neurology* 1983; 33: 766–72.

Wu T, Chan P, Hallett M. Effective connectivity of neural networks in automatic movements in Parkinson's disease. *Neuroimage* 2010; 49: 2581–2587.

Wu T, Hallett M. The cerebellum in Parkinson's disease. *Brain* 2013; 136: 696–709.

Statutory Declaration

“I, Ana Luísa de Almeida Marcelino, by personally signing this document in lieu of an oath, hereby affirm that I prepared the submitted dissertation on the topic “The effect of subthalamic deep brain stimulation on motor learning in Parkinson’s disease”, independently and without the support of third parties, and that I used no other sources and aids than those stated.

All parts which are based on the publications or presentations of other authors, either in letter or in spirit, are specified as such in accordance with the citing guidelines. The sections on methodology (in particular regarding practical work, laboratory regulations, statistical processing) and results (in particular regarding figures, charts and tables) are exclusively my responsibility.

My contributions to any publications to this dissertation correspond to those stated in the below joint declaration made together with the supervisor. All publications created within the scope of the dissertation comply with the guidelines of the ICMJE (International Committee of Medical Journal Editors; www.icmje.org) on authorship. In addition, I declare that I am aware of the regulations of Charité – Universitätsmedizin Berlin on ensuring good scientific practice and that I commit to comply with these regulations.

The significance of this statutory declaration and the consequences of a false statutory declaration under criminal law (Sections 156, 161 of the German Criminal Code) are known to me.”

Date

Signature

Detailed declaration of own contribution to the top-journal publication

Ana Luísa de Almeida Marcelino contributed the following to the below listed publication:

Publication:

Ana Luísa de Almeida Marcelino, Andreas Horn, Patricia Krause, Andrea A Kühn, Wolf-Julian Neumann, Subthalamic neuromodulation improves short-term motor learning in Parkinson's disease [Epub ahead of print], *Brain* 2019, awz152, <https://doi.org/10.1093/brain/awz152>

Detailed declaration of own contribution:

Ana Marcelino started this project in 2014 in the context of the “Hausarbeit” in the 6th semester of her medical course at the Charité Berlin and played a leading role until its completion, then as a medical doctor at the department for Neurology of the Charité. Two publications arose from this project: Neumann et al. 2018 and de Almeida Marcelino et al. 2019. This dissertation focusses on the second.

In a first phase, Ana Marcelino actively contributed to the development and optimisation of the task used for both publications. To this end, she performed pilot measurements on Parkinson's disease patients and healthy controls and analysed behavioural results statistically in order to adapt the task to the impaired motor capabilities of Parkinson's disease patients. Implementing the task laid the groundwork for a successful continuation of the project.

Once the task was set, Ana Marcelino recruited Parkinson's disease patients from the Movement Disorders Department and outpatient clinic at the “Charité Campus Virchow Klinikum” as well as age-matched healthy subjects. She performed all measurements autonomously. This included obtaining informed consent, instructing participants about the task as well as technically setting up the measurements. She performed a clinical neurological examination and completed the motor part of the Unified Parkinson's Disease Rating Scale (III) for all Parkinson's disease patients on and off stimulation. She adapted DBS parameters to conform to the study protocol. Thus, Ana Marcelino acquired all behavioural primary data for both publications.

Ana Marcelino contributed substantially to the conception and implementation of the study on motor learning in the context of the current state of research. She applied the knowledge gained in the first phase of the project and first publication on analysing

behavioural data and focussed on the behavioural effects of deep brain stimulation in Parkinson's disease on motor learning. She composed and managed all behavioural and clinical data (e.g. see "Table 1" of the manuscript) and participated in the analysis and interpretation of the functional connectivity data, which were led by Wolf-Julian Neumann. Ana Marcelino wrote the first draft of the publication autonomously, which was then revised by all co-authors under leading supervision of Wolf-Julian Neumann and Andrea Kühn before submission to the journal. Ana Marcelino was the corresponding author with the journal throughout the whole submission process. She integrated the comments of peer reviewers in the manuscript and wrote the first draft of the response letter, which was completed with all co-authors under lead of Wolf-Julian Neumann.

Signature, date and stamp of supervising university professor (Frau Prof. Andrea Kühn)

Signature of doctoral candidate (Ana Luísa de Almeida Marcelino)

Extract from the Journal Summary List (ISI Web of KnowledgeSM)

Journal Data Filtered By: **Selected JCR Year: 2017** Selected Editions: SCIE,SSCI
 Selected Categories: **"NEUROSCIENCES"** Selected Category Scheme: WoS
Gesamtanzahl: 261 Journale

Rank	Full Journal Title	Total Cites	Journal Impact Factor	Eigenfactor Score
1	NATURE REVIEWS NEUROSCIENCE	40,834	32.635	0.069940
2	NATURE NEUROSCIENCE	59,426	19.912	0.153710
3	ACTA NEUROPATHOLOGICA	18,783	15.872	0.041490
4	TRENDS IN COGNITIVE SCIENCES	25,391	15.557	0.040790
5	BEHAVIORAL AND BRAIN SCIENCES	8,900	15.071	0.010130
6	Annual Review of Neuroscience	13,320	14.675	0.016110
7	NEURON	89,410	14.318	0.216730
8	PROGRESS IN NEUROBIOLOGY	13,065	14.163	0.015550
9	BIOLOGICAL PSYCHIATRY	42,494	11.982	0.056910
10	MOLECULAR PSYCHIATRY	18,460	11.640	0.047200
11	JOURNAL OF PINEAL RESEARCH	9,079	11.613	0.008600
12	TRENDS IN NEUROSCIENCES	20,061	11.439	0.026860
13	BRAIN	52,061	10.840	0.075170
14	SLEEP MEDICINE REVIEWS	6,080	10.602	0.010720
15	ANNALS OF NEUROLOGY	37,251	10.244	0.053390
16	Translational Stroke Research	2,202	8.266	0.005260
17	NEUROSCIENCE AND BIOBEHAVIORAL REVIEWS	24,279	8.037	0.048460
18	NEUROSCIENTIST	4,738	7.461	0.008730
19	NEURAL NETWORKS	10,086	7.197	0.015290
20	FRONTIERS IN NEUROENDOCRINOLOGY	3,924	6.875	0.006040
21	NEUROPSYCHOPHARMACOLOGY	24,537	6.544	0.042870
22	CURRENT OPINION IN NEUROBIOLOGY	14,190	6.541	0.034670

Printed copy of the publication

Ana Luísa de Almeida Marcelino, Andreas Horn, Patricia Krause, Andrea A Kühn, Wolf-Julian Neumann, Subthalamic neuromodulation improves short-term motor learning in Parkinson's disease, *Brain*, Volume 142, Issue 8, August 2019, Pages 2198–2206, <https://doi.org/10.1093/brain/awz152>

Curriculum vitae

My curriculum vitae does not appear in the electronic version of my dissertation for reasons of data protection.

Complete list of publications

Peer-reviewed journals:

1. Ana Luísa de Almeida Marcelino, Andreas Horn, Patricia Krause, Andrea A Kühn, Wolf-Julian Neumann, Subthalamic neuromodulation improves short-term motor learning in Parkinson's disease [Epub ahead of print], *Brain* 2019, awz152, <https://doi.org/10.1093/brain/awz152> (Impact factor 10.84)

2. Wolf-Julian Neumann, Henning Schroll, Ana Luisa de Almeida Marcelino, Andreas Horn, Siobhan Ewert, Friederike Irmen, Patricia Krause, Gerd-Helge Schneider, Fred Hamker, Andrea A Kühn, Functional segregation of basal ganglia pathways in Parkinson's disease, *Brain*, Volume 141, Issue 9, September 2018, Pages 2655–2669, <https://doi.org/10.1093/brain/awy206> (Impact factor 10.84)

Congress posters/abstracts:

3. A.L. de Almeida Marcelino, A.A Kühn, P. Krause, W.- J. Neumann, EP 1. The effect of subthalamic deep brain stimulation on impulsivity in Parkinson's disease patients, *Clinical Neurophysiology*, Volume 127, Issue 9, 2016, Page e175, ISSN 1388-2457, <https://doi.org/10.1016/j.clinph.2016.05.197> (Impact factor 3.614)

4. A.L. Marcelino, A. Horn, A. Kühn, W.J. Neumann. Subthalamic neuromodulation restores motor learning in Parkinson's disease [abstract]. *Mov Disord*. 2018; 33 (suppl 2). <https://www.mdsabstracts.org/abstract/subthalamic-neuromodulation-restores-motor-learning-in-parkinsons-disease/>. Accessed June 12, 2019. (Impact factor 7.072)

5. A.L. de A. Marcelino, A. Horn, P. Krause, A. Kühn, W.-J. Neumann, Subthalamic neuromodulation improves short-term motor learning in Parkinson's disease; abstract from "63. Jahrestagung der Deutschen Gesellschaft für Klinische Neurophysiologie und funktionelle Bildgebung (DGKN)", to be published in *Clinical Neurophysiology*.

Acknowledgements

I would like to thank Prof. Andrea Kühn for introducing me to the world of movement disorders and for all the guidance throughout these years with an excellent balance between being demanding, strict and fair.

To the same extent, I would like to thank Wolf-Julian Neumann for the direct supervision, which could not have been better. Julian was always ready to exchange thoughts and knowledge, give some advice when needed and, all this, always with a good smile and sense of humour. It was inspiring to work with such an intelligent person and I am extremely grateful for having learnt so much from him.

To both and to all the colleagues in the working group: I am thankful to be surrounded by such motivated and bright researchers that always show great respect for each other's work.

In addition, I must thank all patients and participants who were willing to take their time for science and, especially, for this project!

Last, but not least, I am very grateful to my family (Mãe, Pai e Janas!) for always being on my side, as well as Moritz for being unconditionally patient and supportive. Also, thank you to my very good and loyal friends who have kept me happy and motivated throughout this journey.

Obrigada!