

PROCEEDINGS OF SPIE

[SPIDigitalLibrary.org/conference-proceedings-of-spie](https://spiedigitallibrary.org/conference-proceedings-of-spie)

Design evolution of the Giant Magellan Telescope Integral Field Spectrograph, GMTIFS

Sharp, R., Adams, D., Bloxham, G., Boz, R., Bundy, D., et al.

R. Sharp, D. Adams, G. Bloxham, R. Boz, D. Bundy, D. Chandler, G. Gausachs, L. Gers, J. Hart, N. Herral, J. Nielsen, E. O'Brien, C. Onken, I. Price, A. Vaccarella, C. Vest, P. Young, "Design evolution of the Giant Magellan Telescope Integral Field Spectrograph, GMTIFS," Proc. SPIE 10702, Ground-based and Airborne Instrumentation for Astronomy VII, 107021V (6 July 2018); doi: 10.1117/12.2313010

SPIE.

Event: SPIE Astronomical Telescopes + Instrumentation, 2018, Austin, Texas, United States

Design evolution of the Giant Magellan Telescope Integral Field Spectrograph, GMTIFS

R. Sharp^{*a}, D. Adams^a, G. Bloxham^a, R. Boz^a, D. Bundy^a, D. Chandler^a, G. Gausachs^a, L. Gers^a, J. Hart^a, N. Herrald^a, J. Nielsen^a, E. O'Brien^a, C. Onken^a, I. Price^a, A. Vaccarella^a, C. Vest^a, P. Young^a,

^a Research School of Astronomy & Astrophysics, The Australia National University, ACT 2611, Australia

ABSTRACT

We report the design evolution for the GMT Integral Field Spectrograph, (GMTIFS). To support the range of operating modes – a spectroscopic channel providing integral field spectroscopy with variable spaxel scales, and a parallel imaging channel Nyquist sampling the LTAO corrected field of view - the design process has focused on risk mitigation for the demanding operational tolerances. We summarise results from prototype components, confirming concepts are meeting the necessary specifications. Ongoing review and simulation of the scientific requirements also leads to new demonstrations of the science that will be made possible with this new generation of high performance AO assisted instrumentation.

Keywords: GMT, near-infrared, adaptive optics, integral-field spectroscopy

1. INTRODUCTION

GMTIFS is the first generation near-infrared ($\lambda \sim 1\text{-}2.5\mu\text{m}$) AO assisted integral field spectrograph and imager for the GMT. It is based on the concentric image slicer design developed for the Gemini/NIFS instrument[1], with an additional imaging arm capable of simultaneous observations in complementary pass bands. GMTIFS[2,3] is envisaged as a workhorse instrument, providing high-quality medium-resolution spectroscopy and imaging across a wide range of primary science cases. The instrument, currently in the preliminary design phase, is conceptually constructed from a number of optical building blocks as described below and shown graphically in Figure 1.

Structurally, the instrument is designed around a large central optical table that provides a rigid framework to control differential flexure between the cryogenic optical components. The optical layout is shown in Figure 2 and the baseline mechanical layout in Figure 3. Trade studies considering fabrication techniques for this optical *cold work surface*, and for the outer cryostat, are reported below.

1.1 External wavefront sensors

The GMT NGSAO and LTAO systems are primarily driven by two sets of sensors mounted to the front of the GMTIFS cryostat. These sensors use the optical light ($\lambda < 1\mu\text{m}$) reflected from the cryostat front window. The external wavefront sensors do not provide a stable Tip-Tilt reference, due to the mechanical disconnect from the science instrument, hence this term will be provided from an On-Instrument Wavefront Sensor internal to GMTIFS. The external wavefront sensors are not part of the GMTIFS project and are under design by other instrument teams from across the GMT collaboration.

* Rob.Sharp@anu.edu.au; +61 (0)2 6125 8035

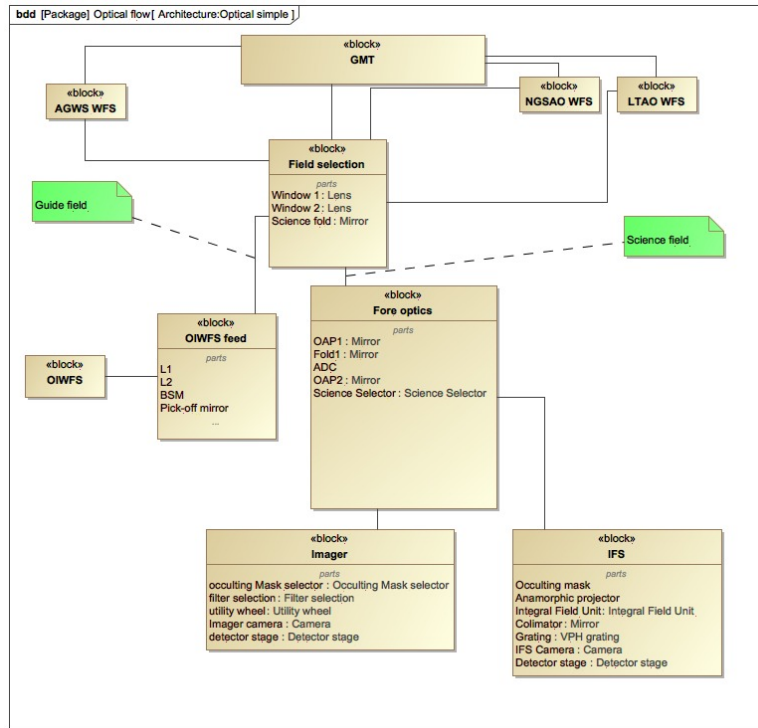

Figure 1: The optical system architecture is captured in the structural block diagram. Components external to the GMTIFS project, such as the various wavefront sensing systems, are shown to provide context. The optical layout is shown in Figure 2 and the baseline mechanical layout in Figure 3.

1.2 On-instrument wavefront sensor

The OIWFS system is principally responsible for providing the precession tip-tilt reference relative to the science arms of GMTIFS. As such it will be mounted directly to the cold work surface optical table. The OIWFS is fed by the GMTIFS Beam Steering Mirror system (BSM [4,5]). The BSM provides access to tip-tilt guide stars from across the full 180 arcsec guide field, ensuring high sky coverage for the LTAO observing mode. It also provides the precession offset guiding reference for on-source dithering and accurate source acquisition via blind offset from reference sources.

While the OIWFS optical feed (BSM and relay optics) are fundamental components of the GMTIFS preliminary design study, the WFS optics are not at this time. Evolution of the technical requirements of the OIWFS system with respect to the GMT AO systems, coupled with the emergence of electron Avalanche Photo Diode detectors (eAPD, i.e., the SAPHIRA detector from Leonardo – [6,7] dictate that the base line design for this system be revisited[8].

1.3 Instrument fore-optics

The fore-optics provide the pupil image relay necessary to form the instrument cold stop and provide a collimated beam for the Atmospheric Dispersion Corrector. The last element in this subsystem is the Science Selector, a rotating turret housing a suite of dichroic beam-splitters that are used to separate the Imager and IFS fields in wavelength (providing order sorting, and simultaneous out-of-band imaging/spectroscopy). Accurate and repeatable alignment of this element is a significant challenge and hence has been the focus of prototyping efforts (see below [9]).

The first element in the GMTIFS optical train, the cryostat front window, also mounts the dichroic coating to feed the external wavefront sensors. This tilted window is paired with a counter tilted window to remove the induced astigmatism[10] however some residual longitudinal colour remains in the fore optics design. Such residuals are currently handled within the six element Atmospheric Dispersion Corrector. However, risk mitigation during PDR development suggests the large (300 mm diameter) Calcium Fluoride elements can be replaced with infrared fused silica if an independent two element colour corrector is introduced at the ADC. This also results in simplification of the ADC design and so the alternative design suffers little global performance degradation.

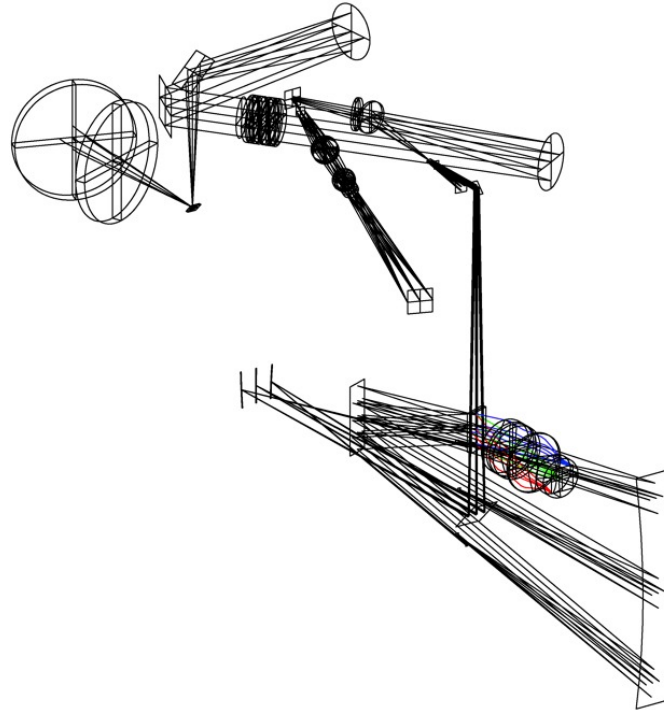

Figure 2: The baseline folded optical design for GMTIFS is split across the three layers of the optical table cold work surface. The fore optics, and Imager occupy the upper chamber, with the majority of the IFS system in the lower chamber. The central chamber houses the OIWFS feed and BSM (not shown).

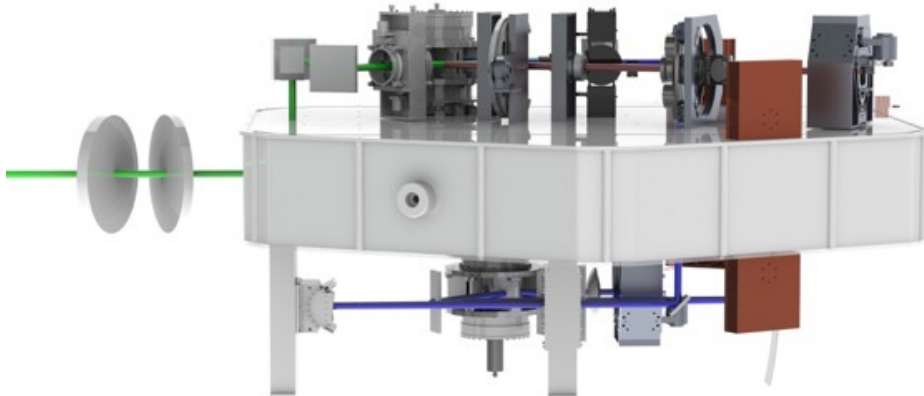

Figure 3 A simple solid rendering of the GMTIFS cold work surface optical table is shown with the GMTIFS optical components mounted in place. The two element cryostat front window is shown without mechanical support, and the majority of internal support structure and baffling is not included.

1.4 Imager arm

The GMTIFS imager uses a single monolithic Teledyne Hawaii H4RG-15 μ m detector, operating with 5 mas pixels to sample the *J*-band diffraction limit, providing a field of view of $\sim 20 \times 20$ arcsec. It is believed that this field size is well matched to the corrected field of view of the LTAO system. The imager arm provides scientific imaging through a range of optical filters (two 10-slot filters wheels in a tandem arrangement are proposed, allowing 16 independent filter positions once *blocking* and *clear* apertures are accounted for). The Imager will also provide a Tip-Tilt OIWFS mode in some AO configuration (via on-detector guide window readout). The Imager is an invaluable tool as an acquisition camera for GMTIFS.

As well as science filters, the Imager optical train also contains:

- A four-position utility wheel housing
 - A clear port
 - Optics to allow pupil viewing for alignment
 - A set of focal retarder/extender lenses (2 positions) to allow non-common path WFE determination via the Roddier principle (as used for Gemini/NIFS).
- A coronagraphic mask system
 - To provide basic coronagraph capability. This mode has proved to be valuable for the Gemini/NIFS system and is provided at minimal additional instrument cost. We stress however that GMTIFS is not optimized for coronagraphic operations, and it is acknowledged that this mode is sub-optimal for that purpose.

1.5 Integral Field Spectrograph

The image slicer spectrograph design, based in the Gemini/NIFS heritage, is the principle science arm of the instrument. The Spectrograph has a single monolithic focal plane array using a Teledyne Hawaii H4RG-15 μ m detector. A series of four interchangeable field projectors provide a choice of plate-scales

for a common slicer format of 45 slices by 90 spatial elements long. The instrument uses anamorphic projection to deliver “square pixels on the sky”, avoiding oversampling the slit spatial dimension. The interchangeable format is necessary to provide Nyquist sampled Integral Field Spectroscopy at the AO diffraction limit as well as a larger angular scale mode delivering high ensquared energy to maximize sensitivity for low surface brightness sources.

The fixed format camera/collimator is not articulated, but does employ interchangeable VPH gratings, operating in the Littrow configuration, to deliver spectroscopy over the spectral range $\lambda \sim 1\text{-}2.5\mu\text{m}$ in three separate wavelength settings (punctuated by the atmospheric water absorption bands).

A medium spectral resolution mode of $R \sim 5,000$ is adopted, well matched to the H4RG format and providing sufficient resolution to work between the strong OH airglow night-sky lines. A second suite of high resolution, $R \sim 10,000$, is available using VPH grisms to maintain the fixed camera/collimator angle with these higher resolution gratings (as implemented in the ANU WiFeS spectrograph[11]). As with the Imager arm, the IFS also contains a series of occulting masks to allow basic coronagraphic operation.

2. KEY OPERATIONAL CONCEPTS

The GMTIFS instrument implements a number of design philosophies that underpin the current optical design.

2.1 Spatial split for guide field.

When operating in LTAO mode GMTIFS achieves a high sky coverage by accessing the *full* 180 arcsecond diameter technical field delivery by GMT to the folded-port foci. A suitable guide star can be identified from anywhere within this field of view, with the exception of the $\sim 20 \times 20$ arcsec central science field which is folded out at the first focus within GMTIFS. This spatial split results in the full near-infrared spectrum being available for wavefront sensing. Rather than adopting the deployable probe arm approach to guide star pick-off, GMTIFS implements a novel approach using a beam steering mirror to select a small region of interest from the full field and to relay this to the OIWFS.

2.2 Parallel operations

The interchangeable science selector dichroic provides order sorting wavelength selection for the IFS in reflected light while allowing the complementary pass-bands to be observed in parallel with the Imager arm.

3. UPDATED PERFORMANCE SIMULATIONS

As the instrument design progresses, the transmission budget and scientific exposure time calculators (for IFS and Imager modes) have evolved to reflect the current design specification. Simple rapid analysis calculators are provided at:

<https://www.mso.anu.edu.au/gmtifs/Performance/GMTIFS-IFS-ETC.shtml>

<https://www.mso.anu.edu.au/gmtifs/Performance/GMTIFS-Imager-ETC.shtml>

A more complex system for the full simulation of scientific observations, from the raw detector data level, through pipeline processing to produce *publication ready* data, is maintained as an active part of the system requirements analysis process. An example of the simulator output for the Imager system is shown in Figure 4 along with results modified to represent contemporary facilities.

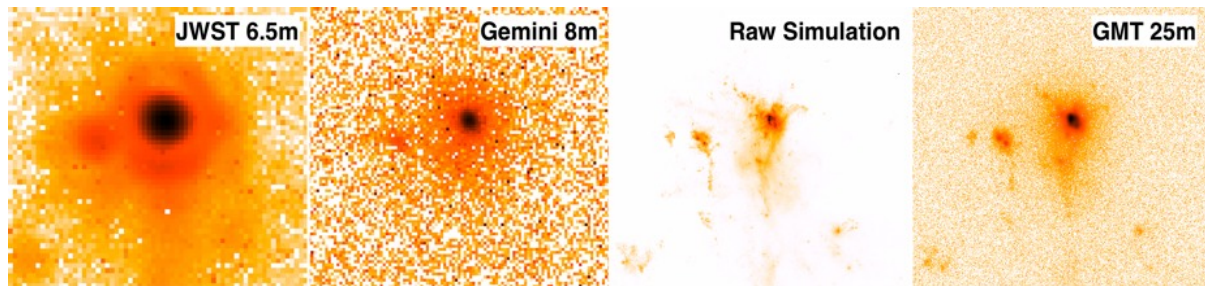

Figure 4: Science simulator data product example. The GMT combined with adaptive optics (AO) will resolve structural details on scales of 200-500 pc. Each panel shows an image of a star-forming galaxy at $z = 8$ from the FIRE simulation[12] for an $m_{AB} = 23$ galaxy with resolved clumps of star-formation. Each panel is $1.4'' \times 1.2''$ (physically about 7 kpc x 6 kpc). The right-middle panel shows the native simulation. The other panels show the 2 micron images available from 30 h exposures with the JWST, the Gemini telescope (GeMS), and the GMT (GMTIFS+LTAO). The GMT will resolve the detailed structures and give an accurate picture of how star-formation occurs in these most distant galaxies for the first time.

4. FABRICATION TRADE STUDIES

Key elements of the structural design have been the subject of trade studies as part of the preliminary design study. The designs have been considered not only for utility against their design requirements but also their suitability for fabrication.

4.1 Instrument cold work surface optical table

The cold work surface structure includes the central optical table and surrounding radiation shielding. The optical table consists of a hexagonal table 1,800 mm across flats and 300 mm thick. A partial cutaway view of the table is shown in Figure 5. The table is designed to be produced via machining from two halves. A consideration for manufacturing was the truss mounts, which distribute loads from the hexapod support structure to the internal table structure, as these must provide significant bending strength at the table mid-plane. The adopted design uses easily machined cylindrical structures that join to the outside face and reinforced internal node. Machining the table from large billets was selected as the preferred process due to the favorable combination of control over material properties, design freedom, and industrial capability. Other production methods considered included welding the internal structure from plates, and wire-EDM cutting the internal web structure and fastening it to solid outer faces. Due to the large size the table will be machined from 5083 Aluminium as opposed to the 6061-T6 Aluminum used for other components. The two materials have similar coefficients of thermal expansion, within the stated tolerance for variation.

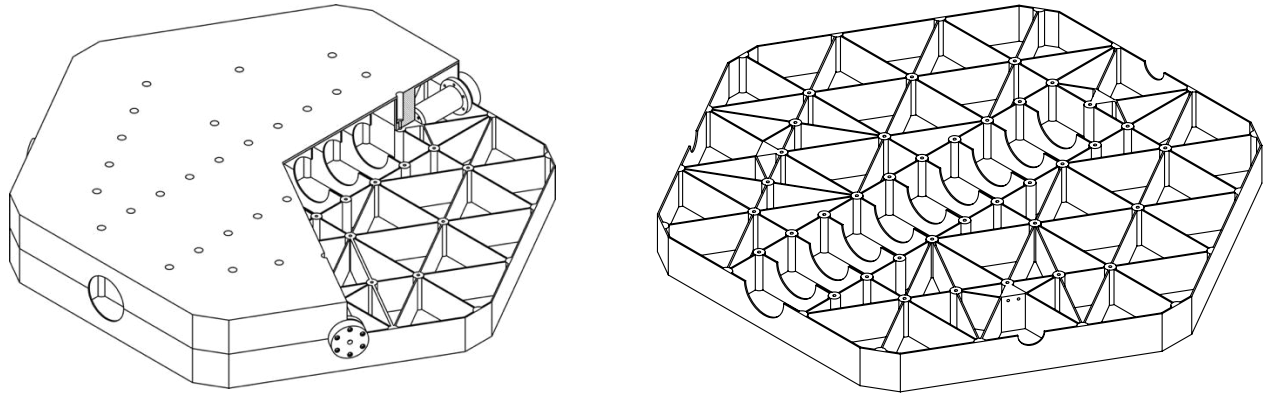

Figure 5: Optical table is designed to be fabricated in two halves, machined from individual billets.

The optical table is designed to minimize deflection under self-weight, as stiffness in the vertical direction drives vertical decentre during pointing. The table displacement during zenith pointing is shown in Figure 6. Flatness change due to deflection was found to be of the order of $1\ \mu\text{m}$. An initial component-by-component FEA model is under development to quantify flexure under the varying gravitational load for instruments mounted in the GMT Gregorian Instrument Rotator platform.

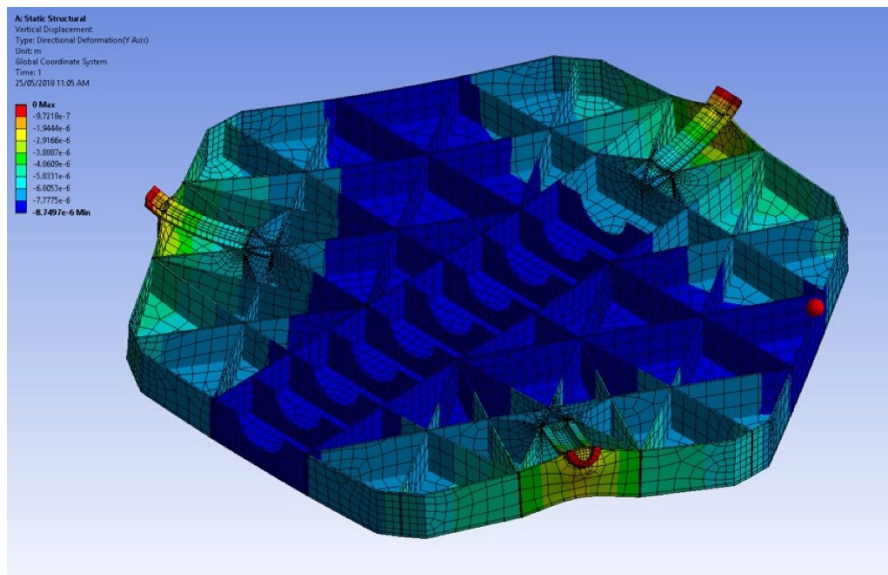

Figure 6: Flexure modeling of the cold work surface optical table confirms axial symmetry of deflection and optical decenter. Ongoing FEA will trace differential flexure between optical components as the mechanical design solidifies around the final optical design.

4.2 Cryostat

The GMTIFS cryostat, shown in Figure 7, consists of a cylindrical main chamber with domed end-caps, all produced from 2205 duplex stainless-steel. Stainless-steel was selected over Aluminum primarily because of the ease of welding and wide industrial capability for forming and fabricating vacuum chambers using this material. The stainless-steel construction also offers the ability to use COTS fittings and flanges, simplifying construction. The cylindrical design offers an efficient pressure

structure, allowing for thinner material and simpler fabricating methods compared to the earlier hexagonal baseline[2]. To achieve specifications for thermal background emission and mechanical stability, the cold work surface will operate at 100K with $\pm 0.1K$ stability.

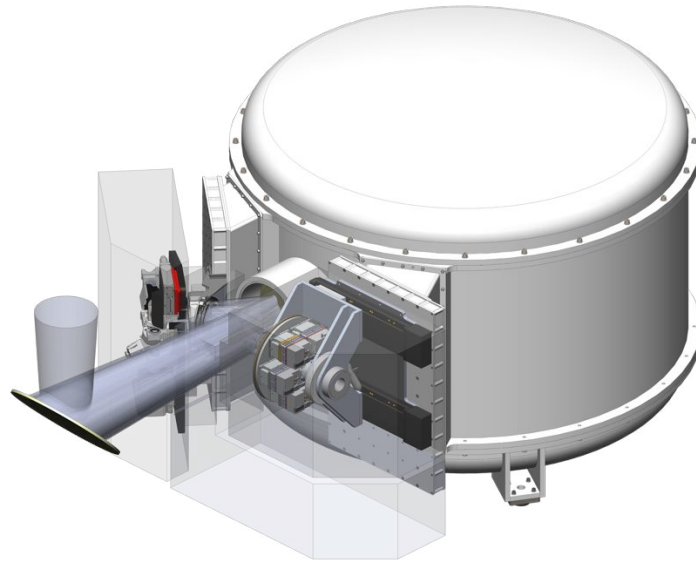

Figure 7: GMTIFS cryostat design concept. The incoming light from the GMT tertiary mirror is shown, as are the LTAO and NGAO wavefront sensors, mounted to the front of the cryostat.

The central cylindrical section of the cryostat will be made from rolled stainless steel sheet, joined to make a cylinder. Ports and windows are then welded into place. The recommended thickness for this shell is 6 mm. The basic layout of this design is shown in Figure 7. The end-caps will be stainless steel design and of torispherical shape. After forming, a flange is welded to the periphery of the end-cap. The torispherical end-cap design was selected due to efficient load distribution and wide industrial capability.

An advantage of the Stainless-steel design is the ability to easily integrate the cryostat structure into surrounding support equipment. A handling cart is integrated into the bottom end-cap, distributing loads effectively while minimizing the overall height of the cryostat as much as possible. This end cap and cart assembly is shown in Figure 9.

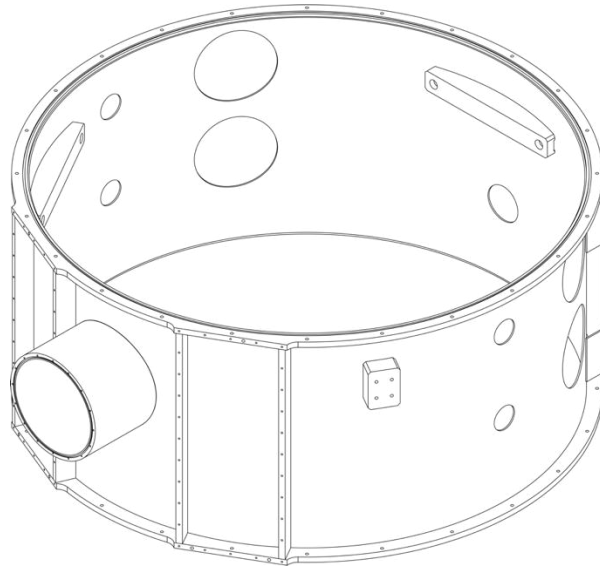

Figure 8 Current cryostat layout with mountings for fixtures and fittings.

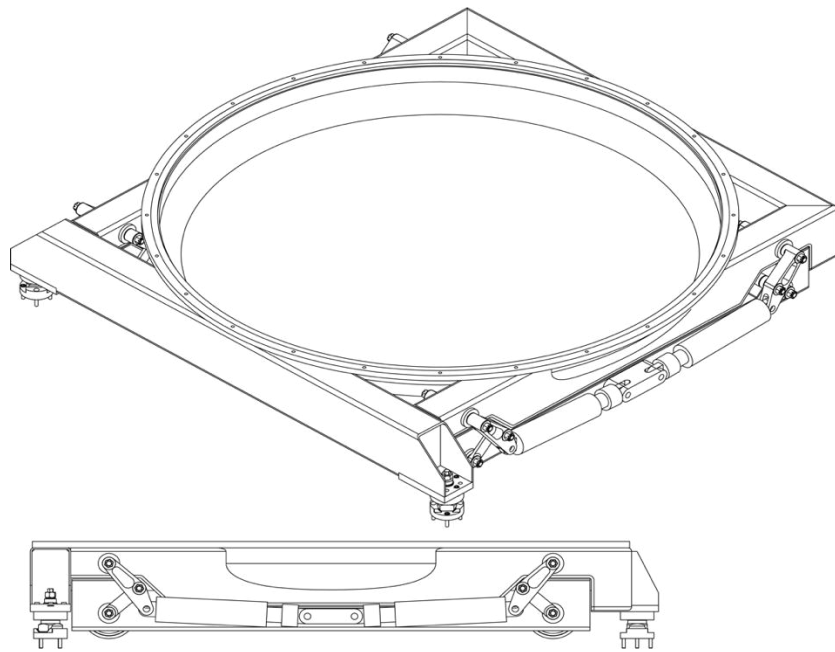

Figure 9: Bottom end-cap and integrated handling cart.

5. PROTOTYPING

The demanding requirements on position and repeatability tolerances for AO assisted instrumentation on extremely large telescopes dictates that critical mechanisms are prototyped to ensure sufficient accuracy is delivered. The initial prototyping effort focused on the Beam Steering Mirror (BSM) assembly used as part of the OIWFS feed[4,5]. The next concept selected for prototype activity is rotary mechanism control and encoding. The current design concept requires a number of precision rotary mechanisms and a common sensing geometry has been adopted based in sensing the varying gap between the outer radius of an off-center circular disc and a precision capacitive sensor head[9]. The common geometry has been specified for all rotary systems (indeed the analogous sensor system and geometry is also proposed for linear stages using a wedged target) and a hybrid prototype system developed to confirm sensor and encoder performance in the cryogenic environment. This hybrid is shown in Figure 10 undergoing initial warm laboratory testing. The most demanding rotary element of the GMTIFS design is the *science selector* turret which supports the dichroic mirrors that split the science field light between the Imager and IFS depending on the dominant science mode in use. The necessary alignment of the reflected beam into the IFS feed required a setting repeatability of the order 5.5" to ensure repeatability of a science targets location in the IFS field of view between instrument reconfigurations.

The test rig is currently undergoing preparations for cryogenic testing, warm operations having demonstrated the demanding sensing requirement can be achieved with the current design concept. Interestingly, the warm laboratory testing highlighted the precision temperature stability control required for the system to achieve its design specification, with thermal expansion of the target ring system dictating thermal control to better than 1 K. While this level of stability proved to be genuinely challenging in the mechanical process laboratory over the extended time periods used for initial verification, it is consistent with the thermal environment requirements placed upon GMTIFS when in operation.

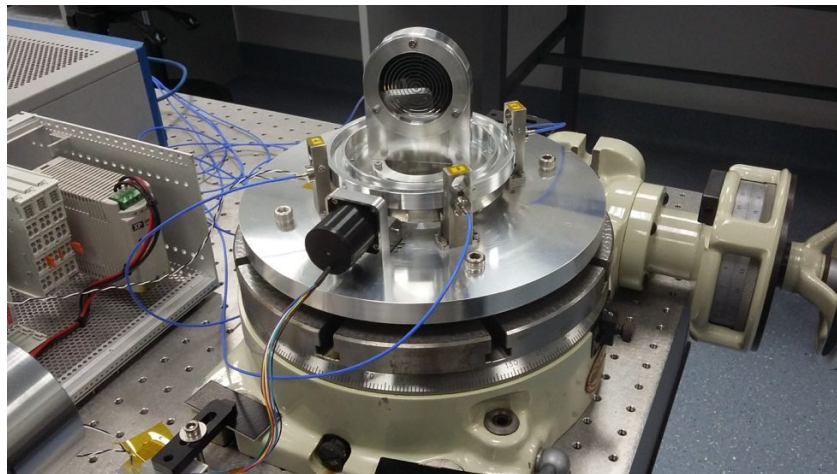

Figure 10: The laboratory test rig used to demonstrate the performance of the rotary encoding system proposed for many GMTIFS mechanisms is shown equipped with the optical target that provides feedback on the true position angle of the system during testing of the capacitive sensor components.

6. DETECTOR SYSTEMS

GMTIFS is designed around two large format, large pixel, near-infrared detectors. The Teledyne Hawaii H4RG-15 μ m was identified early in the Conceptual design study as the detector of choice due to the Hawaii detector design heritage and performance. While the Imager arm can accommodate smaller detector pixels (e.g., those of the Hawaii H4RG-10 μ m devices), the large spaxel scale of the IFS in low surface brightness high ensquared energy mode (50 mas per spaxel) would require an exceedingly fast camera. Recent announcement of the performance specifications and product availability for the Hawaii H4RG-15 μ m alleviates some of the program risk associated with retaining the largely pixel device at the heart of the IFS design.

For the OIWFS, the emerging electron Avalanche Photo Diode (eAPD) technology (specifically the SAPHIRA[13,14,15] detector from Leonardo) presents important new opportunities that require a re-evaluation of the system concepts and exploration of the capabilities of the new technology. As part of a parallel technology development program funded in partnership with GMTO, the Australian Research Council, and the ANU, we have developed an in-house system for testing and evaluation of the SAPHIRA against the GMTIFS OIWFS requirement[6]). The program is still in its infancy, but component testing in the observatory environment (in partnership with the University of Hawaii[7]) has shown promising results.

7. CONCLUSION

The GMTIFS project is progressing towards a Preliminary Design Review in December 2018. While the demanding instrumentation requirements faced by an adaptive optics integral field spectrograph remain challenging, ongoing prototyping effort, supported by careful systems engineering backed-up with detailed scientific and technical analysis, will ensure the Giant Magellan Telescope achieves its scientific objectives at the new frontiers opened up by extremely large telescopes in the coming decade.

REFERENCES

- [1] Hart, J., McGregor, P.J., Bloxham, G.J., "NIFS concentric integral field unit", Proc. SPIE, 4841, 319 (2003)
- [2] McGregor, P.J., Bloxham, G.J., Boz, R., et al., "GMT integral-field spectrograph (GMTIFS) conceptual design", Proc. SPIE, 8446E, 1, (2012)
- [3] Sharp, R., Bloxham, G., Boz, R. et al., "GMTIFS: The Giant Magellan Telescope integral fields spectrograph and imager", Proc. SPIE, 9908E, 1, (2016)
- [4] Sharp, R., Boz, R., Hat, J., et al., "The adaptive optics beam steering mirror for the GMT Integral-Field Spectrograph, GMTIFS", Proc. SPIE, 9151E. 0CS, (2014)
- [5] Davies, J., Bloxham, G., Boz, R., et al., "GMTIFS: the adaptive optics beam steering mirror for the GMT integral-field spectrograph", Proc. SPIE, 9912E, 17, (2016)

- [6] Vacarella, A., Sharp, R., Ellis, M., et al., “Cryogenic Detector Preamplifier Developments at the ANU”, Proc. SPIE, 10709, 27, (2018)
- [7] Goebal, S.B., Hall, D.N.B., Jacobson, S., et al., “Commissioning of cryogenic preamplifiers for SAPHIRA detectors”, Proc. SPIE, Proc. SPIE, 10709, 27, (2018)
- [8] Conan, R., Bennet, F., Bouchez, A.H., et al., “The Giant Magellan Telescope laser tomography adaptive optics system”, Proc. SPIE, 8447E, 3, (2012)
- [9] Price, I., Hart, J., O’Brien, E., et al., “Testing a prototype rotary mechanism for GMTIFS”, Proc. SPIE, 10706, 134, (2018)
- [10] Hart, J., Bloxham, G., Boz, R., Espeland, B., Sharp, R., “GMTIFS: challenging optical design problems and their solutions for the GMT integral-field spectrograph”, Proc. SPIE, 9908, 9, (2016)
- [11] Dopita, M.A., Waldron, L.E., McGregor, P., et al., “WiFeS: the wide field spectrograph”, Proc. SPIE, 5492, 262, (2004)
- [12] Ma, X., Hopkins, P.F., Boylan-Kolchin, M., et al., “Simulating galaxies in the reionization era with FIRE-2: morphologies and sizes”, 477, 219, (2018)
- [13] Atkinson, D., Hall, D., Baranec, C., Baker, I., Jacobson, S., Riddle, R., “Observatory deployment and characterization of SAPHIRA HgCdTe APD arrays”, Proc. SPIE, 9154, 19, (2014)
- [14] Finger, G., Baker, I., Alvarez, D., et al., “Sub-electron read noise and millisecond full-frame readout with the near infrared eAPD array SAPHIRA”, 9909, 12, (2016)
- [15] Greffe, T., Feautrier, P., Gach, J.-L., et al., “C-RED One : the infrared camera using the Saphira e-APD detector”, Proc. SPIE., 9907, 2, (2016)