

The Effects of Deception on Pacing Strategy, Perceptual Responses and Performance during Cycling Time Trials

Hollie S. Jones

A thesis submitted in partial fulfilment of the requirements of
Edge Hill University for the degree of
Doctor of Philosophy

February 2015

Abstract

The regulation of work-rate during self-paced exercise has become a favoured topic in exercise sciences in the mechanistic investigation of fatigue. Deception has emerged as a common, practical strategy which involves the manipulation of key variables during exercise. The intentions of deception studies have typically been to explore the mechanisms of pacing behaviour and to investigate the practical implications for athletic performance. A lack of experimental consideration, however, has pertained to the importance of perceptual experiences within exercise regulation and deception research. The purpose of this research was to examine the interaction of perceptual and performance responses in self-paced cycling time trials (TT), and the effects of deception on these responses. Study 1 examined pacing strategy and the associated changes in perceptual and physiological responses during both 16.1 and 40 km cycling TTs. The work demonstrated that affect was strongly negatively associated with power output, more significantly so in a 16.1 than a 40 km TT. Studies 2 and 3 adopted deceptive strategies, using cyclists' knowledge of their own previous performance, to explore the importance of these beliefs on pacing behaviour and perceptual experiences during 16.1 km TTs. This was achieved by manipulating the visual feedback of an avatar which depicted the cyclists' previous TT performance. Prior research has most commonly explored the acute effects of deceptive exposures, therefore these studies were designed to examine both acute and residual effects. The findings support the acute facilitative effects of visual feedback on performance outcomes, but did not demonstrate an influence of deception. Furthermore, no residual performance effects were evidenced, as the improvements in performance were not sustained in a subsequent TT. These studies provide a novel insight into the effects of this feedback provision on perceptual experiences during self-paced endurance exercise. They demonstrate that affect, perceived exertion and self-efficacy are differentially influenced by the nature of the feedback provided and are therefore important constructs to consider in future research in this area.

Key words: Deception, feedback, previous performance, pacing, affect, exertion, beliefs, time trial

Acknowledgements

There are numerous people that I would like to take this opportunity to sincerely thank for supporting me through this PhD and making the whole thing possible.

Firstly, I'd like to thank each of my supervisors, Dr David Marchant, Dr Craig Bridge, Professor Adrian Midgley and Professor Lars Mc Naughton. From the moment I stepped foot into the department at Edge Hill, right through to the final few weeks, your support, faith and encouragement have guided me through the most rewarding and challenging experience of my life. I am grateful for your relentless patience, expert advice and personal support to help me develop as an academic.

My gratitude extends to each and every cyclist who (most of the time) willingly rolled into the lab at all of hours of the day to perform endless time trials. A special thank you goes to those guys who kept coming back for more and making those long hours enjoyable by being so friendly and as enthusiastic about numbers as me. I didn't expect to make as many friendships along the way.

Thank you to all my colleagues at Edge Hill, especially my fellow PhD students Rick Page, Chris Brogden and Laura Houghton. I couldn't have wished to share that purple office with a better group of people. From experiencing the highs and lows, inventing weird and wonderful ways to procrastinate and rescuing each other from the setbacks, you've each helped me more than you'll know.

To my mum, dad, sister and brother; thank you for the unquestionable support, phone calls and Blackpool escapes. I wouldn't be in this position at all if you hadn't have always believed in me and inspired me to always challenge myself. To my best friends and personal cheerleaders, Lily and Jasmine, thank you for never failing to provide chocolate and wine for celebrations, commiserations or just Saturdays. I have never once doubted your faith in me to do this. To Dave, who has pushed me through the hardest months with unrelenting optimism, love and support, thank you for giving me so much to look forward to on the other side. I hope I have made you all proud.

And lastly, to my partner in crime, my flatmate, my best friend. Emily, I couldn't imagine going through this process without you by my side each step of the way. From losing our sanity on many occasions, crying on each other an unhealthy amount and laughing until our cheeks hurt, I'm so happy we both made it to the finish line together. I don't think many people could spend every waking hour of the day with someone the way we did, but we made it. Thank you for putting up with me.

Contents

List of Tables.....	1
List of Figures	2
List of Abbreviations and Symbols	3
Chapter 1 <i>Introduction and Review of Literature</i>	4
1.1 Introduction.....	5
1.1.1 The Central Governor Model	7
1.1.2 The Psychobiological Model.....	9
1.1.3 Summary	10
1.2 Deception	11
1.2.1 Endpoint Manipulation	17
1.2.2 Manipulation of Performance Feedback	19
1.2.3 Qualitative Feedback Manipulations	24
1.3 Summary and Limitations.....	25
1.3.1 Exercise Mode Limitations	26
1.3.2 Mechanistic Considerations	27
1.4 Aims of the Research.....	29
Chapter 2 <i>General Methods</i>	31
2.1 Introduction.....	32
2.2 Participants.....	32
2.3 Informed Consent and Ethical Approval	33
2.4 Experimental Conditions	34
2.5 Control Measures	34
2.6 Anthropometry.....	35
2.7 Maximal Incremental Test.....	35
2.8 Familiarisation Trials.....	36
2.9 Experimental Procedures and Apparatus	36
2.9.1 Cycling Time Trials.....	36
2.9.2 CompuTrainer Ergometer	37
2.10 Measurement Techniques	40
2.10.1 Perceptual Responses	40
2.10.2 Physiological Variables	42
2.11 Statistical Analysis.....	44

Chapter 3	<i>Distance-dependent Association of Affect with Pacing Strategy in Cycling Time Trials</i>	46
3.1	Introduction	47
3.2	Methods	50
3.2.1	Participants	50
3.2.2	Maximal Incremental Test	51
3.2.3	Research Design	51
3.2.4	Experimental Trials	52
3.2.5	Statistical Analysis	53
3.3	Results	54
3.3.1	Associations with Power Output Distribution	57
3.3.2	Relationship between P-RPE and TEA	58
3.4	Discussion	59
3.5	Conclusion	63
Chapter 4	<i>Deception has no Acute or Residual Effect on 16.1 km Cycling Time Trial Performance but Negatively Effects Perceptual Responses</i>	64
4.1	Introduction	65
4.2	Methods	67
4.2.1	Participants	67
4.2.2	Research Design	68
4.2.3	Experimental Trials	69
4.2.4	Statistical Analysis	70
4.3	Results	71
4.3.1	Performance Variables	71
4.3.2	Perceptual Responses	73
4.3.3	Physiological Variables	75
4.3.4	TT1-TT2	78
4.4	Discussion	78
4.5	Conclusion	82
Chapter 5	<i>Effects of Previous Performance Beliefs on Perceptual Responses and Performance in 16.1 km Cycling Time Trials</i>	83
5.1	Introduction	84
5.2	Methods	86
5.2.1	Participants	86

5.2.2	Research Design	87
5.2.3	Experimental Trials.....	88
5.2.4	Statistical Analysis	89
5.3	Results	90
5.3.1	Performance Variables.....	90
5.3.2	Perceptual Responses	92
5.3.3	Physiological Variables.....	93
5.3.4	TT1-TT2.....	96
5.4	Discussion	96
5.5	Conclusion	99
Chapter 6	<i>General Discussion</i>	100
6.1	Introduction.....	101
6.2	Realisation of the Research Aims	101
6.3	Main Discussion.....	103
6.3.3	Acute Effects	103
6.3.4	Summary	112
6.3.1	Residual Effects	113
6.3.2	Summary	118
6.4	Future Research Directions	118
6.5	Conclusion	123
References	126
Appendices	139

List of Tables

Table 1.1	Description and key findings of prior deception studies.....	12
Table 2.1	Criteria to classify cyclist’s performance level (PL).....	33
Table 3.1	Mean (SD) descriptive data for participant characteristics.....	51
Table 3.2	Mean (SD) heart rate, V_E , VO_2 and RER across distance quartile in 16.1 km and 40 km time trials.....	56
Table 3.3	Mean (SD) pre- and post-trial blood lactate and blood gas parameters in 16.1 km and 40 km time trials.....	57
Table 3.4	Median (IQR) within-subject correlation coefficients for the relationships between power output and all exploratory variables..	58
Table 4.1	Mean (SD) descriptive data for the CON _{FBL} and DEC experimental groups.....	68
Table 4.2	Mean (SD) performance and metabolite responses for the CON _{FBL} and DEC CON _{FBL} and DEC groups.....	72
Table 4.3	Mean (SD) physiological responses at each distance quartile in 16.1 km time trials for the CON _{FBL} and DEC groups.....	77
Table 5.1	Mean (SD) descriptive data for the CON ₁₀₂ and DEC _{kno} experimental groups.....	87
Table 5.2	Mean (SD) performance and metabolite responses for the CON ₁₀₂ and DEC _{kno} groups.....	91
Table 5.3	Mean (SD) physiological responses at each distance quartile in 16.1 km time trials for the CON ₁₀₂ and DEC _{kno} groups.....	95
Table 6.1	Between-group comparisons of the research designs and acute outcomes in the PACER trial.....	108

List of Figures

Figure 2.1	Representation of the visual feedback provided to participants during the PACER trial.....	40
Figure 3.1	Mean (SD) power output (A), affect (B), P-RPE (C) and TEA (D) across distance quartile in 16.1 km and 40 km time trials.....	55
Figure 3.2	Mean (SD) P-RPE and TEA responses across distance quartile in 16.1 km and 40 km time trials.....	59
Figure 4.1	Trial schematic of the research design for both CON _{FBL} and DEC groups.....	68
Figure 4.2	Mean (SEM) power output at each distance quartile in 16.1 km time trials for the CON _{FBL} and DEC groups.....	73
Figure 4.3	Mean (SEM) affect (A), RPE (B) and self-efficacy (C) responses at each distance quartile in 16.1 km time trials for the experimental groups.....	75
Figure 5.1	Trial schematic of the research design for both CON ₁₀₂ and DEC _{kno} groups.....	87
Figure 5.2	Mean (SEM) power output at each distance quartile in 16.1 km time trials for the CON ₁₀₂ and DEC _{kno} groups.....	92
Figure 5.3	Mean (SEM) affect (A), RPE (B) and self-efficacy (C) responses at each distance quartile in 16.1 km time trials for the CON ₁₀₂ and DEC _{kno} groups.....	93

List of Abbreviations and Symbols

CGM = Central Governor Model

CON = Control group

CON₁₀₂ = Control 102% group

CON_{FBL} = Control fastest baseline group

CV = Coefficient of variation

DEC = Deception group

DEC_{kno} = Deception with knowledge group

FBL = Fastest baseline trial

IQR = Interquartile range

MD = Mean difference

NSD = No significant difference

PACER = Trial with pacer

PO = Power output

P-RPE = Physical Ratings of Perceived Exertion

RER = Respiratory Exchange Ratio

RPE = Ratings of Perceived Exertion

SEM = Standard error of measurement

SD = Standard deviation

SUB = Subsequent trial

TEA = Task Effort and Awareness

TT = Time trial

V_E = Minute ventilation

VO₂ = Pulmonary oxygen uptake

VO_{2peak} = Peak oxygen uptake

Chapter 1

Introduction and Review of Literature

Parts of this chapter have been published in a peer-reviewed journal.

Jones, H.S., et al. (2013) Physiological and psychological effects of deception on pacing strategy and performance: A review. *Sports Medicine*, 43(12), 1243–57.

1.1 INTRODUCTION

Pacing strategies are often defined as the distribution of work-rate during exercise (Abbiss and Laursen 2008) and are widely accepted to be an important factor influencing overall athletic performance (Foster, Hoyos and Earnest 2005). Strategies are adopted during exercise to enhance performance whilst ensuring physiological limits are not surpassed (Hampson, St Clair Gibson and Lambert 2001). On the one hand, the ability to set and maintain an appropriate pacing strategy determines the successfulness of performance in a number of exercise modes, durations and intensities (Hettinga, de Koning and Hulleman 2012; de Koning, Foster and Bakkum 2011). However, on the other, pacing prevents a disproportionate distribution of resources that would result in premature fatigue and physiological failure (Noakes, St Clair Gibson and Lambert 2005).

Many studies investigating how fatigue limits performance are examples of muscle performance investigations, with fatigue typically defined as an 'exercise-induced reduction in maximal voluntary muscle force' (Gandevia 2001). Traditional peripheral and central fatigue theories attribute fatigue to the impairment of muscle contractility or reduction in central motor drive, respectively (Knicker, Renshaw and Oldham 2011). The experimental conditions under which these theories have been investigated have commonly lacked sufficient external validity (Boullosa and Nakamura 2013). Externally-driven laboratory tests using a motorised treadmill or fixed-resistance cycling ergometer, are considered 'brainless' as they make no allowances for participant-controlled adjustments in pace relative to the feedback available or the subjective sensations of fatigue experienced (Marino, Gard and Drinkwater 2012). Fatigue can exist without exhaustion as seen in voluntary paced exercise such as running races or cycling time trials (TT), where performance is time-based and success is determined by covering a set distance in the fastest time possible (Atkinson, Peacock and St Clair Gibson 2007). Fatigue in this type of exercise instead pertains to task failure at the point where the individual fails to maintain the desired work-rate and an optimal performance is not achieved (Hunter, Duchateau and Enoka 2004). The importance of pacing strategy in top-level cycling performance is widely acknowledged due to the small margin

between success and failure and/or first and second place (Hettinga et al. 2012; Atkinson et al. 2007). Competitive cycling events include criteriums, road races, TTs and track events where performance is often further influenced by factors such as bike handling skills, positioning, race tactics, drafting and the environment. Consequently, the sufficiency of studying fatigue as a closed feedback loop is challenged and the limitations of methodological designs that do not mimic the motor patterns that occur during sporting events have been acknowledged (Abbiss, Menaspá and Villerius 2013). Alternatively, research designs using highly motivated athletes and exercise protocols under real conditions are better suited to advance our understanding of fatigue in exercise regulation (Boullosa and Nakamura 2013). Namely, self-paced cycling TTs have often been the choice of modality within the pacing field (Tucker and Noakes 2009; Abbiss and Laursen 2008).

The exploration of pacing strategies in self-paced exercise can be addressed from two angles; how they are set prior to the commencement of exercise and how they are altered throughout the exercise. An initial work-rate is selected that is believed will allow the distribution and utilisation of all available physiological capacities over the duration of the exercise, but without exceeding these capacities and fatiguing prematurely (Renfree, Martin and Micklewright 2014). As no exercise bout will ever be performed in exactly the same physiological state or external conditions, continuous adjustments to work-rate must then be made throughout the exercise to ensure the selected pace remains optimal. A number of theories have been proposed to explain how pacing strategies are set and regulated (see review by Abbiss and Laursen 2008), but a lack of scientific consensus exists. Stemming from traditional central and peripheral theories of fatigue, more recent models such as the Central Governor Model (CGM) (Noakes and St Clair Gibson 2004; Noakes, Peltonen and Rusko 2001) and Psychobiological Model (Marcora 2008) offer alternative perspectives for the key regulatory mechanisms. Theories that adopt linear and reductionist approaches have been challenged in their ability to explain the multifaceted nature of fatigue (Laurent and Green 2009; Abbiss and Laursen 2008; Lambert, St Clair Gibson and Noakes 2005). Support for task dependency models (Knicker et al. 2011; Marino, Gard and Drinkwater 2011; Weir,

Beck and Cramer 2004) and for the interaction of multiple mechanisms, both peripheral and brain-centred in origin, instead provide a more holistic perspective of the phenomenon.

The relative importance of a number of mechanisms is disputed between each of these theories, with discourse surrounding the role of afferent feedback from peripheral muscles and interoceptive systems, as well as the significance of motivational, external factors (Marcora 2008). Previous experience and knowledge of the exercise endpoint are factors which are deemed essential in exercise regulation (Foster, Hendrickson and Peyer 2009; Hettinga, de Koning and Broersen 2006) and one mechanism these models all seem to consistently have in common is that of perceived exertion. The CGM (Noakes and St Clair Gibson 2004; Noakes, Peltonen and Rusko 2001), the Psychobiological model (Marcora 2008), and the Anticipatory Template model (Tucker 2009) amongst others all incorporate perceived exertion in their models and attribute alterations in work-rate to the rate of change of perceived exertion during exercise. The most common way of measuring whole-body perceptions of exertion is through Borg's (1970) Ratings of Perceived Exertion (RPE) scale, which measures the overall conscious perception of physiological, psychological, biomechanical and environmental pacing-related factors (Smits, Pepping and Hettinga 2014). Two key models of exercise regulation are subsequently discussed in further detail.

1.1.1 The Central Governor Model

The CGM (Noakes, St Clair Gibson and Lambert 2005; Noakes and St Clair Gibson 2004; St Clair Gibson and Noakes 2004) attributes changes in pace during exercise to a brain-derived regulatory strategy by a central governor in order to maintain an exercise reserve (Swart, Lamberts and Lambert 2009). Experience-primed feedforward control determines initial pace, incorporating knowledge of the exercise endpoint, previous experience of similar exercise bouts, internal physiological state (metabolic conditions) and external conditions (environment) (St Clair Gibson, Lambert and Rauch 2006). Oxygen saturation, glycogen levels and metabolic fuel reserves, for example, act not just as metabolic by-products, but as

internal signallers (Noakes, St Clair Gibson and Lambert 2005; Rauch, St Clair Gibson and Lambert 2005). On the other hand, environmental conditions such as gradient, terrain, weather, oxygen content of inspired air, knowledge of the event (for example distance or duration) (Ansley, Robson and St Clair Gibson 2004), previous experience (Micklewright, Papadopoulou and Swart 2010; Paterson and Marino 2004) and competition (Corbett, Barwood and Ouzounoglou 2012; Stone, Thomas and Wilkinson 2012) all equate to external cues (Faulkner, Arnold and Eston 2011; Tucker and Noakes 2009; St Clair Gibson et al. 2006). The interpretation of these cues by the central governor is used to determine the magnitude of efferent neural drive to the working muscles. This subconscious, feedforward integration process has been termed “teleoanticipation” (Ulmer 1996) and is a key element of the CGM (Lambert, St Clair Gibson and Noakes 2005).

One proposition of the model is that perceived exertion plays an anticipatory role in exercise regulation, as determined by changing patterns of physiological afferent feedback (Tucker 2009). It states that a ‘template RPE’ is set prior to the commencement of exercise, based upon the expected exercise duration and previous experience of similar bouts of exercise; two cues of teleoanticipation that are regarded as the most influential to pacing strategy. Therefore, from the onset of exercise, the selected work-rate is said to be moderated so that a maximal RPE will occur at the endpoint of the exercise. Disparity between experienced RPE and template RPE provokes a pacing modification to restore an appropriate RPE trajectory, which coincides with the exercise end-point (Faulkner and Eston 2008; Joseph, Johnson and Battista 2008; Eston, Faulkner and St Clair Gibson 2007; Noakes 2004). If the experienced RPE is too high, for example, the central governor would impose a reduction in neural drive so that a slower pace would cause RPE to be reduced and a maximal RPE is prevented from occurring before the exercise endpoint. The RPE template is set, not in accordance with the exercise intensity, but in relation to the exercise duration and to increase as a linear function of the percentage duration remaining (Noakes 2012; 2011) in such a way that the initial rate of increase can accurately predict the endpoint (Crewe, Tucker and Noakes 2008).

Further regulation of work-rate and the subsequent metabolic responses occurring throughout the exercise are said to be continuously adjusted as feedback control mechanisms relay information from physiological peripheral systems, which are integrated in relation to external feedback (St Clair Gibson et al. 2006; Albertus, Tucker and St Clair Gibson 2005). Throughout exercise, the integration of physiological afferent feedback and external performance feedback is compared to the template RPE and the remaining duration of the exercise at the current work-rate and a 'conscious RPE' is produced.

1.1.2 The Psychobiological Model

In opposition to a subconscious regulation of pace by a central governor in the brain, the Psychobiological Model (Marcora and Staiano 2010; Marcora 2008) attributes exercise regulation to conscious control processes. The model stems from motivational intensity theory (Wright 1996) and proposes that task disengagement, i.e. the reduction or termination of work-rate, will occur when one of two situations occur: when the maximum effort an individual is willing to exert is reached, or when the individual believes a true maximum effort has been exerted and further effort is perceived as impossible (Marcora 2008). Recent applications of decision-making theories also support this conscious control of pace and influential role of motivational factors (Renfree et al. 2014; Smits, Pepping and Hettinga 2014). Decisions made during athletic events are clearly integral to the successful adjustments to pace in order to perform optimally in relation to the task goals. Recent pacing studies have placed more emphasis on the importance of decision-making processes in self-paced exercise and have offered theoretical explanations for previous findings in this field of research (Smits, Pepping and Hettinga 2014; Renfree et al. 2014). Decision-making has been defined as 'the process of making a choice from a set of options where the consequences of that choice are crucial' (Renfree et al. 2014) or 'the capability of individuals to select functional actions to achieve a specific task goal from a number of action possibilities' (Smits, Pepping and Hettinga 2014). The theory of rational decision-making states that work-rate decisions are based on the availability and interpretation of information that will affect the outcome of the task (Renfree et al. 2014). Therefore, the information

that an athlete has access to during exercise will influence perceived exertion and decisions to maintain, increase or decrease work-rate. The current work-rate is interpreted in relation to the effect on future capacity to produce momentary sensations of fatigue (Smits, Pepping and Hettinga 2014). If the work-rate is deemed too high to sustain for the duration of the exercise based on the task goals, sensations of fatigue will worsen, acting as a conscious restrainer of intensity (Smits, Pepping and Hettinga 2014). As pacing decisions are based on the willingness to tolerate discomfort, an athlete's ability to persevere in situations of increased fatigue sensations, particularly during high intensity exercise, is likely to be crucial to pacing (Smits, Pepping and Hettinga 2014). This resonates with the existence of a psychological, as well as a metabolic, reserve capacity that limits exercise performance (Baron, Moullan and Deruelle 2011).

1.1.3 Summary

The resultant pacing strategy employed during exercise results in motor unit and metabolic reserves that are preserved in order to prevent a catastrophic physiological failure (Stone et al. 2012). Therefore an athlete's absolute physiological capabilities are not reached and performance is thus not representative of a true maximal effort. The need for evidence to support the existence of metabolic and psychological reserves at the completion of exercise consequently provides a rationale for the investigation into how these reserves can be accessed (Swart et al. 2009; Swart, Lamberts and Lambert 2009b; St Clair Gibson, Schabort and Noakes 2001). Obtaining an effort that is closer to maximal by tapping into an athlete's true physiological capabilities and surpassing psychological limits is of interest in order to help validate the model, improve performance and allow a more accurate comparability and consistency between competitive performances (Morton 2009; Nikolopoulos, Arkinstall and Hawley 2001). The implementation of methods which alter perceptions of exertion during exercise is one area of interest that may provide insight into how this may be achieved.

1.2 DECEPTION

Deception has recently emerged as a common approach to manipulate key variables during exercise. In addition to the advancement of our mechanistic understanding of exercise regulation, a further aim of deception investigations lies in the practical application of these strategies. Many studies endeavour to determine how pacing strategies and effort exertion can be optimised, i.e. by covertly accessing metabolic and psychological reserves, in order to improve overall athletic performance. The manipulation of central psychological mechanisms, including the presence of a competitor (Corbett et al. 2012; Stone et al. 2012) and hypnosis (Williamson, McColl and Matthews 2001), as well as psychological skills training (Barwood, Weston and Thelwell 2009) have been reported to improve performance by accessing this reserve. Studies that have examined the placebo effect, using inert substances believed to be ergogenic, also report that false positive beliefs elicit performance improvements (Beedie and Foad 2009). Altering perceptions of the exercise requires an element of deception in order to prevent the threat to internal validity from expectancy. However, whilst the manipulation of the provision of external feedback has been researched, evidence for the effects of the deception of this feedback, and resultant false beliefs, on performance has been equivocal. In the current body of literature (Table 1.1), vast differences in methodology, including the variables manipulated, timing of the deception, training status of the participants, and the exercise modality, has created a field of research where conclusions are difficult to form and the underlying mechanisms cannot be established.

Table 1.1 Description and key findings of prior deception studies.

Reference	Participant information	Exercise protocol	Type of deception	Variable(s) manipulated	Variable(s) measured	Key findings
Baden et al. (2005)	n=16 M + F	20 min running	Unknown duration	Exercise endpoint	Heart rate RPE Affect VO ₂ Stride frequency Attentional focus	↑ RPE and ↓ affect in DEC when unexpected increase was revealed ↓ VO ₂ in latter half of unknown duration trial NSD in heart rate or stride frequency
	Moderately-trained	(fixed 75% of peak speed)	Unexpected change in duration			
Eston et al. (2012)	n=20 M	20 min running and cycling	Unknown duration	Exercise endpoint	Heart rate RPE Affect VO ₂	↑ RPE (running) and ↓ affect (running and cycling) in DEC when unexpected increase was revealed NSD in VO ₂ (running and cycling), ↓ heart rate (running and cycling) and ↓ RPE (running) in unknown duration trial
	Untrained	(fixed 75% and 60% of VO _{2peak})	Unexpected change in duration			
Billaut et al. (2011)	n=14 F	6 s repeated cycling sprints	Unknown duration	Exercise endpoint	Mechanical work PO EMG RPE	↑ EMG, work accumulated and peak PO in initial sprint in DEC ↑ EMG and work accumulated in DEC in first 5 sprints ↓ work accumulated in unknown duration trial. NSD in RPE
	Trained		Unexpected change in duration			
Mauger, Jones and Williams (2009)	n=18 M Well-trained	4 km cycling TT	Unknown duration and blind feedback	Exercise endpoint Previous experience	Performance time PO Speed EMG BLa	↑ performance time in DEC Differences reduced over successive TT

Williams, Bailey and Mauger (2012)	n=22 M Untrained	4 km cycling TT	Unknown duration and blind feedback	Exercise endpoint Previous experience	Performance time PO Speed Heart rate RPE VO ₂	NSD in performance time, PO, speed, heart rate or VO ₂
Ansley et al. (2004)	n=8 M Untrained	30, 33 and 36 s Wingate Anaerobic Test	False expectation of endpoint	Exercise endpoint	PO Fatigue index	↓ PO in last 6 s of 36 s DEC NSD in PO between trials in first 30 s
Nikolopoulos, Arkinstall and Hawley (2001)	n=16 M Well-trained	34, 40 and 46 km cycling TT	False expectation of endpoint	Exercise endpoint	Performance time PO Heart rate RPE	NSD in performance time between DEC and control trials of the same distance NSD in PO, heart rate or RPE
Paterson and Marino (2004)	n=21 M + F Trained	24, 30 and 36 km cycling TT	False expectation of endpoint	Exercise endpoint Previous experience	Performance time PO Heart rate RPE	↓ Performance time from TT1 to TT3 in 36 km trial ↑ performance time from TT1 to TT3 in 24 km trial NSD in performance time from TT1 to TT3 in 24 km trial
Hampson, St Clair Gibson and Lambert (2004)	n=40 M + F Well-trained	1.68 km running (fixed 80, 83 and 86% of peak speed)	Intensity	Speed	Heart rate RPE -16 point scale - category-ratio scale	NSD in RPE or heart rate
Pires and Hammond (2012)	n=8 M Untrained	Cycling trial to exhaustion	Intensity	RPE	Time to exhaustion Heart rate RPE	NSD in time to exhaustion, heart rate or RPE

Taylor and Smith (2014)	n=8 M + F Well-trained	Sprint distance Triathlon (fixed 1.66 km of run)	Intensity	Speed of previous performance	Performance time Heart rate BLa VO ₂ , V _E , RER Muscular pain Breathlessness Affect Thermal discomfort RPE	NSD in performance times, physiological variables or perceptual measures Weak relationships between speed and perceptual measures
Faulkner, Arnold and Eston (2011)	n=13 M Untrained	6 km running TT	Inaccurate discontinuous verbal feedback Blind feedback	Distance	Performance time Heart rate RPE VO ₂ Running economy Velocity	↓ performance time, VO ₂ and heart rate in blind feedback trial than in accurate and premature feedback trials Fastest performance time in delayed feedback trial but not statistically different NSD in RPE
Beedie, Lane and Wilson (2012)	n=7 (gender unknown) Well-trained	10 mile cycling TT	Inaccurate discontinuous verbal feedback	Split times	Performance time PO Heart rate VO ₂ V _E BLa Blood glucose Emotions	NSD in performance time, PO, heart rate or V _E ↓ VO ₂ , ↑ BLa, ↑ positive emotions, ↓ effort to regulate emotions in false positive feedback trial than in the false negative feedback trial
Wilson et al. (2012)	n=7 (gender unknown) Well-trained	10 mile cycling TT	Inaccurate discontinuous verbal feedback Blind feedback	Split times	Performance time PO Heart rate VO ₂ V _E	NSD in performance time, PO or heart rate ↑ VO ₂ and VE in false negative and blind feedback trials

Mauger, Jones and Williams (2011)	n=5 M Well-trained	4 km cycling TT	Inaccurate discontinuous feedback	Split times	BLa Performance time Speed	↓ performance time and ↑ mean speed in accurate feedback trial
Micklewright et al. (2010)	n=29 M Well-trained	20 km cycling TT	Inaccurate continuous visual feedback	Speed and distance covered Previous experience	Performance time PO Speed Cadence RPE	NSD in performance time ↑ PO and speed in first 5km of TT3 in DEC
Stone et al. (2012)	n=9 M Trained	4 km cycling TT	Inaccurate continuous visual feedback	Previous performance	Performance time PO Cadence Heart rate VO ₂ RER Aerobic and anaerobic energy	↓ performance time and ↑ anaerobic energy contribution in DEC
Corbett et al. (2012)	n=14 M Untrained	2 km cycling TT	Inaccurate continuous visual feedback	Competitor knowledge	Performance time PO VO ₂ BLa Aerobic and anaerobic energy	↓ performance time in DEC
Morton (2009)	n=12 M + F Untrained	Cycling trial to exhaustion	Inaccurate continuous visual feedback	Time	Time to exhaustion	↑ time to exhaustion in slow running clock trial
Thomas and Renfree (2010)	n=8 M Well-trained	10 km cycling TT	Inaccurate continuous visual feedback	Time	Performance time Speed RPE Performance	NSD in performance time ↑ magnitude of end spurt in slow running clock trial

					expectations	
Parry, Chinnasamy and Micklewright (2012)	n=15 (gender unknown) Moderately-trained	20 km cycling TT	Inaccurate continuous visual feedback	Optic flow	Performance time PO Cadence Heart rate RPE	↑ PO and ↓ RPE in slow running video footage trial
Marquez et al. (2002)	n=59 F Untrained	20 min running (intensity of 12-16 RPE)	Qualitative feedback	Self-efficacy	Self-efficacy Anxiety Heart rate RPE	↓ self-efficacy and ↑ anxiety in low efficacy condition
Motl et al. (2006)	n=28 F Untrained	30 min cycling (60% of VO _{2peak})	Qualitative feedback	Self-efficacy	Self-efficacy Work-rate VO ₂ RPE Perceptions of pain	NSD in muscle pain or RPE
Hu et al. (2007)	n=28 F Untrained	30 min cycling (60% of VO _{2peak})	Qualitative feedback	Self-efficacy	Self-efficacy Enjoyment	↑ enjoyment in high efficacy condition
Stoate, Wulf and Lewthwaite (2012)	n=20 M + F Trained	20 min running (75% VO _{2max})	Qualitative feedback	Running style efficiency	Heart rate RPE VO ₂	↓ VO ₂ and ↑ positive affect in DEC NSD in heart rate

M = Male; **F** = Female; **VO₂** = oxygen uptake; **↑** = significantly greater ($P < 0.05$); **↓** = significantly lower ($P < 0.05$); **RPE** = Ratings of Perceived Exertion; **DEC** = Deception trial; **NSD** = No statistical differences ($P > 0.05$); **VO_{2peak}** = Peak value of oxygen uptake recorded during a graded exercise test; **PO** = Power output; **EMG** = Electromyography; **TT** = Time trial; **BLa** = Blood lactate; **V_E** = Minute ventilation; **VO_{2max}** = Maximal oxygen uptake recorded during a graded exercise test, indicated by a plateau.

1.2.1 Endpoint Manipulation

A number of deception studies have manipulated participants' knowledge of the exercise duration or endpoint by providing no knowledge of the exercise duration (Eston, Stansfield and Westoby 2012; Williams, Bailey and Mauger 2012; Billaut, Bishop and Schaerz 2011; Mauger, Jones and Williams 2009; Baden, McLean and Tucker 2005) or false endpoint information prior to the exercise bout (Ansley et al. 2004; Paterson and Marino 2004; Nikolopolous, Arkinstall and Hawley 2001; Palmer, Backx and Hawley 1998). Knowledge of the endpoint of exercise is said to be crucial in the setting of an optimal initial pace therefore with no or incorrect information, the importance of this knowledge can be examined. Firstly, if the duration is unknown, the exercise becomes an open-loop task and the role of previous experience is one of ensuring completion of the exercise rather than optimal performance. It has been commonly shown that without this knowledge, a sub-optimum performance will occur in comparison to equivalent duration closed-loop tasks (Eston et al. 2012; Billaut et al. 2011; Baden et al. 2005). Work-rate is more conservatively selected to produce an effort that is considered tolerable for protracted periods of time and will not reach maximum levels prior to the exercise endpoint. A conservation of physiological resources ensures a sufficient reserve capacity is maintained in order to avoid premature fatigue and failure to complete the exercise in the anticipation of a longer duration (Tucker and Noakes 2009).

Secondly, other studies have explored how false expectations of the exercise endpoint influence pacing strategy via the provision of incorrect knowledge of the exercise duration or distance (Eston et al. 2012; Billaut et al. 2011; Baden et al. 2005; Ansley et al. 2004; Paterson and Marino 2004; Nikolopolous, Arkinstall and Hawley 2001). Whilst one study demonstrated that false expectations resulted in a reduction in power output when the duration of a Wingate Anaerobic Test exceeded the duration that was expected (Ansley et al. 2004), no other evidence for an alteration of pacing strategy, perceived exertion or overall performance has been found (Paterson and Marino 2004; Nikolopolous, Arkinstall and Hawley 2001). Where perceived exertion was measured, no differences between deception and control conditions were found, and no further investigations of perceptual

responses were explored. On the other hand, acute changes in RPE and affect have been evidenced in studies where the deception of endpoint knowledge was revealed during the exercise bout (Eston et al. 2012; Baden et al. 2005). Affect evaluates core emotions of pleasure/displeasure (Hardy and Rejeski 1989) and responses were measured alongside perceived exertion. Both RPE and affect were worsened when participants were informed that the expected endpoint was incorrect and they were required to continue exercising for a longer duration. Eston et al. (2012) and Baden et al.'s (2005) studies are some of the few investigations in this field to explore the affective responses to deception, with their results supporting the criticism that RPE should not be the sole perceptual measure during exercise (Renfree et al. 2014). It is proposed that affect provides further understanding of how one feels during exercise, and not just what one feels (Hardy and Rejeski 1989) and whilst the RPE is suggested to have an affective component, these studies have evidenced that affect can be dissociated from RPE (Eston et al. 2012; Baden et al. 2004).

In summary, the provision of false endpoint knowledge has commonly been shown to have no effect on pacing strategy or performance during exercise, but in studies where perceptual measures have been more thoroughly explored, it has been suggested that deception does influence the exertional and affective responses experienced when it is revealed to the athletes. It should be noted that open-loop exercise or exercise with a false endpoint, whether self-paced or fixed-intensity, is not something that most athletes will ever be required to perform either in training or competition. These methodological approaches are usually used as an experimental model to investigate absolute limits of performance (often as time to exhaustion) or associated physiological and psychological responses, or as a comparator to understand the relevance of endpoint awareness on athletic behaviour. Externally valid performance manipulations may instead provide a more practical application for how deceptive interventions can be used to explore the regulation of athletic performance and the potential means of accessing a metabolic reserve to enhance this performance.

1.2.2 Manipulation of Performance Feedback

Athletes will use performance feedback such as time, speed and power output as external cues during training and competitions to regulate pace. Hence the manipulation of this feedback and the creation of false performance beliefs provides an exploration of the importance of these variables. The manipulation of time elapsed or distance covered feedback produces a mismatch in how the athlete perceives they are performing based on experience-primed knowledge, versus how they are actually performing. They will therefore perceive that they are performing better or worse than what they believe is their optimal performance. In cycling or running TTs of a known distance, for example, participants were deceived that they were closer to, or further away from, the endpoint of the exercise via the manipulation of split feedback regarding the distance covered or time elapsed (Beedie, Lane and Wilson 2012; Wilson, Lane and Beedie 2012; Faulkner, Arnold and Eston 2011; Albertus et al. 2005). None of these studies demonstrated significant differences in overall performance, pacing strategy or RPE in comparison to trials with accurate split feedback. This suggests that distance and time feedback provided in this intermittent manner during exercise does not modify performance. One study did, however, examine the role of emotions in the identification of underlying psychological mechanisms that could explain how belief effects, manipulated via deception, could affect performance (Beedie, Lane and Wilson 2012). These authors demonstrated that the provision of false positive time feedback reduced the amount of effort required to regulate emotions and elicited a more positive emotional experience. This could suggest that whilst inaccurate feedback might not influence pace or performance, the emotional experiences during the exercise are affected.

Alternatively, other studies have manipulated the provision of continuous visual feedback throughout an exercise bout via a running clock, the display of performance data, or the profile of a comparable performance projected on-screen (Corbett et al. 2012; Parry, Chinnasamy and Micklewright 2012; Stone et al. 2012; Williams, Bailey and Mauger 2012; Micklewright et al. 2010; Thomas and Renfree 2010; Mauger, Jones and Williams 2009; Morton 2009). A slower running clock has

been shown to lengthen time to exhaustion and increase the end spurt magnitude in cycling TTs (Thomas and Renfree 2010; Morton 2009). Similarly, where optic flow was manipulated, a condition where video footage was running slow facilitated an increase in power output with accompanying lower RPE (Parry, Chinnasamy and Micklewright 2012). These manipulations support the facilitative effect of false negative perceptions of performance, however, the limited number of experimental variables measured creates speculation as to what mechanisms may have been responsible for these performance improvements.

Other methodological designs that have elicited improvements in performance via deceptive interventions have used feedback relating to an athlete's own previous performance or feedback pertaining to the performance of a competitor (Taylor and Smith 2014; Corbett et al. 2012; Stone et al. 2012; Williams, Bailey and Mauger 2012; Micklewright et al. 2010; Mauger, Jones and Williams 2009). Knowledge of the exercise endpoint has been considered to be one of the key variables which determines exercise regulation (St Clair Gibson et al. 2006; St Clair Gibson, Schabort and Noakes 2001; Ulmer 1996), however, the role of prior experience has not previously received the same level of investigation in this area. The perceived significance of this performance knowledge, and the experimental support which suggests that it may be more important than endpoint knowledge in the optimisation of pacing strategy (Mauger, Jones and Williams 2009), indicates that this clearly warrants future investigation. Studies that have adopted methodological approaches involving the manipulation of previous experience perceptions, have evidenced interesting results and demonstrated that performance can be improved (Stone et al. 2012; Micklewright et al. 2010; Mauger, Jones and Williams 2009).

Micklewright et al. (2010) investigated the effect of previous experience and performance feedback on successive 20 km cycling TTs. Three groups (blind, accurate and false feedback) each completed three trials in which all groups received accurate feedback in the third TT. In TT1 and 2, participants in the false feedback group perceived their performance was 5% better than actual performance via the manipulation of speed and distance covered feedback. The blind feedback group, who received no feedback in TT1 and 2, showed

improvements in performance from TT2 to TT3, but no differences in completion time or average speed were found in the accurate or false feedback groups. An alteration of pacing strategy was demonstrated in the false feedback group, with a reduced cadence and greater power output in the first 5 km of TT3 compared to TT2. The perception that their performance was greater than it actually was in the deception trials may have enabled participants to use previous experience in the enhancement of belief effects. This is predicted to influence perceived exertion and pacing strategy, consequently resulting in residual performance improvements and thus supporting results found by Paterson and Marino (2004). However, unlike in this earlier study, an initial trial with accurate feedback was not completed so it is unknown whether the greater power output seen in TT3 was also evident in comparison to a previous baseline performance and therefore demonstrating a residual effect. Self-efficacy beliefs are known to improve with mastery experiences, therefore prior experience of a given task is likely to be crucial to sequential perceptions of an individual's capabilities (Bandura 1997). Unfortunately, it is uncertain how proposed belief effects acted to enhance performance as no perceptual measurements, such as self-efficacy, were taken (Micklewright et al. 2010). Despite a faster start in TT3 by the false feedback group, performance was not improved as this pace could not be sustained and power and speed fell after 13 km (Micklewright et al. 2010). A 5% deception may have been too large and conscious or subconscious control may have governed a reduction in work-rate to prevent excessive discomfort or homeostatic failure, consequently negatively affecting performance. This also lends support to the expected consequence of an incorrect comparison between the anticipatory RPE template and conscious RPE of premature fatigue (Tucker 2009). However, RPE was not measured in TT1 or TT2 and statistical differences between RPE in TT3 between feedback conditions were not reported.

Stone et al. (2012) recognised that the 5% speed deception used in Micklewright et al.'s (2010) study was likely too large a discrepancy and was detected, so instead employed a 2% power output deception based upon typical error values and smallest worthwhile change in 4 km cycling TTs (Stone, Thomas and Wilkinson

2011). As speed and power output are not linearly related, and a respective ratio of 1:2.9 is proposed (Flyger 2008), it can be calculated that the 5% increase in speed in Micklewright et al.'s (2010) study equates to a 14.5% increase in power. Participants performed a baseline trial that was projected onto a screen as an avatar in a subsequent deception trial. Participants believed the visual performance profile of the avatar represented their average baseline power output; however it was manipulated to display a power output corresponding to 2% greater than the baseline. Results showed that deception trials were significantly faster and had a higher mean power output than both an accurate feedback condition and the baseline performance, suggesting that the deception of intensity based on a previous trial was beneficial to TT performance. Corbett et al. (2012) also used the presence of a simulated competitor, deceiving participants into believing that it was an athlete of similar ability when it was in fact their own baseline performance, and further supported Stone et al.'s (2012) findings. A faster performance time and alteration in pacing strategy in a 2 km cycling TT were reported in the trial with head-to-head competition, in comparison to familiarisation and ride-alone trials.

The presence of competitors during a race or event is one factor which complicates and adds pressure to decision-making processes (Renfree et al. 2014). Depending on the goal of the exercise, to complete in the fastest time possible (e.g. TT) or to finish ahead of others (e.g. Tour stage, running races), an athlete's decisions can be influenced in anticipation of and in response to the behaviour of competitors (Renfree et al. 2014). In competitive environments, performance becomes outcome-orientated and decision-making and other psychological mechanisms hold significant importance to the result. Consequently, the findings from single muscle experiments, electrical stimulation, or modes of exercise under standardised conditions are limited in their applicability to competitive performance from physiological, cognitive and biomechanical perspectives. Decision-making is heavily influenced by situations in which there are high levels of uncertainty (Renfree et al. 2014), therefore a competitive environment creating more unpredictability may demand more complex and frequent decisions to be made regarding work-rate. The more complex an environment, for example competitive situations with numerous

external cues, the poorer an athlete's decision-making may be. Heuristic decision-making processes are likely to be used as the outcome of actions is difficult to accurately calculate, for example, the behaviour of competitors later in the race if a cyclist chooses to break away from the peloton (Renfree et al. 2014). The presence of competitors could therefore create more environmental noise and uncertainty, provoking a higher than optimal work-rates that cannot be sustained, resulting in an underperformance. This has been evidenced with the provision of false feedback (Micklewright et al. 2010), showing that when decisions are made on perceived and not actual information, performance can be negatively affected. Alternatively, false competitor feedback has also evoked improvements in performance resulting from better decision-making or the prevention of poor decision-making, e.g. reducing or not increasing work-rate which prevents true maximal physiological capabilities from being achieved (Williams, Jones and Sparks 2014; Corbett et al. 2012; Stone et al. 2012). This decision-making perspective can therefore be used to explain how deception affects exercise regulation and performance during self-paced exercise. A number of these studies, however, used a computer projected image of an avatar or video footage of a road as oppose to a digital display of time or performance variables (Williams et al. 2014; Corbett et al. 2012; Parry, Chinnasamy and Micklewright 2012; Stone et al. 2012). The stimuli of visual race environments or the presence of a competitor may have had additional effects via their influence on potential motivation or social facilitative processes and therefore had a mediating role between deception and the effect on performance (Corbett et al. 2012; Marcora 2008; Weinberg, Gould and Yukelson 1981; Weinberg, Yukelson and Jackson 1980; Weinberg, Gould and Jackson 1979). With none of the studies measuring motivational states or any other psychological variables, this suggestion warrants further authentication.

Different mechanisms were proposed in each of these studies to explain why performance improved. Stone et al. (2012) and Corbett et al. (2012) both showed that in the final 10% and 50% of the deception trials, respectively, there was a greater contribution from anaerobic energy sources that resulted in the increases in power output and faster completion time. Alternatively, Parry and colleagues

(2012) stated that a shallower rate of RPE increase, and an increase in work-rate to complete the exercise sooner, resulted in an increase in power output. Morton (2009) and Faulkner, Arnold and Eston (2011) both suggested that work-rate is increased to rectify a poorer performance, suggesting that motivation is a contributing factor. However, the latter conclusion was made in relation to 'competitive' individuals despite neither study using well-trained athletes, or providing supporting evidence of changes in RPE (Faulkner, Arnold and Eston 2011; Morton 2009). With differences in the nature of the feedback deception and exercise protocols between these studies, it may not be realistic to expect that a single, common mechanism is responsible for changes in performance and it is more likely that, rather than acting mutually exclusively, these proposed physiological and psychological mechanisms occur in a mediating and causal manner. However, with an overall lack of supporting evidence, for example none of the aforementioned studies measured any perceptual constructs other than RPE, the purported mechanisms require further investigation. Additionally, these conclusions may offer explanations for how performance is changed when a deceptive intervention is implemented, but may not be effective explanations of the mechanisms responsible for why deception achieves this.

1.2.3 Qualitative Feedback Manipulations

Most studies in the field of deception have manipulated participants' knowledge of the endpoint, distance or duration of the exercise and performance variables such as intensity and speed. However, studies manipulating qualitative performance feedback during running or cycling exercise have been less forthcoming (Hu, Motl and McAuley 2007; Motl, Konopack and Hu 2006; Marquez, Jerome and McAuley 2002). Social cognitive theory has informed the construct of self-efficacy; defined as an individual's judgement of their confidence to carry out a specific behaviour (Bandura 1986). In an exercise setting, task-specific self-efficacy expectations have been previously measured to predict and explain behaviour, effort investment and persistence (Tenenbaum, Lidor and Lavyan 2005). Studies that have manipulated self-efficacy using false performance feedback have shown that higher task-specific self-efficacy is related to less anxiety (Marquez et al. 2002) and more enjoyment of

the exercise (Hu et al. 2007), than low self-efficacy groups. However, one study (Motl et al. 2006) found no effect on RPE or muscle pain intensity when self-efficacy was manipulated during moderate-intensity exercise, which supports the suggestion that the relationship between self-efficacy and perceived effort may be intensity-dependant (Hall, Ekkekakis and Petruzzello 2005). A study by Stoate, Wulf and Lewthwaite (2012) investigated whether feedback pertaining to the efficiency of performance during a running bout would influence movement efficiency. Lower oxygen uptake, more marked changes in perceptions of performance and greater positive affect were shown in the group that received positive fabricated feedback compared to a control group with no feedback. However, this is in contrast to research which has shown that falsely enhancing perceptions of performance via feedback of physiological variables does not improve performance (Parry, Chinnasamy and Micklewright 2012; Micklewright et al. 2010; Thomas and Renfree 2010; Morton 2009). This suggests that the mechanisms by which feedback affects exercise performance may differ depending upon the type of deceptive feedback that is provided; informational or videographical. The manner in which this feedback is delivered may influence perceptual experiences, given that verbal persuasion is considered a key determinant of self-efficacy (Bandura 1986). Feedback provided in person in an encouraging manner (Stoate, Wulf and Lewthwaite 2012) could be interpreted and valued differently to feedback provided simply in informational terms, which further requires the individual's own appraisal (Beedie, Lane and Wilson 2012; Parry, Chinnasamy and Micklewright 2012; Wilson et al. 2012; Micklewright et al. 2010; Thomas and Renfree 2010; Morton 2009).

1.3 SUMMARY AND LIMITATIONS

There are a number of ways in which deception interventions have been designed, each intending to gain particular insights into pacing behaviour and performance. Deception methodologies can be conceptualised according to a number of dimensions such as deception timing (prior to or during exercise); presentation frequency (discontinuous or continuous); and type of deception (endpoint, time, speed, competitor presence). The implementation of complex designs and varied methodologies, however, make it difficult to draw clear conclusions about how

pacing strategy and performance are affected by deception manipulations. Studies that deceive participants prior to exercise may provide insights about the role of information on pre-event pacing decisions. Deceptions that are made during exercise, either in continuous or discontinuous form, have revealed more about the influence of information on on-going adjustments to pace. A number of studies have deceived participants about the exercise endpoint and few have used performance manipulations, focusing on competitor behaviour or optic flow. Both endpoint manipulations and discontinuous external feedback deceptions have negligible effects on pacing strategy or performance in endurance exercise (Faulkner, Arnold, and Eston 2011; Albertus et al. 2005; Nikolopoulos, Arkinstall and Hawley 2001). The manipulation of continuous visual feedback, on the other hand, has elicited improvements in cycling TT performance despite vast differences in the methodological approaches adopted (Corbett et al. 2012; Parry, Chinnasamy and Micklewright 2012; Stone et al. 2012; Thomas and Renfree 2010; Mauger, Jones and Williams 2009; Morton 2009). The confounding effect of social facilitation of the feedback requires further exploration, but creating a perception of performance that is worse than is actually taking place at the time appears to be a successful manipulation to improve performance. This is interesting considering that mastery experiences achieved through successful performance are proposed to have the strongest impact upon the enhancement of self-efficacy and, in turn, exercise tolerance (Hutchinson, Sherman and Martinovic 2008; Bandura 1986). Therefore, the cognitive mechanisms underlying these perceptions of endurance performance and accompanying effects on overall performance require clarification.

1.3.1 Exercise Mode Limitations

Studies using exercise of fixed-duration or fixed-intensity, or exercise of an unknown duration have aimed to assess central mechanisms but lack external validity to competitive performance. In exercise of a fixed work-rate, individuals are not required to self-regulate their pace and therefore the factors influencing decisions to alter pace during exercise cannot be investigated. Furthermore, when compared to exercise in the field, laboratory-based environments where external

and internal conditions are largely controlled and standardised, also constitute fewer threats to the projected pacing strategy and less periods of uncertainty that lead to these alterations in neural drive. Whilst these methodological designs allow researchers to manipulate and examine specific pacing mechanisms during exercise, they may oversimplify the complex and dynamic processes involved in pacing which are evident in sporting performances (Renfree et al. 2014). Furthermore, where a loss of perceived control and autonomy is incurred, it has been suggested that affective responses, self-efficacy expectations and perceived exertion would be impaired (Ekkekakis, Parfitt and Petruzello 2011; Lind, Ekkekakis and Vazou 2008). Less personal control (e.g. externally governed intensity) and a controlling influence from others (e.g. presence of competitors, feedback provision) are proposed to be influential cognitive factors in exertional, affective and self-efficacy perceptions as well as effect the strength of the relationships between these constructs (Welch, Hulley and Beauchamp 2010). Often, untrained participants have also been used who are unaccustomed to the exercise and have no previous experience or pacing schemas, which may limit our understanding of how trained athletes respond to deception interventions.

1.3.2 Mechanistic Considerations

In addition to a more thorough deliberation of research design, the variables measured should also be considered in future investigations. Psychological variables are often thought to play a key role in mediating the performance outcome in deception studies, however, this has often been poorly conceptualised (e.g., discussing motivation in general terms without appreciating its complex nature) or operationalized in the adopted methods (e.g., limited measurement of key psychological states). The increased acknowledgement of the limitations of RPE and the emergence of affect as a prospective mechanism of exercise regulation, has led to a number of recent pacing studies measuring affect and other perceptual cues throughout exercise instead of just pre- and post-exercise (Taylor and Smith 2014; Renfree, West and Corbett 2012). As affective valence varies over time and fluctuates depending on the interpretation of the given situation (Hardy and Rejeski 1989), intermittent during-task measures better examine how changes in affect

may relate to pacing decisions made throughout exercise. Positive affective state is said to elicit an increase in exercise intensity whereas negative affect would cause a reduction in motivation and consequential decrease in intensity (Baron et al. 2011). Affect will be influenced by goal perceptions, as risks are weighed against benefits and resultant pacing decisions made (Renfree et al. 2014). For example, if the risk of physiological damage outweighs the reward of achieving the task goal (winning, successful performance), feelings of negative affective valence may cause work-rate to be reduced. On the other hand, trained athletes with strong efficacious expectancies have high degrees of tolerance in the face of aversion and are familiar with high intensity, high effort exertional tasks (Tenenbaum et al. 2005). Therefore, despite possible feelings of negative affect or reduced self-efficacy as intensity exceeds ventilatory threshold and high levels of peripheral fatigue are experienced, strong motivation and goal persistence may prevent a reduction in work-rate as suggested. The findings of affective responses from exercise settings, often in adherence applications with untrained populations, are therefore unlikely to be transferable to elite performance settings and require further exploration.

Task-specific self-efficacy expectations have been linked to processes such as goal achievement, exercise tolerance (Hutchinson et al. 2008), effort expenditure (Bandura 1997) and consequently performance. Thus self-efficacy may be another potentially important perceptual construct involved in the regulation of exercise. Efficacy perceptions are also a key component of self-regulatory processes and have been examined in the study of self-modelling as a tool to enhance mastery experiences and influence performance (Ste-Marie, Vertes and Rymal 2011; Rymal, Martini and Ste-Marie 2010; Clark and Ste-Marie 2007). These studies have demonstrated that self-as-a-model interventions, providing video footage of an individual's prior performance, can improve physical performance (Ste-Marie et al. 2011; Clark and Ste-Marie 2007) and increase efficacy perceptions (Rymal, Martini and Ste-Marie 2010). Additionally, the use of feed-forward self-modelling can be compared to the manipulation of visual feedback of a prior experience as previously discussed (Stone et al. 2012), as it utilises the video of the self performing above one's capabilities (Ste-Marie et al. 2011). This research has yielded inconsistent

results regarding the influence of self-modelling on self-efficacy, but has implied that affective responses may be another psychological process worth exploring in the context of self-modelling benefits (Ste-Marie et al. 2011, Rymal, Martini and Ste-Marie 2010). Sources such as affective cues, physiological status and mastery experiences are all identified to influence individuals' cognitive appraisals (Bandura 1997; 1986), explaining the relationship found between affect and self-efficacy but the strength of this relationship has been suggested to differ in exercise of varying intensities (Tate, Petruzzello and Lox 1995; McAuley and Courneya 1992).

Similar to affect, the repeated measurement of self-efficacy expectations throughout an exercise bout and not simply pre and post assessments has been limited. Welch, Hulley and Beauchamp (2010) were the first in the field to measure self-efficacy during exercise; with fixed-pace known and unknown durations. Both self-efficacy and affective responses were found to differ between the unknown and known conditions and demonstrated similar response patterns, also supporting that during-exercise relationships were stronger than pre and post relationships. Lower perceptions of self-efficacy at the end of the unknown condition support Bandura's (1997) proposal that an individual's personal efficacy is impaired when uncertainty exists regarding the requirements and demands of the task being performed. An accompanying reduction in affective valence and increase in RPE toward the end of the unknown condition may also demonstrate the negative and reciprocal connotations of these cognitive constructs. Further investigation of the relationship between perceived exertion, affective valence and self-efficacy during exercise is consequently warranted if we are to further our understanding of these mechanisms and determine what types of deception could be best used to improve performance (Welch, Hulley and Beauchamp 2010).

1.4 AIMS OF THE RESEARCH

The aims of this thesis are to investigate the mechanisms of pacing strategy in maximal self-paced exercise, with the analysis of multiple physiological and perceptual variables. The measurement of variables such as affect and self-efficacy alongside physiological data such as heart rate and respiratory gases, enables a

more holistic evaluation of the interaction of these cues and dominance of these mechanisms on pacing decisions. Furthermore, deception strategies are assessed in their ability to influence pacing strategy and overall performance via their influence on beliefs and expectations. The deception strategy employed pertains to the manipulation of continuous visual feedback relating to an athlete's previous performance; represented as a simulated virtual avatar. The residual effects of this deception are explored to investigate the global, enduring effects of this type of intervention and thus the potential practical implications.

The specific aims addressed in each individual experimental study are outlined below.

Study 1: To examine pacing strategy and the associated changes in affect, perceived exertion, sense of effort, self-efficacy and physiological responses during both 16.1 km and 40 km self-paced cycling TTs. A secondary aim is to determine whether physical perceptions of exertion can be differentiated from the task effort and awareness during self-paced TTs.

Study 2: To explore the acute and residual effects of the deception of previous performance knowledge on affect, RPE, self-efficacy and performance in 16.1 km self-paced cycling TTs.

Study 3: To investigate the influence of false performance beliefs on affect, RPE, self-efficacy and performance in 16.1 km self-paced cycling TTs.

Chapter 2

General Methods

2.1 INTRODUCTION

This chapter outlines the general methods that were adopted in each of the three experimental studies conducted as part of this thesis (Chapters 3-5). Description of and rationale for the equipment, measurement techniques and general procedures that are common across each study are outlined in this chapter. The specific methodological aspects unique to each individual study are discussed in the relevant chapters.

2.2 PARTICIPANTS

Male cyclists and triathletes (>18 years old) were recruited from local cycling clubs, TTs and competitive cycling events. Inclusion criteria required that all participants were training for a minimum of 5 hrs or 100 km·week⁻¹ at the time of testing and had at least 12 months of competitive cycling experience. Additional criteria necessitated that participants also had experience of competing in 16.1 km TTs. This was to obtain more valid and consistent pacing profiles, ultimately better enabling the sensitivity of the measurements and allowing for the detection of potentially small worthwhile changes in variables.

Each experimental study required participants to complete a maximal incremental test to determine their peak oxygen uptake (VO_{2peak}), maximal power output and maximal heart rate (section 2.7). In accordance with performance level criteria as proposed by De Pauw, Roelands and Cheung (2013) (Table 2.1), mean VO_{2peak} and maximal power output values were used to classify participants in each study (i.e. 1 untrained, 2 healthy, 3 trained, 4 well trained, 5 professional). These classifications were made to permit more effective quantification and comparison of the participants' performance level between the studies in thesis and with contemporary research.

Table 2.1 Criteria to classify cyclist's performance level (PL)

	PL 1 (Untrained)	PL 2 (Recreationally trained)	PL 3 (Trained)	PL 4 (Well- trained)	PL 5 (Professional)
Absolute PPO (W)	< 280	280-319	320-379	380-440	> 350
Relative PPO (W/kg)	< 4.0	3.6-4.5	4.6-5.5	4.9-6.4	> 5.5
Relative VO _{2max} (mL·kg·min ⁻¹)	< 45	45-54.9	55-64.9	65-71	> 71
Absolute VO _{2max} (L·min ⁻¹)	< 3.7	3.4-4.2	4.2-4.9	4.5-5.3	> 5.0
Cycling training (hrs·week ⁻¹)	< 2-3	4	≥ 5	≥ 10	≥ 10
Cycling experience (years)	-	-	-	≥ 3	≥ 5

PPO = peak power output; **VO_{2max}** = maximal oxygen uptake

Adapted from De Pauw et al. (2013)

2.3 INFORMED CONSENT AND ETHICAL APPROVAL

Prior to participation in any study, the procedures, benefits and risks were fully explained to each participant and written informed consent was attained (Appendix 1 and 2). A Medical History Questionnaire was completed and participants were excluded from the study if any contraindications to maximal exercise were identified, such as chronic disease or injury. Those taking medication or supplements that may affect their responses to exercise were also excluded. A screening process was undertaken prior to each testing session and all studies were approved by the Department of Sport and Physical Activity Research Ethics Committee (SPA-REC-2012-0008; SPA-REC-2013-0126; SPA-REC-2014-295). If participants felt that injuries, muscle soreness or illnesses would prevent them from performing maximal exercise, they were encouraged to contact the principal researcher to reschedule testing.

Studies 2 and 3 adopted deceptive methodological research designs which were essential to achieve the study's aims and objectives and to prevent a threat to internal validity from expectancy effects. The British Psychological Society (BPS 2010) guidelines for research involving deception were adopted throughout the research period to inform ethical practices and to minimise the risk of psychological harm or distress that may be caused when there is an element of deception. These guidelines state that deception or covert data collection can be considered ethical

in experimental studies where it is necessary to the research results, the research has strong scientific merit and appropriate risk management strategies are in place (BPS 2010). Conformation with the ethical standards set by the Declaration of Helsinki (Department of Health 2008) was also met. Additionally, participants were not provided with full, comprehensive information as part of the informed consent process in order for this deception element to remain undetected. In line with recommendations, once testing was completed the participants were fully debriefed as to how they were deceived and why the deception was necessary.

2.4 EXPERIMENTAL CONDITIONS

All testing sessions were conducted in the laboratories in the Department of Sport and Physical Activity, Edge Hill University which were maintained at relatively constant environmental conditions of approximately 21°C and 40-60% humidity.

2.5 CONTROL MEASURES

Prior to each laboratory visit, participants were instructed to adhere to a number of control measures in order to standardise pre-exercise physiological and psychological states. Testing was conducted following the refrainment from strenuous exercise and alcohol consumption in the 24 hrs prior to each session and a 2 hr fast. Participants were instructed to maintain their normal diet and training routines throughout the testing period and provided nutritional and training diaries on their first visit. Diaries were replicated in the 24 hrs prior to each subsequent visit and suitable conformity was checked by the principle researcher. Fluid prescription in the preceding 2 hrs was a minimum of 500 ml and an index of hydration status was evaluated using a portable refractometry device (Osmocheck, Vitech, West Sussex, UK) which has been shown to be a valid instrument (Sparks and Close 2012). Testing only commenced once a sufficient hydration index was recorded, therefore in the event of dehydration ($> 650 \text{ mmol}\cdot\text{L}^{-1}$), participants were required to consume more fluids and repeat the evaluation. Each TT was conducted 2-7 days apart at the same time of day ($\pm 2 \text{ hrs}$) to account for circadian variation (Drust, Waterhouse and Atkinson 2005).

2.6 ANTHROPOMETRY

Anthropometric measurements, namely height and body mass, were recorded for each participant on their first visit to the laboratory. Body mass was additionally measured upon each subsequent visit and interpolated into the metabolic gas analysis and ergometry software to calculate relative variables. A wall-mounted precision stadiometer (Holtain, Harpenden HSK-BI, UK) was used to measure height to the nearest mm. Participants were instructed to stand with their feet together and their upper backs, buttocks and heels against the stadiometer. Their head was correctly aligned in the Frankfurt plane prior to the sliding scale being lowered to make contact with the top of the head and they were instructed to take a deep inhalation of breath before the value was recorded. Body mass was measured using a Precision Weighing Balance (Seca, MA, USA) and recorded to the nearest 0.1 kg, with participants wearing their exercise clothing but no footwear and following urination.

2.7 MAXIMAL INCREMENTAL TEST

A continuous incremental ramp test to maximal exertion on a cycle ergometer was also completed during the participants' first visit (Excalibur Sport, Lode, Groningen, The Netherlands) to determine VO_{2peak} . Following a 5 min warm-up at 100W, initial workloads and increments were determined for each participant using established British Cycling guidelines (Wooles, Keen and Palfreeman 2003). Protocol details are further discussed in the subsequent experimental chapters. The test was terminated according to the criteria of achieving a VO_{2peak} volitional exhaustion (Midgley, McNaughton and Polman 2007). Breath-by-breath pulmonary ventilation and gas exchange data were recorded throughout the test (Oxycon Pro, Jaeger, GmbH Hoechburg, Germany) (section 2.10.2.2 for further detail). Pulmonary oxygen uptake data were averaged in 20 s time bins and normalised to pre-exercise body mass data. The highest VO_2 measurement recorded over a 20 s period was used to classify VO_{2peak} (Dwyer 2004). Heart rate (section 2.10.2.1) was recorded continuously and downloaded at a 5 s sampling rate which has previously been established as a valid and reliable approach (Achten and Jeukendrup 2003). Verbal

encouragement was provided throughout each test (Andreacci, LeMura and Cohen 2002).

2.8 FAMILIARISATION TRIALS

Prior to any experimental testing, all participants completed familiarisation trials in the distance of the TTs they were to perform. In study 1, both 16.1 km and 40 km familiarisation TTs were completed and in studies 2 and 3, two 16.1 km TTs were initially completed. These sessions served to familiarise the participants with the procedures, laboratory environment and measurements that would be adopted in the experimental TTs in order to mitigate the influence of extraneous variables in subsequent performances. In self-paced exercise, small modifications to pacing strategies have been demonstrated following a bout of exercise which could be attributed to the uncertainty imposed by an initial testing session (Corbett, Vance and Lomax 2009). Even highly trained athletes with experience in the given exercise have demonstrated between-trial changes in mean power ranging from 1.2-2.3%, (Hopkins and Hewson, 2001; Schabert, Hawley and Hopkins 1999). Participants were not informed that these trials were for familiarisation purposes as to prevent sub-maximal efforts being produced. This was particularly important in studies 2 and 3 where one of these trials was used in the experimental analysis (Chapters 4 and 5).

2.9 EXPERIMENTAL PROCEDURES AND APPARATUS

2.9.1 Cycling Time Trials

In cycling research, laboratory-based cycling TTs are a commonly used protocol and most often completed on either stationary cycle ergometers or turbo trainers with participants riding on their own bicycles (Stone et al. 2012; Thomas, Stone and Thompson 2012; Micklewright et al. 2010; Noreen, Yamamoto and Clair 2010; Hettinga et al. 2006; Albertus et al. 2005; Nikolopoulos, Arkinstall and Hawley 2001). A TT is performed with the aim to complete a given distance in the fastest time possible. In the investigation of pacing strategies, self-paced TTs allow researchers to address external validity limitations associated with fixed-intensity

or fixed-duration cycling exercise. However, many previous pacing investigations have failed to consider these specific limitations of laboratory-based testing when examining complex, decision-making processes that are highly sensitive to external influences. Consequently, there exists a potential effect of these violations of validity on the generalisability of their findings to real-world performances. A key consideration of the study designs within this thesis aimed to alleviate such issues and enhance the generalisability of the results. Accordingly, the laboratory set-up for each of the studies within this project intended to replicate true competition as much as was possible. An immersive environment was created with the rider positioned in front of the virtual road, on their own bikes and with surrounding screens, in order to allow performance to be accurately modelled (Abbiss and Laursen 2008). Gearing selection, force exertion and cadence were all controlled entirely by the participant in order to allow pace to be profiled in each TT as it would be in an outdoor TT. However, the limitations associated with the monotonic nature of the gradient, wind and ambient environment is acknowledged as an inherent limitation with this approach. 16.1 km and 40 km TTs were chosen as they are the most commonly ridden distances in road time trialling, thereby further enhancing the external validity of the studies. This was deemed to be a suitable compromise between providing a close approximation of field TT conditions (satisfying external validity) while also providing suitable control over the environment (maintaining internal validity) to permit the study of the interventions in line with the research objectives (Drust, Atkinson and Reilly 2007; Atkinson and Nevill 2001). Previous research has demonstrated acceptable reliability in both 16.1 km and 40 km cycling TT performances provided a familiarisation trial is completed (Jeukendrup, Hopkins and Aragón-Vargas 2008; Laursen, Shing and Jenkins 2003).

2.9.2 CompuTrainer Ergometer

The cycle ergometer used in this series of studies was a CompuTrainer Pro (RacerMate, Seattle, USA). This electromagnetically-braked cycle ergometer allowed participants to perform each trial on their own bicycles. The same road or TT bicycle was ridden in each trial and participants were instructed not to make alterations to the setup of their bicycle for the duration of the testing period. The

ergometer was calibrated at each use in accordance with the manufacturer's guidelines and tyre pressures were standardised to 100 psi prior to each trial. CompuTrainer ergometers have been shown to be a reliable measure of test-retest power output across a range of intensities (coefficient of variation (CV): 1.2-1.9 %) (Stone et al. 2011; Noreen, Yamamoto and Clair 2010; Davison, Corbett and Ansley 2009; Zavortsky, Murias and Gow 2007) and are widely used in pacing research (Mauger, Jones and Williams 2010; Micklewright et al. 2010) as they allow the cyclists to freely alter their cadence and gear selection throughout the exercise. Using the CompuTrainer in our laboratory, a 0.6% CV was found for between-trial variation in performance times ($n = 31$). This is comparable to a smallest worthwhile change in road TT performance time of 0.6% as previously reported (Paton and Hopkins 2006).

Flat and windless virtual TT courses were designed using the ergometry software (RacerMate Software, Seattle, USA) and projected onto a 230 cm screen positioned 130 cm in front of the rider. The participants' performance profile was represented onscreen by a synchronised graphical avatar during each TT. Distance covered feedback was the only data made available to the participants; all other feedback, including power output, speed and time, were obscured from view and all time cues were removed from the laboratory. Time, power output, speed and heart rate were recorded at a rate of 34 Hz, but participants were not informed of any performance results until all trials had been completed. Data for each parameter was subsequently averaged over distance quartiles for all analysis. After a 10 min warm-up at 70% of maximal heart rate (as determined in the maximal incremental test) followed by a 2 min rest period, participants were reminded to complete the TT in the fastest time possible at maximal effort, as they would in a race. Water was consumed *ad libitum* and volume recorded during each TT with no other drinks, gels or solids permitted and participants' fluid intake between trials demonstrated suitable conformity. A standing floor fan (Clarke CAM5002, Essex, UK) was consistently positioned to the frontal side of the participants and offered to minimise thermal stress. The preferred setting for each individual was standardised across trials, not exceeding $167\text{m}^3/\text{min}$ (Jeukendrup et al. 2008).

The software allowed previous performances to be set as a 'pacer' in subsequent trials where a virtual avatar is projected during the course of the trial, alongside the participants' current performance. The presence of a visual pacer has been used in previous research investigating the effects of previous experience (Stone et al. 2012) or competitors (Corbett et al. 2012) on cycling performance. However, no prior studies have depicted a participant's exact pacing profile as a virtual pacer, using instead a fixed work-rate pacer which is set at the power output or speed corresponding to the average values achieved in a previous trial. Consequently, previous studies have been limited in their ability to provide athletes with sensitive enough feedback relating to their pacing profile and how it fluctuates throughout their performance. The investigation of how previous performance knowledge effects pacing decisions has thus far not captured the true nature of pacing dynamics during self-paced exercise.

The CompuTrainer Ergometry software allows previously saved performances to be presented as a visual avatar in subsequent trials but accurately depicts the non-monotonic profile of speed over the course of the trial. This provides the cyclists with continuous feedback of their previous performance, exactly as they rode it. In trials where this pacer was manipulated, for example when participants were exposed to a deceptive intervention (Chapters 4 and 5 for further details), this pacer was set at 102% of their previous performance which similarly replicated their performance profile but was 2% faster throughout. During these 'pacer' trials, the distance between the participants' avatar and the pacer was displayed onscreen in addition to total distance covered, and the drafting function was disabled (Figure 2.1).



Figure 2.1 Representation of the visual feedback provided to participants during the PACER trial.

2.10 MEASUREMENT TECHNIQUES

2.10.1 Perceptual Responses

Verbal and written instructions for each measure were repeated to participants prior to each trial and they were asked to provide verbal confirmation of their understanding. All perceptual responses were recorded at each distance quartile, with the scales presented to participants in large font on laminated A4 paper.

2.10.1.1 Willingness to Invest Effort

Perseverance in a physical task has been found to be strongly predicted by task-specific cognitive variables including readiness to invest effort (Tenenbaum et al. 2005). Willingness to invest physical and mental effort were assessed prior to each trial on separate 100 mm visual analogue scales with the extremes of the scales anchored with the text ‘not willing at all’ (0) to ‘fully willing’ (10) (Tenenbaum et al. 2005; Tenenbaum, Hall and Calcagnini 2001).

2.10.1.2 Perceived Exertion

Perceived exertion has been most commonly measured using Borg’s (1970) 6-20 Ratings of Perceived Exertion scale and is widely considered to be a key mechanism

involved in exercise regulation, as previously discussed (Chapter 1). Verbal anchors were displayed across the scale from 6 (no exertion at all) to 20 (maximal exertion). The RPE is a subjective measure encompassing the physical and psychological components of the exertion and strain experienced during exercise and has been previously validated (Borg 1987; 1982). Participants were familiarised with the use of the RPE scale during the maximal incremental test.

2.10.1.3 Affect

Affective valence was measured in each study using the validated 11-point Feeling Scale (Hardy and Rejeski 1989). Verbal anchors are presented at every odd integer and at zero (-5, very bad; -3, bad; -1, fairly bad; 0: neutral; +1, fairly good; +3, good; +5, very good). Participants were informed that their responses should reflect the affective or emotional sensations experienced during the exercise, reflecting mood and feelings of pleasure/displeasure, and not the physical sensations of effort or strain. The scale was presented to participants at rest and at each distance quartile during the TTs. Hardy and Rejeski (1989) have previously validated this scale and also demonstrated that the FS and RPE are related but not isomorphic constructs, supporting that what we feel during exercise can be differentiated from how we feel. Additionally, the findings of weak to moderate correlations between pre-task, during-task and recall affective valence further highlights the need to measure affect during an exercise bout and not simply as a pre and post measurement as used previously (Sanchez, Boshker and Llewellyn 2010; Treasure, Monson and Lox 1996).

2.10.1.4 Self-Efficacy

Similar to affective valence, self-efficacy expectations are dynamic in nature and will alter with the experience of the situation, thus pre and post assessments are limited in their ability to explain the temporal fluctuations that occur throughout an exercise bout (Welch, Hulley and Beauchamp 2010). Furthermore, expectations are highly specific to the particular behaviour that is being assessed therefore they

should relate directly to the context or situation of the given exercise (Resnick and Jenkins 2000).

Two scales were used to assess perceptions of task-specific self-efficacy; one presented prior to the trial and one during the trial. The scales were adapted from Welch, Hulley and Beauchamp (2010) and were developed in accordance with the guidelines for creating self-efficacy scales (Bandura 2005). The pre-trial scale required participants to rate their level of confidence in their ability to perform in the forthcoming trial, and the during-trial scale recorded the participants' confidence in their ability to perform throughout the trial. During studies 2 and 3, an additional measure of self-efficacy was recorded to assess participants' confidence to compete with the pacer that was presented in the trial as an avatar. This was measured by an additional scale, both prior to and during the trial and was termed *'how confident are you to compete with your previous performance for the remaining distance of the trial?'* All responses were recorded on a percentage scale from 0% (cannot do at all) 100% (absolutely certain can do). Typically, 100- or 10-point scales have been used to assess levels of confidence in performing a specified task (Hu et al. 2007; Motl et al. 2006; Marquez et al. 2002) and Bandura and colleagues continue to recommend the 0% to 100% continuum.

2.10.2 Physiological Variables

2.10.2.1 Heart Rate

Heart rate was recorded at rest and continuously throughout each TT using a telemetric Polar Team System (Polar Electro, Kempele, Finland). Participants wore a heart rate transmitter belt across their chest and water was applied to the electrodes prior to fitting to enhance the signal detection. The data were interfaced with the CompuTrainer software and downloaded at a rate of 34 Hz, in the same manner as power output, speed and time.

2.10.2.2 Metabolic Gases

Breath-by-breath pulmonary ventilation and gas exchange data were recorded at rest and at each quartile of distance covered using a stationary ergospirometer (Oxycon Pro, Jaeger, GmbH Hoechburg, Germany). Prior to each use, the flow turbine and gas analysers were calibrated using a 3 L syringe and gases of known concentration, respectively. The continuous measurement of expired air, requiring a face mask to be worn throughout the entire duration of the trials, would have prevented the participants from consuming any water and thus altered their usual drinking behaviour. Therefore, a nose clip and mouthpiece were worn for one kilometre intervals during each distance quartile to record expired air intermittently at a 5 s sampling rate. This approach offered an effective compromise between minimising any potential influences on drinking behaviour whilst permitting suitable measurement intervals to quantify the metabolic demands of the bouts. Mean minute ventilation (V_E), pulmonary oxygen uptake ($\dot{V}O_2$) and Respiratory Exchange Ratio (RER) were subsequently analysed in distance quartiles. The Oxycon Pro system has been validated against the gold standard Douglas Bag method and shown acceptable reliability across a range of exercise intensities with a coefficient of variation of 1.2% (Foss and Hallén 2005; Rietjens, Kuipers and Kester 2001).

2.10.2.3 Blood Lactate and Blood Gas Parameters

Capillary blood lactate (BLa) concentrations were assessed and used as an indicator of the energy production from anaerobic glycolysis (Gladden 2008). At high exercise intensities, where lactate production is greater than the rate of removal, an accumulation of lactate also coincides with lowered pH and cellular acidosis therefore it is a commonly measured variable across exercise and clinical research settings. Blood gas measurements were included to identify any changes in acid-base balance as a consequence of the interventions.

Pre and post-trial measures of BLa and blood gases were taken in each trial and in each study. Specific sampling procedures are further described in the relevant chapters. To attain an arterialised capillary sample, which provides an accurate

reflection of acid-base status (Mollard 1994), participants' fingertip peripheral capillary beds were warmed prior to the resting sampling. This required participants to place their hand on a hot water bottle for 2 minutes before the sample was taken. Post-trial samples were taken immediately upon completion of the TT as the participants were still on their bicycle. A disposable automated lancet (AccuCheck Safe-T-Pro Plus, Mannheim, Germany) was used to puncture the site after the sampling area was cleaned with an alcohol wipe. The first drop of blood was wiped away and then the blood gases and BLa samples were collected. For blood gas samples, a 100 μ l capillary tube (Radiometer Clinitubes, Copenhagen, Denmark) was held flush with the wound and filled to be immediately inserted into the blood gas analyser (Radiometer, ABL800, Copenhagen, Denmark); and analysed for pH, partial pressures of oxygen (pO_2) and carbon dioxide (pCO_2) and bicarbonate ($CHCO_3^-$) measurements. Potassium (cK) was additionally measured in the studies discussed in Chapters 4 and 5. This blood gas analyser has demonstrated acceptable reliability (CV = 1.4-2%) (Van Blerk, Coucke and Chatelain 2007) and automatic scheduled calibrations were performed for each of the measured parameters using solutions and gases of known concentrations. Specific BLa sampling techniques are discussed in the subsequent chapters and calibrations of the instruments used were made prior to each trial in accordance with the manufacturer's guidelines.

2.11 STATISTICAL ANALYSIS

Linear mixed modelling techniques were used in the analysis of the experimental studies of the thesis to explore effects of the appropriate factors of each study on repeated-measures dependant variables. Test assumptions were checked for all analyses and where any violations were identified, appropriate non-parametric or correction factors were utilised. Descriptive sample statistics are reported as the mean and standard deviation for normally distributed data and the median and interquartile range for non-normally distributed data.

Random effects were entered into the models where significant and all other factors modelled as fixed effects. Where linear or quadratic responses were evident, factors were modelled as continuous variables, whereas saturated means

modelling was used where these quadratic or linear terms were not plausible. In the saturated means modelling, factors were treated as categorical and various plausible covariance structures were assumed, with the structure that minimised the Hurvich and Tsai's criterion (AICC) value chosen for the final fitted model. In the event of significant fixed main or interaction effects, post hoc comparisons with Sidak adjusted P values were used to identify significant differences between paired means. Where linear or quadratic terms were fitted, post hoc analysis was not able to be performed, therefore to aid clarity and consistency, significant effects are presented in-text in the results sections of each of the experimental studies, but not presented on figures or tables. T-tests were used for all non-repeated measures data. All statistical analyses were conducted using IBM SPSS Statistics 22 (SPSS Inc., Chicago, IL) and two-tailed statistical significance was set *a priori* at $P < 0.05$.

Chapter 3

Distance-dependent Association of Affect with Pacing Strategy in Cycling Time Trials

Parts of this chapter have been published in a peer-reviewed journal.

Jones, H.S., et al. (2014) Distance-dependent association of affect with pacing strategy in cycling time trials. *Medicine and Science in Sports and Exercise*,10.1249/MSS.0000000000000475.

3.1 INTRODUCTION

The mechanisms by which pacing strategy is continually regulated during exercise have yet to be clearly identified, despite receiving considerable attention in the literature (Edwards and Polman 2013; Renfree et al. 2012; Abbiss and Laursen 2008). It has been proposed that continuous streams of sensory information, previous knowledge and experience allow behaviour to be constantly and dynamically modified throughout exercise. This is opposed to isolated processes of action selection and action specification proposed from an information processing perspective (Smits, Pepping and Hettinga 2014). Trade-offs are consequently made between the decision to maintain the current work-rate or to select an alternate behaviour (i.e. to increase or decrease pace). Sensations of fatigue are widely thought to play a significant, if not primary, role in the distribution of work-rate during exercise, but the integrative mechanisms as to how these two processes are linked and how perceptions are coupled with actions to determine behaviour are unclear (Smits, Pepping and Hettinga 2014). One important cue that has been implicated in the regulation of exercise is the conscious awareness of the sensation of fatigue (St Clair Gibson et al. 2006), most commonly measured using Borg's (1970) RPE scale.

Despite its widespread use, the appropriateness of the single-item RPE scale has recently been criticised as an oversimplification of the complex psychophysiological construct of effort perception, and that it is an inadequate measure of the multiple perceptual responses experienced during exercise (Renfree et al. 2014; Beniscelli, Tenenbaum and Schinke 2013; Smirmaul 2012; Hutchinson and Tenenbaum 2006). Recent applications of decision-making theory to pacing (Renfree et al. 2014; Smits, Pepping and Hettinga 2014), further questions the ability of the RPE scale to explain the coupling of perceptions and actions in order to establish behaviour. As RPE encompasses a number of sensations and perceptions arising from exertional tasks, it limits our ability to more specifically determine which perceptual cues are influential to the regulation of exercise intensity.

Swart, Lindsay and Lambert (2012) recently proposed a new methodological approach, which endeavoured to separate perceptions of physical exertion from the sense of effort during maximal and fixed-intensity 100 km cycling TTs, interspersed with 1 km sprints. A dissociation was observed between the two perceptions in the fixed-intensity trial, performed at 70% of the power output produced in the maximal TT, and during the sprints in both trials, suggesting that the physical and psychological perceptions were related yet distinct cues. These findings further support the multidimensionality of perceived exertion and the complex manner in which cues interact to determine performance in exercise of different intensities (Eston et al. 2012; Noakes 2012; 2012b; Hutchinson and Tenenbaum 2006). Unfortunately, the inclusion of interspersed sprints and a fixed-intensity TT in Swart et al.'s (2012) study, may limit the generalisability of the findings to 'real-world' self-paced TT performance, as the trained cyclists were unlikely to have acquired a strong, experience-primed performance template in this exercise bout. Additionally, the intensity of the TT was not the only factor differentiating the trials in Swart et al.'s (2012) study. Research has shown that the physiological demands of self-paced exercise are not comparable to a similar fixed-pace exercise bout (Lander, Butterly and Edwards 2009), therefore, as the submaximal trial was enforced at 70% of the power output produced in the self-paced maximal TT, this may have had a confounding effect on the findings.

The rate of increase of RPE during exercise in laboratory-based environments, where the protocol is often of a prescribed intensity, may differ from conditions in which performance is more externally valid and representative of field or competitive events, i.e. with the intensity controlled by the athlete and external environmental cues present (St Clair Gibson et al. 2006; Parfitt, Rose and Markland 2000). The scalar, monotonic nature of RPE with exercise duration has not been supported in exercise where external factors play a significant role (St Clair Gibson et al. 2006). For example, the influence that competitors have on the intended goals of the exercise, motivation and self-confidence means that at a given pace, RPE can differ depending upon the specific situation and these external factors (St Clair Gibson et al. 2006). Consequently, the findings that these cognitive processes

are able to be separated are produced by a flawed methodological design and it cannot be definitively concluded that the difference in intensity was the direct cause of the distinction found between the two perceptual cues. Whilst some authors have questioned the ability to differentiate these perceptions and measure the relative consciousness of them, no experimental evidence has been provided to either refute or further support the use of these scales. Therefore these findings need to be substantiated under more representative TT conditions using suitably experienced athletes.

Contrary to the argument that RPE is a principle regulator of exercise (Tucker 2009), the psychological construct of affect has been shown to be dissociated from RPE (Eston et al. 2012, Hardy and Rejeski 1989) and proposed to contribute significantly to pacing decisions during exercise (Renfree et al. 2012; Baron et al. 2011). Through previous experience, it is suggested that affective valence influences pacing strategy in relation to the goals and expectations of the task (Baron et al. 2011). Pace is said to be regulated in association with the tolerance of discomfort, with positive and negative affective responses influencing the desirability to maintain or change the exercise intensity (Baron et al. 2011). Studies measuring affect during fixed-intensity exercise (Eston et al. 2012; Hardy and Rejeski 1989), therefore provide no further insight into the ability of affect to explain exercise regulation where complex, decision-making processes are crucial (Renfree et al. 2014).

As the experience of emotions are proposed to be related to goal attainment (Lane, Wilson and Whyte 2011), the role of self-efficacy in pacing has also been discussed as a significant situational social-cognitive variable. Positive emotions have been associated with goal attainment and negative emotions with goal failure, thus ratings of self-efficacy, which convey the level of confidence in achieving the task outcome, may influence the goal-directed regulation of exercise intensity (Smits, Pepping and Hettinga 2014). Affective valence (Ekkikakis, Hargreaves and Parfitt 2013) and effort perception (Hampson et al. 2001) are moderated by different exercise domains (i.e. modality, intensity and duration) and between self-paced and fixed-intensity exercise, hence there is a need for future research to explore the roles of affect and self-efficacy in the decision-making processes involved in self-

paced exercise. Furthermore, whilst an intensity-dependent affect-exercise relationship has been theorised (Ekkikakis, Hargreaves and Parfitt 2013; Kilpatrick, Kraemer and Bartholomew 2007), less is known about the implications of this relationship in self-paced exercise of varying distances.

Despite evidence supporting the importance of the interplay between cognitive constructs and interoceptive cues, such as heart rate and respiratory responses, in the regulation of exercise (Noakes 2012b), a paucity of research has adopted a holistic and multidimensional approach in the investigation of pacing strategies during self-paced exercise. Therefore, the main aim of this study was to examine power output distribution and the associated changes in affect, self-efficacy, perceived exertion, sense of effort and physiological responses during both 16.1 km and 40 km self-paced cycling TTs. It was hypothesised that each of these variables would be associated with power output and that these associations would be dependent upon the TT distance. A secondary aim was to determine whether physical perceptions of exertion can be differentiated from sense of effort during self-paced TTs. It was anticipated that these cues would not be easily differentiated in either 16.1 km or 40 km self-paced TTs.

3.2 METHODS

3.2.1 Participants

Fifteen trained male cyclists volunteered for the study and their characteristics are presented in Table 3.1. The mean relative VO_{2peak} value and peak power were used to classify the group of participants as performance level 3, i.e. 'trained', according to recent guidelines (De Pauw et al. 2013; Table 2.1).

Table 3.1 Mean (SD) descriptive data for participant characteristics.

Age (yrs)	35.3 (8.3)
Height (cm)	178.5 (6.0)
Body mass (kg)	80.0 (11.0)
Absolute PPO (W)	362 (35)
Relative PPO (W/kg)	4.6 (0.6)
Relative VO_{2peak} ($mL \cdot kg \cdot min^{-1}$)	55.2 (8.2)
Absolute VO_{2peak} ($L \cdot min^{-1}$)	4.5 (0.6)

PPO = peak power output; **VO_{2peak}** = maximal oxygen uptake.

3.2.2 Maximal Incremental Test

On their first visit, participants completed a maximal incremental test to exhaustion combining a lactate threshold protocol. Following the 5 min warm up, the resistance was set at 100 W and was increased by 20 W every 3 min with a BLa measurement taken at the end of each 3 min stage. Lactate turnpoint was deemed to have been reached when a sudden inflection in the lactate curve was observed, classified as within a range of 2-4 $mmol \cdot L^{-1}$ (Jones 2007). The 20 W increments were then made every minute, with no further BLa measurements, until the participant could no longer maintain the required power output. Three minute stages have been shown to be a valid and reliable stage duration for determining VO_{2peak} (Bishop, Jenkins and Howard 1998). Lactate threshold data was provided as feedback for the participants but not used for the purpose of this thesis.

3.2.3 Research Design

A prospective observational design was used involving the measurement of power output, affect, self-efficacy, physical perceptions of exertion, sense of effort, heart rate and respiratory gases throughout each 16.1 km and 40 km TT. Participants visited the laboratory on five separate occasions with the maximal incremental test completed on the first. Prior to experimental testing, participants completed 16.1 km and 40 km familiarisation trials, performed in a counterbalanced randomised-order. The familiarisation period also served to accustom participants to the

analytical procedures, including detailed instructions of how to use all scales, with repeated clarification given on each subsequent visit and a check of their understanding. Two different distances, the most commonly ridden TT, were chosen in order to explore the interplay between cognitive constructs and interoceptive cues across differing durations and intensities of TT exercise.

3.2.4 Experimental Trials

Following familiarisation on visits two and three, two experimental TTs of 16.1 and 40 km were completed in a counterbalanced randomised-order on visits four and five. Participants performed each TT on their own bicycle which was fitted to the CompuTrainer cycle ergometer and in the fastest time possible. The CompuTrainer software produced a synchronised graphical avatar, cycling on a virtual course that represented the participants' performance profile throughout the TT.

3.2.4.1 Perceptual Responses

Willingness to invest physical and mental effort was measured prior to each trial along with affective valence and task-specific self-efficacy. The resting self-efficacy measure required participants to rate the level of confidence in their own ability to cycle at a moderate-fast pace for distances of 5, 10, 16.1, 20 and 40 km on a percentage scale from 0% (cannot do at all) to 100% (absolutely certain can do). To measure during-task self-efficacy, only three items were recorded in order to reduce the level of interference, as other psychological measurements were also being collected (Welch, Hulley and Beauchamp 2010). Participants reported their confidence in their ability to continue at their current pace for a further 5, 10 and 20 km and an average value was calculated to produce an overall self-efficacy score. These scales were adapted from Welch, Hulley and Beauchamp (2010). During the TTs, affect was also measured using the Feeling Scale.

Physical Ratings of Perceived Exertion (P-RPE) and Task Effort and Awareness (TEA) scales, adopted from Swart et al. (2012), were used to measure the physical perceptions of exertion and sense of effort, respectively. Borg's (1970) 6-20 RPE scale was modified so that participants were instructed to reflect how heavy and

strenuous the exercise felt, combining all physical feelings and sensations and not include the psychological effort required to continue the exercise. In contrast, a TEA scale that ranged from -4 to -10 was described as a feeling or emotion that represents the psychological or mental effort required to continue at the chosen exercise intensity, reflecting how much attention and difficulty is experienced, as well as the level of consciousness of this effort. Responses for affect, P-RPE, TEA and self-efficacy were recorded at each distance quartile.

3.2.4.2 Physiological Variables

Heart rate was measured continuously throughout each TT and pulmonary ventilation and gas exchange were measured at each distance quartile. The V_E , VO_2 and RER were subsequently analysed. Fingertip capillary BLa (Analox Micro-Stat, P-GM7, USA) and blood gas parameters (pH, pO_2 , pCO_2 , $CHCO_3^-$; Radiometer, ABL800, Copenhagen, Denmark) were analysed prior to each trial.

3.2.5 Statistical Analysis

Descriptive sample statistics are reported as the mean and standard deviation (SD) for normally distributed data and the median and interquartile range (IQR) for non-normally distributed data. Linear mixed models were used to explore the effects of trial (16.1 km vs. 40 km TT distances), distance quartile (25%, 50%, 75%, and 100% of total distance), affect, P-RPE, TEA, self-efficacy, V_E , VO_2 , RER, and heart rate on power output distribution. Covariates, interaction effects, and random effects were entered into linear mixed models separately and only left in the final model if statistically significant. To explore the linear relationships between during-trial affect, self-efficacy, P-RPE, TEA, V_E , VO_2 , RER and heart rate with power output, within-subject correlations were first calculated for each participant for each bivariate relationship and then summarised using the median and IQR. One-sample Wilcoxon Signed Rank Tests were used to test whether the median correlations differed significantly from zero. To assess perceptual responses, a linear mixed model was performed with type of response (P-RPE and TEA) and trial entered as factors, and distance quartile entered as a linear covariate.

3.3 RESULTS

Mean performance times in the 16.1 km and 40 km TTs were $27:58 \pm 2:01$ min and $72:12 \pm 5:39$ min, respectively. Power output was significantly higher in the 16.1 km TT than the 40 km TT and significantly different across distance quartiles as demonstrated by main effects for trial ($F = 8.1$; $P = 0.01$) and quartile ($F = 10.7$; $P < 0.001$) (Figure 3.1 A). Power output in the last quartile was significantly higher than in the other quartiles (25, 50 and 75%) in both the 16.1 km and 40 km TTs ($P < 0.001$). However, no interaction was found between trial and distance quartile ($F = 1.3$; $P = 0.31$), suggesting that pacing strategies did not significantly differ between TTs. Mean values for during-trial physiological variables are displayed in Table 3.2. Significant differences were found for pre- and post-trial measures in both 16.1 km and 40 km TTs for BLa and blood gas variables ($P < 0.05$). No significant differences were found in pre-trial ($P > 0.08$) or post-trial blood parameters ($P > 0.14$) between the two TTs (Table 3.3).

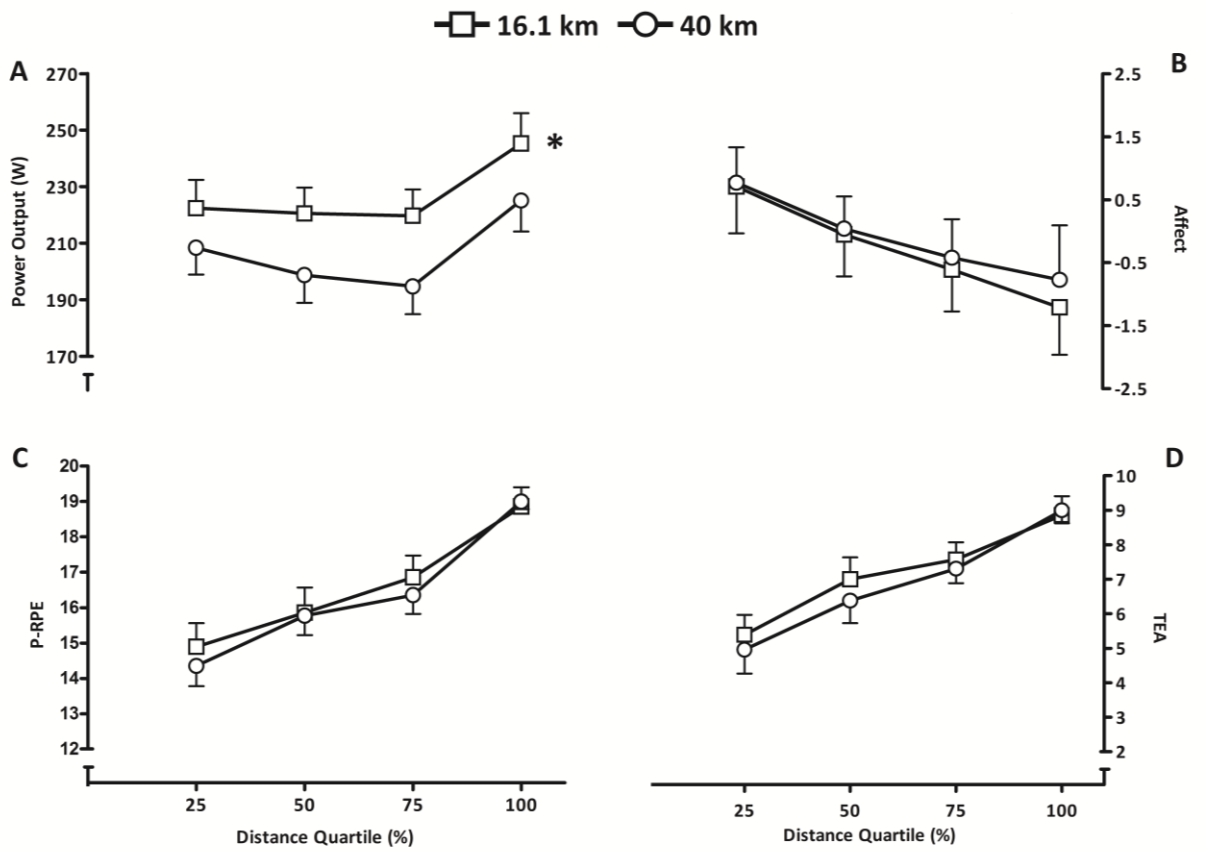

Figure 3.1 Mean (SEM) power output (A), affect (B), P-RPE (C) and TEA (D) across distance quartile in 16.1 km and 40 km time trials.

* denotes significantly greater power output than the 40 km time trial ($P < 0.05$)

Table 3.2 Mean (SD) heart rate, V_E , VO_2 and RER across distance quartile in 16.1 km and 40 km time trials.

	16.1 km					40 km				
	25%	50%	75%	100%	Whole trial	25%	50%	75%	100%	Whole trial
Heart rate (beats·min ⁻¹)	158 (12)	161 (12)	163 (11)	167 (11)	162 (12)	153 (10)	152 (11)	152 (13)	161 (12)	154 (12)
V_E (L·min ⁻¹)	106.5 (19.2)	107.1 (15.6)	111.2 (19.1)	134.1 (26.8)	112.9 (23.0)	95.7 (20.7)	93.3 (22.5)	91.9 (23.9)	123.1 (31.5)	99.8 (27.6)
VO_2 (L·min ⁻¹)	3.7 (0.6)	3.7 (0.6)	3.7 (0.6)	4.0 (0.6)	3.7 (0.6)	3.5 (0.6)	3.3 (0.6)	3.2 (0.6)	3.8 (0.6)	3.4 (0.6)
RER	1.00 (0.04)	0.98 (0.04)	0.98 (0.04)	1.00 (0.07)	0.99 (0.05)	0.99 (0.05)	0.97 (0.07)	0.96 (0.07)	1.00 (0.08)	0.98 (0.06)

V_E = minute ventilation; VO_2 = pulmonary oxygen uptake; RER = respiratory exchange ratio.

Table 3.3 Mean (SD) pre and post-trial blood lactate and blood gas parameters in 16.1 km and 40 km time trials.

		BLa (mmol·L ⁻¹)	pH	pO₂ (kPa)	pCO₂ (kPa)	cHCO₃⁻ (mmol·L ⁻¹)
16.1 km	Pre	1.0 (0.4)	7.43 (0.02)	9.8 (0.8)	5.2 (0.42)	25.1 (1.5)
	Post	5.8 (1.8)*	7.32 (0.04)*	11.6 (1.5)*	4.0 (0.51)*	17.0 (2.0)*
40 km	Pre	1.0 (0.4)	7.41 (0.02)	9.3 (1.3)	5.4 (0.51)	25.3 (1.1)
	Post	5.0 (2.2)*	7.31 (0.04)*	11.4 (1.4)*	4.3 (0.86)*	17.6 (2.9)*

BLa = blood lactate; **pO₂** = partial pressure of oxygen; **pCO₂** = partial pressure of carbon dioxide; **cHCO₃⁻** = bicarbonate.

* denotes significant difference from pre-trial values ($P < 0.05$)

3.3.1 Associations with Power Output Distribution

All during-trial physiological and psychological variables were significantly associated with power output distribution (Table 3.4). The P-RPE, TEA, self-efficacy, and V_E were removed from the linear mixed model, as no main effects or interaction effects were observed for these variables when the other variables were entered into the model. A main effect for affect ($F = 12.1$; $P = 0.001$), and an interaction between affect and trial ($F = 4.5$; $P = 0.037$), indicated that changes in affective valence were significantly associated with power output, but this response was moderated by trial. The negative relationship between affect and power output indicates that a more negative affective valence was associated with a higher power output, and the variables were more closely associated in the 16.1 km than the 40 km TT. Similarly, a main effect was found for RER ($F = 18.1$; $P < 0.001$) and an interaction effect between RER and trial ($F = 8.9$; $P = 0.004$). The RER was significantly positively associated with power output, but the interaction shows that this association was stronger in the 16.1 km than the 40 km TT. Main effects were found for heart rate ($F = 33.5$; $P < 0.001$) and VO_2 ($F = 26.9$; $P < 0.001$), revealing that there were positive associations between heart rate and power output, and VO_2 and power output.

Table 3.4 Median (IQR) within-subject correlation coefficients for the relationships between power output and all exploratory variables.

	Time trial distance	
	16.1 km	40 km
Affect	-0.60* (0.73)	-0.41* (0.74)
Self-efficacy	-0.71* (0.68)	-0.72* (0.54)
P-RPE	0.78* (0.52)	0.63* (0.46)
TEA	0.45* (0.96)	0.44* (0.26)
Heart rate	0.78* (0.63)	0.90* (0.11)
V _E	0.95* (0.22)	0.93* (0.25)
VO ₂	0.89* (0.24)	0.88* (0.23)
RER	0.79* (0.33)	0.88* (1.13)

P-RPE = physical ratings of perceived exertion; **TEA** = task effort and awareness; **V_E** = minute ventilation; **VO₂** = pulmonary oxygen uptake; **RER** = respiratory exchange ratio.

* denotes a significant difference from a median of zero ($P < 0.05$)

3.3.2 Relationship between P-RPE and TEA

Main effects for distance quartile were found for P-RPE ($F = 11.1$; $P < 0.001$) and TEA ($F = 14.6$; $P < 0.001$), indicating that both perceptual responses increased over time (Figure 3.1 C-D). A main effect was found for trial ($F = 6.3$; $P = 0.01$) and on average, responses were significantly higher in the 16.1 km TT (P-RPE: 16.6 ± 2.7 ; TEA: 7.2 ± 2.5) than the 40 km TT (P-RPE: 16.4 ± 2.5 ; TEA: 6.9 ± 2.6). The P-RPE was not significantly different from TEA as no main effect was found for type of response, although it approached statistical significance ($F = 4.1$; $P = 0.053$). Additionally, no interactions were found ($P > 0.23$), suggesting that both P-RPE and TEA scores increase at a similar rate across distance quartile and in both trials (Figure 3.2). Significant random effects were found for intercept ($P = 0.03$) and distance quartile ($P = 0.04$) indicating that there were significant variations between individuals in the degree of perceptual responses at the start of the trials and the rate at which these perceptions increased.

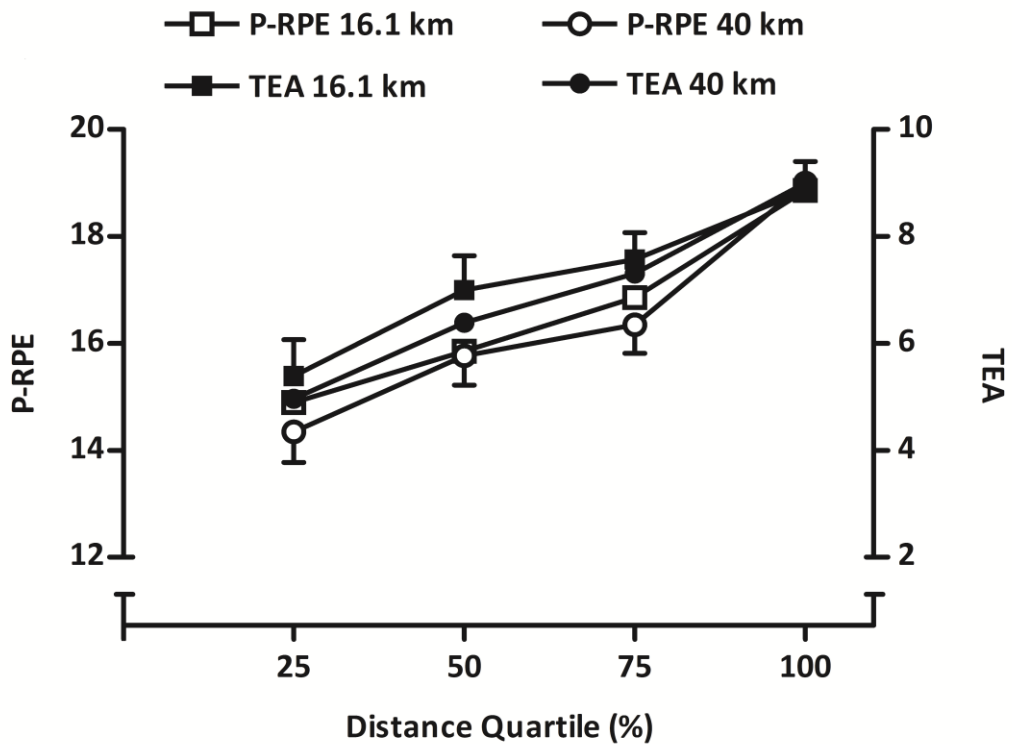

Figure 3.2 Mean (SEM) P-RPE and TEA responses across distance quartile in 16.1 km and 40 km time trials.

3.4 DISCUSSION

The main aim of this study was to examine power output distribution and the associated changes in perceptual and physiological responses during both 16.1 km and 40 km self-paced cycling TTs. The key findings support the hypothesis that all measured variables were associated with power output (Table 3.4), however, affect, VO_2 , RER and heart rate were shown to be the best combination of associated variables. Additionally, power output associations with affect and RER differed in strength between the TTs, with both variables more closely associated with power output in the 16.1 km than the 40 km TT. As expected, the 16.1 km TT was performed at a consistently greater power output and physiological strain than the 40 km TT, as indicated by the accompanying mean differences in heart rate and respiratory gases, but pacing profiles were similar in both trials. A negative pacing pattern was adopted, with a slower start followed by a significantly greater power output, or an ‘end-spurt’, exerted in the fourth distance quartile. No differences in

post-trial BL_a may be suggestive of similar 'end-spurts' in both TTs which corresponds with the absence of power output differences between TTs.

The associations of all measured variables with power output distribution supports the contribution of multiple physiological and psychological processes to the regulation of pacing strategies during self-paced exercise (Baron et al. 2011). The greater association between affect and power output evidenced in the 16.1 km TT in comparison to the 40 km TT, could support theory which suggests that affective responses are intensity-dependent (Ekkekakis, Hargreaves and Parfitt 2013; Kilpatrick et al. 2007), even in exercise of a self-paced nature. This also provides evidence for the significance of this dose-response effect on the relationship between affect and pacing strategy. Interestingly, despite power output being greater in the 16.1 km, this was not accompanied by more negative affective valence, as demonstrated by similar trends in affect in both TTs (Figure 3.1 B). Instead, the stronger association between affect and power output in the 16.1 km TT may be better explained by a distance-dependent relationship rather than an intensity-dependent relationship. Similar to the proposed RPE template (Tucker 2009), with effort perception regulated to increase linearly with the expected distance or duration of the exercise, the importance of a known endpoint may also be applicable to the affect-performance relationship. This association difference between the TTs was also found with RER, which may be a product of the variance of affect that is explained by RER, which is greatest during exercise of a higher intensity (Ekkekakis 2003). Thus, the stronger relationship between affect and power output in the 16.1 km TT, may have been influenced by resultant increases in physiological cues and supports that the associations between the measured variables and power output differed between the TT. These data consequently support the role of affective valence in the regulation of self-paced exercise, extending findings from previous research (Renfree et al. 2012; Baron et al. 2011), and supporting the adjunct measurement of affect to provide clarity pertaining to the complex relationship between affective responses, perceived exertion and performance (Edwards and Polman 2013). On the other hand, self-efficacy was not significantly associated with power output in the model. As self-efficacy and other

cognitive constructs have been shown to have a significant influence on affective responses experienced during exercise (Ekkekakis, Hargreaves and Parfitt 2013), it is therefore suggest that self-efficacy may have an indirect influence on pacing strategy via its determination of affective responses. What remains unclear therefore is the nature of those moment-by-moment cognitions underpinning the resultant affective state.

The second aim of this study was to examine whether physical perceptions of exertion and sense of effort could be differentiated during self-paced exercise. There was a linear trend in the increase of P-RPE and TEA responses and, despite the TTs varying in total distance, the perceptual responses increased as a function of the relative exercise duration and not the intensity or total distance to be completed (Swart et al. 2009b). Although approaching significance, the findings between the P-RPE and TEA scales, including an absence of any interactions, suggests that the physical perceptions of exertion may not be clearly differentiated from sense of effort in either TT distance (Edwards and Polman 2013). These findings support the research hypothesis and are less supportive of previous results in which these scales were utilised (Swart et al. 2012), but the disparity between these investigations may be a function of the varying research designs. Firstly, the use of 16.1 km and 40 km self-paced TTs allowed full decision-making control of pacing behaviours in response to homeostatic challenges during the trials and to prevent deviance from the anticipatorily-set performance template, which would have resulted in suboptimal performance. Secondly, the trained cyclists used in this study will have acquired experientially-developed performance templates from previous exposure to the specific TT distances, and are able to successfully regulate their work-rate in order to prevent the surpassing of acceptable limits of automaticity and resultant rise in severe sensory cues (Edwards and Polman 2013). These differences between the current study and that of Swart et al. (2012) may therefore explain why a significant differentiation between P-RPE and TEA was not found in the present study. Consequently, the role of sense of effort in the regulation of pacing strategies may not provide any additional contribution to self-paced exercise in which individuals have previous experience of performing.

Whilst theory has claimed that perceived exertion is the primary source of exercise regulation, most of these previous studies (de Koning et al. 2011; Tucker 2009) have used the RPE scale whilst the present study adopted a newly proposed, alternative method of measurement; the P-RPE and TEA scales (Swart et al. 2012). This may explain why neither the P-RPE nor TEA were found to be amongst the strongest predictors of pacing strategy in the current study, being left out of the final linear mixed model as they became non-significant when other physiological and cognitive variables were included. Therefore, these findings do not corroborate with previous proposals that these perceptions are the most crucial factors in the regulation of pace (Tucker 2009). The scientific examination of 'consciousness' creates difficulty due to the subjectivity of the phenomenon, which differs between individuals and is entirely unique to the individual experiencing it (St Clair Gibson et al. 2006). This is supported by the finding of significant random effects, indicating variations between individuals' initial perceptual responses and the rate of change of these perceptions throughout the trials. A limitation therefore, of the TEA scale may be the process of asking participants to consciously report a perceptual response that may be unconscious at the time of asking. Vocalisation or conscious signalling of these sensations is said to be associated with the level of conscious acknowledgement of feelings or emotions (St Clair Gibson, Baden and Lambert 2003). Therefore, as with other measurements of perceived exertion, and the arguments surrounding the subconscious or conscious manner in which exertion is perceived (Edwards and Polman 2013), the action itself of prompting participants at set time points during an exercise bout forces attention to these sensations. In this study, no single participant reported feeling unaware of the sense of effort they experienced at any point during the TT, i.e. all responses were positive integers. This supports that placing a verbal prompt on this perception dictates that it becomes conscious and questions the efficacy of quantifying processes deemed to be subconscious. Accordingly, caution is warranted in terms of the use of the P-RPE and TEA scales and more research is needed to determine whether experimentally, more appropriate measures of perceived exertion can be developed.

An observational design was used in this study to investigate the relationships between variables involved in pacing strategy selection without the manipulation of an independent variable which may confound the true nature of these relationships. However, any cause-and-effect relationships from the results discussed should be interpreted tentatively. Future research may wish to explore the use of experimental approaches to further examine these relationships under different exercise conditions.

3.5 CONCLUSION

The results from this study demonstrate that a combination of perceptual and physiological factors are associated with the regulation of power output during 16.1 km and 40 km self-paced cycling TT. The finding of a task-dependant association between affective valence and power output distribution extends support for the role of affect in exercise regulation. Hence, affect warrants future consideration as an important construct of pacing strategies in exercise of varying intensities or distances. Furthermore, a clear dissociation between physical perceptions of exertion and sense of effort was not found in self-paced exercise and is not supportive of the previous study in which the P-RPE and TEA scales were utilised. Together with other recent investigations of the multidimensionality of the construct of perceived exertion, it is hoped that this study will also serve as a catalyst in the exploration of the usefulness of the RPE in our understanding of pacing.

Consequently, these findings provide further rationale for the measurement of affect in the subsequent studies of this thesis but do not support the continued investigation of the P-RPE and TEA scales. They could not be easily differentiated in the mode of exercise utilised in this research and provide no further insight into how pace is regulated during self-paced cycling TTs. More research is warranted to continue to explore the usefulness of the RPE scale as a single item measure, in the meantime, the RPE scale will be used in subsequent studies but will be accompanied with other measures of perceptual experiences.

Chapter 4

**Deception has no Acute or Residual
Effect on 16.1 km Cycling Time Trial
Performance but Negatively Effects
Perceptual Responses**

4.1 INTRODUCTION

Feedback deception has been used as a non-invasive, practical method by which athletes' self-beliefs and expectations of their performance can be manipulated (Stoate, Wulf and Lewthwaite 2012; Hutchinson et al. 2008). The intent is to explore how athletic performance may be optimised through the access of reserve capacities. Beliefs and expectations are often overlooked as to how powerful they can be in the regulation of exercise performance (Halson and Martin 2013), but a recent application of decision-making theories to self-paced exercise draws attention to the key influence of these beliefs (Renfree et al. 2014; Smits, Pepping and Hettinga 2014). The interpretation of feedback (performance, environmental, perceptual) has been associated with expectations during exercise, therefore, by manipulating the feedback that athletes receive, the importance of these expectations can be examined (Renfree et al. 2012).

Some deception studies (Beedie, Lane and Wilson 2012; Wilson et al. 2012; Albertus et al. 2005; Nikolopoulos, Arkinstall and Hawley 2001) have previously demonstrated that pacing strategy and performance are largely unaffected by the provision of incorrect performance feedback during self-paced cycling TTs. As feedback is most influential when it is attended to and evaluated in respect to salient self-goals that hold high importance to the individual (Szalma, Hancock and Dember 2006), the type of feedback that has been manipulated in these previous studies may have limited the effectiveness of the deceptive interventions. This is also supported by the suggestion that feedback must be mediated by previous experience to influence performance (Micklewright et al. 2010). Pacing strategies are said to be based on a pacing 'schema' which is created through prior experience of the given exercise bout and stored in the long term memory to be recalled for future tasks (Mauger, Jones and Williams 2009). In anticipation of and during exercise, this schema is proposed to be evaluated against the current performance to ensure that an optimal pacing strategy is adopted (Mauger, Jones and Williams 2011). Feedback deception is employed in order to create a mismatch in this evaluation and trigger a decision to change behaviour, thus deviating from the learned schema.

A recent study has demonstrated that when athletes were provided with visual feedback of their fastest previous 4 km cycling TT, performance was improved (Stone et al. 2012). Furthermore, when this feedback was manipulated to represent a performance corresponding to 102% of the athletes' fastest baseline, performance time was improved further. Therefore, as participants believed that they were performing worse than their optimal performance, their response was to increase intensity to prevent what they believed would be a suboptimal performance, but instead this allowed them to produce a faster time. Authors attributed these findings to the existence of a reserve capacity even at the end of 'maximal' TT performance (Swart et al. 2009b) and that this reserve was accessed via the manipulation of feedback (Stone et al. 2012). Alternatively, this is also supported by previous motivational theories stating that the presence of competition, in this case a faster self, can improve performance (Vaughan and Guerin 1997; Wilmore 1968).

Whilst some studies have shown that performance can be influenced in trials where deception is acutely employed, others have investigated the residual effect of deception in a subsequent performance (Micklewright et al. 2010; Paterson and Marino 2004). If deceptive feedback is employed to manipulate the learned pacing schema at a subconscious level, then it is of interest to explore whether the alteration to this schema is retained in future exercise bouts. Micklewright et al. (2010) found that the use of intensity deception to elicit a significantly faster start in a subsequent 20 km cycling TT, but this pace was unsustainable, resulting in no differences in overall performance or RPE. Furthermore, a preliminary trial was not performed prior to the experimental deception trial, thus no comparisons could be made with a baseline performance to examine the true residual effects of this deception. In another study (Paterson and Marino 2004), following the deception of distance feedback in 30 km TT, cyclists who unknowingly completed a longer distance in the deceptive trial, performed a subsequent TT significantly faster than at baseline. This perhaps suggests that exposure to deceptive feedback may cause an adjustment to an individual's pacing schema, resulting in an improved subsequent performance, but the underlying mechanisms are unclear. The effects

of deception of previous performance knowledge on a subsequent exercise bout have yet to be fully investigated, despite acknowledgement of the importance of previous experience on performance and pacing strategy (Micklewright et al. 2010; Mauger, Jones and Williams 2009). Therefore, if beliefs of how a previous exercise bout was performed are modified, it may be possible to better understand the role of prior experience in the regulation of pace.

Previous experience might also be an important determinant of subsequent perceptual experiences during exercise. For example, experience of aversive situations and perseverant effort is better able to develop perceptions of self-efficacy than an easily accomplishable task (Hutchinson et al. 2008). Furthermore, the valence of emotions are the product of emotional responses experienced during previous performance accomplishments (Ekkekakis, Hargreaves and Parfitt 2013) and are pertinent to perceptions of self-efficacy (Bandura 1998). Consequently, they are likely to be implicated in future behaviour (Baron et al. 2011). Despite many deception studies suggesting that these perceptual responses may be explicatory of altered pacing strategies and performance (Parry, Chinnasamy and Micklewright 2012), few demonstrate evidence to substantiate these proposals.

The aim of this study was to explore the acute and residual effects of the deception of previous performance knowledge on perceptual responses and performance in 16.1 km self-paced cycling TT. It was predicted that deceptive feedback would influence performance and perceptual responses, both acutely and residually.

4.2 METHODS

4.2.1 Participants

Twenty trained male cyclists/triathletes with race experience in 16.1 km TT volunteered for the study. Match-paired, random allocation was used to allocate participants to either a control (CON_{FBL}) or deception (DEC) group based on VO_{2peak} values and anthropometric variables attained from the first visit (Table 4.1).

Table 4.1 Mean (SD) descriptive data for the CON_{FBL} and DEC experimental groups.

	CON _{FBL} group (n = 10)	DEC group (n = 10)
Age (yrs)	35.4 (7.8)	36.0 (7.6)
Height (cm)	179.7 (5.1)	177.4 (6.8)
Body mass (kg)	81.5 (9)	78.5 (12.1)
Absolute PPO (W)	368 (34)	370 (42)
Relative PPO (W/kg)	4.6 (0.4)	4.8 (0.5)
Relative VO _{2peak} (mL·kg·min ⁻¹)	57.6 (6.7)	58.7 (6.6)
Absolute VO _{2peak} (L·min ⁻¹)	4.7 (0.6)	4.6 (0.6)

PPO = peak power output; VO_{2peak} = maximal oxygen uptake.

4.2.2 Research Design

A 2 x 3 (group x trial) mixed between- and within-subject experimental design was adopted and participants visited the laboratory on five separate occasions. All visits were completed within a maximum 3 week period and the final trial was completed no more than 7 days after the fourth visit. After the initial maximal incremental test, both the CON_{FBL} and DEC groups completed four 16.1 km cycling TTs on visits 2-5 (Figure 4.1).

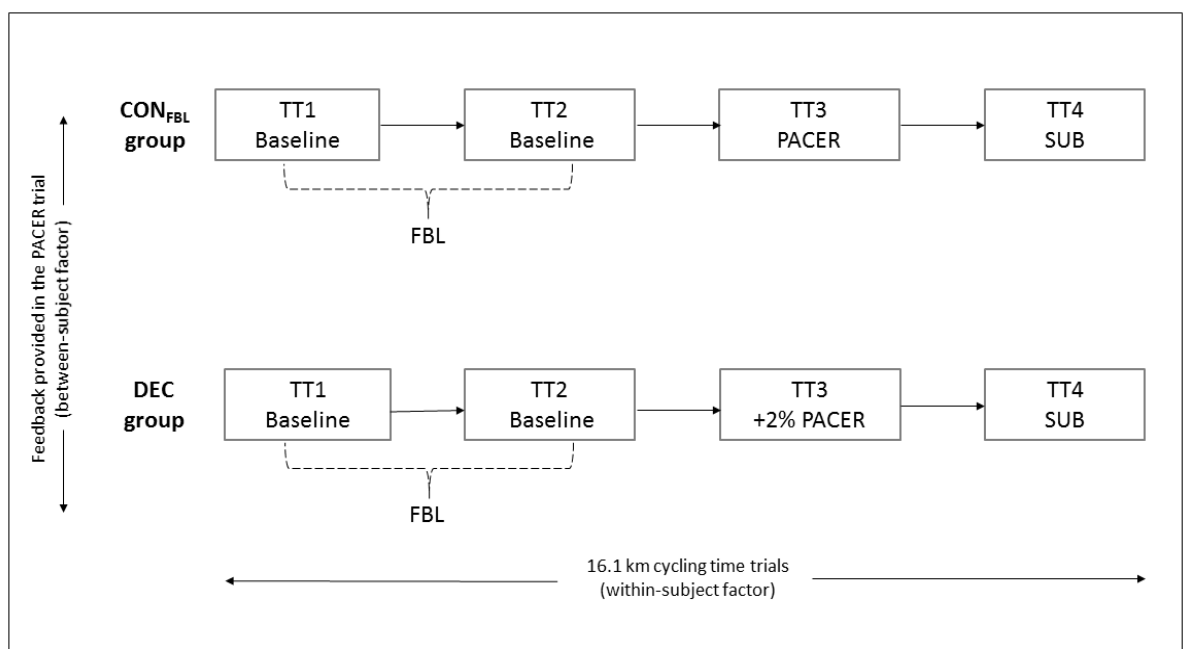

Figure 4.1 Trial schematic of the research design for both CON_{FBL} and DEC groups.

4.2.3 Experimental Trials

Following a maximal incremental test on the first visit, both groups subsequently completed four self-paced 16.1 km TTs. The first and second TTs (TT1 and TT2) were used as baseline performances and each individual's fastest performance from the two baseline trials was classified as their 'fastest baseline' (FBL) and used in all subsequent analysis. In the third TT (PACER), the software represented each participant's FBL performance profile on the screen as a pacer alongside their current performance. In addition to total distance covered, the distance between the participants' avatar and the pacer was also displayed onscreen for both groups. Participants in the CON_{FBL} group were correctly informed that this pacer was their own FBL performance. In contrast, participants in the DEC group were incorrectly informed that the pacer was their FBL performance, however, the avatar's performance corresponded to 2% faster than their FBL. On the final visit, a subsequent TT (SUB) was performed, which was an exact replication of the FBL procedures with no pacer in either group (Figure 4.1).

4.2.3.1 Perceptual Responses

Prior to each TT, participants reported their willingness to invest physical and mental effort, affective valence and self-efficacy, and affect, self-efficacy and RPE were measured during each TT. Affect was measured using the Feeling Scale (Hardy and Rejeski 1989) and RPE using Borg's (1970) 6-20 scale. To assess perceptions of task-specific self-efficacy, participants reported belief of their capability in the task and responses were recorded on a percentage scale from 0% (cannot do at all) to 100% (absolutely certain can do). At rest participants were asked '*how confident are you to cycle at your moderate-to-fast pace for the duration of the trial?*', and during the TT they were asked '*how confident are you to continue at the pace you are currently cycling at for the remaining distance of the trial?*' In PACER, participants were additionally asked to report how confident they were to compete with the pacer for the remaining distance. Affect, self-efficacy and 6-20 RPE scales were presented to participants at each distance quartile, either side of respiratory gas collection.

4.2.3.2 Physiological Variables

Heart rate was measured at rest and continuously throughout each TT and respiratory gas analyser recorded expired air at rest and at every distance quartile. Blood acid-base status (pH, pCO₂, pO₂, cK, and HCO₃⁻; Radiometer, ABL800, Copenhagen, Denmark) and BLa (Lactate Pro, LT-1710, Arkray, Japan) were analysed prior to and immediately upon the completion of each trial. For the BLa sampling, a test strip was inserted into the analyser and a ≈ 5 μL fingertip blood sample was taken. This instrument has been established as a reliable for the assessment of whole BLa and has been validated against other instruments including the Accusport Lactate Meter, the YSI 2300 Stat Analyser and the ABL 700 Acid-Base Analyser (Pyne, Boston and Martin 2000).

4.2.4 Statistical Analysis

Linear mixed models were used to explore the effects of distance quartile (25, 50, 75 and 100%), trial (FBL, PACER, SUB) and group (CON, DEC) on all repeated-measures dependent variables; power output, affect, RPE, self-efficacy, heart rate, V_E, VO₂ and RER. Distance quartile, trial and group were modelled as fixed effects and participant as a random effect. Distance quartile was modelled as a continuous variable where linear or quadratic responses were evident for power output, RPE, V_E, VO₂ and RER. Where saturated means modelling was most appropriate (as linear or quadratic terms were not plausible), distance quartile was otherwise modelled as a categorical variable and various plausible covariance structures were assumed, with the structure that minimised the Hurvich and Tsai's criterion (AICC) value chosen for the final fitted model. Performance times and mean pre- to post-trial changes in BLa and blood acid-base parameters (pH, pO₂, pCO₂, cK and HCO₃⁻) were analysed with fixed effects included for trial and group. Differences between all dependent variables in TT1 and TT2 for both groups were analysed using paired *t*-tests. In the event of significant fixed main or interaction effects, post hoc comparisons with Sidak adjusted *P* values were used to identify significant differences between paired means.

4.3 RESULTS

4.3.1 Performance Variables

A main effect for trial demonstrated significant differences in performance times ($F = 4.8$; $P = 0.018$), with pairwise comparisons indicating that PACER was performed in a significantly faster time than FBL (MD = -21.0 s; 95% CI = -0.68, -0.02; $P = 0.039$) (Table 4.2). Performance time in SUB was not significantly different to FBL (MD = -9.1 s; 95% CI = -0.34, 0.34; $P = 0.13$) or PACER (MD = 11.7 s; 95% CI = 0.14, 0.5; $P = 0.37$). The main effect for group was non-significant ($F = 0.01$; $P = 0.92$) and a significant group x trial difference was also not found ($F = 0.7$; $P = 0.50$), therefore the differences in performance times between trials were similar in both the CON_{FBL} and DEC group.

Power output was significantly different across distance quartile ($F = 59.0$; $P < 0.001$) and between trials ($F = 7.9$; $P < 0.001$), but not between groups ($F = 0.00$; $P = 0.99$). No significant interactions were found for group x trial ($F = 0.08$; $P = 0.92$) or group x quartile ($F = 0.1$; $P = 0.71$). Post hoc comparisons for the trial main effect demonstrated that values were greater in PACER than both FBL (MD = 7 W; 95% CI = 3.83, 10.42; $P < 0.001$) and SUB (MD = 3 W; 95% CI = 0.10, 6.81; $P = 0.042$), and SUB power output was greater than FBL (MD = 4 W; 95% CI = 0.38, 6.97; $P = 0.023$). Pacing strategies in each trial are indicative of a U-shaped profile (Figure 4.2). Significant main effects for speed were found for trial ($F = 6.0$; $P = 0.003$) and distance quartile ($F = 24.0$; $P < 0.001$), but not for group ($F = 0.01$; $P = 0.91$). Similarly, no significant interactions were found for group x trial ($F = 0.9$; $P = 0.42$) or group x quartile ($F = 0.5$; $P = 0.49$). Post hoc analysis for the trial main effect indicated that speed was significantly faster in PACER than FBL (MD = 0.4 km·hr⁻¹; 95% CI = 0.17, 0.61; $P < 0.001$) and SUB (MD = 0.3 km·hr⁻¹; 95% CI = 0.03, 0.48; $P = 0.023$).

Table 4.2 Mean (SD) performance and metabolite responses for the CON_{FBL} and DEC experimental groups.

	Performance time (min:s)	BLa (mmol·L ⁻¹)		pH		pO ₂ (kPa)		pCO ₂ (kPa)		cK (mmol·L ⁻¹)		cHCO ₃ ⁻ (mmol·L ⁻¹)	
		Pre	Post	Pre	Post	Pre	Post	Pre	Post	Pre	Post	Pre	Post
CON_{FBL} group													
FBL	27:10 (2:08)	1.0 (0.3)	8.9 (2.3)	7.41 (0.01)	7.31 (0.05)	10.2 (1.6)	11.6 (1.1)	5.2 (0.2)	4.1 (0.5)	4.9 (0.6)	5.4 (0.5)	25.2 (1.0)	17.2 (3.0)
PACER	26:47* (1:55)	1.0 (0.2)	9.6 (2.3)	7.40 (0.06)	7.32 (0.06)	10.3 (1.3)	11.9 (0.5)	5.0 (0.5)	4.2 (0.5)	4.5 (0.5)	5.2 (0.7)	23.7 (3.8)	18.0 (3.8)
SUB	26:55 (1:58)	1.0 (0.3)	9.0 (2.5)	7.42 (0.01)	7.33 (0.05)	9.1 (3.2)	10.8 (0.6)	5.2 (0.2)	4.3 (0.5)	4.1 (0.4)	5.3 (0.7)	24.9 (1.0)	18.4 (3.0)
DEC group													
FBL	27:00 (1:31)	1.0 (0.4)	9.4 (3.3)	7.41 (0.01)	7.29 (0.06)	10.3 (1.3)	11.9 (1.3)	5.2 (0.3)	4.3 (0.4)	4.1 (0.2)	5.2 (0.4)	24.7 (1.1)	16.6 (3.2)
PACER	26:41* (1:13)	1.1 (0.5)	9.1 (2.8)	7.42 (0.01)	7.30 (0.07)	10.3 (1.2)	12.2 (1.2)	5.1 (0.2)	3.9 (0.7)	4.2 (0.4)	5.3 (0.5)	24.8 (1.0)	16.4 (3.0)
SUB	26:56 (1:38)	1.1 (0.4)	8.4 (2.8)	7.41 (0.02)	7.30 (0.07)	10.9 (0.8)	11.9 (1.6)	5.1 (0.1)	4.1 (0.8)	4.3 (0.2)	5.8 (0.6)	24.3 (1.1)	16.8 (3.9)

BLa = blood lactate; **pO₂** = partial pressure of oxygen; **pCO₂** = partial pressure of carbon dioxide; **cK** = potassium; **cHCO₃⁻** = bicarbonate.

* denotes significantly faster time than FBL ($P < 0.005$)

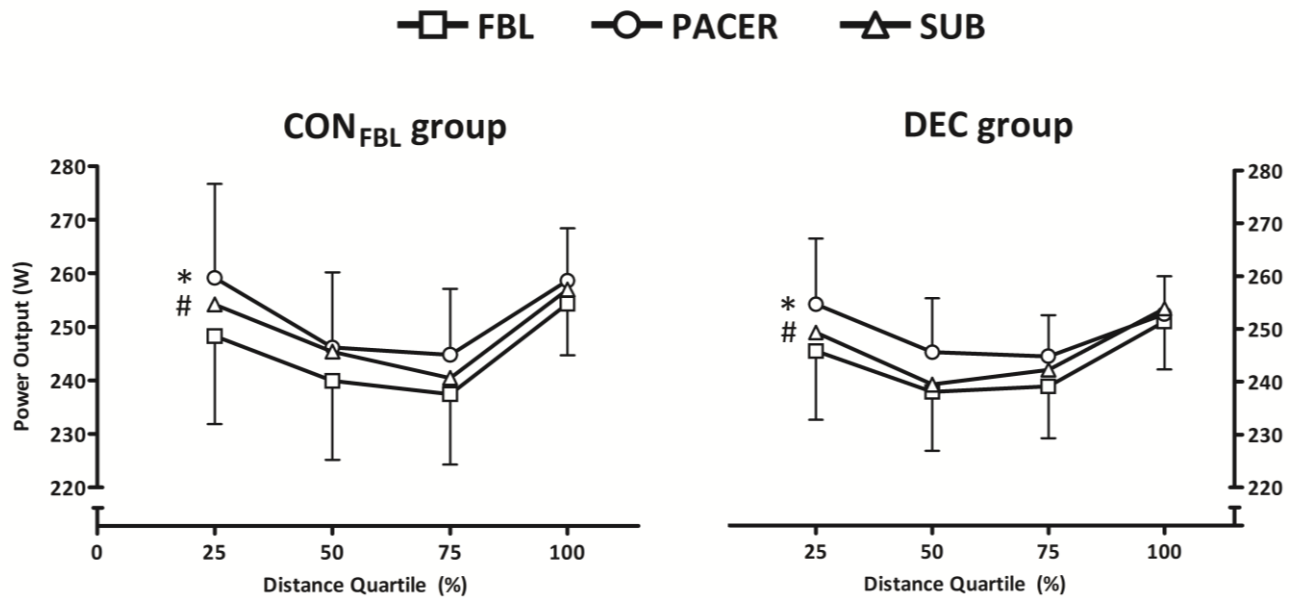

Figure 4.2 Mean (SEM) power output at each distance quartile in 16.1 km time trials for the CON_{FBL} and DEC groups.

* denotes significantly greater power output than FBL and SUB ($P < 0.05$)

denotes significantly greater power output than FBL ($P < 0.05$)

4.3.2 Perceptual Responses

Affect significantly decreased across distance quartile ($F = 18.3$; $P < 0.001$) and differed between trials ($F = 4.1$; $P = 0.027$). A significant group \times trial interaction ($F = 9.5$; $P < 0.001$) revealed that there was a greater reduction in affect during PACER in the DEC group compared with the CON_{FBL} group. This decreased affect in PACER was significantly greater than in both FBL (MD = -1.3; 95% CI = -2.08, -0.50; $P < 0.001$) and SUB (MD = -1.5; 95% CI = -2.26, -0.67; $P < 0.001$) in the DEC group (Figure 4.3 A). A significant trial \times distance quartile interaction ($F = 2.4$; $P = 0.04$) also revealed that at the 75% distance quartile in PACER, affect was lower than FBL (MD = -1; 95% CI = -1.89, -0.01; $P = 0.046$).

RPE significantly increased across distance quartile ($F = 6.6$; $P = 0.019$) and differed between trials ($F = 5.5$; $P = 0.005$). A group \times trial interaction ($F = 3.4$; $P = 0.035$) showed that, in comparison to the CON_{FBL} group, RPE in the DEC group was significantly higher during PACER than FBL (MD = 1.0; 95% CI = 0.55, 1.40; $P < 0.001$) and SUB (MD = 0.9; 95% CI = 0.49, 1.34; $P < 0.001$). In the CON_{FBL} group, RPE was

also significantly greater in SUB compared with FBL (MD = 0.5; 95% CI = 0.05, 0.90; $P = 0.022$) (Figure 4.3 B).

Self-efficacy was significantly differently between trials but only when mediated by group, indicated by a significant group x trial interaction ($F = 5.9$; $P = 0.006$). In the DEC group, self-efficacy was significantly lower in PACER than SUB (MD = -10.8%; 95% CI = -19.9, -1.6; $P = 0.017$) (Figure 4.3 C). In PACER, self-efficacy to compete with the pacer was not significantly different across distance quartile or between groups ($P > 0.14$).

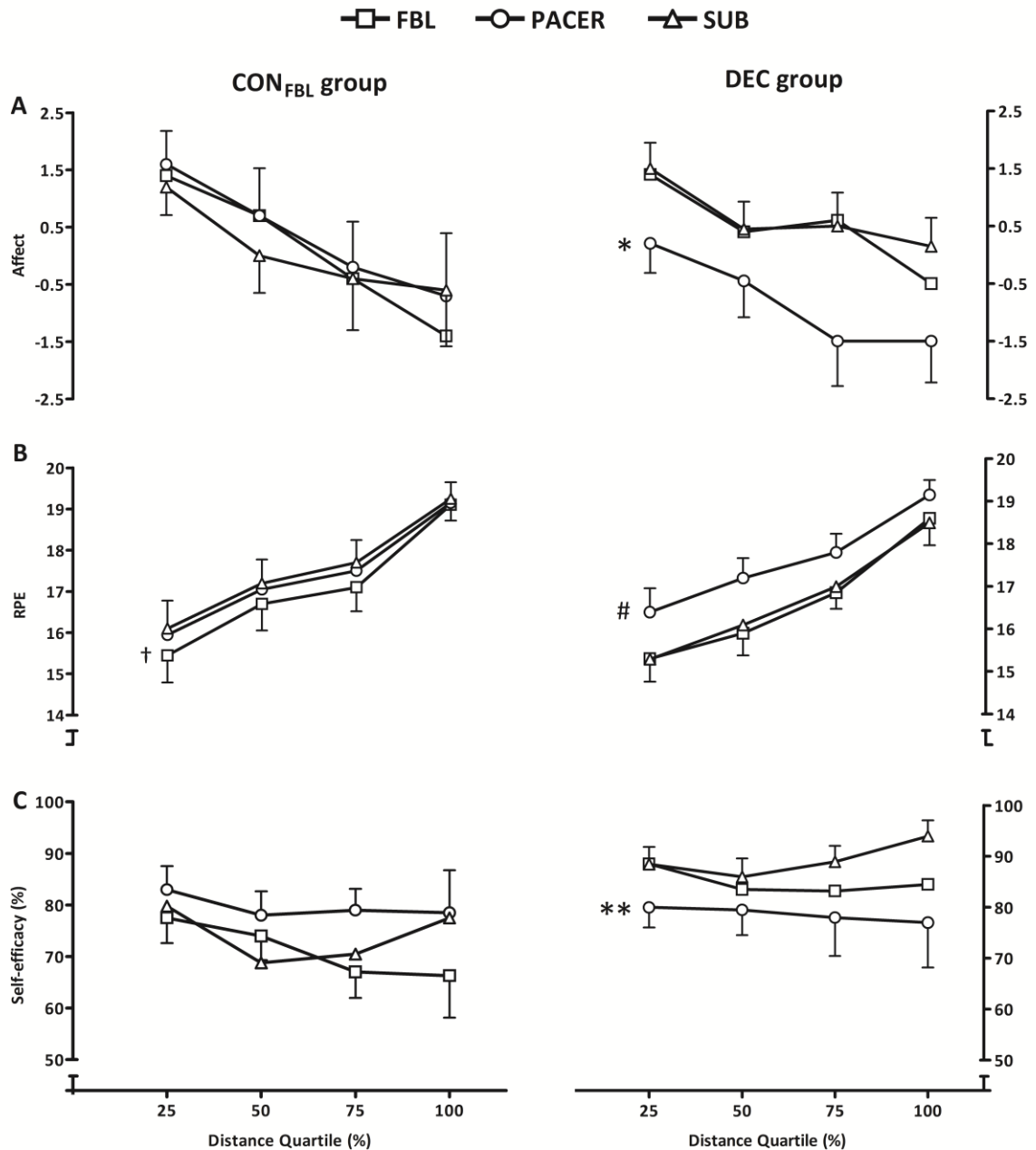

Figure 4.3 Mean (SEM) affect (A), RPE (B) and self-efficacy (C) responses at each distance quartile in 16.1 km time trials for the CON_{FBL} and DEC groups.

*denotes significantly lower affect than FBL and SUB ($P < 0.001$)

† denotes significantly lower RPE than PACER ($P < 0.005$)

denotes significantly higher RPE than FBL and SUB ($P < 0.001$)

** denotes significantly lower self-efficacy than SUB ($P < 0.005$)

4.3.3 Physiological Variables

Heart rate significantly increased across distance quartile ($F = 68.3$; $P < 0.001$) and differed between trials ($F = 3.3$; $P = 0.049$), but the difference between PACER and

SUB failed to reach significance (MD = 2 beats·min⁻¹; 95% CI = -0.05, 4.39; *P* = 0.051). Post hoc comparisons for a group x trial x distance quartile interaction (*F* = 3.3; *P* = 0.01) revealed that heart rate in the DEC group was significantly higher in PACER than SUB at the 50% (MD = 5 beats·min⁻¹; 95% CI = 0.36, 9.2; *P* = 0.03), 75% (MD = 5 beats·min⁻¹; 95% CI = 0.13, 8.96; *P* = 0.042) and 100% (MD = 5 beats·min⁻¹; 95% CI = 0.06, 8.89; *P* = 0.046) distance quartiles. Analysis of the differences in respiratory gases revealed significant distance quartile main effects for V_E , VO_2 and RER (*P* < 0.001), as each variable increased curvilinearly throughout the trials. No group x trial interactions were found (*P* > 0.30) demonstrating that respiratory responses were similar between trials in both groups. No significant differences were found in mean pre- to post-trial changes for BL_a , pH, pO_2 , pCO_2 , cK or HCO_3^- for trial or group (*P* > 0.12) (Table 4.3).

Table 4.3 Mean (SD) physiological responses at each distance quartile in 16.1 km time trials for the CON_{FBL} and DEC groups.

	CON _{FBL} group				DEC group			
	25%	50%	75%	100%	25%	50%	75%	100%
Heart rate (beats·min⁻¹)								
FBL	157 (13)	164 (13)	167 (12)	171 (8)	147 (10)	156 (11)	158 (10)	163 (10)
PACER	157 (15)	164 (13)	167 (12)	163 (9)	149 (12)	158 (12)	161 (12)	164 (12)
SUB	157 (12)	165 (12)	166 (12)	170 (10)	146 (14)	153 (14)	156 (13)	159 (13)
V_E (L·min⁻¹)								
FBL	116.5 (31.7)	114.2 (29.8)	115.0 (25.2)	134.7 (26.4)	116.2 (35.9)	115.5 (31.3)	122.1 (27.5)	147.3 (27.3)
PACER	117.2 (34.1)	119.7 (28.1)	119.9 (24.8)	141.2 (22.8)	121.9 (33.5)	124.0 (31.1)	129.9 (28.0)	147.8 (23.4)
SUB	119.8 (34.1)	119.1 (27.6)	118.2 (24.8)	136.2 (24.1)	118.3 (26.5)	117.7 (24.5)	121.0 (21.4)	141.6 (28.6)
VO₂ (L·min⁻¹)								
FBL	3.8 (0.7)	3.8 (0.6)	3.7 (0.5)	4.0 (0.4)	3.7 (0.7)	3.6 (.06)	3.8 (0.5)	4.1 (0.5)
PACER	3.8 (0.7)	3.8 (0.6)	3.8 (0.5)	4.0 (0.4)	3.8 (0.6)	3.8 (0.5)	3.9 (0.5)	4.0 (0.5)
SUB	3.7 (0.6)	3.7 (0.5)	3.7 (0.4)	3.9 (0.3)	3.6 (0.6)	3.5 (0.4)	3.7 (0.5)	3.9 (0.5)
RER								
FBL	1.05 (0.05)	1.00 (0.05)	1.01 (0.03)	1.05 (0.05)	1.06 (0.05)	1.03 (0.05)	1.04 (0.05)	1.11 (0.07)
PACER	1.04 (0.05)	1.01 (0.03)	1.01 (0.06)	1.06 (0.05)	1.05 (0.05)	1.00 (0.05)	1.02 (0.06)	1.05 (0.05)
UB	1.07 (0.05)	1.02 (0.04)	1.01 (0.03)	1.06 (0.05)	1.04 (0.05)	1.02 (0.04)	1.02 (0.04)	1.06 (0.05)

V_E = minute ventilation; VO₂ = pulmonary oxygen uptake; RER = respiratory exchange rate.

4.3.4 TT1-TT2

Between-group analysis for TT1 and TT2 data revealed no significant differences for mean power output, affect, self-efficacy, heart rate or respiratory gases ($P > 0.05$). Mean RPE in the CON_{FBL} group was significantly higher in TT2 than TT1 ($P = 0.014$), however, this can be assumed to be due to lack of familiarisation as no RPE differences were found between TT2 and PACER. No significant differences were found for pre- to post-trial changes in BL_a and blood acid-base parameters between TT1 and TT2 ($P > 0.05$), except for cK in the DEC group which was greater in TT1 than TT2 (MD = 0.5; 95% CI = 0.08, 0.95; $P = 0.028$). 8 participants performed TT1 faster than TT2 and 12 participants performed TT2 faster than TT1, indicating that learning effects were unlikely.

4.4 DISCUSSION

The aim of this study was to explore the acute and residual effects of the deception of previous performance knowledge on perceptual responses and performance in self-paced 16.1 km cycling TTs. The main findings demonstrate that the provision of previous performance visual feedback is beneficial in the trial in which it is presented, as indicated by increased power output and speed and faster performance times in the PACER trial. These performance improvements are demonstrated regardless of the accuracy of the feedback, suggesting that deceptive feedback has no greater influence than accurate feedback, refuting the study hypothesis. The acute perceptual responses accompanying this improvement in performance, however, are more negative when this feedback is manipulated, which supports the hypothesis. No residual performance effects were demonstrated following the exposure to either feedback intervention as no significant differences in speed or performance time were found in either group between FBL and SUB. A significant residual effect was demonstrated for power output but this was not a large enough increase to influence overall performance time.

Previous research has shown that cycling TT performance can be improved with the provision of visual pacer feedback, which has been attributed to increased motivation and a reduction in internal attentional focus (Williams et al. 2014; Corbett et al. 2012; Stone et al. 2012). As both groups equally improved performance in PACER, this study further supports the notion that cyclists are able to perform faster when riding with a virtual avatar, in comparison to a baseline, ride-alone trial (Williams et al. 2014; Corbett et al. 2012; Stone et al. 2012). Notably, no increases in heart rate, respiratory gases or blood acid-base parameters accompanied the faster PACER performances in either group, which refutes previous conclusions that the access of a physiological reserve was the mechanism responsible for the improvement (Stone et al. 2012). Instead, these improvements may be better explained by an increase in potential motivation, enhancing the athletes' willingness to tolerate effort and enabling a faster performance to be elicited (Marcora 2008). This also supports that a psychological reserve capacity may have been accessed (Baron et al. 2011).

Despite performances not differing between groups, the perceptual responses experienced during PACER were significantly different depending on the accuracy of the feedback provided (Figure 4.3 A-C). The DEC group experienced more negative affect and reported higher RPE scores, whereas these perceptual responses were absent in the CON_{FBL} group. The presence of a virtual competitor has been shown to improve performance but in the absence of elevated perceptions of exertion, which was explained by a reduced internal attentional focus (Williams et al. 2014). This holds true for the results demonstrated in the CON_{FBL} group in the present study, perhaps due to the accurate perception of the pacer's performance, therefore allowing its presence to be facilitative. In the DEC group, the mismatch created in the participants' perceptions may have superseded the facilitative effects of the pacer on perceptual responses and resulted in more unfavourable perceptions of exertion and affective valence, supporting previous findings of increased RPE in a deception trial (Stone et al. 2012). A misinterpretation of the comparison between the current physical state and pre-task expectations may have caused a belief that these interoceptive cues were in excess of expectations. Interestingly, self-efficacy

perceptions in PACER were unaltered in both groups which suggests that the false beliefs experienced by the DEC group may have prevented a reduction in self-efficacy, in accordance with the relationships evidenced between self-efficacy and both affect and RPE (Welch, Hulley and Beauchamp 2010; Hutchinson et al. 2008; Bandura 1997; McAuley and Courneya 1992). Consequently, this may instead support that the greater magnitude of the pacer presented to the DEC group and exposure to more challenging feedback prompted the unfavourable affective and exertional proclivities, not the infliction of false performance beliefs. This also resonates with the findings from Stone et al. (2012), whereby the faster performance demonstrated in the deception condition compared to the control condition could be attributed to either the greater magnitude of the pacer or the experience of false beliefs. Further investigation is thus warranted to explore the importance of each of these factors on both perceptual experiences and performance during self-paced exercise. In summary, an exercise bout in which athletes are provided with manipulated, challenging feedback elicits a faster performance but with accompanying negative perceptual experiences, whereas accurate feedback allows for the same performance improvement but in the absence of these negative responses.

A further aim of this study was to explore the residual effects of previous performance deception with the inclusion of a subsequent TT following the feedback exposure. Neither the CON_{FBL} nor the DEC group were able to significantly improve performance from FBL to SUB, which suggests that accurate and deceptive feedback interventions produce immediate improvements, but these improvements are not likely to be manifested in future exercise bouts. The motivational and attentional facilitation of the presence of the pacer sufficiently altered the pacing schema in PACER, but pace reverted back to the baseline profile once this aid had been removed in SUB. Consequently, this suggests that pacing schemas are not completely rigid in nature and acute variations can be manipulated, however the absence of an enduring change supports the overall robustness of this learned schema (Mauger, Jones and Williams 2010). This is contrary to a previous study in which participants' knowledge of the TT distance

was manipulated and residual performance improvements were found (Paterson and Marino 2004). This may suggest that the deceptive method adopted (i.e. the type of feedback that is manipulated) is an important factor influencing the efficacy of these interventions.

The current study is a novel investigation which explores the effect of deception on multiple perceptual responses, as RPE is typically the only construct measured (Stone et al. 2012; Micklewright et al. 2010; Paterson and Marino 2004). In the DEC group, both affect and RPE responses which were altered in PACER, returned to similar values in SUB as in FBL. This shows that the changes in perceptual experiences when using this particular dose of deception are only acute. Self-efficacy on the other hand, was significantly higher in SUB than PACER in the DEC group whereas it remained unchanged in the CON_{FBL} group. Although no overall residual effects were demonstrated from FBL to SUB, this finding demonstrates that an athlete's confidence appraisals are influenced in the performance which succeeds the exposure to deceptive feedback. In the CON_{FBL} group, a residual effect for RPE was found, with higher SUB values reported compared to those in FBL. The identification of facilitative effects of the pacer via the enhancement of potential motivation, could explain how an increased work-rate was produced in the absence of an increase in RPE in the PACER TT (Marcora 2008). Consequently, without this visual distraction in SUB, a more pronounced discrepancy in perceptions of exertion may have been experienced by this group.

These results provide novel evidence for the acute negative effect of deceptive feedback on cognitive responses, which are not experienced when accurate visual feedback is provided, and opposing residual effects of this feedback on these perceptions. A lack of prior research has investigated the effects of deception on psychological constructs such as affect and self-efficacy, despite support that they may contribute significantly to exercise regulation (Renfree et al. 2012). Furthermore, the one previous study that measured affective valence using deceptive methods, found contrasting results (Taylor and Smith 2014), therefore further research is warranted to explore the role of these perceptual constructs, both during and after deceptive interventions.

4.5 CONCLUSION

This study demonstrates that the provision of previous performance feedback in 16.1 km cycling TTs improves performance regardless of the accuracy of this feedback. Deceptive feedback provided no additional effects on performance beyond that of accurate feedback, therefore the performance improvement may be explained by the motivational aid of the visual feedback. The experience of more negative perceptual responses during the exposure however, suggests that deception results in greater feelings of acute cognitive stress in the absence of changes in physiological strain. Furthermore, neither accurate nor deceptive feedback elicits a residual effect on performance in self-paced cycling TT, suggesting that this single exposure did not alter the athletes' pacing schemas. If feedback interventions are to be employed with athletes in practice, it should be considered that deception which provides challenging feedback is likely to negatively influence perceptual responses, and performance improvements are unlikely to be retained in a subsequent exercise bout. Accurate feedback elicits similar changes to performance, both acutely and subsequently, but without the accompanying attenuation in perceptual responses.

Chapter 5

Effects of Previous Performance Beliefs on Perceptual Responses and Performance in 16.1 km Cycling Time Trials

5.1 INTRODUCTION

Previous studies that have investigated the effects of deceptive strategies during endurance exercise have most commonly explored performance and physiological responses, whilst providing only speculations pertaining to the role of cognitive constructs such as affect and self-efficacy (Corbett et al. 2012; Parry et al. 2012; Thomas and Renfree 2010; Morton 2009). The studies in this thesis, as well as a number of recent investigations, highlight this limitation by measuring affect, perceived exertion and self-efficacy and resultantly supporting their mechanistic contributions to exercise regulation (Taylor and Smith 2014; Renfree et al. 2012). What is still unclear, however, is how the various deceptive techniques affect these constructs with possible factors including the significance of belief effects, the type of feedback manipulated and the presentation of this feedback.

Chapter 4 demonstrated that the presence of a visual pacer that unknowingly represented a performance 2% faster than the athletes' baseline effort improved performance time, but by an equal amount to athletes who knowingly rode against their baseline performance. Differences in affective and exertional perceptions, however, did differ between the groups, supporting the influence of manipulated feedback on perceptual experiences. What could not be ascertained however was whether these perceptual discrepancies stemmed from the difference in the magnitude of the pacer and therefore the challenging nature of the feedback, or the difference in the athletes' beliefs imposed through the deception. Similarly, Stone et al.'s (2012) findings of a faster performance and higher RPE in a deceptive condition may also be confounded by a difference in the pacer's magnitude between the deception and control trials. Accurate beliefs of a faster pacer, equalling the magnitude of the deceptive pacer, may reveal the extent to which deception alone may have influenced their findings of improved performance and the previous findings of perceptual differences in this thesis. Determining which factors drive the nature of these perceptual experiences will allow for a greater understanding of the effects of deceptive feedback and its potential application as a training tool.

The deception of previous performance feedback acts to empower athletes as they believe they are capable of producing a faster performance than they have achieved in the past (Stone et al. 2012). It has been shown that performance can be improved when competing against an opponent whom you believe you are able to beat, but impaired if you perceive the opponent to be better (Weinberg et al. 1981). Contrastingly, a number of studies stemming from motor learning and acquisition research have explored how self-modelling interventions can be facilitative in performance settings and to self-regulatory processes such as motivation and self-efficacy (Ste-Marie et al. 2011; Rymal, Martini and Ste-Marie 2010; Clark and Ste-Marie 2007). A pacer manipulated to be 2% faster than what the athlete has previously been capable of is an example of feed-forward self-modelling which has been shown to elicit performance improvements but inconsistent effects on cognitive processes such as self-efficacy (Ste-Marie et al. 2011; Rymal, Martini and Ste-Marie 2010; Ram and McCullagh 2003). The accurate knowledge that a pacer's performance profile is beyond what they are capable of previously achieving, would therefore explore the significance of an athlete's beliefs in a challenging exercise environment.

The residual effects of deceptive interventions, as previously discussed in Chapter 4, have yet to be fully explored. A residual increase in RPE followed the provision of accurate baseline feedback in the former study in addition to the effect of deceptive feedback on subsequent feelings of self-efficacy support that, whilst no performance effects are evidenced, the type of feedback exposure is influential to perceptual experiences. Mastery experiences, achieved through success in past performances, are thought to most greatly strengthen efficacious perceptions and bring about behaviour change (Hutchinson et al. 2008; Turk 2004, Bandura 1997). An individual's expectancies regarding their abilities in their performance have also been positively associated with motor performance (McKay, Lewthwaite and Wulf 2012), maximal force production (Kalasountas, Reed and Fitzpatrick 2007; Ness and Patton 1979), running efficiency (Stoate, Wulf and Lewthwaite 2012), effort tolerance (Hutchinson et al. 2008), positive affect (Stoate, Wulf and Lewthwaite 2012; McAuley, Talbot and Martinez 1999) and lower anxiety (Marquez et al. 2002).

Interestingly, the more challenging task experienced by the deception group in the previous study in this thesis, and potentially the prevention of positive performance beliefs, did not change subsequent behaviour but did result in more favourable efficacious appraisals in the following TT. It is therefore of interest to explore how the beliefs and expectations of a previous performance can be manipulated, but by creating mastery experiences to investigate the influence of positive expectations on perceptual responses in a subsequent performance.

Research has yet to explore the effects of the disclosure of a deceptive intervention on a subsequent task, but the revealing of an end-point deception half way through an exercise bout has been investigated (Eston et al. 2012; Billaut et al. 2011; Baden et al. 2004). At the point of the reveal, where participants were told to continue exercising for a longer amount of time than expected, more negative affect and higher RPE were experienced (Eston et al. 2012; Baden et al. 2004). This demonstrates that the correction of false belief effects can have acute perceptual implications and justifies the exploration of the residual effects of this disclosure between exercise bouts, as would be more realistic in practical settings. Thus the aim of this study was to investigate the effects of previous performance beliefs on perceptual responses and performance in 16.1 km self-paced cycling TTs. It was hypothesised that acute perceptual responses would be negatively affected by deception, but more positive responses would be experienced in a subsequent trial following a deception reveal.

5.2 METHODS

5.2.1 Participants

Seventeen trained male cyclists and triathletes with race experience in 16.1 km TTs volunteered for the study. Match-paired, random allocation was used to allocate participants to either a control (CON₁₀₂) or deception (DEC_{kno}) group based on VO_{2peak} values and anthropometric variables attained from the first visit (Table 5.1).

Table 5.1 Mean (SD) descriptive data for the CON₁₀₂ and DEC_{kno} experimental groups.

	CON ₁₀₂ group (n = 9)	DEC _{kno} group (n = 8)
Age (yrs)	33.0 (6.0)	37.9 (6.5)
Height (cm)	180.0 (3.1)	178.5 (6.7)
Body mass (kg)	77.2 (5.9)	79.4 (5.4)
Absolute PPO (W)	371 (35)	380 (24)
Relative PPO (W/kg)	4.8 (0.5)	4.8 (0.4)
Relative VO _{2peak} (mL·kg·min ⁻¹)	54.1 (5.9)	53.3 (4.4)
Absolute VO _{2peak} (L·min ⁻¹)	4.1 (0.4)	4.2 (0.3)

PPO = peak power output; VO_{2peak} = maximal oxygen uptake.

5.2.2 Research Design

A 2 x 3 (group x trial) between- and within-subject experimental design was adopted and participants visited the laboratory on five separate occasions. All visits were completed within a 3 week period and the final trial was completed no more than 7 days after the fourth visit. After the initial maximal incremental test (outlined in Chapter 2), both the CON₁₀₂ and DEC_{kno} groups completed four 16.1 km cycling TTs on visits 2-5 (Figure 5.1).

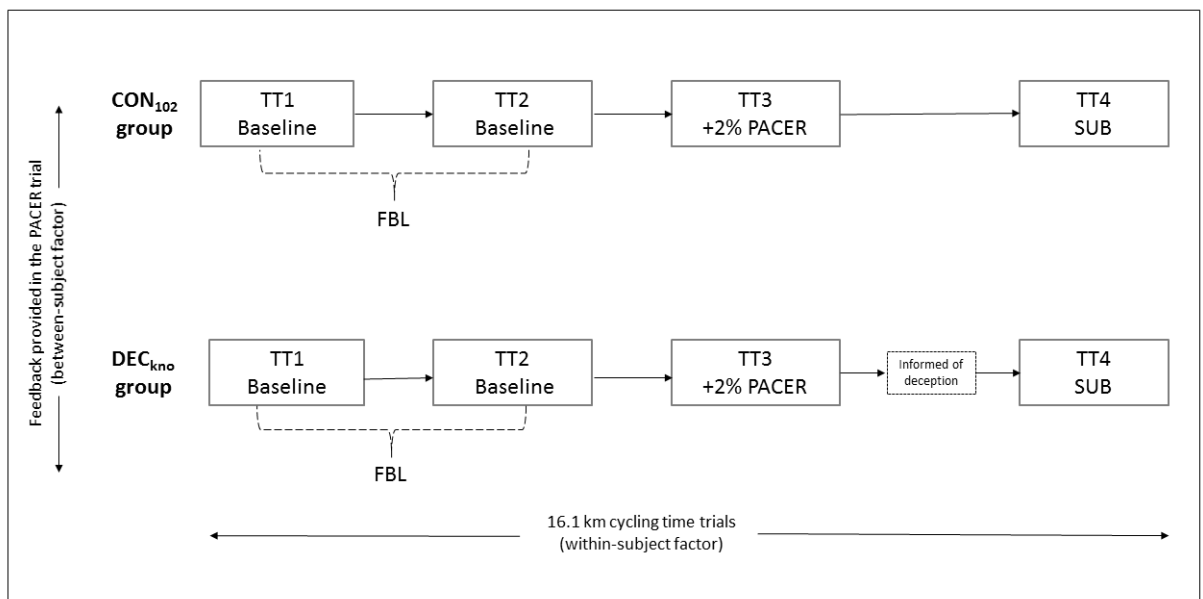

Figure 5.1 Trial schematic of the research design for both CON₁₀₂ and DEC_{kno} groups.

5.2.3 Experimental Trials

The first two TTs (TT1 and TT2) were used as baseline performances and each individual's fastest performance from the two baseline trials was classified as their 'fastest baseline' (FBL) and used in all subsequent analysis. In the third TT (PACER), the software represented each participants' FBL performance profile on the screen as a pacer alongside their current performance. In addition to total distance covered, the distance between the participants' avatar and the pacer was also displayed onscreen for both groups. Participants in the CON₁₀₂ group were correctly informed that this pacer was 2% faster than their own FBL performance. In contrast, the pacer in the DEC_{kno} group also represented a performance corresponding to 2% faster than their FBL but participants were told that it was their actual FBL performance. On the final visit, a subsequent TT (SUB) was performed, which was an exact replication of the FBL procedures with no pacer in either group. Immediately before participants in the DEC_{kno} group commenced their SUB TT, they were informed of the true nature of the pacer that they had performed with in their previous trial. Identical information was given verbally to each participant which stated that the pacer had not represented their fastest baseline TT but had in fact been set 2% faster. No other feedback relating to their performances were provided.

5.2.3.1 Perceptual Responses

Prior to each TT, participants reported their willingness to invest physical and mental effort, affective valence and self-efficacy, and affect, RPE and self-efficacy were measured during each TT. In the SUB trial, the DEC_{kno} group reported these measures prior to receiving knowledge of the deception. Affect was measured using the Feeling Scale (Hardy and Rejeski 1989), RPE using Borg's (1970) 6-20 scale and self-efficacy on a percentage scale of their confidence to maintain their pace (see Chapter 4). In PACER, participants were additionally asked to report how confident they were to compete with the pacer for the remaining distance. The affect, self-efficacy and 6-20 RPE scales were presented to participants at each distance quartile, either side of respiratory gas collection.

5.2.3.2 Physiological Variables

Heart rate was measured at rest and continuously throughout each TT and respiratory gas analysis recorded expired air at rest and at every distance quartile. Samples of BLa (Lactate Pro 2, LT-1730, Arkray, Japan) and blood acid-base status (pH, pCO₂, pO₂, cK, and HCO₃⁻; Radiometer, ABL800, Copenhagen, Denmark) were analysed prior to and immediately upon the completion of each trial. The Lactate Pro 2 analyser requires a ≈ 0.3 μL sample of capillary blood and has superseded the device used in the previous experimental study.

5.2.4 Statistical Analysis

Linear mixed models were used to explore the effects of distance quartile (25, 50, 75, 100%), trial (FBL, PACER, SUB) and group (CON₁₀₂, DEC_{kno}) on all repeated-measures dependent variables; power output, speed, affect, RPE, self-efficacy, heart rate, BLa, V_E, VO₂ and RER. Quartile, trial and group were modelled as fixed effects and participant as a random effect. Distance quartile was modelled as a continuous variable where linear or quadratic responses were evident for power output, speed, RPE and RER. Where saturated means modelling was most appropriate (as linear or quadratic terms were not plausible), distance quartile was otherwise modelled as a categorical variable and various plausible covariance structures were assumed, with the structure that minimised the Hurvich and Tsai's criterion (AICC) value chosen for the final fitted model. Performance times and mean pre- to post-trial changes in BLa and blood acid-base parameters (pH, pO₂, pCO₂, cK and HCO₃⁻) were analysed with fixed effects included for trial and group. Differences between all dependent variables in TT1 and TT2 for both groups were analysed using paired t-tests. In the event of significant fixed main or interaction effects, post hoc comparisons with Sidak adjusted *P* values were used to identify significant differences between paired means.

5.3 RESULTS

5.3.1 Performance Variables

Differences in performance times between trials were statistically significant ($F = 4.9$; $P = 0.015$), with pairwise comparisons indicating that PACER was performed in a significantly faster time than FBL (MD = -17 s; 95% CI = -0.55, -0.01; $P = 0.042$) and SUB (MD = -19 s; 95% CI = -0.59, -0.03; $P = 0.027$) (Table 5.2). Performance time in SUB was not significantly different to FBL (MD = 2 s; 95% CI = -0.24, 0.30; $P = 0.99$). Significant group main effects group x trial difference was not found ($F = 0.7$; $P = 0.49$), therefore the differences in performance times between trials were similar in both the CON₁₀₂ and DEC_{kno} group. Both power output and speed were significantly different across distance quartile (PO: $F = 91.9$; $P < 0.001$, Speed: $F = 29.9$; $P < 0.001$) and between trials (PO: $F = 9.2$; $P < 0.001$, Speed: $F = 7.0$; $P = 0.001$). PACER was performed at a significantly higher power output and speed compared to both FBL (PO: MD = 7 W; 95% CI = 3.17, 10.70; $P < 0.001$, Speed: MD = 0.4 km·hr⁻¹; 95% CI = 0.16, 0.59; $P < 0.001$) and SUB (PO: MD = 8 W; 95% CI = 4.34, 12.03; $P < 0.001$, Speed: MD = 0.4 km·hr⁻¹; 95% CI = 0.19, 0.64; $P < 0.001$). No significant interactions were found for group x trial (PO: $F = 0.4$; $P = 0.69$, Speed: $F = 0.3$; $P = 0.72$) or group x quartile (PO: $F = 0.1$; $P = 0.75$, Speed: $F = 0.001$; $P = 0.97$). Pacing strategies in each trial were therefore similar between the CON₁₀₂ and DEC_{kno} groups (Figure 5.2).

Table 5.2 Mean (SD) performance and metabolite responses for the CON₁₀₂ and DEC_{kno} groups.

	Performance time (min:s)	BLa (mmol·L ⁻¹)		pH		pO ₂ (kPa)		pCO ₂ (kPa)		cK (mmol·L ⁻¹)		cHCO ₃ ⁻ (mmol·L ⁻¹)	
		Pre	Post	Pre	Post	Pre	Post	Pre	Post	Pre	Post	Pre	Post
CON₁₀₂ group													
FBL	26:31 (1:44)	1.1 (0.3)	9.1 (3.3)	7.40 (0.02)	7.30 (0.04)	10.4 (0.8)	10.7 (0.8)	5.4 (0.5)	4.1 (0.4)	4.2 (0.2)	5.6 (0.6)	24.7 (1.0)	16.4 (2.0)
PACER	26:15* (1:31)	1.1 (0.3)	9.7 (3.5)	7.41 (0.02)	7.29 (0.05)	10.1 (1.6)	10.8 (0.9)	5.2 (0.2)	4.3 (0.7)	4.3 (0.3)	5.6 (0.4)	24.9 (1.1)	16.5 (3.1)
SUB	26:40 (1:30)	1.1 (0.2)	9.3 (4.6)	7.41 (0.02)	7.31 (0.05)	9.9 (1.6)	11.3 (0.9)	5.2 (0.2)	4.4 (0.7)	4.2 (0.3)	5.4 (0.5)	24.7 (0.8)	17.7 (3.0)
DEC_{kno} group													
FBL	26:40 (0:52)	1.1 (0.3)	10.8 (5.1)	7.42 (0.02)	7.25 (0.11)	10.1 (0.9)	11.0 (0.9)	5.2 (0.4)	3.9 (0.6)	4.2 (0.3)	5.4 (0.4)	25.2 (1.1)	14.8 (4.2)
PACER	26:22* (0:44)	1.2 (0.5)	12.2 (4.1)	7.41 (0.03)	7.24 (0.07)	9.7 (0.9)	11.2 (0.4)	5.3 (0.3)	3.8 (0.5)	4.4 (0.3)	5.3 (0.2)	25.0 (1.7)	14.0 (2.6)
SUB	26:34 (0:54)	1.1 (0.3)	11 (4.2)	7.41 (0.02)	7.27 (0.07)	10.5 (1.2)	12.0 (0.6)	5.2 (0.3)	3.9 (0.6)	4.2 (0.3)	5.4 (0.4)	24.2 (2.0)	16.3 (3.4)

BLa = blood lactate; **pO₂** = partial pressure of oxygen; **pCO₂** = partial pressure of carbon dioxide; **cK** = potassium; **cHCO₃⁻** = bicarbonate.

*denotes significantly faster time than FBL and SUB ($P < 0.005$)

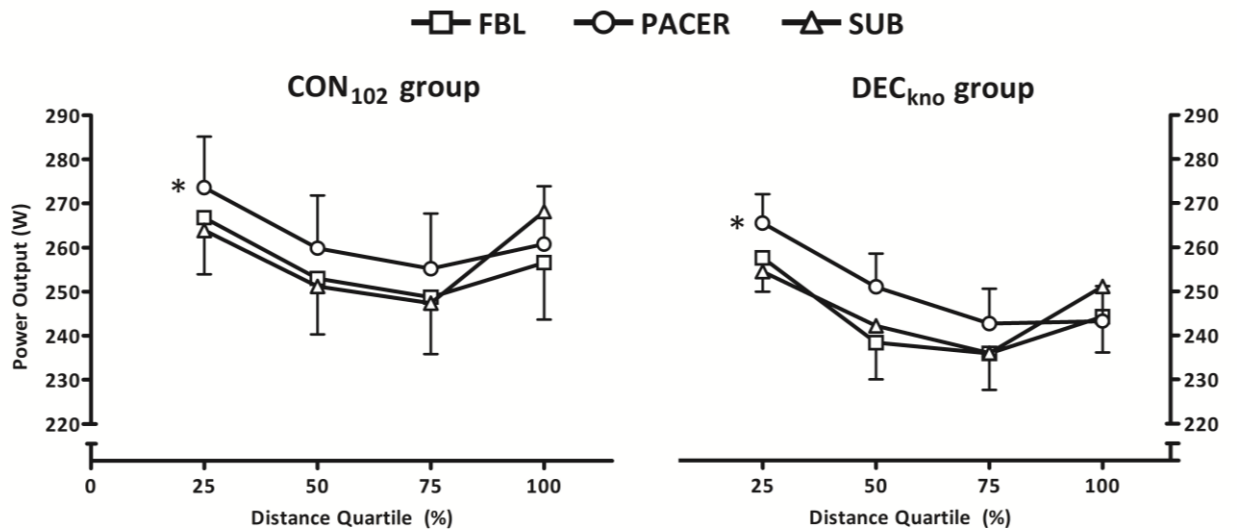

Figure 5.2 Mean (SEM) power output at each distance quartile in 16.1 km time trials for the CON₁₀₂ and DEC_{kno} groups.

* denotes significantly higher power output than FBL and SUB ($P < 0.001$)

5.3.2 Perceptual Responses

Affect significantly decreased across distance quartile ($F = 16.3$; $P < 0.001$) and differed between trials ($F = 4.5$; $P = 0.02$), with significantly lower affect in PACER than FBL (MD = -0.69; 95% CI = -1.28, -0.11; $P = 0.016$) (Figure 5.3 A). RPE significantly increased across distance quartile ($F = 14.1$; $P < 0.001$) and differed between trials ($F = 4.6$; $P < 0.012$). RPE in PACER was significantly higher than in FBL (MD = 0.7; 95% CI = 0.34, 1.04; $P < 0.001$) and SUB (MD = 0.4, 95% CI = 0.07, 0.78; $P = 0.014$) (Figure 5.3 B). For self-efficacy, significant group ($F = 4.9$; $P = 0.042$) and trial ($F = 8.9$; $P = 0.001$) main effects were found, showing that the DEC_{kno} group were significantly less confident than the CON₁₀₂ group (MD = -14.2%; 95% CI = -27.81, -0.55; $P = 0.042$). Self-efficacy was lower in PACER than FBL (MD = -7.6%; 95% CI = -13.76, -1.48; $P = 0.011$) and SUB (MD = -10.0%; 95% CI = -16.13, -3.82; $P = 0.001$) (Figure 5.3 C). In PACER, self-efficacy to compete with the pacer was not significantly different across distance quartile or between groups ($P > 0.16$).

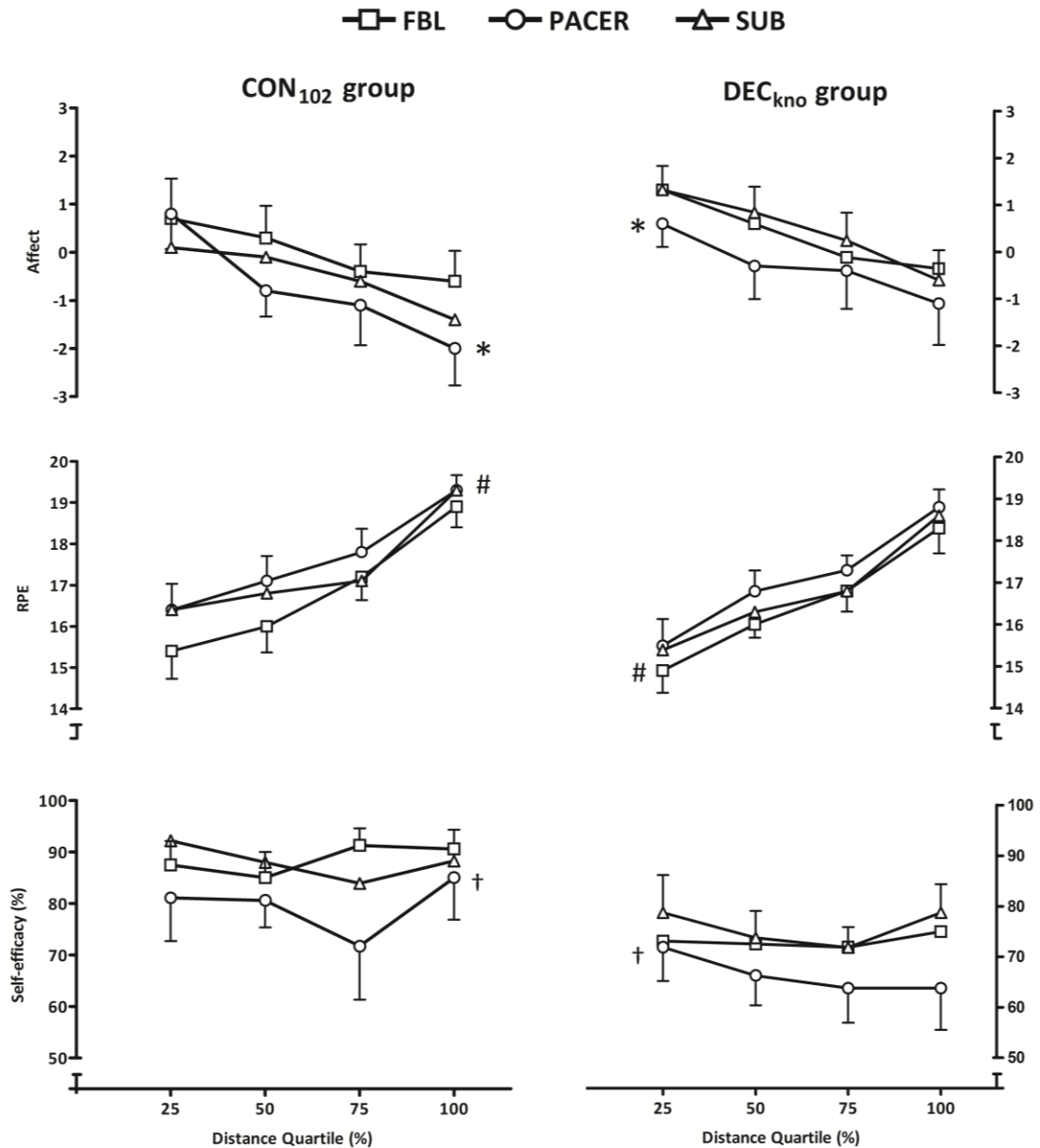

Figure 5.3 Mean (SEM) affect (A), RPE (B) and self-efficacy (C) responses at each distance quartile in 16.1 km time trials for the CON₁₀₂ and DEC_{kno} groups.

* denotes significantly lower affect than FBL ($P < 0.005$)

denotes significantly higher RPE than FBL and SUB ($P < 0.005$)

† denotes significantly lower self-efficacy than FBL and SUB ($P < 0.005$)

5.3.3 Physiological Variables

Heart rate was significantly different between trials ($F = 7.5$; $P = 0.002$) and across distance quartile ($F = 57.7$; $P < 0.001$). Significantly higher values were found in PACER than FBL (MD = 3 beats·min⁻¹; 95% CI = 0.51, 6.44; $P = 0.017$) and SUB (MD =

4 beats·min⁻¹; 95% CI = 1.42, 7.45; *P* = 0.002). Post hoc analysis for a trial x quartile interaction (*F* = 2.7; *P* = 0.036) revealed significantly higher heart rate in PACER than FBL at the 50% distance quartile (MD = 5 beats·min⁻¹; 95% CI = 0.21, 0.57; *P* = 0.021) and in PACER than SUB at the 50% (MD = 5 beats·min⁻¹; 95% CI = 0.51, 8.97; *P* = 0.024) and 75% (MD = 5 beats·min⁻¹; 95% CI = 1.03, 9.51; *P* = 0.01) distance quartiles. Significant distance quartile effects were found for *V_E*, *VO₂* and RER (*P* < 0.001) with additional between trial differences found for *V_E* (*F* = 9.7; *P* = 0.001) and *VO₂* (*F* = 4.0; *P* < 0.029). *V_E* in PACER was significantly higher than in FBL (MD = 9.6 L·min⁻¹; 95% CI = 1.74, 17.50; *P* = 0.012) and SUB (MD = 13.6 L·min⁻¹; 95% CI = 5.37, 21.78; *P* < 0.001). PACER values for *VO₂* were significantly higher in PACER than SUB (MD = 125.8 mL·min⁻¹; 95% CI = 7.77, 243.82; *P* = 0.033) (Table 5.3).

Pre- to post-trial changes in BL_a, pH, pO₂, pCO₂, cK and HCO₃⁻ revealed no significant differences between trials (*P* > 0.08) or group (*P* > 0.26). An exception was found for PO₂ where the CON₁₀₂ group demonstrated higher values than the DEC_{kno} group (MD = 0.8 kPa; 95% CI = 0.06, 1.57; *P* = 0.036). During-trial BL_a however did reveal significant differences between trials (*F* = 6.3; *P* = 0.005), with higher values found in PACER than SUB (MD = 1.6 mmol·L⁻¹; 95% CI = 0.46, 2.72; *P* = 0.003). The PACER to FBL difference was also approaching significance (MD = 1.1 mmol·L⁻¹; 95% CI = -0.04, 2.19; *P* = 0.062) (Table 5.2).

Table 5.3 Mean (SD) physiological responses at each distance quartile in 16.1 km time trials for the CON₁₀₂ and DEC_{kno} groups.

	CON ₁₀₂ group				DEC _{kno} group			
	25%	50%	75%	100%	25%	50%	75%	100%
Heart rate (beats·min⁻¹)								
FBL	157 (14)	164 (14)	167 (14)	169 (13)	145 (8)	154 (13)	157 (14)	160 (14)
PACER	160 (9)	169 (10)	170 (11)	172 (10)	147 (9)	158 (12)	160 (13)	162 (13)
SUB	155 (14)	163 (13)	164 (12)	167 (12)	145 (8)	155 (11)	157 (12)	160 (13)
V_E (L·min⁻¹)								
FBL	120.5 (28.3)	121.4 (30.7)	120.0 (31.0)	138.0 (35.4)	127.5 (33.1)	127.2 (33.8)	127.0 (33.9)	151.6 (32.1)
PACER	131.5 (30.9)	132.4 (35.7)	136.7 (38.7)	143.4 (37.4)	136.9 (35.7)	137.8 (30.6)	137.0 (29.0)	154.5 (21.4)
SUB	120.9 (22.9)	117.5 (25.8)	120.2 (31.6)	147.6 (34.0)	125.6 (25.9)	126.8 (19.4)	125.8 (19.8)	147.1 (23.4)
VO₂ (L·min⁻¹)								
FBL	3.5 (0.5)	3.5 (0.6)	3.4 (0.6)	3.6 (0.6)	3.6 (0.4)	3.5 (0.5)	3.4 (0.5)	3.7 (0.5)
PACER	3.7 (0.5)	3.6 (0.6)	3.5 (0.6)	3.7 (0.6)	3.7 (0.2)	3.6 (0.4)	3.5 (0.3)	3.7 (0.2)
SUB	3.5 (0.4)	3.4 (0.5)	3.4 (0.5)	3.8 (0.5)	3.5 (0.2)	3.5 (0.3)	3.5 (0.3)	3.7 (0.3)
RER								
FBL	1.11 (0.04)	1.12 (0.04)	1.11 (0.04)	1.15 (0.08)	1.12 (0.08)	1.14 (0.08)	1.13 (0.07)	1.19 (0.09)
PACER	1.19 (0.05)	1.15 (0.04)	1.14 (0.03)	1.16 (0.04)	1.20 (0.10)	1.16 (0.10)	1.14 (0.10)	1.18 (0.10)
SUB	1.13 (0.06)	1.09 (0.07)	1.08 (0.07)	1.16 (0.10)	1.21 (0.05)	1.17 (0.04)	1.15 (0.05)	1.20 (0.06)
BLa (mmol·L⁻¹)								
FBL	7.8 (3.3)	8.9 (3.0)	8.7 (2.9)	9.1 (3.3)	10.5 (3.7)	10.4 (4.4)	11.1 (1.5)	10.8 (5.1)
PACER	8.9 (2.4)	8.9 (3.3)	9.4 (3.9)	9.7 (3.5)	11.4 (4.6)	12.1 (5.1)	12.3 (5.3)	12.2 (4.1)
SUB	6.7 (2.6)	6.1 (3.3)	6.6 (4.2)	9.3 (4.6)	10.7 (4.6)	10.7 (4.9)	10.4 (4.8)	11.0 (4.2)

V_E = minute ventilation; VO₂ = pulmonary oxygen uptake; RER = respiratory exchange rate; BLa = blood lactate.

5.3.4 TT1-TT2

Paired t-tests did not reveal any significant differences in either group between TT1 and TT2 for performance time, BL_a, RPE, self-efficacy, V_E, VO₂ or RER ($P > 0.083$). In the CON₁₀₂ group, PO and speed were significantly higher at the 25% distance quartile in TT1 than TT2 (PO: MD = 9 W; 95% CI = 1.2, 18.2; $P = 0.03$, Speed: MD = 0.5 km.hr⁻¹; 95% CI = 0.03, 0.92; $P = 0.038$). For heart rate, significant differences were found in both groups with higher values found in TT1 compared to TT2. In the CON₁₀₂ group, heart rate was higher at the 25% and 50% distance quartiles ($P < 0.008$), and at the 25%, 50% and 75% distance quartiles in the DEC_{kno} group ($P < 0.029$). A significant difference was found in the DEC_{kno} group for affect at the 100% distance quartile, with a higher value found in TT2 than TT1 (MD = 1.3; 95% CI = 0.18, 2.32; $P = 0.028$). Nine participants performed TT1 faster than TT2 and eight participants performed TT2 in the fastest time, indicating that learning effects were unlikely.

5.4 DISCUSSION

This study aimed to investigate the acute and residual effects of previous performance beliefs on perceptual responses and performance in 16.1 km self-paced cycling TTs. The main findings show that both the CON₁₀₂ and the DEC_{kno} groups equally improved performance with the presence of a visual pacer, but no significant between-group differences in affect, RPE or self-efficacy were identified. Furthermore, neither perceptions nor performance were residually affected in either group as no significant differences were found in any variables between SUB and FBL. This supports that the facilitation of a visual avatar has only acute but no residual effects, irrespective of whether the avatar is an accurate representation of a 2% faster profile of an athlete's previous performance or whether the athlete falsely believes that this 2% faster avatar represents their previous performance. Former findings from this thesis (Chapter 4) demonstrated that individuals who perform a TT subsequent to the exposure of this same deception do not perform significantly differently compared to their baseline. The DEC_{kno} group in this study

were informed prior to the SUB TT that their expectations of the avatar in the previous PACER trial were false and that the pacer had been manipulated, yet an absence of residual effects was similarly found.

This study extended the findings from previous studies and from Chapter 4 with the support of acute facilitative effects of visual feedback provision on performance during 16.1 km self-paced cycling TTs (Williams et al. 2014; Corbett et al. 2012; Stone et al. 2012). Both groups performed against the same magnitude of pacer (102% of FBL) but were provided with different instructions and therefore had different pre-exercise beliefs. Findings indicate that the presence of a pacer during cycling TTs improves performance but the accuracy of the feedback provided, and thus the participants' beliefs, had no effect on the extent of this improvement. Furthermore, whilst supporting the hypothesis, physiological and perceptual responses did not differ between groups; RPE, heart rate, \dot{V}_{E} and $\dot{V}O_2$ all increased in PACER and affect was lower, further indicating that beliefs did not influence other variables.

The absence of a difference between the CON₁₀₂ and DEC_{kno} groups contrasts previous research in which deceptive exposures have elicited performance improvements beyond that of a control group (Corbett et al. 2012; Stone et al. 2012), but supports the absence of differences as found in the previous study of this thesis. Stone et al. (2012) highlighted the potentially confounding effect of social facilitation on the findings and acknowledged that an accurately informed group competing against a 102% pacer would reveal the extent to which competition alone may have influenced their findings. The comparable performances of a 102% control group in this study therefore supports that simply the presence of a competitor, and not the expectations of that pacer's performance, is sufficient to evoke a faster TT performance (Weinberg et al. 1981; Weinberg, Yukelson and Jackson 1980; Weinberg, Gould and Jackson 1979). Similarly, this also supports the performance-enhancing effects of feed-forward self-modelling interventions provided via video footage (Ste-Marie et al. 2011; Clark and Ste-Marie 2007).

Previous studies have suggested that videographic feedback enhances performance via its influence on attentional processes (Corbett et al. 2012; Stone et al. 2012), with one study experimentally supporting that internal focus is reduced with the presence of a visual avatar in cycling TTs (Williams et al. 2014). In contrast to this this prior study, RPE increased alongside the improvement in performance in both the CON₁₀₂ and DEC_{kno} groups. Ordinarily, these negative perceptions may have been expected to hinder performance (Matschke, Fehr and Sassenberg 2012; Renfree et al. 2012; Gaudreau, Blondin and Lapierre 2002), but the motivational facilitation of the pacer may have superseded the greater levels of perceived exertion. Furthermore, the enhanced motivation may have been associated with an increase in the cyclists' willingness to invest effort, again allowing performance to be improved in the presence of negative perceptual experiences (Marcora 2008).

The true nature of the deception was revealed to the participants in the DEC_{kno} group prior to completion of the SUB TT. This information acted to correct the false performance belief that they had performed worse in PACER in comparison to their FBL. Similarly, however, performance and perceptions following this disclosure did not vary in comparison to the CON₁₀₂ group or to the DEC group in the previous study, refuting the hypothesis. As demonstrated by the DEC group, both groups in this study also reported higher self-efficacy values in SUB compared to PACER, supporting the successive influence of a challenging exercise bout on confidence appraisals. Positive expectations have been previously shown to benefit performance variables (McKay et al. 2012; Stoate, Wulf and Lewthwaite 2012; Kalasountas, Reed and Fitzpatrick 2007; Ness and Patton 1979) and perceptual experiences (Stoate, Wulf and Lewthwaite 2012; Hutchinson et al. 2008; Marquez et al. 2002; McAuley, Talbot and Martinez 1999), however the absence of between-group differences did not demonstrate that the correction of false beliefs, intended to produce positive expectations and feelings of mastery, influenced cycling TT performance or perceptual variables.

Whilst not statistically significant, there may be value in noting that the change in performance time from FBL to SUB differed in direction between the two groups. The DEC_{kno} group were able to improve from their FBL performance by 6 s (0.4%) in

SUB, comparable with a 4 s (0.3%) improvement from the DEC group in the former study (Chapter 4), whereas the CON₁₀₂ group were actually slower in SUB than FBL by 9 s (0.6%). Task failure frequently evokes pessimistic feelings and self-deflating thoughts which can undermine performance and reduce motivation in subsequent challenges (Brunstein 2000). As only two out of 9 (22%) participants in the CON₁₀₂ group were able to beat the pacer, the performance deterioration in SUB compared to FBL may be explained by this high prevalence of prior failure. Unfortunately, the absence of residual perceptual differences does not act to support this proposition. In summary, the practical implications of feedback provision, either accurate or non-contingent in nature, may be subject to the success or failure of the performance during the exposure and thus is an area warranting further exploration.

5.5 CONCLUSION

The main findings from this study extend support that deception has no additional influence on 16.1 km cycling TT performance or perceptual responses than simply the presence of a pacer. This therefore suggests that the accuracy of the visual feedback provided to athletes and the resultant performance beliefs might be superfluous. Revealing to athletes that their prior performance beliefs were falsely negative due to an exposure to deceptive feedback has no effect on subsequent perceptions or performance.

Chapter 6

General Discussion

6.1 INTRODUCTION

The aim of this chapter is to synthesise the findings from each of the three experimental studies of this thesis, discussing how they relate to existing literature and what original contributions to knowledge they provide. The general discussion of the findings will focus on the effects of deceptive techniques in their application to self-paced endurance exercise, and attempt to conceptualise underpinning theoretical and practical implications. Potential limitations of the research are considered throughout the discussion and recommendations for future research directions are subsequently offered.

6.2 REALISATION OF THE RESEARCH AIMS

The general aims of this thesis were to investigate the mechanistic bases of pacing strategies in self-paced cycling TTs, with the analysis of multiple physiological and perceptual variables. Deceptive methods were employed to manipulate the provision of continuous visual feedback, using the presence of a visual avatar. The methods adopted possessed higher external validity than much of the previous research in this topic with the use of competitive exercise protocols and trained athletes. These deceptive techniques were adopted to examine the influence of beliefs and expectations on pacing strategy, perceptual experiences, physiological responses and overall performance. The manipulation of feedback pertained to the athletes' knowledge of a prior performance, represented by the simulated avatar, in order to explore the importance of previous experience on these variables. The residual effects of the deception and false performance beliefs were analysed to investigate the global, enduring effects of this type of intervention and, consequently, the potential practical implications.

Study 1 demonstrated that affective valence was strongly associated with pacing strategy during cycling TTs, more significantly so in TTs 16.1 km in distance, which consequently rationalised the further investigation of these mechanistic principles using this particular distance rather than 40 km TTs. The findings support the recent proposal for a more integrative mechanistic investigation of the variables involved

in pacing behaviour during endurance exercise and a greater consideration of cognitive processes. The subsequent two studies of the thesis thus continued to adopt an integrative approach to the mechanistic exploration of exercise regulation and studied the effects of deceptive methods which intended to manipulate perceptual experiences and assess the accompanying influence on performance variables.

Participants in the four groups from studies 2 and 3 all performed three experimental TTs (FBL, PACER, SUB), with the presence of a pacer in the second trial. CON_{FBL} received accurate feedback that the pacer represented their FBL performance, CON₁₀₂ were accurately informed that the pacer was set 2% faster than their FBL, and DEC and DEC_{kno} were both incorrectly informed that the pacer represented their FBL when it was in fact set 2% faster. Accordingly, the two groups included in study 2 were provided with the same instructions pertaining to what the pacer represented, but the actual pacer differed (i.e. 100% of FBL in CON_{FBL} and 102% in DEC), and the groups in study 3 received different instructions regarding the pacer, but the pacer was the same (i.e. 102% in both CON₁₀₂ and DEC_{kno}). Furthermore, all groups completed a subsequent ride-alone trial but the DEC_{kno} group were informed of the nature of the pacer deception prior to performing this final trial. This research design allowed for the exploration of both acute and residual effects of deception, aiming to a) extend the findings of current deception studies which have most commonly explored acute effects, and b) provide novel insight into the residual effects of a previous performance deception in self-paced cycling TTs. Accordingly, the ensuing discussion will focus first on the acute findings of the studies and then on the residual findings.

The main findings of these studies showed that acute improvements in 16.1 km cycling TT performance were demonstrated in the PACER trial compared to the FBL, with faster performance times, higher power output and increased speed observed. As all groups elicited similar improvements in this trial, this suggests that no matter what instructions were provided regarding the pacer or the respective magnitude of the pacer's performance, the presence of a virtual cyclist was facilitative to TT performance. The perceptual experiences during the feedback exposure, however,

did vary between groups, indicated by differences in affect, RPE and self-efficacy. The belief that the pacer was an accurate depiction of a previous accomplishment preserved perceptions of self-efficacy, but when the magnitude of this pacer was in fact greater, affective valence worsened and perceptions of exertion were higher. Secondly, there were no significant changes in performance time from FBL to SUB in any group, indicating that no residual effects occur as a result of feedback provision or the deception of this feedback. A residual effect for RPE with athletes who were provided with accurate, less challenging feedback was the only residual perceptual effect found.

6.3 MAIN DISCUSSION

6.3.3 Acute Effects

The first focus of this discussion concerns the acute effects of deceptive feedback provision, considering the acute changes from FBL to PACER TTs. As previously outlined, performance times for all four groups were significantly faster when they performed a TT with visual previous performance feedback. This change in performance time, however, did not differ between the groups, as indicated by the range of FBL to PACER improvements falling between 1 and 1.3% (16-22 s). As the groups received different instructions regarding the pacer and performed against varying pacer profiles, it could be concluded that neither the beliefs nor the magnitude of the pacer had additional facilitative or debilitating effects on performance. Between-group differences in the perceptual responses experienced during the PACER TT did differ depending upon the beliefs and pacer magnitudes, details of which will be subsequently discussed.

A number of other studies have similarly failed to evidence significant performance benefits from deceiving athletes during endurance exercise (Taylor and Smith 2014; Beedie, Lane and Wilson 2012; Wilson et al. 2012; Faulkner, Arnold and Eston 2011; Albertus et al. 2005; Nikolopoulos, Arkinstall and Hawley 2001). In contrast, some studies have demonstrated that performance can be improved significantly through the manipulation of deceptive feedback (Corbett et al. 2012; Parry, Chinnasamy and

Micklewright 2012; Stone et al. 2012; Thomas and Renfree 2010; Morton 2009). As highlighted in Chapter 1, the vastly different methodological designs limit the ability to extricate the key mechanisms for these performance outcomes. The incongruent results displayed between the results in this thesis and that of Stone et al.'s (2012) study are particularly pertinent as similar research designs were adopted. The study from Chapter 4, comprising the CON_{FBL} and DEC groups, is comparable to the two group design used in Stone et al.'s (2012) study, which also provided visual feedback of either a 100% or 102% previous performance pacer. Their study, however, chose 4 km TTs and the pacer was set at a fixed-intensity throughout the trial; representing the individuals' average power output from their previous performance. The pacer used in this thesis, in both control and deception conditions, represented the exact speed profile of the athletes' prior performance, enabling a more reflective interpretation of their previous efforts. Speed and power output are not linearly related, thus by using a speed to power ratio of 1:2.9 (Flyger 2008) it can be calculated that the 2% increase in speed applied to the pacer equates to a 5.8% increase in power. This is greater than the 2% power output magnitude used in Stone et al.'s (2012) study which only equates to a 0.7% increase in speed. Consequently, the magnitude of the pacer may be an important factor in the provision of manipulated performance feedback and the absence of significant between-group differences in these studies may be due to the magnitude being too great. This corroborates with Micklewright et al. (2010) who found that pacing strategy in a subsequent trial following a 5% speed (or equivalent 14.5% power output) deception was initially increased but could not be maintained.

Competing against an opponent constitutes social facilitative effects; therefore the presence of the visual avatar may have superseded the effects of false beliefs and any resultant adverse patterns in perceptual responses. Experiences of negative cognitions, perhaps due to reduced competency, lower expectations or goal discrepancy, may have been expected to hinder performance (Matschke, Fehr and Sassenberg 2012; Renfree et al. 2012; Gaudreau, Blondin and Lapierre 2002), but the facilitative motivational effects of the visual pacer may have negated such performance decrements. This indicates that beliefs may not be a primary

mechanism of exercise behaviour and tolerance in 16.1 km cycling TTs, and that motivational factors based on real-time feedback are more prevalent. This is further supported when the athletes' willingness to invest effort is considered. The presence of the pacer and accompanying performance feedback may have increased levels of potential motivation, enabling task engagement and therefore pacing decisions to be enhanced (Marcora 2008). This motivation, combined with the expectation that they were capable of achieving the performance, may have resulted in the cyclists' decision to accept a higher RPE and more negative affect based on the belief that it would be a successful strategy (Micklewright et al. 2010).

Both intrinsic (previous performance feedback) and extrinsic (presence of a competitor) motivational aids have demonstrated these facilitative effects on performance (Williams et al. 2014; Corbett et al. 2012; Stone et al. 2012). On the other hand, neither extrinsic monetary rewards (Hulleman, de Koning and Hettinga 2007) nor non-visual performance feedback (Taylor and Smith 2014; Micklewright et al. 2010) have resulted in significant performance improvements. Hence this further supports that it is the visual nature of the performance feedback, either intrinsic or extrinsic in nature, which provides sufficient motivational benefits (Robergs, Bereket and Knight 1998). This may be because the most effective reactions to feedback occur when the information relates to salient self-goals and when it is attended to, which may have been encouraged due to the visual nature of its provision (Szalma et al. 2006). Another prospective mechanism as to how this visual feedback may have improved performance is that of attentional focus, with video footage being previously shown to shift an internal focus of attention to external cues (Mestre, Dagonneau and Mercier 2011; Barwood et al. 2009). In deception research in cycling TTs, two studies which have used visual avatars and road footage both inferred that a potential mechanism explaining improvements in performance was that of attentional processes and the ability of the avatar to reduce internal focus (Corbett et al. 2012; Stone et al. 2012). The limitation that attentional focus was not experimentally measured in these prior studies was addressed in a recent study using 16.1 km cycling TTs performed with the presence of a visual competitor (Williams et al. 2014). Findings supported that this visual

feedback evoked a faster performance but in the absence of a higher RPE which was credited to a reduced internal attentional focus. The CON_{FBL} elicited this same response and is directly comparable to the group in the aforementioned study where the avatar actually represented their baseline performance (Williams et al. 2014). The other groups in the studies of this thesis, however, experienced higher levels of RPE which suggests that the magnitude of the pacer may have influenced the attentional processes during the exercise. Future research utilising visual feedback provision is thus recommended to consider the role of attentional processes and experimentally measure this construct to investigate the integrative effects of performance feedback and visual aids on performance.

As previously discussed, the study by Stone and colleagues (2012) provides comparative opportunities to determine the influence of deceptive previous performance feedback in cycling TTs. Stone et al. (2012) highlighted that a limitation of their study was that a trial in which participants had accurate knowledge of a 102% avatar was not included. This prevented them from confirming that the differences they found between a 102% deception group and a FBL control group were solely attributable to the deceptive intervention, or whether the competitive environment had a confounding effect. The results from the studies in this thesis, from groups with and without accurate knowledge of a FBL and 102% trial, were therefore able to address this concern. As no differences were found in the improvement in performance time in the PACER trial between groups, it could be concluded that competition alone is sufficient to improve performance and Stone et al.'s (2012) findings may have therefore been confounded by this factor. Their study, however demonstrated more pronounced performance enhancements in the deception condition, which opposes the results from this thesis. Hence, the extent to which pacer presence and magnitude may have convoluted their findings from 4 km cycling TTs remains unclear. This research design also examined the performance-enhancing evidence of self-modelling by encompassing both positive self-review (CON_{FBL}) and feed-forward self-modelling (CON₁₀₂) techniques (Zimmerman 2000). Similarly, the application of self-modelling to this exertional context is supported as both techniques enhanced performance,

but there were no differences in the value of one type of modelling over the other and no enduring effects for either type were demonstrated.

Expectations of success in relation to competitive situations where win/lose outcomes are applicable can be related to the performances in the PACER TTs of these studies. When performing against an opponent whom an athlete perceives they are able to beat, performance has been found to improve (Weinberg, Gould and Yukelson 1981; Weinberg, Yukelson and Jackson 1980; Weinberg, Gould and Jackson 1979). This is supported by improved PACER performances in CON_{FBL}, DEC and DEC_{kno} groups where the participants all believed that the avatar represented their fastest previous accomplishment in the task. The assurance that they were capable of producing the performance represented by the avatar and the added motivational stimulus of visual feedback and a competitive goal may have resulted in the belief that the pacer could be beaten (Tenenbaum et al. 2005). On the other hand, performance is said to be impaired when an opponent is perceived to be unbeatable (Weinberg, Gould and Yukelson 1981; Weinberg, Yukelson and Jackson 1980; Weinberg, Gould and Jackson 1979). The CON₁₀₂ group were aware that the pacer was 2% faster than what they considered to be their maximal effort so may have believed that beating the pacer would be impossible, or at least a significant challenge. However, despite only two out of nine (22%) participants being able to actually beat the pacer, 78% of them were able to perform faster than they did in their FBL trial; supported by significant effects for performance time and thus refuting this theory in this exertional context. It may be that the high levels of tolerance and feelings of empowerment in these trained athletes allowed them to overcome the psychological barriers associated with a faster pacer and were able to improve performance (Stone et al. 2012).

As discussed, no between-group differences in overall performance changes from FBL to PACER were observed, but the perceptual responses experienced during the PACER trial did differ. In Chapter 4, the DEC group experienced more negative affect and higher RPE when riding against a pacer, but the CON_{FBL} group did not respond differently between trials. The groups in Chapter 5 both showed similar patterns in perceptual responses, experiencing more negative affect and higher RPE, which was

comparable to the DEC group (Figures 4.3 and 5.3). When compared to the instructions and actual magnitude of the pacer, the affective and exertional perceptual responses match the pattern of the true magnitude of the pacer, rather than the instructions provided (Table 6.1). This suggests that these perceptions are based on the actual rather than the expected performance of the pacer, therefore negating the importance of exercise expectations.

Table 6.1 Between-group comparisons of the research designs and acute outcomes in the PACER trial.

	Instructions regarding the pacer	Actual magnitude of the pacer	Performance outcome	Perceptual outcomes
Study 2				
CON _{FBL} and DEC	Same	Different	Same	Different
Study 3				
CON ₁₀₂ and DEC _{kno}	Different	Same	Same	Same

Affective influences were not experimentally measured in Stone et al.'s (2012) study, yet the authors advocated the consideration of this cognitive process in exercise regulation due to its potential links with external motivational stimuli (Craig and Norton 2001), effort exertion (Davidson 2004) and RPE (Ekkikakis, Hall and Petruzzello 2005). The findings from Chapter 3, supporting a strong association between affect and power output, along with more recent research supporting this affect-work-rate relationship (Renfree et al. 2012), extend this proposal and further highlight that affective valence may enhance our understanding of psychological mechanisms involved in pacing behaviour during endurance exercise.

The few studies in the field of pacing and deception that have measured affective valence throughout an exercise bout are limited and results are inconsistent. Renfree et al. (2012) proposed that affect may be particularly important to the regulation of pace during endurance exercise when compared to other perceptual

responses. Their study found that a poorer performance with greater levels of physiological strain was associated with more negative affect. This corroborates with the proposal that the more negative affective responses are, the less the desire to sustain the exercise intensity (Baron et al. 2011; Kilpatrick et al. 2007). Alternatively, the CON₁₀₂ and DEC groups were all able to complete PACER in a faster time whilst experiencing the most negative valence, refuting these observations. Results from another recent study, similarly demonstrated that a faster performance was associated with more negative affect (Taylor and Smith 2014). Whilst similarities are evidenced in the direction of the relationship, the studies appear to contrast each other in the way in which the deceptive manipulations altered the relationship strength. Taylor and Smith (2014) found that affective responses did not differ between deception and control conditions whereas the findings from the groups in this thesis showed that variations in the feedback exposure influenced affect responses. In addition, the relationship strength between affect and running speed was weak in both the deception and control trials which again contrasts the findings from this thesis as Chapter 3 demonstrated the prevalence of a strong association between affect and power output during cycling performance. It is interesting that despite the same increase in power output as other groups, affect in CON_{FBL} was not reduced which does not appear to support the findings from study 1 or Taylor and Smith's (2014) study. This could indicate that the association between affect and pace may have differed in strength and the relationship is subject to variation with the employment of manipulative interventions.

Another potential factor which could explain the discrepancies between the aforementioned studies is that of competitive suffering. A 102% pacer in the CON₁₀₂ and DEC groups may have inflicted the observed negative affective responses, which are indicative of a competitive suffering situation (Evans et al. 2014; Bueno et al. 2008). Trained cyclists, as previously discussed, are likely to have developed adaptive coping strategies to manage these negative appraisals; one such strategy proposed to be pace adjustments (Buman et al. 2008). Therefore, the experience of negative affect may have been a precursor to increased power output and speed

and could explain why performance was comparatively improved to the CON_{FBL} group who did not experience this suffering. The lack of clarity in the patterns of affective responses and its associative relationships with performance and perceptual variables during exercise of different intensities and with varying external cues, suggests that the underlying mechanisms of affective processes may be governed by the exercise protocol and environment.

A recent study addressed the complexities of these research designs by directly manipulating affective responses to more clearly ascertain the role of this cognitive process on task engagement (Blanchfield, Hardy and Morree 2014). The study provided novel evidence that affective responses are able to influence perceptions of effort and performance during a time to exhaustion protocol (Blanchfield et al. 2014). The role of affect in self-regulatory processes during endurance exercise appears to be a current and topical direction of research clearly warranting more investigation.

In a number of pacing studies using deceptive methods, RPE changes have been shown to correspond with work-rate or performance changes similarly in both deception and control conditions (Pires and Hammond 2012; Faulkner, Arnold and Eston 2011; Mauger et al. 2010; Albertus et al. 2005; Hampson et al. 2004; Nikolopoulos, Arkinstall and Hawley 2001). Alternatively, the deception of continuous visual feedback has been shown to alter RPE responses when compared to non-deceptive conditions (Parry, Chinnasamy and Micklewright 2012; Stone et al. 2012). Stone and colleagues (2012) showed that post-trial RPE was higher in the DEC group which is comparable to the results from the CON_{FBL} and DEC groups in Chapter 4. On the other hand, the finding that the deception groups and the CON₁₀₂ group all experienced similar increases in RPE suggests that it was not the belief effects of the deception that altered RPE but the magnitude of the pacer. Consequently, it could be anticipated that it was the difference in the magnitude of the exposure in Stone et al.' (2012) study which caused the significant difference in the RPE value. Micklewright et al. (2010) also proposed that an athlete's beliefs, constructed and reinforced by similar previous experiences, are a driver of effort

sensations and, by association, pacing decisions. This proposal is not strongly supported by the results of this thesis, as beliefs were not found to influence RPE.

Interestingly, the trends in self-efficacy perceptions do not corroborate with the affective and exertional perception patterns. Prior theories and experimental evidence support the relationships between self-efficacy, RPE and affect and promote that a higher RPE is associated with more negative affect and lower self-efficacy (Hutchinson et al. 2008; Hall, Ekkekakis and Petruzzello 2005; Pender, Bar-Or and Wilk 2002). The observational trends in these variables support these directional relationships but, in the DEC group for example, affect and RPE significantly changed in the PACER TT yet accompanying significant differences in self-efficacy were not found. Self-efficacy was unaltered in PACER compared to FBL in the CON_{FBL} and DEC group in study 2, and Figure 5.3 C indicates that the significant main effect for lower self-efficacy in study 3 may have stemmed predominantly from the trends in the CON₁₀₂ group. Theory supports that previous performance is the primary determinant of self-efficacy (Bandura 1997) therefore, expectedly, the athletes' beliefs in the CON_{FBL} and DEC groups that they were capable of the performance exhibited by the avatar meant that self-efficacy was unchanged. The CON₁₀₂ group was, however, the only group to believe that they were performing against a pacer that was beyond their capabilities, which resulted in the greatest reduction in self-efficacy. These results suggest that belief effects were significant in the manipulation of perceptual experiences during the trials, but only to feelings of efficacy. Bogus negative feedback has been previously used as a tool to manipulate efficacious beliefs (Hu et al. 2007; Motl et al. 2006; McAuley, Talbot and Martinez 1999), which is thus supported by the studies in this thesis. Additionally, none of the previously mentioned performance deception studies measured self-efficacy (Corbett et al. 2012; Parry, Chinnasamy and Micklewright 2012; Stone et al. 2012; Micklewright et al. 2010), therefore these findings provide a novel investigation of the significance of this construct in self-paced endurance exercise. It is proposed that the deception of previous performance feedback is thus a viable method for manipulating efficacious beliefs during exercise.

Even though the manipulation of performance beliefs was capable of influencing self-efficacy perceptions during the PACER TT, accompanying effects on pacing strategy or performance were not demonstrated. Despite the differences in efficacy between groups, performance improvements and changes in power output and speed in PACER were similar. This refutes previous research endorsing the strength of the positive relationship between self-efficacy and performance (McKay et al. 2012; Kalasountas, Reed and Fitzpatrick 2007; Ness and Patton 1979), but supports the findings presented in Chapter 3 that self-efficacy is not one of the most strongly associated variables with power output in cycling TTs. These findings also contrast the evidence of the relationships that have previously been found between self-efficacy and other perceptual constructs, as previously stated (Welch, Hulley and Beauchamp 2010; Hutchinson et al. 2008; Bandura 1997; McAuley and Courneya 1992). The absence of inversed patterns of self-efficacy and RPE in the PACER TT for example, contrasts the support for a strong negative relationship between these two constructs (Hutchinson et al. 2008; Hall, Ekkekakis and Petruzzello 2005; Pender et al. 2002). This relationship could have been influenced by the intensity of the exercise, demonstrated by a greater work-rate elicited in PACER than FBL and SUB, which is proposed to weaken the relationship the higher it is (Hutchinson et al. 2008; Hall, Ekkekakis and Petruzzello 2005). More likely though is that the feedback intervention, and its manipulation of efficacious perceptions as previously discussed, affected this relationship.

6.3.4 Summary

In summary, whilst the magnitude of the pacer did not influence overall pace or performance, it did effect perceptual experiences during the TT. Performing against a pacer which is faster than a previously accomplished performance induces more negative affective valence and higher perceptions of exertion, whereas a pacer that depicts a true prior effort does not exert this effect. Alternatively, the belief that the pacer is slower than it actually is, and is consequently a more attainable competitor, prevents a reduction in self-efficacy which is experienced when these beliefs are accurate. These perceptual variations however did not correspond with pacing strategy or performance as no between-group differences were found.

Consequently, it can be concluded that neither beliefs nor the magnitude of the avatar effected pace or performance and the changes in perceptual constructs did not have a significant direct influence on overall performance. Instead, the motivational benefits of the performance feedback and visual avatar, producing social facilitative effects and an increased willingness to invest effort, most likely enhanced performance regardless of what the pacer was or what the participants perceived it to be.

6.3.1 Residual Effects

The second focus of the studies within this thesis pertains to the exploration of residual effects of feedback provision on perceptual responses and performance variables during cycling TTs. Deception studies have typically addressed two main aims: to explore the mechanisms of pacing behaviour, and/or to investigate whether this method can be used to improve athletic performance. However, whilst several studies have demonstrated that certain deceptive exposures can elicit performance improvements or alterations to pacing strategies (Corbett et al. 2012; Parry, Chinnasamy and Micklewright 2012; Stone et al. 2012; Thomas and Renfree 2010; Morton 2009), none of these authors have examined whether these effects are also manifest in a subsequent exercise bout. The studies within this thesis were thus novel in their investigation of the residual effects of a previous performance deception. The importance of prior experience appraisals in the context of mastery, tolerance, effort willingness, pacing behaviour and beliefs of maximal capabilities are widely accepted (Marcora 2008; St Clair Gibson et al. 2006; Bandura 1997; Ulmer 1996) and deception is employed to manipulate beliefs and expectations to assess behaviour responses (Micklewright et al. 2010). Interestingly though, a lack of research has used the deception of previous performance feedback to explore the ability of manipulated beliefs pertaining to feelings of mastery and capabilities in future behaviour and decision making processes during endurance performance. Micklewright and colleagues (2010) acknowledged the potential significance of this interaction between previous experience and feedback in self-paced exercise, demonstrating that the exposure to false feedback influenced subsequent pacing strategy but not overall performance. Another study

explored the residual effects of a deception but by using a distance feedback manipulation and analysing pre to post changes, finding that deception did alter overall performance in the subsequent TT (Paterson and Marino 2004).

Practically, the application of deceptive methods in competitive sports performance more clearly lies in the subsequent effects of a deceptive training intervention, as deceiving athletes during a competitive performance generates difficulties in logistics and detectability and lacks pragmatism. In many cases, athletes will not have access to the same feedback that they have during training, and environmental stimuli could make the deception more easily detectable (e.g. time or distance markers, other competitors). Previous research designs that have only explored the acute responses to various feedback exposures may therefore lack contribution to our global understanding of the potential to implement these techniques into practice with athletes. The inclusion of a subsequent TT in the studies of this thesis and the findings of no significant residual effects on performance in the control or the deception groups, consequently attests that a single exposure to this type of feedback provision may not be a viable method for improving athletic performance with trained athletes. The value of such studies may therefore lie in a mechanistic context; exploring how and why decisions to alter work-rate are made.

One mechanism that has been commonly explored in previous deception studies has been that of perceived exertion (Eston et al. 2012; Parry, Chinnasamy and Micklewright 2012; Baden et al. 2005; Hampson et al. 2001). Many designs have aimed to reduce perceptions of exertion so that a greater work-rate can be sustained for a longer period of time and, ultimately, to result in an improved performance. These studies have supported the key role of RPE in exercise tolerance, both in time to exhaustion protocols and during self-regulated exercise. The Psychobiological Model proposes that task disengagement occurs when an individual either reaches the maximum effort they are willing to exert for the given task, or they reach the maximum amount of effort they believe is possible (Marcora 2008). Under this proposition, a shift in the trajectory of the RPE response, and therefore alteration to the RPE value associated with a given unit of work-rate, can

change this point of disengagement and consequently influence overall performance. The findings in this thesis demonstrate that feedback provision is able to alter this relationship between RPE and performance and provide support for this model (Marcora 2008) and previous research (Parry, Chinnasamy and Micklewright 2012; Stone et al. 2012; Micklewright et al. 2010). The CON₁₀₂, DEC and DEC_{kno} groups all experienced higher RPE values with associated increases in power output and speed in the PACER trial, but no residual effects in either variable were found. The CON_{FBL} group, however, similarly increased work-rate in PACER but in the absence of an increase in RPE. Furthermore, RPE was then higher in SUB than in FBL which indicates that there was also a residual response; the only one found across all groups. The universal improvement in PACER performance across groups supports that the motivational aid of the avatar might have increased their willingness to invest effort during the TT (Marcora 2008; Robergs et al. 1998). The removal of this aid in the SUB TT, however, may have had a more profoundly negative impact on exertional perceptions in the CON_{FBL} group as they did not have to tolerate higher perceptions in the PACER TT. Thus, in comparison, the SUB TT was perceived to be more exertional following a facilitative environment in the previous TT.

This finding is interesting considering that the experience of overcoming significant barriers in aversive situations is expected to improve tolerance and influence future behaviour (Weinberg and Gould 2007), but this was not evidenced in the SUB trial of any group. The deception groups in particular are likely to have faced tougher psychological barriers during PACER due to the negative mismatch in their perceptions of what they believed they were capable of achieving and the perceived difficulty to achieve their goals (Evans, Hoar and Gebotys 2014). This aversive situation however, whilst inflicting acute negative affective states, did not influence future behaviour. This is demonstrated by the absence of residual pacing and performance effects in both groups and also by the comparability to the control groups who did not experience this mismatch. Moreover, the group that could be considered to have had the least exposure to these barriers and to competitive suffering, the CON_{FBL} group, displayed a negative residual effect of

higher RPE in SUB (Bueno, Weinberg and Fernández-Castro 2008). Trained athletes typically have strong motivation, frequently fall short of goals, and display traits of stoicism and mental toughness in the face of challenges and negative perceptual feelings (Hutchinson et al. 2008; Williams, Donovan and Dodge 2000). It is thought that they learn to relish the mental and physical suffering that comes with exertional efforts in their chosen sport and develop adaptive coping strategies (Evans et al. 2014; Atkinson 2008). Thus these athletes may be less receptive to an intervention which creates a competitive suffering environment, preventing a larger and perhaps significant change in performance from FBL to SUB. Prior deception studies using trained athletes also support this proposition by showing the acute facilitative effects of negative performance appraisals and experience of higher psychological barriers (Parry, Chinnasamy and Micklewright 2012; Stone et al. 2012; Thomas and Renfree 2010). Furthermore, the increased perceptions of self-efficacy from PACER to SUB in all but the CON_{FBL} group, also indicates the benefits of the exposure to challenging feedback.

The CON_{FBL} were the only group in the PACER trial not to experience the most negative affect, highest RPE and lowest self-efficacy out of the three TTs. Additionally, they exhibited the most positive meaningful residual effect in performance, improving time by 0.9% in SUB compared to FBL. On the other hand, CON₁₀₂ were the only group to exhibit a negative residual response, performing SUB in a 0.6% slower time than FBL. With a calculated test-retest CV from the data obtained from baseline trials within this thesis, a performance change greater than 0.6% is indicated to be a worthwhile change, which is also supportive of previous data (Stone et al. 2011; Paton and Hopkins 2006). Hence, the improvement and deterioration in overall performance in the CON_{FBL} and CON₁₀₂ groups, respectively, could be interpreted as practically meaningful. Further research is warranted with larger and varying populations to clarify the potential practical implications of this type of feedback provision with athletes during training.

In the deception groups, 71% of participants elicited a faster performance in PACER than FBL but the nature of the deception implied that participants were unaware that this was potentially a mastery experience. In fact, only 50% of participants

actually perceived that they had performed faster than their baseline as a result of beating the avatar to the finish line. Hence, the disclosure of the true aims of the study to the participants prior to a subsequent performance was examined in Chapter 5 in order to create the perception of a mastery experience and observe the consequential effects of these perceptions. In addition, the knowledge was aimed to alter the athletes' perceptions of what their true maximal effort was, in accordance with the Psychobiological Model and as formerly discussed in relation to the CON_{FBL} group (Marcora 2008). If, albeit unknowingly, they were able to perform faster than their FBL and achieve a mastery performance, they would only acknowledge this augmentation in their own maximum potential if the deception was revealed and beliefs were restored. As cognitive theories and supporting experimental studies state that mastery experiences and high perceived efficacy increase exercise tolerance and persistence through motivational processes (Hutchinson et al. 2008; Bandura 1997; 1986), the reveal was expected to influence future behaviour and/or cognitive processes. The disclosure of this information, however, did not influence subsequent performance or perceptions as may have been expected. A potential explanation may lie in the between-subject differences in a) the individual performance outcomes in PACER in relation to the avatar, and b) each participant's personal appraisal of their performance. In the DEC_{kno} group, three out of the eight participants (38%) beat the pacer and therefore perceived that they had performed at a level greater than that of their supposed maximum before they had even received knowledge of the deception. The other five participants were informed that they had actually lost against a 102% pacer but this may not have implied that they interpreted this to be indicative of a mastery performance or that they had surpassed their prior efforts as they were not also informed of how their PACER performance compared to their FBL. These subjective variations could have therefore convoluted the effects of this knowledge and limit the understanding of whether this intervention is viable in facilitating perceptions of mastery. Future investigations may wish to more directly isolate the manipulations of performance mastery and control for the subjective appraisals of true maximum efforts, perhaps by also including supporting qualitative analysis.

6.3.2 Summary

In summary, no statistical residual effects on performance outcomes were found as a result of the provision of visual previous performance feedback. The deception of this feedback did not alter the subsequent performance outcomes, indicating that these deceptive methods do not have an enduring effect in 16.1 km self-paced cycling TTs. Similarly, no residual perceptual effects were found other than for RPE in CON_{FBL}, which increased following the provision of accurate baseline performance feedback. The disclosure of the true nature of the deceptive TT, correcting false performance beliefs prior to the subsequent exercise bout, did not influence any variable when compared to a group without knowledge of the deception exposure. It should be noted, however, that whilst the overall changes in completion time did not reach significance, the meaningfulness to TT performance should not be ignored. Receiving accurate feedback of an attainable goal resulted in a faster subsequent time whereas the provision of accurate feedback pertaining to a more difficult challenge resulted in a slower subsequent time.

6.4 FUTURE RESEARCH DIRECTIONS

A number of potential research directions arising from the findings within the studies of this thesis are subsequently proposed. Firstly, and as initially highlighted in Chapter 1, the experimental measurement of perceptual processes in prior pacing and deception research has been thus far limited. Affect was demonstrated to be strongly associated with power output in Chapter 3 but this relationship appears to differ when external feedback provisions are employed, as seen in Chapters 4 and 5. The influence of task dependency is also likely to be significant, as previously shown in exercise adherence contexts (Ekkekakis, Hargreaves and Parfitt 2013) and as demonstrated in Chapter 3 by a distance-dependant association. This is also evident in the inconsistencies identified with other recent studies exploring the prevalence of the affect-performance relationship in self-paced endurance exercise (Taylor and Smith 2014; Renfree et al. 2012). The construct of self-efficacy has also rarely been considered in the role of exercise regulation during endurance exercise, particularly within deception research. The studies within this thesis

demonstrate that deception can be used as a tool to manipulate efficacious beliefs, but the efficacy-performance relationship in cycling TTs appears weaker than previously found in other exercise modes and environments (McKay et al. 2012; Kalasountas, Reed and Fitzpatrick 2007; Ness and Patton 1979). It may be that self-efficacy contributes to self-regulatory processes in an indirect manner but the underlying mechanisms require further consolidation. Consequently, it is recommended that a concurrent measurement of a multitude of perceptual responses is necessary to further enhance the understanding of the mechanistic processes of self-regulation and feedback manipulations during exercise.

From reviewing the body of literature on deceptive methods, it was concluded that studies which imposed negative performance beliefs were the most consistent in eliciting beneficial effects to the exercise outcome (Stone et al. 2012; Thomas and Renfree 2010; Morton 2009). Whilst not hindering performance, the negative beliefs experienced in the studies within this thesis failed to demonstrate these facilitative outcomes when compared to control conditions. Furthermore, the absence of residual effects could suggest that only acute effects would have been observed in these prior studies too (Stone et al. 2012; Thomas and Renfree 2010; Morton 2009). Cognitive theories contrastingly support that mastery experiences and strong efficacious beliefs enhance performance, therefore Chapter 5 attempted to correct these negative beliefs and turn them into positive performance-enhancing beliefs in the DEC_{kno} group but residual performance and perceptual effects were still not evidenced. It may be thus warranted that deceptive interventions which create performance-enhancing beliefs, for example a pacer set slower than baseline, require further exploration.

If the success or failure of a task is believed to have a significant influence on future behaviour and perceptions (Brunstein and Gollwitzer 1996) through the creation or prevention of mastery experiences (Bandura 1986), then the outcome of the performance result should be considered in the research design itself. In the studies in the thesis, it was calculated that 22% of participants in the CON₁₀₂ group beat the avatar's performance, compared to 50% in the DEC groups and 70% in CON_{FBL}. Whilst the aims of this research were to investigate the overall improvements in

performance, namely the absolute differences between each trial, the varying outcome results may have influenced the athletes' behaviour and perceptions in the subsequent trial (Brunstein and Gollwitzer 1996). This is supported by the observation of the biggest performance improvement in the group with the highest success rate against the pacer, and a performance decrement in the group with the least success. This also resonates with a prior discussion of psychological barriers and the ability to overcome these challenges (Weinberg and Gould 2007). As the highest proportion of participants in the CON_{FBL} group beat the pacer, they were likely to have experienced feelings of goal achievement and competency in the face of aversion (Tenenbaum et al. 2005).

The strength and achievement of self-defining goals are crucial to the functional relationship between a failure situation and subsequent behaviour (Brunstein 2000), therefore it may also be important that future research consider the measurement of these goal-directed efforts. Prior to each trial within this series of studies, cyclists were reminded to perform the TT in the fastest time possible which relates to an externally-driven task-specific goal. An additional assumption was that the cyclists would also strive to beat the avatar in the PACER trial due to a high degree of intrinsic motivation (Baron et al. 2011). Individuals with self-defining goals, to strive towards a desired long term identity, may be more inclined to pursue their goals and adopt coping behaviours in the face of failure by increasing their goal-directed efforts to remedy a prior drawback (Brunstein 2000). The laboratory-based environment and likely dominance of more task-specific goals may have diminished the cyclists' desire to stimulate a remedial performance in the subsequent TT, following a failure in the pacer TT (Szalma et al. 2006). This is supported by the weakest SUB TT performance from the CON₁₀₂ where 78% of participants lost against the pacer and experienced failure. Further evidence for the need to more thoroughly explore the role of goals within the trials stems from goal theories, namely self-completion theory (Wicklund and Gollwitzer 1982). If goal discrepancies occur, engagement in self-regulatory processes and compensatory efforts can act to minimise this discrepancy (Matschke, Fehr and Sassenberg 2012). This supports the previous argument that individuals may strive to compensate for

a lack of goal attainment in a previous task but is again determined by identity-relevance and goal-relevance, which these current studies are unable to identify.

Experimental designs that allow us to clearly differentiate between acute performance gains arising from a deception intervention and those stemming from the presence of a competitor should be considered, following on from which, the residual effects can be better explored. A limitation of the studies within this thesis is the inability to determine whether residual effects of a previous performance deception do exist, as the acute performance improvements in PACER were not deemed to be a result of deception. Another factor to consider is that a single-trial deceptive intervention may not have been substantial enough to elicit a significant residual response in performance. Instead, exposure to repeat failure performance outcomes may be needed to intensify task-related effort and tolerance, and a desire to fight back to re-establish goals (Brunstein and Gollwitzer 1996). Alternatively, multiple failure experiences may also cause helplessness and a pessimistic disposition (Szalma et al. 2006; Brunstein and Gollwitzer 1996). Micklewright et al. (2010) used a two-time repeated exposure to deceptive feedback and found increases in power output and speed during the initial 5 km in the deception group but this could not be sustained. Participants perceived that they were performing better than they actually were which instead supports that multiple exposures to performance-enhancing beliefs and mastery experiences may be better able to facilitate subsequent performances. It is thus recommended that future research explores the effects of multiple exposures to deception, determining whether repeated failures and/or repeated mastery experiences influence behaviour and perceptual responses in subsequent performances.

The participants used across the studies in this thesis were trained cyclists with experience in the given task. This was pertinent to the exploration of pacing strategy modifications, but the findings may not be generalised to less well trained populations. It is suggested that individuals performing a novel task may be more susceptible to manipulations of self-efficacy (Hutchinson et al. 2008), hence it could be predicted that untrained populations would be less likely to detect deceptive discrepancies in feedback and the successfulness of interventions may be

accentuated. Contrastingly, two studies comparing the effects of blinded exercise duration feedback between well-trained and untrained cyclists demonstrated that trained athletes were responsive to the deception whilst the untrained population did not exhibit differences in performance or physiological markers (Williams, Bailey and Mauger 2012; Mauger, Jones and Williams 2009). Typically, the cognitive theories discussed within this thesis, e.g. self-efficacy and mastery experiences, have been tested in exercise settings lacking external validity (Hutchinson et al. 2008) and/or with untrained populations (Hutchinson et al. 2008; Welch, Hulley and Beauchamp 2010; Marquez et al. 2002). The refutation of these theories within this thesis' studies, which used externally valid cycling TT protocols and trained cyclists, again highlights the potentially confounding factors of training status, experience and exercise mode in the application of these exercise psychology theories to the self-regulation of competitive sports performance. Consequently, it is hypothesised that the effects of deception may vary between populations and exercise demands, and requires further investigation if it is wished to be applied in other contexts, such as exercise and health environments. Whilst many pacing studies are conducted in laboratory settings, commonly using TT protocols to allow during-trial adjustments to pace that would naturally occur in outdoor performances, a number of inherent limitations remain associated with the validity of this approach. Variations in gradient, drag, and weather conditions were not replicated in the environment used throughout the testing procedures therefore caution should be taken in the interpretation of raw performance values.

The importance of task dependency has been identified in the discussion of a number of mechanisms in comparison to previous literature. It has been shown that only the speed and not the accuracy of decision-making performance is affected by exercise intensity (Fontana, Mazzardo and Mokgothu 2009). Fontana and colleagues (2009) found that experienced soccer players were able to maintain similar decision-making accuracy across a range of exercise intensities. This could suggest the effect of deceptive manipulations on pacing behaviour observed in 16.1 km TTs (Chapters 4 and 5) may be similar to what would be expected in lower intensity 40 km TTs. Results from Chapter 3, however, demonstrated that the

affect-pacing strategy association differs in strength between 16.1 km and 40 km TTs. If affect is to be recognised as a key regulatory variable of exercise behaviour and a determinant of pacing decisions, then the former presumption may not be substantiated in endurance exercise.

Task dependency is supported by the differences in results between these studies and that of Stone et al.'s (2012) which employed a similar deceptive intervention but found contrasting performance outcomes. Four km TTs are a much shorter event (~6 min) than both 16.1 km (~27 min) and 40 km TTs (~72 min) and performed at a higher intensity and with greater physiological stress (Bentley, Cox and Green 2008; Hettinga et al. 2006). A deception in the first 1.66 km of a triathlon run segment, also performed at a much higher intensity than 16.1 km or 40 km cycling TTs, demonstrated discrepancies in the affect-speed relationship (Taylor and Smith 2014). Overall, this suggests that performance and perceptual responses to deception may differ between types of exercise and consequently, caution is warranted in the generalisability of findings across a range of exercise distances and intensities.

6.5 CONCLUSION

The main conclusions of this thesis relate to the influence and mechanistic contribution of perceptual constructs to regulatory processes during self-paced cycling TTs. The findings from the three experimental studies support the roles of affective valence, perceived exertion and efficacious appraisals during this mode of endurance exercise. Chapter 3 concluded that affect was one of the most strongly associated variables with power output during cycling TTs and this relationship was stronger in 16.1 km than 40 km TTs, supporting the importance of this construct in pacing behaviour. Chapters 4 and 5 both demonstrated that the deception of previous performance feedback, provided via the manipulation of a visual avatar's pacing profile, provides no additional acute benefit to TT performance compared to the provision of accurate visual feedback. It was identified that neither the magnitude of the pacer's performance nor the beliefs pertaining to the pacer were influential to performance outcomes. Alternatively, the presence of the visual pacer

is suggested to have provided facilitative motivational effects which allowed the trained cyclists to produce a greater effort than what they previously considered maximal.

The perceptual experiences during the feedback exposure, however, were found to vary between groups, indicated by differences in affect, RPE and self-efficacy. It was concluded that the magnitude of the pacer, and therefore the extent to how challenging the feedback was, resulted in differential affective and exertional perceptions. A more challenging environment, created using a 102% pacer, prompted more negative affect and higher RPE in the trial in which this feedback was presented. On the other hand, a pacer representing an athlete's true baseline performance did not elicit any changes to these constructs. Belief effects were therefore deemed to be uninfluential to affect and RPE responses. Contrastingly, the beliefs relating to the pacer were attributed to the between-group differences in self-efficacy, as false beliefs imposed in the deception groups were able to prevent a larger reduction in self-efficacy, as seen in the accurately informed 102% group. In summary, it is supported that during cycling TTs the pacer's magnitude but not beliefs are crucial to affective and exertional perceptions, and beliefs but not the magnitude influence self-efficacy appraisals.

Further synthesis of the findings of this thesis demonstrated that no residual performance effects were found, following either an accurate feedback intervention or a deceptive exposure. This demonstrates that the facilitative effects of a single exposure to visual previous performance feedback and the modification to the pacing schema are acute effects only and are not manifested in a subsequent exercise bout. Practically, this implies that this type of feedback provision may not be a suitable strategy to use with athletes in training if the aim is to enhance performance in a successive competition. The disclosure of the true nature of the deceptive intervention similarly did not influence athlete's performance or perceptual responses in the subsequent trial. This suggests that the correction of negative performance beliefs was insignificant to future behaviour and perceptual appraisals.

The roles of perceptual constructs in the regulation of exercise have been demonstrated to be influenced by feedback interventions during self-paced cycling exercise. The accompanying performance outcomes, however, are not emulative of these perceptual responses and were comparatively influenced across all feedback conditions. The findings contribute to our knowledge of the relationships between psychological processes and pacing behaviour and support the importance of continued research in this area to develop the mechanistic understanding of exercise regulation during endurance performance.

References

- Abbiss, C.R., and Laursen, P.B. (2008) Describing and understanding pacing strategies during athletic competition. *Sports Medicine*, 38(3), 239-52.
- Achten, J., and Jeukendrup, A.E. (2003) Heart rate monitoring: applications and limitations. *Sports Medicine*, 33(7), 517-38.
- Albertus, Y., Tucker, R., St Clair Gibson, A., Lambert, E.V., Hampson, D.B., and Noakes, T.D. (2005) Effect of distance feedback on pacing strategy and perceived exertion during cycling. *Medicine and Science in Sports and Exercise*, 37(3), 461-8.
- Andreacci, J.L., LeMura, L.M., Cohen, S.L., Urbansky, E.A., Chelland, S.A., and Von Duvillard, S.P. (2002) The effects of frequency of encouragement on performance during maximal exercise testing. *Journal of Sports Sciences*, 20(4), 345-52.
- Ansley, L., Robson, P.J., St Clair Gibson, A., and Noakes, T.D. (2004) Anticipatory pacing strategies during supramaximal exercise lasting longer than 30s. *Medicine and Science in Sports and Exercise*, 36(2), 309-14.
- Atkinson, M. (2008) Triathlon, suffering and exciting significance. *Leisure Studies*, 27(2), 165-80.
- Atkinson, G., and Nevill, A.M. (2001) Selected issues in the design and analysis of sport performance research. *Journal of Sports Sciences*, 19, 811-27.
- Atkinson, G., Peacock, O., St Clair Gibson, A., and Tucker, R. (2007) Distribution of power output during cycling: impact and mechanisms. *Sports Medicine*, 37(8), 647-67.
- Baden, D.A., McLean, T.L., Tucker, R., Noakes, T.D., and St Clair Gibson, A. (2005) Effect of anticipation during unknown or unexpected exercise duration on rating of perceived exertion, affect, and physiological function. *British Journal of Sports Medicine*, 39(10), 742-6.
- Bandura, A. (1986) *Social Foundations of Thought and Action: A Social Cognitive Theory*. Englewood Cliffs, NJ: Prentice Hall.
- Bandura, A. (1997) *Self-Efficacy: The Exercise of Control*. New York: Freeman.
- Bandura, A. (2005) Guide for creating self-efficacy scales. In: F. Pajares and T. Urdan (Eds.) *Self-efficacy Beliefs of Adolescents* (pp 307-37). Greenwich, CT: Information Age Publishing.
- Baron, B., Moullan, F., Deruelle, F., and Noakes, T.D. (2011) The role of emotions on pacing strategies and performance in middle and long duration sport events. *British Journal of Sports Medicine*, 45(6), 511-7.
- Bartholomew, J.B. (2000) Stress reactivity after maximal exercise: the effect of manipulated performance feedback in endurance athletes. *Journal of Sports Sciences*, 18(11), 893-9.

- Barwood, M.J., Weston, N.J.V., Thelwell, R., and Page, J. (2009) A motivational music and video intervention improves high-intensity exercise performance. *Journal of Sports Science and Medicine*, 8(1), 435–42.
- Beedie, C.J., and Foad, A.J. (2009) The placebo effect in sports performance: a brief review. *Sports Medicine*, 39(4), 313–29.
- Beedie, C.J., Lane, A.M., and Wilson, M.G. (2012) A possible role for emotion and emotion regulation in physiological responses to false performance feedback in 10 mile laboratory cycling. *Applied Psychophysiology and Biofeedback*, 30, 1–9.
- Bentley, D.J., Cox, G.R., Green, D., and Laursen, P.B. (2008) Maximising performance in triathlon: Applied physiological and nutritional aspects of elite and non-elite competitions. *Journal of Science and Medicine in Sport*, 11, 407–16.
- Billaut, F., Bishop, D.J., Schaerz, S., and Noakes, T.D. (2011) Influence of knowledge of sprint number on pacing during repeated-sprint exercise. *Medicine and Science in Sports and Exercise*, 43(4), 665–72.
- Bishop, D., Jenkins, D.G., and Howard, A. (1998) The critical power function is dependent on the duration of the predictive exercise tests chosen. *International Journal of Sports Medicine*, 19(2), 125–9.
- Blanchfield, A.W., Hardy, J., De Morree, H.M., Staiano, W., and Marcora, S.M. (2014) Talking yourself out of exhaustion: the effects of self-talk on endurance performance. *Medicine and Science in Sports and Exercise*, 46, 998–1007.
- Borg, G. (1970) Perceived exertion as an indicator of somatic stress. *Scandinavian Journal of Rehabilitation Medicine*, 2(2), 92–8.
- Borg, G. (1982) Psychophysical bases of perceived exertion. *Medicine and Science in Sport and Exercise*, 14(5), 377–81.
- Boullosa, D.A., and Nakamura, F.Y. (2013) The evolutionary significance of fatigue. *Frontiers in Physiology*, 4(309), 1–2.
- British Psychological Society (2010) Code of Human Research Ethics [online]. Available from URL: http://www.bps.org.uk/sites/default/files/documents/code_of_human_research_ethics.pdf [Accessed 2013 Feb 22].
- Brunstein, J.C. (2000) Motivation and performance following failure: The effortful pursuit of self-defining goals. *Applied Psychology*, 49(3), 340–56.
- Brunstein, J.C., and Gollwitzer, P.M. (1996) Effects of failure on subsequent performance: the importance of self-defining goals, 70(2), 395–407.
- Bueno, J., Weinberg, R.S., Fernández-Castro, J., and Capdevila, L. (2008). Emotional and motivational mechanisms mediating the influence of goal setting on endurance athletes' performance. *Psychology of Sport and Exercise*, 9(6), 786–99.

- Clark, S.E., and Ste-Marie, D.M. (2007) Investigating the impact of self-as-a-model interventions on children's self-regulation of learning and swimming performance. *Journal of Sports Sciences*, 25, 577–86.
- Corbett, J., Barwood, M. J., Ouzounoglou, A., Thelwell, R., and Dicks, M. (2012) Influence of competition on performance and pacing during cycling exercise. *Medicine and Science in Sports and Exercise*, 44(3), 509–15.
- Corbett, J., Barwood, M.J., and Parkhouse, K. (2009) Effect of task familiarisation on distribution of energy during a 2000 m cycling time trial. *British Journal of Sports Medicine*, 43(10), 770–4.
- Craig, N.P., and Norton, K.I. (2001) Characteristics of track cycling. *Sports Medicine*, 31, 457–68.
- Crewe, H., Tucker, R., and Noakes, T.D. (2008) The rate of increase in rating of perceived exertion predicts the duration of exercise to fatigue at a fixed power output in different environmental conditions. *European Journal of Applied Physiology*, 103(5), 569–77.
- Davidson, R.J. (2004) What does the prefrontal cortex do in affect? Perspectives on frontal EEG asymmetry research. *Biological Psychology*, 67(1–2), 219–23.
- Davison, R.C.R., Corbett J., and Ansley, L. (2009) Influence of temperature and protocol on the calibration of the CompuTrainer electromagnetically-braked cycling ergometer. *International Journal of Sports Medicine*, 10, 66–76.
- De Pauw, K., Roelands, B., Cheung, S.S., de Geus, B., Rietjens, G., and Meeusen, R. (2013) Guidelines to classify subject groups in sport-science research. *International Journal of Sports Physiology and Performance*, 8(2), 111-22.
- Department of Health (2008) World Medical Association Declaration of Helsinki: Ethical Principles for Medical Research Involving Human Subjects [online]. Available from URL: <http://www.wma.net/en/30publications/10policies/b3/> [Accessed 2013 Feb 22].
- Drust, B., Atkinson, G., and Reilly, T. (2007) Future perspectives in the evaluation of the physiological demands of soccer. *Sports Medicine*, 37(9), 783-805.
- Drust, B., Waterhouse, J., Atkinson, G., Edwards, B., and Reilly, T. (2005) Circadian Rhythms in Sports Performance- an Update. *Chronobiology International*, 22(1), 21–44.
- Dwyer, D. (2004) Continuous ramp test on a bicycle ergometer. *Journal of Exercise Physiology*, 2(4), 1–9.
- Edwards, A.M., and Polman, R.C.J. (2013) Pacing and awareness: Brain regulation of physical activity. *Sports Medicine*, 43(11), 1057–64.
- Ekkekakis, P. (2003) Pleasure and displeasure from the body: Perspectives from exercise. *Cognition and Emotion*, 17(2), 213–39.

- Ekkekakis, P., Hall, E.E., and Petruzzello, S.J. (2005) Variation and homogeneity in affective responses to physical activity of varying intensities: An alternative perspective on dose-response based on evolutionary considerations. *Journal of Sports Sciences*, 23, 477-500.
- Ekkekakis, P., Hargreaves, E.A., and Parfitt, G. (2013) Invited Guest Editorial: Envisioning the next fifty years of research on the exercise–affect relationship. *Psychology of Sport and Exercise*, 14(5), 751–8.
- Ekkekakis, P., Parfitt, G., and Petruzzello, S.J. (2011) The pleasure and displeasure people feel when they exercise at different intensities. Decennial update and progress towards a tripartite rationale for exercise intensity prescription. *Sports Medicine*, 41(8), 641–71.
- Eston, R.G., Faulkner, J., St Clair Gibson, A., Noakes, T.D., and Parfitt, G. (2007) The effect of antecedent fatiguing activity on the relationship between perceived exertion and physiological activity during a constant load exercise task. *Psychophysiology*, 44(5), 779–86.
- Eston, R., Stansfield, R., Westoby, P., and Parfitt, G. (2012) Effect of deception and expected exercise duration on psychological and physiological variables during treadmill running and cycling. *Psychophysiology*, 49(4), 462–9.
- Evans, M.B., Hoar, S.D., Gebotys, R.J., and Marchesin, C.A. (2014) Endurance athletes' coping function use during competitive suffering episodes. *European Journal of Sport Science*, 14(4), 368–75.
- Faulkner, J., and Eston, R.G. (2008) Perceived exertion research in the 21st century: Developments, reflections and questions for the future. *Journal of Exercise Science and Fitness*, 6(1), 1–14.
- Faulkner, J., Arnold, T., and Eston, R. (2011) Effect of accurate and inaccurate distance feedback on performance markers and pacing strategies during running. *Scandinavian Journal of Medicine and Science in Sports*, 21(6), 176–83.
- Flyger, N. (2008) Variability in competitive performance of elite track cyclists. *ISN Bulletin*, 1(2), 27–32.
- Fontana, F.E., Mazzardo, O., Mokgothu, C., Furtado, O., and Gallagher, J.D. (2009) Influence of exercise intensity on the decision-making performance of experienced and inexperienced soccer players. *Journal of Sport and Exercise Psychology*, 31(2), 135–51.
- Foss, Ø., and Hallén, J. (2005) Validity and stability of a computerized metabolic system with mixing chamber. *International Journal of Sports Medicine*, 26(7), 569–75.
- Foster, C., Hendrickson, K.J., Peyer, K., Reiner, B., de Koning, J.J., Lucia, A., and Wright, G. (2009) Pattern of developing the performance template. *British Journal of Sports Medicine*, 43(10), 765–9.

- Foster, C., Hoyos, J., Earnest, C., and Lucia, A. (2005) Regulation of energy expenditure during prolonged athletic competition. *Medicine and Science in Sports and Exercise*, 37(4), 670-5.
- Gandevia, S.C. (2001) Spinal and supraspinal factors in human muscle fatigue. *Physiological Reviews*, 81(4), 1725-89.
- Gaudreau, P., Blondin, J.P., and Lapierre, A.M. (2002) Athletes' coping during competition: Relationship of coping strategies with positive affect, negative affect, and performance-goal discrepancy. *Psychology of Sport and Exercise*, 3(2), 125-50.
- Gladden, L.B. (2008) A lactatic perspective on metabolism. *Medicine and Science in Sports and Exercise*, 40, 477-85.
- Hall, E.E., Ekkekakis, P., and Petruzzello, S.J. (2005) Is the relationship of RPE to psychological factors intensity-dependent? *Medicine and Science in Sports and Exercise*, 37(8), 1365-73.
- Halson, S.L., and Martin, D.T. (2013) Lying to win-placebos and sport science. *International Journal of Sports Physiology and Performance*, 8(6), 597-9.
- Hampson, D.B., St Clair Gibson, A., Lambert, M.I., Dugas, J.P., Lambert, E.V., and Noakes, T.D. (2004) Deception and perceived exertion during high-intensity running bouts. *Perceptual and Motor Skills*, 98, 1027-38.
- Hampson, D.B., St Clair Gibson, A., Lambert, M.I., and Noakes, T.D. (2001) The influence of sensory cues on the perception of exertion during exercise and central regulation of exercise performance. *Sports Medicine*, 31(13), 935-52.
- Hardy, C.J., and Rejeski, W.J. (1989) Not what, but how one feels: The measurement of affect during exercise. *Journal of Sport and Exercise Psychology*, 11(3), 304-17.
- Hettinga, F.J., de Koning, J.J., Broersen, F.T., Van Geffen, P., and Foster, C. (2006) Pacing strategy and the occurrence of fatigue in 4000-m cycling time trials. *Medicine and Science in Sports and Exercise*, 38(8), 1484-91.
- Hettinga, F.J., de Koning, J.J., Hulleman, M., and Foster, C. (2012). Relative importance of pacing strategy and mean power output in 1500-m self-paced cycling. *British Journal of Sports Medicine*, 46(1), 30-5.
- Hopkins, W.G., and Hewson, D.J. (2001) Variability of competitive performance of distance runners. *Medicine and Science in Sports and Exercise*, 33, 1588-92.
- Hu, L., Motl, R.W., McAuley, E., and Konopack, J.F. (2007) Effects of self-efficacy on physical activity enjoyment in college-aged women. *International Journal of Behavioral Medicine*, 14(2), 92-6.
- Hulleman, M., de Koning, J.J., Hettinga, F.J., and Foster, C. (2007) The effect of extrinsic motivation on cycle time trial performance. *Medicine and Science in Sports and Exercise*, 39(4), 709-15.

- Hutchinson, J.C., and Tenenbaum, G. (2006) Perceived effort- Can it be considered gestalt? *Psychology of Sport and Exercise*, 7(5), 463–76.
- Hutchinson, J.C., Sherman, T., Martinovic, N., and Tenenbaum, G. (2008) The effect of manipulated self-efficacy on perceived and sustained effort. *Journal of Applied Sport Psychology*, 20(4), 457–72.
- Hunter, S.K., Duchateau, J., and Enoka, R.M. (2004) Muscle fatigue and the mechanisms of task failure. *Exercise and Sport Sciences Reviews*, 32(2), 44-9.
- Jeukendrup, A.E., Hopkins, S., Aragón-Vargas, L.F., and Hulston, C. (2008) No effect of carbohydrate feeding on 16 km cycling time trial performance. *European Journal of Applied Physiology*, 104(5), 831–7.
- Jones, A.M. (2007) Middle- and long- distance running. In: E.M. Winter, A.M. Jones, R.C.R Davison, P.D. Bromley and T.H. Mercer (Eds.) *Sport and Exercise Physiology Testing Guidelines: Volume I - Sport Testing* (pp 147–54). London, UK: Routledge.
- Joseph, T., Johnson, B., Battista, R.A., Wright, G., Dodge, C., Porcari, J., de Koning, J., and Foster, C. (2008) Perception of fatigue during simulated competition. *Medicine and Science in Sports and Exercise*, 40(2), 381–6.
- Kalasountas, V., Reed, J., and Fitzpatrick, J. (2007) The effect of placebo-induced changes in expectancies on maximal force production in college students. *Journal of Applied Sport Psychology*, 19(1), 116–24.
- Kilpatrick, M., Kraemer, R., Bartholomew, J., Acevedo, E., and Jarreau, D. (2007) Affective responses to exercise are dependent on intensity rather than total work. *Medicine and Science in Sports and Exercise*, 39(8), 1417–23.
- Knicker, A.J., Renshaw, I., Oldham, A.R.H., and Cairns, S.P. (2011) Interactive processes link the multiple symptoms of fatigue in sport competition. *Sports Medicine*, 41(4), 307–28.
- de Koning, J.J., Foster, C., Bakkum, A., Kloppenburg, S., Thiel, C., Joseph, T., and Porcari, J. P. (2011) Regulation of pacing strategy during athletic competition. *PLoS ONE*, 6(1), e15863.
- Lambert, E.V., St Clair Gibson, A., and Noakes, T.D. (2005) Complex systems model of fatigue: Integrative homeostatic control of peripheral physiological systems during exercise in humans. *British Journal of Sports Medicine*, 39(1), 52–62.
- Lander, P.J., Butterly, R.J., and Edwards, A.M. (2009) Self-paced exercise is less physically challenging than enforced constant pace exercise of the same intensity: Influence of complex central metabolic control. *British Journal of Sports Medicine*, 43(10), 789–95.
- Lane, A.M., Wilson, M.G., Whyte, G.P., and Shave, R. (2011) Physiological correlates of emotion-regulation during prolonged cycling performance. *Applied Psychophysiology and Biofeedback*, 36(3), 181–4.

- Laurent, C.M., and Green, J.M. (2009) Multiple models can concurrently explain fatigue during human performance. *International Journal of Exercise Science*, 2(4), 280-93.
- Laursen, P.B., Shing, C.M., and Jenkins, D.G. (2003) Reproducibility of a laboratory-based 40-km cycle time-trial on a stationary wind-trainer in highly trained cyclists. *International Journal of Sports Medicine*, 24(7), 481–5.
- Lind, E., Ekkekakis, P., and Vazou, S. (2008) The affective impact of exercise intensity that slightly exceeds. *Journal of Health Psychology*, 13(4), 464-8.
- Marcora, S. (2008) Do we really need a central governor to explain brain regulation of exercise performance? *European Journal of Applied Physiology*, 104(5), 929–31.
- Marcora, S., and Staiano, W. (2010) The limit to exercise tolerance in humans: Mind over muscle? *European Journal of Applied Physiology*, 109(4), 763–70.
- Marino, F.E., Gard, M., and Drinkwater, E.J. (2011) The limits to exercise performance and the future of fatigue research. *British Journal of Sports Medicine*, 45(1), 65–7.
- Marquez, D.X., Jerome, G.J., McAuley, E., Snook, E.M., and Canaklisova, S. (2002) Self-efficacy manipulation and state anxiety responses to exercise in low active women. *Psychology and Health*, 17(6), 783–91.
- Matschke, C., Fehr, J., and Sassenberg, K. (2012) When does goal discrepancy induce compensatory effort? An application of self-completion theory to social issues. *Social and Personality Psychology Compass*, 7, 536–50.
- Mauger, A.R., Jones, A.M., and Williams, C.A. (2009) Influence of feedback and prior experience on pacing during a 4-km cycle time trial. *Medicine and Science in Sports and Exercise*, 41(2), 451–8.
- Mauger, A.R., Jones, A.M., and Williams, C.A. (2010) Influence of exercise variation on the retention of a pacing strategy. *European Journal of Applied Physiology*, 108(5), 1015–23.
- Mauger, A.R., Jones, A.M., and Williams, C.A. (2011) The effect of non-contingent and accurate performance feedback on pacing and time trial performance in 4-km track cycling. *British Journal of Sports Medicine*, 45(3), 225–9.
- McAuley, E., and Courneya, K.S. (1992) Self-efficacy relationships with affective and exertion responses to exercise. *Journal of Applied Social Psychology*, 22, 312-26.
- McAuley, E., Talbot, H.M., and Martinez, S. (1999) Manipulating self-efficacy in the exercise environment in women: Influences on affective responses. *Health Psychology*, 18(3), 288–94.
- McKay, B., Lewthwaite, R., and Wulf, G. (2012) Enhanced expectancies improve performance under pressure. *Frontiers in Psychology*, 3, 8.

- Mestre, D.R., and Dagonneau, V. (2011) Does virtual reality enhance exercise performance, enjoyment, and dissociation? An exploratory study on a stationary bike apparatus. *Presence*, 20(1), 1–14.
- Micklewright, D., Papadopoulou, E., Swart, J., and Noakes, T.D. (2010) Previous experience influences pacing during 20 km time trial cycling. *British Journal of Sports Medicine*, 44(13), 952–60.
- Midgley, A.W., McNaughton, L.R., Polman, R., and Marchant, D. (2007) Criteria for determination of maximal oxygen uptake. *Sports Medicine*, 37(12), 1019–28.
- Mollard, J.F. (1994) *Pre-Analytical Considerations in pH/Blood Gas Analysis*. Schaffhausen, Switzerland: AVL Medical Instruments AG.
- Morton, R.H. (2009) Deception by manipulating the clock calibration influences cycle ergometer endurance time in males. *Journal of Science and Medicine in Sport*, 12(2), 332–7.
- Motl, R.W., Konopack, J.F., Hu, L., and McAuley, E. (2006) Does self-efficacy influence leg muscle pain during cycling exercise? *Journal of Pain*, 7(5), 301–7.
- Ness, G.R., and Patton, R.W. (1979) The effect of beliefs on maximum weight-lifting performance. *Cognitive Therapy and Research*, 3(2), 205–11.
- Nikolopoulos, V., Arkinstall, M.J., and Hawley, J.A. (2001) Pacing strategy in simulated cycle time-trials is based on perceived rather than actual distance. *Journal of Science and Medicine in Sport*, 4(2), 212–9.
- Noakes, T.D. (2004) Linear relationship between the perception of effort and the duration of constant load exercise that remains. *Journal of Applied Physiology*, 96(4), 1571–2.
- Noakes, T.D. (2011) Time to move beyond a brainless exercise physiology: The evidence for complex regulation of human exercise performance. *Applied Physiology, Nutrition and Metabolism*, 36(1), 23–35.
- Noakes, T.D. (2012) Fatigue is a brain-derived emotion that regulates the exercise behavior to ensure the protection of whole body homeostasis. *Frontiers in Physiology*, 3(82), 1–13.
- Noakes, T.D. (2012b) The Central Governor Model in 2012: Eight new papers deepen our understanding of the regulation of human exercise performance. *British Journal of Sports Medicine*, 46(1), 1–3.
- Noakes, T.D., and St Clair Gibson, A. (2004) Logical limitations to the "catastrophe" models of fatigue during exercise in humans. *British Journal of Sports Medicine*, 38, 648–9.
- Noakes, T.D., St Clair Gibson, A., and Lambert, E.V. (2005) From catastrophe to complexity: A novel model of integrative central neural regulation of effort and fatigue during exercise in humans: Summary and conclusions. *British Journal of Sports Medicine*, 39(2), 120–4.

- Noreen, E.E., Yamamoto, K., and Clair, K. (2010). The reliability of a simulated uphill time trial using the Velotron electronic bicycle ergometer. *European Journal of Applied Physiology*, 110(3), 499–506.
- Palmer, G.S., Backx, K., and Hawley, J.A. (1998) Perceived rather than actual distance determines pacing strategy during simulated cycling time trials. *Medicine and Science in Sports and Exercise*, 30(5), 305.
- Parfitt, G., and Rose, E.A. (2000) The Effect of Prescribed and Preferred Intensity Exercise on Psychological Affect and the Influence of Baseline Measures of Affect. *Journal of Health Psychology*, 5(2), 231–40.
- Parry, D., Chinnasamy, C., and Micklewright, D. (2012) Optic flow influences perceived exertion during cycling. *Journal of Sport and Exercise Psychology*, 34(4), 444–56.
- Paterson, S., and Marino, F.E. (2004) Effect of deception of distance on prolonged cycling performance. *Perceptual Motor Skills*, 98, 1017–26.
- Paton, C.D., and Hopkins, W.G. (2006) Variation in performance of elite cyclists from race to race. *European Journal of Sport Science*, 6(1), 25–31.
- Pender, N.J., Bar-Or, O., Wilk, B., and Mitchell, S. (2002) Self-efficacy and perceived exertion of girls during exercise. *Nursing Research*, 51(2), 86–91.
- Pires, F.O., and Hammond, J. (2012) Manipulation effects of prior exercise intensity feedback by the Borg scale during open-loop cycling. *British Journal of Sports Medicine*, 46(1), 18–22.
- Pyne, D.B., Boston, T., Martin, D.T., and Logan, A. (2000) Evaluation of the Lactate Pro blood lactate analyser. *European Journal of Applied Physiology*, 82, 112–6.
- Ram, N. and McCullagh, P. (2003) Self-modeling: Influence on psychological responses and physical performance. *The Sport Psychologist*, 17, 220–41.
- Rauch, H.G.L., St Clair Gibson, A., Lambert, E.V., and Noakes, T.D. (2005) A signalling role for muscle glycogen in the regulation of pace during prolonged exercise. *British Journal of Sports Medicine*, 39(1), 34–8.
- Renfree, A., Martin, L., Micklewright, D. and St Clair Gibson, A. (2014) Application of decision-making theory to the regulation of muscular work rate during self-paced competitive endurance activity. *Sports Medicine*, 44(2), 147–58.
- Renfree, A., West, J., Corbett, M., Rhoden, C., and St Clair Gibson, A. (2012) Complex interplay between determinants of pacing and performance during 20-km cycle time trials. *International Journal of Sports Physiology and Performance*, 7(2), 121–9.
- Rietjens, G.J., Kuipers, H., Kester, A.D., and Keizer, H.A. (2001) Validation of a computerized metabolic measurement system (Oxycon-Pro) during low and high intensity exercise. *International Journal of Sports Medicine*, 22(4), 291–4.

- Robergs, R.A., Bereket, S., and Knight, M.A. (1998) Video-assisted cycling alters perception of effort and increases self-selected exercise intensity. *Perceptual and Motor Skills*, 86(3), 915-27.
- Rymal, A.M., Martini, R., and Ste-Marie, D.M. (2010) Self-regulatory processes employed during self-modelling: A qualitative analysis. *Sport Psychology*, 24, 1–15.
- Sanchez, X., Boschker, M.S.J., and Llewellyn, D.J. (2010) Pre-performance psychological states and performance in an elite climbing competition. *Scandinavian Journal of Medicine and Science in Sports*, 20(2), 356–63.
- Schabort, E.J., Hawley, J.A., Hopkins, W.G., and Blum, H. (1999) High reliability of performance of well-trained rowers on a rowing ergometer. *Journal of Sports Sciences*, 17, 627- 32.
- Smits, B.L.M., Pepping, G.J., and Hettinga, F.J. (2014) Pacing and decision making in sport and exercise: The roles of perception and action in the regulation of exercise intensity. *Sports Medicine*, 44(6), 763–75.
- Sparks, S.A., and Close, G.L. (2013). Validity of a portable urine refractometer: The effects of sample freezing. *Journal of Sports Sciences*, 31(7), 745-9.
- St Clair Gibson, A., and Noakes, T.D. (2004) Evidence for complex system integration and dynamic neural regulation of skeletal muscle recruitment during exercise in humans. *British Journal of Sports Medicine*, 38(6), 797–806.
- St Clair Gibson, A., Baden, D.A., Lambert, M.I., Lambert, E.V., Harley, Y. X., Hampson, D., Russell, V.A., and Noakes, T.D. (2003) The conscious perception of the sensation of fatigue. *Sports Medicine*, 33(3), 167–76.
- St Clair Gibson, A., Lambert, E.V., Rauch, L.H.G., Tucker, R., Baden, D.A., Foster, C., and Noakes, T.D. (2006) The role of information processing between the brain and peripheral physiological systems in pacing and perception of effort. *Sports Medicine*, 36(8), 705–22.
- St Clair Gibson, A., Schabort, E.J., and Noakes, T.D. (2001) Reduced neuromuscular activity and force generation during prolonged cycling. *American Journal of Physiology: Regulatory, Integrative and Comparative Physiology*, 281, 187-196.
- Ste-Marie, D.M., Vertes, K., Rymal, A.M., and Martini, R. (2011) Feedforward self-modeling enhances skill acquisition in children learning trampoline skills. *Frontiers in Psychology*, 2, 155.
- Stoate, I., Wulf, G., and Lewthwaite, R. (2012) Enhanced expectancies improve movement efficiency in runners. *Journal of Sports Sciences*, 30(8), 37–41.
- Stone, M. R., Thomas, K., Wilkinson, M., St Clair Gibson, A., and Thompson, K. G. (2011) Consistency of perceptual and metabolic responses to a laboratory-based simulated 4,000-m cycling time trial. *European Journal of Applied Physiology*, 111(8), 1807–13.

- Stone, M.R., Thomas, K., Wilkinson, M., Jones, A.M., St Clair Gibson, A., and Thompson, K.G. (2012) Effects of deception on exercise performance: Implications for determinants of fatigue in humans. *Medicine and Science in Sports and Exercise*, 44(3), 534–41.
- Swart, J., Lamberts, R.P., Lambert, M.I., St Clair Gibson, A., Lambert, E.V., Skowno, J., and Noakes, T.D. (2009) Exercising with reserve: Evidence that the central nervous system regulates prolonged exercise performance. *British Journal of Sports Medicine*, 43(10), 782–8.
- Swart, J., Lamberts, R.P., Lambert, M.I., Lambert, E.V., Woolrich, R.E., Johnston, S., and Noakes, T.D. (2009) Exercising with reserve: Exercise regulation by perceived exertion in relation to duration of exercise and knowledge of endpoint. *British Journal of Sports Medicine*, 43(10), 775–81.
- Swart, J., Lindsay, T.R., Lambert, M.I., Brown, J.C., and Noakes, T.D. (2012) Perceptual cues in the regulation of exercise performance- physical sensations of exercise and awareness of effort interact as separate cues. *British Journal of Sports Medicine*, 46(1), 42–8.
- Szalma, J.L., Hancock, P.A., Dember, W.N., and Warm, J.S. (2006) Training for vigilance: The effect of knowledge of results format and dispositional optimism and pessimism on performance and stress. *British Journal of Psychology*, 97(1), 115–35.
- Tate, A.K., Petruzello, S.J., and Lox, C.L. (1995) Examination of the relationship between self-efficacy and affect at varying levels of aerobic exercise intensity. *Journal of Applied Social Psychology*, 25, 1922-36.
- Taylor, D., and Smith, M.F. (2014) Effects of deceptive running speed on physiology, perceptual responses, and performance during sprint-distance triathlon. *Physiology and Behavior*, 133, 45–52.
- Tenenbaum, G., Hall, H.K., Calcagnini, N., and Lance, R. (2001) Coping with physical exertion and negative feedback under competitive and self-standard conditions, *Journal of Applied Social Psychology*, 31(8), 1582–626.
- Tenenbaum, G., Lidor, R., Lavyan, N., Morrow, K., Tonnel, S., and Gershgoren, A. (2005) Dispositional and task-specific social-cognitive determinants of physical effort perseverance. *The Journal of Psychology*, 139(2), 139–57.
- Thomas, G., and Renfree, A. (2010) The Effect of Secret Clock Manipulation on 10km Cycle Time. *International Journal of Arts and Sciences*, 3(9), 193–202.
- Thomas, K., Stone, M.R., Thompson, K.G., St Clair Gibson, A., and Ansley, L. (2012) Reproducibility of pacing strategy during simulated 20-km cycling time trials in well-trained cyclists. *European Journal of Applied Physiology*, 112(1), 223–9.
- Treasure, D.C., Monson, J., and Lox, C.L. (1996) Relationship between self-efficacy, wrestling performance and affect prior to a competition. *The Sport Psychologist*, 10, 73–83.

- Tucker, R. (2009) The anticipatory regulation of performance: The physiological basis for pacing strategies and the development of a perception-based model for exercise performance. *British Journal of Sports Medicine*, 43(6), 392–400.
- Tucker, R., and Noakes, T.D. (2009) The physiological regulation of pacing strategy during exercise: A critical review. *British Journal of Sports Medicine*, 43, 1–10.
- Turk, D.C. (2004) Understanding pain sufferers: The role of cognitive processes. *The Spine Journal*, 4, 1–7.
- Ulmer, H.V. (1996) Concept of an extracellular regulation of muscular metabolite rate during heavy exercise in humans by psychophysiological feedback. *Experientia*, 52, 416-20.
- Van Blerk, M., Coucke, W., Chatelain, B., Goossens, W., Jochmans, K., Meeus, P., and Libeer, J.C. (2007) External quality assessment in the measurement of haemoglobin by blood gas analysers in Belgium. *Scandinavian Journal of Clinical and Laboratory Investigation*, 67(7), 735-40.
- Vaughan, G., and Guerin, B. (1997) A neglected innovator in sports psychology: Norman Triplett and the early history of competitive performance. *The International Journal of the History of Sport*, 14(2), 82-99.
- Weinberg, R.S., and Gould, D. (2007) *Foundations of Sport and Exercise Psychology*. Champaign, IL: Human Kinetics.
- Weinberg, R.S., Gould, D., and Jackson, A. (1979) Expectations and performance: An empirical test of Bandura's self-efficacy theory. *Journal of Sport Psychology*, 1, 320–31.
- Weinberg, R.S., Gould, D., Yukelson, S., and Jackson, A. (1981) The effect of pre-existing and manipulated self-efficacy on a competitive muscular endurance task. *Journal of Sport Psychology*, 4, 345–54.
- Weinberg, R.S., Yukelson, S., and Jackson, A. (1980) Effect of public and private expectations on competitive performance. *Journal of Sport Psychology*, 2, 340–9.
- Weir, J.P., Beck, T.W., and Cramer, J.T. (2006) Is fatigue all in your head? A critical review of the central governor model. *British Journal of Sports Medicine*, 40, 573–86.
- Welch, A.S., Hulley, A., and Beauchamp, M. (2010) Affect and self-efficacy responses during moderate-intensity exercise among low-active women: The effect of cognitive appraisal. *Journal of Sport and Exercise Psychology*, 32(2), 154–75.
- Wicklund, R.A., and Gollwitzer, P.M. (1982) *Symbolic Self-Completion*. Hillsdale, NJ: Erlbaum.
- Williams, C.A, Bailey, S.D., and Mauger, A.R. (2012) External exercise information provides no immediate additional performance benefit to untrained individuals in time trial cycling. *British Journal of Sports Medicine*, 46(1), 49–53.

- Williams, K.J., Donovan, J.J., and Dodge, T.L. (2000) Self-regulation of performance: Goal establishment and goal revision processes in athletes. *Human Performance*, 13(2), 159-80.
- Williams, E.L., Jones, H.S., Sparks, S.A., Marchant, D.C., Midgley, A.W., and McNaughton, L.R. (2014) Competitor presence reduces internal attentional focus and improves 16.1 km cycling time trial performance. *Journal of Science and Medicine in Sport* (in press).
- Williams, E.L., Jones, H.S., Sparks, S.A., Marchant, D.C., Micklewright, D., and McNaughton, L.R. (2014b) Deception studies manipulating centrally acting performance modifiers: A review. *Medicine and Science in Sports and Exercise*, 46(7), 1441-51.
- Williamson, J.W., McColl, R., Mathews, D., Mitchell, J.H., Raven, P.B., and Morgan, W.P. (2001) Hypnotic manipulation of effort sense during dynamic exercise: Cardiovascular responses and brain activation. *Journal of Applied Physiology*, 90(4), 1392–9.
- Wilmore, J.H. (1968) Influence of motivation on physical work capacity and performance. *Journal of Applied Physiology*, 24(4), 459-63.
- Wilson, M.G., Lane, A.M., Beedie, C.J., and Farooq, A. (2012) Influence of accurate and inaccurate “split-time” feedback upon 10-mile time trial cycling performance. *European Journal of Applied Physiology*, 112(1), 231–6.
- Wooles, A., Keen, P., and Palfreeman, R. (2003) Protocols used for the physiological testing of the Great Britain Cycling Team. Test Methods Manual.
- Wright, R.A. (1996) Brehm’s theory of motivation as a model of effort and cardiovascular response. In: P.M. Gollwitzer and J.A. Bargh (Eds.) *The Psychology of Action: Linking Cognition and Motivation to Behavior* (pp 424–53). New York, USA: Guilford.
- Zimmerman, B.J. (2000) Attaining self-regulation: A social cognitive perspective. In: M. Boekaerts, P.R. Pintrich, and M. Zeidner (Eds.) *Handbook of Self-Regulation* (pp 13–39). San Diego, CA: Academic Press.

Appendices

Appendix 1

PARTICIPANT INFORMATION SHEET AND INFORMED CONSENT (Study 1)

Project title: **The importance of perceptual and physiological responses in pacing strategy in 16.1km and 40km cycling time-trials**

Lead investigator: Hollie Jones

Affiliation: Department of Sport and Physical Activity, Edge Hill University, Ormskirk

Research Team Members: The lead supervisor of the project is Professor Lars McNaughton. Other Research Staff are Emily Williams, Dr Andy Sparks, Dr David Marchant, Dr Craig Bridge and Dr Adrian Midgley.

Thank you for showing an interest in this project. Please read all the information carefully. Think about whether or not you want to take part. If you decide to take part, you will be asked to sign this form. You do not have to take part. If you decide that you do not want to participate, there will be no disadvantage to you.

Purpose of the study

The main aim of the study is to investigate the use of two novel scales in 16.1 km and 40 km cycling time-trials. A Physical Ratings of Perceived Exertion (P-RPE) scale and Task Effort and Awareness (TEA) scale will be evaluated as a possible replacement of the traditional Ratings of Perceived Exertion scale.

Procedures

If you agree to take part, you will be asked to visit the sports psychology laboratory at Edge Hill University on five occasions. Each visit should last between one and two hours in duration.

Visit 1: Pre-exercise screening will consist of initial measurements of height and weight, collection of participant details (e.g. training background) and familiarisation of the facilities, equipment and measurement tools to be used throughout the study. The two novel scales to be used are the Physical Ratings of Perceived Exertion scale and the Task Effort and Awareness scale of which you will be familiarised with on this visit. Understanding of the scales will be confirmed prior to any trials. The first of two self-paced familiarisation time trials, either a 16.1 km or 40 km trial, will then be completed. This trial and all further time trials will be completed in the fastest time possible and on your own bike using an electronically-

braked cycle ergometer (CompuTrainer turbo trainer). A projection of your performance during the trial will be displayed by an on-screen computer avatar.

Visit 2: The other familiarisation trial (either 16.1 km or 40 km) will be completed, as conducted on visit 1.

Visits 3 and 4: These visits will consist of the experimental 16.1 km and 40 km time-trials. The order of these two trials will be randomised, but you will be informed of the distance prior to the visit.

Visit 5: You will complete a maximal aerobic test on a laboratory-based cycle ergometer (SRM) to determine your peak oxygen uptake (VO_{2peak}). A body composition evaluation will also take place during this visit, calculating percentages of fat- and fat-free mass, using Air Displacement Plethysmography (BodPod).

Respiratory gas analysis will be used for brief periods in each trial and will require you to wear a mouthpiece. Measurements of heart rate will also be obtained using a Polar heart rate monitor throughout the exercise bouts and capillary blood samples will be taken pre and post trials. In the 24 hours before the first visit, you will be required to record a diet diary which will then be replicated prior to each subsequent session. In the preceding 24 hours to each visit, you will need to refrain from strenuous exercise, and alcohol and stimulant consumption. 500 ml of water should be consumed in the 2 hours prior to each visit to ensure you are well hydrated for the exercise, which will be assessed prior to each trial.

Benefits of participation

Following completion of the study, performance feedback will be provided, including your VO_{2max} value, lactate threshold, body fat percentage, watts per kg, completion times and heart rate, speed, cadence and power output profiles for each trial.

Risks and discomfort

Risks and discomforts have been assessed to be minimal whilst participating. Associated risks of participating in exercise may include nausea, mental and physical exhaustion, dizziness and muscle cramps or soreness. There may be a risk of experiencing claustrophobia whilst in the BodPod. The blood sampling procedure will require a small capillary sample to be collected from the fingertip using a lancet which is relatively pain free but can cause faintness or discomfort if the participant has an aversion to the sight of blood. If you experience pain or discomfort, please tell the researcher immediately. A trained first aider will also be present at each trial. Full details of the risks involved in the procedures are detailed in risk assessments which are located in the department health and safety manual and

available upon request. All exercise will be self-paced and you are able to terminate each trial voluntarily at any point.

Safety

General health and safety procedures will be followed as detailed in the department health and safety manual. Suitable screening will be carried out involving risk stratification and resting measurements.

Declaration

I confirm that I have volunteered to take part in this study, 'The independent responses of the physical sensations and psychological sense of effort cues of perceived exertion in 16.1km and 40km cycling time-trials', and I am satisfied with the information that has been provided regarding my participation and with the answers to any further questions I have asked. I understand that I am eligible to withdraw from the study at any time prior to, during or after my participation. I am fully aware that all the information collected will remain totally confidential and I agree to the information being saved and analysed using electronic means, in accordance with the Data Protection Act 2003.

Participant's full name:

Signed (Participant): **Date:**

Signed (Witness): **Date:**

Signed (Investigator): **Date:**

Contact Details

Hollie Jones
Edge Hill University
St Helens Road
Ormskirk
Lancashire
L39 4QP
Email: hollie.jones@edgehill.ac.uk
Work Tel: 01695 657344
Mobile: 07817930901

Appendix 2

PARTICIPANT INFORMATION SHEET AND INFORMED CONSENT (Studies 2 and 3)

Project title: Effects of visual feedback on pacing strategy in 16.1km cycling time trials

Lead investigator: Hollie Jones

Affiliation: Department of Sport and Physical Activity, Edge Hill University, Ormskirk

Research team members: The lead supervisor of the project is Professor Lars McNaughton. Other research staff are Emily Williams, Dr Andy Sparks, Dr David Marchant, Dr Craig Bridge and Professor Adrian Midgley.

Thank you for showing an interest in this project. Please read all the information carefully. Think about whether or not you want to take part. I will contact you again to ask you about your decision. If you decide to take part, you will be asked to sign this form. You do not have to take part. If you decide that you do not want to participate, there will be no disadvantage to you.

Purpose of the study

The main aim of the project is to investigate the effects of visual feedback provided via computer simulated software on pacing strategy in 16.1km cycling time trials.

Procedures

If you agree to take part, you will be asked to visit the psychology laboratory at Edge Hill University on five occasions within a 3 week period. Each visit should last between 60 and 90 minutes in duration.

- Visit 1) Initial measurements of height and weight will be taken and a record of participant details (e.g. training background, medical history). You will then be required to complete a maximal incremental aerobic test on a laboratory-based cycle ergometer (Lode Excalibur) to determine your peak oxygen uptake (VO_{2peak}).
- Visits 2-5) Following familiarisation of the facilities, equipment and measurement tools to be used throughout the study, a maximal effort self-paced 16.1km cycling time trial will be completed on each visit. You will complete all four of these trials on your own bike which will be set up on an electronically-braked cycle ergometer (CompuTrainer turbo trainer). Computer software will project your performance on a flat, virtual course on a large screen in front of you. Different visual feedback will be provided on the screen in the trials and distance covered will be the only numerical feedback provided.

Respiratory gas analysis will be used which will require you to wear a mouthpiece and nose clip at intervals during the time trials and a face mask will be worn throughout the maximal incremental aerobic test. A heart rate monitor will be worn in all sessions and capillary blood samples will be taken before, during and after each time trial. This requires a small sample of blood to be collected from the fingertip using an automated lancet. In the initial visit, familiarisation and description of a number of psychological scales will be provided as they will be presented prior to, during and post each trial. Each time trial will be performed with maximal effort and in the fastest time you can complete it.

Control measures

It is important to arrive for each visit to the laboratory in a similar physiological and psychological state, therefore a number of quality control checks will be in place. In the 24 hours prior to each visit, you will need to refrain from strenuous exercise and alcohol consumption and also follow your usual diet. A 24 hour nutritional diary should be recorded and presented to the investigators on your first visit and replicated as similarly as possible before each subsequent trial. A minimum of 500 ml of water should be consumed in the 2 hours prior to each visit and your hydration status will be assessed prior to each trial. Failure to meet these control measures may result in a delay or cancellation of the testing that day.

Benefits of participation

Following completion of the study, performance feedback can be provided upon request, including your VO_{2peak} value, max heart rate, max watts and watts per kg from the maximal aerobic test and completion times, average heart rate, average speed and average power output from each time trial. Comparisons between predicted, actual and post-trial perceptions of pacing strategies can be provided for each trial, in addition to classification of psychological traits. By taking part you will be aiding us to enhance our understanding and knowledge of the research area.

Risks and discomfort

Associated risks of participating in exercise may include nausea, mental and physical exhaustion, dizziness and muscle cramps or soreness. The blood sampling procedure is relatively pain-free but can cause faintness or discomfort if the participant has an aversion to the sight of blood. If you experience pain or discomfort, please tell the researcher immediately. A trained first aider will also be present at each trial. Full details of the risks involved in the procedures are detailed in risk assessments which are located in the department health and safety manual

and available upon request. All exercise will be self-paced and you are able to terminate each trial voluntarily at any point.

Safety

General health and safety procedures will be followed as detailed in the department health and safety manual. Suitable screening will be carried out involving risk stratification, and resting measurements.

Declaration

I confirm that I have volunteered to take part in this study and I am satisfied with the information that has been provided regarding my participation and with the answers to any further questions I have asked. I understand that I am eligible to withdraw from the study at any time prior to, during or after my participation. I am fully aware that all the information collected will remain totally confidential and I agree to the information being saved and analysed using electronic means, in accordance with the Data Protection Act 2003.

Participant's full name:

Signed (Participant):**Date:**

Signed (Witness):**Date:**

Signed (Investigator):**Date:**

Contact Details

Hollie Jones

Edge Hill University

St Helens Road

Ormskirk

Lancashire

L39 4QP

Email: hollie.jones@edgehill.ac.uk

Work Tel: 01695 657344

Mobile: 07817930901