

Latent thermal energy storage technologies and applications: A review

Hussam Jouhara^{a,*}, Alina Żabnieńska-Góra^a, Navid Khordehghah^a, Darem Ahmad^a, Tom Lipinski^b

^a College of Engineering, Design and Physical Sciences, Brunel University London, UB8 3PH, UK

^b ThEnergy Ltd., 38a Cumberland Rd, Hanwell, London W7 2EB, UK

ARTICLE INFO

Article History:

Received 25 April 2020

Revised 23 June 2020

Accepted 7 July 2020

Available online 17 July 2020

Keywords:

Phase change materials

Thermal energy storage

Latent heat storage

Thermochemical energy storage

Classification of PCMs

PCM applications

ABSTRACT

The achievement of European climate energy objectives which are contained in the European Union's (EU) "20–20–20" targets and in the European Commission's (EC) Energy Roadmap 2050 is possible, among other things, through the use of energy storage technologies. The use of thermal energy storage (TES) in the energy system allows to conserving energy, increase the overall efficiency of the systems by eliminating differences between supply and demand for energy.

The article presents different methods of thermal energy storage including sensible heat storage, latent heat storage and thermochemical energy storage, focusing mainly on phase change materials (PCMs) as a form of suitable solution for energy utilisation to fill the gap between demand and supply to improve the energy efficiency of a system. PCMs allow the storage of latent thermal energy during phase change at almost stable temperature. The article presents a classification of PCMs according to their chemical nature as organic, inorganic and eutectic and by the phase transition with their advantages and disadvantages. In addition, different methods of improving the effectiveness of the PCM materials such as employing cascaded latent heat thermal energy storage system, encapsulation of PCMs and shape-stabilisation are presented in the paper. Furthermore, the use of PCM materials in buildings, power generation, food industry and automotive applications are presented and the modelling tools for analysing the functionality of PCMs materials are compared and classified.

© 2020 The Author(s). Published by Elsevier Ltd. This is an open access article under the CC BY license.

(<http://creativecommons.org/licenses/by/4.0/>)

Abbreviations

AA-CAES	advanced adiabatic compressed air energy storage
ANN	artificial neural network
CFD	computational fluid dynamics
CLHTES	cascaded latent heat thermal energy storage
CSP	concentrating solar power
CTES	cool thermal energy storage
DHC	systems district heating and cooling systems
DHW	domestic hot water
DPSFPC	double-pass solar flat plate collector
DSC	differential scanning calorimeter
ECM	electrochemical model
ESS	energy system simulation
EV	electric vehicles
FEMs	finite element methods
GNPs	graphite nano-platelets
HEVs	hybrid electric vehicles

HTF	heat transfer fluid
HVAC	heating, ventilation, and air conditioning
LHS	latent heat storage
LHTES	latent heat thermal energy storage
LIBs	lithium-ion batteries
MPCM	microencapsulated phase change materials
MWCNT	multi-walled carbon nanotubes
NVP	night ventilation system
P2H2P	power-to-heat-to-power
PCM	phase change materials
PCT	phase change temperature
PV system	photovoltaic system
PV/T system	photovoltaic-thermal system
RSPCM	roof with outer-layer shape-stabilised phase change material
SHS	sensible heat storage
SS-PCMs	solid-solid phase change materials
TABS	thermally activated building structures
TCES	thermochemical energy storage
TES	thermal energy storage
UTES	underground thermal energy storages

* Corresponding author.

E-mail address: Hussam.Jouhara@brunel.ac.uk (H. Jouhara).

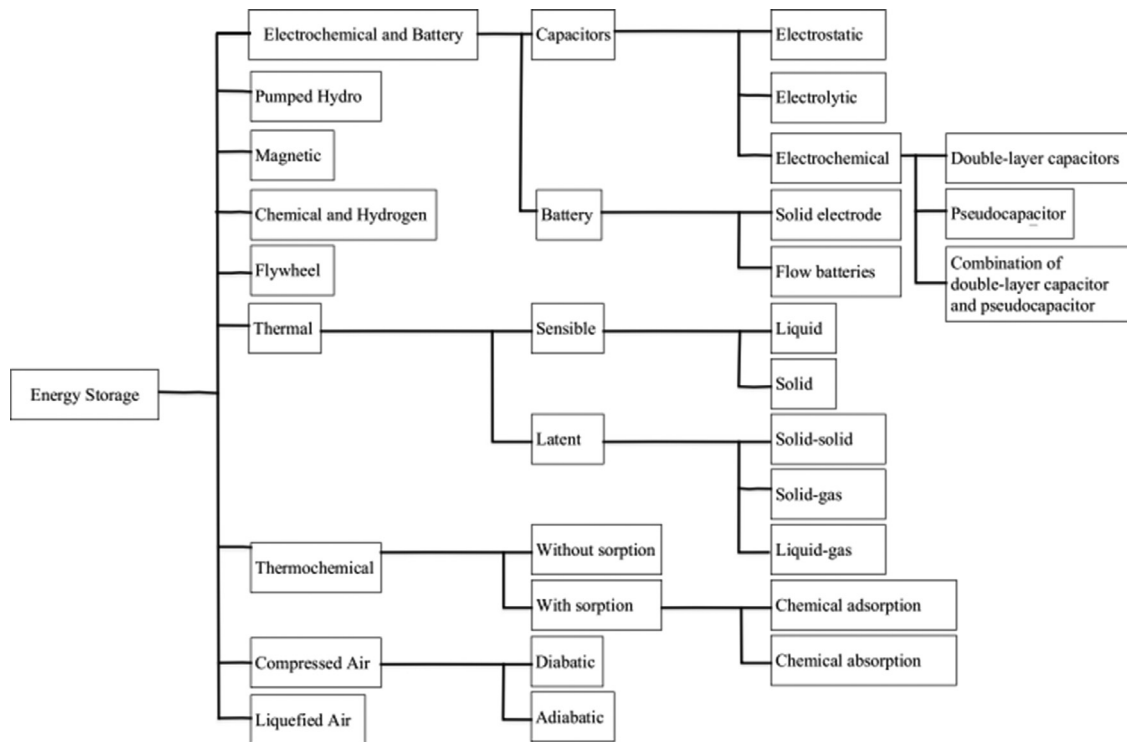

Fig. 1. A classification of energy storage types (reproduced from [7]).

1. Introduction

The European Union's policy objective is to move towards a low-carbon economy, with at least a 40% reduction in greenhouse gas emissions by 2030. This is due to the fact that heating and cooling of buildings consume almost half of the EU's energy [1]. In addition, significant amount of thermal energy is a by-product of other energy applications are usually not collected and not used efficiently [2]. The achievement of Europe's climate energy targets, which are included in the European Union (EU) 20–20–20 targets and the European Commission (EC) Energy Roadmap 2050, is made possible by using energy storage technology [3] which provides flexibility and supports the integration of renewable energy into the energy system.

The storage of thermal energy is possible by changing the temperature of the storage medium by heating or cooling it. This allows the stored energy to be used at a later stage for various purposes (heating and cooling, waste heat recovery or power generation) in both buildings and industrial processes. The use of Thermal Energy Storage (TES) in the energy system allows to conserving energy, increase the overall efficiency of the systems by eliminating differences between supply and demand for energy [4], reduce investment and running costs as well as to reduce carbon dioxide (CO₂) emissions and other environmental pollutants [5]. In addition, the use of renewable, low-

carbon energy sources can be improved, especially with solar technologies and Power-to-Heat concepts [6].

According to [7] energy storage can be divided into several types: thermal energy storage (sensible and latent) electrochemical and battery energy storage (capacitors and battery), thermochemical energy storage (with and without sorption), pumped hydro and magnetic energy storage, flywheel energy storage, compressed air energy storage (diabatic and adiabatic), chemical and hydrogen energy storage, Fig. 1.

2. Thermal energy storage

Below it is an overview on the different methods of thermal energy storage. This can be classified on physical processes (sensible heat and latent heat) and chemical processes as shown on Fig. 2 [7–12]. These processes differ significantly in the method of thermal energy storage [6].

Many parameters have to be considered while selecting TES material. The most important of these are: high energy storage density, cyclability, mechanical strength, chemical stability and low corrosion of storage vessels.

The basic parameter determining the dynamics of change in the TES system (charging and discharging) is thermal conductivity. The low thermal conductivity reduces energy generation [13]. Palacios et al. [14] pointed out the lack of thermal conductivity measurement standards

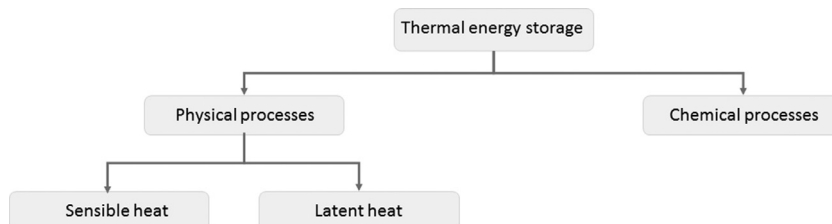

Fig. 2. Methods for thermal energy storage.

Table 1
Different requirements of TES materials and systems indicating reasons.

		Requirements	Reason
Material	Chemical	Long-term chemical stability	Along the cycling periods maintains initial thermochemical properties
		No fire and explosion hazard	Workplace safety
		No toxicity	Safety of operation
		No phase separation / incongruent melting	Avoiding changes on the stoichiometric composition of melt
	Kinetic	Compatibility with storage materials and low reactivity to heat transfer fluids (HTFs)	Long lifetime of the container and the Long lifetime of shell materials
		Small or no sub cooling	Maintaining the same melting/solidification temperature and avoiding heat release problems
	Physical	Sufficient crystallisation rate	Compliance with recovery system heat transfer demands
		High density	reduction of the volume occupied by the TES material
	Thermal	Low vapour pressure	Minimising the chemical and mechanical stability requirements of the s or vessel
		Small volume changes (low density variation)	Possibility of using eutectic mixtures
Favourable phase equilibrium		Providing significant sensible heal storage	
High specific heat		Increasing heat transfer within the TES material through minimum temperature gradients	
Material/system	High thermal conductivity in both solid and liquid states		Ensuring efficient charging and discharging processes within the operation conditions
	Melting / solidification temperature in the desired operating temperature range		Ensuring significant latent heat storage in small volumes
	High latent heat of transition per unit volume near temperature of use		Providing the complete melt of the TES material and their homogeneity
	Economic	Congruent melting	Cheaper
		Abundant and available	During the lifetime of the TES system Avoiding maintenance and replacements
	Environmental	Large lifetime	Competitive
		Cost effective	
		Low manufacturing energy	Reducing the environmental impact of the systems and implementing standards and sustainable regulations
	Technological	Easy recycling and treatment	
		Low CO ₂ , footprint and use of by-products Non-polluting	
Operational strategy		Process optimisation	
Integration into the facility		Enhancing the heat transfer from the TES material to the HTF and vice versa	
Efficiency improvement suitable heat transfer			

and in a literature review they discussed the methods that until now have been used to characterise TES materials focusing on steady-state conditions methods (like heat flow metre and guarded hot plate) and transient conditions methods An additional criterion to be considered for the selection of TES material is operating temperature, peak load, duty cycle, ease of control and wider system integration.

Table 1 classifies the different requirements of TES materials and systems in terms of an optimum chemical, kinetic, physical, thermal, economic, environmental and technological, performance [8,15].

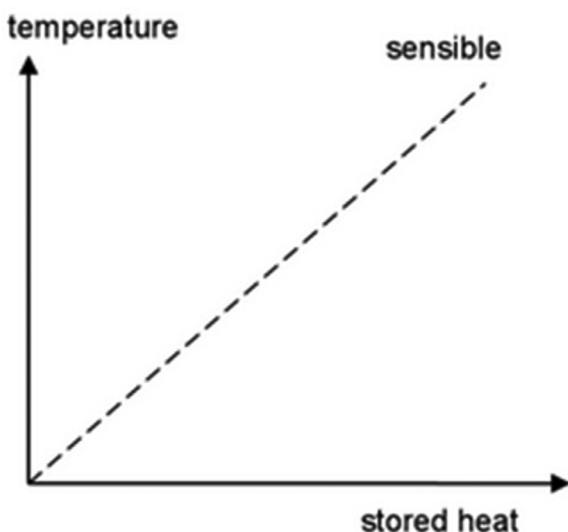

Fig. 3. Temperature increase during sensible heat storage [8].

2.1. Sensible heat storage

Sensible heat storage (SHS) is by far the most common method for heat storage [8]. It is the simplest and easiest form of heat storage technology [12]. Sensible heat is the heat exchanged by a system that does not change its phase but changes the temperature of a storage medium. The temperature changes linearly in relation to the stored heat. Fig. 3 depends on specific heat capacity of the material. This method of energy storage has its disadvantages, which include low energy density and loss of thermal energy at any temperature [9].

Absorption and release of heat energy in the storage medium can take place through radiation, convection and conduction. and is described by the formula below [12,16]:

$$Q = mC_p(T_f - T_i) \tag{1}$$

where:

Q- quantity of the sensible heat storage of a material;

m – mass of storage material;

C_p - specific heat;

T_f difference between final temperature (T_f) and initial temperature (T_i).

The most commonly used SHS storage material is ceramics as well as water and oil. They can be applied in both industrial and residential solutions for example: hot water storage on district-heating networks or building materials which store energy for several months thanks to their high thermal capacity [9]. Commonly applicable SHS systems include solutions using underground energy storage such as: borehole, aquifer, cavern, ducts in soil, pit hot water storage (hydro-accumulation), and rock filled storage (rock, pebble, gravel) [7].

2.2. Latent heat storage

Latent heat storage (LHS) is the transfer of heat as a result of a phase change that occurs in a specific narrow temperature range in the relevant material. The most frequently used for this purpose are: molten salt, paraffin wax and water/ice materials [9].

According to [6] there are two systems of storage of latent heat differing in terms of heat transfer: direct and indirect. We talk about a direct system when heat transfer takes place through direct contact between the heat transfer fluid (HTF) and the LHS material and an indirect system when there is a solid heat transfer border between HTF and LHS material.

Phase changes include processes leading to a change in the state of aggregation: evaporation and condensation, crystallisation and melting and occurring without a change in the state of aggregation, in the solid or liquid phase. In this process it is possible to store a large amount of heat or cold depending on the properties of the selected material. With the temperature increase, the phase change from solid to liquid occurs with a small change in volume, usually less than 10% [8] and the pressure does not change significantly. All this makes the melting and solidification of the stored material take place at a constant temperature, known as phase change temperature (Fig. 4). When the melting is completed, further heat transfer causes sensible heat to be stored again.

The stored heat is equal to the enthalpy difference ΔH between the solid and liquid phase [8]:

$$\Delta Q = \Delta H = m \Delta h \quad (2)$$

The internal molecular system changes in solid-liquid phase change materials when the temperature exceeds the critical threshold (i.e. the phase transition temperature). The nucleation process begins depending on the cooling rate, the type of particles and the presence of impurities when the temperature drops below the phase transition temperature [4].

Materials changing the solid-solid phase are characterised by high energy storage density and small volume changes. In addition, they are not at risk of leakage and do not require encapsulation. Thus, they are more likely to be used than solids and liquids [4].

The boundary conditions affect the phase change temperature for liquid-gas transformations. Usually it is connected with a pressure and a temperature difference between charging and discharging [8]. The energy storage density in LHS systems is more efficient than in SHS systems because they use the transformation of chemical bonds in the mass structure of the material [9].

Latent heat capacity of a material can be defined as [12]:

$$Q = mC_p dT(s) + mL + mC_p dT \quad (3)$$

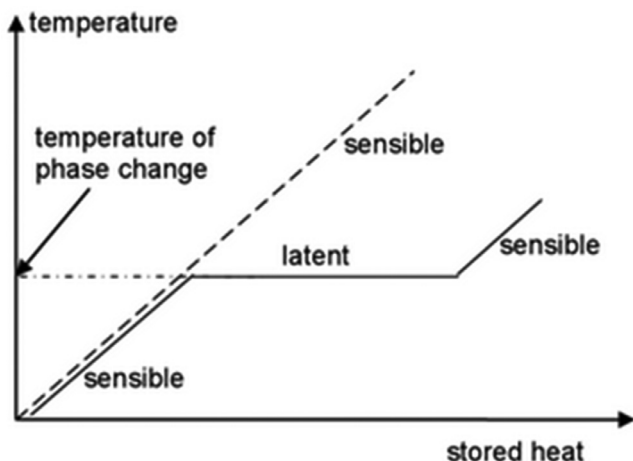

Fig. 4. Heat storage as latent heat for the case of solid-liquid phase change [8].

Where m is the mass of the phase change material (kg), L is the enthalpy of fusion and dT is the temperature difference. The above equation describes the sensible heat of the solid phase, latent heat of fusion, and sensible heat of the liquid phase.

Typical phase change materials (PCM) based on paraffin waxes, esters, fatty acids and hydrochloric hydrates used in waste heat recovery systems, solar heating systems leading to energy savings in buildings [17].

Geometric, operational and design parameters should be taken into account in assessing the energy performance of TES latent heat. The energy and exergy performance for latent thermal energy storage with various influence factors have been comprehensively reviewed in [17] including the HTF mass flow rate, HTF inlet temperature, PCM melting temperature and number, additives for PCMs, reference temperature, storage unit dimension, heat exchanger surface enhancement, and sensible heating and sub-cooling. Depending on whether an energy or exergy analysis should be carried out, the first or second law of thermodynamics is used respectively. Following [18] it is possible to determine how much heat or cold is stored during the charging and discharging process, as well as during the overall process. Usually the latent thermal energy storage performance can be assessed with the energy analysis and exergy analysis as the following equations:

Charging process:

$$\eta_{charging} = \frac{\int \dot{Q}_{stored} dt}{\int \dot{Q}_{supplied} dt} = \frac{Q_{stored}}{Q_{supplied}} \quad (4)$$

Discharging process:

$$\eta_{charging} = \frac{\int \dot{Q}_{used} dt}{\int \dot{Q}_{stored} dt} = \frac{Q_{used}}{Q_{stored}} \quad (5)$$

Overall process:

$$\eta_{charging} = \frac{\int \dot{Q}_{used} dt}{\int \dot{Q}_{supplied} dt} = \frac{Q_{used}}{Q_{supplied}} \quad (6)$$

The heat storage ratio, which is the ratio of the total energy stored in the system to the maximum energy stored in the system, and the heat release factor are used to evaluate energy performance. Ratio of heat storage:

$$Ratio_{heatstorage} = \frac{\int \dot{Q}_{stored} dt}{Q_{maximum}} = \frac{Q_{stored}}{Q_{maximum}} \quad (7)$$

Heat release ratio is the ratio of the total energy released from the system over the maximum energy stored in the system.

$$Ratio_{heatstorage} = \frac{\int \dot{Q}_{released} dt}{Q_{maximum}} = \frac{Q_{released}}{Q_{maximum}} \quad (8)$$

In general, when an energy analysis is carried out, it is not possible to determine the quality of the energy transmitted, but only its quantity during the charging and discharging process [17].

The exergy analysis can provide the quality of energy charging and discharging during the storage process and shows the directions for optimising the TES system.

Charging process:

$$\psi_{charging} = \frac{\int \dot{E}x_{stored} dt}{\int \dot{E}x_{supplied} dt} = \frac{E_{x_{stored}}}{E_{x_{supplied}}} \quad (9)$$

Discharging process:

$$\psi_{discharging} = \frac{\int \dot{E}x_{used} dt}{\int \dot{E}x_{stored} dt} = \frac{E_{x_{used}}}{E_{x_{stored}}} \quad (10)$$

Overall process:

$$\psi_{\text{overall}} = \frac{\int \dot{E}x_{\text{used}} dt}{\int \dot{E}x_{\text{supplied}} dt} = \frac{E x_{\text{used}}}{E x_{\text{supplied}}} \quad (11)$$

The number of entropy generation (N_s) allows to estimate the energy performance. By reducing N_s the system exergy performance can be improved. The exergy efficiency can also be expressed as [17]:

$$\psi = 1 - N_s \quad (12)$$

2.3. Thermochemical storage

Thermochemical energy storage (TCES) is characterised by high energy density, high exergetic efficiency, and high operating temperature [18]. Thermochemical energy storage is achieved via a reversible chemical reaction. In the chemical bonds of the molecules involved in the charge/discharge cycle, potential chemical energy is retained [19]. This type of energy storage has the highest energy density of any TES but this type of energy storage has the highest energy density of all TES, but the reaction efficiency decreases with time [9].

The thermochemical energy storage materials should exhibit high reaction enthalpy, fast reaction kinetics, high thermal conductivity, good cyclic stability. Also, TCES materials should be abundant, non-toxic and economic, with no side reactions [18]. The thermochemical material, that is used to store thermochemical energy, is either physically reversible process with two substances, or a reversible chemical reaction as follows [12]:



For the storage of thermochemical energy, it is necessary to supply to the system proper amount of heat Q to dissociate substances A and B . Depending on the direction of the reaction, there is an endo or exo thermal reaction.

In the article [18] the authors have attempted to classify high temperature TCES focusing on experimental studies carried out on solid-gas, gas-gas, and sulfuric acid/sulfur-based thermochemical energy storage systems that operate above 300 °C. In this study [20], the impact of air pollutants on the performance of thermochemical heat storage materials during the building's lifetime (at least 30 years of use) has been examined. Critical pollutants were chosen, and ageing tests were performed to model the storage material implementation

in a long-term application and in successive hydration/dehydration cycles. Adsorption tests (performed under static and dynamic conditions) were carried out on zeolite-base materials, using different molecules representative of the pollutants (toluene, styrene and hexaldehyde), chosen as model molecules. Then the cycled materials were deeply characterised to shed light on the changes in their properties and correlate them with the loss in heat storage capacity.

In their analyses, researchers most often consider the influence of a single medium on the thermal energy storage while X. Sun et al. [21] studied the combination influence of HTF temperature, velocity and configuration inclination.

Fig. 5 presents the application of SHS, LHS, TCES [6]. Most of them aim at increasing the flexibility and energy efficiency of the systems by balancing energy demand and supply.

3. Phase change materials

Numerous methods of TES have been developed, nevertheless PCM are substances that are able to absorb, accumulate and release a large amount of energy per unit of mass in the range of phase transition temperature that's why they're so widespread [22] and used in numerous TES applications [16]. Energy savings can be achieved by using PCM in heat recovery systems or solar energy systems [22]. PCM can be used in building solutions in many ways [23] and it will be discussed in more detail in Section 8 [23].

Latent heat thermal energy storage (LHTES) based on phase change material (PCM) plays a significant role in saving and efficient use of energy, dealing with mismatch between demand and supply, and increasing the efficiency of energy systems [24]. PCMs have the potential to store thermal energy, during phase change, at an nearly constant temperature and they ensure a much higher density of thermal energy storage than sensible thermal energy storage material therefore are widely used to store latent heat [4,12]. Additionally, compared to SHS systems, LHS systems result lower costs by requiring a smaller weight and volume [25].

The melting point (melting temperature and the melting enthalpy) is one of the primary considerations while choosing a PCM material [8,26]. Taking into account the environment in which the PCM material is to work, its melting point should be lower than the heat supply temperature and higher than the ambient temperature [26].

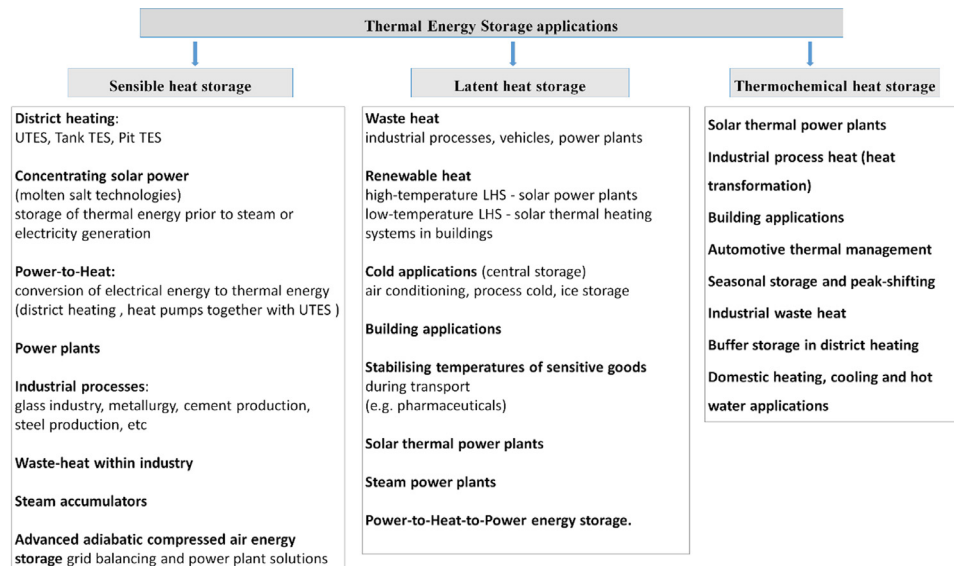

Fig. 5. Application of SHS, LHS, TCES.

The selection of TES material is a very difficult task given the number of parameters to be taken into account. The ideal PCM should be characterised by Mehling et al. [8,9,26,25]:

- Adequate phase transition temperature to meet the needs of practical use;
- High melting enthalpy ensuring the high latent heat storage capacity;
- Faster discharging and charging due to high thermal conductivity;
- Persistent chemical and thermal properties to provide the rigid thermal storage capacity;
- Non-toxic, non-flammable, non-corrosive and non-explosive to provide safety and avoid harm to surroundings;
- Compatibility with the construction materials;
- Small enough supercooling;
- Subtle volume variation during phase transition;
- High nucleation rate range;
- Adequate rate of crystallisation;
- High latent heat of phase transition per unit volume;
- High specific heat for sensible thermal changes;
- Fully reversible freeze/melt cycle storage;
- Low vapour pressure at the operating temperatures for safety;
- Positive phase equilibrium;
- Abundant and easily available, low cost;
- Good recyclability for environmental and economic reasons.

In practice, there are no commercially available PCMs that fully meet all thermal, chemical, physical, kinetic and economical requirements to date [9,26]. Each group has its own advantages and disadvantages to consider for each specific application.

There are many criteria for classifying PCM materials. Their chemical nature can be considered as organic which include mainly paraffins or non-paraffins such as esters, fatty acids, alcohols and glycols or polymers i.e. PEG, inorganic with salt hydrates and/or alloys and metals and eutectic with mixed PCMs as organic–organic, inorganic–inorganic and inorganic–organic. PCMs can also be characterised in terms of their phase change as solid–liquid PCMs, solid–solid PCMs, solid–gas PCMs and liquid–gas PCMs [9]:

According to their shape stabilisation can be nano, micro and macro encapsulation. The classification is shown in Fig. 6. Fig. 7 indicates an overview of latent heat storage by the phase transition of PCM.

In the paper [27], the analysis on the available data for structure, preparation of material, thermal conversion, reaction enthalpies, carbonation durability, and ionic substitution of ettringite has been established. Moreover, potential research directions and solutions to

improve thermal performance of ettringite-based materials are proposed. Table 2 presents classification and properties of PCM according to their chemical nature.

Fallahi et al. [4] analysed the relationship between thermal properties Solid–Solid-PCMs (SS-PCMs) like enthalpy and phase transition temperature and their internal structure focusing on the possibility of their use depending on four different molecular structures described in the literature. In Table 3 summary is given of the relative ratings of advantages and disadvantages for different types of SS-PCMs.

3.1. Organic material

Among the organic materials known as natural and there are three basic groups of substances: paraffins, fatty acids, and organic mixtures. Organic PCM materials have their advantages and disadvantages that make them competitive with inorganic materials. On the one hand, they are thermally and chemically stable, they are non-corrosive to metals, recyclable and have high latent heat of fusion. On the other hand they are flammable, have lower phase change enthalpy, low thermal conductivity and additionally poor compatibility with polymer containers or encapsulation media [9].

Paraffin due to its crucial properties consisting of a high heat of fusion, fluctuated stage change temperature, high phase change enthalpy, zero super cooling characteristics, lower vapour pressure, and being chemically inert (without corrosion and toxicity), with constant conductivity cyclic stability has been applied for energy storage [26,28].

Therefore, and bearing in mind that it has different melting points, it can be used to enhance indoor thermal performance by using it in double-glazed units, thereby reducing the energy demand of the building [28]. Some inevitable drawbacks of paraffin limit its application in practice, such as low thermal conductivity (about 0.2–0.4 W/m K and high volume expansion during phase transition [22,28]. In solar drying of agro-products applications paraffin wax, a petroleum-derived (usually alkanes) with the chemical formula C_nH_{2n+2} , is primarily applied [26].

Fatty acid is a type of organic material (renewable PCM called non paraffin) because it is produced by plants and animals and has perfect thermal and physical properties.

Different encapsulation methods should be used to prevent leaks and increase the storage capacity of organic material. Fig. 8 presents advantages and disadvantages of organic PCMs.

3.2. Inorganic PCMs

Inorganic solids PCM (SS-PCM) are able to store/release heat energy in the solid phase through one or a combination of energy storage techniques such as magnetic transformations, crystallographic structure transformations, order–disorder transformations, transformations between amorphous structure and crystal structure, In particular, the first two methods use large amounts of latent heat [4].

Thus, inorganic PCMs are characterised by lower cost, high phase change enthalpy and comparably better thermal conductivity. Their disadvantage is their corrosive nature, sub-cooling, segregation and phase separation and potential thermal instability [9]. Therefore, they are best suited for industrial plants to recover heat from high-temperature waste heat [4].

One of the forms of inorganic materials are metallic foams. They are characterised by good stability, low density and high ratio coefficient, which increase their thermal conductivity in relation to nanoparticles. However, the size of the pores has very little influence on the thermal conductivity [29].

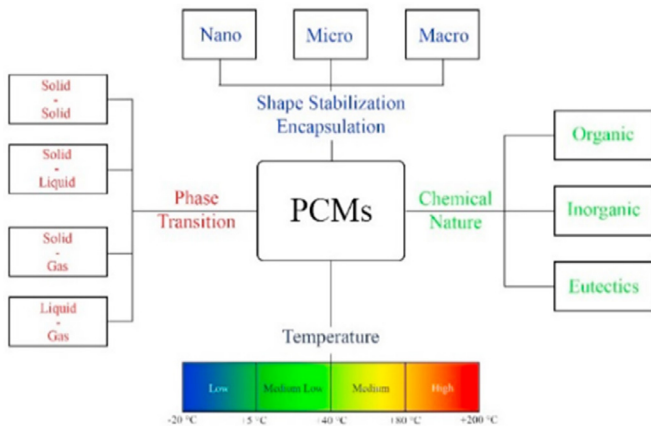

Fig. 6. Classification of PCMs (reproduced from [9]).

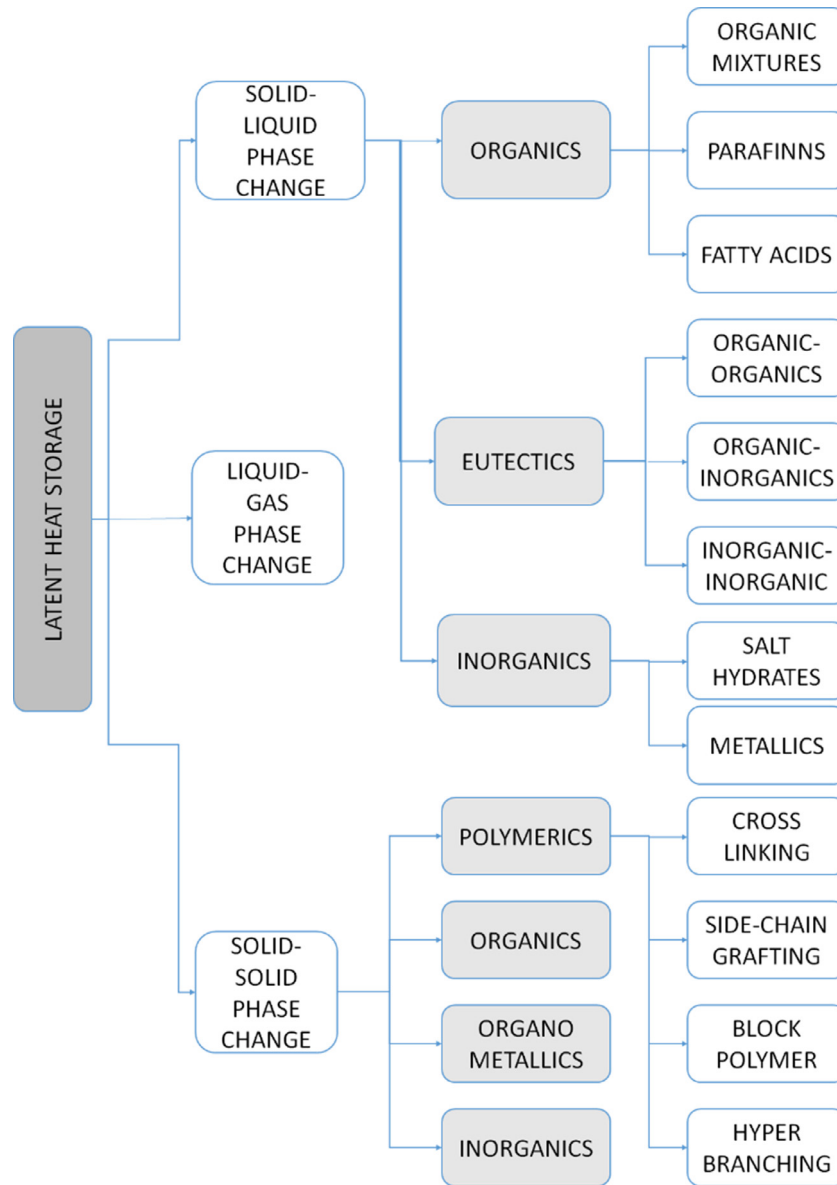

Fig. 7. Overview of latent heat storage by the phase transition of PCM [26,18,22].

Table 2
Classification and properties of PCM according to their chemical nature [16].

Phase change materials Organic	Inorganic	Eutectics
(1) These are the polymers of long chains of carbon and hydrogen molecules e.g. Paraffin (C _n H _{2n}).	(1) High heat of fusion	(1) Sharp melting point
(2) No supercooling	(2) High thermal conductivity	(2) High volumetric thermal storage
(3) Available in wide ranges of temperatures.	(3) Low volume change	(3) High cost
(4) Physically and chemically stable.	(4) Easily available	(4) Limited data availability about properties
(5) High heat of fusion	(5) Non flammable	
(6) Ability to melt congruently	(6) Supercooling	
(7) Flammable	(7) Lead to corrosion	
(8) Exhibits low thermal conductivity	(8) Not melting congruently	
(9) Low volumetric energy intensity	(9) High volumetric energy intensity	

Table 3

Summary of relative ratings of advantages and disadvantages for different types of solid-solid-PCMs [4]. (+ Poor, ++ Fair, +++ Good, ++++ Excellent).

Property	Polymeric	Organic	Organometallic	Inorganic
Transition temp. (°C)	11–65	25–190	32–160	680–988
Enthalpy (J/g)	10–205	15–270	62–154	34–56
Thermal conductivity	+	+	+++	++++
Phase change kinetics	+	+	+++	+++
Phase separation	++++	++	+++	++++
Chemical & thermal stability	+++	+++	+++	++++
Volume change	++	++	++++	++++
Non-toxicity	+++	+	++++	++++
Fire resistance	+	+	++	++++
Ease of production	+++	+++	+	++++

3.3. Eutectic

Eutectic phase change materials involve a combination of two or more types of phase change materials, which usually consist of organic-organic (Capric-lauric/Lauric palmitic/Myristic-stearic), inorganic-inorganic (LiOH-KOH/MgKCl₂-KCl/BACl₂-KCl-NaCl) and inorganic-organic (Naphthalenebenzoicacid/Urea NH₄Br) materials [28]. In eutectic materials, all components change synchronously into a liquid during the melting process and during the freezing process they form a crystal mixture. In general water-salt solution with a eutectic composition is used for energy storage for temperatures below 0 °C [8].

Organometallic SS-PCMs (solid-solid transition) are a group of layer perovskite organometallics. They have a crystalline structure in

which organic and inorganic layers alternate [4]. In study [4], the SS-PCM organometallic transition was found to be chemically stable at moderately high temperatures, completely reversible after 1000 thermal cycles, with a small volume change of 5–10% during the transition, and additionally it was found that in the presence of air exhibit slow decomposition at temperatures above 500 K.

4. Encapsulation of PCMs

Encapsulation is a method that prevents direct contact of the active substance PCM with the environment, thus reducing the risk of leaks. This prolongs its lifetime and reduces problems related to phase separation [29]. There are several ways to improve the performance of LHSTES PCMs [9].

There are several ways to improve the performance of PCM systems. The first one is to increase the heat transfer surface area, e.g. by encapsulating PCM or by means of finned tubes. The second is to add nano-additives, thus increasing thermal conductivity. The last method is to improve the uniformity of heat transfer and thermodynamic optimisation of PCM. The above methods impact both the heat transfer surface and the thermal conductivity. In most cases, except for some applications of water-ice, the PCM needs to be encapsulated to hold the liquid phase of the PCM and to avoid contact of the PCM with the environment, which might harm the environment or change the composition of the PCM. In some cases the encapsulation serves as a construction element (it adds mechanical stability) [8]. The PCM encapsulation with different geometries of capsules has its own advantages and disadvantages [26]. The encapsulation techniques can be divided into micro, macro and nanoencapsulation [8,22,30].

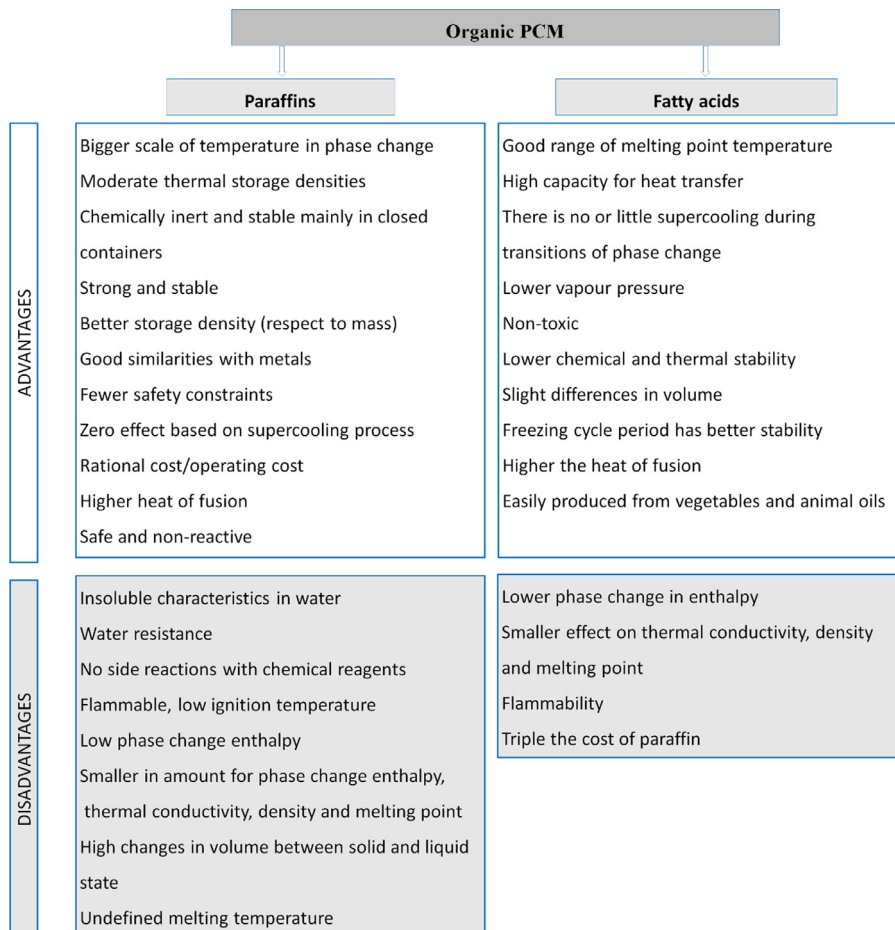

Fig. 8. Comparison of organic PCMs [22].

Encapsulation techniques													
	Encapsulation techniques												
	<table border="1"> <thead> <tr> <th>Macroencapsulation (1mm to >1 cm)</th> <th>Microencapsulation (1 μm to 1 mm)</th> <th>Nanoencapsulation (<1 μm)</th> </tr> </thead> <tbody> <tr> <td> APPLICATIONS Building envelope: Lower the building energy consumption and enhance thermal comfort. </td> <td> APPLICATIONS Food Industry: Extend the food product life. Beverage production. Transport drugs to the target site in the body. Textile Industry: Imparting finishes. Widely used in agricultural and environmental regions. </td> <td> APPLICATIONS Delivered drug delivery to the desired location as required. Products stability and life span extended, such as vitamin. Incorporated fragrances for aromatic clothing. </td> </tr> <tr> <td> DISADVANTAGES Low thermal conductivity or heat transfer features. Solidification at the boundaries. </td> <td> DISADVANTAGES Material strength may affect. Direct to super cooling properties. Expensive encapsulation technique. Natural convection is disturbed disturbing solidification occurrences. </td> <td> DISADVANTAGES Higher production cost. Further treatment required for purification. </td> </tr> <tr> <td> ADVANTAGES Enriched material compatibility with the environment. Exterior volume change properties are moderated. Handling of PCM also improved during manufacturing. May act as heat exchangers Preventing alterations of its composition via exposure to the surrounding. Lower production cost process. Mechanical strength of PCM increased due to the shell's usage. </td> <td> ADVANTAGES During the phase change, maintains reasonable volume control. Inclusion into conventional building materials with ease. Enhanced chemical strength. Extensive enhancement of thermal reliability. Act as a barrier and prevent leakage of PCM. </td> <td> ADVANTAGES API protection from degradation. Targeted drug transport with exterior coating. Modification to external charge can offer cell entry. </td> </tr> </tbody> </table>	Macroencapsulation (1mm to >1 cm)	Microencapsulation (1 μm to 1 mm)	Nanoencapsulation (<1 μm)	APPLICATIONS Building envelope: Lower the building energy consumption and enhance thermal comfort.	APPLICATIONS Food Industry: Extend the food product life. Beverage production. Transport drugs to the target site in the body. Textile Industry: Imparting finishes. Widely used in agricultural and environmental regions.	APPLICATIONS Delivered drug delivery to the desired location as required. Products stability and life span extended, such as vitamin. Incorporated fragrances for aromatic clothing.	DISADVANTAGES Low thermal conductivity or heat transfer features. Solidification at the boundaries.	DISADVANTAGES Material strength may affect. Direct to super cooling properties. Expensive encapsulation technique. Natural convection is disturbed disturbing solidification occurrences.	DISADVANTAGES Higher production cost. Further treatment required for purification.	ADVANTAGES Enriched material compatibility with the environment. Exterior volume change properties are moderated. Handling of PCM also improved during manufacturing. May act as heat exchangers Preventing alterations of its composition via exposure to the surrounding. Lower production cost process. Mechanical strength of PCM increased due to the shell's usage.	ADVANTAGES During the phase change, maintains reasonable volume control. Inclusion into conventional building materials with ease. Enhanced chemical strength. Extensive enhancement of thermal reliability. Act as a barrier and prevent leakage of PCM.	ADVANTAGES API protection from degradation. Targeted drug transport with exterior coating. Modification to external charge can offer cell entry.
Macroencapsulation (1mm to >1 cm)	Microencapsulation (1 μm to 1 mm)	Nanoencapsulation (<1 μm)											
APPLICATIONS Building envelope: Lower the building energy consumption and enhance thermal comfort.	APPLICATIONS Food Industry: Extend the food product life. Beverage production. Transport drugs to the target site in the body. Textile Industry: Imparting finishes. Widely used in agricultural and environmental regions.	APPLICATIONS Delivered drug delivery to the desired location as required. Products stability and life span extended, such as vitamin. Incorporated fragrances for aromatic clothing.											
DISADVANTAGES Low thermal conductivity or heat transfer features. Solidification at the boundaries.	DISADVANTAGES Material strength may affect. Direct to super cooling properties. Expensive encapsulation technique. Natural convection is disturbed disturbing solidification occurrences.	DISADVANTAGES Higher production cost. Further treatment required for purification.											
ADVANTAGES Enriched material compatibility with the environment. Exterior volume change properties are moderated. Handling of PCM also improved during manufacturing. May act as heat exchangers Preventing alterations of its composition via exposure to the surrounding. Lower production cost process. Mechanical strength of PCM increased due to the shell's usage.	ADVANTAGES During the phase change, maintains reasonable volume control. Inclusion into conventional building materials with ease. Enhanced chemical strength. Extensive enhancement of thermal reliability. Act as a barrier and prevent leakage of PCM.	ADVANTAGES API protection from degradation. Targeted drug transport with exterior coating. Modification to external charge can offer cell entry.											

Fig. 9. Encapsulation techniques applications and advantages/ disadvantages [22].

Different methods can be applied to accomplish microencapsulation: physico-mechanical method (spray drying, centrifugal extrusion, vibrational nozzle, solvent evaporation), chemical (suspension polymerisation, mini-emulsion polymerisation) or physico-chemical method (coacervation, ionic gelation) based on organic PCMs with physico-chemical applications [22]. Applications with advantages and disadvantages of encapsulation techniques are presented in Fig. 9.

4.1. Microencapsulated phase change materials

Microencapsulation is designed to optimise heat transfer of phase change materials by changing the surface to volume ratio. This makes

it suitable for use in building materials especially for passive storage of thermal energy. However, this is not their only application as they are perfectly suited for cooling and heating applications in buildings, textiles, heat transfer fluids and heat insulating foams and MPCM slurry [31,32]. Microencapsulation can take place both physically and chemically. The polyethylene microencapsulation technique is applied for the coating of medicines, probiotic bacteria in the pharmaceutical and food industries, or pesticides in the agricultural industry. Over a given period of time, it is possible to estimate the potential energy savings from the use of PCM in buildings compared to a solution without PCM. This can be expressed in percentage energy savings and percentage peak heat flux reduction according to the formulae below [12]:

$$\begin{aligned}
 & \% \text{ energy savings} \\
 &= \frac{\text{Energy consumption without PCM} - \text{Energy consumption with PCM}}{\text{Energy consumption without PCM}} \\
 & \times 100
 \end{aligned} \tag{14}$$

$$\begin{aligned}
 & \% \text{ peak heat flux reduction} \\
 &= \frac{\text{Maximum heat flux without PCM} - \text{Maximum heat flux with PCM}}{\text{Maximum heat flux without PCM}} \\
 & \times 100
 \end{aligned} \tag{15}$$

Microencapsulation is a technique involving the closure of unstable, sensitive solid or liquid particles with a diameter of 1 μm–1000 μm with a solid layer [8,30]. This protects the energy storage material by preventing degradation and evaporation processes and better solubility [22].

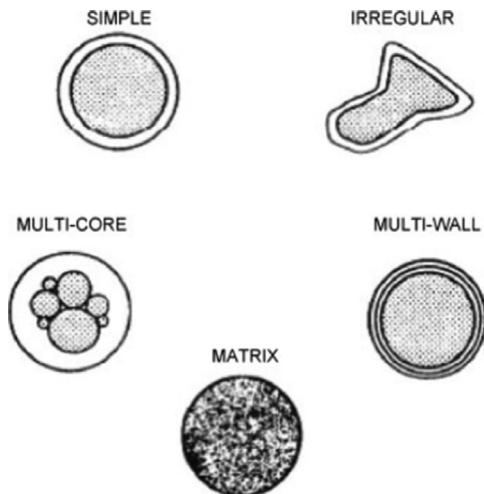

Fig. 10. Morphology of different types of microcapsules [33].

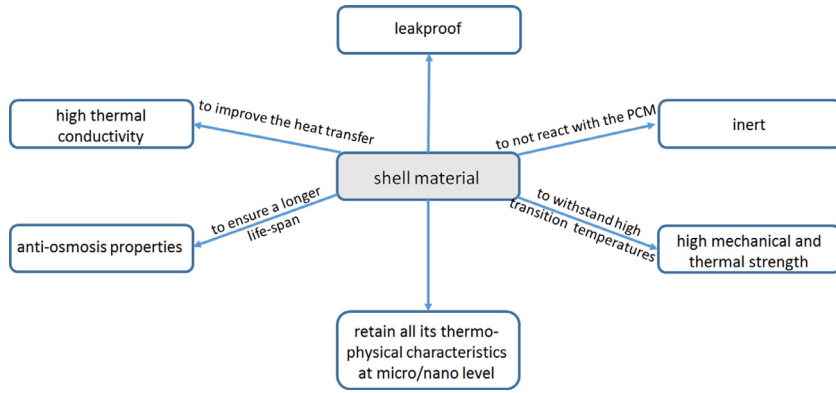

Fig. 11. Features of the MPCM shell [12].

Fig. 10 shows different types of micro-capsules from the simplest and most typical spherical particle form through particles with an irregular core, diverse cores within the same capsule, multi-walled microcapsules and particles embedded in a continuous matrix [33].

The efficiency of this synthesis process is the ratio of mass of micro-capsules with fully formed shells in the sample to the total mass of microcapsules in the sample [32]. The shell material determines the performance of MPCM. Fig. 11 shows the most important features of the shell [12]:

MPCM improves heat storage capacity. Selecting a material type for the MPCM shell, it is important to note that the thermal conductivity of an organic material is lower than that of an inorganic material. A wide range of preparation methods of MPCM has been discussed by Rathore et al. [12]. The authors indicate that metal and carbon-based materials in the shell additionally improve the thermal conductivity of MPCM.

Alva et al. [32] present a summary of the studies on synthesis, characterisation, properties and applications of MPCM for TES.

Rathore et al. [12] focused on assessing the potential of MPCM integrated directly into the building materials like mortar, brick, and cement, real-time testing with lightweight building material like wallboard, plasterboard and gypsum.

Fig. 12 present advantages and disadvantages of different micro-encapsulation methods of phase change materials widely discussed by the authors in the article [33].

4.2. Macroencapsulation of the PCM

It is investigated that microencapsulation is a process in which the PCM material is encapsulated in a shell substance of higher than 5 mm [10] or 1 mm [30]. It is indicated that the shell geometry of the encapsulation can be in the shape of cubes, pouches, cylinder, tubes or any other forms. This gives the opportunity to made macroencapsulation an ideal solution for PCMs to be used in building envelopes since it comes in different form, size and shape.

The structure and physical configuration of microencapsulation can be different when it comes to different TES devices such as shell and tube, packed bed and flat plates as shown in Fig. 13 [24].

4.3. Nanomaterial PCMs

Particle dimensions of nanomaterials range from 1 to 1000 nm [30]. For the production of nanomaterials, the methodology uses either a top-down or a bottom-up technique [22] as shown below:

Top-Down Technique: this approach involves the use of specific method to reduce the size and shape the required nanomaterial applications. The methods used for this technique are namely emulsification and emulsification solvent evaporation.

Bottom-up Technique: in this method, materials are formed by self-assembly of molecules determined by elements such as concentration, ion properties, temperature and pH. Techniques used are namely such as coacervation and nanoprecipitation. Integration complexity are also part of this strategy.

	Microencapsulation methods								
	Physical			Physical-chemical			Chemical		
FORMING PROCESS	Spray drying	Solvent evaporation	Simple coacervation	Complex coacervation	Sol-gel	Interfacial	Suspension polymerization	Emulsion polymerization	
ADVANTAGES	Low cost Easy to scale up	Low cost	Versatile Flexible operation	Efficient control of the particle size	Inorganic shell with high thermal	Versatile Mechanical resistance	Good heat control of the reaction	High molecular weight polymer	
DISADVANTAGES	Agglomeration of particles Remaining uncoated particles	Small production	Agglomeration	Agglomeration Difficult to scale-up	Still under research	Poor mechanical properties	Few monomers are water soluble	Purify polymer from the surfactant	
SHELF LIFE	Short	Medium	Short	Short	Medium	Short	Long	Long	
QUALITY (mechanical and thermal performances)	Poor	Poor	Poor	Poor	Good	Poor	Good	Good	
RELIABILITY	Poor	Poor	Poor	Poor	Good	Poor	Good	Good	

Fig. 12. Microencapsulation methods of phase change materials [33].

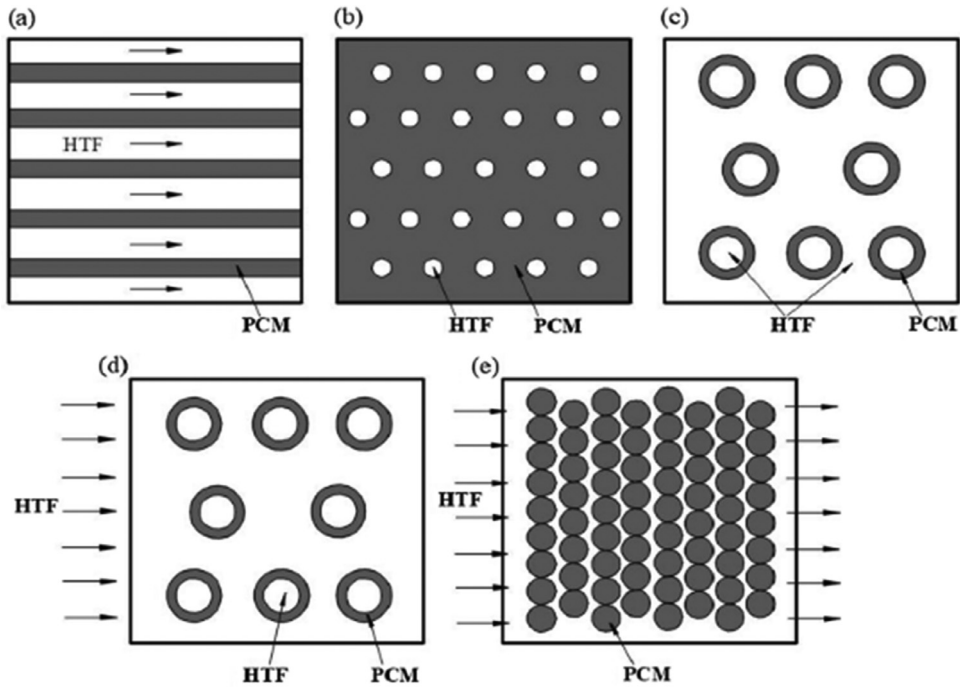

Fig. 13. Different types of thermal energy storage devices [24]: (a) Flat plate; (b) Shell and tube—internal flow; (c) Shell and tube—parallel flow; (d) Shell and tube—cross flow; (e) Packed bed.

Nanoparticle diffusion in PCM (also known as nanoPCM) is another process considered that can increase the thermal conductivity of PCMs [26]. For instance and as investigated by the authors in [34], paraffin was mixed with a type of nano-SiC that led to the increase of thermal conductivity of a PV/T panel. Other articles such as [29] discuss the practicality of other highly thermally conductive nanoparticles and draw a study around materials such as carbon

based fibres and nanotubes, aluminium and silver nanoparticles, and metallic passed foams.

There are several techniques for obtaining precise particle size, surface area and pore size distribution of carbon materials. Additionally, expanded graphite can be separated into very fine particles with a thickness of 10–100 nm, known as graphite nano-platelets (GNPs) or exfoliated graphite. As shown in Fig. 14 the graphene is classified as a pure graphite layer, which was actually derived from the breakage of the graphite crystal until a single layer of the element is created [13]. A nanotube in simple terms made of graphene sheet rolled into a cylindrical shape with edges knitted together, whereas a fullerene is produced by mating graphene segments to each other into a spherical shape. The described materials are discovered to each present a unique characteristics to graphite even with having the same atomic configuration as represented in Fig. 14.

Mahdi et al. [35] demonstrated that thermal transfer improvements through the material can be accomplished either specifically by inserting solid high thermal conductivity components such as metallic fins, foam and heat pipes in the material, or indirectly by enhancing the heat transfer-physical properties of the substance such as thermal conductivity, real heat and latent heat of the PCM itself using micro-and nano-additives. These additives can be in the form carbon nanotubes, metal nanoparticles or carbon nanofiber. Another example is the use of nano PCM for cooling of PV/T system that was constructed to increase the power output and enhance heat transfer from the panels [36].

5. Shape-stabilisation

Shape stabilisation is an important technique to avoid leakage and improve the energy storage ability of PCM materials [31,37–39]. Form-stabilised phase change material or in short SSPCM consists of a working material and a supporting component. The working material absorbs or removes latent heat during the melting or solidifying cycle, while the supporting substance stops the melting process from leaking of material so that the entire system stays in solid state [31]. A variety of materials are used to stabilise the form of PCMs, which primarily include porous materials, nanomaterials and polymers. an

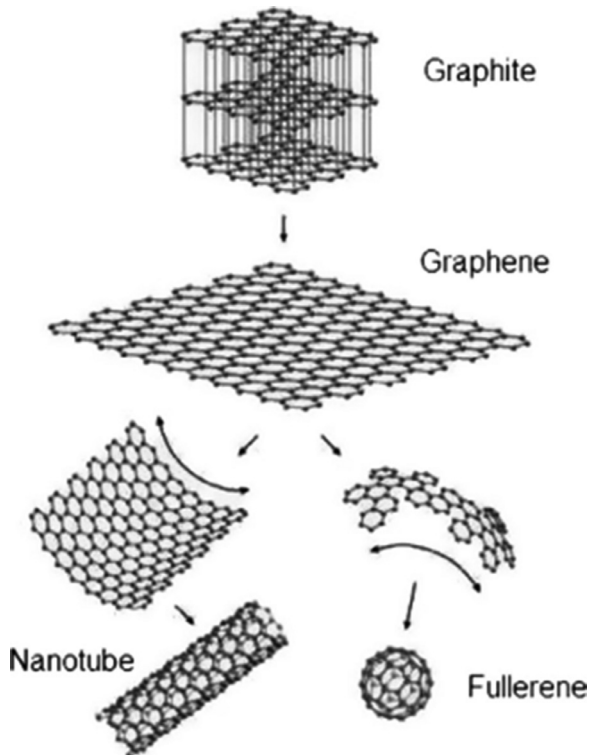

Fig. 14. Graphite and three comprising nanomaterials [13].

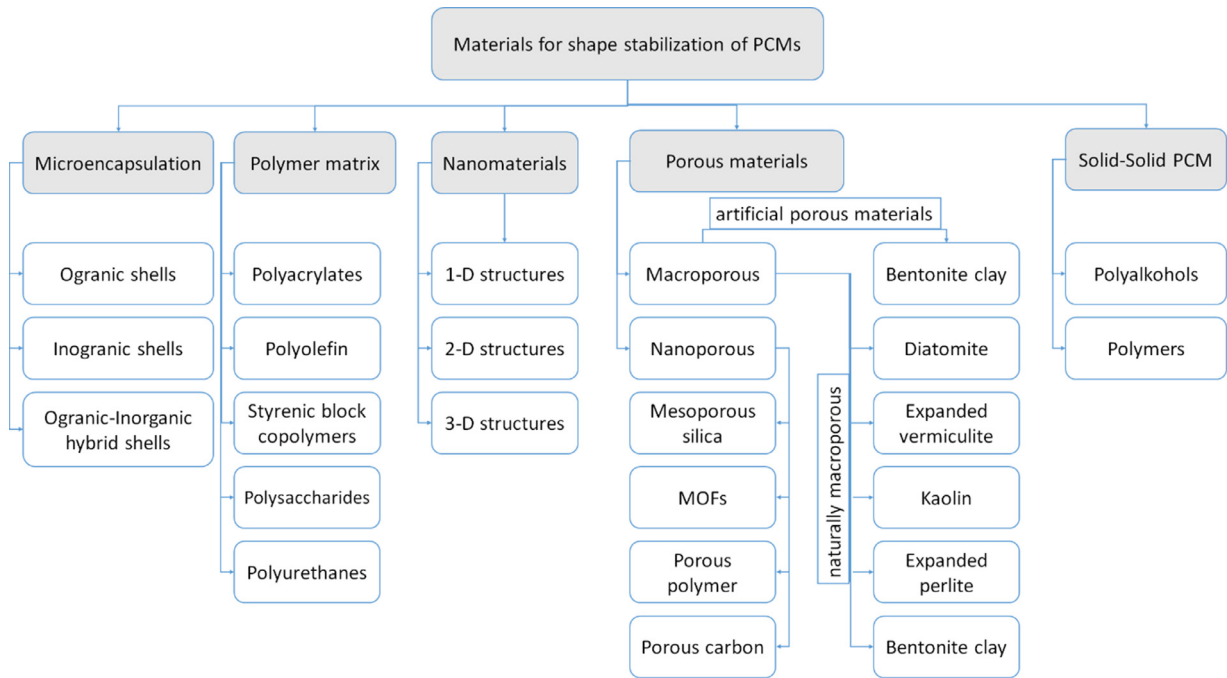

Fig. 15. Supporting materials used for shape stabilisation of PCMs [31,37].

outline of the mentioned supporting materials is shown in Fig. 15. Having said that, it should be noted that the addition of a supporting material eventually results in a reduction of density for energy storage [40].

It is discovered that nano-porous composite PCMs eliminate the leakage problems and display excellent chemical consistency and thermal cycling performance. Having said that, they are found to have the disadvantage of offering much lower values of enthalpy than pure PCM compositions [31]. Having said that, on the other hand and compared to microencapsulated phase change materials, porous on shape-stabilised PCMs are more open and their continuous porous support system is more desirable for improving the material thermal conductivity [37]. Depending on the pore size of the support, porous shape-stabilised PCMs can be divided into macro- and nano-porous shape-stabilised PCMs. In this regard, certain artificial porous materials, such as metal foam, as well as microporous materials, such as expanded vermiculite, diatomite, kaolin, expanded perlite and bentonite clay have been used

as porous material supports. Nevertheless, due to the poor interaction between PCMs and matrix macropores, these mentioned traditional porous materials cannot effectively solve the problem of leakage under large loaded amounts of PCMs [37].

Specifically, two main methods are used for the enclosure of solid or liquid PCMs to create shape-stabilised PCM composites, as presented in Fig. 16 [37]. The introduced approaches made are commonly described as a one-step in-situ synthesis process and a two-step impregnation method. The two-step method includes impregnating liquid PCMs in a nanopores support that is pre-synthesised. It has been noted that considerable effort has been made to establish proper porous support, as it is investigated that, the surface property, the pore size and the structure of the support could indicate a major impact on thermal properties of the composite PCMs. It is discovered that in the one-step process, PCMs are encapsulated in place during the creation of an integrated porous support network.

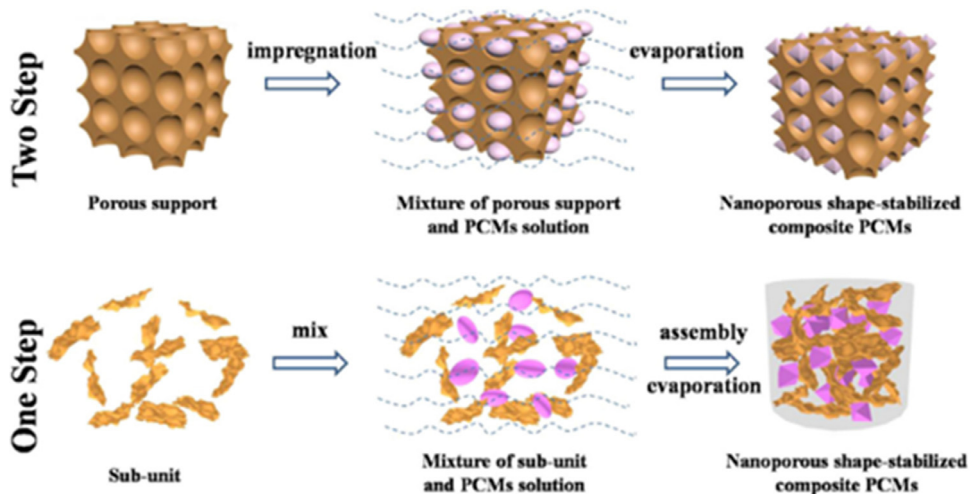

Fig. 16. Two-step and one-step preparation process [37].

Recent use of nano-porous shape-stabilised composite PCMs such as electro-to-heat, light-to-thermal, magnetic-to-thermal conversion, tumour thermo-chemotherapy and electronic thermal control, have been addressed [37]. The studies stated that the pore size, structure and surface property significantly affect the storage and utilisation capacity of nano porous shape stabilised composite PCMs. It is discovered that compared with microencapsulation, shape-stabilisation of organic PCMs with that is created with the help of polymer matrix is an simple and more cost-effective method [31].

Organic molecules that are capable of reorganising supramolecular interactions, can theoretically experience highly exothermic solid-solid phase transitions based on temperature. These are indicated to be made of extremely symmetrical and voluminous alcohols namely as neopentyl glycol (NPG), pentaerythritol (PE), trimethylol propane (TMP), and pentaglycine (PG) [4].

Umair et al. [31] offers a detailed description of the different groups of novel stabilising strategies including organic, inorganic and polymeric materials. the conducted study also demonstrates an appropriate critical study of the thermophysical properties of PCM materials. Yu et al. [23] examined an outer layer phase change material (RSPCM) roof in a residential construction integrating shape-stabilised PCM into the outer shell of the roof. Qu et al. [38] conducted an experiment into the functionality of HDPE SS-PCM using two forms of fillers to produce advanced paraffin-based SS-PCMs. In another study, K₂CO₃-Na₂CO₃ carbonate and MgO were used to synthesise PCMs by employing glass powder as a joining agent and to avoid dusting [39]. This shape stabilising PCM offer good and practical thermal energy storage and functional physical performance. A new type of shape-stabilised PCM (SSPCM) that was made of paraffin wax and expanded graphite composite material was added to the solar application [41]. In this study, an experiment was carried out to demonstrate the viability of the SSPCM used in the solar system, based on which, the proposed theoretical model was verified. Based on this, the results showed that daily performance increased from 42% to 53% relative to solar systems with no cooling while the thermal conductivity of SSPCM went up from 0.2 to 4.0 W/m K. The production from the system increased by nearly 35% as the melting temperature of SSPCM raised from 34 °C to 50 °C.

6. Cascaded latent heat TES system

The charging rate of the PCM material can be significantly be enhanced with the increase in heat transfer. Nevertheless, it should be noted that the PCM thermal storage unit always offer an efficiency limit [42]. It is discover that the latent heat TES systems or namely LHTESS offers an acceptable charging and discharging volume since it is comprised of multiple PCM systems [43]. For instance, the benefits of using multiple PCM systems at different temperature range has been theoretically studied [44]. Analytical studies are mainly conducted to investigate and discover the performance of optimal PCM temperature and heat transfer fluid on the basis of entropy principles. Fig. 17 indicates the distinction between single-stage thermal storage systems (a) and five-stage thermal storage systems (b). It is discovered that the five-stage system has a much broader operating temperature range and more uniform temperature variations between the phase change material and the working medium when compared to the single stage system [44]. Xu and Zhao [45] reported thermal efficiency and performance of a cascaded thermal storage that incorporated unstable inlet HTF. In the investigation, the improvement of temperature of PCM and HTF was conducted based on entropy, entransy and exergy analyses.

Having indicated that is discovered the Cascaded Latent Heat TES (CLHTES) systems are highly difficult to develop in order to deliver the maximum energy storage capacity and exergy performance. This therefore means that a thorough analysis heat transfer of the thermal storage system is required when considering the utilisation of such a system [46].

According to Khor et al. [47], in order to achieve a high-level volumetric capacity a cascaded latent heat TES system should be optimised using PCM materials in a packed bed form. Stating that cascading PCMs of variable temperatures will ensure constant heat flux due to the relative difference in temperature to that of the heat transfer fluid and the material along the direction of the flow.

In alternative studies, Prasad et al. [43] developed a numerical model to analyse the effective heat capacity method, investigating melting and solidification within a shell and tube cascade TES systems. Whilst Xu et al. [42] investigated heat transfer of a solar thermal cascaded storage system capable of accommodating multiple PCM systems.

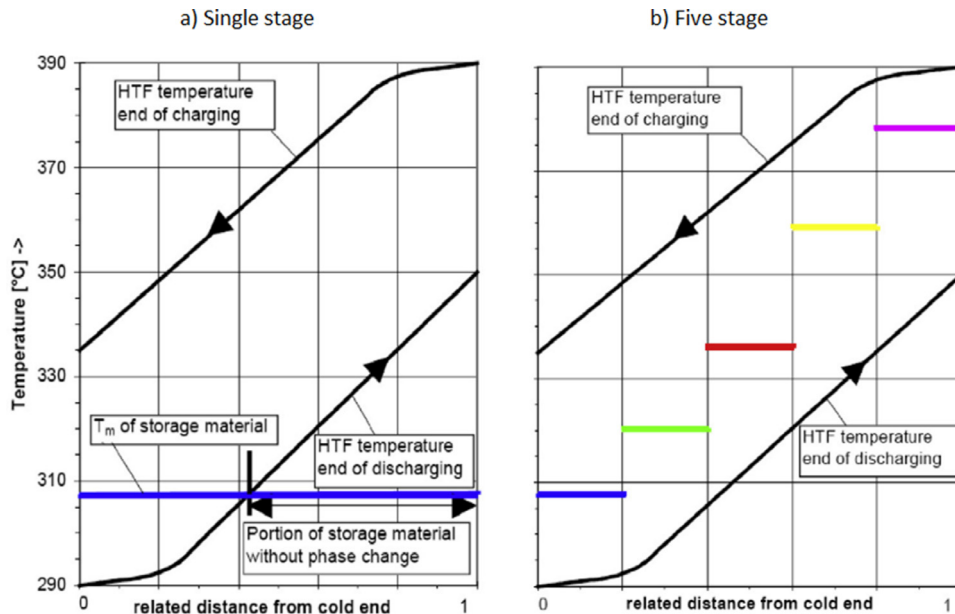

Fig. 17. Comparison between (a) systems of the single-stage thermal storage and (b) the five-stage thermal storage [44].

TES systems accepting multiple PCMs, including both cascaded or multistage models, where the focus of Tehrani et al. [48], who initiated an investigation into a total of twelve cascaded groups and eleven single medium designs, with 45 design alternatives over-all. The systems are grouped to enhance heat transfer performance with relevance to solar power plants. These accounted for a range of PCM systems with varying melting points specific heat capacities, and latent heat of fusion.

When conducting simulation in relation to the use of cascading PCMs, Tessier et al. [49] used a method of staged temperature change. Through the use of PCM material, air was cooled and heated indicating decreased difference in the temperature of the thermal energy storage material and air. The results showed a reduction in quantity of entropy produced by heat exchange processes. Through the reduction of the produced entropy, the quantity of unused energy was increased, ensuing an improved overall system efficiency.

With direct relevance to the development and optimisation of a model to predict fluid and PCM temperature, Shamsi et al. in [50], concentrated on the use of cascade latent heat storage system to investigate the application and characteristics of genetic algorithm techniques and verifying that against experimental data.

7. Temperatures range

PCM are developed in accordance to the working temperature of the material used. The working temperature of PCMs are mainly categorised into 4 different ranges [9], mainly as:

- High temperature (+80 °C to +200 °C or above);
- Medium temperature (+40 °C to +80 °C);
- Low temperature (+5 °C to +40 °C).

The high temperature application includes the use of PCM for waste heat recovery and absorption cooling, whereas, the medium range PCMs are used for solar and electronic thermal management systems. On the other hand, the low range temperature PCMs are utilised for thermal cooling and heating applications and use in buildings. Having indicated that, the generally used materials based on different temperature range and types are indicated in Table 4 [9].

Table 5 indicates the PCM materials that can be used in buildings to improve energy efficiency. It is discovered that the choice of PCM depends on the nature of the application that the material would be used for. For instance, systems such as indoor HVAC need low-temperature storage, on the other hand, power generation systems require higher range of energy storage systems. Many studies have researched the use of PCM in buildings for efficiency improvements and energy savings. Having said that, it is discovered that there is yet a PCM to be developed that can be consistent with all building functional conditions [10].

Table 6 displays the various PCM applications according to the specific temperature scale. Thermal characteristics of various forms of solid-liquid or SL-PCMs and solid-solid or SS-PCMs can be seen in Fig. 18.

Gasia et al. [51] conducted a study on possible high-temperature thermal storage systems of around > 150 °C applications including their markets and range of working temperatures. Moreover, the

Table 4
Commonly used materials for sensible heat storage in buildings.

Material	Type	Temperature range (°C)	Density(ρ in kg/m ³)	Specific heat(kJ/kg K)	Thermal conductivity(W/m K)
Cement mortar	Solid		1800	1	1
Limestone	Solid		1600–2600	1	0.85–23
Water	Liquid	0–100	1000	4.19	0.608
Steel	Solid	20–70	7800	0.502	163–18
Reinforced concrete	Solid	20–70	2500	1020	–
Granite	Solid	20–70	2650	0.900	1.73–3.98
Plain concrete	Solid	–	2100	1020	0.92
Brick	Solid	20–70	1600	0.84	0.15–0.6
Wood	Solid	–	800	2.093	0.04–0.17
Gypsum board	Solid	–	750	1060	0.17
Sandstone	Solid	Up to 160	2200	0.71	2327
Granite stone	Solid	Up to 160	2640	0.82	2.12–112
Glass	Solid	–	2710	827	0.8–1.4
Iron	Solid	Up to 160	7900	452	803
Fibre board	Solid	–	300	1	0.3
Aluminium	Solid	Up to 160	2707	0.896	237
Oil	Liquid	–	888	1.88	0.14
Clay or Silt	Solid	–	1200–1800	1.2–2.65	1.5
Cement mortar	Solid		1800	1	1
Limestone	Solid		1600–2600	1	0.85–23
Asphalt sheet	Solid	–	2300	1.7	1.2
Asphalt sheet	Solid	–	2300	1.7	1.2
Clay or Silt	Solid	–	1200–1800	1.2–2.65	1.5
Fibre board	Solid	–	300	1	0.3
Glass	Solid	–	2710	827	0.8–1.4
Gypsum board	Solid	–	750	1060	0.17
Oil	Liquid	–	888	1.88	0.14
Plain concrete	Solid	–	2100	1020	0.92
Wood	Solid	–	800	2.093	0.04–0.17
Water	Liquid	0–100	1000	4.19	0.608
Brick	Solid	20–70	1600	0.84	0.15–0.6
Granite	Solid	20–70	2650	0.900	1.73–3.98
Reinforced concrete	Solid	20–70	2500	1020	–
Steel	Solid	20–70	7800	0.502	163–18
Aluminium	Solid	Up to 160	2707	0.896	237
Granite stone	Solid	Up to 160	2640	0.82	2.12–112
Iron	Solid	Up to 160	7900	452	803
Sandstone	Solid	Up to 160	2200	0.71	2327

Table 5

The shows the types of PCMs that can be used for building [10].

PCM	Type	Thermal Conductivity (W/m K)	Melting Temperature (°C)	Heat of fusion (kJ/kg)
Palm wax/Diatomite	Organic	–	50.5–62.4	44.29
Lauric add (40–80 wt%)/Asphalt (60–20 wt%)	Organic	–	31.81–38.65	50.14–128.1
CaCl ₂ ·6H ₂ O–8 vrt% Mg(NO ₃) ₂ ·6H ₂ O/EC	Eutectics	5.5	21.17–27.87	105.4
Dodecanol/diatomite		0.15	23.3–29.5	75.8
CaCl ₂ ·6H ₂ O–MgCl ₂ ·6H ₂ O(10–25 wt%)	Inorganic	0.732	20.2–24.5	130.3–162.1
Paraffin (RT27)/hydrophobic expanded Perlite/Graphene nanoplatelets	Organic	0.5	24.50–26.95	79.35
Silica fume/Capric acid–Palmitic acid/CNT (1–5 wt%)	Eutectics	0.35–0.47	22.78–24.18	48.19–46.21
Methyl cinnamate/Cu–TiO ₂ (0.05–0.5 wt%)	Organic	0.212–0.323	35.59–35.45	108.2–1013
Palm oil/xGNP	Organic	1.268	18.33	77.18
KP4H ₂ O	Inorganic	–	18.5	231
n–Hexadecane	Organic	0.668	18.65	232.41
Xylitol pentapalmitate	Organic	–	18.75	170.05
Butyl stearate	Organic	–	19	140
Capric acid/palmitic acid/stearic acid/Nano–SiO ₂	Eutectics	0.082	21.86	99.43
Capric acid (75 wt%)/myristic acid (25 wt%)	Eutectics	–	22.17	153.19
n–Heptadecane	Organic	0.39	22.32	228.89
Dodecanol	Organic	–	23.44	205.88
Capric acid/Steric acid/white carbn black	Eutectics	0.38	24.89	78.74
Na ₂ SO ₄ ·10H ₂ O–Na ₂ CO ₃ ·10H ₂ O salt hydrate	Inorganic	–	25.41	1953
Mn(NO ₃) ₂ ·6H ₂ O	Inorganic	–	25.8	125.9
lactic acid	Organic	–	26	184
Hydrogenated palm kernel vegetable fat	Organic	0.2	26.53	7435
Coconut oil/xGNP	Organic	1.33	26.93	8234
n–octadecane/Diatomite with carbon nanoparticle	Organic	0.73	27.21	1343
Na ₂ CO ₃ ·10H ₂ O to Na ₂ HPO ₄ ·12H ₂ O (40:60)	Eutectics	–	27.3	220.2
Paraffin/expanded perlite	Organic	–	27.6	67.13
n–Octadecane	Organic	0.26	28	256.5
Lauric acid–myristic acid–stearic acid/Al ₂ O ₃ /Expanded vermiculite	Eutectics	0.671	28.6	113.17
LiNO ₃ · 3H ₂ O	Inorganic	–	30	189
Xylitol pentastearate	Organic	–	32.35	205.65
PEG1000 (45 wt%)/HNTOAg–3	Organic	0.9	33.6	713
PEG1000 (45 wt%)/HNT6 ¹ Ag–1	Organic	0.73	35.2	72.5
CaCl ₂ ·6H ₂ O – SrCl ₂ ·6H ₂ O/Graphene oxide	Inorganic	–	35.2	207.9–206.44
Neopentylglycol/Cuo(0.1 wt%)	Organic	–	40.22	104
Pure paraffin	Organic	0.356	54.38	142.72
polyethylene glycol/expanded perlite composite	Organic	0.47	55.19	134.93

study identified the different limits that TES materials and products should meet. This was done by conducting a literature review on optimum physical, chemical, thermal, economical, environmental, and technological efficiency. Li et al. [24] reviewed the numerous heat transfer and performance enhancement strategies with a

emphasis on the functionality and application of the techniques used for shell and tube systems comprising molten salt based PCMs for medium and high temperature range of 200–1000 °C. Mohen et al. [52] performed an investigation on experimental work of gas to gas, solid to gas and Sulphur-based thermochemical energy storage technologies operating at above 300 °C. the studied technologies are identified to be ideal for high-temperature solar-thermal applications

Table 6

Sector and applications relative to range of temperature [4].

Sector and Application	Range of temperatures	
	Minimum	Maximum
Cold production	–40 °C	–10 °C
Chips thermal protection	85 °C	120 °C
Desalination	40 °C	120 °C
Food thermal protection	–30 °C	121 °C
Thermal protection	–269 °C	130 °C
Spacecraft electronics protection	–269 °C	130 °C
Solar energy storage	20 °C	150 °C
Industrial waste heat recovery	30 °C	1600 °C
Biomedical applications	–30 °C	22 °C
Absorption refrigeration	80 °C	230 °C
Solar cooling	60 °C	250 °C
Industry	60 °C	260 °C
Space heating and cooling of buildings	18 °C	28 °C
Floating and cooling	–40 °C	350 °C
Adsorption refrigeration	–60 °C	350 °C
Electronic devices thermal protection	25 °C	45 °C
Solar clergy	20 °C	565 °C
Solar power plants	250 °C	565 °C
Cabin heating and refrigeration	–50 °C	70 °C
Heating and cooling of water	29 °C	80 °C
Battery and electronic protection	30 °C	80 °C
Transportation	–50 °C	800 °C
Exhaust heat recovery	55 °C	800 °C

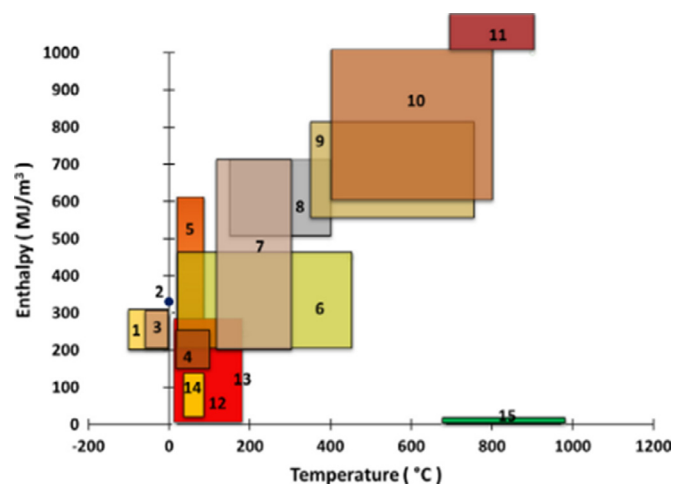

Fig. 18. Enthalpy and temperature ranges for SL-PCMs and SS-PCMs; L-PCMs; (1) Water-salt solutions; (2) Water; (3) Clathrates; (4) Paraffin; (5) Salt hydrates; (6) Sugar alcohols; (7) Nitrates; (8) Hydroxides; (9) Chlorides; (10) Carbonates; (11) Fluorides; (12) Polymeric; (13) Organics (Polyols); (14) Organometallics; (15) Inorganics (Metals) [4].

such as concentrating solar power plants. In addition to this, the conducted research also comprehensively analysed the selection thermal energy storage in materials that can stay stable above 600 °C for concentrated solar power (CSP) systems.

8. TES applications

8.1. PCM in building applications

The aim of this section is to present PCM materials and their selected properties together with the possibility of their application in buildings. The literature review indicates a number of directions that the researchers are following. The first of them is the analysis of new materials and combinations of existing PCM materials in building applications such as V. Ram et al in [55], which studies pumpable cement concrete with nanomaterials embedded phase change material (PCN-PCM). The second direction is the analysis in real conditions or in simulations software of known PCM materials but e.g. in new climatic conditions [54,56], or, as in the case of PCM layer, the

analysis of its best location and its thickness in the analysed material [53,54,60]. The last direction is a simulation analysis of the building as a whole or its elements with PCM materials [61]. With regard to the literature review that has been carried out, the conclusion is that there is no single optimal range for melting temperature. The choice of material depends on many factors, including: climate, season, location in relation to the sides of the world, location in the partition (closer to the inner or outer surface of the external wall). Table 7 gives an example of PCM types with temperature range and their application in buildings.

The use of the technology for building therefore means that overheating in hot seasons of the year can be avoided while in colder seasons, the building envelope temperature can be raised to acceptable levels. Fig. 19 demonstrates different types of PCM applications in buildings [65].

The use of phase change material combined with thermal storage systems can result in vast energy consumption reduction and helps to better control the temperature of the environment. The thermal storage technologies used in buildings can be either passive or active

Table 7
Example of PCM and their application in buildings.

Name	Type of PCM	Property	Applications
SavE® OM37 PCM	inorganic chemical-based PCM; (macro-encapsulated (tubular shape aluminium alloy 8011 containers))	Melting temperature range 35–40 (°C) Latent heat 218(J/kg) Density at 40 °C: 860(kg/m ³) Density at 30 °C: 960(kg/m ³) Thermal conductivity at 40 °C: 0.13(W/mK) Thermal conductivity at 30 °C: 0.16 (W/mK) Thermal stability ~3000(Cycles)	[55] walls, roof;
PCM RT44HC (RUBITHERM) DuPont™ Energain®	Organic paraffin-based PCM	Phase change temperature 40 °C–44 (°C) Thermal storage capacity 250 (kJ/kg) Phase change temperature 18 °C–24 (°C) Thermal storage capacity of (72 kJ/kg)	[56] Panels; (PCM encapsulated into aluminium panel); composite wallboards panel for interior cladding
P56–58 (MERCK)	Paraffin wax	Melting point range 42–72 °C Thermal conductivity 0.25 (W/mK) Density 900 (kg/m ³) Solidification point 56–58 (°C) Latent heat 250(J/kg)	[57] PCM integrated into the building wall
RT category (RUBITHERM)	organic materials	Melting temperature range –10–40 (°C) (1 °C intervals) Thermal conductivity 0.2 (W/mK) Density 880 (solid)/760 (liquid) (kg/m ³) Thermal storage capacity 250 (kJ/kg) layer thickness from 1 to 20mm	[58] PCM layer - external building wall (two different locations of PCM in the base wall)
concrete based-CPCM	LA-SA/Al2O3/C (Sinopharm Chemical Reagent Co.,Ltd)	Melting temperature range 22.5 (°C) Latent heat 133.4 (kJ/kg)	[59] Building envelope
PCM (Paraffin n-heptadecane (C17H36))	Nano- encapsulated PCM wallboard shape-stabilised PCMs	Peak melting temperature 21.4 (°C) Latent heat 26.2 (kJ/kg) Peak melting temperature 21.7 (°C) Latent heat > 70.1 (kJ/kg)	[60] Building envelope (assess the capability of different simulation programs to model the PCMs in building envelop)
Calcium chloride Hexahydrate	inorganic salts	Melting temperature 30 (°C) Thermal conductivity 0.538 (W/mK) Density 1760 (solid)/ 1910 (liquid) (kg/m ³) Latent heat 187.8 (kJ/kg)	[54] concrete block
DuPont™ PCM	from EnergyPlus simulation program	Melting peak temperature: 18,20,22,24,26,28,30 (°C) Conductivity 0.6 W/mK density 1500 kg/m ³	[62] Passive PCM wallboards (building in Shanghai)
PCM	from EnergyPlus simulation program	Phase change temperature range of 4 (°C) for temperature spectrum between 19 (°C) and 27 (°C) Latent heat of 219 (kJ/kg) Thermal conductivity 0.2 (W/mK) Thickness 0.01 (m)	[63] inner layer of the building envelope (building in subarctic climate)
PCM	Inorganic salt hydrate (ANSYS Fluent)	Melting temperature 25.85 (°C) Thickness 0.025 (m)	[64] PCM layer –roof

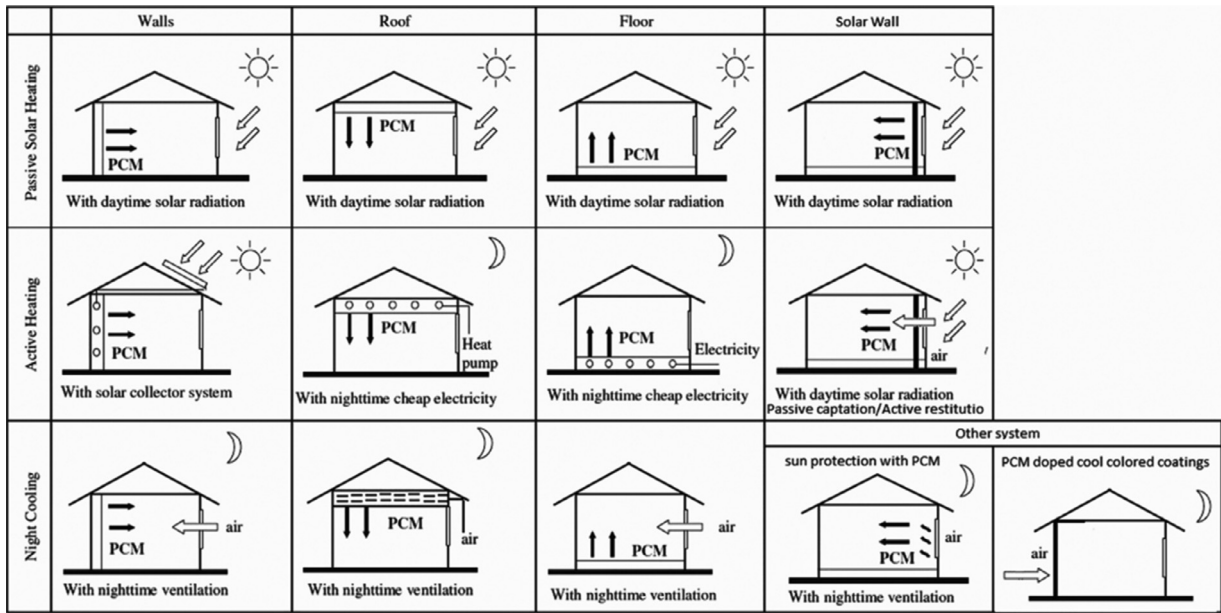

Fig. 19. Forms and effects of PCM applications in buildings [7].

and used mainly to store or release heat from a building envelope within the comfort temperature range of 15 °C–30 °C [66]. The use of PCM materials are discovered to be ideal both for new buildings and for the refurbishment of existing buildings [67]. For instance, PCM based thermal storage systems can be used for cooling, heating or both cooling and heating of buildings [68].

It is discovered that the melting range of PCM depends mainly on the placement of the material in the zone, the desired cooling set point and the type of application used. A research study conducted by Suayfane et al. [69], demonstrated that the cooling demand in the building sector has increased dramatically due to: a high requirement for occupants' comfort, a rise in buildings internal heat gains, more prevalent use of glass as a building façade material, the impact of urban heat island experienced in overcrowded cities, and the reduced cost of cooling equipment. Thus, integrating PCMs into buildings can decrease the HVAC related energy consumption and cooling cost as well as improving the thermal comfort of the occupants during hot seasons.

The idea of solar chimney demonstrates a successful strategy for the implementation of an efficient PCM for the cooling of buildings. A numerical analysis by Li et al. [70] examined the thermal efficiency of a PCM-based solar chimney as shown in Fig. 20, and discovered favourable results for PCM. The research has applied a parametric approach to investigate the influence of air flow, melting time and difference in ambient air temperature.

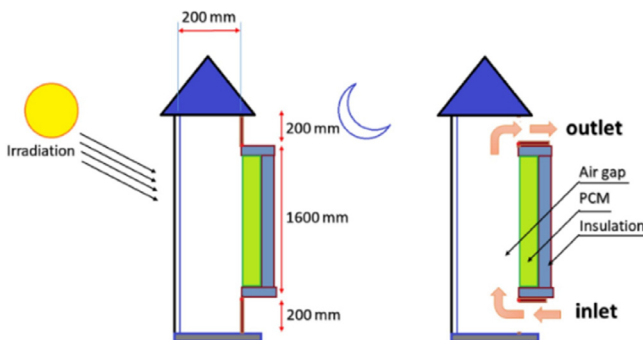

Fig. 20. Day and night operation of solar chimney integrated with PCM [70].

Lee et al. [71] conducted experiments on two similar prototype of rooms that were placed to meet different solar radiation conditions. The purpose of the research was to discover the thermal efficiency of PCM-enhanced cellulose insulation mounted in the cavities shown in Fig. 21. In this regard, cellulose material was combined with a paraffin-based PCM and results indicated that no adverse effect is observed on the PCM latent heat. The findings showed that peak heat fluxes were delayed by around 1.5 h on average, the hourly peak heat flux was reduced by 26.6% from the total of all four walls, and the average operating cost was reduced by 3 cents/m². Having indicated that, it was discovered that the west-facing wall is the only section that provides peak heat flux reduction by a large margin.

The variations among buildings using the traditional HVAC systems and the thermally activated buildings with PCM incorporated in its structure have been shown in Fig. 22 [72]. The figure demonstrates how thermally activated building structures (TABS) incorporated with PCM technology is capable of reducing the internal temperature variations and therefore maintaining thermal comfort within the building envelope.

The use of thermal storage can be implemented in new and retrofitted buildings, as this could be an attractive and flexible solution, such as incorporating RES in the HVAC for enhancing the efficiency of existing installations, space heating or cooling and potential implementation of peak load-shifting strategies [73].

The installation of TES in buildings can be carried out in a variety of structures, such as centre, base, walls, external solar facades, ceilings, ventilation systems, PV and water storage systems. One of the key functions of thermal energy storage in active building systems is the use of available cooling when storage is charged at low outdoor temperatures. This way, when cooling is necessary, this stored cold is discharged [74].

In addition, buildings integrated with thermal storage and solar systems are found to be capable of transforming intermittent energy sources and meet the requirements of heating and domestic hot water. The most common solar thermal storage system has been applied to incorporate solar air collectors into building walls or to use PCM in ventilated controlled facades as shown in Fig. 23 [75].

A variety of applications have recently become involved in Cool Thermal Energy Storage or CTES for refrigeration applications, including food storage, process cooling and air conditioning systems. Phase change materials offer desirable thermal properties that are ideal for

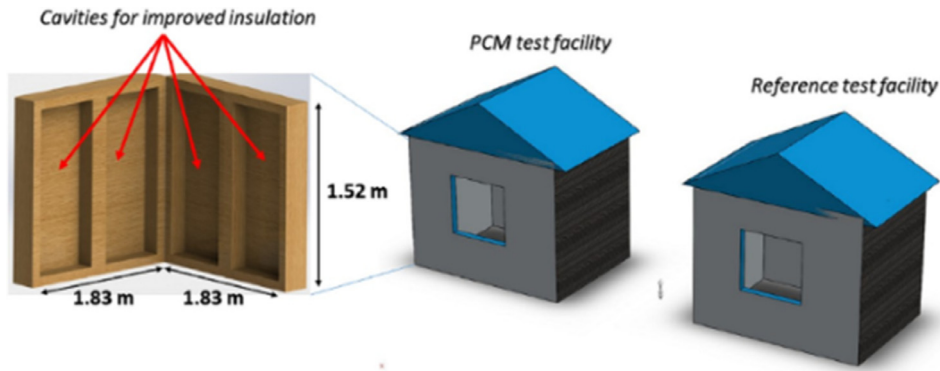

Fig. 21. Tested facilities for PCM adaptation [71].

air conditioning applications [76]. It is discovered that for air-conditioning and refrigeration applications temperatures of around -5 to 15 °C are ideal for thermal storage [77–79], but at lower temperatures, phase change based heat storage materials are better than reactive substances such as water.

Active and passive cooling differs in the fact that for active method, the use of a mechanical device such as a fan or a pump is required whereas for passive cooling not energy input to the system is used and the cooling is achieved mainly through natural conduction, radiation or convection [66].

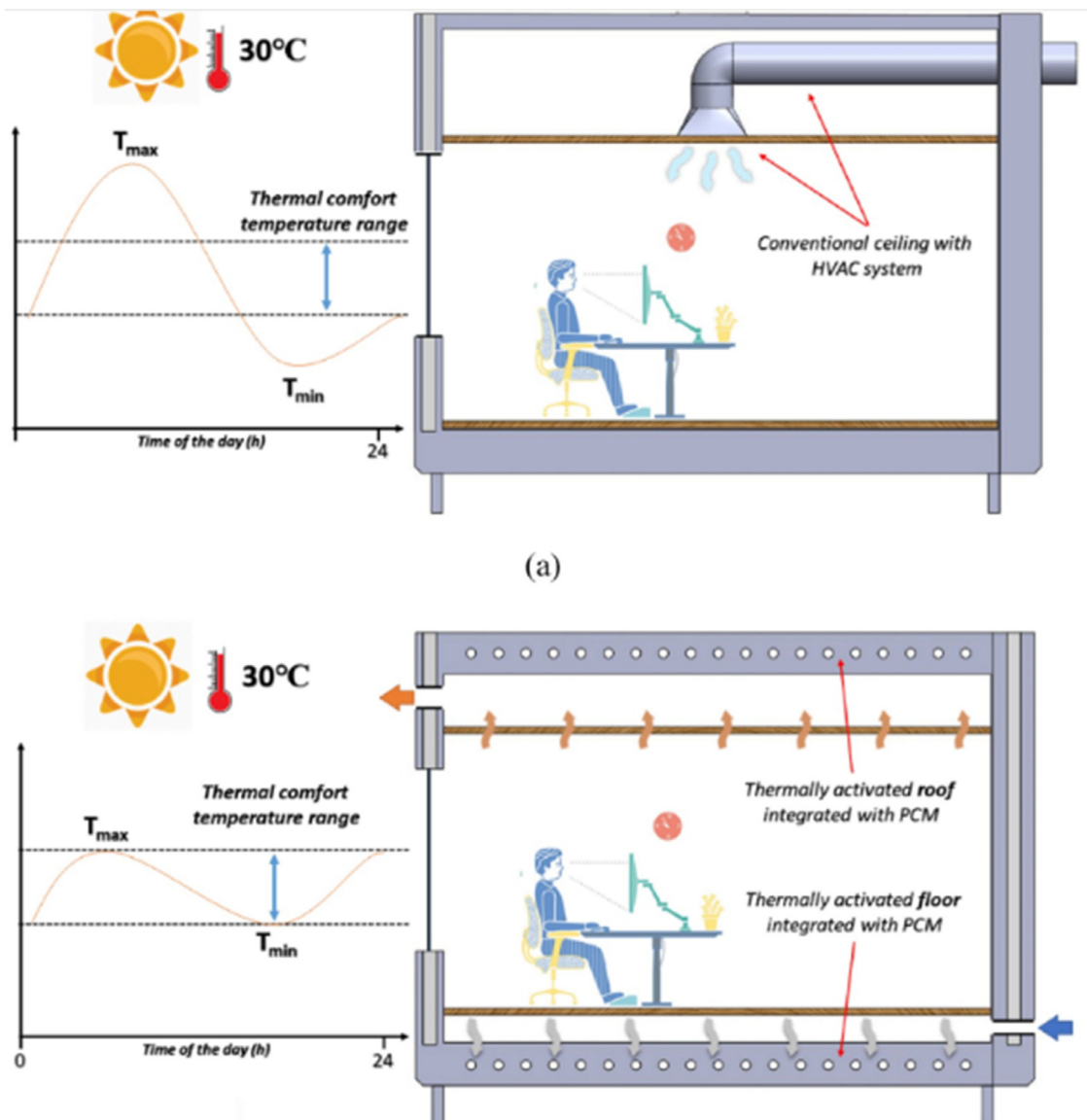

Fig. 22. Schematic showing the difference between (a) conventional HVAC cooled office and (b) an office integrated with TABS and PCM.

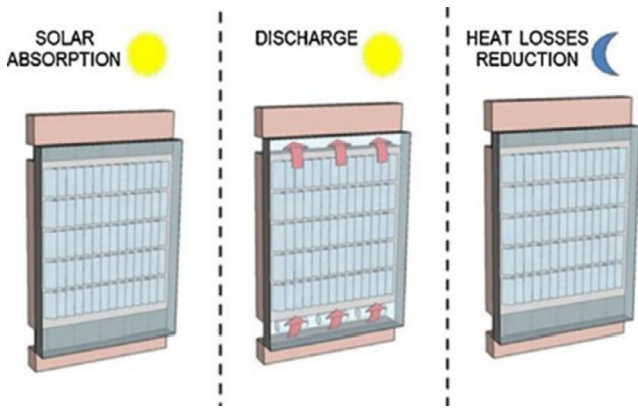

Fig. 23. Operational mode of the ventilated facade with PCM [75].

For instance, by placing PCMs at the back of PV panels cooling of the cells can be achieved entirely passively and thanks to the latent heat storage capacity of PCMs. Having indicated that, several energy balance analyses demonstrated that in order to achieve better performance, the use of higher energy density PCMs are an important factor. Nevertheless, maintain an optimal thermal contact between PV panel and PCM material is also indicated to be a key feature when designing such a system. Several regulations have also backed up the significance of the mentioned matters when coming into developing PV-PCM systems [80]. Fig. 24 discovers the selection of criteria of PCM for PV integrated systems.

Li et al. [28] performed simulation and experimental research and discussed the techniques employed on the optical and thermal performance of PCM integrated glazing units. Rahimi et al. [81] carried out an experimental investigation on a latent heat thermal energy storage system. It examines a shell and helical tube heat exchanger experimentally. Moreover, thermodynamic optimisation using exergy analysis is investigated meticulously for the proposed heat exchanger.

Arun et al. [82] performed an experimental investigation on a double-pass solar flat plate collector (DPSEPC) that is combined with latent heat thermal energy storage or LHTEs. The aims of conducting the analyses were to discover the thermodynamic performance and other aspects such as charging and discharging characteristics of paraffin wax inside the macro capsules with the DPSFPC containing air-flow channels.

8.2. Applications in power generation

It is discovered that approximately 47% of existing concentrating solar power plants use molten salt storage to produce electricity [18].

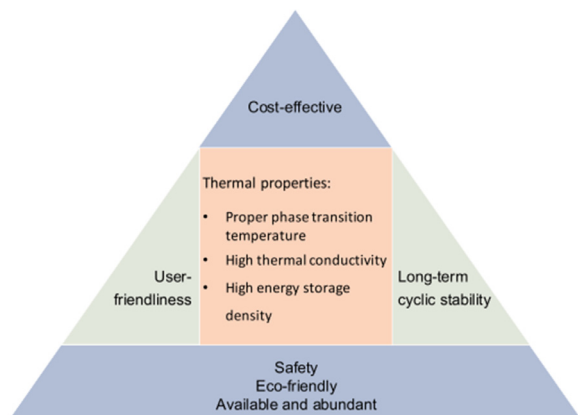

Fig. 24. Selection criteria of PCMs in PV systems [80].

Having said that, the key issue related with molten salt system are the requirement of high-volume storage, costly and very expensive heat exchangers, and the need for heavy installation facilities. Having indicated that, axillary heaters may also be required to prevent the freezing molten salts in the heat transfer loop.

Li et al. [24] investigated the advancements of molten salt integrated PCMs and discovered that the technology can provide promising results for concentrated solar plants that operate in the medium to high temperature of between 200 °C and 1000 °C range. Fig. 25 indicates the method of installation of a concentrated solar power plant with a molten salt based thermal storage system technology.

The conclusion from the experiment illustrated a configuration that comprised the top 25% area of the system with a molten salt with high temperature capacity of H525. The middle section of the of the thermal storage system was filled up with concrete in the middle 50% section and the bottom was filled up with low temperature molten salt of H325. This arrangement as shown in Fig. 26 offered the best cyclic performance between all the tests performed.

8.3. TES applications in district heating

As demonstrated in Fig. 27, thermal storage systems used in district heating systems are categorised into different classifications. It is discovered that combining district heating systems with thermal storage can provide various economical, environmental and technical advantages. Guelpa and Verda [11], studies the effect of employing thermal energy storage in district cooling and heating systems.

In this regard, short- and long- term system storage approaches were studied, and it was demonstrated how the technologies can be used in conjunction with district energy supply. In this regard, studies were conducted in relation to chemical, sensible and latent heat storage systems and the outlook for the progress of the current state-of-the-art technologies for next generation district heating and network-based energy delivery systems were performed.

8.4. Automotive applications

When it comes to automotive applications, it is indicated that Lithium-ion batteries which are used in electric vehicles currently offer the most direct link to thermal management. Lithium-ion batteries are currently classified as the most optimal option for electrical storage in electric vehicles and are considered to be highly safe, economical and available with no or little memory lost effect [84,85]. Lithium-ion batteries is a type of battery in which electrons travel from negative to positive during discharge and function in the opposite way during discharge [86]. The rapid movement of electrons will cause the battery pack to go through varies thermal conditions and as a result, a large amount of waste heat is generated from the battery pack. This will cause the battery to become less efficient and face faster runaway, shorter life and even explosion as it get hotter [84]. The performance of the Lithium-ion batteries therefore depends on having a proper cooling system and in this regard, it is investigated that the battery pack should operate in an optimum temperature ranging from 25 °C to 60 °C to deliver best efficiency [86].

This therefore has led to many investigations in particular the use of phase change material for thermal management of batteries. For instance, a thermal management system was developed using PCM for Lithium-ion batteries and it was discovered that combing graphene and carbon nanotubes as PCM additives can provide a suitable blend for heat dissipation from the battery cells [87]. The use of PCM not only offers balancing heat distribution but also provide good thermal conductivity and hence that is why is can be widely used for battery thermal management [88].

Using PCM also doesn't require and power output from the system and can act as a passive and effective method of thermal management for batteries [86]. Many researches have been conducted on the

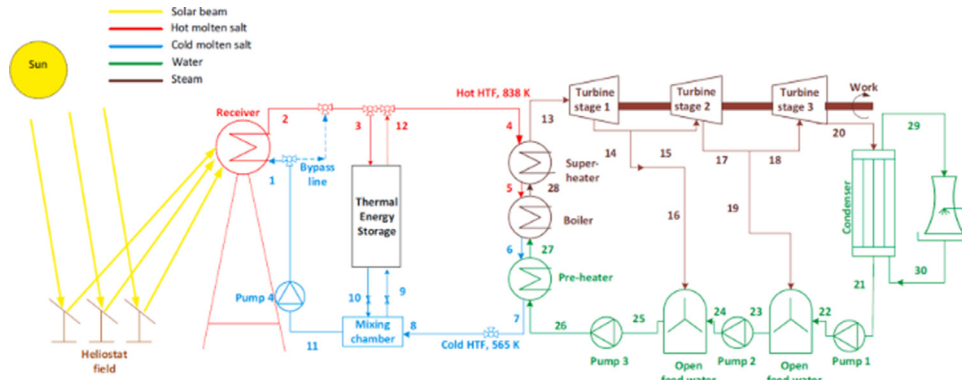

Fig. 25. Concentrating power plant configuration with molten salt based TES technology [24].

use of paraffin and non-paraffin materials for the development of PCM based cooling system and investigated that the peak temperature loads can be managed at an average temperature. Furthermore, the functionality of fatty acids such as Vinyl stearate, Methyl palmitate, and Dimethyl Sabacate have also been studied and in this regard, the benefit of having similar properties to paraffin and offering more rapid phase transformation have been observed.

For instance, the performance of Capric acid was studied and it was discovered that with a thickened of 3 mm of the material the temperature can be brought down to 305 K. Nevertheless, this result was indicated to be better than for paraffin wax which only brought down the temperature to 308 K but with 9 mm thickness. The conclusion of the study was that Capric acid offers better functionality than paraffin wax when it comes to developing a thermal management system since the thickness of the material used was much lower for obtaining a similar heat absorption result [86].

Having indicated that, the effect of employing and blending additives such as carbon fibre in different concentration of PCM was studied and experimental analysis concluded that a mixture of 2 mm long carbon fibres with a mass of 0.46% with PCM can provide a good thermal performance [85]. In this study, it was discovered that with the use of mentioned blend, the maximum temperature rise in the battery simulator can fall by nearly 45%.

In another research, the thermal performance of 25 parallel Lithium-ion batteries was tested and it was demonstrated that by using PCM based cooling, higher thermal conductivity from the cells and better thermal management can be obtained to reduce the maximum temperature and provide temperature uniformity for battery modules [89]. The results from a study conducted by Sun et al. [90] showed PCM material combined with cylindrical rings and longitudinal fins offer a higher performance for thermal management of a

battery system when compared to the use of only pure PCM. It was discovered that the use of fins can result in developing a bigger heat transfer area and work as a conductive network within the PCM material. The study concluded that by using 1 ring and 8 fins the thermal performance of a battery pack can be largely enhanced and the temperature of the module can be controlled even under low heat generation rate.

9. Numerical analysis

The main problem related to modelling phase change is related to moving-boundary problems. This means it is rather difficult to predict and simulate the moving interface that occurs due to the transformation of the material from solid to liquid phase. This issue is discovered to be mainly problematic due to the fundamental non-linear nature of the moving interfaces between PCM boundaries. Based on the conducted literature review, the simulation and analyses of phase change phenomena are achieved using computation tools such as COMSOL Multiphysics, ANSYS FLUENT and Star-CCM+. These software packages provide the capabilities to simulate systems that incorporate phase change processes over a specific range of temperature [9]. Having said that, it should be noted that simplifying governing equations are important when conducting computational analyses to reduce the time and computational costs needed to solve a complex problem as such [35].

Rathore et al. [12] indicated in summary an assessment of the studies conducted on computer simulation for the use of PCM in building materials. The review conducted mainly focused on examining the usage of micro-PCM for energy savings in buildings by providing indoor thermal comfort. Table 8 shows different modelling tools with their relative properties.

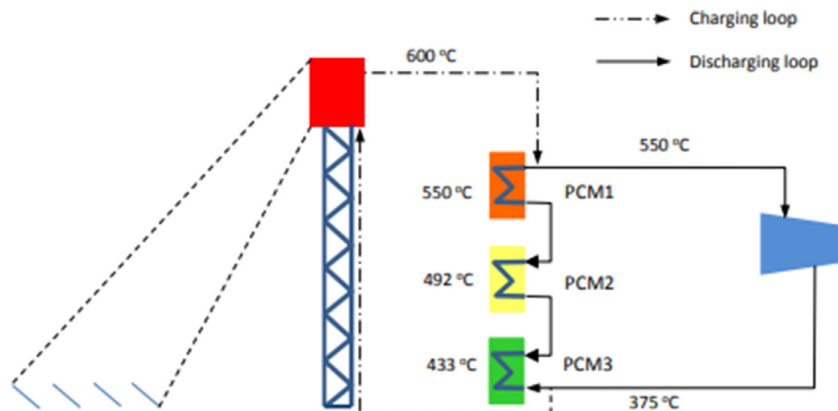

Fig. 26. Solar tower power plant with a cascade molten salt based TES device [83].

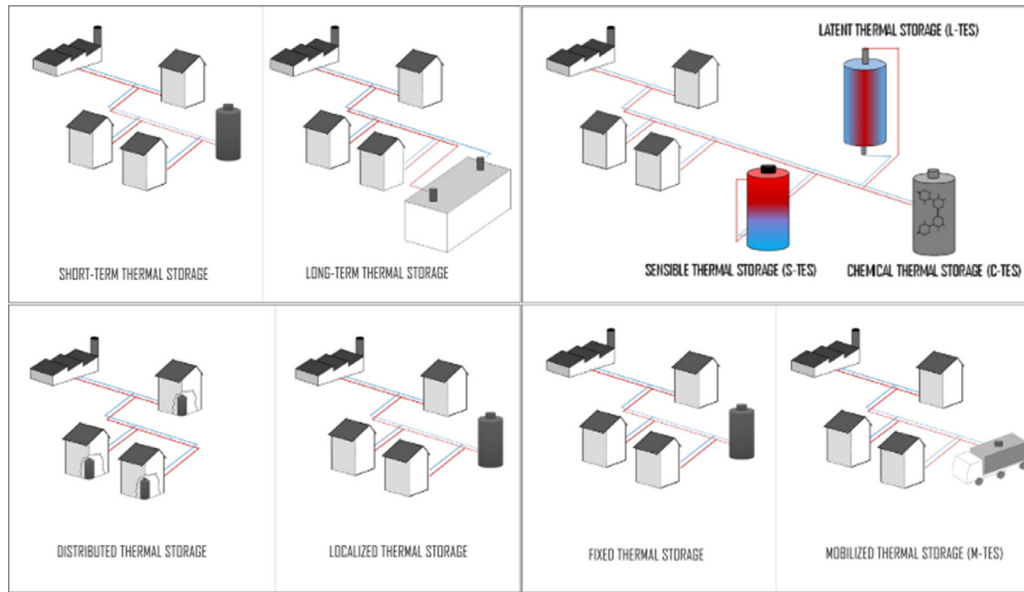

Fig. 27. TES used in different district heating systems.

It is discovered that modelling the thermohydraulic behaviour of thermal storage systems can be rather complex and difficult. Thus, it is discovered that a wide range of tools may be needed to model thermal storage systems. These tools according to Dahash et al. [91], can be classified into three main types:

(a) Energy system simulation (ESS) that includes simulation software such as Dymola, TRNSYS, Matlab/Simulink;

- (b) Building physics envelope heat and mass transfer that employs tools such as WUFI Pro and Delphin;
- (c) Computational fluid dynamics (CFD) software that can also be used to simulate building envelope and mass transfer such as ANSYS Fluent, OpenFOAM and COMSOL Multiphysics.

Table 8
Different modelling tools with relative properties.

Software tool	Properties	Reference
Graphitic materials	The technique was employed to estimate the thermal conductivity of carbon-based materials using a single model. Moreover, steady and unsteady state techniques are demonstrated.	[13]
MATLAB	MATLAB was employed to conduct economical evaluation of a PVT system that incorporates PCM material for heat absorption.	[34]
“XLSTAT” solution software of Excel	The tool was used to model and analyse the correlations and associations of different variables and to data analyse the power production performance of a PV/T system incorporated with cooling methods such as nano based PCMs. The tool was used as a viable solution to provide future estimation of experimental results.	[36]
An Artificial neural network (ANN)	The electrical power of the system was then predicted using linear mathematical and ANN models. In this regard, it is investigated that ANN as a powerful modelling tool can be used to simulate linear and non-linear relationships in the system with complex input and output associations.	[36]

Dahash et al. [91] also provided an overview of the most common techniques used in modelling thermal storage systems on a detailed component level, system level and the how coupling can be possible. An approximation was developed by Prasad et al. [43] to investigate the effect of natural convection inside the phase change material in a combined conduction-convection model. The governing equations involved were solved using finite element based simulation software using COMSOL Multiphysics.

A detailed numerical analysis was presented by Aljehani et al. [92] to demonstrate the transient behaviour of heat transfer in a phase change thermal energy storage system. On the other hand, Kubinski et al. [93] provided a simplified dynamic model in Aspen HYSYS software. It was shown that due to the complexity of the model, the system may be limited to a configuration that incorporates seasonal heat storage. It is discovered that conducting computational analyses through computational fluid dynamics (CFD) and finite element methods (FEMs) are the most favourable methods of conducting simulation for PCM based thermal storage systems [94].

As investigated by Yu et al. [65] heat transfer problems during the solidification and melting process can be simulated using FLUENT software. It was demonstrated that the software has a solidification-melting model, which can be used to solve such a model at a different temperature range. In this study, an innovative structure named pipe-embedded ventilation roof that incorporates an outer-layer PCM was proposed and modelled.

Zhu et al. [95] conducted a study to discover the relationship between different kinds of input parameters and output indicators in charging phase by coupling the 3D transient numerical method with the global sensitivity analysis method. This work was done to in order to evaluate how different supply temperatures affect the system efficiency. An aquifer thermal storage system for district heating and cooling was developed and simulated by Todorov et al. [96]. In this study, a model was developed and simulated at different periods of time using the finite difference code MODFLOW.

10. Conclusion

Thermal energy storage, commonly called heat and cold storage, allows heat or cold to be used later. Energy storage can be divided into many categories, but this article focuses on thermal energy storage because this is a key technology in energy systems for conserving energy and increasing energy efficiency. In this regard, the importance of energy storage was investigated, and it was explained how though utilising different technologies, thermal energy can be absorbed and stored for a later use.

In particular, thermal energy including sensible heat storage, latent heat storage and thermochemical energy storage systems were thoroughly analysed. It was explained that how by employing certain physical and chemical techniques, thermal energy in term of sensible and latent heat can be processed and stored. Furthermore, it was discovered that the most important factors for selecting and designing a storage vessel which should be into consideration are high energy storage density, cyclability, mechanical strength, low corrosion and chemical stability. In addition to this, the basic parameters determining the dynamics of change in the thermal storage systems were explained and different requirements for selection of different storage materials were described. In this regard, the use of phase change materials was discovered to be a viable solution for efficient storage of thermal energy.

Based on this, various classification of PCMs according to their chemical nature as organic, inorganic and eutectics were researched and the parameters, including advantages and disadvantages, that needed to be considered for the selection of an ideal thermal storage material were investigated. Nevertheless, the methods of enhancing the performance of PCM materials through macro-, micro-, and nano-encapsulation were discussed and it was demonstrated that how through employing these techniques, desirable environmental benefits can also be provided. Having indicated that, other approaches that can similarly improve the performance of the PCM materials were also demonstrated. For instance, it was indicated that techniques such as shape stabilisation can be applied to improve the energy storage ability and stability of PCM materials. In this regard and furthermore, different classification of supporting materials used for shape-stabilisation of PCMs were investigated and different case studies were illustrated, and it was shown that immense advantages can be obtained through utilising this particular method.

Nonetheless, it was also explained how the charging rate of the PCM material can significantly be enhanced with the increase in heat transfer and how cascaded latent heat thermal energy storage system are used as an ideal solution to improve charging and discharging of PCM based thermal storage systems. Moreover, it was shown which PCM materials are used at what specific temperature range and which types are in particular suitable to be employed for certain sectors and applications. In this regard, the usability of PCM materials as an ideal thermal storage solution in buildings, power generation, food industry as well as in automotive application were explained and it was concluded that significant overall energy performance improvements for the system can be obtained in these sectors. Last but not least, it was discovered that different tools can be used to computationally and numerically analyse the performance of phase change phenomena. It was discovered that the tools used mainly provide the capabilities to simulate systems that incorporate phase change processes over a specific range of temperature and can overcome the challenges that are associated with moving-boundary problems. Nevertheless, several case studies that employed different simulation tools were illustrated and it was concluded that good evaluation of the effect of employing different thermal storage systems on the efficiency of an application can be obtained without the need of experimental investigations.

Declaration of competing interest

None.

References

- [1] EASE, *Thermal Storage Position Paper*, EASE, 2017.
- [2] Commission Staff Working Document, *Energy storage – the role of electricity*, Eur. Comm. (2017) 1–25.
- [3] EASE-EERA, "Joint EASE/EERA Recommendations For A European Energy Storage Technology Development Roadmap Towards 2030," EASE -EERA.
- [4] A. Fallahi, G. Guldentops, M. Tao, S. Granados-Focil, S. Van Dessel, Review on solid-solid phase change materials for thermal energy storage: molecular structure and thermal properties, *Appl. Therm. Eng.* 127 (2017) 1427–1441, doi: [10.1016/j.applthermaleng.2017.08.161](https://doi.org/10.1016/j.applthermaleng.2017.08.161).
- [5] I. Sarbu, C. Sebarchievici, A comprehensive review of thermal energy storage, *Sustain* 10 (1) (2018), doi: [10.3390/su10010191](https://doi.org/10.3390/su10010191).
- [6] EASE-EERA, *Joint EASE/EERA Recommendations For a European Energy Storage Technology Development Roadmap 2017 Update*, EASE/EERA, 2017.
- [7] S. Koohi-Fayegh, M.A. Rosen, A review of energy storage types, applications and recent developments, *J. Energy Storage* 27 (July 2019) (2020) 101047, doi: [10.1016/j.est.2019.101047](https://doi.org/10.1016/j.est.2019.101047).
- [8] H. Mehling, L.F. Cabeza, *Heat and Cold Storage With PCM*, Springer Berlin Heidelberg, Berlin, Heidelberg, 2008.
- [9] C.N. Elias, V.N. Stathopoulos, A comprehensive review of recent advances in materials aspects of phase change materials in thermal energy storage, *Energy Procedia* 161 (2019) 385–394, doi: [10.1016/j.egypro.2019.02.101](https://doi.org/10.1016/j.egypro.2019.02.101).
- [10] P.K.S. Rathore, S.K. Shukla, Potential of macroencapsulated PCM for thermal energy storage in buildings: a comprehensive review, *Constr. Build. Mater.* 225 (2019) 723–744, doi: [10.1016/j.conbuildmat.2019.07.221](https://doi.org/10.1016/j.conbuildmat.2019.07.221).
- [11] E. Guelpa, V. Verda, Thermal energy storage in district heating and cooling systems: a review, *Appl. Energy* 252 (June) (2019) 113474, doi: [10.1016/j.apenergy.2019.113474](https://doi.org/10.1016/j.apenergy.2019.113474).
- [12] P.K.S. Rathore, S.K. Shukla, N.K. Gupta, Potential of microencapsulated PCM for energy savings in buildings: a critical review, *Sustain. Cities Soc.* 53 (August 2019) (2020) 101884, doi: [10.1016/j.scs.2019.101884](https://doi.org/10.1016/j.scs.2019.101884).
- [13] H. Badenhorst, A review of the application of carbon materials in solar thermal energy storage, *Sol. Energy* 192 (September 2017) (2018) 35–68, doi: [10.1016/j.solener.2018.01.062](https://doi.org/10.1016/j.solener.2018.01.062).
- [14] A. Palacios, L. Cong, M.E. Navarro, Y. Ding, C. Barreneche, Thermal conductivity measurement techniques for characterizing thermal energy storage materials – a review, *Renew. Sustain. Energy Rev.* 108 (November 2018) (2019) 32–52, doi: [10.1016/j.rser.2019.03.020](https://doi.org/10.1016/j.rser.2019.03.020).
- [15] J. Gasia, L. Miró, L.F. Cabeza, Review on system and materials requirements for high temperature thermal energy storage. Part 1: general requirements, *Renew. Sustain. Energy Rev.* 75 (December 2016) (2017) 1320–1338, doi: [10.1016/j.rser.2016.11.119](https://doi.org/10.1016/j.rser.2016.11.119).
- [16] K.P.S. Rathore, S.K. Shukla, Potential of macroencapsulated PCM for thermal energy storage in buildings : a comprehensive review, *Constr. Build. Mater.* 225 (2019) 723–744, doi: [10.1016/j.conbuildmat.2019.07.221](https://doi.org/10.1016/j.conbuildmat.2019.07.221).
- [17] G. Li, Energy and exergy performance assessments for latent heat thermal energy storage systems, *Renew. Sustain. Energy Rev.* 51 (2015) 926–954, doi: [10.1016/j.rser.2015.06.052](https://doi.org/10.1016/j.rser.2015.06.052).
- [18] J. Sunku Prasad, P. Muthukumar, F. Desai, D.N. Basu, M.M. Rahman, A critical review of high-temperature reversible thermochemical energy storage systems, *Appl. Energy* 254 (October 2018) (2019) 113733, doi: [10.1016/j.apenergy.2019.113733](https://doi.org/10.1016/j.apenergy.2019.113733).
- [19] C. Prieto, P. Cooper, A.I. Fernández, L.F. Cabeza, Review of technology: thermochemical energy storage for concentrated solar power plants, *Renew. Sustain. Energy Rev.* 60 (2016) 909–929, doi: [10.1016/j.rser.2015.12.364](https://doi.org/10.1016/j.rser.2015.12.364).
- [20] S. Bennici, T. Polimann, M. Ondarts, E. Gonze, C. Vaulot, N. Le Pierrès, Long-term impact of air pollutants on thermochemical heat storage materials, *Renew. Sustain. Energy Rev.* 117 (June 2019) (2020), doi: [10.1016/j.rser.2019.109473](https://doi.org/10.1016/j.rser.2019.109473).
- [21] X. Sun, Y. Mo, J. Li, Y. Chu, L. Liu, S. Liao, Study on the energy charging process of a plate-type latent heat thermal energy storage unit and optimization using Taguchi method, *Appl. Therm. Eng.* 164 (October 2019) (2020) 114528, doi: [10.1016/j.applthermaleng.2019.114528](https://doi.org/10.1016/j.applthermaleng.2019.114528).
- [22] S.S. Magendran, et al., Synthesis of organic phase change materials (PCM) for energy storage applications: a review, *Nano Struct. Nano Obj.* 20 (2019) 100399, doi: [10.1016/j.nanoso.2019.100399](https://doi.org/10.1016/j.nanoso.2019.100399).
- [23] J. Yu, et al., Thermal performance evaluation and optimal design of building roof with outer-layer shape-stabilized PCM, *Renew. Energy* 145 (2020) 2538–2549, doi: [10.1016/j.renene.2019.08.026](https://doi.org/10.1016/j.renene.2019.08.026).
- [24] Q. Li, C. Li, Z. Du, F. Jiang, Y. Ding, A review of performance investigation and enhancement of shell and tube thermal energy storage device containing molten salt based phase change materials for medium and high temperature applications, *Appl. Energy* 255 (September 2019) (2019) 113806, doi: [10.1016/j.apenergy.2019.113806](https://doi.org/10.1016/j.apenergy.2019.113806).
- [25] S. Wu, T. Yan, Z. Kuai, W. Pan, Thermal conductivity enhancement on phase change materials for thermal energy storage: a review, *Energy Storage Mater.* 12 (1) (2019), doi: [10.3390/en12010075](https://doi.org/10.3390/en12010075).
- [26] A. Reyes, L. Henríquez-Vargas, J. Vásquez, N. Pailahueque, G. Aguilar, Analysis of a laboratory scale thermal energy accumulator using two-phases heterogeneous

- paraffin wax-water mixtures, *Renew. Energy* 145 (2020) 41–51, doi: [10.1016/j.renene.2019.06.007](https://doi.org/10.1016/j.renene.2019.06.007).
- [27] B. Chen, F. Kuznik, M. Horgnies, K. Johannes, V. Morin, E. Gengembre, Physico-chemical properties of ettringite/meta-ettringite for thermal energy storage: a review, *Sol. Energy Mater. Sol. Cells* 193 (December 2018) (2019) 320–334, doi: [10.1016/j.solmat.2018.12.013](https://doi.org/10.1016/j.solmat.2018.12.013).
- [28] D. Li, Y. Wu, B. Wang, C. Liu, M. Arici, Optical and thermal performance of glazing units containing PCM in buildings: a review, *Constr. Build. Mater.* 233 (2020) 117327, doi: [10.1016/j.conbuildmat.2019.117327](https://doi.org/10.1016/j.conbuildmat.2019.117327).
- [29] Z.A. Qureshi, H.M. Ali, S. Khushnood, Recent advances on thermal conductivity enhancement of phase change materials for energy storage system: a review, *Int. J. Heat Mass Transf.* 127 (2018) 838–856, doi: [10.1016/j.ijheatmasstransfer.2018.08.049](https://doi.org/10.1016/j.ijheatmasstransfer.2018.08.049).
- [30] E. Alehosseini, S.M. Jafari, Micro/nano-encapsulated phase change materials (PCMs) as emerging materials for the food industry, *Trends Food Sci. Technol.* 91 (October 2018) (2019) 116–128, doi: [10.1016/j.tifs.2019.07.003](https://doi.org/10.1016/j.tifs.2019.07.003).
- [31] M.M. Umair, Y. Zhang, K. Iqbal, S. Zhang, B. Tang, Novel strategies and supporting materials applied to shape-stabilize organic phase change materials for thermal energy storage—a review, *Appl. Energy* 235 (October 2018) (2019) 846–873, doi: [10.1016/j.apenergy.2018.11.017](https://doi.org/10.1016/j.apenergy.2018.11.017).
- [32] G. Alva, Y. Lin, L. Liu, G. Fang, Synthesis, characterization and applications of microencapsulated phase change materials in thermal energy storage: a review, *Energy Build.* 144 (2017) 276–294, doi: [10.1016/j.enbuild.2017.03.063](https://doi.org/10.1016/j.enbuild.2017.03.063).
- [33] X. Huang, C. Zhu, Y. Lin, G. Fang, Thermal properties and applications of microencapsulated PCM for thermal energy storage: a review, *Appl. Therm. Eng.* 147 (October 2018) (2019) 841–855, doi: [10.1016/j.applthermaleng.2018.11.007](https://doi.org/10.1016/j.applthermaleng.2018.11.007).
- [34] A.H.A. Al-Waeli, H.A. Kazem, M.T. Chaichan, K. Sopian, Experimental investigation of using nano-PCM/nanofluid on a photovoltaic thermal system (PVT): technical and economic study, *Therm. Sci. Eng. Prog.* 11 (November 2018) (2019) 213–230, doi: [10.1016/j.tsep.2019.04.002](https://doi.org/10.1016/j.tsep.2019.04.002).
- [35] J.M. Mahdi, S. Lohrasbi, E.C. Nsofor, Hybrid heat transfer enhancement for latent-heat thermal energy storage systems: a review, *Int. J. Heat Mass Transf.* 137 (2019) 630–649, doi: [10.1016/j.ijheatmasstransfer.2019.03.111](https://doi.org/10.1016/j.ijheatmasstransfer.2019.03.111).
- [36] A.H.A. Al-Waeli, H.A. Kazem, J.H. Yousif, M.T. Chaichan, K. Sopian, Mathematical and neural network modeling for predicting and analyzing of nanofluid-nano PCM photovoltaic thermal systems performance, *Renew. Energy* 145 (2020) 963–980, doi: [10.1016/j.renene.2019.06.099](https://doi.org/10.1016/j.renene.2019.06.099).
- [37] H. Gao, et al., Nanoconfinement effects on thermal properties of nanoporous shape-stabilized composite PCMs: a review, *Nano Energy* 53 (August) (2018) 769–797, doi: [10.1016/j.nanoen.2018.09.007](https://doi.org/10.1016/j.nanoen.2018.09.007).
- [38] Y. Qu, S. Wang, Y. Tian, D. Zhou, Comprehensive evaluation of Paraffin-HDPE shape stabilized PCM with hybrid carbon nano-additives, *Appl. Therm. Eng.* 163 (March) (2019), doi: [10.1016/j.applthermaleng.2019.114404](https://doi.org/10.1016/j.applthermaleng.2019.114404).
- [39] Y. Lu, et al., Fabrication and characterization of the novel shape-stabilized composite PCMs of Na₂CO₃-K₂CO₃/MgO/glass, *Sol. Energy* 189 (June) (2019) 228–234, doi: [10.1016/j.solener.2019.07.064](https://doi.org/10.1016/j.solener.2019.07.064).
- [40] C. Wang, L. Feng, W. Li, J. Zheng, W. Tian, X. Li, Shape-stabilized phase change materials based on polyethylene glycol/porous carbon composite: the influence of the pore structure of the carbon materials, *Sol. Energy Mater. Sol. Cells* 105 (Oct. 2012) 21–26, doi: [10.1016/j.solmat.2012.05.031](https://doi.org/10.1016/j.solmat.2012.05.031).
- [41] W.L. Cheng, Y.K. Huo, Y. Le Nian, Performance of solar still using shape-stabilized PCM: experimental and theoretical investigation, *Desalination* 455 (October 2018) (2019) 89–99, doi: [10.1016/j.desal.2019.01.007](https://doi.org/10.1016/j.desal.2019.01.007).
- [42] H.J. Xu, C.Y. Zhao, Analytical considerations on optimization of cascaded heat transfer process for thermal storage system with principles of thermodynamics, *Renew. Energy* 132 (2019) 826–845, doi: [10.1016/j.renene.2018.07.135](https://doi.org/10.1016/j.renene.2018.07.135).
- [43] J. Sunku Prasad, P. Muthukumar, R. Anandalakshmi, H. Niyas, Comparative study of phase change phenomenon in high temperature cascade latent heat energy storage system using conduction and conduction-convection models, *Sol. Energy* 176 (October) (2018) 627–637, doi: [10.1016/j.solener.2018.10.048](https://doi.org/10.1016/j.solener.2018.10.048).
- [44] H.J. Xu, C.Y. Zhao, Thermal performance of cascaded thermal storage with phase-change materials (PCMs). Part I: steady cases, *Int. J. Heat Mass Transf.* 106 (2017) 932–944, doi: [10.1016/j.ijheatmasstransfer.2016.10.054](https://doi.org/10.1016/j.ijheatmasstransfer.2016.10.054).
- [45] H.J. Xu, C.Y. Zhao, Thermal performance of cascaded thermal storage with phase-change materials (PCMs). Part II: unsteady cases, *Int. J. Heat Mass Transf.* 106 (2017) 945–957, doi: [10.1016/j.ijheatmasstransfer.2016.10.066](https://doi.org/10.1016/j.ijheatmasstransfer.2016.10.066).
- [46] H. Chirino, B. Xu, X. Xu, Parametric study of cascade latent heat thermal energy storage (CLHTES) system in concentrated solar power (CSP) plants, *J. Energy Inst.* 92 (3) (2019) 653–664, doi: [10.1016/j.joei.2018.03.007](https://doi.org/10.1016/j.joei.2018.03.007).
- [47] J.O. Khor, J.Y. Sze, Y. Li, and A. Romagnoli, “Overcharging of a Cascaded Packed Bed Thermal Energy Storage : Effects and Solutions,” vol. 117, no. September 2019, 2020, doi: [10.1016/j.rser.2019.109421](https://doi.org/10.1016/j.rser.2019.109421).
- [48] S.S. Mostafavi Tehrani, Y. Shoraka, K. Nithyanandam, R.A. Taylor, Cyclic performance of cascaded and multi-layered solid-PCM shell-and-tube thermal energy storage systems: a case study of the 19.9 MW e Gemasolar CSP plant, *Appl. Energy* 228 (March) (2018) 240–253, doi: [10.1016/j.apenergy.2018.06.084](https://doi.org/10.1016/j.apenergy.2018.06.084).
- [49] M.J. Tessier, M.C. Floros, L. Bouzidi, S.S. Narine, Exergy analysis of an adiabatic compressed air energy storage system using a cascade of phase change materials, *Energy* 106 (2016) 528–534, doi: [10.1016/j.energy.2016.03.042](https://doi.org/10.1016/j.energy.2016.03.042).
- [50] H. Shamsi, M. Boroushaki, H. Gerai, Performance evaluation and optimization of encapsulated cascade PCM thermal storage, *J. Energy Storage* 11 (2017) 64–75, doi: [10.1016/j.est.2017.02.003](https://doi.org/10.1016/j.est.2017.02.003).
- [51] J. Gasia, L. Miró, L.F. Cabeza, Review on system and materials requirements for high temperature thermal energy storage. Part 1: general requirements, *Renew. Sustain. Energy Rev.* 75 (May 2016) (2017) 1320–1338, doi: [10.1016/j.rser.2016.11.119](https://doi.org/10.1016/j.rser.2016.11.119).
- [52] G. Mohan, M.B. Venkataraman, J. Coventry, Sensible energy storage options for concentrating solar power plants operating above 600°C, *Renew. Sustain. Energy Rev.* 107 (January) (2019) 319–337, doi: [10.1016/j.rser.2019.01.062](https://doi.org/10.1016/j.rser.2019.01.062).
- [53] A. Vukadinović, J. Radosavljević, A. Đorđević, Energy performance impact of using phase-change materials in thermal storage walls of detached residential buildings with a sunspace, *Sol. Energy* 206 (June) (2020) 228–244, doi: [10.1016/j.solener.2020.06.008](https://doi.org/10.1016/j.solener.2020.06.008).
- [54] R. Arivazhagan, S. Arun Prakash, P. Kumaran, S. Sankar, G.B. Loganathan, A. Arivarasan, Performance analysis of concrete block integrated with PCM for thermal management, *Mater. Today Proc.* 22 (2020) 370–374, doi: [10.1016/j.matpr.2019.06.714](https://doi.org/10.1016/j.matpr.2019.06.714).
- [55] P.K.S. Rathore, S.K. Shukla, An experimental evaluation of thermal behavior of the building envelope using macroencapsulated PCM for energy savings, *Renew. Energy* 149 (2020) 1300–1313, doi: [10.1016/j.renene.2019.10.130](https://doi.org/10.1016/j.renene.2019.10.130).
- [56] M. Dardir, L. Roccamena, M. El Mankibi, F. Haghighat, Performance analysis of an improved PCM-to-air heat exchanger for building envelope applications – an experimental study, *Sol. Energy* 199 (August 2019) (2020) 704–720, doi: [10.1016/j.solener.2020.02.072](https://doi.org/10.1016/j.solener.2020.02.072).
- [57] R.J. Khan, M.Z.H. Bhuiyan, D.H. Ahmed, Investigation of heat transfer of a building wall in the presence of phase change material (PCM), *Energy Built Environ.* 1 (2) (2020) 199–206, doi: [10.1016/j.enbenv.2020.01.002](https://doi.org/10.1016/j.enbenv.2020.01.002).
- [58] M. Arici, F. Bilgin, S. Nizetic, H. Karabay, PCM integrated to external building walls: an optimization study on maximum activation of latent heat, *Appl. Therm. Eng.* 165 (September 2019) (2020), doi: [10.1016/j.applthermaleng.2019.114560](https://doi.org/10.1016/j.applthermaleng.2019.114560).
- [59] Y. Yang, W. Wu, S. Fu, H. Zhang, Study of a novel ceramsite-based shape-stabilized composite phase change material (PCM) for energy conservation in buildings, *Constr. Build. Mater.* 246 (2020) 118479, doi: [10.1016/j.conbuildmat.2020.118479](https://doi.org/10.1016/j.conbuildmat.2020.118479).
- [60] S. Wijesuriya, P.C. Tabares-Velasco, K. Biswas, D. Heim, Empirical validation and comparison of PCM modeling algorithms commonly used in building energy and hydrothermal software, *Build. Environ.* 173 (November 2019) (2020) 106750, doi: [10.1016/j.buildenv.2020.106750](https://doi.org/10.1016/j.buildenv.2020.106750).
- [61] M. Rym, E. Klugmann-Radziemska, Possibilities and benefits of a new method of modifying conventional building materials with phase-change materials (PCMs), *Constr. Build. Mater.* 211 (2019) 1013–1024, doi: [10.1016/j.conbuildmat.2019.03.277](https://doi.org/10.1016/j.conbuildmat.2019.03.277).
- [62] H. Wang, W. Lu, Z. Wu, G. Zhang, Parametric analysis of applying PCM wallboards for energy saving in high-rise lightweight buildings in Shanghai, *Renew. Energy* 145 (2020) 52–64, doi: [10.1016/j.renene.2019.05.124](https://doi.org/10.1016/j.renene.2019.05.124).
- [63] S. Kenzhekhanov, S.A. Memon, I. Adilkanova, Quantitative evaluation of thermal performance and energy saving potential of the building integrated with PCM in a subarctic climate, *Energy* 192 (2020) 116607, doi: [10.1016/j.energy.2019.116607](https://doi.org/10.1016/j.energy.2019.116607).
- [64] D.K. Bhamare, M.K. Rathod, J. Banerjee, Numerical model for evaluating thermal performance of residential building roof integrated with inclined phase change material (PCM) layer, *J. Build. Eng.* 28 (September 2019) (2020) 101018, doi: [10.1016/j.jobte.2019.101018](https://doi.org/10.1016/j.jobte.2019.101018).
- [65] J. Yu, et al., Study on thermal insulation characteristics and optimized design of pipe-embedded ventilation roof with outer-layer shape-stabilized PCM in different climate zones, *Renew. Energy* 147 (2020) 1609–1622, doi: [10.1016/j.renene.2019.09.115](https://doi.org/10.1016/j.renene.2019.09.115).
- [66] A. Kasaëian, L. bahrami, F. Pourfayaz, E. Khodabandeh, W.M. Yan, Experimental studies on the applications of PCMs and nano-PCMs in buildings: a critical review, *Energy Build.* 154 (2017) 96–112, doi: [10.1016/j.enbuild.2017.08.037](https://doi.org/10.1016/j.enbuild.2017.08.037).
- [67] B.P. Jelle, S.E. Kalnæs, Phase change materials for application in energy-efficient buildings, *Cost Effect. Energy Effic. Build. Retrofit.* (2017) 57–118, doi: [10.1016/B978-0-08-101128-7.00003-4](https://doi.org/10.1016/B978-0-08-101128-7.00003-4).
- [68] Faye C. McQuiston, Jerald D. Parker, Jeffrey D. Spitler, *Heating, Ventilating and Air Conditioning Analysis and Design*, 6th ed, John Wiley & Sons, Inc., 2005.
- [69] F. Souayfane, F. Fardoun, P.H. Biwole, Phase change materials (PCM) for cooling applications in buildings: a review, *Energy Build.* 129 (2016) 396–431, doi: [10.1016/j.enbuild.2016.04.006](https://doi.org/10.1016/j.enbuild.2016.04.006).
- [70] Y. Li, S. Liu, J. Lu, Effects of various parameters of a PCM on thermal performance of a solar chimney, *Appl. Therm. Eng.* 127 (2017) 1119–1131, doi: [10.1016/j.applthermaleng.2017.08.087](https://doi.org/10.1016/j.applthermaleng.2017.08.087).
- [71] K.O. Lee, M.A. Medina, X. Sun, X. Jin, Thermal performance of phase change materials (PCM)-enhanced cellulose insulation in passive solar residential building walls, *Sol. Energy* 163 (November 2017) (2018) 113–121, doi: [10.1016/j.solener.2018.01.086](https://doi.org/10.1016/j.solener.2018.01.086).
- [72] G. Pavlov, B. Olesen, *Building thermal energy storage-concepts and applications*, in: *Proceedings of the 12th ROOMVENT Conference*, 2011.
- [73] Y. Sun, S. Wang, F. Xiao, D. Gao, Peak load shifting control using different cold thermal energy storage facilities in commercial buildings : a review, *Energy Convers. Manag.* 71 (2013) 101–114, doi: [10.1016/j.enconman.2013.03.026](https://doi.org/10.1016/j.enconman.2013.03.026).
- [74] A. Waqas, Z. Ud, Phase change material (PCM) storage for free cooling of buildings – a review, *Renew. Sustain. Energy Rev.* 18 (2013) 607–625, doi: [10.1016/j.rser.2012.10.034](https://doi.org/10.1016/j.rser.2012.10.034).
- [75] A. De Gracia, L. Navarro, A. Castell, Á. Ruiz-pardo, S. Álvarez, L.F. Cabeza, Experimental study of a ventilated facade with PCM during winter period, *Energy Build.* 58 (2013) 324–332, doi: [10.1016/j.enbuild.2012.10.026](https://doi.org/10.1016/j.enbuild.2012.10.026).
- [76] M. Delgado, A. Lázaro, J. Mazo, B. Zalba, Review on phase change material emulsions and microencapsulated phase change material slurries : materials, heat transfer studies and applications, *Renew. Sustain. Energy Rev.* 16 (1) (2012) 253–273, doi: [10.1016/j.rser.2011.07.152](https://doi.org/10.1016/j.rser.2011.07.152).
- [77] A.C. Marques, G.F. Davies, G.G. Maidment, J.A. Evans, I.D. Wood, Novel design and performance enhancement of domestic refrigerators with thermal storage, *Appl. Therm. Eng.* 63 (2) (2014) 511–519, doi: [10.1016/j.applthermaleng.2013.11.043](https://doi.org/10.1016/j.applthermaleng.2013.11.043).

- [78] A.C. Marques, G.F. Davies, J.A. Evans, G.G. Maidment, I.D. Wood, Theoretical modelling and experimental investigation of a thermal energy storage refrigerator, *Energy* 55 (2013) 457–465, doi: [10.1016/j.energy.2013.03.091](https://doi.org/10.1016/j.energy.2013.03.091).
- [79] K. Azzouz, D. Leducq, D. Gobin, Enhancing the performance of household refrigerators with latent heat storage : an experimental investigation ' risation experimientale de la performance d ' un Caracte ' frige ' rateur domestique muni d ' un accumulateur a ' chaleur re latente, *Int. J. Refrig.* 32 (7) (2009) 1634–1644, doi: [10.1016/j.ijrefrig.2009.03.012](https://doi.org/10.1016/j.ijrefrig.2009.03.012).
- [80] T. Ma, Z. Li, J. Zhao, Photovoltaic panel integrated with phase change materials (PV-PCM): technology overview and materials selection, *Renew. Sustain. Energy Rev.* 116 (September) (2019) 109406, doi: [10.1016/j.rser.2019.109406](https://doi.org/10.1016/j.rser.2019.109406).
- [81] M. Rahimi, S.S. Ardahaie, M.J. Hosseini, M. Gorzin, Energy and exergy analysis of an experimentally examined latent heat thermal energy storage system, *Renew. Energy* 147 (2020) 1845–1860, doi: [10.1016/j.renene.2019.09.121](https://doi.org/10.1016/j.renene.2019.09.121).
- [82] K.R. Arun, M. Srinivas, C.A. Saleel, S. Jayaraj, Influence of the location of discrete macro-encapsulated thermal energy storage on the performance of a double pass solar plate collector system, *Renew. Energy* 146 (2020) 675–686, doi: [10.1016/j.renene.2019.07.036](https://doi.org/10.1016/j.renene.2019.07.036).
- [83] M. Liu, N.H.S. Tay, M. Belusko, F. Bruno, Investigation of cascaded shell and tube latent heat storage systems for solar tower power plants, *Energy Procedia* 69 (2015) 913–924, doi: [10.1016/j.egypro.2015.03.175](https://doi.org/10.1016/j.egypro.2015.03.175).
- [84] K.S. Kshetrimayum, Y.G. Yoon, H.R. Gye, C.J. Lee, Preventing heat propagation and thermal runaway in electric vehicle battery modules using integrated PCM and micro-channel plate cooling system, *Appl. Therm. Eng.* 159 (April) (2019) 113797, doi: [10.1016/j.applthermaleng.2019.113797](https://doi.org/10.1016/j.applthermaleng.2019.113797).
- [85] A. Babapoor, M. Azizi, G. Karimi, Thermal management of a Li-ion battery using carbon fiber-PCM composites, *Appl. Therm. Eng.* 82 (2015) 281–290, doi: [10.1016/j.applthermaleng.2015.02.068](https://doi.org/10.1016/j.applthermaleng.2015.02.068).
- [86] A. Verma, S. Shashidhara, D. Rakshit, A comparative study on battery thermal management using phase change material (PCM), *Therm. Sci. Eng. Prog.* 11 (November 2018) (2019) 74–83, doi: [10.1016/j.tsep.2019.03.003](https://doi.org/10.1016/j.tsep.2019.03.003).
- [87] D. Zou, X. Ma, X. Liu, P. Zheng, Y. Hu, Thermal performance enhancement of composite phase change materials (PCM) using graphene and carbon nanotubes as additives for the potential application in lithium-ion power battery, *Int. J. Heat Mass Transf.* 120 (2018) 33–41, doi: [10.1016/j.ijheatmasstransfer.2017.12.024](https://doi.org/10.1016/j.ijheatmasstransfer.2017.12.024).
- [88] J. Weng, X. Yang, G. Zhang, D. Ouyang, M. Chen, J. Wang, Optimization of the detailed factors in a phase-change-material module for battery thermal management, *Int. J. Heat Mass Transf.* 138 (2019) 126–134, doi: [10.1016/j.ijheatmasstransfer.2019.04.050](https://doi.org/10.1016/j.ijheatmasstransfer.2019.04.050).
- [89] R. Huang, Z. Li, W. Hong, Q. Wu, X. Yu, Experimental and numerical study of PCM thermophysical parameters on lithium-ion battery thermal management, *Energy Rep.* (2019), doi: [10.1016/j.egypr.2019.09.060](https://doi.org/10.1016/j.egypr.2019.09.060).
- [90] Z. Sun, R. Fan, F. Yan, T. Zhou, N. Zheng, Thermal management of the lithium-ion battery by the composite PCM-Fin structures, *Int. J. Heat Mass Transf.* 145 (2019) 118739, doi: [10.1016/j.ijheatmasstransfer.2019.118739](https://doi.org/10.1016/j.ijheatmasstransfer.2019.118739).
- [91] A. Dahash, F. Ochs, M.B. Janetti, W. Streicher, Advances in seasonal thermal energy storage for solar district heating applications: a critical review on large-scale hot-water tank and pit thermal energy storage systems, *Appl. Energy* 239 (December 2018) (2019) 296–315, doi: [10.1016/j.apenergy.2019.01.189](https://doi.org/10.1016/j.apenergy.2019.01.189).
- [92] A. Aljehani, L.C. Nitsche, S. Al-Hallaj, Numerical modeling of transient heat transfer in a phase change composite thermal energy storage (PCC-TES) system for air conditioning applications, *Appl. Therm. Eng.* 164 (September 2019) (2020) 114522, doi: [10.1016/j.applthermaleng.2019.114522](https://doi.org/10.1016/j.applthermaleng.2019.114522).
- [93] K. Kubiński, Ł. Szablowski, Dynamic model of solar heating plant with seasonal thermal energy storage, *Renew. Energy* 145 (2020) 2025–2033, doi: [10.1016/j.renene.2019.07.120](https://doi.org/10.1016/j.renene.2019.07.120).
- [94] J. Jaguemont, N. Omar, P. Van den Bossche, J. Mierlo, Phase-change materials (PCM) for automotive applications: a review, *Appl. Therm. Eng.* 132 (December 2018) (2018) 308–320, doi: [10.1016/j.rser.2019.03.020](https://doi.org/10.1016/j.rser.2019.03.020).
- [95] L. Zhu, S. Chen, Y. Yang, W. Tian, Y. Sun, M. Lyu, Global sensitivity analysis on borehole thermal energy storage performances under intermittent operation mode in the first charging phase, *Renew. Energy* 143 (2019) 183–198, doi: [10.1016/j.renene.2019.05.010](https://doi.org/10.1016/j.renene.2019.05.010).
- [96] O. Todorov, K. Alanne, M. Virtanen, and R. Kosonen, "A method and analysis of aquifer thermal energy storage (ATES) system for district heating and cooling: a case study in Finland," *Sustain. Cities Soc.*, pp. 437–453, 2019, doi: [10.1016/j.scs.2019.101977](https://doi.org/10.1016/j.scs.2019.101977).