

# The Effect of Square Finned Conformal Cooling (SFCC) on Cycle Time for Plastic Injection Moulding

K. Kamarudin\*, M.S. Wahab, M. Ibrahim, M.F.M. Batcha,  
A.A. Raus, Aqeel Ahmed, N. Sa'ude  
Faculty of Mechanical and Manufacturing Engineering,  
Universiti Tun Hussein Onn Malaysia,  
Parit Raja, Batu Pahat, Johor, Malaysia  
\*khairu.uthm@gmail.com

Z. Shayfull, S.M. Nasir  
Green Design and Manufacture Research Group,  
COE Geopolymer & Green Technology (CEGeoGTech),  
School of Materials Engineering, Universiti Malaysia Perlis, Malaysia

## ABSTRACT

Cooling system is a significant factor in productivity and quality in the plastic injection moulding process. Numerous researchers demonstrated that conformal cooling channel yields significant improvement of productivity and quality of plastic injection moulding process. Apart from that, the advancement of Solid Free Form Technology (SFF) allows a mould designer to design a variety of conformal cooling channel geometry rather than conventional designs. This paper presents the research work to enhance the efficiency of square shaped groove conformal cooling channels which uses fins concept. Existing conformal cooling channel design that uses square shape groove was improved by incorporating fins to meet the best design that can reduce the cooling time. The effect of Square Finned Conformal Cooling (SFCC) design on cooling time was investigated by using Autodesk Moldflow Insight software. The simulation results indicated that different number of fins influences the cooling time. From the analysis, it was found that time to reach the ejection temperature was reduced by 19.4% for the cooling channels with 4 fins compared to existing cooling channel.

**Keywords:** Conformal Cooling Channel, Cycle Time, Fin, Square Finned Conformal Cooling (SFCC)

## **Introduction**

The main stages in injection molding process starts with a filling process followed by packing, cooling and finally with ejection process [1]. The injection moulding cycle start with injection stage by inject the molten plastic into the cavities. The molten plastics are continuously fill the space until the gate freeze in packing stage. The mould will open and moulded part was ejected after the molten plastics are fully rigid. Next the moulds are closed for the consequent cycle. On the contrary, cooling phase is the most significant step amongst other stages, it regulates the rate about 70% to 80% in injection moulding process [2– 4].

Heat from molten plastic will be transferred from the mould plate via the cooling channels continuously until it reaches the ejection temperature [5].

The most common method of heat removal through cooling channel applications in plastic injection moulding relies on conventional drilling. The conventional cooling channels in simple shapes such round profile is fabricated by drilling straight line holes. These conventional cooling channel will lead to non-uniform mould cooling [6] that will increase the cooling time and lead to the imperfection of the molded part such warpage, sink mark and differential shrinkage.

Consequently, conformal cooling channels (CCC) present a practical solution to guarantee that the layout of cooling channels tracks the shape of molded parts with the closeness between the cooling channels and the mold surface is maintained. Solid free form fabrications technology (SFF) such Selective Laser Melting (SLM) and Direct Metal Laser Sintering (DMLS) technique are able to fabricate mould inserts with different cross sectional shapes such as circular, oval, rectangular, etc. Furthermore, SFF can be used to create coolant line along with the shape of plastic part [7]. However, researchers still not fully optimize the CCC design due to the ability of the SFF technology to fabricate the complexes geometry.

There are many methods that applied in heat transfer enhancement in engineering application such as air conditioning, heat exchanger, refrigeration systems and chemical reactor. One of the most important techniques used are passive heat transfer technique. These techniques was proven able to improve the overall thermal performance significantly when adopted in heat exchanger [8].

The passive enhancement methods are not required external power to sustain the enhancement characteristic and rely on the use of treated surface, rough surface, extended surface, coiled tubes and so on.

Researchers have reported their work in increasing the efficiency of cooling system in plastic injection molding. Hamdy and Nicolas [9] reported that cooling channel with the longest perimeter provided the shortest cooling

time by comparing the cooling efficiency of few type of cooling profile (square, circular and rectangular). The cooling channel provided through similar surface area but contrast in perimeter.

Altaf et al. [10] increased the heat dissipation to 14.6% by using profiled cross section conformal cooling channel compared to circular cross section profile. They study the circular cup product that design with both channel type with  $78.5\text{mm}^2$  cross section area. While the normal water with  $25^\circ\text{C}$  as coolant and simulate both cooling channel type to look the thermal distribution by ANSYS software. Cooling time, injection-molding cycle time, and part deflection were compared to conventional cooling channels with a diameter of 8 mm and 16 mm baffle diameter. Both injection molds used  $20^\circ\text{C}$  normal water as a coolant, and ABS with 20% glass fiber as the plastic material. Moldflow software was used to predict the deflection distribution, thermal variation, and cooling time of the injection-molding process. Experimental results showed that with conformal cooling channels, the cooling time was reduced by 35%, injection-molding cycle time was reduced by 25.7% and molded parts deflection was reduced by 28% from 1 to 0.72mm.

Manat et al [11] reported method to increase heat transfer rate in plastic injection moulding process by adding various fins number in the circular cooling channel itself. The effect of cooling time and cooling efficiency was simulate by Moldex3D software. The result showed that cooling time reduced approximately by 6.5 second for the cooling channels with seven fins as compared with the cooling channels with circular cross section. The cooling efficiency in term of heat flux increased by 22.6 %. However, this study only focused on experimental mould and did not mention any actual mould applications.

Many researchers only manipulate the design layout to achieve better cooling process and have not fully optimize the ability of SFF technology to improve the geometry of the cooling channel itself. This paper presents the possibility for application of external fins design to enhance heat transfer rate in the plastic injection moulding process. Various design of fins were simulated with Moldflow Insight software to determine the shortest time to reach ejection temperature that directly affects the cycle time. A comparison of results between each SFCC design was also presented. This paper was limited to simulation study only and lacking with the experimental results, its main focus on simulation comparison with both the results these findings into conclusion.

## **Theory**

Conduction and convection are the main heat transfer phase that occurs in plastic injection moulding. The radiation can be neglected due to the very low

amount that occur in the out of the mould surface. The heat input by hot polymer melt must be removed as much as possible inside the mould before the mould can be opened to eject the part by conduction and convection process. According to the French mathematical physicist Joseph Fourier, energy transfer can be expressed by mathematical equation as follows,

$$Q_c = KA \frac{\Delta T}{L} \quad (1)$$

Where,

- Q<sub>c</sub> = thermal conductivity of the medium
- K = conduction heat transfer energy
- A = area of the core or cavity in contact with the plastic material
- ΔT = temperature difference between hot polymer material and coolant
- L = distance between two mediums

Another heat transfer phenomenon that occurs in injection moulding is the heat transfer by convection. The overall heat transfer by convection can be expressed by Newton's law by the following equation [12-13],

$$Q_h = hA(T_w - T_c) \quad (2)$$

Where,

- A = contact cooling channel surface area with the flowing fluid
- T<sub>w</sub> = temperature of the cooling channel wall
- T<sub>c</sub> = coolant temperature
- h = convection heat transfer coefficient

The values of T<sub>w</sub> and T<sub>c</sub> are not constant in real situations of injection molding process. Total of the heat flows in the plastic injection moulding as shown in Figure 1 can be expressed in equation (3) as follows,

$$Q = h_1 A (T_{\infty 1} - T_1) = k_1 A \frac{T_1 - T_2}{L_1} = k_2 A \frac{T_3 - T_2}{L_2} = h_2 A (T_3 - T_{\infty 2}) \quad (3)$$

The values of L are the width and A represent the area of the parts. The values of k are the conductivity coefficient and the values of h is the convection coefficient of the different parts.

## Methodology

### Design of Moulds and Cooling Channels

In this study, existing mould by Shayfull [14][15] which consisted of two plate mould with submerged gating system for the Front panel housing with dimensions of 120 mm x 80 mm x 18.75 mm and 2.5 mm thickness with a volume of 27663.64 mm<sup>3</sup> was carefully chosen as the case study part for analysis. The part, as shown in Figure 2, was selected due to its curvature shape that matches with many contemporary products.

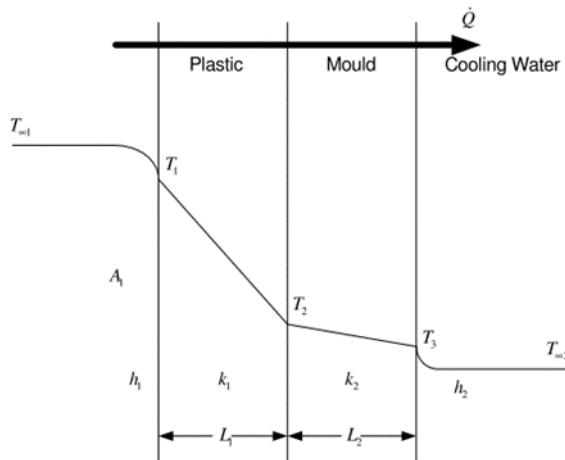

Figure 1: Heat flow direction in the plastic injection moulding tool

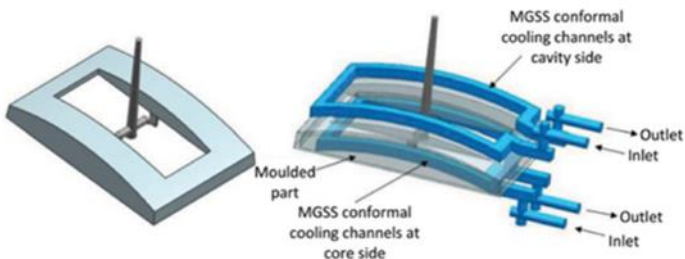

Figure 2: Milled Groove Square Shape Method (MGSS) part [14]

### Cooling system design

The cooling system is a main factor to the operation and cost of the considered mould. Possibly the reason for the lack of engineering is that the temperature distribution is not obvious when molding compared to defects related to flow [16].

The main path of cooling layout for the conformal cooling channels was follow the design in [14] and [15] was shown in Figure 3. The Square Finned Conformal Cooling Channel (SFCC) in this study was improved from previous method, Milled Groove Square Shape Method (MGSS). The MGSS was fabricated by milling process and did not use any SFF technology. SFCC design proposed in the present work complies with the manufacturability for selective laser melting (SLM) process. SLM permits to produce fully functional metal part directly from 3D data, tool less and no shape restrictions. To gain the equivalent data, the comparisons of cooling efficiency were based on the same part model, injection condition and cooling flow lines. The geometry of conformal cooling layout is remaining with MGSS design.

### Fins design

Manat et al [11] summarized that thickness and shape are basic factors to consider in fins design. There were three main shape namely triangle, trapezoid and rectangle. Their study considered the external rectangular shape because rectangular fins were able to provide more rigidity and extra surface areas than those of the trapezoid and triangle fins.

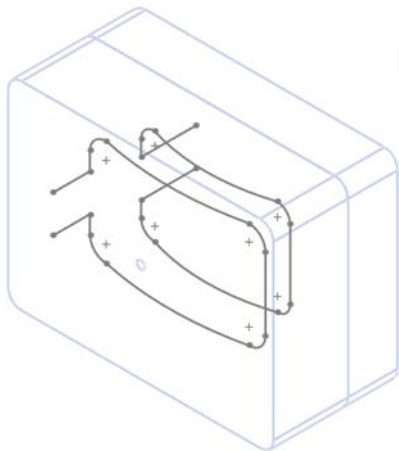

Figure 3: Profile line for Square Finned Conformal Cooling Channel (SFCC)

This study compares the square shape design in [14], [15] which was fabricated by machining process. The existing design added by various number of fins as shows in Table 1. The difference of each design is the pin number, which was increased starting from MGSS follow by design type 1 to design type 9. The fin thickness in this study was constant at 1 mm wide and 1 mm length, while the distance between the fins is 2 mm between center to center of the fins. The existing design was set as a benchmark where the time to reach ejection temperature was reported 10.55 seconds. The addition of various numbers of internal fins gave different value of time to reach ejection.

In this study the SFCC was considered as tubes with rough surface due to the surface roughness value is between  $2.28\mu\text{m}$  to  $9.20\mu\text{m}$  [17]. Tubes that with rough surface have much higher heat transfer coefficients than tubes with smooth surface. Therefore, tube surfaces are often intentionally finned, roughened or corrugated in order to enhanced the convection heat transfer coefficient and thus the convection heat transfer rate [18].













Figure 4: Tube surface (a) finned surface and (b) roughened [18]

### Simulation Setup

Firstly, the 3D model for SFCC was designed using Solidworks software. The simulation of plastic injection process was analyzed using Autodesk Moldflow Insight to get the result for the time to reach ejection part. The lowest ejection time will reduce the cycle time in production and hence improve the productivity. Next all the 3D model of part, runner system, cooling profile, core and cavity were meshed to tetrahedron mesh type as shown in Figure 3. The plastic material is ABS Toyolac 700-314 manufactured by Toray Industries Inc., Tokyo, Japan, was used in this analysis and the mould material P20 steel was selected. Normal water was set at  $25^{\circ}\text{C}$  as coolant. The function of coolant is to absorb the heat from the molten plastic and it flows out through the SFCC. For increasing the cooling efficiency, the temperature difference between inlet and outlet of the coolant and mould should be balanced by a difference of  $5^{\circ}\text{C}$  [19]. Cooling efficiency can be achieved with appropriately sized cooling channels, appropriate coolant temperature and appropriate Reynolds number for the coolant [15]. The melt and ejection temperatures for the plastic material used

are recommended by the material manufacturer and are available in the AMI software. Table 2 shows the parameter setting for the simulation process.

Table 1: Number of fins, surface area value and ejection time for SFCC

Design type	Cross sectional view	Area (mm)	Perimeter (mm)
MGSS		36	24
1		35	26
2		34	28
3		33	30
4		32	32
5		32	32
6		30	36
7		28	40
8		28	40
9		25.3	41.7



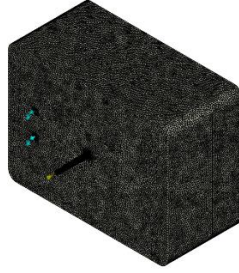

Figure 3: Completed tetrahedron mesh for simulation model.

Table 2: Process parameters for simulation

Melt temperature, °C	240
Coolant temperature, °C	25
Mold surface temperature, °C	40
Ejection temperature, °C	80
Packing Pressure, Mpa	80
Coolant flow rate, lit/min	10

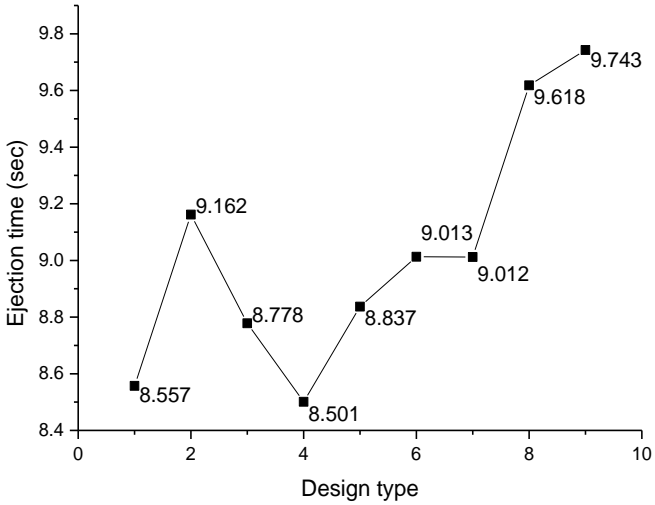
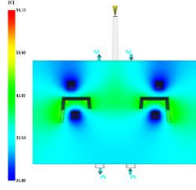
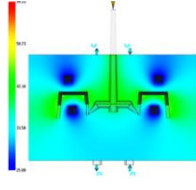
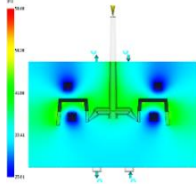
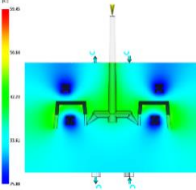
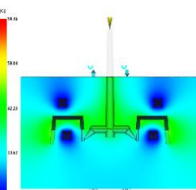
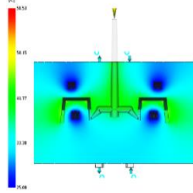
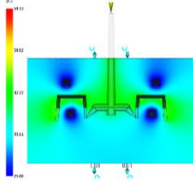
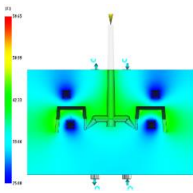
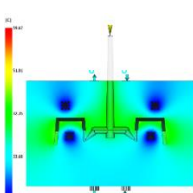
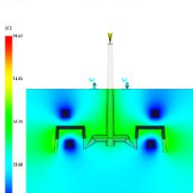

Figure 4: Time to reach ejection temperature for each design

Table 3: Average of mould temperature.

Design numbers	Mold Temperature (average)	Minimum (°C)	Maximum (°C)	Mould Temperature Distributions (°C)
MGSS		25	59.13	34.13
1		25	59.31	34.31
2		25.01	58.6	33.59
3		25	59.45	34.45
4		25	59.46	34.46

5		25	58.53	33.53
6		25	59.43	34.43
7		25	59.65	34.63
8		25	59.67	34.67
9		25	58.91	33.91

## Results and Discussion

The simulations result in Table 3 shows the mould temperature average in core and cavity of mould insert. For the existing MGSS design, the temperature was in the range of 25 °C to 59.13 °C with different 34.13°C different. While for the Design 1 that with one fins shows different in

34.31°C, for Design 2 difference in 33.59°C. The others temperature difference are 34.45°C for Design 3, 34.46°C for Design 4, 33.53°C for Design 5, 34.43°C for Design 6, 34.63°C for Design 7, 34.67°C for Design 8, 33.68°C for Design 9 and 33.91°C for Design 10. The overall temperature difference is between 33.59°C and 34.67°C where the different only show about 1°C different between the highest and the lowest value of temperature distributions. This is indicated that the internal fins have less effect to the temperature distribution but the closeness of cooling channels to the heat source will significantly affect the temperature distribution in injection moulding process. This was agree with previous research such [14], [15], [20]–[22] where the cooling channel layout will significantly affect the temperature distributions.

Figure 4 demonstrate the relationship between time to reach ejection temperature to the number of internal fins that varies by different design profile. The time to reach ejection temperate is relate to the cooling time and total cycle time in the plastic injection moulding process. The ejection time was the estimated time of the part cooled down from melting temperature to the temperature lower than the ejection temperature of plastic material. The lowest time to reach ejection temperate was recorded with 8.50 second value at Design 4 which this design has 4 internal fins. While the highest value was indicated at Design 10 with 9.74 second to reach the ejection temperature. The overall value shows the time to reach ejection temperature was decrease starting from Design 1 to Design 10 but not in consistent trend. However, the lowest value for time to reach ejection temperature in Design 4 was acceptable due to the geometry balance and symmetric in the profile compare to other design that not symmetry and unable to give the balance flow for the coolant flow. The more numbers of fins are technically will give smaller ejection time due to the higher velocity that can be generate in cooling channel. Though, the result shows the higher channel velocity in Design 9 not supposedly contribute to the lowers value for ejection time. The coolant flow may be congested due to much number of fins.

## **Conclusion**

The internal fins are one of passive heat transfer technique that not require external power to sustain the process. From the simulation results the addition of fins will affect the ejection time. However, the highest number of fins are not supposed to contribute to the lowest value of ejection time. For this study, 4 fins is the best design to enhance the heat transfer rate. The adding of fins will increase the cooling channel perimeter and contact surface area due to the heat convection principle. The fins also interrupted the flow of coolant fluid (water) that make the flow turbulence whereas the turbulence flow will increase the heat transfer rate. Hence, the SFCC with 4 internal fins

was able to dissipate the heat from molten plastic better than MGSS from the previous study that without fins. Author is working on the research that introduces the internal fins in the plastic injection moulding. The addition of internal fins is a potential method that can be applied in plastic injection moulding design that is supposed to be valuable and beneficial to the industries.

## References

- [1] J. C. Lin, "Optimum cooling system design of a free-form injection mold using an abductive network", *J. Mater. Process. Technol.*, vol. 120, no. 1–3, pp. 226–236, 2002.
- [2] H. Hassan, N. Regnier, C. Lebot, C. Pujos, and G. Defaye, "Effect of cooling system on the polymer temperature and solidification during injection molding", *Appl. Therm. Eng.*, vol. 29, no. 8, pp. 1786–1791, 2009.
- [3] A. B. M. Saifullah, S. H. Masood, and I. Sbarski, "Thermal-structural analysis of bi-metallic conformal cooling for injection moulds", *Int. J. Adv. Manuf. Technol.*, vol. 62, no. 1–4, pp. 123–133, 2012.
- [4] H. Rees, *Mold engineering*. Hanser Verlag, 2002.
- [5] S. H. Tang, Y. J. Tan, S. M. Sapuan, S. Sulaiman, N. Ismail, and R. Samin, "The use of Taguchi method in the design of plastic injection mould for reducing warpage", *J. Mater. Process. Technol.*, vol. 182, no. 1, pp. 418–426, 2007.
- [6] E. Sachs, E. Wylonis, S. Allen, M. Cima, and H. Guo, "Production of injection molding tooling with conformal cooling channels using the three dimensional printing process", *Polym. Eng. Sci.*, vol. 40, no. 5, pp. 1232–1247, 2000.
- [7] S. Mayer, Whitepaper: "Optimised mould temperature control procedure using DMLS".
- [8] S. Liu and M. Sakr, "A comprehensive review on passive heat transfer enhancements in pipe exchangers", *Renew. Sustain. Energy Rev.*, vol. 19, pp. 64–81, 2013.
- [9] H. Hassan, N. Regnier, C. Le Bot, and G. Defaye, "3D study of cooling system effect on the heat transfer during polymer injection molding", *Int. J. Therm. Sci.*, vol. 49, no. 1, pp. 161–169, 2010.
- [10] K. Altaf, A. M. A. Rani, and V. R. Raghavan, "Fabrication of circular and Profiled Conformal Cooling Channels in aluminum filled epoxy injection mould tools", *2011 Natl. Postgrad. Conf. - Energy Sustain. Explor. Innov. Minds, NPC 2011*, pp. 1–4, 2011.
- [11] M. Hearunyakij, S. Sontikaew, and D. Sriprapai, "Improvement in the cooling performance of conformal mold cooling by using fin concept", *Int. J. Mining, Metall. Mech. Eng.*, vol. 2, no. 2, pp. 41–46, 2014.
- [12] J. P. Holman, Heat Transfer, *Heat Transf.*, pp. 139–215, 2010.

- [13] R. W. Serth and T. G. Lestina, *Process Heat Transfer*. 2014.
- [14] Z. Shayfull, S. Sharif, A. MohdZain, R. MohdSaad, and M. a. Fairuz, "Milled groove square shape conformal cooling channels in injection moulding process", *Mater. Manuf. Process.*, vol. 28, no. 8, pp. 884–891, 2013.
- [15] S.Z.A.B.D. Rahim, S. Sharif, A. M. Zain, S. M. Nasir, and R. Mohd Saad, "Improving the quality and productivity of molded parts with a new design of conformal cooling channels for the injection molding process", *Adv. Polym. Technol.*, 2015.
- [16] D. O. Kazmer, *Injection mold design engineering*. Carl Hanser Verlag GmbH Co KG, 2012.
- [17] K. Kamarudin, M. S. Wahab, Z. Shayfull, A. Ahmed, and A. A. Raus, "Dimensional accuracy and surface roughness analysis for AlSi10Mg produced by Selective Laser Melting (SLM)", vol. 1077, 2016.
- [18] Y. A. Cengel, Heat and Mass Transfer: A Practical Approach, 3rd Edition, in *Medical engineering & physics*, vol. 32, 2007, pp. 408–416.
- [19] D. Kazmer, *Injection Mold Design Engineering*. 2007.
- [20] A. B. M. Saifullah and S. H. Masood, "Cycle time reduction in injection moulding with conformal cooling channels", in *Conference Proceedings of the International Conference on Mechanical Engineering*, 2007, pp. 29–31.
- [21] X.-P. Dang and H.-S. Park, "Design of U-shape milled groove conformal cooling channels for plastic injection mold", *Int. J. Precis. Eng. Manuf.*, vol. 12, no. 1, pp. 73–84, 2011.
- [22] D. E. Dimla, M. Camilotto, and F. Miani, "Design and optimisation of conformal cooling channels in injection moulding tools", *J. Mater. Process. Technol.*, vol. 164–165, pp. 1294–1300, 2005.