

Performance Evaluation of Dynamic Absorbers Based on Randy Fox and Dunkerley Methods

Syafirah A. Samat, A.A. Mat Isa, and M. Azhan Anuar*
Faculty of Mechanical Engineering, Universiti Teknologi
MARA, 40450 Selangor, Malaysia

*azhan788@salam.uitm.edu.my

ABSTRACT

Dynamic Absorber (DA) application is the method used to avoid resonance in a vibrating system. In practice, many types of DA are utilized such as active and passive DA and it depends on the cost and environmental conditions. Designers/ engineers select DA parameters and model the absorber before it is implemented and tested to the main system. Hence, it will be beneficial to have tools or templates for fast and effective selection of DA. This paper will discuss the selection parameters of a passive DA based on templates derived from Dunkerley Method (DM) and Randy Fox Method (RFM) and its accuracy is verified experimentally. It is observed that in this case, DA has reduced the vibration amplitude significantly. Furthermore, the results show the RFM absorber has performed better than the DM absorber. This study enables verification of the effectiveness of DA to tackle resonant problems. In the future, these GUI templates could be helpful for industrial application with vibrating problems.

Keywords: *Dynamic absorber; Dunkerley method; Randy Fox method; Graphic User Interface; Operational Modal Analysis*

Introduction

Dynamic absorber (DA) is a mechanical device used to tackle unwanted vibration resonance within the operational frequency of the system. It consists of additional mass and stiffness and attached to the existing main mass system. On the other hand, dynamic absorber also can be acknowledged

as an auxiliary system. With the additional of dynamic absorber, the system becomes a two-degree-of-freedom system, thus, it will produce two natural frequencies. In practice, DA is applied under the condition when the natural frequency of the dynamic absorber is tuned to be similar to the excitation frequency [1]. The dynamic absorber works effectively when the excitation frequency is close or similar to the natural frequency of the main system.

The first dynamic absorber was introduced by Frahm in 1909 and since that, various methods have been developed for DA especially for mechanical [2]–[4] and civil structure [5]–[7] applications. The design parameters of DA are determined from the theoretical and mathematical modelling. It is important to get a good understanding on the dynamical behaviours of the parameters obtained and optimization could be done to reach the design decision [8].

An effective DA must be designed with proper mass ratio and spring in order to have sufficient strength to absorb the energy of a main system [9]. An increase in mass ratio results in diminishing response of the main system. It was found that a large absorber mass is required to wider apart the natural frequencies [10]. However, larger absorber mass is highly impractical especially for large machinery. Hence, the design of the DA depends on the application required and its suitability. In addition, the applicability of DA really need to be observed since the selection of tune mass and its location is required from an experience designers/engineers.

Therefore, in this study, a GUI templates are constructed from analytical derivation of dynamic absorber using DM and RFM to assist the design process to select the parameters that are required. Based on the obtained resonance frequency from Operational Modal Analysis (OMA), these templates are used to select the appropriate parameters to fabricate the DA of both methods. In order to evaluate the performance and effectiveness of these methods, an experimental setup was conducted to measure the deflection of the main system.

Dunkerley Method (DM) and Randy Fox Method (RFM)

In this study, the templates are developed using DM and RFM and the derivation are made to determine the parameters needed for the Dynamic Absorber (DA).

The natural frequency of an effective mass (ω_1) of DM dynamic absorber is derived using Uniform Beam (transverse and bending vibrations) general formula [1]. Given the formula for cantilever beam is,

$$\omega_n = a_n \sqrt{\frac{EI}{\mu L^4}} \quad (1)$$

where,

$$\mu_1 = \frac{m}{l} \text{ (Assuming } l=1)$$

a_n = Numerical constant

E = Modulus of elasticity (GPa)

L = Bar length (m)

$$I = \text{Area moment of inertia for rectangular cross section} = \frac{bh^3}{12} \text{ (m}^4)$$

By using beam equation, natural frequency of effective mass of dynamic absorber is derived as below. Assuming numerical method (a) in mode shape 1, thus $a_1 = 3.52$

$$\omega_1 = 3.52 \sqrt{\frac{EI}{\left(\frac{m_1}{l}\right)L^4}} \tag{2}$$

$$\omega_1^2 = 12.3904 \left(\frac{EI}{m_1L^4}\right)$$

Using the Dunkerley's formula, yields

$$\frac{1}{N_f^2} = \frac{1}{12.3904 \left(\frac{EI}{m_1L^4}\right)} + \frac{1}{\left(\frac{3EI}{m_2a^3}\right)} \tag{3}$$

$$\frac{1}{N_f^2} = \frac{m_1L^4}{12.3904EI} + \frac{m_2a^3}{3EI}$$

Rearrange equation (3) and the final equation to determine the amount of tune mass (m_2) for DM method is,

$$m_2 = \frac{3EI}{N_f^2 a^3} - \frac{0.242123m_1L^4}{a^3} \tag{4}$$

On the other hand, for RFM method, the analytical derivation for tune mass (m_2) is taken directly from RFM derivation [11]. The amount of tune mass (m_2) of Randy Fox method is given by,

$$m_2 = \frac{(2.115 \times 10^5)EI}{N_f^2 (3a^2L - a^3)} - \frac{0.75m_1L^4}{3a^2L - a^3} \quad (5)$$

Figure 1: Auxiliary system as a dynamic absorber system [13].

Equation (4) and Equation (5) indicate the amount of tune mass (m_2) needed at a specified distance (a) on a piece of flat or rectangular bar stock of length (L), having cross-sectional dimensions of (b) and (h) to achieve the desired natural frequency (N_f).

Methodology and Experimental Set-up

An experimental main system (Figure 1) was fabricated to test the performance of both RFM and DM dynamic absorber (Figure 2). The main system was experimentally tested using OMA setup and the results obtained are useful to select the target/resonance frequency and applied in the GUI templates to design the absorbers.

The GUI templates were used to facilitate efficient selection of the dynamic absorber parameters. Since both DM and RFM have different analytical equations, two GUI templates were constructed (Figure 3 and Figure 4). Dynamic absorber consists of stainless steel bar, mild steel blocks and a tune mass (m_2) which is measured as 0.34 kg. Three holes drilled on the stainless steel bar indicate the effective distance of tune mass (a). Using bolts and nuts, the dynamic absorber is mounted to the main system at point P_1 .

These templates help to calculate the amount of tune mass (m_2) needed at a specified distance (a) on a piece of flat or rectangular bar stock of length (L), having cross-sectional dimensions of (b) and (h) to achieve the desired natural frequency (N_f). It is required to fill up the values of all parameters and the results will be calculated automatically once with a single clicks in the output section.

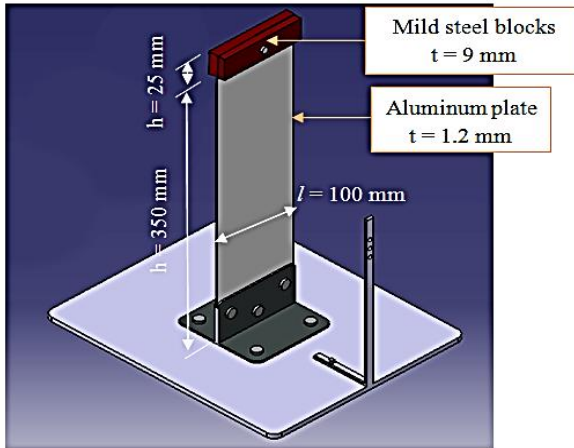

Figure 1: Main system

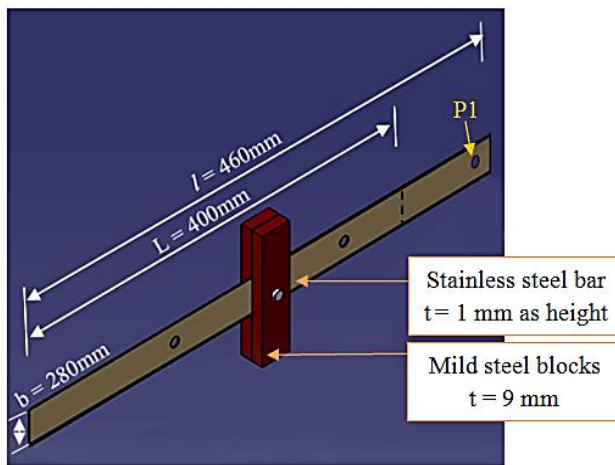

Figure 2: Dynamic absorber system

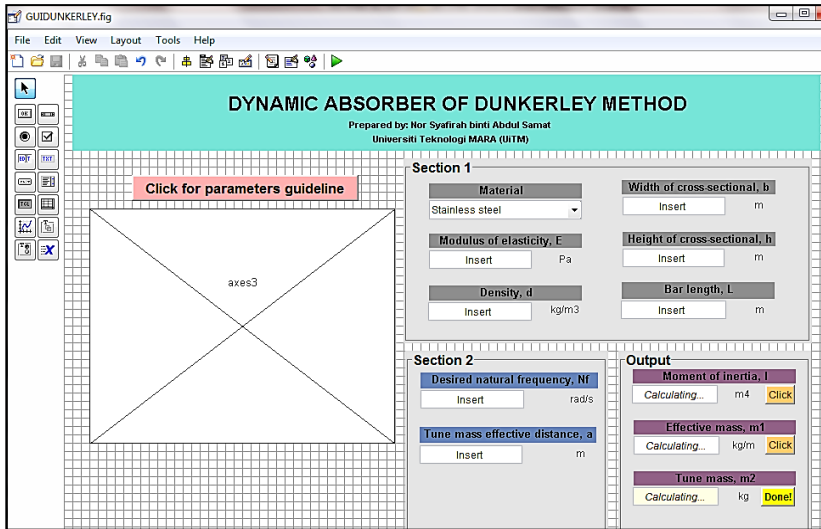

Figure 3: GUI template for DM

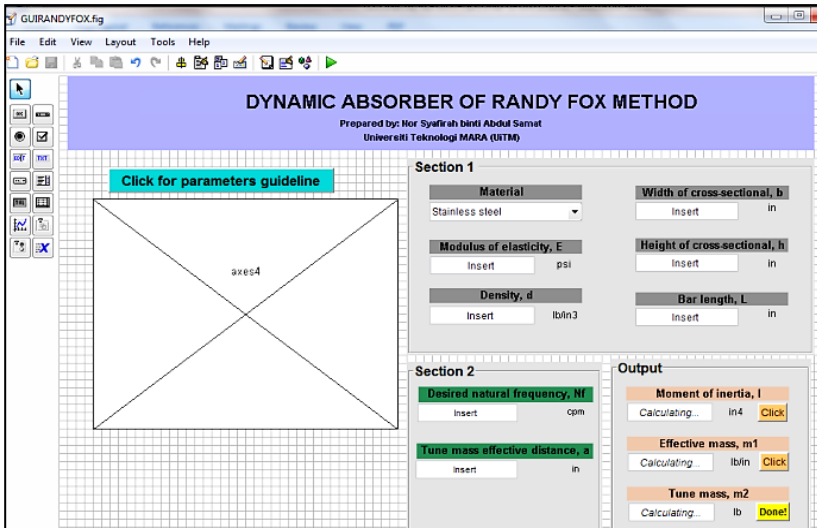

Figure 4: GUI template for RFM

To evaluate the effective and performance of both methods (i.e. DM and RFM) the main system was excited at the resonance frequency. Previously, the main system was tested experimentally using Operational Modal Analysis and the FRF magnitude shows that the first resonant peak was observed at 2 Hz. Hence, an excitation frequency of 2 Hz is selected in this study to make sure the main system is at resonance condition, and the deflection (x) of the main system with and without dynamic absorber will be observed. To excite the test structure, VTS Shaker – 100 together with the sweep function generator and amplifier model 5530 are used.

The deflection of the test structure was recorded by using high-speed camera Olympus i-Speed 2 and Controller Display Unit (CDU) in slow motion processing. This camera only provides black and white colour processing. Thus, a good lighting from the spotlight is very important during the experimental setup (as shown in Figure 5 and Figure 6).

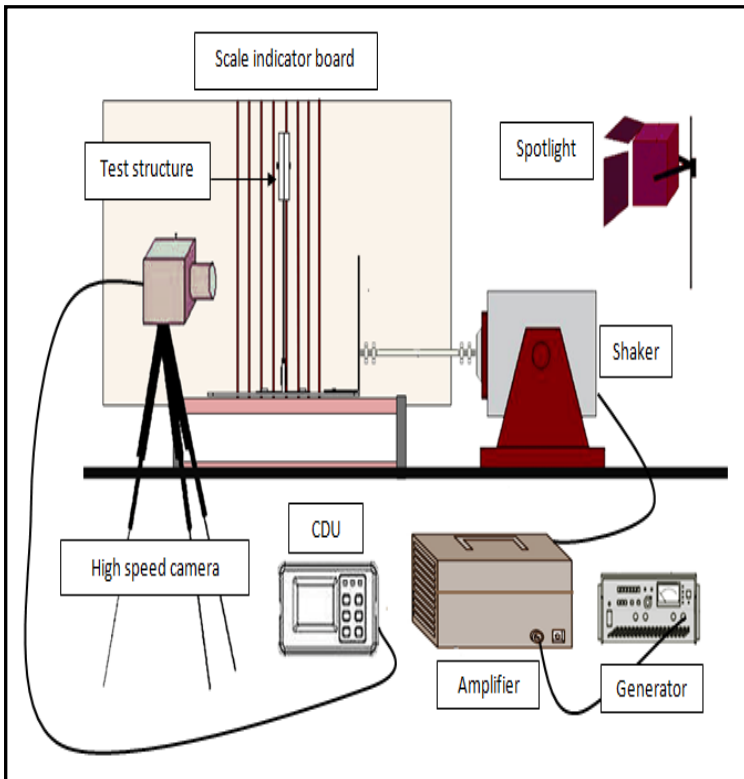

Figure 5: Schematic diagram of the experimental setup

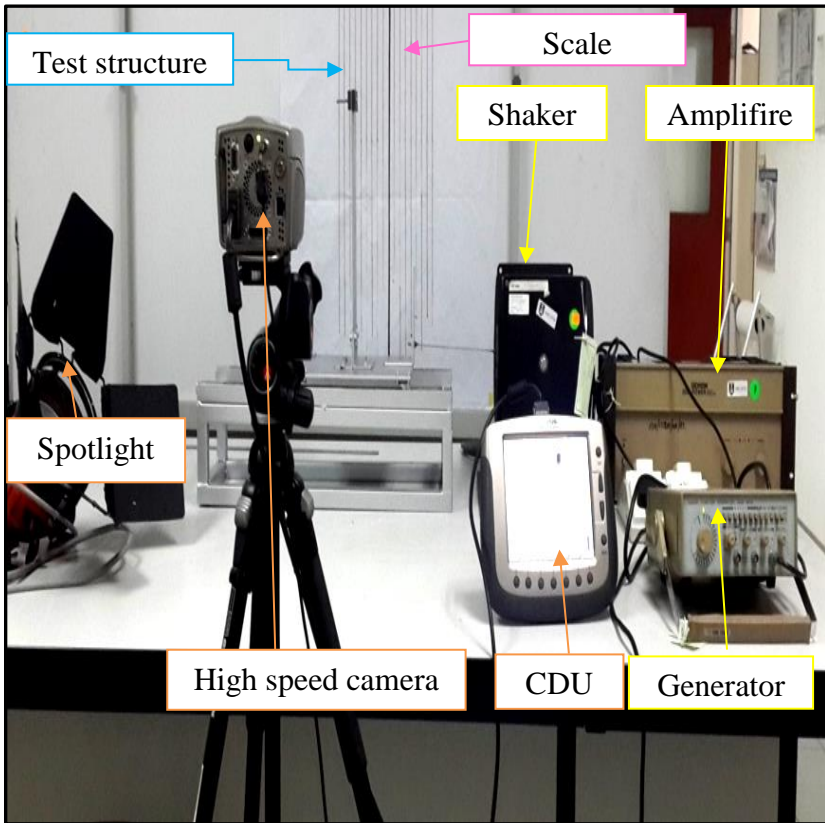

Figure 6: The arrangement of the experimental setup

The test structure is placed in front of the scale indicator board. Vertical line indicators with scale of 0.02 m apart were drawn on the scale indicator board. A darker vertical line at the centre is used as a reference for deflection analysis. Every measurement was obtained within specific 20 seconds recording duration. Two sets of excitation frequency are selected for this experiment, which are,

- I. 2 Hz is selected based on the targeted natural frequency of the main system to excite resonance.
- II. 3 Hz is selected as an additional analysis to compare further the effectiveness of both methods.

This study also interested to compare the effectiveness of dynamic absorber with different positions of tune mass. Hence, the experimental setup was arranged based on different conditions and tune mass positions as tabled in Table 1.

Table 1: The arrangement of experimental set up

Excitation frequency (Hz)	Condition	Position of tune mass
2	The main system only	-
2	The main system with DM dynamic absorber	Horizontal
2	The main system with DM dynamic absorber	Vertical
2	The main system with RFM dynamic absorber	Horizontal
2	The main system with RFM dynamic absorber	Vertical
3	The main system with DM dynamic absorber	Horizontal
3	The main system with DM dynamic absorber	Vertical
3	The main system with RFM dynamic absorber	Horizontal
3	The main system with RFM dynamic absorber	Vertical

Results and Discussions

Initially, the deflection of the main system without DA is recorded. Measurement was taken when the motion of the main system reached the maximum deflection as observed from scale indicator board. The test structure is excited at 2 Hz and it was observed that the main system vibrates excessively due to resonance. As shown on Figure 8, the deflection of the system reached maximum displacement of 0.130 m.

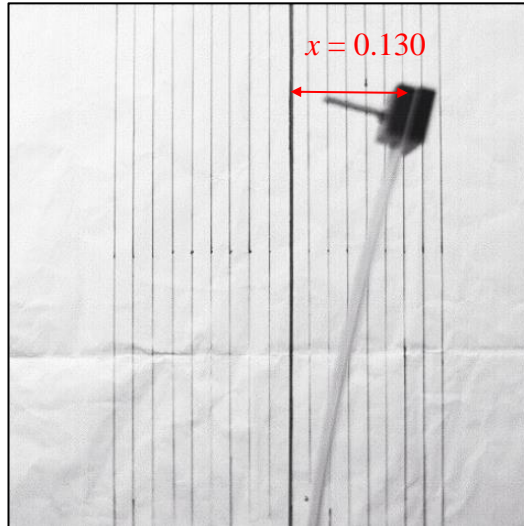

Figure 8: Maximum deflection of the main system without dynamic absorber

Since the main system was dominated by natural frequencies of 2 Hz and 16 Hz, this study only focuses on designing the dynamic absorber of DM and RFM at 2 Hz. The parameters of dynamic absorber depend on the targeted natural frequency and using GUI templates, the reasonable parameters of dynamic absorber are determined. In this study, every parameter involves in dynamic absorber design is constant except for the specified distance of tune mass (a).

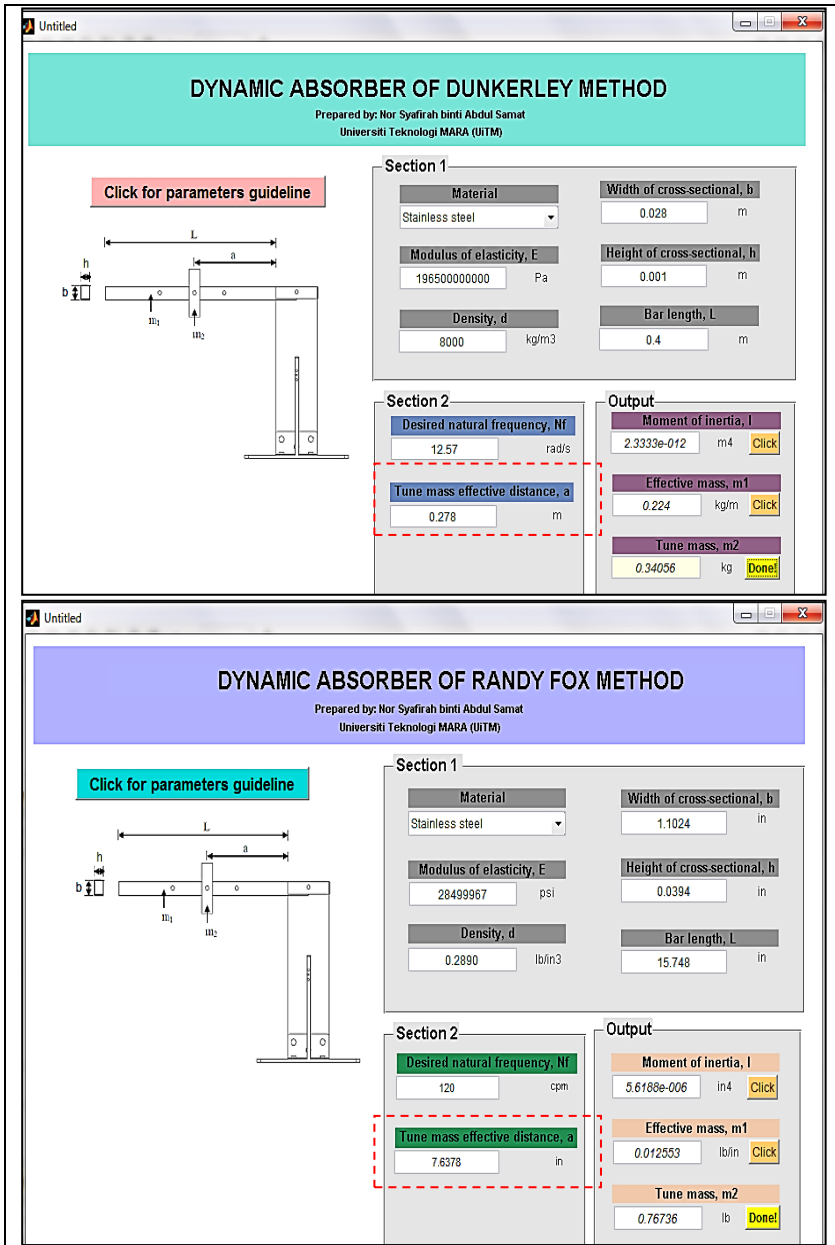

Figure 9: Selection parameters of DM and RFM dynamic absorber at 2 Hz

Based Figure 9, the specified distance of the tune mass for both methods is dissimilar, even if the same amount of tune mass is used. The parameters of dynamic absorber at 3 Hz are also extracted from the templates to study further the effect of both DA on the main system. It turns out the specified distance of tune mass for RFM absorber at 2 Hz is similar with DM absorber at 3 Hz. Thus, both dynamic absorbers can be tested at the same specified distance of 0.194 m. The overall values of specified distance of tune mass are shown in the Table 2 below.

Table 2: The specified distance of the tune mass at desired natural frequency

Excitation frequency (Hz)	Specified distance of tune mass, a (m)	
	DM	RFM
2	0.278	0.194
3	0.194	0.124

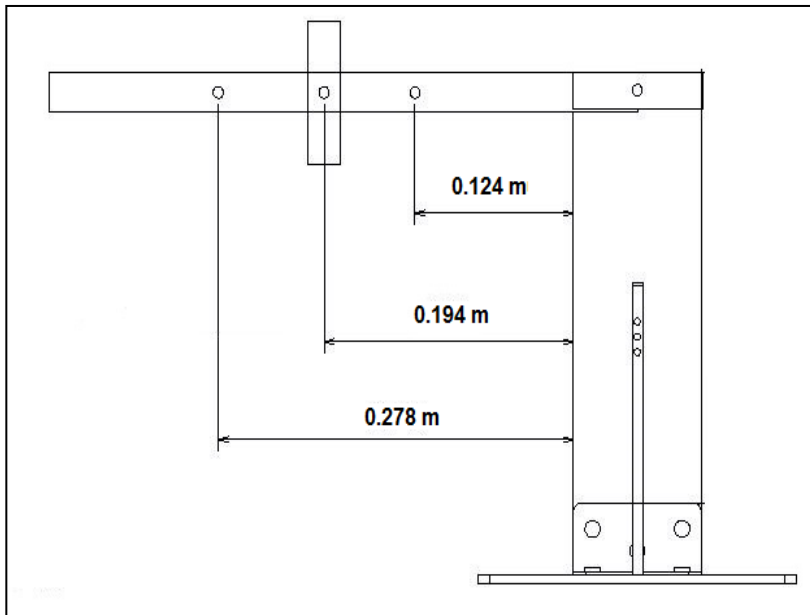

Figure 10: Illustration of the tune mass position at the identified distance

Since the excitation frequency of 3 Hz is quite close to 2 Hz, the outcome is somewhat counterintuitive. The deflection of the main system is observed and measured to compare the effectiveness and performance of

RFM and DM absorbers. Table 3 and Table 4 show the comparison of dynamic absorber performance for different conditions where the deflection and percentage different are determined. It was found that both dynamic absorbers reduced the deflection of the vibrating main system. At 3 Hz excitation as in Table 4, the reference measurement was not taken (condition for the main system only without dynamic absorber) since the purpose of this applied excitation is mainly to study the further effect of absorber to the deflection.

It can be seen that RFM dynamic absorber has produced higher percentage of displacement reduction as compared to DM dynamic absorber for all setup. At resonance condition as in Figure 11 (excited at 2 Hz), the best deflection is obtained from horizontal position of RFM dynamic absorber. The deflection is reduced to 0.04m which is about 69.23%. The experiment was repeated at an excitation frequency of 3 Hz and again in this case, the RFM dynamic absorber in horizontal position produced the best result for deflection reduction as shown in Figure 12.

Arrangement positions of the tune mass demonstrate dissimilar performance of both DA. For both excitation setup, RFM dynamic absorber at 2 Hz gave better performance compared to DM dynamic absorber at 3 Hz in horizontal position while in vertical position, the RFM absorber deflects more than the DM absorber. Overall, it was found that for this case study, the effectiveness of RFM dynamic absorber is high compared to DM dynamic absorber. In terms of tune mass positioning, the tune mass in horizontal position is the best position for this experimental setup.

Table 3: Displacement and percentage reduction of deflection at 2 Hz

Condition	Position of tune mass			
	Horizontal		Vertical	
	Deflection, x (m)	Reduction (%)	Deflection, x (m)	Reduction (%)
Main system without dynamic absorber	0.130	reference	0.130	reference
Main system with DM dynamic absorber	0.096	26.15	0.089	31.54
Main system with RFM dynamic absorber	0.040	69.23	0.079	39.23

RFM
dynamic
absorber

Table 4: Displacement and percentage reduction of deflection at 3 Hz

Condition	Position of tune mass	
	Horizontal	Vertical
	Deflection, x (m)	Deflection, x (m)
Main system with DM dynamic absorber	0.051	0.064
Main system with RFM dynamic absorber	0.026	0.040

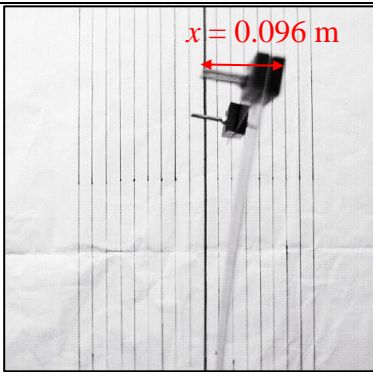

Figure 11(a): DM dynamic absorber in horizontal position

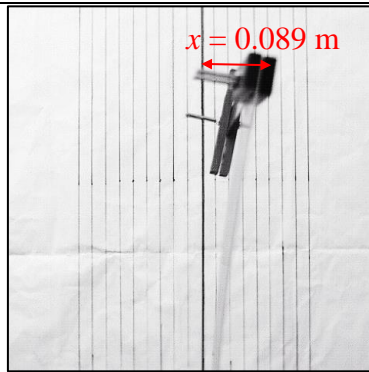

Figure 11(b): DM dynamic absorber in vertical position

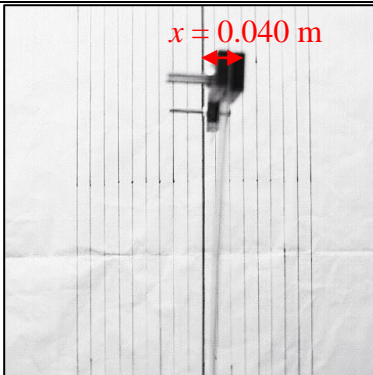

Figure 11(c): RFM dynamic

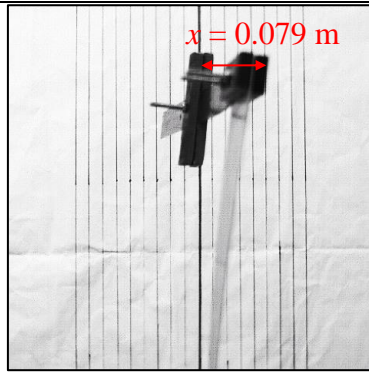

Figure 11(d): RFM dynamic

absorber in horizontal position	absorber in vertical position
---------------------------------	-------------------------------

Figure 11: Deflection of the main system with DA at an excitation frequency of 2 Hz.

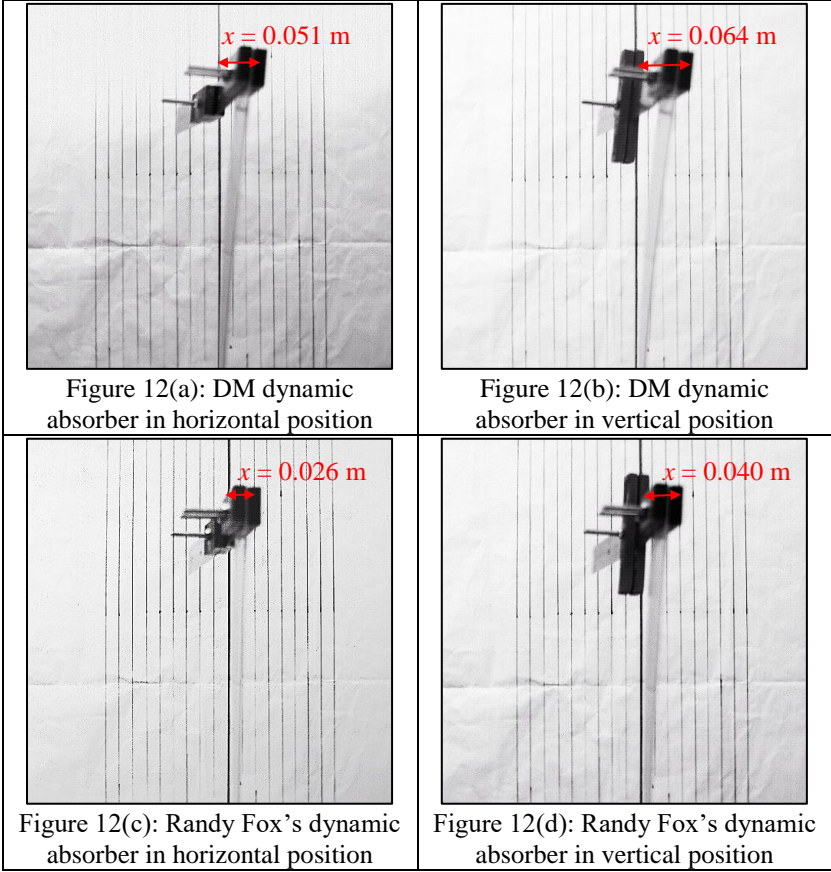

Figure 12: Deflection of the main system with DA at an excitation frequency of 3 Hz.

Conclusion

The suitable parameters for Dynamic Absorber (DA) have been obtained using GUI templates of DM and RFM method. Two different excitation setup were applied in the experiment to test the performance of DA and its

effectiveness was studied. Reliability of the result depends on the method of designing dynamic absorber and the way tune mass was arranged. Both absorbers reduced the deflection of the main system significantly and for this study, the RFM dynamic absorber is more effective compared to DM dynamic absorber.

In the future, continuous efforts may be needed for the improvement of the experimental setup. It is beneficial if the main system is designed with capability to withstand a wide range of excitation frequencies. In addition, since the understanding of DA behaviours and its application provides such a valuable insight into the nature of the response and remarkable enhancement of its model, strength and vibration, it is recommended that future work using simulation, modelling and analytical analysis be accommodated in this area of interest. The GUI templates could be helpful for industries to design suitable dynamic absorber for the vibrating system.

References

- [1] S. S. Rao, *Mechanical Vibrations*, 6th ed. Pearson Prentice Hall, 2016.
- [2] Y. Khazanov, "Dynamic Vibration Absorbers – Application with Variable Speed Machines," Northbrook, 2007.
- [3] L. Liu and W. Shao, "Design and Dynamic Response Analysis of Rail with Constrained Damped Dynamic Vibration Absorber," *Procedia Eng.*, vol. 15, pp. 4983–4987, 2011.
- [4] M. Orečný, Š. Segľa, R. Huňady, and Ž. Ferková, "Application of a Magneto-rheological Damper and a Dynamic Absorber for a Suspension of a Working Machine Seat," *Procedia Eng.*, vol. 96, pp. 338–344, 2014.
- [5] N. Debnath, A. Dutta, and S. K. Deb, "Multi-modal Passive-vibration Control of Bridges under General Loading-condition," *Procedia Eng.*, vol. 144, pp. 264–273, 2016.
- [6] T. Zhichang and Q. Jiaru, "Roof Isolation System - A Vibration Absorber for Buildings *," vol. 6, no. 5, pp. 446–452, 2001.
- [7] H. O. Ozer and N. Yagiz, "Dynamic absorber design for experimental two storey building model," in *AIP Conference Proceedings*, 2012, vol. 1479, no. 1, pp. 1911–1914.
- [8] A. Z. Pachpute and P. B. Bawa, "Optimum Design of Damped Dynamic Vibration Absorber – A Simulation Approach," *Int. J. Recent Eng. Res. Dev.*, vol. 1, no. 2, pp. 19–21, 2016.
- [9] R. Smith, "Dynamic Vibration Absorbers," *Sound Vib.*, vol. 32, no. 11, pp. 24–27, 1998.
- [10] Y. Khazanov, "Dynamic Vibration Absorbers - Application with Variable Speed Machines," 2007.

- [11]R. Fox, “Dynamic Absorbers for Solving Resonance Problems,” *Entek IRD International Corp*, Houston, pp. 1–14.