

Research Paper

Open Access

Lisa Lenz, Kai Christian Weist, Marvin Hoepfner, Panagiotis Spyridis* and Mike Gralla

Symbiosis of life-cycle structural design and asset management based on Building Information Modeling: Application for industrial facility equipment

DOI 10.2478/otmcj-2020-0013

Received November 15, 2019; accepted February 10, 2020

Abstract: In the last few years, particular focus has been devoted to the life cycle performance of fastening systems, which is reflected in increasing numbers of publications, standards and large-scale research efforts. Simultaneously, experience shows that in many cases, where fastening systems are implemented – such as industrial facilities – the design of fasteners is governed by fatigue loading under dynamic characteristics. In order to perform an adequate design and to specify the most efficient and appropriate fastening product, the engineer needs to access and process a broad range of technical and commercial information. Building information modelling (BIM), as a data management method in the construction industry, can supply such information and accommodate a comprehensive design and specification process. Furthermore, the application of BIM-based processes, such as the generation of a BIM-model, allows to use the important information for the construction as well as the life cycle management with different actions and time dependencies of the asset and its components. As a consequence, the BIM model offers the potential to correlate different data relevant for achieving the goals of the respective application, in order to ensure a more effective and correct design of the fastening. This paper demonstrates such a BIM-based design framework for an Industry 4.0 case, and in particular, the installation of a factory robot through post-installed anchors under fatigue-relevant loading in concrete.

*Corresponding author: Panagiotis Spyridis, Faculty of Architecture and Civil Engineering, TU Dortmund University, Dortmund, Germany, E-mail: panagiotis.spyridis@tu-dortmund.de

Lisa Lenz, Kai Christian Weist and Mike Gralla, Chair of Construction Management, Faculty of Architecture and Civil Engineering, TU Dortmund University, Dortmund, Germany

Marvin Hoepfner, Chair of Fastening Engineering, Faculty of Architecture and Civil Engineering, TU Dortmund University, Dortmund, Germany

Keywords: building information modelling, fastening systems, fatigue loading, Industry 4.0, lifecycle design

1 Introduction

Building information modelling (BIM) is vividly gaining scope of application in the construction industry, which is evident in numerous publications of academic studies, case studies, national and industry standards and dedicated technical events. BIM presents a variety of benefits in several aspects of infrastructure engineering, most eminently with respect to project coordination during the planning and construction phase, and the facility management during building operation. The privilege of relying on BIM for the life cycle management of technical assets is currently a focus in the discourse of digital planning and construction. In particular, archived BIM models can accommodate efficient processes for locating the component of interest, evaluating its remaining service life, assessing costs of maintenance or replacement and coordinating inspection and maintenance exercises at a project level. Modern industry currently begins to support dynamic interactions between the digital and hardware or built environment (e.g. Internet of Things (IoT) systems), based on a combination of live multidimensional BIM models connected in a network of data transfers and processing. This can also enable the introduction of monitoring equipment (e.g. sensors and/or recording devices) in the infrastructure asset under maintenance, which can automatise this procedure and drastically increase reliability and stability of the assets' life cycle performance. Recently, research in the field (Gralla and Lenz, 2017), (Lenz et al., 2019) has achieved to transfer building facility management exercises to the Industry 4.0 realm, by coupling building with factory operation datasets, thus opening the potential for further integration of various

technical and industry disciplines to multidimensional BIM objects (BIMS-US, 2019).

At the same time, connections and fastenings are a key element in the construction sector. Modern fastening technology is characterised by post-installed or cast-in-place construction products (anchors or fasteners) typically for use in structural concrete. Design considerations include building flexibility, available dimensional configurations, load-bearing capacities, assembly speed and project specifications such as thermal and noise insulation, fire resistance, environmental footprint and performance under dynamic, seismic or sustained loads (Wendner et al. 2013). As a critical and repetitively used component in construction, fasteners, as products, are required to exhibit a consistent life cycle with the respective fixture. Human errors at installation, although hard to spot, are very common in construction, while they can virtually consume the anchorage's load-bearing capacity well before the intended end of service life (Grosser et al., 2011; Cornin, 2015). Decommission of fasteners cannot be conducted without leaving a trace of damage in the anchorage area, which renders displacement of a fastener quite a challenging task. It is also easily understood that the potential damage value caused by failed fastening elements is by several orders of magnitudes higher than the value of the product itself. Recent failure incidents with disproportionate collapses and fatal public consequences (see e.g. (NTSB, 2007; Kawahara et al., 2014)) further raised significant attention to the life-cycle aspect of consequences of an unexpected loss of the entire system. For structural connections, the entire structure's design service life must be maintained also for fastenings. For attachments of technical equipment, performance of the fastening is essentially a precondition for the operation of the equipment. Highly significant attachments are those associated with human life and safety (lifeline equipment, suspended building furniture, etc.) or with a substantial economical value (such as machines or robots in factory production lines). This study focuses on this latter case, and it presents a life cycle approach of fastenings in the environment of modern automatised industry production.

In particular, this case study highlights the relevance of BIM modelling for an improved design and life cycle assessment of fastenings. The concept is presented in terms of an Industry 4.0 case study, with focus on the foundation of a robotic arm susceptible to fatigue failure. Factors significant for the short-term and fatigue design of the fastening are derived from an enhanced BIM object, where both building as well as operational data are stored (Weist, 2019). The necessary

input data are described; they are converted into compliant forms, and they are used for a structural design based on realistic actions on the fastening. Moreover, the flow of live information is used for an effective prediction of the fastening's service life, allowing for an educated maintenance strategy. In parallel, this study demonstrates a holistic use of BIM in operating Industry 4.0 components, coupling production and building management of factory assets. The concept and benefits of life cycle assessments in engineering are summarised in Figure 1.

2 Design and dimensioning of fastening systems

For the structural dimensioning of fastening systems, design procedures are carried out according to the current state of the technology. These generally include the currently valid standards and guidelines and their associated concepts of design and models. The exemplary standards EOTA ETAG 001, fib Model Code or the newly issued Eurocode for fastenings, EN 1992-4 (CEN, 2018), the applicable reference standard in Europe and largely implemented worldwide, are equivalent in the basic concept of design. The background model code (fib, 2011) is a widely accepted equivalent design guide.

The structural design can basically be classified into the two interacting categories of action and reaction, i.e. resistance and properties of the fastening system. The main influencing factors of the action, respectively the loading, which is determined by the engineer depending on the design situation, should be calculated in accordance with kinematic motion sequences and force-induced loads and can be categorised into the following points.

- mechanical action types (quasi-static action, fatigue-relevant action, seismic action, temperature, etc.);
- temporal course, values of the action and behaviour of the load;
- geometric direction of action (axial, transverse or combination of both);
- on the other side is the fastening system itself and is characterised by the properties of the individual, constructive system with the following categories:
 - fastening group or individual fastening;
 - geometry (edge distances, spacing between fasteners, fastener diameter, embedment depths, etc.);
 - materiality of fastening (concrete class, mortar, plastic sleeves, steel class, etc.) and

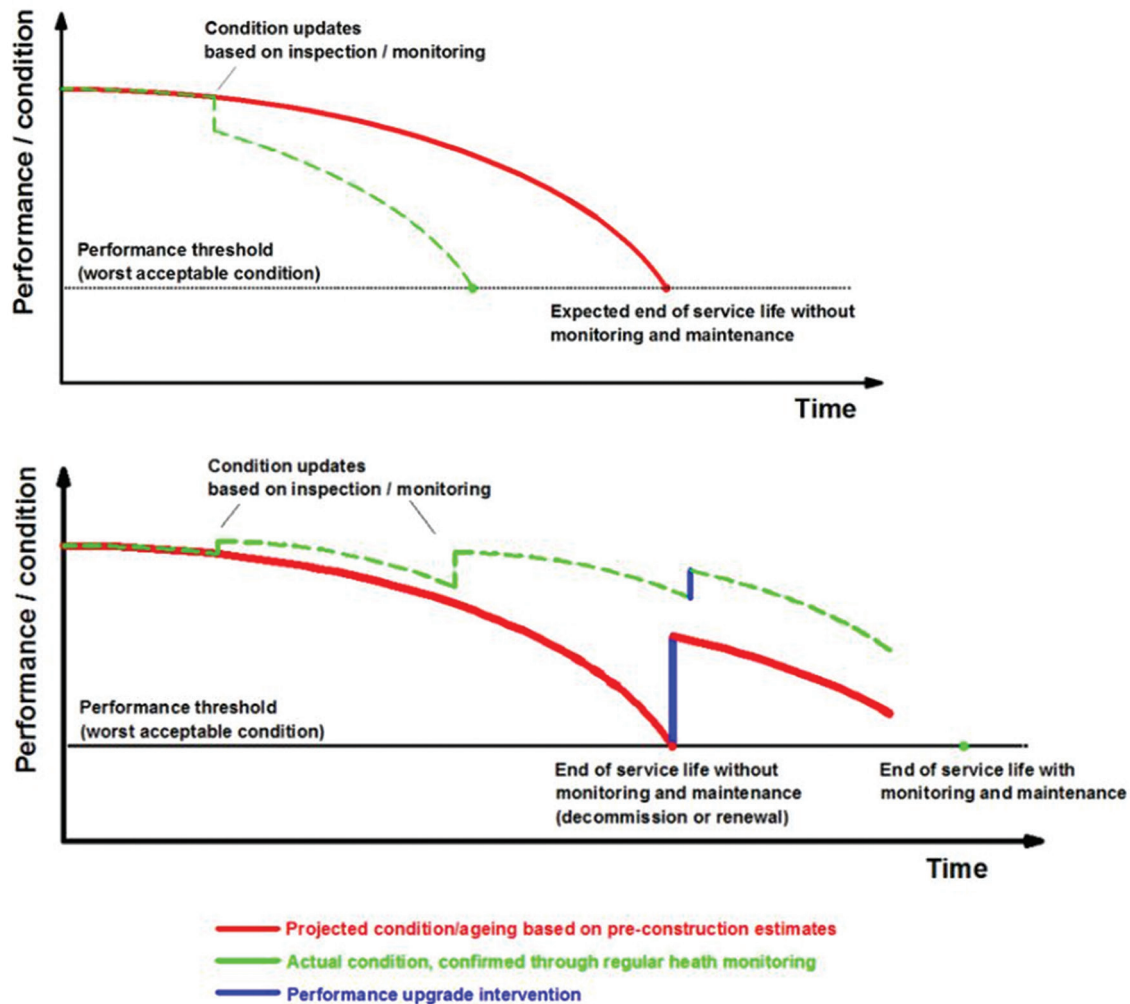

Fig. 1: Two indicative long-term performance prediction scenario, with and without data-based updates.

- mechanical resistance and load transfer mechanism (friction, bonding, mechanical interlock).

2.1 European technical assessments

The previously described characteristics of the approved fastening systems are generally contained in the valid documents, the so-called European technical assessments (ETAs). In general, an ETA always includes the system and element description with materiality and geometry, setting procedure, geometric boundary parameters and the final mechanical resistances (Scheller and Künzlen, 2013). For a successful adaptation in an automated and routine design with the support of BIM structures, corresponding equally based interfaces must be established so that software modules can capture and process the necessary semantic and quantitative information of the system for design process.

2.2 Impact of different mechanic loads

The approximation of the real, mechanical action into one (or more) specific loading types represents a fundamental and influential step in the design procedure. Thus, the mechanical actions can be divided into the following classes/types of:

- quasi-static action;
- fatigue-relevant action and
- seismic action.

The fatigue-relevant action, respective non-resting action, investigated in this study is subdivided into different categories, depending on the temporal course, whereby periodic (and harmonic) functions are generally sufficient. Above all, the identification and differentiation of fatigue-relevant loads often cause problems in practice. For example, information of small cyclic repeating movements of the fastened machine/construction is considered

as not relevant. The choice of the abstraction of the real motion and load curves also has a massive effect on the design, respectively the utilisation and economic efficiency in combination with the lifetime analysis (Block and Dreier, 2003). Especially in the case of fastening robotic machines, which can deliver an exact, three-dimensional load and force profile, the conventional approach of sinusoidal independent functions has its limits in terms of feasibility and economic efficiency. Considerations and associated calculation steps as well as the results are shown in the following capitals using the case of the fastening of a robotic machine. In general, however, a high (or full) information content of the temporal loading has to be observed, especially in case of complex, spatial movements and actions. An example of a complex movement is given in Figure 2.

2.3 Summary of influence factors on design

In general, the influencing factors of the design exist on two sides, both the action and the fastening system. However, the properties of the fastening system are usually fixed with the corresponding ETA and have practically no influence on the design. What remains is the calculation of the action to be selected by the engineer according to the design case. Since the conventional procedures have limits and a certain degree of flexibility is also possible, differentiated approximated actions and design methods can be applied, which lead to different results. In order to obtain more optimised designs, the information content of the action in the temporal sequence must have sufficient fullness and the approach of a temporal dependence of the action projections must be defined. With these approaches and software support with BIM

models, subsequent considerations of life cycle analysis for complex problems can be solved more accurately, economically and reliably.

3 Building information modelling (BIM)

A BIM model is a digital representation of physical and functional characteristics of a facility. As such, it serves as a shared knowledge resource for information about a facility forming a reliable basis for decision during its lifecycle from inception onward. If implemented, nearly every piece of information that an owner needs about a facility throughout its life can be made available electronically (Gralla and Lenz, 2017).

As Figure 3 illustrates, the BIM method is separated from conventional planning methods at the point from planning in three dimensions by using just geometric data to three dimensions combined with other information e.g. data like quality information or maximum loads. At this stage, it turns from a building model to a building information model, where for example also information about time and costs are associated with the fourth and fifth dimensions (BIMS-US, 2019).

Especially in the planning phase, problems often occur because a huge amount of data as in chapter II described is used to identify the right type of fastening system. The key competitive factor in selecting the most suitable building materials is to take the view of the planner out of the planning phase on the entire life cycle.

Focussing on the planning phase, challenges in the dimensioning process can be identified, such as the use of unstructured data or the influences of assuming physical

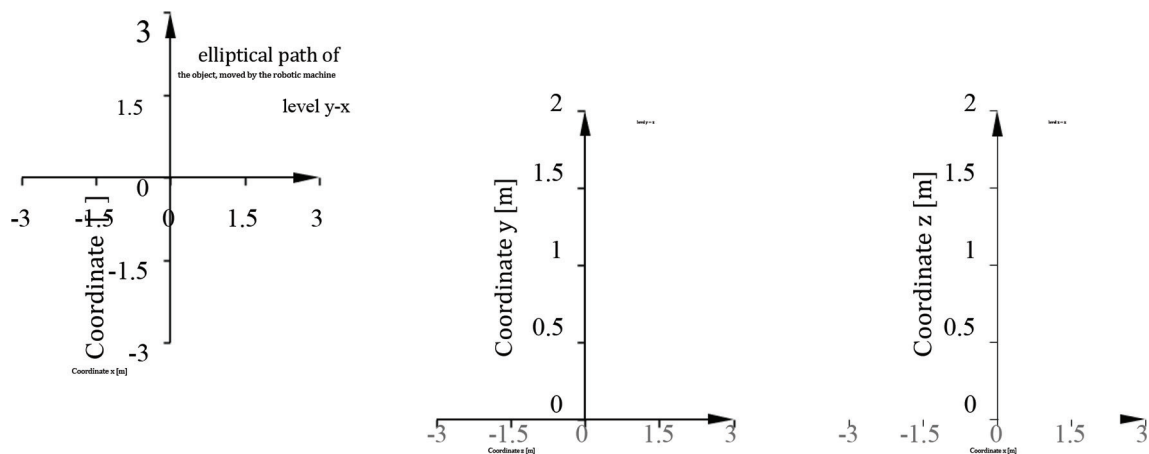

Fig. 2: Three-dimensional movement of the object and robotic machine (elliptical path).

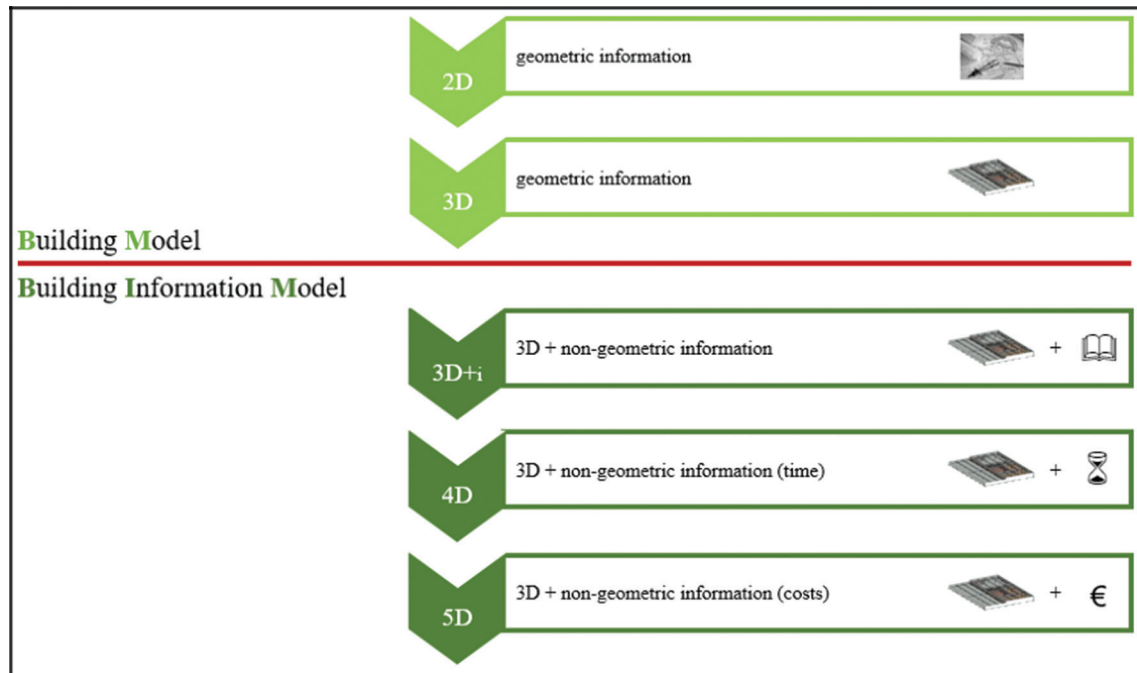

Fig. 3: Building information modelling vs. conventional planning.

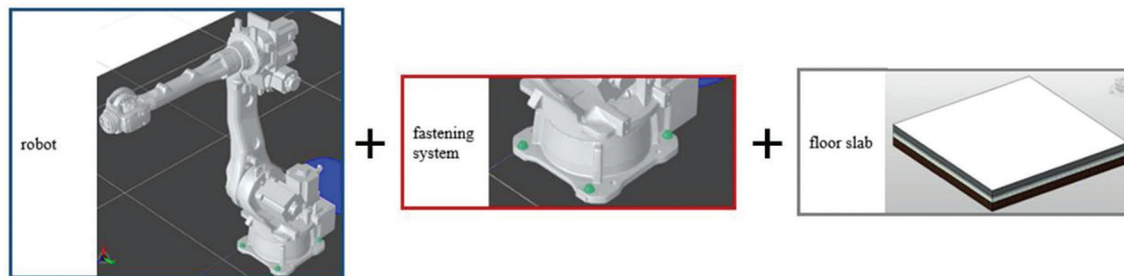

Fig. 4: Objects of investigation.

usage to define dynamic loads. In the building phase of a factory building, where production processes also run at the same time, the focus should be on installation times of the fastening system. For the operation phase exemplified by the fastening system, the main focus should be in particular on the long-term behaviour. Influences from the planning phase in which the fastening system is dimensioned have to be compared by real operating conditions of the dowels in order to identify the effective end of usability.

4 Data utilisation for life cycle design

In order to determine whether there are efforts by using data, it is necessary to examine the existing data base of

the several parts. This section describes a case study with one different motion sequences. Figure 4 illustrates the different parts to be investigated.

4.1 Data analysis of floor slab

For the present study, a floor slab was created within an BIM model. On this occasion, the floor slab is regarded as the main module, which consists of six submodules. The submodules are divided into coating system, concrete floor slab, sealing, cleanliness layer, base layer and underground (Table 1 and Figure 5). By viewing the individual components as submodules of a main module, it is possible to differentiate between various information and a higher number of influencing and relevant information.

Tab. 1: Data analysis of floor slab

Subsystem	Name building part	Building part ID	Parameter	Value	Unit
Concrete floor slab	Foundation area	Floor slab	Thickness	200	mm
Concrete floor slab	Foundation area	Floor slab	Concrete cover	35	mm
Concrete floor slab	Foundation area	Floor slab	Reinforcement	150	mm
Concrete floor slab	Foundation area	Floor slab	Reinforcement	10	mm
Concrete floor slab	Foundation area	Floor slab	Reinforcement	B500B	-
Concrete floor slab	Foundation area	Floor slab	Distributed load	500	kg/m ²
Concrete floor slab	Foundation area	Floor slab	Single load	750/21	kg/cm ²
Concrete floor slab	Foundation area	Floor slab	Surface treatment	smoothed	-
Concrete floor slab	Foundation area	Floor slab	Flatness	DIN 18202 table3/line 4	-

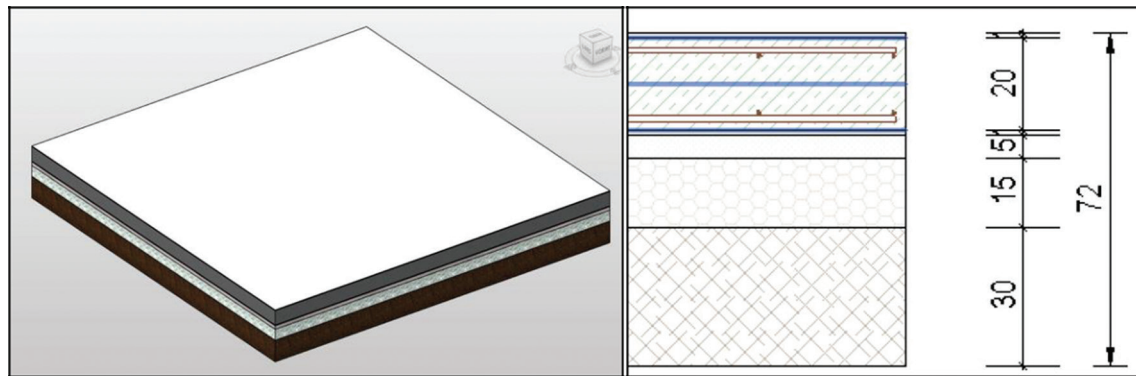

Fig. 5: Module of the floor plate.

Tab. 2: Data analysis of fastening system

Subsystem	Name building part	Building part ID	Parameter	Value	Unit
Fastening of machines	Transition area	Fastening system	Fastener diameter	16	mm
Fastening of machines	Transition area	Fastening system	Embedment depth	125	mm
Fastening of machines	Transition area	Fastening system	Edge distance for Concrete cone	190	mm
Fastening of machines	Transition area	Fastening system	Borehole diameter	18	mm
Fastening of machines	Transition area	Fastening system	Static-tension steel resistance	85.00	kN
Fastening of machines	Transition area	Fastening system	Static-shear steel resistance	55.00	kN
Fastening of machines	Transition area	Fastening system	Static-tension concrete Cone resistance	267.00	kN
Fastening of machines	Transition area	Fastening system	Static-shear resistance	Pry432.55	kN

Furthermore, it is possible to localise dependencies of the individual submodules.

For the investigation of the considered case study, only the submodule concrete floor slab is linked with non-geometric information, because this influences the assembly of a robot and the long-term bearing behaviour of fastening systems.

The non-geometric information is separated into four different categories as shown in Table 2. The created categories contain various information respectively data in order to guarantee a realistic investigation for the use case. The categories are subdivided into geometry, material, loads

and surface of the concrete floor slab. The information relevant for the use case is, for example, the thickness of the concrete floor slab and the concrete surface, which are specified in category 1. Concrete quality and reinforcement information are given in category 2. The different loads on the concrete floor slab are defined in category 3 as distributed loads and single loads. Category 4 contains information concerning flatness and surface quality. All this information of the different categories influences the assembling of a robot and the long-term behaviour of anchors over their entire life cycle, so that it must be taken into account.

4.2 Data analysis of the fastening system

The investigation of the fastening system in this case study is implemented with the application of a virtual bonding anchor. Mechanical properties of the fastening system in terms of geometry as well as resistance are selected on the basis of realistic, comparable products (see Table 2).

The structural fastening system consists of four fasteners with a horizontal spacing distance between the several fasteners of $s_1=400$ mm and $s_2=320$ mm and positioned in the field of the concrete slab (see Figure 6).

The action of the fastening system results from the kinematic movement of the fastened element, the robot. In this case study, the robot moves elliptically in three-dimensional space, i.e. a complete rotation around its own axis with vertical displacement of the robot arm (Seebauer, 2019). The motion and resulting action for 800 moments in time is shown in Figure 7 and is estimated for a number of 1,000,000 cycles for the service life of the robot. It can be seen that the complete movement results in two separate cycles with differentiated values of forces and moments. In the following, the two different cycles, the first part from 1 to 400 and the second part from 401 to 800, are to be considered and calculated individually.

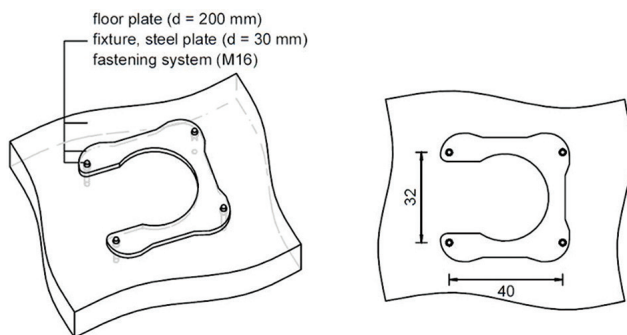

Fig. 6: Fastening system for the fixture of the robotic machine (dimensions in cm unless otherwise noted).

4.3 Data analysis of robot

In this case study we are investigating the influences of a robot machine from Yaskawa, type Motoman MH50 II. The data sets marked in Table 3 are relevant for the design of the fastening system from the analysis of the robot data. These are input parameters that influence the planning phase and are included in the design with the expected motion sequences and thus the utilisation status of the robot.

In this case study, a fundamental distinction can be drawn between the design with assumed motion sequences and structural concerns of the existing factory and the real operation phase. In the real operation phase, the real motion sequences for the works are running. For that purpose, the production machine, in this case the robot, has to be coded with the information of the production programme. Assuming that the data from the coding of the robot with the data in the BIM model could be connected especially with those of the fastening technology, it would be possible to use the fastening system on the basis of real-time data. By the integration of a warning function for the case that the fastener reaches the ultimate limit state of the load capacity, the fastening system could be taken to a higher degree of utilisation as a result. Another advantage would be that the fastening system only needs to be dimensioned once and the data could be retrieved for new applications, thus avoiding redundant work.

5 Investigation of data usage in a BIM model

The support of a BIM model in the design process of fastening systems offers the user, respectively the engineer, the advantage of an automated and real-time-based evaluation of the selection of fastening systems. Interactions

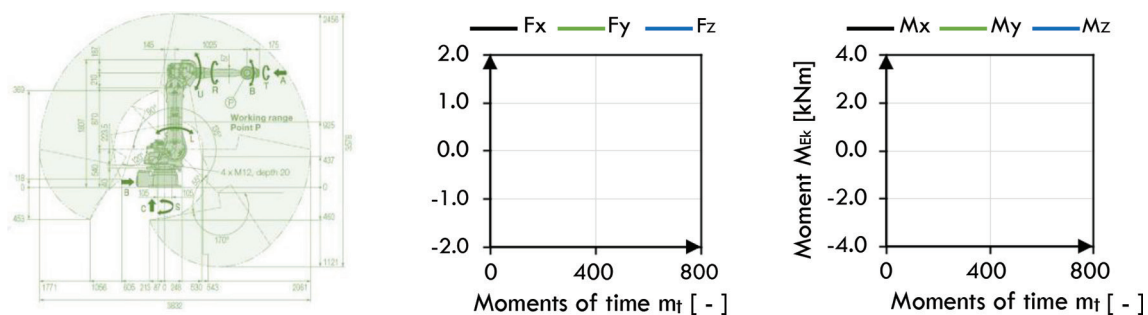

Fig. 7: Working range and axes of the robot (left) and resulting force (middle) and resulting moment (right) courses for the motion of the robotic machine.

Tab. 3: Data analysis robot Yaskawa Motoman MH50 II

Name scenario	Subsystem	Name building part	Building part ID	Parameter	Value
Production machine	Fastening of Machines	Foundation area	Fastening system	Anchor diameter	18 mm
Production machine	Fastening of machines	Foundation area	Fastening system	Anchor embedment depth	125 mm
Production machine	Floor space of the machines	Foundation area	Floor slab	Weight of the robot	550 kg
Production machine	Floor space of the machines	Foundation area	Floor slab	Maximum load capacity	50 kg
Production machine	Floor space of the machines	Foundation area	Floor slab	Maximum torque	216 Nm
Production machine	Floor space of the machines	Foundation area	Floor slab	Maximum moment of inertia	28 kg×m ²
Production machine	Floor space of the machines	Foundation area	Floor slab	Concrete quality	C30/37
Production machine	Floor space of the machines	Foundation area	Floor slab	Minimum width foundation	/
Production machine	Floor space of the machines	Foundation area	Floor slab	Minimum length Foundation	/
Production machine	Floor space of the machines	Foundation area	Floor slab	Minimum thickness foundation	160 mm
Production machine	Floor space of the machines	Foundation area	Floor slab	Minimum edge Distance dowel	210 mm
Production machine	Floor space of the machines	Foundation area	Floor slab	Concrete cover	35 mm
Production machine	Floor space of the machines	Foundation area	Floor slab	Reinforcement spacing longitudinal	150 mm
Production machine	Floor space of the machines	Foundation area	Floor slab	Reinforcement distance transverse	150 mm
Production machine	Floor space of the machines	Foundation area	Floor slab	Reinforcement diameter	10 mm
Production machine	Floor space of the machines	Foundation area	Floor slab	Reinforcement steel grade	B500B
Production machine	Floor space of the machines	Foundation area	Floor slab	Distributed load	5 kN/m ²
Production machine	Floor space of the machines	Foundation area	Floor slab	Single loads	7.5 kN/216 cm ²
Production machine	Floor space of the machines	Foundation area	Floor slab	Evenness	DIN 18202, table 3, line 4
Production machine	Floor space of the machines	Foundation area	Floor slab	Surface	Smoothed

of other processes as well as conditions and problematic boundary conditions can be routinely checked in advance and under consideration of geometric and semantic information. To use this further development in the design process, however, some important boundary conditions are required. On the one hand, structurally identical information must be provided in the form of electronic ETAs in order to enable routine processing of quantitative and semantic values. Furthermore, efficient and user-friendly program structures and software solutions must be developed to be able to process this information in fast computing processes.

The calculation and processing of information of the action and characteristic values of the fastening system in the current design models and concepts is based on simple empirical/physical equations, which require a certain level of engineering knowledge and define many branches for correspondingly limited and special design cases. A generally valid design under consideration of various possible boundary conditions is not feasible. The advanced design concept, used in this case study, for fastening systems under fatigue-relevant loading should have a general character and solve problems of time-independent and three-dimensional design.

5.1 Analysis of the motion sequence/ action and different design and solution concepts

For the analysis of different design situations/concepts, the force and moment information given in Figure 6 are used as the basis for the effect, the physical and mechanical motion sequence with the real actions.

One-dimensional loads, i.e. magnitude changes of a load in one specific constant direction, are currently dimensioned by conventional models. However, the transition to more complex problems of two- or three-dimensional loads with variable directions requires a comprehensive information of the load. In the first step, the method of the advanced design concept presented here uses the already known models of static design for differentiated failure possibilities for each time state. The resulting vectorial degrees of utilisation with consideration of the corresponding directions are used in a further step for the determination of multidimensional amplitudes, the change between two time states. The extreme value from the difference of the combination of all states is defined as the relevant maximum amplitude. Taking into account this maximum amplitude and the greatest amount of all utilisations, the models of the fatigue-relevant design can be adopted. The transformation of the basic static utilisation to fatigue-relevant

characteristic values is carried out with the models according to Wöhler curves (S/N diagram) and the Goodman diagram (Roylance, 2000), and they compared with the fatigue-relevant resistance in the final verification.

In comparison to these exact courses, approximations are also used and analysed in the form of sinusoidal functions. Here, the minimum and maximum points in the sinusoidal course are determined equivalent to the extreme values of the real action. A further variation in the investigation of the design concepts is the number of differentiated time moments. In this study, 30, 60, 90, 240 and 360 values are also used and examined. The influence of this design option is to be carried out and analysed with the comparison between the separate consideration of both cycles (as it is suggested in the exact concept) and the conventional approach, the duplication of the unfavourable course.

In the following, the results of the differentiated concepts 1 to 9 are given, where 1 is the exact system, described as the reference concept, in tabular form with the utilisation values for the steel failure and concrete failure (see Table 4).

As shown in Table 4, the concepts with the variation of the values of time moments exhibit no significant changes in the utilisation factors in this case study. Both the cases with doubling (3.1 and 3.2) or tripling (4.1 and

Tab. 4: Results of the different design concepts

Design concept	Specification	Period- part, cycle	Steel failure – highest utilisation	Concrete failure – higher utilisation
1.1	Reference concept, 120 moments of time, accurate utilisation concept, 2 load cycles	1	0.758 (100%)	0.471 (100%)
1.2		2	0.758 (100%)	0.497 (100%)
2.1	120 moments of time, accurate utilisation concept, 1 load cycle with double number of cycles	1	0.874 (115%)	0.472 (100%)
2.2		2	0.874 (115%)	0.498 (100%)
3.1	240 moments of time, accurate utilisation concept, 2 load cycles	1	0.758 (100%)	0.471 (100%)
3.2		2	0.758 (100%)	0.497 (100%)
4.1	360 moments of time, accurate utilisation concept, 2 load cycles	1	0.758 (100%)	0.471 (100%)
4.2		2	0.758 (100%)	0.497 (100%)
5.1	90 moments of time, accurate utilisation concept, 2 load cycles	1	0.758 (100%)	0.470 (100%)
5.2		2	0.758 (100%)	0.497 (100%)
6.1	60 moments of time, accurate utilisation concept, 2 load cycles	1	0.758 (100%)	0.469 (100%)
6.2		2	0.758 (100%)	0.497 (100%)
7.1	30 moments of time, accurate utilisation concept, 2 load cycles	1	0.757 (100%)	0.468 (99%)
7.2		2	0.758 (100%)	0.497 (100%)
8.1	120 moments of time, sine function with maximum and minimum, accurate utilisation concept, 2 load-cycles	1	0.764 (101%)	0.317 (87%)
8.2		2	0.709 (94%)	4.880 (983%)
9.1	Conventional design concept, sine function with max/min, 1 load cycle with double number of cycles	1	0.778 (103%)	0.114 (24%)
9.2		2	0.743 (98%)	0.114 (23%)

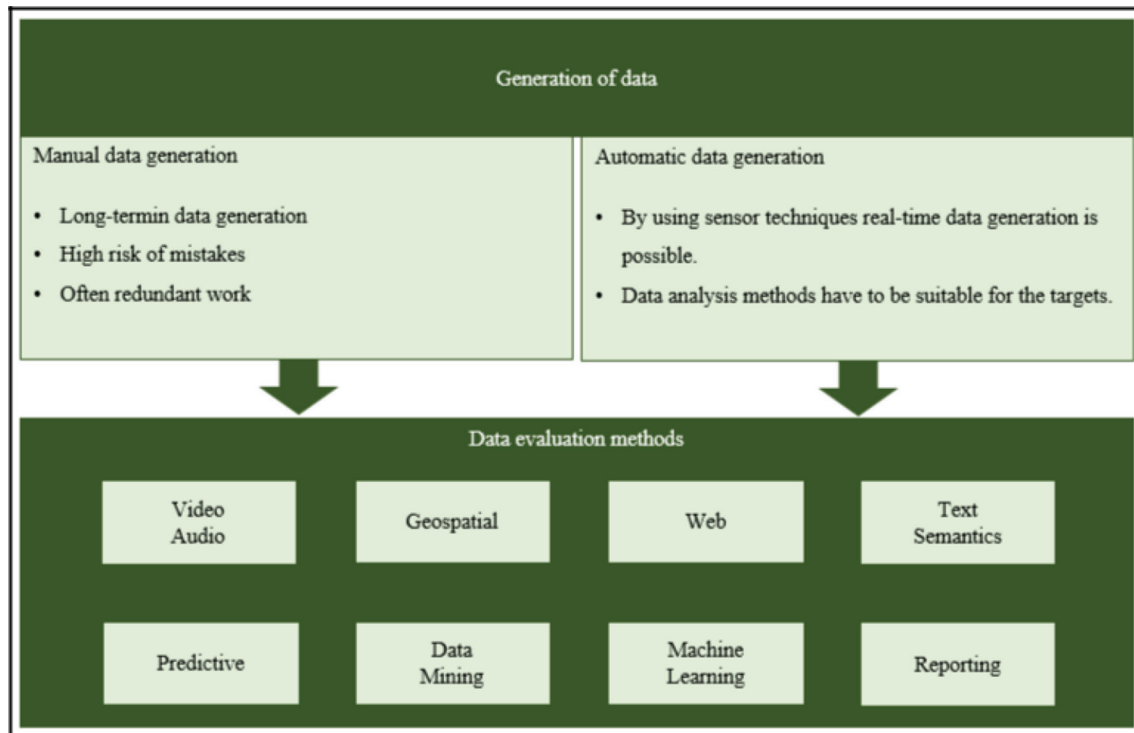

Fig. 8: Data generation and evaluation methods.

4.2) do not achieve a better economic efficiency, and the concepts 5.1 and 5.2 to 7.1 and 7.2 with reduction to 30 values show insignificant changes in the utilisation rates in terms of safety. Thus, a certain robustness can be pronounced for this case study of dimensioning with the advanced design concept.

The other concepts show significant differences. Thus, in the case of a conventional consideration of only one period part, which has a double number of cycles, the utilisation is more uneconomical and shows higher utilisation for steel failure. In the case of the approximations of the real loading course, using sinusoidal functions (8.1 and 8.2 with 9.1 and 9.2), different effects arise. The utilisation of steel failure and concrete failure are mixed and have both lower and higher values. Thus, on the one hand, a loss of economic efficiency and, on the other hand, safety-relevant uncertainties are taken into account (Figure 8).

6 Conclusion

The support in the design process of fastening systems offers the advantage of an automated and real-time based evaluation of the selection of fastening systems through a BIM model. Interactions and boundary conditions (conflicts) can also be automatically checked in

the same integrated environment. Furthermore, it is seen that structural information should be digitised from ETAs in advance, in order to enable processing of quantitative and qualitative values. Transferring this procedure to the multidisciplinary design practice (i.e. in a combined architecture, structural, and factory operational engineering disciplines), efficient and user-friendly program structures and software solutions must be developed to process this information in fast computing processes. This categorisation and integration of data is showcased herein. This conceptual process is further proposed, and a design example is also shown in order to verify the feasibility of the concept, with focus on life cycle-relevant design situations, with focus on the economically sensitive sector of automated manufacturing in factory environments.

An approach for automatic integration of various program sequences into a BIM model could be prospectively based on the solution for flexible robot programming. This solution enables a new form of robot programming, so that the functions and program sequences of the robot can be easily defined via a modular system, independent of manufacturers and without programming knowledge of the user. This concept offers the potential to harmonise the problem of differences in programming and could thus offer an efficient interface to a BIM model for the automated capturing of data from the production program.

Conveyed to an Industry 4.0 environment, the planning and facility management exercises, assisted by sensors and programmed warning features, can allow for a full integration of asset and production management.

References

- BIMS-US. (2019). Available et: <https://www.nationalbimstandard.org/about> on 24 February, 2019.
- Block, K., & Dreier, F. (2003). DAFStb-Heft 541: Das Ermüdungsverhalten von Dübelbefestigungen, Beuth Verlag, Berlin.
- CEN - Comité Européen de Normalisation. (2018). EN 1992 -4. Eurocode 2:2018, Design of concrete structures – Part 4: Design of fastenings for use in concrete. Belgium, CEN, Brussels.
- Cronin, B. (2015). *Industry Fears Over Fixings, New Civil Engineer (September 2015)*. EMAP Publishing Limited, London.
- fib - International Federation for Structural Concrete. (2011). *fib Bulletin 58 - Design of anchorages in concrete*. 2011, fib - International Federation for Structural Concrete, Lausanne, Switzerland
- Gralla, M., & Lenz, L. (2017). Digitalisierung im Baubetrieb – Building Information Modeling und virtuelle Zwillinge. In: Festschrift für Prof. Motzko, Darmstadt, Germany, 2017, p. 210.
- Grosser, P., Fuchs, W., & Eligehausen, R. (2011). A field study of adhesive anchor installations. *Concrete International*, 33.1, pp. 57-63.
- Kawahara, S., Doi, H., Shirato, M., Kajifusa, N., & Kutsukake, T. (2014). Investigation of the tunnel ceiling collapse in the Central Expressway in Japan. In: *Transportation Research Board 93rd Annual Meeting*, Washington DC, 12 January 2014 to 12 January 2014.
- Lenz, L., Gralla, M., Hoepfner, M., Spyridis, P., & Weist, K. C. (2019). BIM approach for automatic decision support: Case study fastening systems in factory adaptation planning, In: European Conference on Computing in Construction, Chania Crete, Greece, 2019.
- NTSB. (2007). *Highway Accident Report: Ceiling Collapse in the Interstate 90 Connector Tunnel at Boston, Massachusetts, July 10, 2006 (Highway Accident Report)*. National Transportation Safety Board, Washington.
- Roylance, D. (2000). *Mechanics of Materials – Lecture Notes, Fall 1999*. Massachusetts Institute of Technology: MIT OpenCourseWare.
- Scheller, E., & Künzlen, J. (2013). *Handbuch der Dübeltechnik*, Swiridoff Verlag, Künzelsau.
- Seebauer, D. (2019). *Roboterprogrammierung via Drag-and-Drop*. Productronic, Hüthig, Heidelberg, pp. 48-49.
- Weist, K. C. (2019). BIM im Bauprozessmanagement – Entwicklung einer Datenbasis für die modellbasierte Ablaufplanung und Kalkulation, Dortmund, Germany, p. 48.
- Wendner, R., Peitner, C., & Spyridis, P. (2013). Life-cycle robustness of fastening technology: A Christian Doppler Laboratory. Sonderheft: Werkstoffe und Konstruktionen - Innovative Ansätze/Beton- und Stahlbetonbau 108(2013), pp. 121-128.