

Protein family review

## The mitochondrial uncoupling proteins

Amalia Ledesma, Mario García de Lacoba and Eduardo Rial

Address: Centro de Investigaciones Biológicas, Consejo Superior de Investigaciones Científicas, Velázquez 144, 28006 Madrid, Spain.

Correspondence: Eduardo Rial. E-mail: [rial@cib.csic.es](mailto:rial@cib.csic.es)

Published: 29 November 2002

*Genome Biology* 2002, **3**(12):reviews3015.1–3015.9The electronic version of this article is the complete one and can be found online at <http://genomebiology.com/2002/3/12/reviews/3015>

© BioMed Central Ltd (Print ISSN 1465-6906; Online ISSN 1465-6914)

### Summary

The uncoupling proteins (UCPs) are transporters, present in the mitochondrial inner membrane, that mediate a regulated discharge of the proton gradient that is generated by the respiratory chain. This energy-dissipatory mechanism can serve functions such as thermogenesis, maintenance of the redox balance, or reduction in the production of reactive oxygen species. Some UCP homologs may not act as true uncouplers, however, and their activity has yet to be defined. The UCPs are integral membrane proteins, each with a molecular mass of 31–34 kDa and a tripartite structure in which a region of around 100 residues is repeated three times; each repeat codes for two transmembrane segments and a long hydrophilic loop. The functional carrier unit is a homodimer. So far, 45 genes encoding members of the UCP family have been described, and they can be grouped into six families. Most of the described genes are from mammals, but UCP genes have also been found in fish, birds and plants, and there is also functional evidence to suggest their presence in fungi and protozoa. UCPs are encoded in their mature form by nuclear genes and, unlike many nuclear-encoded mitochondrial proteins, they lack a cleavable mitochondrial import signal. The information for mitochondrial targeting resides in the first loop that protrudes into the mitochondrial matrix; the second matrix loop is essential for insertion of the protein into the inner mitochondrial membrane. UCPs are regulated at both the transcriptional level and by activation and inhibition in the mitochondrion.

### Gene organization and evolutionary history

#### Gene localization and structure

Mammals have five UCP homologs, of which UCP1–UCP3 are closely related, while UCP4 and BMCP1 are more divergent (see Figure 1). *Ucp1* genes have been assigned to mouse chromosome 8, rat chromosome 19 and human chromosome 4. The *Ucp2* and *Ucp3* genes are adjacent in each species. The human and mouse *Ucp2* genes are located 7–20 kilobases (kb) downstream of the *Ucp3* stop codon, an arrangement that has been interpreted as being the result of a duplication event; the *Ucp3-Ucp2* locus is located on mouse chromosome 7, human chromosome 11 (11q13, between the genetic markers D11S916 and D11S911), rat chromosome 1 and porcine chromosome 9. The brain UCP homolog *Bmcp1* is located on the X chromosome (Xq25–26) in humans,

between the markers DXS1206 and DXS1047. Human *Ucp4* has been mapped to 6p11.2–q12, close to the genetic marker SHGC-34952 [1].

The structure of the *Ucp1* gene is highly conserved in mouse, rat and human: six exons encompass the coding sequence, each exon encoding a transmembrane domain. The structures of *Ucp2* and *Ucp3* are similar to that of *Ucp1*, with six coding exons. *Ucp2* and *Ucp3* also have two or one additional non-translated 5' exons, giving eight and seven exons, respectively. A particular feature of the mouse and human *Ucp2* genes is the presence in exon 2 of several ATG-translation initiation codons in-frame with an open reading frame for an unknown peptide of 36 amino acids (the *Ucp2* coding sequence begins in exon 3). Unlike *Ucp1* and *Ucp2*, the

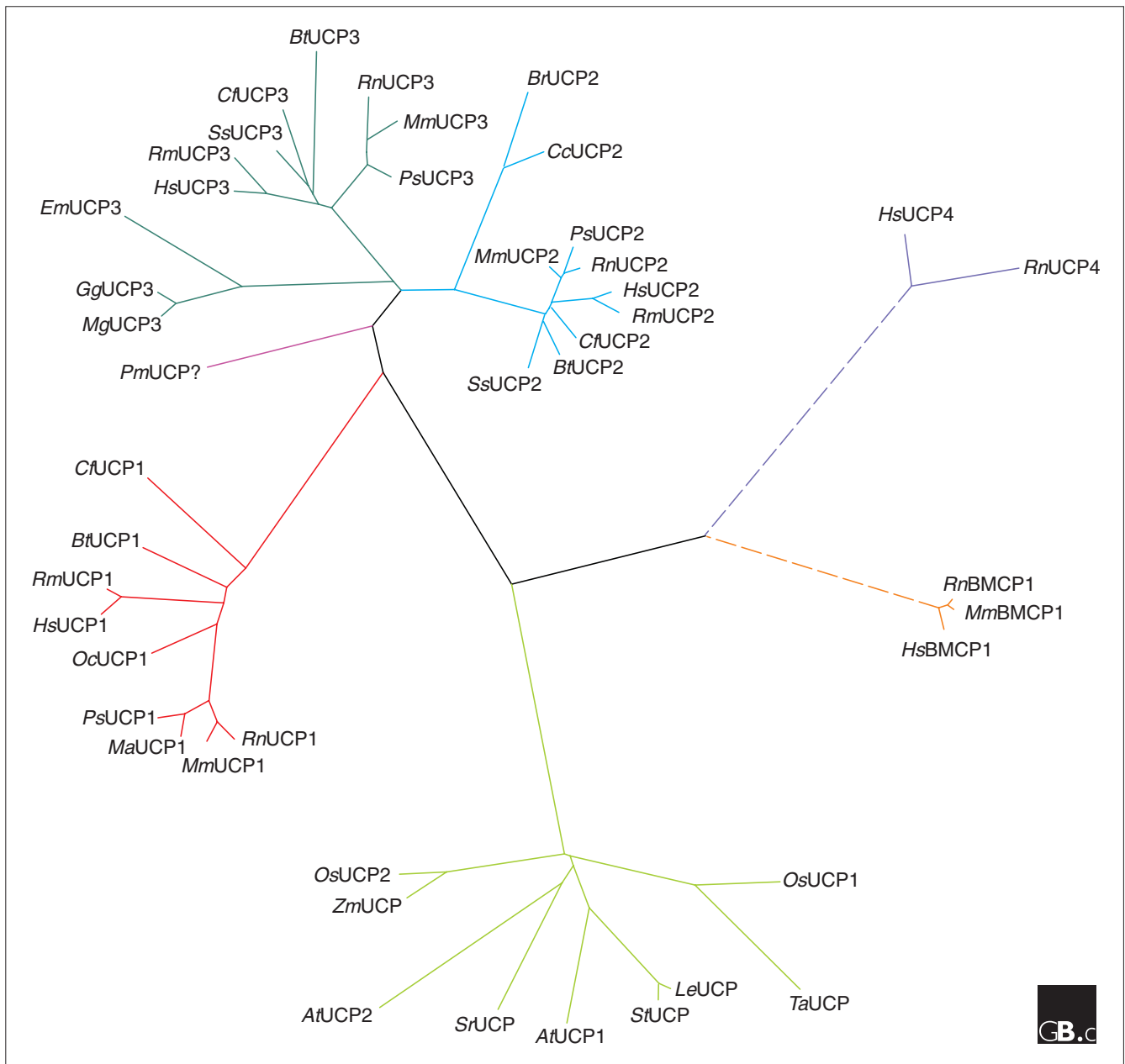

**Figure 1**  
 An unrooted phylogenetic tree depicting the evolutionary relationships among the members of the UCP family. Colors illustrate the six major classes into which the proteins cluster. The key to nomenclature can be found in Table I. Evolutionary distances were calculated from the sequence alignment applying the Jukes-Cantor correction method and the tree was constructed using the Neighbor-Joining method. The dotted lines indicate the more distant relationship of the UCP4 and BMCP1 proteins to the other UCPs.

human *Ucp3* gene is expressed as two splice variants generated by alternative splicing of the last intron; one transcript encodes the full-length protein (UCP3L), while the other encodes a truncated version (UCP3S) lacking the sixth transmembrane domain. This UCP3S variant is generated when a cleavage and polyadenylation signal (AATAAA), located in the last intron, terminates message elongation prematurely [2]. BMCP1 and UCP4 have also been reported to have

isoforms of varying lengths. The structure of the genes of plant UCPs is somewhat different; in *Arabidopsis*, for example, the UCP genes all contain nine exons [1]. *Arabidopsis AtUCP2* is located in chromosome 5.

**Evolutionary history**

The UCPs belong to the superfamily of metabolite carriers of the mitochondrial inner membrane [3]. Members of the

superfamily share both structural and functional similarities. Probably one of the most characteristic features is their tripartite structure, with three repeats of about 100 amino acids, each containing two hydrophobic stretches linked by a long hydrophilic loop (Figure 2). Sequence analysis has revealed two conserved sequence motifs at the two ends of each of the long loops. The first, P-x-[DE]-x<sub>2</sub>-[RK] in the single-letter amino-acid code (where x is any amino acid), is at the carboxy-terminal end of the first helix of each repeat, and the second, [ED]-G-x<sub>4</sub>-[aromatic]-[KR]-G, is at the carboxy-terminal end of the long matrix loop of each repeat. In fact, the sequence P-x-[DE]-x-[LIVAT]-[RK]-x-[LRH]-[LIVMFY]-[QGAIVM] (with PROSITE [4] accession number PS00215) has been used to recognize potential new members of the superfamily. It is striking that the most frequent structural arrangement in carriers and channels relies on the formation of  $\alpha$ -helical bundles with 12 membrane-spanning regions [5]. The members of the mitochondrial transporter superfamily are likely to have evolved from a primordial protein containing two transmembrane helices that was then triplicated. Since the functional carrier protein is a homodimer, it contains 12 transmembrane helices.

UCPs are present not only in animals and plants but also, according to functional evidence, in fungi and even protozoa [6]. This wide distribution is an indication that regulation of the efficiency of oxidative phosphorylation through physiological uncoupling may be a general strategy. Our phylogenetic analysis shows that the UCPs cluster into six distinct groups (Figure 1), and we have used this analysis to divide them in classes (Table 1). Only the UCP from the red sea bream does not fit into any of the major classes. It should be noted that names given in the literature to family members that are distantly related to UCP1-UCP3 could be misleading. Plant uncoupling proteins cluster together, and sequence comparison does not allow their functional assignation to any of the classes of animal UCPs. Two genes distantly related to *Ucp1-Ucp3* have been identified in the mammalian brain and

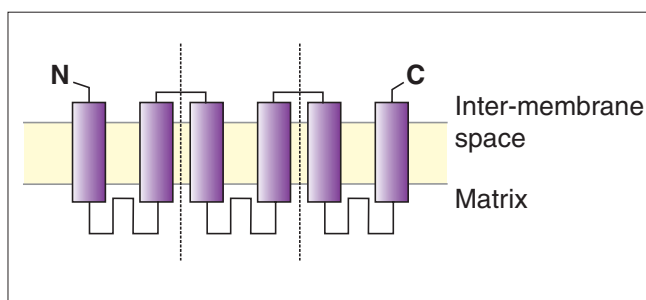

**Figure 2**  
The transmembrane arrangement of the UCPs. Six  $\alpha$ -helical regions span the lipid bilayer, with the amino and carboxyl termini oriented to the cytosolic side of the membrane and the long hydrophilic loops on the matrix side. Dotted lines separate the three portions of the tripartite structure.

named *Bmcp1* and *Ucp4*, but in fact two other members of the mitochondrial transporter superfamily, the oxoglutarate carrier and the dicarboxylate carrier, are more closely related to UCP1-UCP3 than these brain proteins [1].

### Characteristic structural features

The UCPs are integral membrane proteins that have molecular masses between 31 kDa and 34 kDa; the brain homologs (BMCP1 and UCP4) are larger proteins with masses of 36-38 kDa. They are all basic proteins with isoelectric points around 9. As noted earlier, they have a tripartite structure (Figure 3), with two hydrophobic regions in each repeat that most likely correspond to transmembrane  $\alpha$ -helices. The polypeptide chain crosses the lipid bilayer six times, and the amino and carboxyl termini protrude into the mitochondrial inter-membrane space (Figure 2) [7]. The two helices within each repeat are connected by a long hydrophilic loop and that is located on the matrix side of the protein. The functional unit is a dimer formed by two identical subunits. It has been demonstrated for other members of the carrier superfamily that the two monomers can be covalently linked in tandem to give a unit that is functionally competent [8]. No high-resolution structural data are yet available for any of the members of the metabolite transporter superfamily.

The UCPs do not have an amino-terminal cleavable import sequence to drive their incorporation into mitochondria. A recent report [9] has shown that, in UCP1, the net positive charge of the first matrix loop resembles a targeting signal and that it can interact with hTom20, a receptor protein of the outer mitochondrial membrane import complex. UCP1 has two other binding sites for hTom20, in the second transmembrane domain and in the central matrix loop, but the one in the second matrix loop is the critical one for targeting and insertion into the inner membrane [9].

Mitochondrial transporters such as the UCPs show the general properties described for carriers, including high substrate specificity and low turnover numbers. Under patch-clamp conditions, however, UCP1 displays a channel conductance of 75 pS, which is too high for a carrier mode. Deletion of nine amino acids from the third matrix loop of UCP1 leads to a pore-like state in which molecules of at least 1,000 Da can permeate, suggesting that this UCP1 mutant acts more like a channel than a carrier. This dual behaviour, carrier and channel, has also been observed for many other carriers and could be an indication that carriers and channels have a common origin and share a basic mechanism of transport. From a structural point of view, it suggests that there is a hydrophilic translocation pathway in the core of the protein, access to which would be controlled by gates, as are found in channels [10]. We have recently proposed that, in UCP1, the bundle formed by transmembrane  $\alpha$ -helices constitutes a hydrophilic channel, while the loops contribute to the formation of the gates [10].

**Table 1****Summary of the known members of the uncoupling protein family**

Class	Protein	Species	Common name	Accession number*
UCP1	BtUCP1	<i>Bos taurus</i>	Cow	P10861†
	CfUCP1	<i>Canis familiaris</i>	Dog	Q9GMZ1
	HsUCP1	<i>Homo sapiens</i>	Human	P25874
	RmUCP1	<i>Macaca mulatta</i>	Rhesus macaque	Q9N1E0†
	MaUCP1	<i>Mesocricetus auratus</i>	Syrian hamster	P04575
	MmUCP1	<i>Mus musculus</i>	Mouse	P12242
	OcUCP1	<i>Oryctolagus cuniculus</i>	Rabbit	P14271
	PsUCP1	<i>Phodopus sungorus</i>	Siberian hamster	Q9ER18
	RnUCP1	<i>Rattus norvegicus</i>	Rat	P04633
	UCP2	BtUCP2	<i>Bos taurus</i>	Cow
BrUCP2		<i>Brachydanio rerio</i>	Zebrafish	Q9W720
CfUCP2		<i>Canis familiaris</i>	Dog	Q9N2J1
CcUCP2		<i>Cyprinus carpio</i>	Common carp	Q9W725
HsUCP2		<i>Homo sapiens</i>	Human	P55851
RmUCP2		<i>Macaca mulatta</i>	Rhesus macaque	AF202130†‡
MmUCP2		<i>Mus musculus</i>	Mouse	P70406
PsUCP2		<i>Phodopus sungorus</i>	Siberian hamster	Q9ER17
RnUCP2		<i>Rattus norvegicus</i>	Rat	P56500
SsUCP2		<i>Sus scrofa</i>	Pig	O97562
UCP3	BtUCP3	<i>Bos taurus</i>	Cow	O77792
	CfUCP3	<i>Canis familiaris</i>	Dog	Q9N2I9
	EmUCP3	<i>Eupetomena macroura</i>	Hummingbird	Q98T90
	GgUCP3	<i>Gallus gallus</i>	Chicken	Q9DDT7
	HsUCP3	<i>Homo sapiens</i>	Human	P55916
	MmUCP3	<i>Macaca mulatta</i>	Rhesus macaque	Q9N1D8†
	MgUCP3	<i>Meleagris gallopavo</i>	Common turkey	Q90X50
	MmUCP3	<i>Mus musculus</i>	Mouse	P56501
	PsUCP3	<i>Phodopus sungorus</i>	Siberian hamster	Q9ER16†
	RnUCP3	<i>Rattus norvegicus</i>	Rat	P56499
UCP4	HsUCP4	<i>Homo sapiens</i>	Human	O95847
	RnUCP4	<i>Rattus norvegicus</i>	Rat	Q9EPH6
BMCP1	HsBMCP1	<i>Homo sapiens</i>	Human	O95258
	MmBMCP1	<i>Mus musculus</i>	Mouse	Q9Z2B2
	RnBMCP1	<i>Rattus norvegicus</i>	Rat	Q9JMH0
Plant UCP	AtUCP1	<i>Arabidopsis thaliana</i>	Mouse-ear cress	O65623
	AtUCP2	<i>Arabidopsis thaliana</i>	Mouse-ear cress	Q9ZWG1
	LeUCP	<i>Lycopersicon esculentum</i>	Tomato	AF472619‡
	OsUCP1	<i>Oryza sativa</i>	Rice	Q9AVG2

**Table 1 (continued)**

Class	Protein	Species	Common name	Accession number*
	OsUCP2	<i>Oryza sativa</i>	Rice	Q9AVG1
	StUCP	<i>Solanum tuberosum</i>	Potato	O24391
	SrUCP	<i>Symplocarpus renifolius</i>	Cabbage	Q9MBE7
	TaUCP	<i>Triticum aestivum</i>	Wheat	Q9FXQ5
	ZmUCP	<i>Zea mays</i>	Maize	AF461732‡
UCP?	PmUCP?	<i>Pagrus major</i>	Red sea bream	AF487341†‡

\*All accession numbers are for SWISS-PROT/TrEMBL [40], unless noted otherwise. †Only partial sequence is known; ‡sequence deposited in GenBank [41].

### Localization and function

The name of the UCP family derives from the function elucidated for the first known member of the family, UCP1, the uncoupling protein from brown adipose tissue. UCP1 was discovered some 25 years ago and was long considered to be the result of a unique adaptation of a mammalian tissue to non-shivering heat production. To understand the molecular basis of the thermogenic activity it is necessary to remember the fundamentals of mitochondrial bioenergetics (Figure 4) [11]. The term 'oxidative phosphorylation' embraces the biochemical processes that result in the mitochondrial production of ATP. In the respiratory chain, the transfer of electrons from substrates to oxygen is coupled to translocation of protons across the membrane. The energy stored in the proton gradient is used to drive the synthesis of ATP by an ATP synthase. At steady state, the number of protons that re-enter the matrix via the ATP synthase or other membrane components equal those pumped by the respiratory chain. Thus, for example, an increased cellular demand for ATP results in an increased rate of substrate oxidation by the respiratory chain. Thermogenesis in brown adipose tissue is achieved because UCP1 allows the re-entry of protons into the matrix and therefore uncouples respiration from ATP synthesis (Figure 4) [12].

Over the last few years, proteins homologous to UCP1 have been described not only in other mammalian tissues but also in other organisms, including plants. Four new uncoupling proteins have been described in mammals. UCP2 is expressed in many tissues. UCP3 is expressed only in brown adipose tissue and skeletal muscle, and UCP4 and BMCP1 are present only in brain. The function of the UCPs other than UCP1 is not yet clear, but their wide distribution suggests that regulation of the efficiency of oxidative phosphorylation through physiological uncoupling may be a general strategy. There is evidence to suggest, however, that some UCP homologs may not be involved in physiological uncoupling (discussed below).

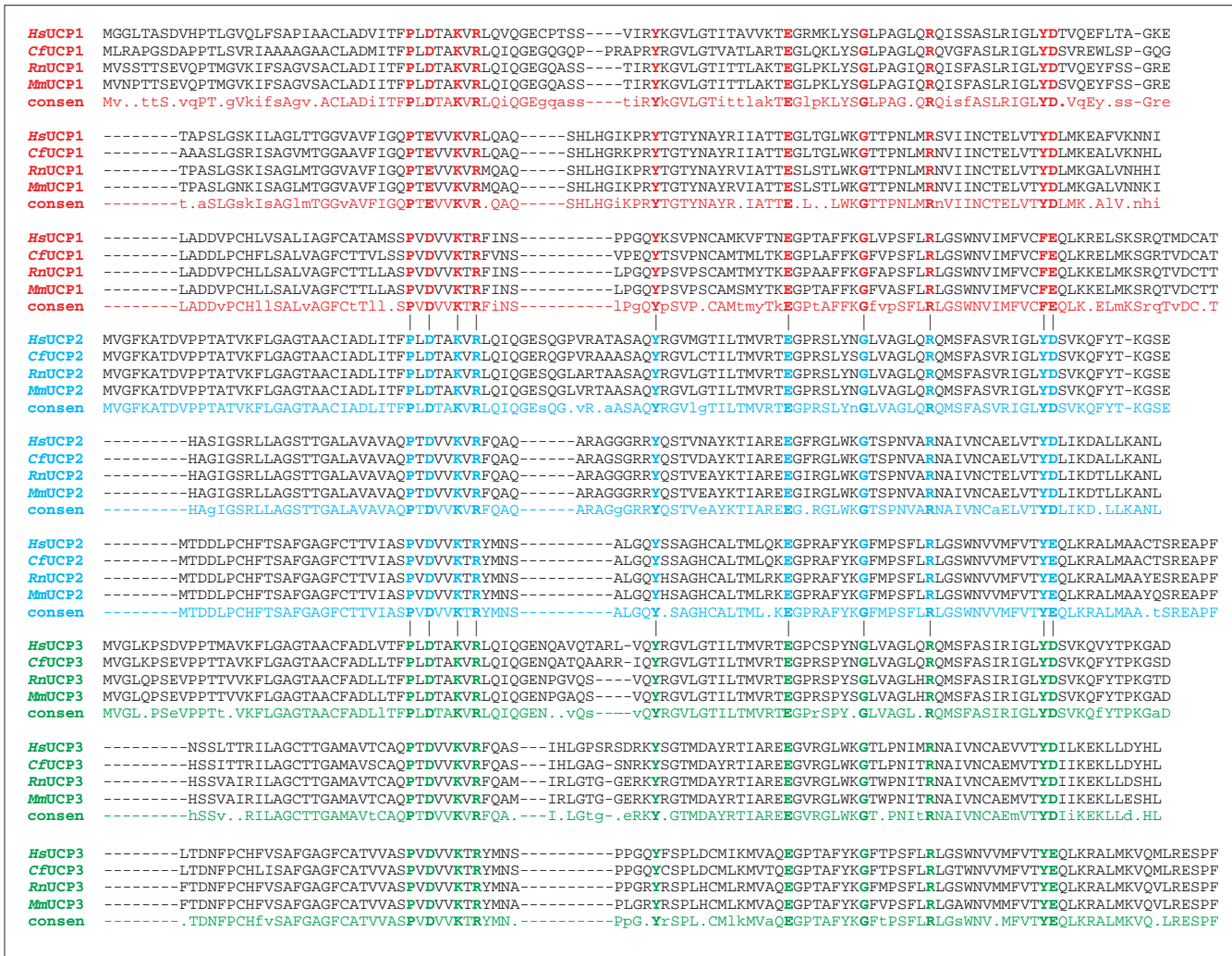

**Figure 3**

Sequence alignment of UCP1, UCP2 and UCP3 from human, dog, mouse and rat. Sequences are arranged to demonstrate the tripartite structure and lines between blocks help to identify amino acid residues strictly conserved in the three repeats. In the consensus sequence for each UCP homolog (consen), upper-case letters denote strict conservation while lower-case letters display the most frequent residue when there is variability.

UCPs are generally strongly regulated at two levels: transcription of the gene and protein activity in the mitochondrion. As an example of transcriptional regulation, the level of *Ucp1* mRNA rises in brown adipose tissue only 15 minutes after cold exposure. The 5' flanking region of the rat, mouse and human *Ucp1* genes contain *cis*-acting elements including a potent 200-bp enhancer involved in tissue-specific expression and hormonal regulation [13]. The enhancer is complex and contains response elements for cyclic AMP, retinoids, thyroid hormone, thiazolidinediones, and other regulators. The *Ucp2* promoter does not contain the TATA box typical of many promoters but instead is GC-rich; it contains several potential binding motifs for transcription factors such as Sp1, AP-1, AP-2, the cyclic AMP response element binding protein (CREB) and the muscle regulator MyoD [14]. Consensus binding motifs for the CCAAT box and the Y box have also

been described in the *Ucp2* promoter region. The *Ucp2* gene is downregulated *in cis* at the translational level by an upstream open reading frame located in exon 2 [15]. The expression of the *Ucp3* gene in skeletal muscle is also under strict transcriptional regulation, but the molecular mechanism controlling its expression has not been fully established [16]. In the proximal 5' flanking region of the *Ucp3* gene, several potential binding sequences for regulatory factors, such as MyoD, another muscle regulator MEF2, peroxisome-proliferator-activated receptors and thyroid hormone receptors have been described.

There are conflicting data on the regulation of the activity of the more recently described members of the UCP family within mitochondria, but the regulation of UCP1 is well established. Two ligands influence its activity: nucleotides

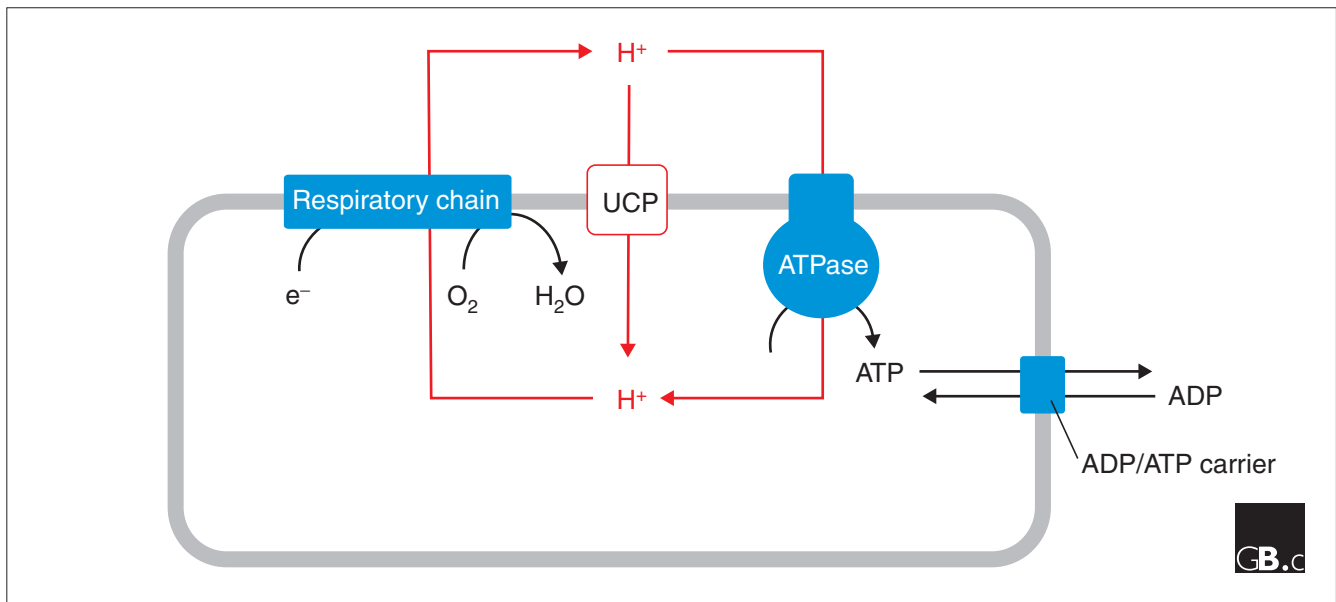

**Figure 4**

Energy dissipation mediated by the uncoupling proteins. During respiration, protons are pumped by the respiratory chain complexes and a proton electrochemical potential gradient is generated. The energy of the proton gradient drives the synthesis of ATP by the  $F_0F_1$ -ATPase. UCPs catalyze a regulated re-entry of the protons into the matrix. The ADP/ATP carrier exports the newly synthesized ATP to the cytosol in exchange for ADP.

and fatty acids. Furthermore, ubiquinone has recently been described as a cofactor essential for its activity [17]. Purine nucleotides bind to the protein from the cytosolic side of the membrane and inhibit conductance of protons. The ability of UCP1 to bind nucleotides has often been linked with its close relationship to the adenine nucleotide translocator (also called the ADP/ATP carrier, see Figure 5). Fatty acids override the inhibition of UCP1 by nucleotides and activate it. Fatty acids also act as second messengers of the hormone noradrenaline, since hormone-stimulated lipolysis generates fatty acids that act not only as substrates for respiration but also as activators of UCP1 [18]. The precise mechanism by which fatty acids regulate transport through UCP1 is a matter of debate, however. There are currently two hypotheses. The 'proton buffering model' proposes that the fatty acid acts as a prosthetic group for the UCP1 protein; the carboxylate moiety on the fatty acid would bind protons and deliver them to a site on UCP1 from which they are translocated to the other side of the membrane [19]. The alternative model, the 'fatty acid cycling hypothesis', proposes that UCP1 transports the fatty acid anion in one direction and that the protonated fatty acid then flips back across the lipid bilayer, resulting in a net transfer of one proton per fatty acid anion across the membrane [20].

The function, transport properties and regulation of other members of the UCP family are still being defined. It has been suggested that all the UCPs may respond to nucleotides and fatty acids in a similar way to UCP1 [21], but the physiological context in which UCP1 operates is unique (there is an

acute noradrenergic control of the thermogenic activity) and thus the physiological regulation of other UCPs is likely to be different.

The uncoupling proteins form part of a superfamily of metabolite transporters of the mitochondrial inner membrane, which are mainly anion carriers (Figure 5). Investigation of the bioenergetic properties of the mitochondria of brown adipose tissue was initiated when it was observed that their permeability to anions such as chloride or bromide was unusually high. It was subsequently shown that UCP1 can transport a variety of anions, an observation that has frequently led to the suggestion that UCP1 is a hydroxyl anion transporter rather than a proton carrier [22]. Its proposed activity as a fatty acid anion transporter would be in line with these observations [20].

UCP2 is the member of the family with the widest distribution among cell types [23], but its expression levels vary depending on the tissue and on the physiological situation. Since its discovery in 1997 [23], UCP2 has been shown to be involved in various cellular processes. The consensus is emerging that it probably has more than one function, which will depend on the physiological context. The phenotypes observed in *Ucp2*<sup>-/-</sup> knockout mice suggest that the wild-type UCP2 has an uncoupling activity *in vivo*: the animals are neither obese nor cold-sensitive but their macrophages produce more free radicals than wild-type macrophages, indicating a higher membrane potential [24]. The result of this high production of reactive oxygen species (ROS) is that

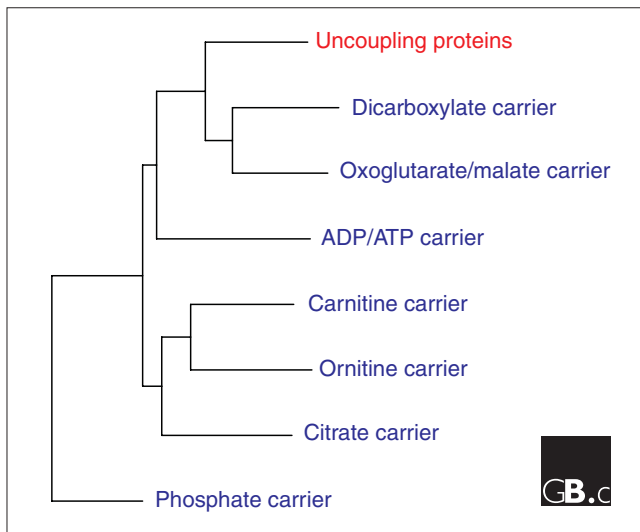

**Figure 5**  
A phylogenetic tree of representative members of the mitochondrial transporter superfamily, which includes UCPs.

the animals are more resistant to infection. Another research group has shown that *Ucp2*<sup>-/-</sup> knockout mice also have higher than wild type ATP levels in the pancreatic islets of Langerhans, resulting in abnormally high insulin levels [25]. Similarly, work with intact thymocytes from *Ucp2*<sup>-/-</sup> knockout mice has led to an estimate that UCP2 could be responsible for 50% of the resting proton leak [26]. UCP2 expression is generally increased in situations of oxidative stress, in which circumstance UCP2 would protect cells by limiting mitochondrial ROS production and therefore preventing the onset of apoptosis [27]. Macrophages respond to infection by lowering UCP2 levels and thus enhancing the production of ROS, which are used to fight infection. An interesting proposal has recently been put forward that UCP2 acts as a carrier for the superoxide anion, thus helping to decrease the mitochondrial concentration of ROS [28].

Several observations suggest that UCP2 could be involved in lipid metabolism. First, its expression is induced under starvation, when circulating fatty acid levels are elevated [29]. Moreover, when adipocytes are stimulated by the hormone leptin, the levels of UCP2 and of enzymes involved in fatty acid oxidation increase. Thus, when lipolysis is stimulated by leptin, fatty acids are not exported to liver but are oxidized in the adipocyte [30]. UCP2 could have a dual role in this process: it could trigger fat oxidation that is not coupled to energy-requiring processes, and/or it could prevent the oxidative damage usually produced under conditions of high lipid levels.

The expression of UCP3 is restricted to skeletal muscle and brown adipose tissue [31]. The physiological role and transport activity of UCP3 is still a matter of debate, despite the

large number of publications on the issue, but evidence suggests that it may not have a role in energy dissipation. In line with this idea, UCP3 levels increase during fasting, a situation where energy efficiency should be increased [29], and *Ucp3*<sup>-/-</sup> mice do not have altered whole-body metabolism [32], although at the cellular level they do show increased energetic efficiency [33]. The induction of UCP3 in muscle during starvation has been considered to be a consequence of its role in handling lipids as fuels, similar to the situation for UCP2 [34]. Two possible functions have been proposed. Although some authors argue that *Ucp3* is a carrier of fatty acids that facilitates their efflux from the mitochondrial matrix to help to regenerate free coenzyme A [35], while others suggest that UCP3 could prevent lipid-induced oxidative damage [36]. On the other hand, there are also indications that UCP3 has uncoupling activity. Firstly, transgenic mice overexpressing *Ucp3* have been shown to have a higher resting oxygen consumption than wild-type mice, and although their muscle fibres maintain a contractile performance similar to that of wild-type animals, energy turnover is clearly higher in the mutants [37]. Secondly, a recent paper has shown a correlation between the level of UCP3 expression, the rate of mitochondrial proton leakage and the success in weight loss of overweight women [38].

UCP4 and BMCP1 are distantly related UCP homologs that are expressed only in the brain. Their functions are not known, but they have been implicated in processes similar to those suggested for UCP2 and UCP3. The role of the plant uncoupling proteins is still being elucidated. Some of them (proteins from potato, *Arabidopsis* and cabbage) have been shown to respond when plants are subjected to cold stress, suggesting that they have a thermogenic role analogous to that of mammalian UCP1. These proteins have also been shown to reduce ROS generation, again showing a parallel with animal UCPs. Specific plant functions also involve UCP-mediated energy dissipation. During fruit ripening, heat is generated, and it had been previously thought that this thermogenesis was mainly due to the induction in the respiratory chain of the alternative oxidase. However, it has already been demonstrated in tomato and mango that UCPs play an essential role in this process [39].

## Frontiers

The uncoupling-protein field is growing rapidly, with an almost continuous description of new family members. The discovery of UCPs in many different eukaryotic organisms suggests that the regulation of energetic efficiency through the physiological uncoupling of oxidative phosphorylation may be a common strategy developed early in evolution. The current avalanche of data on the UCP family do not allow us to outline a definite task for each family member; the situation is more complex than anticipated. The view that is slowly emerging is that while the main function of UCP1 is thermoregulation, UCP2 is involved in the control

of ROS generation and UCP3 in the handling of lipids as fuels. Plant UCPs seem to have similar functions to the mammalian UCPs, but ascribing a role solely on the basis of sequence analysis would be premature. The example of UCP2 illustrates the need for a detailed investigation of each protein in its respective cellular context. The role of UCP2 in the physiology of macrophages, pancreatic  $\beta$  cells or white adipocytes is probably not the same. Clearly, defining the physiological regulation of the activity would help to clarify these issues.

Those studying the biochemistry of UCPs also have a lot of work ahead. There are still fundamental uncertainties about their transport mechanism, and thus they have been proposed to transport fatty acids, protons or superoxide ions. Are all UCPs 'true' uncoupling proteins, or are some of them metabolite carriers? How are these transporters organized so that they can readily switch from carrier mode to channel mode? No high-resolution structural data are yet available for any member of the mitochondrial carrier superfamily, and when this information becomes available it could prove a turning point in understanding the molecular basis of the transport mechanism, specificity and regulation of UCPs.

The scientific interest in this protein family can be easily understood. At the cellular level, their role in the control of ATP levels, redox balance, oxidative stress and apoptosis shows their importance. Disturbances in UCP function could underlie pathological states such as obesity, diabetes, inflammatory processes or cancer cachexia. Development of drugs that modulate the activity of the UCPs could one day become a new strategy for the treatment of these pathologies.

### Acknowledgements

We thank Frédéric Bouillaud and Daniel Ricquier for their helpful comments on the manuscript. This work has been supported by a grant from the Spanish Ministry of Science and Technology (BIO99-0870). A.L. is supported by a grant from the Comunidad de Madrid.

### References

- Ricquier D, Bouillaud F: **The uncoupling protein homologues: UCPI, UCP2, UCP3, StUCP and AtUCP.** *Biochem J* 2000, **345**:161-179.  
A comprehensive review of the UCPs.
- Solanes G, Vial-Puig A, Grujic D, Flier JS, Lowell BB: **The human uncoupling protein-3 gene.** *J Biol Chem* 1997, **272**:25433-25436.  
Description of the structure of the UCP3 gene.
- Walker JE, Runswick MJ: **The mitochondrial transport protein superfamily.** *J Bioenerg Biomembr* 1993, **25**:435-446.  
A review that includes a description of the characteristic features of the protein superfamily formed by the mitochondrial transporters of metabolites.
- PROSITE** [<http://ca.expasy.org/prosite/>]  
A database of protein families and domains
- Saier MH Jr: **Vectorial metabolism and the evolution of transport systems.** *J Bacteriol* 2000, **182**:5029-5035.  
A review that presents the hypothesis that all transport systems evolved from a common ancestor.
- Jarmuszkiewicz W, Sluse-Goffart CM, Hryniewiecka L, Sluse FE: **Identification and characterization of a protozoan uncoupling protein in *Acanthamoeba castellani*.** *J Biol Chem* 1999, **274**:23198-23202.  
The bioenergetic properties of mitochondria isolated from this amoeba suggest the presence of an uncoupling protein similar to the mammalian UCPs.
- Miroux B, Frossard V, Raimbault S, Ricquier D, Bouillaud F: **The topology of the brown adipose tissue mitochondrial uncoupling protein determined with antibodies against its antigenic sites revealed by a library of fusion proteins.** *EMBO J* 1993, **12**:3739-3745.  
Demonstration of the six transmembrane regions in UCPI.
- Trézéguet V, Le Saux A, David C, Gourdet C, Fiore C, Dianoux AC, Brandolin G, Lauquin G: **A covalent tandem dimer of the mitochondrial ADP/ATP carrier is functional in vivo.** *Biochim Biophys Acta* 2000, **1457**:81-93.  
Carriers operate as homodimers, and when the two monomers are expressed in tandem the carrier is fully functional.
- Schleiff E, McBride H: **The central matrix loop drives import of uncoupling protein 1 into mitochondria.** *J Cell Sci* 2000, **113**:2267-2272.  
Demonstration of the mechanism of targeting and insertion of UCPI into mitochondria.
- Arechaga I, Ledesma A, Rial E: **The mitochondrial uncoupling protein UCPI: a gated pore.** *IUBMB Life* 2001, **52**:165-173.  
A review on the transport properties of UCPI and the proposal of the existence in the core of UCPI of a translocation pore.
- Nicholls DG, Ferguson SJ: *Bioenergetics 3*. London: Academic Press; 2002.  
A standard and up-to-date textbook with a comprehensive introduction to membrane bioenergetics and the chemiosmotic theory.
- Nicholls DG, Locke RM: **Thermogenic mechanisms in brown fat.** *Physiol Rev* 1984, **64**:1-64.  
A classical review of the thermogenesis in brown adipose tissue and its regulation.
- Cassard-Doulcier AM, Gelly C, Fox N, Schrementi J, Raimbault S, Klaus S, Forest C, Bouillaud F, Ricquier D: **Tissue-specific and  $\beta$ -adrenergic regulation of the mitochondrial uncoupling protein gene: control by cis-acting elements in the 5'-flanking region.** *Mol Endocrinol* 1993, **7**:497-506.  
Comprehensive description of the structure of the UCPI gene.
- Yamada M, Hashida T, Shibusawa N, Iwasaki T, Murakami M, Monden T, Satoh T, Mori M: **Genomic organization and promoter function of the mouse uncoupling protein 2 (UCP2) gene.** *FEBS Lett* 1998, **432**:65-69.  
The structure of the UCP2 gene.
- Pecqueur C, Alves-Guerra MC, Gelly C, Levi-Meyrueis C, Couplan E, Collins S, Ricquier D, Bouillaud F, Miroux B: **Uncoupling protein 2, in vivo distribution, induction upon oxidative stress, and evidence for translational regulation.** *J Biol Chem* 2001, **276**:8705-8712.  
Translational regulation of UCP2 and tissue distribution.
- Acín A, Rodriguez M, Rique H, Canet E, Boutin JA, Galizzi JP: **Cloning and characterization of the 5' flanking region of the human uncoupling protein 3 (UCP3) gene.** *Biochem Biophys Res Commun* 1999, **258**:278-283.  
Characterization of the promoter region in UCP3.
- Echtay KS, Winkler E, Klingenberg M: **Coenzyme Q is an obligatory cofactor for uncoupling protein function.** *Nature* 2000, **408**:609-613.  
A description of the role of ubiquinone as a cofactor for the UCPI.
- Rial E, González-Barroso MM: **Physiological regulation of the transport activity in the uncoupling proteins UCPI and UCP2.** *Biochim Biophys Acta* 2001, **1504**:70-81.  
A review on the regulation of UCPI, with a historical perspective.
- Klingenberg M, Echtay KS: **Uncoupling proteins: issues from a biochemist point of view.** *Biochim Biophys Acta* 2001, **1504**:128-143.  
A review on the mechanism of transport and regulation of mammalian UCPs.
- Garlid KD, Jaburek M, Jezek P: **Mechanism of uncoupling protein action.** *Biochem Soc Trans* 2001, **29**:803-806.  
A review summarizing the transport mechanism of UCPI as a fatty acid anion carrier.
- Jezek P: **Possible physiological roles of mitochondrial uncoupling proteins-UCPn.** *Int J Biochem Cell Biol* 2002, **34**:1190-1206.  
A review on the hypotheses for the role of the mammalian uncoupling proteins.



22. Nicholls DG: **Brown adipose tissue mitochondria.** *Biochim Biophys Acta* 1979, **549**:1-29.  
A review on the bioenergetic properties of brown fat mitochondria and the uncoupling protein UCP1.
23. Fleury C, Neverova M, Collins S, Raimbault S, Champigny O, Levi-Meyrueis C, Bouillaud F, Seldin MF, Surwit RS, Ricquier D, Warden CH: **Uncoupling protein-2: a novel gene linked to obesity and hyperinsulinemia.** *Nat Genet* 1997, **15**:269-272.  
First description of the existence of UCP2.
24. Arsenijevic D, Onuma H, Pecqueur C, Raimbault S, Manning BS, Miroux B, Couplan E, Alves-Guerra MC, Goubern M, Surwit R, et al.: **Disruption of the uncoupling protein-2 gene in mice reveals a role in immunity and reactive oxygen species production.** *Nat Genet* 2000, **26**:435-439.  
UCP2<sup>-/-</sup> knockout mice are more resistant to infection and have higher ROS production.
25. Zhang CY, Baffy G, Perret P, Krauss S, Peroni O, Grujic D, Hagen T, Vidal Puig J, Boss O, Kim YB, et al.: **Uncoupling protein-2 negatively regulates insulin secretion and is a major link between obesity, beta cell dysfunction, and type 2 diabetes.** *Cell* 2001, **105**:745-755.  
UCP2<sup>-/-</sup> knockout mice present higher ATP levels in the pancreatic islets and increased insulin secretion.
26. Krauss S, Zhang CY, Lowell BB: **A significant portion of mitochondrial proton leak in intact thymocytes depends on expression of UCP2.** *Proc Natl Acad Sci USA* 2002, **99**:118-122.  
Comparison of the bioenergetic properties of thymocytes with and without UCP2 is consistent with an uncoupling activity of the protein.
27. Diehl AM, Hoek JB: **Mitochondrial uncoupling: role of uncoupling protein anion carriers and relationships to thermogenesis and weight control "The benefits of losing control".** *J Bioenerg Biomembr* 1999, **31**:493-506.  
A review on the physiological function of UCP1, UCP2 and UCP3.
28. Echtay KS, Roussel D, St-Pierre J, Jakabsons MB, Cadenas S, Stuart JA, Harper JA, Roebuck SJ, Morrison A, Pickering S, Clapham JC, Brand MD: **Superoxide activates mitochondrial uncoupling proteins.** *Nature* 2002, **415**:96-99.  
A report showing that UCP2 acts as a superoxide ion carrier.
29. Samec S, Seydoux J, Dulloo AG: **Role of UCP homologues in skeletal muscles and brown adipose tissue: mediators of thermogenesis or regulators of lipids as fuel substrate.** *FASEB J* 1998, **12**:715-724.  
Paradoxical observation that starvation leads to an increase in the levels of UCP2 and UCP3.
30. Wang MY, Lee Y, Unger RH: **Novel form of lipolysis induced by leptin.** *J Biol Chem* 1999, **274**:17541-17544.  
Leptin induces lipolysis in white adipose tissue but fatty acids are oxidized in the adipocyte rather than being exported.
31. Boss O, Samec A, Paoloni-Giacobino A, Rossier C, Dulloo A, Seydoux J, Muzzin P, Giacobino JP: **Uncoupling protein-3: A new member of the mitochondrial carrier family with tissue-specific expression.** *FEBS Lett* 1997, **408**:39-42.  
First description of the existence of UCP3.
32. Gong DW, Monemdjou S, Gavrilova O, Leon LR, Marcus-Samuels B, Chou CJ, Everett C, Kozak LP, Li C, Deng C, et al.: **Lack of obesity and normal response to fasting and thyroid hormone in mice lacking uncoupling protein-3.** *J Biol Chem* 2000, **275**:16251-16257.  
UCP3-knockout mice do not evidence changes in whole body metabolism.
33. Cline GW, Vidal Puig AJ, Dufour S, Cadman KS, Lowell BB, Shulman GI: **In vivo effects of uncoupling protein-3 gene disruption on mitochondrial energy metabolism.** *J Biol Chem* 2001, **276**:20240-20244.  
Demonstration that muscle mitochondria from UCP3-knockout mice present a higher energetic efficiency and therefore that *in vivo* UCP3 has an uncoupling activity.
34. Weigle DS, Selfridge LE, Schwartz MW, Seeley RJ, Cummings DE, Havel PJ, Kuijper JL, Beltran del Rio H: **Elevated fatty acids induce uncoupling protein 3 expression in muscle: a potential explanation for the effect of fasting.** *Diabetes* 1998, **47**:298-302.  
UCP3 expression is linked to the use of fatty acids as fuel rather than to the need to dissipate energy.
35. Himms-Hagen J, Harper ME: **Physiological role of UCP3 may be export of fatty acids from mitochondria when fatty acid oxidation predominates: an hypothesis.** *Exp Biol Med* 2001, **226**:78-84.  
A review on the physiological function of UCP3, presenting the hypothesis that its role is the export of fatty acids from the mitochondrial matrix.
36. Boss O, Hagen T, Lowell BB: **Uncoupling proteins 2 and 3: Potential regulators of mitochondrial energy metabolism.** *Diabetes* 2000, **49**:143-156.  
A review on the physiological function of UCP2 and UCP3.
37. Curtin NA, Clapham JC, Barclay CJ: **Excess recovery heat production by isolated muscles from mice overexpressing uncoupling protein-3.** *J Physiol* 2002, **542**:231-235.  
Demonstration that muscle cells from transgenic mice overexpressing UCP3 have a lower energetic efficiency.
38. Harper ME, Dent R, Monemdjou S, Bézaire V, Van Wyck L, Wells G, Kavaslar GN, Gauthier A, Tesson F, McPherson R: **Decreased mitochondrial proton leak and reduced expression of uncoupling protein 3 in skeletal muscle of obese diet-resistant women.** *Diabetes* 2002, **51**:2459-2466.  
A report indicating an energy dissipatory role of UCP3 in humans.
39. Considine MJ, Daley DO, Whelan J: **The expression of alternative oxidase and uncoupling protein during fruit ripening in mango.** *Plant Physiol* 2001, **126**:1619-1629.  
UCP in mango plays an important role in the process of fruit ripening.
40. **SWISS-PROT/TrEMBL** [<http://ca.expasy.org/sprot/>]  
SWISS-PROT is a curated protein sequence database and TrEMBL is a computer-annotated supplement of SWISS-PROT.
41. **GenBank** [<http://www.ncbi.nlm.nih.gov/Genbank/>]  
Database of protein and DNA sequences.