

**DESIGN FOR SUSTAINABILITY:
ADDRESSING FOOD WASTE BEHAVIOUR**

Machiko Niimi

A thesis submitted for the degree of Master of Design
At the University of Otago, New Zealand

6 December 2012

ABSTRACT

This research explores current approaches and frameworks to enable design to contribute to sustainable behaviour. In particular, this research closely examined Shove's Comfort, Cleanliness and Convenience (3Cs) for its applicability in the design process, with a view to generating design interventions. In mid- to high-income countries, consumer behaviour is recognised as the major issue contributing to food waste. Sustainability approaches were applied to the context of food waste, in order to see how they could inform designing for this problem.

First, a pilot observation was carried out to investigate whether Shove's 3Cs approach could be applied to the food waste context. The results of the pilot observation suggested that the 3Cs could be a useful tool for uncovering everyday norms and habits governing food waste. A major observation was then carried out at a farmers' market, using human centred design methods. The analysis of the observations led to frame a design brief: To improve the food waste stream at the farmers' market through design interventions relating to take-away coffee practices. The design ideation and refinement process resulted in three design concepts, which sought to enable more sustainable behaviour by; a) removing barriers to sustainable behaviour with the 3Cs; b) emotionally durable re-use cups; and c) supporting the demand for the 3Cs.

The evaluation of the design process identified that the 3Cs, used in conjunction with a social practice approach, revealed rich nuances in everyday practices with respect to food waste. These approaches were, therefore, found to be complementary to human centred design processes in framing the design problem and to forming the design brief. They were also found to be particularly useful in making sense of wicked problems. However, they were limited in their application during the design ideation phase, which reinforced the importance of conventional design ideation tools, such as sketching and prototyping. This thesis concludes that Shove's 3Cs and social practice approach are useful tools when framing design problems. In addition, this research reinforced the importance of utilising various strategies, as required, when designing for sustainable behaviour. Further research in effective application of the sustainability approaches with reference to how they inform the design process would enrich the research in the area of design for sustainable behaviour.

ACKNOWLEDGEMENTS

I would like to thank John Moore and Catherine Irvine for their support and assistance during the farmers' market observation. Their enthusiasm to minimise waste was always inspiring and I am grateful to have had the opportunity to research farmers' market as the context of this thesis.

Thank you to my supervisors, Dr Mick Abbott, Associate Professor Sarah Wakes and Dr Mark McGuire. I am appreciative of Dr Mick Abbott's encouragement in undertaking research in this area. I am also indebted to Associate Professor Sarah Wakes and Dr Mark McGuire for their generous feedback and the regular meetings to navigated me to the finish line.

I would also like to acknowledge my colleagues and students at the Otago Polytechnic School of Design. In particular, I would like to thank the first year product design students of 2011 and 2012 for enthusiastically taking part in the waste audit. Thank you also to the School of Design colleagues and students for their support and being a constant source of inspiration. Special thank you to Caro McCaw and Dr Margo Barton for their support, and company during many weekend and after-hour study shifts.

A heartfelt thanks to Dr D Wood who generously took time to edit and comment on my thesis and to Katy Miller for sharing her expertise with formatting. Thank you also to Andrew Wallace for his assistance during the design ideation phase.

Finally, countless thanks to my husband, Kurt McEwen, for his unconditional support and to my family Masakazu, Kyoko and Jun Niimi for their unwavering encouragement and optimism.

LIST OF ABBREVIATIONS

Shove's 3Cs ¹	Shove's Comfort, Cleanliness and Convenience
The 3Cs ²	The Comfort, Cleanliness and Convenience
LCA	Life Cycle Analysis
C2C.....	Cradle to Cradle

1 & 2 This research will discuss Shove's 3Cs also as the 3Cs and as a singular framework. For example, "Shove's 3Cs is assessed for its applicability to the design process."

TABLE OF CONTENTS

Abstract.....	iii
Acknowledgements.....	v
List of Abbreviations.....	vi
Table of Contents.....	vii
Table of Figures	xi

CHAPTER ONE: INTRODUCTION

1.1 Research Problem.....	4
1.2 Contextual Background.....	5
1.3 Research Aims and Objectives	6
1.4 Structure of this Study	7
1.5 Definition	8

CHAPTER TWO: LITERATURE REVIEW

2.1 Sustainability Design Frameworks	11
2.2 Relationship Between Attitude and Behaviour	14
2.3 Product-Led Interventions	19
2.4 Causes for Normality	27
2.5 Social Practice Theory and Sustainability.....	31
2.6 Comfort, Cleanliness and Convenience (3Cs).....	35
2.7 Summary	43

CHAPTER THREE: RESEARCH DESIGN

3.1 Design-Led Research.....	47
3.2 Design Thinking	47
3.3 Interdisciplinary Approach	48
3.4 Reflective Practice.....	48

CHAPTER FOUR: PILOT OBSERVATION

4.1	Sites of Pilot Observation	53
4.2	Methodology	53
4.3	Results and Discussion.....	54
4.4	Summary	62

CHAPTER FIVE: MAJOR OBSERVATION

5.1	Site of Observation and Design Intervention	67
5.2	Methodology	71
5.3	Results and Discussion	73
5.4	Summary and Design Brief.....	87

CHAPTER SIX: DESIGN IDEATION AND EVALUATION

6.1	Methodology	93
6.2	Rationale for the Design Brief	93
6.3	Suite of Design Concepts	96
6.4	Design Concept One: Disposable Coffee Cup Re-design	100
6.5	Design Concept Two: Re-design Re-use Cup.....	106
6.6	Design Concept Three: Re-use Cup Washer.....	113
6.7	Summary	119

CHAPTER SEVEN: DISCUSSION

7.1	Approaches and Frameworks to Enable Sustainable Behaviour	123
7.2	Shove's 3Cs and an Extended Sustainability Context	124
7.3	Shove's 3Cs, Social Practice and the Design Process	126
7.4	Pluralistic Approach	129
7.5	Limitations	133

CHAPTER EIGHT: CONCLUSION

8.1 Conclusions 137
8.2 Recommendation for Future Research 138

REFERENCES

References 141
Image References 146

APPENDICES

Appendix One: Ideation Process Work..... 149
Appendix Two: Ethical Approval Forms 161

TABLE OF FIGURES

<i>Figure 2.1</i>	<i>Elements of Practice</i>	32
<i>Figure 2.2</i>	<i>Nordic Walking Innovation</i>	33
<i>Figure 2.3</i>	<i>Transitions in the Bathroom</i>	34
<i>Figure 2.4</i>	<i>Shove’s Comfort Cleanliness and Convenience</i>	41
<i>Figure 3.1</i>	<i>Outline of Research Process</i>	49
<i>Figure 4.1</i>	<i>Single Serve Disposable Packaging</i>	55
<i>Figure 4.2</i>	<i>Bokashi Composting Process</i>	57
<i>Figure 4.3</i>	<i>Pig Bin at Use During Food Preparation</i>	59
<i>Figure 4.4</i>	<i>A Site for Returning Plates and Disposing of Uneaten Food</i>	60
<i>Figure 5.1</i>	<i>Stakeholders of the Farmers’ Market Waste Minimisation Initiative</i>	68
<i>Figure 5.2</i>	<i>Timeline</i>	69
<i>Table 5.3</i>	<i>Waste Categorisation</i>	70
<i>Figure 5.4</i>	<i>Waste Audit Process</i>	74
<i>Figure 5.5</i>	<i>Packaging Audit Process</i>	79
<i>Figure 5.6</i>	<i>Samples of Waste Separation</i>	81
<i>Table 5.7</i>	<i>Analysis of Waste Separation</i>	82
<i>Figure 5.8</i>	<i>Changes Made to Waste Separation Signage</i>	83
<i>Figure 5.9</i>	<i>Observation Analysis and Insights</i>	88
<i>Figure 6.1</i>	<i>Elements of Take-Away Coffee Practice</i>	95
<i>Figure 6.2</i>	<i>Ideation Sketches 1</i>	97
<i>Figure 6.3</i>	<i>Ideation Sketches 2</i>	98
<i>Figure 6.4</i>	<i>Ideation Sketches 3</i>	99
<i>Figure 6.5</i>	<i>Disposable Cup Re-design</i>	102

<i>Figure 6.6 Re-use Cup Re-design</i>	<i>108</i>
<i>Figure 6.7 Keep Cup.....</i>	<i>112</i>
<i>Figure 6.8 Re-use Cup Washer</i>	<i>115</i>
<i>Figure 6.9 Elements Governing Cleanliness.....</i>	<i>118</i>
<i>Figure 6.10 Concept 1: Disposable Re-design</i>	<i>119</i>
<i>Figure 6.11 Concept 2: Reuse cup Re-design</i>	<i>119</i>
<i>Figure 6.12 Concept 3: Re-use cup washer.....</i>	<i>119</i>
<i>Figure 7.1. Analysis of Applicability of Shove’s 3Cs to the Design Process</i>	<i>127</i>
<i>Figure 7.2 Analysis of Application of Design for Sustainability Approaches to the Design Process</i>	<i>130</i>
<i>Figure 7.3 Example of Analogy During Ideation.....</i>	<i>132</i>

CHAPTER ONE: INTRODUCTION

1.0 INTRODUCTION

Social and environmental issues are directly related to the practice of designers (Papanek, 1971). Designers' considerations during development of products and services lead to significant environmental, social and financial impacts, which underpin recent sustainability issues (Shedroff, 2009; Thorpe, 2010). The way in which a product and service is used is another area of consideration with respect to sustainability. Life cycle analyses of products commonly indicate the use phase of products as one of the major contributors to negative environmental impacts (Jelsma & Knot, 2002). For instance, the way in which a user washes clothes with respect to issues including frequency of wash, the washing machine, temperature of water, choice and amount of detergent and methods of drying, contribute to environmental impacts. As a result, there has been increasing interest for industrial designers to explore ways of designing products that encourage users to be more sustainable. (Lilley, Bhamra & Lofthouse, 2006; Lockton, Harrison, & Stanton, 2008; McKenzie-Mohr, D., 2000; Howard, 2004).

The study of user behaviour is therefore a key area of research necessary for design for more sustainable practices. The ways users interact with products and how their behaviour leads to environmental impact is a significant area of interdisciplinary research. A classic approach to changing user behaviour is to increase awareness about sustainability issues. However, recent studies highlight the inconsistency between attitude and behaviour. Despite knowledge and pro-sustainability attitudes, behaviours in our daily lives often do not reflect our intentions (McKenzie-Mohr, D., 2000; Fletcher, 2007). Even consumers with a positive attitude towards re-usable cloth bags for shopping can find themselves at a supermarket without having brought a cloth bag. Similarly, long showers or driving a distance that can be travelled on foot are part of reality for many, even for those with an interest in sustainability issues and intentions to save energy resources.

Therefore, this research will investigate the strategies for bridging the gap between our attitudes and behaviours relevant to design for sustainability. In addition, this research explores effective interventions for situations where users may not have a current awareness of sustainability issues.

More recent studies in sociology shift the focus from individual behaviour to social norms to identify habits and norms that are embedded in everyday lives (Shove, 2010; Evans 2012). For instance, resource consuming norms, such as daily showering, are as much an individual choice as a part of a social norm (Shove 2003). Uncovering how new norms are adopted may illustrate ways to introduce more sustainable norms. In contrast, some studies examine ways to utilise technology and product interventions to allow users to be more sustainable (Lilley, 2009; Lockton et al., 2008). Energy-saving appliances and vehicles may enable users to maintain similar behavioural patterns and consume less resources. For example, a dish washer with an energy saving option gives users an alternative to carry out a more sustainable practice.

These complex issues ask for flexibility in the designer's ability to determine appropriate means of designing for behaviour intervention (Chapman, 2009). This research will examine current theories and their applicability to the design process.

1.1 RESEARCH PROBLEM

In recent years, there has been an increasing interest in the designer's role in producing more sustainable products and systems (Bhamra, Lilley & Tang, 2011; Braungardt et.al, 2007; Chapman, 2009; Lilley et al., 2006). Accordingly, there is growing interest in the area of research that provides frameworks and approaches to design for sustainable behaviour. The studies that are particularly useful to design research and practice not only propose frameworks, but also document how the frameworks are applicable to the design process. However, such research has only recently been documented (for example, Bhamra et al., 2011; Lilley, 2009; Clune, 2010; Jelsma & Knot, 2002). Therefore this thesis will carry out a design-led research process to examine the applicability of possible sustainability frameworks and approaches to the design process.

1.2 CONTEXTUAL BACKGROUND

An area of pressing concern with respect to sustainability is food waste. Issues surrounding food waste include related emissions from organic waste disposed of in landfill, loss of potentially valuable food resources, the wasted embodied energy of food production, and potential costs to society (Nahman, de Lange, Oelofse & Godfrey, 2012; Cederberg & Sonesson, 2011). Furthermore, in the current landscape of food resources, we encounter a dichotomy whereby developing countries face significant food shortage, while mid- to high-income countries produce large amounts of food waste.

Food waste is often categorised into two areas; post harvest waste and post consumer waste. Post harvest waste relates to food waste that derives from harvest to the time it is purchased by the end consumer. In this phase, food waste results from issues such as food spoilage during storage or transport, which is an area of significance, particularly in developing countries (Parfitt, Barthel & Macnaughton, 2010). In contrast, in mid- to high-income countries, including New Zealand, post harvest waste is highly related to food production and the supply chain (Gustavsson & Lunqvist 2012). Aesthetic defects to fruits and vegetables, waste from food processing, such as trimming scraps, and damage from transportation add to post harvest waste (Gustavsson & Lunqvist, 2012).

However, in mid- to high-income countries, post consumer waste outweighs the post harvest waste (Nahman et al., 2011). Post consumer waste refers to the phase of the food life cycle after consumers purchase food. It is argued that this is largely due to consumer behaviour (Godfray et al., 2010). User behaviour and everyday practice directly relate to food disposal in mid- to high-income countries (Evans, 2012). Accordingly, the commonly referenced data indicates that roughly thirty one per cent of food purchased is thrown away in the United Kingdom (WRAP, 2009 cited in Evans, 2012; WRAP, 2008 cited in Nahman et al., 2012). The urgency to address issues of food shortage and post production complications in developing countries must be acknowledged. However, the current landscape of food waste that is largely the consequence of user behaviour in mid- to high-income countries is directly relevant to this research.

Designing interventions to reduce food waste through exploring user behaviour is a design brief increasingly prevalent in industrial design (for example, Jelsma & Knot., 2002; Electro Lux, 2012). However, to the best of my understanding, to date, there has been little application of a social practice approach to design interventions for food waste. In particular, Shove's Comfort, Cleanliness and Convenience (3Cs), explained further in Chapter 2.4, which explores everyday norms and their contribution to sustainability, will be closely examined for their suitability to design. Therefore, this research will focus on the area of post consumer waste as a context to explore the applicability of Shove's 3Cs for design for sustainable behaviour.

1.3 RESEARCH AIMS AND OBJECTIVES

The research questions and related objectives that structure this thesis are the following.

Research Question 1

What are the current approaches and frameworks to enable design for sustainable behaviour?

Objective: To identify appropriate frameworks and approaches for design for sustainable behaviour.

Research Question 2

Can the selected sociological sustainability approach, Shove's (2003a) Comfort, Cleanliness and Convenience (3Cs), be extended to the wider design for sustainability context?

Objective: To explore the applicability Shove's 3Cs in food waste context.

Research Question 3

How do Shove's 3Cs inform design for sustainable behaviour in a wider sustainability context?

Objective: To examine the applicability of Shove's 3Cs in the design process to reach interventions that encourage sustainable behaviour.

1.4 STRUCTURE OF THIS STUDY

This thesis is arranged into eight chapters.

Chapter 1 provides current research problems and the context of this research, and outlines the foundation of this thesis.

Chapter 2 reviews relevant literature to investigate appropriate methodologies, frameworks and approaches for sustainable behaviour. An interdisciplinary approach is taken in this review to identify multiple areas that could be applied to the design process.

Chapter 3 discusses the research design by outlining relevant studies in design-led research. Human centred design will direct the steps for this research, which are presented in this chapter.

Chapter 4 reports on the pilot observation, which explores research question two and its related objective. This chapter also provides an opportunity to examine the applicability of observation methodologies. An analysis of the observation contributes to forming a strategy for the following major observation.

Chapter 5 presents the findings and related discussions for the major observation. The insights gained from this chapter will be assessed to frame a design brief.

Chapter 6 applies the design brief for the design ideation phase. This phase attempts to create a range of design intervention possibilities, which are then refined into three concepts. This chapter also evaluates the limitations of the design concepts and examines them against relevant design for sustainability theories.

Chapter 7 discusses the links between the design for sustainability frameworks and approaches and their applicability to the design process and summarise the research findings.

Chapter 8 offers conclusions on how design for sustainability frameworks can inform design for sustainable behaviour. Recommendations are proposed to suggest future design for sustainability research and design practice.

1.5 DEFINITION

1.5.1 DESIGN FOR SUSTAINABLE BEHAVIOUR

This research makes reference to Debra Lilley's paper, "Design for Sustainable Behaviour: Strategies and Perceptions" (2009) which provided useful language and concepts for this research. Design for sustainable behaviour in this research relates to Lilley's explanation of the area of study: "research exploring how design could be used to influence user behaviour towards more sustainable practices" (Lilley, 2009, p704). This research also takes cues from a number of related areas of research that apply Elkington's (1998) Triple Bottom Line for sustainability with respect to environmental, social and economic dimensions (Thorpe, 2010; Clune, 2010; Lockton et al., 2008; Chapman, 2009; Bhamra & Lofthouse, 2007).

CHAPTER TWO: LITERATURE REVIEW

2.0 LITERATURE REVIEW

This chapter examines various conceptual frameworks and approaches on behavioural interventions and sustainability. The intention is that this review will shed light on ways that the behavioural intervention and sustainability frameworks can enrich the process and outcomes of design for sustainable behaviour, so that these can be employed in subsequent research.

2.1 SUSTAINABILITY DESIGN FRAMEWORKS

Design for sustainability frameworks are vital for various stages of the design process to generate more sustainable design outcomes. The two design for sustainability frameworks commonly discussed in design research are Cradle to Cradle (C2C), and Life Cycle Analysis (LCA). C2C takes cues from the aspect of ecology in nature, where waste is taken up as a nutrient. LCA, on the other hand, is a quantitative analysis that seeks to calculate the environmental impact of the life cycle of a product. This section will discuss these frameworks with relevance to design for sustainable behaviour.

2.1.1 CRADLE TO CRADLE (C2C)

Cradle to Cradle (C2C), also known as Eco-Effectiveness, draws on the cyclic quality of nature, where waste is used up as a nutrient (Braungart, McDonough, & Bollinger, 2007). There is no waste in nature. Therefore, C2C is a goal-driven approach that considers ways to design products where, at the end of a product's life, the materials of the product become material for another product (Rossi, Charon, Wing, & Ewell 2006). By considering cyclical material flow systems and material quality and productivity over time, a product can be designed to be more sustainable. Besides biological waste the C2C framework also accounts for non-natural technological waste, which cannot be put back into nature. Taking into consideration technological waste that can be recycled back into new products allows this framework to prompt economic growth and innovation. Further this framework can be useful for products with short life spans (Shedroff 2009). For this reason the C2C framework is also a valuable tool towards designing more sustainable products for a commercial sector (McDonough & Braungart, 2009).

C2C's goal-oriented approach to sustainability is useful during the design process. Further, some practical strategies that embody C2C's values are worth consideration for design for sustainability. These practical strategies include the idea of "up-cycling" rather than "down-cycling". Down cycle makes reference to some materials, such as paper, where the quality of the material degrades each time it is recycled. Therefore, materials that can be "up-cycled", which maintain the characteristic of the material after recycling, for example aluminium, is preferred. Another useful strategy is to aim to eliminate "monstrous hybrids" that are composite materials that cannot be disassembled at the end of life for recycling.

Currently, there are only a handful of studies that evaluate the effectiveness of incorporating the C2C framework into the design process. One of the few evaluative studies is by Bakker, Wever, Teoh, and De Clercq, (2010). This study argued that C2C sets an ambitious objective for a design project, but little emphasis is given to the actual energy consumed throughout the life span of a product. A Life Cycle Analysis carried out for a garment industry showed that the use phase of a product accounted for 80% of the total energy impact. In this case, therefore, designing for ways to reduce energy consumption throughout the use phase would lead to more meaningful change to the environment (Bakker et al., 2010). Further, De Clercq (2008) cited in Bakker et al., (2010) highlights the difficulty in ensuring that a product is disposed and up-cycled as intended in production.

"Implementing closed-loop material flow required commitment from and monitoring of all material suppliers, manufacturers and production facilities, which is often a too intensive overhaul for business." (De Clercq, 2008 cited in Bakker et al., 2010, p5)

This study, illustrating the limitation of designing a product solely with consideration to the C2C framework, suggests taking both C2C and LCA into consideration in designing for sustainability.

2.1.2 LIFE CYCLE ANALYSIS (LCA)

Life Cycle Analysis (LCA) is a quantitative sustainability framework, that measures the environmental impact of a product. The quantitative data is collected through considering energy and material use in every step of the lifecycle of a product from raw material, production, transportation and disposal (Shedroff, 2009). The data is useful for design for sustainability in forming a brief as well as in the evaluation of a design concept. For example, in the study by Sherwin et al., (1998) the LCA carried out for kitchen appliances indicated the greatest environmental impact was during the use phase. Accordingly, this data was instrumental in narrowing the brief for this project. Applying LCA data to form a brief eliminates guesswork and can lead to products that make an environmental impact in relevant areas.

Further, LCA is a valuable tool in the evaluation of a design concept. For instance, Jelsma & Knot's (2002) study explained a concept to shift domestic clothes washing into commercial systems. Here, two scales of concepts were designed and evaluated through LCA. The result confirmed that their concept would indeed make a positive environmental impact, with small-scale and large scale concepts showing 30% and 70% decreases respectively (Jelsma & Knot, 2002). Carrying out this assessment at such a stage of development would help to evaluate the effectiveness of the design concept before the implementation phase. These examples illustrate the relevance of LCA during the design process. An assessment performed at the beginning of a design process would indicate meaningful areas for design while assessment carried out to evaluate a concept can indicate the possible impact on the design concept to the environment.

On the other hand, a number of limitations of LCA have been pointed out in relation to design for sustainability. Firstly, LCA asks for a large amount of information for assessment, making it both time consuming and costly to conduct. For this reason, small organisations and individuals are often unable to carry out the LCA process. Furthermore, larger organisations that carry out LCA do not disclose their findings. Shedroff (2009) notes the lack of documentation and information made available by

organisations that actively perform LCA. The lack of available LCA information affects both consumers and designers. The LCA information made publicly available helps consumers make informed choices. Similarly LCA information can act as a gauge for design for sustainability practice in multiple ways that range from forming a brief to assigning appropriate materials, transportation and the disposal process.

Another limitation of LCA is that a complete analysis cannot be carried out until a product is in the market, in order to consider embodied energy in transportation. This means that, when considering details, LCA data is highly localised and data collected from one area may not be relevant to another. However, more simplified Streamlined LCA method can be an effective tool to identifying the major issues relating to a product. Streamlined LCA can identify eighty percent of the full LCA data in shorter time and fewer resources (Lockrey, 2011). Therefore, streamlined LCA may be useful tool to inform the design process.

Some researchers also argue that LCA is limited to quantifying environmental, and consequently financial, aspects of sustainability and it does not address social or cultural sustainability. This issue is reflected in the argument by Thorpe, (2010) who believes there is currently a large emphasis given to the end-of-life phase of products, however there is little information available on the social and environmental consequences of manufacturing these products (Thorpe, 2010).

For the scope of this thesis, previous LCA studies are useful in displaying that the use phase of product lifecycle can lead to significant environmental impact (Lockrey, 2011, Jelsma & Knot, 2002., Sherwin et al., 1998). For example Lockery's study of reuse cups identified that the environmental impact was variable depending on how users washed the cups. Washing the cup with cold water would have significantly lower impact than filling a large sink with hot water and detergent. The user behaviour and ways in which they interact with products during its lifecycle is a significant area of study for design for sustainability. The next sections examines the area of behaviour to identify approaches that may be useful for the design process.

2.2 RELATIONSHIP BETWEEN ATTITUDE AND BEHAVIOUR

Until recently, education and raising awareness have been a common approach in encouraging behaviour change (McKenzie-Mohr, D., 2000). The assumption, that people's knowledge leads to concern and subsequently to pro-environmental behaviour, is recognised as Attitude Behaviour Relation in the field of psychology (Ajzen & Fishbein, 1977). This form of intervention has been widely practised internationally, especially by government bodies. However, growing concerns have been raised about the ineffective nature of informing people as the only form of intervention for altering behaviour (Hargreaves, 2011). The following studies reveal cases where raising awareness did not lead to the desired outcomes.

One of the earliest studies of this kind carried out with respect to environmental sustainability was by Geller in 1981, cited in McKenzie-Mohr, (2000). This study showed that informing participants of sustainable issues in a workshop scenario enriched their knowledge base. However, no significant change was observed in their subsequent behaviour (McKenzie-Mohr, D., 2000). Staats (1996) also reported a study where a campaign to inform people about greenhouse effect successfully raised awareness, but did not lead to behavioural change. More recently, Kaskinen, Kuittinen, & Neuvonen's, (2009) study found that, in Finland, 80% of people from diverse backgrounds reported that they were ready to take personal actions against climate change. But contrary to the author's assumption, a rise in household energy consumption was reported.

An opposing position is illustrated by Mobley, Vagias, & De Ward (2010). This study showed that those who previously read three "classic environmental books" reported engaging in more environmentally sustainable behaviour. However, the limitations of this study included the fact that those who were more interested in sustainability issues may have chosen to read the books. In addition, the self-reported nature of the survey is a weaknesses in illustrating the reality of behaviour (Mobley, et al., 2010). Although this study indicated the relevance of raising awareness, it does not prove that the participants' literary experience alone directly affected their behaviour.

These studies demonstrate the complex nature of behaviour, which requires further investigation. Contrary to the Attitude Behaviour Relations explained earlier, behaviour may be influenced by a large number of external factors (Froehlich, Findlate, & Landay, 2010). These issues emphasise the importance of assessing external factors that are relevant to behavioural interventions for design for sustainability. The following section investigates the areas of behaviour that are relevant to design for sustainability.

2.2.1 TYPES OF BEHAVIOUR FOR SUSTAINABILITY

Behaviours for sustainable interventions are commonly divided into two parts; efficiency behaviour and curtailment behaviour. First, efficiency behaviour, is related to one-time commitment that provides a long-term impact (Abrahamse, Steg, Vlek, & Rothengatter, 2005). This behaviour, often related to technological or structural improvements, include purchasing a fuel efficient vehicle or installing a compost bin. The second, curtailment behaviour, involves change in behaviours that are rooted within everyday habits and routines (Kaskinen et al., 2009). For instance, modifying behaviour from driving a vehicle to taking a bus or taking shorter showers (Abrahamse et al., 2005).

The sustainability impact of efficiency behaviour is considered to be greater than that of curtailment behaviours (Froehlich et al., 2010). For example, a one-off commitment to install energy efficient light bulbs is more effective than remembering to turn off the lights (Abrahamse et al., 2005). However, efficiency behaviour may be related to financial commitment, such as purchasing an energy efficient washing machine, which may place limitation on this behaviour (McKenzie-Mohr, 2000). Further, interventions for efficiency behaviours are criticised for the rebound effect, where the unintended use of products lead to negative sustainability impact (Abrahamse et al., 2005). In this research, participants were given a smart meter to monitor their energy use. Rather than reducing their consumption, some used the monitor to meet their usual quantity. At times, some increased their consumption when attempting to meet the usual quantity but instead incorrectly monitored their energy use (Abrahamse et al., 2005). This indicates the complexity of attempting to alter efficiency behaviours.

Some also argue that the technology encompassed by efficiency interventions, such as a energy efficient car, takes responsibility of sustainability issues away from users, while some users may feel manipulated by the product (Lilley, 2009). In contrast, LCA of products, such as appliances, indicates that the use phase is the largest contributing factor to environmental impact (Bhamra & Lofthouse, 2007). User behaviour, for instance, to dry out clothes on the lines rather than in a clothes dryer, leads to positive environmental impact. This suggests that designing for ideal curtailment behaviour is an important part of design for sustainability. Therefore, both efficiency and curtailment behaviours are essential for design for sustainable behaviour. For example, composting organic waste requires the initial commitment to install a suitable waste disposal system. The success of this disposal system is then dependant on curtailment behaviour to follow appropriate ways of disposing of waste. The importance in developing interventions for both behaviour types opens a vast scope of possible areas of research.

2.2.2 PLURALISTIC APPROACH

Recent studies have highlighted an increasing interest in applying pluralistic and interdisciplinary approaches to behavioural interventions. The study central to this review, by Ann Thorpe, (2010) emphasised the importance of broader research, underpinning the diversity of influences for behaviour. In her paper, she approaches the areas of environmental policy, psychology and sociology as basis for building a relevant knowledge base for design for sustainability (Thorpe, 2010). This view has been supported by a number of researchers in design for sustainable behaviour (Chapman, 2009, Lilley, 2009).

A number of key studies indicate the benefit of a pluralistic approach. First, pluralistic approaches are commonly arising as a response to unsatisfactory outcomes from singular intervention models. Some studies of less long-lasting interventions include financial incentives and technological improvements as single sources of behavioural intervention. For instance, a study by Abrahamse et al.(2005) suggests that

financial incentives altered the behaviour only for the duration the incentive was offered. This illustrates that short-term financial incentives do not lead to long-term behavioural change. In contrast, a study that examined the effect of multiple interventions for reducing energy consumption showed reduction in energy use and increased knowledge on their consumption patterns (Abrahamse, Steg, Vlek, & Rothengatter, 2007). These research indicate that multiple intervention approaches are more effective to lead to longevity of behavioural change.

Second, relying on technological innovation alone as a form of intervention for sustainability is questioned. Lilley et al. (2005) uses energy rating for a washing machine as an example. If a washing machine is given an ideal energy rating with a 40 degree wash option, using the higher temperature options may have no meaningful effect on the environment. In this case the user may be reassured by the knowledge of owning a sustainable product when the reality may be otherwise.

Third, a number of design for sustainability researchers suggest the benefit in gathering various intervention frameworks as a potential guide to the design process (Lockton et al. , 2008). This reflects the nature of the design discipline, where strict prescriptive methodologies are rarely utilised (Verganti, 2003; Cross, 2006). The application of various intervention frameworks as potential guides during the design process was evident in research by Lilley (2009). In this research, three behavioural intervention frameworks eco-feedback; behavioural steering; and persuasive technology - were introduced to industrial design masters students to apply to their project. Their outcomes illustrated that the students used the frameworks to guide their concepts or to evaluate the effectiveness of their design ideas, but the frameworks were not used as strict methodologies (Lilley, 2009).

Further, several studies in design for sustainable behaviour also discuss multiple considerations for behaviour intervention from various areas. Recent papers showed two main areas of focus. The first is the sociological approach. This approach investigates such areas as social policies, consumption patterns and everyday habits and routines to seek possible strategies for change (Thorpe, 2010; Shove,

2003a). The other is the product-led approach to produce appropriate products for positive sustainable impact. The studies in this area commonly explore ways of assisting more meaningful interaction between artefacts and users to improve products or services (Lockton et al., 2008; Sherwin, 1998). In both of these cases, no one single perspective is prescribed as a methodology. Rather, an array of behavioural intervention frameworks are introduced and assessed as possible guides or directions for sustainable behaviour (Lockton et al., 2008).

An opposing view is highlighted by Stegall (2008). He states that “A time has come to develop a unifying ecological design philosophy...” (pp.63). He urges that a united philosophy in resources, form, function, purpose and human spirit could be a key driving force to shape an ecologically sound society (Stegall, 2006). However, as a proposal for the unified philosophy, he argues for the importance of promoting sustainable behaviour and the need for designers to acquire a broad range of knowledge that covers “Science, art, engineering, communication and human interaction (Stegall, 2006, pp.63).”

A similar view is evident in the study by Chapman((2009) who states: “ This pluralistic approach leads us toward a more nuanced sustainable design culture, in which essential debate begins to unpack, question, and explore new ways of working with issues of sustainability through design” (p. 29). Fletcher (2007), in support, argues that; “We are not looking for mass answers, but instead a mass of answers.” (p.130). Indeed, catalysts for sustainable behaviours are embedded in a vast array of disparate contexts. Design for sustainable behaviour is therefore most effectively researched through a pluralistic approach, rather than by seeking one possible answer to all problems.

The following sections introduce several key areas for design for sustainable behaviour. Section 2.3 reviews the studies in the area of product-led behaviour interventions, seeking to encourage meaningful interactions between users and products. Section 2.4 then outlines research that examines sociological approaches for ways in which everyday norms become embedded into our lives.

2.3 PRODUCT-LED INTERVENTIONS

Product-led behaviour interventions are an increasingly important area in design for sustainable behaviour. On-going advances in technology contribute to a vast range of possibilities that may prompt users to behave in more sustainable ways. Further, some technologies allow users to maintain a usual behaviour while decreasing their impact on the environment. On the other hand, non technological strategies for product behaviour change are also apparent.

This section discusses three broad areas of product-led behaviour interventions: prompts, behaviour steering, and intelligent products. These areas of behaviour interventions tend to overlap depending on the author due to the intertwined nature of this area. Therefore, this section will focus on the relevance of the intervention frameworks for design for sustainable behaviour.

2.3.1 ECO-FEEDBACK

Eco-feedback is a framework that advocates the provision of information or “feedback” to users to alter their behaviour to reduce environmental impact (Froehlich et al., 2010). Key to the framework is providing information at a most opportune moment, which is local to the action (Clune, 2010). Eco-feedback is typically applied to energy consumption, water usage, transportation, and waste disposal practice. Kohlenburg et al., (1974) cited in (Froehlich et al., 2010) carried out the earliest of this kind of study where a light bulb was installed that lit up when a household was within 90% of their peak energy levels. The behaviour of occupants altered as a result of the illuminating light bulb’s informing them of their energy consumption (Froehlich et al., 2010).

A contemporary to this concept is the eco-feedback device, often referred to as Smart Meter. Smart Meter uses technology to measure and provide real time or near real time information on electricity, gas and

water usage in homes and businesses (Froehlich et al., 2010). It is intended that the information provided by this technology will enable users to make informed choices and alter their behaviour accordingly. As a result, the importance of displays on Smart Meter is often discussed. This technology is particularly effective when it provides various sources of information such as volume and cost of energy use overtime to prompt user behaviour (Froehlich et al., 2010). Another important aspect of the Smart Meter is its strategic placement within a household or a business, where the information can be readily accessed at the time of decision making (Lockton et al., 2008).

Another commonly discussed example of eco-feedback is the Kambrook Axis Kettle. A Life Cycle Analysis of a kettle indicated that the use phase displayed the most negative environmental impact. This was due to users' tendency to forget they have already boiled water and re-boil water. Re-boiling it consumes energy that could be conserved (Lilley et al., 2006). As a form of eco-feedback intervention, a thermostat was added to the kettle to inform users of the temperature of the water. This feature in turn allows a user to make an informed decision whether to re-boil the water (Lilley et al., 2006)

Two areas of concern are raised for the eco-feedback approach. The first is the interpretation of the information provided to the user. Providing information alone may not result in a change of behaviour. In the case of the Axis Kettle, users may need to be made aware of the energy consuming nature of the electric kettle and the acceptable range of temperature of water in order to steer them away from re-boiling (Lilley et al., 2006). Lilley et al. (2006) suggests that some users may need assistance in interpreting the feedback in relation to their behaviour. This implication leads to the next concern, where providing information alone does not support behaviour change effectively. In supporting the pluralistic approach (section 2.2.2), additional intervention frameworks would aid the favourable outcome of eco-feedback. The eco-feedback concept in Clune's (2010) paper is explained as a form of prompt. Eco-feedback is at times associated with prompt and behaviour steering. The next section investigates the area of behaviour steering and its relevancy to design for sustainable behaviour.

2.3.2 BEHAVIOURAL STEERING

Behavioural steering is a term for a series of conceptual frameworks, which seek ways in which products can encourage sustainable behaviour and discourage unsustainable behaviour. This term, proposed by Jelsma & Knot (2002), recognises the possible disconnect between a user and an artefact, and seeks to connect these two important foci in design for sustainable behaviour. These frameworks often relate to Donald Norman's theory on affordance and constraints, including perceived affordance (Norman, 1999). It will be discussed in turn; the area of prompts, affordance and scripts, followed by assessment into frameworks of constraints.

2.3.3 PROMPTS

The concepts of behaviour steering with use of prompts, affordance and scripts attempt to connect the user with products in a way that encourages desired behaviour and reduces unintended behaviour. For the purpose of this research the term "prompts" will be used to describe this concept. Prompts may be given by physical appearance, functionality interface or size of the product.

First, the classic example of offering prompts is that of the physical appearance of a door handle, where a metal plate indicates pushing the door and handle indicates pulling the door (Clune, 2010). The doorplates and handles encourage the user to interact in behaviour intended by the designer. Similarly, a cultural norm can also be presented through physical appearance. Clune (2010) explains that a house with shoes at the door allows visitors to pre-empt the custom of the household and accordingly take off shoes before entering.

Second, prompts may be offered in the form of an interface. An adjustable temperature interface on a fridge or washing cycles on machine enables a user alter the way the appliances perform to suit their washing load. These prompting tools were vital for resolving an earlier discussion on AA energy rating

washing machines. Section 2.2.2 discussed Lilley et alia's (2006) finding that washing machines given an AA rating at 40 degrees gave a false impression of its overall performance. These types of problems may be clarified by offering prompts as an eco-option to run the washing machine with a function that ensures the optimal use of water, detergent and energy (Jelsma & Knot, 2002). However, as consumers become more aware of sustainability issues, the question of the meanings behind these eco-options may arise. Additional information therefore becomes an integral part of products with such functions.

Finally, prompts may be offered through the size of objects. Classic examples of these prompts are laptops and mobile phones which enable the users to interact with these devices in a different way than with previous larger devices (Lilley et al., 2006; Froehlich et al., 2010). Unilever also used this form of prompt as a result of finding out that users were inclined to over use detergents for dishwashers. This detergent in tablet form allows users to administer the optimal amount (Lilley et al., 2006). The nature of these products reveal the close relationship between prompts and constraints in product intervention for design for sustainable behaviour (Lockton et al., 2008).

2.3.4 CONSTRAINTS

As illustrated by the Unilever detergent tablet, constraints are applied to artefacts as a way of preventing undesirable or unintended behaviour (Lilley et al., 2006). Some of the commonly discussed constraint features include mechanisms, and as previously discussed, size of products. Mechanisms as constraints are often applied to increase the safety of a product. For example, devices such as food processors offer constraint in the form of a lock on a cover so that a user's hand has no access to the blade while it is turning. In relation to sustainable behaviour, Lockton et al., (2008) suggests that constraint may be used as a form of rationing. For instance, coin-operated electricity implies that a relatively unlimited resource is limited, and has an effect in preventing users from using more of a resource than necessary (Lockton et al., 2008).

Size constraint in a similar way to size prompt, another commonly applied framework of steering behaviour. An example includes the Quick Cup kettle, which was designed as a response to users filling kettles with more water than needed (Lockton et al., 2008). This kettle is a single serve size that encourages or constrains the user to boil the appropriate amount and consume only the energy required. A similar concept is Poka-Yoke, which seeks to prevent mistakes by users through the use of warning lights, buzzers or information displays (Lockton et al., 2008). Two forms of Poka-yoke were developed by Shigeo Shingo, cited in Lockton et al., (2008) for the context of the Toyota Production System. One is the Control Poka-yoke which “makes it impossible or difficult to proceed until error is corrected”(Lockton et al., 2008, p5). For instance, an interlock on a car efficiently locks all doors to prevent any one of the doors being left unlocked. This concept is further applied to design for sustainability products in the form of automatic lights and water taps to prevent consumption when users are not present (Lockton et al., 2008). The subsequent Warning Poka-yoke uses lights, buzzers and information display to alert users of any complications. In the context of a car, the buzzers may alert users to turn off head lights when the key is taken out of the ignition. This form of Poka-yoke enables users to act in a way that prevents further complication to the product (Lockton et al., 2008). The limitation of these warnings is that when activated too frequently users may become complacent or annoyed. In turn, these warnings could prove less effective when users do not take appropriate steps to counteract the warnings.

2.3.5 INTELLIGENT PRODUCT INTERVENTION

Further developing the concept of prompts and constraints with technological advance is the framework of intelligent product interventions. This framework often does not require users to alter their behaviour but rather develops products that consume less energy while allowing users to continue performing their embedded behaviour. (Lilley et al., 2005). This section will discuss two such interventions, one a concept for a washing machine and the other, the Honda Integrated Motor Assist.

First, Jelsma & Knot, (2002) argued the benefit of incorporating intelligent product intervention as part of a washing machine. Their use research about cleaning clothes with relevance to energy consumption

found that washing loads can be different from the optimal load for a machine. For instance, a load of washing could be in between small and medium, in which case using the medium load option consumes excess water and energy. In addition, carrying out urgent washing in small loads may use more water and energy than necessary. These issues of washing load bring into question the ineffective nature of the interface that prompts users to choose the size of the load without additional information. Supplementary information is necessary for users to gauge the size of the washing load relative to the washing machine in use. On the other hand, Jelsma & Knot (2002) responds by suggesting the incorporation of intelligence into washing machines. The intelligence could automatically weigh the load and use water and detergent accordingly as a sustainable product intervention (Jelsma & Knot, 2002).

Honda Integrated Motor Assist System in the same way uses intelligence to reduce energy consumption. This system automatically turns the engine on and off at traffic lights to reduce energy consumption and emissions (Lilley et al., 2006). This intervention does not ask for users' behavioural change but the intelligence enables them to reduce environmental impact. As a result, Lilley et al (2006) raises the complex issue that some intelligent product interventions take responsibilities away from users. This, in turn, also presents question of the responsibility of designers for sustainable products.

2.3.6 EMOTIONAL DURABILITY

A contrasting approach to technology interventions to reduce sustainability impacts during the use phase of the product life cycle is Emotional Durability (Chapman 2009). Appropriately designed products, which can engage emotional attachment from users, may encourage longer use time (Chapman, 2009). Prolonging the use phase of products is a significant area of consideration in the current landscape of throw away consumer society. Therefore, this study proposes a number of design considerations that may lead to designing products that generate emotional attachment by the users, including embedding narrative into product, and considering surface wear (Chapman 2008).

This framework resonates with Dieter Ram's Ten Principles of Good Design, which considers environment and designing products that are long-lasting and functional (Lovell & Kemp 2011). This may be similar to "detachment" aspect of the frameworks proposed by Chapman (2008), which suggests that even when a user is emotionally "detached" from a product, if the product is functional and does not date in fashion, it will continue to be used (Chapman 2009). Further, Dieter Rams's principle, products should be aesthetic and innovative, relates to Chapman's Attachment, which suggests that "Users feel a strong emotional connection to the product, due to the service it provides, the information it contains and the meaning it conveys." (Chapman, 2009, p 33)

The emotional durability is primarily intended for technological products. However, a recent study by Lacey (2009) who explored the relevance of the framework to ceramic coffee cups. This study identified the importance of issues such as eliciting surprise through a product. In addition, offering choices through the angle of handles that prompted users' for conscious engagement with the product and led to emotional durability as users found angles of handle that personally suited their way of use (Lacey 2009). Nam and Kim, (2011) who explored the application of narrative to digital technology, also suggested this is a worthwhile area of further research. However, this study also explained the limitation of surprise or special features, which are difficult to replicate for users after the initial experience. These studies indicate that emotional durability frameworks may be applied to various forms of products to contribute to designs that generate emotional connection to users for longevity of use.

2.3.7 LIMITATIONS OF PRODUCT INTERVENTIONS

Product-led interventions are criticised for a number of reasons. These include the rebound effect, when unintended user behaviour leads to negative environmental impact (Froehlich et al., 2010), as discussed in section 2.2.1. The second issue is the non-fail-proof nature of the intervention. An example of a non-fail proof intervention is a car seatbelts where the designer is unable to force a user to comply with the intention. Lilley et al., (2005) argues that "... a driver could choose not to fasten their seatbelt and, short

of designing a car which would not start unless seatbelts were fastened, the manufacturer has no further recourse”(p.6). In addition, product-led interventions are usually based on the designers’ interpretation as to how users may interact with the product. As a consequence, Jelsma & Knot (2002) argue for the importance in understanding users’ values and logic. Further, he urges designers to question why and how users interact with products as a starting point to their design intervention (Jelsma & Knot 2002).

The shortfalls of product intervention also point to the moral issues raised in response to technological advance in products. Two areas of discussion have arisen: the issue of taking responsibility away from the users and consideration of the relationship between users and products. Products such as the Honda Integrated Motor Assist System discussed in section 2.3.5 illustrate the limited change in user behaviour to reduce energy consumption. Product-led interventions that enable current consumption patterns while reducing energy consumption support the current consumption cycle, so the financial sustainability of corporate sectors must also be taken into account (Lilley, 2009).

In contrast, the relationship between products and users was raised by Lilley (2009). This study applied intelligent product interventions to mobile phones to discourage undesirable behaviour. The participants in this project suggested that when this form of intervention was applied for the benefit of user safety, it was acceptable. However the participants expressed a view that products should obey user, and not the other way around (Lilley, 2009). These studies revealed a number of ways of designing interventions through products, which also unveiled the complexity of the relationship between sustainability issues, designers’ intentions, product capabilities and the end users.

2.4 CAUSES FOR NORMALITY

One approach to designing for the environment is to trigger a change from everyday norms ingrained in habits and practice to ones that are more sustainable. Uncovering the current norms of a particular everyday activity that is energy consuming may be beneficial in finding effective ways to introduce

alternatives. In sustainability issues such as water conservation, understanding the meanings around activities that consume water may trigger strategies to reduce the use of water (McKenzie-Mohr, 2000, Shove, 2003). Similarly surveys of historical progressions that have led to forming everyday norms may reveal strategies for ways in which a cultural group adapts to a new form of norm (Shove, 2003). In both cases, when a positive change to environment is adapted by a significant proportion of the population to become a norm in a cultural group, a far-reaching change can be collectively achieved (Thorpe, 2010). This section discusses three foundations that prompt changes to everyday norms: legislation and standards; changes initiated at the corporate level; and marketing measures. These foundations are then assessed as potential tools for behavioural change, which are used in the experiments of the current study.

2.4.1 NORMALITY THROUGH LEGISLATION

Enforcing legislation and standards can act as a catalyst for altering the norms in everyday consumption patterns. Recent studies showed two areas of concern for design for sustainable behaviour. One such act of legislation was an attempt to standardise temperatures in public buildings, which led to vast social change (Shove, 2003b). The more commonly discussed area of legislation is the so-called Choice Editing, where unsustainable products are edited out by legislative decisions on behalf of consumers (Thorpe, 2010). A study of norms which shifted as a result of these pieces of legislation, may inform design for sustainable behaviour. First, an internationally adopted standard, the American Society of Heating and Refrigeration and Air Conditioning [ASHRAE] Standard 55 (cited in Shove, 2003b) led to a snowball effect of change in norms. This particular standard articulated what is comfortable in terms of temperature for an inside environment. Corporate and institutional buildings first adopted this standard, which changed the behaviour of occupants. Those who felt uncomfortable with the standardised temperature took off or put on layers of clothes rather than adjusting the air conditioning. Subsequently, the standardised institutional temperature along with modified behaviour entered private homes. By this time, this new norm had extended to architectural practices that reduced the need of such features as windows and verandas, which previously ventilated a building naturally. The introduction of air conditioners and newly transformed buildings meant

that people no longer went outside to cool down in summer. This, in turn, reduced social interaction between neighbours. This historical assessment illustrates the potential snowball effect that legislative decisions are capable of causing (Shove, 2003b).

With relevance to design for sustainable behaviour, this assessment reveals that vast social implications were caused through regulation and policies. Therefore, producing a historical survey as a part of human centred design research may be valuable in uncovering the core issues that could enable behavioural change.

Legislation has been effective in shifting the landscape of products on offer to consumers. For example the legislation that prohibited the production of ozone depleting chemicals in aerosols was one of the first of this kind (Thorpe, 2010). More recently, energy efficient appliance models became the norm in the European Union, after governments intervened to remove poor energy efficient products from the market (Chapman, 2009). Thorpe (2010) calls this Choice Editing, where consumers become protected from purchasing, and consequently, utilising products that are recognised as producing negative environmental impacts.

This progression of norms illustrates the possibility of eliminating environmentally harmful products from the consumer market. In relating this to design for sustainable behaviour, it illustrates the importance for designers to endeavour to design products that are as sustainable as possible. When this is practiced by a significant number of designers, a norm for the expectation of products may be shifted. This, however, requires consumer interest in sustainable products. The next section discusses further the implications of a consumer's informed choice .

2.4.2 NORMALITY THROUGH CORPORATE INITIATIVES

In contrast to legislative changes, corporate bodies may also initiate a change in norms. In some cases this allows a corporate body to become the leader in a field of such products (Thorpe, 2010). Toyota's hybrid automobile, Prius, introduced a technology that reduces energy consumption. In this case, consumers'

prior interest in reducing fuel consumption, because of price of fuel and potential rationing due to fuel shortage coupled with effective communication to the public, helped form a new awareness for the technology (Thorpe, 2010). The synthesis between consumer awareness with the manufacturer's ability to introduce a more sustainable technology has a potent affect on rapidly changing the norm of products in the market.

Examples in this and the previous section make apparent the potential of legislative change and corporate initiatives to generate a further change in the norm of consumer behaviour. The introduction of legislation as a result of increased interest in products in the market encouraged consumers to make informed choices. According to Thorpe (2010), the generally accepted objective of informed choice is for consumers to demand sustainable products and, in turn, corporate businesses would respond with supplying what is less environmentally damaging. However, the concept of informed choice has been criticised for its strong marketing influence on consumers, which may sway decision-making (Thorpe, 2010). In addition as discussed in section 2.1.2 with regards to LCA, little quantifiable facts are available to inform consumers. On the other hand, a change in norm of consumption to one that challenges decisions made by corporate and government bodies nurtures the consumption and production of more environmentally sustainable products.

2.4.3 NORMALITY THROUGH MARKETING MEASURES

Marketing is another area that affects the construction of norms. In their study, Lupton & Abbott Millar (1992) discuss one of the earliest examples of marketing efforts that changed norms around consumption. They explain that in as early as 1932 Ernest Elmo Calkins wrote about the importance of encouraging people to use up products to increase the rate of product life cycle. It was emphasised that even products as large as cars should be used up and disposed of like toothpaste, so that more could be sold (Lupton & Abbott Millar, 1992). Through marketing, norms of the product life cycle became dramatically reduced over time as the life cycle of products from production through purchase, consumption and disposal sped up.

The effect of this concept is relevant for consumer culture today. As a response to this culture, Thorpe (2010) urges that non-purchase options should be more readily explored as an approach to design for sustainable behaviour. Prolonging the life cycle of products, while encouraging consumers to engage in non-purchase options where possible, is an important step. However, these two positions reveal a complex juxtaposition between the interests of the corporate sector and the interests of those whose approaches to sustainability do not account for commercial gain. Here, the importance of considering a variety of sustainability issues, including environmental, financial and social sustainability are reinforced.

Marketing has also had a significant affect on the norms of washing clothing. Shove (2003a) argues that fragrance, disinfection and freshness are aspects that have recently become associated with washing clothes, through the marketing of products, such as washing detergents. In contrast, the traditional association between cleanliness and washing with hot water has significantly reduced, which led to a significant positive effects in the reduction of energy consumption (Shove 2003a). An understanding of the cultural norm in this area, and the meanings associated with cleanliness, is important to consider when designing for sustainable behaviour.

2.5 SOCIAL PRACTICE THEORY AND SUSTAINABILITY

Recently, an increasing amount of sustainability research has been carried out through the application of social practice theory. This approach emphasises the move away from studying individual attitudes and behaviours to investigation of social organisation of everyday practices (Reckwitz, 2002; Hargreaves, 2012; Wade, 2009). The studies using this theory point out the limitation of an attitude behaviour relation model (see section 2.2) for isolating individuals' behaviour from elements that contribute to behaviour other than attitude (Spaargaren, 2003; Wade, 2009). A social practice model, on the other hand, "looks into the possibilities for designated groups of actors to reduce the overall environmental impact of their normal daily routines involving clothing, food, shelter, travel, sport and leisure." (Spaargaren, 2003, p668). A social practice model is also suggested by a study carried out for resource management that advocates for "the

need to move beyond demand management programs that follow the logic of resource management and attempt to make existing norms more efficient” (Strengers, 2008, p15). Gaining an understanding of the wider influences of individuals’ everyday norms may identify ways to promote more sustainable norms (Hargreaves, 2011; Spaargaren, 2003; Wade, 2009).

Social practice theory devised from such theories as Pierre Bourdieu’s “Habitat” stems from broader cultural theories (Ropke, 2009). Social practice theory, uses a *Practice* as a unit of analysis:

“A ‘practice’ (Praktik)¹ is a routinized type of behaviour which consists of several elements, interconnected to one other... A practice - a way of cooking, of consuming, of working, of investigating, of taking care of oneself or of others, etc. – forms so to speak a ‘block’ whose existence necessarily depends on the existence and specific inter-connectedness of these elements, and which cannot be reduced to any one of these single elements” (Reckwitz, 2002, p249-250).

2.5.1 IDENTIFYING ELEMENTS OF PRACTICE

A useful analysis of the wider social practices that may be applicable to design is given by Hargreaves (2011). The focus of the theory is defined in three terms: first, building blocks or elements that make up a practice; second, how the elements are connected together to result in everyday practice; and third how the practices extend to everyday norms and their affect on “broader socio-technical systems” and provision of resources (Hargreaves, 2012). Further, Hargreaves (2012) suggests that Shove and Pantzar’s (2005)’s understanding of practices is a useful tool of analysis. In this study, Shove and Pantzar (2005) take cues from Reckwitz (2002) and Shatzki (2001) to argue that “.. practices involve the active integration of materials, meanings and forms of competence” (Shove & Pantzar, 2005, p45). Figure 2.1 displays the three areas of elements of practice. In their study, these three areas of practice are applied to analyse Nordic Walking Practice illustrated in Figure 2.2.

Figure 2.1 Elements of Practice
(Shove & Pantzar 2005)

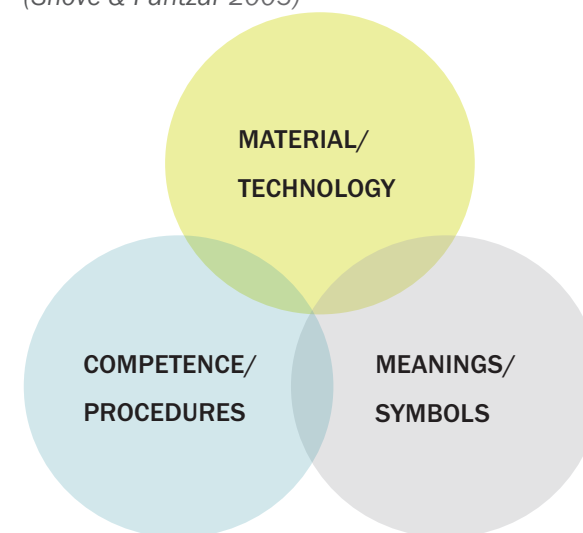

¹ Praktik is a German word for practice

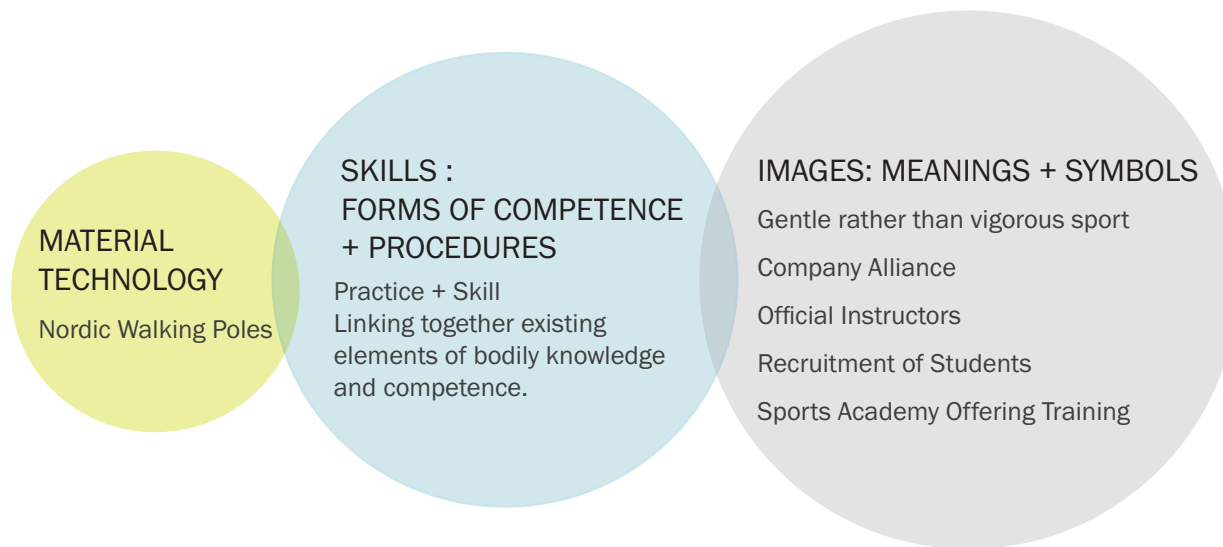

Figure 2.2 Nordic Walking Innovation

The innovation explained through meanings, skills and materials (Pantzar & Shove 2010).

2.5.2 NON- STATIC NATURE OF PRACTICE

Practices and routines are not static. Practices change over time, where current practice is reshaped, while new practices are introduced and some practices vanish. Shove and Walker (2010) explains that it is a “question of how patterns and practices of daily life interrelate, erode and reinforce each other. These are key themes for any understanding of innovation, let alone transition in practice” (p476). This study also uses similar areas of practice to analyse the everyday norms around showering. A schematic generated from their analysis is displayed in figure 2.3. This is an area of great interest for design for sustainability for the reason that through understanding the catalysts for transitions in social practice, current norms may be shifted to more ideal norms to seek to eliminate undesirable practices.

Figure 2.3 Transitions in the Bathroom

An analysis through a social practice approach

(Shove and Walker 2010)

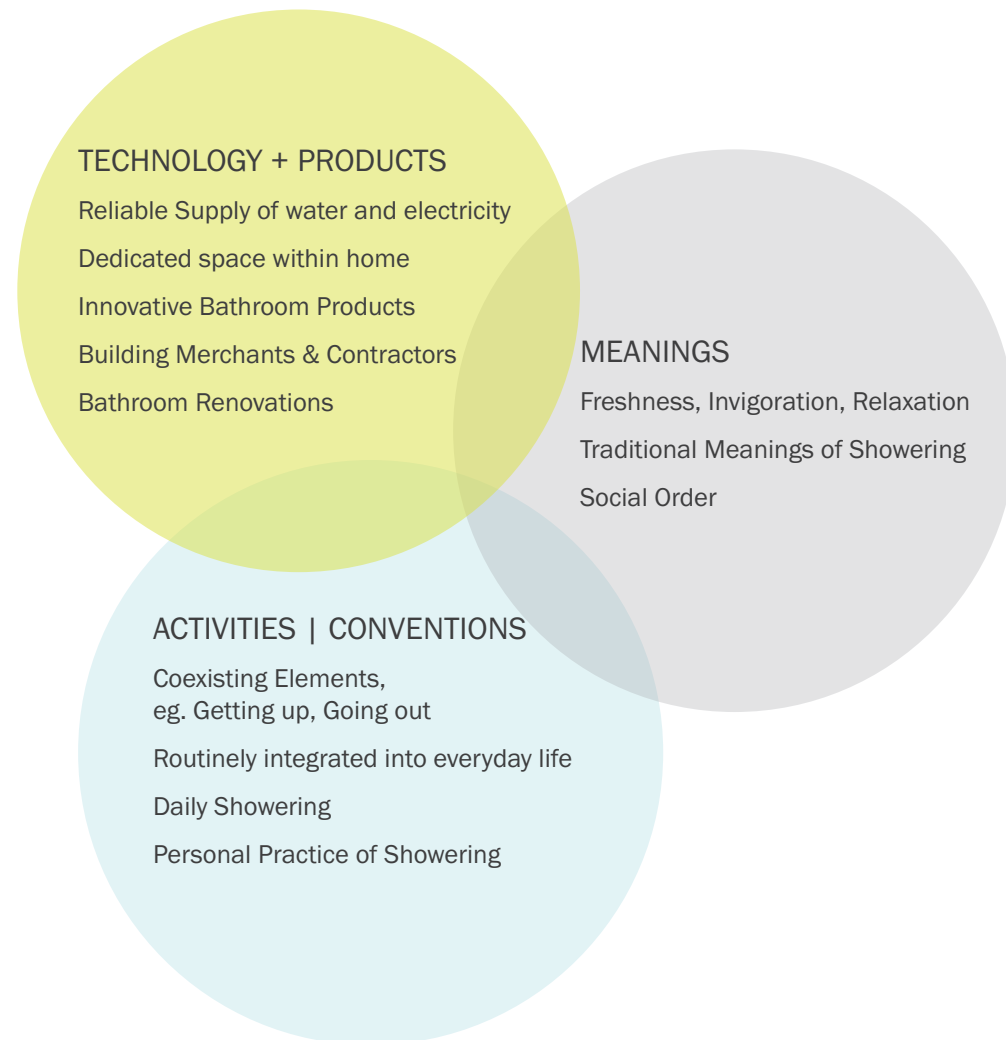

2.5.3 SOCIAL PRACTICE AND DESIGN

The fundamental relationship between social practice theory and design is the way products and services are significant elements of everyday life. Central to Shove and Pantzar's (2005) study was the Nordic Walking Poles, that acted as one of the key elements for wider innovation. Similarly, Ingram, Shove and Watson (2007) voice a similar position, social theories of consumption and practice may be useful tools to engage in as a part of the multidisciplinary design approach. Integrating social practice approaches may benefit a wide range of design outcomes, including experiences surrounding design, and system design, as well as artefacts that are embedded as a part of everyday practice.

This section is intended to briefly introduce social practice theory with relevance to design for sustainability. This thesis recognises of the wider scholarly positions governing this theory. However, as Ingram et. al (2007) suggests, "brutal simplification" of this seasoned theory is needed to begin to understand its applicability to the design process. Therefore, with this introduction in mind, this thesis will focus on a sociological approach, Comfort Cleanliness and Convenience, which may be a useful tool to identify elements of everyday practice and norms (Shove 2003).

2.6 COMFORT, CLEANLINESS AND CONVENIENCE (3CS)

One of the recognised sustainability studies that utilises a sociological approach is Shove's (2003) Comfort, Cleanliness and Convenience. This study argues that;

- a) the 3Cs embedded in everyday norms and rituals are responsible for shifting norms over time;
- b) catering for the 3Cs are resource intensive; and
- c) the 3Cs act as cogs to accelerate the demand for resource intensive conventions.

Therefore, considering the meanings embedded in the 3Cs may be helpful in introducing a shift in social norms that are less resource intensive. With respect to design for sustainability, through understanding how the 3Cs shift norms, can design interventions shift norms to ones that are less resource intensive?

A good example that illustrates Shove's 3Cs is the convention of showering. The overriding meaning of showering is cleanliness, and the expectation within a society to be clean and odour free. However, showering also provides comfort as a therapeutic activity. These meanings are combined with the convenience of the practice of showering. Showering has increasingly become more convenient over time, with improved infrastructure and related material culture. Shove argues that the 3Cs work together as a cog to shift norms and rituals of everyday life and, consequently, increase rates of resource consumption over time. In this case, the norm of the twice weekly shower from a few decades ago has shifted to the norm of once-a-day or even twice-a-day showering (Shove 2003a).

Providing interfaces to support the 3Cs can rapidly increase expectations and accelerate the frequency of consumption. Consequently norms, or a standard of consumption intensifies as Shove states, " I am interested in the escalation of demand and the standardisation of convention" (Shove 2003a, pp80). The 3Cs that are closely connected to everyday rituals, norms and habits may be readily applied to design for sustainability. Further, the ethnographic approach that leads to the 3Cs may be applicable to Human Centred Design strategies. This section investigates the fine nuances of 3Cs with consideration to design for sustainable behaviour.

2.6.1 COMFORT

Comfort is defined in two broad contexts: physiological and social comfort. The practice of showering caters for both contexts of comfort: "contemporary enthusiasm for regular power showering is consistent with an emphasis on image and appearance, on the curative and therapeutic properties of invigoration, and on the distinctive blending of pleasure and duty" (Shove, 2003b, p407).

Physiological comfort is identified as the “curative and therapeutic properties” of showering, while social comfort is related to “an emphasis on image and appearance” and a social responsibility to keep oneself clean. Further, social comfort is explained: “ The external world is a source of judgement and of dirt and other rules apply in defining what can be worn where and when, and in determining the status of things that are clean (having just been washed) but still visibly stained” (Shove, 2003b, pp402).

Everyday norms and actions can be a conscious or unconscious reflection of the social rules of cultures with which individuals identify themselves. This, coupled with the physiological comfort to shower, is insightfully summarised as: “blending of pleasure and duty” (Shove, 2003b p407).

2.6.1.1 DESIGN RESONANCE

DESIGN OF ARTEFACTS AND 3CS

The fundamental need for physiological comfort must be considered when designing products. Further, the current landscape of sustainability interventions for activities are addressed through technological improvements or individual behaviour change (Strengers, 2008). An analysis of design observations through the 3Cs may provide a platform to consider the provision for resource intensive activities through another form of intervention.

SOCIAL RULES AND DESIGN FOR SUSTAINABILITY

Social comfort and social rules are an area of interest to design for sustainability. Gaining an understanding of cultural and social rules, as well as prevailing etiquettes, is central to a human centred design approach. A comprehension of social rules provides a platform for designers to create interventions that are suitable. Further, social rules can be fluid. Some rules become out-dated, while new rules are introduced. The awareness for sustainability and the gradual change to social rules is a prominent example of the evolving nature of social rules (Thorpe, 2010). With a thorough understanding of social rules, designers may take advantage of its fluid nature to introduce a new set of social rules that are more sustainable.

2.6.2 CLEANLINESS

Cleanliness is defined in three contexts: a) hygiene and protection of health, b) hygiene and cultural rules and c) personal perception of cleanliness (Shove, 2003 a). At the most basic level, cleanliness is concerned with personal hygiene and protecting self from illness. However, the need for hygiene and protection of self is complex and multi-layered. Cultural rules and personal perception towards hygiene are interlaced in everyday practices. The fear of contracting disease and protecting health is one of the foremost concerns for cleanliness and hygiene. However, cues for cleanliness can be both culturally and personally driven. What may be perceived as unclean in one culture may be acceptable in another culture, while cultural rules regarding hygiene need to be practiced and reinforced to keep currency. For instance keeping shoes on inside of the house can be perceived unclean in Japanese culture while it is acceptable in some New Zealand homes.

Shove (2003a) explains that what is clean or hygienic to health is subjective. For example, laundering can present differences in personal perception or preferences as to frequency of washing clothes. Similarly hygiene and safety of food also present issues around variable perceptions. The best-before date on food is an example that illustrates personal differences in the ways of interpreting this information. These personal differences in perception may be due to Shove's argument that it is difficult to observe objectively what is safe. "Parasitic micro-organisms are not necessarily associated with dirt or smell, and things that look clean might yet prove dangerous. Equally filth can be harmless" (Shove 2003a, p87). Cleanliness therefore comes at the mercy of individual judgement. One set of standards could differ significantly from another. For these reasons, cleanliness is a complex area for analysis.

2.6.2.1 DESIGN RESONANCE

CLEANLINESS AND PRODUCTS

Cleanliness is an area of significant consideration for design for sustainability for reason being, providing for cleanliness can lead to a wide range of environmental impact. Perception and cultural expectations for

cleanliness may be central to behaviour around food waste while wide range of commodities that help ensure cleanliness also contribute to negative environmental impact. Consumers perception of hygiene can directly influence food disposal, while a large array of cleaning products are on the market to address this need, such as chemical detergents, can harm the environment. Further, with relevance to design, products and interface can become a key to providing the perception of cleanliness. For instance, heavy duty wash cycle may provide the perception of clothes being cleaner than after a short wash cycle, regardless of the actual result. Therefore the perception of cleanliness can be influenced by products and their functionality.

These issues suggest that assessing nuances surrounding the meanings of cleanliness may be vital to design for sustainability. A detailed understanding of the perceptions and cultural expectations for cleanliness may provide cues to shifting expectations of cleanliness and to design ways for providing cleanliness in more sustainable ways.

HUMAN CENTRED DESIGN STRATEGY AND CLEANLINESS

Cleanliness and perception may be an area that could be researched through human centred design observation strategies. Discrete observations and informal interviews may unveil finer details of perceptions of cleanliness that govern user behaviour. However, this poses a challenge, as gaining understanding of the nuances in culturally and personally embedded rules surrounding cleanliness may be difficult. Norms and rituals in everyday life may be unconscious reflections of rules surrounding cleanliness. These culturally embedded rituals and habits can be hard to locate through observations and interviews. This raises a possible limitation of a human centred design framework that supports the nature of design practice that require a rapid understanding of these sorts of information. Therefore, this is an area of consideration for the design phase of this research.

2.6.3 CONVENIENCE

The term convenience in Shove's text is defined with two nuances: the "modern" and the "hyper-modern". These definitions represent a shift in the associated meanings behind the word "convenience", with relating shifts in norms of everyday activities and expectations.

MODERN DEFINITION OF CONVENIENCE

The modern definition of convenience refers to reduction of time taken to achieve a goal. For example, domestic appliances are convenient products in that the appliances reduce time to carry out domestic tasks. Washing machines, for instance, reduce the time one attends to washing the clothes. Therefore it is a convenient product in a modern sense.

HYPER MODERN DEFINITION OF CONVENIENCE

The hypermodern definition of convenience explores the area of shifting time as part of organising daily schedules. Shove uses qualitative data from Sutherton's study as an example of endeavours to shift time: "We keep Sundays free as like our quality time but it does make Saturdays a bit hectic, like we try and get everything done so that Sunday is free so we can spend proper time together (Sutherton, 2003, p.13 cited in Shove, 2003).

The demand and provision for convenience is often met through resource consuming products and services to aid the need to juggle activities and shift or set aside time. Therefore, this is a significant area of concern for sustainability. For instance, a freezer allows storage and a shift in time. Meals made in advance at a more "convenient" or suitable time can be frozen and stored. The act of freezing meals in essence stores both the meal and time for a future when time is pressed (Shove 2003a).

CONVENIENCE AND CONTROL

The provision for convenience is a means to provide control for those with busy schedules. As Shove (2003a) states; "The value of speed and of instant response is sometimes relevant but the more important

issue is usually that of control. In allowing users to “store” time, defer activity or manage and minimise interruption, tools of this kind enhance capacity for autonomous organisation” (p172). A need for control in the organisation of everyday life is one of the important drivers for convenience. Therefore, Shove’s (2003a) analyses of convenience uncover fine nuances of expectations of everyday norms and how these expectations are met through daily schedules.

2.6.3.1 CONVENIENCE AND DESIGN

Areas of interest for design with respect to convenience are two fold. The agile nature of users adapting behaviour to artefacts in order to gain convenience is significant, and convenience is an important part of everyday life to meet the demand of expectations. The ways that users seemingly adjust their behaviour or alter existing products for more convenience are discussed in the book, *Thoughtless Acts* (Fulton Suri, 2005) as useful tool to gain insights into how users interact with products (Ingram et al., 2007). Cooking artefacts, such as a pressure cookers and slow cookers, demonstrate users’ capability to adapt to products so that convenience is achieved. Pressure cookers support the modern definition of ‘convenience’ by reducing the cooking time, allowing the user to save time on cooking process. In contrast, slow cookers reflect the hypermodern definition of convenience. Food is cooked over a longer period, asking the users to “shift time” by preparing a meal in advance to cook while being out of home (Carrigan & Szmigin, 2006). A provision for scheduling and time management that influence user behaviour are embedded issues surrounding these products.



Figure 2.4 Shove’s Comfort Cleanliness and Convenience (2003a)

What is interesting about these products in relation to convenience and design is the way users adjust their behaviour to each product to manage busy schedules. Slow cookers are by no means convenient when users have little time, but users adapt behaviour to the capability of the products to realise convenience. This suggests that convenience may be a driver towards altering user behaviour. Accounting for convenience as a foremost concern for design for sustainability may result in outcomes that are not only relevant to users, but also assist users to adapt behaviour to an ideal situation. However, products that prioritise convenience can lead to a negative impact on sustainability. Shove (2003b) uses frozen meals as an

example with this product the consumer has greater flexibility and control in the way time is use. On the other hand, catering for flexibility in this way is resource intensive, with consideration to the life cycle of these food products. Therefore, ways of catering for convenience with less impact on sustainability is an important consideration for research.

2.6.4 SHOVE'S 3CS IN A WIDER SUSTAINABILITY CONTEXT

The seemingly simple concept of Shove's 3Cs carries the extended nuances and details of everyday life. Figure 2.4 displays the broad meanings connected to each of the 3Cs. For design research, the 3Cs may act as brokers to help gain finer understandings around rituals, routines and habits that govern norms of everyday life and how social norms shift over time. The importance of understanding rituals, routines and habits of user behaviour to inform design for sustainable behaviour is evident in the study by Bhamra et al. (2011). This prompts two research questions: Are Shove's 3Cs applicable to design?: And, although the 3Cs were discussed in the context of energy management, could they extend to a wider sustainability issues? The applicability of the 3Cs to design is supported by Clune (2010), who suggests that understanding the demands for the 3Cs may be useful in finding barriers to more sustainable behaviour. Shove's 3Cs and a social practice approach may be useful tool to gain nuanced understandings of users of products and systems (Ingram et. al. 2007). In addition, extending the application of Shove's 3Cs to address wider sustainability issues may uncover rich insights that are useful to both an examination of the approach and its relevance to design. For the purpose of this research, Shove's 3Cs will be investigated in the area of food waste issues, as discussed in section 1.2. This is supported by a recent sociological study that uncovered rich nuances around domestic food waste. Evans (2012) used social practice theory to "explore how and why food that is purchased for consumption comes to be wasted" (Evans, 2012, p52). The findings from this study contributed to identifying disparate elements in the dynamics of everyday norms and routines against the temporality of food. The concluding arguments suggested that analysing domestic food waste with a sociological approach may indeed enrich the design process. However, to the best of my understanding,

to date, there has been little application of social practice theories to design interventions for food waste. Gaining an understanding of how everyday norms and rituals shift over time for food waste may contribute to design interventions that shift everyday norms to ones that are more sustainable.

2.7 SUMMARY

This chapter examined broad areas of research relating to design for sustainable behaviour. Section 2.2.2 identified that taking a pluralistic approach will be key to design interventions for sustainable behaviour. Therefore, the four broad approaches discussed in this chapter; sustainability design frameworks, (section 2.1), attitude behaviour relations (section 2.2), product-led interventions (section 2.3), and, social practice approach (section 2.4), including Shove's 3Cs (section 2.5) will be applied as required throughout this research. However, this research will focus in particular on Shove's 3Cs and their applicability to design for sustainability in the context of post-consumer food waste. Accordingly, the next chapter will outline the research design. Recent studies in design-led research will be explored to identify suitable steps to navigate this research.

CHAPTER THREE: RESEARCH DESIGN

3.0 RESEARCH DESIGN

This chapter outlines various design research approaches and methodologies that inform the research process. In particular, the design-led research method, design thinking and interdisciplinary approaches are the underlying strategies that are used to examine the research questions.

3.1 DESIGN-LED RESEARCH

Design-led research methodologies utilise a design process as a tool for research enquiry. In this research, design process, strategies and analysis will be applied as a research methodology to address the research questions (Burdick, 2003). More specifically, the human centred design process will be applied to guide the stages of this research enquiry to explore the applicability of Shove's 3Cs and other design for sustainability frameworks to the design process (Brown, 2008). Human centred design places foremost importance on the understanding of end users and considers ethnography as a valuable tool to observe subtle behaviours and interactions between users, artefacts and systems (Fulton Suri, 2005). Employing ethnographic analysis when designing artefacts and systems may lead to designed outcomes that can seamlessly be integrated into users' reality for the purpose intended (Brown, 2008). Therefore, the human centred design process is considered to be a suitable strategy to address the applicability of Shove's sociologically-driven 3Cs.

3.2 DESIGN THINKING

In recent years, there has been increasing interest in articulating the design process. One of the more contemporary and widely respected approaches of design is design thinking. Design thinking proposes that the design is a non-linear synthesis process, where design concepts "bridge" the two spectrums of a) framing a design problem; and b) offering a solution for a problem (Cross, 2006). Brown (2008) supports the position that design is not a step-by-step process, but rather: "The design process is best described metaphorically as a system of spaces rather than a predefined series of orderly steps" (p4). This means that design requires agility to navigate between, and through, the spaces of the design process: inspiration, ideation and implementation.

3.3 INTERDISCIPLINARY APPROACH

Design thinking requires sense making. Buchanan's (1992) well-recognised analysis of Rittel's wicked problem is relevant in two ways to this research. Firstly, design problems are identified as a "class of social system problems" (Rittel, cited in Buchanan, 1992, p.15). This suggests a shift of the designer's role from previous styling and form-giving practices toward embarking on a wider scope for design problems, context, and larger social issues. The wicked problem presented in these design contexts must be made sense of in order to offer a solution to the wicked problem (Buchanan, 1992). Design for sustainable behaviour may be presented as a wicked problem, which is a complex social and technological problem.

Secondly, an interdisciplinary approach is essential to address wicked problems. Buchanan (1992) argues, that

"Design problems are indeterminate and "wicked" because design has no special subject matter of its own apart from what design conceives it to be. The subject matter of design is potentially universal in scope because Design Thinking may be applied to any area of human experience" (p16).

Therefore design processes require an interdisciplinary approach in order to make sense of contexts that may vary according to each design practice. Design thinking and wicked problems require enquiry into interdisciplinary domains and an understanding of a wide spectrum of disciplines, including behavioural psychology and sustainability, as well as design process.

3.4 REFLECTIVE PRACTICE

Reflective enquiry will be carried out throughout this design-led research to inform the design thinking and ideation processes, and to evaluate the applicability of design for sustainability theories to this research project. Friedman (2003) argue that it is "Only explicit articulation that allows us to test, consider or reflect on the theories we develop" (p520). Other than a handful of studies which evaluate design processes and strategies (for example, Cross, 2006; Kolko, 2010; Jelsma & Knot, 2002; Lilley et al., 2006), a large number

of design research studies discuss frameworks and approaches as conceptual propositions. The need for further research to reflect on design practice is also expressed by Clune (2010) : “The general lack of critical reflection in current industrial design literature makes it difficult to learn from others’ mistakes and build on their successes, and restricts the intellectual growth of the discipline” (p73). Further, recording the design process through documentation of case studies may be a useful tool to enhance design education (Breslin & Buchanan, 2007).

In the scope of this research, focus will be given to the unfolding of a design process in order to identify theories, strategies and approaches that help inform design for sustainable behaviour. For this reason, this design research will not endeavour to implement a design concept, but rather prioritise evaluation of the design process. While acknowledging the non-linear approach to a design process, figure 3.1 outline design process, which will govern this design-led research.

Figure 3.1 Outline of research process

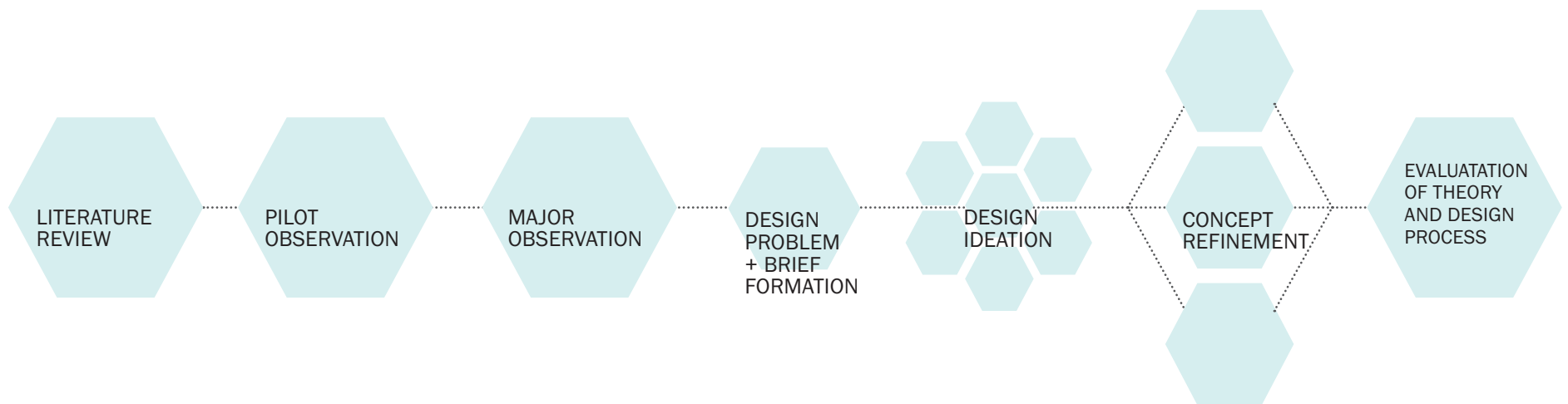

CHAPTER FOUR: PILOT OBSERVATION

4.0 PILOT OBSERVATION

Pilot observations were carried out to examine the relevance of Shove's 3Cs to the food waste landscape. Two institutional sites were observed and the methods used for these observations were assessed for their suitability for the major observation.

4.1 SITES OF PILOT OBSERVATION

The two sites for observation were a student hall of residence catering service, and a staff room at a tertiary institution. These sites were selected for the social context of the institutions. It was assumed that observation of these sites would be effective in gaining insights into how various individuals respond to food waste systems provided in these environments. At the time of the observation, the two institutions displayed keen interest in continuing to improve food waste separation systems at their respective sites. The food waste systems implemented at the two sites offered rich areas of focus for this observation.

4.2 METHODOLOGY

The pilot observation used human centred design methods and prompts from Ideo (2003) cards to gain insights into the everyday practices surrounding food waste disposal. Ideo method cards offer a set of prompts for design observation and ideation. The aim of this observation was to capture usual behaviour with the result that methods used needed to be discrete. Consequently, from the set of Ideo cards, Fly On The Wall, Rapid Ethnography, and Still Photo Survey (Ideo, 2003) methods were selected and carried out.

Rapid Ethnography is a method in which the designers immerse themselves in the site of the design project to gain first-hand insights, nuances and rituals around an activity. This method involves observing and participating the relevant activities. Rapid Ethnography was used at both observation sites, during lunch at the student hall of residence and tertiary institution staff room.

Fly On The Wall method was carried out during and alongside Rapid Ethnography. This method observes actions of people within the activity without interference, to gain an understanding of their behaviour. The aim of this method was to observe different interpretations and ways of interacting with food waste.

Lastly, during Still Photo Survey methodology, a planned photo survey to capture specific activities and objects was carried out. For the tertiary institution staff room, the focus was given to food waste separation bins. Similarly in the student hall of residence, still photos were taken of food preparation and disposal, and the collection area where residents return their finished plates and uneaten food.

This research required the observation of everyday behaviour of users in the design context. The participants involved in the interviews and the managers of the observation sites were asked to sign consent forms prior to the interviews and observations (for consent form see appendix 1). Some observations prompted conversations with participants on the observation site. On these occasions, the participants were also asked to approve the consent prior to recording these conversations. The consent form explained that the participation was entirely voluntary, and that they were free to withdraw from the project at anytime. This research also made every attempt to preserve the anonymity of the participants.

4.3 RESULTS AND DISCUSSION

The pilot study methodology led to a number of key findings that illustrate the relationship between food waste and Shove's 3Cs. Further, relevance to other theoretical frameworks was found. For the purpose of assessing the suitability of Shove's 3Cs to food waste, the observation findings will be categorised under theoretical viewpoints.

4.3.1 DISPOSABLE FOOD PACKAGING AND SHOVE'S 3CS

The importance of hygiene and packaging in student hall of residence during lunch activity was recognised through their recent introduction of single serve breakfast spread packaging. Previously, spreads such as jam were served from large jars into small bowls. However, unused excess spread at the end of each catering session was problematic for waste and hygiene. If the spread was returned to the bulk jars to prevent waste, it could potentially contaminate the entire jar. To avoid this issue, the spreads are now provided in single portion packages (Figure 4.1). The staff and residents were aware that this would produce more plastic packaging waste. However, the result was a more hygienic breakfast spread service for a large number of students where possible contamination and large amounts of waste could be prevented.

Figure 4.1 Single serve disposable packaging

A site allocated to spread condiments on toast. Single serve spreads are used and disposed of at this site.



4.3.1.1 DISCUSSION

Shove's 3Cs is embodied in single serve food packaging. Single serve packaging provides convenience, hygiene and protection of self. This cleanliness leads to comfort in a way that provides peace of mind. Further, Shove (2003) argued that providing for the 3Cs accelerates the rate of consumption. The 3Cs may be one of the catalysts for the growing variety of food that is packaged as disposable single serve item. Although this student hall of residence has adopted this way of using spreads recently, single serve packaging is part of the larger landscape of food distribution. Other examples include single portion chocolate bars, yoghurt containers, and crackers.

In the case of this hall of residence, the implication for the environmental impact of the change to single portion spreads cannot be assumed without a life cycle analysis. When taking into consideration the potential for food that is wasted from contamination single portion packaging may be more favourable. Similarly, some materials involved in single portion packaging may be equivalent material content to related bulk food packaging. For instance, one kilogramme of yoghurt in a heavy duty plastic container may be manufactured with a similar amount of plastic as six singly packaged yoghurt in a lighter plastic.

Shove argues that the 3Cs can act as catalysts to increase expectations and demand into a “ratchet affect” (Shove, 2005 p195). As food packaging meets the desire to address the 3Cs, greater expectations are raised to constantly improve ways food is packaged. This continuous shift in expectations potentially may lead to a larger environmental impact. The ramifications for single portion packaging extend to parameters beyond this student hall of residence and present a future scope for research

Figure 4.2 Bokashi Composting Process

4.3.2 SHOVE’S 3CS AND ATTITUDE BEHAVIOUR RELATIONS

The applicability of shove’s cleanliness and convenience in conjunction with the classic attitude behaviour relations (Ajzen & Fishbein, 1977) was highlighted in observation of the composting systems at the tertiary institution staff room.

The institution staff room uses a Bokashi composting system. This system entails an anaerobic fermentation process to decompose organic matter. After fermentation, the organic matter is buried in earth and turns to soil. This system relies on two user groups to ensure the correct process is followed. The first user group is those who dispose of food waste into the bin. The second user group is the “Bokashi Champions” who are responsible for the maintenance of the bins. The Bokashi champions empty the organic food waste from the interim bins into the Bokashi bins once a day and apply the active micro organisms. When the Bokashi bin is full, the champions monitor the fermentation process, then bury the fermented Bokashi composting matter into the earth.

Bokashi composting provides convenience for the first user group, because of Bokashi’s capacity to compost materials such as meat and cooked food. Meat and cooked food are unsuitable for conventional composting processes but are an unavoidable part of food waste. The Bokashi composting system, therefore, is convenient in the sense that organic food waste needs no further separation and does not require detailed understanding of composting. For the Bokashi champions, however, this system requires a commitment of effort.



1. Food Scrap bin is provided to separate from other waste.

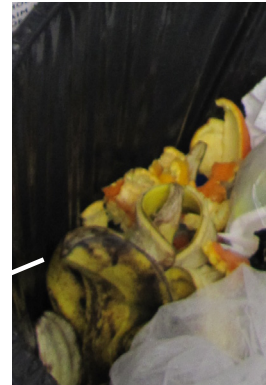

2. Food waste is also often disposed in the general waste bin.



3. A white plastic container is placed at the site to dispose of tea bags.



4. Once a day the staff room cleaner/ Bokashi Champion empties the food scrap bins in (Steps 1 & 2) into a Bokashi bin. The active agent is added to the bin and the lid is sealed for the anaerobic fermentation process.



5. When the bin is full, it is left to ferment for several weeks. During this time the staff continue the process by using a second bucket. After the fermentation is complete the organic food waste to is dug into a garden to decompose.

Issues surrounding cleanliness were obvious in the Bokashi composting system. Figure 4.2 step 2 indicates food scraps that are disposed of in the general waste. Several users of this system said they did not want to touch the Bokashi bins to open them. One user said: “You just don’t want to touch the lid to open it so sometimes it’s just easier to throw it into the general bin that’s already open.” Refusal to handle the food scrap bin leads to behaviour that breaks down the system.

Figure 4.2 Step 4 also showed the conflict between the need for cleanliness with the nature of the Bokashi composting method. While many participants were supportive of this initiative to compost food waste, the issue of cleanliness discouraged many people from using this system in a number of ways. Some participants said that the sight of a large amount of other people’s waste in the Bokashi composting bin made them feel ill. I found this to be personally the case during the *Rapid Ethnography* method when I was given a bucket of Bokashi waste from the staff room to process. In particular, these comments resonated when I emptied the Bokashi bins to bury in the garden. The visual cues and smells of organic food waste challenged my positive attitude towards composting.

4.3.2.1 DISCUSSION OF OBSERVATIONS

A conflicting link between Shove’s 3Cs and attitude-behaviour relations in relation to food waste and hygiene was highlighted. Dealing with food waste challenges the perceptions of cleanliness, hygiene and protection of health of self (Shove 2003a). Therefore, a positive attitude towards organic disposal is helpful, particularly to recruit Bokashi Champions for the smooth running of the system. However, pro-environmental attitudes could conflict with the need for cleanliness. The lack of provision for cleanliness can override positive attitudes towards composting food waste from the staff room.

Furthermore, this observation outlined the importance of designing for various stakeholders. In this situation, the system is convenient for those who dispose of organic waste, but less so for the Bokashi Champion user group. This analysis suggests that an ideal composting system is one that is clean and convenient for multiple user groups.

4.3.3 SYSTEM-BASED NORMS

The student hall of residence catering demonstrated a simple and effective system for organic food waste. The organic food waste from preparation and clean up of catering was collected in plastic buckets, then stored in a cool room for collection. A local farmer collects the organic waste to feed pigs. It is important to note here that national biosecurity has strict restrictions on feeding meat and food waste to commercially grown pigs, making it difficult for wider local industries to dispose of food waste in this way.

Figure 4.3 Pig Bin at use during food preparation



At this student hall of residence, however, this system was embedded in the catering system. Figure 4.3 catering staff member said: “I just grab the bucket when I’m preparing to put the scraps in. The guy (pig farmer) comes and collects the buckets couple of times a week so it’s really easy. And it’s good that we reduce waste.” The attitude of the catering staff to reduction of food waste reflects commitment to a system to reduce waste. These included serving left-over food from an evening meal for lunch the following day and implementing a pig bin. The pig bin was located at the site for returning plates. A production line with a series of visual prompts navigated residents to return utensils and dispose of organic waste in a dedicated systemic way.

The production line displayed a clear division of responsibilities between the residents and the catering staff (see Figure 4.4) The residents’ responsibility was to avoid holding up the production line while disposing of food in the pig bin and returning utensils and plates. At the end of the lunch service, it was then the catering staff’s responsibility to wipe down and make the kitchen into a hygienic space.



1. Resident scrapes left over food into pig bin chute



2. Pig bin chute

Figure 4.4 A site for returning plates and disposing of uneaten food



3. System chain for returning plates during lunch service



4. The same site is cleaned after the lunch service

4.3.3.1 DISCUSSION

At this site, practices and norms around food waste were largely driven by the systems. The production line within the catering system for both receiving food and returning plates provides prompts for intended behaviour. This study underpins the significant role that well designed systems play to establish routines and norms around food waste disposal.

Elements of convenience and social comfort play significant roles in this system-based norm. It is the objective of the production line to carry out the catering process in the most efficient and convenient way possible. The goal of convenience in this case is to reduce time for serving food to complete services in a given time period. Convenience and efficiency are driving factors of this system.

On the other hand, production lines are highly social activities where elements of social comfort are present. The intended behaviour is visually enacted by those who are in the front of the queue and following each other's behaviour is an important aspect of maintaining and embedding norms. This was personally the case when I participated in the lunch service as a part of Rapid Ethnography method. I had no prior knowledge or instruction of how to behave in the production line. However, the production line and the residents were affective in prompting behaviours, such as disposing of uneaten food at the 'pig bin' or leaving cups in a specific location.

The production line in this system reflects Shove's convenience and social comfort. It is the objective of the production line in the catering service to serve food and have utensils returned in the most convenient and efficient way possible. The issue of social comfort or what could be described as comfort in numbers and following each other's behaviour play important roles in creating system norms for this site of food waste disposal. The users of the catering system are following the behaviour of others in the same system as a cue for how they are to comply with the system chain.

In terms of cleanliness, however, the responsibility for cleaning and over all tidiness was appointed to kitchen staff. Figure 4.4 shows that around the "pig chute" was an area that was less clean at the time of returning plates and utensils. Here the importance is placed on the speed and efficiency of students bringing back the plates, and as a result, cleaning is carried out by the catering staff after the plates have been returned. This indicates that within a system and in public spaces where responsibility of cleaning is assigned to staff, each individual may play a less active part in ensuring cleanliness.

In a system-based norm, convenience and reduction of time are driving objectives for production lines and aspects of social comfort become an integral part of prompting the ideal behaviour. In addition, when cleaning was assigned to catering staff, the responsibility of cleanliness shifted from the individuals to the staff. Therefore, in the system-based norm, cleanliness is highly controlled by the staff involved in the system production line.

4.4 SUMMARY

4.4.1 SHOVE'S 3CS AND FOOD WASTE

This pilot study was instrumental in indicating that Shove's 3Cs can indeed be extended to everyday practice of food waste. Shove's 3Cs was central to the need for single-serve disposable food packaging, while the need for cleanliness and comfort could work against positive attitudes and behaviour towards food waste composting. In contrast the elements of cleanliness made little contribution to driving the norms of the catering service. Instead, the systems embedded in the service was a significant factor. In addition, convenience was a driving motivation for production lines within the system to efficiently serve a large number of residents. Elements of social comfort were also demonstrated in the production line where following each other's behaviour was an important aspect of smooth running of the service. This analysis indicated that Shove's 3Cs can be extended from energy consumption to context of food waste.

4.4.2 SHOVE'S 3CS AND THE OBSERVATION STRATEGIES

For the pilot observation, Shove's 3Cs as a theoretical framework, were instrumental in providing a clear focus. Both of the observation areas, the tertiary institution and student hall of residence catering service displayed complex situations involving intricate systems and boundaries between user groups. Shove's 3Cs helped narrow the focus of the observation to user needs and perceptions in relation to the 3Cs. This focus

helped explain details within various situations. Therefore, Shove's 3Cs was used as an integral part of finding insights in the major observation of this study.

The three human centred design methods, Still Photo Survey, Fly on the Wall and Rapid Ethnography, were effective in capturing users' interactions surrounding food waste. In particular, Rapid Ethnography, allowed immersion in the site of the observation to provide rich context and details of the site. For both of the sites, having to understand intricate systems and how to interact with food waste disposal was useful. In addition, the conversations and informal interviews with regular users and staff of the space lead to useful insights.

In contrast, the Fly on the Wall and Still Photo Survey methods played important roles in uncovering the unconscious imprint of everyday behaviour. For example, a banana skin found in the general bin next to the composting bin was clear evidence that, in this instance, the ideal behaviour was not followed. These methods were valuable in showing evidence that, at times, contrasted with personal interpretations gained from the Rapid Ethnography. For these reasons, these three human centred design methods will also be used throughout the following major observation.

CHAPTER FIVE: MAJOR OBSERVATION

5.0 INTRODUCTION

To further investigate how Shove's 3Cs can contribute to design interventions for food waste a local farmers' market was selected as a site for design intervention. An observation of this site was carried out to gain an understanding of practices and systems used during the farmers' market food waste disposal. The insights gained from this observation were analysed to form a design brief for the subsequent design ideation phases of this project. Where possible, analysis of the findings was sought for relevance to Shove's 3Cs and other sustainability frameworks discussed in the literature review.

5.1 SITE OF OBSERVATION AND DESIGN INTERVENTION

For a number of reasons, the farmers' market was recognised as a suitable site for a major observation to investigate how Shove's 3Cs could inform design process to assist with food waste disposal. The social context of the farmers' market provides a rich observation that spans across various stakeholders, their behaviours and the disposal system. The disposal system, being a closed loop waste stream, allows for controlled data in tracking waste. In addition, the farmers' market was carrying out a waste minimisation initiative, and was interested in a perspective from my project. This initiative provided a breadth of insights for this research. For further study, the outcome from this project may be scalable to a larger setting for future research.

5.1.1 FARMERS' MARKET AND SHOVE'S 3CS

In a similar way to the site of pilot studies, the farmers' market is a social space where waste disposal is governed by an array of disparate elements of practices. These elements include the motivation of a committee group and vendors as well as individual attitudes and behaviours of visitors to the site. While the pilot observation demonstrated that Shove's 3Cs can be extended to the realm of food waste disposal, Shove's 3Cs may also be a significant tool to make sense of disparate elements in the practice of everyday norms at the farmers' market.

5.1.2 CITY COUNCIL WASTE MINIMISATION INITIATIVE

At the time of the observation, the farmers' market committee and the city council waste management group were undergoing a waste minimisation initiative. The initiative group was accommodating to my research to observe the practices of food waste disposal and the alterations they were implementing through their minimisation initiative. Observation of the practice of waste disposal and waste minimisation strategies offered a breadth of insights for further research. Figure 5.1 displays the farmers' market stakeholders and figure 5.2 outlines the time line of the waste minimisation initiative of the farmers' market in relation to this research.

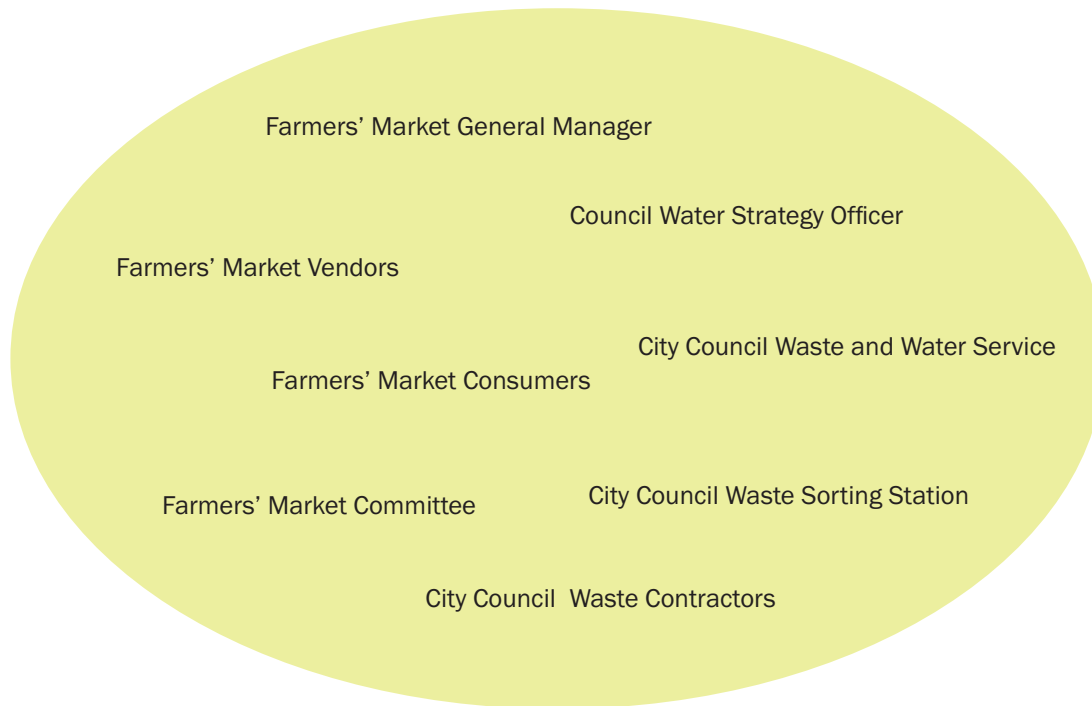

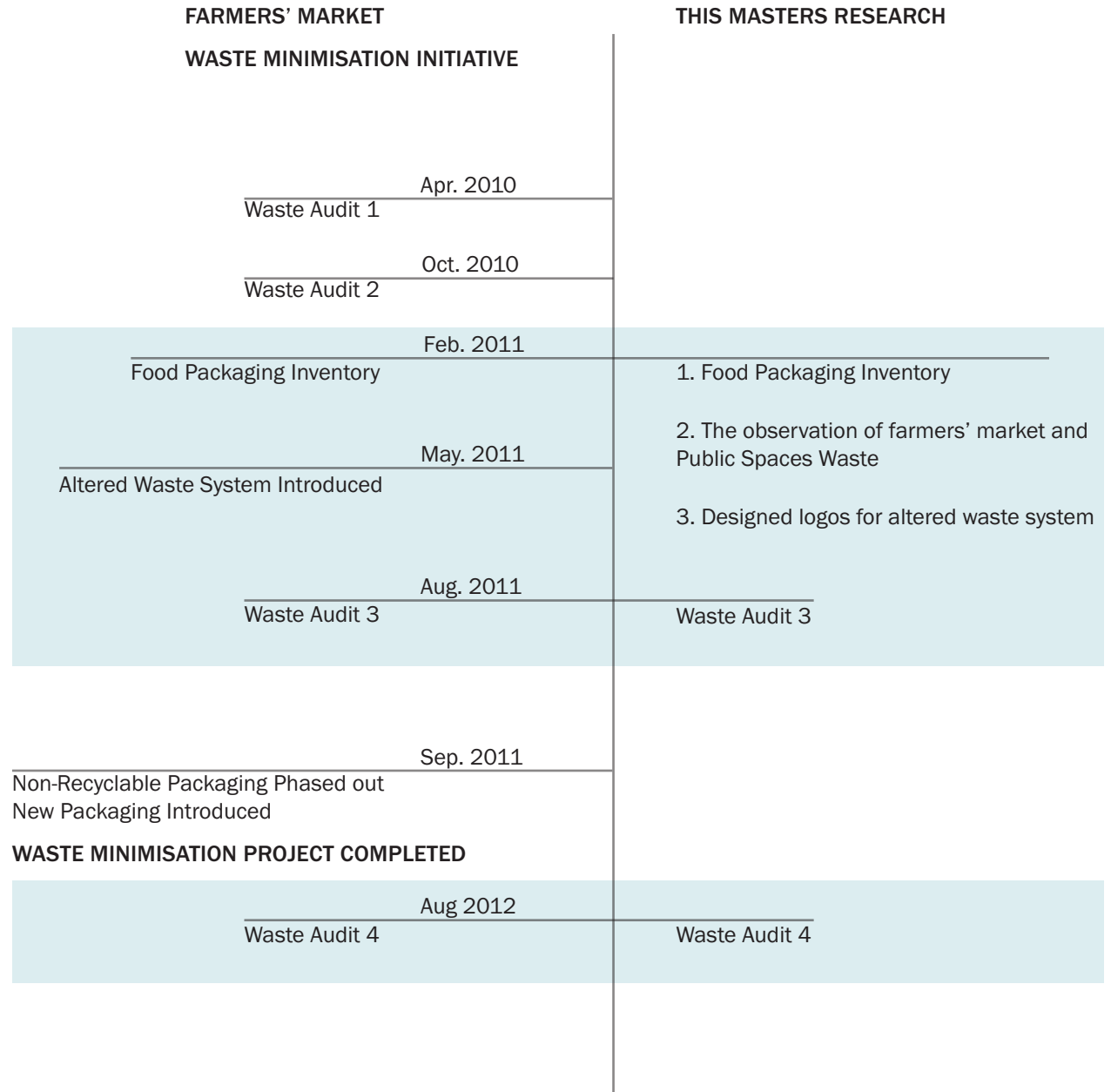

Figure 5.1 Stakeholders of the farmers' market waste minimisation initiative

Figure 5.2 Timeline

Timeline of farmers' market waste minimisation Initiative and this research

 Period during which, the farmers' market initiative and this research were carried out in conjunction



5.1.3 CLOSED LOOP WASTE SYSTEM

The closed loop waste stream is another area of the farmers' market that is suitable for this research. The waste disposed of at the farmers' market can be directly tracked back to the source of the waste on site from the vendors. This gives this research greater control in the design of interventions to minimise waste. Table 5.3 illustrates the farmers' market waste categorised into three types by the waste minimisation initiative.

Table 5.3 Waste Categorisation

	TYPES OF WASTE	SITE OF DISPOSAL	RESPONSIBLE FOR DISPOSAL
PUBLIC SPACES WASTE	Food Consumed at the Market	Centralised Farmers' Market Waste Separation bins	Farmers' Market and City Council
VENDORS WASTE	Vendors' Waste Related to Trading	Off site from Farmers' Market	Vendors
TAKE-AWAY WASTE	Packaging waste of products taken off site eg. Vegetables, Fruits, Meats, Cheese etc	Off site from Farmers' Market	Visitors

These categories illustrate the complex scope of further investigation for waste minimisation of all areas of waste disposal and separations. For the purpose of this research, however, the waste minimisation is focused on the Public Spaces Waste in alignment with the farmers' market waste minimisation initiative. The public spaces waste is limited to the waste disposed of on site at the farmers' market that is largely food products consumed on the site. This closed loop waste stream allows this waste minimisation initiative to be one that is manageable for a short-term project.

5.1.4 SCALABILITY

The design intervention for a specific closed loop site such as the farmers' market offers scope for being scalable. Interventions that are effective on this site may be transferred to wider scope for sites with public food vendors and consumption.

5.2 METHODOLOGY

The major observation applied the three human centred design observation methods, Fly on the Wall, Still Photo Survey and Rapid Ethnography which proved useful in the pilot observation. In addition, waste audit for the market was carried out alongside the internal food packaging audit.

5.2.1 FLY ON THE WALL AND STILL PHOTO SURVEY

Fly on the Wall and Still Photo Survey methods were widely used over twelve weeks at the farmers' market to document visitors' interactions with the centralised waste separation bins. The key objective of the Fly on the Wall and Still Photo Survey observations was to capture how users interpret and interact with the current bins. Rather than interviewing the visitors about waste separation, the Still Photo Survey of the inside of the bin captured the actual ways visitors were separating waste. This observation indicated both the current practice of visitors as well as the effectiveness of the separation bins. Rapid Ethnography was also carried out as I participated in the market as a visitor and a consumer. During Rapid Ethnography, some informal interviews were carried out with the farmers' market visitors and vendors.

5.2.2 WASTE AUDIT

A waste audit was carried out to evaluate the amount and the types of food waste disposed of at the market. This audit is carried out annually and used by the farmers' market and the city council to ensure reduction of waste over time. The data is collected by weight and the types of waste.

5.2.3 PACKAGING AUDIT

A packaging audit identifies the current packaging that is given out to customers. For food that is consumed on site at the market, the waste is a direct reflection of the food packaging selected by the vendors. Therefore, a packaging audit of the farmers' market was carried out to identify areas for improvement for the waste stream.

5.2.4 INFORMAL INTERVIEWS

During the observation I also met with the farmers' market general manager and the city council waste strategic officer to find out their waste minimisation strategies. The interview revealed some insights into their experience, initiatives and strategy partners. I also designed some waste disposal logos as a result of some conversations from these meetings.

5.2.5 OBSERVATION ANALYSIS

These methodologies led to collecting wide and varied data. This data was analysed with consideration to Shove's 3Cs and other design for sustainability frameworks. The following section will discuss the results in categories of insights followed by discussion. These analyses of the observations were instrumental in creating a design brief for the subsequent design ideation section.

5.3 RESULTS AND DISCUSSION

5.3.1 WASTE AUDIT

A waste audit of public spaces waste was carried out to assess the actual types and quantity of waste generated for one day's farmers' market trading. This result is also instrumental in evaluating the on-going affect of the waste minimisation initiative.

This waste audit indicated a number of significant areas of interest.

1. The organic waste was the largest area of waste, which includes uneaten food, and paper-based food packaging.
2. Within the organic waste, disposable paper coffee cups made up the majority of the organic waste in weight.
3. Paper waste, including serviettes, paper bags and disposable coffee cups were disposed of across all waste separation bins.
4. Disposable paper coffee cups were often not separated from the plastic lids as intended by the system to recycle materials separately.
5. Small amounts of recyclable plastic and glass bottles were found, which directly relates to a limited trading of bottled drink at the market.
6. The vendors of the farmers' market are asked to be responsible for their own waste and are not permitted to dispose of waste from trading in the audited public spaces waste. However, the audit found a considerable amount of vendors' waste, such as hot chocolate powder containers.
7. Some of the vendors' waste showed no attempt at separation of waste. A mixture of waste, which may have accumulated during the trading, was thrown out in a plastic bag.

Figure 5.4 Waste Audit Process



1. Emptying waste disposal bags to sort waste



2. Sorting Waste

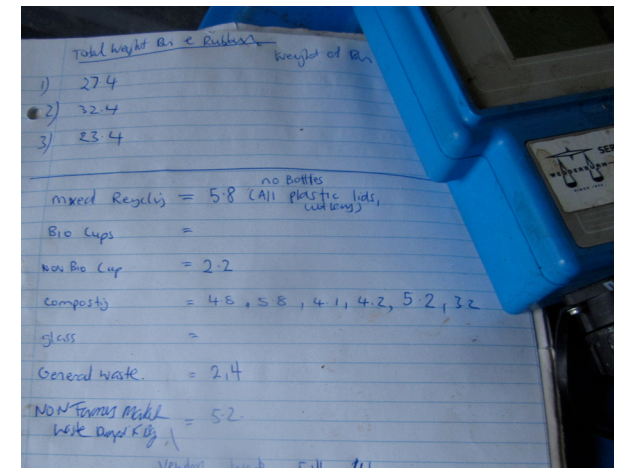

3. Weighing the waste after sorting

5.3.1.1 DISCUSSION

The waste audit was a useful tool to quantify the current waste disposed of at a given market.

1. The organic waste was the largest area of waste, which includes uneaten food and paper-based food packaging.

This is a favourable result for the waste minimisation initiative, as the objective was to reduce waste going to landfill. The organic waste was intended to be disposed of at a local worm farm facility with the anticipation that this facility would grow over time. However, at the time of the observation, not all organic waste was able to be composted due to the limitations of the facility. This may be a reflection of both the complexity of composting systems and being unsuccessful to locate a suitable industrial composting plant to process the large amount of organic waste.

It is important to recognise that the systems and science involved in industrial scale composting are areas where more research is needed. At the same time, this audit result displays an inconsistency between the ideal waste separation system and what is currently possible in the local area with respect to ways of dealing with various kinds of waste.

2. Within the organic waste, disposable paper coffee cups made up the majority of the organic waste in weight.

Designing ways to reduce the number of disposable cups used at the farmers' market would significantly change the landscape of waste. This issue will be considered further when forming the design brief.

3. Paper waste, including serviettes, paper bags and disposable coffee cups were disposed of across all waste separation bins.

The issue of disparity between actual behaviour and the intended waste separation system was also displayed through the Still Photo Survey. This will be further discussed in the following section.

4. Small amounts of plastic and glass bottles - directly related to limited trading in bottled drink at the market.

This result resonates with the food packaging audit findings and the direct correlation between food packaging provided to customers and disposed of. Providing food packaging with consideration to the environmental impact and the impact on the waste stream is an important issue for this project.

5. and 6. The vendors' waste with no separation found in the Public Spaces Waste.

These findings indicate a number of issues, including the vendors' interest in the waste minimisation initiative and their practices and related waste through a day of trading. The waste minimisation initiative may require further support of vendors to minimise waste from the farmers' market. On the other hand, this also provides an opportunity for the farmers' market to create ways that vendors can easily separate waste during their trade. Rather than continuing the practice where vendors combine all waste into plastic bags to dispose of elsewhere, this situation may be improved through a design intervention. However, taking into account the vendors' practice and their waste, this waste stream is no longer a closed loop. This adds further complexity to the waste minimisation initiative. Therefore, for the purpose of this research I will focus on designing an intervention towards improving the current closed loop system.

5.3.2 FOOD PACKAGING AUDIT

A food packaging audit was conducted to seek areas for improvement in packaging given out by vendors, which directly contribute to the public spaces waste. This audit identified three packaging items for improvement: polystyrene clam shell packaging, paper bags with wax coating, and disposable coffee cups with plastic lining. Both paper bags and disposable cups are composite materials that cannot be recycled in their current system.

Following this audit, the vendors responsible for this packaging were consulted to phase out the packaging to be replaced with biodegradable counterparts made of paper and biodegradable film. As a result, the non-recyclable packaging was phased out, with new packaging introduced in September 2011. Figure 5.5. illustrates the result of the packaging audit and displays vendors' packaging before the waste minimisation initiative.

5.3.2.1 DISCUSSION

The packaging audit method in Section 5.3.2 assisted the minimisation initiative towards a positive impact to the waste stream. Identifying and phasing out unfavourable food packaging from the waste stream was an effective strategy to minimise waste. The wider implications of the environmental impact from the changes to new packaging cannot be assumed without a thorough life cycle analysis. However, this food packaging audit and consequent changes resulted in reducing the amount of general waste for landfill.

This methodology reflects Thorpe's (2010) argument of choice editing, that enforcing rules for vendors at the farmers' market was an effective strategy to minimise waste, rather than to solely rely on individuals to carry out pro-environmental behaviour. The implication of choice editing is vast for design process. Gaining an understanding of current choice editing rationales performed at various levels, such as government policies and business and organisation rules inform a design brief. By knowing what the choice editing

Figure 5.5 Packaging Audit Process

Audit of Vendors Packaging at the farmers' market

COMPOSTABLE PACKAGING



Paper Coffee cups with biodegradable lining



Paper bags, plate and napkin



Organic waste

RECYCLABLE PACKAGING



Glass Bottle



Plastic cutlery and lids



Plastic cup

NON-RECYCLABLE PACKAGING



Polystyren Clam Shell
Replaced by paper alternatives



Wax coated paper bag
Replaced by paper alternatives

rules are, designs can meet the policies and rules. Providing a greater variety of options that are designed in compliance with policies and rules would further give customers choices and also shift the norm.

It must be mentioned here that the success of this packaging audit reflects the skilful management of the waste minimisation initiative group. Persuading various vendors of the farmers' market to alter operational practice and packaging required a positive buy-in from the vendors around waste minimisation. This indicates the importance of the human centred design process to consider the end users.

5.3.3 PRIOR KNOWLEDGE, ASSUMPTIONS AND WASTE SEPARATION

One of the major findings from the Still Photo Survey was that waste was often not separated according to the intended separation system. Figure 5.6 and Table 5.7 display the samples of waste separation and analysis. The major contributor to contamination in the waste bin were coffee cups, paper serviettes, paper plates and polystyrene clam shell packaging. The contamination is not simply a result of lack of interest in waste separation. Rather, contamination is due to complex layers of visitors' prior knowledge and experience that contributes to waste separation. This is especially the case for visitors who intend to separate waste, but their knowledge was not aligned with the waste separation system at the farmers' market. Informal interviews found that waste separation can be interpreted from multiple perspectives. For instance, paper waste was interpreted in multiple ways such as:

1. Paper is recyclable;
2. Paper is not compostable;
3. Paper should not be composted in large amounts, therefore farmers' market would not compost paper;
4. Disposable coffee cups are made with a plastic lining that is not biodegradable or compostable;
5. Paper used for food and personal care, such as wiping the mouth, should not be either recycled or composted; and
6. "I just use the general waste bin as a default when you do not understand the system, because you will probably get it wrong and you don't want to affect the recycling system."

Figure 5.6 Samples of Waste Separation

Still Photo Survey 18.02.2011 - 05.05.2011



A, C



A, C



A



A, C



A, C



A, C

Non-recyclable

- Intended for:
- Polystyren clam-shell containers
 - Plastic wrappers
 - And bags



A, C (Plastic bags currently not a part of city council recycle scheme)



A, C (Waste from external source to the market trading)



A, B, C

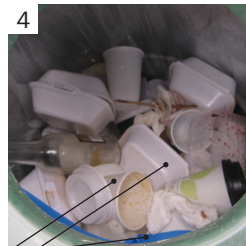

A, B, C

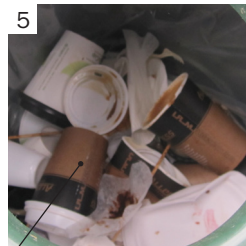

A, (eg. Coffee cup lid not separated from the cup)



A, B, C

Recyclable

- Intended for:
- Glass bottles
 - Plastic bottles
 - Plastic coffee cup lids
 - Plastic containers

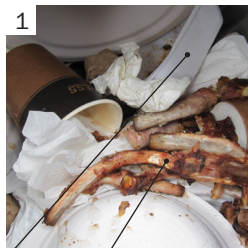

B
C (Bones can not be composted)



C



B



C (Plastic strapping: Vendors waste)



Compostable

- Intended for:
- Coffee cups
 - Paper waste
 - Organic waste

Contamination : A. Disposable coffee cup contamination
 B. Clam shell polystyren contamination
 C. Other contamination

Table 5.7 Analysis of Waste Separation

	Intended for:	Contaminated with:	Issues:	Alterations from waste minimisation scheme:
Non-Recyclable	<ul style="list-style-type: none"> • Polystyren clam-shell containers • Plastic wrappers • Plastic bags • Other non-recyclable waste 	<ul style="list-style-type: none"> • Coffee cups • Paper waste • Wooden skewers • Plastic coffee cup lids • Glass bottles 	<ol style="list-style-type: none"> 1. A large amount of polystyren clam-shell containers at present. 2. Used as a default bin when separation is confusing. 	<ul style="list-style-type: none"> • Polystyren clam-shell containers phased out. Replaced with paper clamshell containers.
Recyclable	<ul style="list-style-type: none"> • Glass bottles • Plastic bottles • Plastic containers 	<ul style="list-style-type: none"> • Coffee cups • Paper waste • Wooden skewers • Polystyren clam-shell containers • Plastic wrappers • Plastic bags 	<ol style="list-style-type: none"> 3. Coffee cup lids are not separated from cups. 4. Confusion with paper recycling. 	<ul style="list-style-type: none"> • A station is provided to prompt visitors to take lids off coffee cups and separate for disposal.
Compostable	<ul style="list-style-type: none"> • Coffee cups • Paper waste • Organic food waste • Wooden skewers 	<ul style="list-style-type: none"> • Coffee cups • Paper waste • Polystyren clam-shell containers • Plastic wrappers • Plastic bags 	<ol style="list-style-type: none"> 5. A large number of disposable coffee cup are present. 6. Some organic food waste can not be composted, eg. Meat and bones see image compostable 1. 	<ul style="list-style-type: none"> • A larger waste separation bin has been provided to cater for large amount of paper waste.

5.3.3.1 DISCUSSION

The waste separation at the farmers' market brings to light some disparities surrounding visitors' prior knowledge compared to the market organisation's assumptions. The visitors to the market have a wide range of preconceived understandings, assumptions and personal preferences. This observation shows that clear communication to guide visitors towards ideal waste separation is beneficial. However, the attraction of a wide range of visitors makes communication design challenging. Further, an analysis of current communication design may demonstrate ways of encouraging visitors to use the separation bins appropriately. In the same way, a reconsideration of waste separation bins in terms of ergonomics, visibility and interaction design would ensure an improvement in waste separation. For the purpose for this study, the focus is given to product-led sustainability frameworks and in shifting norms that rely less on communication and interaction design.

5.3.4 COMMUNICATION DESIGN FOR WASTE SEPARATION

The wording used for waste separation bins was one of the causes of confusion. To resolve this issue, and to align with a national waste separation scheme, the farmers' market launched new separation bins in May 2011. All three separation bins and the names were confusing to the visitors because of the multiple interpretations that could be derived from the words. The wordings and the logos were altered as shown in Figure 5.8

Figure 5.8 Changes made to waste separation signage

PREVIOUS SIGNAGE		RELAUNCHED IN MAY 2011
Rubbish - Non Recyclable	→	Non Recyclable
Mixed Plastic and All Cans	→	Glass and Cans
	↘	Mixed Plastic
Worm Farm	→	Food - Paper - Cardboard

5.3.4.1 DISCUSSION

Using the analysis of this observation, a proposal was made to introduce a paper separation bin for coffee cups and paper waste that made up the majority of the waste from the farmers' market. Another rationale for this proposal was that, by specifying materials, multiple interpretations could be eliminated. This is the case with glass waste. In the local context, the glass bottles collected for recycling are crushed to be used as material to build roads, although some people assume that bottles are recycled back to glass. This example demonstrates that making information available on how waste is treated is important. However, at the point of waste disposal, convenience, clear communication and speed at which the waste separation system is deciphered become key to a successful waste separation scheme. As a result, the previous 'worm farm' bin was altered to read 'Food - Paper - Card board - No Meat' to give clarity.

This observation also shows the role that national schemes play on influencing waste separation. The national scheme assumed that it would be favourable to have a unified language for all waste separation across the nation. This unified language could, in time, eliminate the confusion and personal interpretations. Therefore, defining language for food waste is a complex issue that requires much research with users prior to the understanding of waste. This will also require on-going education for the users.

Designing interventions towards a united language for food waste provides considerable scope for future research. However, for the purpose of this research, the importance of convenience and other means of clarity for waste separation will be investigated.

5.3.5 SOCIAL COMFORT AND FOLLOWING EACH OTHER

The attempt to separate waste in the "right way" was signalled by visitors by peering inside the bins for a visual cue for waste separation. This reinforced the assumption that a large number of visitors to the farmers' market are indeed interested in complying with the waste separation scheme. However, this also

meant that when waste was separated in an incorrect way, this was also used as a cue for successive waste disposal. In response, the farmers' market began sorting the bins periodically during the market to correct the wrongly separated waste to ensure consistency of cues for correct separation.

5.3.5.1 DISCUSSION

This behaviour resonates with Shove's (2003a) explanation surrounding social comfort and comfort in numbers. Visitors to the farmers' market take cues from each other to behave in socially appropriate ways and this extends to behaviours surrounding waste separation. In contrast Shove's argument for the need for cleanliness was not reflected in the visitors' behaviour. Particular visitors in the observation willingly peer through the waste bin for behavioural cues, although this may not be a preferred behaviour. This may indicate a need for boundaries within cleanliness where, for instance, seeing is acceptable, while touching may not be as acceptable. This poses a basis for on-going enquiry into the relationship between cleanliness and public waste.

5.3.6 RE-USE CUPS

A valuable insight was gained in a conversation with a regular visitor to the farmers' market on reusable coffee cups, who said:

“ I used to take reusable coffee cups to the market, but those people (coffee vendors) have a real system going. One person takes money and calls out the order and uses disposable cups as a cue for different coffee orders. I felt like I was being a nuisance and my (reusable) cup disrupted their system so ended up not taking them any more.”

On the other hand some participants voiced problems with re-use cups. These included forgetting to wash the cups and cups leaking in bags. Further, a number of participants also disliked some materials for the cups, especially plastic and silicon, which may take on the smell of drink over time. In addition to forgetting

to bring the cups, forgetting to, or running out of time to, wash cups was another significant comment received during the informal interviews. While having clean cups was important, some participants also suggested that if the cup belonged to themselves, it would not matter if it was a little unclean. It was also interesting to note that refill cups mostly belonged to one owner, rather than being shared.

At the farmers' market, a similar precedence is seen in the cloth bags as an initiative to reduce plastic bag waste. Although tangible incentives are not offered at the farmers' market, and plastic bags are still available, alternatives to plastic bags have become a part of the norm. As a part of material culture, some visitors assert their identity through the bags. These bags include cane baskets, contemporary collapsible baskets, shopping trolleys with wheels as well as cloth bags that are connected to memories, such as those purchased during travel. On the other hand, there is a social stigma attached to plastic bags as to whether this is correct behaviour. During informal interviews, some participants talked about experiences when they forgot their bags and felt uncomfortable because they were using plastic bags.

5.3.6.1 DISCUSSION

Given the current problem with the large amount of coffee cup waste, the introduction of systems to better accommodate re-use cups may result in significant impacts in waste minimisation. In terms of Shove's 3Cs, re-use cups may offer the perception of cleanliness, due to the fact that this prevents contamination and, in turn, provides comfort. Further, the aspects of social comfort revealed through reuse bags were a significant aspect of transitioning from the norms of plastic bags to cloth bags. For the purpose of this research, consideration will be given to re-use cups in relation to Shove's 3Cs.

5.4 SUMMARY AND DESIGN BRIEF

The insights gained from the observations and interviews held at the farmers' market identified wide areas of scope for design towards waste minimisation. Figure 5.8 summarises the findings from the observation accompanied with useful insights for forming a design brief.

The food packaging audit and introducing new rules of food packaging resulted in a positive change to the waste stream. Further, the waste audit was instrumental in identifying that paper waste, in particular disposable coffee cup waste, was the largest contributor by weight and contamination to the waste stream. Meanwhile, the nuanced areas of prior knowledge and assumptions that visitors bring to the market indicated the importance of clear communication to improve waste disposal bins. Further, the waste audit showed there is future scope for extending the waste minimisation from farmers' market visitors waste to vendors waste. Designing a waste separation system that can be seamlessly used by a large audience will benefit this site.

Figure 5.9 Observation Analysis and Insights

1. FOOD PACKAGING AUDIT

OBSERVATION RESULT

Introducing rules and policies for start of waste stream can have significant affection end waste.

INSIGHT

It is important to design appropriate packaging with respect to how the waste may be treated locally at the end of life.

2. WASTE AUDIT

OBSERVATION RESULT

Disposable coffee cup waste and paper waste made largest contribution to waste stream.

INSIGHT

Considering coffee consumption practice to design ways of making positive impact is a pressing issue for this farmers' market.

3. MARKET VISITORS

OBSERVATION RESULT

Visitors are interested in correctly separating waste. However, current separation bins are difficult to understand.

INSIGHT

Designing waste separation systems with convenience and clarity at the point of waste disposal will empower visitors with positive attitudes to waste separation.

4. COMMUNICATION

OBSERVATION RESULT

Visitors to the farmers' market bring with them multiple perspectives and understandings of waste separation and ways of recycling.

INSIGHT

A design intervention must be clear to over ride any incorrect assumptions that may lead to contaminating a waste separation stream.



5. SOCIAL COMFORT

OBSERVATION RESULT

“Doing the right thing” with waste separation is important for a large number of visitors.

INSIGHT

Taking into consideration Shove’s view of social comfort for this project may lead to a system that is self-governing by the visitors to the market.

6. RE-USE CUPS

OBSERVATION RESULT

Re-use cups present a number of problems: forget to take the cup: forget to wash the cup: coffee vendors’ systems are not conducive to re-use cups.

INSIGHT

Can re-use cups become a part of the norm in the same way as the recent shift to cloth bags at the farmers’ market ?

7. COFFEE DISPOSABLE CUPS AND WASTE SEPARATION

OBSERVATION RESULT

Disposable coffee cups, along with other paper waste contributed to the largest source of contamination to waste stream.

INSIGHT

Users often did not take time to separate coffee cups from lids, which added to contamination. Also see 4, Communication.

8. COFFEE DISPOSABLE CUPS AND THE 3CS

OBSERVATION RESULT

Disposable cups are an essential part of the current take-away coffee practice and for trading drinks at site.

INSIGHT

Disposable coffee cups embody Shove’s 3Cs. This may be one of the reasons why this trade has become dependent on this material.

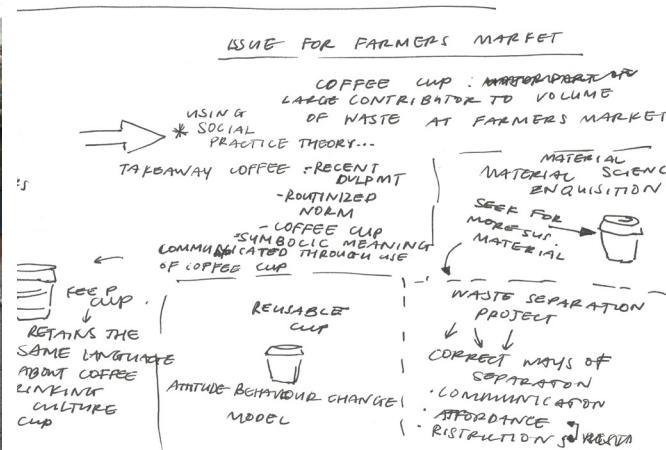

CHAPTER SIX: DESIGN IDEATION AND EVALUATION

6.0 DESIGN CONCEPT AND EVALUATION

This chapter discusses the design ideation and refinement phases of this research. The ideation concepts were generated for a design brief: To improve the landscape of food waste at the farmers' market through designing interventions for take-away coffee practice. This design ideation was also used as a platform to assess how Shove's 3Cs informed the design ideation process.

6.1 METHODOLOGY

The design ideation phase continued the application of the Human Centred Design methods. These methods were considered suitable for the research objective of exploring ways to shift behaviour surrounding food waste. The brief was used to generate a suite of possible design interventions. From this suite of possibilities, three design concepts were selected for further refinement. These concepts were selected for a design concept that:

1. demonstrates the possibility of shifting behavioural norms related to the take-away coffee practice and the use of disposable cups;
2. is informed by issues surrounding Shove's 3Cs and other design for sustainability frameworks;
3. resolves some issues identified at the farmers' market and associated coffee consumption.

The three design concepts were refined and then evaluated against previous research and observation analysis for key design challenges for future refinement. In order to assess the applicability of Shove's 3Cs and other sustainability frameworks, the design concepts were analysed for their relevance to the theoretical positions of design for sustainability.

6.2 RATIONALE FOR THE DESIGN BRIEF

The design brief was generated with two major considerations. First, to respond to the analysis from the farmers' market observation. Second, to locate an area for design with relevance to Shove's 3Cs so that the applicability of Shove's 3Cs to design ideation could be assessed.

6.2.1 DISPOSABLE COFFEE CUPS

The issues identified around take-away coffee practice were as follows:

- Disposable cups made a large contribution to overall waste generated from the farmers' market.
- Disposable cups were a major source of contamination for waste separation.
- Contamination of waste separation was partly due to the cups often not being separated from the plastic lids for disposal.
- Various forms of visitors' prior understandings for the separation of disposable cup did not match the intended waste separation system.
- Re-use cups were rarely seen in use at the farmers' market.
- Disposable cups were an essential part of the coffee trade at the farmers' market.

This observation analysis surrounding take-away coffee practices makes this area crucial for design intervention.

6.2.2 DISPOSABLE CUPS AND SHOVE'S 3CS

Disposable coffee cups embody Shove's 3Cs in the same way as the single portion spread packaging (described in 4.4.1). Disposable cups are convenient for both vendors and consumers, while providing comfort and cleanliness. The perceived sense of cleanliness and hygiene is directly related to each consumer receiving a new disposable cup. A new cup provides assurance that contamination is prevented and ensures protection of self against others. This peace of mind offers emotional comfort.

However, an area for further improvement of convenience for disposable cups may be the plastic lids. The importance of convenience was displayed in the lack of willingness by visitors to separate paper coffee cups from plastic lids. Designing for further convenience at the point of disposal by examining the current lid may improve waste separation.

6.2.3 TAKE-AWAY COFFEE PRACTICE AND SHOVE'S 3CS

Coffee drinking practice can be analysed through Shove's 3Cs. Elements of coffee drinking practice were also identified to generate a schematic to apply to design concept generation. Figure 6.1 displays the analysis of elements of coffee drinking practice broadly categorised into three areas; practice and rituals; materials; and meanings. Each of these areas contained a number of elements that were significant to consider in design concept generation.

Figure 6.1 Elements of Take-Away Coffee Practice

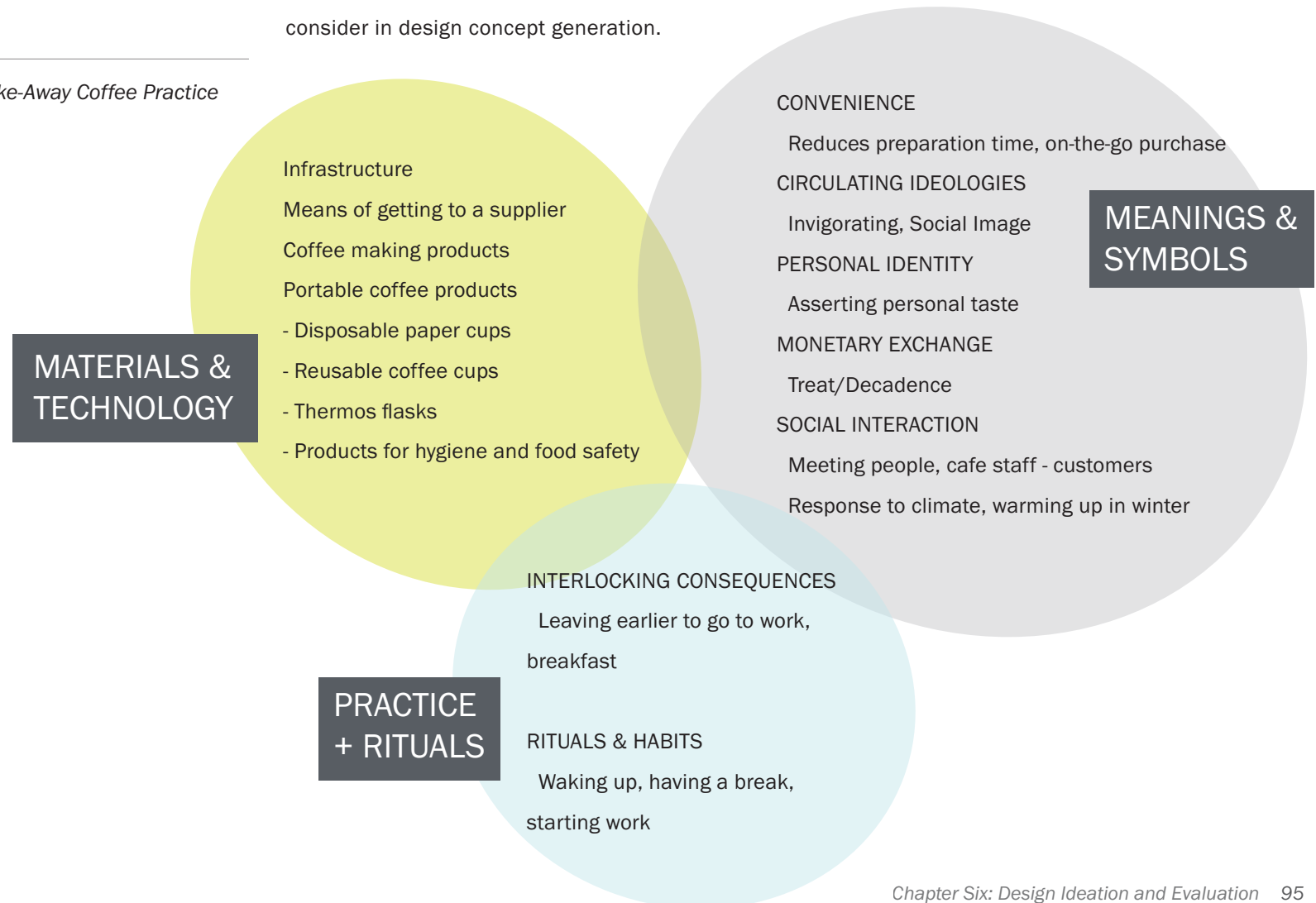

6.2.4 WASTE MINIMISATION INITIATIVE AND ITS PRECEDENCE

The food packaging audit outlined in section 5.3.2 and consequent rules that were enforced on vendors led to significant improvement in the farmers' market waste stream. The improvement was evident through comparing the periodic waste audits results. The design ideation assumes that this precedence may be repeated if an improved intervention to the current disposable coffee cup can be designed. Combining an improved product with the packaging audit initiative would ensure a positive impact to the environment that cannot be achieved purely as a product intervention.

6.2.5 FUTURE SCOPE

The issue of waste generated from disposable coffee cups extend beyond the local farmers' market to international take-away coffee consumption practice. In New Zealand alone, the major manufacturer and distributor of disposable coffee cups, Huhtamaki, distributes one hundred eighty million disposable coffee cups each year (Gibson, 2011). These cups are distributed to coffee vendors throughout New Zealand. Interventions in this area can be scaled to further outdoor food sites and cafés.

6.3 SUITE OF DESIGN CONCEPTS

A number of possibilities were considered to generate a suite of concepts (Figure 6.2, 6.3 and 6.4). These were as follows:

- Re-design disposable cups and re-use cups
- Encourage on-site consumption
- Explore ways to wash personal cups on-site at cafes
- Assess ways to prolong use phase of re-use cups and disposable cups

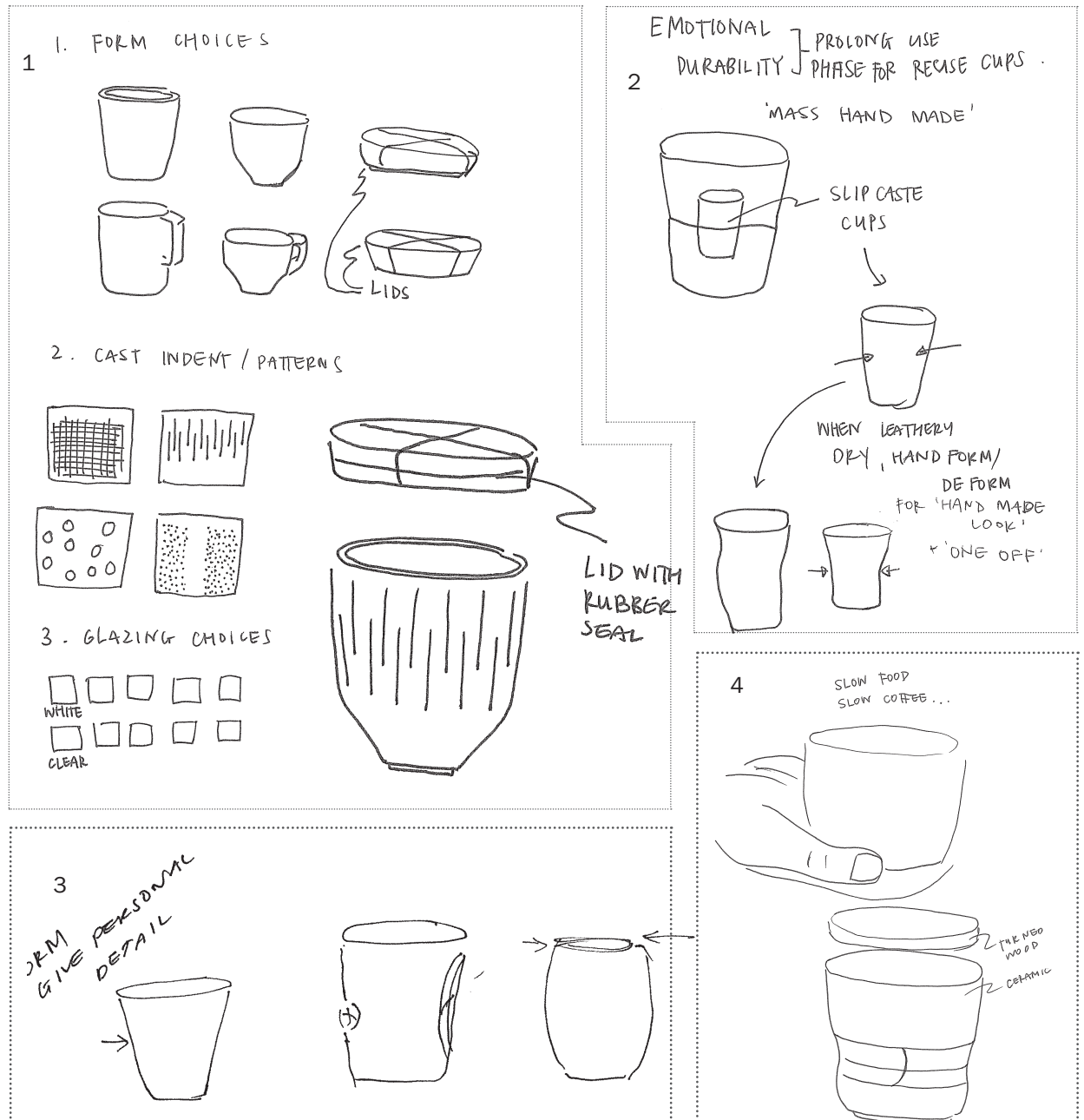

Figure 6.2 Ideation Sketches 1

1. Personalisation, 2.,3. Emotional Durability through adding hand forming to slip cast cups,
4. Encourage on-site consumption.

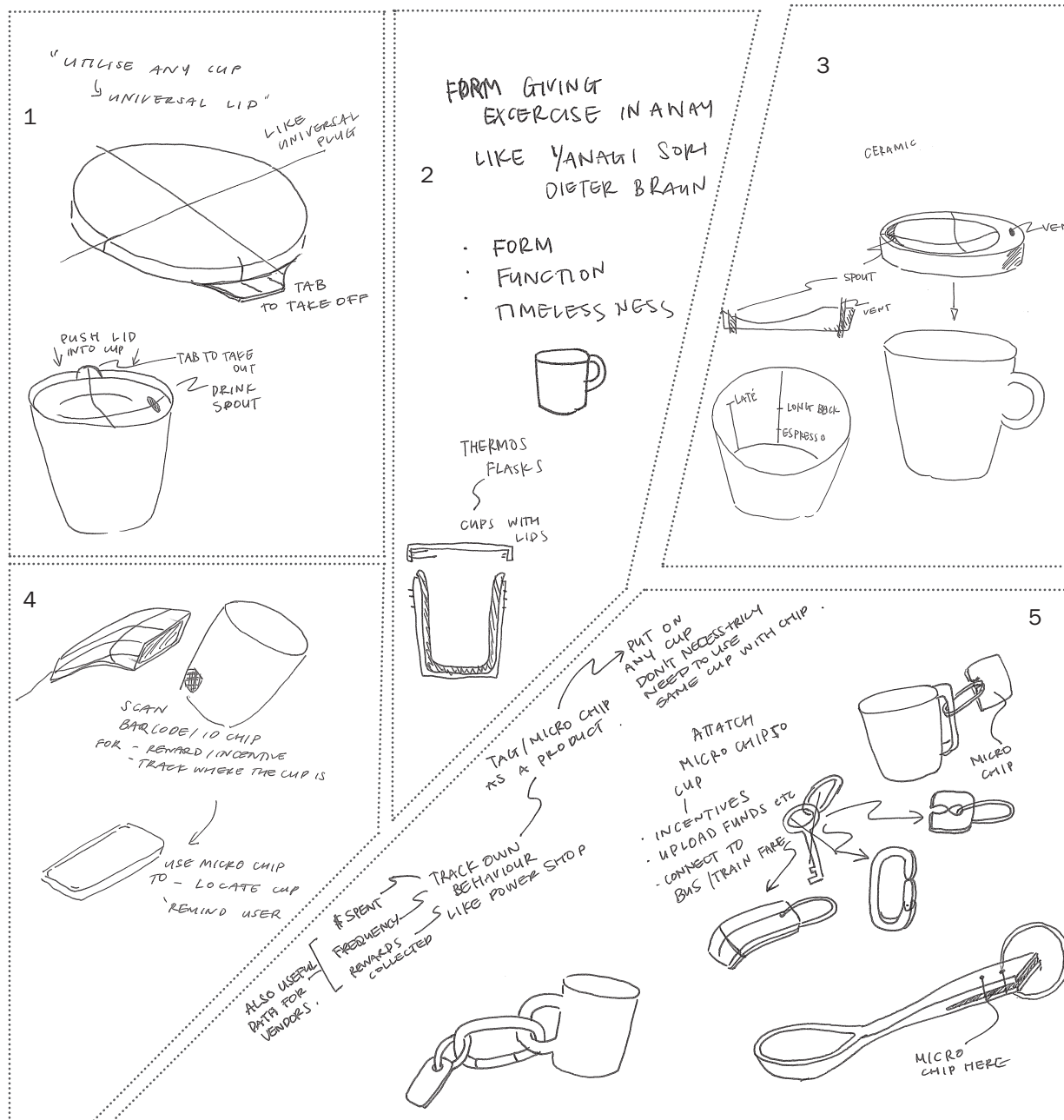

Figure 6.3 Ideation Sketches 2

1. Universal Lid for any coffee cup 2.,3. Emotional durability 4. Measurements of various coffee in cup 5. A tag to be placed on cups to be scanned at cafes for related rewards and information on environmental impact of the coffee cups.



Figure 6.4 Ideation Sketches 3

1. Exploration of washing re-use cups 2.,3. Emotional durability through adding hand forming to slip cast cups, 4. Dye cutting tool for bottom of the cup to turn to planter. 5. Site specific cups with marking to take home

6.3.1 SELECTION OF THREE CONCEPTS FOR REFINEMENT

The three concepts, disposable cup re-design, re-use cups and a device for washing cups were selected for refinement after reflecting on the rationales discussed in section 6.2. First, disposable cup re-design explored the role of Shove's 3Cs and ways of eliminating hybrid materials. Second, the re-use cup examined Shove's cleanliness and comfort and prolonging the use phase through Chapman's (2009) emotional durability. The final concept challenges routine behaviour change with the application of Shove's 3Cs.

6.4 DESIGN CONCEPT ONE: DISPOSABLE COFFEE CUP RE-DESIGN

The observation analysis identified that the landscape of coffee consumption does not always allow visitors with the most pro-environmental attitude to have a refill cup at hand. In these cases, the disposable cup proves necessary for the consumer as well as for the vendor to support economic sustainability. Therefore, the first concept explores ways of designing a more sustainable disposable cup. This cup will provide for Shove's 3Cs, which consequently may increase the demand for this potentially more sustainable alternative.

6.4.1 OBJECTIVES:

To re-design a disposable coffee cup that is suitable for environments such as a farmers' market as well as for take-away coffee consumption. The cup must be compostable to align with the farmers' market waste stream and, where possible, hybrid materials should be avoided.

6.4.2 RELEVANT OBSERVATION INSIGHTS

- Disposable cups play an important role for consumption in public sites and cannot be eliminated in the short term.
- Currently coffee cups are made of hybrid materials: plastic lid, paper cup, and biodegradable film.
- Cups and lids were often not separated for disposal.
- Coffee cups were problematic for waste separation.
- Implementation of an ideal cup across the farmers' market could result in a large impact to the waste stream in the same way as the packaging audit in Section 5.3.2.

6.4.3 RELEVANCE TO THEORY

The disposable cup embodies Shove's 3Cs, altering the elements of the cup in ways that accelerate the demand for a more sustainable cup. Simplify a monstrous hybrid (Shedroff, 2009) of current disposable coffee cups that are made of plastic lid, paper and plastic film. The aim is to simplify the material makeup of the cup.

6.4.4 DESIGN CONCEPT

The final result eliminated the monstrous hybrid concept by altering the plastic lid to one that is made of the same materials as the body of the cup, paper stock and biodegradable film (figure 6.5). At the point of disposal, this cup will not require separation between cup and lid, therefore offering convenience to users. The biodegradable nature of both the cup and the lid improves the waste separation for such sites as the farmers' market that pursue composting of paper-based waste. The lid was developed by taking cues from the current construction method of the cups. Re-designing a disposable coffee cup that is more convenient at the point of disposal by eliminating the plastic lid supports consumer's needs at waste separation.

Figure 6.5 Disposable Cup Re-design

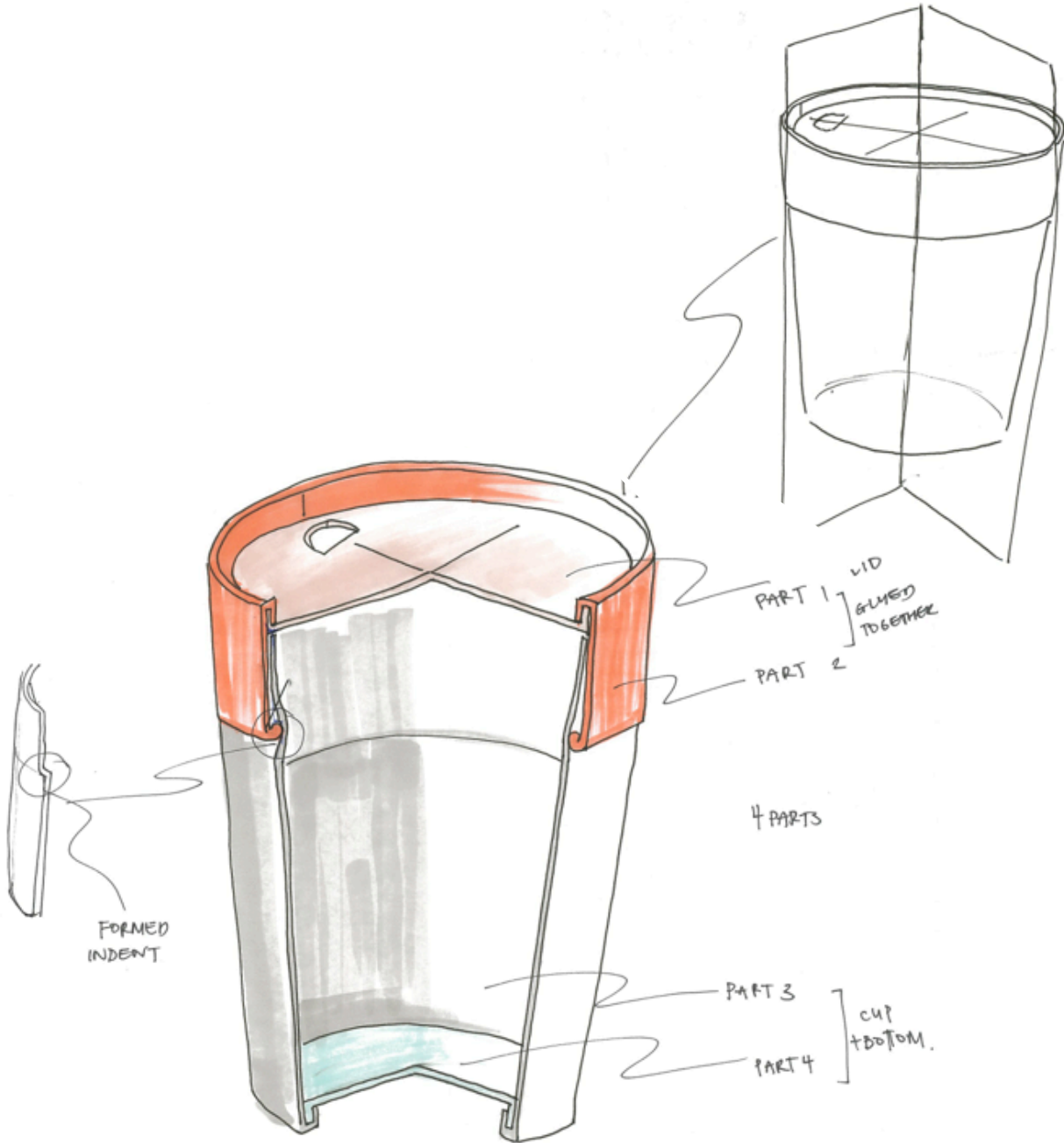

6.4.5 SCENARIO FOR USE

SCENARIO 1

Lucy and John visit the farmers' market to have breakfast. They buy specialty bread and coffee and sit at the provided table to enjoy their breakfast. All service is treated as take-away for the vendor's convenience, so Lucy and John receive coffee in disposable cups and bread in a brown paper bag.

Separating waste for Lucy and John is normal for them, having just shifted from a city that was proactive with waste separation. After they finish eating they find the centralised waste separation station and look for the appropriate bin for their paper waste. This is straight-forward as they find a bin stating "paper and organic waste."

Using their prior knowledge they assume that this waste must get incinerated. This is not the case for this farmers' market that composts this material, but none-the-less, their assumption does not interfere with waste separation.

SCENARIO 2

Kelly arrives at the farmers' market on a cold winter day and decides to treat herself with hot chocolate from a coffee vendor to warm herself up. It is so cold that, as soon as she finishes her drink, the cup gets cold in her hands. She quickly finishes shopping and hurries back to her car. On the way back to the car park, she disposes of the cup in the waste separation bin that already had many cups in it.

SCENARIO 3

Julie always makes an effort to come to the farmers' market for coffee and to buy her weeks' worth of groceries. She realises that the plastic lids on the coffee cups have been replaced with paper ones. She quite likes this because it's a bother to get her hands dirty by taking the lid off to separate for recycling. In the past she sometimes saw the inside of the bin and followed suit with many others who did not their lids off. She assumed that it would not harm recycling because the waste from the market would probably go to the same system as the city recycling where someone sorts it out.

6.4.6 DESIGN EVALUATION

6.4.6.1 KEY CHALLENGES FOR FURTHER REFINEMENT

1. At the end of use life, the cups need to be either recycled or composted for environmental benefit.
2. The biodegradable film applied to the paper must be one that complements the composting system.
3. Recycling this product requires the participation of a number of stakeholders to collectively work towards either recycling or composting the cups.
4. The resulting cup must be accompanied with supporting materials that communicate the environmental benefit of the cups to gain interest from both coffee vendors and consumers.
5. Technological aspects of actual composting and recycling are future areas for research.
6. Cups and lids both need to be stackable for efficient transportation and storage.

6.4.6.2 PAPER COFFEE CUP AND SHOVE'S 3CS

This design concept applied Shove's 3Cs to examine the possibility of accelerating the demand for a more sustainable product through catering for the 3Cs (2003). Shove argues that meeting the demand for the 3Cs accelerates the rate of consumption. The disposable nature of coffee cups may be one of the agents that accelerated the take-away coffee practice that is prevalent today. Therefore, the 3Cs embodied in this design concept of a disposable coffee cup may further accelerate the rate of consumption. This would lead to negative environmental impact if this cup discourages the alternative re-use cups. Further, the positive consequences to the waste stream are dependent on a wider scheme to ensure the cups are composted or recycled. Assuming that the cups are composted or recycled at the end of life, keeping in mind that disposable cups are necessary part of the current coffee practice, this cup and the embedded 3Cs may contribute to a positive environmental impact.

6.4.6.3 DISPOSABLE CUP AND CONSUMER RESPONSIBILITY

This re-design of a disposable coffee cup would have a positive impact on the farmers' market waste stream if the packaging audit discussed in section 5.3.2 was repeated to ask vendors to use the re-designed cups. All consumers receiving the same cups will be more convenient and straight-forward at the time of disposal. In addition, for the waste stream, the resulting affect of this cup may be less contamination of the waste separation bins by eliminating the plastic lids for the cups. Therefore, the rule driven approach to introduce more suitable disposable cups for the farmers' market may result in a positive impact to the waste stream.

However this approach assigns the responsibility for improvement of waste separation on the vendor and raises a question over consumers' responsibility (Thorpe, 2010). A positive consequence of this design intervention would be if visitors to the farmers' market practice informed choice. Taking cues from the farmers' market to demand that other coffee vendors re-consider coffee waste would transcend the efforts of the farmers' market to a wider take-away coffee practice. However, for a such result, this product-led design intervention would require a larger supporting scheme to further improve the handling of disposable coffee cups.

6.5 DESIGN CONCEPT 2: RE-DESIGN RE-USE CUP

In response to the first concept, which if implemented, would place responsibility on coffee vendors, this concept explores consumer responsibility through a re-use cup. This design concept, therefore, explores ways of encouraging re-use cups through the application of Shove's 3Cs with Chapman's emotional durability framework.

6.5.1 OBJECTIVES

To design a re-use coffee cup to encourage its prolonged use with consideration to the application of Shove's 3Cs and Chapman's (2009) emotional durability frameworks.

6.5.2 RELEVANT OBSERVATION INSIGHTS

- Disposable cups are one of the largest contributors to the waste stream at the farmers' market. Visitors bringing re-use cups would significantly reduce waste.
- Although reusable cups are readily available in the market, currently there is very little evidence of re-use cups at the farmers' market.
- Reusable cloth bags and market baskets have become a part of the landscape of practice at the farmers' market. In the same way, can reusable cups become part of the norms of practice?
- A visitor described that while her reusable cups were not declined from coffee vendors, there was little allowance for re-use cups within the vendors' systems.

6.5.3 RELEVANCE TO THEORY

SHOVE'S 3CS

Reusable cups provide cleanliness and comfort. Contamination between users can be avoided as a consequence of using a personal re-use cup. This assurance in turn provides emotional comfort or peace of mind for the user. Further, the re-use cup has been instrumental in reversing the responsibility for hygiene of the cup from the vendor to the consumer. In the current local examples, consumers must clean the cup before taking it to vendor. This shift is a compelling example of change in norms of responsibilities, which has occurred through a product intervention, namely a re-use cup.

CHAPMAN'S EMOTIONAL DURABILITY

Re-use cups are produced with larger embodied energy than the disposable counterpart. The prolonged use of re-use cups is crucial in making a positive impact on the environment. Chapman's Six Point Experiential Framework for emotional durability was applied for the ideation as a way of exploring the longevity of use phase.

6.5.4 DESIGN CONCEPTS

Emotional durability offered a practical application to the design ideation process. Four aspects of the frameworks were applied: Surface; Attachment and Detachment, Delight and Narrative. The concept is displayed in figure 6.6.

6.5.4.1 SURFACE

This re-use cup is designed with a copper exterior to consider surface wear of the cup. The copper surface will create patina over time, which users could enjoy as a part of the constantly-changing nature of the cup. Similarly, the cup could be manufactured with other materials, such as brass that also build patina over time.

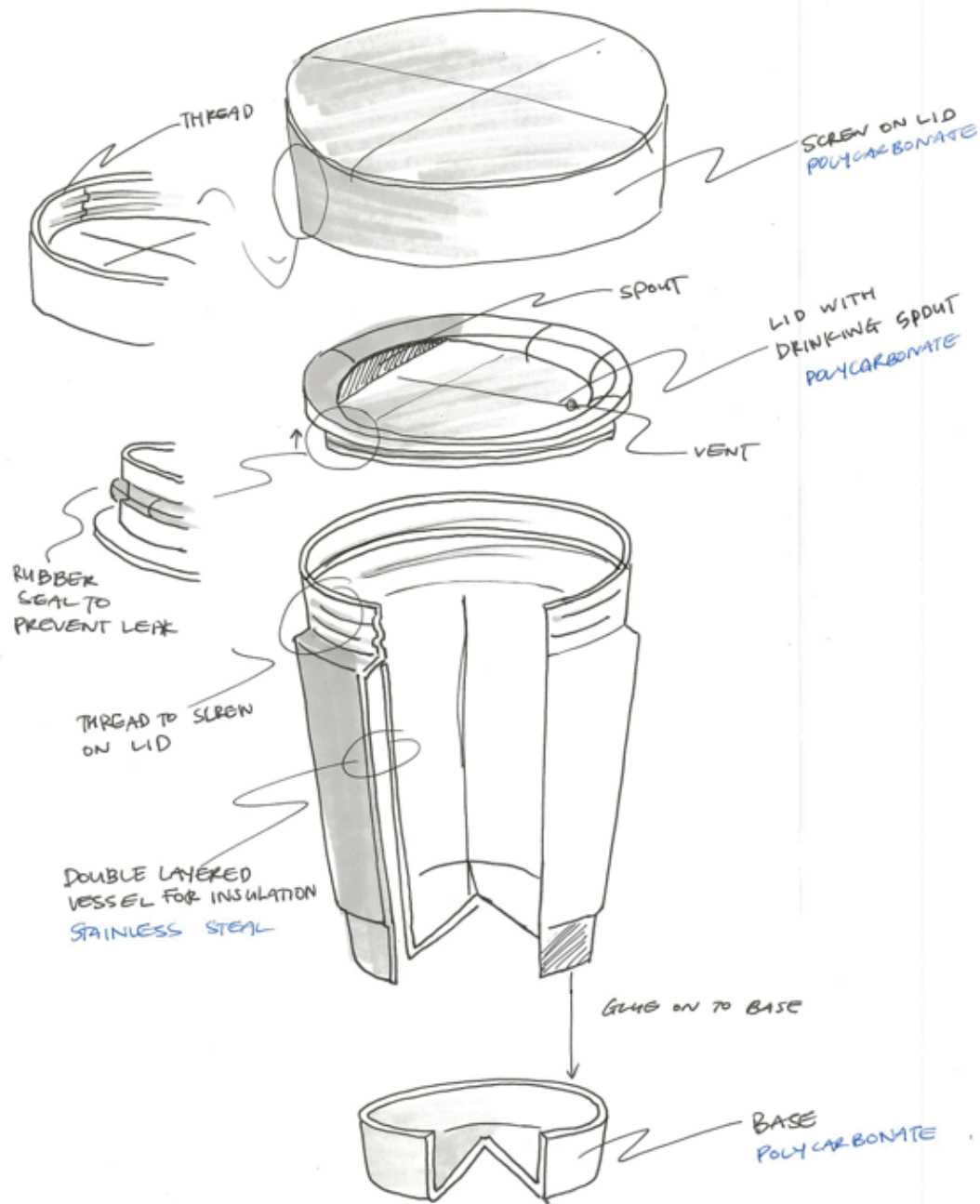

Figure 6.6 Re-use Cup Re-design

6.5.4.2 ATTACHMENT AND DETACHMENT

Consideration of the Attachment and Detachment framework resulted in a re-use cup that was as functional as possible. The interior of the cup is made of stainless steel with the capacity to insulate the drink in the form of a thermos flask. In addition, the screw-on lid has been provided to meet the needs of users who voiced concerns about a leaking cup when carried in a bag. This concept explored the theory of *attachment* through designing a functional product. Later, in the use phase, when the user is *detached* from the product, the cup will continue to be used for its functionality.

6.5.4.3. DELIGHT

In response to Delight, a series of personalisation schemes for the refillable coffee cup was drafted. The Delight framework proposes that products can be explored further to enchant users. For example, technological products embody this framework when users can continuously find different uses over time. However, for the more simple re-use cup product, ways of offering choices were explored to provide Delight. Therefore, personalisation options were drafted for this cup to offer users a selection of exterior materials and possible patterns to be etched on to the material.

6.5.4.4 NARRATIVE

Further to Delight, mass customisation may result in enforcement of the product. The resulting product embodies physical characteristics of personal choice and an accompanying narrative for the reasoning behind each selection. This narrative may further provide emotional durability and hence a prolonged use phase for this product.

6.5.5 SCENARIO FOR USE

SCENARIO 1

Katherine recently went travelling and bought herself a re-use cup. She really likes to use the cup all the time so keeps it in her handbag. She bumps into an old friend at the farmers' market and they decide to have a coffee for a quick catch up. She is pleased the cup was in her bag for this spontaneous coffee purchase.

SCENARIO 2

John was given yet another re-use cup for Christmas. This time however, his friend found one that wasn't made of plastic, which is a material he dislikes drinking from. He decides that this time he might try to use this cup instead of disposable ones. Besides, many of his colleagues use re-use cups when they go out for a coffee break and that makes him feel a little guilty.

SCENARIO 3

Natasha has a keen interest in environmental issues and making personal changes towards positive environmental affects. She believes that when it comes to re-use cups, it is better to get one that can be used for a long time. Therefore, she decided to invest in a metal re-use cup with insulation and a screw-on lid so that she can keep it in her bag and try to use it as often as possible.

6.5.6 DESIGN EVALUATION

6.5.6.1 KEY CHALLENGES FOR FURTHER REFINEMENT

- At the end of life, this product must be disassembled to separate the materials for recycling.
- Surface considerations contributed to this particular design outcome in materials with a large

environmental impact such as copper and steel. Further research is necessary to explore materials that allow for surface considerations while having less environmental impact.

- Re-use cups require commitment from users as well as coffee vendors to accommodate the product.
- This product would benefit from further systems design so that the re-use cup can seamlessly intergrate into the current coffee practice.

6.5.6.2 SHOVE'S 3CS AND RE-USE CUP

This product explored ways of designing a product to alter user behaviour. The evaluation of re-use cups against Shove's 3Cs emphasises the importance of the element of convenience for re-use cups. Although the cup can be assessed to embody both cleanliness and comfort, these two elements alone do not accelerate the demand for re-use cups.

6.5.6.3 EMOTIONAL DURABILITY

Emotional durability provides practical applications for potential ways to design products for which users can develop emotional attachment. For example, surface wear considerations act as a rough guideline to designing for prolonged use. This framework was valuable to explore the issues surrounding the relationship between industrial designers' intentions and actual use. Emotional attachments to products are indeed derived from an array of contributing factors. The Narrative aspect of this framework, in particular, highlighted that emotional attachments to products are derived from a vast range of contributing factors. Many of these elements are beyond the control of designers, such as occasion or from whom the product was gifted. However, this framework provided a set of considerations that were useful during the design ideation phase and highlights an area with scope for future study.

6.5.6.4 ATTITUDE BEHAVIOUR RELATIONS

Attitude behaviour relations (Ajzen & Fishbein 1977) is an important aspect for prompting both efficiency and curtailment behaviour (Abrahamse et al. 2007). Re-use cups require commitment to not only purchase the re-use cup but also to continue the use of the cups. This commitment would more likely be taken by those who are primed with a positive attitude towards re-use cups and their related impact on the environment.

6.5.6.5 DESIGN PRECEDENCE: KEEP CUPS

'Keep Cup' is a leading example of an Australasian re-use cup product that has raised awareness of the impact of disposable cups to the waste stream (Figure 6.7). Given the on-going use of a Keep Cup, its environmental benefits span across areas, such as embodied energy, land use, water use and solid waste (Lockrey 2011). Further, this cup is an example of a product that directly mimics the shape and size of what has become the conventional disposable coffee cup. As a result users are able to make the connection visually for the purpose of this cup and it is also practical for coffee vendors. Further, in a manner similar to my own ideation phase, Keep Cups offer ways of personalising through a combination of colours. Therefore Keep Cups offer disposable cups that resonate with the emotional durability frameworks.

6.5.6.6 RE-USE CUPS AND USE BAG PRECEDENCE

The Packaging audit discussed in section 5.3.2 may an approach that could be applied to help reduce the use of disposable cups at the farmers' market. However, a more favourable way of shifting norms around coffee consumption would be to find ways to replicate the situation with cloth bags that became a significant part of the landscape at the farmers' market. Further research of this precedence may uncover ways to rapidly encourage re-use cups at the farmers' market.

Figure 6.7 Keep Cup (2012)



6.6 DESIGN CONCEPT 3 : RE-USE CUP WASHER

The evaluation of the previous re-use cup suggested that further exploration in shifting routine norms for current coffee consumption is ideal. The refined concept therefore applied Shove's 3Cs to a design intervention that may accelerate the demand for re-use cups.

6.6.1 OBJECTIVES:

To design a device that washes re-use cups at the site of consumption to provide for 3Cs.

6.6.2 RELEVANT OBSERVATION INSIGHTS

- Re-use cups raise the issue of consumers' and vendors' responsibility for hygiene. In conventional coffee service, vendors are responsible for hygiene. By contrast, re-use cups allocate responsibility for hygiene of the cups to the consumer.
- One of the barriers to re-use cups is that the cup may not be clean at the time of coffee purchase.
- After consumption, residual liquid in the re-use cup can spill out.
- When some re-use cups are not cleaned for a period of time the material make up of the cup, such as silicone or Polyethylene Terephthalate Plastic (PET) can absorb the smell of the liquid. This makes it unpleasant for continued use.
- For re-use cups to make a more positive impact on the environment than disposable paper cups, the use phase must be prolonged to counterbalance their embodied energy.

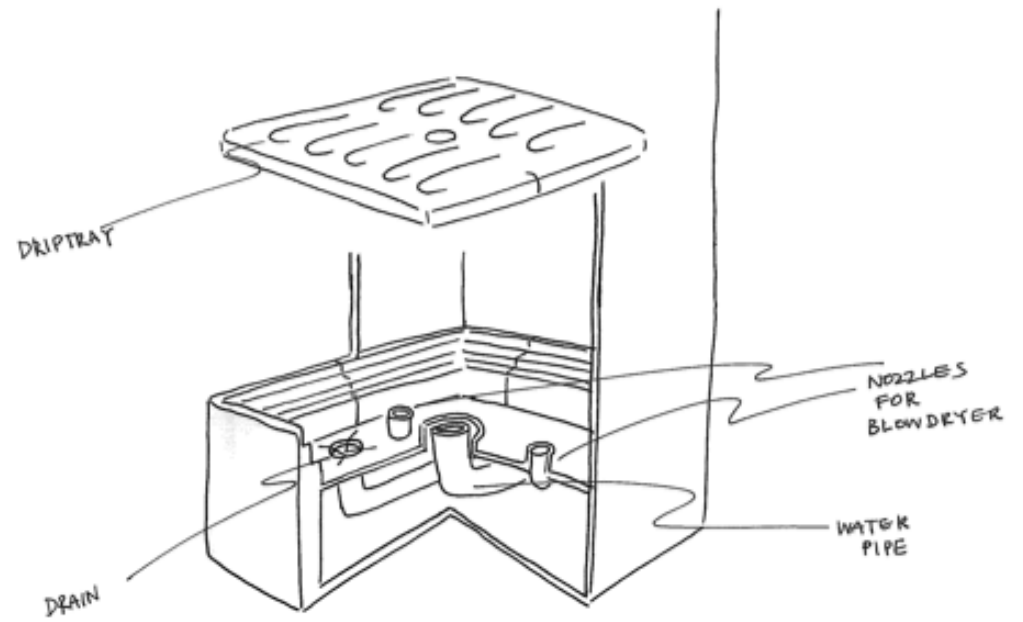
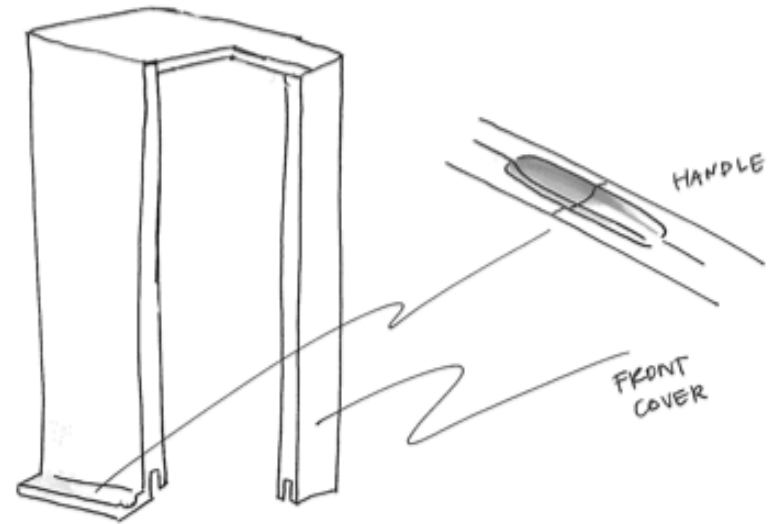
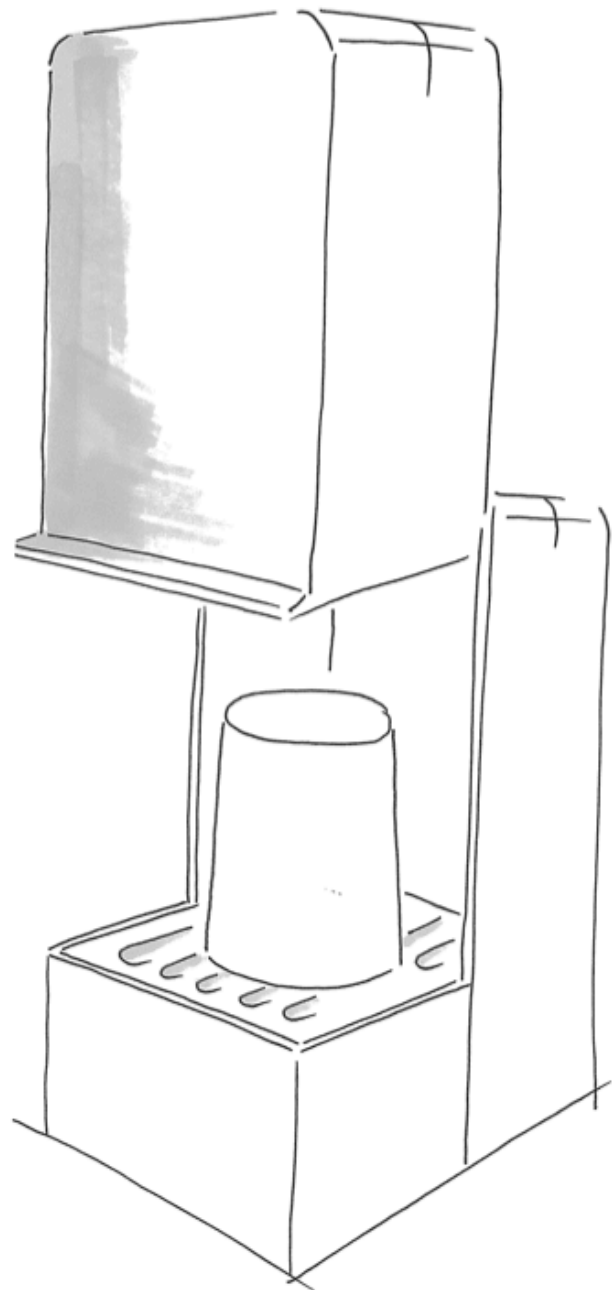

6.6.3 RELEVANCE TO THEORY

SHOVE'S 3CS

One of the barriers to re-use cups was that they need to be clean at the time of coffee purchase. This design concept examines the role of cleaning devices for re-use cups to provide the 3Cs as one of the ways of shifting the routines around take-away coffee purchase.

6.6.4 DESIGN CONCEPT

The re-use cup washer is a device to wash cups at the site of consumption to encourage consumers to use re-use cups (Figure 6.6).

6.6.5 SCENARIO FOR USE

SCENARIO 1

A regular farmers' market visitor, Ann, arrives in her car and grabs her re-use cup from her dash-board and puts in her cane market basket. The cup has been sitting in the car for a couple of days and has a little residue of coffee from the last use. She approaches a coffee vendor and puts the cup in the cup wash device to clean the cup. She then hands the clean cup to the coffee vendor as she places her order. The vendor is pleased to have peace of mind that the coffee is served in a hygienic cup, which not only ensures the quality of coffee but also confirms that he is not liable for any implications of unhygienic service.

SCENARIO 2

Chris leaves his office with his coffee cup to visit his local café. Although he could have washed his cup in his office kitchenette, he finds it easier to wash his cup at the site of consumption in the cup washer. He hands over the cup to the barista with his usual order, and when it is ready, takes his coffee to consume it in his office and leaves the cup on his desk to use the next day.

Figure 6.8 Re-use cup washer

SCENARIO 3

Diane and her friend Tracy meet at the farmers' market for coffee. They have their coffee served in re-use cups they brought with them and enjoy catching up at a bench located near the café. When they are ready to go, they return to the coffee vendor to wash the cups and put the cups back in their bags, ready to be used the next time.

6.6.6. DESIGN EVALUATION

6.6.6.1 KEY CHALLENGES FOR FURTHER REFINEMENT

- This device requires financial commitment for both initial investment and ongoing energy consumption from the vendors and organisations.
- Further investigation and application of ways of washing utensils which are less energy consuming, such as Ultra Violet methods, is necessary.
- An interface to indicate how consumers and vendors interact with this product needs to be developed. This may provide a platform to test the wider applicability of product-led behaviour intervention approaches.
- Ways of keeping this device hygienic is an area for further consideration.

6.6.6.2 RE-USE CUPS AND SHOVE'S 3CS

The re-use cup washer embodies Shove's 3Cs in a similar way to discussions surrounding showering and washing machines. Shove argued that meeting the need for the 3Cs leads to acceleration of demand. Therefore, this may also be the case for the re-use cup washer to become part of the landscape of resource intensive cleaning devices with large environmental implications. In Shove's (2003a) discussion, the act of showering was described as a "blending of pleasure and duty (p407). A similar

blend may result through this device, which will consist of a duty to clean the re-use cup as part of the consumption practice and a convenient cleaning device that provides assurance that the cup is hygienic. This device will, therefore, provide the blending of both duty and assurance to drive the demand for this washing device. Further, this device concept demonstrates that take-away coffee consumption is a complex issue that can be described as Buchanan's (2001) wicked problem: attempting to resolve an area of problems creates further problems. In this case, a designed device to encourage adoption of re-use cups as a part of sustainability intervention has led to also creating a device that potentially is a more energy consuming.

6.6.6.3 RE-USE CUP WASHER, PERCEPTION OF CLEANLINESS

The perception of cleanliness plays a major role for vendors and consumers with respect to re-use cups. The perception of cleanliness can be based on multiple cues. Some are directly related to hygiene and protecting health of self. Other cues for cleanliness are more personal or cultural. Figure 6.7 seeks to consolidate elements of the meanings surrounding hygiene for a re-use cup washer by using Shove's discussion surrounding cleanliness (Shove, 2003a).

Figure 6.7 displays various connecting elements surrounding the re-use cup washer and social, cultural and personal cues for cleanliness. This implies an interplay amongst stakeholders' intentions in hygiene, including vendors, consumers and food safety governing bodies, who monitor the safe food handling practices of food vendors.

The cue for cleanliness for both consumers and vendors is governed by a vast array of external concepts of cleanliness. These concepts include ideologies, such as squeaky clean and smells, such as citrus scents. Detergents and temperature of water as well as ways of drying utensils after washing also play important roles, not only in actual cleanliness, but also in perceived cleanliness.

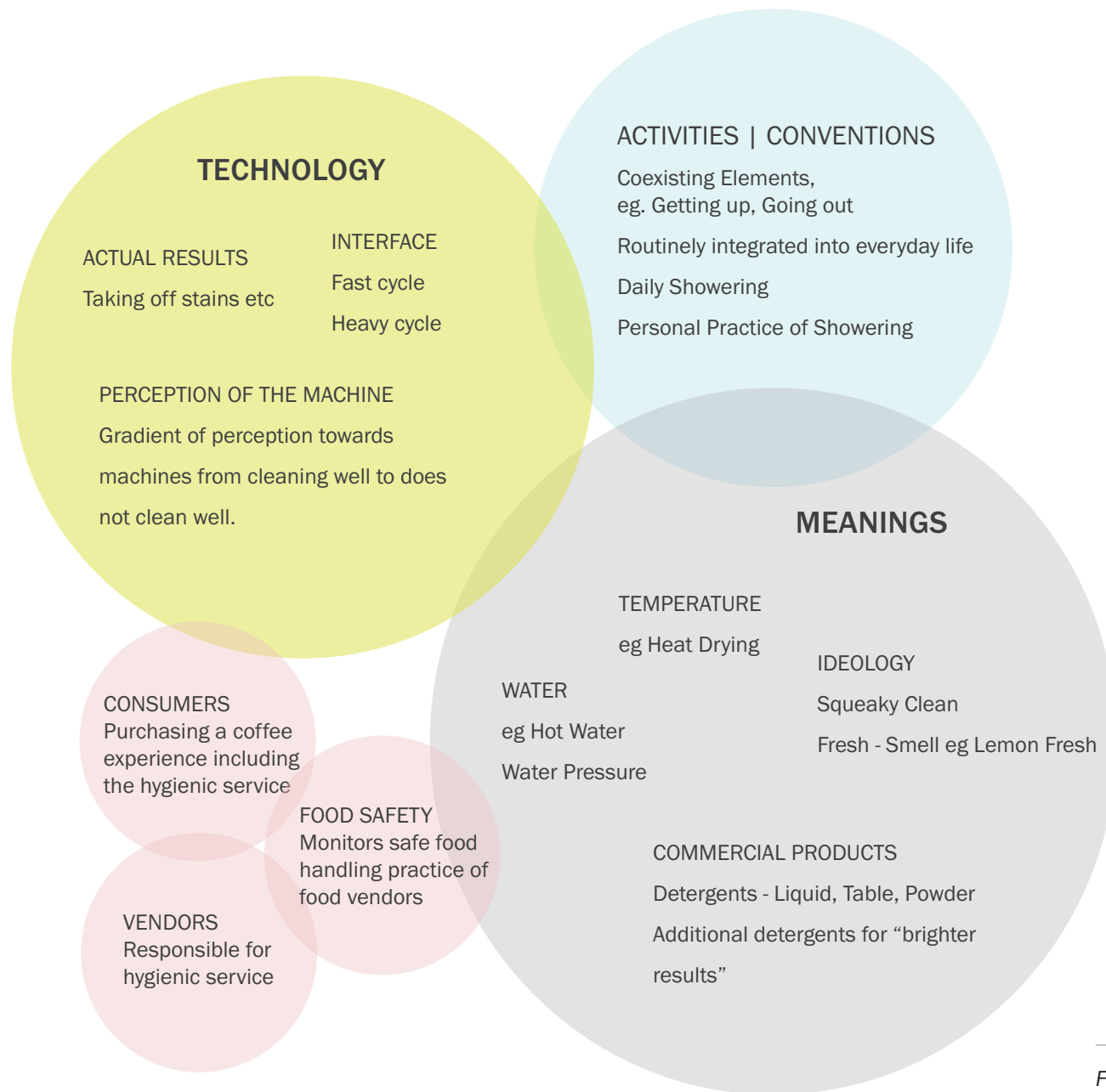

Figure 6.9 Elements governing cleanliness

The analysis of these elements informed the re-use cup washer concept

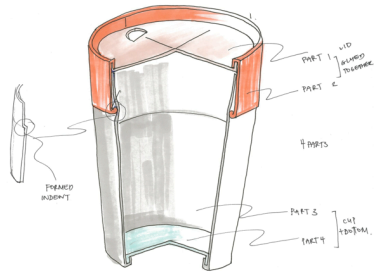

Figure 6.10 Concept 1: Disposable re-design

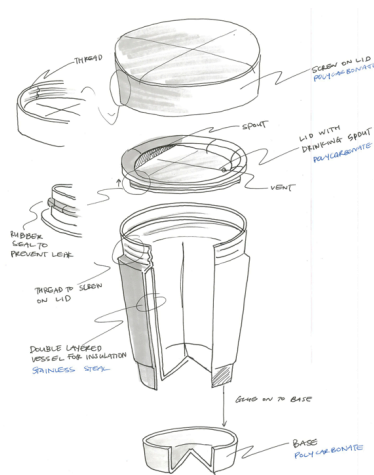

Figure 6.11 Concept 2: Reuse cup re-design

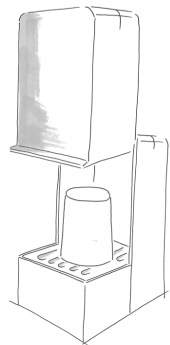

Figure 6.12 Concept 3: Re-use cup washer

6.7 SUMMARY

This chapter discussed the design concepts generated to improve the landscape of food waste at the farmers' market through designing interventions for take-away coffee practice. The refined concepts were: concept one, disposable cup re-design, concept two, re-use cup re-design and concept three, re-use cup washer. Each of the concepts were evaluated for the limitation of the designs and for their relevance to sustainability frameworks.

The analysis of concept one, the disposable cups benefited from Shove's 3Cs while it also raised the presence of consumers' responsibility for waste reduction. Therefore, consumer responsibility was explored through design of the second concept, re-use cups, which applied the emotional durability framework to explore ways of ensuring users' prolonged use of a product. Prolonging the use phase of this product may also benefit from attitude behaviour relation theory. The third concept, the re-use cup washer, examined the role of Shove's 3Cs as a way of shifting rituals and norms surrounding coffee drinking practice. The evaluation of this product revealed the complex nuances surrounding perceptions of cleanliness. Further analysis of this product against Shove's 3Cs indicated the potential for this product to accelerate the demand for further 3Cs and become a resource-intensive device.

CHAPTER SEVEN: DISCUSSION

7.0 DISCUSSION

This chapter examines the relationships between design for sustainability frameworks and the methodological approach explored in this research. The objective of this research was to examine and apply appropriate theories for design for sustainable behaviour. The following research questions were sought throughout the research:

1. How can current approaches and frameworks enable sustainable behavioural change?
2. Can Shove's 3Cs be extended to a wider sustainability context?
3. And if so, how can they inform the design process?

7.1 APPROACHES AND FRAMEWORKS TO ENABLE SUSTAINABLE BEHAVIOUR

This section will discuss how current design for sustainability approaches and frameworks enabled sustainable behaviour in this research. The literature review covered three broad approaches for sustainable behaviour: product-led interventions, attitude behaviour relations, and shifting everyday norms to ones that are more sustainable.

The first design concept, the disposable cup re-design, explored the idea of a product-led intervention, as discussed by a number of studies (Lockton et al., 2008; Lilley et al., 2005). This concept applied Shove's 3Cs to disposable cups and in particular attempted to provide convenience at the time of waste separation by eliminating the plastic lid. This product-led intervention sought to support the current practice of take-away coffee, rather than introduce a significant change in behaviour or system. This may be an accessible intervention that could lead to a more immediate impact on the farmers' market waste stream from landfill to compost.

The second design ideation concept explored ways of prolonging the use phase of a product life cycle through the application of emotional durability (Chapman, 2008),(section 6.5.3). This concept explored ways to enable more sustainable behaviour through the design of a product that is not only physically durable, but also connects with users through gaining emotional attachment. In a similar way to Lacey's

(2009) research, this concept explored ways of offering choices to prompt conscious engagement with the re-use cups. This, however, requires positive attitudes towards sustainability in order for users to be willing to take re-use cups to coffee vendors. Consequently, efficiency and curtailment behaviours (Froehlich et al., 2010; Kaskinen et al., 2009) become important issues for this product.

The third concept, a re-use cup washer, utilised Shove's 3Cs to explore how everyday practices can transition over time. The purpose of the design was to enable sustainable behaviour by eliminating a barrier to ideal behaviour. One of the barriers identified for re-use cups was that the cup was not clean when needed. Therefore, this product embodies the 3Cs to encourage more sustainable behaviour.

This research, culminating in three design concepts, therefore explored ways to enable sustainable behaviour through a variety of means:

- 1) eliminating barriers to ideal behaviour through product intervention was carried out to support current practices in a more sustainable way;
- 2) enabling sustainable behaviour through designing products to prompt emotional connection for longevity of the use phase; and
- 3) ways of supporting the demand for the 3Cs to shift the current norm to one that is more sustainable.

7.2 SHOVE'S 3Cs AND AN EXTENDED SUSTAINABILITY CONTEXT

This research identified that Shove's 3Cs was an effective tool to analyse the landscape of food waste. Various forms of relationships between Shove's 3Cs and food waste were analysed. First, the fundamental basis of Shove's 3Cs (discussed in section 2.6) reflected the analysis of single use disposable food packaging:

- a) The 3Cs embedded in everyday norms and rituals are responsible for shifting norms over time, for example the advent of disposable take-away coffee cups;
- b) catering for the 3Cs is resource intensive, as seen in the negative impact of disposable food packaging;

c) the 3Cs act as cogs to accelerate the demand for resource intensive conventions, such as on-the-go coffee consumption.

Second, the pilot observation in chapter four supported the suggestion that Shove's 3Cs may help identify barriers to ideal behaviour (Clune, 2010). For instance, the need for cleanliness and comfort could override some of the positive attitudes and behaviours towards food waste composting. Therefore, lack of cleanliness can be a barrier to ideal composting behaviour. This analysis also highlighted the fact that cleanliness often provided emotional comfort, or peace of mind. Emotional comfort as a consequence of cleanliness was a recurring theme that arose while applying the 3Cs to food waste.

In contrast, the system-based catering site revealed that behaviour of individuals surrounding food waste can be governed by the systems and the roles of individuals within the system (section 4.3.3). In particular, responsibilities for cleanliness shifted to catering staff, while convenience and speed of catering were of foremost importance to this site. In addition, social comfort resonated strongly with food waste separation at the farmers' market, where doing the right thing was important for large numbers of visitors.

These analyses supported the proposition discussed, in section 2.6.4, that locating Shove 3Cs at the design observation stage of the design process was, indeed, a useful entry point to assess everyday norms and habits. In addition, through locating the 3Cs, broader issues that govern everyday norms were identified, for instance, the norms governed by systems. Therefore, the analysis did not replicate the 3Cs but offered comparably useful insights for this design research. Therefore, this approach is recommended for the examination of norms and rituals.

Further, two complex areas of waste management were established through the observation, which complements the social practice approach. First, despite the efforts of the farmers' market waste minimisation initiative, a composting plant that can process the large quantity of waste is yet to be located (section 5.3.1.1). Second, the observation of the student hall of residence displayed their

commitment to separating organic waste for the pig farm. However, this practice cannot be extended to commercial pig farms, due to the national biosecurity restrictions (section 4.3.3). These issues reflect Thorpe's (2010) study that a wide range of elements affect ideal behaviour for sustainability, including policies and rules. Identifying these issues is important for the human centred design process, but are beyond the range of Shove's 3Cs.

These instances demonstrated the applicability of a wider social practice approach, where disparate elements of practice are gathered as contributing factors. Carrying out a design analysis with the use of social practice approaches increase the scope to a wider area of design research. For instance, studies in social practice analyse a vast range of contexts including transport (Shove & Walker, 2010), domestic food waste (Evans, 2012), sustainability and consumption (Spaargaren, 2003). Therefore, the two approaches, Shove's 3Cs and social practice, used in tandem would possibly reveal useful insights from a wider design context.

7.3 SHOVE'S 3CS, SOCIAL PRACTICE AND THE DESIGN PROCESS

7.3.1 FRAMING THE DESIGN PROBLEM

Shove's 3Cs and social practice approaches proved suitable for this design research in the context of food waste. This research analysis was consistent with a number of studies suggesting these approaches are helpful in taking the focus away from individual behaviour to the examination of norms and practices in the social domain. This was particularly useful for this research which observed public food waste behaviour that required analysis beyond individual behaviour. Identifying elements of take-away coffee practice through social practice areas was an effective way of visualising the connected elements and multiple stakeholders that shape take-away coffee practice.

This analysis supports Ingram et alia's (2007) suggestion, that examining consumption and practice through a sociology approach may be beneficial for design. More specifically, this research found that for a broader context of design, Shove's 3Cs and social practice approaches are informative tools for the design process as illustrated in Figure 7.1.

Figure 7.1. Analysis of applicability of Shove's 3Cs to the design process

	OBSERVATION	ANALYSIS	FRAME DESIGN PROBLEM	IDEATION			CONCEPT EVALUATION		
			FORM BRIEF	DESIGN CONCEPT			DESIGN CONCEPT		
				1	2	3	1	2	3
SHOVE' S 3Cs		●	●				●	●	●

These approaches are effective in rapidly analysing fine nuances of observation data to frame design problems. The 3Cs and materials, meanings and conventions (Pantzar and Shove 2010) are effective in uncovering disparate elements of everyday norms, as suggested by Evans (2012). Consequently, the uncovering of disparate elements are helpful in making sense of wicked problems. In addition, Shove's 3Cs and social practice invite a non-linear investigation to explore the dynamics of everyday practice. This resonates with, and informs, the non-linear nature of the design thinking process (Brown, 2008; Cross, 2008). In the early phases of the design process, a vast range of related data and findings are required to construct a messy situation, or a wicked problem. Shove's 3Cs and the social practice approaches facilitated the observation analysis to effectively reveal fine nuances and disparate elements of the practice.

Further, the applicability of Shove's 3Cs and social practice approaches to design observation and analysis inform the framing of a design problem and the forming of a design brief. Identifying the disparate elements of everyday norms and rituals can be key to locating areas of priority for design intervention.

7.3.2 DESIGN IDEATION

The design ideation process highlighted that, beyond helping make sense of a wicked problem, Shove's 3Cs were less suited to the generation of design concepts. The limitation of application of Shove's 3Cs was identified during the ideation phase, when the attempts to ideate through the 3Cs tended to revert the design process back to re-examination and further interrogation of the wicked problem. Although the design process can benefit from periodically referring back to the re-examination of the rationale behind the design brief, endless sense-making is less constructive to design ideation. In other words, if the design process acts as a bridge between framing a design problem and offering a solution (Cross 2002), Shove's 3Cs and social practice were useful in framing a design problem. However, the 3Cs were less effective in bridging the gap between the problem and the solution.

This finding is valuable for my personal design education practice. At times, I encounter students who are immersed in design theory, which can hinder the design ideation as a consequence of lack of the direction provided by theoretical positions. This was, in fact, my own experience in this research. Therefore, this reinforces the importance of designers being familiar with various stages of the design process, and in gaining an understanding that some approaches are useful only for some stages of the process. This also reaffirms the importance of designers being flexible in their approaches throughout the design process.

This research endorses Buchanan's (1998) assertions about the non-prescriptive nature of the design process, and that each problem needs to be explored through a unique path. On the other hand, this research draws attention to the limitation of these approaches for the design ideation phase.

7.3.3 DESIGN EVALUATION AND REFINEMENT

Shove's 3Cs and social practice were valuable approaches to evaluate and rationalise design concepts. Evaluation of the design concepts through Shove's 3Cs and the social practice approaches suggested

the potential avenues for a wider application of these approaches to system design. The three design concepts generated in this research would benefit from a wider systems design to prompt greater transitions in the current landscape of food waste. Analysis of practice through materials, meanings and conventions could inform systems design. Future research on the applicability of Shove's 3Cs and social practice in systems design in the context of food waste may be useful.

7.4 PLURALISTIC APPROACH

The evaluation of the design process throughout this research highlights that a vast range of methods, frameworks and approaches were valuable throughout the design process. This reflects the recommended pluralistic approach to design for sustainable behaviour discussed in section 2.2.2 by a number of authors (Chapman, 2009; Fletcher, 2007; Lilley, 2005; Thorpe, 2007). This section evaluates various approaches and methods applied during this research, and how they contributed to the design process as illustrated in Figure 7.2.

7.4.1 WASTE AUDIT

In this research, a waste audit was a key method that helped to frame a design problem and establish the area of priority. The quantifiable data from the audit identified that disposable coffee cups were one of the most problematic areas of the waste stream (section 5.3.1). Therefore, the data was instrumental in establishing an area of priority, which helped to frame a design problem. In addition, the waste audit was also key to determining the area of practice, which contributed negatively to the waste stream. This was a significant finding that assisted in carrying out the subsequent analysis of take-away coffee practices through Shove's 3Cs and social practice. Therefore, waste audits are a valuable methodology to be undertaken at the onset of a project where appropriate. These findings reveal that engaging in methods that generate both quantifiable and qualitative data were helpful in revealing the rich contextual information that contributed to the framing of the design problem.

Figure 7.2 Analysis of application of design for sustainability approaches to the design process

	OBSERVATION	ANALYSIS	FRAME DESIGN PROBLEM FORM BRIEF	IDEATION DESIGN CONCEPT			CONCEPT EVALUATION DESIGN CONCEPT		
				1	2	3	1	2	3
SHOVE' S 3CS		●	●				●	●	●
SOCIAL PRACTICE APPROACH		●	●				●	●	●
IDEO OBSERVATION METHODS		●	●				●	●	●
WASTE AUDIT	●	●	●						
CHAPMAN'S EMOTIONAL DURABILITY					●			●	
THE PRODUCT LIFE CYCLE	●	●	●	●	●	●	●	●	●
DESIGN FOR DISSASSEMBLY				●	●				
ELIMINATE MONSTROUS HYBRIDS				●					
DESIGN IDEATION TOOLS				●	●	●	●	●	●
DE-MATERIALISATION				●					

7.4.2 THE PRODUCT LIFECYCLE

Reflecting on the implications of each phase of the life cycle—for example, the end of life in the local context, such as composting and recycling, was helpful in making decisions throughout the design process. This finding was consistent with Bhamra and Lofthouse's (2007) suggestion about design for sustainability practice.

This research also applied three useful strategies with respect to the product life cycle:

- a) simplifying the monstrous hybrid materials (Braungardt et al., 2009);
- b) dematerialisation (Shedroff, 2009); and
- c) design for disassembly (Shedroff, 2009).

These strategies were useful in refining design concepts in chapter 6 to ensure a more sustainable product outcome. Therefore, these practical strategies are most useful during the design conceptualisation phase and in the evaluation of a product. The nature of these strategies requires a product in question to be applied. Therefore, these strategies could not be applied until the ideation and refinement phases in order to evaluate the effectiveness of the design concepts.

7.4.3 CHAPMAN'S EMOTIONAL DURABILITY

In the design concept described in section 6.6.5.3, the emotional durability (Chapman, 2008) framework was applied to explore ways of ensuring longevity in the use phase through design. This framework could be practically applied to the design ideation phase. The framework was useful in suggesting areas such as material choices, that could embody narratives to designed artefacts to encourage users' emotional attachment to products.

7.4.4 DESIGN IDEATION TOOLS

The design ideation phase reinforced the usefulness of more conventional design tools. First, ideation drawings, which Cross (2008) explains as a critical reflective dialogue through sketching, assisted in problem clarification in the ideation phase. Cross (2008) also argues that during the design ideation process, there is often a cognitive leap which can be in the form of combination, mutation, or analogy. It is evident in the design sketches, that the ideation phase was also often aided by use of analogy and combination. This is illustrated in figure 7.3, where an analogy is made with the comment “a cup washer like the device that cools glasses at a bar”. Similarly, the disposable cup re-design concept shows a use of mutation during the design ideation to use existing manufacturing method for cups to mutate into a lid form.

Although this research did not intentionally apply the ideation methods discussed in Ideo Method Cards (Ideo 2003), on hindsight, those suggested in the Try section of Ideo Method Cards reflect the strategies applied during the design ideation phase of this research. In particular, Quick and Dirty Proto-typing (Ideo 2003) resonated with the process of mocking up three dimensional sketch models to reflect on the design concepts, and scenarios helped to generate a possible context for the use for design concepts.

Figure 7.3 Example of analogy during ideation

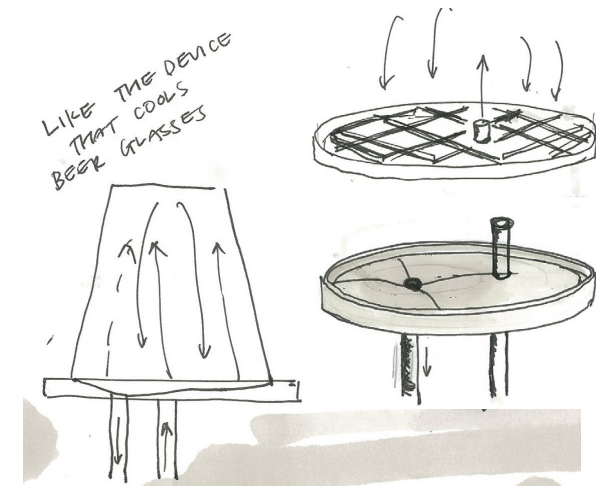

7.5 LIMITATIONS

A limitation of this research is that the three design concepts were not developed to prototypes that were tested at the farmers' market. Developing prototypes and testing the users of these concepts would allow for a evaluation of the effectiveness of the concepts. This may, in turn, present further evidence of the applicability of design for sustainability theories to design practice.

The methods used in the observations at the farmers' market were those that allowed for the discrete observation of normal practices in waste separation. The limited informal interviews that were carried out during the rapid ethnography stage were useful in capturing candid responses about the waste systems. Further research in this area may benefit from the Go-Along ethnography methodology (Evans, 2012), where interviews and observations are made while the researcher accompanies participants as they go about their activities. This methodology may be useful to gain greater understanding about people's perceptions, understandings and attitudes towards food waste and for a wider design application.

In response to Shove's investigation of resource consumption through the 3Cs, this research sought to examine the applicability of the 3Cs to a wider sustainability context. This research analysis is limited to the context of public food waste. This approach may benefit from further examination of the application of the approaches to other sustainability areas and to wider design problems.

CHAPTER EIGHT: CONCLUSION

8.1 CONCLUSIONS

Design for sustainable behaviour in a food waste context brought to attention the complex nature of generating design interventions for this area. A number of methodologies and approaches proved useful during this research. Shove's 3Cs and social practice approaches complemented human centred design strategies to uncover the connected elements that govern the landscape of food waste. In addition, a packaging audit helped assess ways to improve the waste stream while a waste audit was valuable to quantify the actual waste. The quantified data was instrumental in locating areas of priority for waste minimisation. Applying these approaches in conjunction with each other led to a more nuanced analysis of food waste within the design process.

This research also identified that Shove's 3Cs and social practice approaches are complementary to a human centred design process. Shove's 3Cs act as an effective entry point to a social practice approach, which is valuable knowledge in analysing further interconnected elements that govern everyday practice to inform design analysis. These approaches examine dynamics of disparate elements of everyday practice through a non-linear process, which reflects the non-linear nature of the design process. Consequently, these approaches combined, provide rich analysis to help make sense of wicked problems in order to frame design problems and form design briefs.

The evaluation of the design process carried out in this research indicates the importance of a pluralistic approach for design for sustainable behaviour. As a result, this research led to generating design concepts that utilised three ways for enabling sustainable behaviour: eliminating barriers to ideal behaviour, designing to prolong use phase of a product, and supporting the demand for the 3Cs with a more sustainable alternative. The design process also revealed that emotional durability was an effective framework to consider ways of designing products to prompt users' emotional attachment. Accordingly, designers could benefit from being familiar with various frameworks and approaches when designing for sustainability. Depending on the design brief and context, appropriate frameworks and approaches could be made use of to both inspire and evaluate the effectiveness of design concepts.

However, the pluralistic approach would be more effective when carried out with an understanding of when the approaches are suitable during the design process. This research, therefore, was of benefit in an investigation into how some of these approaches were applicable to a design process. In brief, this research identified that Shove's 3Cs, the social practice approach and waste audit were useful for design analysis and in the framing of problems. However they were limited in application during the design ideation phase. In contrast, approaches such as emotional durability, and dematerialisation may be more suitable after the forming of the design brief. Finally, considering the life cycle of a product was a useful tool throughout the design process, and conventional ideation tools, such as sketching and prototyping, cannot be overlooked as important parts of design ideation during the design for sustainability process. It is the uncovering of the strengths and limitations of the design for sustainable behaviour frameworks and approaches in application that I believe contributes to the intellectual growth of this discipline.

8.2 RECOMMENDATION FOR FUTURE RESEARCH

Future research for the farmers' market waste minimisation could include the following:

- 1) Carry out life cycle analysis, where possible, to identify the environmental impact of the design interventions as well as the current practice;
- 2) Scope ways of applying similar design interventions to take-away coffee practices in surrounding cafes and other outdoor food consumption sites;
- 3) Expanding the waste minimisation initiative to consider Vendors' Waste and Take-Away Waste in addition to Public Spaces Waste (section 5.1.3) would lead to meaningful change in the waste stream.

This research identified that Shove's 3Cs and a social practice approach were useful in uncovering fine nuances and in making sense of wicked problems. However, the application of a social practice approach was limited to the strategy of uncovering materials, meanings and conventions. Further research into ways that Shove's 3Cs and wider social practice theory can be effectively integrated into design processes would

be beneficial. Identifying ways to seamlessly integrate these approaches into design would better inform the complex context of design for sustainability and wider design innovation.

Considering behaviour during the use phase of the product life cycle through emotional durability was effective for designing products to prompt users' emotional attachment. Future research to identify effective ways that designers can contribute to a more sustainable use phase, including prolonging the use phase, would be valuable for design for sustainability.

The design of the re-use cup washer discussed in section 6.6 was purposefully terminated at the sketch concept stage to prioritise the assessment of the applicability of the design for sustainability frameworks. Further refinement of this product in computer aided software and physical prototyping may provide a platform to assess the applicability of product-led behavior interventions discussed in section 2.3.

REFERENCES

- Abrahamse, W., Steg, L., Vlek, C., & Rothengatter, T. (2005). A review of intervention studies aimed at household energy conservation. *Journal of Environmental Psychology*, 25(3), 273-291.
- Abrahamse, W., Steg, L., Vlek, C., & Rothengatter, T. (2007). The effect of tailored information, goal setting and tailored feedback of household energy use, energy-related behaviors and behavioral antecedents. *Journal of Environmental Psychology*, 27, 265-275.
- Ajzen, I., & Fishbein, M. (1977). Attitude-Behavior Relations - Theoretical-Analysis and Review of Empirical-Research. *Psychological Bulletin*, 84(5), 888-918.
- Bakker, C., Wever, R., Teoh, C., & De Clercq, S. (2010). Designing Cradle-to-Cradle Products: A Reality Check. *International Journal of Sustainable Engineering*, 3(1), 2-8.
- Bhamra, T., & Lofthouse, M. (2007). *Design for sustainability, A practical Approach*. Hampshire: Gower Publishing
- Bhamra, T., Lilley, D., & Tang, T. (2011). Design for Sustainable Behaviour: Using Products to Change Consumer Behaviour Design for Sustainable Behaviour: Using Products to Change Consumer Behaviour. *The Design Journal*, 14(4), 427-445.
- Braungart, M., McDonough, W., & Bollinger, A. (2007). Cradle-to-Cradle Design: Creating Healthy Emissions - a Strategy for Eco-Effective Product and System Design. *Journal of Cleaner Production*, 15(1337-1348).
- Breslin, M. & Buchannan, R. (2007). On the case study method of research and teaching in design. *Design Issues*, 24(1), 36-40.
- Brown, T. (2008). Design Thinking. *Harvard Business Review*, June, 1-10.
- Buchanan, R. (199). Wicked Problems in Design Thinking. *Design Issues*, 8(2), 5-21.
- Buchanan, R. (2001). Children of the Moving Present: The Ecology of Culture and the Search for Causes in Design. *Design Issues*, 17(1), 67-84.

- Burdick, A. (2003). Design as research. In B. Laurel (Ed.), *Design Research, Methods and Perspectives* (pp. 82). Cambridge: The MIT Press.
- Carrigan, M., & Szmigin, I. (2006). "Mothers of invention": Maternal empowerment and convenience consumption. *European Journal of Marketing*, 40(9/10), 1122-1142.
- Chapman, J. (2009). Design for (Emotional) Durability. *Design Issues*, 25(4), 29-35.
- Clune, S. (2010). Design and Behavioral Change. *Journal of Design Strategies*, 4(1), 68 - 75.
- Cross, N. (2006). *Designerly ways of knowing*. London: Springer Overlag.
- Electrolux. (2012, September 18 2012). Electrolux Design Lab Finalists Present Concepts that Stimulate the Senses. Retrieved October 23 2012
- Elkington, J. (1998). Partnerships from Cannibals with Forks: The triple bottom line of 21-Century Business. *Environmental Quality Management*, 8(1), 37-51.
- Evans, D. (2012). Beyond the Throwaway Society: Ordinary Domestic Practice and a Sociological Approach to Household Food waste. *Sociology*, 46(1), 41-56.
- Fletcher, K. (2007). Clothes that Connect. In J. Chapman (Ed.), *Designers, Visionaries and other stories: A Collection of Sustainable Design Essays* (pp. 118-132). London: Earth Scan.
- Friedman, K. (2003). Theory construction in design research: criteria: approaches, and methods. *Design Studies*, 24, 507-522.
- Froehlich, J., Findlate, L., & Landay, J. (2010). The design of eco-feedback technology. Conference on Human Factors in Computing Systems.
- Fulton Suri, J. (2005). *Thoughtless Acts?* San Fransisco: Chrobical Books.

- Gibson, E. (2011). The great coffee cup recycling challenge. Retrieved 09 October 2012, from Fairfax NZ News: <http://www.stuff.co.nz/business/industries/6200628/The-great-coffee-cup-recycling-challenge>
- Godfray, H., Crute, I., Haddad, L., Lawrence, D., Muir, J., Nisbett, N., Pretty, J., Sherman, R., Toulmin, C., & Whiteley, R. (2010). The future of the global food system. *The Royal Society*, 365, 2769-2777.
- Gustavsson, J., Cederberg, C., & Sonesson, U. (2011). Global Food Loss and food waste: Extent causes and prevention Paper presented at the international congress Save Food! Interpack, Düsseldorf, Germany
- Hargreaves, T. (2011). Practice-ing behaviour change: Applying social practice theory to pro-environmental behaviour change. *Journal of Consumer Culture*, 11(1), 79-99.
- Howard, J. (2004). Toward Participatory Ecological Design of Technological Systems. *Design Issues*, 20(3), 40-53.
- Ideo. (2003). *Ideo Method Cards: 51 Ways to Inspire Design*. Palo Alto: Ideo.
- Ingram, J., Shove, E., & Watson, M. (2007). Products and practices: Selected concepts from science and technology studies and from social theories of consumption and practice. *Design Issues*, 23(2), 3-16.
- Jelsma, J. & Knot, M. (2002). Designing Environmentally Efficient Services; a "Script" Approach. *The Journal of Sustainable Product Design*, 0(2), 119-130.
- Kaskinen, T., Kuittinen, O., Neuvonen, A., & Mokka, R. (2009). Gatekeepers changing consumers' behaviour in energy consumption. *Future of the Consumer Society*.
- Kolko, J. (2009). Abductive Thinking and Sensemaking: The drivers of Design synthesis. *Design Issues*, 26(1), 15-28.
- Lacey, E. (2009). Contemporary Ceramic Design for Meaningful interaction and emotional durability: a case study. *International journal of Design*, 3(2), 87-92.
- Lilley, D. (2009). Design for sustainable behaviour: strategies and perceptions. *Design Studies*, 30, 704-729.

- Lilley, D., Bhamra T., & Lofthouse., V. (2006). Towards Sustainable Use: An Exploration of Designing for Behavioural Change. DeSForm 2006: European Workshop on Design and Semantics of Form and Movement,, 84-95.
- Lilley, D., Lofthouse, V., & Bhamra, T. (2005). Towards instinctive sustainable product use. Paper presented at the Sustainability Creating the Culture.
- Lockery, S. (2011). The Ecocraze, a Case Study: Negotiating a Greener Product Design Landscape. Design Principles and Practices: An International Journal, 5(4), 41-62.
- Lockton, D., Harrison, D., & Stanton, N. (2008). Making the user more efficient: design for sustainable behaviour International Journal of Sustainable Engineering, 1(1), 3-8.
- Lovell, S., & Kemp, K. (2011). Dieter Rams: As little design as possible Phaidon.
- Lupton, E., & Abbott Miller, J. (1992). The bathroom, the kitchen, and the aesthetics of waste : a process of elimination. MIT List Visual Arts Center. 74, 71.
- McDonough, W., & Braungart, M. (2009). Cradle to Cradle: Remaking the way we make things. London: Vintage.
- McKenzie-Mohr. D. (2000). Promoting Sustainable Behavior: An Introduction to Community-Based Social Marketing. Journal of Social Issues, 56(3), 543-554.
- Mobley, C., Vagias, W., & De Ward, S. (2010). Exploring Additional Determinants of Environmentally Responsible Behavior. The Influence of Environmental Literature and Environmental Attitudes. Environment and Behaviour, 42(4), 420-447.
- Nahman, A., de Lange, W., Oelofse, S., & Godfrey, L. (2012). The cost of household food waste in South Africa. Waste Management, 32, 2147-2153.
- Nam, T., & Kim, C. (2011). Design by tangible stories: Enriching interactive everyday products with ludic value. International journal of Design 5(1), 85-98.

- Pantzar, M., & Shove, E. (2010). Understanding innovation in practice: a discussion of the production and re-production of Nordic Walking. *Technology Analysis & Strategic Management*, 22(4), 447-461.
- Papanek, V. (1971). *Design for the Real World: Human Ecology and Social Change*. Chicago: Academy Chicago Publishers
- Parfitt, J., Barthel, M., & Macnaughton, S. (2010). Review Food waste within food supply chains: quantification and potential for change to 2050. *The Royal Society*, 365, 3065-3081.
- Reckwitz, A. (2002a). The Status of the "Material" in theories of culture. From "social structure" to "Artefacts". *Journal for the Theory of Social Behaviour*, 32(2), 195.
- Reckwitz, A. (2002b). Toward a Theory of Social Practices A development in Culturalis Theorising. *European Journal of Social Theory*, 5(2), 243 - 263.
- Ropke, I. (2009). Theories of practice - New inspiration for ecological economic studies on consumption. *Ecological Economics*, 68(10), 2490-2497.
- Rossi, M., Charon, R., Wing, G., & Ewell, J.(2006). Design for the next generation. *Journal of Industrial Ecology*, 10(4), 193-210.
- Shedroff, N. (2009). *Design is the Problem: The future of design must be sustainable*. New York: Rosenfeld Media LLC.
- Sherwin, C., Bhamra, T., & Evans, S. (1998). The 'eco-kitchen' project – using eco-design to innovate. *The Journal of Sustainable Product Design*(7), 51-57.
- Shove, E. (2003a). *Comfort, Cleanliness and convenience: The social organisation of normality*. Oxford: Berg Publishers.
- Shove, E. (2003b). Converging Conventions of Comfort Cleanliness and Convenience. *Journal of Consumer Policy*(26), 395-418.

Shove, E., & Pantzar, M. (2005). Consumers, Producers and Practices Understanding the invention and reinvention of Nordic Walking. *Journal of Consumer Culture*, 5(1), 43-64.

Shove, E. & Walker, G. (2010). Governing transitions in the sustainability of everyday life. *Research Policy*, 39, 416-476.

Spaargaren, G. (2003). Sustainable consumption: A theoretical and environmental policy perspective. *Society & Natural Resources*, 16(8), 687-701.

Staats, H., Wit, A., & Midden, C. (1996). Communicating the Greenhouse Effect to the Public: Evaluation of a Mass Media Campaign from a Social Dilemma Perspective. *Journal of Environmental Management* (45), 189–203.

Stegall, N. (2006). Designing for Sustainability: A Philosophy for Ecologically Intentional Design. *Design Issues*, 22(2), 56-63.

Strengers, Y. (2008). Comfort expectations: the impact of demand management strategies in Australia. *Building Research and Information*, 36(4), 381 - 391.

Thorpe, A. (2010). Design's Role in Sustainable Consumption. *Design Issues*, 26(2).

Verganti, R. (2003). Design as a brokering of languages: Innovation Strategies in Italian Firms. *Design Management Review*, Boston, summer, 34-42.

Wade, A. (2009). Consumption and theories of practice. *Journal of Consumer Culture*, 5(2), 131-153.

IMAGE REFERENCE

Figure 6.7 : Keep Cup
<http://www.keepcup.com.au/>

APPENDIX ONE: IDEATION PROCESS WORK

CONCEPT IDEATION ONE: DISPOSABLE CUP REDESIGN

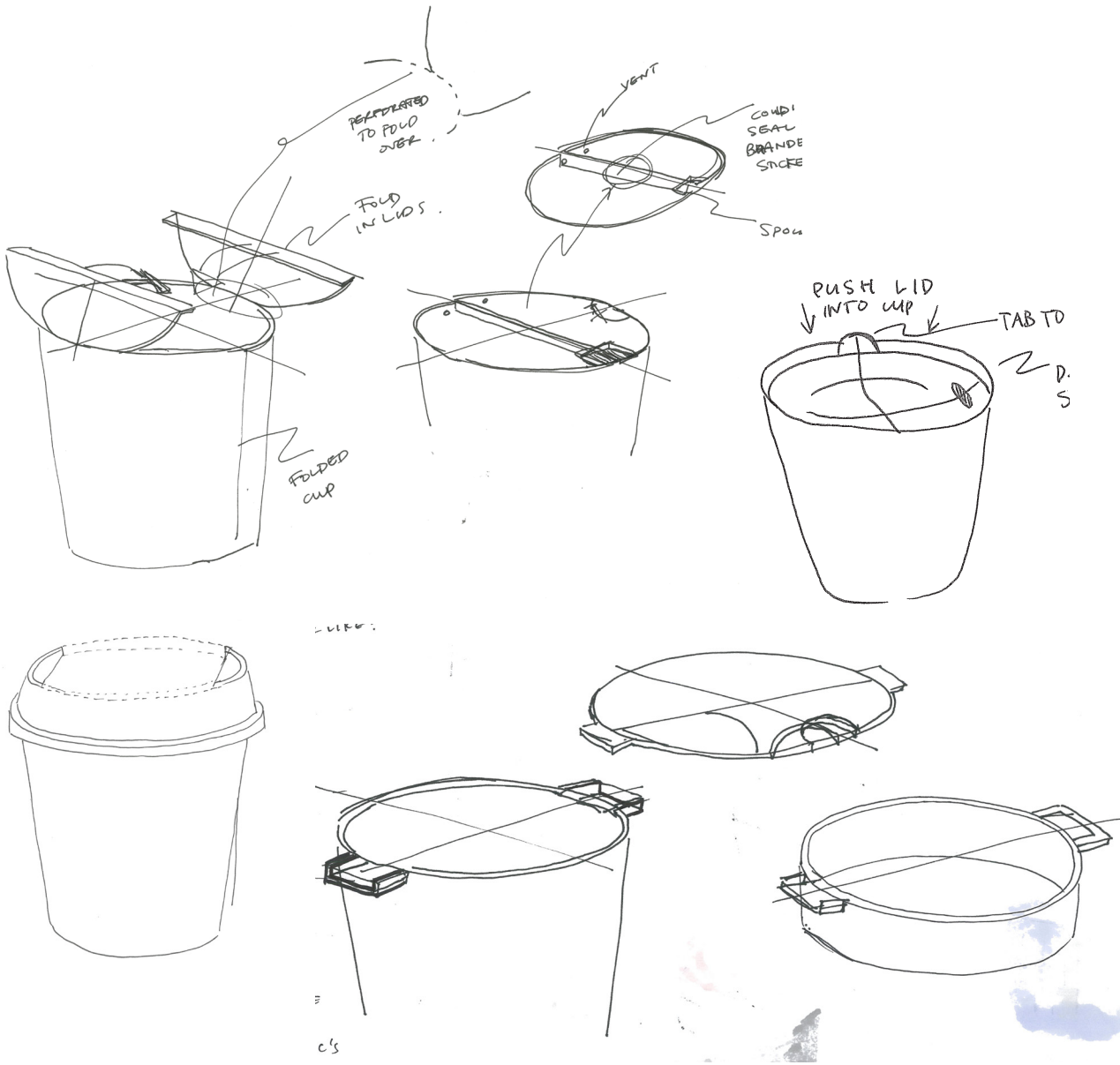

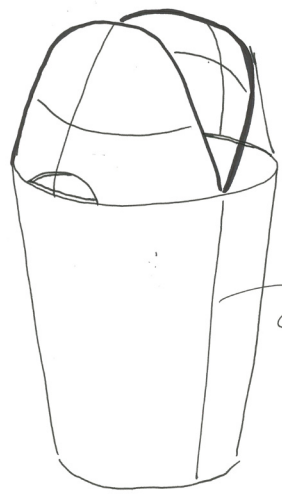

FOLDED PAPER CUP

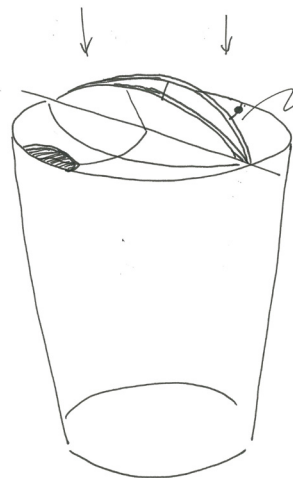

PRESS DOWN TO SEAL LID

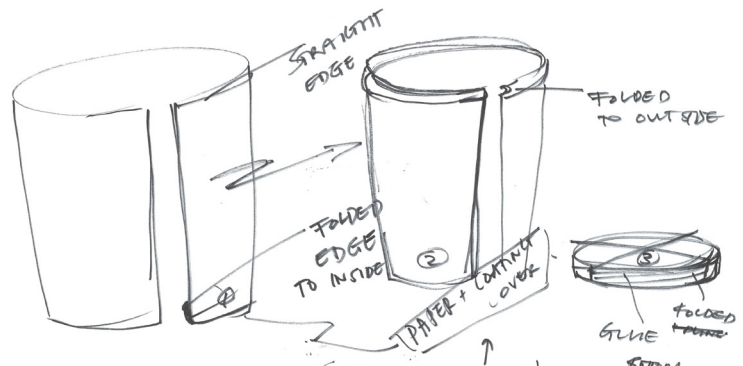

SKINNY EDGE

FOLDED EDGE TO INSIDE

FOLDED TO OUTSIDE

PAPER + CONTAINER COVER

FOLDED GLUE BOTTOM



PAPER ONLY : 2 PIECES



CHINA
↓
BLENKABLE
TAPS
CUPS

• COPPER
• STAINLESS
• CHINA

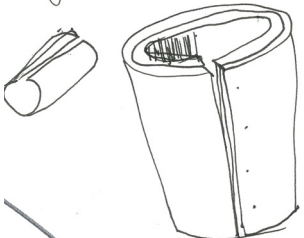

SURFACE MATERIALS

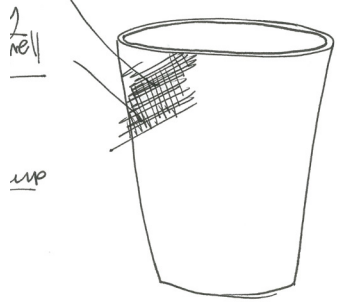

2
well
cup

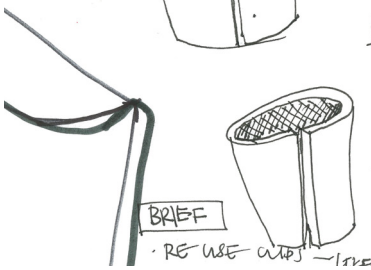

BRIEF

• RE-USE CUPS - 1 TIME

physically Aging well

WAGE FOR CUP

SURE MATE

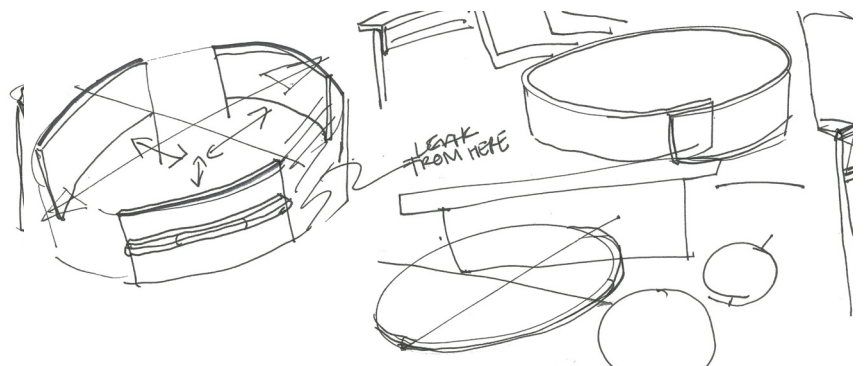
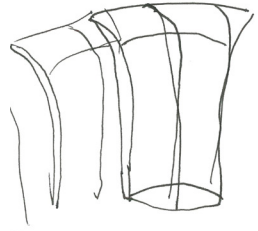

LEAK FROM HERE

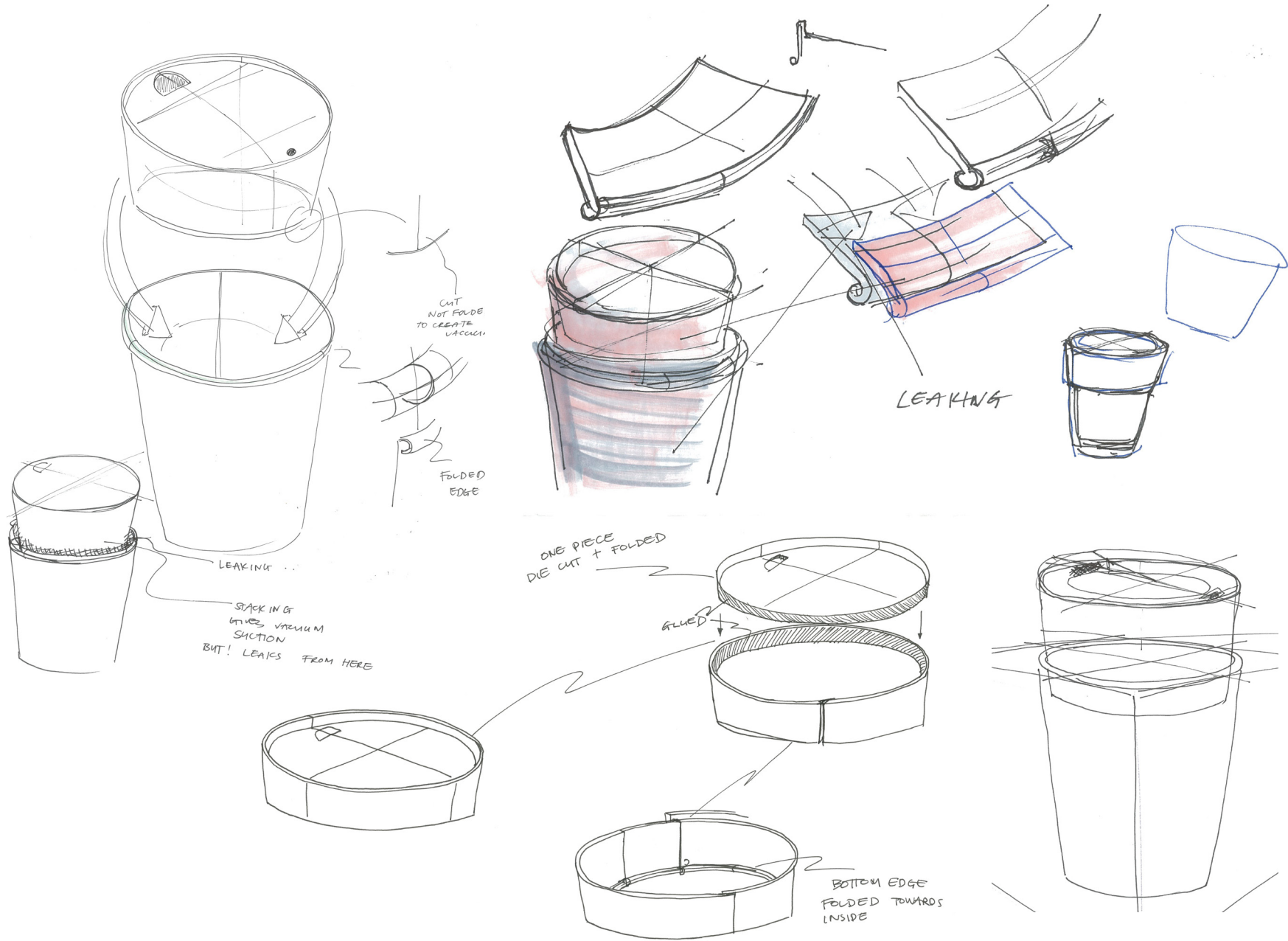

CONCEPT IDEATION TWO : RE-USABLE CUP REDESIGN

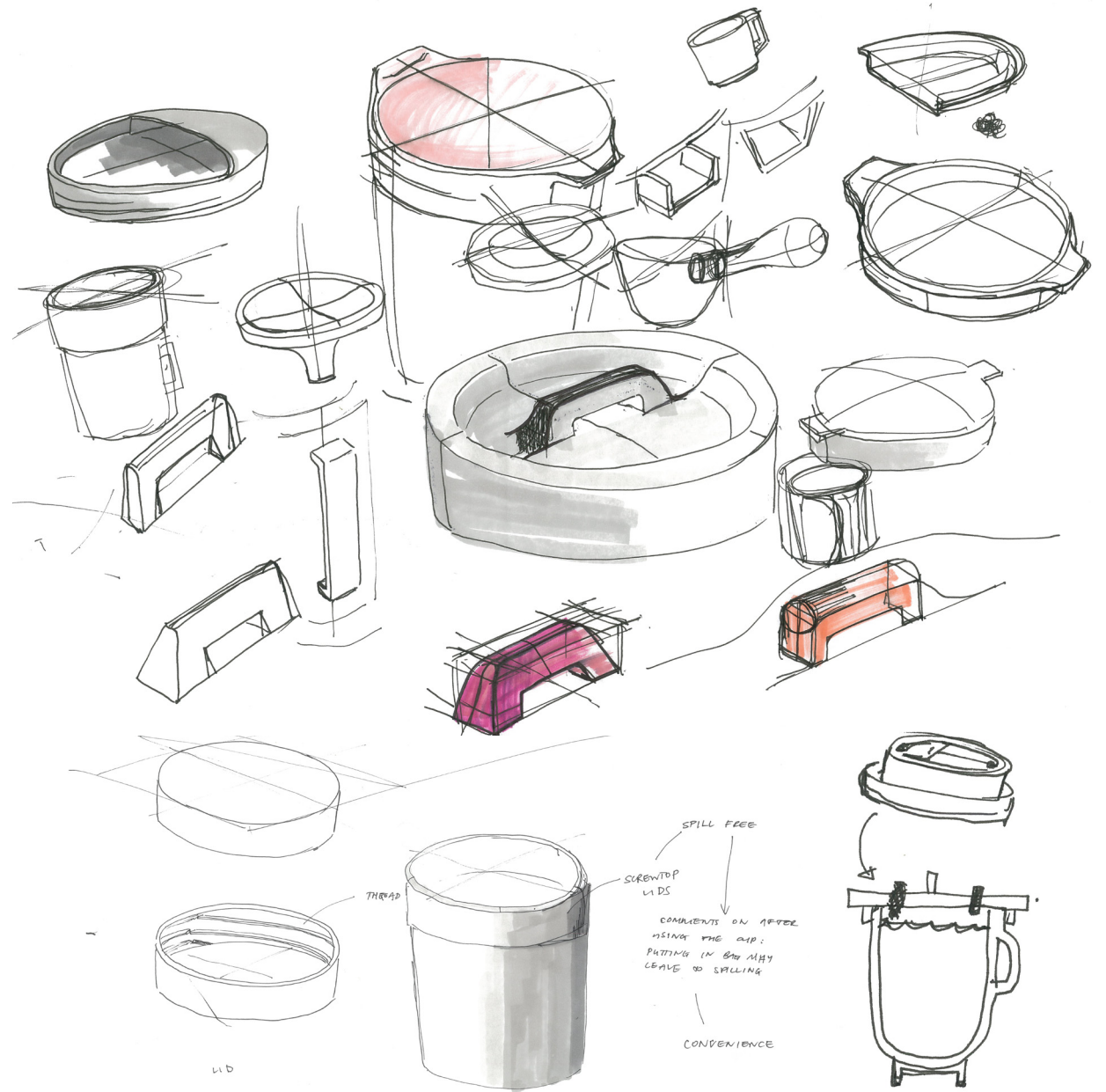

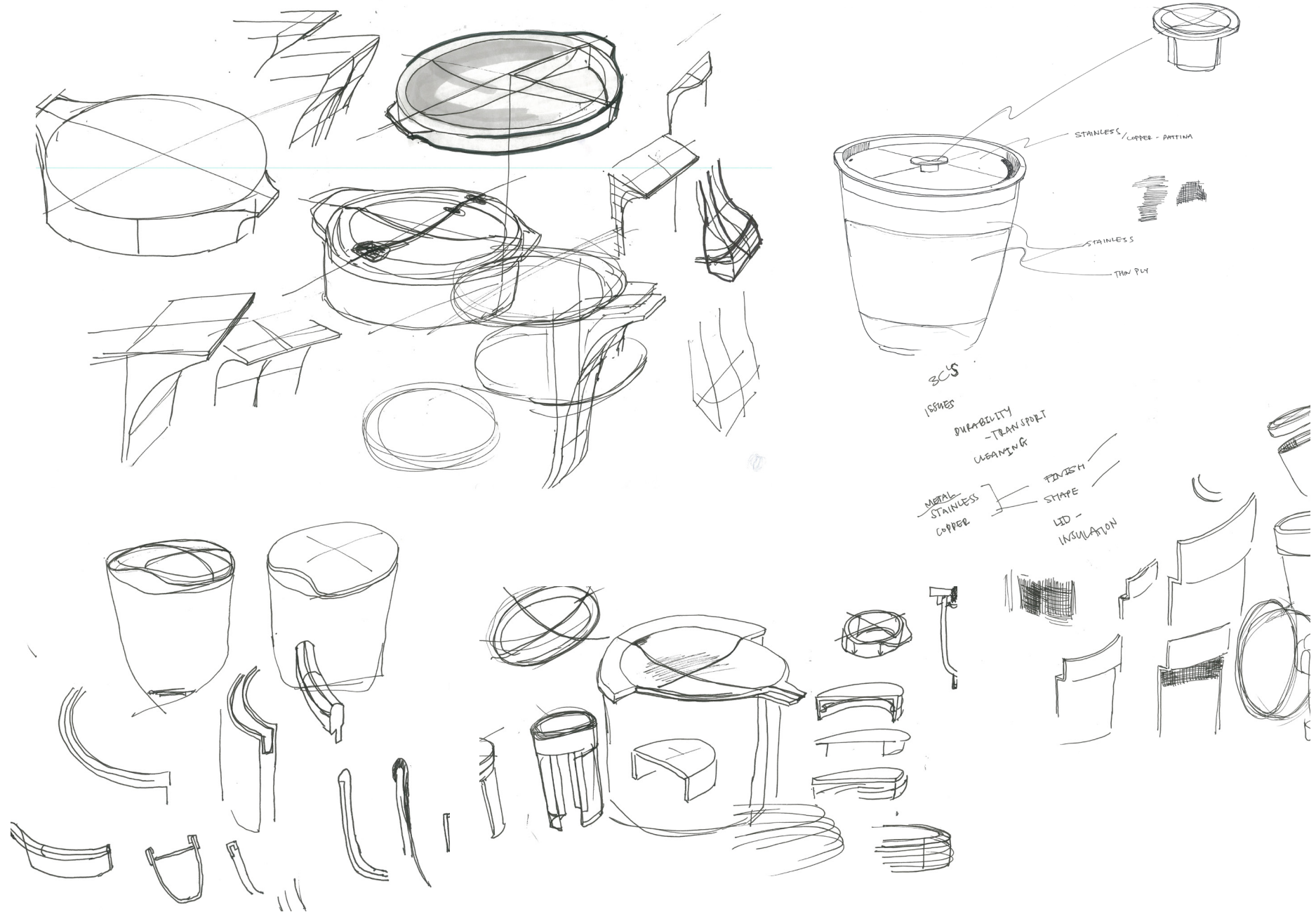

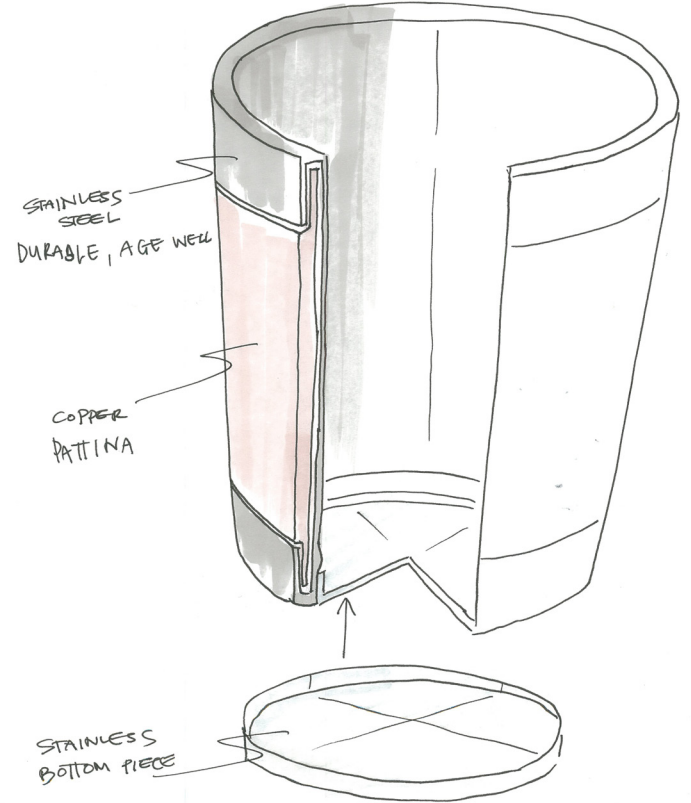
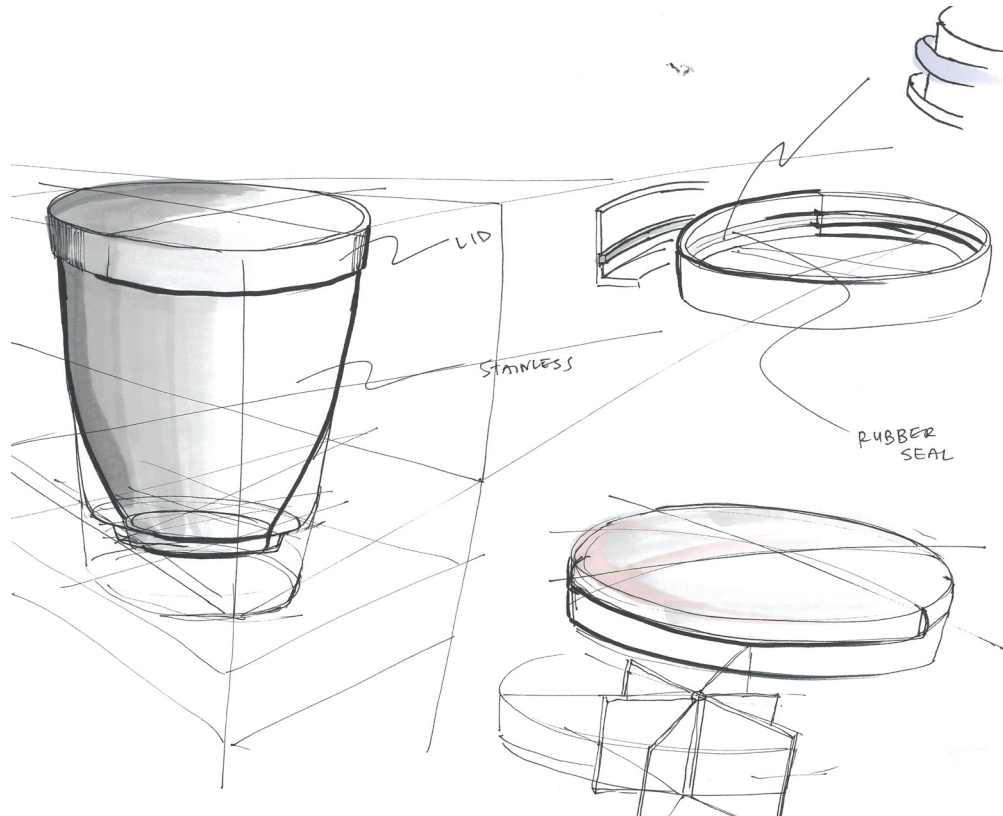
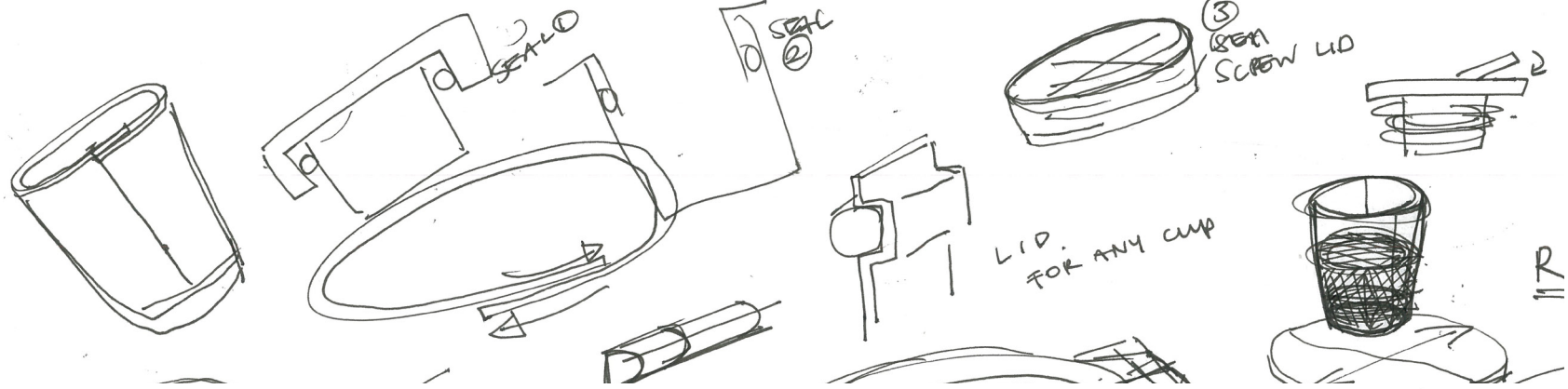

CONCEPT IDEATION THREE:
RE-USABLE CUP WASHER

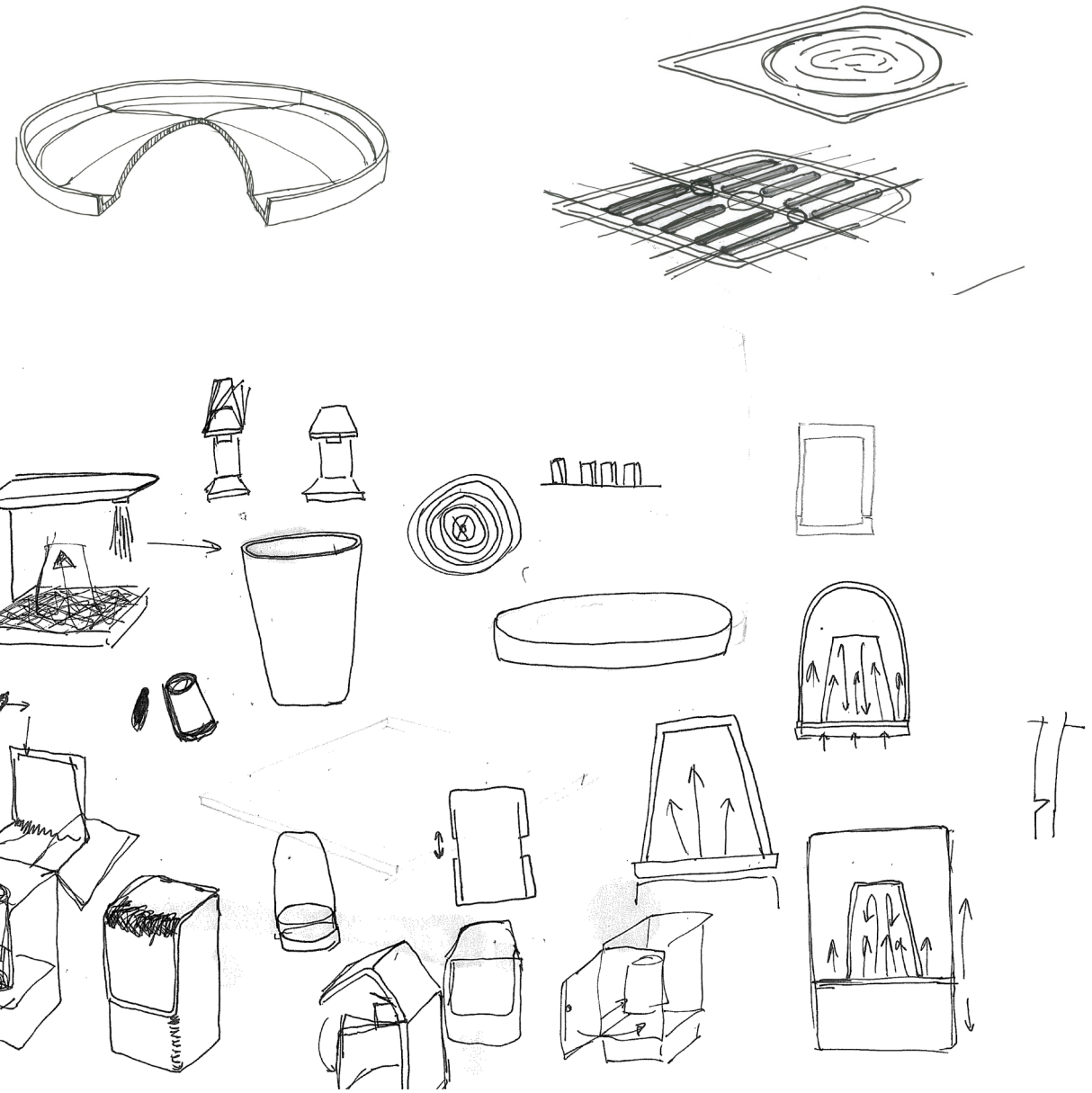

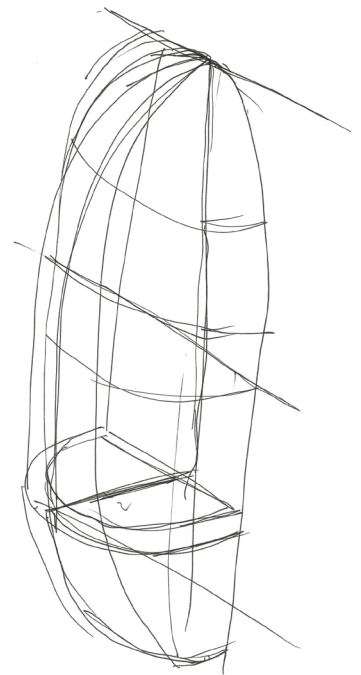
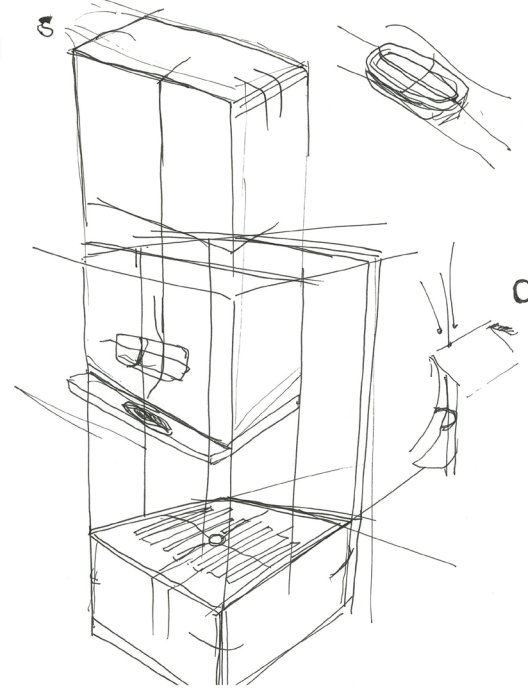
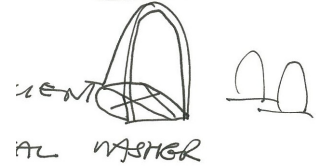
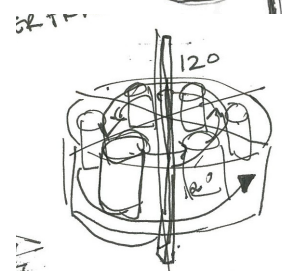
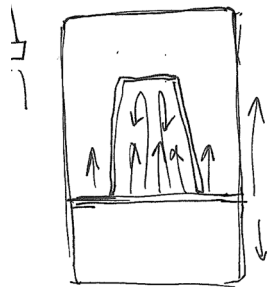
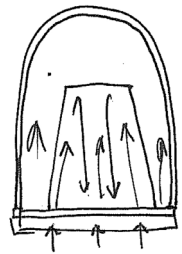
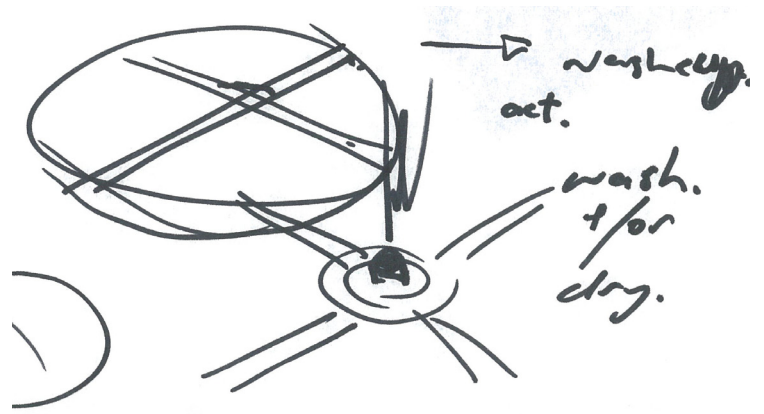
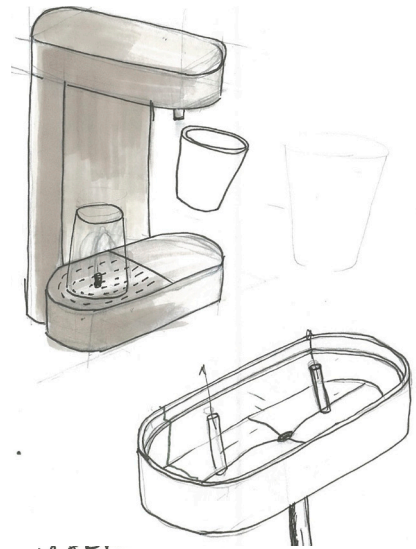
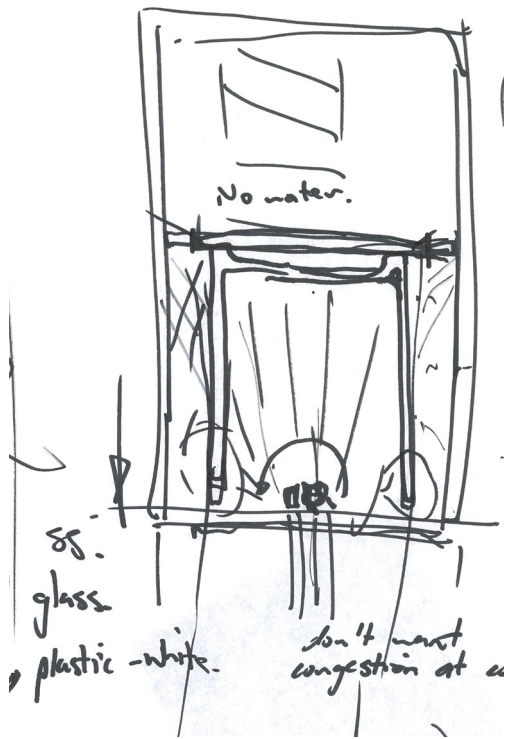

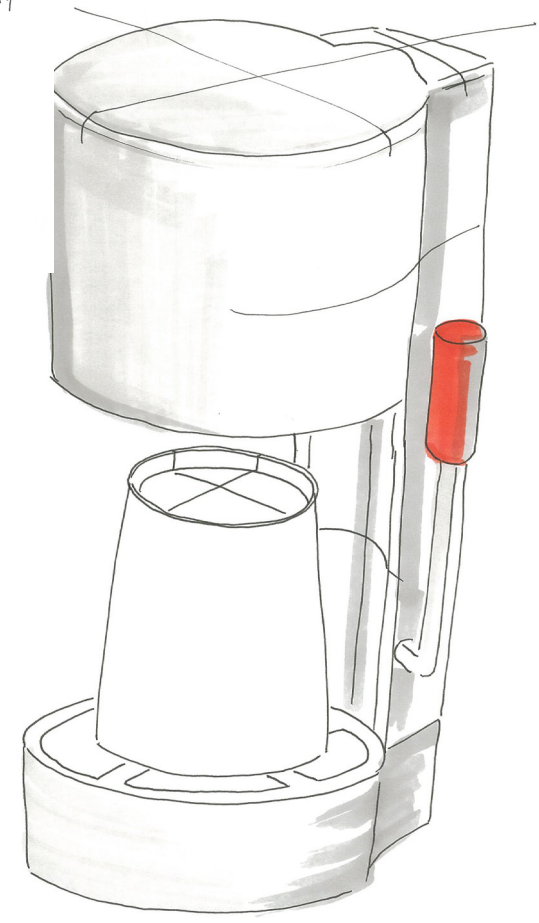
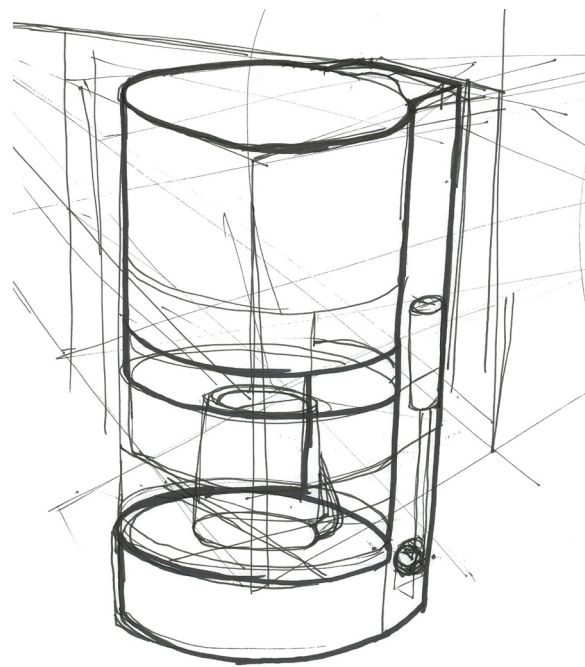
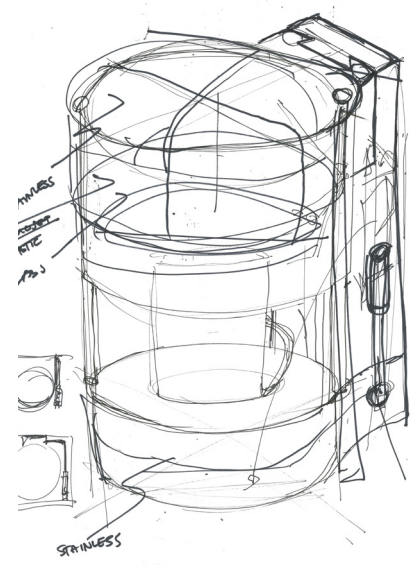
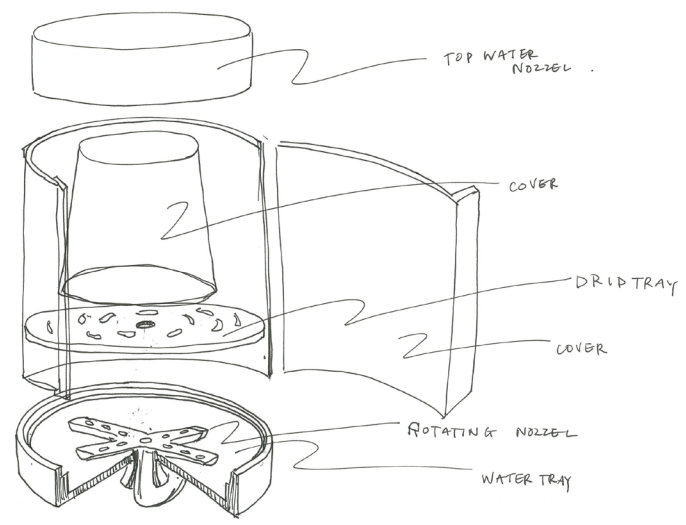

APPENDIX TWO: ETHICAL APPROVAL FORMS