

# Teaching and learning spatial thinking with young students: The use and influence of external representations

**Peta Spencer**

Bachelor of Education, Master of Education (Research)

**Faculty of Education and Arts**

Submitted in fulfilment of the requirements for the degree of  
Doctor of Philosophy

Graduate Research Office  
Australian Catholic University  
PO Box 968  
North Sydney NSW 2059

October 2017



## **Keywords**

external representations; gesture; mathematics; physical manipulatives; representations; scaffolding; sociocultural perspective; spatial orientation; spatial thinking; spatial visualisation; teaching and learning; virtual manipulatives

## Statement of Authorship and Sources

This thesis contains no material published elsewhere or extracted in whole or in part from a thesis by which I have qualified for or been awarded another degree or diploma.

No parts of this thesis have been submitted towards the award of any other degree or diploma in any other tertiary institution.

No other person's work has been used without due acknowledgement in the main text of the thesis.

All research procedures reported in the thesis received the approval of the relevant Ethics/Safety Committees (where required).

Charlotte Cottier (IPEd Accredited Editor) provided copyediting and proofreading services according to the guidelines laid out in the university-endorsed national "Guidelines for editing research theses".

Signature: \_\_\_\_\_

Date: \_\_\_\_\_

# Acknowledgements

The thesis has been a wonderful journey, which would not have been possible without the guidance and support of my supervisors, friends and family.

Firstly, I would like to express my sincere gratitude to my Principal Supervisor, Professor Elizabeth Warren, for her continuous support of my PhD study. I am grateful for your patience, motivation, and immense knowledge. Your timeless dedication has improved my writing and guided me through this learning journey over the past five years. Your professionalism for the work and genuine care for my well-being has made this whole process achievable. Thank you.

I also thank my second supervisor Associate Professor Vincent Geiger, for your support, advice and encouragement. It has been valuable to have a different perspective on ideas and concepts.

Jodie Miller, you not only provided me with sound advice about the whole PhD process, but were there when emotional support was needed. The emotional support received from you over the last year has enabled me to complete this journey.

To my mum and dad, Lyn and Barry, this whole process would not have been possible without you. Your unconditional love and support for my family and myself over the years has enabled me to accomplish great things. I hope I have made you proud.

To my husband, David, I am forever grateful for your encouragement, love and endless hours of proofreading. Without you and your support, this would not have been possible. I look forward to being able to spend more time with you and our children.

To my beautiful daughters, Lily, Piper and Scarlett, it has been amazing watching you grow and learn over the years. Thank you for the sacrifices you have made, the missed play dates, craft times and adventures. I look forward to being able to spend more time with you, doing the things we love. I love you with all my heart, and hope I inspire you to achieve and be all that you can be.



# Table of Contents

Keywords .....	i
Statement of Authorship and Sources.....	ii
Acknowledgements.....	iii
Table of Contents .....	v
List of Figures .....	x
List of Tables .....	xii
Abstract .....	xvi
List of Abbreviations .....	xviii
Glossary .....	xix
<b>CHAPTER 1: INTRODUCTION.....</b>	<b>1</b>
1.1 Chapter Overview.....	1
1.2 Background.....	2
1.3 Research Context.....	3
1.3.1 Mathematics learning and educationally disadvantaged students.....	4
1.4 Research Problem and Purpose .....	7
1.5 Aims and Research Questions .....	9
1.5.1 Research questions .....	9
1.6 Research Design .....	9
1.6.1 Epistemology.....	9
1.6.2 Theoretical perspective .....	10
1.6.3 Research methodology .....	10
1.6.4 Participants.....	10
1.6.5 Data collection strategies .....	10
1.7 Significance of Research .....	11
1.8 Thesis Outline.....	12
1.8.1 Chapter 1: Introduction .....	12
1.8.2 Chapter 2: Literature Review .....	12
1.8.3 Chapter 3: Research Design .....	12
1.8.4 Chapter 4: Findings – Spatial Thinking and Teaching.....	12
1.8.5 Chapter 5: Findings – Student Learning .....	13
1.8.6 Chapter 6: Discussion.....	13
1.8.7 Chapter 7: Conclusions and Recommendations.....	13
<b>CHAPTER 2: LITERATURE REVIEW.....</b>	<b>15</b>
2.1 Chapter Overview.....	15
2.2 Spatial Thinking .....	16
2.2.1 Defining spatial orientation and spatial visualisation .....	17
2.2.1.1 Spatial orientation .....	17
2.2.1.2 Spatial visualisation.....	18
2.2.2 Teaching spatial thinking .....	19
2.2.3 Van Hiele’s model and Piaget’s theory for developing spatial thinking.....	21
2.2.3.1 Phases of learning.....	22

2.2.3.2 Critique of Van Hiele’s model .....	23
2.3 Student Difficulties with Spatial Thinking .....	24
2.3.1 Student difficulties with representations .....	24
2.3.2 Student difficulties with mathematical language .....	27
2.4 Representations .....	28
2.4.1 Internal representations .....	28
2.4.2 External representations .....	29
2.4.3 Student learning involves transference between internal and external representations .....	30
2.4.4 Manipulatives .....	31
2.4.4.1 Physical manipulatives .....	31
2.4.4.2 Virtual manipulatives .....	32
2.4.4.3 Comparison of physical and virtual manipulatives .....	35
2.4.4.4 Concluding comments .....	36
2.5 Research Questions .....	36
2.6 Vygotsky’s Sociocultural Theory as a Theoretical Framework .....	37
2.6.1 Fundamental concepts in Vygotsky’s theory .....	38
2.6.1.1 Internalisation .....	38
2.6.1.2 Mediation .....	39
2.6.1.3 The Zone of Proximal Development (ZPD) .....	40
2.6.1.4 The interrelationship of thought and language .....	40
2.7 Application of Vygotsky’s Theoretical Framework .....	41
2.7.1 Scaffolding .....	41
2.7.1.1 Importance of language in scaffolding .....	42
2.7.1.2 Establishing a lens based in scaffolding .....	43
2.7.1.3 Choosing Anghileri’s hierarchy of scaffolding practices as a lens to examine scaffolding (amalgamated, linked, connected) .....	46
2.7.2 Using a commognitive approach as a lens to understand students’ learning .....	49
2.7.2.1 Mathematical words and learning .....	51
2.7.2.2 Visual mediators and learning .....	53
2.7.2.3 Endorsed narratives .....	56
2.7.2.4 Routines and learning .....	57
2.8 Research Questions Revisited .....	60
2.9 Chapter Review .....	61
<b>CHAPTER 3: RESEARCH DESIGN .....</b>	<b>63</b>
3.1 Chapter Overview .....	63
3.2 Research Design .....	64
3.2.1 Interpretative paradigm .....	65
3.2.2 Sociocultural theoretical perspective .....	66
3.3 Research Methodology .....	67
3.3.1 Case study methodology with quasi-experimental design .....	67
3.3.1.1 Case study methodology .....	67
3.3.1.2 Quasi-experimental design .....	68
3.4 Participants .....	68
3.4.1 Students .....	68
3.4.2 Researcher .....	69
3.5 Data Collection Strategies .....	69
3.5.1 Development of the spatial testing materials .....	71
3.5.2 Teaching experiments .....	71
3.5.2.1 Development of the teaching experiment lessons .....	72
3.6 Data Collection Procedures .....	76



3.7	Data Analysis.....	77
3.7.1	Quantitative data analysis.....	77
3.7.2	Qualitative data analysis.....	78
3.8	Trustworthiness .....	84
3.8.1	Establishing trustworthiness with the quantitative data .....	84
3.8.2	Establishing trustworthiness with the qualitative data .....	85
3.9	Ethical Considerations.....	86
3.10	Chapter Review .....	87
<b>CHAPTER 4: FINDINGS – SPATIAL THINKING AND TEACHING .....</b>		<b>89</b>
4.1	Chapter Overview.....	89
4.2	Influence of Physical Manipulatives and Virtual Manipulatives on Students’ Spatial Thinking.....	90
4.2.1	Background to data collection and analysis .....	90
4.2.2	Pre-test results .....	90
4.2.3	Post-test results.....	92
4.2.4	Paired t-test results (pre-test to post-test).....	94
4.2.5	Retention of understanding .....	96
4.2.6	Summary of analysis of influence of PM and VM on students’ spatial thinking .....	101
4.3	Influence of Representations on the Teaching of Spatial Concepts .....	102
4.3.1	Background to the data collection and analysis .....	102
4.3.2	Analysis of teacher’s scaffolding .....	103
4.3.2.1	Teacher scaffolding in the PM class lessons.....	104
4.3.2.2	Teacher scaffolding in the VM class lessons .....	118
4.3.3	Comparison of teacher scaffolding practices in the PM and VM lessons.....	143
4.3.4	Comparison of teacher’s mathematical words and visual mediators .....	147
4.3.4.1	Comparison of mathematical words.....	148
4.3.4.2	Comparison of visual mediators.....	149
4.4	Chapter Review .....	155
4.4.1	Influence of representations (PM and VM) on students’ spatial thinking .....	155
4.4.2	How the teaching (i.e., teacher scaffolding practices) changed from the PM class to the VM class.....	156
<b>CHAPTER 5: FINDINGS – STUDENT LEARNING.....</b>		<b>159</b>
5.1	Chapter Overview.....	159
5.2	Different Types of Communication Used by Students When Sharing Their Learning.....	159
5.2.1	Delineating the levels of sentence structure within mathematical word analysis .....	160
5.2.1.1	Limited use of language .....	161
5.2.1.2	Simple sentences and short phrases .....	161
5.2.1.3	Complex sentences (including the use of circumstances).....	163
5.2.1.4	Questioning .....	164
5.2.2	Delineating the types of gestures identified in the visual mediator analysis .....	164
5.2.2.1	Grounding (GE) or changing body positioning (BP) in relation to the physical materials.....	165
5.2.2.2	Pointing at objects (G1).....	166
5.2.2.3	Pointing to the object as a reference (G1a) .....	167
5.2.2.4	Iconic representation of the object (G2).....	168
5.2.2.5	The use of metaphoric gestures .....	170
5.2.2.6	Beat gesture .....	171
5.3	Analysis of Students’ Communication of Learning .....	172
5.3.1	Comparing PM and VM students’ communication of learning .....	172

5.3.1.1	Analysis of differences between PM and VM students' use of mathematical words.....	172
5.3.1.2	Analysis of differences between PM and VM students' use of visual mediators (gestures).....	176
5.3.1.3	Summary of PM and VM students' communication.....	180
5.3.2	Students' communication of learning and its influence on teaching .....	180
5.4	Chapter Review .....	182
5.4.1	Summary of student learning findings .....	182
<b>CHAPTER 6: DISCUSSION .....</b>		<b>185</b>
6.1	Chapter Overview.....	185
6.2	The Influences of Representations on Students' Learning.....	186
6.3	Changes in Teacher's Scaffolding in the PM and VM Classrooms .....	189
6.3.1	An overview of Anghileri's hierarchy of scaffolding practices.....	189
6.3.2	Scaffolding practices in the PM class .....	191
6.3.2.1	Adding to Anghileri's hierarchy of scaffolding practices.....	192
6.3.2.2	Comparing Anghileri and Van Hiele's theoretical frameworks and the findings from the PM class .....	195
6.3.2.3	A new theoretical framework for scaffolding students' spatial thinking with PM.....	196
6.3.3	Anghileri's theoretical framework and the VM classroom.....	198
6.4	Changes in Students' Learning in the VM Classroom .....	201
6.4.1	Student learning in the VM classroom.....	201
6.4.1.1	Changes in students' mathematical words examined through utterances ....	202
6.4.1.2	Changes in communication related to the use of visual mediators .....	205
6.4.1.3	The relationship between mathematical words and visual mediators .....	209
6.4.1.4	Changes in routines .....	211
6.4.2	Changes to the teacher–learner agreement.....	213
6.4.2.1	Changes to the teacher–learner agreement influenced by the use of iPad apps .....	213
6.4.2.2	Changes to the teacher–learner agreement influenced by peer scaffolding ..	215
6.4.2.3	Changes in the teacher's teaching .....	216
6.4.2.4	Implication of changes to the teacher–learner agreement for the teaching..	220
6.5	Chapter Review .....	220
<b>CHAPTER 7: CONCLUSIONS AND RECOMMENDATIONS.....</b>		<b>221</b>
7.1	Chapter Overview.....	221
7.2	Restating of the Research Purpose .....	221
7.3	Research Design .....	222
7.4	Research Questions Addressed.....	223
7.4.1	Research Question One .....	224
7.4.2	Research Question Two .....	226
7.4.3	Developing a theoretical framework for the teaching and learning of spatial concepts.....	228
7.5	Conclusions of the Study.....	231
7.5.1	Conclusion One .....	232
7.5.2	Conclusion Two .....	232
7.5.3	Conclusion Three .....	232
7.5.4	Conclusion Four .....	233
7.6	Implications of the Research .....	233
7.6.1	Implications for teaching and learning.....	234
7.6.2	Implications for research.....	235

7.7	Further Research Considerations.....	235
7.8	Limitations.....	236
7.9	Concluding Remarks .....	237
<b>REFERENCES.....</b>		<b>239</b>
<b>APPENDICES.....</b>		<b>271</b>
	Appendix A Spatial Orientation Test .....	271
	Appendix B Spatial Visualisation Test 1.....	276
	Appendix C Spatial Visualisation Test 2.....	281
	Appendix D Spatial Content Knowledge Test .....	286
	Appendix E Overview of Lessons and Testing Materials .....	296
	Appendix F Comprehensive Overview of Teaching Experiment Lessons.....	298
	Appendix G Brief Overview of Matched Lessons .....	305
	Appendix H Researcher’s Field Notes from the Teaching Experiment .....	306
	Appendix I Comparison of Scaffolding Practices for Lesson 3 in PM and VM Classes .....	309
	Appendix J Australian Catholic University Ethics Approval Letter .....	329
	Appendix K Brisbane Catholic Education Ethics Approval Letter.....	330
	Appendix L Information Letter to the Principal .....	331
	Appendix M Consent Form for the Principal .....	334
	Appendix N Information Letter to the Teacher .....	335
	Appendix O Consent Form for the Teacher .....	338
	Appendix P Information Letter to the Student .....	339
	Appendix Q Consent Form for the Student .....	342
	Appendix R Teacher’s and Students’ Frequency of Difference <i>Special Keywords</i> .....	343

# List of Figures

<i>Figure 1.1.</i> Overview of Chapter 1.....	1
<i>Figure 1.2.</i> PISA 2015 average mathematical literacy performance and differences over time (Thomson, De Bortoli, & Underwood, 2017, p. 167). .....	3
<i>Figure 1.3.</i> PISA 2015 average mathematical literacy performance and differences over time for Queensland (Thomson, De Bortoli, & Underwood, 2017, p. 174). .....	6
<i>Figure 2.1.</i> Overview of Chapter 2.....	16
<i>Figure 2.2.</i> Van de Pol, Volman, and Beishuizen’s (2010) conceptual model of essential elements of scaffolding. ....	44
<i>Figure 2.3.</i> Gradual Release of Responsibility Model (Pearson & Gallagher, 1983). ....	44
<i>Figure 2.4.</i> Anghileri’s hierarchy of scaffolding practices.....	47
<i>Figure 3.1.</i> Overview of Chapter 3.....	64
<i>Figure 3.2.</i> A comparison of lesson phases used in this study to Van Hiele’s (1986) Phases of Learning.....	73
<i>Figure 4.1.</i> Overview of Chapter 4.....	89
<i>Figure 4.2.</i> Summary of scaffolding practices applied to PM lessons. ....	118
<i>Figure 4.3.</i> Screenshots from the iPad app “P.O.V.” .....	131
<i>Figure 4.4.</i> Screenshot for the iPad app “Symmetry School”. ....	133
<i>Figure 4.5.</i> Screenshot of tasks required of students in the app “P.O.V.”.....	137
<i>Figure 4.6.</i> Examples of the three tasks and the “explore” function in the app “3D Objects and Nets” .....	139
<i>Figure 4.7.</i> Model of main teacher scaffolding levels implemented in each lesson phase.....	142
<i>Figure 4.8.</i> Comparison of totals of each scaffolding level (PM vs. VM). ....	145
<i>Figure 4.9.</i> Comparison of frequencies of each scaffolding practice in the PM and VM classes in the Enhance: Guided Application phase. ....	146
<i>Figure 4.10.</i> Summary of findings when comparing scaffolding practices for the two classes. ....	147
<i>Figure 4.11.</i> Comparison of overall frequencies of each gesture category in the PM and VM classes in Lesson 3. ....	149
<i>Figure 4.12.</i> Comparison of the frequencies of grounding gestures (GE) in the PM and VM classes according to phases. ....	150
<i>Figure 4.13.</i> Comparison of the frequencies of iconic gestures (G2) in the PM and VM classes according to phases. ....	151
<i>Figure 4.14.</i> Comparison of total frequencies of all gestures in each phase in Lesson 3.....	152
<i>Figure 4.15.</i> Comparison of gestures in the PM and VM classes in the Orientate phase.....	153
<i>Figure 4.16.</i> Comparison of gestures in the PM and VM classes in the Synthesise phase. ....	153
<i>Figure 4.17.</i> Summary of findings when comparing mathematical words and visual mediators for the two classes. ....	155
<i>Figure 5.1.</i> Overview of Chapter 5.....	159
<i>Figure 5.2.</i> PM students’ changes to body positioning (BP) (video data L3SO PM 1). ....	166
<i>Figure 5.3.</i> Examples of pointing gestures (G1).....	167

<i>Figure 5.4.</i> Example of pointing gestures (G1a) with appropriate language.....	168
<i>Figure 5.5.</i> Example of iconic gesture.....	169
<i>Figure 5.6.</i> Example of iconic gesture (G2) for “flip it over”.....	170
<i>Figure 5.7.</i> Frequency of use of the different sentence structures across Lesson 3 (PM and VM classes).....	173
<i>Figure 6.1.</i> Overview of Chapter 6.....	186
<i>Figure 6.2.</i> Anghileri’s (2006) hierarchy of scaffolding practices.....	190
<i>Figure 6.3.</i> The findings of the scaffolding in the PM class.....	191
<i>Figure 6.4.</i> The hierarchical structure within Anghileri’s Level 2 scaffolding structure.....	192
<i>Figure 6.5.</i> A section of scaffolding practices in the Enhance: Explicit Modelling phase highlighting simultaneously occurring scaffolds and subsequent higher-level scaffolds.....	194
<i>Figure 6.6.</i> A new model of extending Anghileri’s scaffolding practices to include Van Hiele’s Phases of Learning when using PM.....	197
<i>Figure 6.7.</i> The teacher–learner agreement within the PM class.....	198
<i>Figure 6.8.</i> The findings of scaffolding practices implemented in the VM class.....	199
<i>Figure 6.9.</i> Comparing the scaffolding in the Orientate phase of the PM and VM classes.....	200
<i>Figure 6.10.</i> The teacher–learner agreement within the VM class.....	219
<i>Figure 7.1.</i> Overview of Chapter 7.....	221
<i>Figure 7.2.</i> Interaction between teacher, student and physical/virtual manipulatives.....	229

## List of Tables

Table 2.1 <i>Five Levels of Thought Together with a Description of Students' Actions at Each Level</i> .....	21
Table 3.1 <i>Theoretical Framework of the Study</i> .....	65
Table 3.2 <i>Timeline and Stages of Data Collection</i> .....	69
Table 3.3 <i>Example of How Lessons Were Matched – Lesson 1 SO: Point of View</i> .....	75
Table 3.4 <i>Data Collected from Each Class</i> .....	77
Table 3.5 <i>Overview of the Analysis Process for the Qualitative Data</i> .....	78
Table 3.6 <i>Coding Used for Anghileri's Levels of Scaffolding Practices</i> .....	79
Table 3.7 <i>An Example of Analysis Using Scaffolding Coding</i> .....	80
Table 3.8 <i>Coding for Gesture Classification</i> .....	80
Table 3.9 <i>An Example of Analysis Using Scaffolding Coding and Gesture Coding</i> .....	81
Table 3.10 <i>An Example of Focal Analysis Using Pronounced, Attended and Intended Focus</i> ...	82
Table 3.11 <i>Meta-Level Rules Analysis of Teacher and Student Interactions</i> .....	83
Table 4.1 <i>Pre-Test Means and Standard Deviations of the Factor-Referenced Cognitive Measures (SO, SV1, SV2)</i> .....	91
Table 4.2 <i>Pre-Test Means and Standard Deviations of the Spatial Content Knowledge Measures (NO, NV1, NV2)</i> .....	91
Table 4.3 <i>One-Way ANOVA of Pre-Test Results for the Factor-Referenced Cognitive Measures</i> .....	92
Table 4.4 <i>One-Way ANOVA of Pre-Test Results for the Spatial Content Knowledge Measures</i> .....	92
Table 4.5 <i>One-Way ANOVA of Post-Test Results for the Factor-Referenced Cognitive Measures</i> .....	92
Table 4.6 <i>One-Way ANOVA of Post-Test Results for the Spatial Content Knowledge Measures</i> .....	93
Table 4.7 <i>Significant Variances Between the VM and Control Classes for the Factor-Referenced Cognitive Measures Post-Tests</i> .....	93
Table 4.8 <i>Significant Variances Between the VM and Control Classes for the Spatial Content Knowledge Measures Post-Tests</i> .....	93
Table 4.9 <i>Paired Sample t-Test Results (Pre-Test to Post-Test) for the Factor-Referenced Cognitive Measures: PM Class (n = 23)</i> .....	94
Table 4.10 <i>Paired Sample t-Test Results (Pre-Test to Post-Test) for the Spatial Content Knowledge Measures: PM Class (n = 23)</i> .....	94
Table 4.11 <i>Paired Sample t-Test Results (Pre-Test to Post-Test) for the Factor-Referenced Cognitive Measures: VM Class (n = 27)</i> .....	95
Table 4.12 <i>Paired Sample t-Test Results (Pre-Test to Post-Test) for the Spatial Content Knowledge Measures: VM Class (n = 27)</i> .....	95
Table 4.13 <i>Paired Sample t-Test Results (Pre-Test to Post-Test) for the Factor-Referenced Cognitive Measures: Control Class (n = 18)</i> .....	95
Table 4.14 <i>Paired Sample t-Test Results (Pre-Test to Post-Test) for the Spatial Content Knowledge Measures: Control Class (n = 18)</i> .....	96

Table 4.15 <i>Mean and Standard Deviation of the Factor-Referenced Cognitive Measures on the Three Different Occasions (Pre-Test, Post-Test, and Post-Post-Test): PM class (n = 23)</i> .....	97
Table 4.16 <i>Mean and Standard Deviation of the Spatial Content Knowledge Measures on the Three Different Occasions (Pre-Test, Post-Test, and Post-Post-Test): PM class (n = 23)</i> .....	97
Table 4.17 <i>One-Way Repeated Measure ANOVA Values for Factor-Referenced Cognitive Measures: PM Class</i> .....	97
Table 4.18 <i>One-Way Repeated Measure ANOVA Values for Spatial Content Knowledge Measures: PM Class</i> .....	97
Table 4.19 <i>Pairwise Comparison Significant Values for Factor-Referenced Cognitive Measures: PM Class</i> .....	98
Table 4.20 <i>Pairwise Comparison Significant Values for Spatial Content Knowledge Measures: PM Class</i> .....	98
Table 4.21 <i>Mean and Standard Deviation of the Factor-Referenced Cognitive Measures on the Three Different Occasions (Pre-Test, Post-Test, and Post-Post-Test): VM Class</i> ....	99
Table 4.22 <i>Mean and Standard Deviation of the Spatial Content Knowledge Measures on the Three Different Occasions (Pre-Test, Post-Test, and Post-Post-Test): VM Class</i> ....	99
Table 4.23 <i>One-Way Repeated Measure ANOVA Values for the Factor-Referenced Cognitive Measures: VM Class</i> .....	99
Table 4.24 <i>One-Way Repeated Measure ANOVA Values for the Spatial Content Knowledge Measures: VM Class</i> .....	99
Table 4.25 <i>Pairwise Comparison Significant Values for the Factor-Referenced Cognitive Measures: VM Class</i> .....	100
Table 4.26 <i>Pairwise Comparison Significant Values for the Spatial Content Knowledge Measures: VM Class</i> .....	100
Table 4.27 <i>Anghileri's Levels of Scaffolding Practices</i> .....	103
Table 4.28 <i>The Review Process Commonly Used in the Orientate Phase (L1SV PM 7: Utterance 11–16)</i> .....	105
Table 4.29 <i>Negotiation of Meaning (2RsD) Scaffold (L1SV PM 7: Utterance 30–32)</i> .....	106
Table 4.30 <i>Teacher Explanations (L2SO PM 6: Utterance 9–14)</i> .....	107
Table 4.31 <i>Student Explanation (L3SO PM 1: Utterance 176–185)</i> .....	110
Table 4.32 <i>Processes for Addressing Students' Misconceptions (L1SO PM 8: Utterance 78–88)</i> .....	112
Table 4.33 <i>Student Misconceptions Addressed Through Teacher Explain (2Ex) Scaffold (L3SO PM 1: Utterance 206–214)</i> .....	113
Table 4.34 <i>Teacher's Use of Rephrasing (2RsC) in the Synthesise Phase (L3SV PM 3: Utterance 21–25)</i> .....	114
Table 4.35 <i>Teacher's Use of Level 3 Scaffolds in the Synthesise Phase (L2SV PM 5: Utterance 40–42)</i> .....	115
Table 4.36 <i>Teacher's Attempt at Generating Mathematical Discourse (L3SO PM 7: Utterance 148–161)</i> .....	116
Table 4.37 <i>The Inclusion of 3C Scaffolding (L3SO VM 9: Utterance 45)</i> .....	120
Table 4.38 <i>The Inclusion of 3B Scaffolding (L3SO VM 9: Utterance 49)</i> .....	121
Table 4.39 <i>The Use of Rephrasing (L3SO VM 9: Utterance 52–53)</i> .....	122

Table 4.40 <i>Change in the Types of Explaining Structures (LISV VM 1: Utterance 14–16) .....</i>	124
Table 4.41 <i>Iconic Gesture as a Visual Representation of a Verbally Communicated Idea (L3SV VM 6: Utterance 41).....</i>	125
Table 4.42 <i>Iconic Gestures as a Clarifying Tool (L3SO VM 9: Utterance 42–43) .....</i>	125
Table 4.43 <i>Student Peer Scaffolding (L3SV VM 3: Utterance 25–33) .....</i>	127
Table 4.44 <i>Shift in the Level 2 Structure of Explain (L3SO VM 9: Utterance 95–98) .....</i>	129
Table 4.45 <i>Shift in the Level 2 Structure of Explain (L3SO VM 9: Utterance 105–112) .....</i>	130
Table 4.46 <i>More Complex Implementation of Level 3 Support Structure (LISO VM 1: Utterance 127–136).....</i>	132
Table 4.47 <i>Increased Student Peer Scaffolding (L3SV VM 3: Utterance 145–152) .....</i>	134
Table 4.48 <i>Students Challenging Teacher’s Explanation (L3SV VM 6: Utterance 87–90) .....</i>	135
Table 4.49 <i>Teacher Explain (2Ex) with Changed Paraphrasing (2RvC) Structure (LISO VM 1: Utterance 182–187).....</i>	138
Table 4.50 <i>Student Acknowledgement of the iPad’s Self-Correct Function (L2SV VM 6: Utterance 7–15).....</i>	140
Table 4.51 <i>Student Acknowledgement of Peer Scaffolding (L3SO VM 5: Utterance 200–213)</i>	141
Table 4.52 <i>Brief Overview of Lesson 3 of Spatial Orientation in the PM Class .....</i>	144
Table 4.53 <i>Brief Overview of Lesson 3 of Spatial Orientation in the VM Class .....</i>	144
Table 4.54 <i>Frequencies of Occurrence for Each Level of Scaffolding for Each Phase of the Lesson .....</i>	145
Table 4.55 <i>Number of Different Special Keywords (and Frequency of Use) Used by the Teacher in the Four Phases of Lesson 3 in the PM and VM Classes.....</i>	148
Table 4.56 <i>Frequency and Percentage Frequency of Different Gestures Used by the Teacher in Lesson 3 in the PM and VM Classes .....</i>	150
Table 4.57 <i>Frequency and Percentage Frequency of Overall Gestures Used by the Teacher in Each Phase of Lesson 3 in the PM and VM Classes .....</i>	152
Table 5.1 <i>Students’ Limited Language Use (LISO PM 8: Utterance 5–8), Orientate Phase ...</i>	161
Table 5.2 <i>Students’ Use of Simple Sentences (LISO PM 8: Utterance 46–50), Enhance: Explicit Modelling Phase.....</i>	162
Table 5.3 <i>Students’ Use of Short Phrases (L3SO PM 1: Utterance 179–183).....</i>	162
Table 5.4 <i>Students’ Use of Circumstances (L3SO PM 7: Utterance 27–28), Enhance: Guided Application Phase.....</i>	163
Table 5.5 <i>Students’ Use of Grounding Gestures (LISO PM 8: Utterance 5–8).....</i>	165
Table 5.6 <i>Students’ Use of Pointing Gestures (L3SO PM 7: Utterance 92–94) .....</i>	168
Table 5.7 <i>Students’ Use of Iconic Gestures (L3SO PM 7: Utterance 57 and 72) .....</i>	169
Table 5.8 <i>Students’ Use of Iconic Gestures (L3SO PM 7: Utterance 36) .....</i>	170
Table 5.9 <i>Example of Metaphoric Gesture Use in the PM Class (L3SO PM 1: Utterance 190).....</i>	170
Table 5.10 <i>Student’s Use of a Metaphoric Gesture (L3SO PM 1: Utterance 200) .....</i>	171
Table 5.11 <i>VM Student’s Use of Beat Gestures (L3SO VM 9: Utterance 33) .....</i>	171
Table 5.12 <i>Number of Different Special Keywords (and Frequency of Use) Used in the Four Phases of Lesson 3 by the PM and VM Students.....</i>	175



Table 5.13 <i>Frequency of Each Gesture Category Used by PM Students During Each Phase of Lesson 3</i> .....	176
Table 5.14 <i>Frequency of Each Gesture Category Used by VM Students During Each Phase of Lesson 3</i> .....	176
Table 5.15 <i>Use of Iconic Gestures (G2) in the Orientate Phase (L3SO VM 9: Utterance 42)</i> .	177
Table 5.16 <i>Use of Iconic Gesture (G2) in the Orientate Phase (L3SO VM 9: Utterance 69)</i> ...	178
Table 5.17 <i>Use of Grounding Gestures (GE) in the Enhance: Guided Application Phase (L3SO VM 1: Utterance 145–152)</i> .....	178
Table 5.18 <i>Use of Iconic Gestures (G2) in the Synthesise Phase (L3SO VM 5: Utterance 184)</i> .....	179
Table 5.19 <i>Teacher Rephrasing of Special Keywords (L3SO VM 9: Utterance 32–33)</i> .....	181
Table 5.20 <i>Student's Extension of Special Keywords (L3SO VM 9: Utterance 51–53)</i> .....	181

## Abstract

Previous research suggests spatial thinking is fundamental to mathematics learning (Bronowski, 1947; Clements & Sarama, 2007, 2011), and acts as a predictor for future mathematical achievement levels (Battista, 1990; Gunderson et al., 2012). However, research with regard to spatial thinking is almost non-existent in early years mathematics classrooms (Bruce, Moss, & Ross, 2012; Clements & Sarama, 2011; Newcombe & Frick, 2010; Sarama & Clements, 2009, 2011; Stipek, 2013), and how to teach it in these contexts has received little attention. Fewer studies again have focused on the use of virtual manipulatives in influencing young students' spatial thinking (Highfield & Mulligan, 2007; Ng & Sinclair, 2015). Despite a recent surge in studies exploring the influence of virtual manipulatives in mathematics classrooms, little is known about how these manipulatives compare to physical manipulatives, especially in regard to the changes that occur in the social interactions between teacher and students during the learning process. To date, there has been no comparative study conducted that explores the influence of different external representations (e.g., physical manipulatives and virtual manipulatives) on both the teaching and the learning aspects within mathematics classrooms. The purpose of this research is to explore the use of external representations (i.e., physical manipulatives as compared to virtual manipulatives) in the mathematics classroom and how these representations support young, disadvantaged students' spatial thinking. The use of manipulatives is a common starting point for the teaching and learning of spatial thinking.

Previous research on manipulative use (both physical and virtual) in mathematics education has yielded positive results with regard to student learning (Clements, 1999; Heddens, 1997; Highfield & Mulligan, 2007; Riconscente, 2013; Siemon et al., 2011; Warren, 2006; Warren & Miller, 2013). Recent studies indicate that these newer digital technologies promote interactions between visual and kinaesthetic learning, which have been shown to support the teaching and learning of spatial thinking (Battista, 2008; Bruce, McPherson, Sabeti, & Flynn, 2011; Clements & Sarama, 2011; Highfield & Mulligan, 2007; Jorgensen & Lowrie, 2012; Sinclair, de Freitas, & Ferrara, 2013; Sinclair & Moss, 2012). However, results from comparative studies between physical manipulatives and virtual manipulatives have been varied (e.g., Brown, 2007; Olkum, 2003; Suh, 2005). It is proposed that different types of manipulatives influence the teaching and learning of spatial thinking in different ways. By viewing the learning of spatial thinking through a sociocultural perspective, aspects of the teaching and learning of spatial learning in mathematics classrooms can be scrutinised.

A review of the literature generated two research questions that informed the research design of this study. These were:

1. *What influence do different external representations (e.g., physical manipulatives and virtual manipulatives) have on young students' learning of spatial thinking?*
2. *What changes occur in the teaching and learning of spatial thinking when using different external representations (e.g., physical manipulatives and virtual manipulatives)?*

Given that the study focused on exploring students' spatial thinking as they construct their knowledge from the interactions they experience with external representations, an interpretive paradigm was an appropriate epistemological, ontological and methodological stance adopted for the research. Vygotsky's (1978) sociocultural theory provided a lens to interpret the interaction between teacher and students. Practical application of this theory permitted a narrowing lens to pinpoint particular aspects of the teaching of spatial thinking and students' learning of spatial thinking. Within this study, these practical applications included the use of Anghileri's "hierarchy of scaffolding practices" (2006) and Sfard's "commognitive approach" (2008). The methodology for the study included teaching experiments. Data collection methods incorporated the use of pre-test, post-test and post post-testing using spatial testing material and observations of lessons from a teaching experiment ( $n = 68$ ) comprising six lessons (three based on spatial orientation concepts and three based on spatial visualisation concepts).

Findings from this study provide further insights into the teaching and learning of spatial thinking. First, the use of manipulatives (either physical or virtual) appears to be important to students' learning of spatial thinking. Furthermore, the use of virtual manipulatives increases the communicative functions used by students, thus benefiting their spatial thinking. Second, teachers need to be able to instantaneously access deep content and pedagogical knowledge in order to maintain their role as "more knowledgeable other" and continually contribute to the teaching and learning of spatial thinking. Finally, teaching and learning appears to be positively influenced when both the teacher and students are major contributors to the classroom discourse.

This study contributes to the understanding of how different external representations influence the teaching and learning of spatial thinking. Theoretical contributions to new knowledge include a hypothesised theory on the interaction between teacher, student and manipulatives type. Implications for future classroom practice include placing importance on the use of manipulatives and communication in mathematics classrooms. Furthermore, teachers need to be aware that their ability to instantaneously access deep levels of content and pedagogical knowledge to further develop students' spatial thinking is essential and that for optimum learning to occur, both the teacher and students need to be major contributors to the teaching and learning process.

## List of Abbreviations

2D	Two-dimensional
3D	Three-dimensional
AAMT	Australian Association of Mathematics Teachers
ACARA	Australian Curriculum, Assessment and Reporting Authority
ACER	Australian Council for Educational Research
ANOVA	Analysis of variance
apps	Applications (as in iPad apps)
DGE	Dynamic Geometry Environment
ICT	Information and Communication Technology
ICSEA	Index of Community Socio-Educational Advantage
IRE	Initiation–Response–Evaluation
IRF	Initiation–Response–Follow-up
LBOTE	Language background other than English
MERGA	Mathematics Education Research Group of Australasia
MKO	More knowledgeable other
NAEP	National Assessment of Educational Progress
NAPLAN	National Assessment Program: Literacy and Numeracy
NCTM	National Council of Teachers of Mathematics
NO	NAPLAN Spatial Orientation
NV	NAPLAN Spatial Visualisation
OECD	Organisation for Economic Co-operation and Development
PISA	Programme for International Student Assessment
PM	Physical manipulatives
PM students	Students in the physical manipulatives class
SCK	Spatial content knowledge
SES	Socio-economic status
SO	Spatial orientation
SV	Spatial visualisation
STEM	The learning of Science, Technology, Engineering and Mathematics
TIMSS	Trends in International Mathematics and Science Study
VM	Virtual manipulatives
VM students	Students in the virtual manipulatives class
ZPD	Zone of Proximal Development

## Glossary

Commognitive	A term created by Sfard (2008) to encapsulate that “thinking is an individualization of interpersonal communication” (2007, p. 571). The term is a hybrid of the words communication and cognitive to highlight that thinking is a dialogical endeavour with language and cognition fused together.
Commognitive conflict	Commognitive conflict involves situations where interlocutors differ in their use of words, how they view or interpret visual mediators, or in the discursive procedures and routines used to solve particular situations.
Endorsed narratives	An endorsed narrative is one of the characteristics of discourse used by Sfard (2008). It refers to any text, spoken or written, that is accepted as true or false. In the context of mathematics, it can refer to mathematical definitions, proofs and theorems.
External Representations	For the purposes of this study, external representations refer to the mathematical manipulatives used in the teaching process to teach the mathematical concepts (i.e., physical manipulatives and virtual manipulatives).
Gestures	Gestures involve any movements of the arms and hands that are used by interlocutors in acts of communication.
Interlocutor	An interlocutor is a person who takes part in a dialogue or conversation.
Internalisation	Internalisation involves a person’s use of cultural tools (e.g., language, gesture) that have been modelled by another person.
Kinaesthetic learning (or tactile learning)	Kinaesthetic learning is a learning style in which learning takes place by students carrying out physical activities, rather than listening to a lecture or watching demonstrations.
Language	Language is the method of communication (either spoken or written) consisting of the use of words in a structured and conventional way.
Mediation	Mediation involves the socialisation with people and the interaction with objects to assist one’s learning.
Manipulatives	Manipulatives are the external representations that are used as a “tool” for learning.
Mathematical words	Mathematical words involve the use of verbal language, including words, vocabulary and syntax.
Physical manipulatives	Physical manipulatives are the hands-on materials and objects that can be manipulated to assist learning in a mathematics lesson. These can include three-dimensional (3D) objects, two-dimensional (2D) shapes, mirrors, and so on.
Representations	Representations are the “tools” used to assist the teaching, learning and communication of mathematics and assist in the organisation and understanding of abstract ideas. These may

	include the use of language, gesture, diagrams, models, manipulatives, and so on.
Routines	Routines are the set of rules that govern the patterns of discourse found in the mathematics classroom.
Scaffolding	Scaffolding refers to the temporary support structures that teachers provide in assisting the development of new understandings, new concepts, and new abilities in learners.
Sociocultural theory	Sociocultural theory involves the construction of meaning through the use of cultural tools. These tools could include sign systems (e.g., language) and physical artefacts (e.g., representations). Through the use of cultural tools and various social interactions, students become aware of their thoughts and can make changes to their mental structures.
Spatial thinking	Spatial thinking involves the mathematical process of recognizing and manipulating spatial properties of objects, as well as, the spatial relation between objects (Mulligan, 2015). These include the spatial abilities that “allow us to represent, navigate, and interpret the world around us” (Lowrie, Logan, & Ramful, 2017, p. 171). For the purposes of this study, Spatial thinking involves the use of spatial skills associated with spatial orientation and spatial visualisation.
Spatial orientation	Spatial orientation is the ability to know where an object is in space and its relationship to the position of another object.
Spatial visualisation	Spatial visualisation is the ability to form a mental picture of two-dimensional (2D) and three-dimensional (3D) objects, as well as the ability to manipulate these mental images.
Teacher–learner agreement	The teacher–learner agreement is the agreed upon rules of discourse and the routines between the teacher and the learner. Changes in the teacher–learner agreement lead to commognitive conflict.
Virtual manipulatives	Within this study, virtual manipulatives are the digital materials and objects that can be manipulated to assist learning in a mathematics lesson (i.e., iPad apps).
Visual mediators	Visual mediator is the term used by Sfard (2008) for the symbolic presentations that form part of mathematical conversations. In other words, they are the visual and tangible objects used in mathematical learning. These can include the use of gestures or external representations.
Zone of Proximal Development	Zone of Proximal Development as termed by Vygotsky (1978) is “the distance between the actual development level as determined by independent problem solving and the level of potential development as determined through problem solving under adult guidance or in collaboration with more capable peers” (p. 86).

# Chapter 1: Introduction

---

## 1.1 CHAPTER OVERVIEW

The objective of this thesis was to explore the influence of different external representations on the teaching and learning of young disadvantaged students' spatial thinking. A sociocultural perspective provided a framework for the study. Perspectives on scaffolding and students' learning through communication provided the analytical lenses for the data collection and interpretation of results. The aim of the study was to explore the use of representations (i.e., physical manipulatives and virtual manipulatives) in the teaching and learning process and their influence on Year 3 students (aged 8–9 years). The study was undertaken as a response to the lack of research in the early years pertaining to (a) comparing the influence of different external representations on students' learning of spatial thinking; and (b) exploring how the teaching and learning of spatial thinking in the classroom context can be influenced by the different external representations used.

In this chapter, the background and context of the research are described. The problem is defined and the purposes of the study are outlined. The research questions are posed. The research questions and aim of the study are used to establish a design of how the research was conducted. The significance and scope of this research are considered. The final section of this chapter includes an outline of the remaining chapters of the thesis. Figure 1.1 presents an overview of the chapter.



*Figure 1.1.* Overview of Chapter 1.

## 1.2 BACKGROUND

For the past fifteen years, I have gained teaching experience in national and international school settings with a particular focus on early years education. Whilst teaching in these environments, I have been involved in researching and implementing various policies within each school system context. For example, one policy, on play and active engagement in young students' learning, evidenced the importance of sensory learning and discovery learning through play-based experiences, scaffolded by teachers. The British Curriculum allows these experiences to occur through a "Free Flow" initiative, where students move amongst classrooms, choosing their own learning. This promotes participation through free choice, which the literature suggests is more likely to increase engagement and learning (Stead, 2006).

Through the Free Flow initiative, mathematical insights were gained into the effective implementation of representational tools and teaching pedagogies. One insight was that educational kinesiology teaching approaches, such as "Brain-Gym", assist the learning of young students. Educational kinesiology is the "process of drawing out learning through natural movement experiences" (Dempsey, 2005, p. 3). This approach grew out of the works of Dennison and Dennison (1989) where certain movements were seen to improve students' learning and performance. It is conjectured that Brain-Gym uses movement to create neural pathways in the brain and these connections of communication allow the brain to access more of one's potential (Dempsey, 2005). The more one moves, the more it facilitates embodiment of learning, presenting a link between human cognition and human movement (Alibali & Nathan, 2012; Dempsey, 2005; Wilson, 2002). Observations with educational kinesiology and its relationship with embodied learning had me questioning how movement, interactions with manipulatives, and the use of different resources influence young students' learning. An additional insight gained was that the organisation and implementation of mathematical resources and manipulatives in the classroom requires careful planning, and their effectiveness is reliant on certain teaching pedagogical approaches.

When appointed to the role of Information and Communication Technology (ICT) coordinator, I began to question the influence new technologies had on students and their learning. The momentum for this present study arose from a pilot study conducted whilst in this role. iPads and iPods were introduced into early years classrooms and potential benefits were monitored. It was evident that students enjoyed using these new devices and seemed highly motivated to learn. One of the themes explored in this initiative was the educational benefit that iPads had for Language background other than English (LBOTE) learners. While the study



evidenced high levels of motivation, the impact on students’ cognitive development was difficult to ascertain (Spencer, 2013).

### 1.3 RESEARCH CONTEXT

While a national agenda of societal functionality is consistently acknowledged within Australia, over the last decade international assessments have shown that Australian students’ achievement rankings in literacy and numeracy have declined. Two main studies drive the national agenda in Australia: Trends in International Mathematics and Science Study (TIMSS); and Programme for International Student Assessment (PISA). PISA 2015 results indicated the Australian students’ mathematical literacy has significantly declined each year since 2003. Figure 1.2 presents these data.

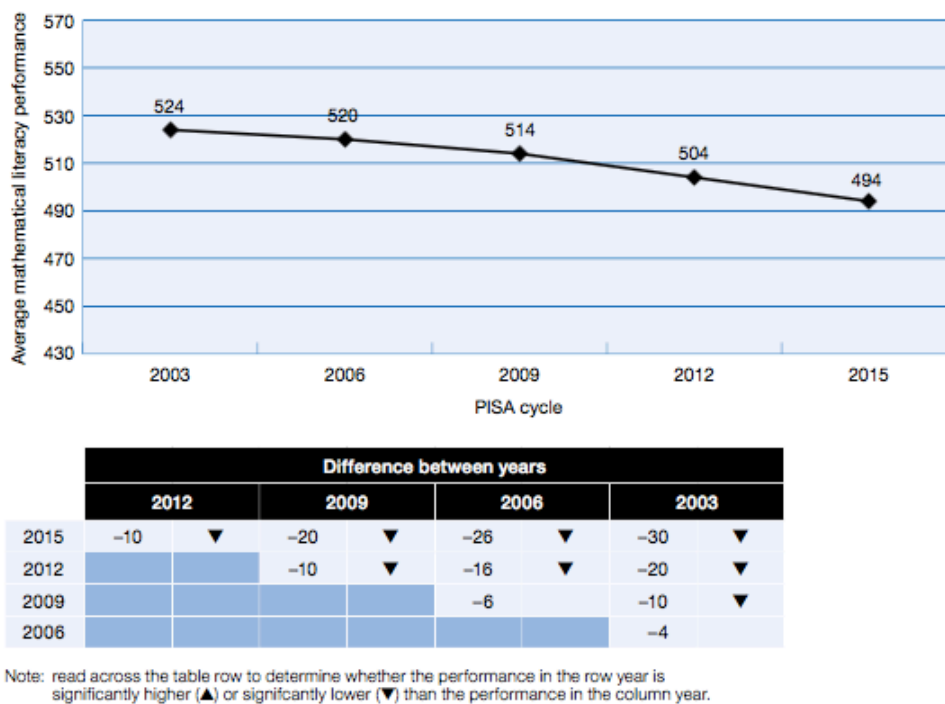

Figure 1.2. PISA 2015 average mathematical literacy performance and differences over time (Thomson, De Bortoli, & Underwood, 2017, p. 167).

TIMSS revealed that over the past decade, while Australian students’ achievement levels have remained fairly static, many other countries’ levels have increased (Ainley, Kos, & Nicholas, 2008; Thomson & Fleming, 2004; Thomson, Wernert, O’Grady, & Rodrigues, 2017). This has resulted in Australia’s mean scores being significantly lower than those of 21 other countries (Thomson, Wernert, et al., 2017). PISA shows similar results in mathematical literacy, with 14% of Australian students achieving below basic proficiency levels (Thomson, De Bortoli, & Underwood, 2017). Additionally, TIMSS 2015 reported that 30% of Year 4 students achieved at or below the international benchmark (Thomson, Wernert, et al., 2017). This is of

concern as the Organisation for Economic Co-operation and Development (OECD), the organising body of PISA, states that students below these levels are “at serious risk of not achieving at levels sufficient to allow them to adequately participate in the 21st century workforce and contribute as productive citizens” (Thomson & Hillman, 2010, p. 7).

The ability to understand and use mathematics is empowering for students and vital in today’s contemporary society. Studies have shown students’ mathematics achievement and engagement levels affect their ability to study higher levels of mathematics studies (Middleton & Spanias, 1999); their participation in post-school education (Stanley, 2008); their choice of careers (Jolly, Goos, & Smith, 2005); and their success in other subject areas (Frigo & Simpson, 2001). As Australian students’ mean scores in mathematical literacy have consistently dropped each year since 2000, concerns have been raised about the teaching and learning of mathematics that occurs in Australian schools. It is suggested that there may be complex issues within the mathematics classroom that require careful investigation of the teaching pedagogies and resources currently used. This decline is of even greater concern for students from disadvantaged backgrounds (Gonski et al., 2011).

Little evidence-based research exists as to how to assist these disadvantaged groups of young students to effectively learn mathematics. The introduction of NAPLAN data in 2008 provided many research opportunities and while numerous explorations have occurred, students from these contexts are still under-achieving. NAPLAN-related papers presented at the Australian Association of Mathematics Teachers and Mathematics Education Research Group of Australasia (AAMT-MERGA) conference in 2011 represented 10% of all papers (Leder, 2012). However, while two papers explored young Indigenous students’ learning (Edmonds-Wathen, 2011; Morley, 2011), neither paper explored the influence of socioeconomic status or lack of proficiency in Australian English on students’ achievement levels. This highlights the need to investigate the gap in current literature on how these disadvantaged cohorts of young children learn mathematics, and more particularly the strand of geometry.

### **1.3.1 Mathematics learning and educationally disadvantaged students**

Educationally disadvantaged students display a range of characteristics, including low levels of numeracy achievement and negative attitudes towards school. A series of studies based on Australian assessments have shown that a student’s background is associated with his/her achievement (Caldwell & Vaughan, 2011; Carmichael, MacDonald, & McFarland-Piazza, 2014; McConney & Perry, 2010a, 2010b; Perry & McConney, 2010; Vale et al., 2013). Many of these studies found students from disadvantaged contexts are more likely to exhibit the

following: lower levels of numeracy; lower higher-education participation rates; lower retention rates; less likelihood of studying specialised mathematics subjects; more likelihood of having difficulty with studies; and negative attitudes to school (Considine & Zappala, 2002). The key indicators of disadvantage reported to have a significant impact on students' educational performance are socio-economic status (SES), Indigeneity, English language proficiency, disability, and school remoteness (Gonski et al., 2011). This study focuses on participants who exhibit two of these indicators: SES and English language proficiency.

Young educationally disadvantaged students are performing at levels significantly behind their peers. International assessments have indicated that students' SES (i.e., derived from parental characteristics including occupational status, education, and family wealth or income) is significantly linked to achievement levels (Schleicher, 2008). Students from low-SES backgrounds generally have mathematics literacy scores lower than their peers, and are under-achieving at a level equivalent to almost three full years of schooling (Thomson & De Bortoli, 2008; Thomson, Hillman, & De Bortoli, 2012; Warren & Miller, 2013). Moreover, the statistically significant differences occur in different ages and across other numeracy areas (Daraganova & Ainley, 2012), and widen as these students progress through school (Australian Curriculum, Assessment and Reporting Authority [ACARA], 2009; Thomson, Wernert, Underwood, & Nicholas, 2008). Of greater concern is that around a quarter of these students fail to achieve baseline proficiency levels (Thomson & De Bortoli, 2008; Thomson, Hillman, & De Bortoli, 2012). Thus, students from disadvantaged contexts beginning school with mathematical knowledge lower than their peers (Griffin & Case, 1997) are also disadvantaged in their later mathematical achievement (Aubrey, Godfrey, & Dahl, 2006).

Results from both international and national data also raise concerns with regard to the achievement levels for LBOTE students from disadvantaged contexts. While investigation into LBOTE students' achievement levels has produced varied results (Gonski et al., 2011), international measures have shown the gap between LBOTE and non-LBOTE students is more pronounced for Australian students than for other similar countries (Thomson, De Bortoli, Nicholas, Hillman, & Buckley, 2011). Goldenberg (2008) also noted that students who exhibited the two factors of low English language proficiency and low SES were at greater risk of poor school outcomes. In Australia, the number of students who are identified as LBOTE is rapidly increasing in mainstream schools (Warren & Miller, 2015). This growing concern with regard to LBOTE students from disadvantaged contexts warrants further research.

These concerns are exacerbated in Queensland, a state with a large population of students from lower levels of PISA's rating of economic, social and cultural status (Thomson, De Bortoli,

& Underwood, 2017), and many LBOTE learners. On international assessments, Queensland's mean score was lower than the Australian mean score (Ainley et al., 2008; Thomson, Wernert, et al., 2017) and consistently lower than five states and territories (Thomson, De Bortoli, & Underwood, 2017). In addition, Queensland's scores have not significantly increased since TIMSS 1995 (Thomson, Wernert, et al., 2017) and a state review highlighted a marked decline in Queensland's mathematical literacy achievement since the 1970s (Masters, 2009). Recent PISA 2015 results illustrated this significant decline in students' mathematical literacy (Thomson, DeBortoli, & Underwood, 2017). Figure 1.3 presents these data.

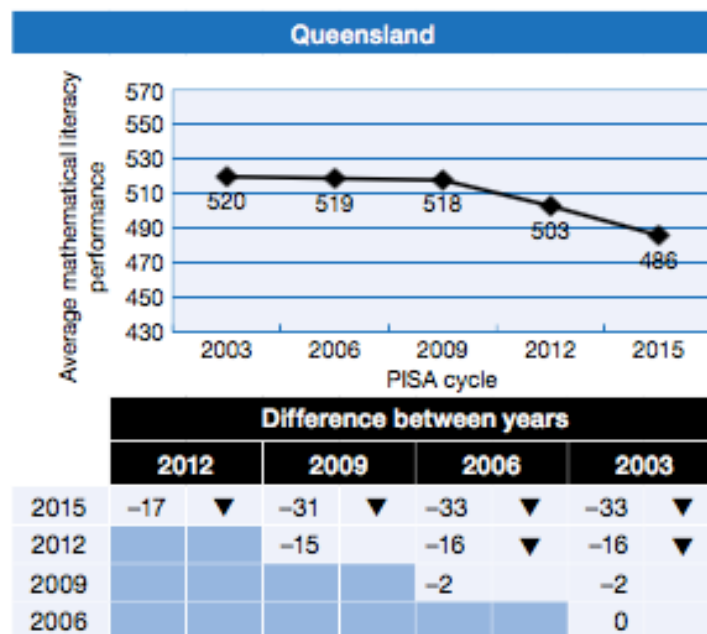

Figure 1.3. PISA 2015 average mathematical literacy performance and differences over time for Queensland (Thomson, De Bortoli, & Underwood, 2017, p. 174).

For Queensland, several key areas of concern have been established from these assessments. One area of concern was that the use of English in Australian classrooms is disadvantaging a substantial group of Queensland students who are from LBOTE backgrounds. As the main tool used by teachers when educating young students, oral language is acknowledged as crucial to their development (Aldridge, 2005; Krause, Bochner, Duchesne, & McMaugh, 2010). English proficiency has a powerful influence on young students' ability to comprehend and communicate their learning. This ability to communicate mathematically is crucial to learning mathematics (Setati, 2008). In mathematics, learning with extensive use of external representations, which are reinforced verbally, also occurs.

Additionally, the National Assessment Program for Literacy and Numeracy (NAPLAN) results have raised concerns about Queensland's poor performance in numeracy, especially in the area of geometry. Queensland students achieved less than 50% accuracy on questions relating to

the geometry component of 2008 NAPLAN (Klinken, 2010). On NAPLAN, geometry consists of two sets of skills: spatial orientation and spatial visualisation. “Spatial orientation is the ability to know where an object is in space and its relationship to the position of other objects” (Klinken, 2010, p. 302), for example mapping, while “spatial visualisation is the ability to form a mental picture of 2D and 3D shapes as well as the ability to manipulate them by mentally turning them in some way” (Klinken, 2010, p. 302). Klinken (2010) stated that it was the second skill set, spatial visualisation, which Queensland Year 3 students found particularly difficult. More recently, the 2014 Queensland state report for Year 3 students’ results from NAPLAN by the Queensland Curriculum and Assessment Authority indicated that Queensland results were approximately 2% below the national facility rate (% correct) and that this warranted further investigation. TIMSS showed similar issues with Year 4 students in the content area of geometry and measurement (Thomson, Hillman, Wernert, et al., 2012). The results in these areas (geometry and measurement) for students from disadvantaged backgrounds cause even greater concern (Thomson, Hillman, & De Bortoli, 2012; Thomson, Hillman, Wernert, et al., 2012).

#### **1.4 RESEARCH PROBLEM AND PURPOSE**

To achieve equity in education, exploration into how to support the learning of disadvantaged students of mathematics needs to occur. Warren and Miller (2013) suggested two main dimensions that need addressing: (a) teachers within these contexts need assistance to implement quality instruction; and (b) high-quality mathematics resources need to be provided to support students’ learning. Teachers in disadvantaged contexts often feel professionally, socially and geographically isolated, and many beginning teachers feel under-confident teaching mathematics (Jorgensen, 2010; Warren, 2009). Within these contexts, mathematics teaching is often highly structured and repetitive, relies heavily on worksheets, and teachers have lowered student learning expectations (Hewitson, 2007). It is suggested that providing learning environments with specialised instruction is imperative to improving disadvantaged students’ mathematical learning outcomes (Gervasoni et al., 2010).

Using multiple mathematical representations, such as charts, number lines, or even concrete and symbolic representations, is purported to improve students’ mathematical learning (e.g., Ainsworth, 2006; Kaput, 1992; Santos-Trigo, 2006; Warren & Miller, 2013). Therefore, it is hypothesised that the use of representations with disadvantaged students would yield similar results. This raises questions concerning the unique benefits that new technological resources and environments, particularly virtual manipulatives, provide in producing these multiple representations to support students’ cognitive development (Ainsworth, 2006;

Hennessy, Fung, & Scanlon, 2001; Lowrie, Jorgensen, & Logan, 2012; Moyer, 2001; Moyer-Packenham & Suh, 2011). Previous studies have shown that early years mathematics achievement levels are related to stronger mathematical achievement levels in later years (e.g., Jolly et al., 2005; Middleton & Spanias, 1999; Stanley, 2008) and that gaps in the early years results in greater gaps in later years of schools (Daraganova & Ainley, 2012; Thomson et al., 2008). This widening gap is particularly evident in students from low-SES backgrounds (Aubrey et al., 2006; Griffin & Case, 1997). Therefore, investigation into the benefits of virtual manipulatives and the use of representations within these devices is warranted.

Technology use, supported by a government-led agenda, has become more predominant in the Australian education system (Office of the Chief Scientist, 2016). However, this rapid implementation of technological resources into classrooms is insufficiently supported by research (Highfield & Goodwin, 2008; Lieberman, Fisk, & Biely, 2009). In the past decade, research into the benefits of virtual manipulatives has increased (Clements & Sarama, 2014; Moyer, 2001; Moyer, Bolyard, & Spikell, 2002; Moyer, Salkind, & Bolyard, 2008; Moyer-Packenham et al., 2015; Moyer-Packenham & Suh, 2011; Moyer-Packenham & Westenskow, 2013; Reimer & Moyer, 2005; Tucker, 2015). Their use is purported to promote confidence and independence in all learners, particularly those reluctant to learn, regardless of their year level or age (Murray, 2010). However, there is a paucity of research on the experiences of disadvantaged students with virtual manipulatives. The influx in technology use, coupled with the booming “i-learning” culture that followed the introduction of the iPad, presents an opportunity to investigate the influences that virtual manipulatives have on students’ mathematical achievement and cognitive development. With young Australian students underperforming in mathematics, and educationally disadvantaged students falling even further behind, more research on how these representations support these students’ learning is warranted.

The purpose of this research is to explore the use of external representations (i.e., physical manipulatives as compared to virtual manipulatives) in the mathematics classroom and how these representations support students’ spatial thinking. The context of educationally disadvantaged students and the purported influence representations have on their cognitive development provides a framework for the research. As little is known within this context, this study aims to add insights to this field. It proposes to begin to fill the gaps in recent literature with regard to the influence virtual manipulatives have on young, educationally disadvantaged students’ learning.

## **1.5 AIMS AND RESEARCH QUESTIONS**

The first aim is to explore the influence of different external representations on young disadvantaged students' learning of spatial thinking. For the purposes of this study, the external representations investigated include the mathematical manipulatives used (i.e., physical manipulatives and virtual manipulatives) and students' use of language. The second aim is to investigate the effect of these different external representations on the teaching and learning process within a mathematics classroom. This includes changes in the teaching pedagogy used by the teacher and the influence of these changes on the students' learning.

### **1.5.1 Research questions**

After examining the literature (Chapter 2), two research questions were generated. This in turn informed the research design implemented for this study and guided the data collection and analysis. The research questions were:

1. *What influence do different external representations (e.g., physical manipulatives and virtual manipulatives) have on young students' learning of spatial thinking?*
2. *What changes occur in the teaching and learning of spatial thinking when using different external representations (e.g., physical manipulatives and virtual manipulatives)?*

## **1.6 RESEARCH DESIGN**

### **1.6.1 Epistemology**

Because the study explores students' spatial thinking as they construct their knowledge from the interactions they experience with external representations, an interpretive paradigm is an appropriate epistemological, ontological and methodological stance adopted for the research (Denzin & Lincoln, 2005). Within an interpretive paradigm, it is suggested that making "meaning" or "knowledge" is a product of social interaction (Stahl, 2003). During this process, students use language, gestures and other social interactions to assist in the creation of their understanding. The epistemology allows for the exploration of students' spatial thinking as they construct their knowledge from a known context, the manipulation of objects within their environment.

### **1.6.2 Theoretical perspective**

The theoretical lens applied to this study was a sociocultural perspective, as introduced by Vygotsky (1978). As discussed in Chapter 2, the literature review, practical application of this theory permitted a narrowing lens to pinpoint particular aspects of the teaching of spatial thinking and students' learning of spatial thinking. Within this study, these practical applications included the use of Anghileri's "hierarchy of scaffolding practices" (2006) and Sfard's "commognitive approach" (2008).

### **1.6.3 Research methodology**

Case studies were used to explore and describe the phenomenon of students' learning of spatial thinking, within the classroom context, using a variety of data sources (Yin, 2003). While the majority of data collected were qualitative, the inclusion of quantitative data occurred through the use of spatial testing materials. The purpose of the spatial tests was threefold: (a) to gauge the understanding of students' spatial concepts at the commencement of the study; (b) to guide the selection of lessons used in the teaching experiments; and (c) to measure the gains in students' understanding of spatial concepts at the conclusion of the study. The purpose of the teaching experiments was to directly experience students' learning of spatial thinking (Steffe & Thompson, 2000). The teaching experiments were applied using a quasi-experimental design to allow observation of the impact of an intervention (i.e., either physical or virtual manipulatives) on its targeted population without the use of random assignment (Shadish, Cook, & Campbell, 2002). A quasi-experimental design ensured that the natural setting was preserved in order to investigate the interactions that support the development of students' spatial thinking.

### **1.6.4 Participants**

The research was conducted in three Year 3 classrooms from two disadvantaged schools in south-east Queensland. In total, 68 students (aged 8–9 years old) participated in the study. Two classes ( $n = 50$  students) from School A participated in the quasi-experimental teaching experiments. One class ( $n = 23$  students) used physical manipulatives (PM) and the other class ( $n = 27$  students) used virtual manipulatives (VM). One class ( $n = 18$ ) from School B participated as the control class. The researcher was also a participant of the study as she adopted the role of the teacher during the data collection phase.

### **1.6.5 Data collection strategies**

To explore the influences of external representations on students' learning of spatial thinking, several data-gathering strategies were used. These included:



1. initial classroom observations;
2. pre-test, post-test and post-post-testing using spatial testing material; and
3. teaching experiments with two classes from School A, comprising six lessons (three based on spatial orientation concepts and three based on spatial visualisation concepts).

## **1.7 SIGNIFICANCE OF RESEARCH**

The study aims to make a contribution to mathematics education research within the field of young students' learning of spatial thinking and the use of different manipulatives. There is a paucity of research on technology resources, particularly virtual manipulatives, and their use within early years classrooms. "These tools afford representational expression and shape mathematics learning, but there are few studies that describe the representational process of young learners" (Highfield & Goodwin, 2008, p. 260). Examination of external representations and how they influence young students' learning has primarily focused on physical manipulatives, highlighting the need to further investigate virtual manipulatives. While studies into early childhood mathematics has surged (Perry and Dockett, 2007), the use and impact of technology within these early years' settings appears to be not widely researched (Clements & Sarama, 2014), especially within an Australian context (Fox, 2007; Groves, Mousley, & Forgasz, 2006; Mulligan & Vergnaud, 2006; Perry & Dockett, 2004, 2007). With new technologies, particularly game-based environments, some researchers argue that these have the possibility of altering young students' learning trajectories, however, research is yet to validate these claims (Clements & Sarama, 2014; Perry & Dockett, 2004). With a paucity of research examining the use of technology in early years' mathematics (Sarama & Clements, 2003; Yelland 2000, 2005), the value of the current study is that it offers the opportunity to build on prior research and expand our knowledge about the learning of educationally disadvantaged students. It is acknowledged, both nationally and internationally, that these cohorts of learners are falling further behind their peers in regard to mathematics achievement (Thomson & De Bortoli, 2008; Thomson et al., 2011; Warren & Miller, 2013). As little is known about how these students learn mathematics, a study into the influences of representations on their cognitive development has the potential to deepen our understanding into the learning process of disadvantaged students.

Additionally, the study aims to make a significant contribution to research that examines the influence of external representations (i.e., physical and virtual manipulatives) on the teaching and learning process. By exploring the changes in the pedagogies adopted by the

teacher and the influence of different external representations on these practices, a better understanding of students' learning of spatial thinking can be gained. Despite a recent surge in studies exploring the influence of virtual manipulatives in mathematics classrooms, little is known about how these manipulatives compare to physical manipulatives, especially in regard to the changes that occur in the social interactions between teacher and students.

## **1.8 THESIS OUTLINE**

### **1.8.1 Chapter 1: Introduction**

In this chapter, the background and context of the study were described, and the significance of the research problem was defined. Two research questions were identified and the directions for the data collection were proposed.

### **1.8.2 Chapter 2: Literature Review**

This chapter presents a review of the literature relating to the teaching and learning of spatial thinking. This review explores how the theoretical perspective of sociocultural theory influences students' learning. Additionally, the review examines the practical applications of a sociocultural perspective, including the use of Anghileri's hierarchy of scaffolding practices (2006) and Sfard's commognitive approach (2001), and discusses how this can be applied to scrutinise teaching and learning within the context of a mathematics classroom.

### **1.8.3 Chapter 3: Research Design**

This chapter describes and justifies the research design and the methodological approaches used. The data collection stages are elaborated and the methods of analysis are outlined. Issues related to the validity and trustworthiness of the study are assessed and ethical considerations of the study are also examined.

### **1.8.4 Chapter 4: Findings – Spatial Thinking and Teaching**

Presented in this chapter are the results of the spatial testing material. These results comprise pre-test, post-test and post post-test results from each of the treatment classes, in addition to pre-test and post-test results from the control class. The findings from the teaching experiment lessons are analysed according to the scaffolding practices implemented by the teacher.

### **1.8.5 Chapter 5: Findings – Student Learning**

Presented in this chapter are the findings from the teaching experiment lessons related to students' learning of spatial thinking. The analysis of the data was considered in the light of students' learning in relation to their communication. Analysis of students' communication included examination of changes in their use of mathematical words (language) and visual mediators (gestures).

### **1.8.6 Chapter 6: Discussion**

A Synthesise of the results and insights from Chapters 4 and 5 is presented in this chapter. The findings of the study are discussed and interpreted with reference to the literature critiqued in Chapter 2.

### **1.8.7 Chapter 7: Conclusions and Recommendations**

The final chapter addresses the research questions. The contributions of the study to existing research and theory are identified and a framework for the influence of external representations on the teaching and learning of spatial thinking is developed. The limitations of the study are presented and recommendations for further research are made.



# Chapter 2: Literature Review

---

## 2.1 CHAPTER OVERVIEW

The purpose of this chapter is to present the review of the literature related to the influences on early years students' spatial thinking. The review of the literature begins by examining the concepts of spatial thinking and the difficulties that students experience with spatial thinking. In particular, the focus includes defining the two dimensions of spatial thinking: spatial orientation and spatial visualisation. This is followed by an examination of the representational literature, which allows for a Synthesise of the literature pertaining to the different types of representations, how these representations interact with each other and how transference between different representations is essential for mathematics learning. Physical and virtual manipulatives are defined and compared, as they are utilised in the teaching and learning of spatial thinking. Finally, as teaching and learning are interactive, social endeavours, a theoretical framework based on sociocultural theory is delineated. This theoretical framework is grounded in the works of Vygotsky (1978). Two different analytical approaches (lenses), Anghileri's (2006) hierarchy of scaffolding practices and Sfard's (2001) commognitive approach to learning, are Synthesised within this sociocultural stance. These lenses were subsequently used to analyse the teaching of spatial thinking and how communication is used to interpret students' learning (see Chapters 4 and 5). A review of the literature is presented at the conclusion of the chapter. Figure 2.1 presents an overview of Chapter 2.

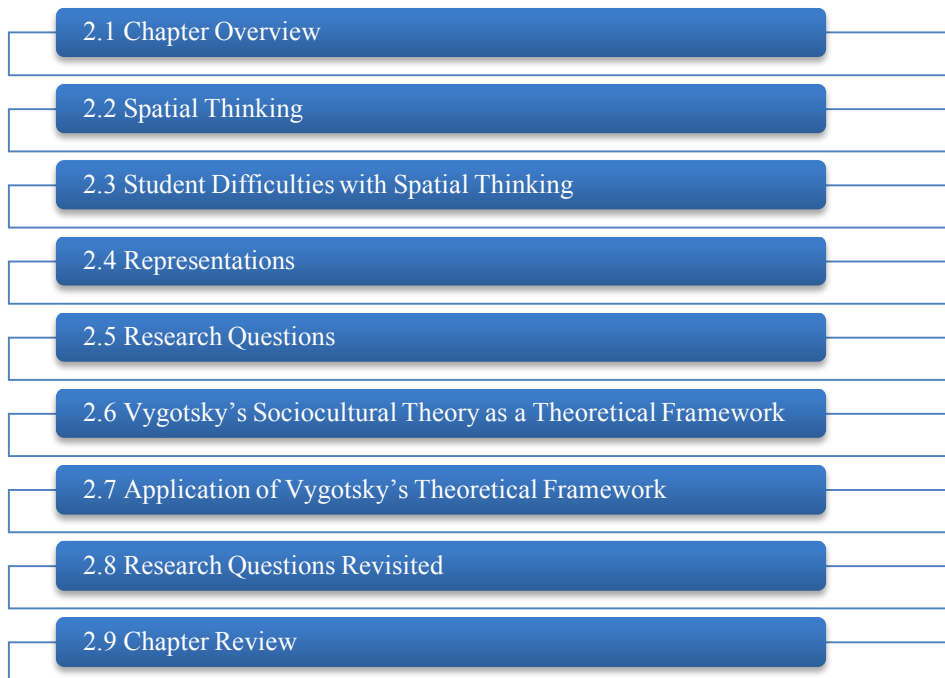

2.1 Chapter Overview	
2.2 Spatial Thinking	
2.3 Student Difficulties with Spatial Thinking	
2.4 Representations	
2.5 Research Questions	
2.6 Vygotsky's Sociocultural Theory as a Theoretical Framework	
2.7 Application of Vygotsky's Theoretical Framework	
2.8 Research Questions Revisited	
2.9 Chapter Review	

## 2.2 SPATIAL THINKING

Over the past decade, literature reviews pertaining to the teaching and learning of spatial thinking have increased (Newcombe & Stieff, 2012); however, researchers have reached little consensus with respect to defining spatial thinking (Hegarty & Waller, 2005; Uttal & Cohen, 2012). Within the literature, researchers have labelled spatial thinking in different ways: spatial reasoning (Battista & Clements, 1992); visual reasoning (Rivera, 2011); visuo-spatial reasoning (Healy & Powell, 2013; Lowrie, Logan, & Scriven, 2012; Owens, 2015; Tversky, 2004); visuo-spatial thinking (Shah & Miyake, 2005); and visualisation (Clements, 2012). While many different terms exist, they all encapsulate the common conception of “the activity of imagining static or dynamic objects and acting on them (mentally rotating, stretching, etc.)” (Sinclair et al., 2016, p. 691). For this present study, the term “spatial thinking” is adopted. Spatial thinking involves the mathematical process of recognizing and manipulating spatial properties of objects, as well as, the spatial relation between objects (Mulligan, 2015). These include the spatial abilities that “allow us to represent, navigate, and interpret the world around us” (Lowrie, Logan, & Ramful, 2017, p. 171).

Although there is no agreed-upon term and definition for spatial thinking, various researchers have identified a number of critical skills within the spatial domain of mathematics education. Some researchers (e.g., Linn & Petersen, 1985) proposed that spatial thinking consists of three spatial skills: mental rotation (imagining the rotation of 2D or 3D objects); spatial perception (comprehending spatial relations using one’s body as a reference point); and spatial visualisation (processing alterations of spatial figures, such as paper folding). Other researchers (e.g., Carroll, 1993) grouped all three dimensions together under the one term, spatial visualisation. In addition, a study by Clements (1999) suggested spatial thinking skills involved studying three aspects: spatial objects (e.g., lines and shapes); their relationships with each other (e.g., “equal in measure”); and transformations of these objects (e.g., rotations and reflections).

More recently, Newcombe, Uttal, and Sauter (2013) claimed that there were two types of spatial skills associated with spatial thinking: (a) “between-object representation and transformation skills” (i.e., a perspective-taking task); and (b) “within-object representation and transformation skills” (i.e., a mental rotation task). These two types of spatial skills align with Mulligan’s (2015) stance that spatial thinking “refers to the ability to recognise and [mentally] manipulate the spatial properties of objects and the spatial relations among objects” (p. 513).

While Kinach (2012) appeared to adopt a two-component understanding of spatial thinking, he also added,

[Spatial thinking] takes a variety of forms, including building and manipulating two- and three-dimensional objects; perceiving an object from different perspectives; and using diagrams, drawings, graphs, models, and other concrete means to explore, investigate, and understand abstract concepts such as algebraic formulas or models of the physical world. (p. 535)

The use of Kinach's definition extends previous understandings of spatial thinking by not only acknowledging the existence of two components to spatial thinking (i.e., mentally manipulating objects, and perceiving them from different perspectives), but also highlighting the influence of representations on spatial thinking within the act of teaching and learning. Numerous researchers concur that the role representations play is important to developing spatial thinking (e.g., Barrista, 2007; Bishop, 1983; Clements, 1999, 2004; Clements & McMillen, 1996; Newcombe, 2010). In addition, Newcombe (2010) acknowledged the importance of instructional practices and technology in fostering these skills.

The two types of spatial thinking delineated by Newcombe et al. (2013) and Mulligan (2015) are also reflected in national and international curriculum documents. For example, in the United States, the *Principles and Standards for School Mathematics* (National Council of Teachers of Mathematics [NCTM], 2000), splits spatial thinking skills into: (a) locations (relative position in space) and using visualisation (including using spatial memory and visualisation to create mental images of geometric shapes); and (b) representing and recognising shapes from different perspectives. Similar definitions are also reflected in England's (Department for Education, 2014) and Australia's (ACARA, 2014) curriculum documents, and in the numeracy general capabilities of the Australian curriculum (ACARA, 2014).

This present study reflects the findings of recent research (e.g., Kinach, 2012; Mulligan, 2015; Newcombe et al., 2013) and defines spatial thinking as consisting of two components, namely, spatial orientation and spatial visualisation. These two forms of spatial thinking are further defined in the next subsection.

## **2.2.1 Defining spatial orientation and spatial visualisation**

### ***2.2.1.1 Spatial orientation***

Spatial orientation (SO) is defined as the "ability to know where an object is in space and its relationship to the position of other objects" (Klinken, 2010, p. 302). In other words, it is related to the position of an object compared to other objects (e.g., Kozhevnikov & Hegarty,

2001; Newcombe & Huttenlocher, 1992; Newcombe & Shipley, 2015; Pittalis & Christou, 2010). Importantly, this ability involves “understanding and operating on relationships between different positions in space, especially with respect to your own position” (Clements, 2004, p. 278). Thus, spatial orientation encompasses the following:

- mentally rotating objects, such as the skills involved in reading maps (Pazzaglia & Moe, 2013);
- orientating and navigating, such as understanding environmental directions (e.g., above, over and behind) and navigational ideas (e.g., left, right and front; Linn & Petersen, 1985); and
- ideas related to distance and measurement, which include using various reference frames, such as self-rotation or object-rotation, as found in Hegarty and Walker’s (2004) study.

Children begin to develop the notion of spatial orientation before they begin formal schooling. This is evidenced by:

- infants (< 24 months) who associate objects as being near a parent, but cannot associate objects related to landmarks (Presson & Somerville, 1985);
- three-year-olds who can build simple maps with miniature house, car and tree toys (Blaut & Stea, 1974); and
- kindergarten (3- to 4-year-old) students who can make models of their classrooms (Siegel & Schadler, 1977).

In relation to young students’ spatial memory and processing capacity (Anooshian, Pascal, & McCreath, 1984), researchers (e.g., Clements, 1999) continue to note the importance of representations (e.g., working with building blocks) to build students’ experiences with viewing objects from different perspectives (e.g., top-down view, front view, back view).

### ***2.2.1.2 Spatial visualisation***

By contrast, spatial visualisation (SV) is defined as the “ability to form a mental picture of 2D and 3D shapes as well as the ability to manipulate them by mentally turning them in some way” (Klinken, 2010, p. 302). This involves manipulating images within the mind (Clements & Battista, 1992; Hegarty & Waller, 2005; Kozhevnikov & Hegarty, 2001). As Clements (1999) described, spatial visualisation involves “understanding and performing imagined movements of two- and three-dimensional objects” (p. 18). Therefore, spatial visualisation encompasses the skills of creating a mental image and manipulating it. Development of spatial visualisation begins with the re-creation of static images, and progresses to developing dynamic motions of these



images (e.g., mentally rotating a shape to compare it to another shape; Clements, 2004; Hegarty & Waller, 2005). In other words, spatial visualisation comprises mental manipulation of objects. For the purposes of this study, spatial visualisation involves students' recognising features of two-dimensional shapes and three-dimensional objects, and mentally manipulating these shapes (e.g., visually folding two-dimensional nets into three-dimensional objects or visualising the mirrored image to create symmetrical patterns).

### **2.2.2 Teaching spatial thinking**

There are four main reasons for the inclusion of spatial thinking in students' mathematical learning. First, spatial thinking is fundamental to mathematics learning, as concepts related to spatial thinking are claimed to underpin mathematical thought (e.g., Bronowski, 1947; Clements & Sarama, 2007, 2011). As a natural occurrence, spatial thinking can be found in many free-play activities that young students engage in, evidencing that these skills emerge early in young students' development (deHevia & Spelke, 2010). For example, young students often produce symmetry in their free play with blocks (Seo & Ginsburg, 2004), and have been seen to use simple maps and scale models to find objects in a room (Uttal & O'Doherty, 2008). Spatial thinking skills are also reported as central to Science, Technology, Engineering and Mathematics (STEM) success (Newcombe, 2010), because "much of the thinking that is required in higher mathematics is spatial in nature" (Jones, 2001, p. 55).

Second, spatial thinking can act as a predictor for subsequent mathematical achievement, and achievement in other discipline areas (Battista, 1990), particularly within the secondary context. While a study by Gunderson and colleagues (2012) found that students' spatial thinking at the age of five was a predictor of their performances on numerical measures at the age of eight, studies within an early years context are limited. Within a secondary context, researchers have claimed that students with elevated spatial thinking skills are more likely to engage with and experience success in STEM disciplines (Shae, Lubinski, & Benbow, 2001; Wai, Lubinski, & Benbow, 2009; Webb, Lubinski, & Benbow, 2007). In addition, positive links have been made between spatial thinking and creativity across all disciplines (e.g., Kell, Lubinski, Benbow, & Steiger, 2013). As Marjorie Senechal (as cited in Clements & Sarama, 2011) stated:

Geometry should be a focus at every age, in every grade, every year. Mathematics curricula are often criticized for their insularity—"what does this have to do with the real world?" No mathematical subject is more relevant than geometry. It lies at the heart of physics, chemistry, biology, geology and geography, art and architecture. It also lies at the heart of mathematics, ... The elementary school curriculum should give the children the tools they will need tomorrow. (p. 138)

Third, knowledge and understanding of spatial language is fundamental to the learning of other mathematical concept areas and thus should be prioritised in early years education (Clements, 1999; Clements & Sarama, 2007; National Research Council, 2006). Mathematics is a unique language that helps both teachers and students to represent mathematical concepts, and thus performs a pivotal role in the mathematical learning process (Smith, 1964). There is a significant body of research that acknowledges the importance of the use of spatial language as a representational system to mathematics learning (e.g., Cairney, 2003; Clements, 1999; Cuoco & Curcio, 2001; Goldin, 2003; Goldin & Janvier, 1998; Goldin & Shteingold, 2001; Heritage & Niemi, 2006; Kilpatrick, Swafford, & Findell, 2001). For example, spatial relationships dealing with location are central to understanding counting, ordinality, symmetry, permutations, and patterns (Greene, 1999). Even the terms “after”, “next”, “before” and “between” are spatially related ideas. When asking students to perform tasks, such as to identify what number comes after another number when counting or what comes next in a pattern, students require an understanding of the elements of location. Consequently, it has been suggested that it is best to start teaching young students spatial thinking skills prior to introducing numbers, as numbers are considered more abstract and require spatial language (Furner & Marinas, 2011).

Finally, spatial thinking offers opportunities for students to acquire visualisation skills (Jones, 2002), skills that are fundamental to human existence in today’s world. Spatial thinking skills allow humans to navigate the world, manipulate objects and visually imagine our surroundings (van den Heuvel-Panhuizen, Elia, & Robitzsch, 2015). Additionally, many aspects of cultural life are visual. For example, geometric principles of symmetry, perspective, scale, and orientation are found within art, architecture, and music. Important life skills, such as navigation, orienteering and map reading require spatial thinking (Jones, 2002). Recently, spatial thinking has become increasingly more fundamental to functioning in modern society (Mulligan, 2015). This is especially evident in recent developments in information-based communication, where the interfaces are less dependent on alphanumeric processing and more on visuo-spatial (Mulligan, 2015). Therefore, young students’ ability to successfully function in later life is dependent on their mastery of skills related to spatial thinking.

Despite evidence linking the importance of spatial thinking to mathematics understanding (Ansari et al., 2003; Arcavi, 2003; Casey, Nuttall, & Pezaris, 2001; Clements & Sarama, 2007, 2011; Delgado & Prieto, 2004; Farmer et al., 2013; Guay & McDaniel, 1977; Kurdek & Sinclair, 2001; Lachance & Mazzocco, 2006), spatial thinking is under-taught and under-researched in early years education (Newcombe & Frick, 2010; Sarama & Clements, 2009, 2011). While previous research within a secondary context highlights spatial thinking as an area

that deserves comprehensive exploration, research on young students’ development of spatial thinking is almost non-existent. There is ample research supporting why young students’ spatial thinking is fundamental to mathematics and other aspects of human life. However, there is a paucity of research pertaining to our understanding of how young students develop spatial thinking and how to assist teachers to support its development within the early years context.

### 2.2.3 Van Hiele’s model and Piaget’s theory for developing spatial thinking

From the plethora of theoretical perspectives concerned with development of geometric concepts (in which spatial thinking skills are essential), a predominant perspective, noted by many researchers within the field, is that of Van Hiele (1986). Van Hiele’s model presents five levels of thought that students progress through as they develop their understanding of geometric concepts. Table 2.1 presents the five levels of thought together with a description of the types of actions students exhibit at each level.

Table 2.1

*Five Levels of Thought Together with a Description of Students’ Actions at Each Level*

Level	Description of students’ actions	Example
1. Visualisation	Recognises shapes as a whole but cannot form mental images of them. Attributes and properties of the shape are not considered. Relies on concrete examples to identify shapes and figures.	A rectangular figure is recognised as it looks “like a door”.
2. Descriptive/Analysis	Describes shapes in terms of their properties. Often fails to recognise the relationship between the properties. Begins to use emerging properties to conceptualise shape categories.	A square consists of “four sides and four right angles”.
3. Informal deduction	Begins to identify relationships between shape classifications.	A special form of a rectangle can be known as a square.
4. Formal deduction	Begins to use deduction.	
5. Rigor	Can establish and compare mathematical systems.	

As students in elementary school mainly operate within the first two levels of Van Hiele’s model (i.e., visualisation and descriptive/analysis; Clements, 1999; Clements & Sarama, 2011; Crowley, 1987), and given that the participants in this study are in the early years of schooling, these two levels inform the focus of the content covered in this study.

Van Hiele (1986) acknowledged that his levels of geometric thought were rooted in Piaget and Inhelder’s (1967) stages of spatial thinking, viewed as a progression from “perceptual space” to “representational space”. Piaget and Inhelder postulated that spatial thinking develops

through the existence of cognitive schemes that are established through a process of “internalisation” as students enact with objects within their environment (Driver, Asoko, Leach, Mortimer, & Scott, 1994). These schemes evolve through “equilibration”, a process of adapting to more complex experiences. In simpler terms, new schemes develop from modification of older schemes and intellectual development occurs through a progressive adaptation of students’ cognitive schemes within a physical environment. Additionally, Piaget and Inhelder believed that intellectual development and students’ progressive adaptation was age related. A criticism by Van Hiele of Piaget and Inhelder’s conclusions was that levels of intellectual development are not purely related to the subject matter under investigation, but are construed by one’s thinking, and thus are not age-bound. Numerous studies (e.g., Flavell, Everet, Croft, & Flavell, 1981; Newcombe, 1989; Newcombe & Huttenlocher, 1992) support this argument against Piaget’s age norms.

Building on Piaget’s findings, Van Hiele suggested the importance of the teacher in the instructional process of developing students’ spatial thinking. To guide the teacher, Van Hiele’s model offered a list of properties associated with the levels that are claimed to help teachers progress spatial thinking of students through the levels of geometric thought (Crowley, 1987). These properties are as follows:

- sequential – students must progress through the levels in order;
- advancement – progression through the levels is more dependent on the content and methods of instruction used by the teacher rather than the age of the student;
- intrinsic and extrinsic – spatial concepts understood and objects used at one level are explicitly understood in the next level;
- linguistics – “each level has its own linguistic symbols and its own systems of relations connecting these symbols” (Van Hiele, 1986, p. 246) and therefore its own language (Clements & Battista, 1992; Crowley, 1987); and
- mismatch – instruction must be matched to the student’s level, because if the teacher operates at a higher level than the student, learning will not be understood (Crowley, 1987).

### ***2.2.3.1 Phases of learning***

In Van Hiele’s developmental model of geometric thought, students pass through the “five sequential phases of learning (inquiry, directed orientation, explication, free orientation, and free integration) before elevating to the next level of geometric thought” (Shaughnessy & Burger, 1985, p. 420). In the *inquiry* phase, students engage in conversations and activities

where “observations are made, questions are raised and level-specific vocabulary is introduced” (Hoffer, 1983, p. 208). There are two purposes of the inquiry phase: (a) the teacher learns students’ prior knowledge of the topic; and (b) the direction of the learning is identified for students (Crowley, 1987). During the second phase, *directed orientation*, the teacher prepares carefully sequenced activities using materials to explore topics (e.g., using a geo-board to construct a rhombus). This phase is heavily reliant on physical manipulatives as it involves playing and experimenting with geometric features of the shape. The *explication* phase builds on students’ previous experiences. The focus of this phase is on students communicating their evolving beliefs about the shapes’ geometric features. In this phase, the teacher’s role is minimal, reduced to assisting students to use accurate language as they communicate their beliefs. The penultimate phase of *free orientation* allows students to encounter complex tasks pertaining to the shape (i.e., open-ended tasks with many steps or several ways of completing them). This phase consolidates and extends students’ learning. The goal of the final phase of *free integration* involves students forming new understandings by reviewing and summarising what they have learnt. Completing this phase signals that students have obtained a new level of thought. Similar to Vygotsky’s sociocultural approach, Van Hiele acknowledged the importance of scaffolded learning experiences to support students’ cognitive development.

### **2.2.3.2 Critique of Van Hiele’s model**

While some researchers agree that there are some hierarchical levels of geometric thinking (e.g., Ng & Sinclair, 2015), others suggest that Van Hiele’s model may not provide a full picture of students’ development (Battista, 2007; Clements, Swaminathan, Hannibal, & Sarama, 1999). Clements et al.’s (1999) study alluded to the existence of an additional level before *visual* (level 1), which they termed *pre-cognitive*. Battista (2007) made refinements to Van Hiele’s levels by creating sub-levels within level 2. By comparison, Gutierrez, Jaime, and Fortuny’s (1991) study with Year 9 students (aged 13–15) suggested that students could possibly exist in two consecutive levels at the same time. Furthermore, with recent advancements in technology, Ng and Sinclair’s (2015) study attempted to modify Van Hiele’s model to focus on a more language based, dialogical component of student learning. While the participants in this study in Dynamic Geometry Environments (DGEs) were Year 1–3 students (5- to 8-year-olds), further studies in the early years are required, as our understanding of the influence virtual manipulatives have on the development of young students’ spatial thinking is limited.

Another criticism of Van Hiele’s model is that it neglects the known complexities and malleability of spatial thinking, as Van Hiele identified these levels within the context of two-

dimensional shapes. While Gutierrez's (1992) teaching experiment with 12-year-olds attempted to extend Van Hiele's model to include three-dimensional objects and Pittalis and Christou's (2010) study with 10- to 14-year-olds described and analysed the structure of three-dimensional geometry thinking, research on three-dimensional objects in the early years is minimal and an area yet to be fully investigated.

Overall, while Van Hiele's levels are useful descriptions of students' geometric concept development, the model lacks reflection on the progression of students' mental representations in their spatial thinking (Jones, 2002). Furthermore, studies into the influence of technology and the role of representations on Van Hiele's developmental model are limited. Thus, further exploration is required to fully understand (a) how students form mental representations, and transfer between external representations and their own internal, idiosyncratic representations; and (b) how different types of representations influence the teaching and learning of spatial thinking, particularly in the contexts situated in the early years. This present study attempts to begin addressing these gaps by examining the influence different representations have on (a) the progression of young students' spatial thinking, and (b) the teaching of spatial thinking in the early years.

## **2.3 STUDENT DIFFICULTIES WITH SPATIAL THINKING**

In the literature, two areas of concern in young students' spatial thinking are identified: (a) the difficulties students experience with the external representations (i.e., mathematical representations/manipulatives) used to explore their spatial thinking, and (b) the mathematical language used to communicate this thinking. In this section, these two areas of concern are examined and implications for further research pertaining to the teaching and learning of spatial thinking are delineated.

### **2.3.1 Student difficulties with representations**

Representations are fundamental to the teaching, learning and communication of mathematics as they allow students to organise and understand abstract mathematical thoughts (Kilpatrick et al., 2001; NCTM, 2000). For the purposes of this study, representations are focused on the external representations used to represent mathematical concepts. It is argued that spatial concepts are nothing but representations of abstract concepts (e.g., a geometrical figure acts as a representation of the abstract concept of a triangle; Duval, 1999). Thus, it is believed to be impossible to teach spatial thinking without the use of representations (Dindyal, 2015). The use of representation in mathematics teaching and learning includes the use of

language, non-spoken representations like gestures (Flevaris & Perry, 2001), symbols (e.g., objects) and figures (Duval, 1999).

Students commonly experience four main difficulties in relation to representations and spatial thinking. First, they struggle with transferring between different representations of two-dimensional shapes and three-dimensional objects (e.g., Battista & Clements, 1996; Toptas, Celik, & Karaca, 2012). Battista and Clements (1996) reported that elementary students (aged 8–11 years) were unable to coordinate the different orthographical views (i.e., a visual means of representing a three-dimensional object in two dimensions) of a cube's configuration. These students also struggled to understand and present two-dimensional representations of three-dimensional buildings and could not appreciate the interrelationship between two-dimensional shapes and three-dimensional objects (Battista & Clements, 1996). This is a concern as the teaching and learning of spatial skills often involves the use of physical manipulatives (i.e., three-dimensional representations), whereas the assessment of these skills commonly entails test items where three-dimensional objects are presented in a flat, two-dimensional format (e.g., NAPLAN, PISA, TIMSS). Within a local context, this essential visualisation skill of transformation was noted as an area of concern for Queensland Year 3 students (aged 8–9 years) on NAPLAN (Klinken, 2010). While students have trouble with visually transforming between different representations, some researchers (e.g., Toptas et al., 2012) have claimed that using dynamic, virtual manipulatives has the potential to assist older students in developing this visualisation skill. For example, Toptas et al. (2012) study consisting of eighty-two 14-year-old students found that a 3D modelling program that assisted students in folding and unfolding 3D objects had a positive effect on their spatial thinking, and improved their visualisation skills. The success of such an approach (i.e., using virtual manipulatives) for younger students is still only in early stages of exploration.

Second, students (from a study with 172 students aged 9–10) struggle with interpreting visual representations used in mathematics in general (Lowrie & Diezmann, 2007). Mathematics is a highly visual activity, which relies on graphical representations (e.g., diagrams, charts, graphs, tables of values) to convey quantitative, ordinal and nominal information. These graphics are elements of perception (Mackinlay, 1999), which include position, slope, length, area, volume, density, and hue (Cleveland & McGill, 1984). The use of visual representations, therefore, involves the ability to decode and encode from these graphics the mathematical information that they represent (Baker, Corbett, & Koedinger, 2001; Diezmann, 2004). However, students experience difficulties in interpreting graphical representations used in mathematics. Furthermore, data from the National Assessment of

Educational Progress (NAEP) in the United States revealed that Year 4 students (aged 9–10 years) experienced difficulties in reasoning and decoding bar graphs (visual representation), as well as finding the distance between two points by using a scale (National Centre for Education Statistics, 2013). Lowrie and Diezmann (2007) found that this age group of students (aged 9–10 years) in Australia also had difficulties with decoding graphics, especially when transforming shapes (i.e., reflecting, rotating and translating shapes). The ability to decode relies on spatial thinking skills (i.e., orientation and visualisation), and thus is crucial for interpreting visual representations (i.e., information represented in a visual-spatial format; Frank, 2005).

Third, young students (aged 4–6 years) experience difficulties with linking physical representations to abstract ideas (Clements, 1999), and Year 6 students (a study of 1187 students aged 10–11 years) have difficulties visually processing representations used in teaching (Ho & Logan, 2013). For example, in Clements' (1999) study conducted with 4- to 6-year-old students, many students failed to realise that a particular scalene triangle (i.e., a non-right-angled triangle with sides of different lengths) was as legitimate as an equilateral triangle (i.e., a triangle with all three sides of the same length). In addition, Clements et al. (1999) found that young students (aged 3 to 6 years), when describing irregular shapes, were more likely to rely on the shapes' visual characteristics rather than focusing on the shapes' properties. Furthermore, middle school students (aged 12–15 years) displayed similar difficulties when coordinating verbal descriptions and written definitions, as they were said to rely on prototypical images (the most commonly used image to represent the shape) when identifying shapes (Clements & Battista, 1992). For example, the prototypical image of a triangle for many is an equilateral triangle, with the base horizontal and parallel to the bottom of the page. Therefore, it has been suggested that using many different examples and non-examples of a concept helps students focus their attention on the critical attributes that define the concept (Clements, 1999), and assists students to formulate deeper understandings of the concept. Some studies have started to address prototypical thinking by investigating the use of dynamic geometry software in assisting older students' development of spatial thinking (e.g., Kaur, 2015).

The final difficulty students experience pertains to the representations used in developing spatial orientation skills. Many 11-year-old students recognise similarities between features seen on aerial photographs to large-scale plans of the same area (Boardman, 1990). However, young students (aged 4–7 years) often struggle with linking concrete and abstract “frames of reference” (Clements, 1999). They struggle to separate the spatial relations from the immediate environment and have difficulty conveying the visual imagining that is actually there



(Clements, 1999). This illustrates the importance of (a) the choice of representations in developing spatial concepts, and (b) students' ability to transfer knowledge gained from external representations to their internal frames of reference.

### **2.3.2 Student difficulties with mathematical language**

Linguistics structures of mathematical language have proven to be difficult for many young students (e.g., Pimm, 1987). How language is used on a daily basis differs from how mathematical language is used in mathematics lessons (Gough, 2007; Schleppegrell, 2007). The language of mathematics consists of technical vocabulary (e.g., rotation, reflection, degrees) and everyday words that have a particular meaning in mathematics (e.g., place, position and faces). Schleppegrell (2007) suggested it may be more confusing for students to learn the technical mathematical meaning of everyday words than learning entirely new mathematical vocabulary. This problem continues into tertiary education. MacGregor's (2002) study with pre-service teachers found that when mathematics concepts were constructed in everyday language, pre-service teachers' mathematical understanding was often technically incorrect. Furthermore, young students exhibit language difficulties when expressing the reasons behind their spatial thinking (see Clements et al., 1999, where young students, aged 3–6, could not explain their accurate selection of shapes). A suggested solution to this problem is to use increased spatial vocabulary to assist students' engagement in discursive justification of their spatial thinking (Hallowell, Okamoto, Romo, & La Joy, 2015).

This problem with everyday versus technical language appears to be exacerbated within disadvantaged contexts, where English is often not students' first language (Adoniou & Qing, 2014; Barton, Chan, King, Neville-Barton, & Sneddon, 2005; Riordain & O'Donoghue, 2009). Abedi and Lord (2001) found that "English language learners scored lower on standardised tests of mathematics than students who are proficient in English" (p. 219). These challenges related more to language than to students' mathematical skill, as these students performed "10% to 30% worse on arithmetic word problems than on comparable problems presented in numeric format" (Abedi & Lord, 2001, p. 219). These language problems are of concern, as research findings have indicated there is a positive correlation between language proficiency and mathematics achievement levels (Pierce & Fontaine, 2009; J. Miller & Warren, 2014; Warren & Miller, 2013).

Therefore, the challenge for teachers of mathematics is to translate back and forth between technical and everyday language (Lemke, 2003; J. Miller & Warren, 2014; Warren & Miller, 2013) to foster students' communicational skills. For this to occur, current

understandings of language issues in mathematical education need to go beyond a focus on vocabulary or the grammatical patterns of language to include all aspects of communication, such as the use of representations and gestures (J. Miller, 2014). An implication from these findings is a need for better articulation of *what* should be taught and *why* (Sinclair & Bruce, 2015).

In summary, to date limited emphasis has been placed on teaching of spatial thinking in the classroom (Lowrie et al., 2017), and particularly the early years classroom (Bruce, Moss, & Ross, 2012; Clements & Sarama, 2011; Stipek, 2013). While some studies have raised concerns about the limited use of resources in the teaching of spatial thinking (Clements & Sarama, 2011; Clements, Sarama, & DiBiase, 2004; Ehrlich, Levine, & Goldin-Meadow, 2006) and the role of newer technologies in creating helpful representations (Battista, 2007; Ng & Sinclair, 2015), generally the role of representations in the learning and teaching of spatial thinking warrants further investigation. This present study attempts to address these lacunas, by examining the role of representations in the learning and teaching of spatial thinking of young students.

## **2.4 REPRESENTATIONS**

In mathematics education, representations have a dual purpose. Representations form part of the language of mathematics (i.e., a medium for expressing one's thinking), and their use contributes to the process of illuminating ideas (i.e., acting as a tool for thinking; Coulombe & Berenson, 2001; Diezmann & McCosker, 2011; NCTM, 2000). This dual purpose allows representations to be both a process (the act of thinking) and a product (a visual, verbal or even kinaesthetic way of representing some concept; Fennel & Rowan, 2001). Therefore, the use of representations constitutes an important dimension of both the teaching and the learning of mathematics.

In regard to students' learning, representations are classified as either *internal* or *external* (Goldin, 2003). Representations that exist within the student's mind (e.g., mental images and models) are referred to as internal, while representations found in the outside environment (e.g., a computer screen, a piece of paper or physical manipulatives) are considered external. The following sections examine the literature pertaining to internal and external representations in relation to mathematics teaching and learning.

### **2.4.1 Internal representations**

Internal representations consist of imagined aspects (e.g., sensations, perceptions, or even emotional feelings) that are closely related to prior experiences (Goldin, 2003). In other words,

internal representations in mathematics act as “abstractions of mathematical ideas or cognitive schemata that are developed by a learner through experience” (Pape & Tchoshanov, 2001, p. 119). They do not just suddenly appear in students’ minds, but are built up over time through experiences (Goldin, 1998). Thus, each student forms his or her own internal representational system.

The development of internal representations occurs through visual imagery, spatial, tactile, and kinaesthetic representations (Garrett, 2010), as these cognitive schemata are made abstract within the student’s mind (Miura, 2001; Pape & Tchoshanov, 2001). This internal process, where students assign meaning to their ideas (Goldin & Shteingold, 2001), allows students to make sense of mathematical concepts from the external stimulus (either verbal, visual, or kinaesthetic) received during mathematics lessons. Therefore, the foundation of mathematics learning lies in the representations that we internalise (Dehaene, 1997). Students’ self-created, idiosyncratic representations give teachers a “window” into their mathematical thinking (Diezmann & McCosker, 2011).

#### **2.4.2 External representations**

External representations help us to understand mathematical concepts (Janvier, Girardon, & Morand, 1993), and in some instances can also be defined as “the act of externalizing an internal, mental abstraction” (Pape & Tchoshanov, 2001, p. 119). These stimuli are structurally equivalent presentations of given mathematical concepts (e.g., pictures, symbols and signs; Pape & Tchoshanov, 2001) and, in whatever medium, are interactive (Goldin & Kaput, 1996). External from the learner, these mathematical representations include physical, embodied, observable configurations, and traditional representations (e.g., graphs, number lines; Goldin & Kaput, 1996). While most external representations are considered as a physical form, the language and linguistic features used by teachers and students to assist in explaining and sharing the mathematical ideas are embedded in these representations (Goldin & Kaput, 1996; Pape & Tchoshanov, 2001). Therefore, from a sociocultural perspective, language as a form of discourse is an external representation that plays a vital role in students’ learning.

One theory states that student learning progresses through three levels of engagement with external representations (Bruner, 1966). Young students learn through manipulations (enactive representation) where concepts are modelled (first level); while older students learn through perceptual organisation and imagery (iconic representation), at a semi-concrete level (second level). Eventually, adolescents use language and symbolic thought to assist their learning (symbolic representation; third level). Although this notion of progression through

stages has existed for some time (e.g., Piaget & Inhelder, 1967; Vygotsky, 1978), Bruner's (1966) research has been contested by some researchers (e.g., Goldin & Shteingold, 2001; Kaput, 1992; Lowrie, Logan, & Scriven, 2012) who have suggested that all three representations (enactive, iconic, and symbolic) should be used in parallel rather than sequentially to support and enhance students' learning.

### **2.4.3 Student learning involves transference between internal and external representations**

Internal and external representations have a complementary relationship (Goldin 2003; Goldin & Kaput, 1996; Golding & Shteingold, 2001). Students create mental images (internal) of mathematical relationships described by the teacher (external), and use external representations to communicate their mathematical ideas (Siemon et al., 2011). At times, these external representations may be student generated, personal and nonstandard (Izsak & Sherin, 2003). Linking internal and external representational systems “enables us to see complex ideas in a new way and apply them more effectively” (Kaput, 1998, p. 180).

To understand the complexity of how representational systems interact with each other, Goldin and Janvier (1998) reorganised internal and external representations into four broad categories: *embodied representations* – external features including physical situations in the environment; *linguistic representations* – syntax and semantics associated with these external representations; *formal systems* – the use of symbols and definitions; and, finally, *internal individual systems* – the thinking process, including affect principles such as motivation. In addition, Vygotsky (1978) saw language as essential to the construction of meaning, and due to its complex nature, language can be viewed as both an internal and external representation. Students' self-talk while working gives insight into their internal thought processes, just as scribbles and working on paper do.

Students' success in learning involves forming effective connections between internal and external representations (Goldin & Kaput, 1996; Pape & Tchoshanov, 2001). Through this process, abstract ideas can become concrete and physical objects assist understanding of the abstract (Basson, Krantz, & Thornton, 2006; Bills & Gray, 1999). From a sociocultural perspective, this process entails teacher and student interaction to co-construct meaning through scaffolded work with manipulatives. Therefore, improvement in mathematics learning involves teachers making connections between students' idiosyncratic, internal representations and the discipline-valued standard representations that are commonly used in mathematics classrooms

(Smith, 2003). It is the ability to transfer between different representations that strengthens conceptual understanding (Duval, 2000).

#### **2.4.4 Manipulatives**

Within the context of a classroom, manipulatives are a form of external representation that act as tools for learning. It is purported that manipulatives allow teachers to help students construct deeper understanding by making connections to real-life experiences (Uribe-Florez & Wilkins, 2010). These connections to real-life experiences further assist students by fostering their development of internal representations. Comparative studies on manipulative use found that young students who used manipulatives (a) outperformed those who did not (4- to 7-year-olds; Clements, 1999); (b) gained more understanding (10- to 11-year-olds; Moch, 2001); and (c) demonstrated higher performance in spatial ability tests (8- to 11-year-olds; Bishop, 1973). While the use of manipulatives is documented as positively influencing young students' spatial learning (e.g., Bishop, 1973), little is known with regard to the influence different types of manipulatives have on the teaching and learning process.

The two most commonly explored manipulatives in current research are physical manipulatives (PM) and virtual manipulatives (VM). While researchers advocate for the integration of both PM and VM into elementary mathematics classrooms (e.g., Rosen & Hoffman, 2009), there is a paucity of comparative studies between PM and VM within mathematics educational literature.

##### ***2.4.4.1 Physical manipulatives***

Physical manipulatives (PM) are hands-on objects that rely heavily on visual and kinaesthetic (tactile) learning and have various advantages and disadvantages within the mathematics classroom context. Vygotsky (1978) noted the importance of physical manipulatives and imaginative play, stating that the external world is transformed into internalised language during play. Some other positive influences on student learning attributed to PM include:

- gains in students' mathematical ability (Clements, 1999; Cuoco & Curcio, 2001; Goldin, 2003; Goldin & Shteingold, 2001; Heritage & Niemi, 2006; Kilpatrick et al., 2001; Presmeg, 1999; Warren & Miller, 2013, 2016), such as increased development and creation of internal representations (Heddens, 1997), and scaffolding young students' (10-year-olds) understanding towards abstract expression (Warren, 2006);

- increased student engagement (Siemon et al., 2011) and increased student confidence (Bandura, 1997; Riconscente, 2013), which resulted in greater learning; and
- improvements in students' communication and socialisation (Heddens, 1997) by assisting students' thinking, explaining and justification of arguments (Greeno & Hall, 1997; Pape & Tchoshanov, 2001), or by acting as a medium for students to demonstrate their understanding (Heritage & Niemi, 2006).

While most research findings have evidenced the positive outcomes of PM use, several limitations have been raised. For example, the resultant increased time required for mathematics lessons (e.g., distribution of resources and behaviour management) and the requisite motor skills needed for students to successfully manipulate hands-on material have been cited as concerns (Siemon et al., 2010).

Furthermore, few studies have explored their effectiveness within disadvantaged contexts. Recently, Warren and Miller (2013, 2016) explored PM use with young Indigenous Australian students. Findings from this study indicated that the use of manipulatives with a variety of representations influenced gains in Indigenous Australian students' engagement in mathematical learning and their levels of mathematical achievement. However, research has yet to validate these gains with different groups of educationally disadvantaged students. Furthermore, understanding how and why these manipulatives influence students' learning and the effect different types of manipulatives (e.g., PM and VM) have on the teaching and learning of spatial thinking requires further investigation.

#### ***2.4.4.2 Virtual manipulatives***

Virtual manipulatives (VM) are dynamic representations of physical materials that can still be manipulated. Moyer, Bolyard, and Spikell (2002) described VM as “an interactive, Web-based visual representation of a dynamic object that presents opportunities for constructing mathematical knowledge” (p. 373). The designs of many VM are based on existing PM (Moyer-Packham & Suh, 2011). The use of digital technology has also resulted in traditional external representation systems becoming dynamic (Kaput, 1989). Therefore, VM are doing more than just representing objects; they allow students to observe transformations of objects as they occur. This type of technology is purported to have transformed mathematics learning (Moreno-Armella, Hegedus, & Kaput, 2008) by allowing students to interact with each other as they share and manipulate these dynamic representations. However, evaluation of how these manipulatives can support student learning is often outpaced by innovation in newer technology (Earnst, 2013; Epper & Baker, 2009). Kaput (1992) described this conundrum as, “Anyone who

presumes to describe the roles of technology in mathematics education faces challenges akin to describing a newly active volcano – the mathematical mountain is changing before our eyes ...” (p. 515).

Several benefits have been identified related to the use of VM for mathematics learning (Hitchcock & Noonan, 2000; Reimer & Moyer, 2005; Suh, Moyer, & Heo, 2005; Yelland, 1999). Some positive influences on student learning include:

- resulting in greater mathematical progress compared to students who used paper and pencil, or static textbook diagrams (Hitchcock & Noonan, 2000);
- promoting problem-solving skills which facilitate changes in students’ mental representations (Yelland, 1999);
- providing unique learning opportunities that allow students to organise and model mathematical situations (Orrill & Polly, 2013), create complex spatial patterns (Moyer, Niezgod, & Stanley, 2005), creatively problem solve, transform shapes, participate in self-guided instruction (Clements & Sarama, 2002), and use more precise transformations (Highfield & Mulligan, 2007);
- assisting in understanding abstract concepts (Moyer, Salkind, & Bolyard, 2008);
- increasing engagement (Attard & Curry, 2012; Murray, 2010; Verenikina & Kervin, 2011) and self-efficacy (Riconscente, 2013); and
- increasing students’ talk (Clements & Sarama, 2014), especially student to student dialogue (Abdu, Schwarz, & Mavrikis, 2015).

Recently, with current advances in digital technologies, there has been an increased focus on the influence of VM use in spatial thinking. Unlike older software (e.g., Logo-based programming), which challenges students’ dexterity with mouse use or keyboard controls, VM (e.g., touchscreens) have created multi-touch environments that improve students’ mathematical discourse (Sinclair & Bruce, 2015). These newer digital technologies promote interactions between visual and kinaesthetic learning, which have been shown to support the teaching and learning of spatial thinking (Battista, 2008; Bruce, McPherson, Sabeti, & Flynn, 2011; Clements & Sarama, 2011; Highfield & Mulligan, 2007; Jorgensen & Lowrie, 2012; Sinclair, de Freitas, & Ferrara, 2013; Sinclair & Moss, 2012). Therefore, some benefits of using VM are embedded within the unique features of the software (or applications). These unique features have been purported to provide students with feedback and improve student exploration of mathematical concepts (Chase & Abrahamson, 2015; Dove & Hollenbrand, 2014; Kazak, Wegerif, & Fujita, 2015). These unique features include:

- *direct real-time feedback* (Leichtenstern, André, & Vogt, 2007), which allows scaffolding of learning to occur automatically (e.g., programs make shapes go transparent so children can see the outline of a puzzle underneath them), automating lower level scaffolding tasks, and allowing students to spend more time on activities that require and stimulate higher order thinking, thus minimising students' "time-on-task" (Dricky, 2000); and
- *the multi-representational dimension* (simultaneously seeing multiple representations) of VM (Alagic & Palenz, 2006; Hennessy et al., 2001; Mayer, 2002; Stylianou, Smith, & Kaput, 2005; Suh et al., 2005; Zbiek, Heid, Blume, & Dick, 2007), where gains are theorised to be influenced by dual coding (Mayer, 2002; Mayer & Anderson, 1991; Mayer & Morcho, 1998; Mayer & Sims, 1994; Sinclair & Yerushalmy, 2016).

Dual coding is based on Paivio's (1986) assumption that information processing occurs in two corresponding channels: a visual channel and an auditory channel. This theory states that students' cognitive processing requires them to build connections between the two processing systems that humans possess (i.e., using pictorial and verbal material). "People learn more deeply from words and pictures than from words alone" (Mayer, 2005, p. 47). Dual coding is also purported to overcome the limitations of human working memory and promote higher cognitive processes (Farah, Hammond, Levine, & Calvanio, 1988; Rasmussen & Bisanz, 2005; Sweller, 1999). Therefore, it is suggested that cognitive overload in students can be avoided by using both channels (the visual/pictorial and auditory/verbal) in instruction (Mayer, 2005). This type of instruction is purported to influence the types of interactions students have with VM environments (Mayer & Anderson, 1992; Pyke, 2003; Sweller, 2003). However, these claims need further investigation in the early years context.

Recently, a type of VM that has begun to gain attention is the Dynamic Geometry Environment (DGE). The use of DGE has been found to support students' shift from solely using spatio-graphical information to applying a more theoretical understanding to their spatial thinking, and to attend to the properties that remain unchanged in the dynamic diagrams used (Battista, 2008; Kaur, 2015; Ng & Sinclair, 2015; Sinclair & Moss, 2012). While the majority of studies have examined DGE in secondary contexts (e.g., Battista, 2008; Kaur, 2015), Sinclair & Moss's (2012) study with young students (aged 4 and 5) found that students using DGE quickly moved beyond the use of prototypical images of triangles, a concept that has been found to be challenging for students (Clements & Battista, 1992; Hershkowitz, 1989). Battista (2008) attributed the effectiveness of DGEs to the embodied action of dragging, where students notice invariance (e.g., in the program *ShapeMaker* as a student dragged the rhombus maker, they



noticed the four sides remained equal). Thus, the effectiveness of embodied action, especially in other software platforms, requires further investigation.

With the ever-changing nature of newer digital technologies, assumptions about what spatial thinking skills can be learnt through the use of VM within early years classrooms are being challenged. While previous research acknowledges that potential benefits of VM may be dependent on the teacher's ability to make explicit connections between multiple representations (Moyer, Salkind, & Bolyard, 2008; Reimer & Moyer, 2005), there is a gap in the literature with regard to how teachers can best support the use of VM in classrooms (Polly, McGee, & Martin, 2010), particularly in the early years. To this end, there is a need to examine the role of the teacher in VM use in mathematics classrooms (Polly, 2014) and their subsequent influence on student learning. Not only are further studies required with respect to the influences of VM on young students' learning, but also these possible benefits need to be compared to the influence of PM on young students' learning.

#### ***2.4.4.3 Comparison of physical and virtual manipulatives***

Past comparative studies on the influences of PM or VM on students' learning have produced varied results. A study by Brown (2007) found that while manipulatives, both virtual and physical, enhanced the learning environment of forty-nine American students in a Year 6 mathematics classroom, students (aged 11–12 years) taught equivalent fractions using PM outperformed students who used VM. However, Brown (2007) also noted that VM were more engaging for students and resulted in an increase in their time on task. Steffe and Wiegel's (1994) case study on two third grade students (aged 8–9 years) also acknowledged that the dynamic aspect of VM engaged children in mathematical play more than PM or paper media did. By contrast, Suh's (2005) PhD dissertation, examining thirty-six American third graders' (8- and 9-year-olds) mathematics achievement and representation preferences (VM or PM) for adding fractions and balancing equations, found that students from the VM class outperformed students from the PM class.

The debate with regard to when to use PM and VM is ongoing. Hunt, Nipper, and Nash's (2011) study on seventy-eight American middle graders (aged 8–12) recommended, "using concrete [physical], followed by virtual manipulatives. Once conceptual understanding is effective with concrete [physical] manipulatives the subsequent use of virtual manipulatives seems to facilitate bridging to the abstract" (p. 6). In contrast, studies by Thompson and Thompson (1990) on fourth graders (aged 9–10 years) and Clements (1999) with children aged 3–6 suggested that simultaneous use of both PM and VM offered connections between the

concrete and abstract; however, this was dependent on proper guidance. An explanation given for these diverse results is that PM are “multisensory (i.e., they can be seen, smelt, moved, picked up, touched, weighed)”, whereas VM are “bisensory (seen and moved)” (Proctor, Baturo, & Cooper, 2002, p. 3). Therefore, VM are considered to be more abstract. It is hypothesised that while more detailed memory structures (schema) may be developed by PM than VM, mathematising (i.e., the refinement and abstraction of ideas and concepts) may require VM to facilitate the process (Proctor et al., 2002). In addition, VM students are deprived of the tactile experience that is available to students using PM (Olkum, 2003). Lowrie (2002b) warned about the abstract nature of VM in developing young students’ spatial thinking by stating that “... it may be more worthwhile to encourage young children to develop important foundation understandings away from computer-based environments or provide learning experiences on the computer that challenge children to consider links between 3D, simulated 3D and 2D worlds” (p. 445).

#### ***2.4.4.4 Concluding comments***

Previous research on manipulative use (both physical and virtual) in mathematics education has yielded positive results with regard to student learning (Clements, 1999; Heddens, 1997; Highfield & Mulligan, 2007; Riconscente, 2013; Siemon et al., 2011; Warren, 2006; Warren & Miller, 2013). However, results from comparative studies between PM and VM have been varied (e.g., Brown, 2007; Olkum, 2003; Suh, 2005). Furthermore, there is a lack of studies situated within an Australian context. The aim of the study is to explore the use of representations (i.e., PM and VM) in the teaching and learning process and their influence on Year 3 students (aged 8–9 years). Additionally, even though researchers comment on the inseparability of teaching and learning (e.g., Lerman, 2001; Roth & Radford, 2011; Sfard & McClain, 2002), there is a lacuna in the literature that examines both the teaching and the learning aspects of spatial thinking simultaneously.

## **2.5 RESEARCH QUESTIONS**

Previous research suggests spatial thinking is fundamental to mathematics learning (Bronowski, 1947; Clements & Sarama, 2007, 2011), and acts as a predictor for future mathematical achievement levels (Battista, 1990; Gunderson et al., 2012). However, research with regard to spatial thinking is almost non-existent in early years mathematics classrooms (Sarama & Clements, 2009, 2011; Newcombe & Frick, 2010), and how to teach it in these contexts has received little attention. While Van Hiele’s (1986) model for development of geometric thought provides levels and characteristics of these levels, and acknowledges the

teaching aspect through the phases of learning, criticisms are raised due to its lack of attention to (a) the development of spatial thinking with regard to three-dimensional objects (Gutierrez, 1992; Pittalis & Christou, 2010); and (b) how different types of representations can influence this development (Ng & Sinclair, 2015).

Furthermore, with recent advancements in technology, there is a lack of attention to the influence that technological representations have on both the learning and the teaching of spatial thinking. Additionally, comparative studies with regard to the benefits of PM as compared to VM in early years classrooms are almost non-existent. Therefore, the influences of these representations on both the teaching and the learning of spatial thinking in the early years classroom are the focal point of this research. The questions guiding this study are:

1. *What influence do different external representations (e.g., PM and VM) have on young students' learning of spatial thinking?*
2. *What changes occur in the teaching and learning of spatial thinking when using different external representations (e.g., PM and VM)?*

When exploring the use of external representations (i.e., manipulatives) in teaching and learning, a major consideration is that this process involves interactions between teachers and students, which are social and cultural acts. Therefore, a robust examination of the influences external representations (PM and VM) have on the teaching and learning of spatial thinking requires the use of a sociocultural lens. This perspective provides the theoretical framework for this present study. In the next section, Vygotsky's contribution to a sociocultural perspective, and applications of this perspective via two analytical approaches (i.e., one for teaching and one for learning) are delineated.

## **2.6 VYGOTSKY'S SOCIOCULTURAL THEORY AS A THEORETICAL FRAMEWORK**

The theoretical framework for this study is based on Vygotsky's sociocultural theory. Sociocultural theory addresses concerns with regard to Piaget's lack of emphasis on the social context in which learning occurs. As Palincsar (2005) stated, learning is more successful when it draws on the collective group, rather than working in isolation. In sociocultural learning theory, "rather than being an acquirer of goods, the learner is now seen as a beginning practitioner trying to gain access to a well-defined, historically established form of human doing" (Sfard, 2008, p. 78). From a sociocultural perspective, learning begins on a social plane and is therefore considered a social act. Meaning is constructed through cultural tools: sign systems, such as the language found in discourse and interactions, and signs developed through

physical artefacts, such as mathematical representations (Vygotsky, 1978, 1986). Through the use of cultural tools and various social interactions, students become aware of their own thoughts and can make changes to their existing mental structures by amplification (i.e., using a tool to provide a more efficient way of completing a task) or by cognitive reorganisation (i.e., changing the way a student thinks about an idea or approaches a task). Therefore, use of cultural and physical tools develops in students new modes of reasoning and go beyond just mastery of the tools. While Vygotsky's original work was based on parent–child interactions, Cazden (1979) extended it to include classroom teacher–student interactions. As a result, effective teacher–student interactions are considered as a primary objective for learning (Sfard, 1998). The relationship between teacher and students, acting as co-participants within the social act of learning, needs careful consideration.

This study is grounded in the idea that students' interactions with others and the practices they actively engage with in the mathematical classroom influence the development of their spatial thinking. Therefore, a sociocultural perspective provides the overarching theoretical framework for this study. Additionally, mediated activity and the use of tools, such as physical artefacts (e.g., mathematical representations), and signs, such as symbol systems (e.g., language) are necessary for thinking and learning (Vygotsky, 1978). As this study explores students' spatial thinking through their interactions with manipulatives (i.e., representations) and their communication within a mathematical community, Vygotsky's theory provides the theoretical tools for researchers to interpret the social and cultural dimensions of students' thinking and learning (Walshaw, 2016).

## **2.6.1 Fundamental concepts in Vygotsky's theory**

Several concepts are fundamental to Vygotsky's theory. These include *internalisation*, *mediation* and the use of cultural tools, the *Zone of Proximal Development* (ZPD, which is often used in association with the term *scaffolding*), and the *interrelationship of thought and language*.

### **2.6.1.1 Internalisation**

Internalisation is a process where students use appropriation of modes of meaning making that are acceptable within specific social contexts (e.g., the mathematics classroom) in order to take control over external processes. It is a process in which students learn how to use cultural tools through practices with these tools. In other words, learning is not just a process of assimilation or transferring social activity onto an individual plane but requires students' reflective "independent critical appreciation and interrogation of mathematical concepts"

(Walshaw, 2016, p. 18). In this process of internalisation, students use cultural tools (e.g., the language, gestures) modelled by the “more knowledgeable other” (or expert). The expert’s use of the cultural tools becomes the “tradition of thought” (Walshaw, 2016, p. 18), which is offered for students to learn through modelled social practices. Previous studies (e.g., Goos, Galbraith, Renshaw, & Geiger, 2003) have also shown that students can work with peers of complementary (i.e., similar levels of) expertise to move forward within their ZPD. When students adopt these social practices, and use these cultural tools, they are becoming aware of their own thoughts (Walshaw, 2016). Sometimes *appropriation* occurs, where students take up this “tradition of thought” in their own unique ways. *Appropriation* evidences students’ critical reflection on and extension of the learnt “tradition of thought” (Walshaw, 2016, p. 18). Vygotsky argued that this process of internalisation, including students’ being able to critically reflect on learnt social practices, is a key goal in education and stated that,

... it is not so important to teach a certain quantity of knowledge, as it is to inculcate the ability to acquire such knowledge and to make use of it ... Where he [the teacher] acts like a simple pump, filling students with knowledge, there he can be replaced with no trouble at all by a textbook, by a dictionary, by a map, by a nature walk ... Where he is simply setting forth ready-prepared bits and pieces of knowledge, there he has ceased to be a teacher. (Vygotsky, 1997, p. 339)

To achieve internalisation, Vygotsky (1978) believed that ascertainment of higher mental functions also required the use of tools. Similar to a process where physical tools extend our physical abilities, Vygotsky’s notion of mental tools to extend our mental abilities enables students to solve problems and create solutions. Thus, the use of mental tools (e.g., independence, critical appreciation or interrogation tools) displays students’ progression towards internalisation.

### **2.6.1.2 Mediation**

Sociocultural theory emphasises that not only are higher mental functions indications of moving from concrete to abstract thinking, mediated through tools (e.g., concepts, language, artefacts), but also is all learning. Through mediation and as learning increases, students master the use of tools and begin to internalise social practices (Vygotsky, 1978). However, Vygotsky (1978) believed that “more knowledgeable others” (MKOs) are required to mediate students’ understanding of the world, which includes socialisation with people and interaction with objects. Thus, learning is a collaborative and cooperative endeavour where social interactions with MKOs promote student learning (Perry & Dockett, 2007). While Vygotsky’s parental role of MKO was extended by Cazden (1979) to include teachers, more recently, in contexts with

small groups and whole classes of learners, Goos (2004) argued the possibility of peers with complementary expertise acting as an MKO. Goos suggested: “there is learning potential in peer groups where students have incomplete but relatively equal expertise, each partner possessing some knowledge and skill but requiring the others’ contribution in order to make progress” (p. 263). However, student–student interactions in spatial thinking, especially with VM use, are still an under-researched area in an early years classroom context. Within the context of this present study the teacher acts as the external mediating agent for students. Mediation links to the concept of internalisation because, over time, as students begin to independently initiate their use of cultural tools, the role of the teacher minimises. The role of the teacher as MKO in the concept of mediation is essential in understanding Vygotsky’s concept of ZPD. By examining the study through a sociocultural perspective, interactions between all communicators can also be examined.

### ***2.6.1.3 The Zone of Proximal Development (ZPD)***

A student’s ZPD is termed by Vygotsky (1978) as “the distance between the actual development level as determined by independent problem solving and the level of potential development as determined through problem solving under adult guidance or in collaboration with more capable peers” (p. 86).

Within the ZPD both teachers and students have significant roles to play. First, the concept of ZPD postulates that students’ active participation in learning is essential. “The most powerful mathematics for a pre-schooler is usually not acquired while sitting down in a group lesson but is brought forth by the teacher from the student’s own self-directed, intrinsically motivated activity” (Clements, 2001, p. 274). Second, intervention from an MKO is essential in providing guidance to students with regard to the social practices and cultural tools used within the mathematics community. Cultural tools frame the social practice that occurs. Through ZPD, Vygotsky highlighted the importance of the role of the MKO, which emphasises a collaborative view of the teacher as a participant in the learning process instead of previous acquisitionist views (e.g., the teacher acts as the giver of knowledge and students as receivers of knowledge). Due to the importance placed on the role of the MKO in ZPD, concepts of ZPD form the foundation for pedagogical practices that emphasise the importance of interactions in the classroom (Driver, Asoko, Leach, Mortimer, & Scott, 1994; Sfard, 2008).

### ***2.6.1.4 The interrelationship of thought and language***

The final concept fundamental to Vygotsky’s sociocultural theory relates to the interrelationship of thought and language. In *Thinking and Speech* (Vygotsky, 1987), the

meditational role of speech was acknowledged. Vygotsky viewed speech as a cultural tool that shapes students' thoughts and actions. Only through the convergence of speech and thought is students' intellectual development progressed. In Vygotskian terms, thought refers to the development of mental concepts, while speech can represent both "inner voice" and the oral language, which is observable through communicative utterances. Vygotsky also postulates that young students often use "self-talk", initially as a tool to initiate social interactions, but eventually evolve to use it as self-regulation (i.e., inner speech). From Vygotsky's perspective, thinking can occur without language; however, higher levels of thinking are achieved when thinking is mediated by language. This is in contrast to Sfard's (2001) perspective where thinking cannot occur without language, as thinking is a communicational act that occurs with oneself.

## **2.7 APPLICATION OF VYGOTSKY'S THEORETICAL FRAMEWORK**

While the fundamental concepts of Vygotsky's sociocultural theory provide an overarching framework to encapsulate the social aspects of students' mathematical learning, more rigorous lenses are required to examine the nuances that occur within the separate teaching and learning aspects of spatial thinking. In the next sections, first, the teaching of spatial thinking is examined through the lens of scaffolding (drawn from Vygotsky's concepts of ZPD and MKO). Second, aspects of students' learning in mathematics and spatial thinking are scrutinised using Sfard's commognitive lens (drawn from Vygotsky's concepts of internalisation, mediation and the interrelationship of thought and language).

### **2.7.1 Scaffolding**

Researchers have extended the basic tenets of Vygotsky's ZPD and introduced the term *scaffolding* as the role of the MKO (e.g., Sfard, 2008; D. Wood, Bruner, & Ross, 1976). The metaphoric term of scaffolding refers to the support structures that teachers provide in assisting the development of new understandings, new concepts, and new abilities in learners (Hammond & Gibbon, 2001). This psychological idea of scaffolding, based on Vygotsky's (1978) ZPD, highlights how cultural tools and mediation from MKOs allow learners to engage in practices beyond their independent capabilities. In this role, the MKO assists students by regulating the complexity of the task to suit the needs of the student. However, the MKO does not have to be a schoolteacher, but could be a parent, other students, books or even the internet (McLeod, 2007). The relationship between scaffolding and the application of Vygotsky's concepts of ZPD and MKO are further examined in section 2.7.1.1.

Based on Vygotsky's ZPD, effective scaffolding is situated within a sociocultural paradigm and is highly contingent on learners and their progress. In the context of the mathematics classrooms, scaffolding involves "students actively construct[ing] meaning as they participate in increasingly substantial ways in re-enactment of established mathematical practices" (Cobb, Yackel, & McClain, 2002, p. 21). Stone (1993) stressed that within scaffolding, students are not passive participants, and that both teacher and student need to be active participants for the occurrence of effective scaffolding. In effective scaffolding, the amount of initial support granted and the rate at which it is withdrawn are dependent on the needs of each individual student.

### ***2.7.1.1 Importance of language in scaffolding***

Essential elements of ZPD and scaffolding are the acquisition of language and creation of productive dialogue (Cohrssen, Church, & Taylor, 2015; Prediger & Pohler, 2015; Smit, Van Eerde, & Bakker, 2013). Acknowledged as fundamental to students' cognitive growth, language provides purpose and intention so behaviours are understood (Vygotsky, 1986). Dialogue created in classroom situations allows guidance of students' disorganised and spontaneous ideas towards the more systematised and rational concepts of an MKO (Bakker, Smit, & Wegerif, 2015). The use of dialogue can range from informal, casual talk to deliberate, formal explanations. Recent research has prompted a surge in literature related to the links between scaffolding and dialogic teaching (e.g., Abdu et al., 2015; Bakker, Smit, & Wegerig, 2015; Bell & Pape, 2012; Calder, 2015; Diez-Palomar & Olive, 2015; Gonzalez & DeJarnetter, 2015; Kazak et al., 2015). Dialogic teaching entails teachers regulating their own language, scaffolding students' learning by conforming language to a student's degree of understanding, and helping students develop appropriate mathematical language. This in turn allows students to take on the role of the "primary knower" and the "sequence initiator" (Nassaji & Wells, 2000), and exchange ideas (Nystrand et al., 2003). It provides a place for students to disagree, challenge, negotiate and change their ways of thinking. Fundamentally, students become the negotiator and co-constructor of meaning making and learning (Bell & Pape, 2012).

While interactions in discourse generally involve communication between teacher and students, scaffolding is not solely restricted to verbal forms of communication. Scaffolding may also be dependent on and provided through the looks and gestures of speakers (Holton & Clarke, 2006). Though scaffolding comes in many formats (e.g., books, internet, telephone), Holton and Clarke (2006) stress the importance of face-to-face interactions. These interactions are significant as teachers can then detect and use the subtle cues found in non-verbal communication (e.g., gestures, looks, expressions) to provide appropriate scaffolding. While



most scaffolding studies focus on dialogue, some authors emphasise the importance of considering non-verbal behaviours and gestures (e.g., P. Miller, 2005). Within current scaffolding literature, there is a gap with regard to influences of the use of these non-verbal forms of communication within the spatial domain.

Not all aspects of scaffolding practices align with sociocultural theory. Wilkinson and Silliman (2000) outlined two types of scaffolding based on the social interaction patterns observed in the discourse of teaching. The first, Directive Scaffolding, refers to Initiation–Response–Evaluation (IRE) structure of discourse. Directive Scaffolding is observed in most formal classroom interactions and parallels direct instruction (Pressley & McCormick, 1995). The teacher’s primary job in Directive Scaffolding is transmitting and assessing knowledge. Within this scaffolding approach, the evaluation is exclusively the responsibility of the teacher (Silliman & Wilkinson, 1994) and primarily concerned with the teacher providing students with the answers. The second, Supportive Scaffolding, is characterised by an Initiation–Response–Follow-up (IRF) discourse structure. Supportive Scaffolding is a more contemporary, learner-centred approach to scaffolding where responsibility for learning is gradually transferred to the learner and supports are modified “in the moment”. This second approach aligns more with Vygotsky’s sociocultural theory.

### ***2.7.1.2 Establishing a lens based in scaffolding***

There are multiple different understandings of scaffolding, and due to its dynamic nature and complexity, scaffolding is a difficult construct to measure (Davis & Miyake, 2004; Granott, 2005; Renninger & Granott, 2005; Renninger, Ray, Luft, & Newton, 2005). However, while there is no generally accepted way of viewing scaffolding, Van de Pol, Volman, and Beishuizen’s (2010) meta-analysis of 66 articles related to scaffolding proposed that three characteristics are central to its definition: *contingency*, *fading*, and *transfer of responsibility*. *Contingency* is related to how the support the teacher offers must match to the current level of students’ performance. *Fading* entails the gradual withdrawal of scaffolding at a rate that is dependent upon students’ development (i.e., support is decreased over time). *Transfer of responsibility* refers to the gradual transference of responsibility for students’ performance on a task from the teacher to the learner. These three constructs are similar to those delineated by Smith et al. (2013), namely *diagnosis*, *responsiveness* and *hand over of independence*. A conceptual model illustrating the interactive process that occurs between the teacher and students and the three essential elements of scaffolding is presented in Figure 2.2.

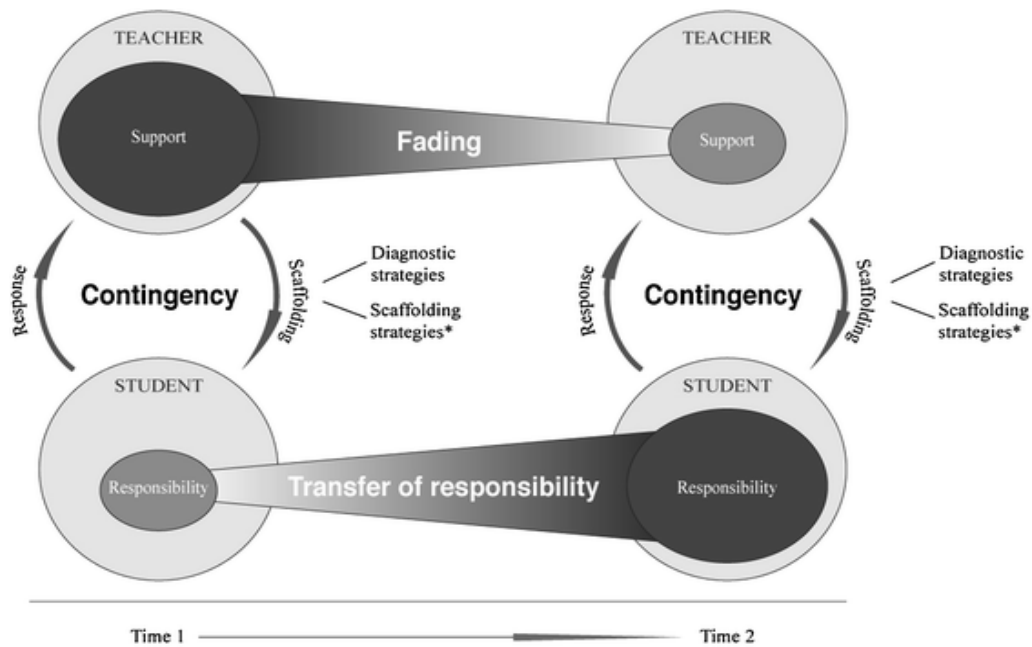

Figure 2.2. Van de Pol, Volman, and Beishuizen's (2010) conceptual model of essential elements of scaffolding.

Van de Pol and colleagues' (2010) conceptual model of scaffolding closely relates to the "Gradual Release of Responsibility Model" (Pearson & Gallagher, 1983; later adopted by Fisher & Frey, 2013), comprising three progressive phases: beginning with teacher responsibility; moving to joint responsibility; and finally ending with student responsibility (see Figure 2.3).

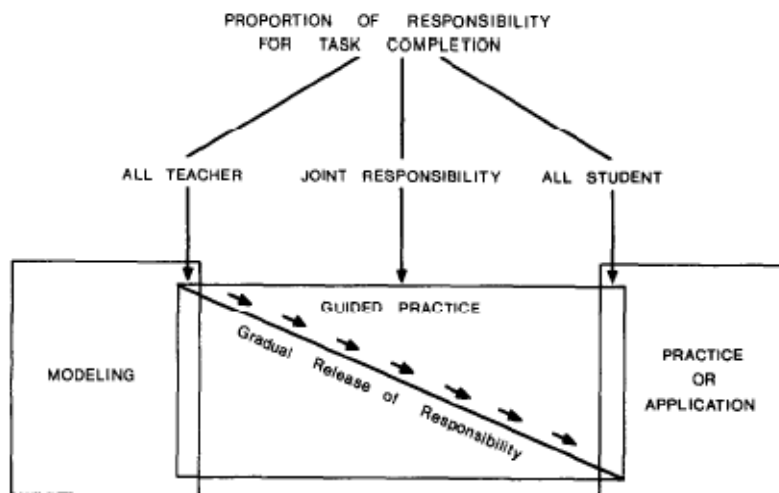

Figure 2.3. Gradual Release of Responsibility Model (Pearson & Gallagher, 1983).

The responsibility or ownership of the learning is slowly transferred from the teacher to the student. The Gradual Release of Responsibility Model was used in the construction of the teaching experiment lessons for this study (see section 3.5.2.1).

Research into scaffolding practices has been classified according to several different components. These include the following:

1. **Function:** This relates to the functions of the scaffolding. Many scaffolding models are based on work by D. Wood et al. (1976; e.g., six functions of scaffolding including *recruitment, reduction in degrees of freedom, direction maintenance, marking critical features, frustration control* and *demonstration*) and Tharpe and Gallimore (1988; e.g., assisted learning uses six functions of *modelling; contingency management; feeding back; instructing; questioning; and cognitive structuring*).
2. **Intention:** This relates to why the scaffolding is occurring. There are two reasons for scaffolding: (a) solving an immediate difficulty, such as gaining new knowledge, insight or skill to accomplish a task (i.e., any tool used to bridge a learner's ZPD); and (b) providing a basis for future independent learning by the individual (Holton & Clarke, 2006). The second intention, the future aspect of scaffolding, is fundamental to "what the child is able to do in collaboration today he will be able to do independently tomorrow" (Vygotsky, 1978, p. 21). Two scaffold types are used to achieve these intentions: (a) social scaffolds, which establish classroom norms; and (b) analytical scaffolds, which are supports for mathematical content (Nathan & Knuth, 2003; Speer & Wagner, 2009; William & Baxter, 1996). Finding an equilibrium between these two types of scaffolding is essential for students' success (William & Baxter, 1996). The intention of scaffolding highlights the significant role of social interaction.
3. **Means:** This involves classifying the scaffolding according to the role of agency (i.e., who is providing the effective scaffolding practices). It has been suggested that better student learning occurs by gradually transferring the role of agency from the teacher (expert scaffolding) to peers (reciprocal scaffolding) and eventually to the individual student (self-scaffolding), which is equivalent to metacognition (Holton & Clarke, 2006; Holton & Thomas, 2001). However, there is a paucity of research that illuminates how this transfer of agency occurs. This raises the question of who can act in an MKO role in effective scaffolding when using various manipulatives (e.g., PM or VM).
4. **Occurrence:** This relates to when the scaffolding is established. Brush and Saye (2002) suggest that there are two types: (a) "soft" scaffolding, where the teacher circulates around the classroom and converses with students when needed (Simons & Klein, 2007), in which the application of the scaffolding is situated or regarded as

“contingent scaffolding” (Van Liers, 1996); and (b) “hard” scaffolding, which is pre-planned in advance of the classroom lesson, and is based upon typical student difficulties in classrooms. Both occurrences of scaffolding require directions from an MKO.

5. **Modality:** This is the mode in which the scaffolding is presented (Pea, 2004). With advancements in technology, original scaffolding by an “adult” (MKO) has evolved to include technological scaffolding where computers are able to replace the teacher as experts or guides (Yelland & Masters, 2007). In the past decade, research into the benefits of technological scaffolding has surged. However, Pea (2004) warned that technological scaffolds by themselves are not responsive or contingent, as the teacher needs to decide what tools to use and when they can be withdrawn. This is an important consideration because contingency is cited as a crucial element to scaffolding and essential within a sociocultural framework (see Figure 2.2). This study proposes to expand on the understandings of technological scaffolding by comparing the influences that PM and VM have on the scaffolds implemented to support students’ spatial thinking, and the resultant student learning that occurs.

These components of scaffolding were carefully considered when deliberating a lens to use to examine the scaffolding practices within this study. First, the framework needed to align with sociocultural theory and acknowledge the importance of interactions between the teacher and students, with particular attention to the teacher’s action in scaffolding (i.e., what the MKO does to assist and support student learning). Second, the framework needed to comply with the three crucial elements of scaffolding as outlined in the conceptual model of Van de Pol et al. (2010). This required (a) a freedom of choice in the application of the appropriate scaffolding strategy contingent to students’ needs; (b) a progressive nature that allowed for student ownership and responsibility to transfer from the teacher; and (c) the ability to fade the amount of support given by the teacher. Finally, the framework had to be adaptable to incorporate the use of different types of manipulatives (PM or VM).

### ***2.7.1.3 Choosing Anghileri’s hierarchy of scaffolding practices as a lens to examine scaffolding (amalgamated, linked, connected)***

Anghileri (2006) created a hierarchy of scaffolding practices by amalgamating many of the practical aspects of the function, means, occurrence and intentions of scaffolding. The hierarchy created by Anghileri suggests that teachers provide three different levels of support to assist students’ mathematical development. While Anghileri did not suggest an order with

regard to how these scaffolds are applied within the mathematics classroom, she did acknowledge that “the establishment of practices at different levels reflects not only the progressive (and often circular) supporting strategies that can be used, ..., but also the way effective interactions may be developed” (Anghileri, 2006, p. 38). This link to effective interactions ties in with a sociocultural perspective. Additionally, Anghileri’s theoretical framework aligns with this present study as it arose from her analysis of data pertaining to teaching spatial concepts using physical materials within the primary classroom.

Figure 2.4 illustrates the three levels of Anghileri’s hierarchy of scaffolding practices. Within each level of support, strategies in the centre of the figure are those Anghileri observed as seen most frequently in the classroom. The practices located on either side of these central strategies are claimed to be less likely to occur but are considered to reflect effective teaching.

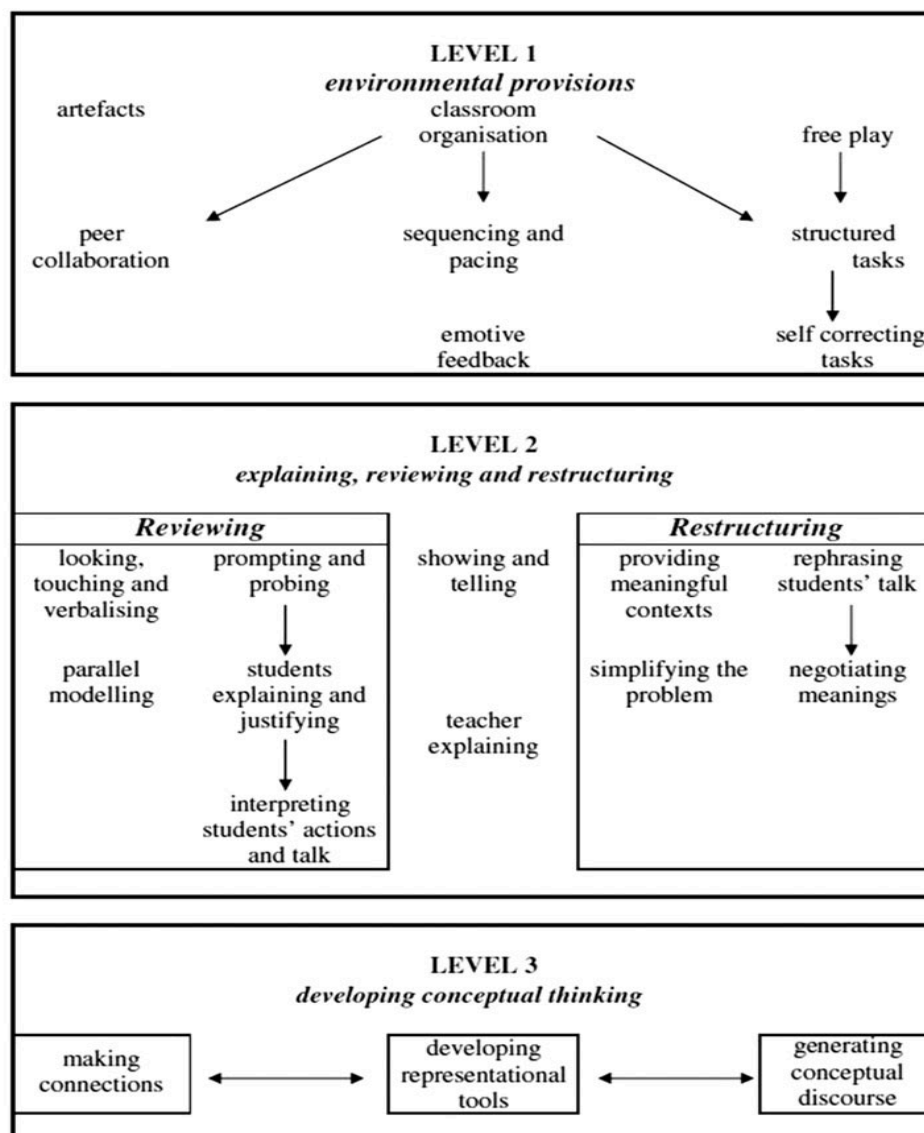

Figure 2.4. Anghileri’s hierarchy of scaffolding practices.

Level 1 scaffolding practices encapsulate the environmental factors associated with student learning. These practices include how the teacher organises the classroom, such as the design of the lesson and tasks, the incorporation of tools used to achieve desired outcomes, the method of instruction (e.g., peer collaboration) and the use of emotive feedback within the lesson.

Level 2 and Level 3 are more concerned with the mathematical learning that occurs as teachers interact with students. As this study is framed by sociocultural theory, these interactions (Level 2 and Level 3) form the main focus for this present study and thus are explained more thoroughly.

In Level 2, the teacher's scaffolding is centred on *explaining*, *reviewing* and *restructuring* mathematical concepts. When *explaining*, students' contributions are limited as the teacher uses direct instruction. Teacher scaffolding focuses on a "funnelling pattern of interactions" (T. Wood, 1994, p. 153), where students are guided to a predetermined solution through the teacher's use of leading questions. By contrast, *reviewing* scaffolds are purposely designed to focus on providing opportunities for student input. These opportunities are associated with T. Wood's (1994) "focusing pattern of interactions" that zooms in on the critical aspects of a problem or task that warrant students' attention and involve greater student responsibility for the resolution. These Level 2 scaffolds include the use of manipulatives to explore mathematical concepts, or various teacher-questioning techniques (e.g., prompting and probing, explanations or justifications). This level also includes the teacher paraphrasing students' speech or actions to clarify their responses, or parallel modelling where the teacher creates a similar mathematical problem but changes some of the characteristics. In these instances, the student retains ownership of the task and then must transfer the teacher's example back into the original problem. At this stage, the teacher can also introduce any *restructuring* practices required to promote student learning.

Restructuring practices include providing meaningful contexts for problems (i.e., relating the task to real life); simplifying the problem by breaking it down into more manageable parts; rephrasing terminology to build the formal, mathematical language required to accompany students' reasoning and explanations; and negotiation of the meaning of concepts. Anghileri (2006) highlighted the importance of negotiating meanings by stating, "it is through a struggle for shared meaning that a process of cooperatively figuring things out determines what can be said and understood by both teacher and students and this is what constitutes real mathematics learning in the classroom" (p. 46).

Level 3 scaffolding practices focus on how teachers provide support in the development of students' conceptual understandings of mathematics. Anghileri (2006) suggested that this occurs using three methods. The first method, *developing representational tools*, includes using language (sign systems) and objects (artefacts) to create links to visual imagery (mediation). The second method, *making connections* and challenging student ideas, goes beyond providing students with restructuring support and begins to help students generalise. This process pulls them forward in their ZPD. The third method, *generating mathematical discourse*, sees the teacher using questions to start mathematical conversations. These mathematical conversations provide students with opportunities to create shared understandings within the classroom, which allows students to reflect on and revise their own conceptual understanding.

Anghileri's hierarchy of scaffolding practices aligns with sociocultural theory, as most of the scaffolding practices are forms of communication (sign systems) fostering teacher and student interactions (Lange, Meaney, Riesbek, & Wernberg, 2014). The hierarchy also draws links to Vygotsky's work by acknowledging the use of tools (artefacts) in mediating students' mathematical learning. While Anghileri's hierarchy is a respected resource for analysing the role of the teacher in developing students' mathematical learning because the scaffolding practices focus on the teacher's actions, in this hierarchy there is minimal focus on, or attention given to, the role of students in this process. Therefore, while an insightful framework for examining the teaching dimension of the ZPD, a further lens is needed to analyse the communication between the teacher and students and the influence this has on students' learning in spatial thinking.

### **2.7.2 Using a commognitive approach as a lens to understand students' learning**

The second sociocultural lens used in this study focuses on understanding students' learning through communication. A communicational or a participative approach to learning, such as Sfard's commognitive approach, was developed to challenge the previously established acquisitionist approach. In an acquisitionist approach, the teaching of mathematics focuses on learning as an internal, cognitive function where mathematics is an external body of knowledge that is discovered or constructed by students. The construction of mathematical knowledge is depicted as modifications of internal mental representations to mirror those embodied in external instructional representations (Cobb, Yackel, & Wood, 1992). However, theories based on an acquisitionist approach fail to consider the social and cultural nature of mathematical activity. A commognitive approach (Sfard, 2001), inspired by the theories of Vygotsky, aims to answer the question of how human activity evolves and grows in complexity from one generation to another.

From this perspective, the particular human activity that mediates what people are doing is the act of communicating and learning mathematics.

The basic tenet of Sfard's commognitive approach is that "thinking is an individualization of interpersonal communication" (2007, p. 571). From this perspective, language and cognition are fused together. Interactions about mathematics are first experienced collectively (i.e., on a social plane) and then "individualised" to become individual cognition. Sfard's notion of *individualisation* is similar to Vygotsky's concept of internalisation. This is evident in Sfard and Kieran's (2001) study examining the conversations of students (aged 13) who were learning algebra concepts, which reported, "students' collaboration and mathematical conversation are the best way to learn mathematics" (p. 70).

Drawing from Vygotsky's work (1986) on thought and language, Sfard's definition of cognition is "to think means to communicate with oneself" (2008, p. 132). While Vygotsky (1986) stated that thought can exist without language, Sfard (2002b) suggested that thought exists because of language, which makes it an act of communication in its own right. Sfard argued that "our thinking is clearly a dialogical endeavor where we inform ourselves, argue, ask questions, and wait for our own response" (Sfard, 2002a, p. 322). This expands on Vygotsky's concept that increased language use leads to higher levels of thought, by assuming language is thought. Therefore, language is not just a medium used to express one's thoughts, but "thinking may be conceptualized as a case of communication" (Sfard, 2001, p. 26).

By assuming the lens of thinking as a communicational act (i.e., a commognitive approach), learning mathematics entails cognitive and sociocultural dimensions, and becomes an inseparable process that occurs within a community of practice (Wenger, 1998). Therefore, thinking mathematically and doing mathematics involves engagement in a communicational act known as mathematical discourse, and hence, learning involves becoming a participant in mathematical discourse (Sfard, 1998). Sfard's reification theory (1991) alluded to the discursive nature of student learning by stating that the development of concepts begins as a process (action) and moves towards a structural idea (object). Sfard (2002a) defined discourse as "any specific act of communication, whether verbal or not, whether with others or with oneself, whether synchronic (like a face-to-face conversation) or asynchronous (like in an exchange of letters or in reading a book)" (p. 322). An important consideration of Sfard's understanding of mathematical discourse is that our communication is not just verbal (i.e., language or speech), as discourses occur in multiple modalities (Sfard, 2014). This also implies that discourse can occur on both an individual and a societal level. With this mindset, thinking is "both dependent on, and informed by, the process of making communication effective with others or with



oneself” (Ryve, 2006, p. 34). Therefore, the unit of analysis with regard to the learning that is occurring is the mathematical discourse that transpires within the classroom (i.e., the way interlocutors, both student and teacher speakers, communicate). Therefore, two conditions need to occur to ensure mathematical learning (Sfard, 2014):

- students need exposure to new discourse (i.e., where “*communicational conflict*” occurs); and
- all the participants in the learning–teaching process need to be of the same mind in regard to (a) whose discourse is to be shared; (b) who needs to act as the teacher and who as a learner; and (c) what is the expected form, mechanism and pace of the learning.

The second condition, Sfard termed as the “*teacher–learner agreement*”. Both conditions for mathematics learning are explored further in the section of literature pertaining to the “routines” characteristic of mathematical discourse (see section 2.7.2.4).

To assist with Sfard’s understanding of learning as part of the communicational act of mathematical discourse, a number of interrelated characteristics are identified by Sfard to define mathematical discourse. These are used as a methodological tool to analyse the effectiveness of communicational acts and evaluate students’ learning. From Sfard’s perspective the four characteristics of discourse are as follows:

its special *keywords* [i.e., mathematical words], such as *three*, *triangle*, *set* or *function*, used in distinctly mathematical ways; its unique *visual mediators*, such as numerals, algebraic symbols, and graphs; its distinctive *routines*, that is, patterned ways in which mathematical tasks are being performed; and its generally *endorsed narratives*, such as theorems, definitions and computational rules. (Sfard, 2012, p. 2)

### **2.7.2.1 Mathematical words and learning**

Language (and word use) has often been cited as an important component in students’ mathematical learning (e.g., Pierce & Fontaine, 2009; Riordain & O’Donoghue, 2009; Schleppegrell, 2007; Warren & Miller, 2013). Previous research reports that young students’ use of, and understanding of, spatial words (Simms & Gentner, 2009), as well as their exposure to these words (Albro, Booth, Levine, & Massey, 2009) positively influences their spatial performance (Newcombe, 2010). Therefore, using mathematical words to analyse students’ learning is justifiable. Sfard (2001) introduced the term *special keywords* to denote words used in mathematical discourse that signify mathematical objects (numbers, shapes, etc.). These can include everyday words that students use in mathematics, as well as technical mathematical

vocabulary required for mathematical procedures, such as generalising. For the purposes of this study, special keywords include the mathematical vocabulary commonly used in mathematics classrooms. Within the context of spatial orientation and visualisation, special keywords include words such as *line*, *round*, *shape*, *edges*, *reflections*, *rotations*, *transformations*, and various positional language terms used to describe the orientation of objects.

Word use alone, however, does not provide a clear depiction of students' mathematical understanding. Halliday (1978) concluded that, from a language perspective, mathematics was not only about increasing one's vocabulary, but also entailed understanding new "styles of meaning and modes of argument ... and of combining existing elements into new combinations" (Halliday, 1978, pp. 195–196). Halliday referred to this as the *mathematical register*. Some grammatical patterns of the classroom mathematical register include: technical vocabulary; dense noun phrases; being and having verbs; conjunctions with technical meanings; and implicit logical relationships – using words such as *if* and *when* (Lemke, 2003; O'Halloran, 2003; Veel, 1999). Sfard (2008) argued that grammar, in the sense of syntax (i.e., the arrangement of words and phrases to create well-formed sentences in a language), is a central property of the linguistic element of communication. To examine this linguistic element of students' communication, students sentence structure needed to be organised into levels so that it could be analysed. Researchers agree that several stages of linguistic development exist (Kess, 1993; Steinberg, 1992; Stork & Widdowson, 1974). A general scheme for these linguistic stages include: (a) Prelinguistic (communication through gestures and crying; (b) Holophrastic Stage (use of one word utterances); (c) Telegraphic Stage (the use of words in combinations and simple phrases); and (d) Early Complex Sentences and Complex Sentences Stage (use of sentences and relative clauses) (Matthews, 1996). For the purposes of this study, these stages of linguistic development were modified to form the four levels of sentence structure used to analyse the grammatical complexity of sentences that students use in their mathematical discourse. The four levels of sentence structure are:

1. limited use of language (a combination of Prelinguistic and Holographic Stages);
2. simple sentences and short phrases (the Telegraphic Stage);
3. complex sentences (the Early Complex and Complex Sentences Stage); and
4. questioning.

As Cattell (2002) suggests, it isn't until two word utterances begin that grammatical constructions play a more vital role. For this reason, the first two stages were combined. Additionally, Holton and Clarke (2006) suggest that the use of questioning shows a progression

towards metacognition (i.e., students are thinking about their own thinking processes). Formulation of a question requires a student to think about what they already know and search for further information to extend it. Thus, questioning was considered to be at the highest level. Therefore, the two constructs used in this study to analyse students' mathematical words are (a) the grammatical complexity of sentences (e.g. limited use of language, simple sentences and short phrases, complex sentences and questioning), and (b) the use of special keywords (e.g., technical words).

### ***2.7.2.2 Visual mediators and learning***

Sfard (2008) used the term *visual mediators* for the symbolic presentations (i.e., visual representations) that form part of mathematical conversations and learning. In most cases, student learning can be visually and tangibly mediated with physical objects that students identify or point to as they use nouns and pronouns to describe the objects. Thus, from Sfard's perspective, visual mediators are the signs or tools used by teachers and students in mathematical discourse. Visual mediators can be dynamic (e.g., manipulative objects) or static (e.g., diagrams and graphs found in mathematics textbooks). and can evoke mathematical relationships and properties (Jackiw & Sinclair, 2009; Ng & Sinclair, 2015). Therefore, within this study, visual mediators (similar to Vygotsky's artefacts) include the external representations (i.e., PM or VM) used in the classroom for the development of students' spatial thinking. Sfard (2002b) claims that these manipulatives assist in the creation of mathematical discourse, and help to focus the discourse.

Additionally, gestures (signs in Vygotskian terms) are considered to be visual mediators as they are the complementary actions that form part of the communication process (Sfard, 2009). Therefore, "whoever posits that any act of communication is already an act of thinking must also agree that thinking can take any communicational form, including gesturing" (Sfard, 2009, p. 195).

Within the spatial domain, visual and temporal mathematical meaning is assisted by the use of gestures (Ng & Sinclair, 2015; Nunez, 2004; Sinclair & Tabaghi, 2010), and gestures act as a powerful instructional tool because they capture spatial relations between objects (Newcombe, 2010). This was evident in Ehrlich, Levine, and Goldin-Meadow's (2006) study in transformational geometry, which showed that gestures helped students focus their attention towards the transformational act rather than on the manipulatives used. Although Sfard acknowledges that gestures form part of the visual mediators' characteristics, she does not have a clearly defined classification system for different types of gestural acts. Thus, in this present

study, McNeill's (1992) categories provided the characteristics to explore changes in student gestures.

McNeill (1992) maintained that “gestures, together with language, help constitute thought” (p. 245) and that gestures and language occur simultaneously. McNeill (1992) classified gestures into four different categories to assist in analysing their influences on the learning process: pointing gestures (deictic gestures, such as pointing to existing or virtual objects); iconic gestures (a representation bearing a resemblance to the content of speech); metaphoric gestures (physical representation of an abstract idea); and beat gestures (simple repeated gestures used for emphasis).

For the purpose of this study, McNeill's categories, while extensive, are limiting because the teaching and learning of spatial thinking involves interactions with manipulatives (PM and VM). For this reason, it was necessary to extend McNeill's categories to include certain embodied actions defined as *grounding gestures* and *changes in body position*, to align with Sfard's definition of gestures as “spontaneous movements of the arms and hands ... closely synchronized with the flow of speech” (p. 11), and as “a body movement fulfilling communicational function” (Sfard, 2009, p. 194). Therefore, six gesture categories were used to analysis gestures in this study (see section 3.7.2).

The focus on gestures in this present study is also supported by findings of previous studies. Briefly, these are that gestures frequently accompany (Goldin-Meadow, 2003; Kendon, 1980; McNeill, 1992) and complement speech (Kendon, 2000); gestures can precede speech in mathematical development (Goldin-Meadow, 2003); gestures reduce the amount of speech needed by students because they produce their own meaning (Goldin-Meadow, Nusbaum, Kelly, & Wagner, 2001); and gestures enable students to express information not found in speaking (Alibali & Goldin-Meadow, 1993; Goldin-Meadow, Alibali, & Church, 1993; Perry, Church, & Goldin-Meadow, 1988). As a result, many researchers have linked frequency of gesture use with concepts related to spatial thinking (e.g., Emmorey, Tversky, & Taylor, 2000; Krauss, 1998; Lavergne & Kimura, 1987; Schaal, Uttall, Levine, & Goldin-Meadow, 2005). On the whole, gestures fittingly capture spatial information (Kita & Ozyurek, 2003; McNeill, 1992). Additionally, Rauscher, Krauss, and Chen (1996) found that when speakers were prevented from gesturing, their use of spatial words decreased, highlighting a link between the use of gestures and spatial language production. However, while there is a plethora of literature examining links between gesture use and spatial thinking, limited research on gestural interactions with different manipulative types has occurred, especially within an early years context.

From a sociocultural perspective, gestures are viewed as a powerful tool for improving learning (Newcombe, 2010). When a teacher uses gesture in instructions, students often learn better than when taught with speech alone (Singer & Goldin-Meadow, 2005). In addition, when third and fourth grade students (aged 8–10) gesture as they explain a problem either prior to (Broaders, Cook, Mitchell, & Goldin-Meadow, 2007 – study with 106 students), or during instruction (Cook, Mitchell, & Goldin-Meadow, 2008 – study with 84 students), they learn more than students who do not gesture. While the connection between gesture and spatial thinking is evident in previous research, the role of gestures in the growth of these skills is yet to be fully explored (Ehrlich, Levine, & Goldin-Meadow, 2006). In particular, how different manipulatives (i.e., PM and VM) influence both the teacher’s and the students’ use of gesture, within the teaching and learning of spatial thinking, warrants attention.

Not only are gestures cited as an important tool in conveying spatial information (Newcombe, 2010), researchers also acknowledge the benefits of particular gesture types, such as iconic and metaphoric gestures, in the process of objectification (e.g., Sinclair et al., 2016; McNeill, 1985, 1992). Iconic and metaphoric gestures are imaginistic gestures and serve several functions, such as depicting imagery (McNeill, 1992); serving as a bridge between internal imagery and formal, symbolic expressions of mathematical ideas (Arzarello, 2006); and providing opportunity to clarify space and shape aspects of abstract knowledge (Elia, Gagatsis, & van den Heuvel-Panhuizen, 2014). The use of iconic and metaphoric gestures allows students to “exhibit images of abstract concepts” (McNeill, 1985, p. 356). In other words, students use these gesture types to create an imagery of the concept (Edwards, 2009) and to make their realisations public to all participants of the mathematical discourse (Sfard, 2009).

While Sfard assigns gestures to the discursive characteristic of visual mediators, some researchers, such as McNeill (1992), claim that gestures are simultaneously created with abstract thinking, thereby functioning as either mathematical words or visual mediators of mathematical discourse. From this perspective, gestures have the power to communicate student learning independently from their use of words (Goldin-Meadow, 2003; McNeill, 1992; Moschkovich, 2007). Moschkovich (2007) showed that “even a student who is missing vocabulary may be proficient in describing patterns, using mathematical constructions, or presenting mathematically sound arguments” (p. 20). However, Sfard’s view of gesture, similar to Schleppegrell’s (2007), is that language (i.e., mathematical words) provides information about the context of the situation, while external mathematical representations (i.e., visual mediators and gestures) act as artefacts connecting the material world to mathematics. In other words, each form of communication acts as a “backup” to the other (Sfard, 2009). The role of

gestures in the communicational process, whether acting as mathematical words or as visual mediators, warrants further investigation. However, for the purposes of this study, gestures are incorporated within the visual mediators characteristic of discourse, as Sfard (2008) views them as part of what constitutes the physical manifestation (e.g., mathematical objects) of which abstractions are produced.

Additionally, it could be argued that gestures form part of the routines characteristic of discourse. However, as this study was based within a whole class context, analysis of gestures as a form of routines would be difficult to examine unless individual students were studied. As the focus of this study was on the interaction between teacher and students, assignment of gestures to the routines characteristic was beyond the scope of this thesis. These variations into the possible assignment of gestures into Sfard's characteristics of discourse highlight the complex nature of gestures. While there is no direct one-to-one correspondence of gestures to a particular characteristic, for analysis purposes, gestures were allocated solely to the visual mediator characteristic.

Furthermore, while Sfard includes many other kinds of visual signs in visual mediators (e.g. arrows, shapes, etc.), these have not been included in the analysis of students learning. Written visual signs, such as arrows and drawn shapes were not specifically used in the teaching of the PM class as the focus was on the influence of the physical manipulatives used in the lesson and the interactions between teacher and students. Additionally, written communication, either by the teacher, student or within the apps, was beyond the scope of this thesis as the focus of the study was on the interactions between teacher and students, in particular how they communicated with each other in the teaching and learning process. Therefore, the visual mediators that populated the apps also did not form part of this communication between teacher and students and thus an analysis on these types of visual mediators did not occur. While beyond the scope of this particular study, further studies in this area are warranted.

### ***2.7.2.3 Endorsed narratives***

Endorsed narratives are the stories students share that are either accepted or rejected by the mathematics community. Sfard (2007) elaborated by stating:

*Narrative* is any text, spoken or written, that is framed as a description of objects, or of relations between objects or activities with or by objects, and that is subject to *endorsement* or rejection, that is, to being labeled as *true* or *false*. (p. 574)

Within the context of mathematics, the mathematical theories used, such as mathematical definitions, proofs and theorems, are termed as *endorsed narratives* (Sfard, 2007). The

conditions of endorsement vary between discourses, and often the power relationship between interlocutors plays a significant role in which discourse is accepted and endorsed (Sfard, 2007). Endorsed narratives are viewed as the “factual knowledge” (Sfard, 2006, p. 163) obtained in mathematical discourse.

#### ***2.7.2.4 Routines and learning***

Routines are defined as “sets of constraining but flexible rules that govern patterns in discourse” (Felton & Nathan, 2009, p. 575). Within the context of classroom mathematics, routines are the procedures and practices that students engage in, and include social interactions such as generalising, looking for similarities and differences, and using methods of proving.

#### ***Defining routines***

There are three types of *routines* involved in “doing mathematics”: explorations, deeds, and rituals (Sfard, 2008). *Explorations* refer to the creation and maintenance of endorsed narratives. These types of routines are about getting to “know a piece of mathematics”, and are evidenced by created narratives rather than tangible changes in the environment. *Deeds* relate to effecting change on objects. Within this study, deeds relate to the manipulation of physical and virtual objects. *Rituals* are socially orientated routines, which usually begin by imitating the teacher. Sfard uses the term “thoughtful imitation”, an adaption of Vygotsky’s “reflective imitation”, to discuss the process involved in students’ thinking about the ritual of the imitated routines (which is the first step towards individualisation). Rituals are highly situated and are associated with teacher prompts. While Sfard (2008) views deeds and rituals as “developmental predecessors of explorations” (p. 223), all could be viewed as necessary steps in routine development in mathematics learning. As Sfard (2008) explains, students’ “first attempts at individualization of other people’s discourse ... are more likely to result in rituals rather than in explorations” (p. 246). In Vygotskian terms, ritual is the form routines take in the ZPD (Sfard, 2008; Vygotsky, 1978).

Changes in routine result in changes to the *teacher–learner agreement*. According to Sfard (2008), the teacher–learner agreement is effected by three basic aspects: (a) agreement on the leading discourse (i.e., who is leading the discourse); (b) agreement on the discursants’ roles (i.e., who is accepting these roles); and (c) agreement on the course of discursive change, being of “one mind as to the final goals of the process of learning and as to the manner in which learning is likely to occur” (p. 285). Changes in the teacher–learner agreement lead to *commognitive conflict*, which acts as the “gate to the new discourse” (Sfard, 2008, p. 282).

Commognitive conflict occurs whenever interlocutors differ in their word use, how they view and interpret visual mediators, or in the discursive procedures they use to solve a problem or in a particular situation (Cobb, 2006; Sfard, 2015). Previous studies have identified this conflict as “mismatch”. The concept of “gesture–speech mismatch” was introduced by Goldin-Meadow (2003) to denote where different messages are represented in students’ utterances and gestures. Sfard (2008) argued that a discursive change occurs when there is a communicational conflict (i.e., a discrepancy) between interlocutors. This conflict is the result of different participants acting according to differing discursive rules. To overcome this conflict, the participants need to scrutinise the teacher–learner agreement and decide (a) whose discourse is shared; (b) who acts as teacher and who as learner; and (c) what are the expected form, mechanism and pace of the learning process (Sfard, 2015).

However, other researchers have proposed that this mismatch of information should not be viewed as conflicting but possibly as complementary (Alibali, Kita, & Young, 2000; Goldin-Meadow, 2003). They believe that commognitive conflict (i.e., mismatch) may signal that students are ready for the next level of learning. This idea stems from research findings demonstrating that learners can express understanding of new concepts through gestures before speech (Goldin-Meadow, 2000). The identification of mismatch also highlights the importance of examining all communicational acts in student learning. As Goldin-Meadow (2000) suggested, if gesture pinpoints areas where students are ready to learn, then it functions as an externalised index of the student’s “proximal zone” (Vygotsky, 1978). Commognitive conflict can also result in changes in the teacher–learner agreement.

### ***The role of the teacher in a commognitive approach***

While the commognitive approach primarily focuses on student learning, Sfard (2001) argued that students can only develop routines to ensure mathematical learning through interactions with an expert participant (i.e., MKO). Students’ learning of mathematics occurs through mathematical discourse. Mathematical discourses are developed from discourses that students are already fluent in. The teacher’s job is to modify and exchange these existing discourses. Therefore, learning mathematics is a “process of changing one’s discursive ways in a certain well-defined manner” (Sfard, 2001, p. 25). More than other disciplines, the construction of mathematical knowledge depends on the elucidations given by the teacher, which are language based (Schleppegrell, 2007). It is through the teacher’s use of oral language that the meanings of mathematical symbolism are unpacked and explained (O’Halloran, 2000), and through overtly directing students’ attention to linguistic features that technical mathematical meanings are clarified (Sfard, Nesher, Streefland, Cobb, & Mason, 1998).



However, “to become aware of this discourse’s advantages one has to use it; yet, to have an incentive to use it, one has to be aware of the prospective gains of this use” (Sfard & Lavie, 2005, p. 288).

Teachers’ guidance supports students’ understanding of spatial concepts (Sinclair & Moss, 2012). In a study that entailed using a Sfardian approach (i.e., thinking becomes a form of communication) to modify Van Hiele levels of geometric thought, Sinclair and Moss (2012) found “the view of geometric thinking as a form of communication entails that this thinking arises as a result of interactions with expert participants of the activity” (p. 30). Thus, the teacher’s role in progressing students through levels with the assistance of phases of learning cannot be ignored. Sinclair and Moss (2012) also highlighted how teacher scaffolding using virtual manipulatives allowed for greater negotiated meaning to occur. A significant finding of the study was that the number of three-sided polygons that students categorised as a triangle increased when DGE was accompanied by teachers questioning students. This improvement did “not happen without engaging the children in explicit meta-talk – in the reflection in these routines and their possible alternatives” (Sinclair & Moss, 2012, p. 42).

While the role of teachers is highlighted as important within Sfard’s commognitive approach, analysis of the changes in the teacher’s discursive characteristics is rarely discussed in the literature. Previous research (e.g., Shulman, 1986) has acknowledged the need for teachers to have deep pedagogical knowledge and content knowledge to extend students’ mathematics learning. While Sfard acknowledges the importance of teachers in the learning process, their role within her approach needs to be expanded upon. The aim of this study is to explore the use of representations (i.e., PM and VM) in the teaching and learning process and their influence on Year 3 students (aged 8–9 years).

Through the development of a commognitive approach, which provides both the theoretical and the analytical tools to investigate mathematical discourse, Sfard (2002a) challenged the dichotomy that exists between the cognitivist (individual perspective) and interactionist (social perspective) approaches. She suggested that the two approaches were just different ways of looking at the phenomenon of communication. Based on Vygotsky’s work (1978, 1987), Sfard (2000) suggested that “investigating communication with others may be the best route to discovering the mechanisms of human thinking” (p. 296), as a commognitive approach “provides a unified set of conceptual tools with which to investigate cognitive, affective and social aspects of mathematics learning” (Sfard, 2012, p. 1). As Radford, Schubring, and Seeger (2011) noted,

in highly social and cultural organized institutional settings, such as the school, learning cannot be abstracted from teaching... teaching and learning appear as two sides of the same coin: they are considered as part of a same process, connected by interrelated processes of signifying and meaning-making. (p. 149)

Thus, by using Sfard's commognitive lens to analyse both teachers' and students' communication, greater insights into the changes in the teacher-learner agreement and thus the teaching and learning of spatial thinking can occur.

## 2.8 RESEARCH QUESTIONS REVISITED

By applying a sociocultural perspective to this study, gaps in the literature related to the teacher's role are raised. The first part of the literature review examined the influences of representations on students' learning, and raised the question:

- *What influence do different external representations (e.g., PM and VM) have on young students' learning of spatial thinking?*

However, the critique of the literature, highlighting the interactive nature of student learning, raised the need to pay particular attention to the teacher's role within mathematics classrooms. This formulated a second question:

- *What changes occur in the teaching and learning of spatial thinking when using different external representations (e.g., PM and VM)?*

While Van Hiele's development of geometric thought acknowledges the importance of teaching through his phases of learning, his model has been criticised for not illuminating how different representations can influence the teaching of spatial thinking, nor does it give insights into the relationship between the teacher's role and the different representations used. Additionally, although vocabulary is highlighted in Van Hiele's model, extension of the influences of both the teacher's and students' use of language as a representational system is required, particularly with regard to how the communication used may relate to the representations used. This is of the utmost importance as young students' difficulties with representations (see section 2.3.1) and language (see section 2.3.2) are cited as areas of concern in developing students' spatial thinking. By adopting Anghileri's hierarchy of scaffolding practices and Sfard's commognitive approach to examine students' learning and the relationship between teaching and learning, a more thorough examination of the whole process of teaching and learning spatial thinking can occur.

## 2.9 CHAPTER REVIEW

The first part of the chapter investigated why and how spatial thinking is developed in young students. Criticisms of Van Hiele's model for development of geometric thought were raised and the area of external representations (including language) was noted as an area of concern that required further investigation.

The next section examined the representational literature. While previous research into the development of young students' spatial thinking with either PM or VM has mainly reported positive results (e.g., Highfield & Mulligan, 2007; Riconscente, 2013; Warren & Miller, 2013), few comparative studies exist and those few have produced varied results (e.g., Brown, 2007; Clements, 1999; Lowrie, 2002a; Olkum, 2003; Suh, 2005). A number of gaps in the literature were identified. These gaps include a lack of focus on (a) early years contexts (most studies have occurred within a secondary context); (b) the cognitive benefits of different external mathematical representations (i.e., manipulatives) with regard to spatial thinking (e.g., VM literature has focused on benefits pertaining to student engagement); and (c) the teacher's role in development of spatial thinking (e.g., most studies focus on students' learning). These gaps identify a need for a comparative study that not only focuses on students' learning, but also investigates the influences of teaching on learning and learning on teaching. In other words, there is a need for a study that examines the sociocultural aspects of both teaching and learning and young students' spatial thinking.

The theoretical framework used to frame this present study was introduced in the next section. Vygotsky's sociocultural theory, with fundamental concepts of internalisation, mediation (including the use of cultural tools), the ZPD, and the interrelationship between thought and language, were recognised as vital to the theoretical perspective of the study. Most importantly, the idea that mediation involves the use of tools (i.e., objects and artefacts, such as representations) and symbol systems (i.e., signs, such as language) was understood as the backbone to this present study. As a sociocultural perspective aims at examining the social and cultural routines and interactions between the participants (i.e., the teacher and students), more specific sociocultural lenses were required to analytically examine the role of each separately.

To examine the teaching aspect of young students' learning in spatial thinking, Anghileri's (2006) hierarchy of scaffolding practices was identified as an appropriate lens for this present study. This hierarchy offers a practical guide for teachers on how to scaffold students' learning, which progresses through three levels. Anghileri's hierarchy fits the criteria of being an appropriate scaffolding lens as it (a) aligns with sociocultural theory; (b) contains the three crucial elements of scaffolding, that is, contingency, fading, and transfer of

responsibility (Van de Pol et al., 2010); (c) provides both social and analytical scaffolding (William & Baxter, 1996); and (d) was adaptable to different “modalities” (Pea, 2004) of scaffolding (i.e., PM and VM).

Sfard’s (2001) commognitive approach was identified as an appropriate lens to analyse students’ learning because observed changes in students’ communication evidences students’ changes in mathematical learning. The application of this lens was appropriate for this present study as it (a) aligns with sociocultural perspective; (b) focuses on various characteristics of communication (i.e., mathematical words, visual mediators, endorsed narratives, and routines); and (c) provides an analytical tool for examining not only students’ communication but also the teacher’s.

The next chapter outlines the research design delineated to address the research questions and articulates how the sociocultural lens of Anghileri’s (2006) hierarchy of scaffolding practices and Sfard’s (2001) commognitive approach were used for the analysis the data.

## Chapter 3: Research Design

---

### 3.1 CHAPTER OVERVIEW

The purpose of this chapter is to present and justify the research design that underpinned the study which examined the influence different external representations have on the teaching and learning of spatial thinking with young students. The research problem identified in Chapter 2 affirms that spatial thinking is an area of concern for students from disadvantaged contexts. Thus, the aim of the study was to explore the use of external mathematical representations (i.e., PM and VM) in the teaching and learning process and their influence on Year 3 students (aged 8–9 years). As students constructed their spatial thinking while using manipulative materials within a sociocultural environment, an interpretive paradigm was an appropriate epistemological, ontological and methodological stance for the study. The following research questions informed the data collection methods used in this investigation:

1. *What influence do different external representations (e.g., physical manipulatives and virtual manipulatives) have on young students' learning of spatial thinking?*
2. *What changes occur in the teaching and learning of spatial thinking when using different external representations (e.g., physical manipulatives and virtual manipulatives)?*

This chapter provides a description and justification of (a) the choice of research design and methodology; (b) the participants; (c) the data collection methods, including the spatial testing instruments and the teaching experiments; and (d) the methods of data analysis. Consideration is given to the trustworthiness, ethical considerations and limitations of the study. Figure 3.1 presents an overview of Chapter 3.



*Figure 3.1.* Overview of Chapter 3.

## **3.2 RESEARCH DESIGN**

The following section attends to the adopted epistemological assumptions that determined the theoretical perspective and methodology chosen for the study. This research design aspires to fill a gap in current research about how different external representations, in particular PM and VM, influence the teaching and learning of spatial thinking of young students from disadvantaged contexts. The examination of the data collected required an interpretation of the mathematical meaning constructed through the teaching and learning interactions that occurred in the classroom. Thus, the overarching stance adopted for the study was an interpretative paradigm with sociocultural theoretical perspectives. As the research was undertaken in a classroom, where knowledge is bound by social constructs, a sociocultural perspective was utilised to provide insights into changes that occurred in the teaching and learning when different representations were used (see section 2.6 and section 2.7). These sociocultural perspectives influenced how the lessons were designed and how the new findings were interpreted. Table 3.1 displays the elements of theoretical framework that underpinned this study.

Table 3.1

*Theoretical Framework of the Study*

PARADIGM	Interpretative
THEORETICAL PERSPECTIVES	Sociocultural perspective – utilising Anghileri’s hierarchy of scaffolding practices (2006) and Sfard’s commognitive approach (2001)
METHODOLOGY	Case study of classes via a teaching experiment with a quasi-experimental design

**3.2.1 Interpretative paradigm**

The study used an interpretative paradigm to understand how students construct their world (Candy, 1989). An interpretative paradigm “assumes a relativist ontology (there are multiple realities), a subjectivist epistemology (knower and respondent cocreate understandings), and a naturalistic (in the natural world) set of methodological procedures” (Denzin & Lincoln, 2005, p. 25). This interpretative perspective allows the researcher to explore the way the world is built through social interactions that are influenced by culture, social context, historical perspectives and language (Gibbons & Sanderson, 2002). An interpretative perspective is an analytical system, generous in the allowance for abstraction and relative truth, which through observations of social interactions of individuals within their natural context arrives at perceptions of how individuals generate understandings from their social environment (Nueman, 1997). Knowledge is sustained through social processes, and intertwined with social actions (Young & Collin, 2004). Therefore, “the social world can only be understood from the point of view of the individuals who are part of the ongoing action being investigated” (Cohen, Manion, & Morrison, 2007, p. 19). This viewpoint is crucial to this study, as the researcher observed students in their natural learning environment acting as an inquirer, yielder of knowledge, and observer of knowledge construction (Candy, 1989). Denzin and Lincoln (2005) postulated that the researcher acts as philosopher and interpreter, as the researcher is attempting to divulge the relative truth and knowledge from the context they are within.

Interpretivism provided space for both qualitative and quantitative research methods to explore how different external representations influenced the teaching and learning of disadvantaged students’ spatial concepts, as the primary focus of this study was to gain the meaning that the participants attributed to their experiences. Framed in sociocultural theory, qualitative data were extracted in the form of words, gestures, and actions that in turn were used to examine the diverse perspectives and social practices that the participants used to generate knowledge. Interactions and personal experiences influence how one learns (Vygotsky, 1978,

1986), making the use of a qualitative approach very practical and “hands on”, when answering “how” and “what” questions. Quantitative data were used to gauge the changes that occurred in students’ spatial thinking over the course of the study, and in particular to explore the integrity of each type of representations as a supporter of spatial thinking development.

There are several strengths and weakness associated with a qualitative design. A main concern is that more time is consumed when conducting insightful research (Atkinson & Delamont, 2006). Researchers are often overwhelmed with the rich descriptions of the phenomenon studied and experience difficulties when reporting findings. In addition, terms or phrases used by a participant in the study may be interpreted differently by different people, including the researcher (Gall, Gall, & Borg, 2003). For this reason, peer review and debriefing occurred at the conclusion of each day throughout the data collection phase to eliminate researcher bias and misinterpretations.

An interpretative paradigm, as an epistemological approach, suggests making “meaning” or “knowledge” is a product of social interaction (Stahl, 2003). It is not waiting for “truths” to be found but rather constructing and reconstructing knowledge through negotiations and relationships between community members (Lincoln & Guba, 1985; Schwandt, 1994, 2000). This approach lends itself to the exploration of students’ spatial thinking as students construct their knowledge from the interactions they experience with external representations. Understanding is achieved from the truth and meaning that exists in the external world (Piaget & Inhelder, 1967; Gray, 2004). During this process, students use language, gestures and other social interactions to assist in the creation of their understanding. In this instance, these social interactions occurred in classroom settings. “All knowledge and hence all meaningful reality is contingent upon human practices being constructed in and out of the interactions between human beings and their world, and developed and transmitted within an essentially social context” (Crotty, 1998, p. 42). The meaning and understanding developed from this present study comes from the students themselves. An interpretative paradigm lends itself to the exploration of mathematical representations as students construct knowledge from the known context of the external representation and apply it to their thinking.

### **3.2.2 Sociocultural theoretical perspective**

The theoretical lens applied to this study was a sociocultural theoretical framework, as introduced by Vygotsky (1978). As discussed in Chapter 2, the literature review, practical application of this theory permitted a narrowing lens to pinpoint particular aspects of the teaching of spatial thinking and students’ learning of spatial thinking. Within this study, these



practical applications included the use of Anghileri's hierarchy of scaffolding practices (2006) and Sfard's commognitive approach (2001). Sfard's commognitive approach was also used as a methodological tool to analyse the data, rather than solely as a theoretical framing.

### **3.3 RESEARCH METHODOLOGY**

#### **3.3.1 Case study methodology with quasi-experimental design**

##### ***3.3.1.1 Case study methodology***

Case study was the most appropriate methodology to use in this study as it enabled the researcher to practically explore the influence of external representations on students' spatial thinking within a bounded setting, the classroom. It also ensured that students participating in the study were from a similar context and classroom environment and had similar prior experiences and backgrounds. For this study, the case is one year level of students (Year 3 students) from two schools (School A and School B) with similar disadvantaged contexts (i.e., low ICSEA scores and a large percentage of LBOTE students).

The case study was relevant to exploring this research problem as it allowed for rich descriptions that captured the narrative of the subjects under consideration. By conducting a case study, extensive clarification and examination of the phenomena could occur to gain deeper understanding of the experiences of participants (Creswell, 2008; Merriam, 1998). As a case study seeks to discover new knowledge, or confirm existing knowledge, it occurs in a naturally social setting like classrooms with close interaction with practitioners. In addition, case studies are (a) particularistic, as they exclusively commit to one group with the central focus of revealing the phenomenon or events of the subjects under consideration; (b) descriptive, with rich data based on observations gathered within a social context that relate to the children's own experiences; and (c) heuristic, as they allow for the discovery of new meaning or extension to current understandings, or confirm existing understanding (Merriam, 1998, 2001). Case studies explore or describe a phenomenon, in context, using a variety of data sources (Yin, 2003). While the majority of data collected is qualitative as it seeks to study phenomena in context rather than independent of the social setting, the inclusion of quantitative data can occur (Yin, 2003).

A limitation of a case study methodology is associated with generalisability from single cases and bias towards verification (Flyvbjerg, 2006; Yin, 1994). Another criticism is the bias or subjectivity of the researcher, where their preconceived notions could be evident in the findings observed (Flyvbjerg, 2004, 2006). While this is a concern with any qualitative design,

the researcher attempted to address these validity and trustworthiness issues by using triangulation and peer review. The researcher also acknowledged that there could be multiple interpretations for a particular instance (Stake, 2005) and therefore debriefed with peers at the conclusion of each day to assist in alleviating this concern.

### ***3.3.1.2 Quasi-experimental design***

Teaching experiments were applied using a quasi-experimental design (see section 3.5.2). Quasi-experimental designs allow observation of the impact of an intervention on its targeted population without the use of random assignment (Shadish, Cook, & Campbell, 2002). This method raises concerns for validity, as treatment and non-treatment groups may not be comparable at the beginning of the study. However, these concerns were attended to within this study by, firstly, choosing two schools within the same ICSEA range and, secondly, analysing pre-test data from the quantitative instruments. For the purposes of this study, the quasi-experimental design involved three groups (i.e., classes). Two classes from School A participated in teaching experiments over a two-week period (the treatment classes) and one class from School B did not participate in the teaching experiments (the control class). As this study occurred within a school setting, using multiple classes, a randomisation of participants was considered to be impractical and unethical. Additionally, a quasi-experimental design minimised threats to ecological validity as these natural environments were maintained (Brewer, 2000).

## **3.4 PARTICIPANTS**

### **3.4.1 Students**

Selection of the schools to participate in the study was based on two criteria: (a) ICSEA scores from NAPLAN (i.e., an ICSEA score <1000 indicated a disadvantaged context); and (b) a student cohort with a large percentage of students ascertained as LBOTE. The chosen schools had scores lower than the Australian average score of 1000: School A had a score of 961 and School B had a score of 946, indicating that both schools were of a similar level of educational disadvantage. Both schools also had high percentages of students with LBOTE: School A had 77% LBOTE and School B had 78% LBOTE. Year 3 classes, with students aged approximately 8–9 years old, were selected, as students at this age are able to sufficiently articulate their understandings and justify their thinking. Year 3 is also the first year of schooling that participates in the NAPLAN testing regime. The two classroom groups from School A were randomly appointed to participate as either one of two experimental groups: using PM ( $n = 23$ ) or using

VM ( $n = 27$ ). All students ( $n = 68$ ) participated in the spatial testing, and 50 students (i.e., the students from the two classes from School A) were involved in the teaching experiment lessons.

### 3.4.2 Researcher

The researcher played a pivotal role in the teaching experiment. As the research design comprised three purposely chosen classrooms with similar educational disadvantage and spatial ability (established by the results of the pre-test, see Chapter 4), to standardise and control the teacher's role in the data collection (Isaac & Michael, 1971), the researcher carried out the role of teacher in both the PM class and the VM class. Additionally, this ensured that the knowledge (subject matter knowledge and pedagogical knowledge) of the teacher, a construct that has been clearly shown to affect student learning in mathematics classrooms (Campbell et al., 2014; Hill, Rowan, & Ball, 2005; Shulman, 1986), was the same for each class. Similar studies in the past have adopted this approach (e.g., Carraher, Schliemann, Brizuela, & Earnest, 2006; J. Miller, 2014) in order to maintain trustworthiness of their studies.

## 3.5 DATA COLLECTION STRATEGIES

The data collection strategies comprised two instruments to collect data in order to answer the research questions. These instruments were (a) spatial testing materials, and (b) teaching experiments. Presented in Table 3.2 are the stages of data collection and the purpose of these data in answering the research questions.

Table 3.2

*Timeline and Stages of Data Collection*

Stage, purpose and instrument	Data collection	Data analysis	Purpose
<b>Stage 1:</b> September 2014; duration: 1 week			
Baseline data			
Classroom observations (3 classes)	Anecdotal notes in the form of a field journal	<ul style="list-style-type: none"> <li>Peer debriefing of field journal</li> </ul>	<ul style="list-style-type: none"> <li>Determine how students interact within each classroom setting</li> <li>Observe interactions between teacher and resources</li> </ul>
<b>Stage 2:</b> October 2014; duration: 20 minutes each test			
Baseline data			
Pre-testing of spatial testing material (SO, SV1, SV2, SCK –	Administered to all participants ( $n = 68$ )	<ul style="list-style-type: none"> <li>SPSS analysis of descriptive data and means</li> </ul>	<ul style="list-style-type: none"> <li>Determine students' current level of spatial thinking</li> </ul>

Stage, purpose and instrument	Data collection	Data analysis	Purpose
including NO, NV1, NV2)		<ul style="list-style-type: none"> <li>Comparative analysis of the three classes (ANOVA and paired t-tests)</li> </ul>	<ul style="list-style-type: none"> <li>Identify any significant differences between classes</li> </ul>
<b>Stage 3:</b> October 2014; <b>duration:</b> 2 weeks			
Research Question 1 Research Question 2			
Teaching experiments Two treatment groups (PM class and VM class)	Video and audio recording of teaching experiment lessons (PM and VM classes: $n = 50$ ) Field journal notes	<ul style="list-style-type: none"> <li>Peer debriefing of video recordings, viewed and transcribed at the conclusion of each day to discover relevant themes, conjectures and hypotheses</li> <li>Coding using Anghileri's hierarchy of scaffolding practices and McNeill's gesture categories</li> <li>Analysis according to Sfard's commognitive analysis approach</li> <li>SPSS analysis of coded items using Pearson's chi-squared test</li> </ul>	<ul style="list-style-type: none"> <li>Analyse responses and interactions for trends and patterns</li> </ul>
<b>Stage 4:</b> October 2014; duration: 20 minutes each test			
Research Question 1			
Post-testing of spatial testing material (SO, SV1, SV2, SCK – including NO, NV1, NV2)	Administered to all participants ( $n = 68$ )	<ul style="list-style-type: none"> <li>SPSS analysis of descriptive data and means</li> <li>Comparative analysis of the three classes (ANOVA and paired t-tests) to reveal significant differences</li> </ul>	<ul style="list-style-type: none"> <li>Determine level of growth in students' spatial thinking</li> <li>Identify any significant differences between pre- and post-testing</li> <li>Identify any significant differences between classes</li> </ul>
<b>Stage 5:</b> April 2015; duration: 20 minutes each test			
Research Question 1			
Post-post-testing of spatial testing material (SO, SV1, SV2, SCK – including NO, NV1, NV2)	Administered to the two treatment groups (PM and VM classes: $n = 50$ )	<ul style="list-style-type: none"> <li>SPSS analysis of descriptive data and means</li> <li>Comparative analysis of the two classes (ANOVA and paired t-tests) to reveal significant differences</li> </ul>	<ul style="list-style-type: none"> <li>Determine growth of students' spatial thinking</li> <li>Identify any significant differences between pre-, post- and post-post-testing</li> <li>Identify any significant differences between classes</li> </ul>

### **3.5.1 Development of the spatial testing materials**

The spatial testing materials consisted of four paper-based tests. These were administered to gather quantifiable data to answer the first research question regarding the influence of external representations on students' spatial thinking. The tests comprised three factor-referenced cognitive tests as previously published by Ekstrom, French, Harmon, and Derman (1976) measuring students' spatial thinking (i.e., SO – Spatial Orientation Test; SV1 – Spatial Visualisation Test 1; and SV2 – Spatial Visualisation Test 2); and a Spatial Content Knowledge (SCK) test devised using previous NAPLAN practice questions. The SCK test was split into three sections to mirror the three different dimensions of spatial thinking found in Ekstrom et al.'s (1976) testing material (i.e., SO, SV1 and SV2), which are referred to in the data analysis as NO, NV1 and NV2. The four spatial testing materials are presented in Appendices A–D. An overview of how the testing materials are linked to the two spatial thinking components (i.e., SO and SV) is presented in Appendix E.

For the SCK test, face validity occurred by mathematics professionals examining, scrutinising, and making comments or recommendations with regard to the chosen items. Content validity was established through examination of (a) current mathematics curriculum materials; and (b) achievement levels for geometry-based questions on NAPLAN testing materials.

### **3.5.2 Teaching experiments**

To answer the second research question, teaching experiments were used to explore how the teaching and learning changed according to the use of different external representations. Teaching experiments were used to directly experience students' mathematical learning and reasoning in relation to their mathematical thinking (Steffe & Thompson, 2000). Four elements facilitate this exploration through a sequence of teaching episodes: the teaching agent; the students; witnesses; and a method of recording (Steffe & Thompson, 2000). For the purposes of this study, the teaching agent was the researcher, the students were the two classes from School A (i.e., the PM class and the VM class), the witnesses were the classroom teachers and principal supervisor, and all classroom lessons were videotaped for recording the data for further analysis.

Teaching experiment methodology in education has its origins in the Vygotskian notion that the teaching experiment performed navigates changes under the effect of instruction. The primary goal of teaching experiments is to emphasise the creation and development of theories of learning, with the improvement of the learning process in a particular classroom seen as the

secondary goal (Cobb, Confrey, diSessa, Lehrer, & Schauble, 2003). The role of the researcher in teaching experiments is to construct models of students' mathematics understanding. This is completed by observing students as they engage in mathematical activity, because what students say and do during this activity indicates their mathematics understanding (Steffe & Thompson, 2000). Through this process, understanding into students' mathematical reality is examined.

### ***3.5.2.1 Development of the teaching experiment lessons***

The development of the lessons for the teaching experiment were based on types of spatial thinking reflected in the two types of spatial abilities defined in section 2.2.1, namely, spatial orientation and spatial visualisation. Two weeks were dedicated to the teaching experiments. The two weeks were divided evenly into exploring the two overarching spatial abilities: spatial orientation and spatial visualisation. In all, six lessons of approximately one-hour duration for each class (PM and VM) were designed for this study. The first week (Lessons 1 to 3) focused on spatial orientation skills. These lessons explored students' spatial thinking related to (a) perceiving figures as a whole from different orientations, and (b) identifying objects when seen from different positions. The second week (Lessons 4 to 6) focused on students' spatial visualisation skills. These lessons explored students' spatial thinking related to (a) reconstructing and deconstructing 3D objects, and (b) transforming spatial configurations.

When developing a lesson plan structure for the teaching experiment lessons, a model was adapted from current teaching practices occurring within the schools participating in the study. Both schools use a Gradual Release of Responsibility Model (Fisher & Frey, 2013) as the basis for lesson plan organisation. The Process of Learning as outlined by Education Queensland (Queensland Department of Education and Training, 2016) states that the lesson develops through three phases: Orientate, Enhance and Synthesise. The Orientate phase refers to the process of activating prior knowledge of the concept, and providing students with an outline of the learning. Teaching strategies used in this phase may include immersion in the concept (that is, giving the students multiple examples) or introduction to a concept by providing an experience that engages the student with the concept. This includes the revision of work from the prior lesson through the use of demonstrations, modelling, brainstorming, or making links through questions. In the Enhance phase students are given opportunities to engage with the concept and skills to consolidate learning. Teaching strategies in this phase include teacher scaffolding and students working independently. This phase is all about guided practice. It involves the use of instructional activities, questions, focused inquiry, summarising, and discussion. During the Enhance phase, reinforcement-type tasks occur. Finally, the Synthesise phase is where it is conjectured that students integrate their new understandings and

skills with their previous understandings and skills. This phase sees students' knowledge being demonstrated, explored, built on, and transferred to new situations. As the concept of scaffolding is closely related to this learning process, which uses the Gradual Release of Responsibility Model, this framework was applied to the construction of lessons in the teaching experiment part of this study. However, within this study, lessons were divided into four phases. These were Orientate, Enhance: Explicit Modelling, Enhance: Guided Application, and Synthesise. The reason for the split of the Enhance phase was to closely align these phases with Van Hiele's (1986) Phases of Learning for the development of geometric thought. As discussed in Chapter 2 (see section 2.2.3.1) Van Hiele noted five phases of learning. Figure 3.2 illustrates how the proposed four phases used in this study align with Van Hiele's Phases of Learning.

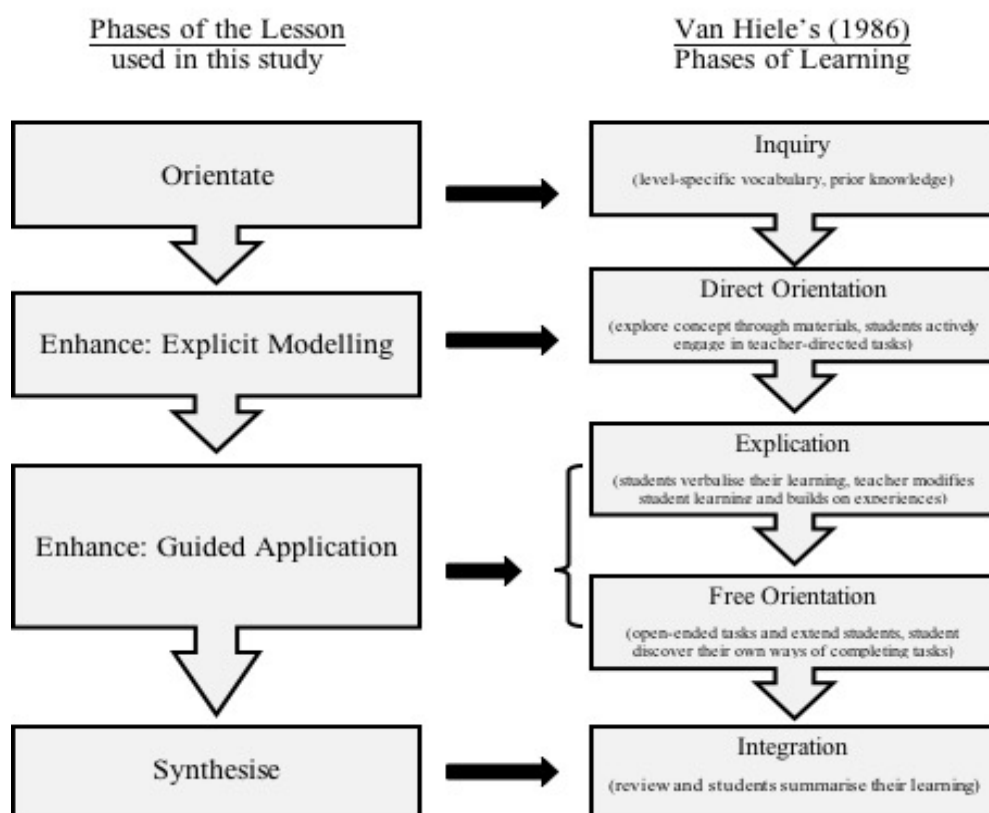

Figure 3.2. A comparison of lesson phases used in this study to Van Hiele's (1986) Phases of Learning.

To ensure both the PM and the VM classes' lessons were matched with similar tasks when exploring each concept, the PM class's lessons were designed around the virtual application chosen for the VM class's lessons. The selection of the apps used in this study was chosen from the Apple App Store. This choice was influenced by the Apple iOS platform being the most popular tablet platform (Mainelli, 2013) and the Apple App Store contains more apps and user reviews than other platforms. Apps were selected using the following approach. First, a list was devised through a search of mathematics educational apps related to geometry. Apps on this list needed to explore and develop understandings of the spatial orientation and visualization

concepts defined in the literature section (see section 2.2.1). From this list of apps, a decision to consider an app was based on a number of factors. These included: (a) a *multi-representational dimension* (i.e., simultaneously seeing multiple representations) where visual elements could be manipulated and moved (Alagic & Palenz, 2006; Hennessy et al., 2001; Mayer, 2002; Stylianou, Smith, & Kaput, 2005; Suh et al., 2005; Zbiek, Heid, Blume, & Dick, 2007), allowing for aspects of embodied cognition (Nunez, 2004; Wilson 2002) to occur; (b) an aspect of *direct real-time feedback* (Leichtenstern, André, & Vogt, 2007) that assists students' understanding of the examples and non-examples (Chase & Abrahamson, 2015; Dove & Hollenbrand, 2014; Kazak, Wegerif, & Fujita, 2015); (c) a challenge aspect (Jorgensen & Lowrie, 2012) or game-like structure that encourages challenges and increased difficulty; and (d) open-ended activities where students are allowed free-play exploration of manipulatives without a directed task and opportunities to notice the invariance of objects as they manipulate them (Battista, 2008). The vast majority of apps that focused on drill and practice were avoided (Highfield & Goodwin, 2010). Finally, the apps had to include elements that were easily reproduced with physical manipulatives. Thus, each virtual lesson was matched to physical material that emphasised the same concept and required students to engage in similar types of tasks with these materials.

Table 3.3 illustrates how one of these lessons was matched for the two different classes (PM class and VM class). The particular aim in the development of these lessons was to ensure consistency of learning for the two groups of students. A comprehensive review of how all lessons were matched can be found in Appendix F.



Table 3.3

Example of How Lessons Were Matched – Lesson 1 SO: Point of View

Parts of lesson	Concrete (PM) lesson	Virtual (VM) lesson
Orientate (review of previous lesson)	Whole class, explicit teaching of position language (e.g., in front of, behind, in between, left, right, etc.). Students are asked to move into different positions (e.g., stand behind the chair; put the chair on the left-hand side of the desk).	Whole class, explicit teaching of position language (e.g., in front of, behind, in between, left, right, etc.). Interactive whiteboard activity of students positioning a virtual object into different positions within a model on screen.  ( <a href="http://www.iboard.co.uk/iwb/Naming-Positions-The-Picnic-677">http://www.iboard.co.uk/iwb/Naming-Positions-The-Picnic-677</a> and <a href="https://www.tes.co.uk/teaching-resource/position-them--the-picnic-6032389">https://www.tes.co.uk/teaching-resource/position-them--the-picnic-6032389</a> )
Enhance: Explicit Modelling	Using similar words and explanations to those used in the app, in pairs students explore how objects look when moved closer to or further away from a person looking at the front view of various 3D shapes.  Students explore different views of 3D objects from different viewpoints (front, back and side).	Exploration of the app “P.O.V.” ( <a href="https://itunes.apple.com/au/app/p.o.v.-spatial-reasoning-game/id532611500?mt=8">https://itunes.apple.com/au/app/p.o.v.-spatial-reasoning-game/id532611500?mt=8</a> )  In pairs complete the “Intro & Explore” section of the app.  Discuss: What happens when you move objects closer to the camera? etc.
Enhance: Guided Application	Rearrange the 3D shapes on a table. Working in pairs, ask children to describe/draw from different viewpoints. Ask them to move one object and talk about the difference in the picture.  While looking at objects from the front: Draw what you think they will look like from the back. In pairs, check your answers.  While looking at objects from the front: Draw what you think they will look like from the side. In pairs, check your answers.  (Discuss: What was difficult/easy? What things helped you?)	Students, in pairs, complete the activity in the app:  - Vantage Point (Discuss: What was difficult/easy? What things helped you?)  Which camera angle is the top picture from?  - Make a Scene (Discuss: What was difficult/easy? What things helped you?)  From the highlighted camera angle, make the camera view picture by moving the shapes into the correct position. The sneak view shows you what it looks like at the moment.
Synthesise	What did you learn? Do objects look the same from different positions? Why? What skills are we using to do this? Can you imagine objects in your head from different points of view?	What did you learn? Do objects look the same from different positions? Why? What skills are we using to do this? Can you imagine objects in your head from different points of view?

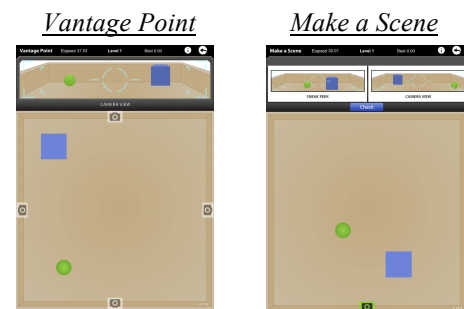

### 3.6 DATA COLLECTION PROCEDURES

Data collection occurred over several stages and included the use of observations, journal and field notes, pre- post- and post-post-testing students' spatial thinking using the spatial testing material, and video recordings of teaching experiments to analyse the interactions between teacher and students. The data collection comprised five stages occurring over a nine-month period. Each stage occurred at different times throughout the research, and each served different purposes in gaining insights into the research problem. An overview of the data collection procedure is presented in Table 3.2, and includes the timeframe, purpose, instrument used, data collection method, data analysis method and purpose of the analysis within each stage. The purpose of Stage 1 and Stage 2 was to gather baseline data prior to the commencement of the teaching experiments.

In Stage 1, the researcher observed students' interactions within the PM and VM classes. These observations occurred over a one-week period. This was essential as it helped build relationships and rapport with the students and classroom teachers prior to the commencement of the teaching experiments (Seidman, 2012). The researcher kept a journal of field notes about students and their interactions within the classroom context. A brief meeting with the teachers from School A ensured that no teaching of geometry or spatial concepts occurred in the period prior to or during the teaching experiment period. School B was informed that teaching instruction during the same period was to continue as normal, covering content prescribed by the Australian curriculum. As noted by Lowrie et al. (2017), this is an applicable approach used within intervention based teaching experiments. This was particularly pertinent for the class from School B, which was not participating in the teaching experiments associated with this study and was classified as the control condition.

In Stage 2 (prior to the teaching experiments), four spatial instruments (SO, SV1, SV2 and SCK) were administered to all participating students ( $n = 68$ ). The tests were administered under test-like conditions (i.e., separated desks, independent completion with no collaborations with peers, etc.). Verbal instructions on how students were to complete the tests, with relations to test condition expectations, were given. Questions on the SCK were read out to all participants to ensure that the ability to read was not a factor in completing the spatial thinking items. Each class was administered the same tests consecutively on the same day. The duration for each test was approximately 20 minutes.

In Stage 3, the two different teaching experiments occurred in the two selected classrooms, PM class ( $n = 23$ ) and VM class ( $n = 27$ ) from School A. The associated lessons were delivered on the same day in each classroom in the same broad timeslot (e.g., before the

first break in teaching for the day). The teaching episodes took place over a two-week period in Term 4, 2014. A brief overview of the matched lessons administered in the PM class and the VM class is presented in Appendix G. Each week consisted of three 1-hour lessons. Three cameras were used to video record each lesson. One focused on the teacher to capture the teaching actions while the other two cameras focused on the students to capture their learning, including their communication and gestures.

In Stage 4 (after the teaching experiments), the four spatial instruments (SO, SV1, SV2 and SCK) were administered to all participating students ( $n = 68$ ). This occurred using the same procedure as in Stage 2.

In Stage 5, the four spatial tests were readministered to students in the PM class and the VM class from School A, the two classes that participated in the teaching experiments. This occurred six months after the completion of the teaching experiment. The aim of this testing was to ascertain students' long-term retention of the content covered in the teaching experiments. As this six-month period incorporated the final two weeks of school for the year, the seven-week summer school holidays and the first term of the following year, these students experienced limited exposure to geometry and spatial concept lessons during this time. After the post-testing, debriefing with the classroom teachers occurred. The researcher shared all activities that had occurred in each of the three classrooms to ensure that no single class, teacher or school was disadvantaged.

### 3.7 DATA ANALYSIS

#### 3.7.1 Quantitative data analysis

All data collected from the pre-tests, post-tests and post-post-tests of the four spatial tests (Stage 2, Stage 4 and Stage 5) were entered into a statistical data program for analysis. Table 3.4 illustrates the data collected from each class.

Table 3.4

*Data Collected from Each Class*

	PM	VM	Control
Pre	✓	✓	✓
Post	✓	✓	✓
Post-post	✓	✓	

Pre-test, post-test, and post-post-test data were comparatively analysed to examine differences that existed between all three classes (i.e., PM class, VM class, and Control class). Analysis of the quantitative data occurred in three stages: analysis of pre-test results; analysis of post-test results; and analysis of post-post-test results. Analysis with the pre-test results began with examining the descriptive statistics of the three groups. To determine the comparability of the three groups, a one-way analysis of variance (ANOVA) was conducted. This process was used to ensure that all classes began with similar scores on the spatial thinking measures.

Analysis of the post-test data commenced with an ANOVA procedure to examine the differences that existed between the classes. Further investigation occurred by conducting pairwise comparisons between all class combinations for all four tests. Paired t-tests were used on each class separately, to ascertain the significance of the differences between pre-test and post-test scores. Finally, analysis of post-post-test scores began with a one-way repeated measure ANOVA on the pre-test, post-test and post-post-test scores of the PM and VM classes. Again, pairwise comparisons were used to examine the different combinations between the various time periods of each test. Finally, an ANOVA was then conducted on the PM and VM class scores across the three time periods (i.e., pre-test, post-test, and post-post-test).

### 3.7.2 Qualitative data analysis

Analysis of the video-recording data, collected in Stage 3, occurred over three phases. Table 3.5 presents an overview of the analysis process for the qualitative data gathered.

Table 3.5

*Overview of the Analysis Process for the Qualitative Data*

Phase	Analysis process
Phase 1	Video recordings transcribed and dissected Peer debriefing
Phase 2	In-depth analysis Observation of “critical instances” Coded using Anghileri’s (2006) hierarchy of scaffolding practices
Phase 3	Analysed through a sociocultural perspective using Sfard’s (2001) commognitive approach Coding according to gesture classifications (McNeill, 1992) Focal analysis – pronounced, attended and intended focus Analysis of meta-discursive rules – who is speaking and relationship between speakers Cross-analysis with Anghileri’s scaffolding practices SPSS analysis of coded items for scaffolding and gestures using Pearson’s chi-squared test

In the first phase, video recordings made during the teaching experiment lessons were transcribed and dissected, allowing the analysis of emerging themes that were observed at the

conclusion of each day. These were combined with any field notes that were gathered for the day. Peer debriefing occurred with both the classroom teacher and supervisors to determine consistency with regard to noticed themes. Appendix H presents a sample of the data analysis on the researcher’s field notes that occurred at the conclusion of this first stage.

The second phase allowed for a more in-depth analysis to occur at the conclusion of the data collection phase, where all video data were reanalysed. This required an iterative approach of reanalysis where continuous meaning making and progressive focusing occurred (Srivastava & Hopwood, 2009). Observation of “critical instances” occurred through a variety of lenses. Several key features assisted in interpreting the data gathered from the teaching experiments. Firstly, all of the teacher’s teaching interactions were coded using Anghileri’s (2006) hierarchy of scaffolding practices (see section 2.7.1.3). Presented in Table 3.6 are the codes for these scaffolding practices.

Table 3.6

*Coding Used for Anghileri’s Levels of Scaffolding Practices*

Scaffold level	Code	Scaffolding practice
Level 1 Environmental provisions	1A	Emotive feedback (words of approval or encouragement)
	1B	Peer collaboration
Level 2 Explaining, reviewing and restructuring	2Ex	Explaining (teacher telling)
	2RvA	Look, touch, verbalise (teacher asking student to do this)
	2RvB	Explain and justify (teacher asking student to do this)
	2RvC	Interpreting student actions (paraphrasing)
	2RvD	Prompting and probing questions (teacher asking)
	2RvE	Parallel modelling
	2RsA	Meaningful context (use of iconic gestures or creating real-life examples)
	2RsB	Simplifying the problem
	2RsC	Rephrasing students’ talk (using formal language)
	2RsD	Negotiating meanings
Level 3 Developing conceptual thinking	3A	Developing representational tools (language and objects used to create links to visual imagery)
	3B	Making connections (challenging student ideas, linking ideas)
	3C	Generating conceptual discourse (questions that start mathematical conversations)

Table 3.7 presents a sample of the data analysis that occurred in this second phase. The codes in the second column indicate who was speaking (e.g., T = teacher, S1 = student 1, C = class, I = iPad).

Table 3.7

*An Example of Analysis Using Scaffolding Coding*

Utterance	Verbal communication	Scaffolding	
30	T	What's a face?	2RvB (S explain)
31	S7	(a) Um on, on each side ... the ... (b) <b>flat</b> .... (c) you see there.	
32	T	I really like the, your, the words that you're using. You said the flat shape that you see on the side. Excellent. So the flat shape is a face? ... You see on the side. Okay?	1A (+ve feedback) 2RvC (paraphrase) 1A (+ve feedback) 2RsD (negotiate) 2RsA (context) 2RsD (negotiate)

In the third phase, the data were further analysed through a social perspective examining the interactions that occur between students and teachers or peers. This procedure occurred through the use of Sfard's (2001) commognitive approach to analysing mathematical discourse. Mathematical discourse, according to Sfard (2001), is influenced by two factors. The first factor relies on *communication-mediating tools*. These communication-mediating tools are what students use as a means of communication. They are seen as "part and parcel of the act of communication and thus cognition" (Sfard, 2001, p. 29). Communication-mediating tools included the mathematical words (i.e., oral language) and visual mediators (i.e., use of manipulatives and use of gestures) used by the participants. For this analysis to occur, a classification system for gestures needed to be used. McNeill's (1992) categories of gesture, plus two additional gesture classifications, were used to allow examination of the use of manipulatives (see section 2.7.2.2). Presented in Table 3.8 are the codes and a description of the gesture classifications used during the analysis of students' gesture use.

Table 3.8

*Coding for Gesture Classification*

Gesture classification	Code	Description
Grounding/embodiment gestures	GE	Any action where the student is physically interacting with the manipulative.
Changes to body positioning	BP	Bodily movements that change the position of a student's body.
Pointing gestures	G1	Context-dependent gestures, often used with deictic terms, such as <i>here</i> or <i>there</i> .. These are gestures where students use finger or whole hand motions towards an object (either real or imagined).
Iconic gestures	G2	Representational gestures that bear a resemblance to the concrete objects being referred to.
Metaphoric gestures	G3	Similar to iconic gestures as they make reference to a visual image; however, these images relate to abstract ideas.
Beat gestures	G4	Simple, non-pictorial gestures that include a repeating motion used to emphasise certain parts of utterances.

Table 3.9 presents a sample of the analysis that occurred in this third phase.

Table 3.9

*An Example of Analysis Using Scaffolding Coding and Gesture Coding*

Utterance	Verbal communication	Gesture (non-verbal communication)	Scaffolding
30 T	What's a face?		2RvB (S explain)
31 S7	(a) Um on, on each side ... the ... (b) <b>flat</b> ... (c) you see there.	(a) Hand on head (b) flicks hand towards teacher placed down flat (c) points whole hand towards model	G3 G2 G1
32 T	I really like the, your, the words that you're using. You said the flat shape that you see on the side. Excellent. So the flat shape is a face? ... You see on the side. Okay?	[S7 nods] Touches the faces of cube.	1A (+ve feedback) 2RvC (paraphrase) 1A (+ve feedback) 2RsD (negotiate) 2RsA (context) 2RsD (negotiate)

The second factor included observing particular *meta-discursive rules* that regulated the mathematical communication (i.e., implicit norms and specific ways of interacting). Therefore, analysis using Sfard's commognitive approach required two separate analyses: *focal analysis* and then *analysis of routines*.

To examine the effectiveness of students' communication a focal analysis was utilised. This analysis focused on interpreting the discourse that occurred. Sfard (2002a) claimed that mathematics discourse comprises three theoretical constructs: *pronounced focus*, *attended focus*, and *intended focus*. Pronounced focus are "the words used by the interlocutor to identify the object of her attention" (Sfard, 2001, p. 304) and attended focus "refers to what and how we are attending – looking at, listening to, and so forth – when speaking" (Sfard, 2001, p. 304). Thus, the analysis began with examining the actual words used by the students to focus their communication (the pronounced focus, what they said). The analysis then moved to capturing "what and how they were attending to when speaking" (the gestures and/or representations used to describe and identify the object of their attention – the attended focus). The intended focus "is the interlocutor's interpretation of the pronounced and attended foci. It is the whole cluster of experiences evoked by these other focal components as well as all the statements he or she would be able to make on the entity in question" (Sfard, 2001, p. 304). All three constructs help to discern (a) if effective communication (and thus learning) occurred in the mathematics lessons; and (b) whether the communication-mediating tools were being used in similar ways

within the mathematical discourse (Sfard, 2002a). Table 3.10 provides an example of focal analysis using pronounced, attended and intended focus.

Table 3.10

*An Example of Focal Analysis Using Pronounced, Attended and Intended Focus*

Utterance	Pronounced focus	Attended focus	Scaffolding	Intended focus
25 T	I want to know, firstly what does the word symmetry mean? (a) Or if you say something is symmetrical what does it mean?	(a) points index finger to hand	G3 2RsD (negotiate) 2RsD (negotiate)	Please define the word “symmetry”.
26 T	Can you tell me?		2RvA (context)	“Tell” means use your words to define it.
27 S29	It means something the same.			Being the <u>same</u> is part of the definition.
28 T	It means the same? Okay.		2RvC (paraphrase) 1A (+ve feedback)	So the word “same” is part of the definition; is there anything else?
29 S35	Something that you can (a) fold and it will look the same on both sides.	(a) brings left hand up slightly across body	G2 (1B)	If you <u>fold</u> it across like this, both sides will look the <u>same</u> .
30 T	Excellent. So that something when folded will look the same on both sides.		1A (+ve feedback) 2RvC (paraphrase)	Okay, so both sides of a folded piece of paper would look the same.
31 T	Anyone else want to say anything?		1B (peer)	This is not an exact definition but it is getting there. I still need some more information to successfully define “symmetry”.

Analysis of the *meta-discursive rules*, found in the routines used by the teacher and students, determined if students knew what to do in the mathematics lesson and how to do it. For example, when a person is greeted with “good morning”, appropriate responses may include “good morning to you, too” or “hi” or even a silent hand movement. It is within the system of meta-rules that people’s culturally specific norms, values and beliefs are encoded (Sfard, 2001). From these meta-discursive rules, communication could be judged as effective if it fulfilled its purpose, and evoked a reaction that was in line with the speaker’s meta-discursive expectations. For this reason, meta-discursive rules are examined through Sfard’s characteristic of discourse known as routines. To examine the *meta-level rules* (i.e., whether students are communicating



with self or others, and communicating about mathematics or not), which also includes the way the interaction is being managed and the relationship between interlocutors, examination of *the teacher–learner agreement* occurred. Presented in Table 3.11 is an example of how meta-level rules were analysed. The filled-in dot denotes who is speaking in that utterance, while the black line shows who they are speaking to.

Table 3.11  
*Meta-Level Rules Analysis of Teacher and Student Interactions*

Utterance	S29	T	S35
25	○	●	○
26	○	●	○
27	●	○	○
28	○	●	○
29	○	○	●
30	○	●	○
31	○	●	○

In utterance 25 the teacher was thinking aloud about the meaning of symmetry, therefore this is depicted by a black arrow (showing that it was mathematically related to the subject) pointed to herself. Utterance 26 continues with a question to students (i.e., “Can you tell me?”), which is represented by a black line towards each student. Utterance 27 shows that S29 responded to the teacher’s question. In Utterance 29, S35’s response was directed at both the initial speaker (S29) and the teacher. From this analysis, it can be seen that the teacher was leading the discussions, and the students were merely responding to questions, rather than generating discussions themselves. These analyses were used to distinguish the relationships between speakers, especially in relation to who was leading the discourse (i.e., an aspect of the teacher–learner agreement). This was an important factor when analysing routines and is discussed thoroughly in Chapter 6.

Finally, a cross analysis occurred, using Anghileri’s scaffolding practices, to identify key scaffolding practices that influenced students’ spatial thinking. This process allowed for the multiple perspectives that make up the learning to be analysed. The video recording of each lesson provided case study stories of each experimental classroom. Analyses occurred on each of the four phases of the lesson (i.e., Orientate, Enhance: Explicit Modelling; Enhance: Guided Application; and Synthesise) and were used to observe changes in the teacher and students’ mathematical discourse over the course of a lesson. The similarities and differences between the six lessons were also analysed. In particular, Lesson 3 from both PM and VM classes was

observed to compare the use of different scaffolding practices. Appendix I presents a visual comparison of this lesson and the scaffolding practices used throughout the whole lesson. The teacher and students' use of mathematical words and visual mediators in Lesson 3 were also comparatively analysed. Pearson's chi-squared test was used to analyse the trends in the frequency of mathematical words and visual mediators used by both the teacher and the students. The results of this analysis are presented in sections 4.3.3, 4.3.4 and 5.3.1.

## **3.8 TRUSTWORTHINESS**

### **3.8.1 Establishing trustworthiness with the quantitative data**

As indicated earlier in the chapter, the quantitative data meet the criteria for validity and reliability for all spatial testing materials administered to students. The tests included three factor-referenced cognitive tests as previously published by Ekstrom and colleagues (1976) measuring students spatial thinking (i.e., SO – Spatial Orientation Test; SV1 – Spatial Visualisation Test 1; and SV2 – Spatial Visualisation Test 2). Construct validity has been established with these tests, and they are commonly used in both education and education psychology research. The fourth test, SCK, measured students' spatial content knowledge, mirroring the national numeracy test items. Face validity occurred by mathematics professionals examining, scrutinising, and making comments or recommendations with regard to the chosen items. In addition, content validity was established through the use of existing NAPLAN testing items. These items have already been established by the Australian Council for Educational Research (ACER) and tested on large cohorts of students of a similar age. In addition, the current mathematics curriculum materials were examined to ensure alignment of the items.

Reliability for these tests was ensured by all tests (pre-, post-, post-post) being administered under the same test conditions (i.e., separated desks, independent completion with no collaboration with peers, etc.). Verbal instructions on how students were to complete the tests, with reference to test condition expectations, were given at all stages of the research. Questions on the SCK test were read out to all participants to ensure that the ability to read was not a factor in completing the spatial knowledge items. Each class was administered the same tests consecutively on the same day (e.g., PV class, Monday morning, tests 1–4; VM class, Tuesday morning, tests 1–4; Control class, Wednesday morning, tests 1–4). The duration for each test was the same (20 minutes per test) across each stage of the study.

### **3.8.2 Establishing trustworthiness with the qualitative data**

Within interpretivist research, validation and reliability are determined by the trustworthiness of the data. Four criteria were used to ensure trustworthiness: credibility; dependability; conformability; and transferability (Lincoln & Guba, 1985). The researcher can claim trustworthiness of the data by applying these four criteria (Trochim, 2006).

Credibility is concerned with “how congruent are the findings with reality” (Merriam, 1998). The researcher employed a number of techniques to ensure credibility. “Persistent engagement” occurred by conducting a number of lessons where students were observed frequently and time was dedicated to collecting data and crosschecking misconceptions. Building a relationship with the students produced a consistent engagement with the class, enhancing the potential to gather rich data from the teaching experiment. Video recording of each lesson allowed for “persistent observation”. During the teaching experiments, observations on the teacher’s and students’ interaction with manipulatives, as well as observations on the language and gestures used in their spatial thinking, informed the researcher of the influences that physical or virtual manipulatives may have on students’ learning. By video recording the data, the researcher had the possibility of reviewing the data on numerous occasions. “Peer debriefing” occurred at the conclusion of each lesson with the supervisors of the study. Additionally, peer reviews (by other research colleagues and teachers) were conducted during the data collection stage. This allowed the opportunity for peers to critique and discuss the interpretation of the collected data from the teaching experiments. During the data analysis stage, once data were coded and themes were identified, peers crosschecked the analysis. This process by peer group enhanced the credibility of the research by ensuring no bias occurred (Cohen et al., 2007; Yin, 2003).

Dependability was achieved by (a) conducting an independent audit of the data by external reviewers (e.g., research supervisor) and specifically selected peers (Cohen et al., 2007); and (b) overlapping data-gathering strategies within the study (Shenton, 2004), which was completed through students’ testing scores on spatial testing material, and observation and analysis of classroom lessons and interactions.

Conformability is concerned with the researcher’s comparable concern for objectivity (Shenton, 2004). To begin with, an independent audit occurred during the data-gathering and data analysis stages of this study by the research supervisors. This process was used to eliminate criticisms of bias that are often of concern with qualitative research. Second, triangulation was used to reduce the researcher’s bias or subjectivity for preconceived notions within the study, by collecting both qualitative and quantitative data. Triangulation and peer reviews were used

to address the validity of the findings. By conducting these procedures, the researcher acknowledges that there can be multiple interpretations of a particular instance (Stake, 2005), and the possibilities of bias interpretations.

Transferability involves the ability to replicate the study and can be overcome by replicating in “multiple environments” (Gross, 1999). A limitation of this study was that it was bounded by context and time. However, rich descriptions allow the possibility to produce generalisations from the findings (Stake, 2005). Although this study was conducted and bound to one particular context, with a clear description of the context and a detailed description of the procedure followed, similar projects employing the same methods but conducted in different environments could add further significance to the study.

### **3.9 ETHICAL CONSIDERATIONS**

Collection of data did not commence until ethical procedures were completed. In line with Australian Catholic University Human Research Ethics Committee requirements, ethical clearance was obtained from the university (see Appendix J) before Brisbane Catholic Education (see Appendix K) and Education Queensland were approached. As per Education Queensland guidelines, permission to conduct a study within an Education Queensland school is obtained through the principal of the school. Both the Australian Catholic University and all education employing authorities granted permission to conduct the research in their schools.

As the study was based in a disadvantaged context, the researcher had an obligation to respect the participants in this study in regard to their rights, needs, values and desires (Creswell, 2008). The participants were invited to the study without coercion or pressure, and were permitted to withdraw from it at any point. An information letter was provided to and a letter of informed consent was obtained from (a) the school principals (for the case schools); (b) the teachers of each class; and (c) the parents/caregivers of the participating students. The letters clearly outlined the objectives of the study, how data would be collected and the timeframes of the study. Copies of the information letters and consent forms administered to the principals, teachers and student participants are presented in Appendix L through to Appendix Q. Data collection did not commence until all consent was obtained.

Once data collection commenced, identification of individual students was concealed to provide anonymity of students. This was ensured by providing a code for each student (e.g., S25 = Student 25). The data were stored according to Australian Catholic University guidelines and access was restricted to people authorised by the researcher. Copies of interview transcripts were made available to participants on request. To ensure that classes participating in the study

encountered no disadvantage, the researcher debriefed with class teachers at the conclusion of the study period to share the lessons that occurred in each of the three classes.

### **3.10 CHAPTER REVIEW**

The purpose of this chapter was to delineate and justify the research design of the study. The chapter began with an outline of the theoretical framework and the research design used for this study. Explanations regarding the use of an interpretative paradigm were based on sociocultural theory. As the study investigated a problem that occurs within a classroom context, a case study methodology with a quasi-experimental design was an appropriate approach to use. The chapter continued with a description of how participants were chosen. Data collection strategies included the use of spatial testing material and teaching experiments. The procedure for data collection was outlined and data analysis procedures were examined in depth. Trustworthiness of both the quantitative and qualitative data were considered, as well as the ethical procedures of the study. The following chapter reports on the data collected from the spatial testing material and the results of the first section of the analysis procedure, which involved analysing the teacher's use of scaffolding practises.



# Chapter 4: Findings – Spatial Thinking and Teaching

---

## 4.1 CHAPTER OVERVIEW

Presented in this chapter is the analysis of data related to the influence of physical manipulatives (PM) and virtual manipulatives (VM) on the teaching of spatial concepts. The findings pertaining to the influence that these manipulatives had on students' learning of spatial concepts in each classroom are presented in Chapter 5. The learning of students in the PM class and the VM class (herein referred to as the PM students and the VM students) was examined through their communication of their spatial thinking. Chapter 4 comprises two sections. In the first section, the findings of the three instruments used as measures of students' spatial thinking (published factor-referenced cognitive tests, Ekstrom et al., 1976) and the Spatial Content Knowledge instrument – an instrument purposefully designed for this research – are reported. Presented in the second section are the findings from the analysis of video data collected from teaching experiments. Each section begins with a brief background to each phase of data collection and analysis pertaining to that section. The chapter concludes with a summary of findings across the teaching episodes. Illustrated in Figure 4.1 is an overview of Chapter 4.



*Figure 4.1.* Overview of Chapter 4.

## 4.2 INFLUENCE OF PHYSICAL MANIPULATIVES AND VIRTUAL MANIPULATIVES ON STUDENTS' SPATIAL THINKING

### 4.2.1 Background to data collection and analysis

Throughout the study, four written instruments (see Appendices A–D) were administered to all students in the three participating classes (PM, VM and Control). The three factor-referenced cognitive tests were published instruments (Ekstrom et al., 1976), which measure students' spatial thinking through the Spatial Orientation Test (SO); Spatial Visualisation Test 1 (SV1); and Spatial Visualisation Test 2 (SV2) (see Appendices A–C). The fourth instrument was a Spatial Content Knowledge Test (SCK) devised using previous practice questions from NAPLAN testing materials (see Appendix D). The reason for the inclusion of a NAPLAN-like test was to give students the opportunity to demonstrate their spatial abilities in a format and context that was familiar to them. For the purpose of this analysis, this instrument (SCK) was split into three components. These components mirrored the three different dimensions of spatial thinking (Orientation, Visualisation 1 and Visualisation 2), and are referred to in the tables and the text as NO, NV1 and NV2.

The administration of these four instruments occurred at two different junctures: prior to the teaching experiments (pre-tests) and at the completion of the teaching experiments (post-tests). Additionally, students in the PM and VM classes participated in post-post-tests, which were administered six months after the completion of the teaching experiments. These six months were spread across the last two months of the school year, two months of summer holidays, and the first two months of a new school year. During this time, limited teaching of spatial concepts occurred (testimonies from teachers).

The next section presents the results of an analysis of students' responses. The analysis is presented in two distinct subsections: results for the three factor-referenced cognitive instruments (SO, SV1, SV2), and results for the three components of the SCK instrument (NO, NV1, NV2). These six components (SO, SV1, SV2, NO, NV1, NV2) are referred to as *measures*.

### 4.2.2 Pre-test results

Table 4.1 presents the results from the factor-referenced cognitive instruments (SO, SV1, SV2). The maximum scores for these three measures were SO = 42; SV1 = 20; and SV2 = 60. Table 4.2 presents the results from the three components of the SCK instrument (NO, NV1, NV2). The maximum scores for these three measures were NO = 11; NV1 = 9; and NV2 = 10.



Table 4.1

*Pre-Test Means and Standard Deviations of the Factor-Referenced Cognitive Measures (SO, SV1, SV2)*

Class	SO		SV1		SV2	
	M	SD	M	SD	M	SD
PM class ( $n = 23$ )	21.17	3.157	6.83	3.143	15.39	6.693
VM class ( $n = 27$ )	22.52	5.132	6.85	3.910	18.78	9.325
Control class ( $n = 18$ )	20.06	2.980	5.72	2.270	14.89	5.335

Table 4.2

*Pre-Test Means and Standard Deviations of the Spatial Content Knowledge Measures (NO, NV1, NV2)*

Class	NO		NV1		NV2	
	M	SD	M	SD	M	SD
PM class ( $n = 23$ )	3.87	2.302	5.04	1.894	4.30	1.490
VM class ( $n = 27$ )	3.74	2.194	5.07	2.401	4.37	2.003
Control class ( $n = 18$ )	2.78	1.263	4.72	1.526	3.56	1.580

An analysis of the data from the six measures administered as pre-tests revealed that students in all three classes achieved results of below 50% on four of the six measures. The exception was the SO test where the PM class and the VM class results were just above 50%. In addition, the PM and VM class results for the NV1 measure were also above 50%.

To determine the comparability of the three classes or groups (PM, VM and Control) a one-way analysis of variance (ANOVA) was conducted on the pre-test scores for all six measures. An ANOVA was chosen as it allows for the statistical comparison of mean scores of more than two groups.

The assumption that underpins the validity of the results of an ANOVA is that samples are obtained from populations of equal variance. Levene's test of homogeneity was conducted to test the variance between the three groups (PM, VM and Control). This test was applied to all sets of data presented in this section of the thesis. The results of Levene's test indicated that in some instances there was significant variance. It was conjectured that this was due to the fact that the sample size for the Control class from School B ( $n = 18$ ) was less than the PM ( $n = 23$ ) and VM ( $n = 27$ ) classes from School A. While there was variance between the control group and the other two classes, the variance between the PM and VM classes was not significant. When the variance was significant, Welch's  $F$ -ratio is reported. Welch's  $F$  is a more conservative version of the  $F$ -ratio designed to be accurate when the assumption of

homogeneity of variance has been violated (Field, 2009). Table 4.3 and Table 4.4 present the results from the ANOVA conducted on the pre-test results.

Table 4.3

*One-Way ANOVA of Pre-Test Results for the Factor-Referenced Cognitive Measures*

Measure	<i>F</i>	<i>p</i> (significance)
SO	Welch's $F(2,65) = 2.088$	.136
SV1	$F(2,65) = .766$	.469
SV2	$F(2,65) = 1.868$	.163

Table 4.4

*One-Way ANOVA of Pre-Test Results for the Spatial Content Knowledge Measures*

Measure	<i>F</i>	<i>p</i> (significance)
NO	Welch's $F(2,65) = 2.724$	.077
NV1	Welch's $F(2,65) = .252$	.779
NV2	$F(2,65) = 1.362$	.263

As there was no significant difference between pre-test scores for all three classes on all six measures, it was assumed that the three classes were at a comparable level of understanding of spatial concepts prior to the intervention (i.e., the implementation of the teaching experiment in the PM and VM classes).

### 4.2.3 Post-test results

On completion of the teaching experiment, post-testing procedures occurred with all students. An ANOVA was conducted to compare the results of the three classes for each of the six measures. Table 4.5 and Table 4.6 present the results from this ANOVA conducted on the post-test results.

Table 4.5

*One-Way ANOVA of Post-Test Results for the Factor-Referenced Cognitive Measures*

Measure	<i>F</i>	<i>p</i> (significance)
SO	$F(2,65) = 6.180$	.003*
SV1	$F(2,65) = .692$	.504
SV2	Welch's $F(2,65) = 4.196$	.022*

\*  $p \leq .05$

Table 4.6

*One-Way ANOVA of Post-Test Results for the Spatial Content Knowledge Measures*

Measure	<i>F</i>	<i>p</i> (significance)
NO	$F(2,65) = 3.389$	.040*
NV1	$F(2,65) = 3.770$	.028*
NV2	Welch's $F(2,65) = 3.783$	.031*

\*  $p \leq .05$ 

The analysis revealed that there was a significant difference between the classes (PM, VM and Control) on two of the three factor-referenced cognitive measures (i.e., SO and SV2) at the  $p < .05$  level. No significant difference was found on the SV1 measure. Results from the SCK instrument revealed that there was a significant difference between the classes on all three measures (i.e., NO, NV1 and NV2) at the  $p < .05$  level.

As significant differences occurred between the three classes for most of the measures, a post-hoc procedure was completed to explore any between-group differences. A post-hoc test consists of pairwise comparisons of all different combinations of groups. When Levene's test of homogeneity revealed equal variance between groups, Gabriel's post-hoc procedure was used. When Levene's test of homogeneity indicated there was variances between groups, a more conservative procedure, the Games-Howell post-hoc procedure, was used. There were no significant variances between the PM and Control classes or the PM and VM classes. Table 4.7 and Table 4.8 present the significant variances between the VM class and the Control class.

Table 4.7

*Significant Variances Between the VM and Control Classes for the Factor-Referenced Cognitive Measures Post-Tests*

Measure	Pair	Mean diff.	<i>p</i> value
SO	VM and Control	4.815	.002* (Gabriel)
SV1	–	–	–
SV2	VM and Control	8.296	.024*(Games-Howell)

\*  $p \leq .05$ 

Table 4.8

*Significant Variances Between the VM and Control Classes for the Spatial Content Knowledge Measures Post-Tests*

Measure	Pair	Mean diff.	<i>p</i> value
NO	VM and Control	1.741	.036* (Gabriel)
NV1	VM and Control	1.426	.028* (Gabriel)
NV2	VM and Control	1.278	.042* (Games-Howell)

\*  $p \leq .05$

The values of the mean differences indicated that for five measures the VM class performed better than the Control class. For these five measures the difference between the means was statistically significant.

#### 4.2.4 Paired t-test results (pre-test to post-test)

Paired t-tests were conducted to ascertain if there were differences between the pre- and post-test results for the three classes (PM, VM and Control). This analysis is used when there are matched pairs of data. In this study, all students participated in both the pre- and the post-test. In addition, Cohen’s *d* scores were calculated for paired t-tests where the differences between the pre- and post-test scores were significant. These scores report the magnitude of the teaching experiments’ effect. The values established for Cohen’s *d* (Cohen, 1988) for interpreting the teaching experiments’ effect size are 0.2 = small effect; 0.5 = moderate effect; and 0.8 = large effect. The following section reports the results of the paired t-tests in relation to the pre- and post-test data on all six measures. The average mean score is the difference between the mean of the pre-test (pre-mean) and the mean of the post-test (post-mean). Each class’s results were examined separately. Table 4.9 and Table 4.10 present the paired t-test results for the pre-test and post-test data for the PM class.

Table 4.9

*Paired Sample t-Test Results (Pre-Test to Post-Test) for the Factor-Referenced Cognitive Measures: PM Class (n = 23)*

Measure	Pre mean	Pre SD	Post mean	Post SD	Avg. mean	<i>t</i>	<i>p</i>	Cohen’s <i>d</i>	Effect size
SO	21.17	3.157	22.74	4.330	1.565	1.646	.114		
SV1	6.83	3.143	8.61	3.041	1.783	2.507	.020*	0.522	Moderate
SV2	15.39	6.693	19.09	12.321	3.696	2.152	.043*	0.448	Small

\*  $p \leq .05$

Table 4.10

*Paired Sample t-Test Results (Pre-Test to Post-Test) for the Spatial Content Knowledge Measures: PM Class (n = 23)*

Measure	Pre mean	Pre SD	Post mean	Post SD	Avg. mean	<i>t</i>	<i>p</i>	Cohen’s <i>d</i>	Effect size
NO	3.87	2.302	4.74	2.281	.870	2.647	.015*	0.551	Moderate
NV1	5.04	1.894	6.22	1.999	1.174	4.013	.001*	0.837	Large
NV2	4.30	1.490	4.91	2.485	.609	1.346	.192		

\*  $p \leq .05$

Analysis of the results indicated that there was a significant difference on two of the factor-referenced cognitive measures (i.e., SV1 and SV2;  $p < .05$ ) for the PM class. On these measures, the effect sizes were respectively moderate and small. Results from the SCK instrument revealed that there was a significant difference on two of the measures (i.e., NO and NV1). There was a moderate and large effect size respectively on each of these measures. Table 4.11 and Table 4.12 present the paired t-test results for the VM class.

Table 4.11

*Paired Sample t-Test Results (Pre-Test to Post-Test) for the Factor-Referenced Cognitive Measures: VM Class (n = 27)*

Measure	Pre mean	Pre SD	Post mean	Post SD	Avg. mean	<i>t</i>	<i>p</i>	Cohen's <i>d</i>	Effect size
SO	22.52	5.132	24.93	5.463	2.407	2.366	.026*	0.455	Small
SV1	6.85	3.910	8.85	3.666	2.000	4.064	<.001*	0.782	Moderate
SV2	18.78	9.325	23.63	14.486	4.852	2.951	.007*	0.567	Moderate

\*  $p \leq .05$

Table 4.12

*Paired Sample t-Test Results (Pre-Test to Post-Test) for the Spatial Content Knowledge Measures: VM Class (n = 27)*

Measure	Pre mean	Pre SD	Post mean	Post SD	Avg. mean	<i>t</i>	<i>p</i>	Cohen's <i>d</i>	Effect size
NO	3.74	2.194	5.19	2.617	1.444	3.706	.001*	0.713	Moderate
NV1	5.07	2.401	6.48	1.740	1.407	4.875	<.001*	0.934	Large
NV2	4.37	2.003	5.22	2.309	.852	2.671	.013*	0.514	Moderate

\*  $p \leq .05$

Results revealed a significant difference between the pre-test and post-test data on all six measures. The effect size ranged from small to large, with a moderate effect size occurring for four of the measures. Table 4.13 and Table 4.14 present the paired t-test results for the Control class.

Table 4.13

*Paired Sample t-Test Results (Pre-Test to Post-Test) for the Factor-Referenced Cognitive Measures: Control Class (n = 18)*

Measure	Pre mean	Pre SD	Post mean	Post SD	Avg. mean	<i>t</i>	<i>p</i>	Cohen's <i>d</i>	Effect size
SO	20.06	2.980	20.11	2.805	.056	.058	.955		
SV1	5.72	2.270	7.67	3.413	1.944	3.145	.006*	0.741	Moderate
SV2	14.89	5.335	15.33	4.715	.444	.354	.728		

\*  $p \leq .05$

Table 4.14

*Paired Sample t-Test Results (Pre-Test to Post-Test) for the Spatial Content Knowledge Measures: Control Class (n = 18)*

Measure	Pre mean	Pre SD	Post mean	Post SD	Avg. mean	<i>t</i>	<i>p</i>	Cohen's <i>d</i>	Effect size
NO	2.78	1.263	3.44	1.338	.667	2.380	.029*	0.561	Moderate
NV1	4.72	1.526	5.06	1.434	.333	.900	.381		
NV2	3.56	1.580	3.94	1.056	.389	.923	.369		

\*  $p \leq .05$

Results revealed a statistically significant difference for one of the factor-referenced cognitive measures (SV1). There was a moderate effect size for this measure. Results also indicated that for the SCK instrument a statistically significant difference occurred for one of the measures (NO). There was a moderate effect size for this measure. Therefore, generally, students in the Control class did not make the same improvements as students from the PM and VM classes.

Overall findings from the paired t-tests revealed that the PM class made statistically significant gains in four of the measures: SV1, SV2, NO and NV1. The VM class made statistically significant gains on all six measures. In contrast, the Control group only made statistically significant gains on two measures, SV1 and NO. As the Control class did not make the same gains from pre-test to post-test as the other two classes, the results indicate that a teaching experiment using external representations (either PM or VM) had a positive effect on students' spatial thinking development. Comparison of the results for students from the PM and VM classes indicates that, while students in both classes made significant improvements on four and six of the measures respectively, the overall effect size for the improvement was greater for students in the VM class.

#### 4.2.5 Retention of understanding

A one-way repeated measure ANOVA was conducted to compare the scores on each measure at the pre-test (prior to teaching experiments), post-test (following the teaching experiments), and post-post-test (six-month follow-up) for the PM and VM students' results. Table 4.15 presents the mean and standard deviation for the factor-referenced cognitive measures and Table 4.16 presents the mean and standard deviation for the SCK measures across the three testing time periods for the PM students' results.

Table 4.15

*Mean and Standard Deviation of the Factor-Referenced Cognitive Measures on the Three Different Occasions (Pre-Test, Post-Test, and Post-Post-Test): PM class (n = 23)*

Measure	Pre-test (Time period 1)		Post-test (Time period 2)		Post-post-test (Time period 3)	
	Mean	SD	Mean	SD	Mean	SD
SO	21.17	3.157	22.74	4.330	24.35	5.399
SV1	6.83	3.143	8.61	3.041	9.17	2.980
SV2	15.39	6.693	19.09	12.321	19.65	13.982

Table 4.16

*Mean and Standard Deviation of the Spatial Content Knowledge Measures on the Three Different Occasions (Pre-Test, Post-Test, and Post-Post-Test): PM class (n = 23)*

Measure	Pre-test (Time period 1)		Post-test (Time period 2)		Post-post-test (Time period 3)	
	Mean	SD	Mean	SD	Mean	SD
NO	3.87	2.302	4.74	2.281	5.00	2.256
NV1	5.04	1.894	6.22	1.999	6.43	1.502
NV2	4.30	1.490	4.91	2.485	5.00	2.431

Table 4.17 and Table 4.18 present the Wilk's Lambda value, *F*-ratio, and *p* value of each measure for the PM class.

Table 4.17

*One-Way Repeated Measure ANOVA Values for Factor-Referenced Cognitive Measures: PM Class*

Measure	Wilk's Lambda	<i>F</i>	<i>p</i>
SO	.747	$F(2,21) = 3.552$	.047*
SV1	.640	$F(2,21) = 5.895$	.009*
SV2	.819	$F(2,21) = 2.322$	.123

\*  $p \leq .05$

Table 4.18

*One-Way Repeated Measure ANOVA Values for Spatial Content Knowledge Measures: PM Class*

Measure	Wilk's Lambda	<i>F</i>	<i>p</i>
NO	.526	$F(2,21) = 9.468$	.001*
NV1	.449	$F(2,21) = 12.878$	<.001*
NV2	.857	$F(2,21) = 1.745$	.199

\*  $p \leq .05$

These results indicate that there was a statistically significant effect of time for two of the factor-referenced cognitive measures (i.e., SO and SV1) and for two of the SCK measures (i.e., NO and NV1) for the PM students' results.

To ascertain where these statistically significant differences occurred, a pairwise comparison was conducted. The pairwise comparison compares each pair of time points and indicates where significant differences occur. Table 4.19 presents only the significant values between each pair of time points for the factor-referenced cognitive measures and their effect size. Table 4.20 presents only the significant values between each pair of time points for the SCK measures. Cohen's *d* was only calculated when the difference between the two groups was statistically significant.

Table 4.19

*Pairwise Comparison Significant Values for Factor-Referenced Cognitive Measures: PM Class*

Measure	Pre-test to post-test (1–2)		Post-test to post-post-test (2–3)		Pre-test to post-post-test (1–3)	
	<i>p</i>	Cohen's <i>d</i>	<i>p</i>	Cohen's <i>d</i>	<i>p</i>	Cohen's <i>d</i>
SO	.114		.346		.037*	0.579 (mod.)
SV1	.020*	0.522 (mod.)	1.000		.006*	0.727 (mod.)

\*  $p \leq .05$

As reported in Table 4.9, students in the PM class exhibited statistically significant gains from the pre-test to the post-test only for SV1 and SV2. In Table 4.19, of particular interest is the statistically significant difference between students' pre-test scores and post-post-test scores (occasions 1–3) for SO. This indicates that the development of this particular type of spatial thinking may require time to occur.

Table 4.20

*Pairwise Comparison Significant Values for Spatial Content Knowledge Measures: PM Class*

Measure	Pre-test to post-test (1–2)		Post-test to post-post-test (2–3)		Pre-test to post-post-test (1–3)	
	<i>p</i>	Cohen's <i>d</i>	<i>p</i>	Cohen's <i>d</i>	<i>p</i>	Cohen's <i>d</i>
NO	.015*	.551 (mod.)	1.000		.001*	0.929 (large)
NV1	.001*	.837 (large)	1.000		<.001*	0.989 (large)

\*  $p \leq .05$

The results for the pre-test to post-post-test (occasions 1–3) indicate that the statistically significant gains made by students between the pre-test and post-test for NO and NV1 measures (see Table 4.10) were maintained over the course of the study. In addition, for the NO the Cohen's *d* changed from moderate to large.



A one-way repeated measures ANOVA was conducted on the VM results across the three different time periods. Table 4.21 and Table 4.22 present the VM class means and standard deviations of the factor-referenced cognitive measures and SCK measures respectively.

Table 4.21

*Mean and Standard Deviation of the Factor-Referenced Cognitive Measures on the Three Different Occasions (Pre-Test, Post-Test, and Post-Post-Test): VM Class*

Measure	Pre-test (Time period 1)		Post-test (Time period 2)		Post-post-test (Time period 3)	
	Mean	SD	Mean	SD	Mean	SD
SO	22.52	5.132	24.93	5.463	24.93	5.656
SV1	6.85	3.910	8.85	3.666	9.07	4.187
SV2	18.78	9.325	23.63	14.486	24.33	15.802

Table 4.22

*Mean and Standard Deviation of the Spatial Content Knowledge Measures on the Three Different Occasions (Pre-Test, Post-Test, and Post-Post-Test): VM Class*

Measure	Pre-test (Time period 1)		Post-test (Time period 2)		Post-post-test (Time period 3)	
	Mean	SD	Mean	SD	Mean	SD
NO	3.74	2.194	5.19	2.617	5.07	2.303
NV1	5.07	2.401	6.48	1.740	6.70	1.857
NV2	4.37	2.003	5.22	2.309	5.44	2.326

Table 4.23 and Table 4.24 present the Wilk's Lambda value,  $F$ -ratio, and  $p$  value from the VM class for the factor-referenced cognitive measures and the SCK measures respectively.

Table 4.23

*One-Way Repeated Measure ANOVA Values for the Factor-Referenced Cognitive Measures: VM Class*

Measure	Wilk's Lambda	$F$	$p$
SO	.771	$F(2,25) = 3.703$	.039*
SV1	.466	$F(2,25) = 14.312$	<.001*
SV2	.747	$F(2,25) = 4.223$	.026*

\*  $p \leq .05$

Table 4.24

*One-Way Repeated Measure ANOVA Values for the Spatial Content Knowledge Measures: VM Class*

Measure	Wilk's Lambda	$F$	$p$
NO	.639	$F(2,25) = 7.067$	.004*
NV1	.494	$F(2,25) = 12.829$	<.001*
NV2	.711	$F(2,25) = 5.093$	.014*

\*  $p \leq .05$

Results indicate that there was a statistically significant effect for time on all six measures. To ascertain where these differences occurred, pairwise comparisons were conducted for all six measures. Table 4.25 presents the *p* values and effect sizes between each pair of tests for the factor-referenced cognitive measures in the VM class.

Table 4.25

*Pairwise Comparison Significant Values for the Factor-Referenced Cognitive Measures: VM Class*

Measure	Pre-test to post-test (1–2)		Post-test to post-post-test (2–3)		Pre-test to post-post-test (1–3)	
	<i>p</i>	Cohen's <i>d</i>	<i>p</i>	Cohen's <i>d</i>	<i>p</i>	Cohen's <i>d</i>
SO	.026*	0.455 (small)	1.000		.045*	0.501 (mod.)
SV1	.001*	0.782 (mod.)	1.000		<.001*	0.955 (large)
SV2	.007*	0.567 (mod.)	1.000		.040*	0.510 (mod.)

\*  $p \leq .05$

The statistically significant differences between pre-test and post-post-test (i.e., occasions 1–3) indicate that the statistically significant gains made by the VM students from the pre- to post-tests for these three measures (SO, SV1, SV2; see Table 4.11) were maintained over the course of the study. Additionally, the effect sizes for SO and SV1 respectively changed from small to moderate and moderate to large.

Table 4.26 presents the *p* values and effect sizes between each pair of tests for the SCK measures in the VM class.

Table 4.26

*Pairwise Comparison Significant Values for the Spatial Content Knowledge Measures: VM Class*

Measure	Pre-test to post-test (1–2)		Pre-test to post-post-test (2–3)		Post-test to post-post-test (1–3)	
	<i>p</i>	Cohen's <i>d</i>	<i>p</i>	Cohen's <i>d</i>	<i>p</i>	Cohen's <i>d</i>
NO	.001*	0.713 (mod.)	1.000		.012*	0.606 (mod.)
NV1	<.001*	0.938 (large)	1.000		<.001*	0.895 (large)
NV2	.013*	0.514 (mod.)	1.000		.027*	0.558 (mod.)

\*  $p \leq .05$

The statistically significant differences between pre-test and post-post-test (i.e., occasions 1–3) indicate that the statistically significant gains made by the VM students from the pre- to post-tests for these three measures (NO, NV1, NV2; see Table 4.12) were maintained over the course of the study.

#### **4.2.6 Summary of analysis of influence of PM and VM on students' spatial thinking**

The analysis of results presented in this section revealed that the use of external representations was beneficial to students' spatial thinking. This was concluded from the following evidence:

1. All classes (PM, VM and Control) experienced similar levels of spatial thinking before the teaching experiments commenced; this finding is based on results from the analysis presented in section 4.2.2 that indicated there was no statistically significant difference between the classes' pre-test scores.
2. Analysis of post-test results (see section 4.2.3) revealed a statistically significant difference between the VM class and the Control class on five of the six measures: SO, SV2, NO, NV1 and NV2. There was no significant difference between the PM and VM classes in regard to students' spatial thinking levels at the post-test stage. There was also no significant difference between the PM class and the Control class at the post-test stage.
3. Both the PM class and the VM class made statistically significant improvements on their spatial thinking scores from the pre-test to the post-test. The VM class made significant improvements on all six measures while the PM class made significant improvements on four of the six measures (i.e., SV1, SV2, NO and NV1). The Control class only made significant improvements on two measures (i.e., SV1 and NO). These results indicate that the Control class did not make the same improvements as the PM and VM classes. These results also indicate that although both the PM and VM classes made improvements between pre-test and post-test, overall the effect size for the VM class results was larger.
4. There were no statistically significant differences between the PM class and the VM class on the post-post-test results (see section 4.2.5). Further analysis revealed that neither class showed statistically significant differences between post-testing and post-post-testing results. These results indicate that the improvements these classes made in their spatial thinking from the pre-test to the post-test were maintained over a six-month period.

### **4.3 INFLUENCE OF REPRESENTATIONS ON THE TEACHING OF SPATIAL CONCEPTS**

#### **4.3.1 Background to the data collection and analysis**

The lessons for the teaching experiment were based on the types of spatial abilities reflected in the pre-established instruments used in the study. The two weeks of the teaching experiment were divided evenly into exploring the two overarching spatial abilities: spatial orientation and spatial visualisation (see section 3.5.2). Briefly, the first week (Lessons 1 to 3) focused on spatial orientation. These lessons explored students' spatial thinking related to (a) perceiving figures as a whole from different orientations, and (b) identifying objects when seen from different positions. The second week (Lessons 4 to 6) focused on spatial visualisation. These lessons explored students' spatial thinking related to mentally (a) reconstructing and deconstructing 3D objects, and (b) transforming spatial configurations. A comprehensive review of how these lessons were matched for the two different classes (PM and VM) is presented in Appendix E.

Initial analysis of observed lessons examined the teaching pedagogy utilised by the teacher. As this was directly related to effective teacher/student interactions, the scaffolding practices used by the teacher to support student learning were explored for this analysis.

The types and nature of scaffolding practices were analysed using Anghileri's (2006) hierarchy of scaffolding practices for mathematics learning (see Table 3.6). This approach allowed for a detailed analysis of how teaching scaffolds differed between the two classes according to the external representation used (i.e., physical or virtual manipulatives; see section 2.7.1.3). For ease of reference, a summary of Anghileri's levels of scaffolding practices is presented again in Table 4.27.

Table 4.27

*Anghileri's Levels of Scaffolding Practices*

Scaffold level	Code	Scaffolding practice
Level 1 Environmental provisions	1A	Emotive feedback (words of approval or encouragement)
	1B	Peer collaboration
Level 2 Explaining, reviewing and restructuring	2Ex	Explaining (teacher telling)
	2RvA	Look, touch, verbalise (teacher asking student to do this)
	2RvB	Explain and justify (teacher asking student to do this)
	2RvC	Interpreting student actions (paraphrasing)
	2RvD	Prompting and probing questions (teacher asking)
	2RvE	Parallel modelling
	2RsA	Meaningful context (use of iconic gestures or creating real-life examples)
	2RsB	Simplifying the problem
	2RsC	Rephrasing students' talk (using formal language)
	2RsD	Negotiating meanings
Level 3 Developing conceptual thinking	3A	Developing representational tools (language and objects used to create links to visual imagery)
	3B	Making connections (challenging student ideas, linking ideas)
	3C	Generating conceptual discourse (questions that start mathematical conversations)

The analysis of transcripts from the teaching experiments is presented in section 4.3.2. Section 4.3.2.1 presents the scaffolding practices used by the teacher in the PM class. On analysis of the transcripts, while there was some overlap between the scaffolding practices used by the teacher in the PM class and the VM class, there were many differences between the two classes. Section 4.3.2.2 focuses on presenting these differences and concludes with a summary of the comparison of the two classes.

### 4.3.2 Analysis of teacher's scaffolding

For the purpose of this study, each lesson was divided into four phases: Orientate; Enhance – Explicit Modelling; Enhance – Guided Application; and Synthesise (see section 3.5.2). Thus, the analysis of the video transcripts presented in sections 4.3.2.1 and 4.3.2.2 is organised under these four phases. The reporting of the vignettes extracted from the video transcripts conforms to the following structure:

- The title of each table includes which video the transcript has been taken from. For example, in Table 4.28,
  - **L1SV** – the first lesson (L1) of the spatial visualisation lessons (SV);
  - **PM 7** – video seven of all the PM video data collected for this lesson; and

- **Utterance 11–16** – the lines of the analysed transcript in video 7.
- The columns in each table consistently present
  - **Column 1** – the line of the analysed transcript (11 = line 11);
  - **Column 2** – who was speaking (T = teacher, S1 = student 1, C = class, I = iPad);
  - **Column 3** – pronounced focus (the verbal communication that occurred);
  - **Column 4** – attended focus (description of gesture used)
  - **Column 5** – coding of gestures (G1 = pointing gesture, G2 = iconic gesture, G3 = metaphoric gesture, G4 = beat gesture, GE = grounding/embodiment gesture, BP = body position); and
  - **Column 6** – coding of scaffolding practice that occurred.

#### ***4.3.2.1 Teacher scaffolding in the PM class lessons***

##### ***Scaffolding practices used in Phase 1 – Orientate***

In the Orientate phase, a major focus of teaching was on reviewing students’ previous knowledge through whole class discussion. As this phase was predominantly about ascertaining students’ prior knowledge and understandings, the teacher followed a review process that consisted of several scaffolds. A common structure used was to initially ask students to *explain or justify* (2RvB) their spatial concept understandings to their peers. To ensure whole class understanding of these ideas, the teacher then *paraphrased* (2RvC) students’ responses in conjunction with using a restructuring support by interacting with the physical material to create a *meaningful context* (2RsA). Finally, the teacher extrapolated further explanations from students through the use of *looking, touching or verbalising* (2RvA). This involved the teacher asking students to use the physical manipulative to “show or tell” their thinking.

Table 4.28 provides an example of the review process evident in the Orientate phase of the first spatial visualisation lesson. Students were exploring the features of 3D objects. The utterances prior to the vignette presented in Table 4.28 (Utterances 1–10) pertained to organising students for the lesson. The lesson began with the question, “How many squares do you need to make a cube?” (Utterance 9T) with S1’s response of “six” (Utterance 10S1). Presented in Table 4.28 is the classroom discussion that ensued after the student (S1) gave this response.

Table 4.28

*The Review Process Commonly Used in the Orientate Phase (LISV PM 7: Utterance 11–16)*

Utterance	Verbal communication	Gesture (non-verbal communication)	Scaffolding
11 T	How did you figure out you would need six squares?	Points to head	G1 2RvB (S explain)
12 S1	Um because I counted the faces		
13 T	You counted the faces? Can you show me how you counted the faces? What strategies would you use to count the faces of a cube?	Point to student	G2 2RvC (paraphrase) 2RvA (touch) 2RvA (verbalise)
14 T	So come over here so the class can see you as well. Show them how you counted them.	Positions students to the side of the cube	BP 2RvA (touch)
15 S1	I counted it as (a) one there, there would also be (b) one behind it, and at (c) the bottom, (d) also the top, and (e) the side, also (f) the other side.	(a) Touches the front (b) Touches behind (c) Touches bottom (d) Touches top (e) Touches left side (f) Touches right side	GE GE GE GE GE GE
16 T	So you did it in pairs? (a) So went this one there, there is also one there (b) That would make two (c) This one there, there is also one there (d) That would make another two (e) This one there then also make another one there (f) Make another two 3 lots of 2 makes 6 (g) That's a complex strategy but well done	(a) Touches front and back (b) Holds up 2 fingers (c) Touches bottom and top (d) Holds up 2 fingers (e) Touches left and right (f) Holds up 2 fingers (g) Pats student's shoulder	GE G2 GE G2 GE G2 GE 2Ex (T explain) 1A (+ve feedback)

In Table 4.28, the vignette began with the teacher asking S1 to explain how they knew how many 2D shapes were required to make a cube (Utterance 11). As the student responded with only a verbal communication, the teacher (Utterances 13 and 14) asked the student to “show” (i.e., touch the cube) to illuminate how they counted 6 squares. The teacher used the *look*, *touch*, *verbalise* (2RvA) scaffold so the student would model their thinking to their peers. Once S1 explained her thinking, using *grounding gestures* (GE) with the physical material (i.e., touching the physical material with her hand), the teacher paraphrased the student’s explanation (Utterance 16). Often throughout the scaffolding, the language and the gestures used by the teacher took on different scaffolding roles. For example, in Utterance 16, the language used by the teacher is *paraphrasing* (2RvC) the student’s response, while the gestures are providing a *meaningful context* (2RsA) by linking it back to the physical material. This paraphrasing helped to explicate the student’s actions to other students in the class. The teacher then proceeded to expand on the student’s response, with an explanation that potentially made the key characteristic of the response (i.e., 3 lots of 2 makes 6) unambiguous to other members of the class.

Occasionally, in this orientation phase, students used *special keywords* (i.e., the common mathematical vocabulary, such as *line, round, shape, edges*) when verbalising their prior knowledge. The teacher asked students to justify this terminology. This *negotiation of meaning* (2RsD) was conducted to ensure all students agreed upon the mathematical meaning for each of these words. In addition, when clarifying the meaning of special keywords, the teacher often used the physical materials to provide *meaningful context* (2RsA) for the special keywords. An example of this occurred in the same spatial visualisation lesson when S7 used the term *faces* in his explanation. The vignette relating to this example is shared in Table 4.29.

Table 4.29

*Negotiation of Meaning (2RsD) Scaffold (LISV PM 7: Utterance 30–32)*

Utterance	Verbal communication	Gesture (non-verbal communication)	Scaffolding
30 T	What's a face?		2RvB (S explain)
31 S7	(a) Um on, on each side ... the ... (b) <b>flat</b> .... (c) you see there.	(a) Hand on head (b) Flicks hand towards teacher placed down flat (c) Points whole hand towards model	G3 G2 G1
32 T	I really like the, your, the words that you're using. You said the flat shape that you see on the side. Excellent. So the flat shape is a face?... You see on the side. Okay?	[S7 nods] Touches the faces of cube.	GE 1A (+ve feedback) 2RvC (paraphrase) 1A (+ve feedback) 2RsD (negotiate) 2RsA (context) 2RsD (negotiate)

The student's response (Utterance 31S7) indicated that S7's verbal language skills were not proficient enough to allow him to provide an explicit answer to the question (Utterance 30T). In this situation, the student's use of gestures (iconic gesture G2 and pointing gesture G1) indicated a necessity to consolidate the meaning of the terminology used in this discourse. Therefore, restructuring of student learning occurred, first through *teacher-directed negotiation* (2RsD), and second by making this *meaningful in the context of the physical material* (2RsA).

### ***Scaffolding practices used in Phase 2 – Enhance: Explicit Modelling***

The Enhance: Explicit Modelling phase was highly dominated by the teacher *explain* (2Ex) scaffolding practice. The teacher acted as the “expert” or “authority” on the spatial topic. While verbal language was the main component of the teacher *explain* (2Ex) scaffolding practice, this scaffolding practice was often accompanied by teacher gestures that served the purpose of creating a visual *meaningful context* (2RsA) for students. Therefore, the teacher's capability of demonstrating the concept using PM played an important role in the mathematical discourse that occurred. Additionally, the teacher's *explain* (2Ex) scaffold was often used with *iconic* (G2)



gestures to represent the physical materials, or *grounding* gestures to ground students' thinking to the environment (GE).

Table 4.30 illustrates the role gestures played in the teacher's explanations. The vignette precedes the student task of using positional language to describe the different-coloured faces of a cube. The bolded sections found in column 3 (Verbal communication) indicate where the changes in the type of gestures used in relation to spoken words occurred. For example, in Utterance 9T, where the teacher says, "going to change the point of view you see", *beat gesturing* (G4) was occurring on each of these words.

Table 4.30

*Teacher Explanations (L2SO PM 6: Utterance 9–14)*

Utterance	Verbal communication	Gesture (non-verbal communication)	Scaffolding
9 T	It did look different because of lots of sides. When you hold it up from the front		2Ex (T explain)
	(a) it looked like this,	(a) Holding cube and cylinder	GE 3A (rep. tool)
	(b) but then when you looked at it from the back it looked like that didn't it. It changed sides so you need to keep that in	(b) Rotates body around so objects are on opposite sides.	GE 2RSA (context)
	(c) mind today when we're doing our activities that when	(c) Points to head	G1
	(d) you change positions it's	(d) With finger makes downward "c" motion away from body towards students	G2
	<b>(e) going to change the point of view you see.</b>	(e) Beats finger as each word said	G4
10 T	Okay, now the activity we are going to do today I need you to use		2Ex (T explain)
	(a) <b>all those</b> words we used yesterday like	(a) Circling motion of the hand (twice)	G3
	(b) in front of,	(b) Two hands, palms facing towards body, extended out from the body	G2 2RSA (context)
	(c) behind,	(c) Move both hands towards body	G2 2RSA (context)
	(d) top,	(d) One hand moved up, with palm facing down	G2 2RSA (context)
	(e) bottom, all that sort of stuff so you need to be able to use those words in relation to	(e) Leaving hand at the top, turns other hand so palm facing upwards	G2 2RSA (context)
	(f) where you see it.	(f) Hands at hip level, shoulder-width apart, palms facing each other	G2
11 T	Okay, and remember		2Ex (T explain)
	(a) <b>where you see</b> it	(a) One-handed cupped motion moving forward in 3 distinct beats	G2 2RSA (context)
	(b) is different	(b) Brings hand back to self	G2
	(c) depending on <b>where you're standing</b> , isn't it.	(c) One-handed cupped motion across the body from left to right in 3 distinct beats	G2 2RSA (context)

Utterance	Verbal communication	Gesture (non-verbal communication)	Scaffolding
12 T	Okay, so today we are going to each have a cube, you're going to work in pairs for me and you're going to have a cube.	Thumbs up	G3 2Ex (T explain)
13 T	Now what you're going to do is you're going to (a) put that cube  (b) down on your desk. It doesn't matter which one you put down.	(a) Holds up cube and places other palm out flat (b) Places cube on palm	GE 2RsA (context) G2 3A (rep. tool)
14 T	Then you're going to describe (a) with your partners, what it will look like from  (b) the top, (c) from the front, (d) from the back, and then (e) from the bottom.	(a) Unfolds hand out towards students with palm facing upwards (b) Touches top (c) Touches front (d) Touches back (e) Touches bottom	G2 2Ex (T explain) GE 3A (rep. tool) GE 3A (rep. tool) GE 3A (rep. tool) GE 3A (rep. tool)

First, the teacher's explanation (Utterance 9) involved the direct interaction with the concrete model to create a visual image. The aim of this action was to assist students to understand the notion of changing orientation. This action provided an opportunity for students to visualise, in a real-life *meaningful context* (2RsA), the spatial concept of changes in one's orientation (i.e., their point of view), and the resultant changes in the visual appearance of the concrete objects. As illustrated in Utterance 9T, these changes relied on the teacher's use of both *iconic* and *grounded* gestures (G2 and GE).

The transcript continues with the teacher further elaborating on the notion that changing one's orientation results in a change in the visual appearance of the concrete object (Utterances 10–14). Similarly, *iconic* and *grounded gestures* dominated this stage of the teacher's explanation. *Iconic gestures* were used to link the verbal language with a visual image of the orientation of the specific positional terminology used. For example, in Utterance 10, when the teacher said, "in front of", the *iconic gesture* used was two hands placed "in front of" an imaginary object. The aim of this gesture was to create a *meaningful context* (2RsA) for the spatial orientation terminology that corresponded with the appropriate face on the imaginary object. *Grounded gestures* were implemented to create a direct link to the *representational tools* (3A) used to explore the spatial concept. Presented in Utterance 14 is the teacher's use of the physical model of a cube to explain the positional language associated with corresponding faces. Thus, *iconic* and *grounding* gestures served two different scaffolding purposes: first, to *create meaningful context* (2RsA) in real-life experiences; and second, to serve as *representational tools* (3A) to foster links to students' own visual image of the physical material.

### *Scaffolding practices used in Phase 3 – Enhance: Guided Application*

As this phase was concerned with students' explanations and their capability of verbalising their conceptual understanding to others, the verbal language of students became the focus of analysis. To generate students' verbal communication, the teacher asked students to *verbalise* their thinking (2RvA). This was commonly achieved through *prompting and probing questions* (2RvD). A repetitive pattern of discourse followed after the student's response was received: the teacher *paraphrased* students' responses (2RvC); provided *feedback* on the response (1A); and continued the mathematical discourse by using another *prompting and probing question* (2RvD).

The vignette (Utterances 176T–185T) presented in Table 4.31 illustrates this repetitive pattern of discourse. This vignette was taken from the lesson that required students to use positional language to verbalise the position of different-coloured Lego bricks in relation to each other. The Lego bricks were randomly arranged on a table. The task began with students standing at one side of the table and looking at the Lego bricks from this perspective. This task was repeated, with each time students changing their orientation (the side of the table) from which they viewed the Lego bricks. The arrows down the side of column 6 (Scaffolding) indicate when the pattern of discourse is repeated.

In the transcript in Table 4.31, the *teacher initiation* (2RvA) occurs at Utterance 176T with an expectation of S14 verbalising her description of the Lego bricks. The student's response follows in Utterance 177S14. Finally, in Utterance 178T, the teacher *paraphrases* the student's response (2RvC) and provides positive feedback (1A) acknowledging the student's contributions to the discourse. The pattern of a *prompting and probing question* (2RvD) followed by *paraphrasing* (2RvC) is reinitiated by a new question being asked to continue mathematical discourse on the concept (2RvD).

Table 4.31

*Student Explanation (L3SO PM 1: Utterance 176–185)*

Utterance	Verbal communication	Gesture (non-verbal communication)	Scaffolding
176	T I need someone to help me describe what it's going to look like from that side.		2RvA (tell)
177	S14 .... (a) ..... (b)  (c) It's white.	(a) Hand up to mouth looking at the object (b) Brings hand down to a position that looks like going to cup/grab the object (c) Pinched fingers pointing at white block	G3 Student response G2 G1
178	T So it's white. Yup, and then purple, where?	Flat hand, palm facing down above Lego model	G1 2RvC (paraphrase) 1A (+ve feedback) 2RvD (question)
179	S14 (a) .... (b) Over there.	(a) Shakes left hand (b) Points to the left side	G2 Student response G1
180	T Where is the purple?	Brings other hand down to lay flat on other hand	G2 2RvD (question)
181	S14 On the left side.		Student response
182	T On the left side but is it (a) on top of the white or  (b) below the white?	(a) Taps top hand on top of other hand (b) Taps it underneath the hand	G2 2RvC (paraphrase) 2RvD (question) 2RsA (context) G2 2RsA (context)
183	S14 On top of it.		Student response
184	T On top of the white. Guys make sure you are <b>all</b> using the language okay?	Hold up index finger and circles around in a circle	G3 2RvC (paraphrase)
185	T So, you've got (a) <b>white</b> ....  (b) <b>purple on top</b> ....  What else can you see from the kangaroo's point of view?	(a) Right hand rest on top of left hand (b) Moves right hand up, about 5 cm, from the left hand	G2 2RvC (paraphrase) 2RsA (context) G2 2RsA (context) 2RvD (question)

When insufficient information was supplied in students' initial responses and further prompting and probing questions were necessary, the teacher used real-life *meaningful contexts* (2RsA) generated by iconic gestures to assist students to restructure their use of *special words*. This was illustrated in Utterance 182 in Table 4.31. The teacher also used *pointing gestures* (G1) as a visual link to the physical material being referenced in the language (Utterance 178). By *pointing* (G1) to the Lego bricks the teacher indicated that visual information could assist students to respond to the question. Finally, students used gestures as a cognitive structure to access the positional language required to facilitate the communication process.

When students experienced difficulties accessing appropriate terminology for the mathematical discourse, they used gestures to enhance their communication. This point is illustrated in Table 4.31 Utterance 177S14. The use of gestures by S14 was due to her inability to access the positional language or colour of the block as she tries to discuss the position of the Lego blocks from her current perspective. However, S14 then changes the gesture to pointing at the white block while successfully verbalising, “It’s white”. This suggests that the use of the gesture by this student helped her access the appropriate language (the colour of the block). This is further demonstrated in Utterance 179S14, where S14 shakes her left hand to help her demonstrate the word “left”. Unfortunately, on this occasion, she was not able to access the appropriate verbal communication and continues to engage in the discourse by pointing to the intended direction. The gestures used by students to assist their language in mathematical discourse were *grounding gestures* (GE); *iconic gestures* (G2) or *pointing gestures* related to inability to verbalise (G1).

During the Enhance: Guided Application phase, the teacher also identified students’ misconceptions. These were situations where students experienced difficulties in answering a question or explaining their thinking, or their ideas required challenging and correcting. In these instances, the teacher used scaffolding practices to help to restructure students’ conceptual misunderstandings. For example, if the prompting and probing questions proved unsuccessful the teacher’s scaffold changed to *simplification of the questions* (2RsB). If simplifying the question proved unsuccessful then the teacher attempted to restructure students’ understanding through the use of gestures linking to *real-life contexts* (2RsA) or *representational tools* (3A) to the physical material.

The vignette presented in Table 4.32 illustrates the use of these scaffolding practices. In this lesson, students were asked to use positional language to describe the position of three different 3D objects (pyramid, cylinder and rectangular prism). Each student had to verbalise the positions of these shapes from different orientations (e.g., front, back or side point-of-view).

Table 4.32

*Processes for Addressing Students' Misconceptions (LISO PM 8: Utterance 78–88)*

Utterance	Verbal communication	Gesture (non-verbal communication)	Scaffolding
78 T	Where is the pyramid?	Points to the pyramid	G1 2RvD (question)
79 S18	[silence]	Looks at the pyramid, eyes dart to the cylinder and then focuses back on pyramid Looks up to the teacher	
80 T	To the left or to the right from you?		2RsB (simplify)
81 S18	[silence]	Looks to other students for assistance	
82 T	So the, (a) the rectangular prism is to the right, or to the left? (b) ....	(a) Touches rectangular prism  (b) Touches pyramid	GE 2RsA (context) 2RvD (question) 2RsA (context)  GE
83 S18	..... (a)  Left?	(a) Student glances to other students	
84 T	Which way is left? ..... (a) .....  What is the answer?	(a) Turns so facing the same direction as the student and motions an “L” with left-hand forefinger and thumb	G2 3A (rep. tool)  2RvD (question)
85 S18	Right?		

To assist in the verbalisation process the vignette begins with the teacher asking a *prompting and probing question* (2RvD) (Utterance 78T). As this question did not generate the expected Initiation–Response–Follow-up (IRF) discourse sequence due to S18 experiencing difficulties, the teacher *simplified the problem* (2RsB) (Utterance 80T). She then used the physical material and gestures to connect to real-life examples (Utterance 82T). Finally, in order to help the student, the teacher tried to *create a representational tool* (3A) (Utterance 84T). The teacher showed that a person’s left hand makes an “L” with the thumb and forefinger to signify your left hand.

If the sequence of scaffolding practices (2RvD, 2RsB, 3A) was unsuccessful in assisting the restructuring of students’ understanding, the teacher cycled back to similar scaffolding strategies that were applied by the teacher in Phase 1, as illustrated in Table 4.33. In Lesson 3, students were using positional language to describe the orientation of Lego bricks.

Table 4.33

*Student Misconceptions Addressed Through Teacher Explain (2Ex) Scaffold (L3SO PM 1: Utterance 206–214)*

Utterance	Verbal communication	Gesture (non-verbal communication)	Scaffolding
206 T	So how did you know <b>where</b> everything was?	Taps the floor	GE 2RvB (explain)
207 S4	Umm ...	Moves head back down to floor level	BP
208 T	How'd you know where (a) <b>all</b> the colours were? What did you use to help you to know where to put everything?	(a) Moves hands around randomly like rearranging objects	G3 2RsB (simplify) 2RvD (question)
209 T	I'll <b>give you a clue</b> . (a)  (b)	(a) Raises both hands to either side of head (b) Lowers hands with palms facing upwards	G1 G1 2RsB (simplify)
210 S4	.... (a) ... Speaking?	Moves closer to look at model	BP
211 T	Yup. Speaking. When you speak in different words you can use, I knew (a) where everything was. So I can (b) colour that in now on my graph 'cause (c) you told (d) me (e) using what sort of words?	(a) Points to floor near model (b) Acts out colouring with a pencil (c) Points to student (d) Points to self	G1 G2 G1 G1 2RvD (question) 1A (+ve feedback) 2RvC (paraphrase) 2Ex (T explain)
212 S4	Above?	Moves closer to model	BP
213 T	(a) Excellent, very good. (b) You used  (c) above, (d) below and  (e) next to, so I  (f) knew exactly where  (g) you were talking about.	(a) Nods (b) Points to pinkie finger (c) Points to ring finger (d) Points to middle finger (e) Cups right hand around imaginary object (f) Motions left hand towards S4	G3 G2 G2 G2 G3 G1 1A (+ve feedback) 2Ex (T explain) 2RsA (context) 2RsA (context) 2RsA (context) 2RsA (context)
214 T	Well done! That's called positional language.		1A (+ve feedback) 2RsC (rephrase)

After a number of scaffolding attempts had been made to restructure the student's thinking, the teacher tried to simplify the question for the student (Utterance 208T). In Utterance 209T, the teacher used a *pointing gesture* (G1) to provide a visual cue and to help to simplify the language of communication. In Utterance 211T, even though S4's response was not what the teacher was asking for, the contribution was *positively acknowledged* (1A). The teacher followed S4's response with a short *explanation* (2Ex) of how the words used in speech assist

our understanding of where things are positioned. This explanation followed the format as presented in Phase 1, where the teacher used various gestures (G1 and G2) to *create meaningful contexts* (2RsA). The vignette concludes with the teacher *rephrasing* (2RsC) the student’s language and referring to the language used as “positional language” (Utterance 214T). It should be noted that the teacher’s use of *rephrasing* (2RsC) was not a common occurrence in the Enhance: Guided Application phase of the lessons.

***Scaffolding practices used in Phase 4 – Synthesise***

The Synthesise phase was designed to help students integrate their newly learnt understandings of particular spatial concepts with prior understandings. This was evident through the use of two different teacher-scaffolding practices: *rephrasing* (2RsC); and *developing conceptual thinking* (3A, 3B and 3C).

*Rephrasing* (2RsC) was the most evident scaffolding practice used in the Synthesise phase of the PM lessons. The teacher often paraphrased students’ responses to recognise the contribution of their ideas, and then *rephrased* incorrect terminology to reinforce a common understanding of *special keywords*. The vignette in Table 4.34 provides an example of how rephrasing was used by the teacher for this purpose. This example comes from a visualisation lesson on symmetry where students were engaged in tasks involving reflection.

Table 4.34

*Teacher’s Use of Rephrasing (2RsC) in the Synthesise Phase (L3SV PM 3: Utterance 21–25)*

Utterance	Verbal communication	Gesture (non-verbal communication)	Scaffolding
21 T	What would you have to do?	(No coded gesture – audio only: Teacher and students were out of video camera view)	2RvB (explain)
22 S22	Make, umm the opposite.		
23 T	So you would be thinking, “I’d have to make the opposite”. So the flip for the other side? Excellent. Anyone else, what would you be thinking in your head if you didn’t have the mirror to look into and get that reflection What would you be thinking to try and make that symmetrical?		2RvC (paraphrase)  2RsC (rephrase) 1A (+ve feedback) 2RvB (explain)
24 S17	Imagine the mirror is in front of me.		2RvB (explain)
25 T	So, you would imagine the mirror is there. You would visualise that the mirror is there and imagine what you would see? Excellent.		2RvC (paraphrase) 2RsC (rephrase)  1A (+ve feedback)

Utterance 23 illustrates how the teacher initially paraphrased S22’s original idea and then rephrased his answer to include the use of the *special keyword* “flip”. By providing an alternative word for the same concept (i.e., S22’s understanding of the word “opposite” was



better described as “flipped”), the teacher was able to extend S22’s vocabulary for future use in mathematical discourse.

The second scaffolding structure used in the Synthesise phase of the lesson involved developing students’ conceptual thinking through the following scaffolding strategies: *developing representational tools* (3A); *making connections by linking ideas* (3B); and *generating conceptual discourse* (3C). However, the successful use of these scaffolds was rare across the six PM lessons. Presented in Table 4.35 is a discussion that occurred in the Synthesise phase of a lesson about the comparison between features of 3D objects and their corresponding nets.

Table 4.35

*Teacher’s Use of Level 3 Scaffolds in the Synthesise Phase (L2SV PM 5: Utterance 40–42)*

Utterance	Verbal communication	Gesture (non-verbal communication)	Scaffolding
40 T	(a) Okay, so you think it’s that one.	(a) Picks up the 3D shape and places in front of student	GE 2RvD (question)
	(b) What made you think it was that one?	(b) Thumb and forefinger together on each hand	G2 2RvB (explain)
41 S9	(a) Triangles and uh ...	(a) Touches a triangle face	GE
	(b) bottom	(b) Points to the bottom face of the pyramid	G1
42 T	Excellent. So you’ve		1A (+ve feedback)
	(a) used the faces to	(a) Places right hand, open palm facing upwards on top of other hand	G2 2RsC (rephrase)
	(b) help you.	(b) Points with open palm right hand toward net	G1 3A (rep. tools)
	(c) So there’s four triangles and a square base,	(c) Taps open palm back on top of other hand	G2 3B (link ideas)
	(d) so therefore it’s that one. Excellent. Well done.	(d) Points open palm at net again	G1 3A (rep. tools) 1A (+ve feedback)

In Utterance 42T, after S9 has attempted to explain his thinking, the teacher:

1. acknowledges the student’s response by providing *feedback* (1A);
2. *rephrases* that response, using the *special keyword* of “faces” (2RsC);
3. uses the physical material (i.e., 3D objects and the corresponding nets) as *representational tools* (3A) for the formal 2D shape names of each face (e.g., triangles and square); and
4. begins the process of *making connections* (3B) back to S9’s original idea of matching faces on the physical materials.

The use of correct terminology, in addition to all the above, is required to successfully communicate the answer.

While the use of *developing representational tools* (3A) and *making connections* (3B) were generally successful in most Synthesise extracts, the use of *generating conceptual discourse* (3C) was often stilted. To continue the dialogue, the teacher used *prompting and probing questions* (2RvD) or asked students to *explain and justify* (2RvB) their response. Presented in Table 4.36 is the teacher’s attempt to continue the dialogue with students. During the previous phase of this lesson, students were asked to draw a representation of a Lego brick model onto grid paper from different orientations (e.g., front, top and side view). Students were also asked to verbally communicate their drawing to peers. The focus of this vignette was a discussion of how one’s position influences one’s drawing.

Table 4.36

*Teacher’s Attempt at Generating Mathematical Discourse (L3SO PM 7: Utterance 148–161)*

Utterance	Verbal communication	Gesture (non-verbal communication)	Scaffolding
148 T	(a) So, let’s have a look at this one here. If I told you, you had to colour that in on a piece of paper,	(a) Holds up model	GE 3A (rep. tool)
	(b) what’s the first thing you think of?	(b) Raises 1 finger high in the air	G2 3C (gen. discourse)
149 S14	Colours.		
150 T	Colours, and where the colours are. Excellent. Another thing you think of.		2RvC (paraphrase) 1A (+ve feedback) 2RvD (question)
151 S8	Colouring in the box.		
152 T	Which box? Where are you going to start?		2RvD (question) 2RvD (question)
153 S8	Um ...		
154 T	Where would you start?	Holds up piece of paper	GE 2RsA (context)
155 S8	From the top.		
156 T	(a) From the top. So, starting from the top, is, that’s how you think, you start from the top and (b) work your way down. Excellent. Anyone else got anything else they want to share?	(a) Points to the top grid on paper (b) Moves finger down the paper	G1 2RsA (context) 2RvC (paraphrase) G2 2RsA (context) 1A (+ve feedback) 3C (gen. discourse)

Utterance 152T illustrates the teacher’s use of *prompting and probing questions* (2RvD) in an attempt to continue the dialogue. This often resulted in students attending to an IRF discourse sequence identified in Phase 3 – Enhance: Guided Application of the lessons. Utterance 156T shows the teacher responding to Utterance 155S8 by paraphrasing S8’s response, using gesture to provide *meaningful context* (2RsA) for S8’s language. The teacher then provided positive feedback for S8’s contribution and again tried to *generate mathematical*

*discourse* (3C) with students. Students in the PM class did not seem to be at a level to independently continue these mathematical discussions.

### ***Summary***

The teacher, as researcher, implemented a number of different scaffolding strategies during the different phases of a lesson. While most of Anghileri's strategies were present in the PM lessons, the use of *parallel modelling* (2RvE) was not evident. As the six lessons used in the teaching experiment were developing different spatial concepts and were not a sequential unit of work based around one concept, the opportunity for this type of scaffolding did not present itself. Most occasions of modelling involved the teacher linking learning to *meaningful contexts* (2RsA) through *iconic* (G2) or *grounding gestures* (GE). As students' understandings of these spatial concepts were in the beginning stages of development, the use of such an abstract notion of *parallel modelling* appeared beyond the conceptual understanding of these students at this stage. It is also important to note that, as physical materials were the focus manipulative used in these lessons, the restructuring scaffold of *creating a meaningful context* (2RsA) was used in all four phases of the lesson (Orientate, Enhance: Explicit Modelling, Enhance: Guided Application, and Synthesise). Figure 4.2. summarises the results for these scaffolding structures applied by the teacher when teaching lessons using PM.

In the PM class, the Orientate phase consisted of a review process utilising various Level 2 reviewing scaffolding structures. This process allowed students to review their previous knowledge and understandings of the spatial concepts. Occasionally, the restructuring scaffold of *negotiating meanings* (2RsD) was used to develop consistent language use in these reviewing discourses.

In the Enhance: Explicit Modelling and Enhance: Guided Application phases, a sequence of scaffold use developed. Generally scaffolding structures followed the linear pattern of *explaining* (teacher explanation process) followed by *reviewing* (students' explanation and review of their learning) and then *restructuring* (modification of students' misconceptions). However, if students' misconceptions failed to be redressed at the *restructuring* stage, the teacher continuously cycled through *reviewing* and *restructuring*, until students ascertained the concept. If this cycling proved unsuccessful in correcting misconceptions, then the teacher went back to *explaining* and began the teaching process again from this first step. In this instance, *explaining* incorporated a heavy reliance on the restructuring scaffold of *creating meaningful contexts* (2RsA) to link the spatial concept to the physical manipulatives being used.

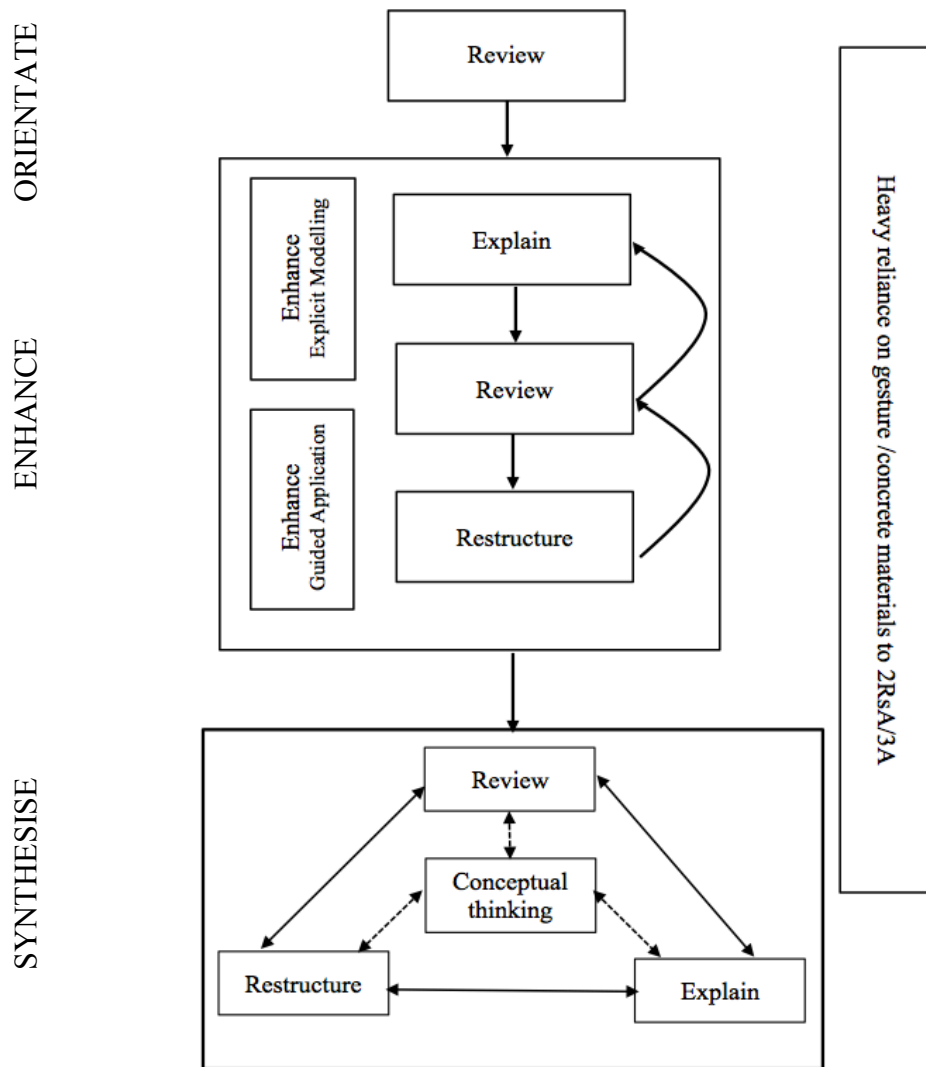

Figure 4.2. Summary of scaffolding practices applied to PM lessons.

Finally, in the Synthesise phase, the teacher began to implement Level 3 scaffolding structures to assist students’ development of conceptual thinking. Students in the PM class did not self-sustain these discussions and further teacher scaffolding was often required.

#### 4.3.2.2 Teacher scaffolding in the VM class lessons

While the lessons for the VM class were developed to follow a comparable format to the PM lessons (see Appendix F), adjustments were made to the scaffolding supports implemented as each virtual lesson progressed. The presentation of the analysis of the teacher’s scaffolding practices follows a similar structure to that used for the PM analysis (Phase 1 Orientate, Phase 2 Enhance: Explicit Modelling, Phase 3 Enhance: Guided Application, and Phase 4 Synthesise), with Phase 2 and Phase 3 being presented as one section. While the analysis revealed

similarities between the scaffolding practices used in the PM class and the VM class, there was a vast array of differences. Thus, the focus of this section is on presenting these differences.

The difference in the teacher and students' dialogue that occurred between the PM class and the VM class was the most evident difference. In the VM class, students were more responsive to initiating and continuing mathematical discourse. This finding is further elaborated on in all four phases of the lesson. Due to this change, the teacher subsequently implemented different types of scaffolding support structures or increased the frequency of previously used structures. In summary, the Orientate phase evidenced the teacher engaging students in increased Level 2 scaffolding practices of *restructuring* and increased use of Level 3 scaffolding to *develop conceptual thinking*. The Enhance phases (Phase 2 and Phase 3) resulted in a more dynamic application of teaching scaffolds due to the unique features of the virtual manipulative. During this phase, the applications on the iPad (VM) consisted of multimodal (i.e., visual and verbal) representations. In addition, the application assumed the "expert" role within the teacher explanation section and provided some Level 2 scaffolding practices. Finally, in the Synthesise phase, there was a change in the emphasis of the teacher's role. The teacher was less dominant in the scaffolding process. In the following subsections, evidence of the differences that occurred is presented.

### ***Phase 1 – Orientate***

Similar to the PM lessons, the VM lessons began with a review of students' prior learning (see Appendix F for the overview of lessons in the teaching experiment). The teacher attempted to replicate the Level 2 reviewing scaffolding practices (e.g., *explain or justify* – 2RvB; *paraphrase* – 2RvC; and *look, touch or verbalise* – 2RvA) that were used in the Orientate phase of the PM lessons. In the PM class, these reviewing scaffolding practices assisted students in communicating their understandings of concepts. However, in the VM lessons, the Orientate phase changed from simply using Level 2 reviewing scaffolding practices to incorporating more complex Level 2 and Level 3 scaffolding practices.

Five differences occurred in the types of scaffolding practices the teacher used in the VM lessons. These were:

1. the inclusion of Level 3 scaffolding practices to develop conceptual thinking;
2. a change of emphasis of the Level 2 restructuring scaffold practices used;
3. a change in the types of Level 2 explaining scaffolding practices used;
4. a change in the teacher's use of gesture; and

5. an increased emphasis on peer collaboration that involved students themselves using scaffolding practices with each other.

The findings for this phase are presented under these five identified differences.

### *Inclusion of Level 3 scaffolds*

In the VM lessons, the first difference the teacher observed related to students' willingness to share their understandings with both the teacher and each other. As a result, the teacher limited the use of asking students to *explain or justify* (2RvB) their thinking, and started to implement questions that would *generate mathematical discourse* (3C). Unlike the unsuccessful attempts of applying this higher-level scaffold in the PM class lessons, students in the VM class were more willing to initiate their participation in this discourse.

The vignette provided in Table 4.37 highlights the inclusion of Level 3 scaffolds in the reviewing process. It occurred during a spatial orientation lesson where students were reviewing their learning from the previous lesson. In the previous lesson, students used virtual images of coloured blocks to create various shapes. They were also required to view the shape from different orientations and use positional language to describe the images they saw. This discussion related to asking students to share how the application of the iPad assisted the development of their orientation skills.

Table 4.37

*The Inclusion of 3C Scaffolding (L3SO VM 9: Utterance 45)*

Utterance	Verbal communication	Gesture (non-verbal communication)		Scaffolding
45 T	(a) Can you people tell me how the	(a) Raises hand up like answering a question	G3	3C (gen. discourse)
	(b) iPad helped them	(b) Two hands over the iPad	G1	2RSA (context)
	(c) do their work	(c) Two hands moved from the iPad to the right of body	G3	
	(d) <b>on the paper?</b>	(d) Beats hands up and down for each word	G4	

Utterance 45T is an example of how the teacher invited all students to engage in *conceptual discourse* (3C) about how the iPad assisted their understanding of viewing objects from different orientations. Several students provided responses. One of the responses indicated that a student in the VM class physically rotated the iPad to view the shape from different orientations. By contrast, when the PM class were challenged with the same task, these students physically moved themselves to see the shape from different orientations (see Table 4.33). This continuation of dialogue showed that these students were more willing to engage in the

conceptual dialogue. As a consequence of this increased self-participation, the frequency of the use of *prompting and probing questions* (2RvD) diminished.

A further consequence of this increased participation in classroom dialogue was the teacher’s implementation of *making connections* (3B) scaffolds that challenged students’ ideas or provided links for students’ conceptual spatial thinking. As shown in Table 4.37, the teacher had implemented the scaffold, *generating mathematical discourse* (3C) (Utterance 45T). The teacher was then able to use this information to start *making connections* (3B) between many of the students’ generated ideas. Table 4.38 shows evidence of how a *making connections* (3B) scaffold was achieved.

Table 4.38

*The Inclusion of 3B Scaffolding (L3SO VM 9: Utterance 49)*

Utterance	Verbal communication	Gesture (non-verbal communication)	Scaffolding
49 T	It		2RvC (paraphrase)
	(a) helped you because you could	(a) Left hand out close to students and right hand close to body (like holding an imaginary ball)	G2
	(b) turn it around.	(b) Hands are rotated so right hand is further away and left hand is closer	G2
	(c) You didn’t have to physically turn the iPad around did you?	(c) Picks up iPad and rotates it around in hands	GE 3B (challenge) 2RsA (context)

In Utterance 49T the teacher, after acknowledging the student’s response by *paraphrasing* (2RvC) it, continued the dialogue by challenging the student’s idea that “we could turn it [the iPad] around”. The teacher sought clarification by asking, “You didn’t have to physically turn the iPad around did you?” The *grounding gesture* (GE), creating a *meaningful context* (2RsA), assisted the teacher to verbally probe the student’s response. As a consequence, the student re-evaluated his previous answer, and re-explained and clarified what he meant. It should be noted that the application of *making connections* (3B) was reliant on students’ willingness and ability to engage in conceptual discourse. If the students had not been as receptive to *generating conceptual discourse* (3C), the application of *making connections* (3B) may not have achieved the desired effect.

#### *Change of emphasis in Level 2 scaffolds*

The second observable difference related to students’ increased participation in classroom dialogue generated by the introduction of Level 3 scaffolds. As a consequence, many of the

students' misconceptions were identified early in the lesson. This section presents how the teacher addressed these misconceptions by implementing *restructuring* scaffolds.

In contrast to the PM lesson, every VM lesson in the Orientate phase contained the *negotiating meanings* (2RsD) scaffolding practice at least once. At the beginning of the lesson, when the teacher was reviewing students' prior learning, the teacher would ask for clarification of the terminology used by students. For example, if students were talking about symmetry, the teacher would ask them to define symmetry. Examples of questions used by the teacher to initiate this *negotiating meanings* (2RsD) scaffold included:

T: What's a face? Can anyone tell me what a face is on a 3D shape? (video data L1SV VM 1); and

T: What does the word symmetrical mean? (video data L3SV VM 3)

In addition, during the Orientate phase there was an increased opportunity for the teacher to implement the restructuring scaffold of *rephrasing* (2RsC). In the PM class lessons, no rephrasing occurred in the Orientate phase (see section 4.3.2.1). Presented in Table 4.39 is a vignette of transcript from a spatial orientation lesson highlighting the use of rephrasing in the Orientate phase. The lesson began with a discussion of how the iPad app assisted their spatial thinking related to viewing objects from different points of view. In the previous lesson, students created shapes by connecting various coloured cubes together. Students then had to describe to a partner the layout of the different coloured cubes from various points of view (e.g., front view, back view, top view).

Table 4.39

*The Use of Rephrasing (L3SO VM 9: Utterance 52–53)*

Utterance	Verbal communication	Gesture (non-verbal communication)	Scaffolding
52 S53	Moved the screen.		
53 T	So yep, (a) you dragged across the screen and it (b) <i>rotated</i> and (c) moved that (d) shape <b>around</b> so <b>you could see it</b> from different angles.	(a) Points to student (b) Right hand cupped like holding a ball and rotates thumb forward (c) Rotates hand backwards (d) Rotates hand in different directions for each bold word	1A (+ve feedback) G1 2RsC (rephrase) G2 2RsC (rephrase) G2 2RvC (paraphrase) G4 2RSA (context)

In Utterance 52S53, the student shared how the iPad had assisted his understanding of changing orientations. He stated that he “moved the screen”. The teacher *rephrased* (2RsC) this, in Utterance 53, and introduced the word *rotated* into the mathematical dialogue. This



introduction was accompanied with an appropriate iconic gesture (i.e., rotating a cupped hand forward and back) *creating a meaningful context* (2RsA).

The change in the emphasis of the *review* scaffolding practice reflected the different types of representations used in each lesson sequence. Due to the physical nature of PM, the teacher tended to ask students to “show” their thinking or to “touch” the physical material. With an absence of these physical materials in the VM class, the teacher tended to ask students to “tell” or “verbalise” their understandings of a spatial concept. An example from each spatial concept area (i.e., orientation and visualisation) is provided to show that this occurred:

4 T: Can anyone tell me what a face is on a 3D shape? (video data L1SV VM 1)

15 T: Have a look at it. Tell me where he is. (video data L1SO VM 1)

Therefore, the increased identification of students’ misconceptions, especially in students’ use of *special keywords*, led to an increase in the teacher’s use of *restructuring* scaffolds. The *restructuring* scaffolds that notably increased were *negotiating meanings* (2RsD) and *rephrasing* (2RsC).

#### *Change in the types of explaining scaffolds*

The third change to the Orientate phase related to the implementation of Level 3 support scaffolds and the increase of Level 2 restructuring scaffolds early in the VM lessons. These variations caused changes in the use of the *teacher explain* (2Ex) scaffold. This scaffold was only occasionally used in the Orientate phase of the PM lessons (see section 4.3.2.1). As students’ participation in discussion increased and more *restructuring* of students’ misconceptions occurred, there was also a greater need for the teacher to give further *explanations*. An example is presented in a vignette from a visualisation lesson where students were reviewing their understandings of the features of 3D objects. This included revising the definitions of faces, edges and vertices. In Table 4.40, a student was trying to explain the meaning of the term “edge” by indicating its position on a virtual model of a 3D shape. This virtual 3D model was displayed on the interactive whiteboard for the whole class to see. Prior to this vignette, when asked what an edge was, the student pointed to a vertex.

Table 4.40

*Change in the Types of Explaining Structures (LISV VM 1: Utterance 14–16)*

Utterance	Verbal communication	Gesture (non-verbal communication)	Scaffolding
14 T	That's a corner. Or vertices. Very good. That's a corner or vertices. That's another one that I want you to think about. Show me which, where the edges, go on. Go on, show me.		2Ex (T. explain) 1A (+ve feedback) 2Ex (T. explain)  2RvA (show)
15 S31	Along here	Runs finger along the bottom front edge of the cube and then the top front edge	GE GE
16 T	Okay, it's where (a) two faces meet. That makes an edge.	(a) Brings two flat hands together to meet together like two faces meeting at the edge	2Ex (T. explain) 2RsA (context)

The teacher *explained* (2Ex) to the student (Utterance 14T, Table 4.40) that the feature that he was pointing and referring to was in fact the vertex and not an edge. The teacher then offered another opportunity for the student to “show” (2RvA) where an edge was on the virtual model. When the student demonstrated a correct response through his use of grounding gestures (Utterance 15S31), the teacher continued to *explain* (2Ex) the definition of edge in Utterance 16T, thus endeavouring to ensure all students could differentiate between a vertex and an edge.

#### *Change in the teacher's use of gesture*

In the virtual lessons, the teacher's use of *iconic* gestures and *metaphoric* gestures increased when using the *meaningful context* (2RsA) scaffold. There were two different scenarios where *iconic* gestures were evident (see Table 4.41 and Table 4.42).

First, the teacher used *iconic* gestures to help students form a visual picture (in their mind) of the verbal explanation given. Table 4.41 illustrates how this occurred. In this visualisation lesson on symmetry, the teacher was explaining to the class how to identify where the line of symmetry was in a symmetrical pattern.

Table 4.41

*Iconic Gesture as a Visual Representation of a Verbally Communicated Idea (L3SV VM 6: Utterance 41)*

Utterance	Verbal communication	Gesture (non-verbal communication)	Scaffolding
41 T	A line of symmetry is (a) where it would fold,	(a) Two hands spread out wide with palms facing upwards (like a piece of paper) and brings palms together so touching	G2 2Ex (T. explain) 2RSA (context)
	(b) so where that	(b) Separates hands back out	G2 2RSA (context)
	(c) fold mark would be.	(c) Runs right index finger along the inside edge of the left palm (showing where the line of symmetry would be)	G2 2RSA (context)
	(d) You know if I folded a piece of paper	(d) Brings hands together again so touching	G2 2RSA (context)
	(e) and then unfold it,	(e) Separates hands again	G2 2RSA (context)
	(f) you have that line down the middle,	(f) Runs right index finger along the inside edge of the left palm again	G2 2RSA (context)
	(g) <b>that</b> is your line of symmetry. So <b>you</b> can <b>point out</b> to me <b>where that line of symmetry</b> would be on your thing.	(g) With thumb and index finger pressed together beats on each bold word	G4

In Utterance 41T(a)–(b), the teacher iconically represented the actions of folding a piece of paper, to create a symmetrical pattern. In Utterance 41T(c), the teacher uses another *iconic* gesture to indicate where the line of symmetry would be.

Second, the teacher used *iconic* gestures as a clarification tool when paraphrasing students' spatial ideas and understandings. Often, when paraphrasing students' responses, the teacher mimicked the *iconic* gestures used by students. Presented in Table 4.42 is a vignette from a spatial orientation lesson where a student had just finished explaining what they had done on the iPad in the previous lesson.

Table 4.42

*Iconic Gestures as a Clarifying Tool (L3SO VM 9: Utterance 42–43)*

Utterance	Verbal communication	Gesture (non-verbal communication)	Scaffolding
42 S42	We had to um, (a) um we had to write	(a) Raises hand to begin a gesture	G3
	(b) forward,	(b) Moves pointer finger forward away from body	G2
	(c) back,	(c) Moves hand back towards self	G2
	(d) top, and	(d) Raises hand slightly	G2
	(e) bottom and we had to	(e) Puts hand back down	G2
	(f) turn it around so we can see what difference does that show.	(f) Rotates hand around and back	G2

Utterance	Verbal communication	Gesture (non-verbal communication)	Scaffolding	
43 T	So, what it (a) looked like from those (b) different sides.	(a) Holding flat palm up (b) Curves hand back towards self	G3 G3	2RvC (paraphrase)
	So, from the (c) front,	(c) Flat hand at the front of imaginary object	G2	2RsA (context)
	(d) from the bottom, from the back.	(d) Drops pinched hand down	G2	2RsA (context)
	(e) Yes.	(e) Points to student	G1	

As illustrated in Utterance 42S42, the student produced *iconic* gestures to create a visual representation of the orientations that she had described. In Utterance 43T, the teacher *paraphrased* (2RvC) the student’s response. The teacher then created *iconic* gestures, similar to the ones used by S42 in Utterance 42S42. The production of *metaphoric* gestures (G3) also occurred. An example of this is evident in the beginning of Utterance 43T, where the teacher produced an “open book” like gesture for the word “look”, and a gesture of turning hands over to represent “different sides”.

*Students becoming active engagers in the scaffolding process*

The last observable difference in the Orientate phase of the virtual lessons related to students’ use of peer-scaffolding practices. These practices often occurred in the discussions and resulted in the teachers’ use of Level 3 scaffolding practices. Table 4.43 illustrates how students begin to peer-scaffold and develop deeper conceptual thinking. This accompanied the teacher’s use of the *negotiating meanings* (2RsD) scaffold. The transcript was taken from a spatial visualisation lesson about symmetry. As there was only one lesson on symmetry within the three spatial visualisation lessons, the *negotiating meanings* (2RsD) scaffold occurred multiple times throughout the Orientate phase of the lesson. The orientating activity, the iPad app “Symmetry Lab”, allowed students to explore aspects of symmetry. Students dragged their finger across the iPad screen and a symmetrical pattern was made using various colours (see Appendix F). In the discussion during this task, students were required to review their prior understandings of symmetry. The vignette begins with the teacher asking for a definition of the word “symmetry” (Utterance 25T). The dialogue that eventuated resulted in students providing *peer collaboration* (1B) to each other, to further clarify the definition of symmetry (Utterance 29S35 and Utterance 32S38).

Table 4.43

*Student Peer Scaffolding (L3SV VM 3: Utterance 25–33)*

Utterance	Verbal communication	Gesture (non-verbal communication)	Scaffolding
25	T	I want to know, firstly what does the word symmetry mean? (a) Or if you say something is symmetrical what does it mean?	(a) Points index finger to hand G3 2RsD (negotiate)
26	T	Can you tell me?	2RvA (context)
27	S29	It means something the same.	
28	T	It means the same? Okay.	2RvC (paraphrase) 1A (+ve feedback)
29	S35	Something that you can (b) fold and it will look the same on both sides.	(b) Brings left hand up slightly across body G2
30	T	Excellent. So that something when folded will look the same on both sides.	1A (+ve feedback) 2RvC (paraphrase)
31	T	Anyone else want to say anything?	1B (peer)
32	S38	Both sides need to be the same.	(1B)
33	T	Both sides need to be the same, excellent. Are they exactly the same? (a) Like would you draw ... say if you drew a heart on this side (b) with a spike coming out on one ... (c) okay so if I drew a heart and then with a shape over here, (d) do I draw a heart with the same thing coming out the other side?	2RvC (paraphrase) 1A (+ve feedback) 3B (challenge) G2 2RsA (context) G2 2RsA (context) G2 2RsA (context) G2 2RvD (question)

In Utterance 27, S29 begins with the initial idea of “It means the same”. This was not considered to be part of the peer scaffolding as it was simply an answer to the teacher’s question. In Utterance 29, S35 voluntarily extends on this definition by adding, “Something that you can fold and it will look the same on both sides”. Thus, *peer collaboration* (1B) occurred. In this instance, the concept of symmetry has been expanded from being “something the same” to include the classification that one side of something needs to be the same as the other, thus introducing the idea of the “line of symmetry”. In Utterance 32, S38 clarified the second part of S35’s statement by adding that “Both sides need to be the same” (1B), evidencing that students have assumed ownership of the definition. As a consequence, the teacher stepped back from the scaffolding process and ascertained when Level 3 supporting structures could be utilised to further the discourse. This occurred in Utterance 33T, where the teacher applies *making connections* (3B) by challenging the ideas given in the peer collaboration process.

### ***Phases 2 and 3 – Enhance: Explicit Modelling and Guided Application***

In the implementation of VM lessons, there was a considerable change in how the teacher used scaffolding practices in the Enhance phase of the lessons. In the PM lessons, the scaffolding practices followed a more linear format of *explain*, *review* and *restructure* (see Figure 4.2). By contrast, in the VM lessons the scaffolding practices used were more fluid and unstructured, with an adaptive style of implementation, which appeared to be contingent on the needs of students. A major reason for this change was due to the introduction of virtual manipulatives and the iPad, where the applications had their own unique benefits with regard to scaffolding practices. Three observable changes in the Enhance phase of the virtual lesson occurred. These were:

1. a shift in the Level 2 *explaining* scaffolding practices;
2. a more complex implementation of Level 3 scaffolding practices; and
3. an increase in student peer-scaffolding practices.





#### *Shift in the Level 2 explaining scaffolding practices*

The first difference related to how the teacher used *explaining* scaffolding practices. During Phase 2 – Enhance: Explicit Modelling, the iPad acted as the knowledgeable “expert” and used multimodal representations to explain the spatial tasks to students. Thus, in the VM lessons, the teacher’s role changed from explaining the spatial tasks to paraphrasing the iPad’s instructions and modelling the application’s explanation (see Table 4.44).

Presented in Table 4.44 is an example of how a spatial orientation task was explained to students using the iPad application, “Sir Prance-a-lot”. The tasks required students to finish building a 3D model by interpreting a top-down view of the model provided by the computer. They were then directed to create a side view and a front view of the 3D model they had created. Prior to completing these tasks the app “explained” to students what this entailed. As visual representations were a key feature of the iPad’s explanation, screenshots of these visuals are displayed in the last column of the table. In Table 4.44 the “T” in the second column refers to the voice of the iPad. The teacher did not participate in the vignette.

Table 4.44

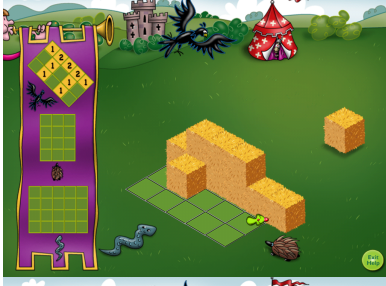
*Shift in the Level 2 Structure of Explain (L3SO VM 9: Utterance 95–98)*

Utterance	Verbal communication	Gesture (non-verbal communication)	Screenshot from iPad
95 I	Peculiar old Prance is very particular about what he leaps. But Sir Plus has forgotten how to use (a) the ancient plans.	(a) A green arrow appears at the bird's eye grid.	
	(b) Help out by using the numbers in the falcon view plan to tell you how many hay bales to place	(b) The arrow runs along the grid highlighting the numbers.	
	(c) here.	(c) Arrow points to section where students are to build the structure.	
	(d) (Game sound)	(d) Automatically moves hay bales into correct position to model how it is done.	
			

Utterance 95I, the voice of the iPad, explains how students were to use the information found in the falcon's view (top-down view) to create a virtual 3D model using hay bales. Through the use of a green arrow, the app indicated (gestured) to students where this graph was situated,

and how to use this graph to calculate how many hay bales were needed. The voice in the app continues the explanation in Utterance 95I(d) by providing a quick demonstration of what this looks like. Utterance 96 (“cool”) and 97 (“wow”) evidenced students’ comments/exclamations. These showed how the iPad app’s multimodal approach to the explanation initiated students’ interest in the activity. Utterance 98I continued with the iPad voicing an explanation of the instructions by demonstrating how to complete (a) the hedgehog’s view graph (side view), and (b) the snake’s view graph (front view). The voice continues by introducing self-correcting/checking functions of the application for students to use to check their work.

As the iPad did not allow for student input (i.e., questions or added insights), the teacher needed to provide scaffolding practices to ensure students understood the task. Thus, the teacher’s scaffolding practices changed from *explaining* (2Ex) (as evidenced in the PM lessons) to *paraphrasing* (2RvC) the multimodal instructions, and demonstrating these instructions, in a *meaningful context* (2RsA). Occasionally, the teacher asked *prompting and probing questions* (2RvD) to clarify students’ understanding. Table 4.45 contains a vignette that followed the iPad’s explanation (i.e., Table 4.44). Utterances 106–109T have been omitted from this transcript as these consisted of the teacher telling students to turn the sound off because it was distracting.

Table 4.45

*Shift in the Level 2 Structure of Explain (L3SO VM 9: Utterance 105–112)*

Utterance	Verbal communication	Gesture (non-verbal communication)	Scaffolding
105 T	(a) We have a horse that wants to jump over (b) this  (c) but he can’t jump until we build it. (d) So this one here shows you the bird’s eye view. That shows you (e) if you are looking straight down on it ..  Okay, so I need to build it like that.	(a) Points to the horse on the top of screen (b) Points to the section where students are to place the hay bales (c) Points back at horse (d) Points to the bird’s eye view (e) Lowers hand (in downward motion) to the top edge of the iPad	G1 2RvC (paraphrase) 2RsA (context) 2RsA (context)  2RsA (context) 2RsA (context)  2Ex  2RsA (context)
110 T	(a) Can you see how down in this corner it says 2?	(a) Points to where it says 2 in bird’s eye view	G1 2RvD (question) 2RsA (context)
111 C	Yes.		
112 T	That means I have to drag 1, whoops, 2. So it’s 2 high. Can everyone see what I’ve done?	Start to drag the hay bales into position	GE 2Ex (T. explain) 2RsA (context)  2RvD (question)

Utterance 105T begins with the teacher *paraphrasing* (2RvC) the iPad’s verbal instructions. The teacher used *pointing gestures* (G1) to create a *meaningful context* (2RsA) for the verbal



instructions given. These *pointing gestures* (G1) were used to guide students’ attention towards certain locations on the iPad. The teacher continued, in Utterance 105T(e), with an *explanation* (2Ex) of what was meant by the iPad’s instruction of the falcon’s view, which entailed students looking down from a top view. Further clarification of this *explanation* (2Ex) was obtained through the teacher’s use of a *meaningful context* (2RsA) scaffold. This scaffold was evidenced through the use of an *iconic gesture* (G2) to create a visual image for the word *down*. Utterance 110T evidenced the teacher’s use of a *prompting and probing question* (2RvD) to check students’ understanding. The teacher continued the *explanation* (2Ex) by modelling the task on the iPad. This modelling was classified as a *meaningful context* (2RsA) scaffold.

*More complex implementation of Level 3 support practices*

The second difference related to the implementation of Level 3 scaffolding practices. Similar to the Orientate phase, the successful use of Level 3 structures occurred in these phases of the virtual lessons. However, there was a change in the frequency of the use of 3B (*making connections*). This was evident in a vignette from Lesson 1, where students used the app “P.O.V.” (see Figure 4.3). The app displayed four different camera views. It required students to select a camera view and from that viewpoint, hide the ball amongst 3D objects. The top panel showed the view from a selected camera position. The bottom panel was the working area, containing the ball and other 3D objects. The app began with one shape and grew in complexity by adding additional shapes as the student progressed.

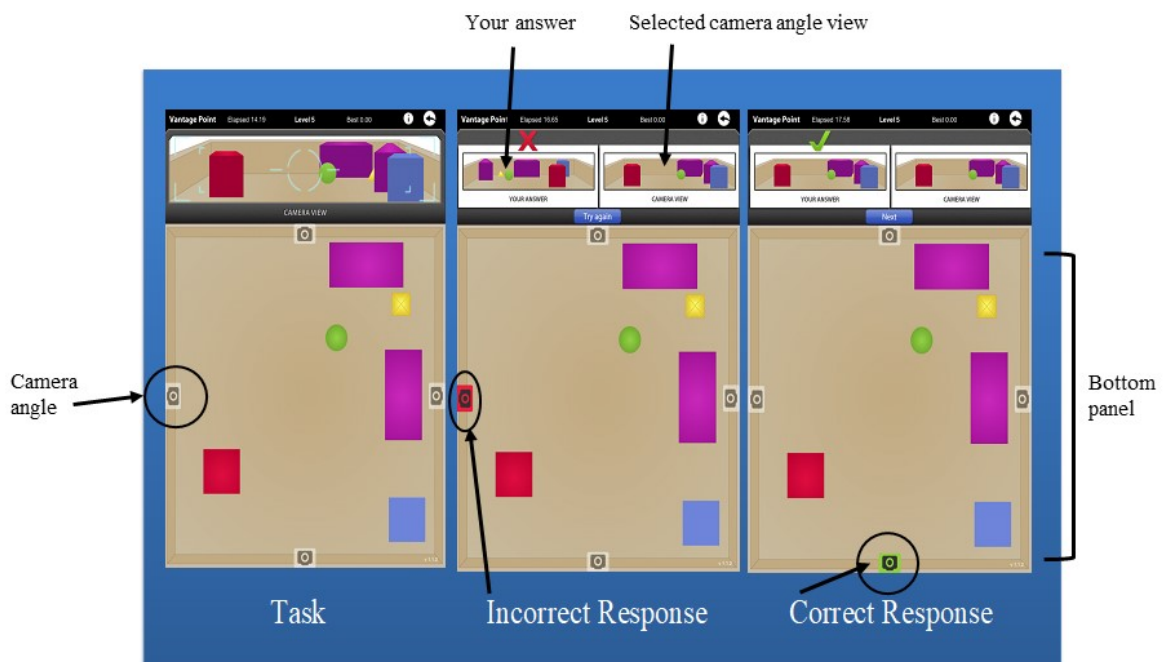

Figure 4.3. Screenshots from the iPad app “P.O.V.”

Presented in Table 4.46 is a vignette where the increased complexity of the Level 3 *making connections* (3B) scaffolding practice was used several times by the teacher.

Table 4.46

*More Complex Implementation of Level 3 Support Structure (LISO VM 1: Utterance 127–136)*

Utterance	Verbal communication	Gesture (non-verbal communication)	Scaffolding
127 T	Put it behind something. (a) <b>But if you change</b> , (b) like for example,  (c) see guys, how I have that there. To hide the ball, I'm using this camera point. (d) I'm looking from this side.  (e) That's what I can see looking from this side. If I hide it, (f) here we go,  (g) I put it behind the purple box.	(a) Beat gesture with closed fist (b) Clicks the left-hand side camera view (c) Points to the left-hand side camera view (d) Moves hand towards the left side of iPad (e) Points to the top panel  (f) Moves the green ball behind the purple box (g) Points to ball	G4 GE G1  G2 G1  GE G1  2RvC (paraphrase) 3B (challenge) 2Ex (T. explain)  2Ex (T. explain) 2RsA (context)  2Ex (T. explain) 2RsA (context)  2Ex (T. explain) 2RsA (context)  2Ex (T. explain) 2RsA (context)  2Ex (T. explain) 2RsA (context)
128 T	Okay. (a) However, if I change camera views and (b) went to one down the bottom, is the ball still hidden?	(a) Holds finger up in the air  (b) Touches bottom camera	G3 GE 3B (linking) 2RsA (context)
129 S41	No.		
130 T	Why?		2RvB (S. explain)
131 T	Why isn't it still hidden? But I hid it.	Holds open palm out	G3 3B (challenge)
132 T	Over here.	Points to where the ball is	G1 2RsA (context)
133 S41	Um, because you changed the camera and it's on the other side.		
134 T	Okay. So when I <b>changed</b> the <b>camera</b> , I'm <b>changing how</b> the <b>angle</b> at which I'm <b>looking</b> at it, or the position from which I'm looking at it.	Raises open palm and beats as says each bold word	G4  3B (linking) 2RsC (rephrase)
135 T	What about if I went to this one over here?	Touches right side camera	GE 2RvD (question)
136 S41	You kinda see it.		

The teacher's increased use of the *making connections* (3B) scaffold was evident in Utterance 127T, 128T, 131T and 134T. The vignette begins with the teacher paraphrasing the student's response to the question ("How did you hide it?") and then *challenging* (3B) this response. In Utterance 128T, the teacher then continued the original challenge by introducing a different camera angle (point of view), with the aim of trying to assist students to realise that

different camera positions (or points of view) provide a different spatial relationship between the ball and the other shapes. After the student responded, the teacher (Utterance 134T) *makes a connection* (3B) for the student by linking their response back to the original 3B scaffolding practice, “but if you change”. During this Utterance 134T, the teacher also introduced the *special language* of “angle” and “position”.

### *Increased student peer scaffolding*

The third difference related to the increased input of students into the scaffolding process. Similar to the Orientate phase, students began to assume responsibility for the learning process. This resulted in the occurrence of peer scaffolding. In these instances, students assumed the role of the “teacher” or “expert” by providing *explaining*, *reviewing* and *restructuring* scaffolds for their fellow classmates. In most instances it was a dominant, “more knowledgeable” learner who led the peer scaffolding. Students were completing a simple reflective symmetry task on the iPad app “Symmetry School”. The task consisted of coloured discs distributed in a pattern on the right side of a line of symmetry. Students were required to drag the correct colour disc into the correct position on the left-hand side of the line of symmetry to make the pattern symmetrical. Figure 4.4 displays a screenshot of this task.

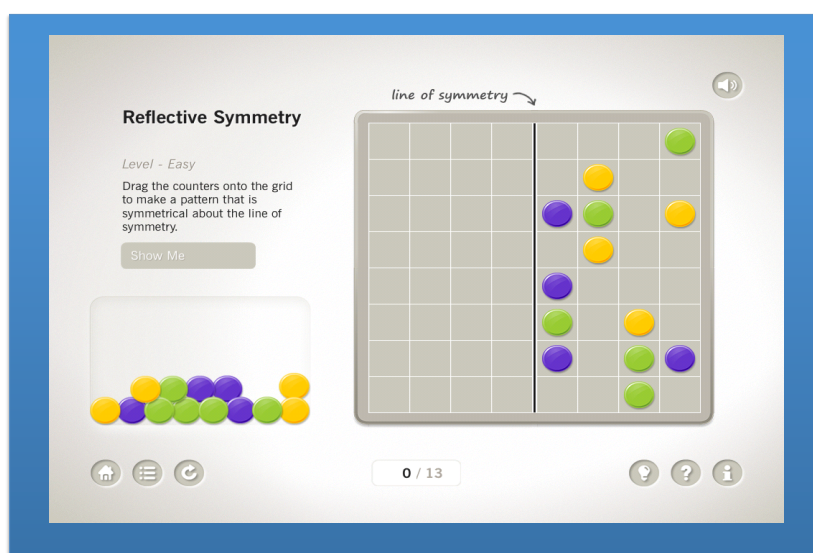

Figure 4.4. Screenshot for the iPad app “Symmetry School”.

Table 4.47 provides an example of students’ increased use of peer scaffolding. The transcript is a vignette from a visualisation lesson on symmetry. Column 6 (Scaffolding) records the particular teacher scaffolding practices students were using with each other as they engaged in the activity.

Table 4.47

*Increased Student Peer Scaffolding (L3SV VM 3: Utterance 145–152)*

Utterance	Verbal communication	Gesture (non-verbal communication)	Scaffolding
145	S37 Drag one of those over to there.	Drags a yellow disc into the correct position	GE 2Ex (T. explain)
146	S42 (a) Like this .....	(a) Drags three more yellow discs into the correct position	GE
	(b) .....	(b) Starts to drag a green disc	GE
147	S37 There	Pointing to where the green disc should go	G1 2Ex (T. explain)
148	S42 .....	Drags the green disc into correct position	GE
149	S37	Takes over the task dragging blue discs into position	GE 2Ex (T. explain) 2RsA (context)
150	S42 You have to make a copy.	Points to the screen	G1 3B (linking)
151	S37 (a) .....	(a) Continues with 3 other green and blue discs	GE
	(b) That one there .....	(b) Points to a blank space	G1
	(c) Is it that one or that one?	(c) Points to two different coloured discs	G1 2RvD (question)
152	S42 Yeah, that one.	Points to the correct colour disc	G1

In this transcript S37 has taken on the dominant role of the scaffolder. In Utterance 145, S37 is *telling the answer* (2Ex) to S42. S37 continues this scaffolding role in Utterances 147 and 149. However, in Utterance 149, the *explanation* (2Ex) entailed non-verbal communication. S37 modelled the task for S42. In Utterance 150, S42 has registered understanding of the concept by *explaining* (2Ex) that, “You have to make a copy”. This statement also entailed *making a connection* (3B) as S42 was linking S37’s actions to the concept of symmetry. S37 continued to assume the “teacher-like” role by asking a *prompting and probing question* (2RvD) in Utterance 151. By doing this, S37 checked S42’s understanding of the concept. S37’s actions seemed to be contingent on S42’s understanding of the concept. She first used *explaining* (2Ex), when S42 did not understand what the task required him to do, and then used a *prompting and probing question* (2RvD) after S42 exhibited that he had begun to understand the concept of symmetry (see Utterance 150).

On some occasions, students were even implementing their own Level 3 support structures by challenging the teacher’s explanation. Table 4.48 provides an example of this in the vignette taken from the same visualisation lesson. The teacher had just explained to students that the task required students to create the mirror image of the given pattern.

Table 4.48

*Students Challenging Teacher's Explanation (L3SV VM 6: Utterance 87–90)*

Utterance	Verbal communication	Gesture (non-verbal communication)	Scaffolding
87	S51	Does it have to be the same colour?	3B (challenge)
88	T	Well would it be symmetrical if it was a different colour?	3B (challenge)
89	S51	(shakes head)	
90	T	No, because remember it has to be the same on both sides just opposite.	2RvC (paraphrase) 2Ex (T. explain)

In Utterance 87, the student starts the discourse by asking a question to *challenge an idea* (3B) that they have formed about the task. The student had formed this question from watching the actions of the teacher when modelling the task on the iPad. In this situation, the student has actually commenced to self-scaffold. By asking the teacher a question, the student is thinking and evaluating the course of action he would take to complete the task. This resulted in the teacher guiding the student to *make connections* (3B) through the use of a question to challenge their thinking (Utterance 88T). In Utterance 89, the student responded to the teacher's challenging question with a shake of his head to indicate 'no'. The teacher *paraphrases* (2RvC) the student's response and continues scaffolding by adding an *explanation* (2Ex) of why this has to occur.

#### ***Phase 4 – Synthesise***

When comparing the PM and VM lessons in the Synthesise phase, both contained similar types of mathematical dialogue, which were guided through the use of Level 2 and Level 3 scaffolding structures. However, the use of Level 3 scaffolding practices in the VM classes resulted in changes to who was leading the dialogue (i.e., a change to the teacher–learner agreement). In the PM class, the dialogue was predominantly “teacher talk” (i.e., the teacher had to continually offer support to continue the discourse). By contrast, students in the VM class displayed increased levels of participation in mathematical dialogue without the need for consistent *prompting and probing* (2RvD) from the teacher. In addition, within the VM lessons there was a reduction in the use of Level 3 scaffolding practices compared to the Orientate and Enhance phases. The Level 3 structure where this reduction predominantly occurred was the use of the *making connections* (3B) scaffold. As the VM students appeared to be leading more instances of mathematical dialogue, the teacher's role mainly consisted of *paraphrasing* (2RvC) students' responses and providing students with *positive feedback* (1A) to acknowledge their contributions to these discussions.

While there was minimal change to the structures of the Synthesise phase in the VM lessons as compared with the PM lessons, there were some changes in the emphasis of how these structures were used. The three differences observed in this phase included:

1. increased instances of the teacher *explaining* (2Ex) scaffold by adding further detail to students' responses;
2. students' acknowledgement of the self-correct function embedded within the apps; and
3. students' acknowledgement of the importance of peer scaffolding.

#### *Increased instances of teacher explaining (2Ex)*

As a consequence of students leading the mathematical dialogue in the Enhance phase of the lessons, the teacher increased her input into the Synthesise phase by adding extended explanations of students' responses. The teacher used this process to clarify whole class understanding of students' responses. The vignette used to exhibit this is from Lesson 1 (L1SO), where students were using the app "P.O.V.". Students were required to complete two tasks on this app. Presented in Figure 4.5 are screenshots of these two tasks. The top three photos show examples of the first task, while the bottom three show examples of the second task. In the first task, the small rectangular screen displays a visual representation of a variety of 3D objects from a particular camera angle. The larger bottom screen contains an aerial view (top-down view) of the same 3D objects. There are four cameras located around the edges of this box to represent the different points of view. The first task required students to tap on the camera (on the bottom screen) that represents the correct point of view for the image generated in the top screen. In other words, students were to decide from which camera angle the top box picture was generated. The second screenshot presents an incorrect choice. The incorrect camera choice is coloured red in the bottom part of the screen. The top screen then provides "direct real-time feedback" by displaying to students the view of the objects from the camera angle they chose. This is indicated as incorrect with a red "x" marked above the visual. To the right of this visual is the view students are trying to represent. The third screenshot illustrates the images created when a correct choice was made. In the second task, there is only one camera. Students were asked to move the 3D objects (in the bottom screen) into the correct position to match the view of the objects found in the camera view (in the top screen). The app again provided direct real-time feedback as shown in the second and third screenshot of task two. Students were also provided with an extra "sneak peek" screen to self-correct while they were moving the objects around (see small upper screen in first screenshot of task two).

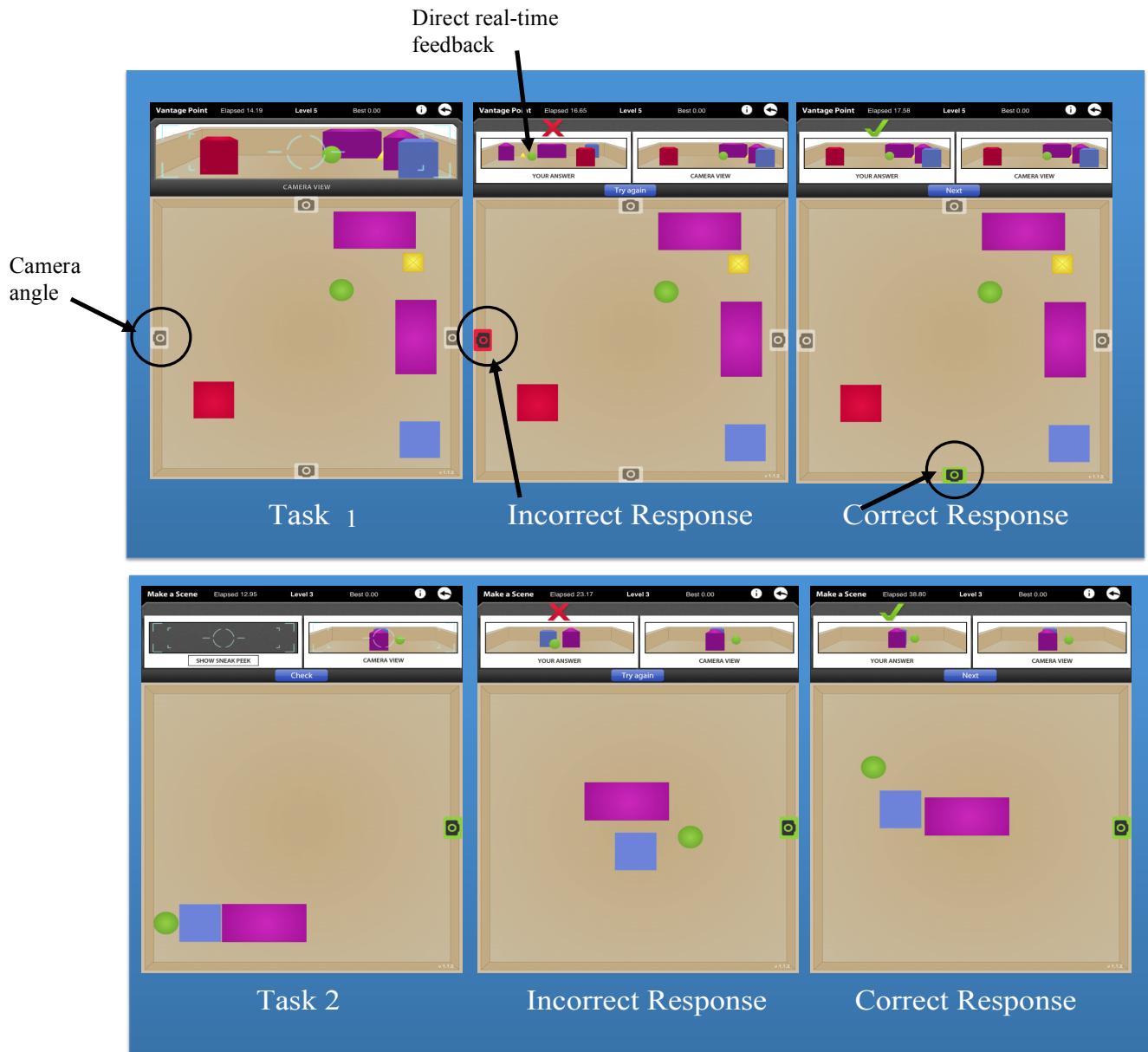

Figure 4.5. Screenshot of tasks required of students in the app “P.O.V.”

Table 4.49 shows how the teacher firstly *paraphrased* (2RvC) student responses; then *asked the students to explain* (2RvB) their response; provided clarification of the students’ response by providing an *explanation* (2Ex); and finally added more detail to further *explain* (2Ex) the concept.

Table 4.49

Teacher Explain (2Ex) with Changed Paraphrasing (2RvC) Structure (LISO VM 1: Utterance 182–187)

Utterance	Verbal communication	Gesture (non-verbal communication)	Scaffolding
182 T	So, you looked at the (a) top view that you can see, and  (b) then you looked at the camera view. But how did you know (c) which position it was going to be, whether it was from the (d) top,  (e) bottom, or  (f) the side cameras?	(a) Hand positions like holding an imaginary iPad  (b) Points in the air to an imaginary spot  (c) Points randomly to different positions  (d) Places index finger high in the air to indicate “top”  (e) Moves finger down to show “bottom”  (f) Moves finger to the “side”	2RvC (paraphrase) G3  G1  2RvB (S. explain) G1 G2 2RsA (context) G2 2RsA (context) G2 2RsA (context)
183 S33	Uh, sometimes the view .... There was something in the way of it.		
184 T	Okay. (a) So, you used, (b) when something was in (c) front of something else,  (d) you used <b>that information</b> to help you tell you <b>where it was</b> ?	(a) Points to student  (b) Flat hand in front of body  (c) Other hand moved in front of flat hand  (d) Repeated gestures (b) and (c)	1A (+ve feedback) G1 2Ex (T. explain) G2 2RsA (context) G2 G4
185 T	Okay. <b>Does everybody understand what he means?</b>	Beats previous actions on bold words	G4 2RvD (question)
186 EC	Yes.		
187 T	So if there was (a) a cube in front of  (b) a sphere, he would then go, oh, I got to look for  (c) which camera has the cube closest to it. Good work.	(a) Places right hand like holding an imaginary cube  (b) Places left hand in front of right hand like grasping imaginary sphere  (c) Indicates front camera angle by moving front hand forward	2Ex (T. explain) G2 2RsA (context)  G2 2RsA (context)  G2 1A (+ve feedback)

Utterance 182T begins with the teacher *paraphrasing* (2RvC) the student’s response. After the teacher had *paraphrased* (2RvC) the student’s response, the teacher *asked the student to explain* (2RvB) how they knew which camera to use. This scaffold was used to get further information from the student about their thinking process. As the student’s response in Utterance 183S33 did not completely explain her thinking, the teacher (Utterance 184) *explained* (2Ex) an appropriate response. She also added a *meaningful context* (2RsA) for the response by iconically gesturing the word “front” to assist understanding. The teacher then clarified the concept for students by continuing the *explanation* (2Ex) in Utterance 187. A *meaningful context* (2RsA) scaffold accompanied this explanation. Iconic gestures were used to provide a symbolic representation of the 3D objects mentioned in the explanation.



### *Student acknowledgement of self-correct function embedded in the apps*

The second difference related to students' understanding of what assisted their learning of spatial concepts. During the mathematical discourse found in the Synthesise phase, a common response from students involved the acknowledgement of the self-correct function that was found in most of the iPad apps. The use of this function allowed students to modify their own misconceptions without the use of teacher scaffolding. Due to this, students were able to take on some of the responsibility of providing their own scaffolding. The following vignette was taken from a visualisation lesson. This lesson required students to mentally fold and unfold the nets of 3D objects. In the app "3D Objects and Nets", students were given three different tasks. Figure 4.6 displays screenshots from this app.

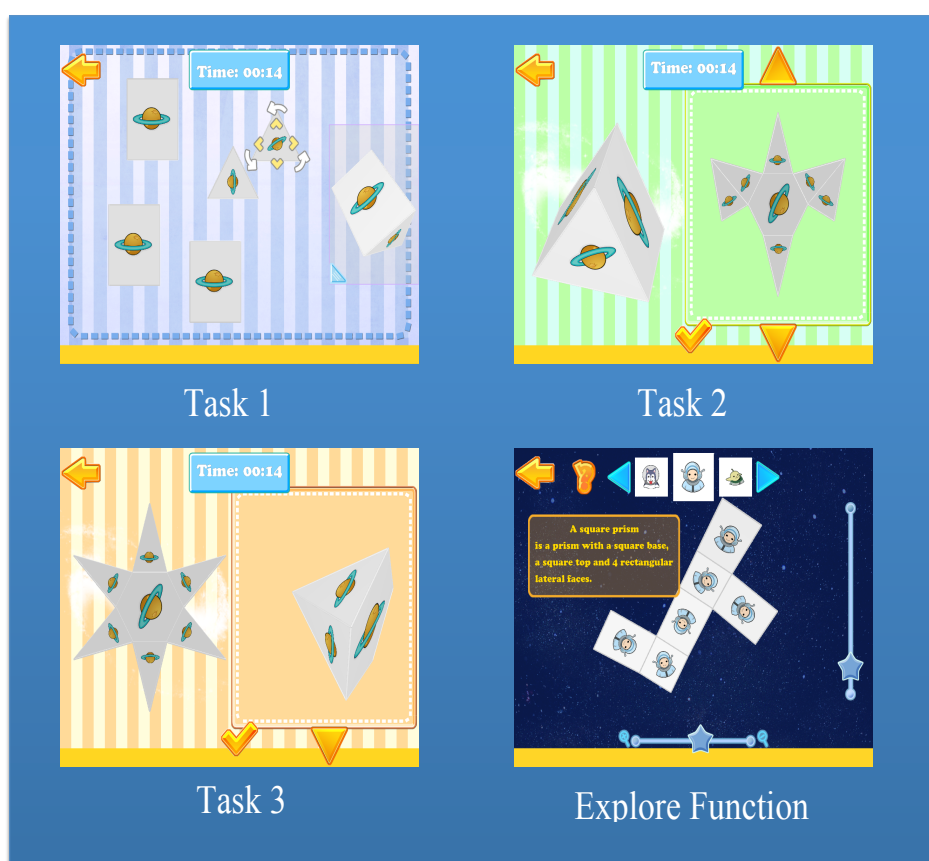

Figure 4.6. Examples of the three tasks and the "explore" function in the app "3D Objects and Nets".

Task 1 required students to rotate the given 2D shapes to form the correct net for the given 3D shape. Task 2 required students to select the correct net that could be folded into the given 3D shape. Task 3 required students to select the 3D shape that could be made from the given net. In all of these tasks, students had the availability of using the "explore" section in the app. This explore section allowed students to select a 3D shape and then unfold it into a net. As seen in the following vignette, students tended to use this function to check if their response was

correct. Table 4.50 provides a vignette of where students are acknowledging the helpfulness of this explore function within the app.

Table 4.50

*Student Acknowledgement of the iPad's Self-Correct Function (L2SV VM 6: Utterance 7–15)*

Utterance	Verbal communication	Gesture (non-verbal communication)	Scaffolding
7	S34	You could check if it was right or wrong ...	
8	T	You could check if it was right or wrong. Excellent. So it told you if you were right or wrong. Well done. Anyone else?	(out of camera range) 2RvC (paraphrase) 1A (+ve feedback) 2RvC (paraphrase) 1A (+ve feedback) 1B (peer)
9	S50	It helped me because if you got the math wrong, you could've took the ... you could've took the .... what's um the ... not the flat one ...	
10	T	The 3D shape?	2Ex (T. explain)
11	S50	Yeah. ... Then you could see what it looked like.	
12	T	Excellent.	1A (+ve feedback)
13	T	Okay. So, if you, if you get it wrong, you then have the option to open up the 3D shape to make the net for you, to help you?	(out of camera range) 2RvC (paraphrase)
14	S50	Yeah.	
15	T	To see where you went wrong.	2Ex (T. explain)

In Utterance 7, S34 acknowledges the explore function of the iPad by stating that students “could check if it was right or wrong”. This was an example of the direct real-time feedback feature that was embedded within the iPad apps. The teacher responded by *paraphrasing* (2RvC) the student’s response and adding *positive feedback* (1A) for their contribution. The teacher then suggests other students *collaborate* (1B) by providing more responses. In Utterance 9, S50 further explains the assistance of the explore function by describing how it helped him. This is finished in Utterance 11. In Utterance 13, the teacher *paraphrased* (2RvC) the student’s response to ensure that the whole class understood what S50 was referring to, and then added further explanation (2Ex) in Utterance 15.

#### *Student acknowledgement of peer scaffolding*

During the Synthesise phase, students shared how the peer scaffolding from the Orientate and Enhance phases had assisted their formation of spatial concepts. When students talked about various aspects of the iPad (e.g., the representations presented in the apps; the self-correct function; and the ability to easily manipulate objects) they always acknowledged that it was the interactions with their partner that contributed to their understanding. Some of the scaffolding

supports these peers used included direct telling; clarification of the task; providing prompts; reference to a partner being more knowledgeable about the concept; and modelling the task. Table 4.51 provides an example of some of this discourse regarding the assistance provided by peers. The lesson used the app “Sir Prance-a-lot”, which involved creating models from different points of view (e.g., top down, front and side).

Table 4.51

*Student Acknowledgement of Peer Scaffolding (L3SO VM 5: Utterance 200–213)*

Utterance	Verbal communication	Gesture (non-verbal communication)	Scaffolding
200 S37	Having your partner.		
201 T	You found having (a) your partner helped you more than just working ... So if you had to work on (b) the app by yourself, do you think you'd be learning as much or (c) you learn more with your partner?	(a) Hands out beside body (questioning)  (b) Points to imaginary iPad  (c) Points further away to the side of body to imaginary partner	G3  G1  G1  2RvC (paraphrase)  2RvD (question)
202 S37	With your partner.		
203 T	Why? Why did you learn more with your partner? Why do you think you learned more with your partner?		2RvB (S. explain) 2RvB (S. explain) 2RvB (S. explain)
204 S37	'Cause they give you ideas of what you should do		
205 T	They give you ideas and help you along.		2RvC (paraphrase)

The vignette begins, in Utterance 200, with a student acknowledging the assistance given by their peers. The teacher *paraphrased* (2RvC) this response and then asked the student a *probing question* (2RvD) to ascertain which had better assisted their learning, the app or the peer assistance. When the student responded “with your partner”, the teacher *asked the student to explain* (2RvB) her answer. S37’s response indicated that it was the direct telling or the prompting from a peer that had assisted her learning. She indicated this in Utterance 204 by stating that peers “give you ideas”. The teacher then *paraphrased* (2RvC) this response to confirm understanding. This idea, that a peer was acting as a more knowledgeable learner or an “expert” on the topic, was the most commonly suggested reason why peers were more helpful than the iPad. This suggests that students valued the assistance given by their peers.

### ***Summary of virtual lessons***

The most notable difference between the PM lessons and the VM lessons was students’ participation in mathematical discourse. As a result of these increased discussions, the teacher

was able to introduce Level 3 structures much earlier into the teaching phases. Students were also given more opportunity to take responsibility for their learning. This was evident in the peer scaffolding that occurred to support students' learning of spatial concepts. Both of these changes were evident throughout all the phases of the virtual lessons. Figure 4.7 provides a visual summary of the teacher's implementation of scaffolds according to the phases of the lesson.

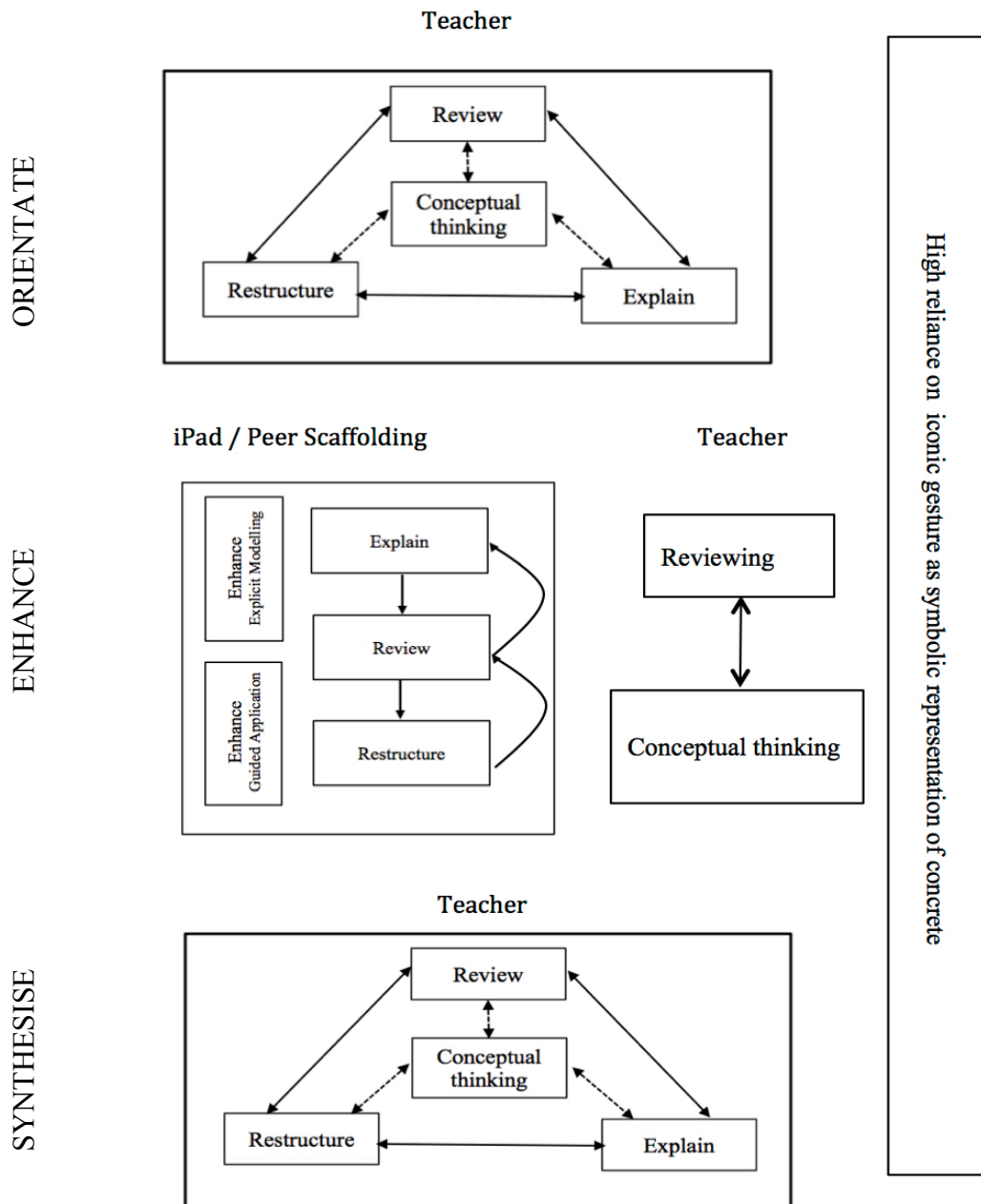

Figure 4.7. Model of main teacher scaffolding levels implemented in each lesson phase.

In the VM class, the Orientate phase consisted of a review process that was more dynamic than the PM class. This was a result of students' increased engagement and willingness to participate in mathematical discourse. During this phase, the teacher utilised all Level 2 scaffolds (i.e., explaining, reviewing and restructuring), as well as Level 3 scaffolds. With more

mathematical discourse, the teacher implemented Level 2 restructuring scaffolds of *rephrasing* (2RsC) and *negotiating meanings* (2RsD) to ensure a shared meaning of special keywords. As Level 2 restructuring scaffolds were implemented, the teacher was required to also use the Level 2 scaffold of explaining. As a fluid use of all Level 2 scaffolds occurred in the Orientate phase, the teacher then had the opportunity to implement Level 3 scaffolds.

The Enhance phase changed from a more linear procedure that occurred in the PM class, to a more interactive and ever-evolving process in the VM class. While the Enhance: Explicit Modelling phase was similar in nature to the *explain* section of the PM class; the VM class differed in the emphasis of the “expert” role. In the VM class, the iPad acted as the *explainer* and the teacher used *reviewing* scaffolds to support this explanation process. It seemed that this change in the teacher–learner agreement (in particular, who was leading the discourse) was a contributing factor to the emergence of peer scaffolding during the Enhance: Guided Application phase. As students were peer scaffolding (see Table 4.47) in the Enhance: Guided Application phase, the teacher was able to focus on scaffolding the development of students’ conceptual thinking through the implementation of Level 3 scaffolds. Level 2 scaffolds were still occurring in this phase; however, students were beginning to initiate these during the act of peer scaffolding. As many of the iPad applications had a self-correcting function, most of the students’ misconceptions were also being dealt with during this peer scaffolding.

Finally, the Synthesise phase returned to a similar procedure found in the Orientate phase. However, as most of the students’ misconceptions had been addressed in earlier phases of the lesson, the use of restructuring scaffolds decreased in this phase. In the VM class, students directed this phase. Thus, the role of the teacher changed. Due to this decreased emphasis on the role of the teacher, the teacher, feeling the need to “teach”, often added extra explanations.

### **4.3.3 Comparison of teacher scaffolding practices in the PM and VM lessons**

In order to analytically compare the communication of students’ learning in the PM and VM classes, transcripts from the same lesson within each sequence were selected. Lesson 3 from the teaching experiment was used as it represented students’ learning at the end of the lesson sequence pertaining to the spatial concept of “orientation”. The lesson consisted of students examining 3D models from different orientations and using language to describe these “points of view”. Appendix F provides a full comparison of the lesson structure for the PM and the VM class. The videos from each class (PM and VM) were analysed using the categories delineated in section 5.2. A brief overview of the PM lesson is presented in Table 4.52.

Table 4.52

*Brief Overview of Lesson 3 of Spatial Orientation in the PM Class*

Phase	Brief description
Orientate	Re-examined use of positional language to describe objects in different orientations.
Enhance: Explicit Modelling	Teacher modelled that when the 3D Lego brick model is viewed from different points of view the locations of the different coloured bricks change.
Enhance: Guided Application	Students worked in pairs to create 3D models and describe what they look like from different locations (e.g., above, front).
Synthesise	Teacher led discussion about what students were learning.

Briefly, Lesson 3 in the VM class entailed the use of the app “Sir Prance-a-lot”. The app required students to create a 3D representation, using hay bales, from a bird’s top-down view model. Once students had created the model, a front-view and side-view representation of the model needed to be completed (see Appendix F). A brief overview of this lesson is presented in Table 4.53.

Table 4.53

*Brief Overview of Lesson 3 of Spatial Orientation in the VM Class*

Phase	Brief description
Orientate	Re-examined use of positional language to describe objects in different orientations.
Enhance: Explicit Modelling	The iPad acted as a scaffolding agent and presented multimedia representations to instruct students about the task. Teacher paraphrased iPad instructions.
Enhance: Guided Application	The iPad required students to “see” objects from different viewpoints. They worked with their peers to complete the task.
Synthesise	Teacher led discussion about what students were learning.

First, for both classes, videos of Lesson 3 were coded in terms of the scaffolding practices the teacher used in each of the four lesson phases. Second, the total frequencies for each scaffolding level (Level 1, 2 and 3) were analysed. Third, the total frequencies of these scaffolding practices were split into the four lesson phases. Finally, the frequencies of each scaffolding practice were analysed according to the four lesson phases.

Pearson’s chi-squared test was used to analyse the differences between the frequencies of datasets. In order to compare the two datasets where the sample sizes are not the same, Pearson’s chi-squared test weights the data and compares sample proportions. Thus, it reports on “trends”, with significance indicating the trends in the sample proportions are different, and non-significance indicating the trends in the sample proportions are the same. If a value in the data is zero, then the assumption underpinning Pearson’s chi-squared is violated, and therefore

it cannot be used. Additionally, if a value in the data is less than 5, then Fisher's exact test (a more rigorous test) is used (Field, 2009).

Presented in Figure 4.8 is the total frequency of use of Level 1, Level 2 and Level 3 scaffolds for the two classes for Lesson 3.

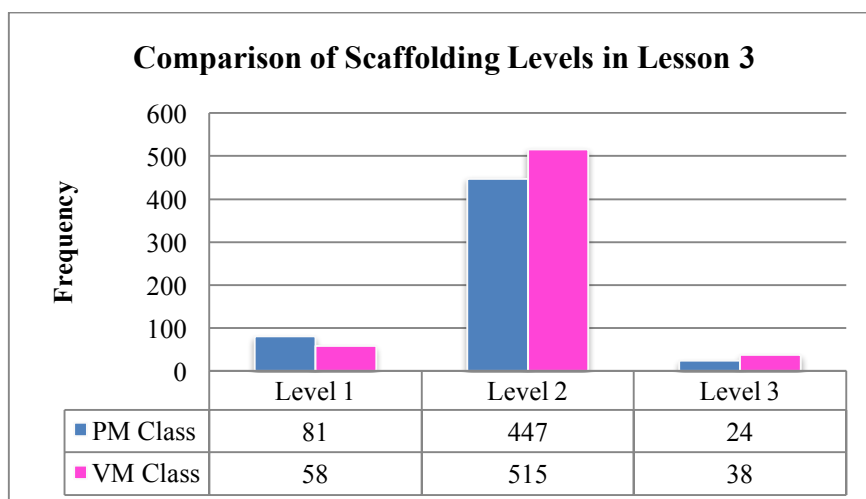

Figure 4.8. Comparison of totals of each scaffolding level (PM vs. VM).

As the data were categorical, Pearson's chi-squared was used to analyse the significance of the differences between the trends of use of each scaffolding level (i.e., Level 1, Level 2 and Level 3). The results of this analysis revealed that there was a statistically significant difference between the frequencies of use of each scaffolding level in each class ( $X^2(2) = 8.803, p = .012$ ). More Level 1 practices occurred in the PM class as compared to the VM class (PM:VM = 82:58), and more Level 2 and Level 3 scaffolding practices occurred in the VM class as compared to the PM class (Level 2 PM:VM = 447:515; Level 3 PM:VM = 24:38).

Further exploration involved analysis of the scaffolding practices according to the teaching phases of the lesson (i.e., Orientate, Enhance: Explicit Modelling, Enhance: Guided Application, and Synthesise). Presented in Table 4.54 are the frequencies of levels of scaffolding for each phase of the lesson.

Table 4.54

*Frequencies of Occurrence for Each Level of Scaffolding for Each Phase of the Lesson*

Phase	Level 1		Level 2		Level 3	
	PM	VM	PM	VM	PM	VM
Orientate	5	7	31	40	0	4
Enhance: Explicit Modelling	12	10	113	195	5	10
Enhance: Guided Application	39	30	160	217	4	16
Synthesise	25	9	143	68	15	8

Pearson’s chi-squared tests were used for the three phases (Enhance: Explicit Modelling, Enhance: Guided Application, and Synthesise), thus ensuring all assumptions have been met. The results revealed a statistically significant difference between the trends of the scaffolding practices used in the PM and VM class **only** for the Enhance: Guided Application phase ( $X^2(2) = 8.443, p = 0.015$ ), and these differences predominantly occurred in Level 2 and Level 3 scaffolding practices (see Table 4.54), where there was a significant increase in the frequency of use in the VM class. It should also be noted that in the Synthesise phase more Level 2 and Level 3 scaffolding occurred in the PM class as compared to the VM class (see Table 4.54), indicating that these higher levels of scaffolding were occurring earlier in the VM class as compared to the PM class.

To further explore the nature of the differences between the PM and VM classes, a comparison of each scaffolding practice used in the Enhance: Guided Application phase of the lesson was made. Presented in Figure 4.9 is a graph of the frequencies of each scaffolding practice observed in the PM and VM classes during the Enhance: Guided Application phase.

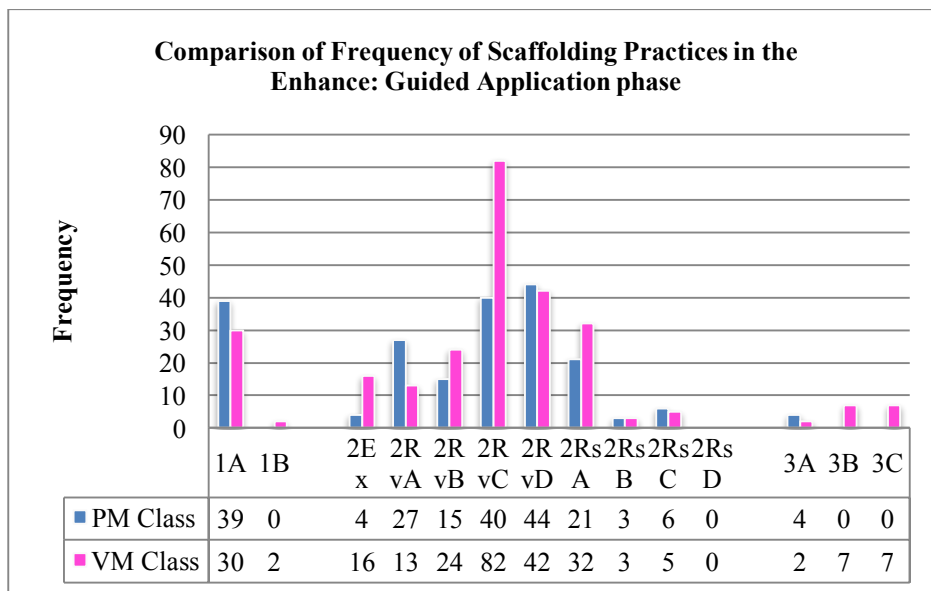

Figure 4.9. Comparison of frequencies of each scaffolding practice in the PM and VM classes in the Enhance: Guided Application phase.

Pearson’s chi-squared could not be used to analyse the differences in the data as the assumptions underpinning its use were violated.

Examination of this graph revealed several major differences between the classes on particular scaffolding practices. For the VM class, there was significantly more frequent use of:

1. Level 2Ex: *teacher explain* (PM:VM = 4:16);
2. Level 2RvC: *paraphrasing* (PM:VM = 40:82); and



3. Level 3 scaffolds
  - (a) 3B: *making connections* (PM:VM = 0:7)
  - (b) 3C: *generating mathematical discourse* (PM:VM = 0:7).

For the PM class, there was significantly more frequent use of:

1. Level 2RvA: *look, show or verbalise* (PM:VM = 27:13).

This appears to be related to the physicality of the manipulatives used.

Presented in Figure 4.10 is a summary of the findings when comparing the scaffolding practices for the two classes (i.e., PM and VM).

<b>Summary of findings when comparing scaffolding practices for the two classes</b>
<b>Overall:</b> There was a significant difference between the scaffolding practices used in each class. More Level 2 and Level 3 scaffolds were used in the VM class and more Level 1 scaffolds were used in the PM class.
<b>Phases:</b> There was a significant difference between the scaffolding practices used only for the Enhance: Guided Application phase.
<b>Enhance: Guided Application phase</b> <b>VM class:</b> Increased use of (a) Level 2Ex <i>teacher explain</i> ; (b) Level 2RvC <i>paraphrasing</i> ; (c) Level 3B <i>making connections</i> ; and (d) Level 3C <i>generating mathematical discourse</i> . <b>PM class:</b> Increased use of Level 2RvA <i>look, show or verbalise</i> .

Figure 4.10. Summary of findings when comparing scaffolding practices for the two classes.

To further compare the teaching differences that occurred between the PM and VM classes, the teacher's use of mathematical words and visual mediators was analysed. The results of this analysis are presented in the next section.

#### 4.3.4 Comparison of teacher's mathematical words and visual mediators

First, investigation of the teacher's *mathematical words* occurred by examining the different *keywords* used and their frequency of use. While investigation of students' *mathematical words* included examining changes in sentence structure (see section 5.2.1), the teacher generally used more complex forms of sentence structure throughout the entire lesson, making examination of this dimension difficult. Second, the teacher's *visual mediators* were analysed through her use of gestures.

#### 4.3.4.1 Comparison of mathematical words

Presented in Table 4.55 is the number of different *special keywords* used in each phase of the lesson (different *special keywords* could include line, face, edge, top, bottom, etc.). The number in the brackets shows how often these *special keywords* were used during the phase. For example, in the Orientate phase of the PM lesson, 8 different *special keywords* were used, and the use of these words occurred 14 times during this phase, hence 8(14). A full account of which *special keywords* were used and the frequency of use is presented in Appendix R.

Table 4.55

*Number of Different Special Keywords (and Frequency of Use) Used by the Teacher in the Four Phases of Lesson 3 in the PM and VM Classes*

Phase	No. of different special keywords (frequency of use)	
	PM class	VM class
Orientate	8 (14)	18 (34)
Enhance: Explicit Modelling	9 (28)	29 (141)
Enhance: Guided Application	17 (87)	37 (113)
Synthesise	9 (21)	24 (77)

Results from analysis using a Pearson's chi-squared test to compare the number of different keywords in the PM and VM classes indicated that there was no statistically significant difference between the proportion of different *special keywords* used in the PM and VM classes ( $X^2(3) = .758, p = 0.861$ ). However, a comparison of the number of different *special keywords* used presented in Table 4.55 clearly shows that a greater range of *special keywords* was used in the VM class in all phases of the lesson (e.g., Enhance: Explicit Modelling PM:VM = 9:29; Synthesise PM:VM = 9:24).

Additionally, results from the Pearson's chi-squared analysis on the frequency of *special keywords* used by the teacher indicated that there was a statistically significant difference between the PM and VM class ( $X^2(3) = 35.74, p < .01$ ). As presented in Table 4.55, although the frequency of *special keywords* used by the teacher in the VM class was higher than the frequency in the PM class in every phase (i.e., Orientate PM:VM = 14:34; Enhance: Explicit Modelling PM:VM = 28:141; Enhance: Guided Application PM:VM = 87:113; and Synthesise PM:VM = 21:77), the frequency in the Enhance: Explicit Modelling phase of the VM class was a fivefold increase (i.e., PM:VM = 28:141). Therefore, it is suggested that the VM students were not only exposed to a greater variety of *special keywords* during Lesson 3, but were provided with substantially more frequent use of them in an earlier phase of the lesson (Enhance: Explicit Modelling). It is suggested that the earlier introduction of *special keywords*

provided the VM students with earlier opportunities to extend their own use of *mathematical words*. This inference is further explored in the analysis of students' data and VM students' increased usage of *special keywords* in Chapter 5 (see Table 5.12, section 5.3.1).

#### 4.3.4.2 Comparison of visual mediators

The second characteristic that influenced the mathematical discourse of the teacher was *visual mediators* (gestures). The analysis of the teacher's use of gestures began with examining the overall frequency of each gesture used by the teacher in Lesson 3. These frequencies are presented in Figure 4.11.

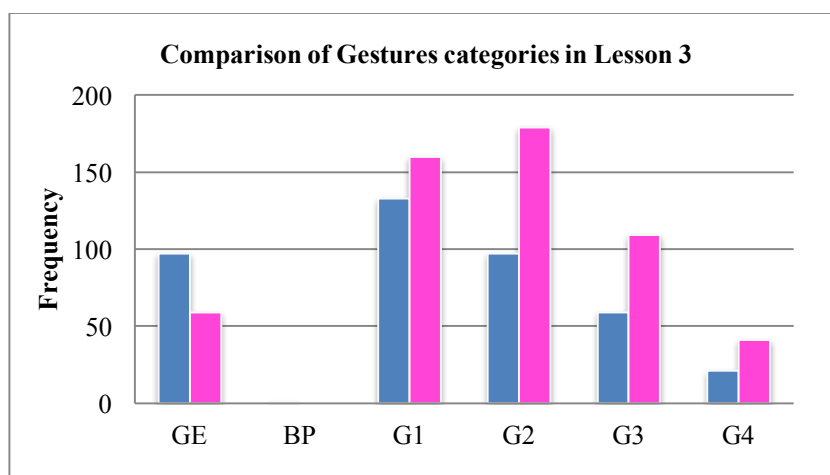

Figure 4.11. Comparison of overall frequencies of each gesture category in the PM and VM classes in Lesson 3.

Overall, the frequency of gestures used in the VM class was higher than in the PM class (with the exception of GE). Results from a Pearson's chi-squared test indicated that there was a statistically significant difference between the trend of use of gestures for the PM and VM classes ( $\chi^2(4) = 37.438, p = < .01$ ). Table 4.56 presents the frequencies and percentage frequency of the different gestures (with the exception of BP) used by the teacher in the PM and VM classes.

Table 4.56

*Frequency and Percentage Frequency of Different Gestures Used by the Teacher in Lesson 3 in the PM and VM Classes*

Gesture category	Frequency		Percentage frequency	
	PM	VM	PM	VM
GE (grounding)	97	59	24	11
G1 (pointing)	133	160	33	29
G2 (iconic)	97	179	24	33
G3 (metaphoric)	59	109	14	20
G4 (beat)	21	41	5	7
TOTAL	407	548	100	100

The frequencies presented in Table 4.56 indicate that the teacher used more:

1. GE (grounding) gestures in the PM class, where the percentage frequency as a proportion of all gestures used in that class was more than double the proportion of such gestures used in the VM class (i.e., PM:VM = 24%:11%); and
2. G1 (pointing), G2 (iconic), G3 (metaphoric), and G4 (beat) gestures in the VM class, with the biggest proportional difference evident in G2 (iconic) gestures (i.e., PM:VM = 24%:33%).

To further scrutinise these trends, GE and G2 gesture frequencies for each phase of Lesson 3 were analysed. Presented in Figure 4.12 is a comparison of the GE (grounding) gestures in the PM and VM classes.

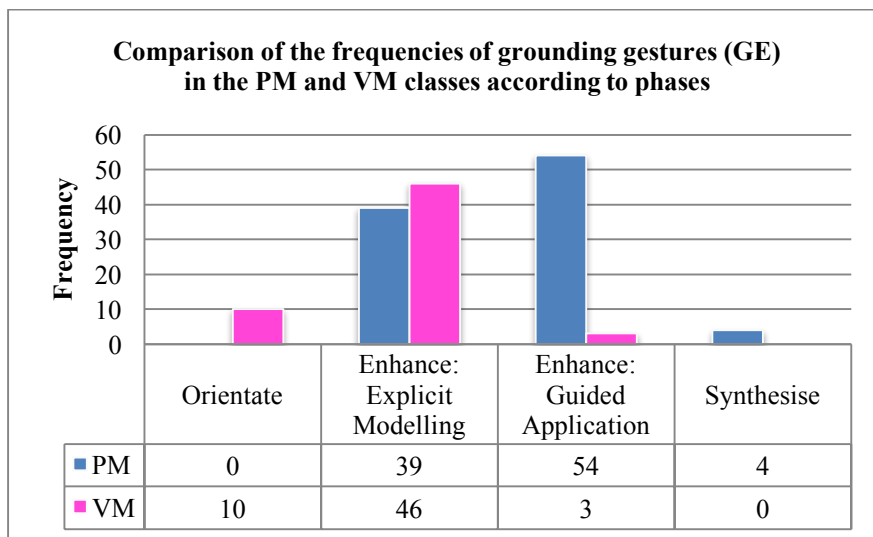

Figure 4.12. Comparison of the frequencies of grounding gestures (GE) in the PM and VM classes according to phases.

Pearson's chi-squared could not be used to analyse the frequencies of grounding gestures (GE). However, Figure 4.12 shows that there was a greater use of grounding gestures (GE):

1. in the Orientate and Enhance: Explicit Modelling phases in the VM class (i.e., Orientate PM:VM = 0:10; Enhance: Explicit Modelling PM:VM = 39:46); and
2. in the Enhance: Guided Application and Synthesise phases in the PM class (i.e., Enhance: Guided Application PM:VM = 54:3; and Synthesise PM:VM = 4:0).

Presented in Figure 4.13 is the comparison of the G2 (iconic) gestures in the PM and VM classes according to the phases of the lesson.

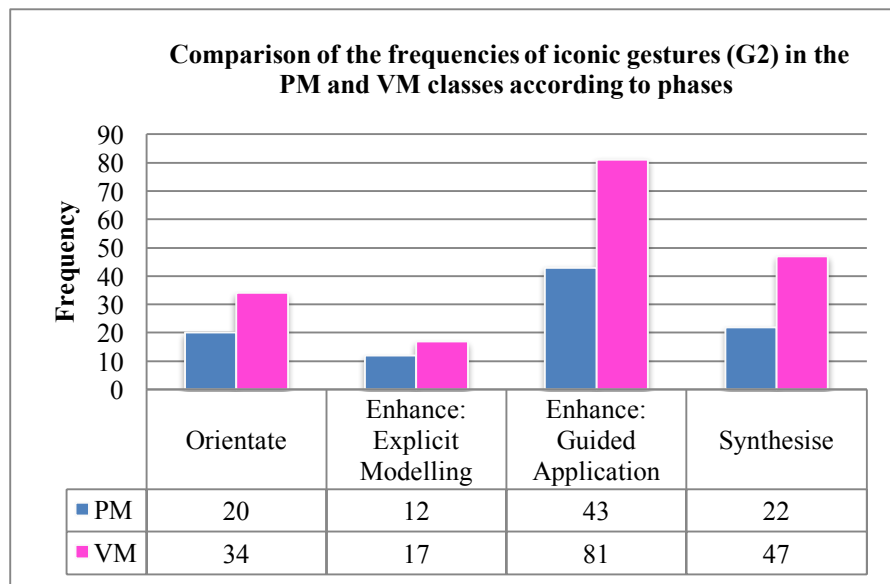

Figure 4.13. Comparison of the frequencies of iconic gestures (G2) in the PM and VM classes according to phases.

Results of a Pearson's chi-squared test indicated that there was no statistically significant difference between the proportion of teacher's use of iconic gestures (G2) in the PM and VM classes ( $\chi^2(3) = .913, p = .833$ ) across the four phases. However, Figure 4.13 indicates that the frequency of use in the VM class was significantly greater in all phases of the lesson (e.g., Enhance: Guided Application PM:VM = 43:81; Synthesise PM:VM = 22:47).

Next, the total frequencies of gestures (i.e., all six gesture categories) were analysed according to each of the four lesson phases. These are presented in Figure 4.14.

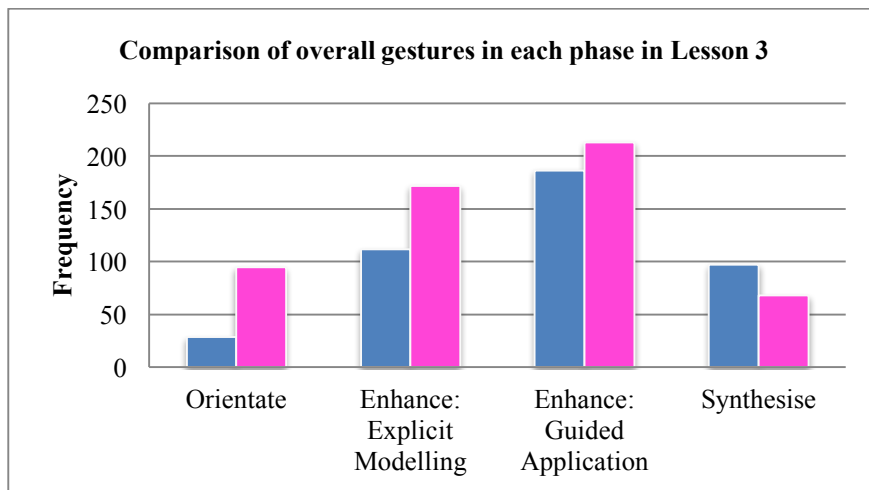

Figure 4.14. Comparison of total frequencies of all gestures in each phase in Lesson 3.

Results from the Pearson's chi-squared test indicated that there was a statistically significant difference between the teacher's use of gestures in each lesson phase in the PM and VM classes ( $\chi^2(3) = 30.928, p = <.01$ ). The frequencies and percentage frequencies of the teacher's overall gesture use in each phase of Lesson 3 are presented in Table 4.57.

Table 4.57

*Frequency and Percentage Frequency of Overall Gestures Used by the Teacher in Each Phase of Lesson 3 in the PM and VM Classes*

Phase	Frequency		Percentage	
	PM	VM	PM	VM
Orientate	28	95	7	17
Enhance: Explicit Modelling	112	172	27	31
Enhance: Guided Application	186	213	46	40
Synthesise	81	68	20	12
TOTAL	407	548	100	100

The frequencies presented in Table 4.57 indicate that the teacher used more gestures:

1. in the Orientate phase in the VM class, where the percentage frequency of gestures as a proportion of all gestures used in that class was more than double the proportion observed in the PM class (i.e., PM:VM = 7%:17%); and
2. in the Synthesise phase in the PM class, where the percentage frequency of gestures as a proportion of all gestures used in that class was almost double the proportion observed in the VM class (i.e., PM:VM = 20%:12%).

Presented in Figure 4.15 is a comparison of the gestures used in the PM and VM classes during the Orientate phase.

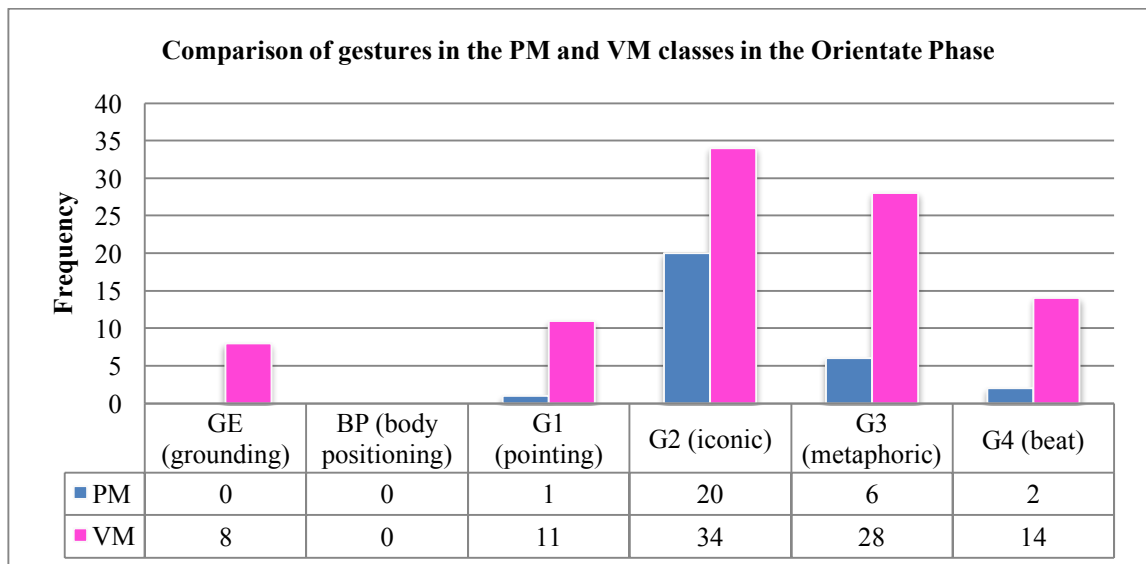

Figure 4.15. Comparison of gestures in the PM and VM classes in the Orientate phase.

Pearson’s chi-squared test could not be used to analyse the frequencies of gestures in the Orientate phase. However, the differences presented in Figure 4.15 indicate increased use of all gestures (except BP: body positioning) in the VM class (e.g., G1 [pointing] PM:VM = 1:11; and G3 [metaphoric] PM:VM = 6:28).

Figure 4.16 presents a comparison of the gestures in the PM and VM classes during the Synthesise phase.

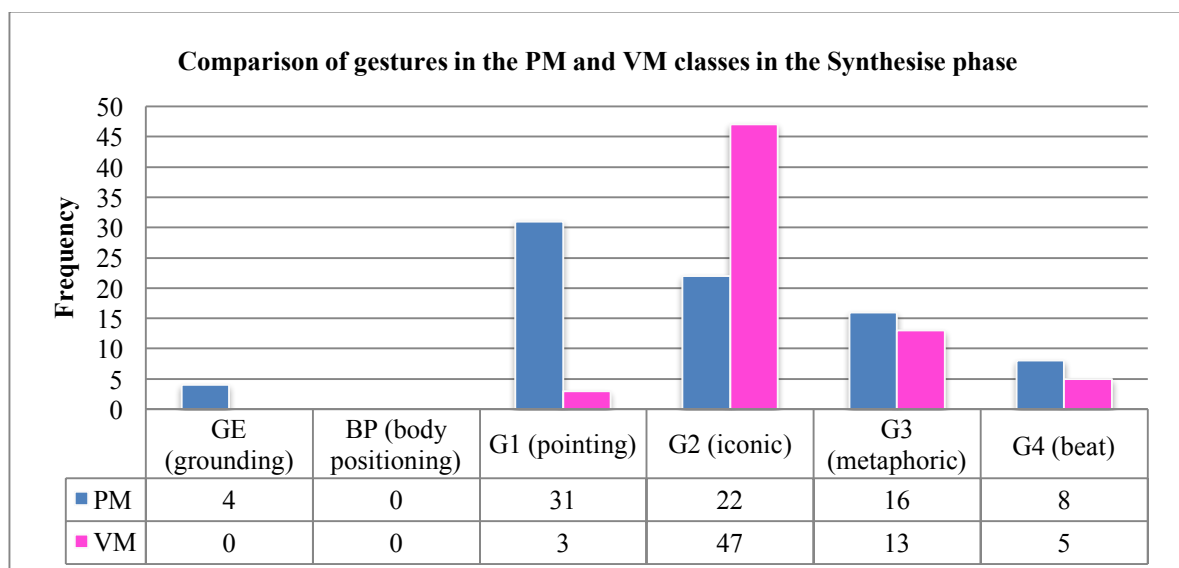

Figure 4.16. Comparison of gestures in the PM and VM classes in the Synthesise phase.

Pearson’s chi-squared test could not be used to analyse the frequencies of gestures in the Synthesise phase. However, the differences presented in Figure 4.16 indicate the teacher’s increased use of:

1. grounding (GE), pointing (G1), metaphoric (G3) and beat (G4) gestures in the PM class, where pointing (G1) gestures were used ten times more frequently than in the VM class (i.e., G1 [pointing] PM:VM = 31:3); and
2. iconic gestures (G2) in the VM class, with the frequency of use more than double that in the PM class (i.e., G2 [iconic] PM:VM = 22:47).

Overall, analysis of the teacher's use of gestures revealed several differences between the PM and VM class. The analysis indicated that:

1. The PM class:
  - (a) used more grounding (GE) gestures than the VM class, particularly in the Enhance: Guided Application and Synthesise phases. This appears to be related to the use of physical manipulatives. When students struggled with a concept or needed a misconception modified, the teacher used the scaffold *meaningful contexts* (2RsA) and *grounding gestures* (GE) to interact with the physical manipulative to assist students' spatial thinking (see section 4.3.2.1); and
  - (b) in the Synthesise phase, used more gestures than the VM class, particularly pointing (G1) gestures.
2. The VM class:
  - (a) overall, used more gestures than the PM class, particularly iconic (G2) gestures;
  - (b) in the Orientate phase, used more of all gesture categories (except BP) than the PM class; and
  - (c) in the Synthesise phase, used more iconic (G2) gestures than the PM class.

Figure 4.17 presents a summary of the findings when comparing the mathematical words and visual mediators for the PM and VM classes.



<b>Summary of findings when comparing mathematical words and visual mediators for the two classes</b>
<p><b>Special keywords</b></p> <p><b>Overall:</b> In all lesson phases a significantly greater range of different <i>special keywords</i> were used in the VM class, and their frequency of use was greater in the VM class.</p>
<p><b>Visual mediators</b></p> <p><b>Overall:</b> More gestures were used in the VM class. There was a significant difference in the types of gestures used in the two classes. Significantly more <i>grounding gestures</i> (GE) were used in the PM class. Significantly more <i>iconic gestures</i> (G2) were used in the VM class.</p>
<p><b>Phases</b></p> <p><b>VM class:</b> Significantly greater use than in the PM class of all gestures (<i>grounding, pointing, iconic, metaphoric</i> and <i>beat</i>) in the Orientate phase. Significantly greater use of <i>iconic gestures</i> (G2) in the Synthesise phase.</p> <p><b>PM class:</b> Significantly greater use than in the VM class of <i>grounding</i> and <i>pointing</i> gestures in the Synthesise phase.</p>
<p><b>Gestures (GE and G2)</b></p> <p><b>VM class:</b> Greater use than in the PM class of <i>grounding gestures</i> (GE) in the Orientate phase. Greater use of <i>iconic gestures</i> (G2) in all phases.</p> <p><b>PM class:</b> Greater use than in the VM class of <i>grounding gestures</i> (GE) in the Enhance: Guided Application and Synthesise phases.</p>

Figure 4.17. Summary of findings when comparing mathematical words and visual mediators for the two classes.

## 4.4 CHAPTER REVIEW

This chapter has presented an analysis of the data from the spatial abilities testing material (i.e., quantitative data) and an analysis of the scaffolding practices used by the teacher in the teaching experiment lessons (i.e., qualitative data). Analysis of these data revealed that the use of different external representations (i.e., PM or VM) influenced a number of teaching and learning factors in the classroom. A summary of these findings is presented in two sections:

1. influence of PM and VM representations on students' spatial thinking; and
2. how the teaching (i.e., teacher scaffolding practices) changed from the PM class to the VM class.

### 4.4.1 Influence of representations (PM and VM) on students' spatial thinking

*Finding: The use of external representations appeared to positively influence students' spatial thinking.*

Results from the quantitative data of this study indicated that the use of external representations, either physical or virtual, were beneficial to students' learning of spatial concepts. Over the course of the study, both the PM class and the VM class made statistically significant improvements compared to the Control class; however, no statistically significant difference was found between the PM class and the VM class. Furthermore, these improvements made from pre- to post-testing were maintained over a six-month non-intervention period.

#### **4.4.2 How the teaching (i.e., teacher scaffolding practices) changed from the PM class to the VM class**

The analysis of the teacher's use of scaffolds revealed several general findings.

*Finding: The type of representations used in teaching appeared to influence the types of teacher scaffolding that occurred.*

While the teacher tried to implement a similar lesson structures in both classes during the teaching experiment, the use of different external representations (PM and VM) appeared to influence the types of scaffolding practices implemented. Using PM resulted in a more directed approach to teaching, where scaffolding practices followed a linear pattern, sequentially progressing to higher levels (see Figure 4.2). In contrast, using VM resulted in a more organic and fluid implementation, which appeared more responsive to students' needs. The use of technological scaffolds (embedded features in the iPad apps) in the VM class changed the teacher's role as MKO (see section 4.3.2.2, Phase 1 – Orientate: Change of emphasis in Level 2 scaffolds). This resulted in changes in *routines* (i.e., the social and cultural interaction in the classroom), such as students adopting more responsibility for their learning by peer scaffolding (see Table 4.43, section 4.3.2.2, Phase 1 – Orientate: Students becoming active engagers in the scaffolding process).

*Finding: A change in the teaching influenced the depth of discussion that occurred.*

When the teacher implemented higher levels of scaffolding (i.e., Level 3: *developing conceptual thinking*) students participated in more in-depth (conceptual) discussions related to spatial thinking. In the PM class, Level 3 scaffolding practices were beginning to be implemented in the Synthesise phase. By contrast, VM students were exposed to Level 3 scaffolds from the Orientate phase (see section 4.3.2.2, Phase 1 – Orientate: Inclusion of Level 3 scaffolds). This resulted in a greater depth of mathematical discussions throughout all phases of the VM lessons.

*Finding: A change in the teaching influenced the types of communication used.*

Analysis of the teacher's communication indicated changes in the use of both *mathematical words* and *visual mediators*. In relation to mathematical words, VM students were not only exposed to a greater variety of *special keywords*, but these different *special keywords* were used more frequently and in earlier phases of the lesson than in the PM class. In relation to *visual mediators*, using VM resulted in the teacher using more gestures overall than in the PM class.

In the next chapter, the findings related to students' learning are presented and analysed according to their communication, that is, Sfard's (2008) characteristics of mathematical discourse.



# Chapter 5: Findings – Student Learning

---

## 5.1 CHAPTER OVERVIEW

In this chapter, findings of the study pertaining to students’ spatial thinking and learning are presented. The chapter comprises three sections. In the first section, examples illustrating different types of communication that drove the analysis of the data are presented. It should be noted that although these examples have been drawn from the PM class, the same types of communication existed in the VM class. In the second section, findings pertaining to the types of communication of learning used by students from the PM class and VM class are shared and compared. In the final section a summary of the findings is presented and the emergent themes that drove the discussion of these findings in Chapter 6 are provided. A visual overview of the chapter is presented in Figure 5.1.

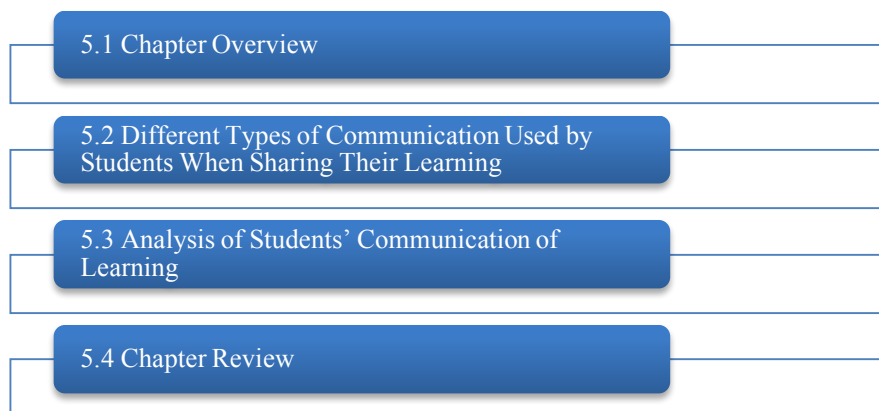

Figure 5.1. Overview of Chapter 5.

## 5.2 DIFFERENT TYPES OF COMMUNICATION USED BY STUDENTS WHEN SHARING THEIR LEARNING

The focus of this analysis was to identify trends in the different ways students communicated their learning. According to Sfard (2008), students rely on two forms of communication, *mathematical words* and *visual mediators*. In the analysis, these forms of communication are evidenced by students’ verbal communication (students’ utterances) and non-verbal communication (students’ gesture) (see sections 2.7.2.1 and 2.7.2.2). Therefore, students’ communication was analysed by the changes that occurred in these two characteristics of mathematical discourse. Analysis of these two characteristics was conducted through *focal analysis* (Sfard, 2002a) by examining the *pronounced*, *intended* and *attended* foci of students’ communication (see section 3.7.2). Visual mediators, in this instance gestures, were coded

according to six gesture categories based on McNeill's (1992) classifications (see sections 2.7.2.2 and 5.2.2). Table 3.8 (see section 3.7.2) provides a list of the codes used in the transcripts for each of these gesture classifications, as well as a brief description of the gesture type. This approach allowed for detailed understanding of the changes in students' non-verbal communication.

Analysis of students' communication is presented in two subsections. Examples of each level of mathematical words and each category of gesture (i.e., visual mediator) identified in the analysis are presented in subsections 5.2.1 and 5.2.2 respectively. In the next section, section 5.3, the findings pertaining to students' communication of their learning are presented. This section predominantly focuses on how the VM students' communication of learning differed from the PM students' communication of learning. At the conclusion of section 5.3, a summary of the comparison between the two groups of students (PM and VM) is presented. The specific aim of this analysis was to examine the influence that each external representation has on promoting the spatial thinking of young students, in particular their communicational approach to learning.

### **5.2.1 Delineating the levels of sentence structure within mathematical word analysis**

The first form of communication that emerged from the analysis of the data was the changes that occurred in students' use of *mathematical words* as they progressed through the lessons. Students' *mathematical words* were examined through two main constructs. The first related to the grammatical complexity of sentences they used and the second related to students' use of *special keywords*. For this study, these *special keywords* are the mathematical vocabulary commonly used in mathematics classrooms. In the context of spatial orientation and visualisation, special keywords include such words as *line*, *round*, *shape*, *edges* and positional language used to describe the orientation of objects.

The analysis of the grammatical complexity of sentences used by students in their mathematical discourse were adapted from the stages of linguistic development (Matthews, 1996) into four levels of sentence structure (see section 2.7.2.1). These were identified as:

1. limited use of language;
2. simple sentences and short phrases;
3. complex sentences (including the use of circumstances); and
4. questioning.

The types of questioning related to Level 4 were the questions where students were exhibiting self-modifications to their learning. Holton and Clarke (2006) suggest the use of questioning

shows a progress towards metacognition (i.e., students are thinking about their own thinking processes). Formulation of a question seems to require a student to think about what they already know and search for further information to extend it. Thus, questioning was considered to be at the highest level.

The analysis of the levels is presented in the following subsections aligning with each of these four levels of sentence structure.

### 5.2.1.1 Limited use of language

Students' limited use of language appeared to be related to students' limited mathematical vocabulary. This was mainly evident through students substituting other words or gestures for *special keywords*. These two forms of substitution were commonly demonstrated by (a) students using pointing gestures; and (b) students using non-specific words (e.g., *this, that, here, there*). Table 5.1 provides an extract showing how students used pointing gestures and non-specific words (G1) to refer to the special keywords *cube, beside, behind, cylinder*. This occurred in the Orientate phase of the first lesson (LISO PM 8; see Appendix F for the full lesson). In this lesson students were asked to describe the relative position of several 3D objects from a particular orientation (e.g., front view, back view or side view).

Table 5.1

*Students' Limited Language Use (LISO PM 8: Utterance 5–8), Orientate Phase*

Utterance	Verbal communication	Gesture (non-verbal communication)
5	T Which is the cube? Tell me about it.	
6	S23 ...	Points to the cube
7	T Yes, but tell me where it is?	
8	S23 It is here.	Touching the cube. Student returns to drawing but touches each object before drawing it on the paper.

Evident in Utterance 6, S23 responds to the teacher's question using non-verbal communication (G1). When the teacher asked the student to use words to tell where the cube was (Utterance 7), S23 did not use *special keywords* to describe the position of the cube but responded with "here" (Utterance 8). Importantly, the use of gesture as a form of communication informed the teacher that the student was aware of the spatial concept, *cube*, however seemed unsure of the positional language required to describe its location.

### 5.2.1.2 Simple sentences and short phrases

The next level comprises students using simple structured sentences that contain a one-word idea (one *special keyword*, e.g., "I see a line"). Table 5.2 provides a vignette illustrating

students' construction of these simple sentences. The vignette is from the same lesson reported in Table 5.1, but in the Enhance: Explicit Modelling phase.

Table 5.2

*Students' Use of Simple Sentences (LISO PM 8: Utterance 46–50), Enhance: Explicit Modelling Phase*

Utterance	Verbal communication	Gesture (non-verbal communication)
46 S15	I see a line.	
47 T	A line?	
48 S15	...	Gestures with hand, a line from one shape to the others G2
49 T	Describe for me the shapes you see.	
50 S15	I see a triangle, a flat area and that.	Points to last shape G1

Utterance 46 provides evidence that S15 used a simple sentence to communicate her ideas about the placement of the 3D objects. In Utterance 48, when S15 was asked to elaborate on her simple sentence, she reverted back to using *iconic gestures* (G2) to communicate her understandings. This finding suggests that when students seem unaware (or under-confident) of the mathematical words to use, they revert back to the earlier level of limited language. In Utterance 50 the use of “triangle” revealed to the teacher that the student was beginning to use spatial language to identify a pyramid and “a flat area” to identify a rectangular prism. However, the use of incorrect terminology (flat area) and the use of “that” to identify a cylinder indicated to the teacher that gaps still existed in S15’s communication of her knowledge about spatial concepts.

Another common occurrence during this second level of sentence structure development included students’ communication consisting of simple phrases. Instead of single-word utterances, students began to express their understanding in short, three-to-four-word utterances. These often began as prepositional phrases voiced as questions (i.e., evident through students’ inflection), and as understanding of the spatial concept was evidenced, these phrases developed into statements. Table 5.3 provides an example of these short phrases. This occurred in Lesson 3 where students were describing an arrangement of Lego bricks from different orientations.

Table 5.3

*Students' Use of Short Phrases (L3SO PM 1: Utterance 179–183)*

Utterance	Verbal communication	Gesture (non-verbal communication)
179 S1	Over there?	Pointing to the left side, with inflection of a question G1
180 T	Where is the purple?	
181 S1	On the left side.	
182 T	On the left side but is it on top of the white or below the white?	
183 S1	On top of it.	



The transcript begins, in Utterance 179, with S1 using a prepositional phrase to communicate his understanding of the spatial orientation of the Lego blocks. The use of this basic phrase allowed S1 to be involved in mathematical discourse on the position of the objects. In this instance, he was unsure of his answer. This was evidenced to the teacher by (a) his use of the nondescript word “there” to describe the position of the block he was trying to describe; and (b) the inflection he used, which denoted his uncertainty about his answer. Change in his utterances (181 and 183), together with the accompanying inflection in his voice, acted to inform the teacher of the level of language usage this student appeared to be at.

### 5.2.1.3 Complex sentences (including the use of circumstances)

In the next level, students began to demonstrate their understanding of spatial concepts through the use of more complex sentence structures. This predominantly included the use of circumstances. Circumstances are prepositional phrases that function to express *how*, *when*, *where*, and *why* meanings. This development of language was most observable during the Enhance: Guided Application phase where the lesson became less teacher-directed. Table 5.4 illustrates an example of the use of a complex sentence structure that contained circumstances. This vignette is from Lesson 3 where students were discussing the position of Lego bricks from a set viewpoint (e.g., side view). The circumstances used by the student have been underlined.

Table 5.4

*Students’ Use of Circumstances (L3SO PM 7: Utterance 27–28), Enhance: Guided Application Phase*

Utterance	Verbal communication	Gesture (non-verbal communication)	
27	S12 I can see (a) .... the side on ..., (b) <u>on the right side</u> .	(a) Moves behind the dog to view (b) Places hand on ground next to the right side of the model	BP GE
28	T On the right side. Lovely language.		

Utterance 27 evidenced S12’s beginning use of circumstances within a more complex sentence structure. In this example, the student was using a circumstance of *where* (“on the right side”) to express his understanding of position to the teacher. It is through the use of these more complex sentences that students’ understandings of the spatial concept of orientation were effectively communicated to the teacher. From this student’s more advanced sentence structure, the teacher was able to interpret the extent of his understanding of position.

#### 5.2.1.4 Questioning

The final level relates to the formulation of questions for exploring spatial aspects of a situation. This use of questions generally resulted in students providing evidence of higher levels of thinking and understanding of the spatial concepts. They were starting to self-guide their learning experience. This level required students to structure a full question incorporating the use of such words as *who*, *what*, and *how*. Examples of students' questioning were evident in the fifth lesson. This lesson involved students identifying the features of 3D objects, including the faces of the 3D objects. Examples included:

64 S17 But what if another shape has al...also eight edges? (L2SV PM 5)

98 S17 How does that count as a face? (L2SV PM 5)

When students started to use these types of questions, the teacher was able to make judgements about their conceptual understanding and evaluate which ideas within the spatial concept needed to be further explored. Questions also allowed the teacher to easily identify areas of misconceptions. This stage of sentence structure development was mainly evident in the final phases of the lessons.

#### 5.2.2 Delineating the types of gestures identified in the visual mediator analysis

Six gesture classification categories were used to analyse the visual mediators used by students. The first two McNeill (1992) classified as non-gestures; however, through Sfard's (2008) understanding of the communicative function of gestures, these have been included in the coding structure (see section 2.7.2.2). Briefly, these were as follows:

1. Grounding gestures (GE), which include any action where the student is physically interacting with the manipulative.
2. Changes to body positioning (BP), which include bodily movements that change the position of a student's body.
3. Pointing gestures (G1), which are context dependent and often used with deictic terms, such as *here* or *there*. These are gestures where students use finger or whole hand motions towards an object (either real or imagined).
4. Iconic gestures (G2), which are representational gestures that bear a resemblance to the concrete objects being referred to.
5. Metaphoric gestures (G3), which are similar to iconic gestures as they make reference to a visual image; however, these images relate to abstract ideas.

6. Beat gestures (G4), which are simple, non-pictorial gestures that include a repeating motion used to emphasise certain parts of utterances.

The following subsections present vignettes from the videos providing examples of the types of gestures students used in their communication of their learning. It should be noted that although these vignettes are drawn from the PM class, with the exception of beat gestures, the same types of examples existed in the VM class. Beat gestures were only observed in the VM class.

### ***5.2.2.1 Grounding (GE) or changing body positioning (BP) in relation to the physical materials***

When a spatial concept was first introduced (e.g., spatial orientation), students communicated their spatial understandings by physically interacting with the physical materials. These interactions included touching the physical manipulative to ground students' thinking to the environment or changing their body position to change their view of the object. In this early phase of spatial development, the act of interacting with the physical object was how students communicated their spatial thinking. Students predominantly used gesture as the communicational function. An example of this physical interaction was evident in the first spatial orientation lesson in the PM class. This first lesson involved students describing the relative position of a variety of 3D objects in relation to each other. The teacher had asked students to describe the position of the cube in relation to the other 3D objects that were situated on the table. Table 5.5 provides a vignette where S23 used *grounding* (GE) to communicate her spatial thinking.

Table 5.5

*Students' Use of Grounding Gestures (LISO PM 8: Utterance 5–8)*

Utterance	Verbal communication	Gesture (non-verbal communication)		
5	T	Where is the cube? Tell me about it.		
6	S23	...	Points to the cube	G1
7	T	Yes, but tell me where it is?		
8	S23	It is here.	Touching the cube. Student returns to drawing but touches each 3D shape before drawing it on the paper.	GE GE

In Utterance 6, S23 used a gesture of *pointing* (G1) to refer to the object. As evidenced in the vignette, her use of mathematical words was non-existent. Therefore, this gesture was communicating her thinking. Even after S23 began to use verbal communication (Utterance 8), she still relied on her ability to touch each shape, that is, she used *grounding* (GE) to help her think about the positional orientation of the shape. While it was evident in the student's actions

that she had some idea about position, it was also evident to the teacher that S23 seemed to lack the verbal language to communicate this.

In addition, when students were asked to describe an object from a different viewpoint, PM students relied on the act of changing their *body position* (BP) to assist their spatial learning. Figure 5.2 provides an example of students voluntarily changing their body position to assist their spatial thinking. The task involved students describing the position of Lego bricks on a concrete model from different viewpoints (e.g., side view [dog], front view [kangaroo], top-down view [bird]).



Figure 5.2. PM students' changes to body positioning (BP) (video data L3SO PM 1).

When the teacher asked students what the model looked like from the dog's side view, most students moved their head down to floor level (the first image) to assist them with "seeing what the dog saw". The second image shows how students moved back to a sitting position when asked to describe the kangaroo's front view of the model. When the teacher then asked students to describe the bird's top-down view, all students stood up to see the object from that viewpoint (image 3). The changes in students' body positions indicated that these students used BP to allow them to describe a perspective through a direct line of sight rather than visualising the change in perspective.

### 5.2.2.2 Pointing at objects (G1)

The use of *pointing gestures* (G1) was another common occurrence when students seemed to lack the language skills to describe their spatial thinking. This is illustrated in Table 5.1 and Table 5.2. Often, *pointing gestures* (G1) were used in conjunction with deictic words, such as *this*, *that* and *there*, to communicate students' spatial thinking. Figure 5.3 provides examples of students' use of pointing gestures.

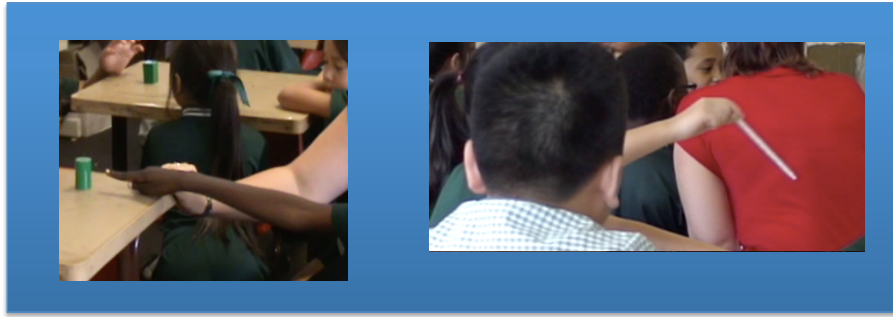

Figure 5.3. Examples of pointing gestures (G1).

In the clip shown in Figure 5.3 students were asked to describe the position of the 3D objects (e.g., “describe where the pyramid is”). In image 1 the student simply pointed to the cylinder instead of describing its position in terms of its relationship to other 3D objects. At times, instead of using their finger to point, they used an object like a pencil as an extension of their hand/fingers. This can be seen in image 2.

### 5.2.2.3 Pointing to the object as a reference (G1a)

At this stage there was a need to nuance McNeill’s (1992) *pointing gesture* category. From the analysis of the data, pointing gestures appeared to serve two distinctly different purposes. In the first instance, *pointing gestures* (G1) were used when students appeared to lack the vocabulary or language skills to effectively communicate their spatial thinking verbally. In the second instance, *pointing gestures* (G1a) occurred when students possessed the correct words to verbally communicate their response and were using the *pointing gesture* as a clarification for listeners by referring to the physical material being verbally referenced. The use of *pointing gestures* in this manner informed the teacher that (a) students possessed the language and were confident in using it at a sufficient level to engage in mathematical discourse without the aid of *iconic gestures*; and (b) students were beginning to rely less on *iconic gestures* to assist them to create internal representations of the concrete stimuli. It appeared that as these students created an internal visual representation, they used the pointing gesture to ground their thinking back to the environmental stimuli of the physical material. An example of this was evident in the third spatial orientation lesson with the PM class during the final section of the Enhance: Guided Application phase. Table 5.6 presents a vignette of a transcript from a task where students were describing the position of Lego bricks from different orientations (i.e., top-down view, side view, etc.).

Table 5.6

*Students' Use of Pointing Gestures (L3SO PM 7: Utterance 92–94)*

Utterance	Verbal communication	Gesture (non-verbal communication)	
92	S6 Uh, in the .... uh, .... (a) left uh, ... purple. Um, in the ..... bottom .... left-hand corner.	(a) Points at the model while standing over it	G1a
93	T Good describing.		
94	S6 (a) In the bottom left-hand corner ..... and then a brown and the red one and the green.	(a) Points to model	G1a

Utterance 92 shows how S6 used *pointing* to the object as a reference (G1a) in conjunction with formulation of his language to describe the position of the blocks. This form of pointing gesture indicated to the teacher that the student still required the act of pointing to help him express his thinking. It seemed that S6's use of the pointing gesture was acting as a trigger to help him connect the visual images that he could see in the Lego bricks to his internal visual images, and to support the communication of what he knew to the teacher. Utterance 94 illustrates how he no longer required the physical interaction with the concrete object to communicate his spatial thinking. In this instance, he used pointing gestures to ensure that his peers followed his thinking. Figure 5.4 illustrates the pointing motions used by S6 when he verbally communicated the positions of the blocks. S6 is the person standing up with the purple wristband on his left hand and watch on his right hand.

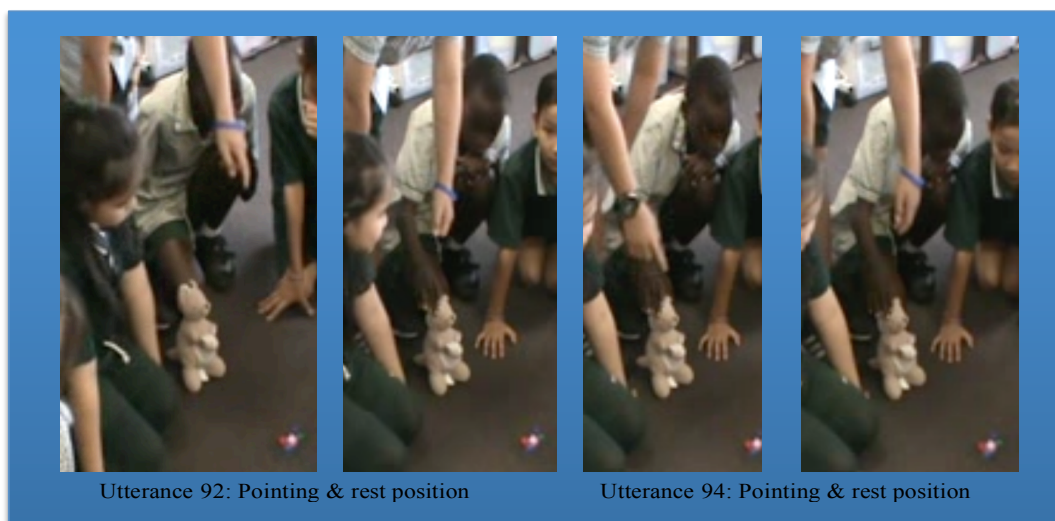

Figure 5.4. Example of pointing gestures (G1a) with appropriate language.

#### 5.2.2.4 Iconic representation of the object (G2)

As the lesson progressed and students adopted a more active role in the explanation of spatial concepts, the use of *iconic gestures* (G2) became more prevalent. The use of iconic

gestures occurred for two reasons. First, iconic gestures were used as a clarifying tool (for both the interlocutor and the listener). Second, iconic gestures were used to help students express an idea when they seemed to lack the verbal language for effective communication. In both instances, iconic gestures provided an opportunity for these students to engage in the mathematical discourse even though they were unsure about their language skills. Table 5.7 highlights the relationship between students' use of gestures and their use of language when communicating their spatial ideas. S3 was describing the position of a rectangular prism in relation to a cylinder that was placed on top of the desk.

Table 5.7

*Students' Use of Iconic Gestures (L3SO PM 7: Utterance 57 and 72)*

Utterance	Verbal communication	Gesture (non-verbal communication)	
57	S3 ..... I see a (a) flat side  (b) here.	(a) Motions with a flat hand, palm towards self, down the closest edge of the rectangular prism (b) Points to the edge of the shape	G2  G1
72	S3 This one is closer than this one.	Points first to the rectangular prism and then to the cylinder	G1

Utterance 57 shows that although the student does not use the words *faces* and *edges* to describe the 3D object, her use of *iconic gesture* (G2) evidenced her understanding of the idea. Figure 5.5 demonstrates the *iconic gesture* used by this student to indicate the rectangular face of the prism.

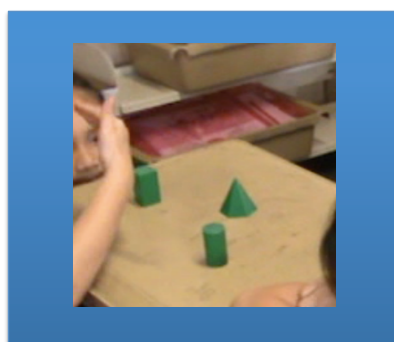

Figure 5.5. Example of iconic gesture.

Further evidence of this occurrence is presented in Table 5.8 and Figure 5.6. Table 5.8 presents another example of *iconic gesture* (G2) usage, where the student used an iconic gesture to assist her to communicate the notion of *flip*. This occurred in the last lesson on symmetry. S2 was explaining the difficulty she was experiencing in drawing the mirror image of a symmetrical pattern. She was having difficulty in finding the word to express her thinking.

Table 5.8

*Students' Use of Iconic Gestures (L3SO PM 7: Utterance 36)*

Utterance	Verbal communication	Gesture (non-verbal communication)
36 S2	Um, ..... I wasn't able to flip it over.	Places palm facing down above the table and flips so palm is then facing up. Flips hand again back to starting position.

It appeared that the gestural act of moving her hand to iconically represent what she was visually thinking helped her formulate the notion of *flip*. Figure 5.6 shows the iconic gesture used by S2 to assist her mathematical discourse.

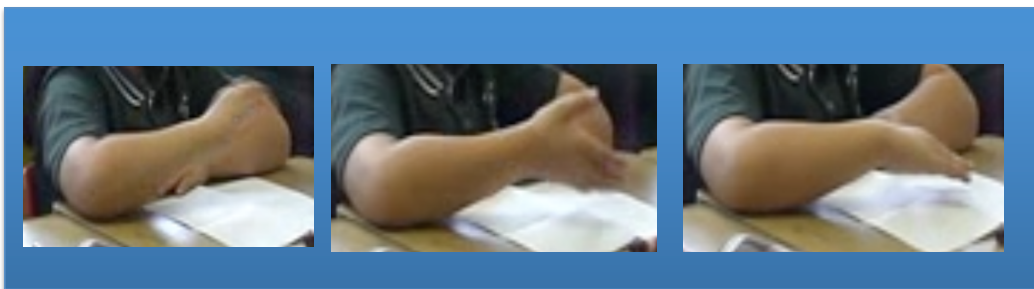

Figure 5.6. Example of iconic gesture (G2) for “flip it over”.

### 5.2.2.5 The use of metaphoric gestures

Within the PM class, the use of *metaphoric gestures* (G3) was mainly related to subconscious movements to visually show the teacher that students were thinking (i.e., communicating with oneself) or unsure about their thinking (e.g., placing hand to head/chin/mouth, playing with hair, fiddling with fingers). Table 5.9 presents an example of S33's use of a *metaphoric gesture* (G3) when she was unsure of her response.

Table 5.9

*Example of Metaphoric Gesture Use in the PM Class (L3SO PM 1: Utterance 190)*

Utterance	Verbal communication	Gesture (non-verbal communication)
190 S33	I think. Then pink.	Fiddling with fingers

In Utterance 190, S33 was unsure of her response, therefore started to fiddle with her fingers.

Table 5.10 illustrates the *metaphoric gesture* (G3) used by S54 when he was thinking about what his answer would be to the teacher's question of what the Lego bricks looked like from the dog's side view.



Table 5.10

*Student's Use of a Metaphoric Gesture (L3SO PM 1: Utterance 200)*

Utterance	Verbal communication	Gesture (non-verbal communication)		
200	S54	(a) Ummm ...	(a) Places hand on floor near concrete model	GE
		(b) The dog can	(b) Places hand on chin	G3
		(c) see the green and	(c) Points at the model	G1a
		(d) .....	(d) Looks to another student	
		(e) red on top.	(e) Takes right hand off chin and makes a claw shape just above the floor.	G2

In Utterance 200(a), S54's pause in communication of his response (i.e., "Ummm ...") was interpreted by the teacher that he was experiencing difficulties in formulating an answer to the question. S54 then used a *metaphoric gesture* (G3) of placing his hand on his chin, to indicate that he had to think carefully about what he wanted to say. As students' use of *metaphoric gestures* (G3) did not appear to be directly related to helping them to communicate their spatial thinking to others, these types of G3 gestures were not included in the presentation of these findings.

However, this changed in the VM class; an example of students' use of *metaphoric gestures* (G3) is presented in Table 5.18 in section 5.3.1.2, when differences between the classes are examined.

### 5.2.2.6 Beat gesture

*Beat gestures* (G4) were not observed in the PM class, and rarely occurred in the VM class. When *beat gestures* occurred, they were used to emphasise a particular part of an utterance. Table 5.11 presents an example of a VM student's use of *beat gestures* (G4) while describing a previous lesson's activity, which involved identifying the coloured faces of a cube from different viewpoints.

Table 5.11

*VM Student's Use of Beat Gestures (L3SO VM 9: Utterance 33)*

Utterance	Verbal communication	Gesture (non-verbal communication)		
44	S29	We had to		
		(a) get a paper and	(a) Right hand moves like grabbing a piece of paper	G2
		(b) write	(b) Raises right hand up and then down like a writing motion	G2
		(c) the <b>front</b> and, <b>back</b> , and <b>bottom</b> and the	(c) Both hands move across body in beats from left to centre of the body	G4
		(d) top and	(d) Bounce hand in centre position	G4
		(e) colour it in.	(e) Both hands move to the right of body	G2

*Iconic* (G2) and *beat gestures* (G4) were used by S29 to accompany her explanation. In Utterance 44(a) and 44(b), S29 created an *iconic gesture* (G2) to visually represent (a) grabbing a piece of paper for the verbal expression of “get a paper”; and (b) a writing motion to aid the communication of “write”. *Beat gestures* (G4) were then used by S29 in Utterance 44(c) to emphasize the *special keywords* used in describing the positions.

### 5.3 ANALYSIS OF STUDENTS’ COMMUNICATION OF LEARNING

In order to compare the communication of students’ learning in the PM and VM classes, transcripts from the same lesson used in Chapter 4 (Lesson 3) within each sequence were selected. The videos from each class (PM and VM) were analysed using the categories delineated in section 5.2. A full description of Lesson 3 is presented in Appendix F. Briefly, the lesson entailed students examining 3D models from different orientations and using language to describe these “points of view”. Analysis of the differences between students’ communication of learning in the PM class and the VM class is presented in the following subsections. The first subsection compares students’ communication and identifies differences, while the second explores the influence of these differences on the teaching.

#### 5.3.1 Comparing PM and VM students’ communication of learning

This section presents differences that occurred in the PM students’ and VM students’ communication of learning (i.e., use of *mathematical words* and *visual mediators*). The findings are presented in three parts. In the first part, the PM and VM classes’ use of *mathematical words* is compared. In the second part, differences in the PM and VM students’ use of *visual mediators* (i.e., gestures) are reported. A summary of the changes and differences in PM and VM students’ communication of learning, including the relationship between their use of *mathematical words* and their use of *visual mediators*, is provided in the final part.

##### 5.3.1.1 Analysis of differences between PM and VM students’ use of mathematical words

The analysis of the first characteristic of *mathematical words* involved examination of the sentence structures used by the PM and VM students.

##### *Differences between PM and VM students’ sentence structure*

The four sentence structure levels used to examine changes in students’ utterances were (a) limited language, (b) short phrases and simple sentences, (c) complex sentences, and (d) questioning. Figure 5.7 presents the number of times each sentence structure level was

observed in the PM and VM classes during each lesson phase. The figure has been colour coded to represent high usage ( $\geq 20$  = blue), medium usage (10–19 = green) and low usage (1–9 = yellow). The final column presents the number of times that sentence structure was used by students across Lesson 3 (coloured grey). The diagonal shading has been used in instances for the VM class when the frequencies of word usage for the PM and VM classes were colour coded differently.

		Learning phases									
		Orientate		Enhance: Explicit Modelling		Enhance: Guided Application		Synthesise		TOTAL	
		PM	VM	PM	VM	PM	VM	PM	VM	PM	VM
Types of sentence structures	Questioning	0	0	0	1	1	2	2	0	3	3
	Complex sentences (with circumstances)	2	8	2	5	9	51	12	8	25	72
	Phrases and simple sentences	4	4	6	14	30	36	20	6	60	60
	Limited use of language (no words, nondescript and single-word responses)	7	6	19	25	11	10	5	5	42	46

Figure 5.7. Frequency of use of the different sentence structures across Lesson 3 (PM and VM classes).

Figure 5.7 indicates that there was a progression in students' sentence structure levels, and the PM and VM students were communicating the most within the Enhance: Guided Application phase. In the Orientate phase, the PM and VM students' communication comprised *low* usage of the first three levels of sentence structure (i.e., limited language, phrases and simple sentences, and complex sentences). In the Enhance: Explicit Modelling phase, the predominant difference between the PM and VM students was the *high usage* of phrase and simple sentence structures by the VM students (see lined area). During this phase, the iPad acted as a scaffolding agent by providing multimedia instructions of the task, and this seemed to assist students' learning. One VM student also began to formulate a question to extend his or her own learning. Across the whole lesson only three PM and three VM students reached

this level of sentence structure. As the lesson progressed to the Enhance: Guided Application phase, in contrast to the PM students, VM students' communication included *high* usage of complex sentences (see shaded area). This increase in students' communication of their learning provided more opportunities for the teacher to assess student-learning levels. In the Synthesise phase, the reverse trend occurred with the PM students. PM students' use of phrases and complex sentence structures increased whereas VM students' use of phrases and complex sentence structures decreased (see shaded areas).

The most observable difference between the PM and VM students' use of these structures, as evidenced by the total column, was the increased usage of complex sentences across the lesson by VM students (PM:VM = 25:72). Some examples of the complex sentences used by VM students included:

- 42 S45 We had to um, um ... we had to write forward, back, top and bottom and we had to turn it around so we can see what difference does that show (video data L3SO VM 9);
- 68 S30 because if you look at the camera it will tell you where, ... if it's left, right or down to the bottom (video data L3SO VM 9).

In the above vignettes conjunctions and circumstances are underlined. The use of conjunctions indicated that these VM students were developing a sense of relatedness between two ideas. In Utterance 42, S45 used the conjunction "and" to show the multiple steps required to communicate their spatial thinking. The use of conjunctions such as "if" and "so" demonstrated students' understanding of a "cause and effect" relationship. For example, in Utterance 42, S45 indicated that the action of turning the virtual model had the effect of displaying different orientations. In Utterance 68, S30 was revising a previous lesson activity that involved changing camera angles to identify the position of 3D objects. S30 used the conjunction "if" to illustrate the "cause and effect" relationship that looking from different camera angles affects the position of shapes in relation to other shapes. In Utterance 68, S30 used the circumstance of "down to the bottom" to provide extra descriptive information of an object's position. The increased frequency of VM students' use of complex sentence structures provided the teacher with greater information about students' understanding of the concepts. The use of circumstances provided the teacher with evidence of the complexity of these students' understanding of positional language.

### ***Differences between PM and VM students' special keyword usage***

The analysis of the second characteristic of *mathematical words* involved examination of the number of different *special keywords* used (and the frequency of use) in each of the four

phases of Lesson 3 for the PM and VM students. Comparisons of the number of keywords and frequency of use across the phases are presented in Table 5.12. The first number indicates how many different special keywords students used in the phase of the lesson. The number in brackets indicates the frequency of special keyword use in the phase of the lesson. For example, 5(9) indicates that PM students used 5 different special keywords in the Orientate phase of the lesson, and this use occurred 9 times throughout this phase.

Table 5.12

*Number of Different Special Keywords (and Frequency of Use) Used in the Four Phases of Lesson 3 by the PM and VM Students*

Phase	No. of different special keywords (frequency of use)	
	PM students	VM students
Orientate	5 (9)	16 (25)
Enhance: Explicit Modelling	3 (6)	14 (20)
Enhance: Guided Application	13 (40)	31 (84)
Synthesise	7 (10)	17 (21)
Total	28 (65)	78 (150)

Results of the Pearson’s chi-squared test indicated there was no statistically significant difference between the proportion of different special keywords used in the PM and VM classes ( $X^2(3) = 1.012, p = .828$ ) across the phases. However, Table 5.12 also clearly shows that there were many more different keywords used by the VM students in all phases of the lesson (e.g., Enhance: Explicit Modelling PM:VM = 3:14; Synthesise PM:VM = 7:17). In addition, VM students started to use general terms, such as “position” and “direction” earlier in the lesson phases. VM students also extended *special keywords* by joining two together to give a more detailed description of position (e.g., bottom left, top right-hand corner). This extension included the use of sentence starters, such as “first”, “second”, “next” and “last”, to indicate when tasks were to be completed in relation to steps or order (see Appendix R).

Results from a Pearson’s chi-squared analysis on the frequency of *special keyword* used by students indicated that there was no statistically significant difference between the PM and VM classes ( $X^2(3) = 1.161, p = .773$ ), that is, the proportional change in frequency of use was similar across the two classes. However, as presented in Table 5.12, the frequency of *special keywords* used by students in the VM class increased in between the order of 2 to 3 times in each phase (e.g., Orientate PM:VM = 9:25; Enhance: Explicit Modelling PM:VM = 6:20; Enhance: Guided Application PM:VM = 40:84; and Synthesise PM:VM = 10:21).

**5.3.1.2 Analysis of differences between PM and VM students' use of visual mediators (gestures)**

The second characteristic of the students' communication analysed was the differences that occurred in their use of *visual mediators* (i.e., gestures). These gestures were coded using six gesture classifications (see section 5.2.2). The frequency of each gesture classification in each of the four lesson phases is presented in Table 5.13 and Table 5.14.

Table 5.13

*Frequency of Each Gesture Category Used by PM Students During Each Phase of Lesson 3*

	GE (grounding)	BP (body positioning)	G1 (pointing)	G2 (iconic)	G3 (metaphoric)	G4 (beat)	Total
Orientate	0	0	0	0	0	0	0
Enhance: Explicit Modelling	0	1	0	0	0	0	1
Enhance: Guided Application	8	19	24	9	10	0	70
Synthesise	0	0	0	2	0	0	2
Total	8	20	24	11	10	0	73

Table 5.14

*Frequency of Each Gesture Category Used by VM Students During Each Phase of Lesson 3*

	GE (grounding)	BP (body positioning)	G1 (pointing)	G2 (iconic)	G3 (metaphoric)	G4 (beat)	Total
Orientate	0	0	1	8	2	1	12
Enhance: Explicit Modelling	0	1	11	7	2	1	22
Enhance: Guided Application	13	2	40	36	6	2	99
Synthesise	0	0	0	13	2	0	15
Total	13	3	52	64	12	4	148

There were several observable differences between the PM and VM classes. For the PM class, nearly all gestures occurred in the Enhance: Guided Application phase of the lesson, with the BP (body positioning) and G1 (pointing) predominating. For the VM class, there were three main differences:

1. an increase in the frequency of gestures and when they were used;

2. a change in the type of gestures used; and
3. limited usage of changing *body position* (BP) when using virtual representations.

These differences are further elaborated on in the next two subsections.

***An increase in the frequency of gestures and when they were used in the VM class***

The most significant difference in VM students’ use of gestures was the increase in their frequency. In contrast to the PM class, which generally only used gestures in the Enhance: Guided Application phase, the VM class used gestures throughout all phases of the lesson. Additionally, all gesture types (other than the BP gesture) were more frequently used in the VM class compared to the PM class.

***A change in the type of gestures used across the phases for the VM class***

As evidenced in Table 5.14, VM students’ gestures appeared in the following sequence through the lesson:

1. Orientate: they began predominantly with the use of *iconic gestures* (G2);
2. Enhance: Explicit Modelling: they then proceeded to including *pointing* (G1);
3. Enhance: Guided Application: they proceeded to including *grounding gestures* (GE) and *metaphoric gestures* (G3); and
4. Synthesise: they concluded with only using *iconic gestures* (G2).

This progression is discussed further in the next subsections, where excerpts from the Orientate, Enhance: Explicit Modelling, and Enhance: Guided Application phases are presented.

***Orientate phase***

Table 5.15 presents a vignette of the transcript from the Orientate phase of Lesson 3, where a student began with a *metaphoric gesture* (G3) followed by numerous *iconic gestures* (G2).

Table 5.15

*Use of Iconic Gestures (G2) in the Orientate Phase (L3SO VM 9: Utterance 42)*

Utterance	Verbal communication	Gesture (non-verbal communication)	
42	S42 We had to um,		
	(a) um	(a) Raises hand to begin a gesture	G3
	we had to write		
	(b) forward,	(b) Points finger forward away from body	G2
	(c) back,	(c) Moves hand back towards self	G2
	(d) top, and	(d) Raises hand slightly	G2
	(e) bottom and we had to	(e) Puts hand back down	G2
	(f) turn it around so we can see what	(f) Rotates hand around and back	G2
	difference does that show.		

Utterance 42 begins with S42 using a *metaphoric gesture* (G3) of raising her hand. This motion of raising her hand appeared to trigger further thoughts. This gesture provided the teacher with an indication that S42 had an idea about the spatial concept being discussed. S42 continues by using iconic gestures to emphasise and clarify the meaning of the *special keywords* she has used in her explanation. When she used the word “forward”, in Utterance 42(b), she gestured by pointing her finger forwards. For the words “back”, “top” and “bottom”, S42 continues to use *iconic gestures* to add a visual image for these *special keywords*. In Utterance 42(f), S42 uses *iconic gestures* (G2) to create a visual image of the phrase, “turn it around” by rotating her hand around in a circle. All of these *iconic gestures* were used by S42 to create visual images to help clarify her verbal explanation. This act of clarification was a common occurrence in the VM class.

*Enhance: Explicit Modelling phase*

Table 5.16 presents a vignette from Lesson 3, which occurred when the teacher was paraphrasing the instructions and modelling the task on the iPad. The teacher asked students to give her directions on how to complete particular parts of the task in the iPad app.

Table 5.16

*Use of Iconic Gesture (G2) in the Orientate Phase (L3SO VM 9: Utterance 69)*

Utterance	Verbal communication	Gesture (non-verbal communication)	
69	S46 (a) 3 behind	(a) Holds up three fingers	G2
	(b) the ...	(b) Points to image on the iPad to show behind	G1
	(c) the 2.	(c) Points to image on the iPad, indicating the 2 blocks in the front	G1

In this example, the student used *iconic* (G2) and *pointing gestures* (G1) to add clarification to her direction.

*Enhance: Guided Application phase*

This phase continued with similar usage of these *pointing* (G1) and *iconic gestures* (G2). During the Enhance: Guided Application phase, the VM students also used *grounding gestures* (GE). An example of the use of these *grounding gestures* (GE) is provided in Table 5.17.

Table 5.17

*Use of Grounding Gestures (GE) in the Enhance: Guided Application Phase (L3SO VM 1: Utterance 145–152)*

Utterance	Verbal communication	Gesture (non-verbal communication)	
145	S37 Drag one of those over to there	Drags a yellow disc into the correct position	GE
146	S42 (a) Like this ....	(a) Drags three more yellow discs into the correct position	GE
	(b) ....	(b) Starts to drag a green disc	GE
147	S37 There	Pointing to where the green disc should go	G1
148	S42 .....	Drags the green disc into correct position	GE



149	S37		Takes over the task dragging blue discs into position	GE
150	S42	You have to make a copy.	Points to the screen	G1
151	S37	(a) .....	(a) Continues with 3 other green and blue discs	GE
		(b) That one there ...	(b) Points to a blank space	G1
		(c) is it that one or that one	(c) Points to two different coloured discs	G1
152	S42	Yeah, that one.	Points to the correct colour disc	G1

In Utterance 145, S37 has used *grounding gestures* (GE) to model how S42 is to complete the task on the iPad. S42 then uses *grounding gestures* (GE) to complete the next step in the task (Utterance 146). The purpose of this action is to clarify understanding of the spatial concept. This sequence of using *grounding gestures* (GE) to model and then clarify was repeated by students in Utterances 147 and 148.

The presentation of the grounding gestures in the above vignette took on a different appearance to its use in the PM class. In the PM class, *grounding gestures* (GE) were used by students either when they appeared not to have the language to express their thinking and therefore showed their thinking on the physical material, or when they needed to interact with the physical model to assist their spatial thinking. By contrast, *grounding gestures* (GE) in the VM class appeared when students were peer scaffolding. In these peer-scaffolding situations, the grounding gestures were used to explain students' thinking through the act of modelling the task on the iPad application.

### *Synthesise phase*

In the Synthesise phase, the gestures were very similar to those found in the Orientate phase. An example of how *iconic gestures* (G2) were used to add visual imagery to clarify the meaning of certain language is presented in Table 5.18.

Table 5.18

*Use of Iconic Gestures (G2) in the Synthesise Phase (L3SO VM 5: Utterance 184)*

Utterance	Verbal communication	Gesture (non-verbal communication)	
184 S39	Because one of the		
	(a) sections you had to do the	(a) Places both hands out in front of body to indicate a section	G2
	(b) highest number and tell you	(b) Raises right hand high above head	G2
	(c) how high.	(c) Moves hand in upwards motion like counting (indicated by levelled increments)	G3

Utterance 184(a) shows how S39 used an *iconic gesture* (G2) by indicating a part of a whole for the word “sections”. She continued, in Utterance 184(b), with her hand raised up high to emphasise the word “high”. To conclude her thinking, S39 uses a *metaphoric gesture* (G3) for the phrase “how high”. This gesture of counting in an upward motion indicated that counting would be required to assist in completing the task. This shows that S39 is accessing a deeper

level of thinking. By using a *metaphoric gesture* (G3), the student is acknowledging that ideas from another concept are needed to complete the task.

The VM students would use *iconic gestures* (G2) to explain their learnings from the lesson. It appeared that the absence of the physical material led students to use *iconic gestures* (G2) to assist the communication of their ideas

### **5.3.1.3 Summary of PM and VM students' communication**

Analysis of the PM and VM students' communication revealed that students' use of *mathematical words* and *visual mediators* have an interdependent relationship with each other. Often, students used both forms of these communicational approaches to communicate their understanding of spatial concepts. In both the PM class and the VM class, *visual mediators* were used to enhance students' *mathematical words*. However, in contrast to the PM students, VM students' use of *visual mediators* was related more to clarifying *special keywords*, rather than assisting with the initial formulation of these words. When students from the VM class were experiencing difficulties with the spatial concept, instead of using *grounding gestures* (GE) or changes to their *body position* (BP) like the PM students, they created *iconic gestures* (G2) to assist their thinking.

### **5.3.2 Students' communication of learning and its influence on teaching**

The changes and differences that occurred in students' communication of their learning in terms of both *mathematical words* and *visual mediators* changed the scaffolding applied by the teacher in the VM classroom. First, the change in VM students' sentence structure influenced teacher scaffolding. To highlight how this change eventuated, a vignette from the Orientate phase of the Symmetry lesson (L3SV) that was presented in Table 4.43 is examined, a vignette of the teacher negotiating the meaning of the word "symmetry" with students.

S29 began the discussion in Utterance 27 with a response to the question pertaining to their understanding of symmetry in the form of a simple phrase, "something the same". S35 in Utterance 29 reveals a more complex understanding of symmetry as "Something that you can fold and it will look the same on both sides". The introduction of the two ideas of "folded" and "same on both sides" expanded students' understanding of the concept to include a "mirroring" notion. This change in students' sentence structure indicated to the teacher that student learning was at a particular level, and that scaffolding could proceed to a higher cognitive level. This is evident in Utterance 33 where the teacher tried to extend students' conceptual thinking by challenging (3B) S35's idea and asking, "Are they exactly the same? Like would you draw ...

say if you drew a heart on this side with a spike coming out on one ... okay so if I drew a heart and then with a shape over here, do I draw a heart with the same thing coming out the other side?”.

Second, as VM students increased their range of special keywords, these words began to indicate the depth of students’ understanding. This resulted in two actions by the teacher: further clarification and rephrasing of these keywords, and the introduction of new keywords for students to use. An example of this change to VM students’ use of special keywords was evident in two vignettes. The first, Table 5.19, presents the teacher rephrasing a student’s response in the Orientate phase. In Utterance 33, the teacher introduced the special keyword “rotated” to extend S53’s mathematical vocabulary.

Table 5.19

*Teacher Rephrasing of Special Keywords (L3SO VM 9: Utterance 32–33)*

Utterance	Verbal communication	Gesture (non-verbal communication)	Scaffolding
32 S53	Moved the screen.		
33 T	So yep, (a) you dragged across the screen and it (b) <u>rotated</u> and (c) moved that (d) shape <b>around</b> so <b>you could see it</b> from different angles.	(a) Points to student  (b) Right hand cupped like holding a ball and rotates thumb forward (c) Rotates hand backwards (d) Rotates hand in different directions for each bold word	G1 1A (+ve feedback) 2RSC (rephrase)  G2 2RSC (rephrase)  G2 2RvC (paraphrase) G4 2RSA (context)

The second, Table 5.20, presents a vignette from the Synthesise phase of the same lesson. The student’s extension of the concept is evident through his introduction of different special keywords related to the original concept that was introduced by the teacher in the Orientate phase.

Table 5.20

*Student's Extension of Special Keywords (L3SO VM 9: Utterance 51–53)*

Utterance	Verbal communication	Gesture (non-verbal communication)	Scaffolding
51 S53	I didn’t use the [inaudible 00:05:17] thing, (a) Maybe like using <u>different degrees</u>	(a) Rotates hand around (like turning a ball in hand)	G2
53 T	Different degrees, ... so in your (a) head you are thinking about how you have to (b) turn it so many degrees? That’s really clever. So you had to turn 180 degrees. That’s really clever.	(a) Points head  (b) Mimics rotation of hand, like student’s action	G1 2RvC (paraphrase)  G2 2RSD (negotiate) 1A (+ve feedback) 2RSC (rephrase) 1A (+ve feedback)

In Utterance 51, S53 has extended on the idea of rotation, represented by the teacher's rephrasing that occurred in the Orientate phase, to a deeper level of understanding by introducing the special keyword "degrees". The student's use of a new special keyword resulted in further discussions about the concept. These later discussions included the introduction of more special keywords, such as "half turn". This change in S53's use of a more mathematical word indicated to the teacher that the student had progressed to a deeper level of understanding.

In summary, the increased implementation of language restructuring scaffolds (i.e., rephrasing: 2RsC; and negotiating meanings: 2RsD) in the Orientate phase of most virtual lessons allowed for a shared meaning for these special keywords and therefore students were engaging with these terms from the beginning of the lesson (see section 4.3.2.2, Phase 1 – Orientate). In addition, as the iPad app used particular *special keywords* in the Enhance: Explicit Modelling phase, the teacher also continued using these *special keywords* (see Table 4.45, section 4.3.2.2, Phases 2 and 3 – Enhance: Explicit Modelling and Guided Application). Finally, students' more regular use of complex sentence structures resulted in the teacher using a greater number of Level 3 scaffolding, resulting in the teacher challenging students' understanding and making links to higher levels of thinking. This relationship between students' learning and the teacher's teaching is further discussed in Chapter 6.

## 5.4 CHAPTER REVIEW

In this chapter, the different types of communication used by students when sharing their learning were analysed. Analysis of students' communication involved data related to their use of *mathematical words* and *visual mediators*. A summary of the findings from this data analysis is presented below.

### 5.4.1 Summary of student learning findings

*Finding: There was an interrelationship between students' mathematical words and use of visual mediators.*

Findings from the analysis of students' communication revealed that both constructs (*mathematical words* and *visual mediators*) are needed for the teacher to be able to interpret students' level of spatial learning. In the PM class, when students only used verbal language to discuss their spatial understandings, the teacher scaffolded students' learning by asking them to "touch" the physical material to show their thinking (see Table 4.28, section 4.3.2.1). Additionally, in the VM class, the teacher asked students to verbalise their thinking (as there was an absence of physical materials), which resulted in students using *iconic gestures* (G2) in

place of the physical material (see Table 4.42, section, 4.3.2.1). Through this process, the teacher illustrated to students that mathematical discourse includes both verbal and non-verbal forms of communication.

While this interrelationship between language and gesture was evident in both classes, there was an observed difference in the purpose behind students' use of gesture depending on the external representation used in the teaching. Gestures in the PM class appeared to act as the formulator of language, assisting students in accessing the correct language to use when discussing their spatial thinking. By contrast, gestures in the VM class appeared to act as a clarifier to the *mathematical words* used by the student (see section 5.3.1.2, A change in the type of gestures used across the phases for the VM class).

*Finding: The type of representations used influenced the mathematical words used by students to communicate their spatial understandings.*

Although, overall, students' use of *mathematical words* progressed when either form of external representation (PM or VM) was used, students in the VM class began using more complex sentence structures earlier in the lesson and continued to use more complex sentence structures throughout the lesson. Additionally, while both classes had similar trends in *special keyword* usage according to the phases of the lesson, VM students' use more than doubled in frequency compared to the PM class. This was evident in all phases of the lesson.

*Finding: The type of representations used influenced the type of gestures (i.e., visual mediators) used by students to communicate their spatial thinking.*

The results of a gesture comparison revealed that students in the VM class used a wider variety of gesture types throughout all phases of the lesson. However, the PM class used BP gestures more frequently.

*Finding: The type of representations used influenced changes to routines in students' communication.*

The sociocultural context of the classroom changed depending on the type of external representation used. The use of PM resulted in a teacher-directed learning situation, where the teacher was the provider of "expert" knowledge. Using PM appeared to foster a belief that the teacher's relationship to students was authoritative. The establishment of this relationship, therefore, influenced the social and cultural behaviours (*routines*) displayed by students. Participation in mathematical discourse appeared to be dependent on the teacher to initiate it. By contrast, when using VM, the role of the teacher changed. The use of VM appeared to allow students to assume more control of their learning. This was evident through peer scaffolding,

where students assumed the role of the provider of “expert” knowledge (MKO) (see section 5.3.2). The teacher interpreted these changes in students’ routine as a progression of their spatial thinking. Therefore, higher levels of scaffolding practices were implemented. It appeared that students were the driving force behind the change to *routines* within the VM classroom.

In Chapter 6, these findings are discussed in the light of the research literature and context of this study.

## Chapter 6: Discussion

---

### 6.1 CHAPTER OVERVIEW

In this chapter, the findings of the study are discussed and interpreted. The purpose of this study was to explore the influence of external representations (i.e., PM or VM) on students' learning of spatial thinking. The literature was presented in two themes. The first theme pertained to the role representations play in students' learning and the second theme related to the teaching and learning of students' spatial thinking from a sociocultural perspective. It was from these two themes that the research questions emerged:

1. *What influence do different external representations (e.g., PM and VM) have on young students' learning of spatial thinking?*
2. *What changes occur in the teaching and learning of spatial thinking when using different external representations (e.g., PM and VM)?*

In the next sections, findings from the study are examined and discussed according to the past findings reported in the literature review and theoretical perspectives that formed the lens through which the findings of this present study were scrutinised. The discussion begins with a focus on the first research question (section 6.2). The influence of representations on students' learning is examined using the analysis of the quantitative data and major themes presented within the literature relating to mathematical representations. The chapter continues by using Anghileri's (2006) hierarchy of scaffolding practices as a lens to scrutinise the teaching data (section 6.3) and discuss findings related to the second research question. Due to the complexities of the findings from the VM class, the lens of Sfard's (2008) commognitive approach was applied to further examine the changes in the teaching and learning process that occurred in the VM class, and the influence the use of virtual manipulatives had on students' spatial thinking (section 6.4). The chapter concludes with a review of the discussion. Figure 6.1 presents an overview of the chapter.

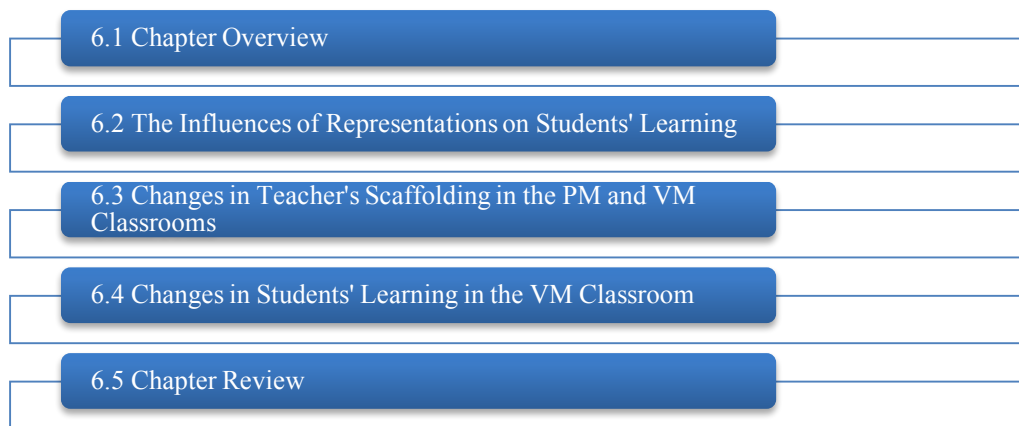

Figure 6.1. Overview of Chapter 6.

## 6.2 THE INFLUENCES OF REPRESENTATIONS ON STUDENTS' LEARNING

Analysis of the quantitative data from the spatial testing material, from the pre-test to the post-test, indicated that the use of external representations (i.e., both PM and VM) improved students' learning of spatial thinking. The Control class did not make the same statistically significant gains as the PM and VM classes (see Tables 4.13 and 4.14). Overall, the effect sizes for the VM class were larger than for the PM class, indicating that the teaching episodes had a greater effect on the VM students' learning as compared to the PM students' learning (see Tables 4.9, 4.10, 4.11 and 4.12). Furthermore, analysis of the quantitative data indicated that improvements made from the pre-test to the post-test were maintained over a six-month non-intervention period. These results not only strengthen the argument for manipulative use to enhance young students' learning of spatial thinking, but also extend these claims by concluding that these gains are maintained over time.

These results align with previous research that suggests manipulative use is beneficial to teaching and learning mathematics and yields positive results with regard to students' learning (Brown, 2007; Clements, 1999; Heddens, 1997; Highfield & Mulligan, 2007; Riconscente, 2013; Siemon et al., 2011; Sowell, 1989; Warren, 2006; Warren & Miller, 2013). Within spatial thinking, constructivist and developmental psychologist have often advocated students' use of objects within their environment to assist in the process of internalising their learning (Piaget & Inhelder, 1967). Additionally, mediation through tools (e.g., objects and artefacts) assists the progression of students' thinking from concrete to abstract ideas (Vygotsky, 1978). Even Van Hiele (1986) stressed the importance of physical manipulatives in the *directed orientation* phase of learning spatial thinking, as it allows playing and experimentation (i.e., using mathematical materials to explore topics). Furthermore, many studies based in play-based learning support



this claim (e.g., Clements & Sarama, 2014; Lewis Presser, Clements, Ginsburg, & Ertle, 2015; Wager, 2013).

The results from this study strengthen claims of other comparative studies where students who participated in interventions that used manipulatives (either PM or VM): (a) outperformed those who did not (Clements, 1999); (b) gained more understanding (Moch, 2001) or made greater mathematical progress (Hitchcock & Noonan, 2000); and (c) demonstrated higher performance in spatial ability tests (Bishop, 1973). The results also affirm the positive gains that have been attributed to the use of multiple representations, such as manipulatives, language and gestures (Ainsworth, 2006; Kaput, 1992; Santos & Trigo, 2006; Warren & Miller, 2013), and in particular the use of VM in supporting student learning (Alagic & Palenz, 2006; Hennessy et al., 2001; Lowrie, Jorgenson, & Logan, 2013; Mayer, 2002; Moyer-Packenham & Suh, 2011; Stylianou et al., 2005; Suh et al., 2005; Zbiek et al., 2007). In addition, the study further highlights the effectiveness of embodied actions (e.g., iconic gestures, changes in body position, metaphoric gestures) as contributors to students' spatial thinking (Alibali & Nathan, 2012; Battista, 2008; Dempsey, 2005; Wilson, 2002).

The results of this study also contribute to the debate about the staging of physical and virtual manipulatives with regard to student learning. The result that both classes made similar gains on the post and post-post-tests raises questions about previous literature stating that students' learning progresses through three levels of engagement with external representations (Bruner, 1966). These three levels are (a) manipulations (enactive representations); (b) perceptual organisation and imagery (iconic representations); and (c) use of language and symbolic thought (symbolic representations) (Bruner, 1966; Piaget & Inhelder, 1967). Aligning with this stance are the results of a more recent study by Hunt et al. (2011) that recommended using physical manipulatives prior to virtual manipulatives as a means of facilitating progression to abstraction. The results of this present study question this progression. The VM class did not interact with physical manipulatives during the teaching episodes, and did not need physical manipulatives to make similar gains in their learning. It could, therefore, be hypothesised that this progression from physical to virtual may not be necessary; however, such claims would warrant further investigation. In addition, this study challenges the claim that the progression should occur from physical materials to virtual materials because the former materials are "multisensory" and thus lead to more detailed memory structures, and the latter materials are "bisensory" and facilitate the process of mathematising and abstraction (Proctor et al., 2002, p. 3). The results of this present study also raise the question of whether the use of

physical manipulatives is a necessary step in the development of spatial thinking. Can young students' simply progress to the virtual? Or should the simultaneous use of both occur?

While this study did not explore the use of one manipulative type and subsequent use of another, or the use of both simultaneously, some studies have suggested that all three levels of representations (enactive, iconic and symbolic) should occur in parallel rather than sequentially (e.g., Goldin & Shteingold, 2001; Kaput, 1992; Lowrie, Logan, & Scriven, 2012) and that simultaneous use of PM and VM offers a better connection between concrete and abstract ideas (Clements, 1999; Thompson & Thompson, 1990). Future studies into the combined use of PM and VM, or the differences in different sequences of manipulative types, would be beneficial within the context of students' learning in spatial thinking.

The results of this study concur with, and extend, the notion that the use of PM appears to help students to form connections between their internal and external representations of spatial concepts (Basson et al., 2006; Bills & Gray, 1999; Goldin & Kaput, 1996; Pape & Tchoshanov, 2001). This study extends on this finding, as not only did PM improve students' ability to visualise and mentally manipulate spatial objects, as evidenced by the results on the visualisation and orientations tests (an indication of progressing their spatial thinking towards abstraction), but also the use of VM achieved similar results. Furthermore, the results of the NAPLAN-like tests (NO, NV1, and NV2) suggest that use of PM and VM assisted students to transfer between 2D and 3D representations and link physical representations to abstract ideas, two difficulties that past research has revealed (e.g., Battista & Clements, 1996; Clements, 1999; Ho & Logan, 2013; Toptas et al., 2012). While this study did not purposely examine the influence of external representations on students' internal representations, it points to a similar opinion formed from Lowrie's (2002b) study that further investigation into the importance of transference between representations is more beneficial than further examining if one manipulative is better than another.

Overall, while there was no statistically significant difference between the PM and VM scores on the spatial testing material, the effect sizes were greater in the VM class. This could possibly indicate that given a longer time period and with prolonged use of PM and VM, potentially greater differences could occur, and thus concur with Suh's (2005) study, where thirty-six third-grade students (aged 8–9 years) using VM to complete fraction and algebra tasks outperformed students using PM. To fully explore the effect sizes in this present study, an analysis of the qualitative data was conducted. This analysis focused on scrutinising the changes that occurred in the teaching and learning within the PM and VM classes. The next section

begins by discussing the differences that occurred in the teaching according to the type of manipulative used.

### **6.3 CHANGES IN TEACHER'S SCAFFOLDING IN THE PM AND VM CLASSROOMS**

Previous research on teaching spatial thinking acknowledges the importance of scaffolding within the context of using PM such as pattern blocks and 3D objects (Anghileri, 1995, 2006; Anghileri & Baron, 1998; Bishop, 1980; Huttenlocher, Levine, & Vevea, 1998; Newcombe, 2010; Van Hiele, 1986). This study expands on this scaffolding literature by including the influence that VM had on the teacher's scaffolding practices.

A finding from this study that is discussed in this section is how different types of external representation (PM or VM) influenced the types of scaffolding practices used by the teacher. The section consists of three subsections. First, a brief overview of Anghileri's hierarchy is represented. Second, the scaffolding practices implemented in the PM class are discussed in relation to Anghileri's hierarchy. Gaps in the hierarchy as well as similarities and differences between Van Hiele's model and Anghileri's hierarchy are discussed, and a new theoretical framework for scaffolding with PM is developed and presented. Finally, the scaffolding practices used in the VM classes are discussed.

#### **6.3.1 An overview of Anghileri's hierarchy of scaffolding practices**

Anghileri's hierarchy of scaffolding practices provides teachers with three levels of scaffolding practices to advance students' spatial thinking. Figure 6.2 presents Anghileri's hierarchy of scaffolding practices for Levels 1, 2 and 3.

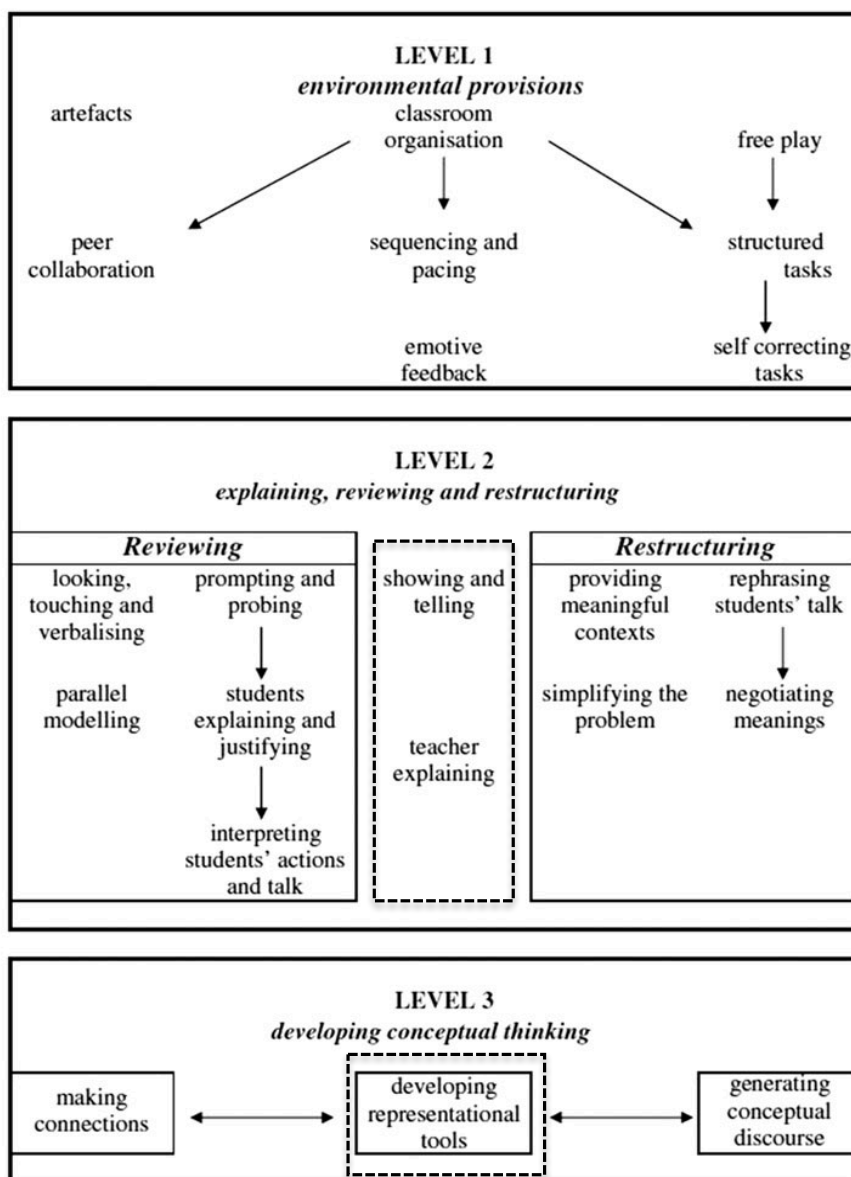

Figure 6.2. Anghileri's (2006) hierarchy of scaffolding practices.

Briefly, Level 1 encapsulates environmental factors (e.g., classroom organisation, design of the lesson, the incorporation of tools, use of peer collaboration, and emotive feedback). In this study, only the interactive aspects of Level 1 scaffolding practices were included in the analysis of the teacher's scaffolds. These comprised the use of emotive feedback and peer collaboration. Level 2 is concerned with teachers "explaining, reviewing and restructuring" mathematical concepts. Level 3 focuses on how teachers provide support in the development of students' conceptual understandings of mathematics. The central element (indicated by the dotted box) is what Anghileri considers are the most commonly seen scaffolding practices within mathematics classroom teaching. The scaffolding practices displayed peripherally in the framework are further supporting strategies that occur in effective classrooms. Although not explicitly stated by Anghileri, these peripheral scaffolding practices require students to engage

in higher levels of thinking. Anghileri also suggests that “the establishment of practices at different levels reflects not only the progressive (and often circular) supporting strategies that can be used, ..., but also the way effective interactions may be developed” (Anghileri, 2006, p. 38). In other words, although the levels are progressive in nature, each level may need to be cycled back through in order to progress students’ thinking (see section 4.3.2.1).

### 6.3.2 Scaffolding practices in the PM class

This section begins with a very brief description of the findings from Chapter 4 regarding the scaffolding practices observed in the PM class. Figure 6.3 is a re-presentation of Figure 4.2, a summary of the findings presented in Chapter 4.

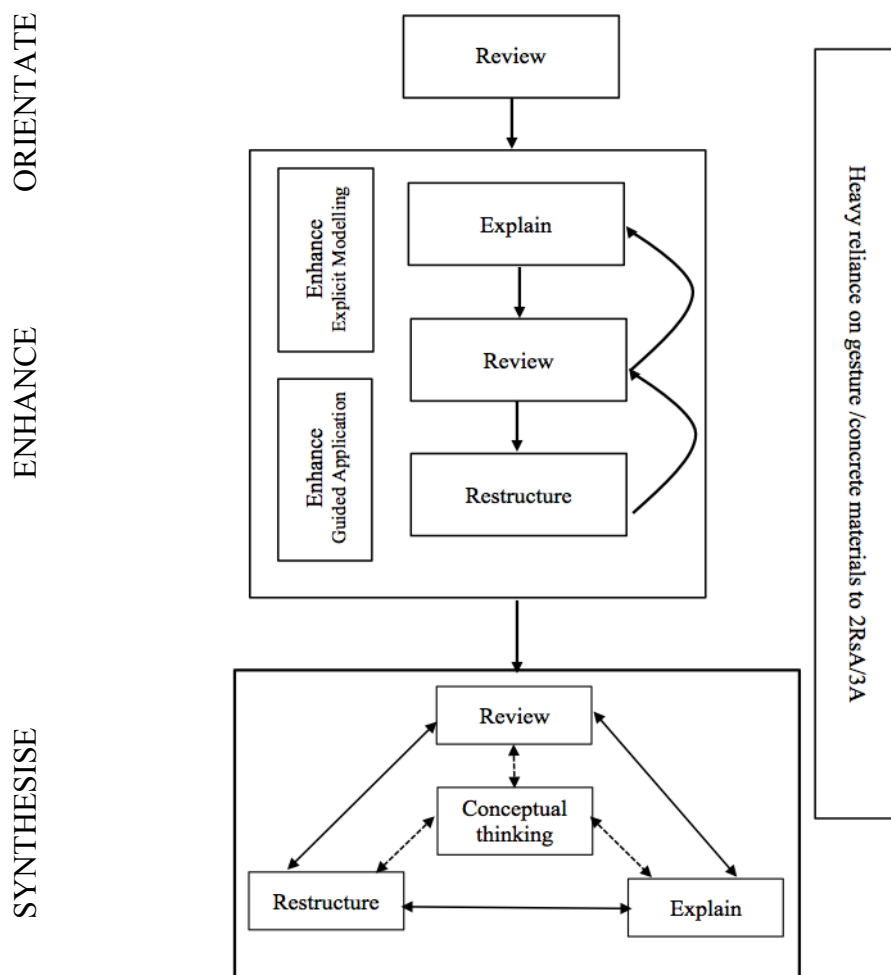

Figure 6.3. The findings of the scaffolding in the PM class.

The sequence of scaffolds that occurred in the PM classroom, in general, aligned with Anghileri’s theoretical framework (see Figure 6.2). The teacher followed a linear format where scaffolding levels were implemented sequentially. In other words, Level 2 scaffolding practices

were applied in the early phases of the lesson (i.e., Orientate and Enhance phases) and Level 3 scaffolding practices, developing conceptual thinking, were utilised later in the Synthesise phase.

### 6.3.2.1 Adding to Anghileri's hierarchy of scaffolding practices

#### *Levels within levels*

Extending Anghileri's hierarchy, the results of this research indicated that within each level there was a subsequent hierarchical order (i.e., an additional nested hierarchy). For example, examination of Anghileri's representation of Level 2 scaffolding practices (see Figure 6.2) suggests that the centrally located scaffolding practices of "showing and telling" or "teacher explaining" are the most common practices applied in the mathematics classroom. Thus, they are not only the starting point for most teaching, but are also the points of common return throughout this phase of the lesson. This idea, represented in Anghileri's hierarchy, suggests a predominant model of knowledge transition as the teacher retains control and structure of conversations. Other than this, Anghileri's hierarchy provides no insights into the interrelatedness between the three constructs within the Level 2 scaffolds (i.e., explaining, reviewing and restructuring). In this study, Level 2 scaffolding practices were applied in a cyclical, sequential progression (see Appendix I). How the Level 2 scaffolding practices were progressively applied and then cycled back through when misconceptions occurred is presented in Figure 6.4. This subsequent hierarchy of Level 2 scaffolding practices was most evident in the Enhance phase of the PM lessons (see section 4.3.2.1).

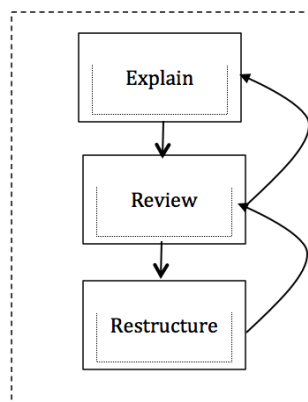

Figure 6.4. The hierarchical structure within Anghileri's Level 2 scaffolding structure.

In this study, the subsequent hierarchy of Anghileri's Level 2 scaffolding practices began with *explaining*, moved to *reviewing* structures, and then used *restructuring* structures when students' learning needed to be modified. If students continued to struggle with a concept and needed further assistance, the teacher cycled back through the scaffolding practices; that is, she moved from *restructuring*, back to *reviewing*, and if required restated using *explaining* again

(see section 4.3.2.1, Scaffolding practices used in Phase 3 – Enhance: Guided Application). Thus, these three scaffolding practices did not occur randomly, but were interdependent with a purposeful movement.

Additionally, a subsequent hierarchy was apparent within the Level 3 scaffolding practices. Evident in the Synthesise phase, this hierarchy within Level 3 began with Anghileri's central theme of *developing representational tools* (3A), continued with *making connections* (3B) by challenging and linking students' conceptual ideas, and was followed by *generating conceptual discourse* (3C). The application of Level 3 scaffolding practices, in this order, was continually supported by Level 2 scaffolding practices (see Appendix I). Therefore, within each of Anghileri's hierarchical levels (i.e., Level 2 and Level 3), subsequent hierarchical levels were observed.

Furthermore, the application of these scaffolding practices in these hierarchical structures suggests that each subsequent scaffold requires more complex levels of thinking from students. Thus, while Anghileri's hierarchy was “developed to support the practitioner in reflection and analysis of actual classroom practices” (2006, p. 50), the results of this research indicate the usefulness of this hierarchy to assist teachers in planning, scaffolding, and progressing students' spatial thinking.

#### ***Levels occurring simultaneously***

Another extension that was not evident in Anghileri's hierarchy was the use of two scaffolding practices simultaneously. The two scaffolding practices that often occurred simultaneously were the *explaining* (2Ex) and *providing meaningful contexts* (2RsA) scaffolds. The first scaffold (*explaining*) contained a verbal component that centred around the use of language, while the second (*providing meaningful contexts*) contained a visual component that focused on the teacher's use of gestures and interactions with the PM (see Table 4.31, section 4.3.2.1, and Appendix I). These two components are both forms of external representations, which many researchers acknowledge as important to mathematics learning (Clements, 1999; Cuoco & Curcio, 2001; Goldin, 2003; Goldin & Shteingold, 2001; Heritage & Niemi, 2006; Kilpatrick et al., 2001; Warren & Miller, 2013).

The simultaneous use of two scaffolds (i.e., *explaining* and *providing meaningful contexts*) aligns with literature related to dual coding theories (Mayer & Anderson, 1991; Mayer & Moreno, 1998; Mayer, 2002; Mayer & Sims, 1994; Paivio, 1986; Sinclair & Yerushalmy, 2016), which states that “people learn more deeply from words and pictures than from words alone” (Mayer, 2005, p. 47). It is suggested that dual coding overcomes the limitations of human working memory and promotes higher cognitive processes (Sweller, 1999), decreases cognitive

load (Mayer, 2005) and thus increases working memory (e.g., Farah et al., 1988; Rasmussen & Bisanz, 2005). Therefore, the findings of this present study indicate that the use of gestures in communication, and learning, cannot be ignored. However, whether they are integral to the verbal channel or the pictorial channel (or a separate channel) requires further research.

The findings of this study also indicate that PM themselves offered limited structure and guidance as a pictorial/visual representation and that *explaining* (2Ex) and *providing meaningful contexts* (2RsA) were required to assist the development of students' spatial thinking. The simultaneous use of two scaffolds was a necessity in promoting higher levels of scaffolding practices. Presented in Figure 6.5 is a segment of scaffolding that occurred in the Enhance: Explicit Modelling phase of the third lesson highlighting simultaneously occurring scaffolds and subsequent higher-level scaffolds. A full account of the scaffolding practices implemented throughout the whole phase is presented in Appendix I.

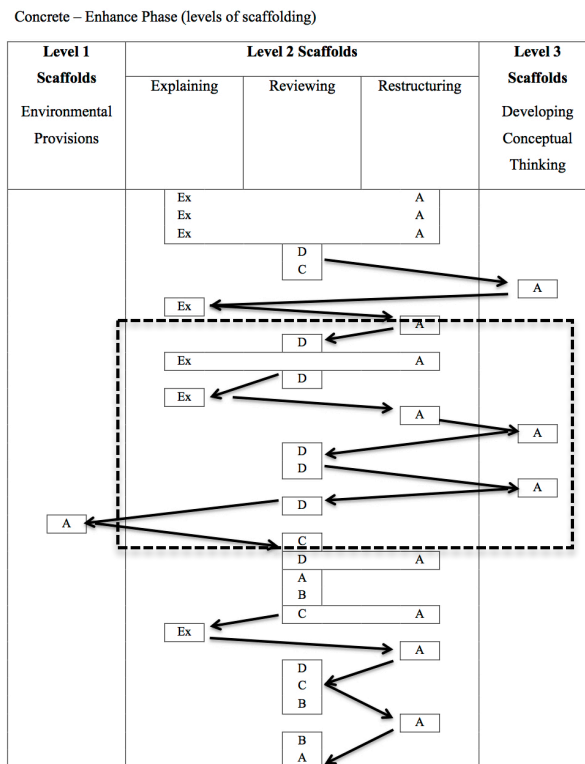

Figure 6.5. A section of scaffolding practices in the Enhance: Explicit Modelling phase highlighting simultaneously occurring scaffolds and subsequent higher-level scaffolds.

In the beginning of the Enhance: Explicit Modelling phase, the teacher used simultaneous scaffolding practices (i.e., *explaining* and *providing meaningful contexts*) to model and explain the spatial task of describing a model made out of Lego bricks from different points of view. As indicated by the dotted rectangle in Figure 6.5, the use of simultaneous scaffolds involved the verbal scaffolding practice of *explaining* (Ex) and the visual scaffolding practice of using gestures to *create a meaningful context* (Level 2A). The introduction of simultaneous scaffolds



provided opportunity to extend scaffolding to higher levels. In the above example, first, a *restructuring* scaffold (2RsA) was implemented, followed by the Level 3 scaffold of *developing representational tools* (3A).

### ***Reviewing scaffolding occurring at the beginning of lessons***

Another aspect missing from Anghileri's hierarchy was the importance of reviewing students' prior learning before new learning was introduced. Findings of this present study indicated that Level 2 *reviewing* scaffolds were used at the beginning of lessons, in the Orientate phase (see Table 4.28 section 4.3.2.1). The *reviewing* scaffolding practices used included: *looking, touching* and *verbalising* (2RvA), *prompting and probing questions* (2RvD) and *paraphrasing* or *interpreting students' actions and talk* (2RvC). Occasional use of a *restructuring* scaffold to *negotiate the meaning* (2RsD) of the language used by students (see Table 4.29 section 4.3.2.1) also occurred. The teacher utilised these *reviewing* scaffolds to establish students' prior knowledge and previous experiences related to the spatial concept. Assumptions could be made from Anghileri's model that consideration of this important aspect of scaffolding existed within the *environmental provisions* found in Level 1. However, it is not explicitly stated.

### ***6.3.2.2 Comparing Anghileri and Van Hiele's theoretical frameworks and the findings from the PM class***

While Van Hiele's model of development of geometric thought postulated that students' progression to the next level is the result of instruction, based on the progression through five phases of learning, findings from this study suggest that these five phases in fact underpin how spatial thinking is taught within a lesson structure.

Although Van Hiele's model presents a process illustrating how progression of student spatial thinking could occur from instruction based on a progression of learning phases, it lacks the practical implications of how teachers support students' spatial thinking within each phase. In contrast, Anghileri's hierarchy provides practical, levelled scaffolding practices that assist students' thinking by progressing to deeper levels of conceptual support. However, Anghileri's hierarchy lacks the sequential organisation of how these scaffolding practices could be applied through the progression of the lesson. The results from this study indicate a need to combine the theoretical (Van Hiele's model) with the practical (Anghileri's hierarchy), as both contribute to an understanding of a teaching process that has the possibility to progress students' spatial thinking.

### ***6.3.2.3 A new theoretical framework for scaffolding students' spatial thinking with PM***

The findings of this study build on Anghileri's hierarchy to incorporate Van Hiele's phases of learning to create a framework for scaffolding students' spatial thinking when using PM. This new model uses Van Hiele's phases of learning to form the organisational structure for the phases of teaching (see section 3.5.2.1). Within each phase, Anghileri's scaffolding practices provide further insights into the scaffolding processes that assist students to move from phase to phase and develop deeper levels of conceptual thinking. Figure 6.6 presents this new model of scaffolding practices using PM.

The model shows the four phases of learning used in this study and how these correlate to Van Hiele's phases. The first phase, Orientate, stresses the importance of *reviewing* students' prior understanding and experiences. The next phase, Enhance, is divided into two sections: Explicit Modelling and Guided Application. Explicit Modelling is the phase where the teacher is explaining the spatial concept to students. This includes modelling with PM. The Guided Application phase is where students verbalise their learning and actively participate in spatial tasks related to the concept. As this phase is where students' ideas are consolidated or modified, more effective scaffolding practices of *reviewing* and *restructuring* occur. The entire Enhance phase occurs in a cyclical pattern as students' spatial thinking is developed. Finally, the Synthesise phase is supported through the use of scaffolding practices that promote the development of conceptual thinking, in addition to all previously used scaffolding practices. The left side of the model depicts that Level 1 scaffolding practices of providing *emotive feedback* (1A) are required throughout the entire lesson. The right side illustrates the importance of the use of PM to promote students' spatial thinking throughout all phases of the lesson.

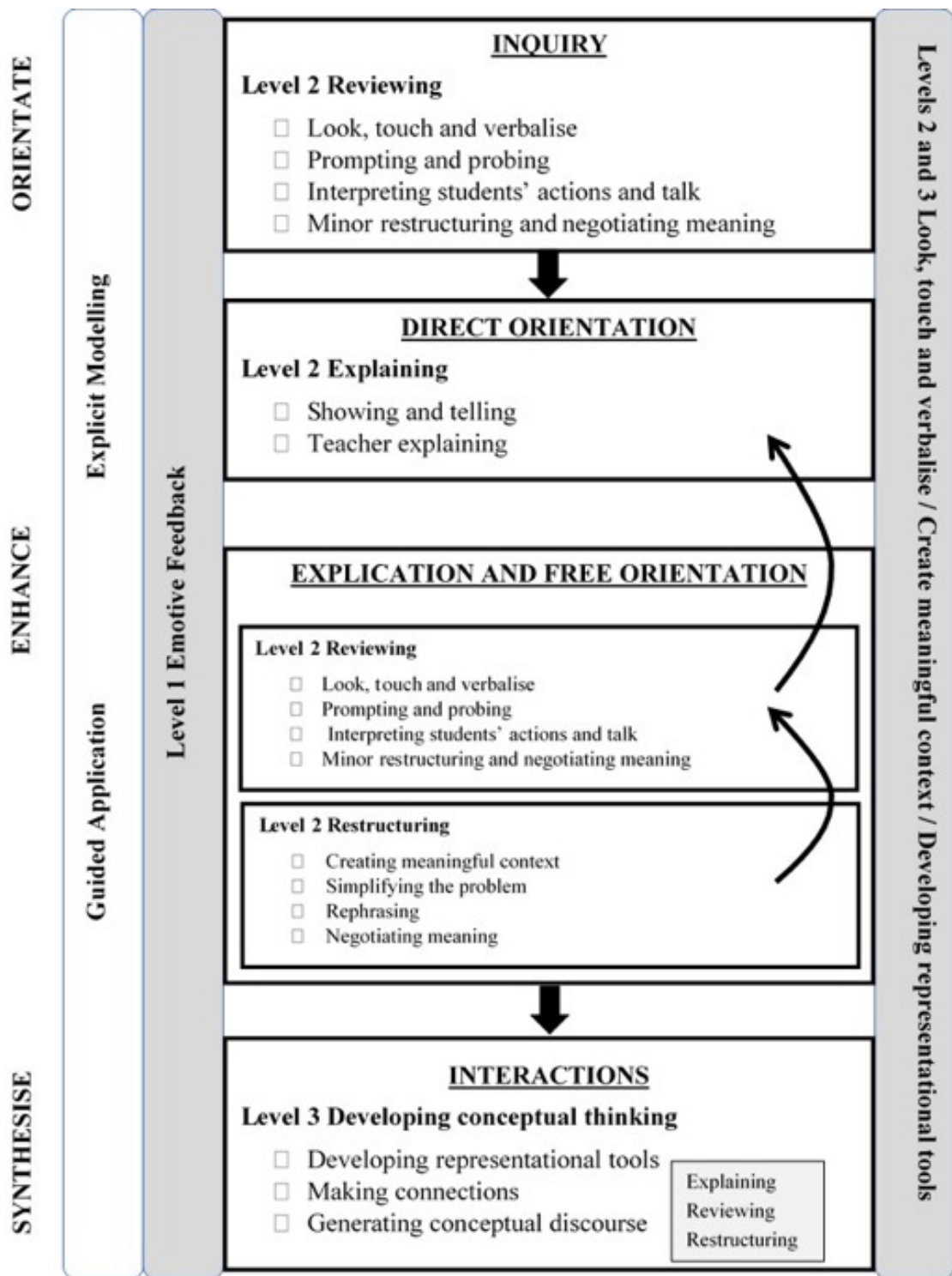
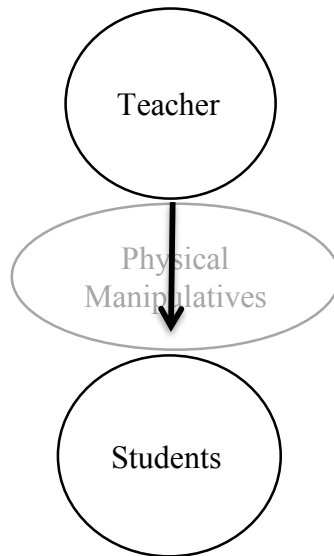

Figure 6.6. A new model of extending Anghileri's scaffolding practices to include Van Hiele's Phases of Learning when using PM.

The findings pertaining to the scaffolding practice that occurred in the PM class indicate that the teacher–learner agreement (Sfard, 2008) was very much in the control of the teacher. Presented in Figure 6.7 is a diagram representing the interactions between the teacher and the students. Within the PM class, the teacher–learner agreement was mainly teacher led, where the teacher was in control of students' interactions with the PM and the direction of their learning.

### Teacher–Learner Agreement



*Figure 6.7.* The teacher–learner agreement within the PM class.

### 6.3.3 Anghileri’s theoretical framework and the VM classroom

Analysis of the scaffolding practices implemented in the VM class revealed that the scaffolding practices utilised do not directly align with Anghileri’s hierarchy (see Figure 6.2). Figure 6.8 is a re-presentation of Figure 4.7, the findings of the scaffolding practices implemented in the VM class.

Two differences were noted between Anghileri’s hierarchy and the findings from the scaffolding practices implemented in the VM class. First, the scaffolding practices implemented in the VM class were not sequential as suggested in Anghileri’s hierarchy. The teacher did not follow a sequential sequence of only implementing lower level scaffolding practices in the Orientate phase of the lesson. All three levels of scaffolding practices were observed within the Orientate phase. Second, the VM devices used (i.e., the iPad apps) and the students themselves (evident through peer scaffolding) became involved in the scaffolding practices.

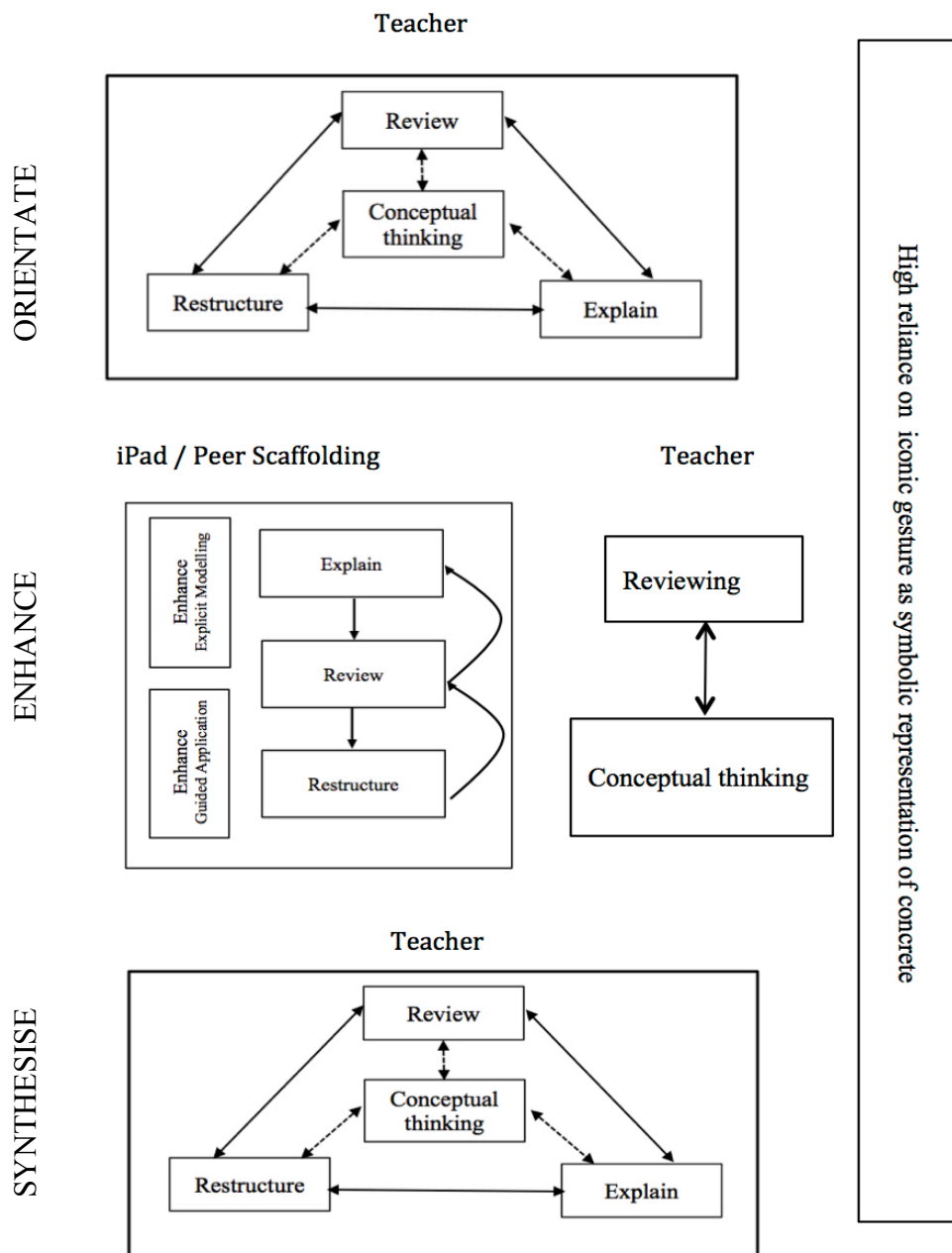

Figure 6.8. The findings of scaffolding practices implemented in the VM class.

When comparing Figure 6.3 (the scaffolding practices used in the PM class) with Figure 6.8 (the scaffolding practices used in the VM class) and Anghileri's hierarchy, several differences are evident. First, Level 3 scaffolding practices occurred in the Orientate phase of the lesson. It appeared that students drove this introduction. Unlike the PM class, these students felt able to communicate (i.e., explain and justify) the revision of their previous learning. This resulted in the teacher being provided with greater opportunities to use Level 3 scaffolds (especially, *making connections* scaffolding practices which challenged or linked students' conceptual thinking) to deepen students' ideas in the early stages of the lesson (see Table 4.37 and Table 4.38, section 4.3.2.2). It also provided greater opportunities for the teacher to

restructure students' ideas (Level 2 scaffold) as they shared (or communicated) their misconceptions (see Table 4.39, section 4.3.2.2). At this juncture, the teacher tended to add more *explaining* scaffolds to reiterate how students' ideas needed to be restructured (see Table 4.40, section 4.3.2.2). Therefore, as a result of Level 3 scaffolding practices being introduced, the use of Level 2 scaffolding practices of *restructuring* and *explaining* in the VM class also increased in the Orientate phase. Presented in Figure 6.9 is a visual, comparative representation of the scaffolding practices implemented in the Orientate phase of the PM and VM classes.

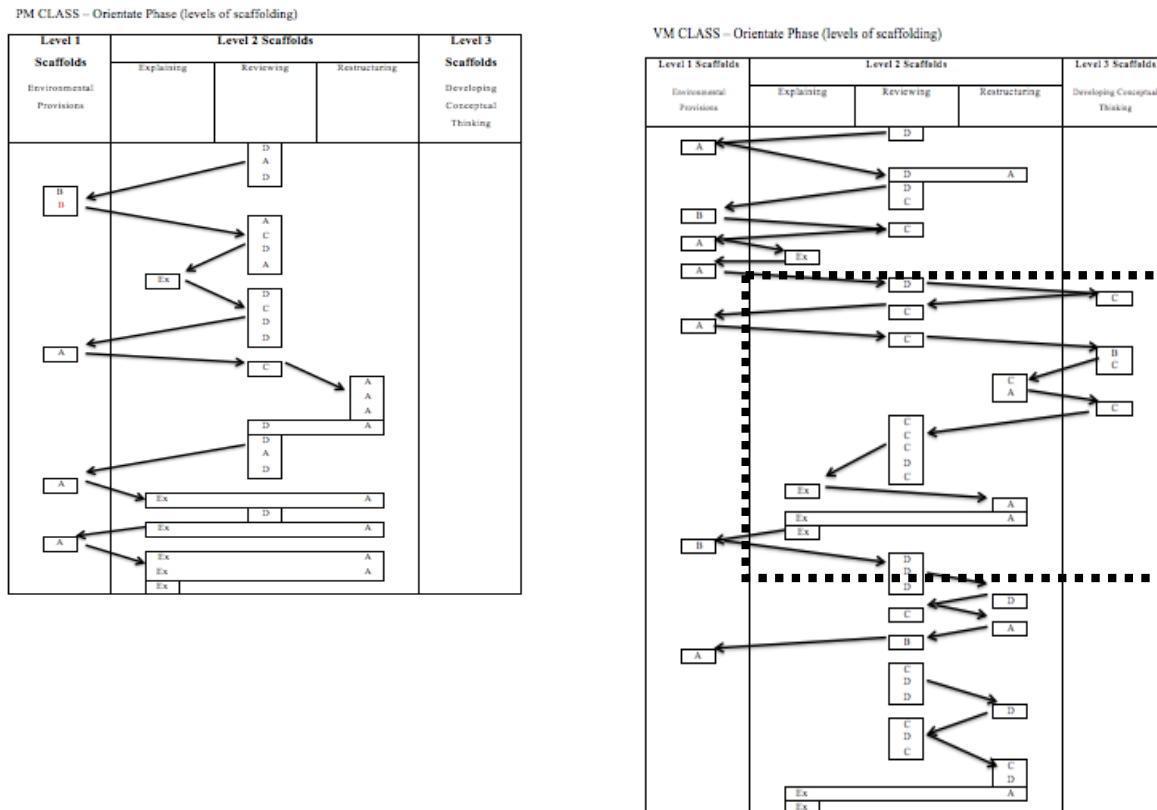

Figure 6.9. Comparing the scaffolding in the Orientate phase of the PM and VM classes.

The dotted box overlaid on the scaffolding practices implemented in the Orientate phase of the VM class illustrates how the incorporation of Level 3 scaffolding practices resulted in an increase in the occurrences of *restructuring*, progressing to more *reviewing*, and finally resulting in more *explaining* scaffolds.

Second, unlike Anghileri's hierarchy of scaffolding practices, these cycles of learning continued to occur in the Enhance and Synthesise phases (see Appendix I). Third, in the VM class, the Synthesise phase appeared to revert back to a *reviewing* of students' learning rather than a phase of *developing conceptual thinking* as was previously revealed in the PM class findings. Therefore, in contrast to the PM class (and in Anghileri's hierarchy) where the teacher provided higher-level scaffolds predominantly in the final phase of the lesson, in the VM class these higher-level scaffolds occurred at multiple times, giving students the opportunity to progress their

thinking to higher cognitive levels earlier in and throughout the lesson phases. As a result of these changes, the teaching process in the VM class became an organic, complex web of scaffolding practices, which appeared to be predominantly driven by students.

Overall, instead of the whole lesson being a progression through sequential phases of learning and scaffolding (as suggested in Van Hiele's model and Anghileri's hierarchy), the entire phases of learning cycle was repeated several times over the course of the lesson. As a result of these cycles of learning (see Figure 6.9), the use of VM appeared to allow conceptual thinking to be scaffolded earlier in the lesson sequence, resulting in more in-depth mathematical discourse occurring throughout the lesson. In addition, with the introduction of student involvement in the scaffolding of students' learning (peer scaffolding), the types of scaffolds the teacher used were influenced (see section 4.3.2.2, Phase 1 – Orientate, Students becoming active engagers in the scaffolding process). Therefore, to fully understand the changes that occurred in the teacher's scaffolding practices in the VM class, the changes in VM students' learning need to be examined as the students' learning influenced the teacher's scaffolding.

Sfard's commognitive approach (2008) was used to analyse the changes in students' mathematical learning by examining changes in their discourse. Sfard's approach extends on Vygotsky's sociocultural theory by acknowledging the didactic dialogue that occurred and including analysis of tacit and non-verbal forms of communication. Therefore, Sfard's approach broadens the lens of sociocultural theory. Sfard's commognitive lens allowed for the links between scaffolding (or "mediation" as Sfard calls it), and learning to be thoroughly scrutinised.

## **6.4 CHANGES IN STUDENTS' LEARNING IN THE VM CLASSROOM**

This section examines VM students' learning by exploring the changes that occurred in communication. In the first subsection, this discussion uses three of Sfard's (2008) characteristics of communication (i.e., *mathematical words*, *visual mediators* and *routines*) to thoroughly examine VM students' learning as compared to the PM class. In the final subsection related to *routines*, a discussion ensues with regard to the teacher-learner agreement and how these changes in students' communication had an influence on the teacher and the teaching of spatial thinking.

### **6.4.1 Student learning in the VM classroom**

Briefly, the basic tenets of Sfard's commognitive approach suggest that through observable changes in students' communication, student learning can be analysed. Analysis of mathematical discourse, for this study, involved the three characteristics of *mathematical words*, *visual mediators* and *routines*. As *mathematical words* (i.e., students' sentence structure

and use of *special keywords*) and *visual mediators* (i.e., the manipulation of external representations or visible gestures used by students) are considered, to some extent, the starting point to understanding discursive routines found in the VM classroom, the first two subsections examine students' learning by delineating the changes in students' communication related to these two characteristics (*mathematical words* and *visual mediators*). The third subsection continues with a discussion on the interrelatedness of *mathematical words* and *visual mediators* and how “commognitive conflicts” (and discovery of misconceptions) are vital to the teaching process and an essential starting place in developing students' conceptual learning. The section finishes with discussion pertaining to the changes that occurred in VM students' *routines* and the influence this had on teaching.

#### **6.4.1.1 Changes in students' mathematical words examined through utterances**

For the purposes of this study, Sfard's characteristic of *mathematical words* was examined according to two components: the structure of students' sentences; and students' use of *special keywords* (i.e., technical mathematical vocabulary). The findings indicate that using VM as compared to PM resulted in (a) increased complexity of students' sentence structure in earlier phases of the lesson sequence (see Figure 5.7, section 5.3.1.1); and (b) increased variety and frequency of special keywords (see Table 5.12, section 5.3.1.1). Both of these changes indicated that the communication of VM students was more sophisticated than that of the PM students. According to Sfard's theory, changes in students' *mathematical words* highlights changes in their mathematical learning. As a result of students' increased communication, comprising more complex forms of mathematical words, the teacher was provided with greater opportunities to assess VM students' mathematical learning as compared to the PM students. Detailed discussion of VM students' changes in *mathematical words* is presented in this subsection.

The first change in VM students' *mathematical words* related to the increased complexity of sentence structures used. Sfard's commognitive approach suggests that changes in students' sentence structure indicate changes in their conceptual understanding (Sfard, 2008, 2009). The results from this study align with this trend. Adding to Sfard's approach are the findings of this study indicating that these changes in students' communication also played a role in the teacher's implementation of higher levels of scaffolding. Thus, there appears to be a strong link between the complexity of students' communication and the levels of scaffolds used by the teacher. This point is further illuminated in the next section.

In an excerpt from the symmetry lesson (see Table 4.43), a change occurred in students' utterances when describing the definition of the term “symmetry”. S29 began (in Utterance 27)



with the simple sentence, “It means something the same.” In Utterance 29, communication about symmetry changed with S35 using the complex sentence, “Something that you can fold and it will look the same on both sides.” The sentence structure used by the VM students had changed from a simple sentence to a complex sentence. This change in students’ communication indicated a more complex understanding of symmetry (Sfard, 2008). The concept was expanded from being “the same” to include a “mirroring” aspect to the concept. A change in students’ use of sentence structure evidenced students’ ability to internalise the learning and relate the concept back to their own thoughts. At this early stage of the lesson, the teacher had not introduced the concept of mirroring. Thus, in this instance, this change indicated to the teacher that VM students were ready to extend their understanding of the symmetry concept to include a notion of “flipped”. As a result, the teacher implemented a higher level of scaffolding (3B – *making connections by challenging*) to extend students’ learning to deeper cognitive levels (see Utterance 33 in Table 4.43). Thus, students’ use of more complex forms of communication (e.g., dense noun phrases, use of circumstances and complex sentences) served as an indicator to the teacher to extend her scaffolding practices to Level 3. In addition, a consequence of VM students using complex sentences in earlier phases of the lesson (see Figure 5.7, section 5.3.1.1) was the introduction of Level 3 scaffolds earlier in the VM lesson as compared to the PM lesson. It is conjectured that this change to Level 3 scaffolds is contingent on the teacher’s depth of pedagogical knowledge, knowledge that has clearly been shown to affect student learning in mathematics (Hill et al., 2005).

The changes in the VM students’ sentence structures also led to aspects of *objectification*. Through Sfard’s reification theory (1991), the development of concepts begins as a process (action) and moves towards a structural idea (object) (see section 2.7.2). An example of this link is further evidenced in the symmetry lesson (see Table 5.19 and section 5.3.2). VM students’ ideas about symmetry had developed from the action of “flip” to include the properties of “flip” as being that of reflected (e.g., a student’s interpretation of symmetry as being “Something that you can fold and it will look the same on both sides”). At this point the teacher responded by introducing the terms “turn” and “rotate”, an example of the teacher drawing on her own subject matter knowledge (Shulman, 1986). On fruition of this process (the teacher–student interchange), the concept of symmetry became a structure or object in its own right. Thus, it is inferred that the process of “flipping” has been objectified and become part of the technical classification as “symmetry”.

The second change in VM students’ *mathematical words* related to their use of *special keywords* (the technical language of mathematics). Many linguistic researchers acknowledge that

mathematics learning involves a progression from “informal, everyday” words to “formal, mathematical” words (e.g., Barwell, 2016; Halliday, 1978; Schleppegrell, 2007; Vygotsky, 1978). Changes in technical language also play an important role within Van Hiele’s (1986) developmental model for geometric thought. The ensuing discussion of the results of this study draws on the Sinclair and Moss (2012) communication framework for geometrical learning. Briefly, this framework comprises three levels of discourse: discourse of elementary discursive objects (identification based purely on visual characteristics); discourse of concrete discursive objects (use of different special keywords grouped under one name); and discourse of abstract objects. The movement through levels is dependent upon students’ capability of identifying the “sameness” between the mathematical words they use (Sinclair & Moss, 2012).

Within this study, many students’ discourse (both PM and VM) was situated within the level of elementary discursive objects. However, the VM students’ use of *special keywords* (see Appendix R and see Table 5.12, section 5.3.1.1) entailing movement from communicating about spatial orientation concepts using purely visual descriptors (e.g., “front”, “top”, or “bottom”) to communicating using more general terms relating to these orientations (e.g., “position”, “direction”), showed that these students had moved to the second level of geometric discourse, *discourse of concrete discursive objects* (a counterpart to Van Hiele’s Level 2). Students had begun to apply principles of *saming* by communicating about spatial orientation in terms such as “position” or “direction”. This change in VM students’ discourse indicated growth in their understanding of the concept (Sfard, 2001; Sinclair & Moss, 2012). Their use of informal terms had been replaced by more formal or mathematical terms. Sinclair and Moss (2012) conjectured from their study that the use of dynamic geometry environments (DGEs) sped up this process. While the unique features of the virtual manipulative (i.e., the iPad apps) appeared to be a contributing factor to the VM students’ progression to higher levels of geometric discourse (discussed in section 6.3.2.1), the role of the teacher in scaffolding students’ progression cannot be overlooked. It was through the observable changes in VM students’ use of different *special keywords* that their learning levels were noted. This evidence provided the teacher with the opportunity to draw on her pedagogical and subject matter knowledge to extend students’ conceptual thinking to deeper levels through the implementation of higher scaffolding levels (as evidenced in the preceding paragraphs). This entailed students’ moving away from the visual mediator (i.e., the iPad representation) to participating in a more abstract, purely linguistic domain of mathematical discourse.

Finally, changes in the VM students’ use of *special keywords* (see Table 5.20, section 5.3.2) evidenced Sfard’s understanding of the process of *individualisation*, which is similar to

Vygotsky's *internalisation*. In the Orientate phase, the teacher had used rephrasing to engage a student in the collaborative practice of using specific *special keywords* to discuss the spatial orientation concept (e.g., in Utterance 53 in Table 5.19, "So yep, you dragged across the screen and it rotated and moved that shape around so you could see it from different angles"). Later in the same lesson, the student's use of more advanced *special keywords* (e.g., Utterance 31 in Table 5.20, "maybe like using different degrees"), illustrated that *individualisation* had occurred as the student had taken up the tools (i.e., the language) previously offered in the teacher's scaffolding and applied it in his own unique way (i.e., relating angle to degrees). This process of *appropriation* illustrated that *individualisation* had occurred. The student had taken on the teacher's "tradition of thought" (Walshaw, 2016, p. 18) that different spatial orientations could be referred to as different rotated positions observed from different angles, and extended this idea by viewing rotation in terms of specific number of degrees of rotation (or degrees of an angle). In other words, the student had taken up the tool, applied a "tradition of thought", and extended on this thought by offering a critical reflection of that tradition. Thus, the level of communication between participants (be that teacher-peer or peer-peer) is an important contributing factor to the *individualisation* process. The communication with others can result in an increase in the individual's use of *special keywords* and contribute to one's *individualisation* of this learning, or one's "independent critical appreciation and interrogation of mathematical concepts" (Vygotsky, 1978, as cited in Walshaw, 2016, p. 18).

The next subsection discusses the crucial role that *visual mediators* play in students' learning. The subsection begins with a brief review of the literature, drawing on the work of Sfard (2008) and McNeill (1992) that specifically pertains to the discussion with regard to *visual mediators*.

#### **6.4.1.2 Changes in communication related to the use of visual mediators**

The second characteristic, according to Sfard's (2008) commognitive approach, that influences students' mathematical discourse and thus their learning is *visual mediators*. Visual mediators include the visual signs and symbols used in the communication aspect of mathematical teaching and learning. Within the context of this study, these included the external representations (i.e., physical or virtual materials), as well as the teacher's or students' interactions with these representations revealed through acts of embodiment, such as the use of gestures.

VM students were participating in more communicative procedures as compared with PM students. VM students utilised a wider range and greater frequency of gestures as compared to PM students (see sections 5.3.1.1 and 5.3.1.2). The most noticeable increase in gesture use was

observed within the *iconic gesture* (G2) category. While PM students began to use *iconic gestures* (G2) in the Enhance: Guide Application phase and continued to use them in the Synthesise phase, VM students used *iconic gestures* (G2) more frequently throughout all lesson phases (see Figure 5.15, section 5.3.1.2). Thus, VM students' increased use of *iconic gestures* (G2) could be considered to show increased levels of "concretization" of the concept being explored (Sfard, 2009). That is, it appeared that VM students had progressed further towards the abstraction of the spatial concept from its visual representation (Sfard, 2009) as compared to the PM students.

Thus, VM students were engaging in more frequent sense-making practices as compared to PM students. This helped them reach more in-depth understanding of the associated mathematics. Sfard (2009) argued that the use of *iconic gestures* provides a necessary step in the process towards visual imagery. As stated by Sinclair et al. (2016) *iconic gestures* in this process of objectification are "illustrative of imagined re-enactions of previously experienced activities and ... emerge in instructional situations as embodied abstractions, serving a central role in the sense-making practices associated with the appropriation of mathematical meaning" (p. 701).

Further evidence that supports VM students' greater movement towards abstraction is their use of *iconic gestures* (G2) and *metaphoric gestures* (G3) in combination in the Synthesise phase of lessons (see Table 5.18, section 5.3.1.2). The use of *metaphoric gestures* (G3) allows students to "exhibit images of abstract concepts" (McNeill, 1985, p. 356). The combination of both *iconic* (G2) and *metaphoric gestures* (G3) by VM students outwardly showed the depth of their visual imagery and helped them to clarify their communication. An example of this is drawn from Lesson 3 (see Table 5.18, section 5.3.1.2). This example shows how students were using gestures to show their understanding of more abstract ideas. The *iconic gestures* used by the student (S39) for "sections" (i.e., a cutting-like gesture using both hands to display a section of an imaginary object) and "highest" (i.e., hand raised up high) outwardly showed her visual imagery relating to "sectioning" something and her visual imagery of "highest" as vertically framed. This gestural sequence became more complex when this student continued the discourse with a *metaphoric gesture* (G3). She gestured the utterance of "how high" as an upward counting motion with her hand with each gap being approximately the same. The use of this *metaphoric gesture* (G3) revealed that this student was developing deeper levels of understanding by drawing on and connecting other mathematical areas (i.e., her visual image of a number sequence) to her description of the position and location of objects. As shown in this example, these types of representational gestures (i.e., *iconic* and *metaphoric gestures*) are imagistic gestures and serve several functions, such as (a) depicting imagery (McNeill, 1992);

(b) serving as an important bridge between the private, internal imagery (which can be difficult to express in words) and the formal, symbolic expression of mathematical ideas (Arzarello, 2006); and (c) providing students with an opportunity to clarify space and shape aspects of abstract knowledge (Elia et al., 2014).

This complexity of gesture use by the VM students begins to illustrate the process of *objectification*, in moving from the concept of an action towards a structural concept (i.e., an object). In other words, students used *iconic* and *metaphoric gestures* to link previously experienced actions to an abstract concept. In the process of transcending the physical and proceeding to more advanced levels of mathematical abstraction, “gestures and other visual mediators constitute the material of which the abstraction (e.g., mathematical objects) are produced, one layer after another” (Sfard, 2009, p. 193). From this perspective, the results of this study indicate that VM students’ increased use of gestures was moving their learning away from the concrete and, therefore, they were beginning to develop more advanced levels of abstraction.

Additionally, the increase in VM students’ use of *iconic* and *metaphoric gestures* acted as an indicator to the teacher that higher levels of scaffolding could be applied to students’ learning as these students were beginning to operate within higher levels of spatial thinking. It should be noted that the response by the teacher relies heavily on her willingness to accept the change in teacher–learner agreement, change the teaching practices she planned to use, and draw on her subject matter knowledge in this area of mathematics. These required changes are further discussed in section 6.4.2.

Finally, VM students’ limited use of *body positioning* (BP) further supports the notion of their enhanced progression towards the abstraction of the spatial concept. Results revealed that VM students used limited changes in their body position in the learning of spatial concepts (see Table 5.14, section 5.3.1.2). In contrast with the PM students, VM students were using multiple gestures (i.e., *iconic* and *metaphoric*) to visually represent what would have previously been physically acted upon. For example (see Table 5.15, section 5.3.1.2), instead of S42 physically moving around the virtual manipulative to discuss different viewpoints, the student was gesturing the movement. S42 gestured the movement with the *iconic gesture* (G2) of rotating her hand around and back again. Producing the *iconic gesture* of rotating her hand seemed to indicate that S42 was doing the rotation in her mind. Some aspect of mental rotation through visual imagery was occurring. However, it is uncertain if the mental transformation S42 applied was (a) imagining the rotation of the object until the desired viewpoint was aligned with her current perspective; or (b) imagining moving herself around the objects to the new viewpoint (Wraga, Shephard, Church, Inati, & Kosslyn, 2005). However, in this study, it appeared that the use of

*iconic gestures* provided the necessary step in the process towards visual imagery (Sfard, 2009). Therefore, it was speculated that VM students had moved beyond the physicality of the representations and had begun to apply imagery. Given the importance of imagery to abstraction, investigation into the types of mental rotations (imaging the rotation or imaging yourself moving) that are produced in students' spatial learning with VM, especially in the early years, warrants further attention.

Further examination of changes to VM students' use of gestures indicated that VM students used *grounding gestures* (GE) more frequently than PM students in the Enhance: Guided Application phase (see Table 5.14, section 5.3.1.2). As this change related to students' interaction with the iPad and coincided with students' peer scaffolding, these changes are discussed in the *routines* section (6.3.1.4).

In summary, this study aligns with Sfard's (2009) belief that gestures (as *visual mediators*) are crucial to the effectiveness of mathematical communication. Sfard defines effective communication as all interlocutors realising the focal nouns in the same way (Sfard, 2009). In other words, communication is effective if all participants are speaking about the same thing. VM students' increased use of *visual mediators* added to the communicative aspect of students' discourse. Increased use of *pointing* (G1) and *iconic gestures* (G2) acted as tools of clarification to students' *mathematical words* (see Table 5.15 and Table 5.16, section 5.3.1.2). Moreover, these gestures acted as virtual realisations of nouns used when physical representations were not present. Sfard (2009) acknowledged this idea by drawing on the work of Edwards (2009), who noted that *iconic gestures* create an imagery of the concept for parts of the realisation that are imagined and not physically present. Therefore, the use of *iconic gestures* allowed all participants in the mathematical discourse to realise the objects of mathematical discussion. These findings support Sfard's (2009) claim that gestures provided the medium in which realisation can take place and that the use of gestures makes realising procedures public to interlocutors. This perspective also expands on Alibali et al.'s (2014) research that demonstrated the positive effects of gestures on students' comprehension of concepts by making them "visible" to students.

Overall, the analysis of changes in VM students' gestures adds to Sfard's (2009) belief that the combination of *mathematical words* (verbal descriptions) and *visual mediators* (in particular, gestures) is required to make communication more effective. This is further discussed in the next subsection, which explores the relationship between *mathematical words* and *visual mediators*.

### 6.4.1.3 *The relationship between mathematical words and visual mediators*

The discussion thus far has indicated the importance of *mathematical words* and *visual mediators* in students' communication and thus, their learning. However, the relationship between these two characteristics and how they interact with each other needs further examination. From the finding of this study it is suggested that Sfard's notion on the role of *visual mediators* be extended to include that the simultaneous use of gestures creates mathematical discourse that is more in-depth. This section pertains to discussions with regard to this claim and to the different communication functions that each characteristic serves in mathematical discourse and whether each characteristic is capable of existing on its own to form effective communication.

The first view discussed is that gestures can communicate student learning independently. While most literature on gestures relates to its interaction with speech, some researchers suggest that gesture is not simply an epiphenomenon of speech or thought (Goldin-Meadow, 2003; McNeill, 1992; Moschkovich, 2007), but can shape thought (Goldin-Meadow, 2003). Previous gesture research suggests that "even a student who is missing vocabulary may be proficient in describing patterns, using mathematical constructions, or presenting mathematically sound arguments" (Moschkovich, 2007, p. 20). Within this study, while the use of gestures with limited language was evident in the PM class, these gestures themselves were somewhat simple gestures, such as *pointing* (G1) rather than *metaphorical* (G3) (see section 5.2.2.2). Thus, their contribution to creating ideas seemed limited. In the VM class, there were no examples where gestures were used without the use of complex levels of *mathematical words* and *visual mediators*. There were no instances where gestures were being used without being accompanied by speech. Given that the PM and VM classes were "matched" in terms of ability, socio-economic status, and proportion of English as a second language learners, the role that particular representations play in the communication process requires further investigation.

The second view discussed is that effective communication can occur with complex forms of *mathematical words* and limited use of *visual mediators*. While Sfard (2009) acknowledged the importance of *mathematical words* and *visual mediators* in communication, her understanding of the relationship between these two characteristics places more emphasis on *mathematical words*. *Visual mediators* only play a complementary role. In her view, *mathematical words* and *visual mediators* act as communicational functions of student thinking and have a symbiotic relationship, as each form of communication acts as a "backup" to the other (Sfard, 2009). This idea offers the possibility that *mathematical words* in effective communication could exist without the use of gesture. This stance was not evident in the

findings of this research, as gestures were required to clarify the *mathematical words* used. An example of VM students using mathematical words with limited gestures occurred during the symmetry lesson when the mathematical discourse was negotiating the definition of the term “symmetry” (see Table 4.43 and section 5.3.2). While occurrence of mathematical words without gestures did exist in the VM class, the communication was not effective and often the teacher used *reviewing* scaffolding practices to clarify the communication (e.g., Utterances 27–28 in Table 4.43). S35 expanded the idea of symmetry with a complex sentence, “something that you can fold and it will look the same on both sides” (see section 6.4.1.1). This utterance, however, was only complemented by a single gesture of moving her hand across her body to signify the “fold”. While an *iconic gesture* (G2) was used, it was unlike the complex combination of gestures that was evident in many of the VM student communications (see section 5.3.1.2). This indicates that *mathematical words* have the potential to stand alone in the communicational act. While this occurrence of *mathematical words* with limited *visual mediators* was occasional in the VM class, previous discussions in the *visual mediators* section indicated that more effective communication and therefore deeper levels of spatial thinking were achieved when both *mathematical words* and *visual mediators* were used together (see section 6.4.1.2). The implications that this has with regard to teaching in these contexts are discussed in section 6.4.2.

The last view to be discussed relates to the inseparability of these two characteristics (*mathematical words* and *visual mediators*) and that both are required for effective communication. In contrast to Sfard, McNeill (1992) viewed the relationship of *mathematical words* (utterances) and *visual mediators* (gestures) as occurring simultaneously. As discussed in the previous sections on *mathematical words* and *visual mediators*, the findings of this study reveal that simultaneous, increased complexity of both these characteristics was evident in VM students’ mathematical discourse (see sections 6.4.1.1 and 6.4.1.2). Thus, *visual mediators* seemed to not just act as a “back-up” to *mathematical words*, but accompanied the formulation of *mathematical words* (see Table 5.15, section 5.3.1.2). Whether gestures were the impetus for language or language was the impetus for gestures could not be identified. Thus, these results do not necessarily add to either side of the debate: Students remember words more when they use gestures (Goldin-Meadow, 2000, 2003) or “these actions [gestures] are often remembered by our bodies much better than words are remembered by our minds” (Sfard, 2009, p. 199); and words act as indexes to gestures (Roth & Thom, 2009). However, the results of this study suggest that *visual mediators* not only provide clarification to *mathematical words* but may also assist in progressing students’ spatial thinking from the physical towards abstraction (see section 6.4.1.2). This study’s findings indicate that this symbiotic relationship does exist and



that the simultaneous use of both *mathematical words* and *visual mediators* in mathematical discourse enhances student spatial thinking.

The findings of this research suggest that when *mathematical words* and *visual mediators* align they act as an indicator that students are ready for more in-depth learning experiences (see section 5.3.1.2). This idea of the necessity of both forms of communication (i.e., *mathematical words* and *visual mediators*) also relates back to earlier discussion on dual coding theory (see section 6.3.2.1, Levels occurring simultaneously). As previously discussed, the theory of dual coding denotes that both pictorial/visual and verbal channels are required when students are learning (Mayer, 2005; Sweller, 1999). The use of *mathematical words* and *visual mediators* allows students to access both channels, and thus limits the cognitive load on working memory (Mayer, 2005). In addition, “gesturing on a maths task that has spatial components may allow children to encode into their visuo-spatial representations information that without gesture would have been encoded in verbal form” (Goldin-Meadow, 2000, p. 236). While the dual coding theory applies to students’ learning and the receiving of information, its application to teaching encompasses what the teacher interprets as students communicate using both channels. Additionally, as the teacher observes students’ *mathematical words* and *visual mediators* simultaneously, observation of “mismatches” could occur, which allows the teacher to attend to “commognitive conflict” or further develop students’ spatial thinking.

The VM students’ increased communication provided the teacher with increased opportunity to interpret situations of *commognitive conflict* and therefore apply mediation to resolve the conflict. If the teacher identified *commognitive conflict*, Level 2 scaffolding practices were applied (see section 4.3.2.2). However, if students’ mathematical discourse was interpreted as effective communication (i.e., their *mathematical words* and *visual mediators* matched) then Level 3 scaffolding practices were applied (see section 4.3.2.2). The idea of *commognitive conflict* “rests on the assumptions that learning, as a change of discourse, is most likely to result from interactions with others” (Sfard, 2008, p. 257). Therefore, the role of the teacher or an MKO is required in the mediation. Sfard refers to changes in the teacher’s role as a change in the *learning–teaching agreement* and this is explored further in section 6.4.2.

#### **6.3.1.4 Changes in routines**

The third characteristic, according to Sfard’s (2008) commognitive approach, that influences students’ mathematical discourse and thus their learning is *routines*. The purpose of mathematical *routines* is to produce narratives that can be endorsed (Sfard, 2008). In this

subsection, changes to students' *routines* are discussed in terms of students' progression from one type of routine to another.

The first change in VM students' *routines* related to their increased communication. As discussed in the section relating to *visual mediators* (i.e., the example of students progressing towards mathematical abstraction; see section 6.4.1.2), VM students were using a greater range and frequency of *visual mediators* (gestures) in their communications. The increased complexity of *visual mediator* use, and movement towards mathematical abstraction, exemplified VM students' progression towards explorations, that is, a change in routines from physical action and manipulation of an object, known as *deeds*, towards the development of exploration of endorsed narratives (Sfard, 2008).

As compared to PM students, VM students were participating in both deed and exploration routines and therefore were becoming more fluent in the mathematical discourse of spatial thinking. The change in the VM students' routines indicated that they were on their way to meta-learning. This change, evident through their increased communication (i.e., using more complex forms of *mathematical words* and *visual mediators*) appeared to create greater opportunities for new discourse to develop. In the PM class, students' discursive routines were almost solely based in *deeds* (manipulation of physical manipulatives). The grounding of the routine in *deeds* was evident through students' use of *pointing* and *iconic gestures* in the Enhance: Guided Application phase (see section 6.4.1.2). Identification of this discourse as *deed routines* was, furthermore, supported by the PM students' use of limited *mathematical words* such as "I see a flat side here" (coupled with the *iconic gesture* for "flat" and *pointing gesture* for "here"), and "this one is closer than this one" (clarified with *pointing gestures* to identify position; see Table 5.7). These routines were classified as *deeds* because they related to changes that were found in the environment. In contrast, while VM students were still operating in *deeds*, their use of more complex *iconic* and *metaphoric gestures* appeared to illustrate their use of visual imagery and a movement towards mathematical abstraction (see Table 5.18 and section 6.4.1.2), signifying progression towards *exploration routines*. These students had begun to step away from the manipulation of virtual objects and were beginning to "get to know" the mathematical discourse involved in the spatial thinking (Sfard, 2008). According to Sfard, "one of the indications of the student's fluency in numerical discourse is their ability to alternate between the modes of deeds and of explorations" (Sfard, 2008, p. 241).

## 6.4.2 Changes to the teacher–learner agreement

Changes in *routines* also influenced a change to the *teacher–learner agreement*. The influences on this agreement are presented in three subsections: changes that occurred as a result of the apps; changes that occurred as a result of peer scaffolding; and the influences both of these changes had on the teacher’s teaching in the VM classroom. The implications of these changes for the teacher–learner agreement are discussed in the final subsection.

### 6.4.2.1 Changes to the teacher–learner agreement influenced by the use of iPad apps

The embedded features found in the iPad (i.e., multimodal instructions and direct real-time feedback) resulted in the iPad attending to some scaffolding practices as the “expert of the discourse”. This change appeared to result in students being more in control of their learning and therefore experiencing greater autonomy (Herrington, Herrington, Mantei, Olney, & Ferry, 2009; M. Wood, 2016). This increased autonomy led to students communicating more with each other, and beginning to peer-scaffold. Therefore, the unique features embedded in the iPad contributed to and changed the social and cultural interactions between students by promoting collaborative learning (Henderson & Yeow, 2012), and creating a change in the *teacher–learner agreement*.

The multimodality embedded in the iPad apps allowed students to receive explaining scaffolds (2Ex) via the two channels as explained in the dual coding theory (i.e., verbal and visual). The iPad was using the “discourse of the expert” (Sfard & Cobb, 2014, p. 58) and was providing scaffolding for students as an MKO (Vygotsky, 1978). Therefore, as the discourse used by the “expert” was sent via two channels of communication (i.e., verbal and visual; Mayer & Anderson, 1991), it is suggested that students’ use of the iPad also promoted the *routine* of using both forms of communication (*mathematical words* and gestures as *visual mediators*) in their own mathematical discourse when discussing their spatial thinking (see Table 5.15, Table 5.16, Table 5.17, Table 5.18 in section 5.3.1.2 and Table 5.20 in section 5.3.2).

The multimodality in the iPad apps provided VM students with multiple examples of spatial tasks, which positively influenced the development of their spatial thinking. Previous studies have shown that this multimodality, that is, adding non-verbal representations to verbal explanations (a) enhances students’ understanding (Murcia, 2012, 2014); (b) promotes deep cognitive processing (Moreno & Mayer, 2007); and (c) has the potential to reduce students’ cognitive load, while still preserving the underlying mathematical content (Bertolo et al., 2014; Ladel & Kortenkamp, 2013). Therefore, it is conjectured that the multimodal representations used within this study further enhanced the development of VM students’ spatial thinking.

In addition to the multimodal feature, some of the apps contained an added feature of “direct real-time feedback” (Leichtenstern, André, & Vogt, 2007), which further enhanced the mathematical discourse that occurred. The use of direct real-time feedback provided students with information on appropriate examples and non-examples of the spatial tasks. Within the context of this study, this added feature attended to some of the Level 2 scaffolding practices that the teacher as the “expert of the discourse” was previously responsible for. Aligning with the results from past studies in this area (e.g., Henderson & Yeow, 2012; Paek, Hoffman, Saravanos, Black, & Kinzer, 2011), it is conjectured that this feature impacted on VM students’ learning and helped create an environment where students were sharing their ideas with their peers.

Finally, the use of apps promoted students’ gestural communication, which in turn further supported their development of visual imagery, and changed who was leading the discourse. Students’ peer scaffolding resulted in increased occurrence of *grounding gestures* (GE), such as students touching and interacting physically with the iPad (see Table 5.17, section 5.3.1.2). The use of the iPad apps had resulted in a change of who was leading the discourse, therefore changing the *teacher–learner agreement*. When students were modelling their communications to others, they touched the iPad and produced a dragging motion. While this study classified this gesture as a *grounding gesture* (GE), to align with the PM students’ use of grounding gestures when interacting with physical manipulatives (i.e., students were grounding their communication to the environment), recent literature has explored this gesture classification as embodied actions of “dragging” when using virtual manipulatives (Ng, 2014).

Using Sfard’s analytical framework, Ng’s studies (2014, 2016) showed that some dragging actions were not merely dragging but also instances of gestural communication, where “touchscreen-dragging modality allows the dragging with one finger on the touchscreen and the gesturing with the index finger to blend together as one action” (Ng, 2016, p. 311). While this present study did not examine these dragging gestures as a separate category, evidence of these actions did exist in its findings (see Table 5.17, section 5.3.1.2). This evidence suggests that McNeill’s (1992) gesture classifications need to be further extended to include this gesture. As Ng (2016) claimed, dragging adds to students’ mathematical discourse because it acts both as a communicative function by gesturing and as part of a meta-level routine attended to by students. Additionally, dragging as a combined gesture with iconic or metaphoric gestures could also assist in furthering the development of students’ visual imagery and progressing students towards mathematical abstraction. However, as this was not examined within the context of this study, further investigation into the influences of dragging gestures on students’ spatial thinking is required.

#### 6.4.2.2 Changes to the teacher–learner agreement influenced by peer scaffolding

The second influence on the VM students' *teacher–learner agreement* related to the increased instances of peer scaffolding. As students in the VM class were beginning to peer-scaffold during the lessons (see section 4.3.2.2, Phase 1 – Orientate: Students becoming active engagers in the scaffolding process; and section 4.3.2.2, Phases 2 and 3 – Enhance: Explicit Modelling and Guided Application: Increased student peer scaffolding), there was a change in who led the discourse. This change to the *teacher–learner agreement* was evident in Table 4.47 (see section 4.3.2.2.) with S37's adoption of the role of the "expert in the discourse" (teacher), and S42's acceptance of S37's role as the authority.

Peer scaffolding or reciprocal scaffolding (Holton & Clarke, 2006) appeared to empower the learner by progressively devolving the role of scaffolding agent from the teacher to the learner (e.g., S42 adopted a peer-scaffolding role, see Table 4.48), and reduce the cognitive load of learners (e.g., Myhill & Warren, 2005; Turner et al., 1998; Van Merriënboer, Kirschner, & Kester, 2003). This was evident when S37 was reducing the cognitive load of S42 by providing the routines in how to approach the symmetry task. Therefore, S42 was provided with the opportunity to reduce his cognitive load on the mechanics of performing the task and focus more on the spatial thinking required. Hence, the peer, as the "expert" participant in the discourse, was acting as a co-constructor of meaning making and learning (Bakhtin, 1981). A "transfer of responsibility" had begun to occur (Van de Pol et al., 2010), allowing for more effective learning. This change in the *teacher–learner agreement* consequently influenced what scaffolding practices the teacher herself then implemented (Anghileri, 2006).

This study also supports Sfard's notion that the resolution of commognitive conflict between peers impacts on the *teacher–learner agreement* (see Table 4.47, section 4.3.2.2). Sfard (2001) argued that most opportunities for mathematics learning come from commognitive conflict, and it is a necessary condition for learning (Sfard, 2008). In the preceding example, S42 was unclear of his spatial thinking for the task, therefore sought assistance from his peer. The *visual mediators* (i.e., dragging actions) used by S37 as the "expert" participant in the discourse were conflicting with the *visual mediators* used by S42. Development of a new discourse (Sfard, 2001, 2008) was evident in the Utterance 150, "You have to make a copy." S42 had begun to question his own routine and slowly started to adopt the routine of S37. At this stage, S42 had recognised a disagreement in the different *visual mediators* used to complete the symmetry task, listened to the communication from the other students, and accepted S37's role as the "expert". The recognition of the commognitive conflict between the students acted as a "gate to the new discourse" (Sfard, 2008, p. 282). Learning occurred as a result from

“interactions with others” (Sfard, 2008, p. 257). Meta-level discussions (Sfard, 2008) were occurring where the commognitive conflict was resolved and students together adopted a new discourse. Therefore, with a change to the discourse, student learning was evident.

Students who were providing peer scaffolding had advanced and progressed towards a process of *individualisation* (Sfard, 2008). In other words, students progressed from mere observers of the mathematical discourse to actually facilitating the learning process of others by acting as the MKO (Vygotsky, 1978) or “expert participant” in the discourse (Sfard & Cobb, 2014). In these instances of peer scaffolding, students not only had to communicate with themselves about their own spatial thinking, but also had to communicate these “thoughts” with peers in the role of the leading “expert” of the discourse. This change in the *teacher–learner agreement* further indicated that students were becoming more autonomous in the learning process (M. Wood, 2016), suggesting that students acting in the role of an “expert participant” in the discourse during peer scaffolding resulted in a change in *routines*, and thus is a crucial component of students developing their own narratives.

#### **6.4.2.3 Changes in the teacher’s teaching**

The third influence on the *teacher–learner agreement* in the VM class was related to changes in the teacher’s teaching. It appears that the unique features of the iPad (i.e., multimodal representations and direct real-time feedback) and the presence of peer scaffolding influenced a change in the teacher’s communication (i.e., use of *mathematical words* and *visual mediators*) and the implementation of more challenging scaffolding practices. The findings of the teaching section of this study (section 4.3.4) revealed an increase in the teacher’s number of *special keywords* and their frequency of use (see Table 4.55, section 4.3.4.1), increased usage of more complex forms of *visual mediators* (see Table 4.56, section 4.3.4), and increased usage of Level 3 scaffolding practices (see Table 4.54, section 4.3.3) in the VM class.

Sfard’s commognitive approach is not limited to examining learning but also provides insights into the discourse associated with the teaching–learning process, and the relationship between these two constructs. The change in VM students’ use of *mathematical words* influenced the change in the teacher’s use of *special keywords*. The discussion pertaining to VM students’ learning (see section 6.4.1) revealed an increased use of *mathematical words*, which evidenced students’ progression towards *objectification* (see section 6.4.1.1); use of *saming* (see section 6.4.1.1); movement from informal, everyday words to formal terms (see section 6.4.1.1); and students’ use of appropriation, demonstrating their progression towards a process of individualisation (see section 6.4.1.1). This evidence showed a movement or a progression in VM

students' learning compared to the PM class. As students were exhibiting these signs of learning, the teacher also progressed her use of *mathematical words* (see Table 4.55, section 4.3.4.1).

The results from this study indicate that students' learning (or their communication) can be heavily influenced by the teacher's access and use of content knowledge in the teaching process. In order to progress her use of *mathematical words*, the teacher required a deep knowledge of more advanced forms of *mathematical words* (in particular, *special keywords* or technical mathematical vocabulary) related to the spatial concept being explored (see Table 4.55, section 4.3.4.1 and Appendix R), and this knowledge needed to be easily accessible. In other words, the teacher required deep content knowledge (Shulman, 1986) of the spatial concept. Over the past decade, many researchers have acknowledged how teachers' deep content knowledge (CK) positively affects student learning in mathematics classrooms (Campbell et al., 2014; Hill et al., 2005). The results of this study support these prior findings.

Students' increased use of more complex *mathematical words* influenced a change in the teacher's *mathematical words* and scaffolding practices, and consequently drew on her pedagogical knowledge required to expand students' spatial thinking. Students' increased use of *mathematical words* acted as a driver for the teacher's use of *mathematical words*. This was evidenced in the example of a student's use of appropriation demonstrating their progression towards a process of individualisation (see section 6.4.1.1). As the student had shown deeper cognitive understanding of the spatial orientation concept through advancement in their mathematical words (i.e., use of the special keyword "degrees"), the teacher then had to access deeper levels of content knowledge related to the spatial concept. This resulted in the teacher *explaining* (2Ex) the concept, by using more *mathematical words* related to the concept. This was evidenced in Utterance 35 where the teacher explained, "Basically you are flipping it aren't you? Doing a full turn around, or flipping it halfway around." This progression of *mathematical words*, which required deeper content knowledge related to angles, further resulted in the teacher's use of higher-level scaffolding practices. Again, this movement is heavily reliant on the teacher's pedagogical content knowledge, and willingness to engage in the discussion. In this case, it required the teacher to choose to abandon her planned sequence of scaffolding practices as delineated in her lesson plan.

While Sfard's (2008) claim that the ritual phase in *routines* is inevitable in mathematics, this study shows that the adoption of these rituals can be a reciprocal process, and can be adopted by the teacher to further promote the autonomy of students. For example, VM students' increased use of *visual mediators* (see section 6.4.1.2) had a similar influence on the teacher's use of *visual mediators*. VM students' increased use of more complex *visual mediators*

signalled their progression towards abstraction in their spatial thinking. This drove an increase in the teacher's use of *visual mediators*. The teacher's increased use of *visual mediators* assisted in creating visual imagery for students to either further their progression towards abstraction (see Table 4.41, section 4.3.2.2) or as a clarification tool (see Table 4.42, section 4.3.2.2). When used as a clarification tool, the teacher ritualised students' *iconic gestures* by mimicking the student. This act of ritualising the student's use of *visual mediators* further illuminates Sfard's (2008) claim. Thus, Arzarello's (2006) assertion that visual mediators can serve as a bridge between the imagery and the mathematical idea applies to both the teacher and the students.

The co-occurrence of *mathematical words* and *visual mediators* strengthens and extends the notion that the relationship between mathematical words and visual mediators is symbiotic as one learns (Goldin-Meadow et al., 2001; McNeill, 1992; Novack & Goldin-Meadow, 2015). However, in this present study this relationship appeared somewhat symbiotic between the learning and teaching processes themselves. The influence of students' increased communication (i.e., *mathematical words* and *visual mediators*) on the teaching of spatial thinking was that the teacher also used more complex forms of communication. Therefore, for this to successfully occur, the teacher required a deep knowledge of *mathematical words* and *visual mediators* related to the spatial content knowledge. The teacher needed to be able to identify students' current level of spatial thinking (which was evident through their communication analysed through their use of *mathematical words* and *visual mediators*) and extend students' learning by having access to deep content knowledge. While Sfard (2008) acknowledged that in student learning, increases in complexity of *mathematical words* and *visual mediators* (McNeill, 1992) show a progression in students' mathematical learning, in past studies there has been little attention given to the importance of the teacher or the "expert" being able to progress their own *mathematical words* and *visual mediators* in order to support and extend students' learning. This study highlights the importance of having a knowledgeable leader or "expert" as a partaker in this discourse.

The teacher's use of more complex forms of *mathematical words* and *visual mediators* also resulted in higher levels of scaffolding being implemented (see section 4.3.4). Thus, to "run with students' discourse" the teacher required a deep pedagogical knowledge as well as deep and broad content knowledge (knowledge of the subject). The teacher was required not only to have deeper levels of content knowledge related to the spatial concepts, but also to access deeper levels of pedagogical content knowledge on how to make the mathematics accessible to students (Shulman, 1986). These types of knowledge were utilised in three



different aspects of the teaching process: clarifying the learning, extending the learning, and addressing misconceptions as they became evident.

Overall, as the *teacher–learner agreement* changed, the teacher became aware of when these changes occurred, acknowledged these changes and implemented scaffolding practices that would continue to operate within students’ ZPD (Vygotsky, 1978). For this to happen the teacher had to have a deeper understanding of the spatial concept in terms of both mathematical content and pedagogical knowledge. There was also a need for the teacher to understand that students could take over the role as the “expert” participant who would attend to lower-level scaffolding practices (see Table 4.43 and section 5.3.2, where students were beginning to peer-scaffold). This change in routine then allowed the teacher as the “expert” to apply higher-level scaffolding practices to extend students to the next level of learning (see Utterance 33 in Table 4.43 and section 5.3.3).

While Anghileri (2006) acknowledged “peer collaboration” in her scaffolding framework, the results of this study suggest that the role of students as “experts” in the discourse requires further investigation. The results of this study also draw connections to the use of peer scaffolding to act as a gateway for the teacher to attend to higher-level scaffolding practices. Figure 6.10 presents a diagram illustrating the influences on the teacher–learner agreement within the VM class.

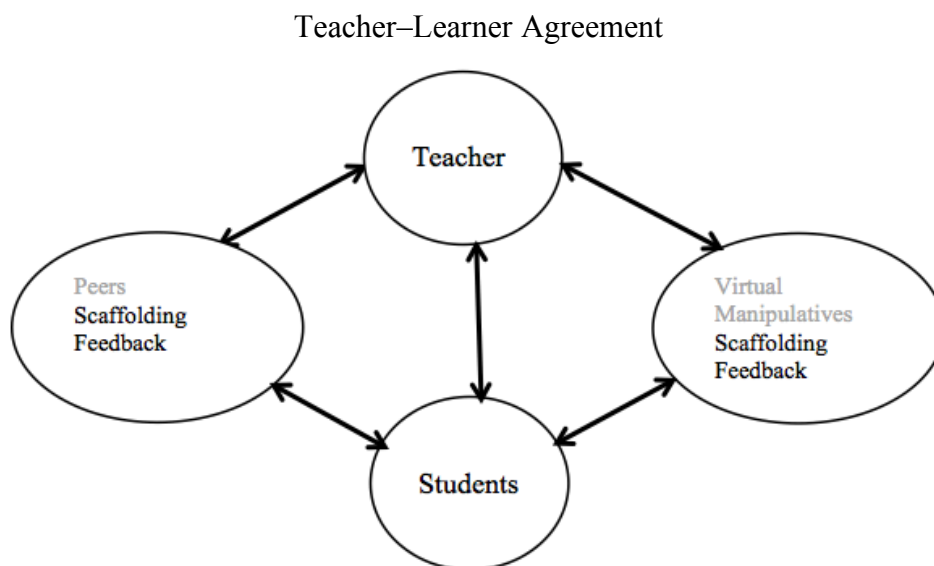

Figure 6.10. The teacher–learner agreement within the VM class.

Represented in Figure 6.10, the teacher–learner agreement was influenced not only by the virtual manipulatives used, but also by the involvement of students in the feedback and scaffolding process. This appeared to indicate that students were taking more control of their own learning, and the teacher supported this occurring. This change in the teacher–learner

agreement in the VM class contradicted the findings on the teacher–learner agreement that was established in the PM class (see Figure 6.7).

#### ***6.4.2.4 Implication of changes to the teacher–learner agreement for the teaching***

The implication of these findings with regard to teaching and learning spatial concepts using virtual manipulatives is that these virtual manipulatives inadvertently impacted and changed the role of the teacher. When students displayed higher levels of spatial thinking (evident through their communication and peer scaffolding), the teacher needed to access deeper levels of content and pedagogical content knowledge (and scaffolding practices). This highlights the important role of the teacher as a “strategically placed actor” (Heyd-Metzuyanim & Graven, 2016, p. 370) in the teaching and learning of spatial thinking skills. Thus, it is argued that the teacher herself played a very important part in the progression of these students’ learning. However, the question that remains is:

*If the teacher had not positively responded to the changes in routines that occurred, would the VM students’ learning have progressed to the levels exhibited in these findings?*

## **6.5 CHAPTER REVIEW**

Within this chapter, the findings that emerged from the study were examined, reviewed and discussed in relation to the literature and theoretical frameworks regarding the teaching and learning of spatial thinking. A new model was developed to include the theoretical framework of Van Hiele’s (1986) development of geometric thought and the practical suggestions of Anghileri’s (2006) hierarchy of scaffolding practices. This new model suggested a structure for the teaching of spatial thinking with physical materials. However, this model did not align with the teaching implemented in the VM classroom. Discussion of students’ learning in the VM class occurred using Sfard’s (2008) commognitive theoretical and analytical framework to acknowledge changes in students’ spatial learning. These changes appeared to be influenced by the unique features of the virtual manipulatives, and students attending to peer scaffolding. Furthermore, changes in VM students’ learning appeared to influence a change in the role of the teacher and the teaching of spatial thinking.

Chapter 7 addresses the research questions and presents the limitations, recommendations and further research considerations.

# Chapter 7: Conclusions and Recommendations

---

## 7.1 CHAPTER OVERVIEW

This concluding chapter reviews the findings of the study in relation to the research questions and develops a theory on the teaching and learning of spatial thinking when using manipulatives. Conclusions are presented, practical implications are discussed and areas of further research are delineated. Figure 7.1 presents an overview for the chapter.

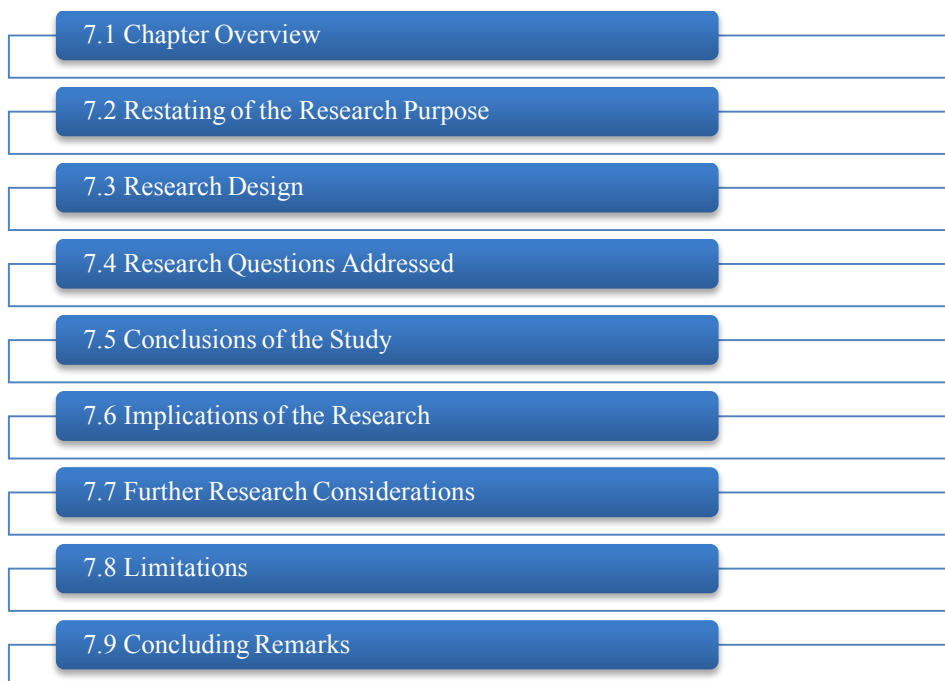

*Figure 7.1.* Overview of Chapter 7.

## 7.2 RESTATING OF THE RESEARCH PURPOSE

The purpose of this research was to explore the use and influences of external representations (i.e., the use of physical manipulatives or virtual manipulatives) on the teaching and learning of spatial thinking with young students. Sociocultural theory provided a theoretical framework for exploring the phenomenon of young students' learning of spatial thinking within the context of educationally disadvantaged students. This study was motivated by the limited research pertaining to the influences of manipulatives on young students' learning of spatial thinking. It proposes to begin to fill the gaps in recent literature with regard to how young students from disadvantaged backgrounds can be supported to think spatially.

In line with the purpose of the study, the overall aim was to investigate the influence that physical manipulatives and virtual manipulatives have on the teaching and learning process of Year 3 students (aged 8–9 years) as they engage in spatial thinking. The first part of the aim involved exploring the influence of different external representations (i.e., physical and virtual manipulatives) on young disadvantaged students' learning of spatial thinking. The second part of the aim involved investigating the changes that occurred to the teaching and learning process within a mathematics classroom as a result of using these different manipulatives. This included exploring the relationship between teaching pedagogy and students' learning, and the influences these had on each other.

### 7.3 RESEARCH DESIGN

The study contributes to the body of research with regard to young students' learning of spatial thinking.

The following research questions provided direction for the design of the study:

1. *What influence do different external representations (e.g., physical manipulatives and virtual manipulatives) have on young students' learning of spatial thinking?*
2. *What changes occur in the teaching and learning of spatial thinking when using different external representations (e.g., physical manipulatives and virtual manipulatives)?*

Because the study explores young students' spatial thinking as they construct their knowledge from the interactions they experience with external representations, an interpretive paradigm was an appropriate epistemological, ontological and methodological stance adopted for the research. During this process, students used language, gestures and other social interactions to assist in the creation of their understanding. Thus, this epistemology allowed for the exploration of students' spatial thinking as they constructed their knowledge from a known context, the manipulation of objects within their environment.

Practical application of a sociocultural perspective required a narrowing of this lens so as to pinpoint particular aspects of the teaching of spatial thinking and students' learning of spatial thinking. Within this study, the narrowing of this lens entailed the use of Anghileri's hierarchy of scaffolding practices (2006) and Sfard's commognitive approach (2008). The adoption of both these theories provided a more in-depth analysis of the interactions between students and teacher when considering (a) the influence of external representations on students' learning of spatial thinking, and (b) the changes that occurred in the teaching and learning of spatial thinking.

As the aim of the study was concerned with exploring the use of representations (i.e., physical manipulatives and virtual manipulatives) in the teaching and learning process and their influence on Year 3 students (aged 8–9 years), teaching experiments were adopted as the research methodology. The purpose of the teaching experiments was to directly experience students' learning of spatial thinking. In order to observe the impact each intervention (i.e., either physical or virtual manipulatives) had on students' learning of spatial thinking, a quasi-experimental design was utilised. A quasi-experimental design ensured that the natural setting was preserved as the interactions that support the development of students' spatial thinking were investigated.

The research was conducted in three Year 3 classrooms (8–9 year olds) from two disadvantaged schools in south-east Queensland. In total, 68 students participated in the study. Two classes (50 students) from School A participated in the quasi-experimental teaching experiments: PM class ( $n = 23$ ) and VM class ( $n = 27$ ). One class from School B ( $n = 18$ ) participated as the Control class. The researcher was also a participant of the study as she adopted the role of the teacher during the data collection phase.

To explore the influences of external representations on students' learning of spatial thinking, several data-gathering strategies were used. In summary, these were:

1. initial classroom observations;
2. administration of pre-tests, post-tests and post-post-tests to all participating PM class and VM class students using four spatial tests;
3. administration of pre-tests and post-tests to students in the Control class using four spatial tests; and
4. conduction of teaching experiments with the two classes from School A (the PM class and the VM class). The teaching experiments comprised the implementation of six matched lessons to each class (three based on spatial orientation concepts and three based on spatial visualisation concepts). All lessons were video recorded using two cameras.

#### **7.4 RESEARCH QUESTIONS ADDRESSED**

In order to address the aims and purpose of this research study, two questions were generated from a synthesis of the literature. The main findings of this study are addressed in relation to these research questions.

### 7.4.1 Research Question One

*What influence do different external representations (e.g., physical manipulatives and virtual manipulatives) have on young students' learning of spatial thinking?*

To answer the question pertaining to the influence of different external representations on young students' learning of spatial thinking, the analysis of findings from (a) the spatial testing material, and (b) the teaching experiment are considered.

Initial exploration into the influences of different types of external representations revealed that both physical and virtual manipulatives were beneficial to young students' learning of spatial thinking. Students from the PM class and the VM class exhibited statistically significant improvements in their spatial test scores. These improvements were maintained over a six-month non-treatment period, suggesting that gains made from the use of PM and VM are maintained over time. Furthermore, the results from the spatial tests indicated that students who used external representations (i.e., PM or VM) made greater progress in their spatial thinking than those who did not (i.e., the Control class). These positive gains made by the PM students and VM students evidenced the effectiveness of embodied actions as a contributor to young students' spatial thinking.

However, it seems that the use of virtual manipulatives is more beneficial than the use of physical manipulatives in influencing young students' spatial thinking. This was evident in the larger effect sizes in the VM students' scores from the four spatial tests (i.e., in pairwise comparisons from the pre-test to post-test scores and the pre-test to post-post-test scores in the VM class). These results indicated that the use of VM materials was more effective than the use of PM materials in supporting young students' spatial thinking. As the VM class's effect sizes were larger than the PM class's effect sizes, questions were raised with regard to the necessity of using physical manipulatives to support the development of young students' spatial thinking. This finding also questions whether the use of PM materials is required as a prerequisite before using VM materials in supporting students' spatial thinking, as stated in the literature.

The use of different types of materials (VM and PM) impacted on students' levels of communication. The results of this study suggest that students in the VM class were participating in more communicative procedures and higher levels of communication procedures as compared to PM students. First, the findings indicate that using VM as compared to PM resulted in increased usage and complexity of students' *mathematical words*. This was evidenced through the increased (a) complexity of students' sentence structure in earlier phases of the lesson sequence, and (b) variety and frequency of *special keywords* used by students.

Increased complexity of *mathematical words* resulted in VM students illustrating a greater progress towards *objectification*, applying principles of *saming*, and evidencing the process of *individualisation* and *appropriation*.

Second, VM students utilised a wider range and greater frequency of *visual mediators* in the form of gestures. VM students' increased usage of *iconic* and *metaphoric gestures* was considered as evidence of higher levels of *concretisation*, indicating students' progression towards the abstraction of spatial concepts and additionally towards visual imagery. The complexity of gestures used by the VM students also illustrated the process of *objectification*. The findings from this study further support Sfard's (2009) belief that gestures (as visual mediators) are a crucial component of effective mathematical communication and learning, particularly for young students.

Additionally, when mathematical words and visual mediators align, they can act as an indicator that students are ready for more in-depth learning experiences. VM students' combined increased usage of *mathematical words* and *visual mediators* resulted in more effective communication in the VM class. The symbiotic relationship between and simultaneous use of *mathematical words* and *visual mediators* appeared to enhance students' spatial thinking. These increased forms and instances of communication resulted in a greater frequency of instances of commognitive conflict in the VM class, thus allowing these students' learning of spatial thinking to be rectified or extended. Furthermore, these changes in the VM students' communication influenced further changes to (a) the *routines* attended to by the students, (b) the interaction between teacher and students, and (c) who was leading the discourse.

VM students participating in more communicative functions (e.g., *mathematical words* and *visual mediators*) created greater opportunities for new mathematical discourse to develop. The use of PM appeared to foster students (and the teacher) to adopt *deed routines*, where gestures such as pointing and iconic were used to manipulate the physical materials. Further evidence of *deed routines* was PM students' limited use of *mathematical words* (e.g., "here" and "this one") to explain the narratives of their spatial thinking. In contrast, the increased communicative functions used by the VM class (i.e., more complex sentence structures, increased frequency and variety of special keywords, and use of more complex iconic and metaphoric gestures), appeared to signify their movement towards *exploration routines*. It is surmised that this change further moved VM students' spatial thinking towards visual imagery and mathematical abstraction. Overall, the main influence that different external representations had on students' learning of spatial thinking related to their level of communication.

Additionally, the use of VM promoted increased gestural communication (e.g., iconic and grounding gestures, or “dragging”). It is suggested that this supported students’ development of visual imagery and their progression towards abstraction. The fact that VM students were using these types of gestures more regularly demonstrates a need to extend McNeill’s (1992) gesture classifications to include grounding and dragging gestures, especially when examining the influence of gestures on young students’ learning within a virtual manipulative environment.

#### 7.4.2 Research Question Two

*What changes occur in the teaching and learning of spatial thinking when using different external representations (e.g., physical manipulatives and virtual manipulatives)?*

Findings from this study suggest that the different types of external representations used within a mathematics classroom lesson influenced changes to the teaching and learning process, and in particular changes in the teacher–learner agreement. These changes included the type of scaffolding practices implemented by the teacher. Changes in the teacher–learner agreement occurred due to (a) the unique features embedded within the iPad apps (e.g., multimodal representations and direct real-time feedback), and (b) students’ adopting the use of peer scaffolding.

The unique features embedded in the virtual manipulatives resulted in VM students being in greater control of their learning. These features included (a) multimodal representations, which promoted the simultaneous use of *mathematical words* and *visual mediators*; and (b) direct real-time feedback, which promoted multiple examples and non-examples of the representations. As students adopted greater control of their learning, peer collaboration was promoted as a *routine* of learning. This resulted in a change to who was leading the discourse; sometimes it was the teacher, sometimes it was the iPad, and sometimes it was the students themselves (e.g., peer scaffolding).

Peer scaffolding appeared to permit a transfer of responsibility for the learning and teaching, and empowered both the students and the teacher. Students who adopted the lead role in peer scaffolding evidenced a progression towards *individualisation* by acting as MKO or expert participant. Students acting in this capacity not only had to communicate with themselves, but also to lead the discourse with others. Therefore, students adopting autonomy and leading the discourse appeared crucial to promoting more complex communicative functions, which furthered students’ spatial thinking. A direct result of students’ change in *routine* to become the expert participant in the discourse was a change to the level of the scaffolding practices implemented by the teacher. This in turn influenced changes in the



teacher's communication resulting in her increased variety and usage of *mathematical words* and more complex forms of *visual mediators*.

Increased student communication (i.e., both *mathematical words* and *visual mediators*) influenced the types of scaffolding practices the teacher used. VM students' increased communication evidenced to the teacher that students were progressing their spatial thinking towards higher levels of thinking. These levels included *objectification*, *saming*, *appropriation*, *individualisation*, *visual imagery* and *mathematical abstraction*. This increased communication of the VM students also clearly evidenced areas of students' misconceptions that needed challenging. Thus, in order to maintain this movement towards higher levels of thinking, the teacher was required to progress to using higher levels of scaffolding practices. This movement towards higher scaffolding levels required the teacher to instantaneously draw on her own pedagogical knowledge. Therefore, it is suggested that in order to effectively support and continue this progression, the teacher's pedagogical knowledge needs to be deep and easily accessible.

Furthermore, increased students' communication influenced changes in the teacher's communication. As the VM students' communication increased, the teacher was required to increase her communication (i.e., use more variety of *mathematical words* and more complex *visual mediators*) to maintain the role of MKO in the teacher–learner agreement. It is suggested that this movement is dependent on the depth of content knowledge that the teacher possesses. Therefore, the teacher requires not only deep pedagogical knowledge, but also deep content knowledge in order to continue learning within students' ZPD. As it is assumed that the expert teacher with more chunked memory structures typically has more working space than students, the teacher accessing their deep content knowledge possesses a greater ability to move the discussions along in the ZPD. This memory space allows the teacher to quickly attend to what is occurring and draw on their own mathematical knowledge to respond accordingly

The use of VM influenced changes to the teacher–learner agreement. VM promoted more student autonomy and peer collaboration. As a result, the VM class became more of a place where both the teacher and the learner were working in an equal partnership. They were both acting as equal contributors to the learning. In other words, the teacher and the learner were both operating as MKOs. This equal relationship between the teacher and learner could be considered the epitome of learning within sociocultural theory. Furthermore, for the teacher to continue to act as the MKO and continually expand students' ZPD, her ability to instantaneously access deep content and pedagogical knowledge was a necessity. Overall, different external representations (e.g., PM and VM) changed the teacher–learner agreement. In particular they changed who was acting as a major “contributor to the learning”.

### 7.4.3 Developing a theoretical framework for the teaching and learning of spatial concepts

As the “contributor to the learning” appeared to be a crucial component to students’ learning of spatial thinking, a new model was developed to theorise the influence external representations have on the teaching and learning of spatial thinking.

This new theoretical framework consists of three dimensions that contribute to the teaching and learning of spatial thinking: the teacher, the student, and manipulative type. Both the learners’ and teacher’s contribution to the learning environment can range from no contribution to a major contribution. Within this theoretical framework, it is theorised that the social interactions and classroom culture are at their ultimate when both the teacher and the learners are major contributors. Additionally, classroom culture is at its ultimate when the teacher–learner agreement is on a level playing field, with each (the teacher and students) continually interacting with and progressing the other, *a syncopated dance*. The findings of this study suggest that there is also a hypothesised hierarchy that exists when using physical materials and virtual materials. As evidenced by the findings of this study, the effectiveness of virtual materials is dependent on the inbuilt scaffolding structures and feedback loops they possess. Thus, it is conjectured that the use of these types of virtual manipulatives can result in higher levels of students’ spatial thinking as compared to physical manipulatives. However, it is surmised that reaching these levels is also dependent on the level of communication that occurs in the classroom, and the depth of content and pedagogical knowledge the teacher possesses. If the teacher refuses to or is unable to join in the “syncopated dance”, student learning can be stalled. Figure 7.2 is a depiction of how these three dimensions (teacher, student and physical/virtual manipulatives) interact. The two cubes (TEACHER–STUDENT VM and TEACHER–student PM) represent the two different classes evidenced in the results of this present study.

### Contributors to learning

TEACHER = teacher major contributor

teacher = teacher minor contributor

STUDENT = students major contributor

student = students minor contributor

(Feedback & scaffolding) = materials as a contributor

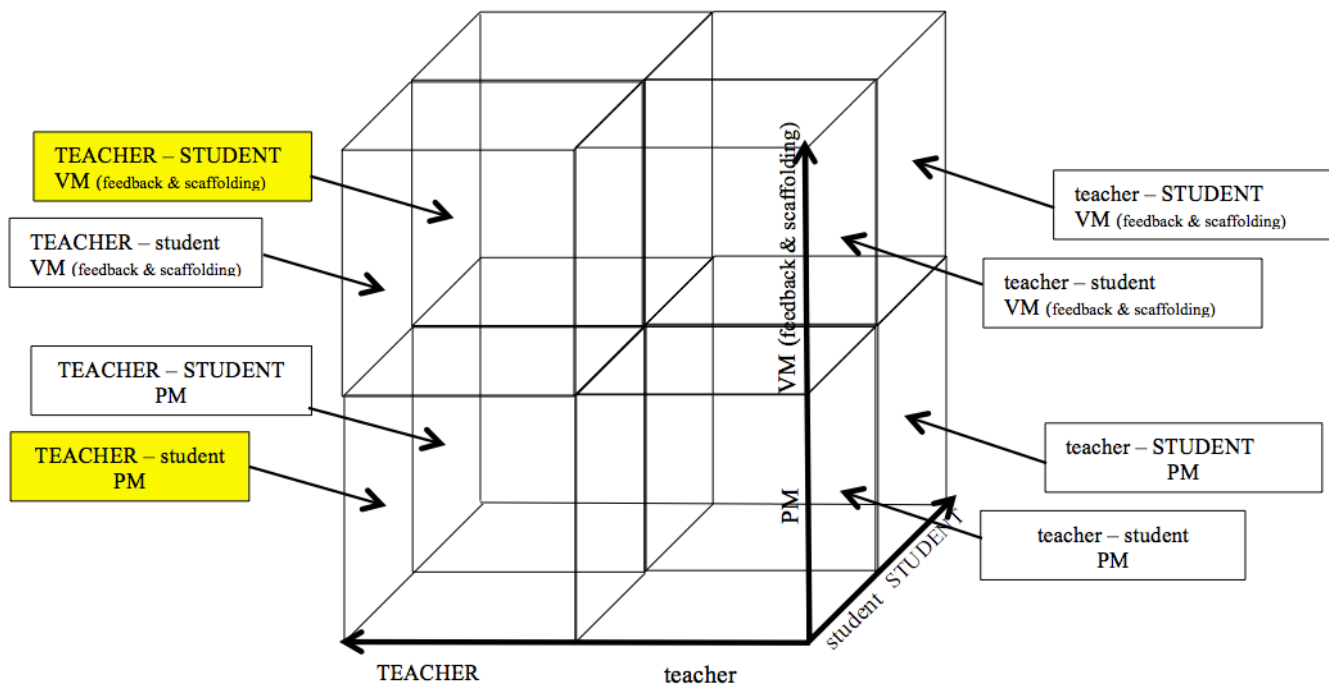

Figure 7.2. Interaction between teacher, student and physical/virtual manipulatives.

The development of this model suggests that there is a hierarchy according to the external representations used and the role (i.e., major or minor) of the contributors to the learning. The premise of this hierarchy is dependent on the following factors.

First, VM are viewed as having a more positive influence on student's learning of spatial thinking than PM. This conjecture is drawn from the findings of this study. VM fostered greater student autonomy and collaboration. Unique features embedded in the VM (e.g., multimodal representations and direct real-time feedback) changed the teacher-learner agreement. In addition, students using VM used increased forms of communication. Therefore, VM were considered as a more optimum form of manipulative to use in young students' learning of spatial thinking.

Second, the proposed hierarchy is based on the major or minor contributions of the teacher and student. To begin with, major contributions are considered superior to minor contributions. A teacher major contribution (e.g., TEACHER) is more desirable than a teacher minor contribution (e.g., teacher); and a student major contribution (e.g., STUDENT) is more beneficial than a student minor contribution (e.g., student). Sociocultural theory is based on the premise that effective learning occurs when both the teacher and the learners are active participants in the

teaching and learning process. A major contribution therefore requires more participation. In this study, greater participation was observed through teacher and students' greater socialisation with others and more interaction with objects. Therefore, major contributions were observable as increased use of communicative functions.

Furthermore, learning situations where the teacher is viewed as the major contributor, while students are minor contributors (e.g., TEACHER–student) are regarded as more effective than learning situations where a teacher is a minor contributor and the student a major contributor (e.g., teacher–STUDENT). As the study was conducted within an early years context, it is assumed that the teacher is more knowledgeable than the students. Sociocultural theory stresses the importance of a MKO to mediate students' understandings. A MKO is required to provide the necessary guidance to students with regard to the social practices and interactions with cultural tools used within the mathematics community. Therefore, a teacher as a major contributor is needed in order to effectively scaffold young students' learning.

Three elements are considered essential for effective scaffolding of students' learning experiences: contingency, fading and transfer of responsibility (Van de Pol et al., 2010). Definitions of fading and transfer of responsibility denote a withdrawal of teacher support. The findings of this study suggest that as young students gain more responsibility for their learning, teacher support is not withdrawn but changed to accommodate higher levels of conceptual thinking. The teacher in the role of MKO is still ensuring that student learning is occurring within their ZPD. Thus, the teacher's scaffolding is contingent on the needs (and exhibited learning) of students. However, as a teacher allows transfer of responsibility of the learning to the young students, she/he still applies contingent scaffolding that is adapted to the current level of students' performance. Thus, in these circumstances, it is conjectured that with young students the teacher cycles through the three elements, and as she/he does so the level of scaffolding and communication moves to higher levels. The effectiveness of this cycling is highly dependent on the teacher's deep content and pedagogical knowledge, as she/he is continually taking over the role of MKO.

Ultimately, the optimum for young students' learning of spatial thinking is where both the teacher and the students are operating as major contributors to the learning (e.g., TEACHER–STUDENT). In these situations, the learning is being drawn from the collective group. Each contributor (i.e., the teacher and the student) is actively participating in the learning, with major contributions evident through their increased communication. From this viewpoint, it could be argued that it is more important to have the teacher–student in equilibrium

with PM (i.e., TEACHER–STUDENT PM) than it is to have the teacher as the major contributor and student as a minor contributor with the VM (i.e., TEACHER–student VM).

Thus, it is hypothesised that the hierarchy of interaction between teacher, student and manipulatives is:

1. teacher–student PM
2. teacher–student VM
3. teacher–STUDENT PM
4. teacher–STUDENT VM
5. TEACHER–student PM
6. TEACHER–student VM
7. TEACHER–STUDENT PM
8. TEACHER–STUDENT VM

The highlighted yellow boxes in Figure 7.2 indicate the conjectured positions of the classes within this study. The use of VM resulted in a learning environment where the teacher and the learner were both major contributors (Level 8). In comparison, the use of PM appeared to foster a learning environment where the teacher was the major contributor and the students were a minor contributor (Level 5).

Overall, the findings of this study and subsequent development of this hierarchical model suggest two major inferences in relation to when the teaching and learning of spatial thinking is optimum.

1. Teaching and learning is optimum when the manipulatives used are a major contributor to the learning (i.e., they contain built-in scaffolding and feedback features).
2. Teaching and learning is optimum when both the teacher and the students are equal major contributors to the classroom discourse (TEACHER–STUDENT).

## **7.5 CONCLUSIONS OF THE STUDY**

Overall, the findings of this study suggest four conclusions related to the two research questions. The first two conclusions relate to students' learning of spatial thinking and the other two relate to the teaching of spatial thinking.

### 7.5.1 Conclusion One

*STUDENT LEARNING – The use of manipulatives (either PM or VM) is crucial to students' learning of spatial thinking.*

The findings of this study suggested that manipulatives are crucial to improving students' learning of spatial thinking. Both PM and VM improved students' scores on spatial testing materials. The benefits gained from using manipulatives in the teaching and learning process were also maintained over a six-month non-treatment period. The embodied actions students engage in while using manipulatives appear to positively influence their spatial thinking.

### 7.5.2 Conclusion Two

*STUDENT LEARNING – The use of virtual manipulatives increased the communicative functions used by students, thus benefiting their spatial thinking.*

The use of virtual manipulatives appeared to act as a more optimum contributor to students' learning. Virtual manipulatives were embedded with unique in-built scaffolding and feedback features. As a result of these features, students using virtual manipulatives participated in more communicative functions. These included an increase in students' use of mathematical words and visual mediators. These increases in communication subsequently influenced a transfer in responsibility for the learning. Students were adopting more control in the teaching and learning process. Furthermore, these gains in students' learning occurred without the use of physical manipulatives. Therefore, the use of VM in the teaching and learning of spatial thinking raised the following questions:

1. *Would the learning in the VM class have been further enhanced if they had initially engaged with PM materials prior to VM materials?*
2. *Are PM materials even necessary in the teaching and learning process?*

### 7.5.3 Conclusion Three

*TEACHING OF SPATIAL THINKING – Teachers need to be able to instantaneously access deep content and pedagogical knowledge in order to maintain the role as MKO and continually contribute to the teaching and learning of spatial thinking.*

The findings of this study suggested that students using VM developed more autonomy in the teaching and learning process. This was evident through students' increased levels of communication and their ability to peer scaffold. In both these instances, the students were driving both the teaching and the learning forward. As the students used more complex

communicative functions, the teacher also needed to adapt and advance the communication functions she used. Not only is the teacher required to have deep content knowledge in order to continue developing students' spatial thinking, but the teacher also needs to instantaneously access this knowledge. As a result of increased communication, students' development and progression towards higher levels of spatial thinking were evident. In these instances, the teacher implemented higher levels of scaffolding. For this to successfully occur the teacher needed to be able to access deep pedagogical knowledge. If a teacher is unable to access deep content and pedagogical knowledge, student learning cannot progress to higher levels.

#### **7.5.4 Conclusion Four**

*TEACHING OF SPATIAL THINKING – Teaching and learning is optimum when both the teacher and the students are major contributors to the classroom discourse (TEACHER–STUDENT).*

The teacher–learner agreement is a major contributor to young students' learning of spatial thinking and subsequently how the teaching occurs. The findings of this study suggest that both the teacher and the student have a role to play in the teaching of spatial thinking. Furthermore, optimum teaching and learning occurs when both teacher and student act as major contributors. As students' communication increased, and instances of peer scaffolding occurred, the teacher needed to accept the changes in the teacher–learner agreement and run with them. Increased student communication influenced increased teacher communication. Similarly, the appearance of peer scaffolding required the teacher to accept students' contributing role in the teaching process and therefore progress to the use of higher levels of scaffolding. However, this continual loop of progression and readjustment was all dependent on the teacher's deep content and pedagogical knowledge. Overall, the culture within a mathematics classroom, in particular the teacher–learner agreement and who is acting as the major contributor to the learning, plays an integral part in allowing deeper levels of spatial thinking to be explored.

#### **7.6 IMPLICATIONS OF THE RESEARCH**

The implications arising from exploring the use and influences of external representations on the teaching and learning of young students' spatial thinking are directed towards both teachers and educational researchers. These recommendations emerged from the conclusions of the study. There are two categories of recommendations: (a) teaching and learning, and (b) research.

### 7.6.1 Implications for teaching and learning

*Manipulatives are important to use with young students during the teaching and learning of spatial thinking.*

A recommendation of this study is that teachers need to use external representations to support young students' learning of spatial thinking. From this study it was evident that both physical and virtual manipulatives had a positive influence on young students' spatial thinking. However, the findings suggest that it may not be necessary to start learning experiences with physical manipulatives in order to advance towards mathematical abstraction, as the process towards abstraction is achievable through the use of virtual manipulatives alone. In fact, the findings of this study suggest that optimum teaching and learning is achieved when the manipulatives used also act as contributors to the learning (i.e., they contain built-in scaffolding and feedback features).

*Young students need to be provided with more opportunities to increase their communicative functions (i.e., use both mathematical words and visual mediators in their spatial thinking).*

Teachers need to be aware of the crucial role of communication in the teaching and learning of spatial thinking. Teachers also need to be aware of the symbiotic relationship that exists between *mathematical words* and *visual mediators*. Increased use of communication (i.e., both mathematical words and visual mediators) acts as a signifier of young students' readiness to move their spatial thinking towards more in-depth learning experiences.

*Teachers need to be able to instantaneously access deep levels of content and pedagogical knowledge to further develop students' spatial thinking.*

The results of the study suggest that as young students' levels of communication increase, the teacher needs to make adjustments and increase her levels of communication. Therefore, teachers need to have deep content knowledge in order to continue in the role of MKO to effectively support students' spatial thinking. Furthermore, with students adopting the role of a MKO through instances of peer scaffolding, the teacher needs to adopt higher levels of scaffolding in order to continually progress young students' spatial thinking to deeper levels of conceptual thinking. Therefore, it is imperative that the teacher is capable of adapting to these changes by possessing the ability to access deep levels of pedagogical knowledge. It is only through the teacher's continual changes to the level of content and pedagogical knowledge that student learning can continue to progress.



*Teachers need to be aware of the importance of allowing students to become major contributors to the teaching and learning process.*

The more students participated in the teaching and learning process, the greater autonomy they experienced. Teachers need to be willing to let students take control of the mathematical discourse. The findings of this study indicated that VM students used increased communicative functions and only when the teacher accepted these changes and made changes herself did more in-depth learning experiences occur.

The use of a hierarchical model is required to examine the influence of the teacher–learner agreement (i.e., both the teacher and the student) when using different external representations. Only by understanding the classroom culture that is optimum in promoting higher levels of spatial thinking can the teacher effectively assist the development of young students’ spatial thinking.

### **7.6.2 Implications for research**

*Qualitative research with young students needs to provide opportunities for students to engage in mathematical discourse.*

It is imperative that qualitative research in spatial thinking occurs as it provides opportunity for rich data from students who engage in mathematical discourse. The findings of the study highlighted the importance of communication in analysing the teaching and learning of spatial thinking. Both verbal and non-verbal forms of communication (i.e., mathematical words and visual mediators) were essential in both the teacher’s and the students’ communication. Furthermore, this study highlighted the significant role of gestures in the communicative functions of both teachers and students. Only by fully understanding the role that both mathematical words and visual mediators (gestures) play in the communication process in teaching and learning will advances in research be gained.

## **7.7 FURTHER RESEARCH CONSIDERATIONS**

There are several issues worth pursuing through further research related to the influence of external representations on the teaching and learning of spatial thinking.

First, the study is bound by the context in which it occurred. A larger study would be beneficial in order to investigate if the findings are applicable to other contexts. A larger study would also attend to issues of generalisability.

Second, a comparative study of the use of physical or virtual manipulatives proved limiting. While the findings from this study suggest that virtual manipulatives promote increased communication of students and greater autonomy, the study raises questions as to the necessity of physical manipulatives in the teaching and learning process. Therefore, a study using various combinations of PM and VM (e.g., PM followed by VM, VM followed by PM, or combined PM and VM) would be beneficial to investigating the role that each manipulative type plays in the teaching and learning process.

Third, further studies into the role of gestures in the communication and learning of spatial thinking are required. The findings from this study suggest that VM fosters students' use of grounding gestures (or "dragging" gestures) and iconic gestures. However, while these gestures appeared to have provided the necessary steps towards visual imagery, further investigation into what role these gestures play in the formulation of frames of reference (e.g., imagining the rotation of the object or imagining yourself rotating) within spatial orientation are required.

Fourth, an extension on this study is warranted to investigate how students transfer their learning from external representations to form internal representations. This study focused on the teacher's and students' use of external representations in the teaching and learning of spatial thinking. To develop a fuller picture of the teaching, and in particular the learning process, further studies into students' internal representations need to occur. Examination of how different external representations influence student creation of internal representations would provide further evidence towards the benefits of each different type of manipulative used in this study.

The findings of this study suggest the importance of peer scaffolding in the process of progressing students' spatial thinking. It would be beneficial to conduct further studies to investigate the role of peer scaffolding, whether there is a hierarchical nature to peer scaffolding practices and how these influence the teaching and learning of spatial thinking. Furthermore, the study could be extended to older students (e.g., secondary year levels) to explore whether these students can fully assume the role of MKO and to investigate the possibility of the teacher becoming obsolete in the teaching and learning process.

## **7.8 LIMITATIONS**

Limitations of this study are discussed in terms of the design of the study. The study focused on a small sample of students from similar disadvantaged schools in south-east Queensland. Therefore, the study was bound by both context and time. The researcher acknowledges that variations would occur based on different settings. To overcome this

limitation, it is necessary to conduct the same study in various other settings to provide transferability of results.

Generalisations drawn from the data are limited. As the study was conducted on a small sample size, and was bound by context and time, generalisations are limited. However, rich descriptive data analysed through a sociocultural perspective of interpreting students' and teacher's communication and interactions provided value to this study. The study also provides a basis for further studies in young students' learning of spatial thinking.

The timeframe of the study proved to be limiting. The teaching experiment was conducted over a two-week period. A longitudinal study would be beneficial to observe the changes in the teacher's and students' communication over greater periods of time. It would be beneficial to observe whether the prolonged use of either type of manipulative yielded different results.

Finally, it is acknowledged that it is not possible to encompass all findings in relation to mathematical discourse and the role of communication in the teaching and learning process. This study tried to address this by using Sfard's (2008) commognitive approach to comprehensively analyse the results of this study. By examining the different discursive characteristics and changes that occurred according to the different type of external representations used (i.e., PM or VM), a thorough examination into the teaching and learning of spatial thinking could occur.

## **7.9 CONCLUDING REMARKS**

Conclusions drawn from this study suggest that two components influence the teaching and learning of students' spatial thinking: the external representations used (PM or VM), and the teaching and learning interactions that occur within the classroom (teacher–learner agreement).

Firstly, different external representations influence various changes in the teaching and learning of spatial thinking. The use of VM appeared to foster increased communicative functions (i.e., more variety and frequency of *mathematical words* and *visual mediators*), and more instances of teacher and student interactions where both were contributing to the teaching and learning process.

Second, progression of students' learning of spatial thinking towards more in-depth learning experiences is dependent on the teacher's ability to access deep levels of content and pedagogical knowledge. It is only as the teacher modifies and changes the content (evident

through increased usage and complexity in communication) and the pedagogy used in scaffolding students' spatial thinking that higher levels of learning can occur.

Finally, a proposed hierarchical model was developed to theorise the contributions of the teacher, the learner and the materials in the teaching and learning process. Conclusions drawn from the findings of the study acknowledge that the teacher plays a pivotal role in enhancing students' learning of spatial thinking. However, this is dependent on their ability to instantaneously access deep content and pedagogical knowledge. Furthermore, the findings suggest that for optimum teaching and learning, there needs to be an equal partnership between both the teacher and the students. New insights have been gained into the role of the teacher and the learner in the teaching and learning process. Findings from this study provide a unique contribution to the role of social and cultural interactions in the form of the teacher–learner agreement. Teachers need to be aware of the role that they play in the teaching and learning of students' spatial thinking and provide opportunities where students can act as contributors to their own learning.

## References

---

- Abdu, R., Schwarz, B., & Mavrikis, M. (2015). Whole-class scaffolding for learning to solve mathematics problems together in a computer-supported environment. *ZDM Mathematics Education, 47*(7), 1163–1178.
- Abedi, J., & Lord, C. (2001). The language factor in mathematics tests. *Applied Measurement in Education, 14*(3), 219–234.
- Adoniou, M., & Qing, Y. (2014). Language, mathematics and English language learners. *Australian Mathematics Teacher, 70*(3), 3–13.
- Ainley, J., Kos, J., & Nicholas, M. (2008). *Participation in science, mathematics and technology in Australian education*. (ACER Research Monographs 4). Retrieved from [http://research.acer.edu.au/acer\\_monographs/4](http://research.acer.edu.au/acer_monographs/4)
- Ainsworth, S. (2006). DeFT: A conceptual framework for considering learning with multiple representations. *Learning and Instruction, 16*(3), 183–198.
- Alagic, M., & Palenz, D. (2006). Teachers explore linear and exponential growth: Spreadsheets as cognitive tools. *Journal of Technology and Teacher Education, 14*(3), 633–649.
- Albro, E., Booth, J., Levine, S., & Massey, C. (2009, October). *Making cognitive development research relevant in the classroom*. Plenary symposium conducted at the VI biennial meeting of the Cognitive Development Society, San Antonio, Texas.
- Aldridge, J. (2005). Among the periodicals: The importance of oral language. *Childhood Education, 81*(3), 177–180.
- Alibali, M. W., & Goldin-Meadow, S. (1993). Gesture-speech mismatch and mechanisms of learning: What the hands reveal about a child's state of mind. *Cognitive Psychology, 25*, 468–523.
- Alibali, M. W., Kita, S., & Young, A. J. (2000). Gesture and the process of speech production: We think, therefore we gesture. *Language and cognitive processes, 15*(6), 593–613.
- Alibali, M. W., & Nathan, M. J. (2012). Embodiment in mathematics teaching and learning: Evidence from learners' and teachers' gestures. *Journal of the Learning Sciences, 21*(2), 247–286.
- Alibali, M. W., Nathan, M. J., Wolfgram, M. S., Church, R. B., Jacobs, S. A., Johnson Martinez, C., & Knuth, E. J. (2014). How teachers link ideas in mathematics instruction using speech and gesture: A corpus analysis. *Cognition and Instruction, 32*(1), 65–100. <http://dx.doi.org/10.1080/07370008.2013.858161>
- Anghileri, J. (1995). Language, arithmetic and the negotiation of meaning. *For the Learning of Mathematics, 21*(3), 10–14.
- Anghileri, J. (2006). Scaffolding practices that enhance mathematics learning. *Journal of Mathematics Teacher Education, 9*(1), 33–52.

- Anghileri, J., & Baron, S. (1998). Playing with the materials of study: Poleidoblocs. *Education 3–13*, 27(2), 57–64.
- Anooshian, L. J., Pascal, V. U., & McCreath, H. (1984). Problem mapping before problem solving: Young children's cognitive maps and search strategies in large-scale environments. *Child Development*, 55, 1820–1834.
- Ansari, D., Donlan, C., Thomas, M. S., Ewing, S. A., Peen, T., & Karmiloff-Smith, A. (2003). What makes counting count? Verbal and visuo-spatial contributions to typical and atypical number development. *Journal of Experimental Child Psychology*, 85(1), 50–62.
- Arcavi, A. (2003). The role of visual representations in the learning of mathematics. *Educational Studies in Mathematics*, 52(3), 215–241.
- Arzarello, F. (2006). Semiosis as a multimodal process. *RELIME. Revista Latinoamericana de Investigación en Matemática Educativa*, 9(1), 267–300.
- Atkinson, P., & Delamont, S. (2006). In the roiling smoke: Qualitative inquiry and contested fields. *International Journal of Qualitative Studies in Education*, 19(6), 747–755.
- Attard, C., & Curry, C. (2012). Exploring the use of iPads to engage young students with mathematics. In *Mathematics education: Expanding horizons (Proceedings of the 35th annual conference of the Mathematics Education Research Group of Australasia)*. Singapore: MERGA.
- Aubrey, C., Godfrey, R., & Dahl, S. (2006). Early mathematics development and later achievement: Further evidence. *Mathematics Education Research Journal*, 18(1), 27–46.
- Australian Curriculum, Assessment and Reporting Authority. (2009). *Annual report 2008–2009*. Retrieved from <http://www.myschool.edu.au>
- Australian Curriculum, Assessment and Reporting Authority. (2014). Australian Curriculum. Retrieved from <http://www.australiancurriculum.edu.au>
- Baker, R. S., Corbett, A. T., & Koedinger, K. R. (2001). Toward a model of learning data representations. In *Proceedings of the 23rd annual conference of the Cognitive Science Society* (pp. 45–50). Mahwah, NJ: Erlbaum.
- Bakhtin, M. M. (1981). *The dialogic imagination: Four essays* (M. Holquist, Ed.). Austin: University of Texas Press.
- Bakker, A., Smit, J., & Wegerif, R. (2015). Scaffolding and dialogic teaching in mathematics education: Introduction and review. *ZDM*, 47(7), 1047–1065.
- Bandura, A. (1997). *Self-efficacy: The exercise of control*. New York, NY: W. H. Freeman.
- Barton, B., Chan, R., King, C., Neville-Barton, P., & Sneddon, J. (2005). EAL undergraduates learning mathematics. *International Journal of Mathematical Education in Science and Technology*, 36(7), 712–729.
- Barwell, R. (2016). Formal and informal mathematical discourses: Bakhtin and Vygotsky, dialogue and dialectic. *Educational Studies in Mathematics*, 92(3), 331–345.

- Basson, A., Krantz, S. G., & Thornton, B. (2006). A new kind of instructional mathematics laboratory. *Problems, Resources, and Issues in Mathematics Undergraduate Studies*, 16(4), 332–348.
- Battista, M. T. (1990). Spatial visualization and gender differences in high school geometry. *Journal for Research in Mathematics Education*, 21(1), 47–60.
- Battista, M. T. (2007). The development of geometric and spatial thinking. In F. Lester (Ed.), *Second handbook of research on mathematics teaching and learning* (pp. 843–908). Reston, VA: National Council of Teachers of Mathematics.
- Battista, M. T. (2008). Development of the Shape Makers geometry microworld. In G. W. Blume & M. K. Heid (Eds.), *Research on technology and the teaching and learning of mathematics* (Vol. 2: Cases and perspectives, pp. 131–156). Charlotte, NC: Information Age.
- Battista, M., & Clements, D. (1992). Geometry and spatial reasoning. In D. Grouws (Ed.), *Handbook of research on mathematics teaching and learning* (pp. 420–464). New York, NY: Macmillan.
- Battista, M. T., & Clements, D. H. (1996). Students' understanding of three-dimensional rectangular arrays of cubes. *Journal for Research in Mathematics Education*, 27, 258–292.
- Bell, C. V., & Pape, S. J. (2012). Scaffolding students' opportunities to learn mathematics through social interactions. *Mathematics Education Research Journal*, 24(4), 423–445.
- Bertolo, D., Dinet, J., & Vivian, R. (2014). Reducing cognitive workload during 3D geometry problem solving with an app on iPad. In *Science and Information Conference 2014* (pp. 896–900). Retrieved from [https://www.researchgate.net/profile/Jerome\\_Dinet/publication/261362194\\_Reducing\\_Cognitive\\_Workload\\_During\\_3D\\_Geometry\\_Problem\\_Solving\\_with\\_an\\_App\\_on\\_iPad/links/0deec5363f3420807d000000.pdf](https://www.researchgate.net/profile/Jerome_Dinet/publication/261362194_Reducing_Cognitive_Workload_During_3D_Geometry_Problem_Solving_with_an_App_on_iPad/links/0deec5363f3420807d000000.pdf)
- Bills, C., & Gray, E. (1999). Pupils' images of teachers' representations. In O. Zaslavsky (Ed.), *Proceedings of the 23rd Conference of the International Group for the Psychology of Mathematics Education* (Vol. 2, pp. 113–120). Haifa, Israel: PME
- Bishop, A. J. (1973). Use of structural apparatus and spatial ability: A possible relationship. *Research in Education*, 9, 43–49.
- Bishop, A. J. (1980). Spatial abilities and mathematics education—A review. *Educational Studies in Mathematics*, 11(3), 257–269.
- Bishop, A. J. (1983). Space and geometry. In R. Lesh & M. Landau (Eds.), *Acquisition of mathematical concepts and processes* (pp. 175–203). New York, NY: Academic Press.
- Blaut, J. M., & Stea, D. (1974). Mapping at the age of three. *Journal of Geography*, 73(7), 5–9.
- Bliss, J., Askew, M., & Macrae, S. (1996). Effective teaching and learning: Scaffolding revisited. *Oxford Review of Education*, 22(1), 37–61.

- Boardman, D. (1990). Graphicacy revisited: Mapping abilities and gender differences. *Educational Review*, 42(1), 57–64.
- Brewer, M. (2000). Research design and issues of validity. In H. Reis & C. Judd (Eds.), *Handbook of research methods in social and personality psychology* (pp. 3–16). Cambridge, UK: Cambridge University Press.
- Broaders, S. C., Cook, S. W., Mitchell, Z., & Goldin-Meadow, S. (2007). Making children gesture brings out implicit knowledge and leads to learning. *Journal of Experimental Psychology: General*, 136(4), 539.
- Bronowski, J. (1947). Mathematics. In D. Thompson & J. Reeves (Eds.), *The quality of education: Methods and purposes in the secondary curriculum* (pp. 179–195). London, England: Frederick Muller.
- Brown, S. E. (2007). Counting blocks or keyboards? A comparative analysis of concrete versus virtual manipulatives in elementary school mathematics concepts. *Online Submission*. Retrieved from <http://files.eric.ed.gov/fulltext/ED499231.pdf>
- Bruce, C. D., McPherson, R., Sabeti, F. M., & Flynn, T. (2011). Revealing significant learning moments with interactive whiteboards in mathematics. *Journal of Educational Computing Research*, 45(4), 433–454.
- Bruce, C., Moss, J., & Ross, J. (2012). *Survey of JK to Grade 2 teachers in Ontario, Canada: Report to the Literacy and Numeracy Secretariat of the Ministry of Education*. Toronto, Canada: Ontario Ministry of Education.
- Bruner, J. S. (1966). *Toward a theory of instruction* (Vol. 59). Cambridge, MA: Harvard University Press.
- Brush, T., & Saye, J. (2002). A summary of research exploring hard and soft scaffolding for teachers and students using a multimedia supported learning environment. *The Journal of Interactive Online Learning*, 1(2), 1–12.
- Cairney, T. H. (2003). Literacy within family life. In N. Hall, J. Larson, & J. Marsh (Eds.), *Early childhood literacy* (pp. 85–98). London, England: Sage.
- Calder, N. S. (2015). Student wonderings: Scaffolding student understanding within student-centred inquiry learning. *ZDM Mathematics Education*, 47(7), 1121–1131.
- Caldwell, B., & Vaughan, T. (2011). *Changing schools in an era of globalization*. New York, NY: Routledge.
- Campbell, P. F., Nishio, M., Smith, T. M., Clark, L. M., Conant, D. L., Rust, A. H., ... Choi, Y. (2014). The relationship between teachers' mathematical content and pedagogical knowledge, teachers' perceptions, and student achievement. *Journal for Research in Mathematics Education*, 45(4), 419–459.
- Candy, P. C. (1989). Constructivism and the study of self-direction in adult learning. *Studies in the Education of Adults*, 21(2), 95–116.
- Carmichael, C., MacDonald, A., & McFarland-Piazza, L. (2014). Predictors of numeracy performance in national testing programs: Insights from the longitudinal study of Australian children. *British Educational Research Journal*, 40(4), 637–659.



- Carraher, D. W., Schliemann, A. D., Brizuela, B. M., & Earnest, D. (2006). Arithmetic and algebra in early mathematics education. *Journal for Research in Mathematics Education*, 37(2), 87–115.
- Carroll, J. B. (1993). *Human cognitive abilities: A survey of factor-analytic studies*. New York, NY: Cambridge University Press.
- Casey, M. B., Nuttall, R. L., & Pezaris, E. (2001). Spatial-mechanical reasoning skills versus mathematics self-confidence as mediators of gender differences on mathematics subtests using cross-national gender-based items. *Journal for Research in Mathematics Education*, 32(1), 28–57.
- Cazden, C. (1979). *Peekaboo as an instructional model: Discourse development at home and at school* (Papers and Reports on Child Language Development, No. 17). Retrieved from <http://files.eric.ed.gov/fulltext/ED191274.pdf>
- Chase, K., & Abrahamson, D. (2015). Reverse-scaffolding algebra: Empirical evaluation of design architecture. *ZDM*, 47(7), 1195–1209.
- Clark, J. M., & Paivio, A. (1991). Dual coding theory and education. *Educational Psychology Review*, 3(3), 149–210.
- Clements, D. H. (1999). Geometric and spatial thinking in young children. In J. V. Copley (Ed.), *Mathematics in the early years* (pp. 66–79). Reston, VA: National Council of Teachers of Mathematics.
- Clements, D. (2001). Mathematics in the preschool. *Teaching Children Mathematics*, 7, 270–275.
- Clements, D. H. (2003). Teaching and learning geometry. In J. Kilpatrick, W. Gary Martin, & D. Schifter (Eds.), *A research companion to the Principles and Standards for School Mathematics* (pp. 151–178). Reston, VA: National Council for Teachers of Mathematics.
- Clements, D. H. (2004). Geometric and spatial thinking in early childhood education. In D. H. Clements, J. Sarama, & A.-M. DiBiase (Eds.), *Engaging young children in mathematics: Standards for early childhood mathematics education* (pp. 267–297). Mahwah, NJ: Lawrence Erlbaum Associates.
- Clements, M. (2012). A historical overview of visualization and visualizing in mathematics education. In *Retirement Symposium of Ted Eisenberg, Israel*. Retrieved from <https://www.cs.bgu.ac.il/~berend/ted-conference/abstracts/clements.docx>
- Clements, D. H., & Battista, M. T. (1992). Geometry and spatial reasoning. In D. A. Grouws (Ed.), *Handbook of research on mathematics teaching and learning* (pp. 420–464). New York, NY: National Council of Teachers of Mathematics/Macmillan Publishing.
- Clements, D. H., & McMillen, S. (1996). Rethinking “concrete” manipulatives. *Teaching Children Mathematics*, 2(5), 270–279.
- Clements, D. H., & Sarama, J. (2002). The role of technology in early childhood learning. *Teaching Children Mathematics*, 8(6), 340–343.

- Clements, D. H., & Sarama, J. (2007). Effects of a preschool mathematics curriculum: Summative research on the Building Blocks project. *Journal for Research in Mathematics Education*, 38(2), 136–163.
- Clements, D. H., & Sarama, J. (2011). Early childhood teacher education: The case of geometry. *Journal of Mathematics Teacher Education*, 14(2), 133–148.
- Clements, D. H., & Sarama, J. (2014). *Learning and teaching early math: The learning trajectories approach* (2nd ed.). New York, NY: Routledge.
- Clements, D. H., Sarama, J., & DiBiase, A.-M. (Eds.). (2004). *Engaging young children in mathematics: Standards for early childhood mathematics education*. Mahwah, NJ: Lawrence Erlbaum Associates..
- Clements, D. H., Swaminathan, S., Hannibal, M. A. Z., & Sarama, J. (1999). Young children's concepts of shape. *Journal for Research in Mathematics Education*, 30(2), 192–212.
- Cleveland, W. S., & McGill, R. (1984). Graphical perception: Theory, experimentation, and application to the development of graphical methods. *Journal of the American Statistical Association*, 79(387), 531–554.
- Cobb, P. (2006). Discursive perspectives on mathematical learning: Commentary on Sfard's and Lerman's chapters. In J. Maasz & W. Schloeglmann (Eds.), *New mathematics education research and practice* (pp. 189–201). Rotterdam, Netherlands: Sense Publishers.
- Cobb, P., Confrey, J., diSessa, A., Lehrer, R., & Schauble, L. (2003). Design experiments in education research. *Educational Researcher*, 32(1), 9–13.
- Cobb, P., Yackel, E., & McClain, K. (Eds.). (2002). *Communicating and symbolizing in mathematics: Perspectives on discourse, tools, and instructional design*. Mahwah, NJ: Lawrence Erlbaum Associates.
- Cobb, P., Yackel, E., & Wood, T. (1992). A constructivist alternative to the representational view of mind in mathematics education. *Journal for Research in Mathematics Education*, 23(1), 2–33.
- Cohen, J. W. (1988). *Statistical power analysis for the behavioural sciences*. Hillsdale, NJ: Lawrence Erlbaum Associates.
- Cohen, L., Manion, L., & Morrison, K. (2007). *Research methods in education* (6th ed.). London, England: Routledge.
- Considine, G., & Zappala, G. (2002). Factors influencing the educational performance of students from disadvantaged backgrounds. In T. Eardley & B. Bradbury (Eds.), *Competing visions: Refereed proceedings of the National Social Policy Conference 2001* (pp. 91–107). Sydney: Social Policy Research Centre, University of New South Wales.
- Cook, S. W., Mitchell, Z., & Goldin-Meadow, S. (2008). Gesturing makes learning last. *Cognition*, 106(2), 1047–1058.
- Coulombe, W. N., & Berenson, S. B. (2001). Representations of patterns and functions: Tools for learning. In A. Cuoco & F. R. Curcio (Eds.), *The roles of representation in school*

- mathematics: 2001 Yearbook of the National Council of Teachers of Mathematics* (pp. 166–172). Reston, VA: National Council of Teachers of Mathematics.
- Creswell, J. (2008). *Research design: Qualitative, quantitative and mixed methods approaches* (3rd ed.). Thousand Oaks, CA: Sage Publications.
- Crotty, M. (1998). *The foundations of social research: Meaning and perspective in the research process*. London, England: Sage.
- Crowley, M. L. (1987). The Van Hiele model of the development of geometric thought. In M. M. Lindquist (Ed.), *Learning and teaching geometry K–12* (pp. 1–16). Reston, VA: National Council of Teachers of Mathematics.
- Cuoco, A. A., & Curcio, F. R. (2001). *The roles of representations in school mathematics: 2001 Yearbook of the National Council of Teachers of Mathematics*. Reston, VA: National Council of Teachers of Mathematics.
- Daraganova, G., & Ainley, J. (2012). Children’s numeracy skills. In B. Maguire & B. Edwards (Eds.), *The longitudinal study of Australian children annual statistical report 2011* (pp. 79–89). Melbourne, Vic: Australian Institute of Family Studies. Retrieved from <http://www.west-info.eu/files/Australia-post-natal1.pdf#page=93>
- Davis, E. A., & Miyake, N. (2004). Explorations of scaffolding in complex classroom systems. *The Journal of the Learning Sciences*, *13*(3), 265–272.
- De Hevia, M. D., & Spelke, E. S. (2010). Number-space mapping in human infants. *Psychological Science*, *21*(5), 653–660.
- Dehaene, S. (1997). *The number sense: How the mind creates mathematics*. New York, NY: Oxford University Press.
- Delgado, A. R., & Prieto, G. (2004). Cognitive mediators and sex-related differences in mathematics. *Intelligence*, *32*(1), 25–32.
- Dempsey, M. (2005). *Introduction to brain gym*. Venture, CA: Educational Kinesiology Foundation.
- Dennison, P. E., & Dennison, G. (1989). *Brain gym handbook: The student guide to brain gym*. Glendale, CA: Educational Kinesiology Foundation.
- Denzin, N., K., & Lincoln, Y. S. (Eds.). (2005). *The Sage handbook of qualitative research*. Thousand Oaks, CA: Sage.
- Department for Education. (2013). *Mathematics programmes of study: Key stages 1 and 2. National curriculum in England*. Retrieved from [https://www.gov.uk/government/uploads/system/uploads/attachment\\_data/file/335158/PRIMARY\\_national\\_curriculum\\_-\\_Mathematics\\_220714.pdf](https://www.gov.uk/government/uploads/system/uploads/attachment_data/file/335158/PRIMARY_national_curriculum_-_Mathematics_220714.pdf)
- Diez-Palomar, J., & Olive, J. (2015). Using dialogic talk to teach mathematics: The case of interactive groups. *ZDM Mathematics Education*, *47*(7), 1299–1312.
- Diezmann, C. M. (2004). The role of operating premises and reasoning paths in upper elementary students’ problem solving. *Journal of Mathematical Behavior*, *23*, 63–73.

- Diezmann, C. M., & McCosker, N. T. (2011). Reading students' representations. *Teaching Children Mathematics*, 18(3), 162–169.
- Dindyal, J. (2015). Geometry in the early years: A commentary. *ZDM*, 47(3), 519–529.
- Dove, A., & Hollenbrands, K. (2014). Teachers' scaffolding of students' learning of geometry while using a dynamic geometry program. *International Journal of Mathematical Education in Science and Technology*, 45(5), 668–681.
- Drickey, N. A. (2000). *A comparison of virtual and physical manipulatives in teaching visualization and spatial reasoning to middle school mathematics students* (Doctoral dissertation). Retrieved from <https://www.editlib.org/p/125430/>
- Driver, R., Asoko, H., Leach, J., Scott, P., & Mortimer, E. (1994). Constructing scientific knowledge in the classroom. *Educational Researcher*, 23(7), 5–12.
- Duval, R. (1999). Representation, vision and visualization: Cognitive functions in mathematical thinking. Basic issues for learning. In *Proceedings of the annual meeting of the North American Chapter of the International Group for the Psychology of Mathematics Education*. Retrieved from <http://files.eric.ed.gov/fulltext/ED466379.pdf>
- Duval, R. (2000). Basic issues for research in mathematics education. In T. Nakahara & M. Koyama (Eds.), *Proceedings of the 24th conference of the International Group for the Psychology of Mathematics Education* (Vol. 1, pp. 55–69). Hiroshima, Japan: Hiroshima University.
- Edmonds-Wathen, C. (2011). Locating the learner: Indigenous language and mathematics education. In J. Clark, B. Kissane, J. Mousley, T. Spencer, & S. Thornton (Eds.), *Mathematics: Traditions and [new] practices. Proceedings of the 34th annual conference of the Mathematics Education Research Group of Australasia and the 23rd biennial conference of the Australian Association of Mathematics Teachers* (pp. 217–225). Adelaide, SA: AAMT & MERGA.
- Edwards, L. D. (2009). Gestures and conceptual integration in mathematical talk. *Educational Studies in Mathematics*, 70(2), 127–141.
- Ehrlich, S. B., Levine, S. C., & Goldin-Meadow, S. (2006). The importance of gesture in children's spatial reasoning. *Developmental Psychology*, 42(6), 1259.
- Ekstrom, R. B., French, J. W., Harmon, H. H., & Derman, D. (1976). *ETS kit of factor-referenced cognitive tests*. Princeton, NJ: Educational Testing Service.
- Elia, I., Gagatsis, A., & van den Heuvel-Panhuizen, M. (2014). The role of gestures in making connections between space and shape aspects and their verbal representations in the early years: Findings from a case study. *Mathematics Education Research Journal*, 26(4), 735–761. <https://doi.org/10.1007/s13394-013-0104-5>
- Emmorey, K., Tversky, B., & Taylor, H. A. (2000). Using space to describe space: Perspective in speech, sign, and gesture. *Spatial Cognition and Computation*, 2, 157–180.
- Epper, R. M., & Baker, E. D. (2009). Technology solutions for developmental math: An overview of current and emerging practices. *Journal of Developmental Education*, 26(2), 4–23.

- Farah, M. J., Hammond, K. M., Levine, D. N., & Calvanio, R. (1988). Visual and spatial mental imagery: Dissociable systems of representation. *Cognitive psychology*, 20(4), 439–462.
- Farmer, G., Verdine, B. N., Lucca, K., Davies, T., Dempsey, R., Hirsh-Pasek, K., & Golinkoff, R. M. (2013, April). *Putting the pieces together: Spatial skills at age 3 predict to spatial and math performance at age 5*. Poster presented at the conference of the Society for Research in Child Development, Seattle, Washington.
- Felton, M. D., & Nathan, M. (2009). Exploring Sfard’s commognitive framework: A review of “Thinking as communicating: Human development, the growth of discourses, and mathematizing”. *Journal for Research in Mathematics Education*, 40(5), 571–576. Retrieved from <http://www.jstor.org/stable/40539357>
- Fennell, F., & Rowan, T. (2001). Representation: An important process for teaching and learning mathematics. *Teaching Children Mathematics*, 7(5), 288–292.
- Field, A. P. (2009). *Discovering statistics using SPSS: And sex and drug and rock ‘n’ roll* (3rd ed.). London, England: Sage.
- Fisher, D., & Frey, N. (2013). *Better learning through structured teaching: A framework for the gradual release of responsibility* (2nd ed.). Alexandria, VA: Association for Supervision and Curriculum Development.
- Flavell, J. H., Everett, B. A., Croft, K., & Flavell, E. R. (1981). Young children’s knowledge about visual perception: Further evidence for the Level 1 – Level 2 distinction. *Developmental Psychology*, 17(1), 99.
- Flevaris, L. M., & Perry, M. (2001). How many do you see? The use of nonspoken representations in first-grade mathematics lessons. *Journal of Educational Psychology*, 93(2), 330.
- Flyvbjerg, B. (2004). Phronetic planning research: Theoretical and methodological reflections. *Planning Theory & Practice*, 5(3), 283–306.
- Flyvbjerg, B. (2006). Five misunderstandings about case-study research. *Qualitative Inquiry*, 12(2), 219–245.
- Fox, J. (2007). International perspectives on early years mathematics. In J. Watson & K. Beswick (Eds.), *Proceedings of the 30<sup>th</sup> annual conference of the Mathematics Education Research Group of Australasia* (Vol. 2, pp. 865–869). Tasmania: MERGA.
- Frank, A. (2005). What do students value in built environment education? *Transactions*, 2(3), 21–29.
- Frigo, T., & Simpson, L. (2001). Research into the numeracy development of Aboriginal students: Implications for NSW K–10 mathematics syllabus. Melbourne, Vic: Australian Council for Educational Research.
- Furner, J. M., & Marinas, C. A. (2011). *Geoboards to Geogebra: Moving from the concrete to the abstract in geometry*. Retrieved from <http://archives.math.utk.edu/ICTCM/VOL23/S088/paper.pdf>

- Gall, M., Gall, J., & Borg, W. (2003). *Educational Research*. Boston, MA: Pearson Education.
- Garrett, L. E. (2010). *The effect of technological representations on developmental mathematics students' understanding of functions* (Doctoral dissertation, Auburn University, Alabama). Retrieved from <https://etd.auburn.edu/bitstream/handle/10415/2288/Lauretta%20Elliott%20Garrett%20Dissertation.pdf?sequence=2>
- Gervasoni, A., Parish, L., Upton, C., Hadden, T., Turkenburg, K., Bevan, K., ... Southwell, J. (2010). Bridging the numeracy gap for students in low SES communities: The power of a whole school approach. In L. Sparrow, B. Kissane, & C. Hurst (Eds.), *Shaping the future of mathematics education, Proceeding of the 33rd annual conference of the Mathematics Education Research Group of Australasia* (pp. 202–209). Fremantle, WA: MERGA.
- Gibbons, T., & Sanderson, G. (2002). Contemporary themes in the research enterprise. *International Education Journal*, 3(4), 1–22.
- Goldenberg, C. (2008). Teaching English language learners: What the research does—and does not—say. *American Educator*, 32, 8–44.
- Goldin, G. A. (1998). Representational systems, learning, and problem solving in mathematics. *The Journal of Mathematical Behavior*, 17(2), 137–165.
- Goldin, G. A. (2003). Representation in school mathematics: A unifying research perspective. In J. Kilpatrick, W. G. Martin, & D. Schifter (Eds.), *A research companion to principles and standards for school mathematics* (pp. 275–285). Reston, VA: National Council of Teachers of Mathematics.
- Goldin, G. A., & Janvier, C. (1998). Representations and the psychology of mathematics education. *The Journal of Mathematical Behavior*, 17(1), 1–4.
- Goldin, G. A., & Kaput, J. J. (1996). A joint perspective on the idea of representation in learning and doing mathematics. In L. P. Steffe, P. Nesher, P. Cobb, G. A. Goldin, & B. Greer (Eds.), *Theories of mathematical learning* (pp. 397–430). Mahwah, NJ: Erlbaum.
- Goldin, G., & Shteingold, N. (2001). Systems of representations and the development of mathematical concepts. In A. A. Cuoco & F. R. Curcio (Eds.), *The roles of representations in school mathematics: 2001 Yearbook of the National Council of Teachers of Mathematics* (pp. 1–23). Reston, VA: National Council of Teachers of Mathematics.
- Goldin-Meadow, S. (2000). Beyond words: The importance of gesture to researchers and learners. *Child Development*, 71(1), 231–239.
- Goldin-Meadow, S. (2003). *Hearing gesture: How our hands help us think*. Cambridge, MA: Harvard University Press.
- Goldin-Meadow, S., Alibali, M. W., & Church, R. B. (1993). Transitions in concept acquisition: Using the hand to read the mind. *Psychological Review*, 100, 279–297.
- Goldin-Meadow, S., Nusbaum, H., Kelly, S. D., & Wagner, S. (2001). Explaining math: Gesturing lightens the load. *Psychological Science*, 12(6), 516–522.

- Gonski, D., Boston, K., Greiner, K., Lawrence, C., Scales, B., & Tannock, P. (2011). *Review of funding for schooling – final report*. Canberra, ACT: Department of Education, Employment and Workplace Relations.
- González, G., & DeJarnette, A. F. (2015). Teachers' and students' negotiation moves when teachers scaffold group work. *Cognition and Instruction, 33*(1), 1–45.
- Goos, M. (2004). Learning mathematics in a classroom community of inquiry. *Journal for Research in Mathematics Education, 35*, 258–291.
- Goos, M., Galbraith, P., Renshaw, P., & Geiger, V. (2003). Perspectives on technology mediated learning in secondary school mathematics classrooms. *The Journal of Mathematical Behavior, 22*(1), 73–89.
- Gough, J. (2007). Conceptual complexity and apparent contradictions in mathematics language. *The Australian Mathematics Teacher, 63*(2), 8–16.
- Granott, N. (2005). Scaffolding dynamically toward change: Previous and new perspectives. *New Ideas in Psychology, 23*(3), 140–151.
- Gray, D. E. (2004). *Doing research in the real world* (1st ed.). London, England: Sage.
- Greenes, C. (1999). Ready to learn: Developing young children's mathematical powers. In J. Copley (Ed.), *Mathematics in the early years* (pp. 39–47). Reston, VA: National Council of Teachers of Mathematics.
- Greeno, J. G., & Hall, R. P. (1997). Practicing representation. *Phi Delta Kappan, 78*(5), 361–67.
- Griffin, S., & Case, R. (1997). Re-thinking the primary school math curriculum: An approach based on cognitive science. *Issues in Education, 3*(1), 1–49.
- Gross, M. (1999). Imposed queries in the school library media center: A descriptive study. *Library & Information Science Research, 21*(4), 501–521.
- Groves, S., Mousley, J., & Forgasz, H. (2006). *Primary numeracy: A mapping, review and analysis of Australian research in numeracy learning at the primary school level*. Melbourne, Vic: Centre for Studies in Mathematics, Science and Environmental Education, Deakin University.
- Guay, R. B., & McDaniel, E. D. (1977). The relationship between mathematics achievement and spatial abilities among elementary school children. *Journal for Research in Mathematics Education, 8*, 211–215.
- Gunderson, E. A., Ramirez, G., Beilock, S. L., & Levine, S. C. (2012). The relation between spatial skill and early number knowledge: The role of the linear number line. *Developmental Psychology, 48*(5), 1229.
- Gutiérrez, Á. (1992). Exploring the links between Van Hiele levels and 3-dimensional geometry. *Structural Topology, 18*, 31–48.
- Gutiérrez, A., Jaime, A., & Fortuny, J. M. (1991). An alternative paradigm to evaluate the acquisition of the Van Hiele levels. *Journal for Research in Mathematics Education, 22*(3), 237–251. doi:10.2307/749076

- Halliday, M. A. K. (1978). *Language as social semiotic*. London, England: Edward Arnold.
- Hallowell, D. A., Okamoto, Y., Romo, L. F., & La Joy, J. R. (2015). First-graders' spatial-mathematical reasoning about plane and solid shapes and their representations. *ZDM*, *47*(3), 363–375.
- Hammond, J., & Gibbon, P. (2001). What is scaffolding? In J. Hammond (Ed.), *Scaffolding: Teaching and learning in language and literacy education* (pp. 1–14). Sydney, NSW: Primary English Teaching Association.
- Healy, L., & Powell, A. (2013). Understanding and overcoming “disadvantage” in learning mathematics. In M. Clements, A. Bishop, C. Keitel, J. Kilpatrick, & F. Leung (Eds.), *Third international handbook of mathematics education. International Handbooks of Education*. New York, NY: Springer.
- Heddens, J. W. (1997). Improving mathematics teaching by using manipulatives. Retrieved from <http://www.fed.cuhk.edu.hk/~flee/mathfor/edumath/9706/13hedden.html>
- Hegarty, M., & Waller, D. (2004). A dissociation between mental rotation and perspective-taking spatial abilities. *Intelligence*, *32*(2), 175–191.
- Hegarty, M., & Waller, D. A. (2005). Individual differences in spatial abilities. In P. Shah & A. Miyake (Eds.), *The Cambridge handbook of visuospatial thinking* (pp. 121–169). New York, NY: Cambridge University Press.
- Henderson, S., & Yeow, J. (2012). *iPads in education: A case study of iPad adoption and use in primary school*. Paper presented at the 45th International Conference on System Sciences, Hawaii. Retrieved from <http://www.computer.org/csdl/proceedings/hicss/2012/4525/00/4525a078.pdf>
- Hennessy, S., Fung, P., & Scanlon, E. (2001). The role of the graphic calculator in mediating graphing activity. *International Journal of Mathematical Education in Science and Technology*, *32*(2), 267–290.
- Heritage, M., & Niemi, D. (2006). Toward a framework for using student mathematical representations as formative assessments. *Educational Assessment*, *11*(3–4), 265–282.
- Herrington, J., Herrington, A., Mantei, J., Olney, I., & Ferry, B. (2009). Using mobile technologies to develop new ways of teaching and learning. In J. Herrington, A. Herrington, J. Mantei, I. Olney, & B. Ferry (Eds.), *New technologies, new pedagogies: Mobile learning in higher education* (pp. 1–14). Wollongong, NSW: University of Wollongong. Retrieved from <http://ro.uow.edu.au/>
- Hershkowitz, R. (1989). Visualization in Geometry--Two Sides of the Coin. *Focus on learning problems in mathematics*, *11*, 61–76.
- Hewitson, R. (2007). Climbing the educational mountain: A metaphor for real culture change for Indigenous students in remote schools. *The Australian Journal of Indigenous Education*, *37*, 6–20.
- Heyd-Metzuyanim, E., & Graven, M. (2016). Between people-pleasing and mathematizing: South African learners' struggle for numeracy. *Educational Studies in Mathematics*, *91*(3), 349–373.



- Highfield, K., & Goodwin, K. (2008). A review of recent research in early mathematics learning and technology. In M. Goos, R. Brown, & K. Makar (Eds.), *Navigating currents and charting directions: Proceedings of the 31st Annual Conference of the Mathematics Education Research Group of Australasia* (pp. 259–264). Adelaide, SA: MERGA.
- Highfield, K., & Mulligan, J. (2007). The role of dynamic interactive technological tools in preschoolers' mathematical patterning. In J. Watson & K. Beswick (Eds.), *Mathematics: Essential research, essential practice: Proceedings of the 30th annual conference of the Mathematics Education Research Group of Australasia* (pp. 372–381). Adelaide, SA: MERGA.
- Hill, H. C., Rowan, B., & Ball, D. L. (2005). Effects of teachers' mathematical knowledge for teaching on student achievement. *American Educational Research Journal*, *42*(2), 371–406.
- Hitchcock, C. H., & Noonan, M. J. (2000). Computer-assisted instruction of early academic skills. *Topics in Early Childhood Special Education*, *20*(3), 145–158.
- Ho, S. Y., & Logan, T. (2013). Students' performance on a symmetry task. In V. Steinle, L. Ball, & C. Bordini (Eds.), *Mathematics education: Yesterday, today and tomorrow: Proceedings of the 36th annual conference of the Mathematics Education Research Group of Australasia* (pp. 747–750). Melbourne, Vic: MERGA.
- Hoffer, A. (1983). Van Hiele-based research. In M. Landau & R. Lesh (Eds.), *Acquisition of mathematics concepts and processes* (pp 205–227), New York, NY: Academic Press.
- Holton, D., & Clarke, D. (2006). Scaffolding and metacognition. *International Journal of Mathematical Education in Science and Technology*, *37*(2), 127–143.
- Holton, D., & Thomas, G. (2001). Mathematical interactions and their influence on learning. In D. Clarke (Ed.), *Perspectives on practice and meaning in mathematics and science classrooms* (pp. 75–104). Dordrecht, Netherlands: Kluwer.
- Hunt, A. W., Nipper, K. L., & Nash, L. E. (2011). Virtual vs. concrete manipulatives in mathematics teacher education: Is one type more effective than the other. *Current Issues in Middle Level Education*, *16*(2), 1–6.
- Huttenlocher, J., Levine, S., & Vevea, J. (1998). Environmental input and cognitive growth: A study using time-period comparisons. *Child Development*, *69*(4), 1012–1029.
- Isaac, S., & Michael, W. B. (1971). *Handbook in research and evaluation*. San Diego, CA: Edits.
- Izsák, A., & Sherin, M. G. (2003). Exploring the use of new representations as a resource for teacher learning. *School Science and Mathematics*, *103*(1), 18–27.
- Jackiw, N., & Sinclair, N. (2009). Sounds and pictures: Dynamism and dualism in dynamic geometry. *ZDM*, *41*(4), 413–426.
- Janvier, C., Girardon, C., & Morand, J. (1993). Mathematical symbols and representations. In P. S. Wilson (Ed.), *Research ideas for the classroom: High school mathematics* (pp. 79–102). Reston, VA: National Council of Teachers of Mathematics.

- Jolly, L., Goos, M., & Smith, A. (2005). Mathematics in school and community in the primary years: Possible effects on choosing engineering as a career. In *4th ASEE/AaeE Global Colloquium on Engineering Education* (p. 1139). Australasian Association of Engineering Education.
- Jones, K. (2000). Providing a foundation for deductive reasoning: Students' interpretations when using dynamic geometry software and their evolving mathematical explanations. *Educational Studies in Mathematics*, *44*(1–2), 55–85.
- Jones, K. (2001). Appendix 8: spatial thinking and visualization. In The Royal Society (Ed.), *Teaching and learning geometry 11–19: Report of a Royal Society/Joint Mathematical Council Working Group* (pp. 55–56). Retrieved from <https://royalsociety.org/topics-policy/publications/2001/teaching-geometry/>
- Jones, K. (2002). Issues in the teaching and learning of geometry. In L. Haggarty (Ed.), *Aspects of teaching secondary mathematics: Perspective on practice* (pp. 121–139). Routledge Falmer. Retrieved from <http://eprints.soton.ac.uk/13588/>
- Jorgensen, R. (2010). *Issues of social equity in access and success in mathematics learning for Indigenous students*. Paper presented at the Teaching mathematics? Make it count: What research shows us about effective mathematics teaching and learning conference, Melbourne. Retrieved from <http://www.acer.edu.au/conference/2010>
- Jorgensen, R., & Lowrie, T. (2012). Digital games for learning mathematics: Possibilities and limitations. In J. Dindyal, L. P. Cheng, & S. F. Ng (Eds.), *Mathematics education: Expanding horizons: Proceedings of the 35th Annual Conference of the Mathematics Education Research Group of Australasia* (pp. 378–384). Singapore: MERGA.
- Kaput, J. J. (1989). Information technologies and affect in mathematical experience. In *Affect and mathematical problem solving* (pp. 89–103). New York, NY: Springer.
- Kaput, J. J. (1992). Technology and mathematics education. In D. Grouws (Ed.), *Handbook of research on mathematics teaching and learning* (pp. 515–556). New York, NY: Macmillan.
- Kaput, J. J. (1998). Representations, inscriptions, descriptions and learning: A kaleidoscope of windows. *The Journal of Mathematical Behavior*, *17*(2), 265–281.
- Kaput, P. (2001). Are we having fun yet? How teachers use manipulatives to teach mathematics. *Educational Studies in Mathematics*, *47*(2), 175–197.
- Kaur, H. (2015). Two aspects of young children's thinking about different types of dynamic triangles: Prototypicality and inclusion. *ZDM*, *47*(3), 407–420.
- Kazak, S., Wegerif, R., & Fujita, T. (2015). Combining scaffolding for content and scaffolding for dialogue to support conceptual breakthroughs in understanding probability. *ZDM Mathematics Education*, *47*(7), 1269–1283.
- Kell, H. J., Lubinski, D., Benbow, C. P., & Steiger, J. H. (2013). Creativity and technical innovation: Spatial ability's unique role. *Psychological Science*, *24*(9), 1831–1836.
- Kendon, A. (1980). Gesticulation and speech: Two aspects of the process of utterance. In M. R. Key (Ed.), *The relationship of verbal and nonverbal communication* (pp. 207–228). The Hague, Netherlands: Mouton.

- Kendon, A. (2000). Language and gesture: Unity or duality? In D. McNeill (Ed.), *Language and gesture* (pp. 47–63). Cambridge, UK: Cambridge University Press.
- Kess, J. F. (1993). *Psycholinguistics*. Amsterdam: John Benjamin Publishing Company.
- Kilpatrick, J., Swafford, J., & Findell, B. (Eds.) (2001). *Adding it up: Helping children learn mathematics*. Washington, DC: National Academy Press.
- Kinach, B. M. (2012). Fostering spatial vs. metric understanding in geometry. *Mathematics Teacher*, 105(7), 534–540.
- Kita, S., & Ozyurek, A. (2003). What does cross-linguistic variation in semantic coordination of speech and gesture reveal? Evidence for an interface representation of spatial thinking and speaking. *Journal of Memory and Language*, 48, 16–32.
- Klinken, E. (2010). Utilising Year Three NAPLAN results to improve Queensland teachers' mathematical pedagogical content knowledge. In L. Sparrow, B. Kissane, & C. Hurst (Eds.), *Shaping the future of mathematics education: Proceedings of the 33rd annual conference of the Mathematics Education Research Group of Australasia* (pp. 578–594). Freemantle, WA: MERGA.
- Kozhevnikov, M., & Hegarty, M. (2001). A dissociation between object manipulation spatial ability and spatial orientation ability. *Memory & Cognition*, 29(5), 745–756.
- Krause, K. L., Bochner, S., Duchesne, S., & McMaugh, A. (2010). *Motivation and engagement: Educational psychology for learning and teaching* (3rd ed.), Melbourne: Centage Learning Australia.
- Krauss, R. M. (1998). Why do we gesture when we speak? *Current Directions in Psychological Science*, 7(2), 54–54.
- Kurdek, L. A., & Sinclair, R. J. (2001). Predicting reading and mathematics achievement in fourth-grade children from kindergarten readiness scores. *Journal of Educational Psychology*, 93(3), 451.
- Lachance, J. A., & Mazzocco, M. M. (2006). A longitudinal analysis of sex differences in math and spatial skills in primary school age children. *Learning and Individual Differences*, 16(3), 195–216.
- Ladel, S., & Kortenkamp, U. (2013). An activity-theoretic approach to multi-touch tools in early maths learning. *The International Journal for Technology in Mathematics Education*, 20(1), 3–8.
- Lange, T., Meaney, T., Riesbeck, E., & Wernberg, A. (2014). Mathematical teaching moments: between instruction and construction. In U. Kortenkamp, B. Brandt, C. Benz, G. Krummheuer, S. Ladel, & R. Vogel (Eds.), *Early mathematics learning: Selected papers of the POEM 2012 conference* (pp. 37–54). New York, NY: Springer.
- Lavergne, J., & Kimura, D. (1987). Hand movement asymmetry during speech: No effect of speaking topic. *Neuropsychologia*, 25, 689–693.
- Leder, G. C. (2012). Mathematics for all? The case for and against national testing. In *12th International Congress on Mathematical Education, Seoul, Korea*. Retrieved from [http://www.icme12.org/upload/submission/1877\\_f.pdf](http://www.icme12.org/upload/submission/1877_f.pdf)

- Leichtenstern, K., André, E., & Vogt, T. (2007). Role assignment via physical mobile interaction techniques in mobile multi-user applications for children. In *European Conference on Ambient Intelligence* (pp. 38–54). Berlin, Germany: Springer.
- Lemke, J. L. (2003). Mathematics in the middle: Measure, picture, gesture, sign, and word. In M. Anderson, A. Saenz-Ludlow, S. Zellweger, & V. V. Cifarelli (Eds.), *Educational perspectives on mathematics as semiosis: From thinking to interpreting to knowing* (pp. 215–234). Brooklyn, NY and Ottawa, Canada: Legas.
- Lerman, S. (2001). A review of research perspectives on mathematics teacher education. In F. L. Lin & T. J. Cooney (Eds.), *Making sense of mathematics teacher education* (pp. 33–52). Dordrecht, Netherlands: Springer.
- Lewis Presser, A., Clements, M., Ginsburg, H., & Ertle, B. (2015). Big math for little kids: The effectiveness of a preschool and kindergarten mathematics curriculum. *Early Education and Development, 26*(3), 399–426.  
<http://dx.doi.org/10.1080/10409289.2015.994451>
- Lieberman, D. A., Fisk, M. C., & Biely, E. (2009). Digital games for young children ages three to six: From research to design. *Computers in the Schools, 26*(4), 299–313.
- Lincoln, Y., & Guba, E. (1985). *Naturalistic inquiry*. Beverly Hills, CA: Sage.
- Linn, M. C., & Petersen, A. C. (1985). Emergence and characterization of sex differences in spatial ability: A meta-analysis. *Child Development, 56*, 1479–1498.
- Lowrie, T. (2002a). Making connections between simulated and “real” worlds: Young children interpreting computer representations. In B. Barton, K. C. Irwin, M. Pfannkuch, & M. O. J. Thomas (Eds.), *Mathematics education in the South Pacific: Proceedings of the 25th annual conference of the Mathematics Education Research Group of Australasia, Auckland* (pp. 441–448). Sydney: MERGA.
- Lowrie, T. (2002b). Visual and spatial reasoning: Young children playing computers. In D. Edge & B. H. Yeaps (Eds.), *Mathematics education for a knowledge-based era: Proceedings of the 2nd East Asia regional conference on mathematics education, Singapore* (Vol. 2, pp. 440–446). Singapore: National Institute of Education.
- Lowrie, T., & Diezmann, C. M. (2007). Solving graphics problems: Student performance in junior grades. *The Journal of Educational Research, 100*(6), 369–378.
- Lowrie, T., Jorgensen, R., & Logan, T. (2012). Mathematics experiences with digital games: Gender, geographic location and preference. In T. Y. Tso (Ed.), *Opportunities to learn in mathematics education: Proceedings of the 36th International Group for the Psychology of Mathematics Education conference* (Vol. 3, pp. 185–192). Taipei, Taiwan: PME.
- Lowrie, T., Logan, T., & Ramful, A. (2017). Visuospatial training improves elementary students’ mathematics performance. *British Journal of Educational Psychology, 87*(2), 170–186.
- Lowrie, T., Logan, T., & Scriven, B. (2012). Perspectives on geometry and measurement in the Australian Curriculum: Mathematics. In B. Atweh, M. Goos, R. Jorgensen, & D. Siemon (Eds.), *Engaging the Australian National Curriculum: Mathematics – Perspectives from the field* (pp. 71–88). Retrieved from <https://alearningplace.com.au/wp-content/uploads/2016/10/Chapter-4-Lowrie.pdf>

- MacGregor M. (2002). Using words to explain mathematical ideas. *Australian Journal of Language and Literacy*, 25(1), 78–88.
- Mackinlay, J. (1999). Automating the design of graphical presentations of relational information. In S. K. Card, J. D. MacKinlay, & B. Schneiderman (Eds.), *Reading in information visualization: Using vision to think* (pp. 66–81). San Francisco, CA: Morgan Kaufmann.
- Masters, G. (2009). *A shared challenge: Improving literacy, numeracy and science learning in Queensland primary schools*. Retrieved from <http://education.qld.gov.au/mastersreview/pdfs/final-report-masters.pdf>.
- Matthews, A. (1996). Linguistic Development. Retrieved from: <http://citeseerx.ist.psu.edu/viewdoc/download?doi=10.1.1.132.9673&rep=rep1&type=pdf>
- Mayer, R. E. (2002). Multimedia learning. *Psychology of Learning and Motivation*, 41, 85–139
- Mayer, R. E. (2005). Cognitive theory of multimedia learning. In R. E. Mayer (Ed.), *The Cambridge handbook of multimedia learning* (pp. 31–48). New York, NY: Cambridge University Press.
- Mayer, R. E., & Anderson, R. B. (1991). Animations need narrations: An experimental test of the dual-coding hypothesis. *Journal of Educational Psychology*, 83, 484–490.
- Mayer, R. E., & Anderson, R. B. (1992). The instructive animation: Helping students build connections between words and pictures in multimedia learning. *Journal of Educational Psychology*, 84(4), 444–445.
- Mayer, R. E., & Moreno, R. (1998). A split-attention effect in multimedia learning: Evidence for dual processing systems in working memory. *Journal of Educational Psychology*, 90(2), 312–320. <http://dx.doi.org/10.1037/0022-0663.90.2.312>
- Mayer, R. E., & Sims, V. K., (1994). For whom is a picture worth a thousand words? Extensions of a dual-coding theory of multimedia learning. *Journal of Educational Psychology*, 86(3), 389–401. <http://dx.doi.org/10.1037/0022-0663.86.3.389>
- McConney, A., & Perry, L. B. (2010a). Science and mathematics achievement in Australia: The role of school socioeconomic composition in educational equity and effectiveness. *International Journal of Science and Mathematics Education*, 8(3), 429–452.
- McConney, A., & Perry, L. B. (2010b). Socioeconomic status, self-efficacy, and mathematics achievement in Australia: A secondary analysis. *Educational Research for Policy and Practice*, 9(2), 77–91.
- McLeod, S. A. (2007). *Vygotsky – simply psychology*. Retrieved from <http://www.simplypsychology.org/vygotsky.html>
- McNeill, D. (1985). So you think gestures are nonverbal? *Psychological Review*, 92(3), 350–371.
- McNeill, D. (1992). *Hand and mind: What gestures reveal about thought*. Chicago, IL: University of Chicago Press.

- Merriam, S. (1998). *Qualitative research and case study application in education*. San Francisco, CA: Jossey-Bass.
- Merriam, S. B. (2001). Case studies as qualitative research. In C. F. Conrad, J. G. Haworth, & L. R. Lattuca (Eds.), *Qualitative research in higher education: Expanding perspectives*, 191–201. Boston, MA: Pearson.
- Middleton, J. A., & Spanias, P. A. (1999). Motivation for achievement in mathematics: Findings, generalizations, and criticisms of the research. *Journal for Research in Mathematics Education*, 65–88.
- Miller, J. (2014). Young Australian Indigenous students' growing pattern generalisations: The role of gesture when generalising. In J. Anderson, M. Cavanagh, & A. Prescott (Eds.), *Curriculum in focus: Research guided practice: Proceedings of the 35th annual conference of the Mathematics Education Research Group of Australasia* (pp. 461–468). Adelaide, SA: MERGA.
- Miller, J., & Warren, E. (2014). Exploring ESL students' understanding of mathematics in the early years: Factors that make a difference. *Mathematics Education Research Journal* 26(4), 791–810.
- Miller, P. H. (2005). Commentary on: Scaffolding: Constructing and deconstructing development. *New Ideas in Psychology*, 23, 207–211.
- Miura, I. T. (2001). The influence of language on mathematical representations. In A. Cuoco & F. R. Curcio (Eds.), *The roles of representation in school mathematics: 2001 Yearbook of the National Council of Teachers of Mathematics* (pp. 53–62). Reston, VA: National Council of Teachers of Mathematics.
- Moch, P. L. (2001). Manipulatives work! *Educational Forum*, 66, 81–87.
- Moreno, R., & Mayer, R. (2007). Interactive multimodal learning environments. *Educational Psychology Review*, 19(3), 309–326.
- Moreno-Armella, L., Hegedus, S. J., & Kaput, J. J. (2008). From static to dynamic mathematics: Historical and representational perspectives. *Educational Studies in Mathematics*, 68(2), 99–111.
- Morley, P. (2011). Victorian Indigenous children's responses to Mathematics NAPLAN items. In J. Clark, B. Kissane, J. Mousley, T. Spencer, & S. Thornton (Eds.), *Mathematics: Traditions and [new] practices: Proceedings of the 34th annual conference of the Mathematics Education Research Group of Australasia and the 23rd biennial conference of the Australian Association of Mathematics Teachers, Alice Springs* (pp. 523–530). Adelaide, SA: AAMT & MERGA.
- Moschkovich, J. (2007). Using two languages when learning mathematics. *Educational Studies in Mathematics*, 64(2), 121–144.
- Moyer, P. S. (2001). Using representations to explore perimeter and area. *Teaching Children Mathematics*, 8(1), 52–59.
- Moyer, P. S., Bolyard, J. J., & Spikell, M. A. (2002). What are virtual manipulatives? *Teaching Children Mathematics*, 8(6), 372–377.

- Moyer, P. S., Niezgodna, D., & Stanley, J. (2005). Young children's use of virtual manipulatives and other forms of mathematical representations. *Technology-Supported Mathematics Learning Environments*, 671, 17–34.
- Moyer, P. S., Salkind, G., & Bolyard, J. J. (2008). Virtual manipulatives used by K–8 teachers for mathematics instruction: The influence of mathematical, cognitive, and pedagogical fidelity. *Contemporary Issues in Technology and Teacher Education*, 8(3), 202–218.
- Moyer-Packenham, P. S., Shumway, J. F., Bullock, E., Tucker, S. I., Anderson-Pence, K. L., Westenskow, A., ... MacDonald, B. (2015). Young children's learning performance and efficiency when using virtual manipulative mathematics iPad apps. *Journal of Computers in Mathematics & Science Teaching*, 34(1), 41–69.
- Moyer-Packenham, P. S., & Suh, J. M. (2011). Learning mathematics with technology: The influence of virtual manipulatives on difference achievement groups. *Journal of Computers in Mathematics and Science Teaching*, 31(1), 39–59.
- Moyer-Packenham, P. S., & Westenskow, A. (2013). Effects of virtual manipulatives on student achievement and mathematics learning. *International Journal of Virtual & Personal Learning Environments*, 4(3), 35–50.
- Mulligan, J. (2015). Looking within and beyond the geometry curriculum: connecting spatial reasoning to mathematics learning. *ZDM*, 47(3), 511–517.
- Mulligan, J., & Vergnaud, G. (2006). Research on children's early mathematical development. In A. Gutierrez & P. Boero (Eds.), *Handbook of research on the psychology of mathematics education: Past, present and future* (pp. 117–146). Rotterdam, Netherlands: Sense Publishers.
- Murcia, K. (2012). Integrating digital technologies into the contemporary science classroom. In K. C. D. Tan & M. Kim (Eds.), *Issues and challenges in science education research* (pp. 225–243). Dordrecht, Netherlands: Springer. <https://doi.org/10.1007/978-94-007-3980-2>
- Murcia, K. (2014). Interactive and multimodal pedagogy: A case study of how teachers and students use interactive whiteboard technology in primary science. *Australian Journal of Education*, 58(1), 74–88.
- Murray, C. (2010). *A mobile journey into apps for learning*. Retrieved from <http://www.slav.schools.net.au/fyi/spring2010/murray.pdf>
- Myhill, D., & Warren, P. (2005). Scaffolds or straitjackets? Critical moments in classroom discourse. *Educational Review*, 57(1), 55–69.
- Nassaji, H., & Wells, G. (2000). What's the use of "triadic dialogue"? An investigation of teacher–student interaction. *Applied linguistics*, 21(3), 376–406.
- Nathan, M. J., & Knuth, E. J. (2003). A study of whole classroom mathematical discourse and teacher change. *Cognition and Instruction*, 21(2), 175–207.
- National Center for Educational Statistics. (2013). *NAEP questions*. Retrieved from <http://nces.ed.gov/nationsreportcard/itmrls/search.asp>

- National Council of Teachers of Mathematics. (2000). *Principles and Standards for School Mathematics*. Reston, VA: NCTM.
- National Research Council (US) Committee on Support for Thinking Spatially, & Downs, R. M. (2006). *Learning to think spatially*. Washington, DC: National Academies Press.
- Newcombe, N. S. (1998). Defining the “radical middle”. *Human Development*, 41(3), 210–214.
- Newcombe, N. S. (2010). Picture this: Increasing math and science learning by improving spatial thinking. *American Educator*, 34(2), 29–43.
- Newcombe, N. S., & Frick, A. (2010). Early education for spatial intelligence: Why, what, and how. *Mind, Brain, and Education*, 4(3), 102–111.
- Newcombe, N., & Huttenlocher, J. (1992). Children’s early ability to solve perspective-taking problems. *Developmental Psychology*, 28(4), 635.
- Newcombe, N. S., & Shipley, T. F. (2015). Thinking about spatial thinking: New typology, new assessments. In J. S. Gero (Ed.), *Studying visual and spatial reasoning for design creativity* (pp. 179–192). Dordrecht, The Netherlands: Springer.
- Newcombe, N. S., & Stieff, M. (2012). Six myths about spatial thinking. *International Journal of Science Education*, 34(6), 955–971.
- Newcombe, N. S., Uttal, D. H., & Sauter, M. (2013). Spatial development. *Oxford Handbook of Developmental Psychology*, 1, 564–590.
- Ng, O. (2014). The interplay between language, gestures, and diagrams in bilingual learners’ mathematical communications. In D. Allen, S. Oselete, & P. Lillejdahl (Eds.), *Proceedings of the 38th Conference of the International Group for the Psychology of Mathematics Education* (Vol. 4, pp. 289–296). Vancouver, Canada: PME.
- Ng, O. L. (2016). The interplay between language, gestures, dragging and diagrams in bilingual learners’ mathematical communications. *Educational Studies in Mathematics*, 91(3), 307–326. <https://doi.org/10.1007/s10649-015-9652-9>
- Ng, O. L., & Sinclair, N. (2015). Young children reasoning about symmetry in a dynamic geometry environment. *ZDM*, 47(3), 421–434.
- Novack, M., & Goldin-Meadow, S. (2015). Learning from gesture: How our hands change our minds. *Educational Psychology Review*, 27(3), 405–412.
- Nueman, W. L. (1997). *Social research methods: Qualitative and quantitative approaches*. Boston, MA: Allyn and Bacon.
- Núñez, R. (2004). Do real numbers really move? Language, thought, and gesture: The embodied cognitive foundations of mathematics. In F. Iida, R. Pfeifer, L. Steels, & Y. Kuniyoshi (Eds.), *Embodied artificial intelligence* (pp. 54–73). Berlin, Germany: Springer.
- Nystrand, M., Wu, L. L., Gamoran, A., Zeiser, S., & Long, D. A. (2003). Questions in time: Investigating the structure and dynamics of unfolding classroom discourse. *Discourse Processes*, 35(2), 135–198.



- Office of the Chief Scientist. (2016). *Australia's STEM workforce: Science, technology, engineering and mathematics*. Retrieved from [http://www.chiefscientist.gov.au/wp-content/uploads/Australias-STEM-workforce\\_full-report.pdf](http://www.chiefscientist.gov.au/wp-content/uploads/Australias-STEM-workforce_full-report.pdf).
- O'Halloran, K. L. (2000). Classroom discourse in mathematics: A multisemiotic analysis. *Linguistics and Education, 10*(3), 359–388.
- O'Halloran, K. L. (2003). Educational implications of mathematics as a multisemiotic discourse. In M. Anderson, A. Saenz-Ludlow, S. Zellweger, & V. V. Cifarelli (Eds.), *Educational perspectives on mathematics as semiosis: From thinking to interpreting to knowing* (pp. 185–214). Brooklyn, NY, and Ottawa, Canada: Legas.
- Olkum, S. (2003). Comparing computer versus concrete manipulatives in learning 2D geometry. *The Journal of Computers in Mathematics and Science Teaching, 22*, 43–56.
- Orrill, C. H., & Polly, D. (2014). Supporting mathematical communication through technology. In D. Polly (Ed.), *Common core mathematics standards and implementing digital technologies* (pp. 23–37). Hershey, PA: IGI Global.
- Owens, K. (2015). *Visuospatial reasoning: An ecocultural perspective for space, geometry and measurement education*. New York, NY: Springer.
- Paek, S., Hoffman, D., Saravanos, A., Black, J., & Kinzer, C. (2011). The role of modality in virtual manipulative design. In D. Tan, B. Begole, & W. A. Kellogg (Eds.), *Proceedings of the 2011 annual conference extended abstracts on human factors in computing systems* (pp. 1747–1752). New York, NY: ACM.
- Paivio, A. (1986). *Mental Representations*. New York, NY: Oxford University Press.
- Pape, S. J., & Tchoshanov, M. A. (2001). The role of representation(s) in developing mathematical understanding. *Theory into Practice, 40*(2), 118–127.
- Pazzaglia, F., & Moè, A. (2013). Cognitive styles and mental rotation ability in map learning. *Cognitive Processing, 14*(4), 391–399.
- Pea, R. D. (2004). The social and technological dimensions of scaffolding and related theoretical concepts for learning, education, and human activity. *The Journal of the Learning Sciences, 13*(3), 423–451.
- Pearson, P. D., & Gallagher, M. C. (1983). The instruction of reading comprehension. *Contemporary Educational Psychology, 8*(3), 317–344.
- Perry, B., & Dockett, S. (2004). Mathematics in early childhood education. In B. Perry, G. Anthony, & C. Diezmann (Eds.), *Research in mathematics education Australasia, 2000–2003* (pp. 103–125). Flaxton, Qld: Post Pressed.
- Perry, B., & Dockett, S. (2007). Early childhood mathematics education research: What is needed now? In J. Watson & K. Beswick (Eds.), *Mathematics: Essential research, essential practice: Proceedings of the 30th annual conference of the Mathematics Education Research Group of Australasia* (Vol. 2, pp. 870–874). Adelaide, SA: MERGA.
- Perry, L., & McConney, A. (2010). School socio-economic composition and student outcomes in Australia: Implications for educational policy. *Australian Journal of Education, 54*(1), 72–85.

- Perry, M., Church, R. B., & Goldin-Meadow, S. (1988). Transitional knowledge in the acquisition of concepts. *Cognitive Development*, 3, 359–400.
- Piaget, J., & Inhelder, B. (1967). *The child's conception of space*. London, England: Routledge.
- Pierce, M. & Fontaine, L. M. (2009). Designing vocabulary instruction in mathematics. *The Reading Teacher*, 63(3), 239–243.
- Pittalis, M., & Christou, C. (2010). Types of reasoning in 3D geometry thinking and their relation with spatial ability. *Educational Studies in Mathematics*, 75(2), 191–212.
- Polly, D. (2014). Deepening pre-service teachers' knowledge of technology, pedagogy, and content (TPACK) in an elementary school mathematics methods course. *Journal of Computers in Mathematics and Science Teaching*, 33(2), 233–250.
- Polly, D., McGee, J. R., & Martin, C. S. (2010). Employing technology-rich mathematical tasks in professional development to develop teachers' technological, pedagogical, and content knowledge (TPACK). *Journal of Computers in Mathematics and Science Teaching*, 29(4), 455–472.
- Presmeg, N. C. (1999). On visualization and generalization in mathematics. In *Proceedings of the annual meeting of the North American Chapter of the International Group for the Psychology of Mathematics Education* (pp. 151–155). Columbus, OH: Clearinghouse for Science, Mathematics, and Environmental Education.
- Pressley, M., & McCormick, C. (1995). *Cognition, teaching, and assessment*. New York, NY: HarperCollins.
- Presson, C. C., & Somerville, S. C. (1985). Beyond egocentrism: A new look at the beginnings of spatial representation. In H. M. Wellman (Ed.), *Children's searching: The development of search skill and spatial representation* (pp. 1–26). Hillsdale, NJ: Erlbaum.
- Proctor, R. M., Batur, A. R., & Cooper, T. J. (2002). Integrating concrete and virtual materials in an elementary mathematics classroom: A case study of success with fractions. In *Proceedings of the seventh world conference on computers in education: Australian topics* (Vol. 8, pp. 87–92). Australian Computer Society. Retrieved from <http://eprints.qut.edu.au/27508/1/27508.pdf>
- Pyke, C. L. (2003). The use of symbols, words, and diagrams as indicators of mathematical cognition: A causal model. *Journal of Research in Mathematics Education*, 34(5), 406–432.
- Queensland Curriculum & Assessment Authority. (2014). *NAPLAN 2014 state report: Year 3*. Retrieved from [https://www.qcaa.qld.edu.au/downloads/p\\_10/naplan\\_2014\\_state\\_rep\\_yr3.pdf](https://www.qcaa.qld.edu.au/downloads/p_10/naplan_2014_state_rep_yr3.pdf)
- Queensland Department of Education and Training. (2016). *The planning for the process of learning*. Retrieved from <http://education.qld.gov.au/staff/learning/diversity/teaching/planning.html>

- Radford, L., Schubring, G., & Seeger, F. (2011). Signifying and meaning-making in mathematical thinking, teaching, and learning. *Educational Studies in Mathematics*, 77(2–3), 149–156.
- Rasmussen, C., & Bisanz, J. (2005). Representation and working memory in early arithmetic. *Journal of Experimental Child Psychology*, 91(2), 137–157.
- Rauscher, F. H., Krauss, R. M., & Chen, Y. (1996). Gesture, speech, and lexical access: The role of lexical movements in speech production. *Psychological Science*, 7(4), 226–231.
- Reimer, K., & Moyer, P. S. (2005). Third-graders learn about fractions using virtual manipulatives: A classroom study. *Journal of Computers in Mathematics and Science Teaching*, 24(1), 5–25.
- Renninger, K. A., & Granott, N. (2005). The process of scaffolding in learning and development. *New Ideas in Psychology*, 23(3), 111–114.
- Renninger, K. A., Ray, L. S., Luft, I., & Newton, E. L. (2005). Coding online content-informed scaffolding of mathematical thinking. *New Ideas in Psychology*, 23, 152–165.
- Riconscente, M. M. (2013). Results from a controlled study of the iPad fractions game Motion Math. *Games and Culture*, 8(4), 186–214.
- Riordain, M., & O'Donoghue, J. (2009). The relationship between performance on mathematical word problems and language proficiency for students learning through the medium of Irish. *Educational Studies in Mathematics*, 71, 43–64.
- Rivera, F. (2011). *Toward a visually-oriented school mathematics curriculum*. New York, NY: Springer.
- Rosen, D., & Hoffman, J. (2009). Integrating concrete and virtual manipulatives in early childhood mathematics. *Young Children*, 64(3), 26–33.
- Roth, W. M., & Radford, L. (2011). *A cultural-historical perspective on mathematics teaching and learning*. Rotterdam, Netherlands: Sense Publishers.
- Roth, W. M., & Thom, J. S. (2009). Bodily experience and mathematical conceptions: From classical views to a phenomenological reconceptualization. *Educational Studies in Mathematics*, 70(2), 175–189.
- Ryve, A. (2006). *Approaching mathematical discourse: Two analytical frameworks and their relation to problem solving interactions* (Doctoral dissertation, Mälardalens högskola). Retrieved from <http://www.diva-portal.org/smash/record.jsf?pid=diva2%3A120510&dswid=781>
- Santos-Trigo, M. (2006). On the use of computational tools to promote students' mathematical thinking. *International Journal of Computers for Mathematical Learning*, 11(3), 361–376.
- Sarama, J. (2004). Technology in early childhood mathematics: Building blocks as an innovative technology-based curriculum. In D. H. Clements & J. Sarama (Eds.), *Engaging young children in mathematics: Standards for early mathematics education* (pp. 361–375). Mahwah, NJ: Erlbaum.

- Sarama, J., & Clements, D. H. (2003). Building blocks of early childhood mathematics. *Teaching Children Mathematics*, 9(8), 480.
- Sarama, J., & Clements, D. H. (2009). *Early childhood mathematics education research: Learning trajectories for young children*. New York, NY: Routledge.
- Sarama, J., & Clements, D. H. (2011). Learning trajectories: Foundations for effective, research-based education. In J. Confrey, A. P. Maloney, & K. Nguyen (Eds.), *Learning over time: Learning trajectories in mathematics education*. New York, NY: Information Age Publishing
- Schaal, A. G., Uttall, D. H., Levine, S. C., & Goldin-Meadow, S. (2005, May). *Children's gestures provide insight into their representations of space*. Poster presented at the annual meeting of the Midwestern Psychological Association, Chicago.
- Schleicher, A. (2008). Seeing school systems through the prism of PISA. In A. Luke, K. Weir, & A. Woods, (Eds.), *Development of a set of principles to guide a P-12 syllabus framework*. Brisbane: Queensland Studies Authority.
- Schleppegrell, M. J. (2007). The linguistic challenges of mathematics teaching and learning: A research review. *Reading & Writing Quarterly*, 23(2), 139–159.
- Schwandt, T. A. (1994). Constructive, interpretive approaches to human inquiry. In N. K. Denzin & Y. S. Lincoln (Eds.), *Handbook of qualitative research*. Thousand Oaks, CA: Sage.
- Schwandt, T. A. (2000). Three epistemological stances for qualitative inquiry. In N. K. Denzin & Y. S. Lincoln (Eds.), *Handbook of qualitative research* (2nd ed., pp. 189–213). London, England: Sage.
- Seidman, I. (2012). *Interviewing as qualitative research: A guide for researchers in education and the social sciences* (4th ed.). New York, NY: Teachers College Press.
- Seo, K., & Ginsburg, H. P. (2004). What is developmentally appropriate in early childhood mathematics education? Lessons from new research. In D. H. Clements & J. Sarama (Eds.), *Engaging young children in mathematics: Standards for early mathematics education* (pp. 91–104). Mahwah, NJ: Erlbaum.
- Setati, M. (2008). Access to mathematics versus access to the language of power: The struggle in multilingual mathematics classrooms. *South African Journal of Education*, 28(1), 103–116.
- Sfard, A. (1991). On the dual nature of mathematical conceptions: Reflections on processes and objects as different sides of the same coin. *Educational Studies in Mathematics*, 22(1), 1–36.
- Sfard, A. (1998). On two metaphors for learning and the dangers of choosing just one. *Educational Researcher*, 27(2), 4–13.
- Sfard, A. (2000). Steering (dis)course between metaphors and rigor: Using focal analysis to investigate an emergence of mathematical objects. *Journal for Research in Mathematics Education*, 31(3), 296–327. doi:10.2307/749809

- Sfard, A. (2001). Learning mathematics as developing a discourse. In R. Speiser, C. Maher, & C. Walter (Eds.), *Proceedings of 21st conference of PME-NA* (pp. 23–44). Columbus, OH: Clearing House for Science, Mathematics, and Environmental Education.
- Sfard, A. (2002a). The interplay of intimations and implementations: Generating new discourse with new symbolic tools. *Journal of the Learning Sciences*, *11*(2–3), 319–357.
- Sfard, A. (2002b). There is more to discourse than meets the ears: Looking at thinking as communicating to learn more about mathematical learning. *Educational Studies in Mathematics*, *46*(1–3), 13–57. <https://doi.org/10.1023/A:1014097416157>
- Sfard, A. (2006). Participationist discourse in mathematical learning. . In J. Maasz & W. Schloeglmann (Eds.), *New mathematics education research and practice* (pp. 153–170). Rotterdam, Netherlands: Sense Publishers.
- Sfard, A. (2007). When the rules of discourse change, but nobody tells you: Making sense of mathematics learning from a commognitive standpoint. *Journal of the Learning Sciences*, *16*(4), 567–615.
- Sfard, A. (2008). *Thinks as communicating: Human development, the growth of discourses, and mathematizing*. Cambridge, UK: Cambridge University Press.
- Sfard, A. (2009). What’s all the fuss about gestures? A commentary. *Educational Studies in Mathematics*, *70*(2), 191–200.
- Sfard, A. (2012). Introduction: Developing mathematical discourse—Some insights from communicational research. *International Journal of Educational Research*, *51*, 1–9.
- Sfard, A. (2014). Discursive approaches to learning mathematics. In S. Lerman (Ed.), *Encyclopedia of mathematics education* (pp. 186–190). Netherlands: Springer.
- Sfard, A. (2015). Learning, commognition and mathematics. In D. Scott & E. Hargreaves (Eds.), *The Sage handbook of learning* (pp. 129–138). Thousand Oaks, CA: Sage.
- Sfard, A., & Cobb, P. (2014). Research in mathematics education: What can it teach us about human learning? In R. K. Sawyer (Ed.), *The Cambridge handbook of the learning sciences* (pp. 545–563). Cambridge, UK: Cambridge University Press.
- Sfard, A., & Kieran, C. (2001). Cognition as communication: Rethinking learning-by-talking through multi-faceted analysis of students’ mathematical interactions. *Mind, Culture, and Activity*, *8*(1), 42–76.
- Sfard, A., & Lavie, I. (2005). Why cannot children see as the same what grown-ups cannot see as different? Early numerical thinking revisited. *Cognition and Instruction*, *23*(2), 237–309.
- Sfard, A., & McClain, K. (2002). Guest editor’s introduction: Analyzing tools: Perspectives on the role of designed artifacts in mathematics learning. *Journal of the Learning Sciences*, *11*(2–3), 153–161.
- Sfard, A., Neshet, P., Streefland, L., Cobb, P., & Mason, J. (1998). Learning mathematics through conversation: Is it as good as they say? *For the Learning of Mathematics*, *18*(1), 41–51.

- Shadish, W. R., Cook, T. D., & Campbell, D. T. (2002). *Experimental and quasi-experimental designs for general causal inference*. Boston, MA: Houghton Mifflin.
- Shah, P., & Miyake, A. (2005). *The Cambridge handbook of visuospatial thinking*. Cambridge, UK: Cambridge University Press.
- Shaughnessy, J. M., & Burger, W. F. (1985). Spadework prior to deduction in geometry. *The Mathematics Teacher*, 78(6), 419–428.
- Shea, D. L., Lubinski, D., & Benbow, C. P. (2001). Importance of assessing spatial ability in intellectually talented young adolescents: A 20-year longitudinal study. *Journal of Educational Psychology*, 93(3), 604.
- Shenton, A. (2004). Strategies for ensuring trustworthiness in qualitative research projects. *Education for Information*, 22, 63–75.
- Shulman, L. S. (1986). Paradigms and research programs in the study of teaching: A contemporary perspective. In M. C. Wittrock (Ed.), *Handbook of research on teaching* (3rd ed., pp. 3–36). New York, NY: Collier Macmillan.
- Siegel, A. W., & Schadler, M. (1977). The development of young children's spatial representations of their classrooms. *Child Development*, 48, 388–394.
- Siemon, D., Beswick, K., Brady, K., Clark, J., Faragher, R., & Warren, E. (2011). *Teaching mathematics: Foundations to middle years*. Oxford Press.
- Silliman, E. R., & Wilkinson, L. C. (1994). Discourse scaffolds for classroom intervention. In G. P. Wallach & K. G. Butler (Eds.), *Language learning disabilities in school-aged children and adolescents* (2nd ed., pp. 27–52). Boston: Allyn & Bacon.
- Simms, N., & Gentner, D. (2009). Relational language and inhibitory control in the development of analogical ability. *Proceedings of the Second International Conference on Analogy* (pp. 414–422). Retrieved from <http://old.nbu.bg/cogs/analogy09/proceedings/44-T42.pdf>
- Simons, K. D., & Klein, J. D. (2007). The impact of scaffolding and student achievement levels in a problem-based learning environment. *Instructional Science*, 35(1), 41–72.
- Sinclair, N., & Bruce, C. D. (2015). New opportunities in geometry education at the primary school. *ZDM*, 47(3), 319–329.
- Sinclair, N., Bussi, M. G. B., de Villiers, M., Jones, K., Kortenkamp, U., Leung, A., & Owens, K. (2016). Recent research on geometry education: An ICME-13 survey team report. *ZDM*, 48(5), 691–719. doi:10.1007/s11858-016-0796-6
- Sinclair, N., De Freitas, E., & Ferrara, F. (2013). Virtual encounters: The murky and furtive world of mathematical inventiveness. *ZDM*, 45(2), 239–252.
- Sinclair, N., & Moss, J. (2012). The more it changes, the more it becomes the same: The development of the routine of shape identification in dynamic geometry environment. *International Journal of Educational Research*, 51, 28–44.
- Sinclair, N., & Tabaghi, S. G. (2010). Drawing space: Mathematicians' kinetic conceptions of eigenvectors. *Educational Studies in Mathematics*, 74(3), 223–240.

- Sinclair, N., & Yerushalmy, M. (2016). Digital technology in mathematics teaching and learning. In A. Gutiérrez, G. C. Leder, & P. Boero (Eds.), *The second handbook of research on the psychology of mathematics education* (pp. 235–274). Rotterdam, Netherlands: Sense Publishers.
- Singer, M. A., & Goldin-Meadow, S. (2005). Children learn when their teacher's gestures and speech differ. *Psychological Science*, *16*(2), 85–89.
- Smit, J., Van Eerde, H. A. A., & Bakker, A. (2013). A conversation of whole-class scaffolding. *British Educational Research Journal*, *39*(5), 817–834.
- Smith, I. M. (1964). *Spatial ability: Its educational and social significance*. London, England: University of London Press.
- Smith, S. P. (2003). Representation in school mathematics: Children's representations of problems. In J. Kilpatrick, W. G. Martin, & D. Schifter (Eds.), *A research companion to principles and standards for school mathematics* (pp. 263–274). Reston, VA: National Council of Teachers of Mathematics.
- Sowell, E. J. (1989). Effects of manipulative materials in mathematics instruction. *Journal for Research in Mathematics Education*, *20*, 498–505.
- Speer, N. M., & Wagner, J. F. (2009). Knowledge needed by a teacher to provide analytic scaffolding during undergraduate mathematics classroom discussions. *Journal for Research in Mathematics Education*, *40*, 530–562.
- Spencer, P. (2013). iPads: Improving numeracy learning in the early years. In V. Steinle, L. Ball, & C. Bardini (Eds.), *Mathematics education: Yesterday, today and tomorrow: Proceedings of the 36th annual conference of the Mathematics Education Research Group of Australasia* (pp. 610–617). Melbourne, Vic: MERGA.
- Srivastava, P., & Hopwood, N. (2009). A practical iterative framework for qualitative data analysis. *International Journal of Qualitative Methods*, *8*(1), 76–84.
- Stahl, B. C. (2003, December). How we invent what we measure: A constructionist critique of the empiricist bias in IS research. In *Ninth Americas Conference on Information Systems* (pp. 2878–2884). Retrieved from [http://www.tech.dmu.ac.uk/~bstahl/publications/2003\\_constructionism\\_IS\\_research.pdf](http://www.tech.dmu.ac.uk/~bstahl/publications/2003_constructionism_IS_research.pdf)
- Stake, R. (2005). Qualitative case studies. In N. K. Denzin & Y. S. Lincoln (Eds.), *The Sage handbook of qualitative research* (3rd ed., pp. 267–307). Hillsdale, NJ: Erlbaum.
- Stanley, G. (2008). *National numeracy review report*. Barton, ACT: Council of Australian Governments.
- Steffe, L. P., & Thompson, P. W. (2000). Teaching experiments methodology: Underlying principles and essential elements. In R. Lesh & A. E. Kelly (Eds.), *Research design in mathematics and science education* (pp. 267–307). Hillsdale, NJ: Erlbaum.
- Steffe, L. P., & Wiegel, H. G. (1994). Cognitive play and mathematical learning in computer microworlds. *Journal of Research in Childhood Education*, *8*, 117–131.
- Stenberg, D. D. (1992). *Psycholinguistics*. London: Longman.

- Stipek, D. (2013). Mathematics in early childhood education: Revolution or evolution? *Early Education & Development*, 24(4), 431–435.
- Stone, C. A. (1993). What is missing in the metaphor of scaffolding? In E. A. Forman, N. Minick, & C. A. Stone (Eds.), *Contexts for learning: Sociocultural dynamics in children's development* (pp. 169–183). New York, NY: Oxford University Press.
- Stork, F. C. & Widdowson, D. A. (1974). *Learning about linguistics*. London: Hutchinson Ltd
- Stylianou, D., Smith, B., & Kaput, J. J. (2005). Math in motion: Using CBRs to enact functions. *Journal of Computers in Mathematics and Science Teaching*, 24(3), 299–324.
- Suh, J. (2005). *Third graders' mathematics achievement and representation preference using virtual and physical manipulatives for adding fractions and balancing equations* (Doctoral dissertation, George Mason University, Fairfax, Virginia). Retrieved from <http://mason.gmu.edu/~jsuh4/dissertation%20final.pdf>
- Suh, J. M., Moyer, P. S., & Heo, H. J. (2005). Examining technology uses in the classroom: Developing fraction sense using virtual manipulative concept tutorials. *The Journal of Interactive Online Learning*, 3(4), 1–22.
- Sweller, J. (1999). *Instructional design in technical areas*. Camberwell, Vic: ACER Press.
- Sweller, J. (2003). Evolution of human cognitive architecture. In B. Ross (Ed.), *The psychology of learning and motivation* (pp. 215–216). San Diego, CA: Academic Press.
- Tharpe, R. G., & Gallimore, R. (1988). *Rousing minds to life: Teaching, learning and schooling in social context*. Cambridge, UK: Cambridge University Press.
- Thompson, P. W., & Thompson, A. G. (1990). *Salient aspects of experience with concrete manipulatives*. Mexico City: International Group for the Psychology of Mathematics Education.
- Thomson, S., & De Bortoli, L. (2008). *Exploring scientific literacy: How Australia measures up. The PISA 2006 survey of students' scientific, reading and mathematical literacy skills*. Retrieved from <http://research.acer.edu.au/ozpisa/2>
- Thomson, S., De Bortoli, L., Nicholas, M., Hillman, K., & Buckley, S. (2011). *Challenges for Australian education: Results from PISA 2009: The PISA 2009 assessment for students' reading, mathematical and scientific literacy* (PISA national reports). Melbourne, Vic: Australian Council for Educational Research.
- Thomson, S., De Bortoli, L., & Underwood, C. (2017). *PISA 2015 Australia student and achievement data [SPSS]*. Retrieved from <http://research.acer.edu.au/ozpisa/26/>
- Thomson, S., & Fleming, N. (2004). *Summing it up: Mathematics achievement in Australian schools in TIMSS 2002* (TIMSS Australia Monograph no. 6). Melbourne, Vic: Australian Council for Educational Research.
- Thomson, S., & Hillman, K. (2010). *Against the odds: Influences on the post-school success of "low performers"*. Adelaide, SA: National Centre for Vocational Education Research.
- Thomson, S., Hillman, K., & De Bortoli, L. (2012). *A teacher's guide to PISA mathematical literacy*. Melbourne, Vic: Australian Council for Education Research.



- Thomson, S., Hillman, K., Wernert, N., Schmid, M., Buckley, S., & Munene, A. (2012). *Monitoring Australian Year 4 student achievement internationally: TIMSS and PIRLS 2011*. Melbourne, Vic: Australian Council for Educational Research.
- Thomson, S., Wernert, N., O'Grady, E., & Rodrigues, S. (2017). *TIMSS 2015: Reporting Australia's results*. Retrieved from [http://research.acer.edu.au/timss\\_2015/2/](http://research.acer.edu.au/timss_2015/2/)
- Thomson, S., Wernert, N., Underwood, C., & Nicholas, M. (2008). *TIMSS 2007: Taking a closer look at mathematics and science in Australia*. Camberwell, Vic: Australian Council for Educational Research.
- Toptaş, V., Çelik, S., & Karaca, E.T. (2012). Improving 8th grades spatial thinking abilities through a 3D modeling program. *Turkish Online Journal of Educational Technology*, *11*(2), 128–134.
- Trochim, W. (2006). *Qualitative validity*. Retrieved from <http://www.socialresearchmethods.net/kb/qualval.php>
- Tucker, S. I. (2015). *An exploratory study of attributes, affordances, abilities, and distance in children's use of mathematics virtual manipulative iPad apps* (Doctoral dissertation). Retrieved from [https://www.researchgate.net/publication/281410802\\_An\\_Exploratory\\_Study\\_of\\_Attributes\\_Affordances\\_Abilities\\_and\\_Distance\\_in\\_Students'\\_Use\\_of\\_Mathematics\\_Virtual\\_Manipulative\\_iPad\\_Apps?el=1\\_x\\_8&enrichId=rgreq-88f3d53dcb20cee1b112d8e14ed8a420-XXX&enrichSource=Y292ZXJQYWdlOzI5NDA4NzMzMjtBUzozMjgyNzMwNzk4OD E3MjhAMTQ1NTI3NzgwOTM2MA==](https://www.researchgate.net/publication/281410802_An_Exploratory_Study_of_Attributes_Affordances_Abilities_and_Distance_in_Students'_Use_of_Mathematics_Virtual_Manipulative_iPad_Apps?el=1_x_8&enrichId=rgreq-88f3d53dcb20cee1b112d8e14ed8a420-XXX&enrichSource=Y292ZXJQYWdlOzI5NDA4NzMzMjtBUzozMjgyNzMwNzk4OD E3MjhAMTQ1NTI3NzgwOTM2MA==)
- Turner, J. C., Meyer, D. K., Cox, K. E., Logan, C., DiCintio, M., & Thomas, C. T. (1998). Creating contexts for involvement in mathematics. *Journal of Education & Psychology*, *90*, 730–745.
- Tversky, B. (2005). Visuospatial reasoning. In K. J. Holyoak & R. G. Morrison (Eds.), *The Cambridge handbook of thinking and reasoning* (pp. 209–240). Cambridge, UK: Cambridge University Press.
- Uribe-Florez, L., & Wilkins, J. (2010). Elementary school teachers' manipulative use. *School Science and Mathematics*, *110*(7), 363–371.
- Uttal, D. H., & Cohen, C. A. (2012). Spatial thinking and STEM education: When, why and how. *Psychology of Learning and Motivation*, *57*(2), 147–181.
- Uttal, D. H., & O'Doherty, K. (2008). Comprehending and learning from visual representations: A developmental approach. In J. Gilbert, M. Reiner, & M. Nakhleh (Eds.), *Visualization: Theory and practice in science education* (pp. 53–72). New York, NY: Springer.
- Vale, C., Weaven, M., Davies, A., Hooley, N., Davidson, K., & Loton, D. (2013). Growth in literacy and numeracy achievement: Evidence and explanations of a summer slowdown in low socio-economic schools. *The Australian Educational Researcher*, *40*(1), 1–25.
- Valentine, J. C., DuBois, D. L., & Cooper, H. (2004). The relation between self-beliefs and academic achievement: A meta-analytic review. *Educational Psychologist*, *39*(2), 111–133.

- Van de Pol, J., Volman, M., & Beishuizen, J. (2010). Scaffolding in teacher–student interaction: A decade of research. *Educational Psychology Review*, 22(3), 271–296.
- van den Heuvel-Panhuizen, M., Elia, I., & Robitzsch, A. (2015). Kindergartners’ performance in two types of imaginary perspective-taking. *ZDM*, 47(3), 345–362.
- Van Hiele, P. (1986). Characterizing the Van Hiele levels of developing in Geometry. *Journal for Research in Mathematics Education*, 17(1), 31–48.
- Van Lier, L. (1996). *Interaction in the language curriculum: Awareness, autonomy and authenticity*. London, England: Longman.
- Van Merriënboer, J. J., Kirschner, P. A., & Kester, L. (2003). Taking the load off a learner’s mind: Instructional design for complex learning. *Educational Psychologist*, 38(1), 5–13.
- Veel, R. (1999). Language, knowledge and authority in school mathematics. In Fr. Christie (Ed.), *Pedagogy and the shaping of consciousness. Linguistic and social processes* (pp. 185–216). London, England: Continuum.
- Verenikina, I., & Kervin, L. (2011). iPads, digital play and pre-schoolers. *He Kupu*, 2(5), 4–19.
- Vygotsky, L. S. (1978). *Mind in society: The development of higher mental processes*. Cambridge, MA: Harvard University Press.
- Vygotsky, L. S. (1986). *Thought and language* (rev. ed.). Cambridge, MA: MIT Press.
- Wager, A. A. (2013). Practices that support mathematics learning in a play-based classroom. In L. English L. & J. Mulligan (Eds.), *Reconceptualizing early mathematics learning* (pp. 163–181). Dordrecht, Netherlands: Springer.
- Wai, J., Lubinski, D., & Benbow, C. P. (2009). Spatial ability for STEM domains: Aligning over 50 years of cumulative psychological knowledge solidifies its importance. *Journal of Educational Psychology*, 101(4), 817.
- Walker, C. O., Greene, B. A., & Mansell, R. A. (2006). Identification with academics, intrinsic/extrinsic motivation, and self-efficacy as predictors of cognitive engagement. *Learning and Individual Differences*, 16(1), 1–12.
- Walshaw, M. (2016). Lev Vygotsky. In E. de Freitas & M. Walshaw (Eds.), *Alternative theoretical frameworks for mathematics education research* (pp. 11–37). Switzerland: Springer International Publishing.
- Warren, E. (2006). Comparative mathematical language in the elementary school: A longitudinal study. *Educational Studies in Mathematics*, 62(2), 169–189.
- Warren, E. (2009). Early childhood teachers’ professional learning in early algebraic thinking a model that supports new knowledge and pedagogy. *Mathematics Teacher Education and Development*, 10, 30–45.
- Warren, E., & Miller, J. (2013). Enriching the professional learning of early years teachers in disadvantaged contexts: The impact of quality resources and quality professional learning. *Australian Journal of Teacher Education*, 38(7), 91–111.

- Warren, E., & Miller, J. (2015). Supporting English second-language learners in disadvantaged contexts: Learning approaches that promote success in mathematics. *International Journal of Early Years Education*, 23(2), 192–208.
- Warren, E., & Miller, J. (2016). Mathematics at the margins. In *Mathematics at the margins* (pp. 1–13). <https://doi.org/10.1007/978-981-10-0703-3>
- Webb, R. M., Lubinski, D., & Benbow, C. P. (2007). Spatial ability: A neglected dimension in talent searches for intellectually precocious youth. *Journal of Educational Psychology*, 99(2), 397.
- Wilkinson, L. C., & Silliman, E. R. (2000). Classroom language and literacy learning. In M. L. Kamil, P. B. Mosenthal, P. D. Pearson, & R. Barr (Eds.), *Handbook of reading research* (Vol. 3, pp. 337–360). Mahwah, NJ: Erlbaum.
- Williams, S. R., & Baxter, J. A. (1996). Dilemmas of discourse-oriented teaching in one middle school mathematics classroom. *The Elementary School Journal*, 97, 21–38.
- Wilson, M. (2002). Six views of embodied cognition. *Psychonomic Bulletin & Review*, 9(4), 625–636.
- Wood, D., Bruner, J. S., & Ross, G. (1976). The role of tutoring in problem solving. *Journal of Psychology and Psychiatry*, 17(2), 89–100.
- Wood, M. B. (2016). Rituals and right answers: barriers and supports to autonomous activity. *Educational Studies in Mathematics*, 91(3), 327–348.
- Wood, T. (1994). Patterns of interactions and the culture of mathematics classrooms. In S. Lerman (Ed.), *Cultural perspectives on the mathematics classroom* (pp. 149–168). Netherlands: Springer.
- Wraga, M., Shephard, J. M., Church, J. A., Inati, S., & Kosslyn, S. M. (2005). Imagined rotations of self versus objects: An fMRI study. *Neuropsychologia*, 43(9), 1351–1361. <https://doi.org/10.1016/j.neuropsychologia.2004.11.028>
- Yelland, N. (1999). Reconceptualising schooling with technology for the 21st century: Images and reflections. In D. D. Shade (Ed.), *Information technology in childhood education annual* (pp. 39–590). Virginia: AACE.
- Yelland, N. (2000). *Teaching and learning with information and communication technologies (ICT) for numeracy in the early childhood and primary years of schooling*. Melbourne, Vic: Department of Education, Training and Youth Affairs.
- Yelland, N. (2005). The future is now: A review of the literature on the use of computers in early childhood education. *Association for the Advancement of Computing in Education*, 13(3), 201–232.
- Yelland, N., & Masters, J. (2007). Rethinking scaffolding in the information age. *Computers & Education*, 48(3), 362–382.
- Yin, R. K. (1994). Case study research: Design and methods. In M. Miles & M. Huberman (Eds.), *Qualitative data analysis*. Thousand Oaks, CA: Sage.

- Yin, R. (2003). *Case study research: Design and methods* (3rd ed.). Thousand Oaks, CA: Sage.
- Young, R. A., & Collin, A. (2004). Introduction: Constructivism and social constructivism in the career field. *Journal of Vocational Behavior*, *64*, 373–388.
- Zbiek, R. M., Heid, M. K., Blume, G. W., & Dick, T. P. (2007). Research on technology in mathematics education: A perspective of constructs. In F. K. Lester (Ed.), *Second handbook of research on mathematics teaching and learning* (pp. 1169–1207). Charlotte, NC: Information Age Publishing.

# Appendices

## Appendix A Spatial Orientation Test

Name:	Male or Female
-------	----------------

### Spatial Orientation Test

A **Cube** is a 3D shape that has 6 sides. A cube has a top, bottom and four sides. Each of these sides has a different letter, number or symbol on it.

You need to identify if the two blocks can be the **Same** block or are **Different** blocks.

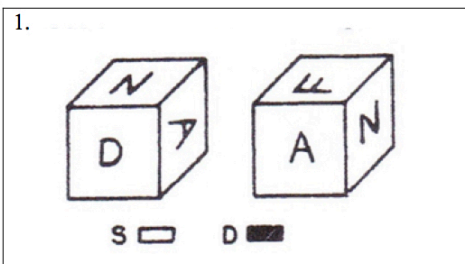

Question 1 is marked **D** because they must be drawings of **Different** cubes.  
If the cube on the left is turned so that the A is upright and facing you at the front, the N would be to the left and hidden from view, not to the right of the A as is shown in the cube on the right. Therefore, the drawings must be of different cubes.

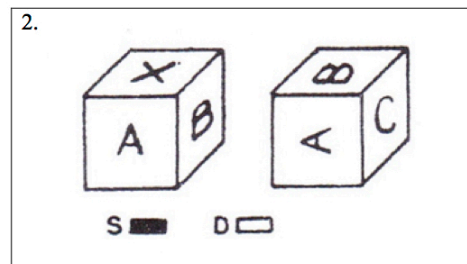

Question 2 is marked **S** because they could be the drawings of the **Same** cube.  
That is, if A is turned on its side the X becomes hidden, the B is now on top, and the C (which was hidden) now appears.  
Therefore, the two drawings could be of the same cube.

It is important to remember that each side of the cube has a different letter, number or symbol. No letter, number or symbol appears on more than one face of a cube. Any letter, number or symbol can be on the hidden face of a cube.

Have a go at the examples below.

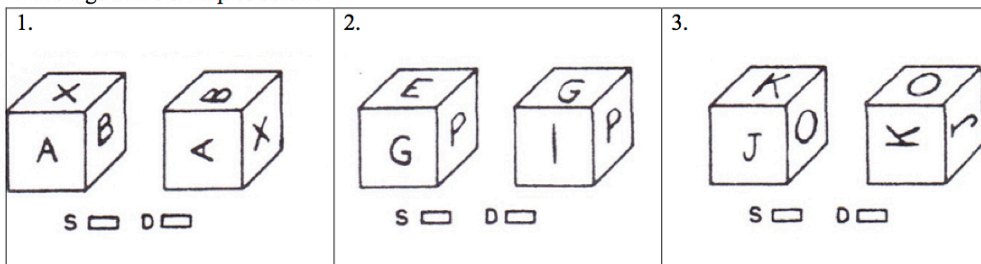

You will have 5 minutes for each of the two parts of this test. Each part has two pages.

When you finish Part 1, **STOP!**



**DO NOT TURN THE PAGE UNTIL YOU ARE ASKED TO DO SO.**

Part 1:	Part 2:	TOTAL:
/21	/21	/42

Name: \_\_\_\_\_

Male or Female

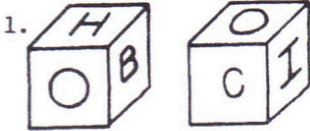
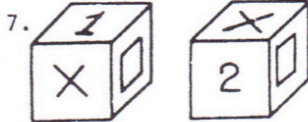
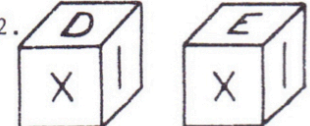
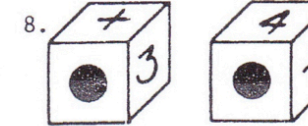
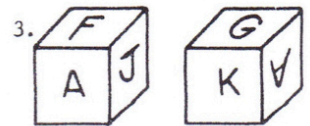
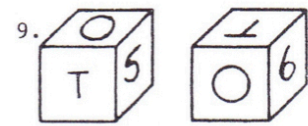
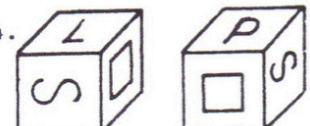
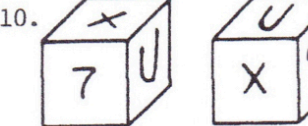
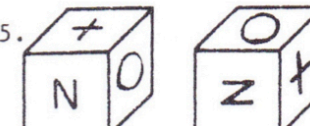
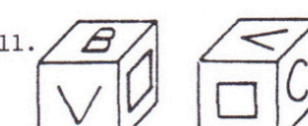
Part 1 (5 minutes)

1.  S <input type="checkbox"/> D <input type="checkbox"/>	7.  S <input type="checkbox"/> D <input type="checkbox"/>
2.  S <input type="checkbox"/> D <input type="checkbox"/>	8.  S <input type="checkbox"/> D <input type="checkbox"/>
3.  S <input type="checkbox"/> D <input type="checkbox"/>	9.  S <input type="checkbox"/> D <input type="checkbox"/>
4.  S <input type="checkbox"/> D <input type="checkbox"/>	10.  S <input type="checkbox"/> D <input type="checkbox"/>
5.  S <input type="checkbox"/> D <input type="checkbox"/>	11.  S <input type="checkbox"/> D <input type="checkbox"/>
6.  S <input type="checkbox"/> D <input type="checkbox"/>	12.  S <input type="checkbox"/> D <input type="checkbox"/>

Name: \_\_\_\_\_

Male or Female

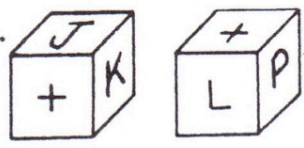
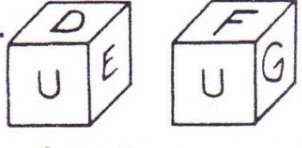
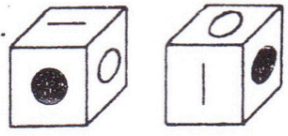
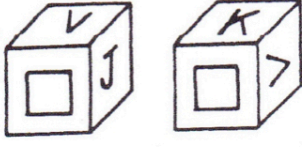
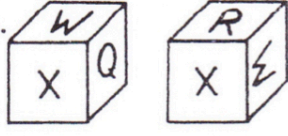
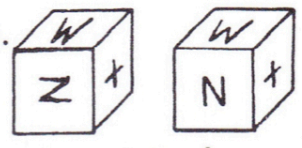
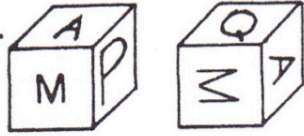
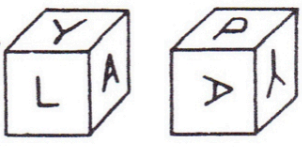
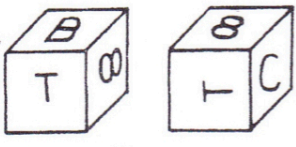
13.  S <input type="checkbox"/> D <input type="checkbox"/>	18.  S <input type="checkbox"/> D <input type="checkbox"/>
14.  S <input type="checkbox"/> D <input type="checkbox"/>	19.  S <input type="checkbox"/> D <input type="checkbox"/>
15.  S <input type="checkbox"/> D <input type="checkbox"/>	20.  S <input type="checkbox"/> D <input type="checkbox"/>
16.  S <input type="checkbox"/> D <input type="checkbox"/>	21.  S <input type="checkbox"/> D <input type="checkbox"/>
17.  S <input type="checkbox"/> D <input type="checkbox"/>	<p style="text-align: center;"><b>Please check all your answers.</b></p>



**STOP!**

**DO NOT GO ON TO THE NEXT PAGE UNTIL ASKED TO DO SO.**

Name: \_\_\_\_\_

Male or Female

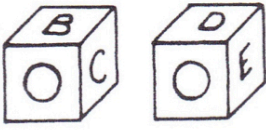
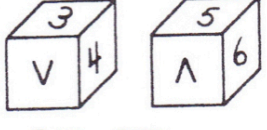
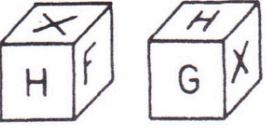
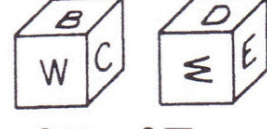
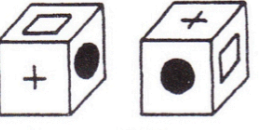
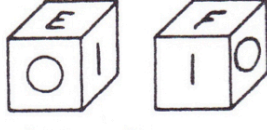
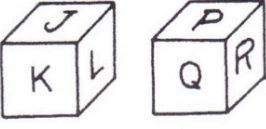
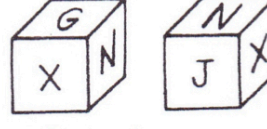
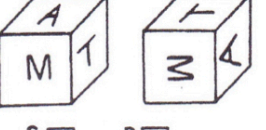
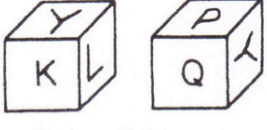
Part 2 (5 minutes)

22.  S <input type="checkbox"/> D <input type="checkbox"/>	28.  S <input type="checkbox"/> D <input type="checkbox"/>
23.  S <input type="checkbox"/> D <input type="checkbox"/>	29.  S <input type="checkbox"/> D <input type="checkbox"/>
24.  S <input type="checkbox"/> D <input type="checkbox"/>	30.  S <input type="checkbox"/> D <input type="checkbox"/>
25.  S <input type="checkbox"/> D <input type="checkbox"/>	31.  S <input type="checkbox"/> D <input type="checkbox"/>
26.  S <input type="checkbox"/> D <input type="checkbox"/>	32.  S <input type="checkbox"/> D <input type="checkbox"/>
27.  S <input type="checkbox"/> D <input type="checkbox"/>	33.  S <input type="checkbox"/> D <input type="checkbox"/>

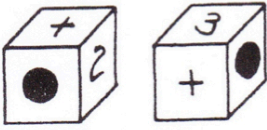
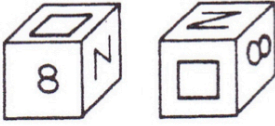
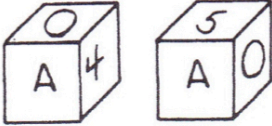
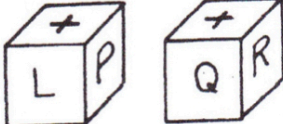
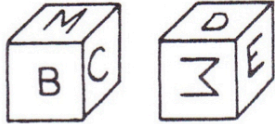
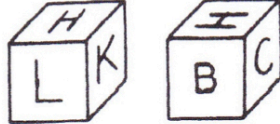
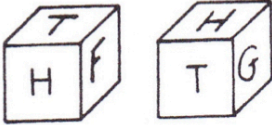
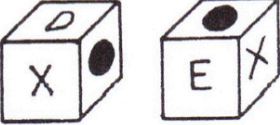
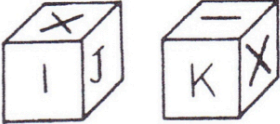

Name:	Male or Female
-------	----------------

<p>34. </p> <p>S <input type="checkbox"/> D <input type="checkbox"/></p>	<p>39. </p> <p>S <input type="checkbox"/> D <input type="checkbox"/></p>
<p>35. </p> <p>S <input type="checkbox"/> D <input type="checkbox"/></p>	<p>40. </p> <p>S <input type="checkbox"/> D <input type="checkbox"/></p>
<p>36. </p> <p>S <input type="checkbox"/> D <input type="checkbox"/></p>	<p>41. </p> <p>S <input type="checkbox"/> D <input type="checkbox"/></p>
<p>37. </p> <p>S <input type="checkbox"/> D <input type="checkbox"/></p>	<p>42. </p> <p>S <input type="checkbox"/> D <input type="checkbox"/></p>
<p>38. </p> <p>S <input type="checkbox"/> D <input type="checkbox"/></p>	<p><b>Please check all your answers.</b></p>

**STOP!**

**DO NOT GO BACK TO PART 1  
YOU HAVE FINISHED THE TEST.**







## Appendix B

### Spatial Visualisation Test 1

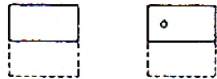
Name:	Male or Female
-------	----------------

## Spatial Visualisation Test 1

In this test you are to imagine the folding and unfolding of a piece of paper. On the left is a picture showing a square piece of paper being folded. The last picture shows where the paper has been punched. Each hole is punched through all the folded bits of paper at that point. On the right are 5 pictures (A, B, C, D, and E) of where the holes will be when the paper is completely unfolded. You need to decide which one of these is correct and colour in that figure. Now try this question.

Question	A	B	C	D	E
					

The figures below show how the paper was folded and why it is the correct answer.

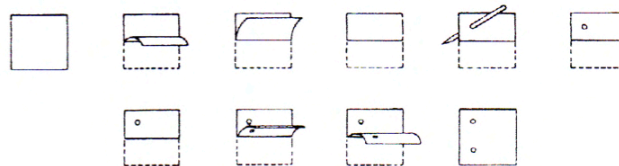

Remember the answer is the figure that shows the positions of the holes when the paper is completely unfolded. You will have 5 minutes for each of the two parts of this test. Each part has 2 pages. When you finish Part 1, **STOP**. Please do not go on to Part 2 until you are asked to do so.











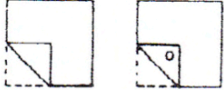





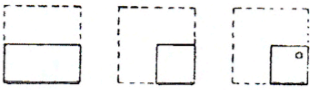





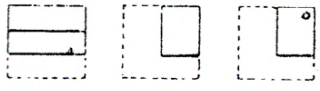







DO NOT TURN THE PAGE UNTIL YOU ARE ASKED TO DO SO.

Part 1:	Part 2:	TOTAL:
/10	/10	/20

Name: \_\_\_\_\_











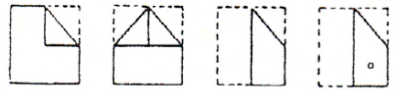





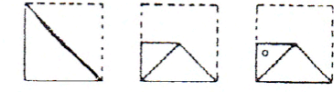





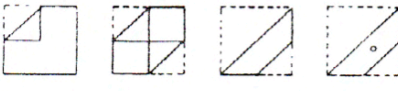







Male or Female

Part 1 (5 minutes)

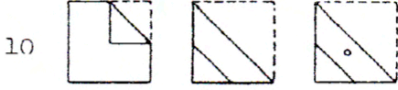
Question	A	B	C	D	E
1 					
2 					
3 					
4 					
5 					

Name: \_\_\_\_\_

Male or Female

Question	A	B	C	D	E
6 					
7 					
8 					
9 					
10 					

















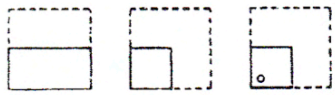





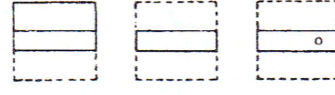







**STOP!**

**DO NOT GO ON TO THE NEXT PAGE UNTIL ASKED TO DO SO.**

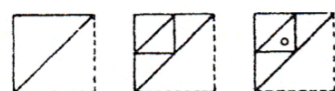
Name: \_\_\_\_\_

Male or Female

Part 2 (5 minutes)

Question	A	B	C	D	E
11 					
12 					
13 					
14 					
15 					

Name:	Male or Female
-------	----------------

Question	A	B	C	D	E
16 					
17 					
18 					
19 					
20 					

**STOP!**

**DO NOT GO BACK TO PART 1**

**YOU HAVE FINISHED THE TEST.**

## Appendix C

### Spatial Visualisation Test 2

Name:	Male or Female
-------	----------------

## Spatial Visualisation Test 2

In this test you are trying to imagine or visualise how a piece of paper can be folded to form some kind of 3D shape. Look at the two drawings below. The drawing on the left is of a piece of paper which can be folded on the dotted lines to form the object drawn on the right. You are to imagine the folding and are to figure out which of the lettered edges on the object are the same as the numbered edges on the piece of paper at the left. Write the letters of the answers in the numbered spaces at the far right.

Now try the practice problem below.  
Numbers 1 and 4 are already correctly marked for you.

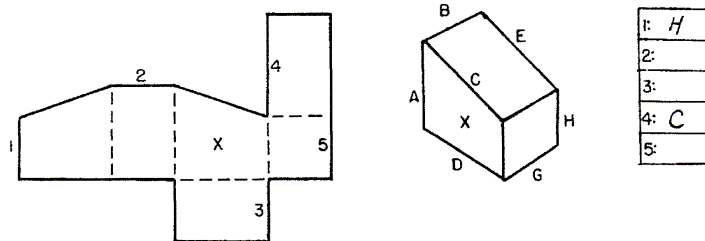

**Remember the paper is always folded so that the X will always be on the outside of the object.**

In the above problem, if the side with edge 1 is folded around to form the back of the object, then edge 1 will be the same as edge H. If the side with edge 5 is folded back, then the side with edge 4 may be folded down so that edge 4 is the same as edge C.

The other answers are as follows: 2 is B; 3 is G; and 5 is H.

**Notice that two of the answers can be the same.**

You will have 10 minutes for each of the two parts of this test. Each part has 2 pages. When you finish Part 1, STOP. Please do not go on to Part 2 until you are asked to do so.

DO NOT TURN THE PAGE UNTIL YOU ARE ASKED TO DO SO.

Part 1:	Part 2:	<b>TOTAL:</b>
/30	/30	/60

Name:	Male or Female
-------	----------------

Part 1 (10 minutes)

1.

**ANSWERS**

1:
2:
3:
4:
5:

2.

**ANSWERS**

1:
2:
3:
4:
5:

3.

**ANSWERS**

1:
2:
3:
4:
5:



Name:

Male or Female

4.

ANSWERS

1:	
2:	
3:	
4:	
5:	

5.

ANSWERS

1:	
2:	
3:	
4:	
5:	

6.

ANSWERS

1:	
2:	
3:	
4:	
5:	

**STOP! DO NOT GO ON TO THE NEXT PAGE UNTIL ASKED TO DO SO.**

Name: \_\_\_\_\_

Male or Female

Part 2 (10 minutes)

7.

**ANSWERS**

1:
2:
3:
4:
5:

8.

**ANSWERS**

1:
2:
3:
4:
5:

9.

**ANSWERS**

1:
2:
3:
4:
5:

Name:

Male or Female

10.

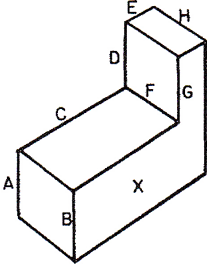
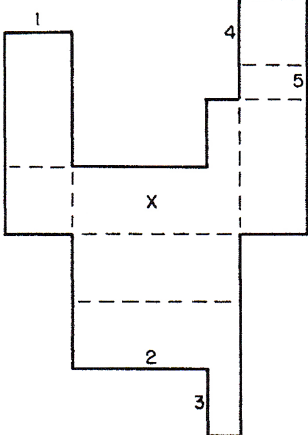

ANSWERS

1:
2:
3:
4:
5:

11.

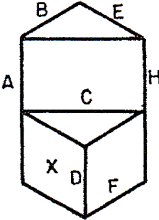
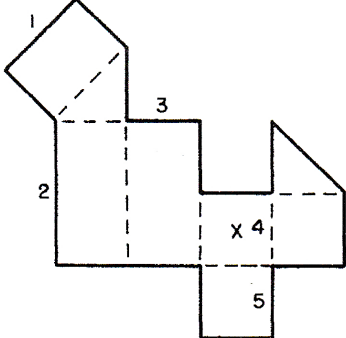

ANSWERS

1:
2:
3:
4:
5:

12.

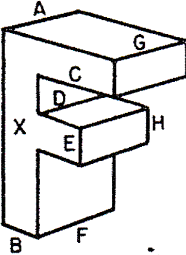
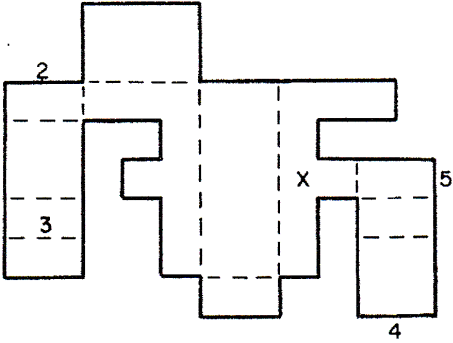

ANSWERS

1:
2:
3:
4:
5:

**STOP! DO NOT GO BACK TP PART 1. YOU ARE FINISHED THE TEST.**



Name:

Male/Female

**Spatial Orientation**

Question  
1(S)

Look at this picture of a cone.



Which one of these shows the top view?

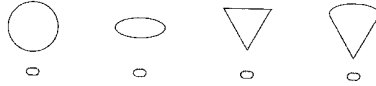

Question  
2(S)

Lee glued 4 white cubes and 2 black cubes together to make this object.

She moved her object.

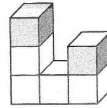

Which one of these is Lee's object?

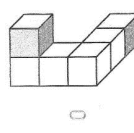
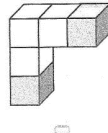
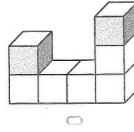
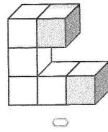

Question  
3(S)

Mel made this model by joining 6 white cubes and 2 grey cubes.

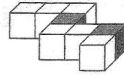

Mel turns her model.

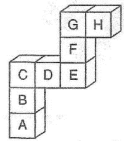

Which two letters show the positions of the grey cubes?

and

Name:

Male/Female

Question  
4(S)

Greg made this solid object by stacking cubes.

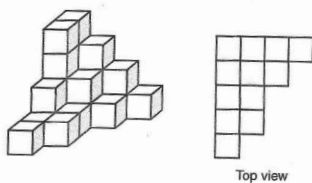

Top view

How many cubes are in Greg's object altogether?

Question  
5(C)

When this mail box is viewed from the **top**  
which one of these pictures shows what it  
would look like?

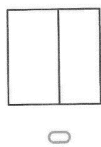
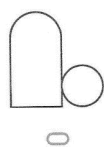
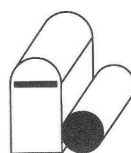

Question  
6(C)

Here are two pictures of the same cube.  
Each face has a different symbol on it.

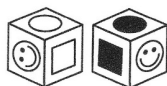

Which face is opposite to the  face?



Name:

Male/Female

Question  
7(C)

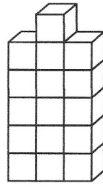

Carl builds this 3D object using 16 cubes.  
He then paints the outside faces of the object including the base.

How many cubes have only 2 faces painted?

Question  
8(C)

What does this building look like when viewed from the point shown by the dot on the ground?

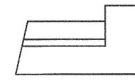
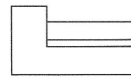
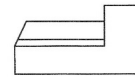
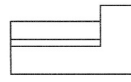
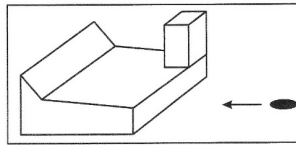

Question  
9(C)

This shape was made using identical cubes.  
A top view of it is shown beside it.

How many cubes are in the shape?

8

10

11

12

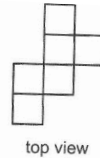
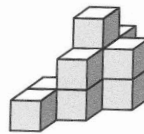

Question  
10(C)

Which one of these could be a top view of the 3D object shown here?

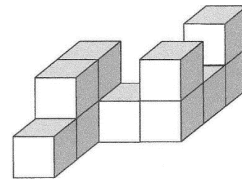
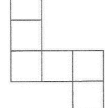
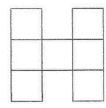
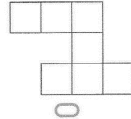
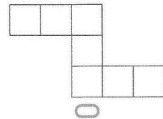

Name:

Male/Female

**Spatial Visualisation (Properties of 3D shapes)**

Question  
11(S)

Which group of shapes shows the faces of this object?

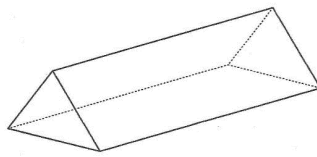

- 
- 
- 
- 

Question  
12(S)

Which one of these shapes has 12 edges?

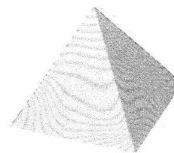
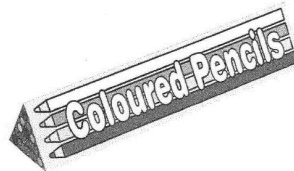
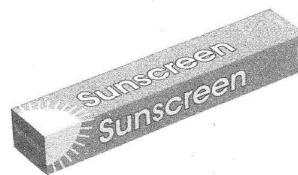

Question  
13(S)

Which of these objects has the **most** edges?





Name:

Male/Female

Question  
14(S)



Which one of these is the net of a cube?

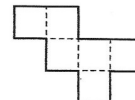
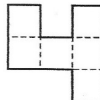
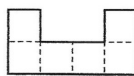
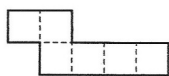

Question  
15(S)

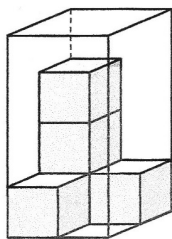

There are 5 cubes in this box.

How many of these cubes can fit in the box altogether?

Question  
16(S)

Each of the pavers in this stack is the same size.

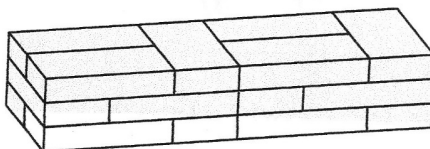

How many pavers are there altogether?

**pavers**

Name:

Male/Female

Question  
17(C)

Narene cut this cube in half.  
Then she put the pieces together to make a new shape.

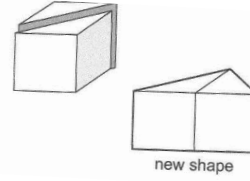

The new shape has  edges and  faces.

Question  
18(C)

A square-based pyramid and a cube have been glued together.

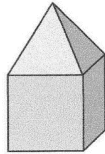

How many **faces** does the new object have?

4



8



9



11



Question  
19(C)

Which 3D shape can be made from this net?

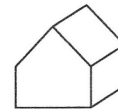
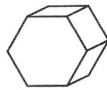
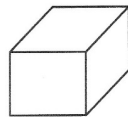
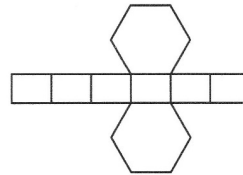

Name:

Male/Female

**Spatial Visualisation (Transformations)**

Question 20(S)

Which face is the same on both sides of the dotted line?

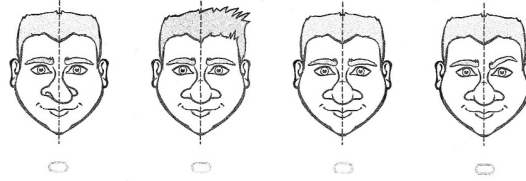

Question 21(S)

Which face is **not** symmetrical?



Question 22(S)

Mandy folds a rectangle of paper along the dotted line and cuts out some shapes.

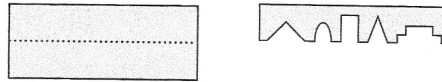

She unfolds the paper and turns it around.

Which of these is Mandy's paper?

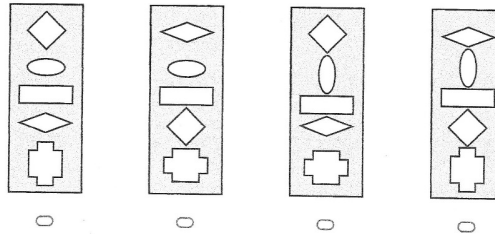

Question 23(S)

Max is making a pattern by turning this shape a **quarter turn clockwise** in each box.

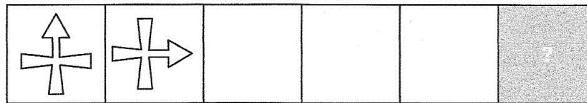

What will the shape in the last box look like?

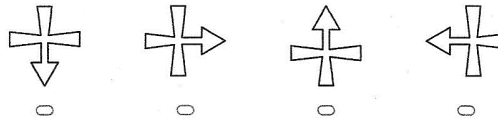

Name:

Male/Female

Question 24(S)

This shoe print was found in the sand.



Which shoe made the print?

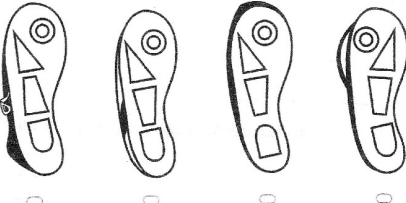

Question 25(S)

Meg folded this piece of paper along the dotted line.



How did the paper look after she folded it?

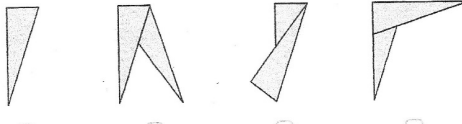

Question 26(C)

Ben folds a piece of paper in half and cuts out an arrow.

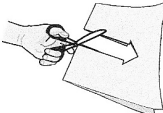

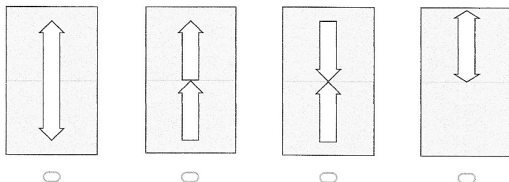

What does the paper look like when he unfolds it?

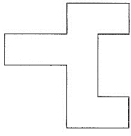

Question  
27(C)

Dan held this shape up to the mirror this way.



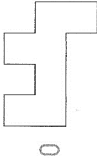
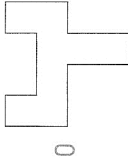
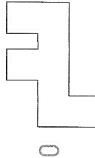
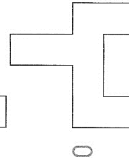

Which reflection would he see in the mirror?

Question  
28(C)

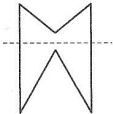
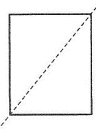
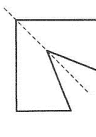
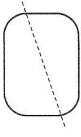

Which of these shapes is symmetrical about the dotted line?





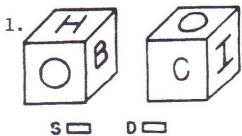
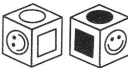

## Appendix E

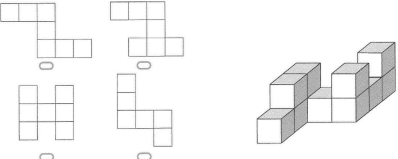
### Overview of Lessons and Testing Materials

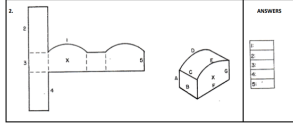
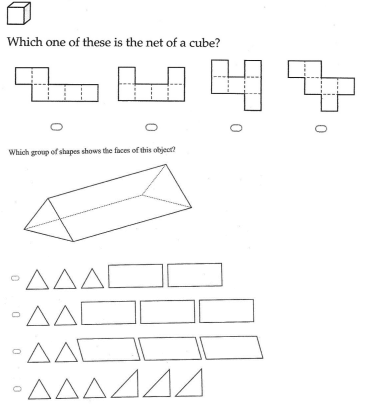
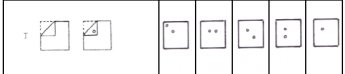
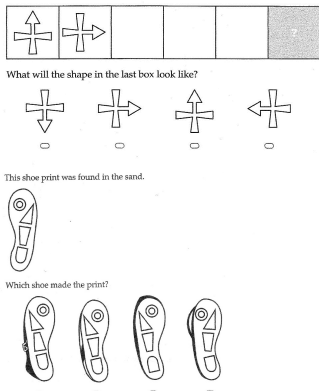
*Overview of the six lessons together with the aspects of the tests that they explored*

Lesson	Spatial Concept	Questions	
		Spatial Ability Test	Naplan Test
<p>1. Point of View – Exploration of 3D shapes from front view and back view orientation.</p>	<p><b>Spatial Orientation</b> - ability to perceive figures as a whole from different orientations - identifying objects when seen from different positions</p>	<p><b>SO (Spatial Orientation)</b> Question example:</p>  <p>1. <input type="checkbox"/> <input type="checkbox"/></p>	<p><b>NO (Spatial Content Knowledge Test)</b> • Questions 1–10 Question examples:</p> <p>Here are two pictures of the same cube. Each face has a different symbol on it.</p>  <p>Which face is opposite to the  face?</p> <p><input type="checkbox"/> <input type="checkbox"/> <input type="checkbox"/> <input type="checkbox"/></p> <p>Which one of these could be a top view of the 3D object shown here?</p> 
<p>2. Point of View – Further exploration of orientation (front, back, side and top view) using Lego brick models.</p>			
<p>3. Point of View – Further exploration of orientation (front, back, side and top view) using Lego brick models.</p>			

Lesson	Spatial Concept	Questions	
		Spatial Ability Test	Naplan Test
4. Exploring Properties of 3D Shapes –	<b>Spatial Visualisation 1</b> - ability to mentally restructure figure components with manipulation	<b>SV1 (Spatial Visualisation Test 1)</b>  Question example: 	<b>NV1 (Spatial Content Knowledge Test)</b> • Questions 11–19 Question examples: 
5. Exploring Properties of 3D Shapes –		<b>SV2 (Spatial Visualisation Test 2)</b>  Question example: 	<b>NV2 (Spatial Content Knowledge Test)</b> • Questions 20–28 Question examples: 
6. Transformation (Reflection Symmetry) –	<b>Spatial Visualisation 2</b> - ability to mentally rotate spatial configurations using short term memory		

## Appendix F

### Comprehensive Overview of Teaching Experiment Lessons

Lesson & Concept	Parts of lesson	Concrete Lesson	Virtual Lesson
<b>L1SO</b>  Spatial Orientation: Point of View	Orientation (Review of Previous lesson)	Whole class, explicit teaching of position language (e.g., in front of, behind, in between, left, right, etc.). Students are asked to move into different positions (e.g., stand behind the chair; put the chair on the left-hand side of the desk)	Whole class, explicit teaching of position language (e.g., in front of, behind, in between, left, right, etc.) Interactive Whiteboard activity of students positioning a virtual object into different positions within a model on screen. <a href="http://www.iboard.co.uk/iwb/Naming-Positions-The-Picnic-677">http://www.iboard.co.uk/iwb/Naming-Positions-The-Picnic-677</a> and <a href="https://www.tes.co.uk/teaching-resource/position-them--the-picnic-6032389">https://www.tes.co.uk/teaching-resource/position-them--the-picnic-6032389</a>
	Enhance: Explicit Modelling	Using similar words and explanations as the App, in pairs students explore how objects look when moved closer or further away from a person looking at the front view of <b>various 3D shapes</b> .  Students explore different views of 3D objects from different viewpoints (Front, Back and Side)	Exploration of the App P.O.V. ( <a href="https://itunes.apple.com/au/app/p.o.v.-spatial-reasoning-game/id532611500?mt=8">https://itunes.apple.com/au/app/p.o.v.-spatial-reasoning-game/id532611500?mt=8</a> )  In pairs complete the “Intro & Explore” section of the App.  Discuss: What happens when move objects closer to camera? etc
	Enhance: Guided Application	Rearrange the 3D shapes on a table. Working in pairs, ask children to describe/draw from different viewpoints. Ask them to move one object and talk about the difference in the picture. While looking at objects from the front. Draw what you think they will look like from the back. In pairs, check your answers. While looking at objects from the front. Draw what you think they will look like from the side. In pairs, check your answers.  (Discuss: What was difficult/easy? What things helped you?)	Students, in pairs, complete the Activity in the app:  1. “Vantage Point” (Discuss: What was difficult/easy? What things helped you?) Which camera angle is the top picture from?  2. “Make a Scene” (Discuss: What was difficult/easy? What things helped you?) From the highlighted camera angle, make the camera view picture by moving the shapes into the correct position. The sneak view shows you what it looks like at the moment.  <i><u>Vantage Point</u></i> <i><u>Make a Scene</u></i>

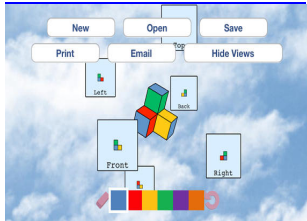

Lesson & Concept	Parts of lesson	Concrete Lesson	Virtual Lesson
	Synthesise	<p>What did you learn? Do objects look the same from different positions? Why? What skills are we using to do this? Can you imagine objects in your head from different points of view?</p>	 <p>What did you learn? Do objects look the same from different positions? Why? What skills are we using to do this? Can you imagine objects in your head from different points of view?</p>

Lesson & Concept	Parts of lesson	Concrete Lesson	Virtual Lesson
<b>L2SO</b>  Spatial Orientation: Point of View	Orientation (Review of Previous lesson)	Revise previous lesson. What did we do? What did you learn? Introduce the directional language to be used in the lesson (front/back/left/right/top/bottom).	Revise previous lesson. What did we do? What did you learn? Introduce the directional language to be used in the lesson (front/back/left/right/top/bottom).
	Enhance: Explicit Modelling	Using similar words as found in the app: 1. In pairs, students discuss what a <b>cube with different-coloured sides</b> looks like from the front, back, top and bottom views. 2. Explicitly model for students how to create a block formation using <b>different-coloured Lego blocks</b> . Describe what the blocks look like from different views. Get students to walk around the block formation to describe what it looks like from different views.	Using the app, <a href="https://itunes.apple.com/au/app/3d-views/id524997945?mt=8">https://itunes.apple.com/au/app/3d-views/id524997945?mt=8</a> 
	Enhance: Guided Application	In pairs students explore making their own formations. The 1 <sup>st</sup> student builds a block formation of 5 blocks. The 2 <sup>nd</sup> student has to describe and draw what the formation looks like from the front/back/left/right/ top and bottom. The 1 <sup>st</sup> student then looks at the 2 <sup>nd</sup> student's work and tells them if they think they are right. When they think they have it right they ask the teacher if they are correct.	1. Teacher models how to create a single cube and colour each side in a different colour. In pairs, students discuss what a cube with different-coloured sides looks like from the front, back, top and bottom views. 2. Explicitly model how to create a block formation (and change colours) and use the "show views/hide views" function. Use descriptive language to describe what the shape looks like from different points of view.
Synthesise	Discuss the skills that students had to use to know what it will look like from different points of views. Was it simple or hard? What did they do to help them figure out the answer? Did you have to picture in your mind what the blocks looked like?	In pairs students explore the app. The 1 <sup>st</sup> student builds a block formation of 5 blocks. (and makes sure the hide views functions is on) The 2 <sup>nd</sup> student has to describe and draw what the formation looks like from the front/back/left/right/top and bottom. The 1 <sup>st</sup> student then looks at the 2 <sup>nd</sup> student's work and tells them if they think they are right. They both use the "show views" function to check their work. They swap and repeat Discuss the skills that students had to use to know what it will look like from different points of views. Was it simple or hard? What did they do to help them figure out the answer? Did you have to picture in your mind what the blocks looked like?	

Lesson & Concept	Parts of lesson	Concrete Lesson	Virtual Lesson
<b>L3SO</b> Spatial Orientation: Point of View	Orientation (Review of Previous lesson)	Revise previous lesson. Can you remember what you were thinking when view the Lego bricks from different positions?	Revise previous lesson. Can you remember what you were thinking when using the iPad to view the coloured block from different positions?
	Enhance: Explicit Modelling	Model for students how to create a model using the <b>Lego bricks</b> (just like in previous lesson). Using the <b>stuffed animals</b> model where you would stand for a Bird's eye view (top view), Kangaroo's View (Front view), Dog's view (side view). Share an example of how to complete the activity by describing the position of different coloured bricks from the 3 different positions.	Explain how the app works, do a walk through of app. <a href="https://itunes.apple.com/au/app/p-rance-a-lot/id716442439?mt=8">https://itunes.apple.com/au/app/p-rance-a-lot/id716442439?mt=8</a>
	Enhance: Guided Application	In pairs, students create a model using the Lego bricks and the grid on the paper. Students are to draw the front, side and top view. Students share their drawing with each other explaining why they drew what they drew.	Explain the help function. In pairs, students play with the app, constructing the model from different viewpoints. Talk with your partner, explaining how you know where to put the haystacks.
	Synthesise	How did the Lego Bricks help you with your thinking? When you were trying to do the top/side view, what were you thinking? Which animal's viewpoint was the easiest & why? What made it easy/hard for you? How did you know where to put the Lego bricks?	How did the iPad help you with your thinking? When you were trying to do the top/side view, what were you thinking? Which animal's viewpoint was the easiest & why? What made it easy/hard for you? How did you know where to put haystacks?



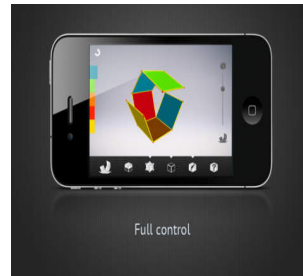

Lesson & Concept	Parts of lesson	Concrete Lesson	Virtual Lesson
L1SV  Spatial Visualisation: 3D objects & Nets	Orientation (Review of Previous lesson)	Teacher led Introductory activity using a <b>Cube</b> to revise features of 3D objects (e.g., Face, Vertices, Edges)	Teacher led Introductory virtual activity to revise features of 3D objects (e.g., Face, Vertices, Edges) <a href="http://illuminations.nctm.org/Activity.aspx?id=3521">http://illuminations.nctm.org/Activity.aspx?id=3521</a>
	Enhance: Explicit Modelling	Teacher models <b>various 3D objects</b> that unfold to reveal their nets. The teacher models how to identify and count the number of faces, edges and vertices on each of the 3D objects.	Model how to use the app. <a href="https://itunes.apple.com/au/app/solids-elementary-hd/id501650786?mt=8">https://itunes.apple.com/au/app/solids-elementary-hd/id501650786?mt=8</a>
	Enhance: Guided Application	Students physically explore 3D objects in pairs, using language like faces, edges, vertices and 2D shape names. Students are to record the number of faces, edges and vertices of each 3D shape.	Students explore 3D shapes from the app in pairs, using language like faces, edges, vertices and 2D shape names. Students are to record the number of faces, edges and vertices of each 3D shape.
Synthesise	How did the 3D objects that unfold help your thinking? What did you like the best/worst about the 3D objects? What did you find easy/ hard with using the 3D objects?	How did this app help your thinking? What did you like the best/worst about this app? What did you find easy/ hard with this app?	



Show/model functions (picking a shape/ unfolding it to its net/ highlighting edges & vertices/ rotation of shape to look at faces)

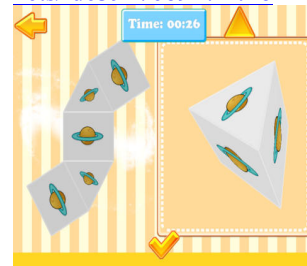
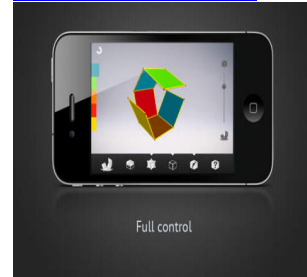

Lesson & Concept	Parts of lesson	Concrete Lesson	Virtual Lesson
<b>L2SV</b>  Spatial Visualisation: 3D objects and Nets	Orientation (Review of Previous lesson)	Review previous lesson, revising terms Faces, edges, vertices and shape names.	Review previous lesson, revising terms Faces, edges, vertices and shape names. <a href="https://itunes.apple.com/au/app/solids-elementary-hd/id501650786?mt=8">https://itunes.apple.com/au/app/solids-elementary-hd/id501650786?mt=8</a>
	Enhance: Explicit Modelling		Teacher models the four activities found in the app <a href="https://itunes.apple.com/au/app/3d-shapes-and-nets/id639476891?mt=8">https://itunes.apple.com/au/app/3d-shapes-and-nets/id639476891?mt=8</a>
	Enhance: Guided Application	In pairs, students play games of finding 1. the correct net for a given 3D object; 2. the correct 3D object for a given 2D net. Students are also given time to explore the 3D objects and unfold them into their nets; and 3. Students record what 2D shapes are needed to create the nets of 3D objects.	In pairs, students explore 1. rotating 2D shapes to form the 3D object; 2. selecting the correct net that could be folded into the given 3D object; 3. selecting the 3D shape that could be made from the given net; and 4. the “explore” function which allows selection of a 3D object to unfold into its net.
Synthesise	What skills assisted you in trying to visual the 3D objects and nets? How did the 3D objects that unfold help your thinking? What did you like the best/worst about the 3D objects? What did you find easy/ hard with using the 3D objects?	What skills assisted you in trying to visual the 3D objects and nets? How did this app help your thinking? What did you like the best/worst about this app? What did you find easy/ hard with this app?	



Lesson & Concept	Parts of lesson	Concrete Lesson	Virtual Lesson
L3SV Spatial Visualisation: Symmetry	Orientation (Review of Previous lesson)	Introductory activity of folding a piece of paper in half, quarters and eighths. Students then cut out different shapes from the paper. Students unfold paper and observe/discuss what has happened. Teacher led discussion on what “symmetry” is.	Students create a symmetrical pattern on the app <a href="https://itunes.apple.com/US/app/id327084738">https://itunes.apple.com/US/app/id327084738</a> 
	Enhance: Explicit Modelling	Using <b>geo-mirrors</b> and <b>various coloured shapes</b> , the teacher models how to create a symmetrical pattern.	Teacher led discussion on what “symmetry” is. Teacher models how to complete the task in the app <a href="https://itunes.apple.com/au/app/symmetry-school-learning-geometry/id648579648?mt=8">https://itunes.apple.com/au/app/symmetry-school-learning-geometry/id648579648?mt=8</a> 
	Enhance: Guided Application	In pairs, students create symmetrical patterns. The 1 <sup>st</sup> student places coloured shapes in a pattern on the left side of the paper. The 2 <sup>nd</sup> student used the geo-mirror to create the symmetrical pattern on the right side. The students swap over.	In pairs, one student completes the task and explains their thinking to their partner. The students swap over.
	Synthesise	What things did you use to help your thinking? What parts did you find hard/easy? Did you need to use the geo-mirror to figure out the symmetrical pattern? Explain why/why not?	What things did you use to help your thinking? What parts did you find hard/easy? Did you need to use the help function to figure out the symmetrical pattern? Explain why/why not?

## Appendix G

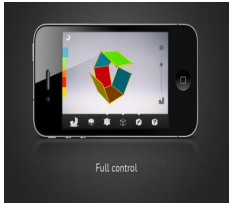
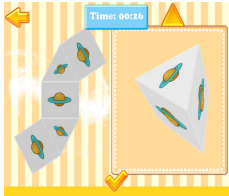
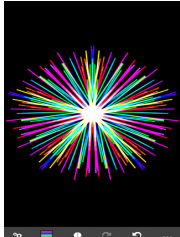
### Brief Overview of Matched Lessons

Lesson	Spatial skill	Tasks	Concrete	Virtual App
1 L1SO	Orientation	Use positional language to describe the position of 3D shapes	3D Shapes (Prisms and Pyramids)	P.O.V. - Spatial Reasoning Game and Left Right Discrimination By BinaryLabs, Inc. 
2 L2SO	Orientation	Use positional language to describe the position of coloured faces of cube/multiple coloured bricks	3D Cubes Lego Bricks	3D Views By MATHapps LLC 
3 L3SO	Orientation	Use positional language to describe the position of multiple coloured blocks (front, back and side view)	Lego Bricks	Prance-A-Lot By Fun Digital 
4 L1SV	Visualisation	Match 3D objects to nets	3D Shapes Nets	Solids Elementary HD By Setapp Sp. z o. o. 
5 L2SV	Visualisation	Match Nets to 3D objects	3D Shapes Nets	3D Shapes and Nets By Hon Fai Dennis Yu 
6 L3SV	Visualisation	Symmetry (Fold transformations)	GeoMirror Counters Grid Paper	Symmetry Lab By Luke Bradford  Symmetry School: Learning Geometry By PixelSoup Ltd  

## Appendix H

### Researcher's Field Notes from the Teaching Experiment

PM CLASS	VM CLASS
<u>Lesson 1 – Spatial Orientation</u>	
<ul style="list-style-type: none"> <li>Most students understood depth perception as showed 3D shapes in their drawings via lines and shading</li> <li>Quicker delivery</li> <li>Children didn't receive feedback if incorrect unless the teacher was there</li> </ul>	<ul style="list-style-type: none"> <li>More 'on task' talk from students</li> <li>Allows multiple examples of same idea</li> <li>Fostered more talk especially with teacher</li> </ul>
<p>Conjectures:</p> <ol style="list-style-type: none"> <li>physically moving the iPad for the camera angle (so that camera is in front of student) assisted some students in making links to learning orientation skills (even though they could click on a camera to show the side view, some student still had to physically move the iPad onto the side)</li> </ol>	
<u>Lesson 2 – Spatial Orientation</u>	
<ul style="list-style-type: none"> <li>Made the connection of physical movement to imagining/visualising (more likely to express ideas, thoughts, learning)</li> </ul>	<ul style="list-style-type: none"> <li>Lost 'front' position</li> <li>Easier as provided instant feedback through the 'show view' function</li> <li>'show view' function seemed to limit their connection to physical world??</li> </ul>
<p>Conjectures:</p> <ul style="list-style-type: none"> <li>students need physical trigger at start of lesson to recall previous lesson (showed app but needed to physically see what meant – square and ball)</li> <li>the physical movement is what linked students' ideas for POV. Kinaesthetic of actually moving assisted learning (virtual group struggled as they didn't understand the movement or have the kinaesthetic stimulation of themselves as part of the perception/positioning. Therefore, next lesson initiate with kinaesthetic point of reference.</li> <li>Need a point of reference to allow abstract thought in position. Students need intermittent steps to bridge through (too abstract). Therefore, next lesson needs to provide these steps to assist learning</li> <li>As the students using virtual didn't physically move to see a different perspective not able to fully grasp the concept.</li> </ul>	
<u>Lesson 3 – Spatial Orientation</u>	
<ul style="list-style-type: none"> <li>children described Lego helping them because of colour and position</li> <li>animals helped them by giving them a point of reference (where to see/view from)</li> <li>students could move to the animal's position to see their viewpoint</li> <li>didn't make connection between speaking positional language helped them think where the position in paper would be</li> </ul>	<ul style="list-style-type: none"> <li>app fostered (through multiple examples) a lot of positional language talk amongst students</li> <li>the use of an app with static positions seemed to help them when they went back to the rotational app either that or the language use helps connect their thinking. By using language out loud helped bridge the gap from concrete to abstract</li> <li>children commented on physical movement helping their thinking about position/orientation</li> </ul> <p>children commented on using blocks would help them more because they could physically walk around them to see different positions.</p>
<p>Conjecture:</p> <p>as the teacher, I found it easier to discuss students' thinking with the concrete material as it would help initiate discussion if they could see me moving the materials like they did. Using the app in the same way didn't have the same effect</p>	



<u>Lesson 4 – Spatial Visualisation</u>	
<ul style="list-style-type: none"> <li>children talked more about their sense of seeing the object as being helpful rather than touch. Many students would touch the object to explain their thinking but talk about how seeing it helped them.</li> </ul>	<p>children were able to talk about their thinking and how iPad helped their thinking a lot more</p>
<p>Conjectures:</p> <ul style="list-style-type: none"> <li>as the VM are more abstract and have to be discussed with a partner in abstract/very language based terms; this helps bridge the transfer from the concrete to the abstract</li> </ul>	
<u>Lesson 5 – Spatial Visualisation</u>	
<ul style="list-style-type: none"> <li>some students would move around the 3D object and change their position rather than rotating the 3D shape (PM)</li> <li>students were very engaged in small groups, made connection to their thinking – more enthusiastic, therefore, more sharing of how they think</li> <li>more likely to touch the material this kinaesthetic maybe made it easier for them to discuss their thinking.</li> </ul>	<ul style="list-style-type: none"> <li>students acted as a stationary point of view/reference and moved the object around in the app</li> <li>students enjoyed the game feature of the app</li> </ul>
<p>Conjectures:</p> <ul style="list-style-type: none"> <li>the point of view/reference point may play a role in students’ thinking (i.e., moving self ‘vs’ moving object)</li> <li>the iPad fosters talk/help between partners. The instant feedback allowed them to check their work, which makes them more likely to talk about why they were right or wrong with that partner (and what they could do to fix their mistakes). While with PM the students were more likely to just tell the answer and show with the materials but not use their words to explain</li> </ul>	
<u>Lesson 6 – Spatial Visualisation</u>	
<ul style="list-style-type: none"> <li>Students’ communicated that peers help because they provided feedback and checked the work was right. They said that their friend would move things (not explain it with words but just do it)</li> <li>Students relied on the PM even if they could do the activity without it</li> </ul>	<p>Some students still rely on physically moving the iPad to a different points of view or moving their hands to help them visualise.</p>
<p>Conjectures:</p> <p>With PM students tended to help each other by moving/doing the work for peers rather than using words (maybe effect of learning)</p>	

OVERALL CONCEPTS/THEMES to explore

1. Language
2. Interaction with manipulatives/representations
3. Transferability of learning (manipulatives to 2D representations)
4. The role of peers
5. App functions (e.g., feedback, show functions, multiple examples)
6. Teaching (what the teacher does)

Physical Manipulatives		Virtual Manipulatives	
Positives	Issues	Positives	Issues
When explaining students having difficulties talking about their thinking could point and act out what they meant	Time to organise/handout materials (including clean up)	Short time to set up and change between resources (apps)	Technical issues – app not working/sound not working/etc.
Students see them as ‘real’, therefore, could touch and move as needed to help thinking	Students fiddle/play with during instructions	Fosters talking about thinking. Children couldn’t easily show what they were thinking so they had to use language/words to describe to others	Instant feedback (show views) provides an easy out for students. Come students wouldn’t think for themselves or have a go – but just cheat, therefore, limited thinking on students’ behalf.
Students could talk and show what doing/thinking	Students who are struggling with concepts could feel/touch/point rather than use words	Apps allowed for multiple examples to be shown/completed/ Children experienced/explored multiple representations of concepts	
When student see/touches a PM it triggers thought/thinking which they can talk about		Provides instant feedback – students can check as they go (assists in formulating/consolidating concepts)	
		Quicker to use, therefore, associated with being easier	

## Appendix I

### Comparison of Scaffolding Practices for Lesson 3 in PM and VM Classes

PM CLASS – Orientate Phase (levels of scaffolding)

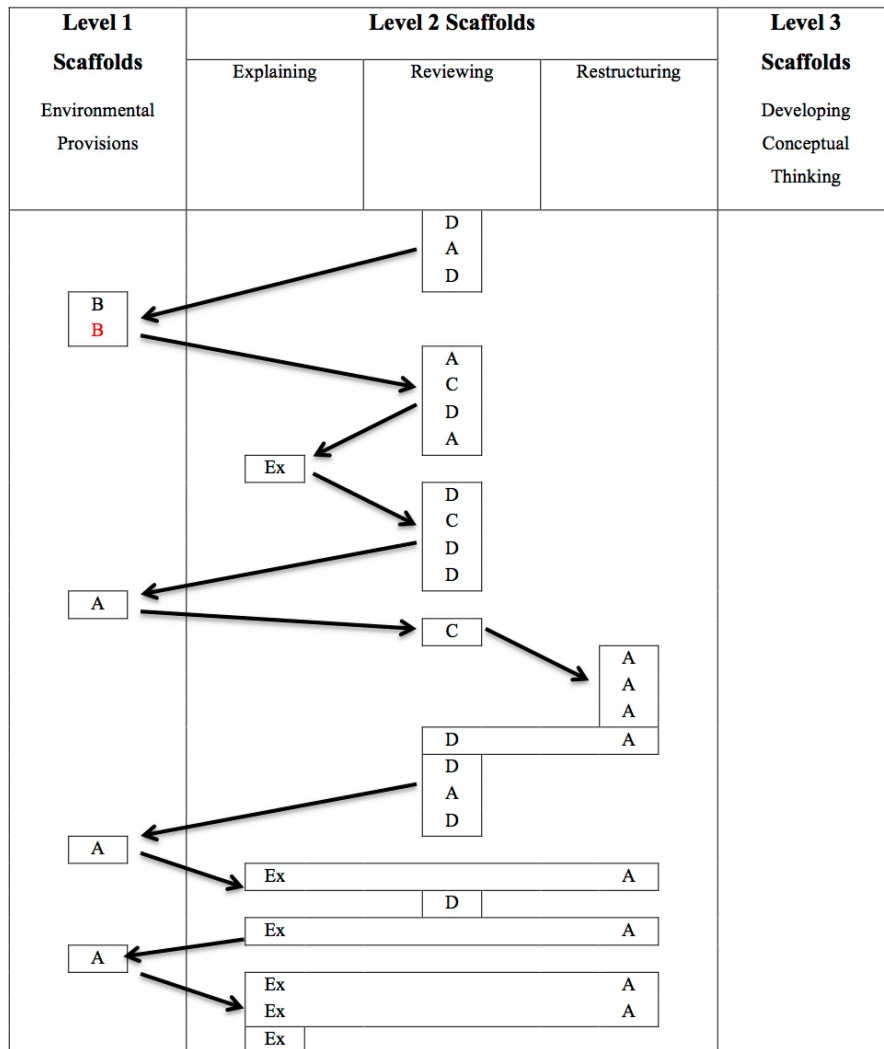

Concrete – Enhance Phase (levels of scaffolding)

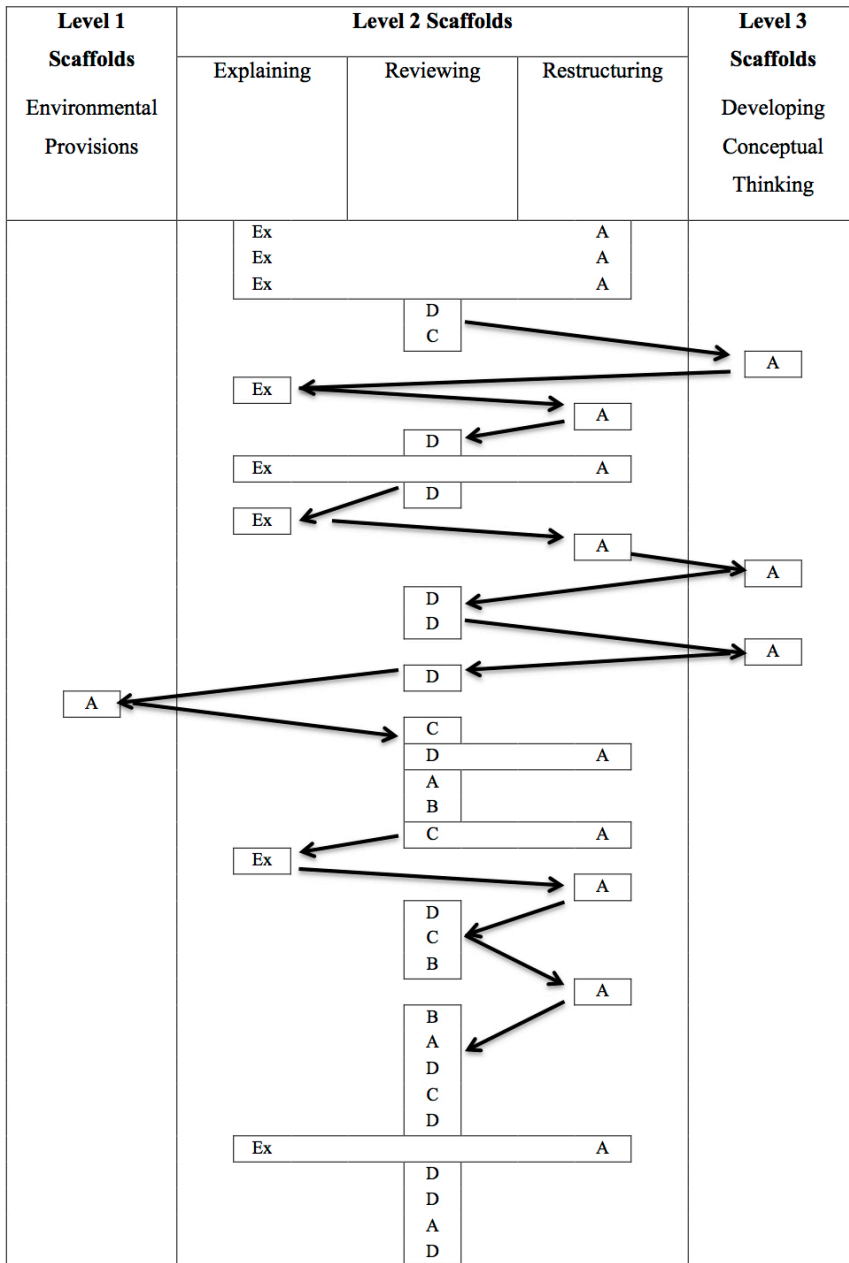

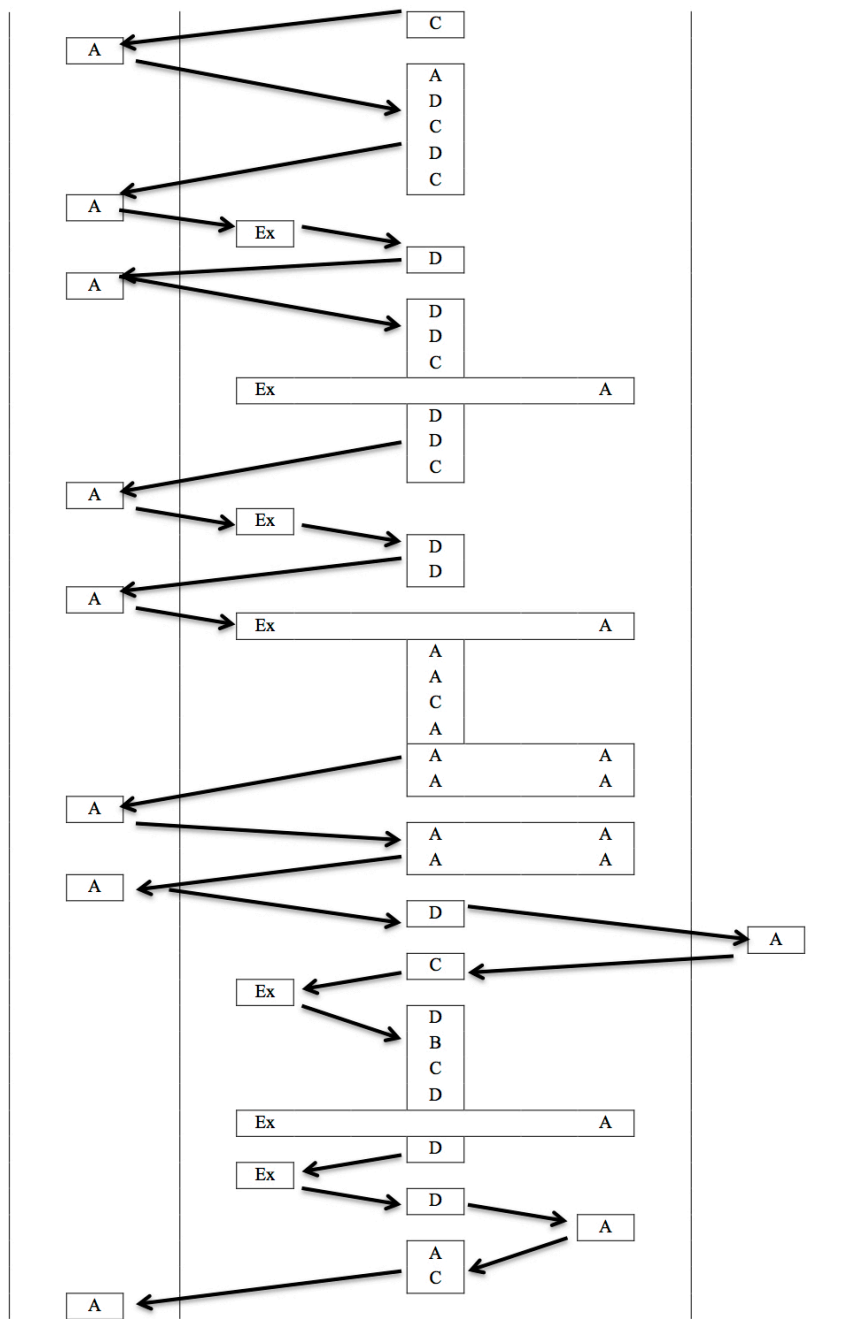

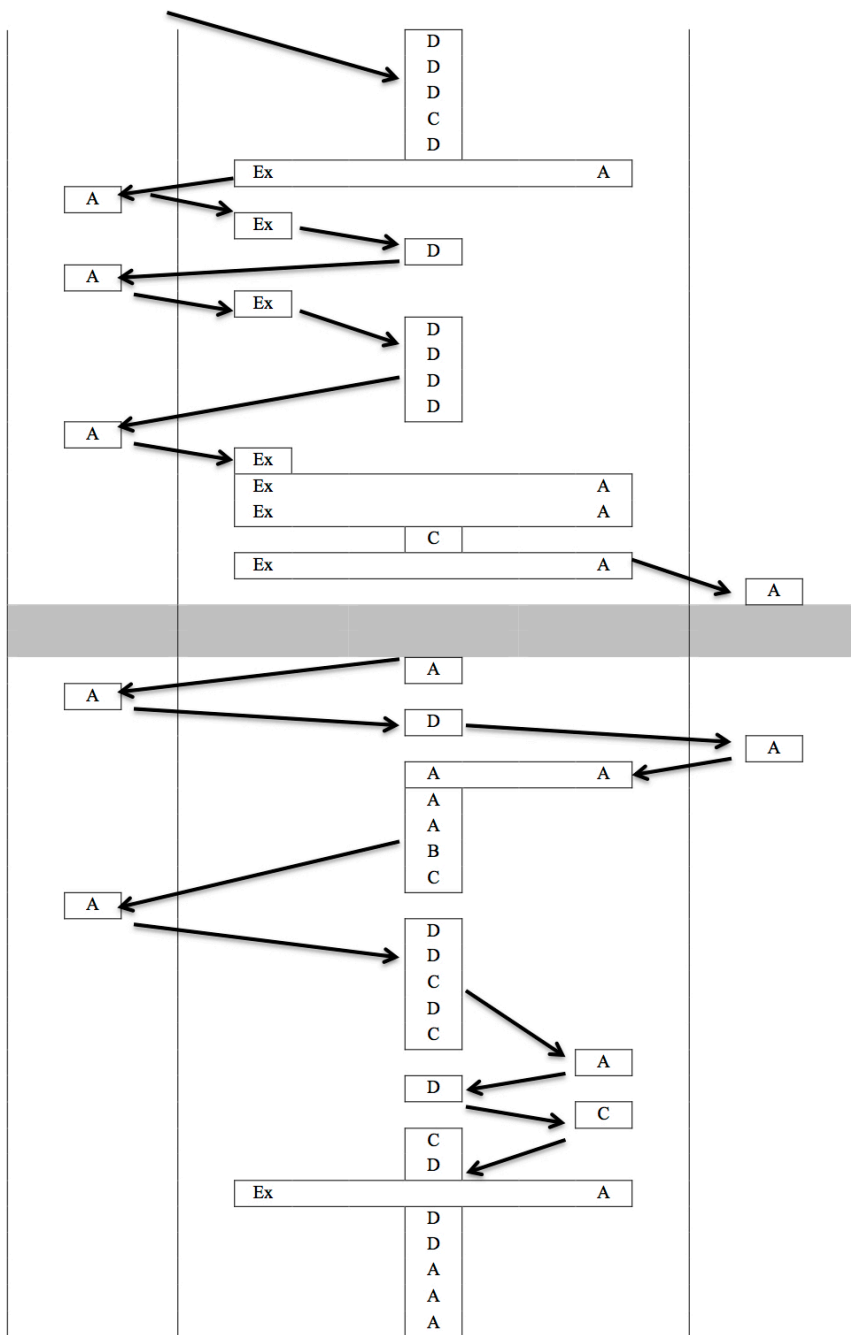

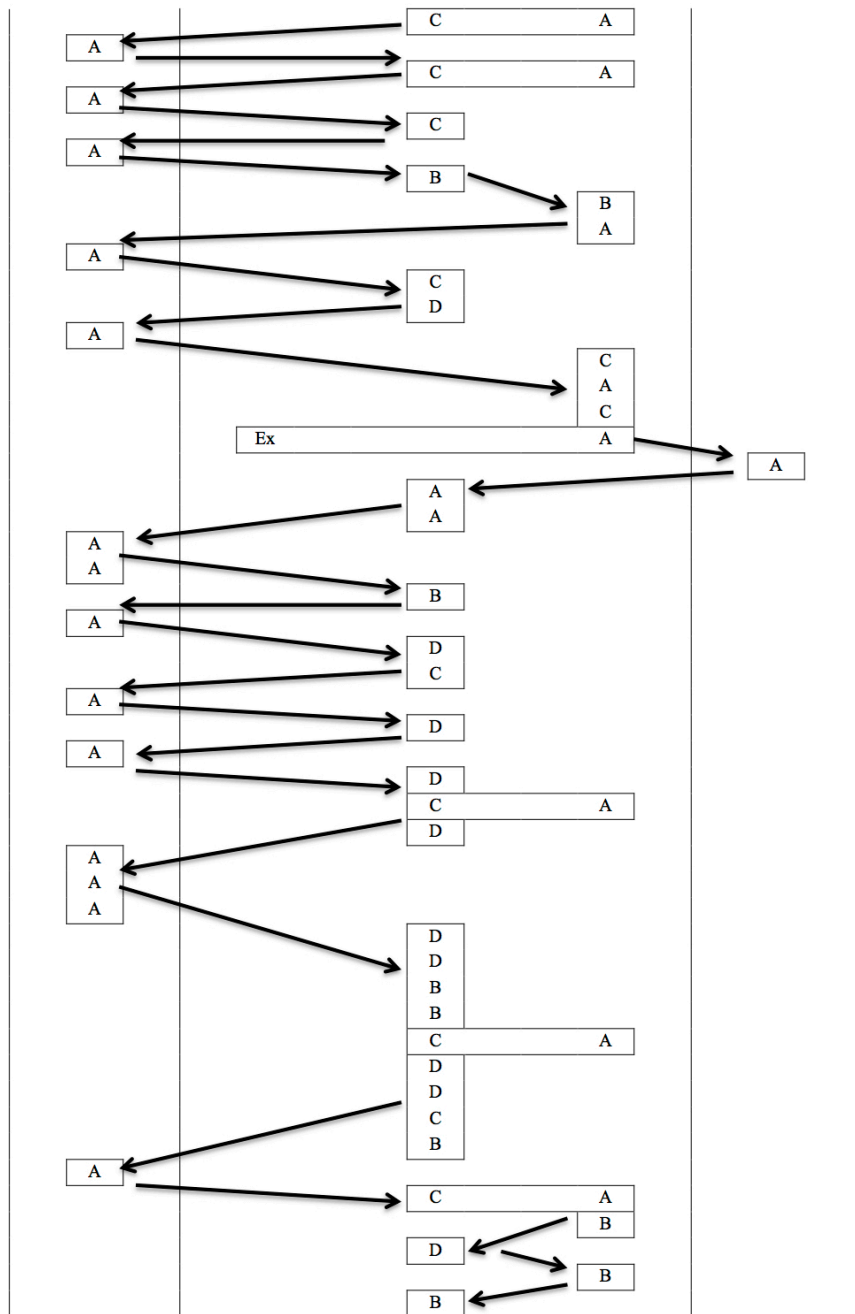

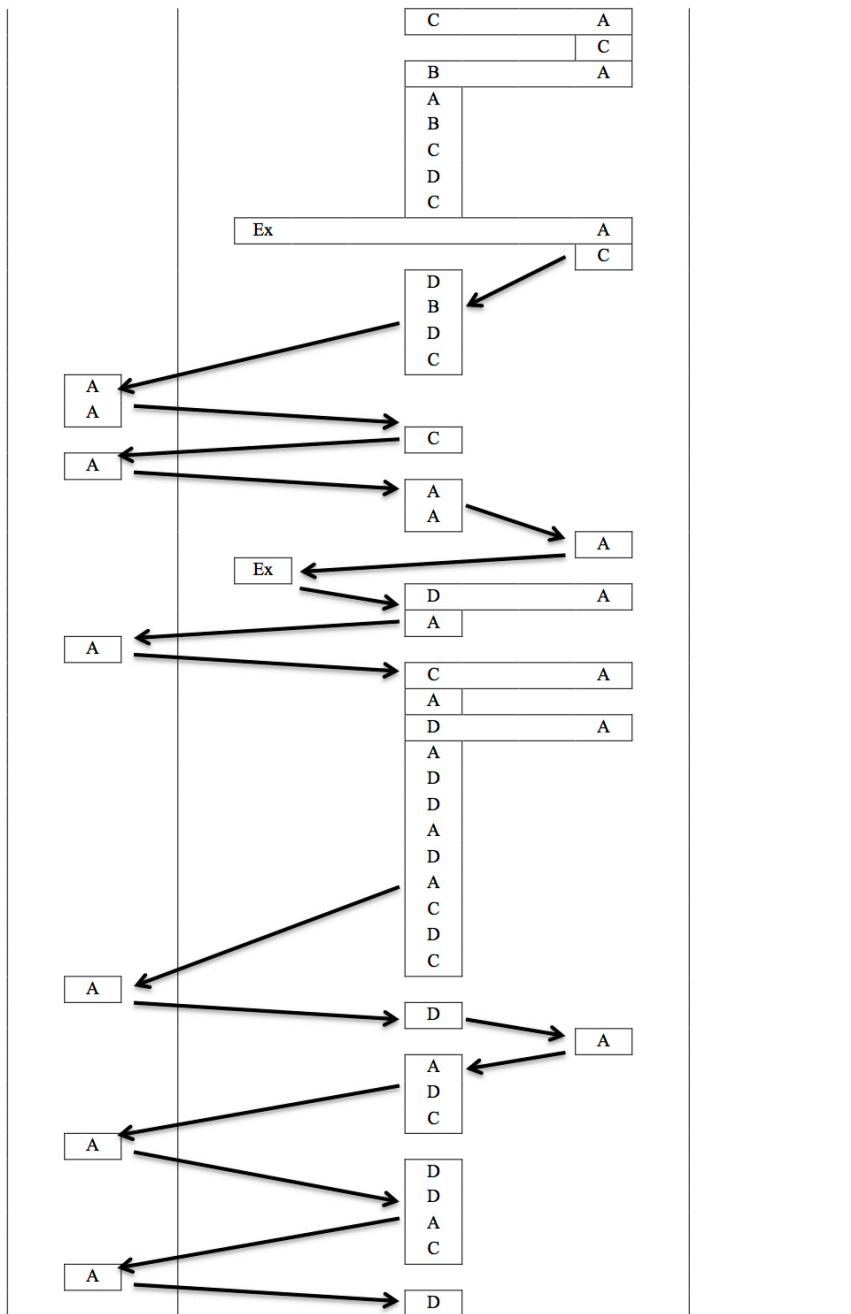



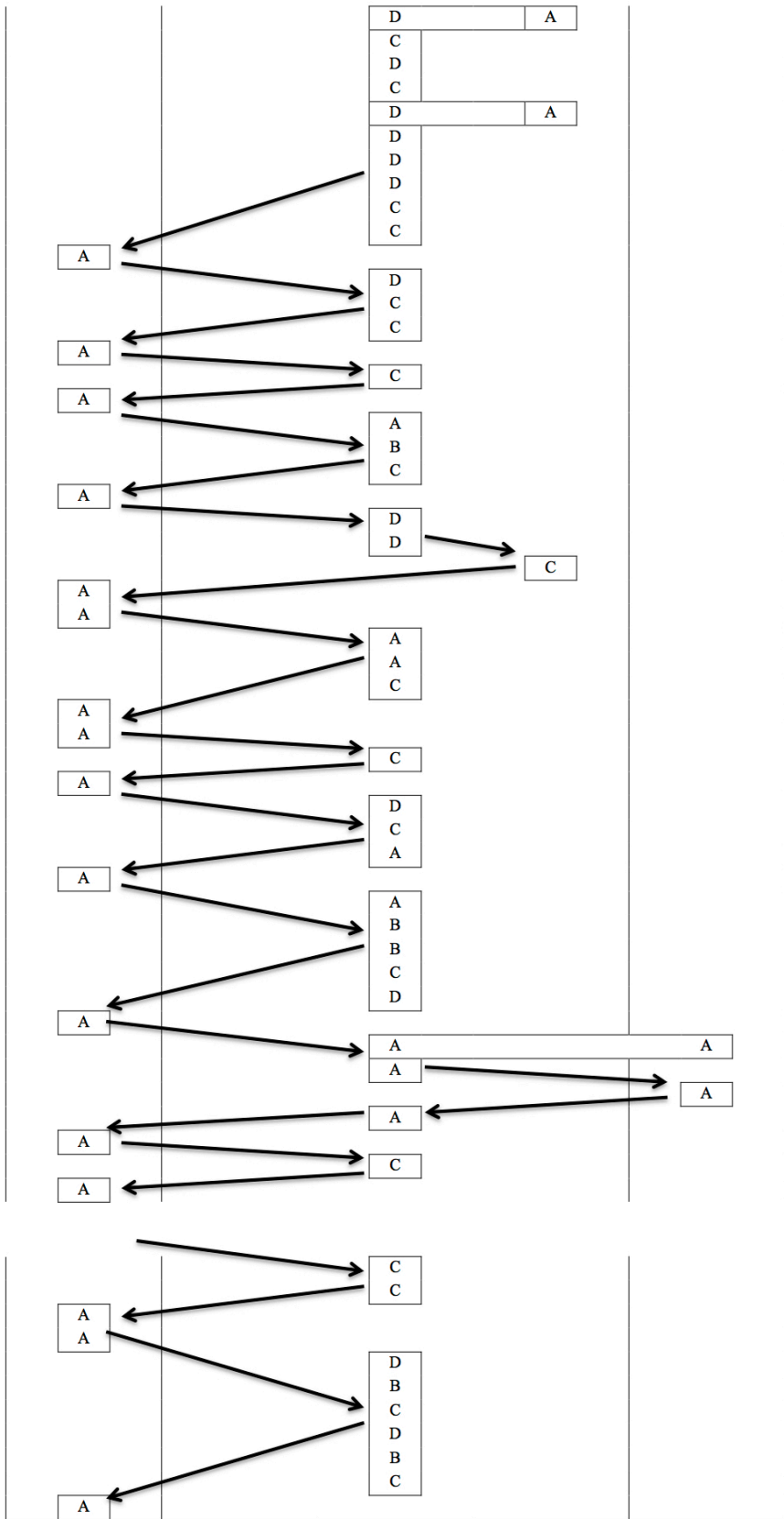

Concrete – Synthesis Phase (levels of scaffolding)

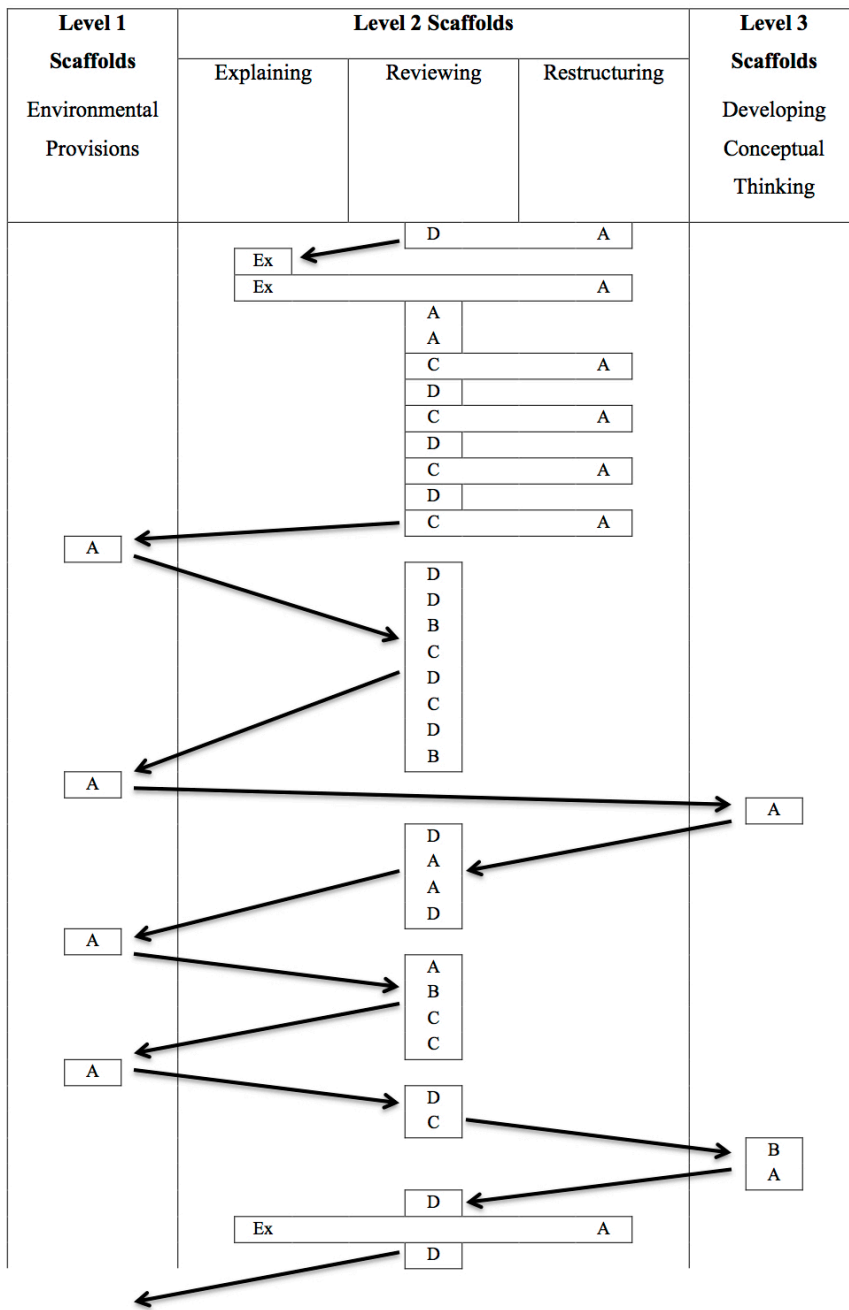

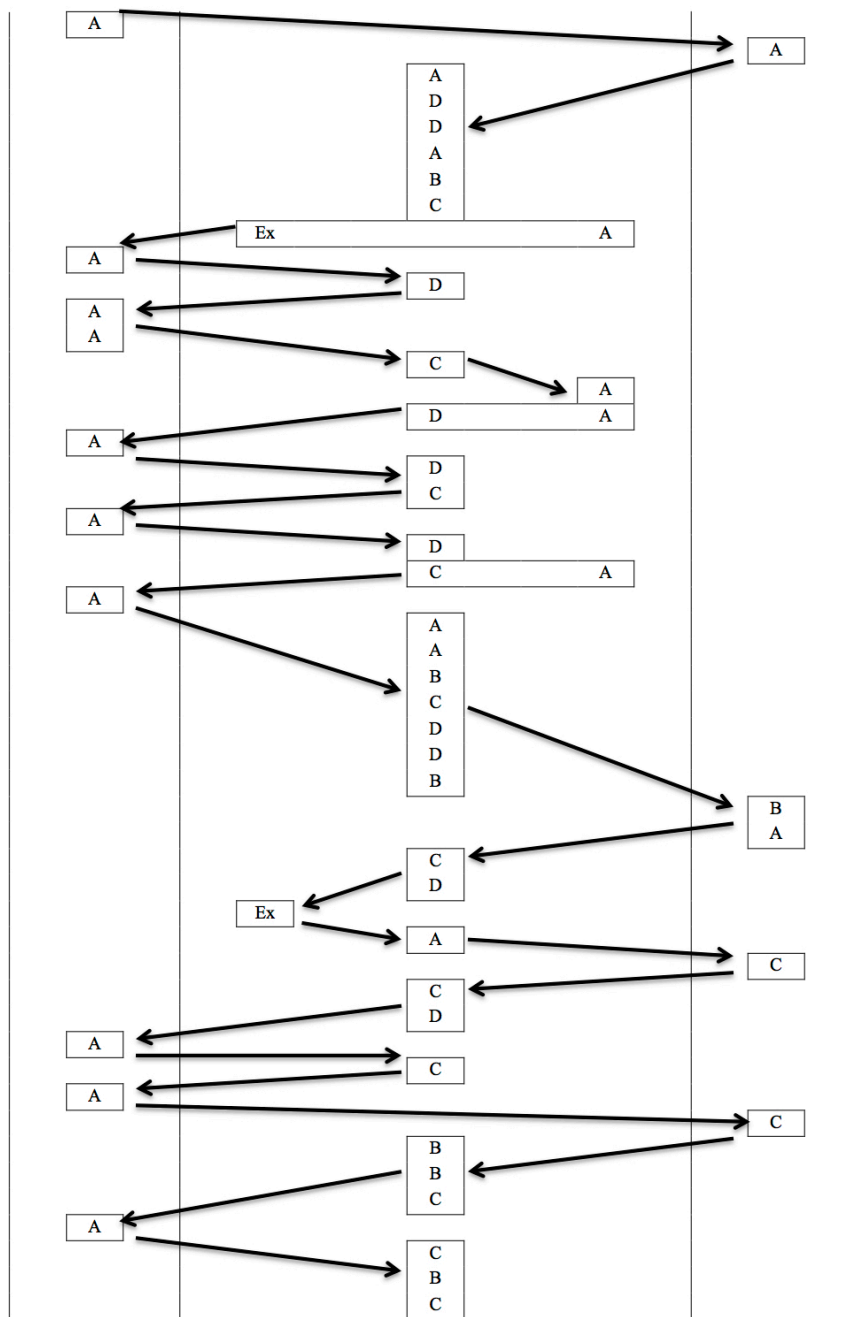

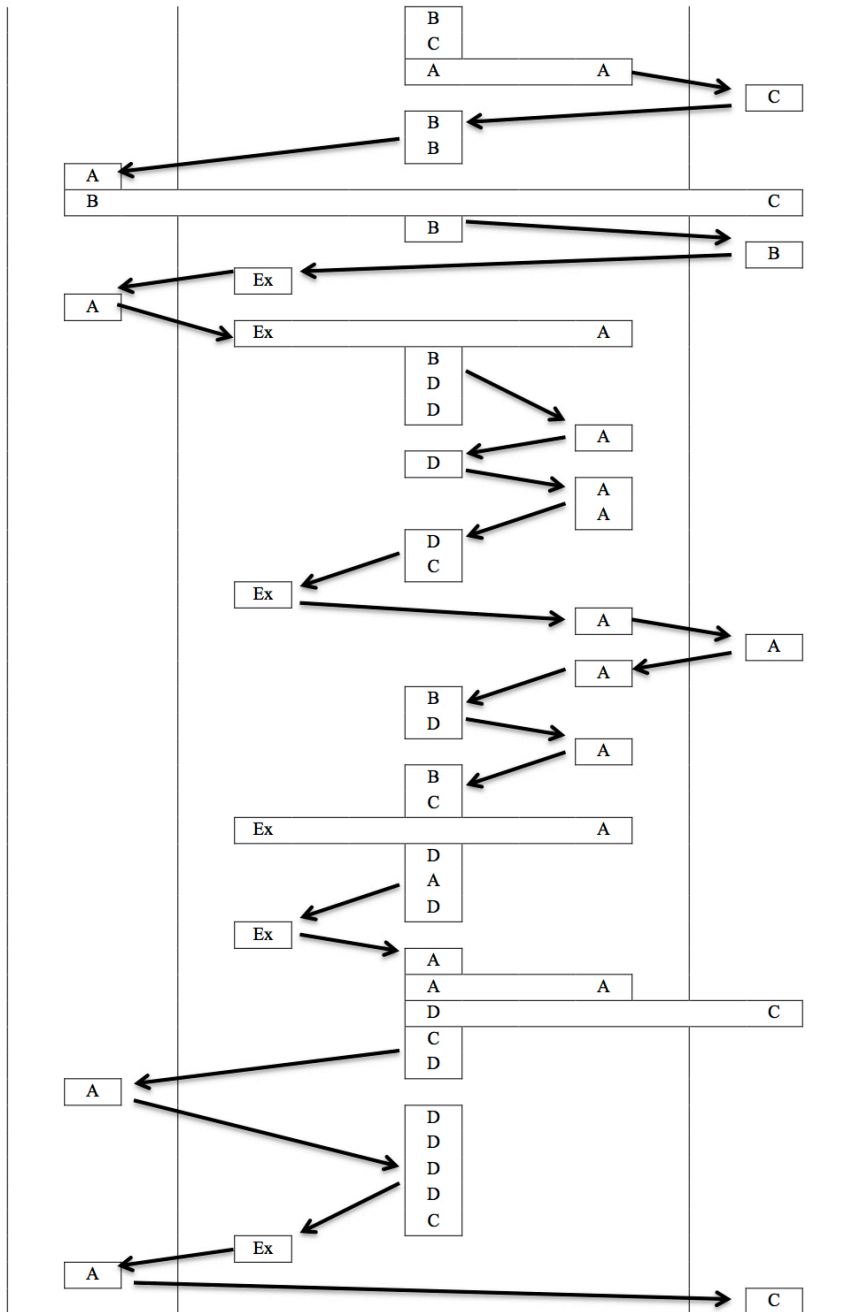

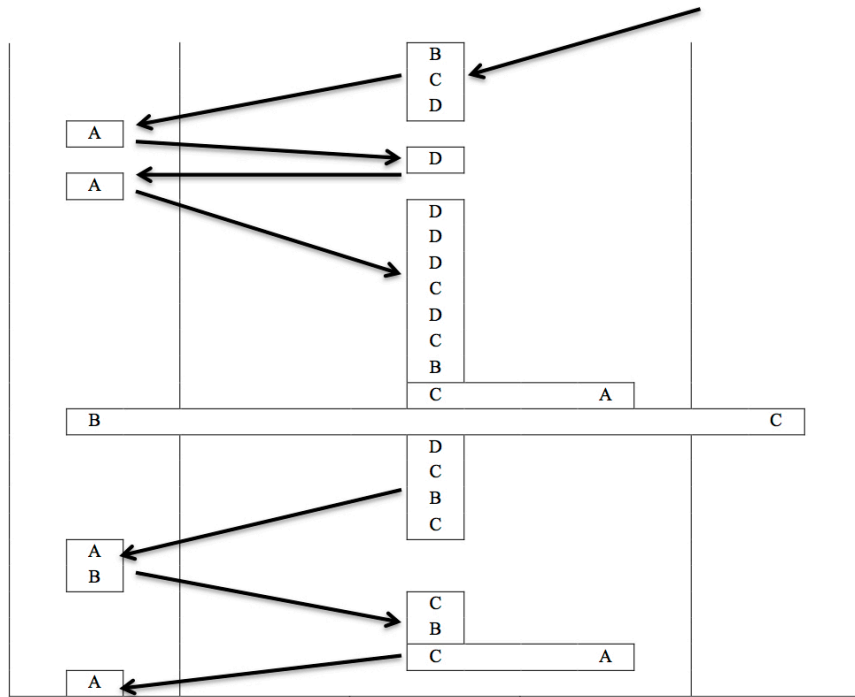

VM CLASS – Orientate Phase (levels of scaffolding)

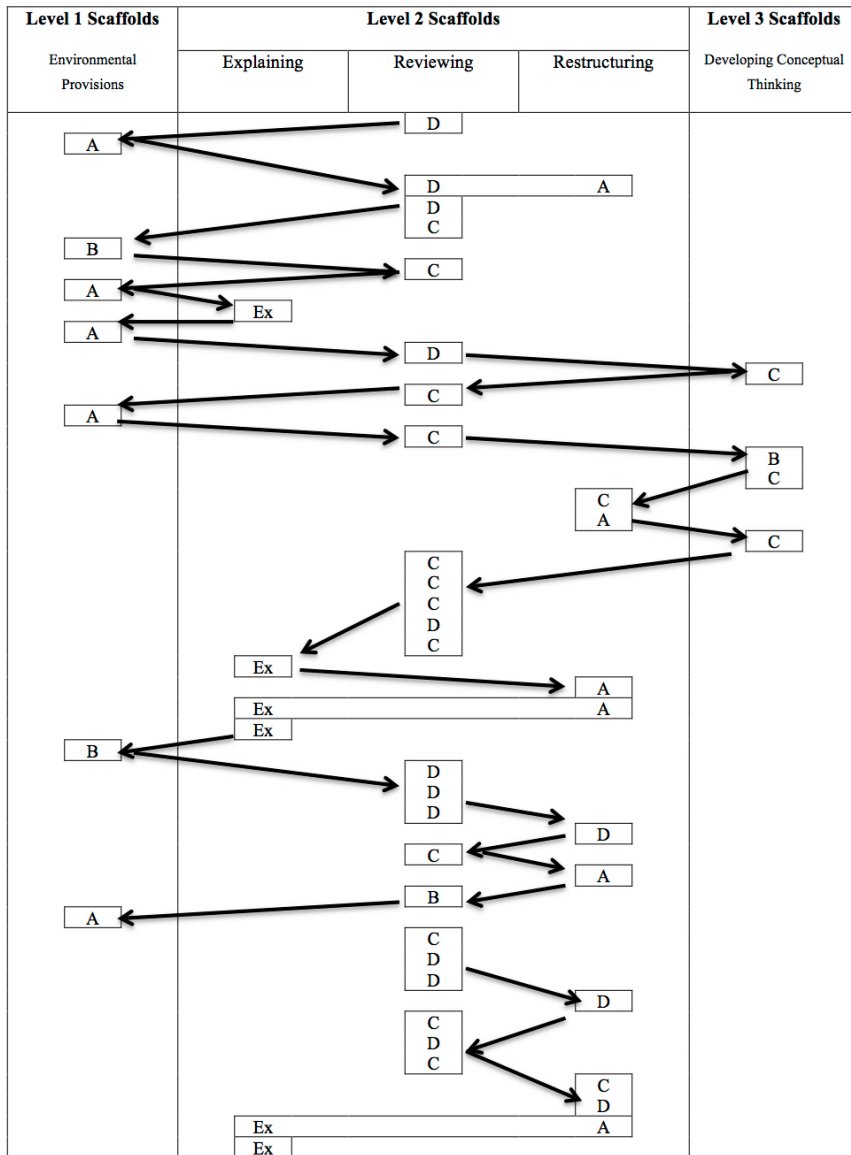

Virtual – Enhance Phase (levels of scaffolding)

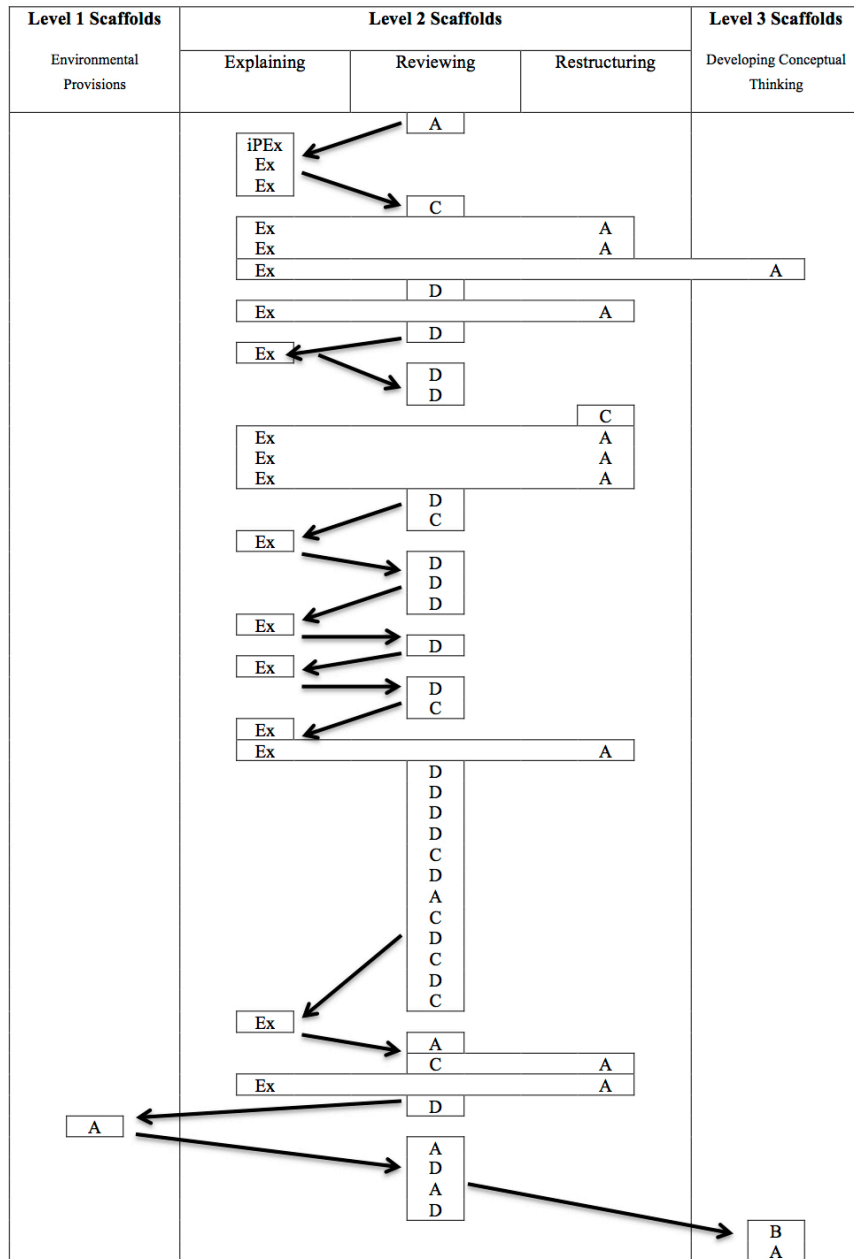

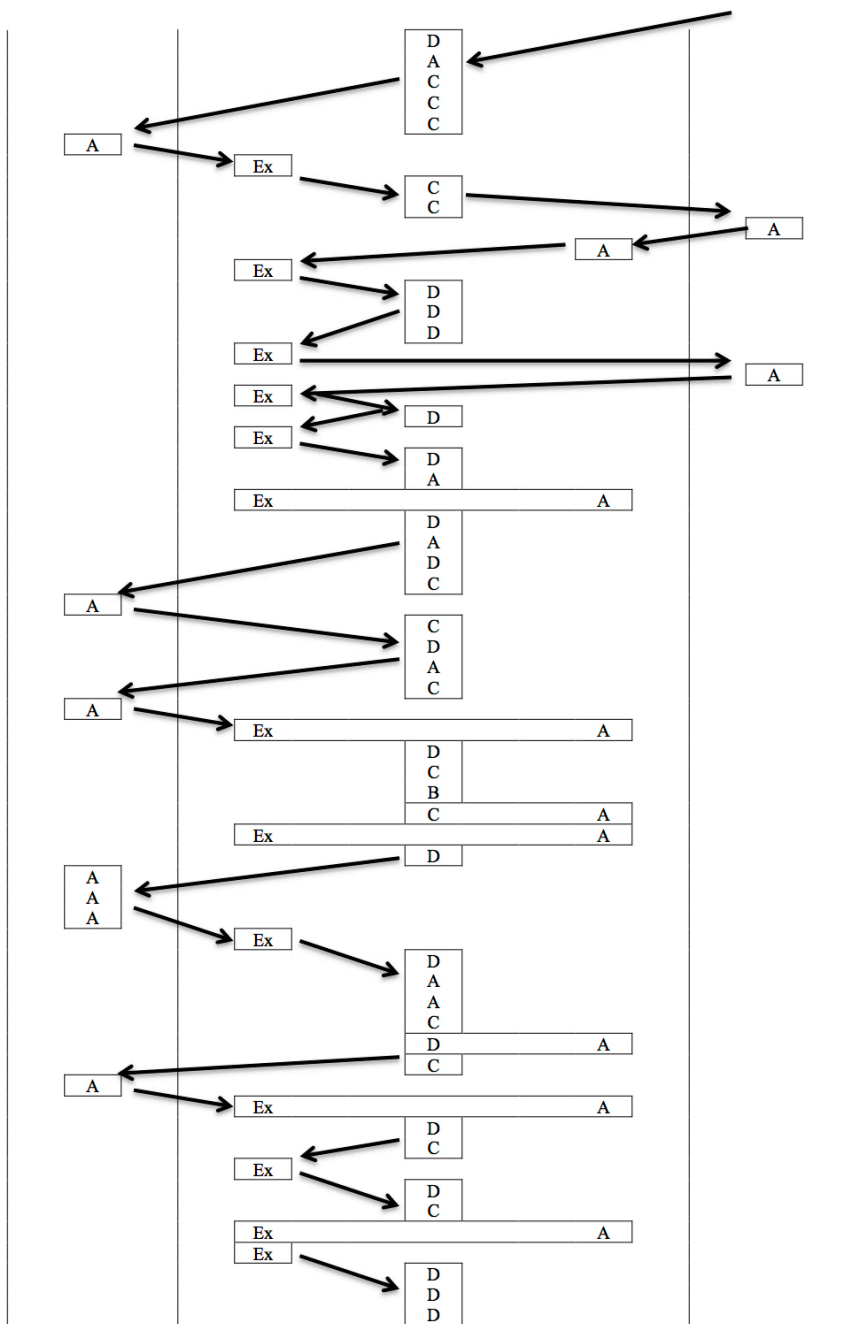



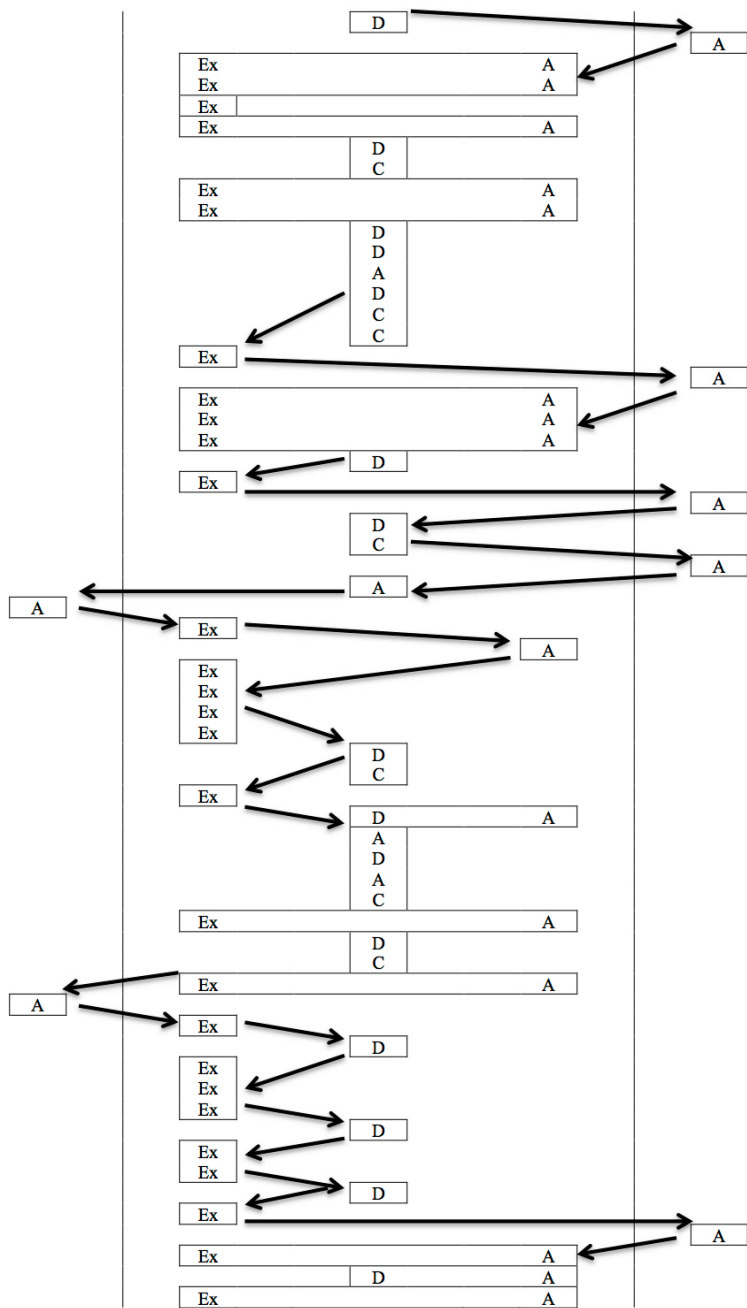

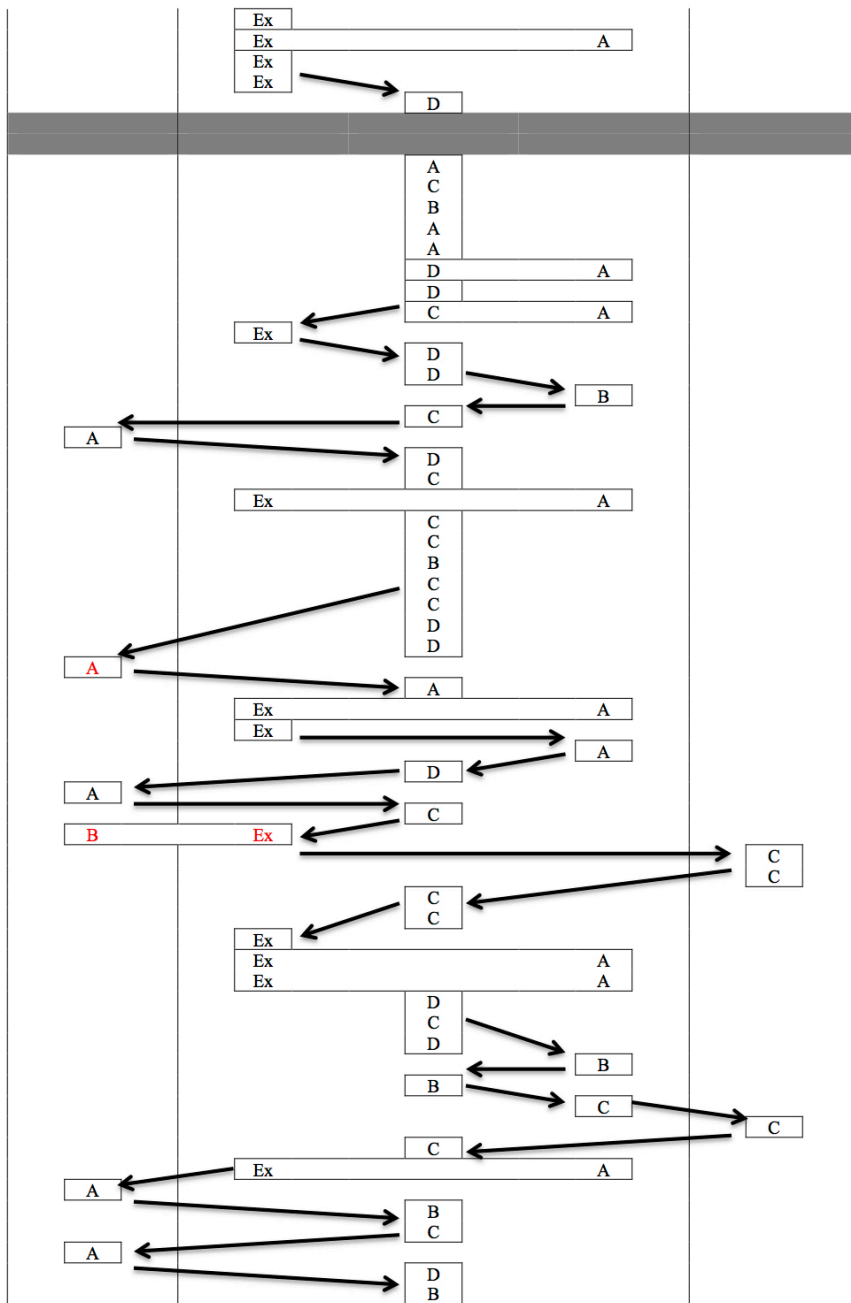

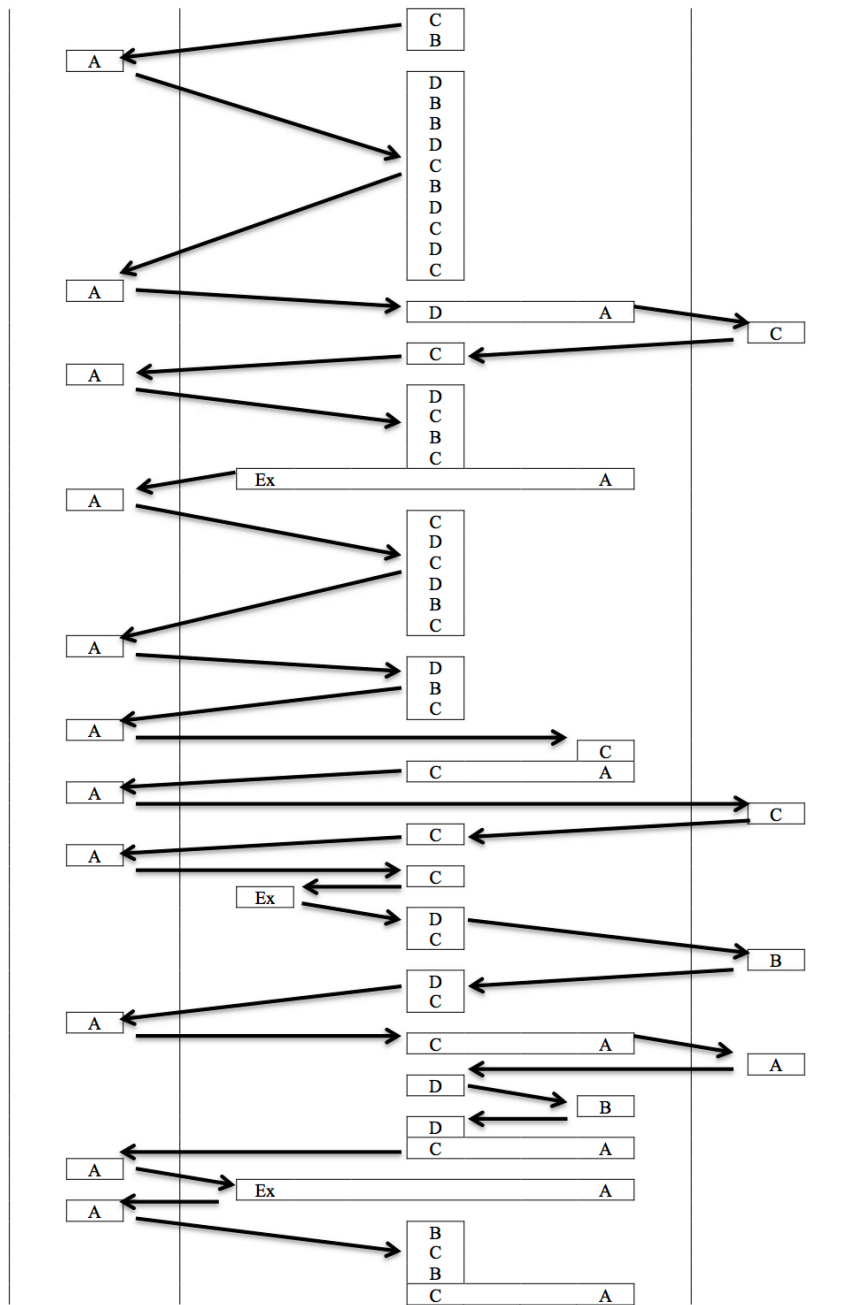

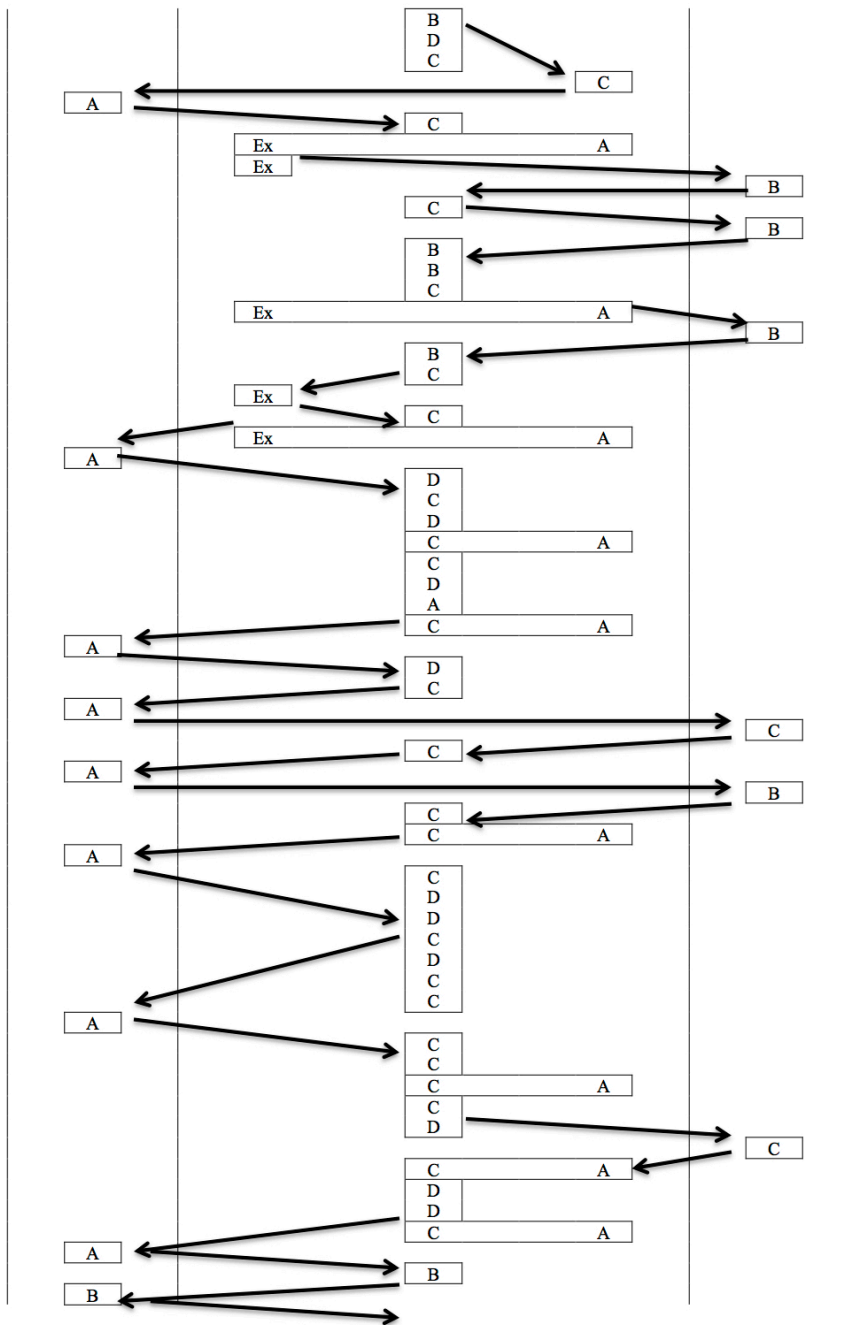

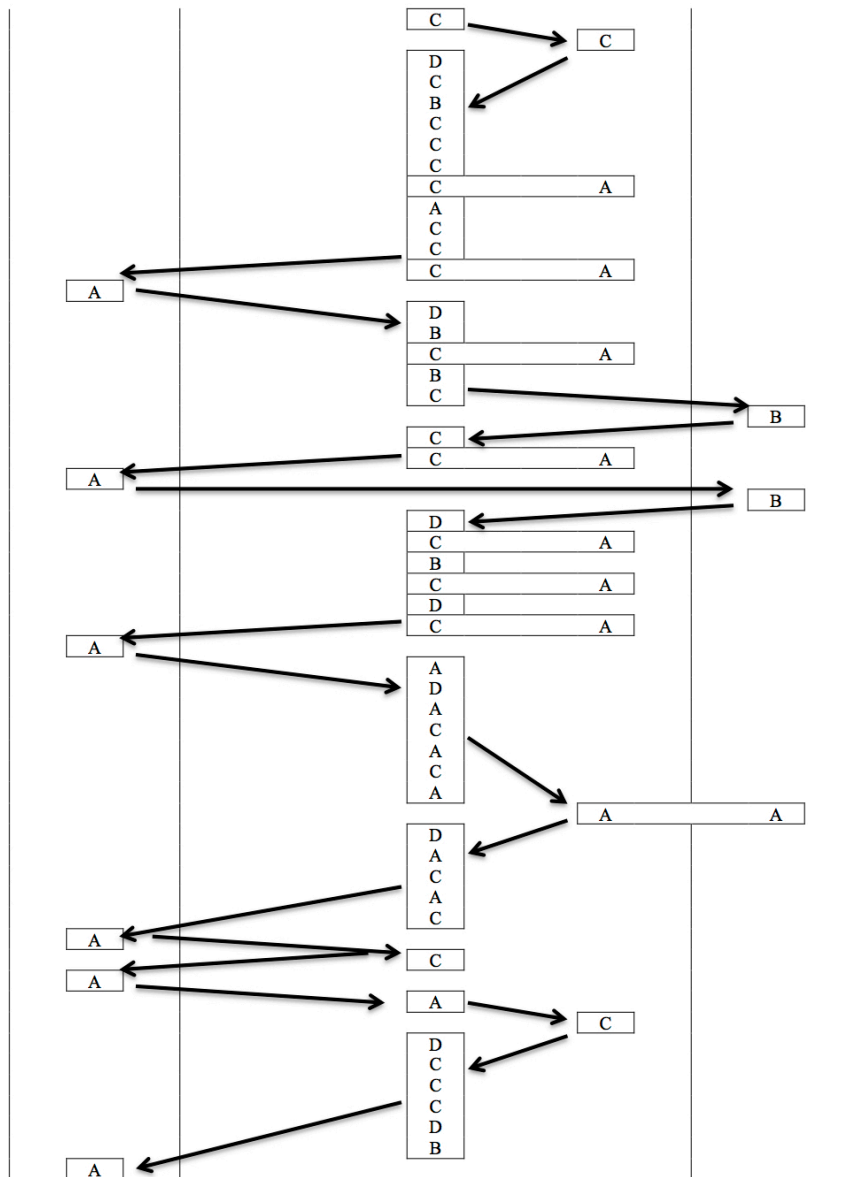

Virtual – Synthesis Phase (levels of scaffolding)

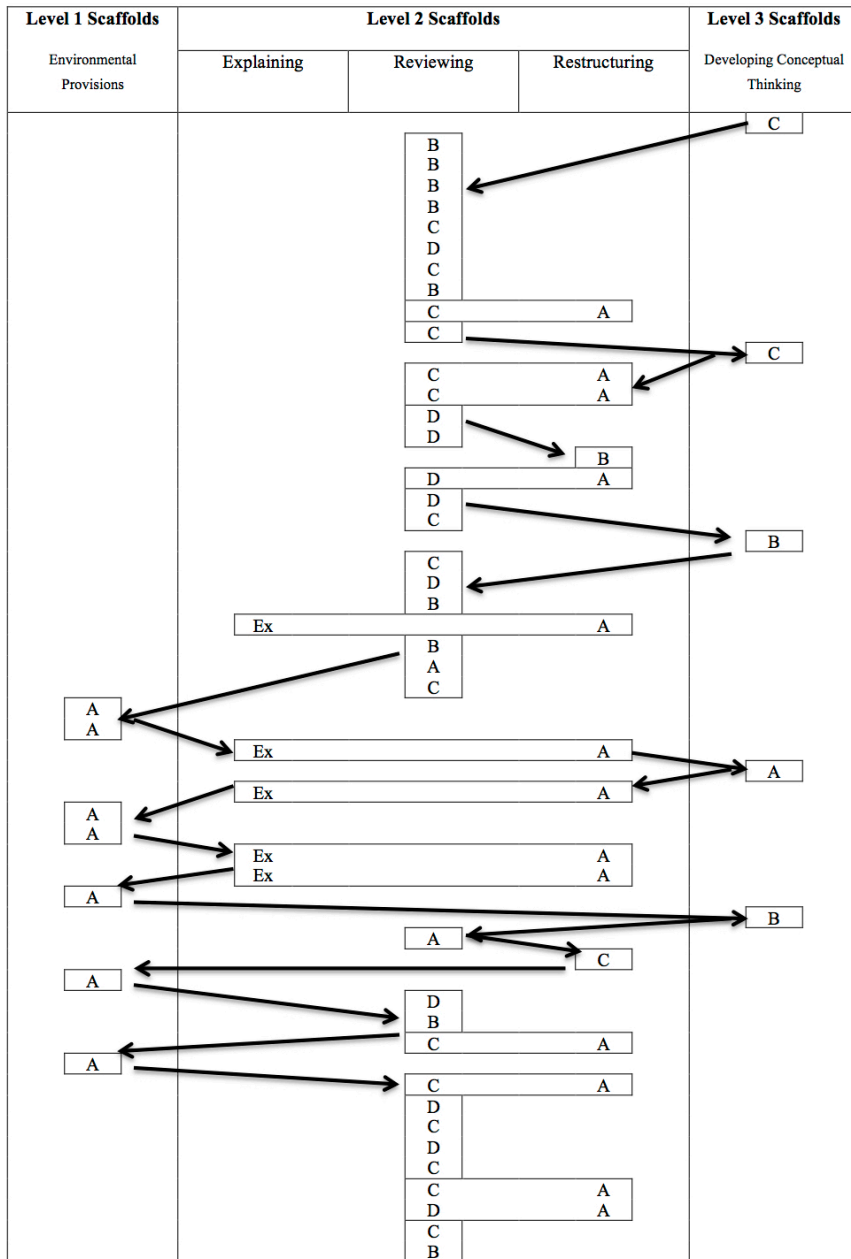

## Appendix J

### Australian Catholic University Ethics Approval Letter



Human Research Ethics Committee  
**Committee Approval Form**

<b>Principal Investigator/Supervisor:</b> Professor Elizabeth Warren
<b>Co-Investigators:</b> N/A
<b>Student Researcher:</b> : Ns Peta Spencer

<b>Ethics approval has been granted for the following project:</b> Young disadvantaged students' experience in mathematics: An exploration of external representations (concrete versus virtual) and learning spatial concepts. (An Exploration of Geometry Concept Learning)
<b>for the period:</b> 24/07/2014 - 08/12/2014
<b>Human Research Ethics Committee (HREC) Register Number:</b> 2014 206Q

**Special Condition/s of Approval**

***Prior to commencement of your research***, the following permissions are required to be submitted to the ACU HREC:

Catholic Education Office and School Principal permissions required.

The following **standard** conditions as stipulated in the *National Statement on Ethical Conduct in Research Involving Humans (2007)* apply:

- (i) that Principal Investigators / Supervisors provide, on the form supplied by the Human Research Ethics Committee, annual reports on matters such as:
  - security of records
  - compliance with approved consent procedures and documentation
  - compliance with special conditions, and
  
- (ii) that researchers report to the HREC immediately any matter that might affect the ethical acceptability of the protocol, such as:
  - proposed changes to the protocol
  - unforeseen circumstances or events
  - adverse effects on participants

The HREC will conduct an audit each year of all projects deemed to be of more than low risk. There will also be random audits of a sample of projects considered to be of negligible risk and low risk on all campuses each year.

Within one month of the conclusion of the project, researchers are required to complete a *Final Report Form* and submit it to the local Research Services Officer.

If the project continues for more than one year, researchers are required to complete an *Annual Progress Report Form* and submit it to the local Research Services Officer within one month of the anniversary date of the ethics approval.

Signed: ..... Date: .... 24/07/2014.....  
(Research Services Officer, McAuley Campus)

Q:\Ethics Forms 2010\Approval Form.doc

## Appendix K

### Brisbane Catholic Education Ethics Approval Letter



**Catholic Education**  
**Archdiocese of Brisbane**

teaching • challenging • transforming

A11.096 WB:cf ref:139

28 August 2014

Ms Peta Spencer  
12 Foxwood Crt  
Dundowran QLD 4655

Dear Peta

The Brisbane Catholic Education Research Committee has met and considered your application to conduct research, titled "*Young disadvantaged students' experience in mathematics: An exploration of external representations (concrete versus virtual) and learning spatial concepts. (An Exploration of Geometry Concept Learning).*" Approval was granted by the committee for this research to be conducted.

**ALL CORRESPONDENCE:**

Brisbane Catholic Education  
GPO Box 1201  
Brisbane QLD 4001  
Phone: (07) 3033 7000  
Fax: (07) 3844 5101  
www.bne.catholic.edu.au  
ABN 49 991 006 857

The committee did note some concern over the proposed timeline for the study given that this period of time for schools is particularly busy with term 4 and end of year activities.

You will need to provide Mr Garry Montgomery the principal of St Mark's with a copy this approval letter as evidence that your research request has been approved.

Please note that participation in your project is at the discretion of the principal. Should St Mark's not wish to participate, please advise this office the names of any replacement schools that you wish to approach before contacting them.



**OFFICE LOCATIONS:**

**Dutton Park**  
243 Gladstone Road  
Phone: (07) 3033 7000

**West End**  
199 Montague Road  
Phone: (07) 3033 7000

**North Lakes**  
12 Endeavour Blvd  
Phone: (07) 3490 1700

**Springwood**  
5-7 Laurinda Crescent  
Phone: (07) 3440 7900

**Fr Bernard O'Shea  
Inservice Centre, Wilston**  
19 Lovedale St  
Phone: (07) 3033 7111

**Ngutana-Lui Aboriginal and  
Torres Strait Islander Cultural  
Studies Centre, Inala**  
100 Lilac St  
Phone: (07) 3033 7200

It is a requirement of all researchers to provide a full report to Brisbane Catholic Education when finalised. Reference number 139 has been allocated to your project please quote this when making contact with this office.

If you have any further queries, please contact me on 30337 7427.

Best wishes for the successful completion of your research project.

Yours sincerely

**Warren Bath**  
**Executive Officer**  
**Catholic Education**  
**Archdiocese of Brisbane**

Copy: Professor Elizabeth Warren



## Appendix L

### Information Letter to the Principal



### PARTICIPANT INFORMATION LETTER (Principal)

**PROJECT TITLE: An Exploration of Geometry Concept Learning**  
**PRINCIPAL INVESTIGATOR: Elizabeth Warren**  
**STUDENT RESEARCHER: Peta Spencer**  
**STUDENT'S DEGREE: Doctor of Philosophy**

Dear Participant,

Your teachers and students are invited to participate in the research project described below.

***What is the project about?***

The aim of the study is to investigate the influence of concrete and virtual manipulative use on students' spatial learning within the mathematics classroom. The objectives of the study are to:

1. Research how students in this school engage in the learning of spatial concepts.
2. Examine the role of concrete and virtual manipulatives in the mathematics classroom within these contexts.
3. Investigate what assists students in this school to be motivated to engage in mathematics learning.

The benefits of this study are:

- Developing a better understanding as to how students in this school learn spatial concepts, which in turn will inform teaching practice.
- Providing insights into the influence of concrete and virtual manipulative use on students' learning of spatial concepts.

***Who is undertaking the project?***

This project is being conducted by Peta Spencer and will form the basis for the degree of Doctor of Philosophy at Australian Catholic University under the supervision of Professor Elizabeth Warren.

***Are there any risks associated with participating in this project?***

There are no foreseeable risks associated with participating in this study.

**What will I be asked to do?**

Participants will be asked to:

**Teachers**

- *Allow observation of their classroom teaching to assist the researcher in building a rapport with students, as well as, the teaching approaches and behaviour management techniques already used within the classroom*
- *Observe the teaching of six 45-minute lessons by the research during class time and provide feedback on the lessons and students interactions*
- *Participate in a short 20-minute debrief at the conclusion of the study*

**Students**

- *Participate in pre, post and post-post testing including spatial knowledge tests and a motivational questionnaire. Each test takes approximately 20 minutes and will be conducted in class by the researcher.*
- *Participate in six 45-minute mathematic lessons using hands-on concrete manipulatives and virtual manipulatives (iPads). These lessons will be conducted during class time by the researcher and will be digitally recorded.*
- *Participate in a 20-minute one-on-one semi-structured interview focusing on the use of concrete and virtual manipulatives to assist students' learning of spatial concepts. These interviews will also be digitally recorded.*

**What are the benefits of the research project?**

It is envisaged that this exploration will provide an understanding as to how students use different manipulatives to influence their spatial learning and their motivation to learn mathematics. As there is currently little research in this area, this study has the potential to inform education systems how to best support and engage these learners in mathematical learning.

**Can I withdraw from the study?**

Participation in this study is completely voluntary. Teachers and students are not under any obligation to participate. If they agree to participate, they can withdraw from the study at any time without adverse consequences.

**Will anyone else know the results of the project?**

The results from this study will be published in research journal articles. The data collected will be identifiable to the researcher but confidentiality will be maintained. Participants will be non-identifiable in all publications, as pseudonyms will be given to participants. Data will be stored in a locked file at ACU.

**Will I be able to find out the results of the project?**

Results of the project will be provided on request.

**Who do I contact if I have questions about the project?**

Any questions regarding this project should be directed to the Professor Elizabeth Warren (telephone 3623 7218) in the School of Education, McAuley Campus, Banyo.

**What if I have a complaint or any concerns?**

The study has been reviewed by the Human Research Ethics Committee at Australian Catholic University (review number 2014 xxxx). If you have any complaints or concerns about the conduct of the project, you may write to the Manager of the Human Research Ethics Committee care of the Office of the Deputy Vice Chancellor (Research).

Manager, Ethics  
c/o Office of the Deputy Vice Chancellor (Research)  
Australian Catholic University  
North Sydney Campus  
PO Box 968  
NORTH SYDNEY, NSW 2059  
Ph.: 02 9739 2519  
Fax: 02 9739 2870  
Email: [res.ethics@acu.edu.au](mailto:res.ethics@acu.edu.au)

Any complaint or concern will be treated in confidence and fully investigated. You will be informed of the outcome.

**I want to participate! How do I sign up?**

If you agree to allow your teachers and students to participate in this study, please ensure that you sign both copies of the consent form and return the researchers copy to the researcher.

Yours sincerely,



**Peta Spencer**



**Elizabeth Warren**

# Appendix M

## Consent Form for the Principal



PRINCIPAL CONSENT FORM  
*Copy for Participant to Keep*

TITLE OF PROJECT: **An Exploration of Geometry Concept Learning**  
PRINCIPAL INVESTIGATOR: **Elizabeth Warren** .....  
STUDENT RESEARCHER: **Peta Spencer**.....

I ..... (the participant) have read (or, where appropriate, have had read to me) and understood the information provided in the Letter to Participants. Any questions I have asked have been answered to my satisfaction. I agree to participate in the study in which my teachers and students will participate in:

Teachers:

- Being observed in mathematics lessons by the researcher
- Observations on the mathematics lessons taught by the researcher
- Participate in a 20-minute debriefing session on the conclusion of the study

Students:

- Participate in pre, post and post-post testing of approximately 20 minutes
- Participate in six 45-minute mathematics lessons taught by the researcher
- Participate in a 20-minute one-on-one interview with the researcher

I understand that the above will be digitally recorded. I also realise that I can withdraw my consent at any time without adverse consequences. I agree that research data collected for the study may be published or may be provided to other researchers in a form that does not identify me, my school, teachers or students in any way.

NAME OF PARTICIPANT: .....

SIGNATURE .....

DATE .....

SIGNATURE OF PRINCIPAL INVESTIGATOR:.....

*Elizabeth Warren*

DATE: 29-07-2014 .....

SIGNATURE OF STUDENT RESEARCHER: .....

*Peta Spencer*

DATE: 29-07-2014 .....

## Appendix N

### Information Letter to the Teacher



#### PARTICIPANT INFORMATION LETTER (Teacher)

**PROJECT TITLE: An Exploration of Geometry Concept Learning**  
**PRINCIPAL INVESTIGATOR: Elizabeth Warren**  
**STUDENT RESEARCHER: Peta Spencer**  
**STUDENT'S DEGREE: Doctor of Philosophy**

Dear Participant,

You are invited to participate in the research project described below.

***What is the project about?***

The aim of the study is to investigate the influence of concrete and virtual manipulative use on students' spatial learning within the mathematics classroom. The objectives of the study are to:

1. Research how students in this school engage in the learning of spatial concepts.
2. Examine the role of concrete and virtual manipulatives in the mathematics classroom within these contexts.
3. Investigate what assists students in this school to be motivated to engage in mathematics learning.

The benefits of this study are:

- Developing a better understanding as to how students in this school learn spatial concepts, which in turn will inform teaching practice.
- Providing insights into the influence of concrete and virtual manipulative use on students' learning of spatial concepts.

***Who is undertaking the project?***

This project is being conducted by Peta Spencer and will form the basis for the degree of Doctor of Philosophy at Australian Catholic University under the supervision of Professor Elizabeth Warren.

***Are there any risks associated with participating in this project?***

There are no foreseeable risks associated with participating in this study. If at anytime you feel overwhelmed, please contact your school counsellor or Lifeline (free call 13 11 14).

**What will I be asked to do?**

Participants will be asked to:

- Allow observation of their classroom teaching to assist the researcher in building a rapport with students, as well as, the teaching approaches and behaviour management techniques already used within the classroom
- Observe the teaching of six 45-minute lessons by the research during class time and provide feedback on the lessons and students interactions
- Participate in a short 20-minute debrief at the conclusion of the study

**What are the benefits of the research project?**

It is envisaged that this exploration will provide an understanding as to how students use different manipulatives to influence their spatial learning and their motivation to learn mathematics. As there is currently little research in this area, this study has the potential to inform education systems how to best support and engage these learners in mathematical learning.

**Can I withdraw from the study?**

Participation in this study is completely voluntary. You are not under any obligation to participate. If you agree to participate, you can withdraw from the study at any time without adverse consequences.

**Will anyone else know the results of the project?**

The results from this study will be published in research journal articles. The data collected will be identifiable to the researcher but confidentiality will be maintained. Participants will be non-identifiable in all publications, as pseudonyms will be given to participants. Data will be stored in a locked file at ACU.

**Will I be able to find out the results of the project?**

Results of the project will be provided on request.

**Who do I contact if I have questions about the project?**

Any questions regarding this project should be directed to the Professor Elizabeth Warren (telephone 3623 7218) in the School of Education, McAuley Campus, Banyo.

**What if I have a complaint or any concerns?**

The study has been reviewed by the Human Research Ethics Committee at Australian Catholic University (review number 2014 xxxx). If you have any complaints or concerns about the conduct of the project, you may write to the Manager of the Human Research Ethics Committee care of the Office of the Deputy Vice Chancellor (Research).

Manager, Ethics  
c/o Office of the Deputy Vice Chancellor (Research)  
Australian Catholic University  
North Sydney Campus  
PO Box 968  
NORTH SYDNEY, NSW 2059  
Ph.: 02 9739 2519  
Fax: 02 9739 2870

V.20140203

2

Email: [res.ethics@acu.edu.au](mailto:res.ethics@acu.edu.au)

Any complaint or concern will be treated in confidence and fully investigated. You will be informed of the outcome.

***I want to participate! How do I sign up?***

If you agree to participate in this study, please ensure that you sign both copies of the consent form and return the researchers copy to the researcher.

Yours sincerely,



**Peta Spencer**



**Elizabeth Warren**

**Appendix O**  
**Consent Form for the Teacher**



---

TEACHER CONSENT FORM  
*Copy for Participant to Keep*

TITLE OF PROJECT: **An Exploration of Geometry Concept Learning**

PRINCIPAL INVESTIGATOR: **Elizabeth Warren** .....

STUDENT RESEARCHER: **Peta Spencer** .....

I ..... *(the participant)* have read *(or, where appropriate, have had read to me)* and understood the information provided in the Letter to Participants. Any questions I have asked have been answered to my satisfaction. I agree to participate in:

- Being observed in mathematics lessons by the researcher
- Observations on the mathematics lessons taught by the researcher
- Participate in a 20-minute debriefing session on the conclusion of the study

I realise that I can withdraw my consent at any time without adverse consequences. I agree that research data collected for the study may be published or may be provided to other researchers in a form that does not identify me in any way.

NAME OF PARTICIPANT: .....

SIGNATURE .....

DATE .....

SIGNATURE OF PRINCIPAL INVESTIGATOR: .....

*Elizabeth Warren*

DATE: 29-07-2014 .....

SIGNATURE OF STUDENT RESEARCHER: .....

*Peta Spencer*

DATE: 29-07-2014 .....



## Appendix P

### Information Letter to the Student



#### PARTICIPANT INFORMATION LETTER (Student)

**PROJECT TITLE: An Exploration of Geometry Concept Learning**

**PRINCIPAL INVESTIGATOR: Elizabeth Warren**

**STUDENT RESEARCHER: Peta Spencer**

**STUDENT'S DEGREE: Doctor of Philosophy**

Dear Participant,

Your child is invited to participate in the research project described below.

***What is the project about?***

The aim of the study is to investigate the influence of concrete and virtual manipulative use on students' spatial learning within the mathematics classroom. The objectives of the study are to:

1. Research how students in this school engage in the learning of spatial concepts.
2. Examine the role of concrete and virtual manipulatives in the mathematics classroom within these contexts.
3. Investigate what assists students in this school to be motivated to engage in mathematics learning.

The benefits of this study are:

- Developing a better understanding as to how students in this school learn spatial concepts, which in turn will inform teaching practice.
- Providing insights into the influence of concrete and virtual manipulative use on students' learning of spatial concepts.

***Who is undertaking the project?***

This project is being conducted by Peta Spencer and will form the basis for the degree of Doctor of Philosophy at Australian Catholic University under the supervision of Professor Elizabeth Warren.

***Are there any risks associated with participating in this project?***

There are no foreseeable risks associated with participating in this study. If at anytime your child feels overwhelmed, please talk to your school counsellor or contact Kids Helpline (1800 55 1800).

**What will I be asked to do?**

Participants will be asked to:

- *Participate in pre, post and post-post testing including spatial knowledge tests and a motivational questionnaire. Each test takes approximately 20 minutes and will be conducted in class by the researcher.*
- *Participate in six 45-minute mathematic lessons using hands-on concrete manipulatives and virtual manipulatives (iPads). These lessons will be conducted during class time by the researcher and will be digitally recorded.*
- *Participate in a 20-minute one-on-one semi-structured interview focusing on the use of concrete and virtual manipulates to assist students' learning of spatial concepts. These interviews will also be digitally recorded.*

**What are the benefits of the research project?**

It is envisaged that this exploration will provide an understanding as to how students use different manipulatives to influence their spatial learning and their motivation to learn mathematics. As there is currently little research in this area, this study has the potential to inform education systems how to best support and engage these learners in mathematical learning.

**Can I withdraw from the study?**

Participation in this study is completely voluntary. Your child is not under any obligation to participate. If you agree for your child to participate, you can withdraw them from the study at any time without adverse consequences.

**Will anyone else know the results of the project?**

The results from this study will be published in research journal articles. The data collected will be identifiable to the researcher but confidentiality will be maintained. Participants will be non-identifiable in all publications, as pseudonyms will be given to participants. Data will be stored in a locked file at ACU.

**Will I be able to find out the results of the project?**

Results of the project will be provided on request.

**Who do I contact if I have questions about the project?**

Any questions regarding this project should be directed to the Professor Elizabeth Warren (telephone 3623 7218) in the School of Education, McAuley Campus, Banyo.

**What if I have a complaint or any concerns?**

The study has been reviewed by the Human Research Ethics Committee at Australian Catholic University (review number 2014 xxxx). If you have any complaints or concerns about the conduct of the project, you may write to the Manager of the Human Research Ethics Committee care of the Office of the Deputy Vice Chancellor (Research).

Manager, Ethics  
c/o Office of the Deputy Vice Chancellor (Research)  
Australian Catholic University  
North Sydney Campus

V.20140203

2

PO Box 968  
NORTH SYDNEY, NSW 2059  
Ph.: 02 9739 2519  
Fax: 02 9739 2870  
Email: [res.ethics@acu.edu.au](mailto:res.ethics@acu.edu.au)

Any complaint or concern will be treated in confidence and fully investigated. You will be informed of the outcome.

***I want to participate! How do I sign up?***

If you agree to allow your child to participate in this study, please ensure that you sign both copies of the consent form and return the researchers copy to the classroom teacher.

Yours sincerely,



**Peta Spencer**



**Elizabeth Warren**

# Appendix Q

## Consent Form for the Student



PARENT/GUARDIAN CONSENT FORM  
*Copy for Participant to Keep*

TITLE OF PROJECT: **An Exploration of Geometry Concept Learning**

PRINCIPAL INVESTIGATOR: **Elizabeth Warren** .....

STUDENT RESEARCHER: **Peta Spencer** .....

I ..... (*the parent/guardian*) have read (*or, where appropriate, have had read to me*) and understood the information provided in the Letter to the Participants. Any questions I have asked have been answered to my satisfaction. I agree that my child, nominated below, may participate in:

- Participate in pre, post and post-post testing of approximately 20 minutes each
- Participate in six 45-minute mathematics lessons taught by the researcher
- Participate in a 20-minute one-on-one interview with the researcher

I understand that the lessons and interview will be digitally recorded. I also realise that I can withdraw my consent at any time without adverse consequences. I agree that research data collected for the study may be published or may be provided to other researchers in a form that does not identify my child in any way.

NAME OF PARENT/GUARDIAN: .....

SIGNATURE ..... DATE: .....

NAME OF CHILD .....

SIGNATURE OF PRINCIPAL INVESTIGATOR: .....

*Elizabeth Warren*

DATE: 29-07-2014

SIGNATURE OF STUDENT RESEARCHER: .....

*Peta Spencer*

DATE: 29-07-2014

## Appendix R

### Teacher's and Students' Frequency of Difference *Special Keywords*

#### Teacher Range of Special Keywords (PM Class)

Oriente	Tally	Enhance: Explicit Modeling	Tally	Enhance: Guided Application	Tally	Synthesise	Tally
Position	3	Front	2	Side	5	Positions	7
Front	2	Side	4	Left	6	Point of	1
Back	1	Top	7	Top	25	reference	
Top	4	Shape	1	Next to	7	Graph	2
Bottom	2	Square	1	beside	4	Top	6
Area	1	Behind	3	Above	1	Bottom	1
Closer	2	Around	1	Below	2	Left	1
Side	2	High	8	Position(al)	11	Right	1
		Back	1	Bottom	8	Front	1
				Angles	1	Rows	1
				Behind	6		
				Front	4		
				Back	1		
				Edge	1		
				Underneath	1		
				Right	3		
				In-between	1		
8	17	9 (6 new)	28	17 (10 new)	87	9 (3 new)	21

## Teacher Range of Special Keywords (VM Class)

Orientate	Tally	Enhance: Explicit Modeling	Tally	Enhance: Guided Application	Tally	Synthesise	Tally
3D blocks	3	Over	1	Higher	8	First	1
sides	3	View	9	Toward	1	Up	2
front	2	Down	1	Position(al)	19	View	14
bottom	2	Corner	2	View	15	Position(al)	3
back	1	High	12	Line	1	Front	6
turn	2	Next	14	Across	1	Down	1
rotated	1	Behind	6	Left	5	Second	1
angles	1	Position(al)	11	Right	5	Before	1
top	1	Upside-	1	Squares	2	Around	8
down	2	down		Rows	1	Back	4
cube	2	Stack	3	Second	1	Top	2
left	3	Top	4	3D	2	High	2
right	2	Left	2	visualization	1	Turn	11
shape	2	Third	2	smallest	1	Far	5
position	4	Across	5	turn	4	Degrees	3
above	1	Middle	3	angle	3	Flipping	1
below	1	Row	23	numbers	4	Full (turn)	2
in-	1	Front	7	sideways	2	Half	1
between		Second	1	direction	1	Quarter	1
		Side	7	diagram	1	Second	2
		Takeaway	1	front	6	Row	1
		Back	2	back	6	Cubes	3
		Last	2	down	1	3D	2
		Underneath	1	bottom	1	shapes	2
		Bottom	2	big	1		
		Above	2	behind	3		
		Right	4	forward	1		
		First	5	last	1		
		Tall	5	long	2		
		line	1	little	2		
				over	3		
				more	1		
				top	5		
				beside	1		
				shapes	1		
				triangle	1		
				middle	2		
18	34	29 (18 new)	139	37 (13 new)	116	24 (6 new)	79

### Student Range of Special Keywords (PM Class)

Orientate	Tally	Enhance: Explicit Modeling	Tally	Enhance: Guided Application	Tally	Synthesise	Tally
Position	2	Top	4	Left	6	Direction	1
Front	2	Front	1	Top	9	Position(al)	2
Back	1	Side	1	Beside	3	Top	3
Top	2			Above	2	Left	1
Bottom	2			Bottom	6	Right	1
				Corner	2	Front	1
				Middle	1	Graph	1
				Next	3		
				Position	2		
				Front	1		
				Back	1		
				Side	3		
				Right	1		
5		3 (1 new)		13 (7 new)		7 (2 new)	

### Student Range of Special Keywords (VM Class)

Orientate	Tally	Enhance: Explicit Modeling	Tally	Enhance: Guided Application	Tally	Synthesise	Tally
3D blocks	2	Behind	1	Right	7	More	1
forward		Position	1	Views	2	Little	1
back	1	Next	1	Square	2	First	2
top	3	Row	1	Position(al)	4	View	2
bottom	1	Back	1	Row	1	Part	1
turn	3	Higher	1	Little/small	4	Under	1
around	2	Front	1	3D	1	Turn	2
front	1	behind	1	side	1	Around	2
square	1	Top	3	top	2	Degrees	1
sides	1	Right	3	turn	2	Half	1
cube	1	Side	2	front	4	Row	1
left	1	Pole	1	sections	2	Middle	1
right	2	Bottom	2	highest	6	Second	1
down	2	Left	1	back	1	Cubes	1
shape	1	Corner	4	first	1	Side	1
position	1	Near	2	numbers	4	Front	1
	1	Middle	6	down	3	3D shapes	1
		Underneath	1	bottom	1		
				behind	2		
				over	4		
				long	1		
				tilt	1		
				triangle	1		
				left	5		
				switched	1		
				same	1		
16		14 (4 new)		30 (15 new)		17 (5 new)	