

<https://helda.helsinki.fi>

Square functions and radonifying operators

Hytönen, Tuomas

Springer-Verlag

2018

Hytönen , T , van Neerven , J , Veraar , M & Weis , L 2018 , Square functions and radonifying operators . in ANALYSIS IN BANACH SPACES : VOL II: PROBABILISTIC METHODS AND OPERATOR THEORY . vol. 67 , Ergebnisse der Mathematik und ihrer Grenzgebiete 3 Folge , vol. 67 , Springer-Verlag , HEIDELBERGER PLATZ 3, D-14197 BERLIN, GERMANY , pp. 251-358 . https://doi.org/10.1007/978-3-319-69808-3_4

<http://hdl.handle.net/10138/321713>

https://doi.org/10.1007/978-3-319-69808-3_4

acceptedVersion

Downloaded from Helda, University of Helsinki institutional repository.

This is an electronic reprint of the original article.

This reprint may differ from the original in pagination and typographic detail.

Please cite the original version.

Tuomas Hytönen
Jan van Neerven
Mark Veraar
Lutz Weis

Analysis in Banach Spaces

Volume II
Probabilistic Methods and Operator Theory

September 15, 2017

Dedicated to the memory of

Nigel J. Kalton (1946–2010)

&

Alan G. R. McIntosh (1942–2016)

Preface

In Volume I of ‘Analysis in Banach spaces’ we presented essential techniques for the analysis of Banach space-valued functions, from integration theory and martingale inequalities to the extension of classical singular integral operators, such as the Hilbert transform and Mihlin Fourier multiplier operators, from L^p -spaces of scalar-valued functions to L^p -spaces of functions taking values in UMD Banach spaces.

In the present volume we concentrate on a second, closely related question central to the theory of evolution equations, namely how to extend various classical L^2 -estimates and related Hilbert space techniques to the Banach space setting, in particular to the L^p -scale.

Already in the mid-1980s, motivated by the square root problem for sectorial operators, Alan McIntosh forged the classical theory of square functions in Fourier Analysis, pioneered by Paley, Marcinkiewicz–Zygmund, and Stein, into a powerful tool for the study of general sectorial operators on Hilbert spaces. Just as one can view Harmonic Analysis as the ‘spectral theory of the Laplacian’ (Strichartz), McIntosh’s square function techniques for sectorial operators capture essential singular integral estimates still available in this more general setting. Extension of these estimates to the L^p -setting requires a substitute for the basic Hilbertian orthogonality techniques on which they rely. The theory of random sums, in particular Rademacher sums and Gaussian sums, originally developed in the context of Probability Theory in Banach spaces and the Geometry of Banach spaces, provides just that. The fine properties of Banach space-valued random sums are intimately connected with various probabilistic notions such as type, cotype, and K -convexity which often take on the role of geometrical properties of the classical L^p -spaces that are explicit or implicit in the treatment of classical inequalities. The first two chapters of this volume present those aspects that are relevant to our purpose. For a fuller treatment of this fascinating topic the reader is referred to the rich literature on the Geometry of Banach spaces and Probability in Banach spaces.

Volume I already provided a first glance into the programme outlined above when we proved an operator-valued version of the Mihlin multiplier theorem by replacing the uniform boundedness condition on certain operator families appearing in the conditions of the Mihlin theorem by the stricter requirement of R -boundedness. This magic wand can be applied to a surprising number of operator theoretic Hilbert space results. This volume presents a wealth of analytical methods that allow one to verify the R -boundedness of many sets of classical operators relevant in applications to Harmonic Analysis and Stochastic Analysis.

A second tool to extend Hilbert space techniques to a Banach space setting consists of replacing L^2 -spaces by generalised square function estimates which, in an abstract Banach space setting, can be alternatively described in an operator-theoretic way through the theory of radonifying operators. This class of operators connects the theory of Banach space-valued Gaussian random sums to methods from operator theory in a rather direct way, thus paving the way to substantial applications in vector-valued Harmonic Analysis and Stochastic Analysis. On an ‘operational level’, they display the same function space properties (such as versions of Hölder’s inequality, Fatou’s lemma, and Fubini’s theorem) as their classical counterparts do.

With these tools at hand we present a far reaching extension of the theory of the H^∞ -functional calculus on Hilbert spaces to the L^p -setting, including characterisations of its boundedness in terms of square function estimates, R -boundedness and dilations. From these flow the results which made the H^∞ -functional calculus so useful in the theory of evolution equations in L^p -spaces: the operator sum method, an operator valued calculus and a variety of techniques to verify the boundedness of the H^∞ -functional calculus for most differential operators of importance in applications.

The randomisation techniques and their operator theoretic counterparts worked out in the present book will also set the stage for Volume III. There we will present vector-valued function spaces, complete our treatment of vector valued harmonic analysis and discuss the theory of operator valued Itô integrals in UMD Banach spaces and their application to maximal regularity estimates for stochastic evolution equations with Gaussian noise. It is here that generalised square functions display their full power as they furnish a close link between stochastic estimates such as the vector valued Burkholder–Davis–Gundy inequalities and harmonic analytic properties of the underlying partial differential operator, encoded in its H^∞ -calculus.

*

It is perhaps interesting to notice a change of generation in the contents of this volume compared to Volume I. With important exceptions mostly on the scale of subsections, the main body of the material presented in Volume I may be considered ‘classical’ by now. In fact, the following subjective definition of ‘classical’ has been proposed by D. Cruz-Uribe (private communication): “Anything that was proved before I started graduate school.” By a three-

quarter majority within the present authorship, this definition would render all results obtained by mid-1980's 'classical'.

The main results of the first two chapters on random sums and their connections to Banach space theory are still largely classical in this sense. However, an important turning point occurs in the beginning of Chapter 8, dedicated to the notion of R -boundedness. Although the deep roots of this theory are older, its systematic development only begins in the 1990's and reaches its full bloom around and after the turn of the millennium; some basic questions related to the comparison of R -boundedness with related notions were settled as recently as 2016. Likewise, while the foundations of the theory of radonifying operators are certainly classical, their interpretation and systematic exploitation as generalised square functions in Chapter 9 is a successful creation of the 2000's. As for the theory of the H^∞ -calculus developed in the last chapter, only the groundwork in a Hilbert space context is classical. Its extension to Banach spaces is more recent, and especially its fundamental connections with the generalised square functions, a key theme of our treatment, have only been revealed during this century.

*

Two stylistic conventions of Volume I will stay in force in the present volume as well: Most of the time, we are quite explicit with the constants appearing in our estimates, and we especially try to keep track of the dependence on the main parameters involved. Some of these explicit quantitative formulations appear here for the first time. We also pay more attention than many texts to the impact of the underlying scalar field (real or complex) on the results under consideration. A careful distinction between linear and conjugate-linear duality is particularly critical to the correct formulation of some key results concerning the generalised square functions, which are among the main characters of the present volume.

*

This project was initiated in Delft and Karlsruhe in 2008. Critical to its eventual progress was the possibility of intensive joint working periods in the serenity provided by the Banach Center in Będlewo (2012), Mathematisches Forschungsinstitut Oberwolfach (2013), Stiftsgut Keysermühle in Klingenbergmünster (2014 and 2015), Hotel 't Paviljoen in Rhenen (2015), and Buitengoed de Uylenburg in Delfgauw (2017). All four of us also met three times in Helsinki (2014, 2016 and 2017), and a number of additional working sessions were held by subgroups of the author team. One of us (J.v.N.) wishes to thank Marta Sanz-Solé for her hospitality during a sabbatical leave at the University of Barcelona in 2013.

Preliminary versions of parts of the material were presented in advanced courses and lecture series at various international venues and in seminars at our departments, and we would like to thank the students and colleagues who attended these events for feedback that shaped and improved the final form of the text. Special thanks go to Alex Amenta, Markus Antoni, Sonja Cox,

Chiara Gallarati, Fabian Hornung, Luca Hornung, Nick Lindemulder, Emiel Loris, Bas Nieraeth, Jan Rozendaal, Emil Vuorinen, and Ivan Yaroslavtsev who did detailed readings of portions of this book. Needless to say, we take full responsibility for any remaining errors. A list with errata will be maintained on our personal websites. We wish to thank Klaas Pieter Hart for L^AT_EX support.

During the writing of this book, we have benefited from external funding by the European Research Council (ERC Starting Grant “AnProb” to T.H.), the Academy of Finland (grants 130166 and 133264 to T.H., and the Centre of Excellence in Analysis and Dynamics, of which T.H. is a member), the Netherlands Organisation for Scientific research (NWO) (VIDI grant 639.032.201 and VICI grant 639.033.604 to J.v.N. and VENI grant 639.031.930 and VIDI grant 639.032.427 to M.V.), and the German Research Foundation (DFG) (Research Training group 1254 and Collaborative Research Center 1173 of which L.W. is a member). We also wish to thank the Banach Center in Będlewo and Mathematisches Forschungsinstitut Oberwolfach for allowing us to spend two highly productive weeks in both wonderful locations.

Delft, Helsinki and Karlsruhe,
September 15, 2017.

Contents

6	Random sums	1
6.1	Basic notions and estimates	2
6.1.a	Symmetric random variables and randomisation	4
6.1.b	Kahane’s contraction principle	9
6.1.c	Norm comparison of different random sums	10
6.1.d	Covariance domination for Gaussian sums	15
6.2	Comparison of different L^p -norms	17
6.2.a	The discrete heat semigroup and hypercontractivity ...	18
6.2.b	Kahane–Khintchine inequalities	21
6.2.c	End-point bounds related to $p = 0$ and $q = \infty$	24
6.3	The random sequence spaces $\varepsilon^p(X)$ and $\gamma^p(X)$	26
6.3.a	Coincidence with square function spaces when $X = L^q$.	28
6.3.b	Dual and bi-dual of $\varepsilon_N^p(X)$ and $\gamma_N^p(X)$	29
6.4	Convergence of random series	33
6.4.a	Itô–Nisio equivalence of different modes of convergence .	33
6.4.b	Boundedness implies convergence if and only if $c_0 \not\subseteq X$.	39
6.5	Comparison of random sums and trigonometric sums	42
6.6	Notes	46
7	Type, cotype, and related properties	53
7.1	Type and cotype	54
7.1.a	Definitions and basic properties	54
7.1.b	Basic examples	56
7.1.c	Type implies cotype	63
7.1.d	Type and cotype for general random sequences	66
7.1.e	Extremality of Gaussians in (co)type 2 spaces	69
7.2	Comparison theorems under finite cotype	73
7.2.a	Summing operators	74
7.2.b	Pisier’s factorisation theorem	75
7.2.c	Contraction principle with function coefficients	79
7.2.d	Equivalence of cotype and Gaussian cotype	81

7.2.e	Finite cotype in Banach lattices	85
7.3	Geometric characterisations	88
7.3.a	Kwapień’s characterisation of type and cotype 2	89
7.3.b	Maurey–Pisier characterisation of non-trivial (co)type	96
7.4	K -convexity	109
7.4.a	Definition and basic properties	109
7.4.b	K -convexity and type	114
7.4.c	K -convexity and duality of the spaces $\varepsilon_N^p(X)$	115
7.4.d	K -convexity and interpolation	118
7.4.e	K -convexity with respect to general random variables	120
7.4.f	Equivalence of K -convexity and non-trivial type	123
7.5	Contraction principles for double random sums	129
7.5.a	Pisier’s contraction property	130
7.5.b	The triangular contraction property	136
7.5.c	Duality and interpolation	140
7.5.d	Gaussian version of Pisier’s contraction property	142
7.5.e	Double random sums in Banach lattices	145
7.6	Notes	146
8	R-boundedness	163
8.1	Basic theory	164
8.1.a	Definition and comparison with related notions	164
8.1.b	Testing R -boundedness with distinct operators	168
8.1.c	First examples: multiplication and averaging operators	170
8.1.d	R -boundedness versus boundedness on $\varepsilon_N^p(X)$	177
8.1.e	Stability of R -boundedness under set operations	178
8.2	Sources of R -boundedness in real analysis	183
8.2.a	Pointwise domination by the maximal operator	183
8.2.b	Inequalities with Muckenhoupt weights	185
8.2.c	Characterisation by weighted inequalities in L^p	187
8.3	Fourier multipliers and R -boundedness	192
8.3.a	Multipliers of bounded variation on the line	192
8.3.b	The Marcinkiewicz multiplier theorem on the line	197
8.3.c	Multipliers of bounded rectangular variation	200
8.3.d	The product-space multiplier theorem	205
8.3.e	Necessity of Pisier’s contraction property	209
8.4	Sources of R -boundedness in operator theory	211
8.4.a	Duality and interpolation	211
8.4.b	Unconditionality	214
8.5	Integral means and smooth functions	217
8.5.a	Integral means I: elementary estimates	217
8.5.b	The range of differentiable and holomorphic functions	221
8.5.c	Integral means II: the effect of type and cotype	225
8.5.d	The range of functions of fractional smoothness	231
8.6	Coincidence of R -boundedness with other notions	234

8.6.a	Coincidence with boundedness implies (co)type 2	234
8.6.b	Coincidence with γ -boundedness implies finite cotype	237
8.7	Notes	241
9	Square functions and radonifying operators	251
9.1	Radonifying operators	252
9.1.a	Heuristics	252
9.1.b	The operator spaces $\gamma_\infty(H, X)$ and $\gamma(H, X)$	254
9.1.c	The ideal property	260
9.1.d	Convergence results	261
9.1.e	Coincidence $\gamma_\infty(H, X) = \gamma(H, X)$ when $c_0 \not\subseteq X$	265
9.1.f	Trace duality	267
9.1.g	Interpolation	269
9.1.h	The indefinite integral and Brownian motion	271
9.2	Functions representing a γ -radonifying operator	275
9.2.a	Definitions and basic properties	275
9.2.b	Square integrability versus γ -radonification	278
9.2.c	Trace duality and the γ -Hölder inequality	282
9.3	Square function characterisations	284
9.3.a	Square functions in L^p -spaces	284
9.3.b	Square functions in Banach function spaces	287
9.4	Function space properties	293
9.4.a	Convergence theorems	293
9.4.b	Fubini-type theorems	296
9.4.c	Partitions, type and cotype	298
9.5	The γ -multiplier theorem	299
9.5.a	Sufficient conditions for pointwise multiplication	300
9.5.b	Necessity of γ -boundedness	303
9.6	Extension theorems	308
9.6.a	General extension results	308
9.6.b	R -bounded extensions via Pisier's contraction property	311
9.6.c	R -bounded extensions via type and cotype	314
9.7	Function space embeddings	320
9.7.a	Embedding Sobolev spaces	321
9.7.b	Embedding Hölder spaces	326
9.7.c	Embeddings involving holomorphic functions	329
9.7.d	Hilbert sequences	337
9.8	Notes	345
10	The H^∞-functional calculus	359
10.1	Sectorial operators	360
10.1.a	Examples	362
10.1.b	Basic properties	364
10.2	Construction of the H^∞ -calculus	368
10.2.a	The Dunford calculus	369

10.2.b	The H^∞ -calculus	379
10.2.c	First examples	388
10.3	R -boundedness of the H^∞ -calculus	398
10.3.a	R -sectoriality	399
10.3.b	The main R -boundedness result	401
10.3.c	Unconditional decompositions associated with A	404
10.3.d	Proof of the main result	406
10.4	Square functions and H^∞ -calculus	413
10.4.a	Discrete square functions	414
10.4.b	Continuous square functions	422
10.4.c	The quadratic H^∞ -calculus	432
10.4.d	Le Merdy's theorem on the angle of the H^∞ -calculus	435
10.5	Necessity of UMD and Pisier's contraction property	440
10.6	The bisectorial H^∞ -calculus	446
10.6.a	Bisectorial operators	446
10.6.b	Basic theory of the bisectorial calculus	449
10.7	Functional calculus for (semi)group generators	451
10.7.a	The Phillips calculus	452
10.7.b	Coifman–Weiss transference theorems	456
10.7.c	Hieber–Prüss theorems on H^∞ -calculus for generators	461
10.7.d	Analytic semigroups of positive contractions on L^p	462
10.8	Notes	468
P	Problems	479
E	Probability theory	487
E.1	Random variables	487
E.1.a	Modes of convergence	488
E.1.b	Independence	491
E.1.c	Characteristic functions	493
E.2	Gaussian variables	495
E.2.a	Multivariate Gaussian variables	498
E.2.b	The central limit theorem	502
E.2.c	The maximum of Gaussian variables	505
E.3	Notes	509
F	Banach lattices	511
F.1	Definitions and basic properties	511
F.2	The Krivine calculus	512
F.3	Lorentz spaces	514
F.4	Notes	517

G	Semigroups of linear operators	519
	G.1 Unbounded linear operators	519
	G.2 C_0 -semigroups	523
	G.3 The inhomogeneous abstract Cauchy problem	531
	G.4 The Hille–Yosida theorem	532
	G.5 Analytic semigroups	536
	G.6 Stone’s theorem	543
	G.7 Notes	545
H	Hardy spaces of holomorphic functions	549
	H.1 Hardy spaces on a strip	549
	H.2 Hardy spaces on a sector	552
	H.3 The Franks–McIntosh decomposition	553
	H.4 Notes	559
I	Akcoglu’s theory of positive contractions on L^p	561
	I.1 Isometric dilations	561
	I.2 Maximal ergodic averages	569
	I.3 Notes	574
J	Muckenhoupt weights	577
	J.1 Weighted boundedness of the maximal operator	577
	J.2 Rubio de Francia’s weighted extrapolation theorem	579
	J.3 Notes	583
	References	585
	Index	610

Symbols and notations

Sets

$\mathbb{N} = \{0, 1, 2, \dots\}$ - non-negative integers

\mathbb{Z} - integers

\mathbb{Q} - rational numbers

\mathbb{R} - real numbers

\mathbb{C} - complex numbers

\mathbb{K} - scalar field (\mathbb{R} or \mathbb{C})

$\overline{\mathbb{Z}} = \mathbb{Z} \cup \{-\infty, \infty\}$ - extended integers

$\mathbb{R}_+ = (0, \infty)$ - positive real line

B_X - open unit ball

S_X - unit sphere

$B(x, r)$ - open ball centred at x with radius r

\mathbb{D} - open unit disc

$\mathbb{S} = \{z \in \mathbb{C} : 0 < \Im z < 1\}$ - unit strip

Σ_ω = open sector of angle ω

$\Sigma_\omega^{\text{bi}}$ = open bisector of angle ω

$\mathbb{T} = \{z \in \mathbb{C} : |z| = 1\}$ - unit circle

Vector spaces

c_0 - space of null sequences

C - space of continuous functions

C_0 - space of continuous functions vanishing at infinity

C^α - space of Hölder continuous functions

C_b - space of bounded continuous functions

C_c - space of continuous functions with compact support

C_c^∞ - space of test functions with compact support

\mathcal{C}^p - Schatten class

$\varepsilon_N(X), \varepsilon(X)$ - Rademacher sequence spaces

$\gamma_N(X), \gamma(X)$ - Gaussian sequence spaces

$\gamma(H, X)$ - space of γ -radonifying operators
 $\gamma(S; X)$ - shorthand for $\gamma(L^2(S), X)$
 $\gamma_\infty(H, X)$ - space of almost summing operators
 $\gamma_\infty(S; X)$ - shorthand for $\gamma_\infty(L^2(S), X)$
 H - Hilbert space
 $H^{s,p}$ - Bessel potential space
 H^p - Hardy space
 $\mathcal{H}(X_0, X_1)$ - space of homomorphic functions on the strip
 ℓ^p - space of p -summable sequences
 ℓ_N^p - space of p -summable finite sequences
 L^p - Lebesgue space
 $L^{p,q}$ - Lorentz space
 $L^{p,\infty}$ - weak- L^p
 $\mathcal{L}(X, Y)$ - space of bounded linear operators
 $\mathfrak{M}L^p(\mathbb{R}^d; X, Y)$ - space of Fourier multipliers
 $\mathfrak{M}(\mathbb{R}^d; X, Y)$ - Mihlin class
 \mathcal{S} - space of Schwartz functions
 \mathcal{S}' - space of tempered distributions
 $W^{k,p}$ - Sobolev space
 $W^{s,p}$ - Sobolev-Slobodetskii space
 X, Y, \dots - Banach spaces
 $X_{\mathbb{C}}$ - complexification
 $X_{\mathbb{C}}^{\gamma,p}$ - Gaussian complexification
 X^*, Y^*, \dots - dual Banach spaces
 X^\odot, Y^\odot, \dots - strongly continuous semigroup dual spaces
 $X \otimes Y$ - tensor product
 $[X_0, X_1]_\theta$ - complex interpolation space
 $(X_0, X_1)_{\theta,p}, (X_0, X_1)_{\theta,p_0,p_1}$ - real interpolation spaces

Measure theory and probability

\mathcal{A} - σ -algebra
 $df_n = f_n - f_{n-1}$ - n th martingale difference
 ϵ_n - signs in \mathbb{K} , i.e., scalars in \mathbb{K} of modulus one
 ϵ_n - Rademacher variables with values in \mathbb{K}
 \mathbb{E} - expectation
 $\mathcal{F}, \mathcal{G}, \dots$ - σ -algebras
 \mathcal{F}_f - collection of sets in \mathcal{F} on which f is integrable
 $\mathbb{E}(\cdot|\cdot)$ - conditional expectation
 γ_n - Gaussian variables
 h_I - Haar function
 μ - measure
 $\|\mu\|$ - variation of a measure
 $(\Omega, \mathcal{A}, \mathbb{P})$ - probability space
 \mathbb{P} - probability measure

r_n - real Rademacher variables
 (S, \mathcal{A}, μ) - measure space
 $\sigma(f, g, \dots)$ - σ -algebra generated by the functions f, g, \dots
 $\sigma(\mathcal{C})$ - σ -algebra generated by the collection \mathcal{C}
 τ - stopping time
 w_α - Walsh function

Norms and pairings

$|\cdot|$ - modulus, Euclidean norm
 $\|\cdot\| = \|\cdot\|_X$ - norm in a Banach space X
 $\|\cdot\|_p = \|\cdot\|_{L^p}$ - L^p -norm
 $\langle \cdot, \cdot \rangle$ - duality
 $(\cdot | \cdot)$ - inner product in a Hilbert space
 $a \cdot b$ - inner product of $a, b \in \mathbb{R}^d$

Operators

A - closed linear operator
 A^* - adjoint operator
 A^\odot - part of A^* in X^\odot
 $D(A)$ - domain of A
 D_j - pre-decomposition
 Δ - Laplace operator
 $\gamma(\mathcal{T})$ - γ -bound of the operator family \mathcal{T}
 $\gamma_p(\mathcal{T})$ - γ -bound of \mathcal{T} with respect to the L^p -norm
 \mathcal{D} - dyadic system
 $\partial_j = \partial/\partial x_j$ - partial derivative with respect to x_j
 ∂^α - partial derivative with multi-index α
 $\mathbb{E}(\cdot | \cdot)$ - conditional expectation
 $\mathcal{F}f$ - Fourier transform
 $\mathcal{F}^{-1}f$ - inverse Fourier transform
 \tilde{H} - Hilbert transform
 \tilde{H} - periodic Hilbert transform
 J_s - Bessel potential operator
 $\ell^2(\mathcal{T})$ - ℓ^2 -bound of the operator family \mathcal{T}
 $\mathcal{L}(X, Y)$ - space of bounded operators from X to Y
 $\mathcal{L}_{\text{so}}(X, Y)$ - idem, endowed with the strong operator topology
 $\mathbf{N}(A)$ - null space of A
 $\mathcal{R}(\mathcal{T})$ - R -bound of the operator family \mathcal{T}
 $\mathcal{R}_p(\mathcal{T})$ - R -bound of \mathcal{T} with respect to the L^p -norm
 $\mathbf{R}(A)$ - range of A
 R_j - j th Riesz transform
 S, T, \dots - bounded linear operators
 $S(t), T(t), \dots$ - semigroup operators
 $S^*(t), T^*(t), \dots$ - adjoint semigroup operators on the dual space X^*

$S^\odot(t), T^\odot(t), \dots$ - their parts in the strongly continuous dual X^\odot
 T^* - adjoint of the operator T
 T^* - Hilbert space (hermitian) adjoint of Hilbert space operator T
 T_m - Fourier multiplier operator associated with multiplier m
 $T \otimes I_X$ - tensor extension of T

Constants and inequalities

$\alpha_{p,X}$ - Pisier contraction property constant
 $\alpha_{p,X}^\pm$ - upper and lower Pisier contraction property constant
 $\beta_{p,X}$ - UMD constant
 $\beta_{p,X}^{\mathbb{R}}$ - UMD constant with signs ± 1
 $\beta_{p,X}^\pm$ - upper and lower randomised UMD constant
 $c_{q,X}$ - cotype q constant
 $c_{q,X}^\gamma$ - Gaussian cotype q constant
 $\Delta_{p,X}$ - triangular contraction property constant
 $\tilde{h}_{p,X}$ - norm of the Hilbert transform on $L^p(\mathbb{R}; X)$
 $K_{p,X}$ - K -convexity constant
 $K_{p,X}^\gamma$ - Gaussian K -convexity constant
 $\kappa_{p,q}$ - Kahane–Khintchine constant
 $\kappa_{p,q}^{\mathbb{R}}$ - idem, for real Rademacher variables
 $\kappa_{p,q}^\gamma$ - idem, for Gaussian sums
 $\kappa_{p,q,X}$ - idem, for a fixed Banach space X
 $\tau_{p,X}$ - type p constant
 $\tau_{p,X}^\gamma$ - Gaussian type p constant
 $\varphi_{p,X}(\mathbb{R}^d)$ - norm of the Fourier transform $\mathcal{F} : L^p(\mathbb{R}^d; X) \rightarrow L^{p'}(\mathbb{R}^d; X)$.

Miscellaneous

\hookrightarrow - continuous embedding
 $\mathbf{1}_A$ - indicator function
 $a \lesssim b$ - $\exists C$ such that $a \leq Cb$
 $a \lesssim_{p,P} b$ - $\exists C$, depending on p and P , such that $a \leq Cb$
 C - generic constant
 \complement - complement
 $d(x, y)$ - distance
 f^* - maximal function
 \tilde{f} - reflected function
 \widehat{f} - Fourier transform
 \widetilde{f} - inverse Fourier transform
 $f * g$ - convolution
 \Im - imaginary part
 Mf - Hardy–Littlewood maximal function
 $p' = p/(p - 1)$ - conjugate exponent
 $p^* = \max\{p, p'\}$

\Re - real part

$s \wedge t = \min\{s, t\}$

$s \vee t = \max\{s, t\}$

x - generic element of X

x^* - generic element of X^*

$x \otimes y$ - elementary tensor

x^+ , x^- , $|x|$ - positive part, negative part, and modulus of x

Standing assumptions

Throughout this book, two conventions will be in force.

1. Unless stated otherwise, the scalar field \mathbb{K} can be real or complex. Results which do not explicitly specify the scalar field to be real or complex are true over both the real and complex scalars.
2. In the context of randomisation, a *Rademacher variable* is a uniformly distributed random variable taking values in the set $\{z \in \mathbb{K} : |z| = 1\}$. Such variables are denoted by the letter ε . Thus, whenever we work over \mathbb{R} it is understood that ε is a real Rademacher variable, i.e.,

$$\mathbb{P}(\varepsilon = 1) = \mathbb{P}(\varepsilon = -1) = \frac{1}{2},$$

and whenever we work over \mathbb{C} it is understood that ε is a complex Rademacher variable (also called a *Steinhaus variable*), i.e.,

$$\mathbb{P}(a < \arg(\varepsilon) < b) = \frac{1}{2\pi}(b - a).$$

Occasionally we need to use real Rademacher variables when working over the complex scalars. In those instances we will always denote these with the letter r . Similar conventions are in force with respect to Gaussian random variables: a *Gaussian random variable* is a standard normal real-valued variable when working over \mathbb{R} and a standard normal complex-valued variable when working over \mathbb{C} .

Random sums

One of the main themes in these volumes is the use of probabilistic techniques in general, and random sums in particular, in Banach space-valued Analysis. A first glimpse of their usefulness was already offered by the classical Theorem 2.1.9 of Paley, Marcinkiewicz and Zygmund on the extendability of bounded operators on $L^p(S)$ to bounded operators on $L^p(S; H)$, the proof of which involved estimates on Gaussian random sums. On the other hand, Rademacher random sums played a key role both in the formulation and in the proofs of the Littlewood–Paley theory in $L^p(\mathbb{R}^d; X)$ developed in Chapter 5.

In the chapter at hand, we will make a systematic investigation of the properties of the mentioned the two aforementioned species of random sums, Rademacher and Gaussian sums. The first three Sections 6.1, 6.2, and 6.3 are concerned with their basic relations and estimates in the context of finite sums, whereas Section 6.4 is devoted to two fundamental convergence results, the Itô–Nisio theorem and the Hoffmann–Jørgensen–Kwapień theorem, for infinite random series. In the final Section 6.5, we present Pisier’s theorem on the comparison of Rademacher sums and trigonometric sums. It will be applied in the further development of the Littlewood–Paley theory, to which we return in Chapter 8.

With one exception, the present chapter deals with general aspects of random sums that remain valid in arbitrary Banach spaces. The rich interplay between more sophisticated estimates for these sums on the one hand, and the properties of the underlying Banach spaces on the other hand, will be taken up in the following Chapter 7. The exception is the Hoffmann–Jørgensen–Kwapień theorem, which relates the convergence of X -valued random sums to the containment of c_0 as an isomorphic subspace in X . It will play an important role in Chapter 9, where we extend the present considerations of random sums over finite or countable sequences $x_n = f(n)$ in order to deal with certain ‘randomised norms’ of functions f on general measure spaces. This, in turn, provides a powerful tool for the study of the H^∞ -calculus in the last chapter.

6.1 Basic notions and estimates

We begin with a brief discussion of the notion of *random variable* in the Banach space-valued context. We refer the reader to Appendix E for an introduction to some standard notions of probability theory.

Let X be a (real or complex) Banach space.

Definition 6.1.1. *An X -valued random variable is an X -valued strongly measurable function ξ defined on some probability space $(\Omega, \mathcal{F}, \mathbb{P})$.*

The underlying probability space $(\Omega, \mathcal{F}, \mathbb{P})$ will always be considered given and fixed, and when several random variables are considered simultaneously we will assume them to be defined on the same probability space, unless the contrary is stated (and there are also cases when this is useful).

The notion of strong measurability has been studied in great detail in Chapter 1. We recall that a function is said to be *strongly measurable* if it is the pointwise limit of a sequence of simple functions. By the Pettis measurability theorem (Theorem 1.1.6) a function ξ is strongly measurable if and only if it is separably-valued and weakly measurable, where the latter means that the scalar-valued functions $\langle \xi, x^* \rangle$ are measurable in the usual sense for all functionals $x \in X^*$. Moreover, strongly measurable functions are measurable (Corollary 1.1.2), i.e., the pre-images of open sets are measurable, and in separable Banach spaces the notions of strong measurability and measurability coincide (Corollary 1.1.10). As a consequence of these facts, standard definitions and results for measurable random variables taking values in separable metric spaces, such as those collected in Appendix E, apply in the present setting.

Remark 6.1.2 (Strong measurability versus strong \mathbb{P} -measurability). A further subtlety concerns the distinction between strong measurability and strong μ -measurability (cf. Definitions 1.1.4 and 1.1.14). Recall that a function is said to be *strongly \mathbb{P} -measurable* if it is \mathbb{P} -almost everywhere (in contrast to everywhere) the pointwise limit of a sequence of simple functions; if we work over a general measure space it is furthermore required that the approximating simple functions be supported on sets of finite measure. If ξ is a strongly \mathbb{P} -measurable, then ξ can be redefined on a \mathbb{P} -null set to become a strongly measurable random variable $\tilde{\xi}$ (Proposition 1.1.16). We may then define

$$\mathbb{P}(\xi \in B) := \mathbb{P}(\tilde{\xi} \in B)$$

for any set B in $\mathcal{B}(X)$, the Borel σ -algebra of X . This definition is independent of the choice of the pointwise defined representative $\tilde{\xi}$ and allows one to treat strongly \mathbb{P} -measurable functions as random variables. As long as we are dealing with properties of random variables that only depend on their (joint) distributions, we may thus use the notions of ‘strongly measurable’ and ‘strongly \mathbb{P} -measurable’ interchangeably, and we will indeed do so. Only

when the risk of confusion arises we will be more precise in this respect, for instance when dealing with the σ -algebra generated by a random variable or a family of random variables.

In the same vein, an *integrable* random variable will always mean a random variable that is Bochner integrable with respect to \mathbb{P} .

The Bochner integral of an integrable X -valued random variable ξ is called its *mean (value) or expectation* and is denoted by $\mathbb{E}(\xi)$ or just $\mathbb{E}\xi$. Thus,

$$\mathbb{E}\xi := \int_{\Omega} \xi \, d\mathbb{P}.$$

The *distribution* of ξ is the Borel probability measure μ_{ξ} on X defined by

$$\mu_{\xi}(B) := \mathbb{P}(\xi \in B), \quad \xi \in \mathcal{B}(X).$$

As a consequence of the substitution rule (Theorem 1.2.6), the expectation of an integrable random variable is given in terms of its distribution by

$$\mathbb{E}\xi = \int_X x \, d\mu_{\xi}(x).$$

Simple criteria for random variables to have the same distribution can be given in terms of the so-called characteristic function, which is discussed in Section E.1.c.

A family of X -valued random variables $(\xi_i)_{i \in I}$ is said to be *independent* if for all choices of distinct indices $i_1, \dots, i_N \in I$ and all $B_1, \dots, B_N \in \mathcal{B}(X)$ we have

$$\mathbb{P}(\xi_{i_1} \in B_1, \dots, \xi_{i_N} \in B_N) = \prod_{n=1}^N \mathbb{P}(\xi_{i_n} \in B_n),$$

or equivalently (by Dynkin's lemma, Lemma A.1.3) the distribution of the X^N -valued random variable $(\xi_{i_1}, \dots, \xi_{i_N})$ equals the product of the distributions of the ξ_{i_n} . For further details the reader is referred to Section E.1.b.

The identity

$$\mathbb{E}(\xi_1 \xi_2) = \mathbb{E}\xi_1 \cdot \mathbb{E}\xi_2$$

for independent scalar-valued integrable random variables ξ_1 and ξ_2 admits the following extension to the vector-valued case. For a discussion of independence of random variables with values in a metric space we refer to Appendix E.

Proposition 6.1.3. *Let X_1, X_2, Y be Banach spaces and $\beta : X_1 \times X_2 \rightarrow Y$ be a bounded bilinear mapping. If the random variables ξ_1 and ξ_2 are independent and integrable, with values in X_1 and X_2 respectively, then $\beta(\xi_1, \xi_2)$ is integrable and*

$$\mathbb{E}\beta(\xi_1, \xi_2) = \beta(\mathbb{E}\xi_1, \mathbb{E}\xi_2).$$

Proof. The integrability of $\beta(\xi_1, \xi_2)$ follows from

$$\mathbb{E}\|\beta(\xi_1, \xi_2)\| \leq \|\beta\| \mathbb{E}(\|\xi_1\| \|\xi_2\|) = \|\beta\| \mathbb{E}\|\xi_1\| \mathbb{E}\|\xi_2\| < \infty,$$

where $\|\beta\| := \sup\{\|\beta(x_1, x_2)\| : \|x_1\|, \|x_2\| \leq 1\}$ is finite by assumption.

To prove the identity for the expectation we proceed as follows. Let $A_1 \in \sigma(\xi_1)$ and $A_2 \in \sigma(\xi_2)$ (we use the notation $\sigma(\xi)$ to denote the σ -algebra generated by ξ). Then, by bilinearity,

$$\begin{aligned} \mathbb{E}\beta(\mathbf{1}_{A_1} \otimes x_1, \mathbf{1}_{A_2} \otimes x_2) &= \mathbb{E}(\mathbf{1}_{A_1} \mathbf{1}_{A_2} \beta(x_1, x_2)) \\ &= \mathbb{E}\mathbf{1}_{A_1} \mathbb{E}\mathbf{1}_{A_2} \beta(x_1, x_2) \\ &= \beta(\mathbb{E}(\mathbf{1}_{A_1} \otimes x_1), \mathbb{E}(\mathbf{1}_{A_2} \otimes x_2)). \end{aligned}$$

Once again by bilinearity, this proves the identity $\mathbb{E}\beta(\phi_1, \phi_2) = \beta(\mathbb{E}\phi_1, \mathbb{E}\phi_2)$ for all simple $\phi_k : \Omega \rightarrow X_k$ that are $\sigma(\xi_k)$ -measurable, $k = 1, 2$. By dominated convergence, this implies the same identity for arbitrary $\phi_k \in L^1(\Omega, \sigma(\xi_k); X_k)$; in particular, this proves the identity for ξ_1 and ξ_2 . \square

It is evident how to extend this result to the multilinear case, and to the sesquilinear case when $\mathbb{K} = \mathbb{C}$. The prime examples of interest include duality and scalar multiplication

$$\begin{aligned} \beta(x, x^*) &:= \langle x, x^* \rangle & X_1 = X, X_2 = X^*, Y = \mathbb{K}, \\ \beta(\lambda, x) &:= \lambda x & X_1 = \mathbb{K}, X_2 = Y = X. \end{aligned}$$

In such cases, we will apply Proposition 6.1.3 casually, without an explicit reference to either the proposition or a particular “bilinear form”.

6.1.a Symmetric random variables and randomisation

A distinguished role in the subsequent developments is played by random variables with a simple additional property:

Definition 6.1.4 (Symmetric random variables). *An X -valued random variable is called:*

- (1) symmetric, if ξ and $\epsilon\xi$ are identically distributed for all $\epsilon \in \mathbb{K}$ with $|\epsilon| = 1$;
- (2) real-symmetric, if ξ and $-\xi$ are identically distributed.

Clearly, symmetry implies real-symmetry, and in real Banach spaces the two notions coincide. In complex Banach spaces a random variable ξ is symmetric if and only if ξ and $e^{i\theta}\xi$ are identically distributed for all $\theta \in [0, 2\pi]$. We will sometimes refer to the latter property as *complex-symmetry*.

Symmetric random variables have a useful monotonicity property with respect to taking L^p -norms:

Proposition 6.1.5. *Let ξ and η be X -valued random variables. If η is real-symmetric and independent of ξ , then for all $1 \leq p \leq \infty$ we have*

$$\|\xi\|_{L^p(\Omega; X)} \leq \|\xi + \eta\|_{L^p(\Omega; X)}.$$

Somewhat informal statements such as this one are to be interpreted in the obvious way; for instance, here we are saying that $\xi + \eta \in L^p(\Omega; X)$ implies $\xi \in L^p(\Omega; X)$ along with the stated inequality.

Proof. The real-symmetry of η and the independence of ξ and η imply that $\xi + \eta$ and $\xi - \eta$ are identically distributed, and therefore

$$\begin{aligned} (\mathbb{E}\|\xi\|^p)^{1/p} &= \frac{1}{2}(\mathbb{E}\|(\xi + \eta) + (\xi - \eta)\|^p)^{1/p} \\ &\leq \frac{1}{2}(\mathbb{E}\|\xi + \eta\|^p)^{1/p} + \frac{1}{2}(\mathbb{E}\|\xi - \eta\|^p)^{1/p} = (\mathbb{E}\|\xi + \eta\|^p)^{1/p}. \end{aligned}$$

Here we took $1 \leq p < \infty$; the modification needed for $p = \infty$ is obvious. \square

As a typical application, suppose $(\xi_n)_{n=1}^N$ is a sequence of independent real-symmetric scalar-valued random variables and $(x_n)_{n=1}^N$ is a sequence in X . Then, for all $I \subseteq \{1, \dots, N\}$,

$$\left\| \sum_{n \in I} \xi_n x_n \right\|_{L^p(\Omega; X)} \leq \left\| \sum_{n=1}^N \xi_n x_n \right\|_{L^p(\Omega; X)}.$$

By a limiting argument, a similar inequality holds for convergent random series. A more general inequality, the Kahane contraction principle, will be discussed in the next section.

Of special interest are Rademacher and Gaussian random variables.

Definition 6.1.6 (Rademacher variables and sequences). *A Rademacher variable is a random variable ε uniformly distributed over $\{z \in \mathbb{K} : |z| = 1\}$. A Rademacher sequence consists of independent Rademacher variables ε_n .*

In the real case, a Rademacher variable ε takes the values ± 1 with equal probability $\frac{1}{2}$, i.e.,

$$\mathbb{P}(\varepsilon = 1) = \mathbb{P}(\varepsilon = -1) = \frac{1}{2}.$$

In the complex case, a Rademacher variable is a random variable with uniform distribution on the unit circle in the complex plane. Classically, such variables are sometimes called *Steinhaus random variables*. If we wish to use real Rademachers in a complex setting, this will be explicitly mentioned and the notation r will be used instead of ε .

The notion of a Gaussian random variable is discussed at length in Appendix E.2, and we will not repeat it here. We only point out that this notion is adapted to the scalar field in the same way as the notion of symmetry

and that of a Rademacher variable. If we wish to use real Gaussian variables when working over the complex scalars, we will always mention this explicitly. In this situation we will use the notation g for real Gaussians and reserve the notation γ for complex Gaussians. Whereas Rademacher variables are intimately connected with unconditionality and provide the tool for randomisation techniques, the main virtue of Gaussians is their invariance under the orthogonal group. This is the basis of the principle of covariance domination, the consequences of which will be explored in later chapters.

Definition 6.1.7 (Gaussian sequences). *A Gaussian sequence consists of independent standard Gaussian variables γ_n .*

The reader should keep in mind that both the definition of symmetry and that of Rademacher and Gaussian variables depends on the choice of the underlying scalar field. Although this convention is perhaps not entirely standard in the Probability literature, it is analogous to the standard convention in Functional Analysis that a *linear* map is a *real-linear* map in the real case and a *complex-linear* map in the complex case. We wish to emphasise that this is not an accidental observation but a key point: our definition of symmetry is consistent with the scalar multiplication of the underlying Banach space X . The advantages of this approach will become clear along the way.

The Rademacher variables are often hiding in the background, even when their presence is not immediately obvious, thanks to the following basic lemma, which may be regarded as a toy model of the *randomisation* technique discussed below.

Lemma 6.1.8 (Polar decomposition). *Let ξ be a symmetric X -valued random variable, and ε an independent Rademacher variable. Then ξ and $\varepsilon\xi$ are identically distributed.*

If $X = \mathbb{K}$, they are also identically distributed with $\varepsilon|\xi|$.

Proof. Preserving the joint distributions, we may assume that the independent random variables are defined on different probability spaces Ω_ξ and Ω_ε . We denote the corresponding probabilities and expectations by obvious subscripts. Then

$$\mathbb{P}(\varepsilon\xi \in B) = \mathbb{E}\mathbf{1}_{\{\varepsilon\xi \in B\}} = \mathbb{E}_\varepsilon\mathbb{E}_\xi\mathbf{1}_{\{\varepsilon\xi \in B\}} \stackrel{(*)}{=} \mathbb{E}_\varepsilon\mathbb{E}_\xi\mathbf{1}_{\{\xi \in B\}} = \mathbb{P}(\xi \in B),$$

where the critical step (*) used the fact that, for each fixed $\omega \in \Omega_\varepsilon$, the random variables $\varepsilon(\omega)\xi$ and ξ on Ω_ξ have equal distribution by the assumed symmetry of ξ .

If $X = \mathbb{K}$ we can make a similar computation

$$\mathbb{P}(\varepsilon\xi \in B) = \mathbb{E}_\xi\mathbb{E}_\varepsilon\mathbf{1}_{\{\varepsilon\xi \in B\}} \stackrel{(*)}{=} \mathbb{E}_\xi\mathbb{E}_\varepsilon\mathbf{1}_{\{\varepsilon|\xi| \in B\}} = \mathbb{P}(\varepsilon|\xi| \in B).$$

In (*) we used the fact that, for each fixed $\omega \in \Omega_\xi$, the random variables $\xi(\omega)/|\xi(\omega)| \cdot \varepsilon$ and ε , and therefore also $\xi(\omega)\varepsilon$ and $|\xi(\omega)|\varepsilon$, have equal distribution by the assumed symmetry of ε . \square

Randomisation

We will now present an extremely useful result that permits one to change the signs of the coefficients in a sum of independent symmetric variables in a deterministic or random way. For its formulation we need a definition.

Definition 6.1.9. *Let I and J be index sets.*

- *Two families of random variables $(\xi_i)_{i \in I}$ and $(\eta_i)_{i \in I}$ are called identically distributed if for all indices $i_1, \dots, i_N \in I$ the random variables $(\xi_{i_1}, \dots, \xi_{i_N})$ and $(\eta_{i_1}, \dots, \eta_{i_N})$ are identically distributed.*
- *Two families of random variables $(\xi_i)_{i \in I}$ and $(\eta_j)_{j \in J}$ are called independent if for all indices $i_1, \dots, i_N \in I$ and $j_1, \dots, j_M \in J$ the random variables $(\xi_{i_1}, \dots, \xi_{i_N})$ and $(\eta_{j_1}, \dots, \eta_{j_M})$ are independent.*

By Dynkin's lemma (Lemma A.1.3), the random variables $(\xi_{i_1}, \dots, \xi_{i_N})$ and $(\eta_{i_1}, \dots, \eta_{i_N})$ are identically distributed if and only if

$$\mathbb{P}(\xi_{i_1} \in B_1, \dots, \xi_{i_N} \in B_N) = \mathbb{P}(\eta_{i_1} \in B_1, \dots, \eta_{i_N} \in B_N)$$

for all Borel sets B_1, \dots, B_N . In particular, two families of *independent* random variables are identically distributed if and only if for every $i \in I$ the random variables ξ_i and η_i are identically distributed.

Likewise, the random variables $(\xi_{i_1}, \dots, \xi_{i_N})$ and $(\eta_{j_1}, \dots, \eta_{j_M})$ are independent if and only if

$$\begin{aligned} \mathbb{P}(\xi_{i_1} \in B_1, \dots, \xi_{i_N} \in B_N, \eta_{j_1} \in C_1, \dots, \eta_{j_M} \in C_M) \\ = \mathbb{P}(\xi_{i_1} \in B_1, \dots, \xi_{i_N} \in B_N) \mathbb{P}(\eta_{j_1} \in C_1, \dots, \eta_{j_M} \in C_M) \end{aligned}$$

for all Borel sets B_1, \dots, B_N and C_1, \dots, C_M . It is not true, however, that two families of *independent* random variables $(\xi_i)_{i \in I}$ and $(\eta_i)_{i \in I}$ are independent if for all $i, i' \in I$ the random variables ξ_i and $\eta_{i'}$ are independent.

Example 6.1.10. Let ε_1 and ε_2 be independent Rademacher variables and let $\eta := \varepsilon_1 \varepsilon_2$. Then clearly $\{\varepsilon_1, \varepsilon_2\}$ and $\{\eta\}$ are not independent; however, η is independent of both ε_1 and ε_2 . In fact, assuming without loss of generality that ε_1 and ε_2 are defined on different probability spaces Ω_1, Ω_2 , we have

$$\begin{aligned} \mathbb{P}(\varepsilon_1 \in A, \eta \in B) &= \mathbb{E}_1 \mathbb{E}_2(\mathbf{1}_{\{\varepsilon_1 \in A\}} \mathbf{1}_{\{\varepsilon_1 \varepsilon_2 \in B\}}) = \mathbb{E}_1(\mathbf{1}_{\{\varepsilon_1 \in A\}} \mathbb{E}_2 \mathbf{1}_{\{\varepsilon_1 \varepsilon_2 \in B\}}) \\ &= \mathbb{E}_1(\mathbf{1}_{\{\varepsilon_1 \in A\}} \mathbb{E}_2 \mathbf{1}_{\{\varepsilon_2 \in B\}}) = \mathbb{E}_1(\mathbf{1}_{\{\varepsilon_1 \in A\}}) \mathbb{E}_2(\mathbf{1}_{\{\varepsilon_2 \in B\}}), \end{aligned}$$

where $\mathbb{E}_1(\mathbf{1}_{\{\varepsilon_1 \in A\}}) = \mathbb{P}(\varepsilon_1 \in A)$ and

$$\mathbb{E}_2(\mathbf{1}_{\{\varepsilon_2 \in B\}}) = \mathbb{E}_1 \mathbb{E}_2(\mathbf{1}_{\{\varepsilon_2 \in B\}}) = \mathbb{E}_1 \mathbb{E}_2(\mathbf{1}_{\{\varepsilon_1 \varepsilon_2 \in B\}}) = \mathbb{P}(\eta \in B).$$

Proposition 6.1.11 (Randomisation). *Let $(\xi_n)_{n \geq 1}$ be a sequence of independent and symmetric X -valued random variables, let $(\varepsilon_n)_{n \geq 1}$ be a sequence in $\{z \in \mathbb{K} : |z| = 1\}$, and let $(\varepsilon_n)_{n \geq 1}$ be a Rademacher sequence which is independent of $(\xi_n)_{n \geq 1}$.*

- (1) The sequences $(\xi_n)_{n \geq 1}$, $(\epsilon_n \xi_n)_{n \geq 1}$, and $(\varepsilon_n \xi_n)_{n \geq 1}$ are identically distributed.
- (2) If the random variables ξ_n are scalar-valued, then the sequences $(\xi_n)_{n \geq 1}$ and $(\varepsilon_n |\xi_n|)_{n \geq 1}$ are identically distributed.

The same result holds if one replaces $\{\text{symmetric, } \mathbb{K}, \text{Rademacher}\}$ by $\{\text{real-symmetric, } \mathbb{C}, \text{real Rademacher}\}$.

Proof. (1): By independence, we may assume that each ξ_n and ε_n is defined on a different probability space, say ξ_n on Ω_n and ε_n on Ω'_n . From this it is clear that the sequence $(\varepsilon_n \xi_n)_{n \geq 1}$ since the random variables are defined on the different probability spaces $\Omega_n \times \Omega'_n$.

Thus it suffices to show that for each fixed $n \geq 1$, the random variables ξ_n , $\epsilon_n \xi_n$, and $\varepsilon_n \xi_n$ are identically distributed. For ξ_n and $\epsilon_n \xi_n$ this is the definition of symmetry. For ξ_n and $\varepsilon_n \xi_n$, this is Lemma 6.1.8.

(2): As above, it suffices to prove that ξ_n and $\varepsilon_n |\xi_n|$ are identically distributed. This follows from Lemma 6.1.8. \square

A first application of these ideas is the following simple maximal estimate.

Proposition 6.1.12 (Lévy's inequality). *Let ξ_1, \dots, ξ_n be independent real-symmetric X -valued random variables, and put $S_k := \sum_{j=1}^k \xi_j$ for $k = 1, \dots, n$. Then for all $r \geq 0$ we have*

$$\mathbb{P}\left(\max_{1 \leq k \leq n} \|S_k\| > r\right) \leq 2\mathbb{P}(\|S_n\| > r).$$

Proof. Put

$$A := \left\{ \max_{1 \leq k \leq n} \|S_k\| > r \right\},$$

$$A_k := \left\{ \|S_1\| \leq r, \dots, \|S_{k-1}\| \leq r, \|S_k\| > r \right\}; \quad k = 1, \dots, n.$$

The sets A_1, \dots, A_n are disjoint and $\bigcup_{k=1}^n A_k = A$.

The identity $S_k = \frac{1}{2}(S_n + (2S_k - S_n))$ implies that

$$\{\|S_k\| > r\} \subseteq \{\|S_n\| > r\} \cup \{\|2S_k - S_n\| > r\}.$$

By Proposition 6.1.11, (ξ_1, \dots, ξ_n) and $(\xi_1, \dots, \xi_k, -\xi_{k+1}, \dots, -\xi_n)$ are identically distributed, which, in view of the identities

$$S_n = S_k + \xi_{k+1} + \dots + \xi_n, \quad 2S_k - S_n = S_k - \xi_{k+1} - \dots - \xi_n,$$

implies that $(\xi_1, \dots, \xi_k, S_n)$ and $(\xi_1, \dots, \xi_k, 2S_k - S_n)$ are identically distributed. Hence,

$$\begin{aligned} \mathbb{P}(A_k) &\leq \mathbb{P}(A_k \cap \{\|S_n\| > r\}) + \mathbb{P}(A_k \cap \{\|2S_k - S_n\| > r\}) \\ &= 2\mathbb{P}(A_k \cap \{\|S_n\| > r\}). \end{aligned}$$

Summing over k , we obtain

$$\mathbb{P}(A) = \sum_{k=1}^n \mathbb{P}(A_k) \leq 2 \sum_{k=1}^n \mathbb{P}(A_k \cap \{\|S_n\| > r\}) = 2\mathbb{P}(\|S_n\| > r).$$

□

6.1.b Kahane's contraction principle

One of the most useful tools for estimating random sums is the following contraction principle due to Kahane, which asserts that scalar sequences act as multipliers with respect to the L^p -norm. The randomisation technique gives us this immediate extension from a version already covered in Proposition 3.2.10.

Theorem 6.1.13 (Kahane's contraction principle). *Let $1 \leq p \leq \infty$ and let $(\xi_n)_{n=1}^N$ be a sequence of independent random variables in $L^p(\Omega; X)$.*

(i) *If all ξ_n are \mathbb{K} -symmetric, then for all sequences $(a_n)_{n=1}^N$ in \mathbb{K} we have*

$$\left\| \sum_{n=1}^N a_n \xi_n \right\|_{L^p(\Omega; X)} \leq \max_{1 \leq n \leq N} |a_n| \left\| \sum_{n=1}^N \xi_n \right\|_{L^p(\Omega; X)}.$$

(ii) *If all ξ_n are \mathbb{R} -symmetric, then for all sequences $(a_n)_{n=1}^N$ in \mathbb{C} we have*

$$\left\| \sum_{n=1}^N a_n \xi_n \right\|_{L^p(\Omega; X)} \leq \frac{\pi}{2} \max_{1 \leq n \leq N} |a_n| \left\| \sum_{n=1}^N \xi_n \right\|_{L^p(\Omega; X)}.$$

The constants in these inequalities are sharp.

Proof. The special case that $\xi_n = \varepsilon_n x_n$ in (i) or $\xi_n = r_n x_n$ in (ii) has already been treated in Proposition 3.2.10. We will use randomisation to reduce the general statement to this special case.

Indeed, letting $(\varepsilon_n)_{n=1}^N$ be an independent Rademacher sequence on another probability space Ω' , we have

$$\begin{aligned} \left\| \sum_{n=1}^N a_n \xi_n \right\|_{L^p(\Omega; X)} &= \left\| \sum_{n=1}^N a_n \varepsilon_n \xi_n \right\|_{L^p(\Omega; L^p(\Omega'; X))} \\ &\leq \max_{1 \leq n \leq N} |a_n| \left\| \sum_{n=1}^N \varepsilon_n \xi_n \right\|_{L^p(\Omega; L^p(\Omega'; X))} \\ &= \max_{1 \leq n \leq N} |a_n| \left\| \sum_{n=1}^N \xi_n \right\|_{L^p(\Omega; X)} \end{aligned}$$

in case (i), and (ii) is proved similarly with obvious modifications. Both equalities above are based on randomisation, and the inequality is the special case of the theorem proved in Proposition 3.2.10, with $\varepsilon_n x_n$ in place of ξ_n . The sharpness has already been observed in this special case.

While the above chain of identities and estimates above is meaningful for all $p \in [1, \infty]$, one can also derive the case $p = \infty$ simply as the limit $p \rightarrow \infty$ of finite exponents, using $\|f\|_{L^\infty(\Omega)} = \lim_{p \rightarrow \infty} \|f\|_{L^p(\Omega)}$. \square

Remark 6.1.14. The symmetry assumption may be dropped from one of the variables ξ_m , say ξ_1 , in Theorem 6.1.13. Namely, suppose that ξ_1, \dots, ξ_N are independent and ξ_2, \dots, ξ_N are \mathbb{K} -symmetric, and consider a random variable ε uniformly distributed over $\{z \in K : |z| = 1\}$ and independent of all ξ_1, \dots, ξ_N . Then $(\xi_1, \varepsilon \xi_2, \dots, \varepsilon \xi_N)$ is equidistributed with $(\xi_1, \xi_2, \dots, \xi_N)$, and

$$\left\| \sum_{n=1}^N a_n \xi_n \right\|_{L^p(\Omega; X)} = \left\| a_1 \xi_1 + \sum_{n=2}^N a_n \varepsilon \xi_n \right\|_{L^p(\Omega; X)} = \left\| a_1 \bar{\varepsilon} \xi_1 + \sum_{n=2}^N a_n \xi_n \right\|_{L^p(\Omega; X)},$$

where $\bar{\varepsilon} \xi_1$ is a \mathbb{K} -symmetric random variable. In particular, it follows that

$$\left\| a_1 \bar{\varepsilon} \xi_1 + \sum_{n=2}^N a_n \xi_n \right\|_{L^p(\Omega; X)} \leq \|a\|_\infty \left\| \sum_{n=1}^N \xi_n \right\|_{L^p(\Omega; X)}.$$

This formulation includes Proposition 6.1.5 as a special case.

6.1.c Norm comparison of different random sums

In this subsection we prove several basic L^p -norm comparisons between the different types of random sums discussed so far.

Rademacher sums versus other symmetric random sums

We begin with the comparison of Rademacher sums against random sums involving general symmetric random coefficients.

Proposition 6.1.15 (Comparison). *Let $1 \leq p \leq \infty$ and let $(\xi_n)_{n=1}^N$ be a sequence of independent symmetric random variables in L^p and let $(\varepsilon_n)_{n \geq 1}$ denote a Rademacher sequence. Then for all $x_1, \dots, x_N \in X$ we have*

$$\left\| \sum_{n=1}^N \varepsilon_n x_n \right\|_{L^p(\Omega; X)} \leq \max_{1 \leq n \leq N} \frac{1}{\mathbb{E}|\xi_n|} \left\| \sum_{n=1}^N \xi_n x_n \right\|_{L^p(\Omega; X)}.$$

Note that in the case ξ_n is real/complex symmetric, the Rademacher sequence in the above result should be real/complex as well.

Proof. We may assume that the sequences $(\xi_n)_{n=1}^N$ and $(\varepsilon_n)_{n=1}^N$ are defined on two separate probability spaces Ω_ξ and Ω_ε . Expectations will be denoted by \mathbb{E}_ξ and \mathbb{E}_ε respectively. We may also assume that $\mathbb{E}_\xi|\xi_n| > 0$, since otherwise there is nothing to prove.

Let $\tilde{\xi}_n := \xi_n/\mathbb{E}_\xi|\xi_n|$. By the Kahane contraction principle it suffices to prove the inequality

$$\mathbb{E}_\varepsilon \left\| \sum_{n=1}^N \varepsilon_n x_n \right\|^p \leq \mathbb{E}_\xi \left\| \sum_{n=1}^N \tilde{\xi}_n x_n \right\|^p.$$

By Proposition 6.1.11 the sequences $(\tilde{\xi}_n)_{n=1}^N$ and $(\varepsilon_n|\tilde{\xi}_n|)_{n=1}^N$ are identically distributed. Using this together with the fact that $\mathbb{E}_\xi|\tilde{\xi}_n| = 1$ and Jensen's inequality, we estimate, for $p \in [1, \infty)$.

$$\begin{aligned} \mathbb{E}_\varepsilon \left\| \sum_{n=1}^N \varepsilon_n x_n \right\|^p &= \mathbb{E}_\varepsilon \left\| \mathbb{E}_\xi \sum_{n=1}^N \varepsilon_n |\tilde{\xi}_n| x_n \right\|^p \\ &\leq \mathbb{E}_\varepsilon \mathbb{E}_\xi \left\| \sum_{n=1}^N \varepsilon_n |\tilde{\xi}_n| x_n \right\|^p = \mathbb{E}_\xi \left\| \sum_{n=1}^N \tilde{\xi}_n x_n \right\|^p. \end{aligned}$$

The case $p = \infty$ can be obtained as the limit $p \rightarrow \infty$ in the statement. \square

A converse estimate holds for *uniformly bounded* random variables:

Proposition 6.1.16. *Let $(\xi_n)_{n \geq 1}$ be a sequence of independent symmetric random variables in L^∞ . Then for all $x_1, \dots, x_N \in X$ and $1 \leq p \leq \infty$ we have*

$$\left\| \sum_{n=1}^N \xi_n x_n \right\|_{L^p(\Omega; X)} \leq \max_{1 \leq n \leq N} \|\xi_n\|_{L^\infty} \left\| \sum_{n=1}^N \varepsilon_n x_n \right\|_{L^p(\Omega; X)}.$$

Proof. By Proposition 6.1.11 and the contraction principle we have

$$\begin{aligned} \left\| \sum_{n=1}^N \xi_n x_n \right\|_{L^p(\Omega; X)}^p &= \mathbb{E}_\xi \mathbb{E}_\varepsilon \left\| \sum_{n=1}^N \varepsilon_n \xi_n x_n \right\|^p \\ &\leq \mathbb{E}_\xi \max_{1 \leq n \leq N} \|\xi_n\|^p \mathbb{E}_\varepsilon \left\| \sum_{n=1}^N \varepsilon_n x_n \right\|^p \\ &\leq \max_{1 \leq n \leq N} \|\xi_n\|_{L^\infty}^p \left\| \sum_{n=1}^N \varepsilon_n x_n \right\|_{L^p(\Omega; X)}^p \end{aligned}$$

if $p \in [1, \infty)$, and the case $p = \infty$ follows by taking the limit $p \rightarrow \infty$. \square

We now specialise to the comparison of Rademacher and Gaussian random sums. To this purpose, we recall the identities (cf. (E.2) and (E.4))

$$\mathbb{E}|\gamma| = \frac{1}{\sqrt{2\pi}} \int_{-\infty}^{\infty} |x|e^{-x^2/2} dx = \frac{2}{\sqrt{2\pi}} \int_0^{\infty} te^{-t^2/2} dt = \sqrt{2/\pi} \quad (6.1)$$

in the real case, and

$$\mathbb{E}|\gamma| = \frac{1}{\pi} \int_{\mathbb{C}} |z|e^{-|z|^2} dz = 2 \int_0^{\infty} r^2 e^{-r^2} dr = \frac{1}{2}\sqrt{\pi} \quad (6.2)$$

in the complex case.

Corollary 6.1.17. *If $(\varepsilon_n)_{n \geq 1}$ is a Rademacher sequence and $(\gamma_n)_{n \geq 1}$ is a Gaussian sequence, then for all $x_1, \dots, x_N \in X$ and $1 \leq p < \infty$,*

$$\left\| \sum_{n=1}^N \varepsilon_n x_n \right\|_{L^p(\Omega; X)} \leq \frac{1}{\mathbb{E}|\gamma|} \left\| \sum_{n=1}^N \gamma_n x_n \right\|_{L^p(\Omega; X)}, \quad (6.3)$$

with $\mathbb{E}|\gamma|$ as in (6.1) (in the real case) or (6.2) (in the complex case).

Note that Gaussian sums are *not* in the scope of Proposition 6.1.16 (because a Gaussian random variable is unbounded), and indeed the next example shows that the estimate reverse to (6.3) fails for $X = c_0$. As will be shown later (Corollary 7.2.10), for Banach spaces X with finite cotype a reverse estimate does hold.

Example 6.1.18. Let $(e_n)_{n=1}^N$ be the standard basis of ℓ_N^∞ . Then

$$\mathbb{E} \left\| \sum_{n=1}^N \varepsilon_n e_n \right\|_{\ell_N^\infty}^p = 1 \quad \text{and} \quad \mathbb{E} \left\| \sum_{n=1}^N \gamma_n e_n \right\|_{\ell_N^\infty}^p \geq \mathbb{E} \max_{1 \leq n \leq N} |\gamma_n|^p \geq \frac{(\log(N))^{p/2}}{5^{p/2}}$$

for any $p \in [1, \infty)$. Here the final estimate follows from (E.10). In particular, there does not exist any finite constant $C \geq 0$ such that

$$\left\| \sum_{n=1}^N \gamma_n x_n \right\|_{L^p(\Omega; c_0)} \leq C \left\| \sum_{n=1}^N \varepsilon_n x_n \right\|_{L^p(\Omega; c_0)}$$

holds for all $N \geq 1$.

Real-symmetric sums versus complex-symmetric sums

We now turn to the comparison of real and complex versions of our basic random sums. Propositions 6.1.19 and 6.1.21 show that it is always possible to translate estimates in terms of complex Rademachers or Gaussians into estimates for real Rademachers or Gaussians.

Proposition 6.1.19. *Let $(r_n)_{n \geq 1}$ and $(\varepsilon_n)_{n \geq 1}$ be real and complex Rademacher sequences, respectively, and let X be a complex Banach space. Then for all $x_1, \dots, x_N \in X$ and $1 \leq p \leq \infty$ we have*

$$\frac{2}{\pi} \left\| \sum_{n=1}^N r_n x_n \right\|_{L^p(\Omega; X)} \leq \left\| \sum_{n=1}^N \varepsilon_n x_n \right\|_{L^p(\Omega; X)} \leq \frac{\pi}{2} \left\| \sum_{n=1}^N r_n x_n \right\|_{L^p(\Omega; X)}.$$

Moreover, the constant $\frac{\pi}{2}$ in the second estimate is optimal.

Proof. We may assume that $(r_n)_{n \geq 1}$ and $(\varepsilon_n)_{n \geq 1}$ are defined on distinct probability spaces Ω and Ω' . For each fixed $\omega' \in \Omega'$, we have

$$\frac{2}{\pi} \left\| \sum_{n=1}^N r_n x_n \right\|_{L^p(\Omega; X)} \leq \left\| \sum_{n=1}^N r_n \varepsilon_n(\omega') x_n \right\|_{L^p(\Omega; X)} \leq \frac{\pi}{2} \left\| \sum_{n=1}^N r_n x_n \right\|_{L^p(\Omega; X)},$$

where the second estimate is an application of the contraction principle (Theorem 6.1.13(ii)) with $a_n = \varepsilon_n(\omega')$ and $\xi_n = r_n x_n$, and the first one is also seen as an application of the same result by taking $a_n = \bar{\varepsilon}_n(\omega)$ and $\xi_n = r_n \varepsilon_n(\omega) x_n$.

Taking the $L^p(\Omega')$ -norms and using the randomisation identity

$$\left\| \sum_{n=1}^N r_n \varepsilon_n x_n \right\|_{L^p(\Omega \times \Omega'; X)} = \left\| \sum_{n=1}^N \varepsilon_n x_n \right\|_{L^p(\Omega'; X)},$$

we obtain the claimed estimate.

We show that the estimate is optimal in the end-point case $p = \infty$. It suffices to consider $X = \mathbb{C}$. Assume the second estimate holds with constant C instead of $\frac{\pi}{2}$. Let $x_n = e^{2\pi i n/N}$. Then we have the following chain

$$1 = \frac{1}{N} \left\| \sum_{n=1}^N \varepsilon_n x_n \right\|_{L^\infty(\Omega)} \leq \frac{C}{N} \left\| \sum_{n=1}^N r_n x_n \right\|_{L^\infty(\Omega)} \rightarrow \frac{2C}{\pi},$$

where the first identity is verified in Lemma 6.1.20 below, and the final limit as $N \rightarrow \infty$ has been evaluated in the proof of Proposition 3.2.10. This shows that $C \geq \pi/2$. \square

The proof of sharpness above used the following simple result concerning the L^∞ -norms of Rademacher sums.

Lemma 6.1.20. *For all scalars a_1, \dots, a_N ,*

$$\left\| \sum_{n=1}^N a_n \varepsilon_n \right\|_{L^\infty(\Omega)} = \sum_{n=1}^N |a_n|.$$

Proof. Without loss of generality we can assume $a_n \neq 0$ for all $1 \leq n \leq N$. The inequality $\left\| \sum_{n=1}^N a_n \varepsilon_n \right\|_{L^\infty(\Omega)} \leq \sum_{n=1}^N |a_n|$ is trivial. To prove the opposite inequality we consider the real and complex case separately.

In the real case one has

$$\mathbb{P}\left(\left| \sum_{n=1}^N a_n \varepsilon_n \right| = \sum_{n=1}^N |a_n|\right) \geq \mathbb{P}\left(\bigcap_{n=1}^N \{\varepsilon_n = \text{sgn}(a_n)\}\right) = 2^{-N}.$$

From this the required inequality follows. In the complex case let $\alpha \in (0, \pi/2)$ be arbitrary. Then

$$\begin{aligned}
\mathbb{P}\left(\left|\sum_{n=1}^N a_n \varepsilon_n\right| \geq \cos(\alpha) \sum_{n=1}^N |a_n|\right) \\
&\geq \mathbb{P}\left(\Re \sum_{n=1}^N a_n \varepsilon_n \geq \cos(\alpha) \sum_{n=1}^N |a_n|\right) \\
&\geq \mathbb{P}\left(\bigcap_{n=1}^N \{|\arg(a_n \varepsilon_n)| \leq \alpha\}\right) = (\alpha/\pi)^N.
\end{aligned}$$

Therefore, $\|\sum_{n=1}^N a_n \varepsilon_n\|_{L^\infty(\Omega)} \geq \cos(\alpha) \sum_{n=1}^N |a_n|$. As $\alpha \in (0, \pi/2)$ was arbitrary, the result follows. \square

We have the following Gaussian analogue of Proposition 6.1.19.

Proposition 6.1.21. *Let $(g_n)_{n \geq 1}$ and $(\gamma_n)_{n \geq 1}$ be real and complex Gaussian sequences, respectively, and let X be a complex Banach space. Then for all $x_1, \dots, x_N \in X$ and $1 \leq p < \infty$ we have*

$$\frac{1}{\sqrt{2}} \left\| \sum_{n=1}^N g_n x_n \right\|_{L^p(\Omega; X)} \leq \left\| \sum_{n=1}^N \gamma_n x_n \right\|_{L^p(\Omega; X)} \leq \sqrt{2} \left\| \sum_{n=1}^N g_n x_n \right\|_{L^p(\Omega; X)}.$$

Moreover, the constant $\frac{1}{\sqrt{2}}$ in the first estimate is optimal.

Proof. On a possibly larger probability space let $(g'_n)_{n \geq 1}$ be a real Gaussian sequence which is independent of $(g_n)_{n \geq 1}$. By Proposition 6.1.5,

$$\left\| \sum_{n=1}^N g_n x_n \right\|_{L^p(\Omega; X)} \leq \left\| \sum_{n=1}^N (g_n + i g'_n) x_n \right\|_{L^p(\Omega; X)}.$$

The first inequality follows from this by noting that the random variables $g_n + i g'_n$ are independent complex Gaussians with variance 2. The second inequality follows by considering real and imaginary parts separately and noting that $\Re \gamma_n$ and $\Im \gamma_n$ are independent Gaussians with variance $\frac{1}{2}$.

The constant $\sqrt{2}$ on the left-hand side of the estimate is optimal already for $N = 1$. Indeed, from (E.2) and (E.4) we see that

$$\frac{\|g\|_p}{\|\gamma\|_p} = \frac{\sqrt{2} \Gamma((p+1)/2)}{\pi^{1/(2p)} \Gamma(p/2 + 1)}.$$

Letting $p \rightarrow \infty$, the latter tends to $\sqrt{2}$ by elementary arguments. \square

Remark 6.1.22. As a consequence of the optimality on the left-hand side in Proposition 6.1.21, a central limit theorem argument (see Proposition 6.2.5 below) shows that the constant $2/\pi$ in Proposition 6.1.19 cannot be replaced by a constant larger than $1/\sqrt{2}$.

6.1.d Covariance domination for Gaussian sums

We continue with a very useful comparison principle for Gaussian random sums. In view of later applications we provide two versions, both of which hold for real and complex Banach spaces, provided we keep in mind the convention that Gaussian random variables are to be understood as real (complex) when we work over the real (complex) scalars.

Proposition 6.1.23. *Let $p \in [1, \infty)$. For all $m \times n$ matrices $A = (a_{ij})_{i,j=1}^{m,n}$ with entries in \mathbb{K} and all finite sequences $(x_j)_{j=1}^n$ in X ,*

$$\left\| \sum_{i=1}^m \gamma_i \sum_{j=1}^n a_{ij} x_j \right\|_{L^p(\Omega; X)} \leq \|A\| \left\| \sum_{j=1}^n \gamma_j x_j \right\|_{L^p(\Omega; X)}.$$

For the proof of Proposition 6.1.23 we need an elementary identity for matrices. Since we have reserved the symbol $T^* \in \mathcal{L}(X_2^*, X_1^*)$ for the Banach adjoint of an operator $T \in \mathcal{L}(X_1, X_2)$, we denote by $T^* \in \mathcal{L}(H_2, H_1)$ the Hilbert space (hermitian) adjoint of a Hilbert space operator $T \in \mathcal{L}(H_1, H_2)$.

Lemma 6.1.24. *For every square matrix T with $\|T\| \leq 1$ we have*

$$T(I - T^*T)^{1/2} = (I - TT^*)^{1/2}T. \quad (6.4)$$

Proof. Observe that the power series $(1 - z)^{1/2} = \sum_{n=0}^{\infty} \binom{n}{\frac{1}{2}} (-z)^n$ converges absolutely in the closed disk $|z| \leq 1$, and hence

$$(I - S)^{1/2} = \sum_{n=0}^{\infty} \binom{n}{\frac{1}{2}} (-1)^n S^n$$

for both self-adjoint matrices $S \in \{T^*T, TT^*\}$ of norm $\|S\| \leq 1$. Since clearly $T(T^*T)^n = (TT^*)^n T$ for every $n \in \mathbb{N}$, the result follows. \square

Proof of Proposition 6.1.23. We may assume that $\|A\| = 1$. By adding zero terms to the matrix $A = (a_{ij})_{i,j=1}^{m,n}$, we may also assume that $m = n$. Let B be the $2n \times 2n$ -matrix given by

$$B = \begin{pmatrix} A & (I - AA^*)^{1/2} \\ (I - A^*A)^{1/2} & -A^* \end{pmatrix}.$$

From (6.4) we deduce that $B^*B = I$. Writing $B = (b_{ij})_{i,j=1}^{2n}$ we have $a_{ij} = b_{ij}$ for $1 \leq i, j \leq n$. By Proposition 6.1.5,

$$\mathbb{E} \left\| \sum_{i=1}^n \gamma_i \sum_{j=1}^n a_{ij} x_j \right\|^p \leq \mathbb{E} \left\| \sum_{i=1}^{2n} \gamma_i \sum_{j=1}^n b_{ij} x_j \right\|^p = \mathbb{E} \left\| \sum_{j=1}^n G_j x_j \right\|^p,$$

where $G_j = \sum_{i=1}^{2m} \gamma_i b_{ij}$, for $1 \leq j \leq n$. The result now follows from the fact that $(G_j)_{j=1}^n$ is a Gaussian sequence by Proposition E.2.12: joint Gaussianity is evident, and uncorrelatedness follows from

$$\mathbb{E}(\bar{G}_k G_\ell) = \sum_{i=1}^{2m} \sum_{j=1}^{2m} \mathbb{E}(\bar{\gamma}_i \gamma_j) \bar{b}_{ik} b_{j\ell} = \sum_{i=1}^{2m} \bar{b}_{ik} b_{i\ell} = (B^* B)_{k\ell} = \delta_{k\ell}.$$

□

Theorem 6.1.25 (Covariance domination - I). *Let $(\gamma_k)_{k \geq 1}$ be a Gaussian sequence and let x_1, \dots, x_M and y_1, \dots, y_N be elements of X satisfying*

$$\sum_{m=1}^M |\langle x_m, x^* \rangle|^2 \leq \sum_{n=1}^N |\langle y_n, x^* \rangle|^2, \quad x^* \in X^*.$$

Then, for all $1 \leq p < \infty$,

$$\mathbb{E} \left\| \sum_{m=1}^M \gamma_m x_m \right\|^p \leq \mathbb{E} \left\| \sum_{n=1}^N \gamma_n y_n \right\|^p.$$

Proof. Consider the subspace $V := \{(\langle y_n, x^* \rangle)_{n=1}^N : x^* \in X^*\} \subseteq \ell_N^2$. By assumption, the linear operator

$$A : V \rightarrow \ell_M^2 : (\langle y_n, x^* \rangle)_{n=1}^N \rightarrow (\langle x_m, x^* \rangle)_{m=1}^M$$

is well defined and has norm $\|A\| \leq 1$. Thus it extends (by composing with the orthogonal projection of ℓ_N^2 onto V) to a linear operator $A : \ell_N^2 \rightarrow \ell_M^2$ of the same norm. Such an operator is given by a matrix $(a_{mn})_{m,n=1}^{M,N}$, hence $\langle x_m, x^* \rangle = \sum_{n=1}^N a_{mn} \langle y_n, x^* \rangle$ for all $m = 1, \dots, M$ and $x^* \in X^*$, and thus $x_m = \sum_{n=1}^N a_{mn} y_n$ for all $m = 1, \dots, M$. Therefore

$$\left\| \sum_{m=1}^M \gamma_m x_m \right\|_{L^p(\Omega; X)} = \left\| \sum_{m=1}^M \gamma_m \sum_{n=1}^N a_{mn} y_n \right\|_{L^p(\Omega; X)} \leq \left\| \sum_{n=1}^N \gamma_n y_n \right\|_{L^p(\Omega; X)}$$

by Proposition 6.1.23. □

Corollary 6.1.26 (Covariance domination - II). *Let $(\gamma_k)_{k \geq 1}$ be a Gaussian sequence. Let x_1, \dots, x_M and y_1, \dots, y_N be elements of a complex Banach space X satisfying*

$$\sum_{m=1}^M (\Re \langle x_m, x^* \rangle)^2 \leq \sum_{n=1}^N (\Re \langle y_n, x^* \rangle)^2, \quad x^* \in X^*.$$

Then, for all $1 \leq p < \infty$,

$$\mathbb{E} \left\| \sum_{m=1}^M \gamma_m x_m \right\|^p \leq \mathbb{E} \left\| \sum_{n=1}^N \gamma_n y_n \right\|^p.$$

Proof. Applying the assumptions to ix^* we also obtain

$$\sum_{m=1}^M (\mathfrak{S}\langle x_m, x^* \rangle)^2 \leq \sum_{n=1}^N (\mathfrak{S}\langle y_n, x^* \rangle)^2, \quad x^* \in X^*.$$

Adding these inequalities gives the assumption of Theorem 6.1.25. \square

Note that we could also derive Theorem 6.1.25 from Corollary 6.1.26 by an application of Lemma E.1.15.

6.2 Comparison of different L^p -norms

In this section we study another norm comparison phenomenon for random sums, namely, the comparability of different L^p -norms of a fixed random sum. A prime example of this phenomenon is the Kahane–Khintchine inequality for Rademacher sums,

$$\left\| \sum_{n=1}^N \varepsilon_n x_n \right\|_{L^q(\Omega; X)} \leq \kappa_{q,p} \left\| \sum_{n=1}^N \varepsilon_n x_n \right\|_{L^p(\Omega; X)} \quad (6.5)$$

for all $p, q \in (0, \infty)$. (The case of actual interest is of course $0 < p < q < \infty$, since in the complementary range the result is immediate with constant 1 by Hölder’s inequality.)

The above inequality was already given in Theorem 3.2.23, where it was derived as a corollary of a John–Nirenberg inequality for martingales. In this section, we give a complete alternative proof from a different point of view of independent interest: so-called hypercontractivity of the discrete heat semi-group. This leads to the asymptotically optimal (for large exponents) bound of the constant, $\kappa_{q,p} \leq \sqrt{\frac{q-1}{p-1}}$ in the case we work over the real scalar field (and consequently use real Rademacher variables) and $\kappa_{q,p} \leq \frac{\pi^2}{4} \sqrt{\frac{q-1}{p-1}}$ in case we work over the complex field (and use complex Rademachers), and thereby to exponential square-integrability estimates as a substitute of the (false) L^∞ bound at the end-point $q = \infty$.

The Gaussian version of the Kahane–Khintchine inequality holds as well but, in contrast to some estimates in the previous section, it does not seem to follow from a simple randomisation argument. Instead, a different approach via the central limit theorem will be used. This has independent interest as another route from results for Rademacher sums to their Gaussian counterparts.

Notation. We remind the reader that of the convention, in force throughout these volumes, that Rademacher variables are understood to be real (resp. complex) when we work over the real (resp. complex) scalar field. Accordingly, the numerical value of the Kahane–Khintchine constant $\kappa_{q,p}$ depends

on the choice of the scalar field. In certain situations one wishes to consider real Rademacher variables even when the underlying scalar field is complex. To anticipate on such situations we introduce the notation $\kappa_{q,p}^{\mathbb{R}}$ for the least constant κ in the inequality

$$\left\| \sum_{n=1}^N r_n x_n \right\|_{L^q(\Omega; X)} \leq \kappa \left\| \sum_{n=1}^N r_n x_n \right\|_{L^p(\Omega; X)}$$

with real Rademacher variables r_n , regardless the choice of the scalar field. For reasons of notational symmetry we also introduce the notation $\kappa_{q,p}^{\mathbb{C}}$ for the best constant for the inequality with complex Rademacher variables ε_n ; of course this definition only makes sense when the scalar field is complex.

If a fixed Banach space X is given, we denote by $\kappa_{q,p,X}$ the best constant in the inequality (6.5) with the choice of x_n limited to X ; as in the general Kahane–Khintchine inequality the Rademacher variables are understood to be real or complex depending on whether X is a real or complex Banach space. If we want to insist on the use of real (resp. complex) Rademacher variables we write $\kappa_{q,p,X}^{\mathbb{R}}$ (resp. $\kappa_{q,p,X}^{\mathbb{C}}$). With this notation the equality

$$\kappa_{q,p;X_{\mathbb{R}}} = \kappa_{q,p,X}^{\mathbb{R}}$$

is evident; recall that $X_{\mathbb{R}}$ is the real Banach space obtained by restricting the scalar multiplication in X to the reals.

In all this notation, a superscript ‘ γ ’ will be added to indicate that (real) (complex) Rademacher variables have been replaced by (real) (complex) Gaussian variables.

6.2.a The discrete heat semigroup and hypercontractivity

Consider the two-point space $D = \{-1, 1\}$ with the uniform probability distribution $\mu(\pm 1) = \frac{1}{2}$. The two-dimensional space of functions on this space has a basis consisting of $\mathbf{1}$ (the constant function) and r (a canonical Rademacher function defined by $r(\pm 1) = \pm 1$).

The space $D^N = \{-1, 1\}^N$ is sometimes called the discrete (hyper)cube. If r_n is the canonical Rademacher function defined on the n th component of D^N , by induction one checks that a basis of functions on D^N is given by the *Walsh functions*

$$w_\alpha := \prod_{n \in \alpha} r_n, \quad \alpha \subseteq \{1, \dots, N\},$$

where the empty product is defined as $\mathbf{1}$, as usual. It is immediate that these functions are orthonormal in $L^2(D^N)$, where D^N is equipped with the product measure. Thus any function $f : D^N \rightarrow X$ can be written as

$$f = \sum_{\alpha \subseteq \{1, \dots, N\}} w_\alpha x_\alpha, \quad x_\alpha = \mathbb{E}(w_\alpha f).$$

The *discrete heat semigroup* is defined as

$$T(t)f = \sum_{\alpha \subseteq \{1, \dots, N\}} e^{-t\#\alpha} w_\alpha x_\alpha = \sum_{\alpha \subseteq \{1, \dots, N\}} \left(\prod_{n \in \alpha} e^{-t r_n} \right) x_\alpha \quad (6.6)$$

where $\#\alpha$ is the number of elements of the set α . From the equality on the right it is immediate that

$$T(t) = \prod_{n=1}^N T_n(t), \quad (6.7)$$

where

$$T_n(t)(x + r_n y) = x + e^{-t} r_n y, \quad x, y \in X,$$

is the one-dimensional discrete heat semigroup acting on the n th coordinate. Thanks to the product formula, non-trivial properties of $T(t)$ on D^N can be deduced from two-point inequalities on the space $D = \{-1, 1\}$. Here is a simple example.

Lemma 6.2.1. *The operators $T(t)$, $t \geq 0$, are positive on $L^p(D^N)$ and contractive on $L^p(D^N; X)$ for all $p \in [1, \infty]$ and all Banach spaces X .*

Proof. For $N = 1$, the orthogonal projections to $\mathbf{1}$ and r are given by \mathbb{E} and $I - \mathbb{E}$. Thus, for $f = x + ry$ with $x, y \in X$, we see that

$$T(t)f = x + e^{-t} ry = \mathbb{E}f + e^{-t}(I - \mathbb{E})f = e^{-t}f + (1 - e^{-t})\mathbb{E}f \quad (6.8)$$

is a convex combination of the positive contractions I and \mathbb{E} . The case of general $N \geq 1$ follows from (6.7). \square

The main result of this subsection is the following strengthening known as *hypercontractivity* ('more than contractivity'). That is, as soon as $t > 0$, the operator $T(t)$ is contractive not only from L^p into itself, but into a 'better' space $L^q \subseteq L^p$ with $q > p$. (Of course, these spaces coincide as sets on the finite measure space D^N , but L^q has a stronger norm.)

Theorem 6.2.2 (Hypercontractivity of the discrete heat semigroup). *Let X be a Banach space and $1 < p \leq q < \infty$. Let $(T(t))_{t \geq 0}$ be the discrete heat semigroup defined in (6.6). Then*

$$\|T(t)\|_{L^p(D^N; X) \rightarrow L^q(D^N; X)} \leq 1$$

if and only if

$$e^{-t} \leq \sqrt{\frac{p-1}{q-1}}.$$

As in the simple Lemma 6.2.1, the core of the theorem is a two-point inequality.

Lemma 6.2.3 (Bonami's inequality). *Let r be a real Rademacher random variable and let $1 < p < q < \infty$. Then for every real number $\theta \geq 0$,*

$$\|x + \theta ry\|_{L^q(\Omega; X)} \leq \|x + ry\|_{L^p(\Omega; X)} \quad \text{for all } x, y \in X$$

if and only if

$$\theta \leq \sqrt{\frac{p-1}{q-1}}.$$

Proof. Note that the lemma is simply a restatement, with $\theta = e^{-t}$, of the fact that Theorem 6.2.2 holds for $N = 1$. Since $T(t)$ is a positive operator, it suffices (by Theorem 2.1.3) to consider $X = \mathbb{R}$. This reduction is also immediate from (6.8), which implies that $\|T(t)f\| \leq T(t)(\|f\|)$.

Case $1 < p < q \leq 2$: The result is clear for $x = 0$. If $x \neq 0$, then by homogeneity we only need to consider $x = 1$.

First assume that $|y| \leq 1$. Using the binomial series and the inequality $(1+z)^a \leq 1+az$ for all $z \geq 0$ and $0 < a < 1$, we estimate

$$\begin{aligned} \left(\frac{|1+\theta y|^q}{2} + \frac{|1-\theta y|^q}{2}\right)^{p/q} &= \left(1 + \sum_{n \geq 1} \binom{q}{2n} \theta^{2n} y^{2n}\right)^{p/q} \\ &\leq 1 + \frac{p}{q} \sum_{n \geq 1} \binom{q}{2n} \theta^{2n} y^{2n} \leq 1 + \sum_{n \geq 1} \binom{p}{2n} y^{2n} = \frac{|1+y|^p}{2} + \frac{|1-y|^p}{2}, \end{aligned}$$

where we used that $\frac{p}{q} \binom{q}{2n} \theta^{2n} \leq \binom{p}{2n}$. Indeed, the latter follows from

$$\begin{aligned} \frac{p}{q} \binom{q}{2n} \theta^{2n} &\leq \frac{p(p-1)(2-q)(3-q) \cdots (2n-1-q)}{(2n)!} \frac{(p-1)^{n-1}}{(q-1)^{n-1}} \\ &\leq \frac{p(p-1)(2-p)(3-p) \cdots (2n-1-p)}{(2n)!} = \binom{p}{2n}, \end{aligned}$$

where we used that $1 < p < q \leq 2$ implies $0 \leq (k-q)/\sqrt{q-1} \leq (k-p)/\sqrt{p-1}$ for all $k \geq 2$.

Next assume that $|y| > 1$. If $0 \leq a, b \leq 1$, then $1+ab-a-b = (1-a)(1-b) \geq 0$, so $a+b \leq 1+ab$. Hence, $|1 \pm \theta y| = |y||y^{-1} \pm \theta| \leq |y|(1 \pm \theta y^{-1})$. Therefore, from the above applied to y^{-1} we obtain that

$$\begin{aligned} \left(\frac{|1+\theta y|^q}{2} + \frac{|1-\theta y|^q}{2}\right)^{1/q} &\leq |y| \left(\frac{|1+\theta y^{-1}|^q}{2} + \frac{|1-\theta y^{-1}|^q}{2}\right)^{1/q} \\ &\leq |y| \left(\frac{|1+y^{-1}|^p}{2} + \frac{|1-y^{-1}|^p}{2}\right)^{1/p} \\ &= \left(\frac{|1+y|^p}{2} + \frac{|1-y|^p}{2}\right)^{1/p}. \end{aligned}$$

This completes the proof for $1 < p < q \leq 2$. In particular, we have shown that the operator $T(t) : L^p(D) \rightarrow L^q(D)$ is a contraction for $e^{-t} \leq \sqrt{\frac{p-1}{q-1}}$.

Case 2 $2 \leq p < q < \infty$: We use a duality argument. Indeed, $T(t)$ is formally self-adjoint, and the conjugate exponents satisfy $1 < q' < p' \leq 2$ and $\frac{q'-1}{p'-1} = \frac{p-1}{q-1}$ so that $\|T(t)\|_{L^p(D) \rightarrow L^q(D)} = \|T(t)\|_{L^{q'}(D) \rightarrow L^{p'}(D)} \leq 1$ for $e^{-t} \leq \sqrt{\frac{q'-1}{p'-1}} = \sqrt{\frac{p-1}{q-1}}$ by the previous case.

Case 1 $1 < p < 2 < q < \infty$: The result follows by combining the previous two cases. Indeed, applying the cases already proved to the pairs $(q, 2)$ and $(2, p)$ and using $\frac{p-1}{q-1} = \frac{p-1}{2-1} \frac{2-1}{q-1}$, we can split $t = t_1 + t_2$ so that $e^{-t_1} \leq \sqrt{\frac{1}{q-2}}$ and $e^{-t_2} \leq \sqrt{p-1}$. Then

$$\|T(t)\|_{L^p \rightarrow L^q} = \|T(t_1)T(t_2)\|_{L^p \rightarrow L^q} \leq \|T(t_1)\|_{L^2 \rightarrow L^q} \|T(t_2)\|_{L^p \rightarrow L^2} \leq 1.$$

Necessity of $\theta \leq \sqrt{\frac{p-1}{q-1}}$: To prove the ‘‘if’’ part note that the second order Taylor polynomials for $\phi(y) := \|1 + \theta ry\|_q^q$ and $\psi(y) := \|x + ry\|_p^q$ satisfy

$$\phi(y) = 1 + q(q-1)\theta^2 y^2 + O(y^3) \quad \text{and} \quad \psi(y) = 1 + q(p-1)\theta^2 y^2 + O(y^3)$$

Therefore, Lemma 6.2.3 implies $0 \leq \lim_{y \rightarrow 0} (\psi(y) - \phi(y))/y^2 = q(p-1) - q(q-1)\theta^2$, and hence $\theta^2 \leq (p-1)/(q-1)$. \square

Proof of Theorem 6.2.2. We use induction on N . The case $N = 1$ is already contained in Lemma 6.2.3. Suppose that the theorem is true for $N - 1$. Then, writing $D^N = D^{N-1} \times D_N$ (where D_N is simply the N th copy of D in the product) and accordingly $T(t) = T^{N-1}(t)T_N(t)$, where T^{N-1} is the discrete heat semigroup on D^{N-1} and T_N on D_N , we have

$$\begin{aligned} \|T(t)f\|_{L^q(D^N; X)} &= \|T_N(t)T^{N-1}(t)f\|_{L^q(D_N; L^q(D^{N-1}; X))} \\ &\leq \|T^{N-1}(t)f\|_{L^p(D_N; L^q(D^{N-1}; X))} \\ &\leq \|f\|_{L^p(D_N; L^p(D^{N-1}; X))} = \|f\|_{L^p(D^N; X)}, \end{aligned}$$

where the two inequalities were applications of Lemma 6.2.3 (with range $L^q(D^{N-1}; X)$ in place of X) and the induction hypothesis (pointwise on D_N). \square

6.2.b Kahane–Khintchine inequalities

As an immediate consequence of the hypercontractivity estimates, we obtain the following:

Theorem 6.2.4 (Kahane–Khintchine inequality, Rademacher sums).

Let $(\varepsilon_n)_{n \geq 1}$ be a Rademacher sequence. Then for all $0 < p < q < \infty$ and all sequences $(x_n)_{n=1}^N$ in any Banach space X , we have

$$\left\| \sum_{n=1}^N \varepsilon_n x_n \right\|_{L^q(\Omega; X)} \leq \kappa_{q,p} \left\| \sum_{n=1}^N \varepsilon_n x_n \right\|_{L^p(\Omega; X)}. \quad (6.9)$$

For $1 < p < q < \infty$, in the real and complex case one has, respectively,

$$\kappa_{q,p}^{\mathbb{R}} \leq \sqrt{\frac{q-1}{p-1}} \quad \text{and} \quad \kappa_{q,p}^{\mathbb{C}} \leq \frac{\pi^2}{4} \sqrt{\frac{q-1}{p-1}}.$$

In Theorem 6.6.5 in the Notes we indicate the sharper bound $\kappa_{q,p}^{\mathbb{C}} \leq \sqrt{q/p}$ in the complex case.

Proof. By Proposition 6.1.19 it suffices to prove the estimate for a real Rademacher sequence $(r_n)_{n \geq 1}$. Let $f := \sum_{n=1}^N r_n x_n$ and note that all its L^p -norms are finite. If $1 < p < q < \infty$ the result follows from Theorem 6.2.2 by observing that $T(t)f = e^{-t}f$ and choosing $t \geq 0$ such that $e^{-t} = \sqrt{\frac{p-1}{q-1}}$.

If $0 < p \leq 1 < q < \infty$, we pick $r \in (q, \infty)$ and write $1/q = \theta/p + (1-\theta)/r$ with $\theta \in (0, 1)$. Then

$$\|f\|_q \leq \|f\|_p^\theta \|f\|_r^{1-\theta} \leq \|f\|_p^\theta (\kappa_{r,q} \|f\|_q)^{1-\theta},$$

and therefore $\|f\|_q \leq \kappa_{r,q}^{(1-\theta)/\theta} \|f\|_p$. It follows that $\kappa_{q,p} \leq \kappa_{r,q}^{(1-\theta)/\theta} < \infty$ by the previous case.

If $0 < p < q < 1$, we can pick any $r \in (1, \infty)$ and observe that $\|f\|_q \leq \|f\|_r \leq \kappa_{r,p} \|f\|_p$, so that $\kappa_{q,p} \leq \kappa_{r,p} < \infty$ by the previous case. \square

In the scalar case, (6.9) reduces to the classical Khintchine's inequality:

$$\kappa_{p,2}^{-1} \left\| \sum_{n=1}^N c_n \varepsilon_n \right\|_{L^p} \leq \left\| \sum_{n=1}^N c_n \varepsilon_n \right\|_{L^2} = \left(\sum_{n=1}^N |c_n|^2 \right)^{1/2} \leq \kappa_{2,p} \left\| \sum_{n=1}^N c_n \varepsilon_n \right\|_{L^p}, \quad (6.10)$$

for all $p \in (0, \infty)$, where the equality is immediate by orthogonality.

In contrast to (6.10), recall from Lemma 6.1.20 that

$$\left\| \sum_{n=1}^N c_n \varepsilon_n \right\|_{L^\infty} = \sum_{n=1}^N |c_n|.$$

Since the ℓ^1 and ℓ^2 -norms are not comparable, the Kahane–Khintchine inequalities cannot be extended to $q = \infty$.

Gaussian case

The Gaussian version of Theorem 6.2.4 does not seem to be available via a simple randomisation argument, and we will instead introduce another important tool allowing the passage from Rademacher variables to Gaussian variables. This is based on an application of the following consequence of the central limit theorem (Theorems E.2.15 and E.2.16).

Proposition 6.2.5. *Let $(\varepsilon_m^1)_{m \geq 1}, \dots, (\varepsilon_m^N)_{m \geq 1}$ be independent Rademacher sequences and define*

$$\rho_k^n := \frac{1}{\sqrt{k}} \sum_{m=1}^k \varepsilon_m^n, \quad k \geq 1, \quad n = 1, \dots, N.$$

Let $\gamma^1, \dots, \gamma^N$ be independent standard Gaussian variables. Let $(x_n)_{n=1}^N$ be a sequence in X . Then, for all $0 < p < \infty$,

$$\lim_{k \rightarrow \infty} \left\| \sum_{n=1}^N \rho_k^n x_n \right\|_{L^p(\Omega; X)} = \left\| \sum_{n=1}^N \gamma_n x_n \right\|_{L^p(\Omega; X)}.$$

Proof. Defining $\varepsilon_m : \Omega \rightarrow \mathbb{K}^N$, $\rho_k : \Omega \rightarrow \mathbb{K}^N$, and $\gamma : \Omega \rightarrow \mathbb{K}^N$ in the obvious way, by the central limit theorem (see Theorems E.2.15 and E.2.16 for the real and complex case respectively) we have $\lim_{k \rightarrow \infty} \rho_k^1 = \gamma$ in distribution. Let

$$\xi_k := \left\| \sum_{n=1}^N \rho_k^n x_n \right\|, \quad \xi := \left\| \sum_{n=1}^N \gamma_n x_n \right\|.$$

By the continuity of the mapping $f : \mathbb{R}^n \rightarrow [0, \infty)$ given by

$$f(a_1, \dots, a_n) = \left\| \sum_{n=1}^N a_n x_n \right\|,$$

this implies that $\xi_k \rightarrow \xi$ in distribution.

Now let $0 < p < q < \infty$ be given. By Khintchine's inequality (6.9), $\|\rho_k^n\|_{L^q} \leq \kappa_{q,2}$, where $\kappa_{q,2} = 1$ if $0 < q \leq 2$. Therefore, by the triangle inequality,

$$\|\xi_k\|_{L^q} \leq \sum_{n=1}^N \|\rho_k^n\|_{L^q} \|x_n\| \leq \kappa_{q,2} \sum_{n=1}^N \|x_n\|.$$

By Example A.3.2, the family $\{|\xi_k|^p : k \geq 1\}$ is uniformly integrable and therefore Proposition E.1.7 implies that $\lim_{k \rightarrow \infty} \|\xi_k\|_{L^p} = \|\xi\|_{L^p}$. \square

Theorem 6.2.6 (Kahane–Khintchine inequality, Gaussian sums). *Let $0 < p < q < \infty$, and let $(x_n)_{n=1}^N$ be a sequence in a Banach space X . Then*

$$\left\| \sum_{n=1}^N \gamma_n x_n \right\|_{L^q(\Omega; X)} \leq \kappa_{q,p} \left\| \sum_{n=1}^N \gamma_n x_n \right\|_{L^p(\Omega; X)},$$

where $\kappa_{q,p}$ is the best constant in the Kahane–Khintchine inequality for Rademacher sums (Theorem 6.2.4).

Proof. Let $(\varepsilon_m^n)_{m,n \geq 1}$ be a doubly indexed Rademacher sequence, let $(\rho_k^n)_{k,n \geq 1}$ be as in Proposition 6.2.5, and let $S_k^N := \sum_{n=1}^N \rho_k^n x_n$. With $S^N := \sum_{n=1}^N \gamma_n x_n$, from Proposition 6.2.5 (applied first in L^q and later in L^p) and Theorem 6.2.4 we obtain

$$\begin{aligned} \|S^N\|_{L^q(\Omega;X)} &= \lim_{k \rightarrow \infty} \|S_k^N\|_{L^q(\Omega;X)} \\ &\leq \kappa_{q,p} \lim_{k \rightarrow \infty} \|S_k^N\|_{L^p(\Omega;X)} = \kappa_{q,p} \|S^N\|_{L^p(\Omega;X)}. \end{aligned}$$

□

6.2.c End-point bounds related to $p = 0$ and $q = \infty$

In this subsection we will derive some consequences of the Kahane–Khintchine inequalities. The results will be equally valid for both Rademacher and Gaussian sequences, and we denote by $(\xi_n)_{n \geq 1}$ a generic choice of either $(\varepsilon_n)_{n \geq 1}$ or $(\gamma_n)_{n \geq 1}$.

As a substitute of the false L^∞ limit of the Kahane–Khintchine inequalities, we have the following result on exponential square integrability:

Proposition 6.2.7. *Let $(\xi_n)_{n \geq 1}$ be either a Rademacher sequence $(\varepsilon_n)_{n \geq 1}$ or a Gaussian sequence $(\gamma_n)_{n \geq 1}$, and for given $x_1, \dots, x_N \in X$ put $S := \sum_{n=1}^N \xi_n x_n$. If*

$$0 < \delta < \frac{1}{2e\mathbb{E}\|S\|^2},$$

then

$$\mathbb{E}e^{\delta\|S\|^2} \leq \frac{1}{1 - 2e\delta\mathbb{E}\|S\|^2}.$$

Proof. We use Theorem 6.2.4 or 6.2.6 depending on the nature of ξ_n , and the inequality

$$\kappa_{2k,2}^{2k} \leq (2k-1)^k \leq 2^k k^k \leq 2^k e^k k!.$$

(Note that, in the first step, we are using the fact that the same, and in fact better, numerical bound for $\kappa_{2k,2}$ holds in the complex case as in the real case, although we only gave a proof with a slightly weaker version. Using this weaker version would require the replacement of $2e$ by a somewhat larger numerical factor.)

This gives

$$\begin{aligned} \mathbb{E}e^{\delta\|S\|^2} &= \sum_{k \geq 0} \frac{1}{k!} \delta^k \mathbb{E}\|S\|^{2k} = 1 + \sum_{k \geq 1} \frac{1}{k!} \delta^k \mathbb{E}\|S\|^{2k} \\ &\leq 1 + \sum_{k \geq 1} \frac{1}{k!} \delta^k \kappa_{2k,2}^{2k} (\mathbb{E}\|S\|^2)^k \leq 1 + \sum_{k \geq 1} \delta^k (2e)^k (\mathbb{E}\|S\|^2)^k. \end{aligned}$$

□

The following classical lemma allows us to extend the Kahane–Khintchine inequality to a version at the end-point $p = 0$.

Lemma 6.2.8 (Paley–Zygmund inequality). *Let ξ be a non-negative random variable. If $0 < \mathbb{E}\xi^2 \leq C(\mathbb{E}\xi)^2 < \infty$, then for all $0 < r < 1$ we have*

$$\mathbb{P}(\xi > r\mathbb{E}\xi) \geq \frac{(1-r)^2}{C}.$$

Proof. Using the non-negativity of ξ we have

$$(1-r)\mathbb{E}\xi = \mathbb{E}(\xi - r\mathbb{E}\xi) \leq \mathbb{E}(\mathbf{1}_{\{\xi > r\mathbb{E}\xi\}}(\xi - r\mathbb{E}\xi)) \leq \mathbb{E}(\mathbf{1}_{\{\xi > r\mathbb{E}\xi\}}\xi)$$

and therefore, by the Cauchy–Schwarz inequality,

$$(1-r)^2(\mathbb{E}\xi)^2 \leq (\mathbb{E}(\mathbf{1}_{\{\xi > r\mathbb{E}\xi\}}\xi))^2 \leq \mathbb{E}\mathbf{1}_{\{\xi > r\mathbb{E}\xi\}}\mathbb{E}\xi^2 \leq C\mathbb{E}\mathbf{1}_{\{\xi > r\mathbb{E}\xi\}}(\mathbb{E}\xi)^2.$$

The result follows upon dividing both sides by $(\mathbb{E}\xi)^2$. \square

Corollary 6.2.9. *Let $(\xi_n)_{n \geq 1}$ be either a Rademacher sequence $(\varepsilon_n)_{n \geq 1}$ or a Gaussian sequence $(\gamma_n)_{n \geq 1}$, and*

$$S := \sum_{n=1}^N \xi_n x_n,$$

where $x_n \in X$. If for some $\delta > 0$ and $q \in (0, \infty)$, we have

$$\mathbb{P}(\|S\| > \delta) \leq \eta < \frac{1}{\kappa_{2q,q}^2},$$

then

$$\|S\|_{L^q(\Omega; X)} \leq \frac{\delta}{(1 - \kappa_{2q,q}\sqrt{\eta})^{1/q}}.$$

Proof. We apply Lemma 6.2.8 to the random variable $\xi := \|S\|^q$. Note that the claim of the corollary is about bounding $(\mathbb{E}\xi)^{1/q}$ from above. We may assume that $\mathbb{E}\xi > \delta^q$, since otherwise the claim is trivial. By the Kahane–Khintchine inequality, we then have

$$0 < \mathbb{E}\xi^2 \leq \kappa_{2q,q}^{2q}(\mathbb{E}\xi)^2 < \infty.$$

Hence the assumption of Lemma 6.2.8 holds with $C = \kappa_{2q,q}^{2q}$. With $r := \delta^q/\mathbb{E}\xi \in (0, 1)$, the conclusion of the said lemma, in combination with the assumption, gives

$$\frac{(1 - \delta^q/\mathbb{E}\xi)^2}{\kappa_{2q,q}^2} = \frac{(1-r)^2}{C^2} \leq \mathbb{P}(\xi > r\mathbb{E}\xi) = \mathbb{P}(\xi > \delta^q) = \mathbb{P}(\|S\| > \delta) \leq \eta.$$

Solving for $\mathbb{E}\xi$, this gives the claimed inequality. \square

Remark 6.2.10. The obtained Kahane–Khintchine constant (in the case of real Rademacher sums) is asymptotically optimal in the following sense:

$$\lim_{\substack{p \leq q \\ p, q \rightarrow \infty}} \sqrt{\frac{p-1}{q-1}} \kappa_{q,p}^{\mathbb{R}} = 1,$$

where p, q both tend to ∞ under the condition $p \leq q$. Indeed, we already proved that $\sqrt{\frac{p-1}{q-1}} \kappa_{q,p}^{\mathbb{R}} \leq 1$ for all $1 < p < q < \infty$. To prove the converse bound, first note that $\kappa_{q,p}^{\mathbb{R}} \geq \|g\|_q / \|g\|_p$ where g is a real standard Gaussian random variable; this is immediate from (2.3). Hence it is enough to prove that $\|g\|_p / \sqrt{p-1}$ has a limit in $(0, \infty)$ as $p \rightarrow \infty$, and this is immediate from the exact formula (E.2) for $\|g\|_p$ and Stirling’s approximation of the Γ function. (The value of the limit is $e^{-1/2}$, but this is irrelevant.)

6.3 The random sequence spaces $\varepsilon^p(X)$ and $\gamma^p(X)$

For $1 \leq p < \infty$ and integers $N \geq 1$, we define $\varepsilon_N^p(X)$ and $\gamma_N^p(X)$ as the Banach spaces of sequences $(x_n)_{n=1}^N$ in X , endowed with the norms

$$\begin{aligned} \|(x_n)_{n=1}^N\|_{\varepsilon_N^p(X)} &:= \left\| \sum_{n=1}^N \varepsilon_n x_n \right\|_{L^p(\Omega; X)}, \\ \|(x_n)_{n=1}^N\|_{\gamma_N^p(X)} &:= \left\| \sum_{n=1}^N \gamma_n x_n \right\|_{L^p(\Omega; X)}. \end{aligned}$$

Similarly, we denote by $\varepsilon^p(X)$ and $\gamma^p(X)$ the Banach spaces of sequences $(x_n)_{n \geq 1}$ in X for which the sums $\sum_{n \geq 1} \varepsilon_n x_n$ and $\sum_{n \geq 1} \gamma_n x_n$ converge in $L^p(\Omega; X)$, endowed with the norms

$$\begin{aligned} \|(x_n)_{n \geq 1}\|_{\varepsilon^p(X)} &:= \left\| \sum_{n \geq 1} \varepsilon_n x_n \right\|_{L^p(\Omega; X)} = \sup_{N \geq 1} \left\| \sum_{n=1}^N \varepsilon_n x_n \right\|_{L^p(\Omega; X)}, \\ \|(x_n)_{n \geq 1}\|_{\gamma^p(X)} &:= \left\| \sum_{n \geq 1} \gamma_n x_n \right\|_{L^p(\Omega; X)} = \sup_{N \geq 1} \left\| \sum_{n=1}^N \gamma_n x_n \right\|_{L^p(\Omega; X)}. \end{aligned} \tag{6.11}$$

where in both lines the second identity follows from Fatou’s lemma (which gives the inequality ‘ \leq ’) and Proposition 6.1.5 (which gives the inequality ‘ \geq ’). Note that we have continuous inclusions $\ell^1(X) \hookrightarrow \varepsilon^p(X) \hookrightarrow \ell^\infty(X)$. Indeed, by another application of Proposition 6.1.5 and the triangle inequality one has

$$\sup_{n \geq 1} \|x_n\| \leq \|(x_n)_{n \geq 1}\|_{\varepsilon^p(X)} \leq \sum_{n \geq 1} \|x_n\|.$$

A similar result holds for $\gamma^p(X)$.

Although (6.11) provides two descriptions of the norms of $\varepsilon^p(X)$ and $\gamma^p(X)$, the finiteness of the suprema on the right hand sides does not imply the convergence of the corresponding infinite sums; a simple counterexample in the Rademacher case is the standard unit basis $(x_n)_{n \geq 1}$ of c_0 . For Banach spaces not containing a closed subspace isomorphic to c_0 , the theorem of Hoffmann-Jørgensen and Kwapien (Theorem 6.4.10) implies that the finiteness of the suprema in (6.11) does imply the convergence of the corresponding infinite sums.

The following result is immediate from the Kahane–Khintchine inequalities (Theorems 6.2.4 and 6.2.6); note in particular that these theorems immediately imply that a series $\sum_{n \geq 1} \varepsilon_n x_n$ or $\sum_{n \geq 1} \gamma_n x_n$ converges in $L^p(\Omega; X)$ if and only if it converges in $L^q(\Omega; X)$.

Proposition 6.3.1. *For all $1 \leq p, q < \infty$ we have natural isomorphisms of Banach spaces*

$$\varepsilon^p(X) \simeq \varepsilon^q(X), \quad \gamma^p(X) \simeq \gamma^q(X),$$

with norm equivalences

$$\kappa_{p,q}^{-1} \|(x_n)_{n \geq 1}\|_{\varepsilon^p(X)} \leq \|(x_n)_{n \geq 1}\|_{\varepsilon^q(X)} \leq \kappa_{q,p} \|(x_n)_{n \geq 1}\|_{\varepsilon^p(X)}$$

and

$$\kappa_{p,q}^{-1} \|(x_n)_{n \geq 1}\|_{\gamma^p(X)} \leq \|(x_n)_{n \geq 1}\|_{\gamma^q(X)} \leq \kappa_{q,p} \|(x_n)_{n \geq 1}\|_{\gamma^p(X)}.$$

and the same holds for finite sequences $(x_n)_{n=1}^N$, replacing $\varepsilon(X)$ and $\gamma(X)$ by $\varepsilon_N(X)$ and $\gamma_N^p(X)$, respectively.

Motivated by the above we will always write

$$\varepsilon_N(X) = \varepsilon_N^2(X), \quad \varepsilon(X) = \varepsilon^2(X),$$

and similarly

$$\gamma_N(X) = \gamma_N^2(X), \quad \gamma(X) = \gamma^2(X).$$

As a consequence of Proposition 6.1.15 we obtain:

Proposition 6.3.2. *For all $p \in [1, \infty)$ we have a continuous embedding $\gamma^p(X) \hookrightarrow \varepsilon^p(X)$ and*

$$\|(x_n)_{n \geq 1}\|_{\varepsilon^p(X)} \leq \frac{1}{\mathbb{E}|\gamma|} \|(x_n)_{n \geq 1}\|_{\gamma^p(X)}.$$

Recall from (6.2) that $\mathbb{E}|\gamma| = \sqrt{2/\pi}$ in the real case and $\mathbb{E}|\gamma| = \frac{1}{2}\sqrt{\pi}$ in the complex case.

It follows from Corollary 7.2.10 that $\gamma^p(X) = \varepsilon^p(X)$ isomorphically if X has finite cotype. Assuming the stronger property of K -convexity, the dual spaces of $\varepsilon^p(X)$ and $\gamma^p(X)$ will be identified in Section 7.4.c.

For each $p \in [1, \infty)$ the spaces $\varepsilon_N^p(\mathbb{K})$ and $\gamma_N^p(\mathbb{K})$ are isomorphic to ℓ_N^2 with uniform estimates in $N \geq 1$. Indeed, by Khintchine's inequality (6.9)

$$\kappa_{2,p}^{-1} \left(\sum_{n=1}^N |x_n|^2 \right)^{1/2} \leq \| (x_n)_{n=1}^N \|_{\varepsilon_N^p(\mathbb{K})} \leq \kappa_{p,2} \left(\sum_{n=1}^N |x_n|^2 \right)^{1/2},$$

and the same result holds for $\gamma_N^p(\mathbb{K})$. Passing to the limit $N \rightarrow \infty$ we obtain the isomorphisms $\varepsilon^p(\mathbb{K}) \simeq \gamma^p(\mathbb{K}) \simeq \ell^2$ with

$$\kappa_{2,p}^{-1} \left(\sum_{n \geq 1} |x_n|^2 \right)^{1/2} \leq \| (x_n)_{n \geq 1} \|_{\varepsilon^p(\mathbb{K})} \leq \kappa_{p,2} \left(\sum_{n \geq 1} |x_n|^2 \right)^{1/2},$$

and similarly for $\gamma^p(\mathbb{K})$.

6.3.a Coincidence with square function spaces when $X = L^q$

In the next proposition we give an explicit representation of $\varepsilon_N^p(X)$ and $\gamma_N^p(X)$ in the case $X = L^q(S)$ in terms of so-called square function norms.

Proposition 6.3.3. *Let (S, \mathcal{A}, μ) be a measure space and let $q \in [1, \infty)$. Then for all $x_1, \dots, x_N \in L^q(S)$ and $1 \leq p < \infty$ one has the square function estimate*

$$\frac{1}{c} \left\| \left(\sum_{n=1}^N |x_n|^2 \right)^{1/2} \right\|_{L^q(S)} \leq \left\| \sum_{n=1}^N \varepsilon_n x_n \right\|_{L^p(\Omega; L^q(S))} \leq C \left\| \left(\sum_{n=1}^N |x_n|^2 \right)^{1/2} \right\|_{L^q(S)}$$

with $c = \kappa_{2,q} \kappa_{q,p}$ and $C = \kappa_{p,q} \kappa_{q,2}$. The same estimates hold when the Rademacher sequence $(\varepsilon_n)_{n=1}^N$ is replaced by a Gaussian sequence $(\gamma_n)_{n=1}^N$.

In particular, the proposition implies that we have isomorphisms

$$\varepsilon_N^p(L^q(S)) \simeq \gamma_N^p(L^q(S)) \simeq L^q(S; \ell_N^2)$$

with isomorphism constants independent of N . Passing to the limit $N \rightarrow \infty$ we obtain the isomorphisms

$$\varepsilon^p(L^q(S)) \simeq \gamma^p(L^q(S)) \simeq L^q(S; \ell^2)$$

with the same isomorphism constants.

The above square function estimates for Rademacher and Gaussian sums will be generalised to Banach lattices with finite cotype in Theorem 7.2.13.

Proof of Proposition 6.3.3. We prove the result for Rademacher sums and Gaussian sums simultaneously. Set $X = L^q(S)$ for brevity and let $(\xi_n)_{n \geq 1}^N$ be a Rademacher sequence or a Gaussian sequence. In either case, by the Kahane–Khintchine inequalities we have

$$\frac{1}{\kappa_{q,p}} \left\| \sum_{n=1}^N \xi_n x_n \right\|_{L^q(\Omega; X)} \leq \left\| \sum_{n=1}^N \xi_n x_n \right\|_{L^p(\Omega; X)} \leq \kappa_{p,q} \left\| \sum_{n=1}^N \xi_n x_n \right\|_{L^q(\Omega; X)}. \quad (6.12)$$

Moreover, by Khintchine’s inequality (6.9), applied pointwise in S ,

$$\begin{aligned} \left\| \sum_{n=1}^N \xi_n x_n \right\|_{L^q(\Omega; X)}^q &= \int_S \mathbb{E} \left| \sum_{n=1}^N \xi_n x_n \right|^q d\mu \\ &\leq \kappa_{q,2}^q \int_S \left(\mathbb{E} \left| \sum_{n=1}^N \xi_n x_n \right|^2 \right)^{q/2} d\mu \\ &= \kappa_{q,2}^q \int_S \left(\sum_{n=1}^N |x_n|^2 \right)^{q/2} d\mu \\ &= \kappa_{q,2}^q \left\| \left(\sum_{n=1}^N |x_n|^2 \right)^{1/2} \right\|_{L^q(S)}^q. \end{aligned} \quad (6.13)$$

Reversing this reasoning we obtain

$$\left\| \left(\sum_{n=1}^N |x_n|^2 \right)^{1/2} \right\|_{L^q(S)}^q \leq \kappa_{2,q}^q \left\| \sum_{n=1}^N \xi_n x_n \right\|_{L^q(\Omega; X)}^q. \quad (6.14)$$

The desired estimates follow by combining (6.12), (6.13), (6.14). \square

6.3.b Dual and bi-dual of $\varepsilon_N^p(X)$ and $\gamma_N^p(X)$

Here we identify the dual and bi-dual of the spaces of random sequences of finite length.

Proposition 6.3.4. *Let $(\xi_n)_{n \geq 1}$ be a Rademacher or Gaussian sequence, let X be a Banach space, $N \geq 1$ and $p \in [1, \infty)$. The following isometries hold*

$$\begin{aligned} \xi_N^p(X) &\simeq \left\{ \sum_{n=1}^N \xi_n x_n : x_n \in X \right\} \subseteq L^p(\Omega; X), \\ [\xi_N^p(X)]^* &\simeq \left\{ \left[\sum_{n=1}^N \bar{\xi}_n x_n^* \right] : x_n^* \in X^* \right\} \subseteq L^{p'}(\Omega; X^*) / \bigcap_{n=1}^N \mathbf{N}(\mathbb{E}(\xi_n \cdot)), \\ [\xi_N^p(X)]^{**} &\simeq \xi_N^p(X^{**}) \simeq \left\{ \sum_{n=1}^N \xi_n x_n^{**} : x_n^{**} \in X^{**} \right\} \subseteq L^p(\Omega; X^{**}), \end{aligned}$$

under the natural duality pairings

$$\left\langle \sum_{n=1}^N \xi_n z_n, \left[\sum_{n=1}^N \bar{\xi}_n x_n^* \right] \right\rangle = \mathbb{E} \left\langle \sum_{n=1}^N \xi_n z_n, \sum_{n=1}^N \bar{\xi}_n x_n^* + F \right\rangle = \sum_{n=1}^N \langle z_n, x_n^* \rangle, \quad (6.15)$$

for any $F \in \bigcap_{n=1}^N \mathbf{N}(\mathbb{E}(\xi_n \cdot))$, and both $z_n = x_n \in X$ and $z_n = x_n^{**} \in X^{**}$.

Above, we have denoted by

$$\mathbf{N}(\mathbb{E}(\xi_n \cdot)) := \{F \in L^{p'}(\Omega; X^*) : \mathbb{E}(\xi_n F) = 0\}$$

the null space of the operator $\mathbb{E}(\xi_n \cdot) : L^{p'}(\Omega; X^*) \rightarrow X^*$.

Remark 6.3.5. Since the sequences $(\xi_n)_{n=1}^N$ and $(\bar{\xi}_n)_{n=1}^N$ are identically distributed, we have equal norms on the dual space given by

$$\begin{aligned} \|(x_n)_{n=1}^N\|_{[\mathcal{E}_N^p(X)]^*} &= \left\| \left[\sum_{n=1}^N \bar{\xi}_n x_n^* \right] \right\|_{L^{p'}(\Omega; X^*) / \bigcap_{n=1}^N \mathbf{N}(\mathbb{E}(\xi_n \cdot))} \\ &= \left\| \left[\sum_{n=1}^N \xi_n x_n^* \right] \right\|_{L^{p'}(\Omega; X^*) / \bigcap_{n=1}^N \mathbf{N}(\mathbb{E}(\bar{\xi}_n \cdot))}, \end{aligned}$$

but the latter has the disadvantage of obscuring the natural duality (6.15).

Proof of Proposition 6.3.4. For a systematic argument, we will prove a slightly more general statement for any sequence of independent random variables $\xi_n \in L^p(\Omega) \cap L^{p'}(\Omega)$ with $\mathbb{E}\xi_n = 0$ and $\mathbb{E}|\xi_n|^2 = 1$.

Case I: $(\Omega, \mathcal{A}, \mathbb{P})$ is finitely generated. (Note that this covers the case of the real version of $\mathcal{E}_N^p(X)$, but not the complex nor the Gaussian cases.) The assumption of a finitely generated measure space trivialises the duality theory of the L^p -spaces, including the vector-valued versions and the end points $p = 1, \infty$. Thus, with $E := L^p(\Omega; X)$, we have

$$E^* = L^{p'}(\Omega; X^*), \quad E^{**} = L^p(\Omega; X^{**}).$$

On E , we consider the bounded projection

$$\pi_N^\xi f := \sum_{n=1}^N \xi_n \mathbb{E}(\bar{\xi}_n f),$$

so that $\mathcal{E}_N^p(X) \simeq \mathbf{R}(\pi_N^\xi) \subseteq E$, where $\mathbf{R}(\pi_N^\xi)$ denotes the range of the operator π_N^ξ . By a general result about duals of subspaces and quotients (Proposition B.1.4), we have

$$\mathbf{R}(\pi_N^\xi)^* = E^* / \mathbf{R}(\pi_N^\xi)^\perp, \quad \mathbf{R}(\pi_N^\xi)^{**} = (E^* / \mathbf{R}(\pi_N^\xi)^\perp)^* = (\mathbf{R}(\pi_N^\xi)^\perp)^\perp,$$

where \perp denotes the annihilator. Moreover, for any projection P , we have

$$\mathbf{R}(P)^\perp = \mathbf{N}(P^*) = \mathbf{R}(I - P^*).$$

Using this repeatedly with both $P = \pi_N^\xi$ and $P = I - (\pi_N^\xi)^*$, we obtain

$$(\mathbf{R}(\pi_N^\xi)^\perp)^\perp = \mathbf{R}(I - (\pi_N^\xi)^*)^\perp = \mathbf{R}((\pi_N^\xi)^{**}).$$

For the specific operator π_N^ξ , it is immediate to verify that

$$\mathbf{N}((\pi_N^\xi)^*) = \bigcap_{n=1}^N \mathbf{N}(\mathbb{E}(\xi_n \cdot)),$$

whereas $(\pi_N^\xi)^{**} \in \mathcal{L}(E^{**})$ is given by the same formula as $\pi_N^\xi \in \mathcal{L}(E)$.

Case II: the general case via approximation. Note that it is obvious that the dual and bi-dual of $\xi_N^p(X) \simeq_{\xi, p, N} X^N$ coincide with $(X^*)^N$ and $(X^{**})^N$ as sets, so the only issue is identifying the correct norms on these spaces. The strategy is to do this by a reduction to Case I via approximation of ξ_n with simple functions.

Given $\delta > 0$, we can find independent *simple* functions s_n that share the properties $\mathbb{E}s_n = 0$ and $\mathbb{E}|s_n|^2 = 1$ with ξ_n and $\|s_n - \xi_n\|_{\max\{p, p'\}} \leq \delta$. The space $s_N^p(X)$ is then defined in the obvious way with ξ_n replaced by s_n . Since these functions can be considered in the finitely generated measure space $(\Omega, \sigma(s_1, \dots, s_N), \mathbb{P})$, Case I of the proof applies to give

$$\begin{aligned} \|\mathbf{x}^*\|_{[s_N^p(X)]^*} &= \|\mathbf{x}^*\|_{(s_N^p)'(X^*)} \quad \text{for all } \mathbf{x}^* = (x_n^*)_{n=1}^N \in (X^*)^N, \\ \|\mathbf{x}^{**}\|_{[s_N^p(X)]^{**}} &= \|\mathbf{x}^{**}\|_{(s_N^p)(X^{**})} \quad \text{for all } \mathbf{x}^{**} = (x_n^{**})_{n=1}^N \in (X^{**})^N, \end{aligned}$$

where we have given the following temporary notation for the norm on $(X^*)^N$ that we would like to identify as the dual norm corresponding to the norm $\|\cdot\|_{\xi_N^p(X)}$ on X^N :

$$\|(x_n^*)_{n=1}^N\|_{(\xi_N^p)'(X^*)} := \left\| \left[\sum_{n=1}^N \bar{\xi}_n x_n^* \right] \right\|_{L^{p'}(\Omega; X^*) / \bigcap_{n=1}^N \mathbf{N}(\mathbb{E}(\xi_n \cdot))}.$$

Testing the $L^{p'}(\Omega; X^*)$ -norm of $\sum_{n=1}^N \bar{\xi}_n x_n^* + F$, where $F \in \bigcap_{n=1}^N \mathbf{N}(\mathbb{E}(\xi_n \cdot))$ with $\xi_k x_k \in L^p(\Omega) \otimes X$, it is immediate that

$$\|(x_n^*)_{n=1}^N\|_{(\xi_N^p)'(X^*)} \geq \frac{1}{\|\xi_1\|_p} \max_{1 \leq k \leq N} \|x_k^*\|_{X^*}.$$

The bounds

$$\|(z_n)_{n=1}^N\|_{\xi_N^p(Z)} \geq \frac{1}{\|\xi_1\|_{p'}} \max_{1 \leq k \leq N} \|z_k\|_Z, \quad Z \in \{X, X^{**}\},$$

are similar and even easier, since no F is involved.

It is then immediate to check that

$$\left| \|\mathbf{x}\|_{s_N^p(X)} - \|\mathbf{x}\|_{\xi_N^p(X)} \right| \leq \sum_{n=1}^N \|s_n - \xi_n\|_p \|x_n\| \leq \delta N \|\xi_1\|_{p'} \|\mathbf{x}\|_{\xi_N^p(X)}.$$

On the other hand, let $F \in \bigcap_{n=1}^N \mathbf{N}(\mathbb{E}(\xi_n \cdot))$. Then

$$F' := F - \sum_{n=1}^N \bar{s}_n \mathbb{E}(s_n F) = F - \sum_{n=1}^N \bar{s}_n \mathbb{E}([s_n - \xi_n] F)$$

belongs to $\bigcap_{n=1}^N \mathbf{N}(\mathbb{E}(s_n \cdot))$, and hence

$$\begin{aligned} \|\mathbf{x}^*\|_{(s_N^p)'(X^*)} &\leq \left\| \sum_{n=1}^N \bar{s}_n x_n^* + F' \right\|_{L^{p'}(\Omega; X^*)} \\ &\leq \left\| \sum_{n=1}^N \bar{\xi}_n x_n^* + F \right\|_{L^{p'}(\Omega; X^*)} + \sum_{n=1}^N \|s_n - \xi_n\|_{p'} \|x_n^*\|_{X^*} \\ &\quad + \sum_{n=1}^N \|s_n\|_{p'} \|s_n - \xi_n\|_p \|F\|_{p'}, \end{aligned}$$

where moreover

$$\|F\|_{p'} \leq \left\| \sum_{n=1}^N \bar{\xi}_n x_n^* + F \right\|_{L^{p'}(\Omega; X)} + \sum_{n=1}^N \|\xi_n\|_{p'} \|x_n^*\|_{X^*}.$$

Taking the infimum over F , and bounding each $\|x_n^*\|_{X^*}$ by $\|\mathbf{x}^*\|_{(s_N^p)'(X^*)}$, we deduce an estimate of the form

$$\|\mathbf{x}^*\|_{(s_N^p)'(X^*)} \leq (1 + c_{N,p,\xi} \delta) \|\mathbf{x}^*\|_{(\xi_N^p)'(X^*)},$$

and an estimate reversing the roles of s and ξ is obtained in the same way. Moreover, by definition of duality, we also have

$$\begin{aligned} \|\mathbf{x}^*\|_{[\xi_N^p(X)]^*} &= \sup \left\{ |\langle \mathbf{x}, \mathbf{x}^* \rangle| : \|\mathbf{x}\|_{\xi_N^p(X)} \leq 1 \right\} \\ &\leq (1 + c_{N,p,\xi} \delta) \sup \left\{ |\langle \mathbf{x}, \mathbf{x}^* \rangle| : \|\mathbf{x}\|_{s_N^p(X)} \leq 1 \right\} \\ &= (1 + c_{N,p,\xi} \delta) \|\mathbf{x}^*\|_{[s_N^p(X)]^*}, \end{aligned}$$

and an estimate reversing the roles of s and ξ is again obtained in the same way.

Summarising, we have checked that

$$(1 + c_{N,p,\xi} \delta)^{-1} \leq \frac{\|\mathbf{x}^*\|_{(s_N^p)'(X^*)}}{\|\mathbf{x}^*\|_{(\xi_N^p)'(X^*)}}, \quad \frac{\|\mathbf{x}^*\|_{[s_N^p(X)]^*}}{\|\mathbf{x}^*\|_{[\xi_N^p(X)]^*}} \leq (1 + c_{N,p,\xi} \delta),$$

and we know from Case I that $\|\mathbf{x}^*\|_{[s_N^p(X)]^*} = \|\mathbf{x}^*\|_{(s_N^p)'(X^*)}$. Thus

$$\begin{aligned} \|\mathbf{x}^*\|_{[\xi_N^p(X)]^*} &\leq (1 + c_{N,p,\xi}\delta)\|\mathbf{x}^*\|_{[s_N^p(X)]^*} \\ &= (1 + c_{N,p,\xi}\delta)\|\mathbf{x}^*\|_{(s_N^p)'(X)} \leq (1 + c_{N,p,\xi}\delta)^2\|\mathbf{x}^*\|_{(\xi_N^p)'(X)}, \end{aligned}$$

and an estimate in the reverse direction is similar. Thus

$$(1 + c_{N,p,\xi}\delta)^{-2} \leq \frac{\|\mathbf{x}^*\|_{[\xi_N^p(X)]^*}}{\|\mathbf{x}^*\|_{(\xi_N^p)'(X)}} \leq (1 + c_{N,p,\xi}\delta)^2.$$

This bound holds for arbitrary $\delta > 0$ and is independent of the approximating functions s_n (which depend on δ). Letting $\delta \rightarrow 0$, we deduce that $\|\mathbf{x}^*\|_{[\xi_N^p(X)]^*} = \|\mathbf{x}^*\|_{(\xi_N^p)'(X)}$. The equality of the bi-dual norms, namely $\|\mathbf{x}^{**}\|_{[\xi_N^p(X)]^{**}} = \|\mathbf{x}^{**}\|_{\xi_N^p(X^{**})}$, is obtained in a similar way. \square

Remark 6.3.6 (Rademacher projections). In the case of the space $\varepsilon_N^p(X)$, the projections $\pi_N^\varepsilon =: \pi_N$, which played a key role in the previous proof, are called the *Rademacher projections*. They will be studied in detail in Section 7.4.a in connection with the so-called K -convexity property.

6.4 Convergence of random series

We will now present some applications of the techniques developed so far to the convergence of infinite random series. The main results of this section, the Itô–Nisio theorem and the Hoffmann–Jørgensen–Kwapień theorem, provide two examples of ‘weak equals strong’ results: if the random series has sufficient ‘structure’, a rather weak *a priori* assumption on the convergence or boundedness of the partial sums implies stronger forms of convergence.

6.4.a Itô–Nisio equivalence of different modes of convergence

The main result of this subsection is the Itô–Nisio theorem, which states that for the partial sums of a sequence of independent symmetric X -valued random variables, convergence in probability and almost sure convergence are equivalent and can both be tested along functionals. A version of this theorem for L^p -martingales has already been proved in Chapter 3. In contrast to the martingale setting, the present version for random sums does not impose any integrability assumptions on the random variables.

Theorem 6.4.1 (Itô–Nisio). *Let $(\xi_n)_{n \geq 1}$ be a sequence of independent real-symmetric X -valued random variables, put $S_n := \sum_{j=1}^n \xi_j$, and let S be an X -valued random variable. The following assertions are equivalent:*

- (1) *for all $x^* \in X^*$ we have $\lim_{n \rightarrow \infty} \langle S_n, x^* \rangle = \langle S, x^* \rangle$ almost surely;*
- (2) *for all $x^* \in X^*$ we have $\lim_{n \rightarrow \infty} \langle S_n, x^* \rangle = \langle S, x^* \rangle$ in probability;*

- (3) $\lim_{n \rightarrow \infty} S_n = S$ almost surely;
 (4) $\lim_{n \rightarrow \infty} S_n = S$ in probability.

If these equivalent conditions hold and if $\sup_{n \geq 1} \mathbb{E} \|S_n\|^p < \infty$ for some $1 \leq p < \infty$, then

$$\lim_{n \rightarrow \infty} \mathbb{E} \|S_n - S\|^p = 0.$$

It is important to observe that the condition (1) is strictly stronger than the requirement that “for all $x^* \in X^*$ the sequence $\langle S_n, x^* \rangle$ converges almost surely”; namely, requiring the limit to take the form $\langle S, x^* \rangle$ for a fixed X -valued random variable S imposes a non-trivial constraint. The same applies to condition (2). See Remark 6.4.3 below for details.

Consequences of the Itô–Nisio theorem

Before going to the proof, we point out immediate corollaries for the Rademacher and Gaussian series of our primary interest, which only uses Theorem 6.4.1 (4) \Leftrightarrow (3)

Corollary 6.4.2. *For any sequence $(x_n)_{n \geq 1}$ in X the following assertions are equivalent:*

- (1) for all $p \in [1, \infty)$ the sum $\sum_{n \geq 1} \varepsilon_n x_n$ converges in $L^p(\Omega; X)$;
 (2) for some $p \in [1, \infty)$ the sum $\sum_{n \geq 1} \varepsilon_n x_n$ converges in $L^p(\Omega; X)$;
 (3) the sum $\sum_{n \geq 1} \varepsilon_n x_n$ converges in probability;
 (4) the sum $\sum_{n \geq 1} \varepsilon_n x_n$ converges almost surely.

If these equivalent conditions hold, then for all $\delta > 0$,

$$\mathbb{E} \exp \left(\delta \left\| \sum_{n \geq 1} \varepsilon_n x_n \right\|^2 \right) < \infty.$$

Proof. The implications (1) \Rightarrow (2) \Rightarrow (3) are clear and the equivalence (3) \Leftrightarrow (4) follows from Theorem 6.4.1 (4) \Leftrightarrow (3).

(3) \Rightarrow (1): Fix $p \in [1, \infty)$. Suppose that the partial sums $S_n = \sum_{j=1}^n \varepsilon_j x_j$ converge to $S = \sum_{j \geq 1} \varepsilon_j x_j$ in probability. It suffices to show that $(S_n)_{n \geq 1}$ is a Cauchy sequence in $L^p(\Omega; X)$. Let $\delta \in (0, 1)$ be arbitrary and let $N \geq 1$ be such that for all $m, n \geq N$,

$$\mathbb{P}(\|S_n - S_m\| > \delta/2) < \frac{1}{4\kappa_{2p,p}^{2p}} =: \eta.$$

Applying Corollary 6.2.9 to the random sums $S_n - S_m$ with $m, n \geq N$, we find that

$$\|S_n - S_m\|_{L^p(\Omega; X)} \leq \frac{\delta/2}{1 - \kappa_{2p,p} \sqrt{\eta}} = \delta,$$

which is the required Cauchy criterion.

It remains to prove the exponential square-integrability. If

$$\delta < \frac{1}{2e\mathbb{E}\|S\|^2} \leq \frac{1}{2e\mathbb{E}\|S_m\|^2},$$

it follows from Fatou's lemma, Proposition 6.2.7 and monotone convergence that

$$\mathbb{E}e^{\delta\|S\|^2} \leq \lim_{m \rightarrow \infty} \mathbb{E}e^{\delta\|S_m\|^2} \leq \lim_{m \rightarrow \infty} \frac{1}{1 - 2e\delta\mathbb{E}\|S_m\|^2} = \frac{1}{1 - 2e\delta\mathbb{E}\|S\|^2}. \quad (6.16)$$

In general, we have

$$\mathbb{E}e^{\delta\|S\|^2} \leq \mathbb{E}e^{2\delta(\|S-S_n\|^2 + \|S_n\|^2)} \leq (\mathbb{E}e^{4\delta\|S-S_n\|^2})^{1/2} (\mathbb{E}e^{4\delta\|S_n\|^2})^{1/2},$$

where the last estimate follows from the Cauchy–Schwarz inequality. The second term is finite, since $S_n \in L^\infty(\Omega; X)$. If we choose $n \geq 1$ so large that $4\delta < (2e\mathbb{E}\|S - S_n\|^2)^{-1}$, then the first term is finite by (6.16) applied to $S - S_n$ in place of S and 4δ in place of δ . \square

Remark 6.4.3. Applying Corollary 6.4.2 to each scalar sequence $(\langle x_n, x^* \rangle)_{n \geq 1}$ in place of $(x_n)_{n \geq 1}$, we find in particular that the following are equivalent:

- (2') for all $x^* \in X^*$, the sum $\sum_{n \geq 1} \varepsilon_n \langle x_n, x^* \rangle$ converges in $L^2(\Omega)$;
- (3') for all $x^* \in X^*$, the sum $\sum_{n \geq 1} \varepsilon_n \langle x_n, x^* \rangle$ converges in probability;
- (4') for all $x^* \in X^*$, the sum $\sum_{n \geq 1} \varepsilon_n \langle x_n, x^* \rangle$ converges almost surely.

But (2') is obviously equivalent to

$$(2'') \text{ for all } x^* \in X^*, \text{ the sum } \sum_{n \geq 1} |\langle x_n, x^* \rangle|^2 \text{ converges.}$$

If $X = H$ is a Hilbert space, then (2'') (and hence the other equivalent conditions above) holds in particular when $x_n = h_n$ is an orthonormal sequence. On the other hand, the condition (1) of Corollary 6.4.2 for this sequence, with $p = 2$, would be equivalent to the convergence of $\sum_{n \geq 1} \|h_n\|^2$, which is obviously false. Hence we see that the equivalent conditions (2') through (4') above are in general strictly weaker than the equivalent conditions (1) through (4) of Corollary 6.4.2. This shows in particular that the conditions that $\lim_{n \rightarrow \infty} \langle S_n, x^* \rangle = \langle S, x^* \rangle$ in probability (resp. almost surely) in the Itô–Nisio theorem cannot be replaced by the condition that $\langle S_n, x^* \rangle$ converges in probability (resp. almost surely).

For Gaussian sequences, we have an almost complete analogue of Corollary 6.4.2, the only difference being that the exponential square integrability only holds for small enough $\delta > 0$:

Corollary 6.4.4. *For any sequence $(x_n)_{n \geq 1}$ in X the following are equivalent:*

- (1) for all $p \in [1, \infty)$ the sum $\sum_{n \geq 1} \gamma_n x_n$ converges in $L^p(\Omega; X)$;
- (2) for some $p \in [1, \infty)$ the sum $\sum_{n \geq 1} \gamma_n x_n$ converges in $L^p(\Omega; X)$;

- (3) the sum $\sum_{n \geq 1} \gamma_n x_n$ converges in probability;
(4) the sum $\sum_{n \geq 1} \gamma_n x_n$ converges almost surely.

If these equivalent conditions hold, then for small enough $\delta > 0$,

$$\mathbb{E} \exp \left(\delta \left\| \sum_{n \geq 1} \gamma_n x_n \right\|^2 \right) < \infty.$$

Proof. This is basically the same as the proof of Corollary 6.4.2, but using the Gaussian version of the Kahane–Khintchine inequality and its corollaries instead of the Rademacher version. The only difference is that we only claim the exponential square-integrability for small enough $\delta > 0$, which allows us to skip the last part of the proof. \square

Proof of the Itô–Nisio theorem

We will give the proof of Theorem 6.4.1 in two parts:

Proof of Theorem 6.4.1, Part I. Here we check that (4) \Leftrightarrow (3) \Rightarrow (1) \Leftrightarrow (2), and verify the final claim of the theorem. The remaining implication (2) \Rightarrow (4) will be verified in Part II of the proof after developing some auxiliary results.

(3) \Rightarrow (1) is clear.

(3) \Rightarrow (4) is a special case of the general relation between convergence almost surely and in probability (Proposition E.1.5). (1) \Rightarrow (2) is an application of the same result to each scalar function sequence $\langle S_n, x^* \rangle$.

(4) \Rightarrow (3): By the triangle inequality and Lévy’s inequality (Proposition 6.1.12), we have

$$\begin{aligned} \mathbb{P} \left(\bigcup_{m, n \geq N} \{ \|S_n - S_m\| > \varepsilon \} \right) &\leq 2\mathbb{P} \left(\bigcup_{n \geq N} \{ \|S_n - S_N\| > \varepsilon/2 \} \right) \\ &= \lim_{k \rightarrow \infty} 2\mathbb{P} \left(\max_{N \leq n \leq k} \|S_n - S_N\| > \varepsilon/2 \right) \leq \limsup_{k \rightarrow \infty} 4\mathbb{P}(\|S_k - S_N\| > \varepsilon/2). \end{aligned}$$

If S_n converges in probability, the limit as $N \rightarrow \infty$ of the right side, and hence of the left side, vanishes for every $\varepsilon > 0$. Thus

$$\begin{aligned} &\mathbb{P} \left(\bigcup_{k \geq 1} \bigcap_{N \geq 1} \bigcup_{m, n \geq N} \{ \|S_n - S_m\| > k^{-1} \} \right) \\ &\leq \sum_{k \geq 1} \lim_{N \rightarrow \infty} \mathbb{P} \left(\bigcup_{m, n \geq N} \{ \|S_n - S_m\| > \varepsilon \} \right) = 0. \end{aligned}$$

The set on the left is precisely the set in which $(S_n)_{n \geq 1}$ fails to be Cauchy, and hence $(S_n)_{n \geq 1}$ is almost surely Cauchy, hence convergent, to some \tilde{S} . On the other hand, since $S_n \rightarrow S$ in probability, we have $S_{n_k} \rightarrow S$ almost surely along a subsequence (Proposition E.1.5), and hence $\tilde{S} = S$. So we have proved that $S_n \rightarrow S$ almost surely as claimed.

(2) \Rightarrow (1): This follows by applying the previous implication to $\langle S_n, x^* \rangle$ in place of S_n .

It remains to prove the assertion about L^p -convergence. First we note that $\mathbb{E}\|S\|^p < \infty$ by Fatou's lemma. Moreover, we have $S = S_n + (S - S_n)$ with S_n and $S - S_n$ independent, and therefore $\mathbb{E}\|S_n\|^p \leq \mathbb{E}\|S\|^p$ by Proposition 6.1.5. Hence by an integration by parts and Lévy's inequality (Proposition 6.1.12),

$$\begin{aligned} \mathbb{E} \sup_{1 \leq k \leq n} \|S_k\|^p &= \int_0^\infty pr^{p-1} \mathbb{P}\left(\sup_{1 \leq k \leq n} \|S_k\| > r\right) dr \\ &\leq 2 \int_0^\infty pr^{p-1} \mathbb{P}(\|S_n\| > r) dr = 2\mathbb{E}\|S_n\|^p \leq 2\mathbb{E}\|S\|^p. \end{aligned}$$

By the monotone convergence theorem, $\mathbb{E} \sup_{k \geq 1} \|S_k\|^p \leq 2\mathbb{E}\|S\|^p$. Hence $\lim_{n \rightarrow \infty} \mathbb{E}\|S_n - S\|^p = 0$ by the dominated convergence theorem. \square

Tightness

For the proof of the remaining implication in the Itô–Nisio theorem, we need some elements of the notion of uniform tightness. In order to introduce this property, we will first prove that individual random variables are tight.

Proposition 6.4.5 (Tightness). *Every X -valued random variable is tight, i.e., for every $\varepsilon > 0$ there exists a compact set $K \subseteq X$ such that $\mathbb{P}(X \notin K) < \varepsilon$.*

Proof. Since the range of any strongly measurable function ξ is contained in a separable closed subspace of X we may assume that X is separable. Let $(x_n)_{n \geq 1}$ be a dense sequence in X and fix $\varepsilon > 0$. For each integer $k \geq 1$ the closed balls $\overline{B}(x_n, \frac{1}{k}) = \{x \in X : \|x - x_n\| \leq \frac{1}{k}\}$ cover x , and therefore there exists an index $N_k \geq 1$ such that

$$\mathbb{P}\left(\xi \in \bigcup_{n=1}^{N_k} \overline{B}_X\left(x_n, \frac{1}{k}\right)\right) \geq 1 - \frac{\varepsilon}{2^k}.$$

The set

$$K := \bigcap_{k \geq 1} \bigcup_{n=1}^{N_k} \overline{B}_X\left(x_n, \frac{1}{k}\right)$$

is closed and totally bounded, and therefore compact. Moreover,

$$\mathbb{P}(\xi \in X \setminus K) \leq \sum_{k \geq 1} \frac{\varepsilon}{2^k} = \varepsilon.$$

\square

A family \mathcal{X} of X -valued random variables is called *uniformly tight* if for every $\varepsilon > 0$ there exists a compact set K in X such that

$$\mathbb{P}(\xi \notin K) < \varepsilon, \quad \xi \in \mathcal{X}.$$

Lemma 6.4.6. *If \mathcal{X} is uniformly tight, then $\mathcal{X} - \mathcal{X} = \{\xi_1 - \xi_2 : \xi_1, \xi_2 \in \mathcal{X}\}$ is uniformly tight.*

Proof. Let $\varepsilon > 0$ be arbitrary and fixed. Choose a compact set K in X such that $\mathbb{P}(\xi \notin K) < \varepsilon$ for all $\xi \in \mathcal{X}$. The set $L = \{x - y : x, y \in K\}$ is compact, being the image of the compact set $K \times K$ under the continuous map $(x, y) \mapsto x - y$. Since $\xi_1(\omega), \xi_2(\omega) \in K$ implies $\xi_1(\omega) - \xi_2(\omega) \in L$,

$$\mathbb{P}(\xi_1 - \xi_2 \notin L) \leq \mathbb{P}(\xi_1 \notin K) + \mathbb{P}(\xi_2 \notin K) < 2\varepsilon.$$

□

The proof below will also make use of the theory of *characteristic functions*, which the reader may recall from Appendix E.1.c.

Proof of Theorem 6.4.1, Part II. It remains to prove (2) \Rightarrow (4). We split this into two steps.

Step 1 – In this step we prove that the sequence $(S_n)_{n \geq 1}$ is uniformly tight.

For all $m \geq n$ and $x^* \in X^*$ the random variables $\langle S_m - S_n, x^* \rangle$ and $\pm \langle S_n, x^* \rangle$ are independent. Hence by Proposition E.1.12, $\langle S - S_n, x^* \rangle$ and $\pm \langle S_n, x^* \rangle$ are independent. Next we claim that S and $S - 2S_n$ are identically distributed. Denote their distributions by μ and λ_n , respectively. By the independence of $\langle S - S_n, x^* \rangle$ and $\pm \langle S_n, x^* \rangle$ and the real-symmetry of S_n , for all $x^* \in X^*$ we have

$$\begin{aligned} \widehat{\mu}(x^*) &= \mathbb{E}(\exp(i\Re \langle S, x^* \rangle)) = \mathbb{E}(\exp(i\Re \langle S - S_n, x^* \rangle)) \mathbb{E}(\exp(i\Re \langle S_n, x^* \rangle)) \\ &= \mathbb{E}(\exp(i\Re \langle S - S_n, x^* \rangle)) \mathbb{E}(\exp(i\Re \langle -S_n, x^* \rangle)) \\ &= \mathbb{E}(\exp(i\Re \langle S - 2S_n, x^* \rangle)) \\ &= \widehat{\lambda}_n(x^*). \end{aligned}$$

By Theorem E.1.16, this shows that $\mu = \lambda_n$ and the claim is proved.

Given $\varepsilon > 0$ we can find a compact set $K \subseteq X$ with $\mu(\mathbb{C}K) = \mathbb{P}(S \notin K) < \varepsilon$. The set $L := \frac{1}{2}(K - K)$ is compact as well, and arguing as in the proof of Lemma 6.4.6 we have

$$\mathbb{P}(S_n \notin L) \leq \mathbb{P}(S \notin K) + \mathbb{P}(S - 2S_n \notin K) = 2\mathbb{P}(S \notin K) < 2\varepsilon.$$

It follows that $\mathbb{P}(S_n \notin L) < 2\varepsilon$ for all $n \geq 1$, and therefore the sequence $(S_n)_{n \geq 1}$ is uniformly tight.

Step 2 – By Lemma 6.4.6, the sequence $(S_n - S)_{n \geq 1}$ is uniformly tight. Let ν_n denote the distribution of $S_n - S$. We need to prove that for all $\varepsilon > 0$ and $r > 0$ there exists an index $N \geq 1$ such that

$$\mathbb{P}(\|S_n - S\| \geq r) = \nu_n(\mathbb{C}B(0, r)) < \varepsilon, \quad n \geq N,$$

Suppose, for a contradiction, that such an N does not exist for certain $\varepsilon > 0$ and $r > 0$. Then there exists a subsequence $(S_{n_k})_{k \geq 1}$ such that

$$\nu_{n_k}(\mathbb{C}B(0, r)) \geq \varepsilon, \quad k \geq 1.$$

On the other hand, by uniform tightness we find a compact set K such that $\nu_{n_k}(K) \geq 1 - \frac{1}{2}\varepsilon$ for all $k \geq 1$. It follows that

$$\nu_{n_k}(K \cap \mathbb{C}B(0, r)) \geq \frac{1}{2}\varepsilon, \quad k \geq 1.$$

By covering the compact set $K \cap \mathbb{C}B(0, r)$ with finitely many open balls of radius $\frac{1}{2}r$ and passing to a subsequence, we find a ball B such that $0 \notin \bar{B}$ and a number $\delta > 0$ such that

$$\nu_{n_{k_j}}(K \cap B) = \mathbb{P}(S_{n_{k_j}} - S \in K \cap B) \geq \delta, \quad j \geq 1.$$

By the Hahn–Banach separation theorem, there exists a functional $x^* \in X^*$ such that $\Re\langle x, x^* \rangle \geq 1$ for all $x \in B$. For all $\omega \in \{S_{n_{k_j}} - S \in K \cap B\}$ it follows that $|\langle S_{n_{k_j}}(\omega) - S(\omega), x^* \rangle| \geq 1$. Hence

$$\mathbb{P}(|\langle S_{n_{k_j}} - S, x^* \rangle| \geq 1) \geq \mathbb{P}(S_{n_{k_j}} - S \in K \cap B) \geq \delta$$

Thus, $\langle S_{n_k}, x^* \rangle$ fails to converge to $\langle S, x^* \rangle$ in probability. This contradiction concludes the proof. \square

6.4.b Boundedness implies convergence if and only if $c_0 \not\subseteq X$

In this section we give a sufficient condition for almost sure convergence in terms of boundedness in probability. It will play an important role in Chapter 9.

Definition 6.4.7. A sequence $(\xi_n)_{n \geq 1}$ of X -valued random variables is said to be bounded in probability if for all $\varepsilon > 0$ there exists an $r > 0$ such that

$$\mathbb{P}(\|\xi_n\| > r) < \varepsilon, \quad n \geq 1.$$

To give a quick example, Chebyshev’s inequality

$$\mathbb{P}\{|\xi| \geq r\} = \frac{1}{r^p} \int_{\{|\xi|^p \geq r^p\}} r^p \, d\mathbb{P} \leq \frac{1}{r^p} \int_{\{|\xi|^p \geq r^p\}} |\xi|^p \, d\mathbb{P} \leq \frac{1}{r^p} \mathbb{E}|\xi|^p$$

implies that uniformly bounded families in $L^p(\Omega; X)$ are bounded in probability.

Proposition 6.4.8. If the sequence $(\xi_n)_{n \geq 1}$ of X -valued random variables converges in probability, then $(\xi_n)_{n \geq 1}$ is bounded in probability.

Proof. Suppose $\lim_{n \rightarrow \infty} \xi_n = \xi$ in probability and let $\varepsilon > 0$ be given. Choose $m_0 > 0$ so large that $\mathbb{P}(\|\xi\| > m_0/2) < \frac{\varepsilon}{2}$, and choose $N \geq 1$ such that $\mathbb{P}(\|\xi_n - \xi\| > m_0/2) < \varepsilon/2$ for all $n \geq N$. Then, for $n \geq N$,

$$\mathbb{P}(\|\xi_n\| > m_0) \leq \mathbb{P}(\|\xi_n - \xi\| > m_0/2) + \mathbb{P}(\|\xi\| > m_0/2) < \varepsilon.$$

For $n = 1, \dots, N - 1$ choose $m_n > 0$ so large that $\mathbb{P}(\|\xi_n\| > m_n) < \varepsilon$. Then, with $r := \max\{m_0, m_1, \dots, m_{N-1}\}$ we have $\mathbb{P}(\|\xi_n\| > r) < \varepsilon$ for all $n \geq 1$. \square

Our next aim is to prove a result on equivalence of almost sure boundedness and boundedness in probability for the partial sums of symmetric X -valued random variables.

Proposition 6.4.9. *Let $(\xi_n)_{n \geq 1}$ be a sequence of independent real-symmetric X -valued random variables and let $S_n = \sum_{j=1}^n \xi_j$. The following assertions are equivalent:*

- (1) *the sequence $(S_n)_{n \geq 1}$ is bounded almost surely;*
- (2) *the sequence $(S_n)_{n \geq 1}$ is bounded in probability.*

Proof. (1) \Rightarrow (2): Fix $\varepsilon > 0$ and choose $r \geq 0$ so that $\mathbb{P}(\sup_{n \geq 1} \|S_n\| > r) < \varepsilon$. Then

$$\mathbb{P}(\|S_n\| > r) \leq \mathbb{P}(\sup_{j \geq 1} \|S_j\| > r) < \varepsilon$$

for all $n \geq 1$, and therefore $(S_n)_{n \geq 1}$ is bounded in probability.

(2) \Rightarrow (1): Fix $\varepsilon > 0$ arbitrary and choose $r \geq 0$ so large that $\mathbb{P}(\|S_n\| > r) < \varepsilon$ for all $n \geq 1$. By Lévy's inequality (Proposition 6.1.12),

$$\mathbb{P}\left(\sup_{1 \leq j \leq n} \|S_j\| > r\right) \leq 2\mathbb{P}(\|S_n\| > r) < 2\varepsilon.$$

It follows that $\mathbb{P}(\sup_{j \geq 1} \|S_j\| > r) \leq 2\varepsilon$. In particular, $\mathbb{P}(\sup_{j \geq 1} \|S_j\| = \infty) \leq 2\varepsilon$. Since $\varepsilon > 0$ was arbitrary, this shows that $(S_n)_{n \geq 1}$ is bounded almost surely. \square

Theorem 6.4.10 (Hoffmann-Jørgensen and Kwapien). *For a Banach space X the following assertions are equivalent:*

- (1) *for all sequences $(\xi_n)_{n \geq 1}$ of independent real-symmetric X -valued random variables, the almost sure boundedness of the partial sum sequence $(S_n)_{n \geq 1}$ implies the almost sure convergence of $(S_n)_{n \geq 1}$;*
- (2) *for all sequences $(x_n)_{n \geq 1}$ in X , the almost sure boundedness of the partial sums of $\sum_{n \geq 1} r_n x_n$ implies $\lim_{n \rightarrow \infty} x_n = 0$;*
- (3) *the space X contains no closed subspace isomorphic to c_0 .*

Proof. (1) \Rightarrow (2) is trivial.

(2) \Rightarrow (3): Suppose that X contains a subspace isomorphic to c_0 and let e_n denote the n -th unit vector of c_0 . The sum $\sum_{n \geq 1} r_n(\omega)e_n$ fails to converge for all $\omega \in \Omega$ while its partial sums are uniformly bounded.

(3) \Rightarrow (2): Suppose that (2) does not hold. Then there exists a sequence $(x_n)_{n \geq 1}$ in X with

$$\delta := \limsup_{n \rightarrow \infty} \|x_n\| > 0 \tag{6.17}$$

such that the partial sums of $\sum_{n \geq 1} r_n x_n$ are bounded almost surely.

Let \mathcal{G} denote the σ -algebra generated by the sequence $(r_n)_{n \geq 1}$. We claim that for all $B \in \mathcal{G}$,

$$\lim_{n \rightarrow \infty} \mathbb{P}(B \cap \{r_n = -1\}) = \lim_{n \rightarrow \infty} \mathbb{P}(B \cap \{r_n = 1\}) = \frac{1}{2} \mathbb{P}(B). \quad (6.18)$$

For all $B \in \mathcal{G}_N$, the σ -algebra generated by r_1, \dots, r_N , this follows immediately from the fact that r_n is independent of \mathcal{G}_N for all $n > N$. The case for $B \in \mathcal{G}$ now follows from the general fact of measure theory (see Lemma A.1.2) that for any $B \in \mathcal{G}$ and any $\varepsilon > 0$ there exist N sufficiently large and $B_N \in \mathcal{G}_N$ such that $\mathbb{P}(B_N \Delta B) < \varepsilon$.

Choose $M \geq 0$ in such a way that

$$\mathbb{P}\left(\sup_{n \geq 1} \left\| \sum_{j=1}^n r_j x_j \right\| \leq M\right) > \frac{1}{2}.$$

We will construct a subsequence $(x_{n_j})_{j \geq 1}$ such that $\|x_{n_j}\| \geq \frac{1}{2}\delta$ for every j , and for any finite choice $a_1, \dots, a_k \in \{-1, 1\}$ one has $\|\sum_{j=1}^k a_j x_{n_j}\| \leq M$. The Bessaga–Pelczyński criterion (Theorem 1.2.40) then implies that X contains a copy of c_0 .

By (6.17) and (6.18) we can find an index $n_1 \geq 1$ such that for either choice of $a_1 \in \{-1, 1\}$,

$$\mathbb{P}\left(\sup_{n \geq 1} \left\| \sum_{j=1}^n r_j x_j \right\| \leq M, \quad r_{n_1} = a_1\right) > \frac{1}{4}, \quad \|x_{n_1}\| \geq \frac{1}{2}\delta.$$

Continuing inductively, we find a sequence $1 \leq n_1 < n_2 < \dots$ such that for any choice of $a_1, \dots, a_k \in \{-1, 1\}$, we have

$$\mathbb{P}\left(\sup_{n \geq 1} \left\| \sum_{j=1}^n r_j x_j \right\| \leq M, \quad r_{n_1} = a_1, \dots, r_{n_k} = a_k\right) > \frac{1}{2^{k+1}}, \quad \|x_{n_k}\| \geq \frac{\delta}{2}.$$

Define

$$r'_m := \begin{cases} r_m, & \text{if } m = n_j \text{ for some } j \geq 1, \\ -r_m, & \text{otherwise.} \end{cases}$$

Then both $(r_m)_{m \geq 1}$ and $(r'_m)_{m \geq 1}$ are real Rademacher sequences. Fixing $a_1, \dots, a_k \in \{-1, 1\}$, we find that

$$\mathbb{P}\left(\sup_{n \geq 1} \left\| \sum_{j=1}^n r'_j x_j \right\| \leq M, \quad r_{n_1} = a_1, \dots, r_{n_k} = a_k\right) > \frac{1}{2^{k+1}}.$$

Since $\mathbb{P}(r_{n_1} = a_1, \dots, r_{n_k} = a_k) = \frac{1}{2^k}$, the event

$$\left\{ \sup_{n \geq 1} \left\| \sum_{j=1}^n r_j x_j \right\| \leq M, \quad \sup_{n \geq 1} \left\| \sum_{j=1}^n r'_j x_j \right\| \leq M, \quad r_{n_1} = a_1, \dots, r_{n_k} = a_k \right\}$$

has positive probability and hence is non-empty. Choosing any ω in the above event we obtain

$$\left\| \sum_{j=1}^k a_j x_{n_j} \right\| = \left\| \frac{1}{2} \sum_{j=1}^{n_k} r_j(\omega) x_j + \frac{1}{2} \sum_{j=1}^{n_k} r'_j(\omega) x_j \right\| \leq M.$$

(2) \Rightarrow (1): Suppose the partial sums $S_n = \sum_{n=1}^N \xi_n$ are bounded almost surely but fail to converge almost surely. Then by Theorem 6.4.1 it fails to be Cauchy in probability, and there exist $r > 0$, $\varepsilon > 0$, and an increasing sequence $1 \leq n_1 < n_2 < \dots$ such that

$$\mathbb{P}(\|S_{n_{k+1}} - S_{n_k}\| > r) \geq \varepsilon, \quad k = 1, 3, 5, \dots$$

Put $\eta_k := S_{n_{k+1}} - S_{n_k}$. The partial sums of $\sum_{k \geq 1} \eta_k$ are bounded almost surely.

On a possibly larger probability space, let $(r_n)_{n \geq 1}$ be a real Rademacher sequence independent of $(\xi_n)_{n \geq 1}$. By Proposition 6.4.9, the partial sums of $\sum_{k \geq 1} \eta_k$ are bounded in probability, and because $(\eta_n)_{n \geq 1}$ and $(r_n \eta_n)_{n \geq 1}$ are identically distributed the same is true for the partial sums of $\sum_{k \geq 1} r_k \eta_k$. Another application of Proposition 6.4.9 shows that the partial sums of this series are bounded almost surely.

We may assume that the sequences $(\eta_k)_{k \geq 1}$ and $(r_k)_{k \geq 1}$ are defined on two separate probability spaces, say on Ω_η and Ω_r . By Fubini's theorem, for almost all $\omega \in \Omega_\eta$ the partial sums of $\sum_{k \geq 1} r_k \eta_k(\omega)$ are bounded almost surely on Ω_r . By (2), $\lim_{k \rightarrow \infty} \eta_k(\omega) = 0$ for almost all $\omega \in \Omega_\eta$. This implies that $\lim_{k \rightarrow \infty} \eta_k = \lim_{k \rightarrow \infty} S_{n_{k+1}} - S_{n_k} = 0$ in probability. This contradiction concludes the proof. \square

Remark 6.4.11. The theorem remains true if we replace 'real-symmetric' by 'symmetric' in condition (1). In fact, denoting this modified condition (1)', we have the implications (1)' \Rightarrow (2)' \Rightarrow (3) \Rightarrow (2) \Rightarrow (1) \Rightarrow (1)', where (2)' is obtained from (2) by replacing the real Rademachers r_n by Rademachers ε_n .

Corollary 6.4.12. *Let $1 \leq p < \infty$ and let X be a Banach space not containing a closed subspace isomorphic to c_0 . If $(\xi_n)_{n \geq 1}$ is a sequence of independent real-symmetric X -valued random variables whose partial sums $S_n = \sum_{j=1}^n \xi_j$ are bounded in $L^p(\Omega; X)$, then the sequence $(S_n)_{n \geq 1}$ converges both in $L^p(\Omega; X)$ and almost everywhere.*

Proof. By Chebyshev's inequality, the sequence $(S_n)_{n \geq 1}$ is bounded in probability, hence bounded almost surely by Proposition 6.4.9. The Hoffmann-Jørgensen-Kwapień Theorem 6.4.10 now implies that $(S_n)_{n \geq 1}$ converges to some random variable S almost everywhere. Moreover, by the Itô-Nisio Theorem 6.4.1, the boundedness of $(S_n)_{n \geq 1}$ in $L^p(\Omega; X)$ implies its convergence in $L^p(\Omega; X)$. \square

6.5 Comparison of random sums and trigonometric sums

The comparison result of this section has a somewhat different flavour than the ones we have encountered so far. It establishes a comparison between the

complex Rademacher sums $\sum_{j=1}^N \varepsilon_j x_j$ and the lacunary trigonometric sums $\sum_{j=1}^N e_{2^j} x_j$, where

$$e_k(t) := e^{2\pi i k t}$$

is the k -th trigonometric monomial on the unit interval $\mathbb{T} := [0, 1)$. While each individual e_k is clearly distributed like a complex Rademacher variable, the trigonometric monomials are highly non-independent; indeed $e_k = (e_1)^k$, so they are all generated by the first one. Nevertheless, in analogy with the comparison results for other random sums, we have:

Theorem 6.5.1 (Pisier). *Let X be an arbitrary complex Banach space and let $p \in [1, \infty)$. Then*

$$\frac{1}{4} \left\| \sum_{j=1}^N \varepsilon_j x_j \right\|_{L^p(\Omega; X)} \leq \left\| \sum_{j=1}^N e_{2^j} x_j \right\|_{L^p(\mathbb{T}; X)} \leq 4 \left\| \sum_{j=1}^N \varepsilon_j x_j \right\|_{L^p(\Omega; X)}$$

for all $N \in \mathbb{Z}_+$ and all $x_1, \dots, x_N \in X$.

This two-sided inequality depends on two facts: first, that the exponential sequence $\{2^j\}_{j=1}^\infty$ is a so-called *Sidon set* (Proposition 6.5.3), and second, that all Sidon sets satisfy such an estimate (Theorem 6.5.5). We start with the definition.

Definition 6.5.2 (Sidon sets). *A subset $A \subseteq \mathbb{Z}$ is called a Sidon set if the following estimate holds uniformly over all finitely non-zero sequences $(c_\lambda)_{\lambda \in A}$ of complex numbers:*

$$\sum_{\lambda \in A} |c_\lambda| \leq C \left\| \sum_{\lambda \in A} c_\lambda e_\lambda \right\|_\infty.$$

The smallest admissible constant C is called the Sidon constant of A and is denoted by $S(A)$.

Basic examples of Sidon sets are provided by lacunary sequences. We say that a sequence $(\lambda_j)_{j=1}^\infty$ of positive numbers is A -lacunary if $\lambda_{j+1}/\lambda_j \geq A > 1$ for all j .

Proposition 6.5.3. *Every A -lacunary sequence A of positive integers is a Sidon set with $S(A) \leq 2 \lceil \log_A \max\{3, (2A - 1)/(A - 1)\} \rceil$. In particular, $S(\{2^j\}_{j=1}^\infty) \leq 4$.*

The key technical tool for the proof is provided by the following lemma.

Lemma 6.5.4. *Let $A > 1$ and $B \geq \max\{3, (2A - 1)/(A - 1)\}$, and let $(\mu_j)_{j=1}^\infty$ be a B -lacunary sequence of positive integers and $\xi_j \in \mathbb{T}$. Then the Riesz product*

$$R(x) := \prod_{j=1}^N [1 + \cos(2\pi(\mu_j x + \xi_j))]$$

has Fourier coefficients $\widehat{R}(0) = 1$, $\widehat{R}(\pm\mu_j) = \frac{1}{2} e^{\pm 2\pi i \xi_j}$ for $j = 1, \dots, N$, and $\widehat{R}(k) \neq 0$ only if $k = 0$ or $\mu_j/A < |k| < A\mu_j$ for one of these j .

Proof. Expanding the product, we have

$$\begin{aligned}
R(x) &= \prod_{j=1}^N \left[1 + \frac{1}{2} \{ e^{2\pi i(\mu_j x + \xi_j)} + e^{-2\pi i(\mu_j x + \xi_j)} \} \right] \\
&= \sum_{\alpha \in \{-1, 0, +1\}^N} 2^{-|\alpha|} \exp \left(2\pi i \sum_{j=1}^N \alpha_j (\mu_j x + \xi_j) \right) \quad (6.19) \\
&= \sum_{k \in \mathbb{Z}} e_k(x) \sum_{\substack{\alpha \in \{-1, 0, +1\}^N \\ \alpha \cdot \mu = k}} 2^{-|\alpha|} e^{2\pi i \alpha \cdot \xi},
\end{aligned}$$

where $\mu := (\mu_1, \dots, \mu_N) \in \mathbb{Z}_+^N$, $\xi := (\xi_1, \dots, \xi_N) \in \mathbb{T}^N$, and $|\alpha| := \sum_{j=1}^N |\alpha_j|$.

We next check that the equation $\alpha \cdot \mu = k$ has at most one solution for a given k , and any solution at all only when $k = 0$ or $\mu_j/A < |k| < A\mu_j$ for some μ_j . In fact, we have

$$\alpha \cdot \mu = \sum_{j=1}^N \alpha_j \mu_j = \pm \mu_{j_1} \pm \mu_{j_2} \pm \dots, \quad \mu_{j_\ell} \geq B \mu_{j_{\ell+1}}.$$

Suppose that two such sums are equal, $\alpha \cdot \mu = \alpha' \cdot \mu$. If $\mu_{j'_1} < \mu_{j_1}$ (including formally the case that $\alpha \neq 0 = \alpha'$), then the sum of all the terms other than μ_{j_1} on both sides of the equation is strictly less than

$$2 \sum_{\ell=1}^{\infty} B^{-\ell} \mu_{j_1} = \frac{2}{B-1} \mu_{j_1} \leq \mu_{j_1}$$

since $B \geq 3$. This lead to the contradiction $\mu_{j_1} = |\alpha_{j_1} \mu_{j_1}| = |\alpha \cdot \mu - (\alpha \cdot \mu - \alpha_{j_1} \mu_{j_1})| = |\alpha' \cdot \mu - (\alpha \cdot \mu - \alpha_{j_1} \mu_{j_1})| < \mu_{j_1}$.

If $\mu_{j_1} = \mu_{j'_1}$ and $\alpha_{j_1} \neq \alpha_{j'_1}$, then the rest of the terms have the same upper bound as above, and we arrive at the even stronger contradiction that $2\mu_{j_1} = |\alpha_{j_1} \mu_{j_1} - \alpha_{j'_1} \mu_{j'_1}| = |\alpha \cdot \mu - (\alpha \cdot \mu - \alpha_{j_1} \mu_{j_1}) - \alpha' \cdot \mu + (\alpha' \cdot \mu - \alpha_{j'_1} \mu_{j'_1})| = |-(\alpha \cdot \mu - \alpha_{j_1} \mu_{j_1}) + (\alpha' \cdot \mu - \alpha_{j'_1} \mu_{j'_1})| < \mu_{j_1}$. Thus it must be that $\mu_{j_1} = \mu_{j'_1}$ and $\alpha_{j_1} = \alpha_{j'_1}$, but then we may cancel these terms from both sides and we are left with the equality of similar shorter sums. By induction it follows that $\alpha = \alpha'$. In particular, we have that $\alpha = 0$ is the unique solution of $\alpha \cdot \mu = 0$, while $\alpha = \pm u_j$ (here u_j is the standard basis in \mathbb{R}^N) is the unique solution of $\alpha \cdot \mu = \pm \mu_j$, and then it is easy to check the values of the corresponding Fourier coefficients from (6.19).

Finally, if $k = \alpha \cdot \mu \neq 0$, then $|k|$ lies strictly between

$$\mu_{j_1} \left(1 - \sum_{\ell=1}^{\infty} B^{-\ell} \right) = \mu_{j_1} \frac{B-2}{B-1} \quad \text{and} \quad \mu_{j_1} \sum_{\ell=0}^{\infty} B^{-\ell} = \mu_{j_1} \frac{B}{B-1},$$

and $B \geq (2A-1)/(A-1) > A/(A-1)$ implies that $\mu_{j_1}/A < |k| < A\mu_{j_1}$. \square

Proof of Proposition 6.5.3. Let $A = (\lambda_j)_{j=1}^\infty$ be an A -lacunary sequence. It is immediate that each subsequence $A_s := (\lambda_{jr-s})_{j=1}^\infty$, $s = 0, \dots, r-1$, is A^r -lacunary. Let r be the smallest positive integer such that $B := A^r \geq \max\{3, (2A-1)/(A-1)\}$. Hence Lemma 6.5.4 applies to the Riesz products

$$R_s(x) := \prod_{j=1}^N [1 + \cos(2\pi(\lambda_{jr-s}x + \xi_{jr-s}))].$$

It follows that their sum $R := \sum_{s=0}^{r-1} R_s$ has Fourier coefficients

$$\widehat{R}(0) = r, \quad \widehat{R}(\pm\lambda_j) = \frac{1}{2}e^{\pm 2\pi i \xi_j} \quad j = 1, \dots, rN;$$

note in particular that $\widehat{R}_s(\pm\mu_{j'r-s'}) = 0$ for $s \neq s'$ since $\mu_{j'r-s'}/\mu_{jr-s} \notin (A^{-1}, A)$ for any j .

Thus, for a trigonometric polynomial $f = \sum_{\lambda \in A} c_\lambda e_\lambda$,

$$\int_{\mathbb{T}} R(x)f(x) dx = \sum_{k \in \mathbb{Z}} \widehat{R}(-k)\widehat{f}(k) = \frac{1}{2} \sum_{j=1}^{rN} e^{-2\pi i \xi_j} c_{\lambda_j} = \frac{1}{2} \sum_{j=1}^{rN} |c_{\lambda_j}|,$$

when we make the obvious choice of ξ_j in the definition of the Riesz product R_s . On the other hand, we have

$$\left| \int_{\mathbb{T}} R(x)f(x) dx \right| \leq \|R\|_1 \|f\|_\infty = r \left\| \sum_{\lambda \in A} c_\lambda e_\lambda \right\|_\infty,$$

since the non-negative function R satisfies $\|R\|_1 = \int_{\mathbb{T}} R(x) dx = \widehat{R}(0) = r$.

Letting $N \rightarrow \infty$, we have shown that

$$\sum_{\lambda \in A} |c_\lambda| \leq 2r \left\| \sum_{\lambda \in A} c_\lambda e_\lambda \right\|_\infty, \quad r = \left\lceil \log_A \max \left\{ 3, \frac{2A-1}{A-1} \right\} \right\rceil.$$

□

The general comparison result involving Sidon sets is the following. Clearly Theorem 6.5.1 is a direct consequence of Theorem 6.5.5 and Proposition 6.5.3.

Theorem 6.5.5 (Pisier). *Let X be an arbitrary Banach space and $p \in [1, \infty)$. If $A \subseteq \mathbb{Z}$ is a Sidon set, then*

$$\frac{1}{S(A)} \left\| \sum_{\lambda \in A} \varepsilon_\lambda x_\lambda \right\|_{L^p(\Omega; X)} \leq \left\| \sum_{\lambda \in A} e_\lambda x_\lambda \right\|_{L^p(\mathbb{T}; X)} \leq S(A) \left\| \sum_{\lambda \in A} \varepsilon_\lambda x_\lambda \right\|_{L^p(\Omega; X)}$$

for all finitely non-zero sequences of $x_\lambda \in X$.

Proof. It follows at once from the definition of a Sidon set that the following functionals are uniformly bounded with norm at most $S(A)$, as the complex signs ϵ_λ vary arbitrarily on the unit circle:

$$f = \sum_{\lambda \in A} c_\lambda e_\lambda \mapsto \sum_{\lambda \in A} \epsilon_\lambda c_\lambda,$$

where the domain is the subspace of $C(\mathbb{T})$ of all finite linear combinations of the e_λ , $\lambda \in A$. We now consider one such functional for a fixed choice of complex signs ϵ_λ . By the Hahn–Banach theorem, this functional has a bounded extension to all of $C(\mathbb{T})$; thus there exists a regular Borel measure μ on \mathbb{T} , of total variation $\|\mu\| \leq S(A)$, such that

$$\int_{\mathbb{T}} e_\lambda d\mu = \epsilon_\lambda, \quad \lambda \in A.$$

Let $\tilde{\mu}$ be its reflection, $\tilde{\mu}(A) := \mu(-A)$. Then, for any finite sum $f = \sum_{\lambda \in A} \epsilon_\lambda x_\lambda$,

$$\begin{aligned} f * \tilde{\mu}(t) &= \int_{\mathbb{T}} f(t-s) d\tilde{\mu}(s) = \int_{\mathbb{T}} f(t+s) d\mu(s) \\ &= \sum_{\lambda \in A} \epsilon_\lambda(t) x_\lambda \int_{\mathbb{T}} e_\lambda(s) d\mu(s) = \sum_{\lambda \in A} \epsilon_\lambda \epsilon_\lambda(t) x_\lambda, \end{aligned}$$

and thus

$$\begin{aligned} \left\| \sum_{\lambda \in A} \epsilon_\lambda e_\lambda x_\lambda \right\|_{L^p(\mathbb{T}; X)} &= \|f * \tilde{\mu}\|_{L^p(\mathbb{T}; X)} \\ &\leq \|f\|_{L^p(\mathbb{T}; X)} \|\tilde{\mu}\| \leq S(A) \left\| \sum_{\lambda \in A} e_\lambda x_\lambda \right\|_{L^p(\mathbb{T}; X)} \end{aligned}$$

for all $p \in [1, \infty]$. Applying this with $\bar{\epsilon}_\lambda x_\lambda$ in place of x_λ , and noting that the conjugate coefficients $\bar{\epsilon}_\lambda$ are as arbitrary as the original ϵ_λ , we obtain a similar estimate to the other direction. For $p \in [1, \infty)$, we may take the inequality to the power p , substitute random signs ε_j in place of ϵ_j , and integrate over the underlying probability space. The proof is concluded by using the contraction principle, which shows that

$$\left\| \sum_{\lambda \in A} \varepsilon_\lambda e_\lambda x_\lambda \right\|_{L^p(\Omega \times \mathbb{T}; X)} = \left\| \sum_{\lambda \in A} \varepsilon_\lambda x_\lambda \right\|_{L^p(\Omega; X)}.$$

□

6.6 Notes

Section 6.1

General references to probability in Banach spaces are [Diestel, Jarchow, and Tonge \[1995\]](#), [Kahane \[1985\]](#), [Kwapień and Woyczyński \[2002\]](#), [Ledoux and Talagrand \[1991\]](#), [Vakhania, Tarieladze, and Chobanyan \[1987\]](#).

Kahane's contraction principle in its basic version, Theorem 6.1.13(i), is from Kahane [1985], while the variant in Theorem 6.1.13(ii) is from Pietsch and Wenzel [1998, 3.5.4]. We refer to Section 3.2.b for the heart of the argument in the case of Rademacher sequences, from which the present extension to symmetric random variables was straightforward.

Lévy's inequality (Proposition 6.1.12) is classical and the proof presented here can be found in many textbooks. It has various refinements which can be found in the general references already cited.

A different proof of the covariance domination (Theorem 6.1.25) can be found in Albiac and Kalton [2006, Chapter 7].

Tail estimates related to the contraction principle

The following tail estimate is a variation on the contraction principle:

Theorem 6.6.1 (Kahane's contraction principle, tail estimate). *Let $(\xi_n)_{n=1}^N$ be a sequence of independent and symmetric random variables with values in a Banach space X . Then for all scalar sequences $(a_n)_{n=1}^N$ we have*

$$\mathbb{P}\left(\left\|\sum_{n=1}^N a_n \xi_n\right\| > t\right) \leq 2\mathbb{P}\left(\max_{1 \leq n \leq N} |a_n| \left\|\sum_{n=1}^N \xi_n\right\| > t\right).$$

Proof. By symmetry it suffices to consider the case of non-negative scalars $(a_n)_{n=1}^N$, and by renumbering and scaling we may also assume that $0 \leq a_N \leq \dots \leq a_1 = 1$. Let $a_{N+1} = 0$. Writing $S_n = \sum_{k=1}^n \xi_k$, summation by parts gives

$$\sum_{n=1}^N a_n \xi_n = \sum_{n=1}^N a_n (S_n - S_{n-1}) = \sum_{n=1}^N (a_n - a_{n+1}) S_n.$$

Since $\sum_{n=1}^N (a_n - a_{n+1}) = a_1 = 1$,

$$\left\{\sum_{n=1}^N (a_n - a_{n+1}) S_n > t\right\} \subseteq \left\{\max_{1 \leq n \leq N} \|S_n\| > t\right\}.$$

Therefore, Lévy's inequality (Proposition 6.1.12) implies the required result. \square

A thorough presentation of tail estimates for sums of independent random variables can be found in De la Peña and Giné [1999].

Section 6.2

Theorem 6.2.2 and Lemma 6.2.3 go back to Bonami [1970]. About the same time, hypercontractivity for Gaussian random variables was proved by Nelson [1973], improving an earlier result of Nelson [1966]. Proofs based on the

logarithmic Sobolev inequality were given subsequently by Gross [1975]. The proof of Lemma 6.2.3 presented here is from Beckner [1975] and the induction argument used in our proof of Theorem 6.2.2 is from Kwapien and Szulga [1991]. Hypercontractivity estimates such as the one of Theorem 6.2.2 exist both in the analytic and probabilistic framework. Accounts of the history of the subject are given in Davies, Gross, and Simon [1992], Bakry, Gentil, and Ledoux [2014], Simon [2015]. In the vector-valued case, Theorem 6.2.2 is due to Borell [1979]. Non-symmetric versions of these results have been obtained in Oleszkiewicz [2003], Wolff [2007]. A further discussion on a complex version of Theorem 6.2.2 can be found in Theorem 6.6.5 below.

The Kahane–Khintchine inequality (Theorem 6.2.4) is Kahane’s vector-valued extension of the classical scalar-valued version due to Khintchine [1923]. A tail estimate that captures the essence of this inequality is already contained in Kahane [1964]; that this implies the version of the estimate as in Theorem 6.2.4 was pointed out in Kahane [1985]. Other proofs based on estimates of tail probabilities can be found in Ledoux and Talagrand [1991] and Oleszkiewicz [2014]. The proof presented here based on the hypercontractivity estimates can be found, e.g., in Kwapien and Woyczyński [2002] and De la Peña and Giné [1999]. A proof via the martingale John–Nirenberg inequality was given in Chapter 3.

The constant in the Kahane–Khintchine inequalities

We remind the reader of the notation employed for the optimal constants in the Kahane–Khintchine inequalities explained at the beginning of Section 6.2. It will be used freely in the discussion that follows.

The optimal constant in the Kahane–Khintchine inequalities for real Rademacher sums is known in a few instances. Szarek [1976] proved that

$$\kappa_{2,1,\mathbb{R}} = \sqrt{2},$$

thereby resolving an old conjecture of Littlewood. The optimal constants $\kappa_{q,2,\mathbb{R}}$ have been obtained by Whittle [1960] for all $q \geq 2$, and independently by Stečín [1961] for integers $q \geq 2$. The problem was settled by Haagerup [1981], who found the best constants $\kappa_{p,2,\mathbb{R}}$ and $\kappa_{2,p,\mathbb{R}}$ for all $0 < p < \infty$. As a special case of his results one has

$$\kappa_{q,2,\mathbb{R}} = \|\gamma\|_q \quad \text{for } q \geq 2,$$

where γ is standard real Gaussian variable. König and Kwapien [2001] and Baernstein and Culverhouse [2002] extended several of the above results to more general rotationally invariant random variables in \mathbb{R}^d , and a case which was left open for the complex Rademachers was eventually solved in König [2014]. Similar results were obtained by Latała and Oleszkiewicz [1995a] for random variables which are uniformly distributed on $[0, 1]$. For even exponents, Nayar and Oleszkiewicz [2012] extended several of the above results to

ultra sub-Gaussian random vectors (this class includes random variables which are uniformly distributed on a ball or sphere centred at zero). In particular, it follows from their results that

$$\kappa_{q,p,\mathbb{R}} = \frac{\|\gamma\|_q}{\|\gamma\|_p} \quad \text{for } p, q \in 2\mathbb{N}, \quad q \geq p.$$

Eskenazis, Nayar, and Tkocz [2016] obtained optimal constants for Gaussian mixtures which are random variables of the form $\gamma\xi$, where γ is a standard Gaussian random variable and ξ is an independent positive random variable which has finite p -moments for all $p < \infty$.

Almost 20 years after Szarek [1976]'s proof that $\kappa_{2,1,\mathbb{R}} = \sqrt{2}$, Latała and Oleszkiewicz [1994] found a very short proof of the more general fact that

$$\kappa_{2,1,X}^{\mathbb{R}} = \kappa_{2,1}^{\mathbb{R}} = \sqrt{2}$$

holds for any Banach space X . An alternative approach can be found in De la Peña and Giné [1999, Section 1.3] and Latała and Oleszkiewicz [1995b], where the following optimal constants are obtained:

$$\begin{aligned} \kappa_{q,p,X}^{\mathbb{R}} &= \kappa_{q,p}^{\mathbb{R}} = 2^{1/p-1/q} \quad \text{for } q \in (0, 2] \text{ and } p \in (0, 1] \text{ and } q > p, \\ \kappa_{4,2,X}^{\mathbb{R}} &= \kappa_{4,2}^{\mathbb{R}} = 3^{1/4}. \end{aligned}$$

These results provide support for the following conjecture:

Conjecture 6.6.2 (Kwapień). For any Banach space X and all $0 < p \leq q < \infty$,

$$\kappa_{q,p,X}^{\mathbb{R}} = \kappa_{q,p}^{\mathbb{R}} = \kappa_{q,p;\mathbb{R}}.$$

For Hilbert spaces this is indeed true. In fact, Fubini's theorem and Minkowski's inequality imply the identity $\kappa_{q,p,L^q}^{\mathbb{R}} = \kappa_{q,p,\mathbb{R}}$, and the statement in the conjecture for Hilbert spaces follows from this since every Hilbert space is isometric to a closed subspace of an L^q -space. In Oleszkiewicz [2014] it has been shown that $\sup_{1 \leq p \leq q} \kappa_{q,p,X}^{\mathbb{R}} / \kappa_{q,p,\mathbb{R}} \rightarrow 1$ as $q \rightarrow \infty$, providing further evidence for the conjecture.

Let $(g_n)_{n=1}^N$ be a real Gaussian sequence. For real scalars c_1, \dots, c_n , the Gaussian sum $\sum_{n=1}^N c_n g_n$ is a real Gaussian random variable with variance $\sum_{n=1}^N c_n^2$; from this one easily derives that

$$\kappa_{q,p,\mathbb{R}}^{\gamma} = \frac{\|g\|_q}{\|\gamma\|_p} \quad \text{for } p, q \in (0, \infty),$$

where g is a standard real Gaussian variable. A deep result of Latała and Oleszkiewicz [1999] states that for any Banach space X and all $0 < p \leq q < \infty$ one has

$$\kappa_{q,p,X}^{\gamma,\mathbb{R}} = \kappa_{q,p}^{\gamma,\mathbb{R}} = \kappa_{q,p,\mathbb{R}}^{\gamma} = \frac{\|\gamma\|_q}{\|\gamma\|_p}.$$

Hypercontractivity and Kahane–Khintchine inequalities for complex Rademachers

In Lemma 6.2.3 (and hence in 6.2.2), only real Rademacher sequences are considered. The difficulty in the complex case is that the σ -algebra generated by a complex Rademacher random variable is not finite. For this reason we had to deduce the complex case of Theorem 6.2.4 from the real case via Proposition 6.1.19. There is a natural complex analogue of Lemma 6.2.3, namely, a hypercontractivity estimate for the Poisson semigroup.

For $n \in \mathbb{Z}$, let $e_n(\theta) := e^{2\pi i n \theta}$ be the trigonometric functions on the torus $\mathbb{T} = [0, 1]$. The next result is due to Weissler [1980] (see also Beckner [1995], Janson [1983]).

Theorem 6.6.3 (Hypercontractivity of the Poisson semigroup). *Let X be a Banach space and $1 < p \leq q < \infty$. The Poisson semigroup $(P(t))_{t \geq 0}$ on $L^p(\mathbb{T})$, defined by*

$$P(t)f = \sum_{n \in \mathbb{Z}} a_n e^{-t|n|} e_n \quad \text{for } f = \sum_{n \in \mathbb{Z}} a_n e_n \in L^p(\mathbb{T}),$$

satisfies

$$\|P(t)\|_{L^p \rightarrow L^q} \leq 1$$

if and only if

$$e^{-t} \leq \sqrt{\frac{p-1}{q-1}}.$$

The proof of Theorem 6.6.3 is based on a logarithmic Sobolev inequality on the torus. Since the Poisson semigroup is positive, the above result extends to the Banach space-valued setting by Theorem 2.1.3. An interesting consequence is the following complex variant of Lemma 6.2.3.

Corollary 6.6.4. *Let ε be a complex Rademacher random variable and X a complex Banach space. Then for all $x, y \in X$ and $0 < p < q < \infty$,*

$$\|x + \theta \varepsilon y\|_{L^q(\Omega; X)} \leq \|x + \varepsilon y\|_{L^p(\Omega; X)} \quad \text{for all } 0 \leq \theta \leq \sqrt{\frac{p}{q}}.$$

Observe that $\sqrt{\frac{p}{q}} \leq \sqrt{\frac{p-1}{q-1}}$, and therefore the estimate in the case of complex Rademachers is better than the one for real Rademachers. In the proof we use an argument due to Janson, as presented in Weissler [1980].

Proof. The proof uses some elementary facts from the theory of sub-harmonic functions. Let $\mathbb{D} \subseteq \mathbb{C}$ denote the open unit disk. Fix $x, y \in X$ and define $u : \mathbb{D} \rightarrow [0, \infty)$ by $u(z) = \|x + zy\|^{1/n}$, where $n \geq 1$ is fixed for the moment. Since

$$u(z) = \sup_{\|x^*\| \leq 1} |\langle x + zy, x^* \rangle|^{1/n},$$

u is sub-harmonic by [Rudin \[1987, Theorem 17.3\]](#). Define the harmonic function $v : \mathbb{D} \rightarrow \mathbb{C}$ by

$$v(re^{2\pi i\theta}) := (P(t)[u(e^{2\pi i\cdot})])(\theta), \quad \theta \in [0, 1], \quad r = e^{-t}, \quad t \geq 0.$$

Since $u|_{\partial\mathbb{D}} = v|_{\partial\mathbb{D}}$, from [Rudin \[1987, Theorem 17.4\]](#) it follows that $u \leq v$ on \mathbb{D} .

Fix $r = e^{-t} \in [0, \sqrt{\frac{p}{q}}]$ and choose $n \geq 1$ so large that $r \leq \sqrt{\frac{np-1}{nq-1}}$. Since $\theta \mapsto e^{2\pi i\theta}$ has the same distribution as ε , we have

$$\|x + r\varepsilon y\|_{L^q(\Omega; X)} = \left(\int_0^1 \|x + re^{2\pi i\theta} y\|^q d\theta \right)^{1/q} = \left(\int_0^1 |u(re^{2\pi i\theta})|^{nq} d\theta \right)^{1/q},$$

and the same hold if we replace q and r by p and 1 respectively. Combining the above observations with [Theorem 6.6.3](#) we obtain

$$\begin{aligned} \|x + r\varepsilon y\|_{L^q(\Omega; X)} &= \left(\int_0^1 |u(re^{2\pi i\theta})|^{nq} d\theta \right)^{1/q} \leq \left(\int_0^1 |v(re^{2\pi i\theta})|^{nq} d\theta \right)^{1/q} \\ &= \|P(t)u(e^{2\pi i\cdot})\|_{nq}^n \leq \|u(e^{2\pi i\cdot})\|_{np}^n = \|x + \varepsilon y\|_{L^p(\Omega; X)}. \end{aligned}$$

This proves the result for $0 \leq r < \sqrt{\frac{p}{q}}$. The case $r = \sqrt{\frac{p}{q}}$ follows by a limiting argument. \square

With the help of this result, [Theorem 6.2.2](#) can be extended to the complex case. This leads to the following complex version of [Theorem 6.2.4](#):

Theorem 6.6.5. *Let $(\varepsilon_n)_{n \geq 1}$ be a complex Rademacher sequence. Then for all $0 < p < q < \infty$ and all sequences $(x_n)_{n=1}^N$ in X ,*

$$\left\| \sum_{n=1}^N \varepsilon_n x_n \right\|_{L^q(\Omega; X)} \leq \sqrt{\frac{q}{p}} \left\| \sum_{n=1}^N \varepsilon_n x_n \right\|_{L^p(\Omega; X)},$$

Section 6.3

A good source for the material in this section is [Pisier \[1989\]](#).

Section 6.4

The Itô–Nisio [Theorem 6.4.1](#) is from [Itô and Nisio \[1968\]](#). Further equivalences to the four listed in the text can be found, for example, in [Kwapień and Woyczyński \[2002\]](#). A martingale version has already been presented in [Theorem 3.3.14](#).

The Hoffmann–Jørgensen–Kwapień [Theorem 6.4.10](#) is due to [Hoffmann–Jørgensen \[1974\]](#) and [Kwapień \[1974\]](#). In [Hoffmann–Jørgensen \[1974\]](#) it is proved that if X is a Banach space and (Ω, \mathbb{P}) is a probability space rich

enough to support a Rademacher sequence, then the conditions of Theorem 6.4.10 are equivalent to the non-containment of c_0 in $L^p(\Omega; X)$ for some (or equivalently, all) $1 \leq p < \infty$, and it was conjectured that the latter is equivalent to the non-containment of c_0 in X . This is condition (3) of Theorem 6.4.10. In the same issue of *Studia Mathematica*, Kwapien [1974] settled this conjecture in the affirmative.

Section 6.5

Theorems 6.5.1 and 6.5.5 on the comparison of Rademacher and trigonometric sums are due to Pisier [1978a]. The related fact that lacunary sequences are Sidon sets (Proposition 6.5.3) is classical. We have adapted an argument from Zygmund [2002, Theorem VI.6.1].

Type, cotype, and related properties

In this chapter we will see that some of the deeper properties of Rademacher sums and Gaussian sums are intimately linked with the geometry of the Banach space in which they live. In one direction, important geometric notions such as type, cotype, and K -convexity are defined through *a priori* assumptions on the behaviour of random sums. In the other direction, the presence of such properties often significantly improves the behaviour of random sums. For example, in every Banach space with finite cotype, L^p -norms of Rademacher sums and Gaussian sums are equivalent.

After discussing the definitions and basic properties of type and cotype, we undertake a study of so-called summing operators. Their importance to the topic at hand largely stems from the fact that if X has cotype q , then every bounded linear operator $T : C(K) \rightarrow X$, where K is a compact Hausdorff space, is $(q, 1)$ -summing. This fundamental result, together with the factorisation theorem of Pisier proved in Section 7.2 is at the basis of some subtle comparison results in the same section, which also includes the comparison of Rademacher sums and Gaussian sums for spaces of finite cotype. These results will play an important role in later chapters.

In Section 7.3, we provide Kwapien's isomorphic characterisation of Hilbert spaces in terms of type and cotype 2, and present the geometric characterisations for non-trivial type and cotype due to Maurey and Pisier. The latter allows us to compare several of the earlier encountered Banach space properties with type and cotype. For example, UMD Banach spaces are shown to have non-trivial type and finite cotype.

The dual of every Banach space X with type p has cotype q , with $\frac{1}{p} + \frac{1}{q} = 1$, but the converse fails. The symmetry between these notions (and indeed, between several other notions as well) is restored by introducing an *a priori* boundedness assumption, called K -convexity, on the Rademacher projections in X . Banach spaces with this property are the object of study in Section 7.4 and often play a role when duality arguments are applied for random

sums. Among other things we will prove Pisier's theorem on the equivalence of K -convexity and non-trivial type.

In the final section of this chapter we study various types of estimates for Banach space-valued double random sums. In contrast to the situation for random sums, the contraction principle generally fails for double random sums. For a given Banach space, the validity of various kinds of contraction principles becomes a useful property that has far-reaching consequences, some of which will be explored in later chapters.

7.1 Type and cotype

In this first section, we introduce the definitions and basic properties of type and cotype and the main examples of spaces satisfying one or the other of these conditions. Among the deeper results is the König–Tzafriri Theorem 7.1.14, which deduces cotype from type with quantitative estimates for the relevant constants. The section concludes with a far reaching extremality property of Gaussian sequence in spaces with the best possible type or cotype 2.

7.1.a Definitions and basic properties

Unless stated otherwise, $(\varepsilon_n)_{n \geq 1}$ will always denote a Rademacher sequence defined on some probability space (Ω, \mathbb{P}) . Recall the standing assumption that Rademacher sequences are real (respectively, complex) when we work over the real (respectively, complex) scalar field.

Definition 7.1.1 (Type and cotype). *Let X be a Banach space, let $p \in [1, 2]$ and $q \in [2, \infty]$.*

- (1) *The space X is said to have type p if there exists a constant $\tau \geq 0$ such that for all finite sequences x_1, \dots, x_N in X we have*

$$\left(\mathbb{E} \left\| \sum_{n=1}^N \varepsilon_n x_n \right\|^p \right)^{1/p} \leq \tau \left(\sum_{n=1}^N \|x_n\|^p \right)^{1/p}.$$

- (2) *The space X is said to have cotype q if there exists a constant $c \geq 0$ such that for all finite sequences x_1, \dots, x_N in X we have*

$$\left(\sum_{n=1}^N \|x_n\|^q \right)^{1/q} \leq c \left(\mathbb{E} \left\| \sum_{n=1}^N \varepsilon_n x_n \right\|^q \right)^{1/q},$$

with the usual modification for $q = \infty$.

We denote by $\tau_{p,X}$ and $c_{q,X}$ the least admissible constants in (1) and (2) and refer to them as the *type p constant* and *cotype q constant* of X , respectively.

From the case $N = 1$ we see that $\tau_{p,X} \geq 1$ and $c_{q,X} \geq 1$. By the Kahane–Khintchine inequalities, the exponents (with the exception of $q = \infty$) in the Rademacher sums in (1) and (2) could be replaced by any exponent $r \in [1, \infty)$. This leads to the same properties, but with different constants.

To check that the ensemble of spaces considered in Definition 7.1.1 is non-void, we immediately provide:

Example 7.1.2. Every Hilbert space H has type 2 and cotype 2, with constants $\tau_{2,H} = 1$ and $c_{2,H} = 1$. Indeed, for all $h_1, \dots, h_N \in H$ we have

$$\begin{aligned} \mathbb{E} \left\| \sum_{n=1}^N \varepsilon_n h_n \right\|^2 &= \mathbb{E} \left(\sum_{n=1}^N \varepsilon_n h_n \middle| \sum_{n=1}^N \varepsilon_n h_n \right) = \mathbb{E} \sum_{n=1}^N \sum_{m=1}^N \varepsilon_n \bar{\varepsilon}_m (h_n | h_m) \\ &= \sum_{n=1}^N \sum_{m=1}^N \mathbb{E}(\varepsilon_n \bar{\varepsilon}_m)(h_n | h_m) = \sum_{n=1}^N (h_n | h_n) = \sum_{n=1}^N \|h_n\|^2. \end{aligned}$$

This result can be interpreted as a generalisation of the parallelogram law. In Section 7.3.a we show that up to isomorphism, Hilbert spaces are the only Banach spaces with both type 2 and cotype 2.

It is easy to check that the inequalities defining type and cotype cannot be satisfied for any $p > 2$ and $q < 2$, respectively, even in one-dimensional spaces X . This explains the restrictions imposed on these numbers.

By the triangle inequality, every Banach space X has type 1, with constant $\tau_{1,X} = 1$. Likewise, the inequalities

$$\sup_{n \geq 1} \|x_n\| \leq \left\| \sum_{n=1}^N \varepsilon_n x_n \right\|_{L^1(\Omega; X)} \leq \left\| \sum_{n=1}^N \varepsilon_n x_n \right\|_{L^\infty(\Omega; X)}$$

show that every Banach space has cotype ∞ , with constant $c_{\infty,X} = 1$. We say that X has *non-trivial type* if X has type p for some $p \in (1, 2]$, and *finite cotype* if it has cotype q for some $q \in [2, \infty)$.

From the fact that the sequence space norm $\|\cdot\|_{\ell_N^t(X)}$ is decreasing and the probability space norm $\|\cdot\|_{L^t(\Omega; X)}$ is increasing in $t \in [1, \infty)$, it follows that if X has type p (cotype q), then it also has type u for all $u \in [1, p]$ (cotype v for all $v \in [q, \infty)$) and $\tau_{u,X} \leq \tau_{p,X}$ ($c_{v,X} \leq c_{q,X}$). In particular, every Hilbert space is also an example of a space with type p and cotype q for every $p \in [1, 2]$ and $q \in [2, \infty)$.

The property of type is well-behaved under interpolation, as shown by the following proposition. This is not the case for cotype, and we refer to the Notes for further comments on this point. An interpolation result for cotype will be proved, for K -convex Banach spaces X , in Proposition 7.4.17. The relevant terminology on interpolation can be found in Appendix C.

Proposition 7.1.3. *Let (X_0, X_1) be an interpolation couple and assume X_i has type $p_i \in [1, 2]$ for $i = 1, 2$. Let $\theta \in (0, 1)$ and $p \in [1, 2]$ satisfy $\frac{1}{p} = \frac{1-\theta}{p_0} +$*

$\frac{\theta}{p_1}$. The complex interpolation space $X_\theta = [X_0, X_1]_\theta$ and the real interpolation spaces $X_{\theta, p_0, p_1} = (X_0, X_1)_{\theta, p_0, p_1}$ have type p , with constants

$$\begin{aligned}\tau_{p, X_\theta} &\leq \tau_{p_0, X_0}^{1-\theta} \tau_{p_1, X_1}^\theta, \\ \tau_{p, X_{\theta, p_0, p_1}} &\leq \tau_{p_0, X_0}^{1-\theta} \tau_{p_1, X_1}^\theta.\end{aligned}$$

Recall that $X_{\theta, p_0, p_1} = (X_0, X_1)_{\theta, p}$ with equivalent norms (see Appendix C.3.14).

Proof. Fix $N \geq 1$. The operators $T : \ell_N^{p_i}(X_i) \rightarrow L^{p_i}(X_i)$ given by $T(x_n)_{n=1}^N = \sum_{n=1}^N \varepsilon_n x_n$, are bounded with norm at most τ_{p_i, X_i} . As is shown in Theorem 2.2.6,

$$\begin{aligned}[\ell_N^{p_0}(X_0), \ell_N^{p_1}(X_1)]_\theta &= \ell_N^p(X_\theta), \\ [L^{p_0}(X_0), L^{p_1}(X_1)]_\theta &= L^p(X_\theta),\end{aligned}$$

and therefore by interpolation we find that $T : \ell_N^p(X_\theta) \rightarrow L^p(X_\theta)$ is bounded with norm $\|T\| \leq \tau_{p_0, X_0}^{1-\theta} \tau_{p_1, X_1}^\theta$. The proof for the real interpolation spaces follows the same lines, but uses Theorem 2.2.10. \square

There will be occasions where we wish to compare the type and cotype of a complex Banach space X and its realification $X_{\mathbb{R}}$. For a complex Banach space X we write $\tau_{p, X}^{\mathbb{R}}$ and $c_{q, X}^{\mathbb{R}}$ for the best constant in the definition of type p and cotype q while using real Rademacher random variables. Thus

$$\tau_{p, X}^{\mathbb{R}} = \tau_{p, X_{\mathbb{R}}}, \quad c_{q, X}^{\mathbb{R}} = c_{q, X_{\mathbb{R}}},$$

and by randomisation and Proposition 6.1.19,

$$\tau_{p, X} \leq \tau_{p, X}^{\mathbb{R}} \leq \frac{1}{2} \pi \tau_{p, X}, \quad c_{q, X} \leq c_{q, X}^{\mathbb{R}} \leq \frac{1}{2} \pi c_{q, X}. \quad (7.1)$$

7.1.b Basic examples

We shall next analyse the type and cotype properties of general L^r -spaces, the finite-dimensional sequence spaces ℓ_N^1 and ℓ_N^∞ , and the Schatten classes \mathcal{C}^r .

In the context of type and cotype of L^r -type spaces, it is often convenient to use type and cotype constants $\tau_{p, X; s}$ and $c_{q, X; s}$ with a secondary parameter s , where these are defined as the least admissible constants in the estimates

$$\begin{aligned}\left\| \sum_{n=1}^N \varepsilon_n x_n \right\|_{L^s(\Omega; X)} &\leq \tau_{p, X; s} \left(\sum_{n=1}^N \|x_n\|^p \right)^{1/p}, \\ \left(\sum_{n=1}^N \|x_n\|^q \right)^{1/q} &\leq c_{q, X; s} \left\| \sum_{n=1}^N \varepsilon_n x_n \right\|_{L^s(\Omega; X)}.\end{aligned}$$

One can immediately estimate the ratios $\tau_{p,X;s}/\tau_{p,X}$ and $c_{q,X;s}/c_{q,X}$ from above and below with the Kahane–Khintchine inequality.

In the next proposition and its corollary, (S, \mathcal{A}, μ) is an arbitrary measure space.

Proposition 7.1.4. *Let X be a Banach space, let $p \in [1, 2]$, $q \in [2, \infty]$, and $r \in [1, \infty)$.*

(1) *If X has type p , then $L^r(S; X)$ has type $p \wedge r$, with*

$$\tau_{p \wedge r, L^r(S; X); s} \leq \tau_{p, X; s}, \quad s \in [r, \infty).$$

(2) *If X has cotype q , then $L^r(S; X)$ has cotype $q \vee r$, with*

$$c_{q \vee r, L^r(S; X); t} \leq c_{q, X; t}, \quad t \in [1, r].$$

Proof. We will prove the result for type, the case of cotype being similar. If $r < p$ we may replace p by r and thereby assume that $1 \leq p \leq r \leq s$.

Fix $f_1, \dots, f_N \in L^r(S; X)$. In the remainder of the proof, without loss of generality we may assume that μ is σ -finite (replace S by the union of the sets $S_j = \{2^j \leq \max_{1 \leq n \leq N} \|f_n\| < 2^{j+1}\}$, each of which has finite μ -measure). Using Minkowski's inequality twice (Proposition 1.2.22) and the type p property,

$$\begin{aligned} \left\| \sum_{n=1}^N \varepsilon_n f_n \right\|_{L^s(\Omega; L^r(S; X))} &\leq \left\| \sum_{n=1}^N \varepsilon_n f_n \right\|_{L^r(S; L^s(\Omega; X))} \\ &\leq \tau_{p, X; s} \left\| (f_n)_{n=1}^N \right\|_{L^r(S; \ell^p(X))} \\ &\leq \tau_{p, X; s} \left\| (f_n)_{n=1}^N \right\|_{\ell^p(L^r(S; X))}. \end{aligned}$$

□

The usefulness of having these estimates with constant one is most evident in iterative considerations. As an immediate corollary we deduce:

Corollary 7.1.5. *Let X be a Banach space, let $p \in [1, 2]$ and $q \in [2, \infty]$, let $\mathbf{r} = (r_1, \dots, r_N) \in [1, \infty)^N$ and write*

$$L^{\mathbf{r}}(\mathbf{S}; X) := L^{r_1}(S_1(L^{r_2}(S_2, \dots, L^{r_N}(S_N; X) \dots))).$$

(1) *If X has type p , then $L^{\mathbf{r}}(\mathbf{S}; X)$ has type $p \wedge r := p \wedge r_1 \wedge \dots \wedge r_N$, with*

$$\tau_{p \wedge r, L^{\mathbf{r}}(\mathbf{S}; X); s} \leq \tau_{p, X; s}, \quad s \in [r_1 \vee \dots \vee r_N, \infty).$$

(2) *If X has cotype q , then $L^{\mathbf{r}}(\mathbf{S}; X)$ has cotype $q \vee r := q \vee r_1 \vee \dots \vee r_N$, with*

$$c_{q \vee r, L^{\mathbf{r}}(\mathbf{S}; X); t} \leq c_{q, X; t}, \quad t \in [1, r_1 \wedge \dots \wedge r_N].$$

The point is that the type and cotype estimates only depend on the upper and lower bounds for the sequence $(r_n)_{n=1}^N$, not on the number of elements of this sequence. This phenomenon already appeared in Theorem 4.3.17, where we verified it by a more *ad hoc* argument.

Corollary 7.1.6. *Let $r \in [1, \infty)$, and (S, \mathcal{A}, μ) be a measure space such that $L^r(S)$ is infinite-dimensional. Then*

$$\tau_{p, L^r(S); r} = \begin{cases} 1, & p \leq r \wedge 2, \\ \infty, & p > r \wedge 2; \end{cases}$$

$$c_{q, L^r(S); r} = \begin{cases} \infty, & q < r \vee 2, \\ 1, & q \geq r \vee 2. \end{cases}$$

Proof. The cases with ‘constant 1’ are immediate from Proposition 7.1.4, even without the infinite-dimensionality assumption.

For the cases with ‘constant ∞ ’ (i.e., the failure of the corresponding property), we detail the case of type, that of cotype being similar. Thus, we show that if $\dim L^r(S) = \infty$, then $L^r(S)$ fails type $p > \min\{r, 2\}$. For this we may assume that $1 \leq r < p \leq 2$, the remaining case being immediate from the fact that no Banach space has type greater than 2.

For each $N \geq 1$, the measure space S contains disjoint measurable sets S_1, \dots, S_N of positive and finite measure. Indeed, otherwise S consists of finitely many atoms and possibly a purely infinite part, contradicting the assumption that $L^p(S)$ be infinite-dimensional.

Fix $N \geq 1$. Choose disjoint sets S_1, \dots, S_N of positive finite measure. With $f_n = \mu(S_n)^{-1/r} \mathbf{1}_{S_n}$ we then have, by Fubini’ theorem and disjoint supports,

$$\begin{aligned} \left\| \sum_{n=1}^N \varepsilon_n f_n \right\|_{L^r(\Omega; L^r(S; X))} &= \left\| \sum_{n=1}^N \varepsilon_n f_n \right\|_{L^r(S; L^r(\Omega; X))} \\ &= \left(\sum_{n=1}^N \|\varepsilon_n f_n\|_{L^r(S; L^r(\Omega; X))}^r \right)^{1/r} \\ &= \left(\sum_{n=1}^N \|\varepsilon_n f_n\|_{L^r(\Omega; L^r(S; X))}^r \right)^{1/r} \\ &= \left(\sum_{n=1}^N 1 \right)^{1/r} = N^{1/r}, \end{aligned}$$

whereas

$$\left(\sum_{n=1}^N \|f_n\|_{L^r(S)}^p \right)^{1/p} = \left(\sum_{n=1}^N 1 \right)^{1/p} = N^{1/p}.$$

Letting $N \rightarrow \infty$ we see that $L^r(S)$ cannot have type p . □

The finite-dimensional spaces ℓ_N^1 and ℓ_N^∞ play an important role in the theory of type and cotype, and their type and cotype constants are given in the following proposition.

Proposition 7.1.7. *For $p \in [1, 2]$ and $q \in [2, \infty]$, we have*

$$\tau_{p, \ell_N^1} = N^{1/p'}, \quad c_{q, \ell_N^1} \leq \kappa_{2,1}, \quad c_{q, \ell_N^\infty} = N^{1/q}, \quad (7.2)$$

and

$$\frac{1}{2}([\log_3 N] + 1)^{1/p'} \leq \tau_{p, \ell_N^\infty} \leq (2e \log N)^{1/p'} \vee 2^{1/p'}. \quad (7.3)$$

Proof of (7.2). Let us begin by noting the obvious identities $\tau_{p, \ell_N^p} = 1$ and $c_{q, \ell_N^q} = 1$.

Concerning τ_{p, ℓ_N^1} , we use $\|x\|_{\ell_N^p} \leq \|x\|_{\ell_N^1} \leq N^{1/p'} \|x\|_{\ell_N^p}$ and $\tau_{p, \ell_N^p} = 1$ to obtain

$$\begin{aligned} \left\| \sum_{k=1}^K \varepsilon_k x_k \right\|_{L^p(\Omega; \ell_N^1)} &\leq N^{1/p'} \left\| \sum_{k=1}^K \varepsilon_k x_k \right\|_{L^p(\Omega; \ell_N^p)} \\ &\leq N^{1/p'} \tau_{p, \ell_N^p} \left(\sum_{k=1}^K \|x_k\|_{\ell_N^p}^p \right)^{1/p} \leq N^{1/p'} \left(\sum_{k=1}^K \|x_k\|_{\ell_N^1}^p \right)^{1/p}. \end{aligned}$$

In the converse direction, we choose $x_k = e_k$, the unit vectors, to see that

$$N = \left\| \sum_{n=1}^N \varepsilon_n e_n \right\|_{L^p(\Omega; \ell_N^1)} \leq \tau_{p, \ell_N^1} \left(\sum_{n=1}^N \|e_n\|_{\ell_N^1}^p \right)^{1/p} = \tau_{p, \ell_N^1} N^{1/p}.$$

The case of c_{q, ℓ_N^∞} is similar: We use $\|x\|_{\ell_N^\infty} \leq \|x\|_{\ell_N^q} \leq N^{1/q} \|x\|_{\ell_N^\infty}$ and $c_{q, \ell_N^q} = 1$ to get

$$\begin{aligned} \left(\sum_{k=1}^K \|x_k\|_{\ell_N^\infty}^q \right)^{1/q} &\leq \left(\sum_{k=1}^K \|x_k\|_{\ell_N^q}^q \right)^{1/q} \\ &\leq c_{q, \ell_N^q} \left\| \sum_{k=1}^K \varepsilon_k x_k \right\|_{L^q(\Omega; \ell_N^q)} \leq N^{1/q} \left\| \sum_{k=1}^K \varepsilon_k x_k \right\|_{L^q(\Omega; \ell_N^\infty)}. \end{aligned}$$

Conversely, with $x_k = e_k$, we have

$$N^{1/q} = \left(\sum_{n=1}^N \|e_n\|_{\ell_N^\infty}^q \right)^{1/q} \leq c_{q, \ell_N^\infty} \left\| \sum_{n=1}^N \varepsilon_n e_n \right\|_{L^q(\Omega; \ell_N^\infty)} = c_{q, \ell_N^\infty}.$$

The estimate $c_{q, \ell_N^1} \leq c_{2, \ell_N^1} \leq \kappa_{2,1}$ is a special case of the similar bound for general $L^1(S)$ -spaces (see Corollary 7.1.5) and the Kahane–Khintchine inequality. \square

In order to estimate τ_{p,ℓ_N^∞} from below, we will make use of the bound already proved for τ_{p,ℓ_N^1} , via the following notion, whose deeper connections with type and cotype will be explored later in this chapter:

Definition 7.1.8 (Isomorphic copy of Y in X). *Let X and Y be Banach spaces and let $\lambda \geq 1$ be a constant. We say that X contains a λ -isomorphic copy of Y , and write $Y \subseteq_\lambda X$, if there exist $T \in \mathcal{L}(Y, X)$ and constants $\lambda_1, \lambda_2 > 0$ such that $\lambda_1 \lambda_2 \leq \lambda$ and*

$$\frac{1}{\lambda_1} \|y\| \leq \|Ty\| \leq \lambda_2 \|y\|, \quad y \in Y.$$

We say that X contains an isomorphic copy of Y if X contains a λ -isomorphic copy of Y for some $\lambda \geq 1$.

It is immediate to check that if $Y \subseteq_\lambda X$, then

$$\tau_{p,Y} \leq \lambda \tau_{p,X}, \quad c_{q,Y} \leq \lambda c_{q,X}, \quad (7.4)$$

for all $1 \leq p \leq 2$ and $2 \leq q \leq \infty$. For the present purposes, we will need the following basic example:

Example 7.1.9 (ℓ_N^∞ contains an isomorphic copy of ℓ_n^1). We shall prove that

- (1) for $\mathbb{K} = \mathbb{R}$, ℓ_{2N-1}^∞ contains a 1-isomorphic copy of ℓ_N^1 ;
- (2) for $\mathbb{K} = \mathbb{C}$, ℓ_{JN-1}^∞ contains a $\frac{1}{\cos(\pi/J)}$ -isomorphic copy of ℓ_N^1 for $J \geq 3$.

In particular, $\ell_N^1 \subseteq_2 \ell_{3N-1}^\infty$, and for every $\varepsilon > 0$ there exists $M = M(N, \varepsilon)$ such that $\ell_N^1 \subseteq_{1+\varepsilon} \ell_M^\infty$.

Proof. Consider the index set $\Theta := \{e^{2\pi ik/J} : k = 1, \dots, J\}^{N-1}$ and the operator

$$T : \ell_N^1 \rightarrow \ell^\infty(\Theta) = \ell_{JN-1}^\infty : a = (a_n)_{n=1}^N \mapsto \left(\sum_{n=1}^{N-1} \theta_n a_n + a_N \right)_{\theta \in \Theta},$$

where we take $J = 2$ in the real case and $J \geq 3$ in the complex case.

In the real case, we have $\Theta = \{-1, 1\}^{N-1}$ and with the choice $\theta_n = \operatorname{sgn}(a_n) \operatorname{sgn}(a_N)$ we find that

$$\|Ta\|_{\ell^\infty(\Theta)} = \max_{\theta \in \{-1, 1\}^{N-1}} \left| \sum_{n=1}^{N-1} \theta_n a_n + a_N \right| = \left| \operatorname{sgn}(a_N) \sum_{n=1}^N |a_n| \right| = \|a\|_{\ell^1}.$$

In the complex case, writing $a_n = |a_n|e^{-i\phi_n}$, we choose $\theta_n = e^{i\psi_n}$ such that $|\psi_n - (\phi_n - \phi_N)| \leq \pi/J$ to see that

$$\|Ta\|_{\ell^\infty(\Theta)} \geq \max_{\theta \in \Theta} \Re \left(e^{i\phi_N} \left[\sum_{n=1}^{N-1} \theta_n a_n + a_N \right] \right)$$

$$\begin{aligned}
&\geq \Re\left(\sum_{n=1}^{N-1} |a_n| e^{i(\psi_n - \phi_n + \phi_N)} + |a_N|\right) \\
&= \sum_{n=1}^{N-1} |a_n| \cos(\psi_n - [\phi_n - \phi_N]) + |a_N| \geq \cos(\pi/J) \sum_{n=1}^N |a_n|,
\end{aligned}$$

while clearly $\|Ta\|_{\ell^\infty(\Theta)} \leq \|a\|_{\ell^1}$. \square

We are now ready for:

Proof of (7.3). Concerning τ_{2,ℓ_N^∞} , we use $\|x\|_{\ell_N^\infty} \leq \|x\|_{\ell_N^s} \leq N^{1/s} \|x\|_{\ell_N^\infty}$ and the estimate $\tau_{2,\ell_N^s} \leq \tau_{2,\ell_N^s}^{\mathbb{R}} \leq \kappa_{s,2}^{\mathbb{R}} \leq \sqrt{s-1}$ for $s \in [2, \infty)$ (the first follows from (7.1), the second from Corollary 7.1.6, and the third from Theorem 6.2.4), to obtain

$$\begin{aligned}
\left\| \sum_{k=1}^K \varepsilon_k x_k \right\|_{L^2(\Omega; \ell_N^\infty)} &\leq \left\| \sum_{k=1}^K \varepsilon_k x_k \right\|_{L^2(\Omega; \ell_N^s)} \\
&\leq \tau_{2,\ell_N^s} \left(\sum_{k=1}^K \|x_k\|_{\ell_N^s}^2 \right)^{1/2} \\
&\leq (s-1)^{1/2} N^{1/s} \left(\sum_{k=1}^K \|x_k\|_{\ell_N^\infty}^2 \right)^{1/2}.
\end{aligned}$$

Therefore, $\tau_{2,\ell_N^\infty} \leq (s-1)^{1/2} N^{1/s}$ for $s \in [2, \infty)$. If $N \in \{1, 2\}$, we can take $s = 2$ to find $\tau_{2,\ell_N^\infty} \leq 2^{1/2}$, which implies the upper bound in (7.3) for $p = 2$. If $N \geq 3$, then with $s = 2 \log(N)$ we find

$$\tau_{2,\ell_N^\infty} \leq (2 \log(N) - 1)^{1/2} N^{1/(2 \log(N))} \leq (2 \log(N))^{1/2} e^{1/2},$$

which again implies the upper bound in (7.3) for $p = 2$.

For all $N \geq 1$ we have $\tau_{1,\ell_N^\infty} = 1$. For $p \in (1, 2)$, by interpolation (see Proposition 7.1.3) we obtain

$$\tau_{p,\ell_N^\infty} \leq \tau_{1,\ell_N^\infty}^{1-2/p'} \tau_{2,\ell_N^\infty}^{2/p'} = \tau_{2,\ell_N^\infty}^{2/p'},$$

which, combined with the preceding bound for τ_{2,ℓ_N^∞} , gives the asserted upper bound in (7.3).

The lower bound for τ_{p,ℓ_N^∞} follows from the fact that $\ell_{3^{n-1}}^\infty$ contains a 2-isomorphic copy of ℓ_n^1 , and hence

$$\tau_{p,\ell_N^\infty} \geq \frac{1}{2} \tau_{p,\ell_n^1} = \frac{1}{2} n^{1/p'}$$

for $N \geq 3^{n-1}$. With $n = \lfloor \log_3 N \rfloor + 1$, we have $\tau_{p,\ell_N^\infty} \geq \frac{1}{2} (\lfloor \log_3 N \rfloor + 1)^{1/p'}$. \square

As an immediate consequence of these finite-dimensional bounds of Proposition 7.1.7, we have

Corollary 7.1.10. *The spaces c_0 and ℓ^∞ do not have non-trivial type or finite cotype. The space ℓ^1 has cotype 2, but no non-trivial type.*

Concerning the Schatten class \mathcal{C}^p (see Appendix D for the definition), we have the following result.

Proposition 7.1.11. *For all $p \in (1, \infty)$ the Schatten class \mathcal{C}^p has type $p \wedge 2$ and cotype $p \vee 2$.*

The proposition is also true for $p = 1$, that is to say, \mathcal{C}^1 has cotype 2. This is a deeper result that we shall not prove here.

The result of the proposition is optimal in view of the fact that \mathcal{C}^p contains an isometric copy of ℓ^p . To see this, let $(e_n)_{n \geq 1}$ be the standard unit basis of ℓ^2 . Then, for all scalar sequences $c = (c_n)_{n \geq 1}$,

$$\|c\|_{\ell^p} = \left\| \sum_{n \geq 1} c_n (e_n \otimes e_n) \right\|_{\mathcal{C}^p}.$$

The key to Proposition 7.1.11 is an explicit computation for the case when p is an even integer:

Lemma 7.1.12. $\tau_{2, \mathcal{C}^{2n}} \leq \kappa_{2n, 2}$ for all $n \in \mathbb{Z}_+$.

Proof. We use the results of Appendix D. Iterating the identity for u^*u preceding (D.2) and using Lemma D.1.1, we find that $\|u\|_{\mathcal{C}^{2n}}^{2n} = \text{tr}((u^*u)^n)$. Therefore, if $(\varepsilon_i)_{i \geq 1}$ is a Rademacher sequence,

$$\begin{aligned} \mathbb{E} \left\| \sum_{i=1}^N \varepsilon_i x_i \right\|_{\mathcal{C}^{2n}}^{2n} &= \mathbb{E} \left(\text{tr} \sum_{i_1, j_1, \dots, i_n, j_n \in \{1, \dots, N\}} \bar{\varepsilon}_{i_1} \varepsilon_{j_1} \cdots \bar{\varepsilon}_{i_n} \varepsilon_{j_n} x_{i_1}^* x_{j_1} \cdots x_{i_n}^* x_{j_n} \right) \\ &= \sum_{i_1, j_1, \dots, i_n, j_n \in \{1, \dots, N\}}^* \text{tr}(x_{i_1}^* x_{j_1} \cdots x_{i_n}^* x_{j_n}) \\ &\leq \sum_{i_1, j_1, \dots, i_n, j_n \in \{1, \dots, N\}}^* \|x_{i_1}\|_{\mathcal{C}^{2n}} \cdots \|x_{j_n}\|_{\mathcal{C}^{2n}}, \end{aligned}$$

where $*$ signifies the following restriction in the summation:

- in the real case, each value $k \in \{1, \dots, N\}$ appears an even number of times in the sequence $(i_1, j_1, \dots, i_n, j_n)$;
- in the complex case, each value $k \in \{1, \dots, N\}$ appears an equal number of times in the sequence (i_1, \dots, i_n) and in the sequence (j_1, \dots, j_n) .

Indeed, the second identity follows easily by considering when $\mathbb{E}r^k$ (with a real Rademacher r) or $\mathbb{E}(\varepsilon^k \varepsilon^\ell) = \mathbb{E}(\varepsilon^{\ell-k})$ is zero or one.

Exactly the same computation shows that non-negative numbers a_i satisfy

$$\mathbb{E} \left| \sum_{i=1}^N \varepsilon_i a_i \right|^{2n} = \sum_{i_1, j_1, \dots, i_n, j_n \in \{1, \dots, N\}}^* a_{i_1} a_{j_1} \cdots a_{i_n} a_{j_n}.$$

Using this with $a_i = \|x_i\|_{\mathcal{C}^{2n}}$, we find that

$$\left(\mathbb{E} \left\| \sum_{i=1}^N \varepsilon_i x_i \right\|_{\mathcal{C}^{2n}}^{2n} \right)^{1/2n} \leq \left(\mathbb{E} \left| \sum_{i=1}^N \varepsilon_i \|x_i\|_{\mathcal{C}^{2n}} \right|^{2n} \right)^{1/2n} \leq \kappa_{2n,2} \left(\sum_{i=1}^N \|x_i\|_{\mathcal{C}^{2n}}^2 \right)^{1/2},$$

which is the asserted estimate. □

Proof of Proposition 7.1.11. We first prove the ‘type’ part. The case $p = 2n \in 2\mathbb{Z}_+$ is contained in Lemma 7.1.12. The result for $p \in [2, \infty)$ follows from this by interpolation, using Propositions 7.1.3 and D.3.1. The result for $p \in (1, 2)$ also follows by interpolation again, now using the obvious fact that \mathcal{C}^1 has type 1.

The ‘cotype’ part follows by duality, using Proposition 7.1.13 below and Theorem D.2.6. □

7.1.c Type implies cotype

As it turns out, in many ways non-trivial type is a stronger property than finite cotype. In this subsection we prove two results featuring this phenomenon: if a space X has non-trivial type, then both X and its dual X^* have finite cotype. From Corollary 7.1.10 we already know that neither of these implications is reversible: the space ℓ^1 has cotype 2, yet neither this space itself, nor its predual c_0 and its dual ℓ^∞ have non-trivial type.

We begin with the simple duality result.

Proposition 7.1.13. *If X has type $p \in [1, 2]$, then X^* has cotype $p' \in [2, \infty]$ with $\frac{1}{p} + \frac{1}{p'} = 1$. Moreover, $c_{p', X^*} \leq \tau_{p, X}$.*

Proof. In the proof we take $p \in (1, 2]$; the case $p = 1$ is trivial. Let $x_1^*, \dots, x_N^* \in X^*$ and $\varepsilon > 0$ be given and choose norm one vectors $x_1, \dots, x_N \in X$ such that $\langle x_n, x_n^* \rangle \geq (1 - \varepsilon) \|x_n^*\|$. If $a = (a_1, \dots, a_N)$ is a sequence of scalars we write $\|a\|_p = \left(\sum_{n=1}^N |a_n|^p \right)^{1/p}$. By Hölder’s inequality,

$$\begin{aligned} (1 - \varepsilon) \left(\sum_{n=1}^N \|x_n^*\|^{p'} \right)^{1/p'} &\leq \left(\sum_{n=1}^N \langle x_n, x_n^* \rangle^{p'} \right)^{1/p'} = \sup_{\|a\|_p \leq 1} \left| \sum_{n=1}^N a_n \langle x_n, x_n^* \rangle \right| \\ &= \sup_{\|a\|_p \leq 1} \left| \mathbb{E} \left\langle \sum_{m=1}^N \varepsilon_m a_m x_m, \sum_{n=1}^N \varepsilon_n x_n^* \right\rangle \right| \end{aligned}$$

$$\begin{aligned}
&\leq \sup_{\|a\|_p \leq 1} \left(\mathbb{E} \left\| \sum_{m=1}^N \varepsilon_m a_m x_m \right\|^p \right)^{1/p} \left(\mathbb{E} \left\| \sum_{n=1}^N \varepsilon_n x_n^* \right\|^{p'} \right)^{1/p'} \\
&\leq \tau_{p,X} \sup_{\|a\|_p \leq 1} \left(\sum_{m=1}^N |a_m|^p \|x_m\|^p \right)^{1/p} \left(\mathbb{E} \left\| \sum_{n=1}^N \varepsilon_n x_n^* \right\|^{p'} \right)^{1/p'} \\
&= \tau_{p,X} \left(\mathbb{E} \left\| \sum_{n=1}^N \varepsilon_n x_n^* \right\|^{p'} \right)^{1/p'}.
\end{aligned}$$

Since $\varepsilon > 0$ was arbitrary, this proves the result. \square

The deduction of cotype from type within the same space is deeper:

Theorem 7.1.14 (König–Tzafriri). *If X has type $p \in (1, 2]$, then it has cotype $q = 2 + (L\tau_{p,X})^{p'}$ with constant $c_{q,X} \leq J$, where $(J, L) = (2, 2)$ if $\mathbb{K} = \mathbb{R}$ and $(J, L) = (3, 6)$ if $\mathbb{K} = \mathbb{C}$.*

For a finite sequence $(x_i)_{i=1}^n$ we set

$$\|(x_i)_{i=1}^n\|_{\varepsilon^p(X)} := \left\| \sum_{i=1}^n \varepsilon_i x_i \right\|_{L^p(\Omega; X)}.$$

These norms and associated spaces have been studied in Section 6.3. Here it will be convenient to work with finite sequences and to view the space of finite sequences as a subspace of $\varepsilon^p(X)$ by adding zeros. For later use we record the simple fact, which is proved by writing out the definitions, that if X has type p , then so has $\varepsilon^p(X)$ and $\tau_{\varepsilon^p(X)} = \tau_{p,X}$.

The proof makes use of auxiliary coefficients $\gamma_{p,X}(n)$ defined as the least constants in the estimate

$$\min_{1 \leq k \leq n} \|v_k\|_{\varepsilon^p(X)} \leq \gamma_{p,X}(n) \|[v_k]_{k=1}^n\|_{\varepsilon^p(X)}$$

over all choices of sequences $v_k = (x_i^k)_{i=1}^{I_k} \in \varepsilon^p(X)$ with $I_k \in \mathbb{N}$. Here we use the convention that $[v_k]_{k=1}^n$ is the finite sequence obtained by putting all sequences together in one larger sequence in the following way:

$$[v_k]_{k=1}^n = (x_1^1, \dots, x_{I_1}^1, x_1^2, \dots, x_{I_2}^2, \dots, x_1^n, \dots, x_{I_n}^n).$$

Changing the order of the sequence does not influence the norm in $\varepsilon^p(X)$.

Lemma 7.1.15. *We have $1 = \gamma_{p,X}(1) \geq \gamma_{p,X}(2) \geq \dots$ and*

$$\gamma_{p,X}(mn) \leq \gamma_{p,X}(m)\gamma_{p,X}(n).$$

Proof. Clearly $\min_{1 \leq k \leq n} \|v_k\|$ is decreasing in n , while the contraction principle implies that $\|[v_k]_{k=1}^n\|_{L^p(\Omega; X)}$ is increasing in n ; from this the decreasing

nature of $\gamma_{p,X}(n)$ is evident. For the sub-multiplicativity estimate, let v_{jk} , $1 \leq j \leq m$, $1 \leq k \leq n$, be an array of elements of $\varepsilon^p(X)$. Then

$$\begin{aligned} \min_{\substack{1 \leq j \leq m \\ 1 \leq k \leq n}} \|v_{jk}\|_{\varepsilon^p(X)} &\leq \min_{1 \leq j \leq m} \gamma_{p,X}(n) \|[v_{jk}]_{k=1}^n\|_{\varepsilon^p(X)} \\ &\leq \gamma_{p,X}(m) \gamma_{p,X}(n) \|[v_{jk}]_{j,k=1}^{m,n}\|_{\varepsilon^p(X)}, \end{aligned}$$

where we first applied the definition of $\gamma_{p,X}(n)$ to $[v_{jk}]_{k=1}^n$ for each fixed j , and then the definition of $\gamma_{p,X}(m)$ to the functions $[v_{jk}]_{j,k=1}^{m,n}$ (the order is irrelevant for the norm in $\varepsilon^p(X)$). \square

Proof of Theorem 7.1.14. The plan is to derive a bound on $\gamma_{p,X}(n)$ from the assumption on type, and use this to derive a bound on cotype.

For a given M , the definition of $\gamma_{p,X}(M)$ and normalisation implies that we can find a sequence $v_1, \dots, v_M \in \varepsilon^p(X)$ in such a way that

$$\min_{1 \leq k \leq M} \|v_k\|_{\varepsilon^p(X)} = 1, \quad \|[v_k]_{k=1}^M\|_{\varepsilon^p(X)} \leq \frac{1 + \epsilon}{\gamma_{p,X}(M)}.$$

Suppose that some v_k has norm $\|v_k\|_{\varepsilon^p(X)} > 1$. If we replace this v_k by $v'_k := \|v_k\|_{\varepsilon^p(X)}^{-1} v_k$, the equality above remains valid, and so does the inequality by the contraction principle. Repeating this for all k , we may in fact assume that $\|v_k\|_{\varepsilon^p(X)} \equiv 1$. Another application of the contraction principle then shows, for any sequence of scalars c_1, \dots, c_M , that

$$\max_{1 \leq k \leq M} \|c_k v_k\|_{\varepsilon^p(X)} \leq \|[c_k v_k]_{k=1}^M\|_{\varepsilon^p(X)} \leq \left(\max_{1 \leq k \leq M} |c_k| \right) \frac{1 + \epsilon}{\gamma_{p,X}(M)}.$$

Hence, $e_k \mapsto v_k$ realises a $(1 + \epsilon)/\gamma_{p,X}(M)$ -isomorphic copy of ℓ_M^∞ into $\varepsilon^p(X)$ in the sense of Definition 7.1.8.

In what follows, let $(J, K) := (2, 1)$ if $\mathbb{K} = \mathbb{R}$, and $(J, K) := (3, 2)$ if $\mathbb{K} = \mathbb{C}$. For $M = J^{m-1}$, the space ℓ_m^1 admits a K -isomorphic embedding into ℓ_M^∞ by the result of Example 7.1.9, and hence a $K(1 + \epsilon)/\gamma_{p,X}(M)$ -isomorphic embedding into $\varepsilon^p(X)$. Thus

$$\tau_{p, \ell_m^1} \leq \frac{K(1 + \epsilon)}{\gamma_{p,X}(M)} \tau_{p, \varepsilon^p(X)} = \frac{K(1 + \epsilon)}{\gamma_{p,X}(M)} \tau_{p,X},$$

and being true for every $\epsilon > 0$, this also holds with $\epsilon = 0$. On the other hand, (7.2) states that $\tau_{p, \ell_m^1} = m^{1/p'}$, and thus $\gamma_{p,X}(M) \leq K \tau_{p,X} m^{-1/p'}$.

Let us consider the smallest m such that $K \tau_{p,X} m^{-1/p'} \leq J^{-1}$. Thus $\gamma_{p,X}(M^k) \leq \gamma_{p,X}(M)^k \leq K \tau_{p,X} m^{-1/p'} \leq J^{-k}$ and $K \tau_{p,X} (m-1)^{-1/p'} > J^{-1}$, so that $m-1 < (JK \tau_{p,X})^{p'}$.

We then turn to the estimation of the cotype constant. Consider a sequence of vectors x_1, x_2, \dots, x_N enumerated in the decreasing order of the norm $\|x_1\| \geq \|x_2\| \geq \dots$. Thus applying the definition of $\gamma_{p,X}(n)$ with singleton sequences $v_j = (x_j)$ gives

$$\begin{aligned} \|x_n\| &= \min_{1 \leq j \leq n} \|x_j\| \leq \gamma_{p,X}(n) \left\| (x_j)_{j=1}^n \right\|_{\varepsilon^p(X)} \\ &\leq \gamma_{p,X}(n) \left\| \sum_{j=1}^n \varepsilon_j x_j \right\|_{L^2(\Omega; X)} =: \gamma_{p,X}(n) E_N. \end{aligned}$$

Then, for any $q > m$,

$$\begin{aligned} \sum_{n=1}^N \|x_n\|^q &\leq \sum_{n=1}^N \gamma_{p,X}(n)^q E_N^q \leq \sum_{k=0}^{\infty} \sum_{n=M^k}^{M^{k+1}-1} \gamma_{p,X}(M^k)^q E_N^q \\ &\leq \sum_{k=0}^{\infty} M^{k+1} J^{-kq} E_N^q = M \sum_{k=0}^{\infty} J^{(m-q)k} E_N^q = \frac{M E_N^q}{1 - J^{m-q}}. \end{aligned}$$

Requiring $q \geq m + 1$, we have $M/(1 - J^{m-q}) \leq J^{m-1}/(1 - J^{-1}) \leq J^m \leq J^q$, and hence

$$\left(\sum_{n=1}^N \|x_n\|^q \right)^{1/q} \leq J E_N = J \left\| \sum_{j=1}^N \varepsilon_j x_j \right\|_{L^2(\Omega; X)} \leq J \left\| \sum_{j=1}^N \varepsilon_j x_j \right\|_{L^q(\Omega; X)}.$$

Recalling that $m - 1 < (JK\tau_{p,X})^{p'}$, the set of admissible $q \geq m + 1$ includes at least all $q \geq 2 + (JK\tau_{p,X})^{p'}$. \square

7.1.d Type and cotype for general random sequences

The notions of type and cotype have been defined in terms of Rademacher variables. However, they immediately extend to more general classes of random variables:

Proposition 7.1.16. *Let X be a Banach space, let $p \in [1, 2]$ and $q \in [2, \infty]$ and let $(\eta_n)_{n=1}^N$ be a sequence of X -valued independent symmetric random variables. Then the following assertions hold:*

(1) *If X has type p and the random variables $(\eta_n)_{n=1}^N$ are in $L^p(\Omega; X)$, then*

$$\left(\mathbb{E} \left\| \sum_{n=1}^N \eta_n \right\|^p \right)^{1/p} \leq \tau_{p,X} \left(\sum_{n=1}^N \mathbb{E} \|\eta_n\|^p \right)^{1/p}.$$

(2) *If X has cotype q and the random variable $(\eta_n)_{n=1}^N$ are in $L^q(\Omega; X)$, then*

$$\left(\sum_{n=1}^N \mathbb{E} \|\eta_n\|^q \right)^{1/q} \leq c_{q,X} \left(\mathbb{E} \left\| \sum_{n=1}^N \eta_n \right\|^q \right)^{1/q}.$$

The reader is reminded that the definition of symmetry takes the scalar field \mathbb{K} into account: by Definition 6.1.4, a random variable η is symmetric if η and $\varepsilon\eta$ are identically distributed for all $\varepsilon \in \mathbb{K}$ with $|\varepsilon| = 1$.

Proof. (1): Let $(\varepsilon_n)_{n \geq 1}$ be a Rademacher sequence on a probability space $(\Omega_\varepsilon, \mathbb{P}_\varepsilon)$. It follows from Proposition 6.1.11 that $(\eta_n)_{n=1}^N$ and $(\varepsilon_n \eta_n)_{n=1}^N$ are identically distributed. Therefore, by Fubini's theorem,

$$\begin{aligned} \mathbb{E} \left\| \sum_{n=1}^N \eta_n \right\|^p &= \mathbb{E}_\varepsilon \mathbb{E} \left\| \sum_{n=1}^N \varepsilon_n \eta_n \right\|^p = \mathbb{E} \mathbb{E}_\varepsilon \left\| \sum_{n=1}^N \varepsilon_n \eta_n \right\|^p \\ &\leq \tau_{p,X}^p \mathbb{E} \sum_{n=1}^N \|\eta_n\|^p = \tau_{p,X}^p \sum_{n=1}^N \mathbb{E} \|\eta_n\|^p. \end{aligned}$$

The proof of (2) is similar and is left to the reader. □

Taking $\eta_n = \xi_n x_n$, with $x_n \in X$ and scalar-valued random variables ξ_n , this suggests the following generalisation of the notions of type and cotype. Let ξ be a symmetric random variable with finite moments of all orders, i.e. $\mathbb{E}|\xi|^p < \infty$ for all $1 \leq p < \infty$. Let $(\xi_n)_{n \geq 1}$ be a sequence of independent random variables, each distributed like ξ .

Definition 7.1.17. *Let X be a Banach space, let $p \in [1, 2]$ and $q \in [2, \infty]$.*

(1) *The space X is said to have ξ -type p if there exists a constant $\tau \geq 0$ such that for all finite sequences $x_1, \dots, x_N \in X$ we have*

$$\left(\mathbb{E} \left\| \sum_{n=1}^N \xi_n x_n \right\|^p \right)^{1/p} \leq \tau \left(\sum_{n=1}^N \|x_n\|^p \right)^{1/p}.$$

(2) *The space X is said to have ξ -cotype q if there exists a constant $c \geq 0$ such that for all finite sequences $x_1, \dots, x_N \in X$ we have*

$$\left(\sum_{n=1}^N \|x_n\|^q \right)^{1/q} \leq c \left(\mathbb{E} \left\| \sum_{n=1}^N \xi_n x_n \right\|^q \right)^{1/q},$$

with the usual modification for $q = \infty$.

We denote by $\tau_{p,X}^\xi$ and $c_{q,X}^\xi$ the least admissible constants in (1) and (2) and refer to them as the ξ -type p constant and ξ -cotype q constant of X , respectively. A case of prominent interest involves the case of a standard Gaussian random variable γ , in which case we speak of *Gaussian type and cotype* and denote the corresponding constants by $\tau_{p,X}^\gamma$ and $c_{q,X}^\gamma$. The definitions of real and complex standard Gaussian variables are stated in Section E.2.

Proposition 7.1.18. *Let X be a Banach space, $p \in [1, 2]$ and $q \in [2, \infty]$. Let $(\xi_n)_{n \geq 1}$ be a sequence of independent symmetric random variables, each equidistributed with a given non-zero random variable ξ .*

(1) *If $\xi \in L^p(\Omega)$, then X has type p if and only if it has ξ -type p , and*

$$\|\xi\|_1 \tau_{p,X} \leq \tau_{p,X}^\xi \leq \|\xi\|_p \tau_{p,X}.$$

(2) if $\xi \in L^q(\Omega)$ and X has cotype q , then it also has ξ -cotype q , and

$$c_{q,X}^\xi \leq \frac{1}{\|\xi\|_q} c_{q,X}.$$

Proof. The upper bounds for the ξ -(co)type constants by the (co)type constants follow from Proposition 7.1.16, where we take $\eta_n = \xi_n x_n$. The lower bound for $\tau_{p,X}^\xi$ follows from Proposition 6.1.15. \square

The corresponding converse result for cotype q holds as well (see Corollary 7.2.9), but is considerably more difficult to prove. For the moment we content ourselves with the following weaker converse.

Proposition 7.1.19. *If X has ξ -cotype q , then it has cotype r for every $r > q$, and*

$$c_{r,X} \leq 2 \left(\frac{r+q}{r-q} \right)^{1/r} \|\xi\|_{3rq/(r-q)} \cdot c_{q,X}^\xi.$$

Proof. We shall assume that $\varepsilon_1, \dots, \varepsilon_N$ and ξ_1, \dots, ξ_N are defined on probability spaces Ω and Ω' respectively and write \mathbb{E} and \mathbb{E}' for the corresponding expectations. Let $x_1, \dots, x_N \in X$. We first derive a version of the cotype q estimate with auxiliary coefficients $\phi(n) > 0$:

$$\begin{aligned} \sum_{n=1}^N \frac{\|x_n\|^q}{\phi(n)^q} &\leq (c_{q,X}^\xi)^q \mathbb{E}' \left\| \sum_{n=1}^N \xi_n \frac{x_n}{\phi(n)} \right\|^q \\ &= (c_{q,X}^\xi)^q \mathbb{E}' \mathbb{E} \left\| \sum_{n=1}^N \varepsilon_n \frac{\xi_n}{\phi(n)} x_n \right\|^q \\ &\leq (c_{q,X}^\xi)^q \mathbb{E}' \left(\sup_{n \geq 1} \frac{|\xi_n|^q}{\phi(n)^q} \right) \mathbb{E} \left\| \sum_{n=1}^N \varepsilon_n x_n \right\|^q \\ &= (c_{q,X}^\xi)^q \left\| \sup_{n \geq 1} \frac{|\xi_n|}{\phi(n)} \right\|_{L^q(\Omega')}^q \left\| \sum_{n=1}^N \varepsilon_n x_n \right\|_{L^q(\Omega; X)}^q, \end{aligned}$$

where we used randomisation and applied the contraction principle. The term involving ξ_n can be estimated as follows, for any $s \geq q$:

$$\left\| \sup_{n \geq 1} \frac{|\xi_n|}{\phi(n)} \right\|_{L^q(\Omega')} \leq \left\| \left(\sum_{n \geq 1} \frac{|\xi_n|^s}{\phi(n)^s} \right)^{1/s} \right\|_{L^s(\Omega')} = \|\xi\|_{L^s(\Omega')} \left(\sum_{n \geq 1} \phi(n)^{-s} \right)^{1/s}.$$

It follows that

$$\sum_{n=1}^N \frac{\|x_n\|^q}{\phi(n)^q} \leq (c_{q,X}^\xi)^q \|\xi\|_{L^s(\Omega')}^q \left(\sum_{n \geq 1} \phi(n)^{-s} \right)^{q/s} \left\| \sum_{n=1}^N \varepsilon_n x_n \right\|_{L^q(\Omega; X)}^q. \quad (7.5)$$

Let us now turn to the actual proof of the proposition. Suppose that the vectors x_1, \dots, x_N are ordered in such a way that $\|x_1\| \geq \|x_2\| \geq \dots \geq \|x_N\|$. If ϕ is increasing, for $1 \leq m \leq N$ we have

$$\frac{\|x_m\|^q}{\phi(m)^q} = \min_{1 \leq n \leq m} \frac{\|x_n\|^q}{\phi(n)^q} \leq \frac{1}{m} \sum_{n=1}^m \frac{\|x_n\|^q}{\phi(n)^q} \leq \frac{1}{m} \sum_{n=1}^N \frac{\|x_n\|^q}{\phi(n)^q} =: \frac{1}{m} S^q.$$

For $r > q$, choosing $\phi(m) := m^\beta$ with $\beta := \frac{1}{2}(\frac{1}{q} - \frac{1}{r})$, and using that for any $\alpha > 1$ we have

$$\sum_{m \geq 1} m^{-\alpha} = 1 + \sum_{m \geq 2} m^{-\alpha} \leq 1 + \int_1^\infty t^{-\alpha} dt = 1 - \frac{1}{1 - \alpha}, \quad (7.6)$$

we obtain

$$\begin{aligned} \sum_{m=1}^N \|x_m\|^r &\leq \sum_{m=1}^\infty m^{-r/q} \phi(m)^r S^r = \sum_{m=1}^\infty m^{-r/q+r\beta} S^r \\ &\leq \left(1 - \frac{1}{1 - r/q + r\beta}\right) S^r = \frac{r+q}{r-q} S^r. \end{aligned} \quad (7.7)$$

Choosing $s := \frac{3}{2}\beta^{-1}$ and using (7.6) again,

$$\left(\sum_{n \geq 1} \phi(n)^{-s}\right)^{1/s} = \left(\sum_{n \geq 1} n^{-s\epsilon}\right)^{1/s} \leq \left(\frac{s\epsilon}{s\epsilon - 1}\right)^{1/s} = 3^{2\epsilon/3} \leq 2, \quad (7.8)$$

since $\epsilon \leq \frac{1}{2q} \leq \frac{1}{4}$. Combination of (7.7) with the estimate for S^q of (7.5) and substituting the estimate of (7.8), we obtain

$$\left(\sum_{m=1}^N \|x_m\|^r\right)^{1/r} \leq \left(\frac{r+q}{r-q}\right)^{1/r} \cdot c_{q,X}^\xi \cdot \|\xi\|_{L^s(\Omega')} \cdot 2 \cdot \left\| \sum_{n=1}^N \varepsilon_n x_n \right\|_{L^q(\Omega; X)}$$

where $s = 3/(2\epsilon) = 3rq/(r - q)$. This completes the proof. □

7.1.e Extremality of Gaussians in (co)type 2 spaces

Spaces with type 2 or cotype 2 enjoy some special properties that do not have a full counterpart in spaces with type $p < 2$ or cotype $q > 2$. An example is the following comparison principle, which can be viewed as an extremal property of the Gaussian random variables.

We fix a measure space (S, \mathcal{A}, μ) . As always, $(\gamma_n)_{n \geq 1}$ denotes a Gaussian sequence on a probability space (Ω, \mathbb{P}) .

Theorem 7.1.20. *Let X be a Banach space and $(f_n)_{n=1}^N$ be an orthogonal system in $L^2(S)$.*

(1) *If X has Gaussian cotype 2, then for all $x_1, \dots, x_N \in X$,*

$$\left\| \sum_{n=1}^N f_n x_n \right\|_{L^2(S; X)} \leq c_{2,X}^\gamma \sup_{1 \leq n \leq N} \|f_n\|_{L^2(S)} \left\| \sum_{n=1}^N \gamma_n x_n \right\|_{L^2(\Omega; X)}.$$

(2) If X has Gaussian type 2, then for all $x_1, \dots, x_N \in X$,

$$\inf_{1 \leq n \leq N} \|f_n\|_{L^2(S)} \left\| \sum_{n=1}^N \gamma_n x_n \right\|_{L^2(\Omega; X)} \leq \tau_{2, X}^\gamma \left\| \sum_{n=1}^N f_n x_n \right\|_{L^2(S; X)}.$$

This result can be derived from Theorems 9.2.10 and 9.2.11. To keep the presentation self-contained we present a more direct argument using the following approximation result:

Lemma 7.1.21. *Let $(f_n)_{n=1}^N$ be an orthonormal system in $L^2(S)$. Given any $\epsilon > 0$, there exists another orthonormal system $(s_n)_{n=1}^N$ consisting of simple functions with $\|s_n - f_n\|_2 \leq \epsilon$ for all $n = 1, \dots, N$.*

Proof. Assume for induction that we have already found simple functions s_1, \dots, s_{k-1} such that $\|s_j - f_j\|_2 \leq \epsilon_j$ for some small numbers $\epsilon_j > 0$, and these s_j are orthonormal. (The assumption is vacuous for $k = 1$.) We construct s_k as follows. Let first s'_k be any simple function such that $\|s'_k - f_k\|_2 \leq \epsilon'_k$. Let

$$s''_k := s'_k - \sum_{j=1}^{k-1} (s_j | s'_k) s_j$$

be its projection orthogonal to the s_j 's. Then, using $(f_j | f_k) = 0$, we have

$$s''_k - f_k = s'_k - f_k - \sum_{j=1}^{k-1} (s_j | s'_k - f_k) s_j - \sum_{j=1}^{k-1} (s_j - f_j | f_k) s_j,$$

and hence (noting that the first and second term together are of the form $(I - P)(s'_k - f_k)$ with P an orthogonal projection)

$$\|s''_k - f_k\|_2 \leq \|s'_k - f_k\|_2 + \sum_{j=1}^{k-1} \|s_j - f_j\|_2 \leq \epsilon'_k + \sum_{j=1}^{k-1} \epsilon_j =: \epsilon''_k.$$

Finally, we set $s_k := \|s''_k\|_2^{-1} s''_k$ so that

$$s_k - f_k = \frac{s''_k - f_k}{\|s''_k\|_2} + \frac{1 - \|s''_k\|_2}{\|s''_k\|_2} f_k.$$

From $\|f_k\|_2 = 1$ we have $|1 - \|s''_k\|_2| \|f_k\|_2 = |1 - \|s''_k\|_2| = \|\|f_k\|_2 - \|s''_k\|_2\|$ and $\|s''_k\|_2 \geq \|f_k\|_2 - \|s''_k - f_k\|_2 = 1 - \|s''_k - f_k\|_2$, and therefore

$$\|s_k - f_k\|_2 \leq \frac{\|s''_k - f_k\|_2}{\|s''_k\|_2} + \frac{\|\|f_k\|_2 - \|s''_k\|_2\|}{\|s''_k\|_2} \leq \frac{2\|s''_k - f_k\|_2}{1 - \|s''_k - f_k\|_2} \leq \frac{2\epsilon''_k}{1 - \epsilon''_k} =: \epsilon_k.$$

Thus we have increased the length of the simple orthonormal sequence with a new function s_k that is within ϵ_k of the original f_k . It is clear from above that if the previous number $\epsilon_1, \dots, \epsilon_{k-1}, \epsilon'_k$ are small, then ϵ_k will be small as well. So if we pick a small enough ϵ_1 and $\epsilon'_1, \dots, \epsilon'_N$, relative to the given ϵ , then all $\epsilon_1, \dots, \epsilon_N$ will remain smaller than this ϵ . \square

Proof of Theorem 7.1.20. We may assume that $a_n := \|f_n\|_{L^2(S)} \neq 0$ for all n . Writing $f_n = a_n \phi_n$, the functions ϕ_n are orthonormal, and the asserted bounds for f_n will follow from the analogous bounds for ϕ_n by the contraction principle. So we may assume without loss of generality that the functions f_n are orthonormal to begin with. By the continuous dependence on $f_n \in L^2(S)$ of the terms occurring in (1) and (2), invoking the approximation result of Lemma 7.1.21 we may further assume that each f_n is a simple function, say $f_n = \sum_{m=1}^M a_{nm} \mathbf{1}_{A_m}$, where we may clearly choose representations with the same disjoint sets A_m for each n .

Then

$$\begin{aligned} \left\| \sum_{n=1}^N f_n x_n \right\|_{L^2(S;X)} &= \left(\sum_{m=1}^M \mu(A_m) \left\| \sum_{n=1}^N a_{nm} x_n \right\|^2 \right)^{1/2} \\ &\begin{cases} \leq c_{2,X}^\gamma \\ \geq (\tau_{2,X}^\gamma)^{-1} \end{cases} \times \left\| \sum_{m=1}^M \gamma_m \mu(A_m)^{1/2} \sum_{n=1}^N a_{nm} x_n \right\|_{L^2(\Omega;X)}, \end{aligned}$$

where the norm on the right can be rearranged into

$$\left\| \sum_{n=1}^N \left(\sum_{m=1}^M \mu(A_m)^{1/2} a_{nm} \gamma_m \right) x_n \right\|_{L^2(\Omega;X)} =: \left\| \sum_{n=1}^N \tilde{\gamma}_n x_n \right\|_{L^2(\Omega;X)}.$$

Since $q_{nm} := \mu(A_m)^{1/2} a_{nm}$ satisfies

$$\sum_{m=1}^M q_{nm} q_{km} = \sum_{m=1}^M \mu(A_m) a_{nm} a_{km} = \int_S f_n f_k d\mu = \delta_{nk},$$

the transformed sequence $\tilde{\gamma}_n := \sum_{m=1}^M q_{nm} \gamma_m$ is another independent standard Gaussian sequence. This completes the proof. \square

If $(f_n)_{n=1}^N$ is any sequence of functions in $L^2(S)$ and $(\varepsilon_n)_{n=1}^N$ is a Rademacher sequence, then $(\varepsilon_n f_n)_{n=1}^N$ is orthogonal in $L^2(S \times \Omega)$. Hence Theorem 7.1.20 implies:

Corollary 7.1.22. *Let X be a Banach space and $(f_n)_{n=1}^N$ be an arbitrary sequence in $L^2(S)$.*

(1) *If X has cotype 2, then for all $x_1, \dots, x_N \in X$,*

$$\left\| \sum_{n=1}^N \varepsilon_n f_n x_n \right\|_{L^2(\Omega;L^2(S;X))} \leq c_{2,X}^\gamma \sup_{1 \leq n \leq N} \|f_n\|_{L^2(S)} \left\| \sum_{n=1}^N \gamma_n x_n \right\|_{L^2(\Omega;X)}.$$

(2) *If X has type 2, then for all $x_1, \dots, x_N \in X$,*

$$\inf_{1 \leq n \leq N} \|f_n\|_{L^2(S)} \left\| \sum_{n=1}^N \gamma_n x_n \right\|_{L^2(\Omega;X)} \leq \tau_{2,X}^\gamma \left\| \sum_{n=1}^N \varepsilon_n f_n x_n \right\|_{L^2(\Omega;L^2(S;X))}.$$

As a corollary we obtain the following comparison result for Gaussian and Rademacher sums in spaces with Gaussian cotype 2.

Corollary 7.1.23. *Let X be a Banach space with Gaussian cotype 2. Then the L^2 -norms of Gaussian and Rademacher sums are comparable, and*

$$\begin{aligned} \frac{1}{\|\gamma\|_1} \left\| \sum_{n=1}^N \varepsilon_n x_n \right\|_{L^2(\Omega; X)} &\leq \left\| \sum_{n=1}^N \gamma_n x_n \right\|_{L^2(\Omega; X)} \\ &\leq 4 \sqrt{\log(2c_{2,X}^\gamma)} \left\| \sum_{n=1}^N \varepsilon_n x_n \right\|_{L^2(\Omega; X)}. \end{aligned}$$

Proof. The first estimate has already been proved in Proposition 6.1.15 and doesn't require the cotype 2 assumption. For the second one, we use randomisation (see Proposition 6.1.11) with a Rademacher sequence $(\varepsilon'_n)_{n \geq 1}$ on a distinct probability space (Ω', \mathbb{P}') to obtain

$$\begin{aligned} \left\| \sum_{n=1}^N \gamma_n x_n \right\|_{L^2(\Omega; X)} &= \left\| \sum_{n=1}^N \varepsilon'_n |\gamma_n| x_n \right\|_{L^2(\Omega \times \Omega'; X)} \\ &= \left\| \sum_{n=1}^N \varepsilon'_n \left(|\gamma_n| \wedge t + (|\gamma_n| - t)_+ \right) x_n \right\|_{L^2(\Omega \times \Omega'; X)} \\ &\leq t \left\| \sum_{n=1}^N \varepsilon'_n x_n \right\|_{L^2(\Omega'; X)} + c_{2,X}^\gamma \|(|\gamma| - t)_+\|_2 \left\| \sum_{n=1}^N \gamma_n x_n \right\|_{L^2(\Omega; X)}, \end{aligned}$$

where the first term was estimated by the contraction principle, and the second one by Corollary 7.1.22 with $f_n = (|\gamma_n| - t)_+$. Next, we observe that

$$\begin{aligned} \|(|\gamma| - t)_+\|_2^2 &= \int_0^\infty 2\lambda \mathbb{P}((|\gamma| - t)_+ > \lambda) \, d\lambda = \int_0^\infty 2\lambda \mathbb{P}(|\gamma| > t + \lambda) \, d\lambda \\ &\leq \int_0^\infty 2\lambda e^{-t^2/2} \mathbb{P}(|\gamma| > \lambda) \, d\lambda = e^{-t^2/2} \|\gamma\|_2^2 = e^{-t^2/2}, \end{aligned}$$

where we used the estimate $\mathbb{P}(|\gamma| > t + \lambda) \leq e^{-t^2/2} \mathbb{P}(|\gamma| > \lambda)$ (see Lemma E.2.18 (1) in the real case and (E.8) in the complex case). Now, let us choose $t := 2\sqrt{\log(2c_{2,X}^\gamma)}$, so that $c_{q,X}^\gamma e^{-t^2/4} = \frac{1}{2}$. We then have

$$\begin{aligned} \left\| \sum_{n=1}^N \gamma_n x_n \right\|_{L^2(\Omega; X)} \\ \leq 2\sqrt{\log(2c_{2,X}^\gamma)} \left\| \sum_{n=1}^N \varepsilon'_n x_n \right\|_{L^2(\Omega'; X)} + \frac{1}{2} \left\| \sum_{n=1}^N \gamma_n x_n \right\|_{L^2(\Omega; X)}. \end{aligned}$$

Absorbing the (obviously finite) last term in the left-hand side, we obtain the assertion. \square

We will use this to prove that Gaussian cotype 2 is equivalent to cotype 2 (so that in the preceding corollary the Gaussian cotype 2 assumption can be replaced by cotype 2).

Corollary 7.1.24. *A Banach space X has cotype 2 if and only if it has Gaussian cotype 2, and in this case*

$$c_{2,X}^\gamma \leq c_{2,X} \leq 4c_{2,X}^\gamma \sqrt{\log(2c_{2,X}^\gamma)}.$$

Proof. The first estimate is contained in Proposition 7.1.18, observing that $\|\gamma\|_2 = 1$. For the second estimate, we have

$$\begin{aligned} \left(\sum_{n=1}^N \|x_n\|^2\right)^{1/2} &\leq c_{2,X}^\gamma \left\| \sum_{n=1}^N \gamma_n x_n \right\|_{L^2(\Omega; X)} \\ &\leq c_{2,X}^\gamma \cdot 4\sqrt{\log(2c_{2,X}^\gamma)} \left\| \sum_{n=1}^N \varepsilon_n x_n \right\|_{L^2(\Omega; X)}, \end{aligned}$$

using Corollary 7.1.23 in the second step. □

As we shall see in the next section, the last two corollaries have analogues for the general cotype q case; however, the proofs are complicated by the fact that a reasonable cotype $q > 2$ analogue of Theorem 7.1.20 does not exist, and the cotype $q > 2$ version of Corollary 7.1.22 is somewhat weaker.

7.2 Comparison theorems under finite cotype

In this section we present several comparison results for random sums in spaces with finite (Gaussian) cotype q . Among other things, in Section 7.2.d we will show that Gaussian cotype q is equivalent to cotype q , and that Gaussian and Rademacher sums are comparable under finite cotype q . Furthermore, in Section 7.2.e we derive an extension of Khintchine’s inequality for Banach lattices. This will be used in Theorem 7.5.20 to prove that Banach lattices with finite cotype have Pisier’s contraction property.

The comparison results of this section will also play an important role in Section 8.5.c, where they are used to find sufficient conditions for R -boundedness for integral operators.

The main tool for the proof of the comparison results is a factorisation theorem of Pisier for so-called $(q, 1)$ -summing operators. We do not aim at presenting a systematic account of the theory of summing operators and limit ourselves strictly to those results that will be needed later on.

7.2.a Summing operators

Let X and Y be Banach spaces and let $p, q \in [1, \infty)$.

Definition 7.2.1. An operator $T \in \mathcal{L}(X, Y)$ is called (q, p) -summing if there exists a constant $C \geq 0$ such that for all finite sequences $(x_n)_{n=1}^N$ in X ,

$$\left(\sum_{n=1}^N \|Tx_n\|^q \right)^{1/q} \leq C \sup_{\|x^*\| \leq 1} \left(\sum_{n=1}^N |\langle x_n, x^* \rangle|^p \right)^{1/p}.$$

The least admissible constant C is called the (q, p) -summing norm of T and is denoted by $\pi_{q,p}(T)$, or just $\pi_p(T)$ if $q = p$.

By taking $x_n = \lambda_n x$ for some fixed vector $x \in X$, one easily checks that the only operator which is (q, p) -summing for some $q < p$, is the zero operator. Therefore, we will only consider indices $p \leq q$ in what follows.

Remark 7.2.2. In the important special case when X is a closed subspace of $C(K)$, with K a compact Hausdorff space, the right-hand side in the inequality of Definition 7.2.1 can be expressed as follows, where $\frac{1}{p} + \frac{1}{p'} = 1$:

$$\begin{aligned} \sup_{\|x^*\| \leq 1} \left(\sum_{n=1}^N |\langle x_n, x^* \rangle|^p \right)^{1/p} &= \sup_{\|x^*\| \leq 1} \sup_{\|a\|_{\ell_N^{p'}} \leq 1} \left| \left\langle \sum_{n=1}^N a_n x_n, x^* \right\rangle \right| \\ &= \sup_{\|a\|_{\ell_N^{p'}} \leq 1} \left\| \sum_{n=1}^N a_n x_n \right\| \\ &= \sup_{k \in K} \sup_{\|a\|_{\ell_N^{p'}} \leq 1} \left| \sum_{n=1}^N a_n x_n(k) \right| \\ &= \max_{k \in K} \left(\sum_{n=1}^N |x_n(k)|^p \right)^{1/p}. \end{aligned} \tag{7.9}$$

Our principal interest to the theory of summing operators stems from their connection to cotype, as shown by the following result:

Proposition 7.2.3. Let X and Y be a Banach spaces, and let Y have finite cotype q . Then every bounded linear operator $T \in \mathcal{L}(X, Y)$ is $(q, 1)$ -summing, with $\pi_{q,1}(T) \leq c_{q,Y} \|T\|$.

Proof. Let $x_1, \dots, x_N \in X$. Then

$$\left(\sum_{n=1}^N \|Tx_n\|_Y^q \right)^{1/q} \leq c_{q,Y} \left\| \sum_{n=1}^N \varepsilon_n Tx_n \right\|_{L^q(\Omega; Y)} \leq c_{q,Y} \|T\| \left\| \sum_{n=1}^N \varepsilon_n x_n \right\|_{L^q(\Omega; X)},$$

where

$$\begin{aligned} \left\| \sum_{n=1}^N \varepsilon_n x_n \right\|_{L^q(\Omega; X)} &\leq \left\| \sum_{n=1}^N \varepsilon_n x_n \right\|_{L^\infty(\Omega; X)} \leq \sup_{\|a\|_{\ell_N^\infty} \leq 1} \left\| \sum_{n=1}^N a_n x_n \right\|_X \\ &= \sup_{\|a\|_{\ell_N^\infty} \leq 1} \sup_{\|x^*\| \leq 1} \left| \sum_{n=1}^N a_n \langle x_n, x^* \rangle \right| = \sup_{\|x^*\| \leq 1} \sum_{n=1}^N |\langle x_n, x^* \rangle| \end{aligned}$$

by interchanging the suprema. □

7.2.b Pisier’s factorisation theorem

The $(q, 1)$ -summing property of operators into a cotype q space, as shown in Proposition 7.2.3, is most efficiently exploited in the case when the domain of the operator is a $C(K)$ -space, via a powerful factorisation theorem due to Pisier that is available in this situation. As a matter of fact, our principal applications of this theorem will only deal with the case when $K = \{1, \dots, N\}$ so that $C(K) = \ell_N^\infty$; we will indicate a couple of places in the proof where the use of some standard but heavy theorems of functional analysis can be avoided in this important special case.

Pisier’s factorisation theorem features the *Lorentz space* $L^{q,1}(\mu)$, consisting of all measurable functions for which the following norm is finite:

$$\|f\|_{L^{q,1}(\mu)} := q \int_0^\infty \mu(|f| > t)^{1/q} dt.$$

Some properties of this space are discussed in Appendix F.

Theorem 7.2.4 (Pisier’s factorisation theorem). *Let K be a compact Hausdorff space and let X be a Banach space. Let $q \in [1, \infty)$. For an operator $T \in \mathcal{L}(C(K), X)$ the following assertions are equivalent:*

- (1) T is $(q, 1)$ summing.
- (2) there exists a constant $C \geq 0$ and a regular Borel probability measure μ on K such that for all $x \in C(K)$,

$$\|Tx\| \leq q^{-1} C \|x\|_{L^{q,1}(\mu)}.$$

- (3) there exists a constant $C \geq 0$ and a regular Borel probability measure μ on K such that for all $x \in C(K)$,

$$\|Tx\| \leq C \|x\|_{L^1(\mu)}^{1/q} \|x\|_{C(K)}^{1/q'}.$$

In this situation, the least constants C in (2) and (3) are equal and satisfy

$$\pi_{q,1}(T) \leq C \leq q^{1/q} \pi_{q,1}(T).$$

Before turning to the proof of Theorem 7.2.4 we give an important corollary, through which most of our applications of the theorem take place:

Corollary 7.2.5. *Let K be a compact Hausdorff space, let X be a Banach space with cotype $q \in [2, \infty)$, and let $p \in (q, \infty)$. For every $T \in \mathcal{L}(C(K), X)$, there exists a regular Borel probability measure μ on K such that for all $x \in C(K)$,*

$$\|Tx\| \leq q^{1/q-1} c_{q,X} \|T\| \|x\|_{L^{q,1}(\mu)} \leq \frac{q^{1/q} p}{p-q} c_{q,X} \|T\| \|x\|_{L^p(\mu)}.$$

In particular, T extends to a bounded operator from $L^p(K, \mu)$ into X .

Proof. By Theorem 7.2.4 there exists a regular Borel probability measure μ on K such that

$$\|Tx\| \leq q^{1/q-1} \pi_{q,1}(T) \|x\|_{L^{q,1}(\mu)} \leq q^{1/q-1} c_{q,X} \|T\| \|x\|_{L^{q,1}(\mu)},$$

using Proposition 7.2.3 in the second step. Using the fact that μ is a probability measure along with Chebyshev's inequality, we have

$$\begin{aligned} q^{-1} \|x\|_{L^{q,1}(\mu)} &= \int_0^\infty \mu(|x| > t)^{1/q} dt \leq \int_0^\infty \left(1 \wedge \frac{\|x\|_p^p}{t^p}\right)^{1/q} dt \\ &= \int_0^{\|x\|_p} dt + \int_{\|x\|_p}^\infty \|x\|_p^{p/q} t^{-p/q} dt = \frac{p}{p-q} \|x\|_p. \end{aligned} \quad (7.10)$$

This gives the second claimed estimate. \square

Proof of Theorem 7.2.4. We prove (1) \Rightarrow (3) \Rightarrow (1) and (2) \Rightarrow (3) \Rightarrow (2).

(1) \Rightarrow (3): We may assume that $T \neq 0$. Fix an integer $n \geq 1$. Let C_n denote the smallest constant which satisfies

$$\left(\sum_{k=1}^n \|Tx_k\|^q\right)^{1/q} \leq C_n \left\| \sum_{k=1}^n |x_k| \right\|_{C(K)}$$

for all $x_1, \dots, x_n \in C(K)$. By (7.9), $\lim_{n \rightarrow \infty} C_n = \pi_{q,1}(T)$. Let $\delta_n := 1 - \frac{1}{n}$. Choose a sequence $(x_k^{(n)})_{k=1}^n$ in $C(K)$ such that

$$1 = \left(\sum_{k=1}^n \|Tx_k^{(n)}\|^q\right)^{1/q} \geq \delta_n C_n \left\| \sum_{k=1}^n |x_k^{(n)}| \right\|_{C(K)}.$$

Since $(\ell_n^q(X))^* = \ell_n^{q'}(X^*)$ we can find functionals $\varphi_1^{(n)}, \dots, \varphi_n^{(n)} \in X^*$ such that $\|(\varphi_k^{(n)})_{k=1}^n\|_{\ell_n^{q'}(X^*)} = 1$ and

$$1 = \sum_{k=1}^n \langle Tx_k^{(n)}, \varphi_k^{(n)} \rangle.$$

By the Riesz representation theorem, $(C(K))^*$ coincides with the space of regular Borel measures on K . (When $K = \{1, \dots, N\}$, it suffices to use the

elementary duality $(\ell_N^\infty)^* = \ell_N^1$, where elements of the latter space can be identified with (regular Borel) measures on $\{1, \dots, N\}$.) Define a functional μ_n on $C(K)$ by

$$\langle y, \mu_n \rangle := \sum_{k=1}^n \langle T(yx_k^{(n)}), \varphi_k^{(n)} \rangle.$$

If $\|y\|_{C(K)} \leq 1$, then

$$\begin{aligned} |\langle y, \mu_n \rangle| &\leq \left(\sum_{k=1}^n |T(yx_k^{(n)})|^q \right)^{1/q} \\ &\leq C_n \left\| \sum_{k=1}^n |yx_k^{(n)}| \right\|_{C(K)} \leq C_n \left\| \sum_{k=1}^n |x_k^{(n)}| \right\|_{C(K)} \leq \delta_n^{-1}. \end{aligned}$$

Therefore $\|\mu_n\|_{(C(K))^*} \leq \delta_n^{-1} \leq 2$.

By the Banach–Alaoglu theorem, the sequence $(\mu_n)_{n \geq 1}$ has a weak*-accumulation point μ in $(C(K))^*$. (In the case that $K = \{1, \dots, N\}$ and $(C(K))^* = \ell_N^1$, we can just apply the relative compactness of bounded sets in a finite-dimensional space.) From $\lim_{n \rightarrow \infty} \delta_n = 1$ we infer that $\|\mu\|_{(C(K))^*} \leq 1$. On the other hand, from $\langle \mathbf{1}, \mu_n \rangle = 1$ we see that $\langle \mathbf{1}, \mu \rangle = 1$, and therefore μ is a probability measure.

To show that μ has the desired properties, fix $x \in C(K)$ with $\|x\|_{C(K)} = 1$. Put $y_k := (1 - |x|)x_k^{(n)}$, $k = 1, \dots, n$, and $y_{n+1} := (C_n \delta_n)^{-1}x$. Then,

$$\begin{aligned} (C_n \delta_n)^{-q} \|Tx\|^q &= \|Ty_{n+1}\|^q = \sum_{k=1}^{n+1} \|Ty_k\|^q - \sum_{k=1}^n \|Ty_k\|^q \\ &\leq C_{n+1}^q \left\| \sum_{k=1}^{n+1} |y_k| \right\|^q - \sum_{k=1}^n \|T((1 - |x|)x_k^{(n)})\|^q \\ &= C_{n+1}^q \left\| \sum_{k=1}^{n+1} |y_k| \right\|^q - |\langle (1 - |x|), \mu_n \rangle|^q. \end{aligned}$$

The pointwise inequality $\sum_{k=1}^n |x_k^{(n)}| \leq (C_n \delta_n)^{-1}$ implies

$$\sum_{k=1}^{n+1} |y_k| = \left(\sum_{k=1}^n |y_k| \right) + |y_{n+1}| \leq (C_n \delta_n)^{-1}(1 - |x|) + (C_n \delta_n)^{-1}|x| = (C_n \delta_n)^{-1}$$

and therefore

$$\|Tx\|^q \leq C_{n+1}^q - (C_n \delta_n)^q |\langle (1 - |x|), \mu_n \rangle|^q.$$

Taking limits along a suitable subsequence we find

$$\|Tx\|^q \leq \pi_{q,1}(T)^q (1 - |\langle (1 - |x|), \mu \rangle|^q)$$

$$\begin{aligned}
&= \pi_{q,1}(T)^q (1 - |1 - \langle x, \mu \rangle|^q) \\
&\leq q \pi_{q,1}(T)^q |\langle x, \mu \rangle| = q \pi_{q,1}(T)^q \|x\|_{L^1(\mu)},
\end{aligned}$$

where we used the mean value theorem. Since $\|x\|_{C(K)} = 1$, this proves that (3) holds, with $C \leq q^{1/q} \pi_{q,1}(T)$.

(3) \Rightarrow (1): Fix $x_1, \dots, x_N \in C(K)$ and put $A := \left\| \sum_{n=1}^N |x_n| \right\|_{C(K)}$. Since $\|x_n\|_{C(K)} \leq A$ we have

$$\begin{aligned}
C^{-1} \left(\sum_{n=1}^N \|Tx_n\|^q \right)^{1/q} &\leq \left(\sum_{n=1}^N \|x_n\|_{L^1(\mu)} \|x_n\|_{C(K)}^{q/q'} \right)^{1/q} \\
&\leq A^{1/q'} \left(\left\| \sum_{n=1}^N |x_n| \right\|_{L^1(\mu)} \right)^{1/q} \leq A = \left\| \sum_{n=1}^N |x_n| \right\|_{C(K)}.
\end{aligned}$$

Now 1 follows from (7.9), with $\pi_{q,1}(T) \leq C$.

(2) \Rightarrow (3): This follows from the elementary estimate

$$\begin{aligned}
\|f\|_{L^{1,q}(\mu)} &= q \int_0^\infty \mu(|f| > t)^{1/q} dt = q \int_0^{\|f\|_\infty} \mu(|f| > t)^{1/q} dt \\
&\leq q \|f\|_\infty^{1/q'} \left(\int_0^\infty \mu(|f| > t) dt \right)^{1/q} = q \|f\|_\infty^{1/q'} \|f\|_1^{1/q}.
\end{aligned}$$

(3) \Rightarrow (2): We first show that $T : C(K) \rightarrow X$ has an extension to a bounded linear operator $\hat{T} : L^\infty(\mu) \rightarrow X$ which satisfies

$$\|\hat{T}x\| \leq C \|x\|_{L^1(\mu)}^{1/q} \|x\|_{L^\infty(\mu)}^{1/q'}, \quad x \in L^\infty(\mu). \quad (7.11)$$

(When $K = \{1, \dots, N\}$, this is trivial, since $C(K) = \ell_N^\infty = L^\infty(\mu)$.)

For any $x \in L^\infty(\mu)$, by Lusin's theorem there exists a sequence of functions $(x_n)_{n \geq 1}$ in $C(K)$ such that $\|x_n\| \leq \|x\|_{L^\infty(\mu)}$ and $\lim_{n \rightarrow \infty} x_n = x$ μ -almost everywhere. By the dominated convergence theorem, $\lim_{n \rightarrow \infty} x_n = x$ in $L^1(\mu)$ and for all $m, n \geq 1$,

$$\begin{aligned}
\|Tx_n - Tx_m\| &\leq C \|x_n - x_m\|_{L^1(\mu)}^{1/q} \|x_n - x_m\|_{L^\infty(\mu)}^{1/q'} \\
&\leq C \|x_n - x_m\|_{L^1(\mu)}^{1/q} (2\|x\|_{L^\infty(\mu)})^{1/q'}.
\end{aligned}$$

Therefore, $(Tx_n)_{n \geq 1}$ is a Cauchy sequence in X , and hence convergent to some $y \in X$. One easily checks that the limit y does not depend on the choice of the sequence $(x_n)_{n \geq 1}$. Defining $\hat{T}x := y$, we see that (7.11) holds.

We shall prove (2) for \hat{T} and for all $x \in L^\infty(\mu)$. By density and the continuity of the inclusion $L^\infty(\mu) \hookrightarrow L^{q,1}(\mu)$ it even suffices to consider μ -simple functions. Let $x = \sum_{n=1}^N a_n \mathbf{1}_{A_n}$ with $|a_1| \geq |a_2| \geq \dots \geq |a_N|$ and A_n disjoint and $\mu(A_n) > 0$. Let $y_k := \sum_{n=1}^k \frac{a_n}{|a_n|} \mathbf{1}_{A_n}$, so that $\|y_k\|_\infty = 1$ and $\|y_k\|_1 = \mu(S_k) := \mu(\bigcup_{n=1}^k A_n)$. Denoting $a_{N+1} := 0$, we observe that

$$\mu(|x| > t) = \mu(S_k) \quad \text{if and only if} \quad |a_{k+1}| \leq t < |a_k|. \quad (7.12)$$

Via the representation

$$x = \sum_{n=1}^N |a_n| \frac{a_n}{|a_n|} \mathbf{1}_{A_n} = \sum_{n=1}^N \sum_{k=n}^N (|a_k| - |a_{k+1}|) \frac{a_n}{|a_n|} \mathbf{1}_{A_n} = \sum_{k=1}^N (|a_k| - |a_{k+1}|) y_k$$

it follows from (7.11) that

$$\begin{aligned} \|\widehat{T}x\| &\leq \sum_{k=1}^N (|a_k| - |a_{k+1}|) \|\widehat{T}y_k\| \leq C \sum_{k=1}^N (|a_k| - |a_{k+1}|) \|y_k\|_{L^1(\mu)}^{1/q} \|y_k\|_{L^\infty(\mu)}^{1/q'} \\ &= C \sum_{k=1}^N (|a_k| - |a_{k+1}|) \mu(S_k)^{1/q} = C \sum_{k=1}^N \int_{|a_{k+1}|}^{|a_k|} \mu(S_k)^{1/q} dt \\ &\stackrel{(7.12)}{=} C \sum_{k=1}^N \int_{|a_{k+1}|}^{|a_k|} \mu(|x| > t)^{1/q} dt = q^{-1} C \|x\|_{L^{q,1}(\mu)}. \end{aligned}$$

This completes the proof. \square

7.2.c Contraction principle with function coefficients

Our next aim is to extend the simple estimates for spaces with cotype 2 of the previous section to spaces with arbitrary finite cotype q . We fix a measure space (S, \mathcal{A}, μ) . As always, $(\varepsilon_n)_{n \geq 1}$ will denote a Rademacher sequence on a probability space (Ω, \mathbb{P}) . The following result should be viewed as an extension of the contraction principle for function coefficients.

Theorem 7.2.6. *Let X be a Banach space with finite cotype q .*

(1) *For all sequences $f_1, \dots, f_N \in L^{q,1}(S)$ and $x_1, \dots, x_N \in X$, we have*

$$\begin{aligned} &\left\| \sum_{n=1}^N \varepsilon_n f_n x_n \right\|_{L^q(S \times \Omega; X)} \\ &\leq c_{q,X} q^{1/q} \int_0^\infty \max_{1 \leq n \leq N} \mu(|f_n| > t)^{1/q} dt \cdot \left\| \sum_{n=1}^N \varepsilon_n x_n \right\|_{L^q(\Omega; X)}. \end{aligned} \quad (7.13)$$

(2) *If $r > q$, then for all sequences $f_1, \dots, f_N \in L^r(S)$ and $x_1, \dots, x_N \in X$,*

$$\begin{aligned} &\left\| \sum_{n=1}^N \varepsilon_n f_n x_n \right\|_{L^r(S; L^q(\Omega; X))} \\ &\leq c_{q,X} \frac{q^{1/q} r}{r - q} \max_{1 \leq n \leq N} \|f_n\|_{L^r(S)} \cdot \left\| \sum_{n=1}^N \varepsilon_n x_n \right\|_{L^q(\Omega; X)}. \end{aligned} \quad (7.14)$$

Of course, the mixed norm in (2) can be easily compared with an $L^r(S \times \Omega; X)$ -norm via the Kahane–Khintchine inequality, but we present the form of the estimate that is most natural for the application of the cotype q assumption.

Proof. (1): Define the operator $T : \ell_N^\infty \rightarrow L^q(\Omega; X)$ by $T(a) := \sum_{n=1}^N \varepsilon_n a_n x_n$. By the Kahane contraction principle,

$$\|T\|_{\mathcal{L}(\ell_N^\infty, L^q(\Omega; X))} \leq \left\| \sum_{n=1}^N \varepsilon_n x_n \right\|_{L^q(\Omega; X)}.$$

Since $L^q(\Omega; X)$ has cotype q with constant $c_{q,X}$ it follows from Corollary 7.2.5 of Pisier’s factorisation theorem that there exists a probability measure ν on $\{1, 2, \dots, N\}$ such that

$$\begin{aligned} \left\| \sum_{n=1}^N \varepsilon_n a_n x_n \right\|_{L^q(\Omega; X)} &= \|Ta\|_{L^q(\Omega; X)} \\ &\leq c_{q,X} q^{1/q-1} \|T\| \|a\|_{\ell_N^{q,1}(\nu)} \end{aligned} \quad (7.15)$$

$$\leq c_{q,X} \frac{q^{1/q} r}{r-q} \|T\| \|a\|_{\ell_N^r(\nu)}, \quad (7.16)$$

where $\ell_N^{q,1}(\nu)$ and $\ell_N^r(\nu)$ denote the Lorentz space $L^{q,1}$ and the space L^r defined on $\{1, \dots, N\}$ with measure ν , and the last estimate was the embedding between these spaces established in (7.10). We shall apply both the intermediate inequality (7.15) and the final one (7.16), in both cases with $a_n = f_n(s)$, in order to establish the two forms of the theorem.

Using (7.15) and taking $L^q(\mu)$ -norms, it follows from Minkowski’s inequality that

$$\begin{aligned} &\left\| \sum_{n=1}^N \varepsilon_n f_n x_n \right\|_{L^q(S; L^q(\Omega; X))} \\ &\leq c_{q,X} q^{1/q} \|T\| \left(\int_S \left(\int_0^\infty \left(\sum_{n=1}^N \nu(n) \mathbf{1}_{\{|f_n(s)| > t\}} \right)^{1/q} dt \right)^q d\mu(s) \right)^{1/q} \\ &\leq c_{q,X} q^{1/q} \|T\| \int_0^\infty \left(\int_S \sum_{n=1}^N \nu(n) \mathbf{1}_{\{|f_n(s)| > t\}} d\mu(s) \right)^{1/q} dt \\ &= c_{q,X} q^{1/q} \|T\| \int_0^\infty \left(\sum_{n=1}^N \nu(n) \mu(|f_n| > t) \right)^{1/q} dt \\ &\leq c_{q,X} q^{1/q} \int_0^\infty \left(\max_{1 \leq n \leq N} \mu(|f_n| > t) \right)^{1/q} dt \cdot \left\| \sum_{n=1}^N \varepsilon_n x_n \right\|_{L^q(\Omega; X)}. \end{aligned}$$

This proves the first assertion.

(2): Using (7.16) and taking $L^r(\mu)$ -norms, we have, abbreviating $C_{q,r} := q^{1/q}r/(r-q)$,

$$\begin{aligned} \left\| \sum_{n=1}^N \varepsilon_n f_n x_n \right\|_{L^r(S; L^q(\Omega; X))} &\leq c_{q,X} C_{q,r} \|T\| \left(\int_S \sum_{n=1}^N \nu(n) |f_n(s)|^r d\mu(s) \right)^{1/r} \\ &= c_{q,X} C_{q,r} \|T\| \left(\sum_{n=1}^N \nu(n) \|f_n\|_{L^r(S)}^r \right)^{1/r} \\ &\leq c_{q,X} C_{q,r} \|T\| \max_{1 \leq n \leq N} \|f_n\|_{L^r(S)} \\ &\leq c_{q,X} \frac{q^{1/q}r}{r-q} \max_{1 \leq n \leq N} \|f_n\|_{L^r(S)} \left\| \sum_{n=1}^N \varepsilon_n x_n \right\|_{L^q(\Omega; X)}. \end{aligned}$$

This proves the second assertion. \square

Remark 7.2.7. Suppose, conversely, that S is non-atomic and that there exists a constant $C \geq 0$ such that

$$\begin{aligned} &\left\| \sum_{n=1}^N \varepsilon_n f_n x_n \right\|_{L^q(S \times \Omega; X)} \\ &\leq C \int_0^\infty \max_{1 \leq n \leq N} \mu(|f_n| > t)^{1/q} dt \cdot \left\| \sum_{n=1}^N \varepsilon_n x_n \right\|_{L^q(\Omega; X)} \end{aligned} \quad (7.17)$$

for all finite sequences $(f_n)_{n=1}^N$ in $L^{q,1}(S)$ and $(x_n)_{n=1}^N$ in X . Then X has cotype q with $c_{q,X} \leq C$. Indeed, let $x_1, \dots, x_N \in X$ be arbitrary. Select disjoint measurable sets S_1, \dots, S_N in S with $\mu(S_1) = \dots = \mu(S_N) \in (0, \infty)$. Letting $f_n = \mu(S_1)^{-1/q} \mathbf{1}_{S_n}$ for $n = 1, 2, \dots, N$, we have

$$\mu(|f_n| > t) = \mu(S_1) \cdot \mathbf{1}_{[0, \mu(S_1)^{-1/q}]}(t)$$

for all $n = 1, \dots, N$, so

$$\int_0^\infty \max_{1 \leq n \leq N} \mu(|f_n| > t)^{1/q} dt = \int_0^{\mu(S_1)^{-1/q}} \mu(S_1)^{1/q} dt = 1.$$

Therefore, by the definition of f_n and (7.17),

$$\sum_{n=1}^N \|x_n\|^q = \left\| \sum_{n=1}^N \varepsilon_n f_n x_n \right\|_{L^q(S \times \Omega; X)}^q \leq C^q \left\| \sum_{n=1}^N \varepsilon_n x_n \right\|_{L^q(\Omega; X)}^q.$$

7.2.d Equivalence of cotype and Gaussian cotype

In Proposition 7.1.18 we have seen that type p implies ξ -type p and vice versa, and that cotype q implies ξ -cotype q . In this subsection we will prove that for

cotype the converse assertion also holds, i.e., ξ -cotype q implies cotype q . In particular this improves the preliminary result of Corollary 7.1.24, where it was shown that ξ -cotype q implies cotype r for all $r > q$.

First we establish a general comparison result, which for $q = 2$ and $\xi = \gamma$ is contained in Corollary 7.1.23.

Proposition 7.2.8. *Let X be a Banach space with ξ -cotype q , where ξ is a symmetric random variable with finite moments of all orders. Then we have equivalence of ξ -sums and Rademacher sums,*

$$\|\xi\|_1 \left\| \sum_{n=1}^N \varepsilon_n x_n \right\|_{L^q(\Omega; X)} \leq \left\| \sum_{n=1}^N \xi_n x_n \right\|_{L^q(\Omega; X)} \leq A_{q,X}^\xi \left\| \sum_{n=1}^N \varepsilon_n x_n \right\|_{L^q(\Omega; X)},$$

with constant

$$A_{q,X}^\xi \leq \min \left\{ 24c_{q,X}^\xi \|\xi\|_{6q}^2, 6\|\xi\|_{4q \log(32c_{q,X}^\xi \|\xi\|_{6q})} \right\}.$$

The second bound for $A_{q,X}^\xi$ is interesting when the moments $\|\xi\|_p$, finite for all p by assumption, are sub-exponentially increasing in p , for this will then beat the linear dependence on $c_{q,X}^\xi$ given by the first upper bound. The sub-exponential growth is manifestly the case in the important application to Gaussian random variables, where one has $\|\gamma\|_p \leq \sqrt{p}$.

Proof. We may assume that the sequences $(\varepsilon_n)_{n=1}^N$ and $(\xi_n)_{n=1}^N$ are defined on distinct probability spaces (Ω, \mathbb{P}) and (Ω', \mathbb{P}') .

The first estimate has already been proved in Proposition 6.1.15. From Proposition 7.1.19 we know that X has cotype r , for every $r > q$, with

$$c_{r,X} \leq 2 \left(\frac{r+q}{r-q} \right)^{1/r} \|\xi\|_{3rq/(r-q)} \cdot c_{q,X}^\xi,$$

so in particular (using that $1/(2q) \leq 1/4$)

$$c_{2q,X} \leq 2 \cdot 3^{1/4} \|\xi\|_{6q} \cdot c_{q,X}^\xi.$$

By Theorem 7.2.6 applied with $2q$ in place of q , we have, for all $r > 2q$,

$$\begin{aligned} & \left\| \sum_{n=1}^N \varepsilon_n f_n x_n \right\|_{L^r(S; L^{2q}(\Omega; X))} \\ & \leq c_{2q,X} (2q)^{1/(2q)} \frac{r}{r-2q} \max_{1 \leq n \leq N} \|f_n\|_{L^r(S)} \left\| \sum_{n=1}^N \varepsilon_n x_n \right\|_{L^{2q}(\Omega; X)}. \end{aligned}$$

Hence with, say, $r = kq$ with $k > 2$, and using that $(2q)^{1/(2q)} \leq \sqrt{2}$ (as $q \geq 2$), we obtain

$$\left\| \sum_{n=1}^N \varepsilon_n f_n x_n \right\|_{L^{kq}(S; L^{2q}(\Omega; X))} \leq c_{2q, X} \frac{k\sqrt{2}}{k-2} \max_{1 \leq n \leq N} \|f_n\|_{kq} \left\| \sum_{n=1}^N \varepsilon_n x_n \right\|_{L^{2q}(\Omega; X)}. \quad (7.18)$$

By randomisation and taking $k = 6$, we obtain

$$\begin{aligned} \left\| \sum_{n=1}^N \xi_n x_n \right\|_{L^q(\Omega'; X)} &= \left\| \sum_{n=1}^N \varepsilon_n |\xi_n| x_n \right\|_{L^q(\Omega \times \Omega'; X)} \\ &\leq \left\| \sum_{n=1}^N \varepsilon_n |\xi_n| x_n \right\|_{L^{6q}(\Omega'; L^{2q}(\Omega; X))} \\ &\leq \frac{6\sqrt{2}}{4} c_{q, X} \cdot \|\xi\|_{6q} \cdot \left\| \sum_{n=1}^N \varepsilon_n x_n \right\|_{L^{2q}(\Omega; X)} \\ &\leq \frac{6\sqrt{2}}{4} \cdot 2 \cdot 3^{1/4} c_{q, X}^\xi \cdot \|\xi\|_{6q}^2 \cdot \left\| \sum_{n=1}^N \varepsilon_n x_n \right\|_{L^{2q}(\Omega; X)} \\ &\leq 24 \cdot \|\xi\|_{6q}^2 \cdot c_{q, X}^\xi \left\| \sum_{n=1}^N \varepsilon_n x_n \right\|_{L^q(\Omega; X)}, \end{aligned}$$

using the Khintchine–Kahane inequality along with the observation that $\kappa_{2q, q} \leq \frac{\pi^2}{4} \sqrt{(2q-1)/(q-1)} \leq \frac{1}{4} \pi^2 \sqrt{3}$ for $q \geq 2$.

For the alternative bound, we make the following splitting relative to a parameter $t > 0$:

$$\begin{aligned} \left\| \sum_{n=1}^N \xi_n x_n \right\|_{L^q(\Omega'; X)} &= \left\| \sum_{n=1}^N \varepsilon_n |\xi_n| x_n \right\|_{L^q(\Omega' \times \Omega; X)} \\ &= \left\| \sum_{n=1}^N \varepsilon_n (|\xi_n| \wedge t + (|\xi_n| - t)_+) x_n \right\|_{L^q(\Omega' \times \Omega; X)} \\ &\leq t \left\| \sum_{n=1}^N \varepsilon_n x_n \right\|_{L^q(\Omega; X)} + \left\| \sum_{n=1}^N \varepsilon_n (|\xi_n| - t)_+ x_n \right\|_{L^{4q}(\Omega'; L^{2q}(\Omega; X))}, \end{aligned}$$

where the first term was simply estimated by the contraction principle. In the second term, we apply (7.18) with $f_n = (|\xi_n| - t)_+$ with $k = 4$ to deduce that

$$\begin{aligned} &\left\| \sum_{n=1}^N \varepsilon_n (|\xi_n| - t)_+ x_n \right\|_{L^{4q}(\Omega'; L^{2q}(\Omega; X))} \\ &\leq 2\sqrt{2} \cdot c_{2q, X} \|(|\xi| - t)_+\|_{4q} \left\| \sum_{n=1}^N \varepsilon_n x_n \right\|_{L^{2q}(\Omega; X)} \\ &\leq 32 c_{q, X}^\xi \|\xi\|_{6q} \|(|\xi| - t)_+\|_{4q} \left\| \sum_{n=1}^N \varepsilon_n x_n \right\|_{L^q(\Omega; X)}, \end{aligned}$$

using the Khintchine–Kahane inequality as before. We also estimate

$$\begin{aligned}
\|(|\xi| - t)_+\|_{4q}^{4q} &= \int_t^\infty 4q(\lambda - t)^{4q-1} \mathbb{P}'(|\xi| > \lambda) \, d\lambda \\
&\leq \int_t^\infty 4q\lambda^{4q-1} \mathbb{P}'(|\xi| > \lambda) \, d\lambda \\
&\leq \int_t^\infty 4q\lambda^{4q-1} \frac{\|\xi\|_u^u}{\lambda^u} \, d\lambda \\
&= \frac{4q}{u-4q} t^{4q-u} \|\xi\|_u^u \leq t^{4q-u} \|\xi\|_u^u,
\end{aligned}$$

if $u \geq 8q$. Putting everything together, we have shown that

$$\begin{aligned}
\left\| \sum_{n=1}^N \xi_n x_n \right\|_{L^q(\Omega'; X)} &\leq t \left(1 + 32c_{q,X}^\xi \|\xi\|_{6q} \cdot \|\xi\|_u^{u/4q} t^{-u/4q} \right) \left\| \sum_{n=1}^N \varepsilon_n x_n \right\|_{L^q(\Omega; X)} \\
&= 2(32c_{q,X}^\xi \|\xi\|_{6q})^{4q/u} \|\xi\|_u \left\| \sum_{n=1}^N \varepsilon_n x_n \right\|_{L^q(\Omega; X)} \\
&= 2e \|\xi\|_{4q \log(32c_{q,X}^\xi \|\xi\|_{6q})} \left\| \sum_{n=1}^N \varepsilon_n x_n \right\|_{L^q(\Omega; X)},
\end{aligned}$$

choosing $t = (32\|\xi\|_{6q} \cdot c_{q,X}^\xi)^{4q/u} \|\xi\|_u$ and $u = 4q \log(32\|\xi\|_{6q} \cdot c_{q,X}^\xi)$, which is in the admissible range $u \geq 8q$, since $\|\xi\|_{6q} \cdot c_{q,X}^\xi \geq \|\xi\|_q \cdot c_{q,X}^\xi \geq 1$ (as is immediate from the ξ -cotype inequality with $N = 1$) and $\log 32 > 2$. \square

Corollary 7.2.9 (Cotype versus ξ -cotype). *Let ξ be a non-zero symmetric random variable with finite moments. A Banach space X has cotype q if and only if it has ξ -cotype q , and in this case*

$$\|\xi\|_q c_{q,X}^\xi \leq c_{q,X} \leq A_{q,X}^\xi c_{q,X}^\xi,$$

where $A_{q,X}^\xi$ is as in Proposition 7.2.8.

Proof. The first estimate has already been verified in Proposition 7.1.18. The second one follows from Proposition 7.2.8 by

$$\left(\sum_{n=1}^N \|x_n\|^q \right)^{1/q} \leq c_{q,X}^\xi \left\| \sum_{n=1}^N \xi_n x_n \right\|_{L^q(\Omega; X)} \leq c_{q,X}^\xi A_{q,X}^\xi \left\| \sum_{n=1}^N \varepsilon_n x_n \right\|_{L^q(\Omega; X)}.$$

\square

We conclude this section by formulating the key consequences in the case of Gaussian random variables.

Corollary 7.2.10 (Gaussian sums versus Rademacher sums under finite cotype). *If X has finite (Gaussian) cotype q , then Gaussian and Rademacher sums in X are comparable: for all $p \in (0, \infty)$,*

$$\|\gamma\|_1 \left\| \sum_{n=1}^N \varepsilon_n x_n \right\|_{L^p(\Omega; X)} \leq \left\| \sum_{n=1}^N \gamma_n x_n \right\|_{L^p(\Omega; X)} \leq \kappa_{p,q}^* A_{q,X}^\gamma \left\| \sum_{n=1}^N \varepsilon_n x_n \right\|_{L^p(\Omega; X)},$$

where $\kappa_{p,q}^* := \max\{\kappa_{p,q}, \kappa_{q,p}\} = \kappa_{p,q} \kappa_{q,p}$ and $A_{q,X}^\gamma \leq 12 \sqrt{q \log(80 \sqrt{q} c_{q,X}^\gamma)}$.

We have already seen in Example 6.1.18 that Gaussian and Rademacher sums in c_0 are incomparable, and indeed this space has no finite cotype. In Corollary 7.3.10 we will see that the finite cotype assumption in the above corollary is actually necessary.

Proof. The lower estimate was already checked in Proposition 6.1.15. For $p = q$, the upper estimate is an application of the previous proposition with $\xi = \gamma$; the bound for $A_{q,X}^\gamma$ uses the estimate $\|\gamma\|_p \leq \sqrt{p}$. The case of general p follows from the Khintchine–Kahane inequality for both Gaussian and Rademacher sums,

$$\begin{aligned} \left\| \sum_{n=1}^N \varepsilon_n x_n \right\|_{L^p(\Omega; X)} &\leq \kappa_{p,q} \left\| \sum_{n=1}^N \varepsilon_n x_n \right\|_{L^q(\Omega; X)}, \\ \left\| \sum_{n=1}^N \gamma_n x_n \right\|_{L^q(\Omega; X)} &\leq \kappa_{q,p} \left\| \sum_{n=1}^N \gamma_n x_n \right\|_{L^p(\Omega; X)}. \end{aligned}$$

□

Corollary 7.2.11 (Gaussian cotype q versus cotype q). *A Banach space X has cotype q if and only if it has Gaussian cotype q , and in this case*

$$\|\gamma\|_q c_{q,X}^\gamma \leq c_{q,X} \leq 12 \cdot c_{q,X}^\gamma \cdot \sqrt{q \log(80 \sqrt{q} c_{q,X}^\gamma)}.$$

Proof. The first assertion is just the special case $\xi = \gamma$ of Corollary 7.2.9, with the estimate for $A_{q,X}^\gamma$ taken from the upper estimate just proved. □

7.2.e Finite cotype in Banach lattices

We have seen in Proposition 6.3.3 that, in the usual L^p -spaces, both Rademacher and Gaussian sums reduce to classical square functions. The main result of this subsection is a far-reaching generalisation of this result in the context of Banach lattices. We have just seen in Corollary 7.2.10 that finite cotype is sufficient for the mutual comparability of Rademacher and Gaussian sums. The Khintchine–Maurey inequality, which we prove here, shows that this same cotype condition ensures the comparability of these random sums with square

functions in abstract Banach lattices. A brief presentation of the concepts we need from the theory of Banach lattices can be found in Appendix F, where in particular it is explained how to define $(\sum_{n=1}^N |x_n|^p)^{1/p}$ for $p \in [1, \infty)$ by the Krivine calculus. All spaces in this subsection are over the real scalar field.

We will need the following extension of Khintchine's inequality. Here, and in the rest of this subsection, $(r_n)_{n \geq 1}$ is a real Rademacher sequence.

Lemma 7.2.12. *Let X be a Banach lattice. Then for all $1 \leq p < \infty$ and $x_1, \dots, x_N \in X$,*

$$\frac{1}{\kappa_{2,p}^{\mathbb{R}}} \left(\sum_{n=1}^N |x_n|^2 \right)^{1/2} \leq \left(\mathbb{E} \left| \sum_{n=1}^N r_n x_n \right|^p \right)^{1/p} \leq \kappa_{p,2}^{\mathbb{R}} \left(\sum_{n=1}^N |x_n|^2 \right)^{1/2}.$$

Note that the middle term is well defined by means of the usual lattice operations, since the random variable $\sum_{n=1}^N r_n x_n$ is discrete, i.e.,

$$\left(\mathbb{E} \left| \sum_{n=1}^N r_n x_n \right|^p \right)^{1/p} = \left(2^{-N} \sum_{\epsilon \in \{-1,1\}^N} \left| \sum_{n=1}^N \epsilon_n x_n \right|^p \right)^{1/p}.$$

Proof. Put $x := \sum_{n=1}^N |x_n|$ and let $S : I_x \rightarrow C(K)$ be the lattice isomorphism given by Kakutani's theorem (Theorem F.2.1). Set $f_n := Sx_n$. By Khintchine's inequality,

$$\frac{1}{\kappa_{2,p}^{\mathbb{R}}} \left(\sum_{n=1}^N |f_n|^2 \right)^{1/2} \leq \left(\mathbb{E} \left| \sum_{n=1}^N r_n f_n \right|^p \right)^{1/p} \leq \kappa_{p,2}^{\mathbb{R}} \left(\sum_{n=1}^N |f_n|^2 \right)^{1/2}.$$

Now the result follows if we apply S^{-1} on both sides and use (F.1). \square

Next we generalise the square function estimate for L^q -spaces from Proposition 6.3.3.

Theorem 7.2.13 (Khintchine–Maurey). *Let X be a Banach lattice with finite cotype q . Then for all $x_1, \dots, x_N \in X$,*

$$\frac{1}{\kappa_{2,1}^{\mathbb{R}}} \left\| \left(\sum_{n=1}^N |x_n|^2 \right)^{1/2} \right\| \leq \mathbb{E} \left\| \sum_{n=1}^N r_n x_n \right\| \leq 5\sqrt{q} c_{q,X} \left\| \left(\sum_{n=1}^N |x_n|^2 \right)^{1/2} \right\|. \quad (7.19)$$

The left-hand side inequality holds for any Banach lattice and the constant $\kappa_{2,1}^{\mathbb{R}} = \sqrt{2}$ (see the Notes of Chapter 6). The proof of the right-hand side inequality depends on an application of Pisier's factorisation theorem.

Lemma 7.2.14. *Let X be a Banach lattice with finite cotype q . Then for all $p \in (q, \infty)$ and $x_1, \dots, x_N \in X$ we have*

$$\left(\sum_{n=1}^N \|x_n\|^p \right)^{1/p} \leq \frac{q^{1/q} p}{p-q} c_{q,X} \left\| \left(\sum_{n=1}^N |x_n|^p \right)^{1/p} \right\|.$$

Proof. Without loss of generality we may assume that $x := (\sum_{n=1}^N |x_n|^p)^{1/p}$ has norm 1. Let $S : I_x \rightarrow C(K)$ be the lattice isometry given by Kakutani's Theorem F.2.1. Note that $\|y\| \leq \|y\|_{I_x}$ for all $y \in I_x$, which means that the embedding $E : I_x \rightarrow X$ is contractive. Also note that the vectors x_n are in I_x and satisfy $\|x_n\|_{I_x} \leq \|x\|_{I_x} = 1 = \|x\|$. Since X has cotype q and $ES^{-1} \in \mathcal{L}(C(K), X)$, it follows from Corollary 7.2.5 to Pisier's factorisation theorem that there exists a probability measure ν on K such that

$$\|ES^{-1}f\| \leq \frac{q^{1/q}p}{p-q} c_{q,X} \|f\|_{L^p(\nu)}, \quad f \in C(K).$$

Writing $x_n = ES^{-1}Sx_n =: ES^{-1}f_n$, with $f_n = Sx_n \in C(K)$, we have

$$\begin{aligned} \left(\sum_{n=1}^N \|x_n\|^p \right)^{1/p} &= \left(\sum_{n=1}^N \|ES^{-1}f_n\|^p \right)^{1/p} \\ &\leq \frac{q^{1/q}p}{p-q} c_{q,X} \left(\sum_{n=1}^N \|f_n\|_{L^p(\nu)}^p \right)^{1/p}, \end{aligned}$$

where

$$\begin{aligned} \left(\sum_{n=1}^N \|f_n\|_{L^p(\nu)}^p \right)^{1/p} &= \left\| \left(\sum_{n=1}^N |f_n|^p \right)^{1/p} \right\|_{L^p(\nu)} \leq \left\| \left(\sum_{n=1}^N |f_n|^p \right)^{1/p} \right\|_{C(K)} \\ &= \left\| \left(\sum_{n=1}^N |Sx_n|^p \right)^{1/p} \right\|_{C(K)} \stackrel{\text{(F.1)}}{=} \left\| S \left(\sum_{n=1}^N |x_n|^p \right)^{1/p} \right\|_{C(K)} \\ &= \|Sx\|_{C(K)} = \|x\|_{I_x} = 1 = \|x\| = \left\| \left(\sum_{n=1}^N |x_n|^p \right)^{1/p} \right\|. \end{aligned}$$

□

Proposition 7.2.15. *Let X be a Banach lattice with finite cotype q . Then any simple function $f = \sum_{n=1}^N x_n \mathbf{1}_{A_n} \in L^p(S; X)$ with $p \in (q, \infty)$ satisfies*

$$\|f\|_{L^p(S; X)} \leq \frac{q^{1/q}p}{p-q} c_{q,X} \|f\|_{X(L^p(S))},$$

where the expression on the right is defined as

$$\|f\|_{X(L^p(S))} := \left\| \left(\sum_{n=1}^N \mu(A_n) |x_n|^p \right)^{1/p} \right\|_X.$$

Proof. Applying Lemma 7.2.14 with $\mu(A_n)^{1/p} x_n$ in place of x_n , we have

$$\|f\|_{L^p(S; X)} = \left(\sum_{n=1}^N \mu(A_n) \|x_n\|^p \right)^{1/p}$$

$$\leq \frac{q^{1/q}p}{p-q} c_{q,X} \left\| \left(\sum_{n=1}^N \mu(A_n) |x_n|^p \right)^{1/p} \right\|_X = \frac{q^{1/q}p}{p-q} c_{q,X} \|f\|_{X(L^p(S))}.$$

□

Proof of Theorem 7.2.13. We first prove the left-hand estimate in (7.19). By taking norms on both sides of the first inequality in Lemma 7.2.12 (with $p = 1$) we obtain

$$\left\| \left(\sum_{n=1}^N |x_n|^2 \right)^{1/2} \right\| \leq \kappa_{2,1}^{\mathbb{R}} \left\| \mathbb{E} \left| \sum_{n=1}^N r_n x_n \right| \right\| \leq \kappa_{2,1}^{\mathbb{R}} \mathbb{E} \left\| \sum_{n=1}^N r_n x_n \right\|,$$

where we applied the triangle inequality and the fact that $(r_n)_{n=1}^N$ takes finitely many values, to pull out the expectation. This proves the first inequality in (7.19).

Turning to the right-hand side inequality, let X be of finite cotype q . By Hölder's inequality, Proposition 7.2.15 (applied to $p = 2q$ and the simple function $f = \sum_{n=1}^N r_n x_n$), and Lemma 7.2.12 we obtain

$$\begin{aligned} \mathbb{E} \left\| \sum_{n=1}^N r_n x_n \right\| &\leq \left(\mathbb{E} \left\| \sum_{n=1}^N r_n x_n \right\|^{2q} \right)^{1/2q} \\ &\leq 3c_{q,X} \left\| \left(\mathbb{E} \left| \sum_{n=1}^N r_n x_n \right|^{2q} \right)^{1/2q} \right\| \\ &\leq 3c_{q,X} \kappa_{2q,2}^{\mathbb{R}} \left\| \left(\sum_{n=1}^N |x_n|^2 \right)^{1/2} \right\|, \end{aligned}$$

$$\text{and } 3\kappa_{2q,2}^{\mathbb{R}} \leq 3\sqrt{2q} < 5\sqrt{q}.$$

□

7.3 Geometric characterisations

We now provide geometric descriptions of some of the classes of spaces that were featured prominently in the previous sections. Indeed, we are going to prove that (see Definition 7.3.7 for the terminology used in 2 and 3)

- (1) a Banach space has both type 2 and cotype 2 if and only if it is isomorphic to a Hilbert space;
- (2) a Banach space has non-trivial type if and only if it does not contain the spaces ℓ_N^1 , $N \geq 1$, uniformly;
- (3) a Banach space has finite cotype if and only if it does not contain the spaces ℓ_N^∞ , $N \geq 1$, uniformly.

While type and cotype as such are sometimes referred to as ‘geometric’ properties of a Banach space, the reader will agree that the above characterisations — involving isomorphisms and containments of appropriate subspaces — are geometric in a rather stricter sense of the word.

The equivalence (1) is the content of Kwapien’s Theorem 7.3.1, which we prove in Section 7.3.a. Both (2) and (3) are contained in the Maurey–Pisier Theorem 7.3.8, which we prove in Section 7.3.b.

The two theorems will play a somewhat opposite role in our subsequent analysis. For our purposes, Kwapien’s theorem will often imply a ‘negative’ statement: it will be used to show that certain results can only be true in the context of Hilbert spaces, and never beyond. In contrast, the Maurey–Pisier theorem will be frequently invoked to check that non-trivial type or finite cotype is implied by some other Banach space property (P) — by checking, often straightforwardly, that (P) is incompatible with the containment of ℓ_N^1 or ℓ_N^∞ — and useful implications of type and cotype can then be used as additional tools to achieve stronger theorems under the assumption of (P).

7.3.a Kwapien’s characterisation of type and cotype 2

The main result of this subsection is the following isomorphic characterisation of Hilbert spaces.

Theorem 7.3.1 (Kwapien). *For a Banach space X the following assertions are equivalent:*

- (1) X has type 2 and cotype 2;
- (2) X is isomorphic to a Hilbert space H .

If these equivalent conditions are satisfied, an isomorphism $J : X \rightarrow H$ can be constructed such that

$$\|J\| \|J^{-1}\| \leq \tau_{2,X}^\gamma c_{2,X}^\gamma.$$

This theorem will be obtained from the special case $X = Y$ and $T = I$ of the following factorisation result.

Theorem 7.3.2 (Maurey). *Let X and Y be Banach spaces and let $T \in \mathcal{L}(X, Y)$. If X has type 2 and Y has cotype 2, then there exist a Hilbert space H and operators $R \in \mathcal{L}(X, H)$ and $S \in \mathcal{L}(H, Y)$ such that $T = SR$ and*

$$\|S\| \|R\| \leq \tau_{2,X}^\gamma c_{2,X}^\gamma \|T\|.$$

We need several preliminary results on factorisation of operators.

Proposition 7.3.3. *Let X and Y be Banach spaces, let $T \in \mathcal{L}(X, Y)$, and let $C \geq 0$. The following assertions are equivalent:*

- (1) *there exists a Hilbert space H and operators $R \in \mathcal{L}(X, H)$ and $S \in \mathcal{L}(H, Y)$ such that $T = SR$ and $\|S\| \|R\| \leq C$.*

(2) for all finite sequences $(x_m)_{m=1}^M$ and $(y_n)_{n=1}^N$ in X such that

$$\sum_{n=1}^N |\langle y_n, x^* \rangle|^2 \leq \sum_{m=1}^M |\langle x_m, x^* \rangle|^2, \quad x^* \in X^*$$

we have

$$\sum_{n=1}^N \|Ty_n\|^2 \leq C^2 \sum_{m=1}^M \|x_m\|^2.$$

This proposition will be proved at the end of the section. Assuming it for the moment, we first show how Theorem 7.3.2 is deduced from it.

Proof of Theorem 7.3.2. Let $(x_m)_{m=1}^M$ and $(y_n)_{n=1}^N$ be sequences in X such that for all $x^* \in X^*$,

$$\sum_{n=1}^N |\langle y_n, x^* \rangle|^2 \leq \sum_{m=1}^M |\langle x_m, x^* \rangle|^2.$$

Let $(\gamma_n)_{n \geq 1}$ be a Gaussian sequence. By Theorem 6.1.25,

$$\begin{aligned} \sum_{n=1}^N \|Ty_n\|^2 &\leq (c_{2,Y}^\gamma)^2 \mathbb{E} \left\| \sum_{n=1}^N \gamma_n Ty_n \right\|^2 \\ &\leq (c_{2,Y}^\gamma)^2 \|T\|^2 \mathbb{E} \left\| \sum_{n=1}^N \gamma_n y_n \right\|^2 \\ &\leq (c_{2,Y}^\gamma)^2 \|T\|^2 \mathbb{E} \left\| \sum_{m=1}^M \gamma_m x_m \right\|^2 \\ &\leq (\tau_{2,X}^\gamma)^2 (c_{2,Y}^\gamma)^2 \|T\|^2 \sum_{m=1}^M \|x_m\|^2. \end{aligned}$$

This verifies condition (2) of Proposition 7.3.3 with $C = \tau_{2,X}^\gamma c_{2,Y}^\gamma \|T\|$. \square

For the proof of Proposition 7.3.3 we need the following lemma.

The *cone* generated by a subset A of a real vector space V is the set

$$\text{cone}(A) = \left\{ \sum_{n=1}^N \alpha_n a_n \in V : \alpha_1, \dots, \alpha_N \geq 0, a_1, \dots, a_N \in A, N \geq 1 \right\}.$$

Lemma 7.3.4. *Let V be a real vector space. Let $A, B \subseteq V$ be non-empty subsets such that $V = \text{cone}(A) - \text{cone}(B)$ and let $f : A \rightarrow \mathbb{R}$, $g : B \rightarrow \mathbb{R}$ be given functions. Then the following assertions are equivalent:*

- (1) *there exists a linear functional $\Phi : V \rightarrow \mathbb{R}$ such that for all $a \in A$, $f(a) \leq \Phi(a)$, and for all $b \in B$, $g(b) \geq \Phi(b)$.*

(2) whenever $(\alpha_n)_{n=1}^N$ and $(\beta_m)_{m=1}^M$ are two finite sequences of non-negative scalars, and $(a_n)_{n=1}^N$ in A and $(b_m)_{m=1}^M$ in B are such that $\sum_{n=1}^N \alpha_n a_n = \sum_{m=1}^M \beta_m b_m$, then

$$\sum_{n=1}^N \alpha_n f(a_n) \leq \sum_{m=1}^M \beta_m g(b_m).$$

Proof. (1) \Rightarrow (2): This follows from

$$\begin{aligned} \sum_{n=1}^N \alpha_n f(a_n) &\leq \sum_{n=1}^N \alpha_n \Phi(a_n) = \Phi\left(\sum_{n=1}^N \alpha_n a_n\right) \\ &= \Phi\left(\sum_{m=1}^M \beta_m b_m\right) = \sum_{m=1}^M \beta_m \Phi(b_m) \leq \sum_{m=1}^M \beta_m g(b_m). \end{aligned}$$

(2) \Rightarrow (1): Define $p : V \rightarrow [-\infty, \infty)$ by

$$p(v) = \inf \left\{ \sum_{m=1}^M \beta_m g(b_m) - \sum_{n=1}^N \alpha_n f(a_n) \right\},$$

where the infimum is taken over all non-negative sequences $(\alpha_n)_{n=1}^N$ and $(\beta_m)_{m=1}^M$ and all sequences $(a_n)_{n=1}^N$ in A and $(b_m)_{m=1}^M$ in B such that $v = \sum_{m=1}^M \beta_m b_m - \sum_{n=1}^N \alpha_n a_n$. Since $V = \text{cone}(A) - \text{cone}(B)$, p is well defined. Moreover, one easily checks that for all $v_1, v_2 \in V$, $p(v_1 + v_2) \leq p(v_1) + p(v_2)$, and for all $v \in V$ and $\lambda > 0$, $p(\lambda v) = \lambda p(v)$. We also claim that $p(0) = 0$. Indeed, $p(0) \leq 0$ is clear from $0 = 0b - 0a$ for $a \in A$ and $b \in B$. Let 0 be represented as

$$0 = \sum_{m=1}^M \beta_m b_m - \sum_{n=1}^N \alpha_n a_n.$$

By (2) it follows that

$$\sum_{m=1}^M \beta_m g(b_m) \geq \sum_{n=1}^N \alpha_n f(a_n),$$

so that $p(0) \geq 0$. This proves the claim. Moreover, for all $v \in V$, $0 = p(0) \leq p(v) + p(-v)$, so that $p(v) > -\infty$. This shows that p is a sub-linear functional. By the Hahn–Banach theorem for real vector spaces (Theorem B.1.1) there exists a linear functional $\Phi : V \rightarrow \mathbb{R}$ such that $\Phi(v) \leq p(v)$ for all $v \in V$.

Next we show that for all $v \in A$, $p(-v) \leq -f(v)$. Indeed, fix $b \in B$ arbitrarily. Then the assertion follows from the representation $-v = 0b - 1v$. Similarly, for all $v \in B$, $p(v) \leq g(v)$.

We conclude that for all $a \in A$, $-f(a) = \Phi(-a) \leq p(-a) \leq -f(a)$, so $f(a) \leq \Phi(a)$. Similarly, for all $b \in B$, $\Phi(b) \leq p(b) \leq g(b)$. \square

Proof of Proposition 7.3.3. (1) \Rightarrow (2): Let $(x_m)_{m=1}^M$ and $(y_n)_{n=1}^N$ be sequences in X be such that for all $x^* \in X^*$,

$$\sum_{n=1}^N |\langle y_n, x^* \rangle|^2 \leq \sum_{m=1}^M |\langle x_m, x^* \rangle|^2.$$

Let $u_m = Rx_m$ and $v_n = Ry_n$. For $h \in H$ let $h^* \in H^*$ be defined as $h^*(h') := \langle h', h \rangle$, where $\langle \cdot | \cdot \rangle$ is the inner product of H . Then, for all $h \in H$,

$$\begin{aligned} \sum_{n=1}^N |(v_n|h)|^2 &= \sum_{n=1}^N |\langle v_n, h^* \rangle|^2 = \sum_{n=1}^N |\langle y_n, R^*h^* \rangle|^2 \\ &\leq \sum_{m=1}^M |\langle x_m, R^*h^* \rangle|^2 = \sum_{m=1}^M |\langle u_m, h^* \rangle|^2 = \sum_{m=1}^M |(u_m|h)|^2. \end{aligned} \quad (7.20)$$

Let $(h_j)_{j=1}^k$ be an orthonormal basis for the subspace spanned in H by the vectors $(u_m)_{m=1}^M$ and $(v_n)_{n=1}^N$. By (7.20),

$$\begin{aligned} \sum_{n=1}^N \|v_n\|^2 &= \sum_{n=1}^N \sum_{j=1}^k |(v_n|h_j)|^2 = \sum_{j=1}^k \sum_{n=1}^N |(v_n|h_j)|^2 \\ &\leq \sum_{j=1}^k \sum_{m=1}^M |(u_m|h_j)|^2 = \sum_{m=1}^M \|u_m\|^2. \end{aligned}$$

Therefore,

$$\sum_{n=1}^N \|Ty_n\|^2 \leq \|S\|^2 \sum_{n=1}^N \|v_n\|_H^2 \leq \|S\|^2 \sum_{m=1}^M \|u_m\|^2 \leq \|S\|^2 \|R\|^2 \sum_{m=1}^M \|x_m\|^2.$$

(2) \Rightarrow (1): First we consider the case $\mathbb{K} = \mathbb{R}$. Let $\mathcal{F}(X^*)$ be the real vector space of all functions $f : X^* \rightarrow \mathbb{R}$. With each $x \in X$, we can associate an element $\hat{x} \in \mathcal{F}(X^*)$ by setting $\hat{x}(x^*) = \langle x, x^* \rangle$. Let \mathcal{V} be the subspace of all $f \in \mathcal{F}(X^*)$ that can be written as a finite sum of the form $f = \sum_{n=1}^N \lambda_n \hat{x}_n \hat{y}_n$ with $x_n, y_n \in X$ and $\lambda_n \in \mathbb{R}$ for all $1 \leq n \leq N$.

Let $A = B = \{\hat{x}^2 \in \mathcal{V} : x \in X\}$. We claim that $\mathcal{V} = \text{cone}(B) - \text{cone}(A)$. Indeed, by linearity of \mathcal{V} it suffices to consider $\phi = \lambda \hat{x} \hat{y} \in \mathcal{V}$, where $\lambda \in \mathbb{R}$ and $x, y \in X$ are arbitrary. Then

$$\phi = \frac{1}{4} \lambda ((\hat{x} + \hat{y})^2 - (\hat{x} - \hat{y})^2)$$

defines an element in $\text{cone}(B) - \text{cone}(A)$ and the claim follows.

Let $f : A \rightarrow \mathbb{R}$ be given by $f(\hat{x}^2) = \|Tx\|^2$ and let $g : B \rightarrow \mathbb{R}$ be given by $g(\hat{x}^2) = C^2 \|x\|^2$, where C is as in the statement of the result. If

$$\sum_{n=1}^N \alpha_n^2 \widehat{y}_n^2 = \sum_{m=1}^M \beta_m^2 \widehat{x}_m^2$$

for some sequences of positive scalars $(\alpha_n)_{n=1}^N$ and $(\beta_m)_{m=1}^M$, then by the assumption of (2),

$$\sum_{n=1}^N \|T(\alpha_n y_n)\|^2 \leq C^2 \sum_{m=1}^M \|\beta_m x_m\|^2$$

and therefore,

$$\sum_{n=1}^N \alpha_n^2 f(\widehat{y}_n) \leq \sum_{m=1}^M \beta_m^2 g(\widehat{x}_m).$$

By Lemma 7.3.4, there exists a linear functional $\Phi : \mathcal{V} \rightarrow \mathbb{R}$ such that

$$\|Tx\|^2 = f(\widehat{x}^2) \leq \Phi(\widehat{x}^2) \leq g(\widehat{x}^2) = C^2 \|x\|^2$$

for all $x \in X$. Define a bilinear form on X by $(x, y) := \Phi(\widehat{x}\widehat{y})$ and consider the seminorm $p(x) := (x, x)^{1/2}$. Let $\mathcal{N} = \{x \in X : p(x) = 0\}$ and consider the real vector space $X_0 = X/\mathcal{N}$. Let H be the completion of X_0 with respect to the norm $p(\cdot)$. Then the induced bilinear form on X_0 has a unique continuous extension to H . This turns H into a real Hilbert space.

Let $R : X \rightarrow H$ be given $Rx = x \bmod(\mathcal{N})$. Then $\|Rx\| = p(x) \leq C\|x\|$ for all $x \in X$. Let $S_0 : X_0 \rightarrow X$ be given by $S_0(Rx) = Tx$. Then $\|S_0(Rx)\| = \|Tx\| \leq p(x) = \|Rx\|_H$. Therefore, S_0 is well defined and has a unique continuous extension to an operator $S \in \mathcal{L}(H, X)$ with $\|S\| \leq 1$. Now $T = SR$ is the required factorisation.

Next we turn to the case $\mathbb{K} = \mathbb{C}$, which will be reduced to the real case by forgetting the complex structure of X . Let $X_{\mathbb{R}}$ be the real Banach space thus obtained and let $X_{\mathbb{R}}^*$ denote its (real) dual. In order not to overburden the notation, the element in $X_{\mathbb{R}}$ corresponding to an $x \in X$ will also be denoted by x .

Let $(x_m)_{m=1}^M$ and $(y_n)_{n=1}^N$ be sequences in X such that in $X_{\mathbb{R}}$ we have

$$\sum_{n=1}^N |\langle y_n, x_{\mathbb{R}}^* \rangle|^2 \leq \sum_{m=1}^M |\langle x_m, x_{\mathbb{R}}^* \rangle|^2 \quad (7.21)$$

for all $x_{\mathbb{R}}^* \in X_{\mathbb{R}}^*$. We claim that

$$\sum_{n=1}^N \|Ty_n\|^2 \leq C^2 \sum_{m=1}^M \|x_m\|^2. \quad (7.22)$$

Indeed, let $x^* \in X^*$ be arbitrary. Let $x_{\mathbb{R}}^*, y_{\mathbb{R}}^* \in X_{\mathbb{R}}^*$ be defined by $\langle x, x_{\mathbb{R}}^* \rangle = \Re \langle x, x^* \rangle$ and $\langle x, y_{\mathbb{R}}^* \rangle = \Im \langle x, x^* \rangle$. Then $x^* = x_{\mathbb{R}}^* + iy_{\mathbb{R}}^*$. Therefore, by (7.21), applied to $x_{\mathbb{R}}^*$ and $y_{\mathbb{R}}^*$, we find

$$\begin{aligned} \sum_{n=1}^N |\langle y_n, x^* \rangle|^2 &= \sum_{n=1}^N |\langle y_n, x_{\mathbb{R}}^* \rangle|^2 + |\langle y_n, y_{\mathbb{R}}^* \rangle|^2 \\ &\leq \sum_{m=1}^M |\langle x_m, x_{\mathbb{R}}^* \rangle|^2 + \sum_{m=1}^M |\langle x_m, y_{\mathbb{R}}^* \rangle|^2 = \sum_{m=1}^M |\langle x_m, x^* \rangle|^2. \end{aligned}$$

Since $x^* \in X^*$ was arbitrary, the assumption in Proposition 7.3.3 gives (7.22) and the claim is proved.

Let (\cdot, \cdot) be the symmetric bilinear form on $X_{\mathbb{R}}$ that was constructed in first part of the proof. We use it to define a sesquilinear form $[\cdot, \cdot]$ on X by

$$[x, y] := \frac{1}{2\pi} \int_0^{2\pi} (e^{i\theta} x, e^{i\theta} y) - i(e^{i\theta} x, e^{i\theta} y) d\theta.$$

Linearity in the first variable is clear. To prove conjugate-linearity in the second variable, the reader may verify that the substitution $\theta' = \theta + \frac{1}{2}\pi$ proves the identity $[x, iy] = -i[x, y]$.

Set $p(x) := [x, x]^{1/2}$. Then p is real-valued and defines a seminorm on X . Moreover,

$$\begin{aligned} |p(x)|^2 &= \Re |p(x)|^2 = \frac{1}{2\pi} \int_0^{2\pi} (e^{i\theta} x, e^{i\theta} x) d\theta \\ &\leq \frac{1}{2\pi} \int_0^{2\pi} C^2 \|e^{i\theta} x\|^2 d\theta = C^2 \|x\|^2. \end{aligned}$$

Let \mathcal{N} and X_0 be as before and let H again be the completion of X_0 with respect to the norm $p(\cdot)$. Then the sesquilinear form has a unique continuous extension to H . In this way H becomes a complex Hilbert space and the proof can be finished as in the real case. \square

As an application we will prove the following isomorphic characterisation of Hilbert spaces. For the definition and properties of Fourier type p we refer to Section 2.4.b.

Theorem 7.3.5 (Kwapień). *For a Banach space X the following assertions are equivalent:*

- (1) X has Fourier type 2;
- (2) there exists a constant $C \geq 0$ such that for all finite sequences $(x_k)_{|k| \leq n}$ in X ,

$$\left\| \sum_{|k| \leq n} e_k x_k \right\|_{L^2(\mathbb{T}; X)} \leq C \left(\sum_{|k| \leq n} \|x_k\|^2 \right)^{1/2};$$

- (3) there exists a constant $\tilde{C} \geq 0$ such that for all finite sequences $(x_k)_{|k| \leq n}$ in X ,

$$\left(\sum_{|k| \leq n} \|x_k\|^2 \right)^{1/2} \leq \tilde{C} \left\| \sum_{|k| \leq n} e_k x_k \right\|_{L^2(\mathbb{T}; X)};$$

(4) X is isomorphic to a Hilbert space H .

If these equivalent conditions are satisfied, then

$$\tau_{2,X} \leq \varphi_{2,X}(\mathbb{Z}) \leq \tilde{C}, \quad c_{2,X} \leq \varphi_{2,X}(\mathbb{T}) \leq C,$$

and the isomorphism $J : X \rightarrow H$ in (4) can be taken such that

$$\|J\| \|J^{-1}\| \leq \tau_{2,X}^\gamma c_{2,X}^\gamma.$$

The equivalences (1) \Leftrightarrow (2) \Leftrightarrow (3) have already been proved in Proposition 2.4.20. Moreover, the best constants in (2) and (3) are equal to the Fourier type 2 constants $\varphi_{2,X}(\mathbb{T})$ and $\varphi_{2,X}(\mathbb{Z})$, respectively. The implication (4) \Rightarrow (1) has already been noted at the beginning of this section. It remains to prove the implication (1) \Rightarrow (4). This will be done by showing that X has type 2 and cotype 2 and then appealing to Kwapien’s isomorphic characterisation of Hilbert spaces (Theorem 7.3.1); this will also produce the estimate for $\|J\| \|J^{-1}\|$.

In fact we have the following general result.

Proposition 7.3.6. *Let X be a Banach space, and let $p \in [1, 2]$ and $p' \in [2, \infty]$ satisfy $\frac{1}{p} + \frac{1}{p'} = 1$. If X has Fourier type p , then X has type p and cotype p' , with constants*

$$\tau_{p,X} \leq \varphi_{p,X}(\mathbb{Z}), \quad c_{p,X} \leq \varphi_{p,X}(\mathbb{T}),$$

with $\varphi_{p,X}(\mathbb{T})$ and $\varphi_{p,X}(\mathbb{Z})$ the operator norms of the Fourier transform from $L^p(\mathbb{T}; X)$ into $\ell^{p'}(\mathbb{Z}; X)$ and from $\ell^p(\mathbb{Z}; X)$ into $L^p(\mathbb{T}; X)$, respectively.

Proof. We may assume that $p \in (1, 2]$ and $p' \in [2, \infty)$, the case $p = 1$ and $p' = \infty$ being trivial.

We use the equivalent formulations of Fourier type as given by Proposition 2.4.20 and recall the notation $e_k(t) := e^{2\pi i kt}$ for $k \in \mathbb{Z}$ and $t \in \mathbb{T}$. Fix a sequence $(x_j)_{j=1}^N$ in X . Since for fixed $t \in \mathbb{T}$, $(\varepsilon_j)_{j=1}^n$ and $(e_j(t)\varepsilon_j)_{j=1}^n$ are identically distributed Rademacher sequences, by averaging over \mathbb{T} and Fubini’s theorem we obtain

$$\begin{aligned} \left\| \sum_{j=1}^N \varepsilon_j x_j \right\|_{L^{p'}(\Omega; X)} &= \left(\int_{\mathbb{T}} \left\| \sum_{j=1}^N \varepsilon_j e_j(t) x_j \right\|_{L^{p'}(\Omega; X)}^{p'} dt \right)^{1/p'} \\ &= \left(\int_{\Omega} \left\| \sum_{j=1}^N \varepsilon_j e_j(t) x_j \right\|_{L^{p'}(\mathbb{T}; X)}^{p'} d\mathbb{P} \right)^{1/p'} \\ &\leq \varphi_{p,X}(\mathbb{Z}) \left(\sum_{j=1}^N \|x_j\|^p \right)^{1/p}. \end{aligned}$$

Thus X has type p with $\tau_{p,X} \leq \varphi_{p,X}(\mathbb{Z})$.

Similarly,

$$\begin{aligned}
\left(\sum_{j=1}^N \|x_j\|^{p'}\right)^{1/p'} &\leq \varphi_{p,X}(\mathbb{T}) \left(\int_{\Omega} \left\| \sum_{j=1}^N \varepsilon_j e_j(t) x_j \right\|_{L^{p'}(\mathbb{T};X)}^{p'} d\mathbb{P}\right)^{1/p'} \\
&= \varphi_{p,X}(\mathbb{T}) \left(\int_{\mathbb{T}} \left\| \sum_{j=1}^N \varepsilon_j e_j(t) x_j \right\|_{L^{p'}(\Omega;X)}^{p'} dt\right)^{1/p'} \\
&= \varphi_{p,X}(\mathbb{T}) \left\| \sum_{j=1}^N \varepsilon_j x_j \right\|_{L^p(\Omega;X)}.
\end{aligned}$$

Thus X has cotype p' with $c_{p',X} \leq \varphi_{p,X}(\mathbb{T})$. \square

Proof of Theorem 7.3.5. If X has Fourier type 2, then by Proposition 7.3.6 X has type 2 and cotype 2 with $\tau_{2,X} \leq \varphi_{2,X}(\mathbb{Z})$ and $c_{2,X} \leq \varphi_{2,X}(\mathbb{T})$. Hence by Theorem 7.3.1, X is isomorphic to a Hilbert space and an isomorphism $J: X \rightarrow H$ may be constructed such that $\|J\| \|J^{-1}\| \leq \tau_{2,X}^\gamma c_{2,X}^\gamma$. \square

7.3.b Maurey–Pisier characterisation of non-trivial (co)type

Among the deepest results in the theory of type and cotype is the celebrated Maurey–Pisier theorem. We will only need the special case which provides a characterisation of non-trivial type and finite cotype in terms of the following notion:

Definition 7.3.7 (Uniform containment of ℓ_N^p). Let X be a Banach space, $p \in [1, \infty]$, and let $\lambda \geq 1$ be a constant. We say X contains the spaces ℓ_N^p λ -uniformly if $\ell_N^1 \subseteq_\lambda X$, i.e., X contains a λ -isomorphic copy of ℓ_N^p in the sense of Definition 7.1.8 for every $N \geq 1$.

We say that X contains the spaces ℓ_N^p uniformly if X contains the spaces ℓ_N^p λ -uniformly for some $\lambda \geq 1$.

Theorem 7.3.8 (Maurey–Pisier). Let X be a Banach space.

- (1) The following conditions are equivalent:
 - (i) X has non-trivial type;
 - (ii) X does not contain the spaces ℓ_N^1 uniformly;
 - (iii) for any $\lambda > 1$, X does not contain the spaces ℓ_N^1 λ -uniformly.
- (2) The following conditions are equivalent:
 - (i) X has finite cotype;
 - (ii) X does not contain the spaces ℓ_N^∞ uniformly;
 - (iii) for any $\lambda > 1$, X does not contain the spaces ℓ_N^∞ λ -uniformly.

Remark 7.3.9. We shall actually prove the following quantitative statements:

- (a) If X has type $p \in (1, 2]$, then

$$\ell_N^1 \not\subseteq_\lambda X \text{ when } N^{1/p'} > \lambda \tau_{p,X}.$$

(b) If X has cotype $q \in [2, \infty)$, then

$$\ell_N^\infty \not\subseteq_\lambda X \text{ when } N^{1/q} > \lambda c_{q,X}.$$

(c) If $\ell_N^1 \not\subseteq_{1+\varepsilon} X$, then

$$\tau_{p,X} \leq 5 \text{ for all } p \leq 1 + \left(\frac{\varepsilon}{50N}\right)^{N+1}.$$

(d) If $\ell_N^\infty \not\subseteq_{1+\varepsilon} X$, then

$$c_{q,X} \leq 5 \text{ for all } q \geq \left(\frac{50N}{\varepsilon}\right)^{2(N+1)}.$$

Here (a) and (b) prove the (straightforward) implications (i) \Rightarrow (iii) of Theorem 7.3.8, while (c) and (d) correspond to the deepest implications (ii) \Rightarrow (i). The implications (iii) \Rightarrow (ii) are of course trivial.

Proof of (a) and (b). If $\ell_N^1 \subseteq_\lambda X$, then by Proposition 7.1.7 and (7.4),

$$N^{1/p'} = \tau_{p,\ell_N^1} \leq \lambda \tau_{p,X}.$$

Likewise, if $\ell_N^\infty \subseteq_\lambda X$, then by Proposition 7.1.7,

$$N^{1/q} = c_{q,\ell_N^\infty} \leq \lambda c_{q,X}.$$

□

Before going to the more sophisticated proofs of the “(ii) \Rightarrow (i)” statements, we demonstrate the use of the theorem with some important consequences.

Consequences of the Maurey–Pisier theorem

In Corollary 7.2.10 we have seen that Gaussian sums and Rademacher sums are comparable in spaces with finite (Gaussian) cotype. Below we show that finite (Gaussian) cotype is actually necessary for such a comparison result.

Corollary 7.3.10. *Let X be a Banach space and $p \in (0, \infty)$. Assume that there exists a constant $C \geq 0$ such that for all integers $N \geq 1$ and vectors $x_1, \dots, x_N \in X$, we have*

$$\left\| \sum_{n=1}^N \gamma_n x_n \right\|_{L^p(\Omega; X)} \leq C \left\| \sum_{n=1}^N \varepsilon_n x_n \right\|_{L^p(\Omega; X)}.$$

Then X has finite cotype.

Proof. Let $\lambda > 1$. If $\ell_N^\infty \subseteq_\lambda X$, then by Example 6.1.18, we have $C \geq \lambda \sqrt{\log(N)/(2\kappa_{1,p})}$. This clearly cannot hold for all $N \geq 1$, and therefore, X has finite cotype by Theorem 7.3.8. □

Corollary 7.3.11. *If a Banach space X has non-trivial type, then it also has finite cotype.*

This is a qualitative formulation of Theorem 7.1.14, which gave additional quantitative information. The point of reproving the result here is to show how effortlessly this qualitative statement follows from the Maurey–Pisier theorem. Note that a quantitative version could be given even here, using the additional information from Remark 7.3.9; however, the reader can easily check that these bounds would be far inferior to those given in Theorem 7.1.14. The moral of the story is that, while Theorem 7.3.8 is extremely powerful for checking the non-trivial type or finite cotype property of Banach spaces qualitatively, it is not particularly adequate for quantitative considerations.

Proof of Corollary 7.3.11. Let X have non-trivial type. Then by Theorem 7.3.8 there are $N, \lambda > 1$ such that $\ell_N^1 \not\subseteq_\lambda X$. By Example 7.1.9, we have $\ell_N^1 \subseteq_{\sqrt{\lambda}} \ell_M^\infty$ for some $M = M(N, \lambda)$. Then $\ell_M^\infty \not\subseteq_{\sqrt{\lambda}} X$, since otherwise we would run into the contradiction that $\ell_N^1 \subseteq_{\sqrt{\lambda}} \ell_M^\infty \subseteq_{\sqrt{\lambda}} X$ and hence $\ell_N^1 \subseteq_\lambda X$. Thus X has finite cotype, again by Theorem 7.3.8. \square

This method for proving that a Banach space has finite cotype is very robust due to the following universality of the ℓ_N^∞ -spaces:

Lemma 7.3.12. *Let E be a finite-dimensional Banach space. Then for each $\varepsilon > 0$ there exists an N such that the space ℓ_N^∞ contains a $(1 + \varepsilon)$ -isomorphic copy of E .*

Proof. Let $\delta > 0$ be such that $(1 - \delta)^{-1} < 1 + \varepsilon$. Since the closed unit ball B_{E^*} is compact we can find $(x_n^*)_{n=1}^N$ in B_{E^*} such that for all $x^* \in B_{E^*}$, one has $\min_{1 \leq n \leq N} \|x^* - x_n^*\| < \delta$. Let $T : E \rightarrow \ell_N^\infty$ be defined by $Tx = (\langle x, x_n^* \rangle)_{n=1}^N$. Let $x \in E$ be arbitrary. It is clear that $\|Tx\| = \max_{1 \leq n \leq N} |\langle x, x_n^* \rangle| \leq \|x\|$. To estimate $\|Tx\|$ from below, using the Hahn–Banach theorem we pick an $x^* \in B_{E^*}$ such that $\langle x, x^* \rangle = \|x\|$. Let $1 \leq k \leq N$ be such that $\|x^* - x_k^*\| < \delta$. Then

$$\begin{aligned} \|Tx\|_{\ell_N^\infty} &= \max_{1 \leq n \leq N} |\langle x, x_n^* \rangle| \geq |\langle x, x_k^* \rangle| \\ &\geq |\langle x, x^* \rangle| - |\langle x, x^* - x_k^* \rangle| \geq \|x\| - \delta \|x\| = (1 - \delta)\|x\|. \end{aligned}$$

\square

Let (P) be a property of a Banach space defined by a family of sub-properties (P_i) , $i \in \mathcal{I}$, such that X has (P) if and only if it has at least one (P_i) . We say that (P) is

- *local*, if each (P_i) holds for X if and only if it holds for every finite-dimensional subspace of X .

- *stable under isomorphisms*, if there exists a mapping $f : \mathcal{S} \times [1, \infty) \rightarrow \mathcal{S}$ such that, whenever X has (P_i) and \tilde{X} is λ -isomorphic to X (i.e., there exists an isomorphism $J : X \rightarrow \tilde{X}$ with $\|J\|\|J^{-1}\| \leq \lambda$), then \tilde{X} has $(P_{f(i,\lambda)})$.

An easy combination of the definitions shows that if (P) is both local and stable under isomorphisms, whenever X has (P_i) and $Y \subseteq_\lambda X$, then Y has $(P_{f(i,\lambda)})$.

Example 7.3.13. In applications to typical Banach space properties, we take (P) to be the qualitative property, and (P_i) to be “property (P) with constant at most i ”. For instance, if (P) is the property “ X has type p ”, and (P_i) the property “ $\tau_{p,X} \leq i$ ” (for $i \in [1, \infty) =: \mathcal{S}$), then (P) is both local and stable under isomorphisms (with $f(i, \lambda) = \lambda \cdot i$). In contrast, it is *not* true that “ X has (P) if and only if every finite-dimensional subspace has (P) ”; indeed, *every* finite-dimensional space has type p , but not every Banach space has it. On the other hand, the stability under isomorphisms would not be true for a fixed (P_i) ; the constant $\tau_{p,X}$ can certainly increase under an isomorphism. This explains the need for a somewhat complicated definition above.

Corollary 7.3.14. *Let (P) be a local property that is stable under isomorphisms. Suppose that there exists a Banach space Y that does not satisfy (P) . Then every Banach space with (P) has finite cotype.*

Proof. Suppose, for contradiction, that X is a Banach space with (P) and without finite cotype. By Theorem 7.3.8, for every $\lambda > 1$ and $N \geq 1$, we have $\ell_N^\infty \subseteq_\lambda X$. Thus each ℓ_N^∞ has $(P_{f(i,\lambda)})$.

On the other hand, consider any finite-dimensional subspace E of Y . By Lemma 7.3.12, we can find an N such that $E \subseteq_\lambda \ell_N^\infty$. Since ℓ_N^∞ has $(P_{f(i,\lambda)})$, the space E has $(P_{f(f(i,\lambda),\lambda)})$. As this holds for every finite-dimensional subspace $E \subseteq Y$, locality implies that Y has $(P_{f(f(i,\lambda),\lambda)})$. Hence Y has (P) , which is a contradiction. \square

As a final application of the Maurey–Pisier theorem at this point, we give a proof of the following result that was already mentioned in Chapter 4:

Proposition 7.3.15. *Every UMD space has non-trivial type and finite cotype.*

A quantitative statement could be extracted from the proof via the bounds in Remark 7.3.9. We leave this as an exercise, and refer the reader to the Notes for much better estimates available via a different approach.

We recall from Chapter 4 (see Definition 4.2.1) the notation $\beta_{p,X}$ for the UMD constants of a UMD Banach space X .

Proof. Let X be a UMD space and suppose that $\ell_{2^n}^1 \subseteq_\lambda X$. By Proposition 4.2.19 we have $\beta_{2,\ell_{2^n}^1} \geq \frac{1}{2}n$, and hence

$$\beta_{2,X} \geq \frac{1}{\lambda} \beta_{2,\ell_{2^n}^1} \geq \frac{n}{2\lambda}.$$

Thus $n \leq 2\lambda\beta_{2,X}$ and we conclude that $\ell_N^1 \not\subseteq_\lambda X$ for $N \geq 2^{2\lambda\beta_{2,X}+1}$. Theorem 7.3.8 implies that X has non-trivial type.

That X has finite cotype can be derived similarly. Alternatively, via either Corollary 7.3.11 or Corollary 7.3.14, it follows from the fact, just proved, that X has non-trivial type. \square

Proof of the main implications in the Maurey–Pisier theorem

We continue with the more sophisticated proofs of the (ii) \Rightarrow (i) statements of Theorem 7.3.8. In both cases, the proof proceeds through an intermediate notion, which somewhat bridges the gap between the uniform (over sequences of any length) inequalities defining type and cotype, and the behaviour of N -dimensional subspaces for a fixed N .

Definition 7.3.16. For each $N \geq 1$, let $\tau_{2,X}(N)$ be the least constant such that for all $x_1, \dots, x_N \in X$ we have

$$\left\| \sum_{n=1}^N \varepsilon_n x_n \right\|_{L^2(\Omega; X)} \leq \tau_{2,X}(N) \left(\sum_{n=1}^N \|x_n\|^2 \right)^{1/2}.$$

Similarly, let $c_{2,X}(N)$ be the least constant such that for all $x_1, \dots, x_N \in X$ we have

$$\left(\sum_{n=1}^N \|x_n\|^2 \right)^{1/2} \leq c_{2,X}(N) \left\| \sum_{n=1}^N \varepsilon_n x_n \right\|_{L^2(\Omega; X)}.$$

By the Cauchy–Schwarz inequality, it is immediate that

$$1 \leq \tau_{2,X}(N), c_{2,X}(N) \leq \sqrt{N}.$$

These numbers come rather close to characterising the type p and cotype q properties of X :

Lemma 7.3.17. Let X be a Banach space, $p \in (1, 2]$ and $q \in [2, \infty)$. Then

$$\frac{1}{\kappa_{2,p}} \sup_{N \geq 1} \left(N^{1/2-1/p} \tau_{2,X}(N) \right) \leq \tau_{p,X} \leq 2^{1/p} \left\| \left(2^{k(1/2-1/p)} \tau_{2,X}(2^k) \right)_{k=0}^\infty \right\|_{\ell^{p'}},$$

$$\frac{1}{\kappa_{q,2}} \sup_{N \geq 1} \left(N^{1/q-1/2} c_{2,X}(N) \right) \leq c_{q,X} \leq 3^{1/q} \left\| \left(2^{k(1/q-1/2)} c_{2,X}(2^k) \right)_{k=0}^\infty \right\|_{\ell^q}.$$

Proof. The left estimates are straightforward. For instance, the first follows from

$$\left\| \sum_{n=1}^N \varepsilon_n x_n \right\|_{L^2(\Omega; X)} \leq \kappa_{2,p} \left\| \sum_{n=1}^N \varepsilon_n x_n \right\|_{L^p(\Omega; X)}$$

$$\begin{aligned}
&\leq \kappa_{2,p} \tau_{p,X} \left(\sum_{n=1}^N \|x_n\|^p \right)^{1/p} \\
&\leq \kappa_{2,p} \tau_{p,X} N^{1/p-1/2} \left(\sum_{n=1}^N \|x_n\|^2 \right)^{1/2}.
\end{aligned}$$

We leave the other case, which is equally easy, to the reader.

For the converse estimates it is helpful to rearrange the vectors x_n in decreasing order according to their norms, $\|x_1\| \geq \|x_2\| \geq \dots \geq \|x_N\|$, and denote $x_n := 0$ for $n > N$. For such a sequence, we have the estimate

$$\left(\frac{1}{2^k} \sum_{n=2^k}^{2^{k+1}-1} \|x_n\|^b \right)^{1/b} \leq \|x_{2^k}\| \leq \left(\frac{1}{2^{k-1}} \sum_{n=2^{k-1}+1}^{2^k} \|x_n\|^a \right)^{1/a} \quad (7.23)$$

for all $a, b > 0$; multiplying all powers of 2 to the right, this will produce the factor $2^{k(1/b-1/a)} 2^{1/a}$, which gives decay when $b > a$. Now

$$\begin{aligned}
&\left\| \sum_{n=1}^N \varepsilon_n x_n \right\|_{L^p(\Omega; X)} \leq \left\| \sum_{n=1}^N \varepsilon_n x_n \right\|_{L^2(\Omega; X)} \\
&\leq \|x_1\| + \sum_{k=1}^{\infty} \left\| \sum_{n=2^k}^{2^{k+1}-1} \varepsilon_n x_n \right\|_{L^2(\Omega; X)} \\
&\leq \|x_1\| + \sum_{k=1}^{\infty} \tau_{2,X}(2^k) \left(\sum_{n=2^k}^{2^{k+1}-1} \|x_n\|^2 \right)^{1/2} \\
&\stackrel{(7.23)}{\leq} \|x_1\| + \sum_{k=1}^{\infty} \tau_{2,X}(2^k) 2^{k(1/2-1/p)} 2^{1/p} \left(\sum_{n=2^{k-1}+1}^{2^k} \|x_n\|^p \right)^{1/p} \\
&\leq 2^{1/p} \left(1 + \sum_{k=1}^{\infty} [\tau_{2,X}(2^k) 2^{k(1/2-1/p)}]^{p'} \right)^{1/p'} \left(\sum_{n=1}^N \|x_n\|^p \right)^{1/p},
\end{aligned}$$

keeping in mind the convention that $x_n = 0$ if $n > N$. Similarly, using the contraction principle, we have

$$\begin{aligned}
&\sum_{n=1}^N \|x_n\|^q = \|x_1\|^q + \sum_{k=1}^{\infty} \sum_{n=2^k}^{2^{k+1}-1} \|x_n\|^q \\
&\stackrel{(7.23)}{\leq} \|x_1\|^q + \sum_{k=1}^{\infty} [2^{k(1/q-1/2)} 2^{1/2}]^q \left(\sum_{n=2^{k-1}+1}^{2^k} \|x_n\|^2 \right)^{q/2} \\
&\leq \|x_1\|^q + \sum_{k=1}^{\infty} [2^{k(1/q-1/2)} 2^{1/2}]^q c_{2,X}(2^{k-1})^q \left\| \sum_{n=2^{k-1}+1}^{2^k} \varepsilon_n x_n \right\|_{L^2(\Omega; X)}^q
\end{aligned}$$

$$\begin{aligned}
&\leq \left(1 + \sum_{k=1}^{\infty} [2^{(k-1)(1/q-1/2)} 2^{1/q}]^q c_{2,X}(2^{k-1})^q\right) \left\| \sum_{n=1}^N \varepsilon_n x_n \right\|_{L^2(\Omega; X)}^q \\
&\leq 3 \left(\sum_{k=0}^{\infty} [2^{k(1/q-1/2)} c_{2,X}(2^k)]^q \right) \left\| \sum_{n=1}^N \varepsilon_n x_n \right\|_{L^q(\Omega; X)}^q.
\end{aligned}$$

□

The numbers $\tau_{2,X}(N)$ and $c_{2,X}(N)$ enjoy an important algebraic property:

Lemma 7.3.18. *Let X be a Banach space. Then for all $M, N \geq 1$ we have the sub-multiplicative estimates*

$$\begin{aligned}
\tau_{2,X}(MN) &\leq \tau_{2,X}(M)\tau_{2,X}(N), \\
c_{2,X}(MN) &\leq c_{2,X}(M)c_{2,X}(N).
\end{aligned}$$

Proof. Let $(\varepsilon_{mn})_{m,n \geq 1}$ be a doubly indexed Rademacher sequence and $(\varepsilon'_n)_{n \geq 1}$ be another Rademacher sequence, defined on a second probability space (Ω', \mathbb{P}') . Then, for all sequences $(x_{mn})_{m,n=1}^{M,N}$ in X ,

$$\begin{aligned}
\mathbb{E} \left\| \sum_{m=1}^M \sum_{n=1}^N \varepsilon_{mn} x_{mn} \right\|^2 &= \mathbb{E} \mathbb{E}' \left\| \sum_{m=1}^M \varepsilon'_m \sum_{n=1}^N \varepsilon_{mn} x_{mn} \right\|^2 \\
&\leq c_{2,X}(M)^2 \sum_{m=1}^M \mathbb{E} \left\| \sum_{n=1}^N \varepsilon_{mn} x_{mn} \right\|^2 \\
&\leq c_{2,X}(M)^2 c_{2,X}(N)^2 \sum_{m=1}^M \sum_{n=1}^N \|x_{mn}\|^2,
\end{aligned}$$

where we used that $(\varepsilon'_m \varepsilon_{mn})_{m,n \geq 1}$ and $(\varepsilon_{mn})_{m,n \geq 1}$ are identically distributed. This proves the inequality for $\tau_{2,X}(MN)$. The proof of the inequality for $c_{2,X}(MN)$ is similar. □

Lemma 7.3.19. *Let $a : \mathbb{Z}_+ \rightarrow \mathbb{R}_+$ be non-decreasing, sub-multiplicative, and $a(n) \leq n^{1/2}$ for all n .*

If $a(N) < N^{1/2}$ for some N , then in fact $a(N) = N^{1/2-\varepsilon}$ for some $\varepsilon \in (0, \frac{1}{2}]$, and $a(n) \leq \sqrt{2} N^\varepsilon n^{1/2-\varepsilon}$ for all $n \in \mathbb{Z}_+$.

In this case, we have $(2^{k(1/q-1/2)} a(2^k))_{k=0}^\infty \in \ell^q$ for all $q > 1/\varepsilon$, and the ℓ^q -norm is bounded by $2N^\varepsilon$ for $q \geq 2/\varepsilon$.

Proof. Sub-multiplicativity implies $a(n) \leq a(1)a(n)$ and hence $a(1) \geq 1$. Thus $a(N) < N^{1/2}$ can only happen for $N \geq 2$, and in this case the number $a(N) \in [1, N^{1/2})$ can be written in the form $a(N) = N^{1/2-\varepsilon}$ for some $\varepsilon \in (0, \frac{1}{2}]$. For arbitrary $n \in \mathbb{Z}_+$, let $N^k \leq n < N^{k+1}$ and write $m := \lceil n/N^k \rceil$. Then $m \in [1, N]$ and also $m < n/N^k + 1 \leq 2n/N^k$ so that $mN^k \leq 2n$. Thus

$$a(n) \leq a(N^k m) \leq a(N)^k a(m) \leq N^{(1/2-\varepsilon)k} m^{1/2}$$

$$= (N^k m)^{1/2-\varepsilon} m^\varepsilon \leq (2n)^{1/2-\varepsilon} N^\varepsilon \leq \sqrt{2} N^\varepsilon n^{1/2-\varepsilon}$$

and

$$\|(2^{k(1/q-1/2)} a(2^k))_{k=0}^\infty\|_{\ell^q}^q \leq \sum_{k=0}^\infty 2^{k(1-q/2)} 2^{q/2} N^{\varepsilon q} 2^{k(q/2-q\varepsilon)} = \frac{2^{q/2} N^{\varepsilon q}}{1-2^{1-q\varepsilon}}$$

provided that $q > 1/\varepsilon$. If $q \geq 2/\varepsilon$, then the denominator is at least $\frac{1}{2}$ and, taking q th roots, the norm is at most $2^{1/2+1/q} N^\varepsilon \leq 2N^\varepsilon$, since $q > 2$. \square

Proposition 7.3.20. *Let X be a Banach space and let $N \geq 1$ be an integer.*

- (1) X has non-trivial type if and only if $\tau_{2,X}(N) < \sqrt{N}$ for some $N \geq 1$.
- (2) X has finite cotype if and only if $c_{2,X}(N) < \sqrt{N}$ for some $N \geq 1$.

The short proof contains additional quantitative information on the assertions.

Proof. If X has type $p > 1$, then $\tau_{2,X}(N) \leq \kappa_{2,p} \tau_{p,X} N^{1/p-1/2} \leq N^{1/2-\varepsilon}$ for any fixed $0 < \varepsilon < 1 - 1/p$, as soon as N is large enough. Conversely, if $\tau_{2,X}(N) \leq N^{1/2-\varepsilon}$, then Lemma 7.3.19 shows (noting that $1/p' - 1/2 = 1/2 - 1/p$) that $(2^{k(1/2-1/p)} \tau_{2,X}(2^k))_{k=0}^\infty \in \ell^{p'}$ for all $p' > 1/\varepsilon$, and Lemma 7.3.17 implies that $\tau_{p,X}$, being dominated by the mentioned $\ell^{p'}$ -norm, is finite. Quantitatively, if $p' \geq 2/\varepsilon$, then the $\ell^{p'}$ -norm is at most $2N^\varepsilon$, and $\tau_{p,X} \leq 2^{1/p} \cdot 2N^{1/\varepsilon} \leq 4N^\varepsilon$.

For cotype, the argument is completely analogous. In particular, for $q \geq 2/\varepsilon$ we get $c_{q,X} \leq 3^{1/q} \cdot 2N^\varepsilon \leq 4N^\varepsilon$. \square

Now the missing ingredient for the proof of Theorem 7.3.8 is a relation between the numbers $\tau_{2,X}(N)$ (respectively $c_{2,X}(N)$) and the isomorphic containment of ℓ_N^1 (respectively ℓ_N^∞). This is accomplished in the following two lemmas.

Lemma 7.3.21. *Let $N \geq 1$ be an integer. Suppose that for some $\varepsilon \in (0, 1]$ and $0 < \delta \leq (\varepsilon/(20N))^{N+1}$ we have $\tau_{2,X}(N) > \sqrt{(1-\delta)N}$. Then X contains a $(1+\varepsilon)$ -isomorphic copy of ℓ_N^1 .*

In particular, if $\tau_{2,X}(N) = \sqrt{N}$, then X contains a $(1+\varepsilon)$ -isomorphic copy of ℓ_N^1 for every $\varepsilon \in (0, 1]$.

Proof. The conclusion is obvious if $N = 1$, so we assume that $N \geq 2$. By the definition of $\tau_{2,X}(N)$ we can find $(x_n)_{n=1}^N$ in X such that

$$\left(\mathbb{E} \left\| \sum_{n=1}^N \varepsilon_n x_n \right\|^2 \right)^{1/2} \geq (1-\delta)^{1/2} \sqrt{N} \left(\sum_{n=1}^N \|x_n\|^2 \right)^{1/2}. \quad (7.24)$$

By homogeneity we may assume that

$$\left(\sum_{n=1}^N \|x_n\|^2 \right)^{1/2} = \sqrt{N}. \quad (7.25)$$

It follows from (7.24), (7.25), the triangle inequality, and the Cauchy–Schwarz inequality that

$$(1 - \delta)^{1/2}N \leq \left(\mathbb{E} \left\| \sum_{n=1}^N \varepsilon_n x_n \right\|^2 \right)^{1/2} \leq \sum_{n=1}^N \|x_n\| \leq \sqrt{N} \left(\sum_{n=1}^N \|x_n\|^2 \right)^{1/2} = N. \quad (7.26)$$

We will draw several conclusions from (7.26). The first is that the norm of each x_n is close to one. To quantify this, let $a = (\|x_1\|, \dots, \|x_N\|)$ and let $e = (1, \dots, 1)$. We write $b \cdot c$ for the inner product of $b, c \in \mathbb{R}^N$, and $\|b\|_2$ for the Euclidean norm of $b \in \mathbb{R}^N$. Let $b = \frac{a \cdot e}{e \cdot e} e$. Since $(a - b) \cdot b = 0$, it follows from (7.26) that

$$\|a - b\|_2^2 = \|a\|^2 - \|b\|^2 \leq N - (1 - \delta)N = \delta N. \quad (7.27)$$

Moreover, by (7.26), $(1 - \delta)^{1/2} \leq b_n \leq 1$. It follows from (7.27) that $|a_n - b_n| \leq \sqrt{\delta N}$ for all n and this implies that

$$\|x_n\| = a_n \leq b_n + \sqrt{\delta N} \leq 1 + \sqrt{\delta N}, \quad (7.28)$$

and

$$\|x_n\| = a_n \geq b_n - \sqrt{\delta N} \geq (1 - \delta)^{1/2} - \sqrt{\delta N}.$$

Next we prove a lower bound on the size of $\sum_{n=1}^N \alpha_n x_n$ uniformly over $|\alpha_n| = 1$, not just on average. Let us first consider the case of complex scalars. For $\alpha \in (S_{\mathbb{C}})^N$ fixed, let $A := A_\theta := \{\beta \in (S_{\mathbb{C}})^N : |\arg \beta_n - \arg \alpha_n| \leq \theta \text{ for all } n = 1, \dots, N\}$. It follows with (7.26) that we have

$$\begin{aligned} (1 - \delta)N^2 &\leq \mathbb{E} \left\| \sum_{n=1}^N \varepsilon_n x_n \right\|^2 \\ &\leq \mathbb{E} \mathbf{1}_{\varepsilon \in A} \left\| \sum_{n=1}^N \varepsilon_n x_n \right\|^2 + \mathbb{E} \mathbf{1}_{\varepsilon \notin A} \left(\sum_{n=1}^N \|x_n\| \right)^2 \\ &\leq \mathbb{E} \mathbf{1}_{\varepsilon \in A} \left(\left\| \sum_{n=1}^N \alpha_n x_n \right\| + \sum_{n=1}^N |\varepsilon_n - \alpha_n| \|x_n\| \right)^2 + \mathbb{P}(\varepsilon \notin A) N^2 \\ &\leq \mathbb{P}(\varepsilon \in A) \left(\left\| \sum_{n=1}^N \alpha_n x_n \right\| + \theta N \right)^2 + (1 - \mathbb{P}(\varepsilon \in A)) N^2. \end{aligned}$$

Rearranging terms and substituting $\mathbb{P}(\varepsilon \in A) = (\theta/\pi)^N$, this implies that

$$\left\| \sum_{n=1}^N \alpha_n x_n \right\| \geq N \left(\sqrt{1 - \delta \cdot \mathbb{P}(\varepsilon \in A)^{-1}} - \theta \right) \geq N \left(1 - \delta(\pi/\theta)^N - \theta \right).$$

Choosing $\theta = \pi \delta^{1/(N+1)}$, we arrive at

$$\left\| \sum_{n=1}^N \alpha_n x_n \right\| \geq N(1 - (1 + \pi)\delta^{1/(N+1)}). \quad (7.29)$$

In the case of real scalars, we can run the same computation with $\theta = 0$, since the singleton $A = A_0 = \{\alpha\}$ already has a positive probability $\mathbb{P}(\varepsilon \in A) = \mathbb{P}(\varepsilon = \alpha) = 2^{-N}$ in the real case. Now the term involving $|\varepsilon_n - \alpha_n|$ is absent, and we arrive at

$$\left\| \sum_{n=1}^N \alpha_n x_n \right\| \geq N\sqrt{1 - \delta \cdot \mathbb{P}(\varepsilon = \alpha)^{-1}} \geq N(1 - \delta 2^N),$$

which is better than (7.29) for the relevant values of δ .

We will show that X contains a λ -isomorphic copy of ℓ_N^1 for some $\lambda \geq 0$ to be determined shortly. Define a linear mapping $T : \ell_N^1 \rightarrow X$ by $Te_n := x_n$. Consider a sequence $c = (c_n)_{n=1}^N \in \mathbb{K}^N$ and assume without loss of generality that $\sum_{n=1}^N |c_n| = 1$. Then by (7.28),

$$\left\| \sum_{n=1}^N c_n x_n \right\| \leq \sum_{n=1}^N |c_n| \|x_n\| \leq (1 + \sqrt{\delta N}). \quad (7.30)$$

For the lower bound, we write $c_n = \rho_n \alpha_n$ with $\rho_n \geq 0$ and $\alpha_n \in S_{\mathbb{K}}$, where $\sum_{n=1}^N \rho_n = \sum_{n=1}^N |c_n| = 1$.

Noting that

$$\begin{aligned} \left\| \sum_{n=1}^N (\alpha_n - c_n)x_n \right\| &\leq \sum_{n=1}^N |\alpha_n - c_n| \|x_n\| \\ &\leq (1 + \sqrt{\delta N}) \sum_{n=1}^N (1 - \rho_n) = (1 + \sqrt{\delta N})(N - 1), \end{aligned}$$

we find that

$$\begin{aligned} \left\| \sum_{n=1}^N c_n x_n \right\| &\geq \left\| \sum_{n=1}^N \alpha_n x_n \right\| - \left\| \sum_{n=1}^N (\alpha_n - c_n)x_n \right\| \\ &\geq N(1 - (1 + \pi)\delta^{1/(N+1)}) - \sum_{n=1}^N |\alpha_n - c_n| \|x_n\| \\ &\geq N(1 - (1 + \pi)\delta^{1/(N+1)}) - (1 + \sqrt{\delta N})(N - 1) \\ &\geq 1 - N((1 + \pi)\delta^{1/(N+1)} + \sqrt{\delta N}). \end{aligned} \quad (7.31)$$

The two bounds (7.30) and (7.31) prove that the T defined above realises a λ -isomorphic copy of ℓ_N^1 in X with

$$\lambda \leq \frac{1 + \sqrt{\delta N}}{1 - N((1 + \pi)\delta^{1/(N+1)} + \sqrt{\delta N})}$$

$$\stackrel{(i)}{\leq} \frac{1 + N\delta^{1/(N+1)}}{1 - 5N\delta^{1/(N+1)}} \stackrel{(ii)}{\leq} 1 + 20N\delta^{1/(N+1)} \leq 1 + \varepsilon,$$

where in (i) we used $\sqrt{\delta N} \leq \delta^{1/(N+1)}N$ and in (ii) we used $\frac{1+x}{1-5x} \leq 1 + 20x$ for $0 \leq x \leq \frac{1}{20}$ with $x = N\delta^{1/(N+1)}$. \square

Lemma 7.3.22. *Let $N \geq 1$ be an integer. Suppose that for some $\varepsilon \in (0, 1]$ and $0 < \delta \leq (\varepsilon/(20N))^{N+1}$ we have $c_{2,X}(N) > \sqrt{N/(1+\delta)}$. Then X contains a $(1+\varepsilon)$ -isomorphic copy of ℓ_N^∞ .*

In particular, if $c_{2,X}(N) = \sqrt{N}$, then X contains a $(1+\varepsilon)$ -isomorphic copy of ℓ_N^∞ for every $\varepsilon \in (0, 1]$.

Proof. Choose a sequence $(x_n)_{n=1}^N$ in X such that

$$\left(\sum_{n=1}^N \|x_n\|^2 \right)^{1/2} \geq (1+\delta)^{-1/2} N^{1/2} \left(\mathbb{E} \left\| \sum_{n=1}^N \varepsilon_n x_n \right\|^2 \right)^{1/2}. \quad (7.32)$$

By homogeneity we may assume that

$$\left(\sum_{n=1}^N \|x_n\|^2 \right)^{1/2} = \sqrt{N}.$$

By the contraction principle, the Cauchy–Schwarz inequality, and (7.32),

$$1 \leq \max_{1 \leq n \leq N} \|x_n\| \leq \mathbb{E} \left\| \sum_{n=1}^N \varepsilon_n x_n \right\| \leq \left(\mathbb{E} \left\| \sum_{n=1}^N \varepsilon_n x_n \right\|^2 \right)^{1/2} \leq (1+\delta)^{1/2}.$$

Let $m := \mathbb{E} \left\| \sum_{n=1}^N \varepsilon_n x_n \right\|$. Then,

$$\mathbb{E} \left(\left\| \sum_{n=1}^N \varepsilon_n x_n \right\| - m \right)^2 = \mathbb{E} \left\| \sum_{n=1}^N \varepsilon_n x_n \right\|^2 - m^2 \leq (1+\delta) - 1 = \delta.$$

Consider fixed $\theta_1, \dots, \theta_N \in S_{\mathbb{K}}$, let $A = A_\eta := \{\alpha \in (S_{\mathbb{K}})^N : |\arg \alpha_n - \arg \theta_n| \leq \eta \text{ for all } n\}$. Then

$$\begin{aligned} & \mathbb{P}(\varepsilon \in A) \left| \left\| \sum_{n=1}^N \theta_n x_n \right\| - m \right| \\ &= \mathbb{E} \mathbf{1}_{\{\varepsilon \in A\}} \left| \left\| \sum_{n=1}^N [\varepsilon_n + (\theta_n - \varepsilon_n)] x_n \right\| - m \right| \\ &\leq \mathbb{E} \left| \left\| \sum_{n=1}^N \varepsilon_n x_n \right\| - m \right| + \mathbb{E} \mathbf{1}_{\{\varepsilon \in A\}} \sum_{n=1}^N |\theta_n - \varepsilon_n| \|x_n\| \end{aligned}$$

$$\leq \sqrt{\delta} + \mathbb{P}(\varepsilon \in A)\eta \sum_{n=1}^N \|x_n\| \leq \sqrt{\delta} + \mathbb{P}(\varepsilon \in A)\eta N,$$

and hence

$$\left| \left\| \sum_{n=1}^N \theta_n x_n \right\| - m \right| \leq \frac{\sqrt{\delta}}{\mathbb{P}(\varepsilon \in A)} + \eta N = \sqrt{\delta} \left(\frac{\pi}{\eta} \right)^N + \eta N = (1 + \pi N) \delta^{1/(2N+2)},$$

if we choose $\eta = \pi \delta^{1/(2N+2)}$. In the real case, we can run the same computation with $\eta = 0$ and $\mathbb{P}(\varepsilon \in A) = 2^{-N}$ to get the upper bound $\sqrt{\delta} 2^N$, which is better than the above in the relevant parameter range. Since $|m-1| \leq \delta/2$, we further deduce that

$$\left| \left\| \sum_{n=1}^N \theta_n x_n \right\| - 1 \right| \leq 5N \delta^{1/(2N+2)}$$

for all complex signs $\theta_1, \dots, \theta_N \in S_{\mathbb{K}}$.

Let us then consider an arbitrary scalar sequence $c = (c_n)_{n=1}^N$, which we normalise with $\max_n |c_n| = 1$. Since $c \in (B_{\mathbb{K}})^N$ can be written as a convex combination of some $(\theta_n)_{n=1}^N \in S_{\mathbb{K}}^N$, we immediately deduce that

$$\left\| \sum_{n=1}^N c_n x_n \right\| \leq \sup_{\theta_1, \dots, \theta_N \in S_{\mathbb{K}}} \left\| \sum_{n=1}^N \theta_n x_n \right\| \leq 1 + 5N \delta^{1/(2N+2)}.$$

For an inequality in the opposite direction, recall that $\|x_n\| \leq (1 + \delta)^{1/2}$ for all $1 \leq n \leq N$. This also gives the estimate

$$\|x_n\|^2 = N - \sum_{m \neq n} \|x_m\|^2 \geq N - (N-1)(1 + \delta) = 1 + \delta - N\delta \geq (1 - N\delta)^2,$$

using that the assumptions on δ and ε imply $N\delta \leq 1$.

If the index k is chosen such that $|a_k| = \max_n |a_n| = 1$, then by the previous two inequalities,

$$\begin{aligned} 2(1 - N\delta) \leq 2\|c_n x_n\| &\leq \left\| c_k x_k + \sum_{n \neq k} c_n x_n \right\| + \left\| c_k x_k - \sum_{n \neq k} c_n x_n \right\| \\ &\leq \left\| \sum_{n=1}^N c_n x_n \right\| + 1 + 5N \delta^{1/(2N+2)}. \end{aligned}$$

This shows that

$$\left\| \sum_{n=1}^N c_n x_n \right\| \geq 2(1 - N\delta) - 1 - 5N \delta^{1/(2N+2)} \geq 1 - 6N \delta^{1/(2N+2)}.$$

Combination of the upper and lower bounds for $\left\| \sum_{n=1}^N c_n x_n \right\|$ shows that X contains a λ -isomorphic copy of ℓ_N^∞ with

$$\lambda \leq \frac{1 + 5N\delta^{1/(2N+2)}}{1 - 6N\delta^{1/(2N+2)}} \leq 1 + 20N\delta^{1/(2N+2)} \leq 1 + \varepsilon,$$

where both estimates follow by the assumption on δ and ε . \square

We can now complete:

Proof of Theorem 7.3.8 and Remark 7.3.9. It remains to prove the implications “(ii) \Rightarrow (i)”, namely, that the failure of the uniform containment of ℓ_N^1 (respectively ℓ_N^∞) for some $\lambda > 1$ implies some non-trivial type $p > 1$ (respectively, some finite cotype $q < \infty$).

Hence, let $\lambda = 1 + \varepsilon$ be a number for which X does not contain the spaces ℓ_N^1 λ -uniformly. Therefore, there exists an N for which X does not contain a λ -isomorphic copy of ℓ_N^1 . By Lemma 7.3.21, this implies that

$$\tau_{2,X}(N) \leq \sqrt{(1 - \delta)N} < \sqrt{N}, \quad \delta = \left(\frac{\varepsilon}{20N}\right)^{N+1},$$

and hence X has non-trivial type by Proposition 7.3.20. Quantitatively, we have

$$\tau_{2,X}(N) \leq \sqrt{e^{-\delta}N} = N^{1/2 - \delta/2 \log N} \leq N^{1/2 - \eta}, \quad \eta = \left(\frac{\varepsilon}{40N}\right)^{N+1}.$$

By the proof of Proposition 7.3.20, X has type p for all $p' > 1/\eta$, in particular for all $p \leq 1 + \eta$. Moreover, for $p' \geq 2/\eta$, in particular for $p = 1 + \eta/2$, we have

$$\tau_{1+\eta/2,X} \leq 4N^\eta \leq 5.$$

For the case of cotype, we argue similarly. Suppose that X does not contain a $(1 + \varepsilon)$ -isomorphic copy of ℓ_N^∞ . By Lemma 7.3.22, this implies that

$$c_{2,X}(N) \leq \sqrt{\frac{N}{1 + \delta}} < \sqrt{N}, \quad \delta = \left(\frac{\varepsilon}{20N}\right)^{2(N+1)}$$

and hence X has finite cotype by Proposition 7.3.20. Quantitatively, we have

$$c_{2,X}(N) \leq \sqrt{e^{-\delta/2}N} = N^{1/2 - \delta/4 \log N} \leq N^{1/2 - \eta}, \quad \eta = \left(\frac{\varepsilon}{40N}\right)^{2(N+1)}.$$

By the proof of Proposition 7.3.20, X has cotype q for all $q > 1/\eta$. Moreover, for $q = 2/\eta$, we have

$$\tau_{2/\eta,X} \leq 4N^\eta \leq 5.$$

\square

7.4 K -convexity

The dual X^* of a Banach space X with type p has cotype p' , $\frac{1}{p} + \frac{1}{p'}$ (Proposition 7.1.13), but no such duality exists between cotype and type: the space ℓ^1 has cotype 2, but neither its predual c_0 nor its dual ℓ^∞ has non-trivial type (Corollary 7.1.10). The notion of K -convexity was invented to make up for this defect: within the class of K -convex spaces (which is self-dual in the sense that a Banach space X is K -convex if and only if X^* is K -convex) there is a perfect duality between type and cotype.

After having dealt with some generalities in Section 7.4.a, the topic of duality will be taken up in Section 7.4.b, where we prove that in the presence of K -convexity, cotype dualises to type. Then, in Section 7.4.c, we turn to the duality of the spaces $\varepsilon^p(X)$ introduced in Section 6.3 and prove that K -convexity implies $\varepsilon^p(X)^* = \varepsilon^{p'}(X^*)$ with equivalent norms whose constants are bounded by the K -convexity constant of X . We also prove that K -convexity is necessary for this result to be true. In Section 7.4.e we show that K -convexity can be equivalently defined by replacing Rademacher variables by certain other variables, such as Gaussians. In the final Section 7.4.f we prove the basic theorem of Pisier that K -convexity is equivalent to non-trivial type.

7.4.a Definition and basic properties

Let $(\varepsilon_n)_{n \geq 1}$ be a Rademacher sequence on a probability space (Ω, \mathbb{P}) , and let X be a Banach space.

Definition 7.4.1. For $p \in (1, \infty)$ and $N \in \mathbb{Z}_+$, let $K_{p,X}^N$ be the smallest admissible constant in the estimate

$$\left\| \sum_{n=1}^N \varepsilon_n x_n \right\|_{L^p(\Omega; X)} \leq K_{p,X}^N \sup \left\{ \left| \sum_{n=1}^N \langle x_n, x_n^* \rangle \right| : \left\| \sum_{n=1}^N \bar{\varepsilon}_n x_n^* \right\|_{L^{p'}(\Omega; X^*)} \leq 1 \right\},$$

where $x_1, \dots, x_N \in X$ are arbitrary, and the supremum is taken over all $x_1^*, \dots, x_N^* \in X^*$ subject to the stated inequality.

The Banach space X is called K -convex if, for some $p \in (1, \infty)$,

$$K_{p,X} := \sup_{N \geq 1} K_{p,X}^N = \lim_{N \rightarrow \infty} K_{p,X}^N < \infty.$$

It is clear that this definition is independent of the particular choice of the Rademacher sequence $(\varepsilon_n)_{n \geq 1}$. Since $(\bar{\varepsilon}_n)_{n \geq 1}$ is another Rademacher sequence, the conjugation bars could be dropped from the definition; however, the stated form is suggestive of the duality

$$\left| \sum_{n=1}^N \langle x_n, x_n^* \rangle \right| = \left| \mathbb{E} \left\langle \sum_{n=1}^N \varepsilon_n x_n, \sum_{m=1}^N \bar{\varepsilon}_m x_m^* \right\rangle \right|$$

$$\leq \left\| \sum_{n=1}^N \varepsilon_n x_n \right\|_{L^p(\Omega; X)} \left\| \sum_{n=1}^N \bar{\varepsilon}_n x_n^* \right\|_{L^{p'}(\Omega; X^*)},$$

which shows that $K_{p,X}^N \geq 1$.

Example 7.4.2. Every Hilbert space H is K -convex, with $K_{2,H} = 1$, since the orthogonality of the ε_n in $L^2(\Omega)$ implies

$$\left\| \sum_{n=1}^N \varepsilon_n x_n \right\|_{L^2(\Omega; H)}^2 = \sum_{n=1}^N \|x_n\|_H^2, \quad \left\| \sum_{n=1}^N \bar{\varepsilon}_n x_n^* \right\|_{L^2(\Omega; H^*)}^2 = \sum_{n=1}^N \|x_n^*\|_{H^*}^2,$$

and of course we have

$$\left(\sum_{n=1}^N \|x_n\|_H^2 \right)^{1/2} = \sup \left\{ \left| \sum_{n=1}^N \langle x_n, x_n^* \rangle \right| : \left(\sum_{n=1}^N \|x_n^*\|_{H^*}^2 \right)^{1/2} \right\}.$$

The following lemma shows that both the exponent p and the choice of the scalar field are somewhat immaterial for the definition of K -convexity:

Lemma 7.4.3. *Let X be a Banach space. Then for all $p, q \in (1, \infty)$,*

$$K_{p,X}^N \leq \max\{\kappa_{p,q}, \kappa_{p',q'}\} K_{q,X}^N, \\ \frac{4}{\pi^2} K_{p,X_{\mathbb{R}}}^N \leq K_{p,X}^N \leq \frac{\pi^2}{4} K_{p,X_{\mathbb{R}}}^N.$$

Here, $X_{\mathbb{R}}$ is the realification of a complex Banach space X (see Appendix B). When convenient, we may also write $K_{p,X}^{\mathbb{R}} := K_{p,X_{\mathbb{R}}}^N$.

Proof. By two applications of the Kahane–Khintchine inequality (Theorem 6.2.4), with the definition of $K_{q,X}^N$ in between, we have

$$\left\| \sum_{n=1}^N \varepsilon_n x_n \right\|_{L^p(\Omega; X)} \leq \kappa_{p,q} \left\| \sum_{n=1}^N \varepsilon_n x_n \right\|_{L^q(\Omega; X)} \\ \leq \kappa_{p,q} K_{q,X}^N \sup \left\{ \left| \sum_{n=1}^N \langle x_n, x_n^* \rangle \right| : \left\| \sum_{n=1}^N \bar{\varepsilon}_n x_n^* \right\|_{L^{q'}(\Omega; X^*)} \leq 1 \right\} \\ \leq \kappa_{p,q} K_{q,X}^N \sup \left\{ \left| \sum_{n=1}^N \langle x_n, x_n^* \rangle \right| : \left\| \sum_{n=1}^N \bar{\varepsilon}_n x_n^* \right\|_{L^{p'}(\Omega; X^*)} \leq \kappa_{p',q'} \right\},$$

and thus $K_{p,X}^N \leq \kappa_{p,q} \kappa_{p',q'} K_{q,X}^N$, where one of $\kappa_{p,q}$ and $\kappa_{p',q'}$ is always 1.

The proof of the second estimate is entirely similar; instead of comparing L^p and L^q -norms, we compare real and complex Rademacher sums via Proposition 6.1.19. Instead of a product of Khintchine–Kahane constants, this gives the constant $(\pi/2) = \pi^2/4$ in both directions. \square

Definition 7.4.4. For $N = 1, 2, \dots$ and $1 < p < \infty$ the Rademacher projections on $L^p(\Omega; X)$ are defined by

$$\pi_N f := \sum_{n=1}^N \varepsilon_n \mathbb{E}(\bar{\varepsilon}_n f), \quad f \in L^p(\Omega; X).$$

To see that π_N is indeed a projection, note that $\mathbb{E}(\bar{\varepsilon}_n \varepsilon_m) = \delta_{nm}$ and therefore

$$\pi_N(\pi_N f) = \sum_{n=1}^N \varepsilon_n \mathbb{E}(\bar{\varepsilon}_n \sum_{m=1}^N \varepsilon_m \mathbb{E}(\bar{\varepsilon}_m f)) = \sum_{n=1}^N \varepsilon_n \mathbb{E}(\bar{\varepsilon}_n f) = \pi_N f.$$

Proposition 7.4.5. Let X be a Banach space with dual X^* , and let $Y \subseteq X^*$ be a norming subspace for X . Then for all $p \in (1, \infty)$ and $N \in \mathbb{Z}_+$ we have

$$\|\pi_N\|_{\mathcal{L}(L^p(\Omega; X))} = K_{p, X}^N = K_{p', X^*}^N = K_{p', Y}^N.$$

In particular, a Banach space is K -convex if and only if its dual is, and the norm of $\pi_N \in \mathcal{L}(L^p(\Omega; X))$ is also independent of the particular Rademacher sequence appearing in its definition.

This proposition shows that the present Definition 7.4.1 of K -convexity is equal to that of Section 4.3.b in terms of $\sup_{N \geq 1} \|\pi_N\|_{\mathcal{L}(L^p(\Omega; X))}$ (where π_N was defined in terms of the *real* Rademachers r_n) in real Banach spaces, and (by Lemma 7.4.3) equivalent in complex Banach spaces.

Proof. Step 1: We prove that $\|\pi_N\|_{\mathcal{L}(L^p(\Omega; X))} \leq K_{p, X}^N$. Indeed, by definition,

$$\|\pi_N f\|_{L^p(\Omega; X)} \leq K_{p, X}^N \sup \left\{ \left| \sum_{n=1}^N \langle \mathbb{E}(\bar{\varepsilon}_n f), x_n^* \rangle \right| : \left\| \sum_{n=1}^N \bar{\varepsilon}_n x_n^* \right\|_{L^{p'}(\Omega; X^*)} \leq 1 \right\},$$

where

$$\begin{aligned} \left| \sum_{n=1}^N \langle \mathbb{E}(\bar{\varepsilon}_n f), x_n^* \rangle \right| &= \left| \mathbb{E} \left\langle f, \sum_{n=1}^N \bar{\varepsilon}_n x_n^* \right\rangle \right| \\ &\leq \|f\|_{L^p(\Omega; X)} \left\| \sum_{n=1}^N \bar{\varepsilon}_n x_n^* \right\|_{L^{p'}(\Omega; X^*)} \leq \|f\|_{L^p(\Omega; X)}, \end{aligned}$$

and thus $\|\pi_N f\|_{L^p(\Omega; X)} \leq K_{p, X}^N \|f\|_{L^p(\Omega; X)}$.

Step 2: Let us write

$$\bar{\pi}_N g := \sum_{n=1}^N \bar{\varepsilon}_n \mathbb{E}(\varepsilon_n g)$$

for the Rademacher projection defined in terms of the conjugate Rademacher sequence $(\varepsilon_n)_{n \geq 1}$ on $L^{p'}(\Omega; X^*) \subseteq (L^p(\Omega; X))^*$. For $f \in L^p(\Omega; X)$ and $g \in L^{p'}(\Omega; X^*)$, one checks that

$$\langle f, \bar{\pi}_N g \rangle = \mathbb{E} \left\langle f, \sum_{n=1}^N \bar{\varepsilon}_n \mathbb{E}(\varepsilon_n g) \right\rangle = \mathbb{E} \left\langle \sum_{n=1}^N \varepsilon_n \mathbb{E}(\bar{\varepsilon}_n f), g \right\rangle = \langle \pi_N f, g \rangle,$$

and hence $\bar{\pi}_N = \pi_N^*|_{L^{p'}(\Omega; X^*)}$. It follows at once that

$$\|\bar{\pi}_N\|_{\mathcal{L}(L^{p'}(\Omega; Y))} \leq \|\bar{\pi}_N\|_{\mathcal{L}(L^{p'}(\Omega; X^*))} \leq \|\pi_N\|_{\mathcal{L}(L^p(\Omega; X))}.$$

Step 3: We prove that $K_{p, X}^N \leq \|\bar{\pi}_N\|_{\mathcal{L}(L^{p'}(\Omega; Y))}$. Indeed, since $L^{p'}(\Omega; Y)$ is norming for $L^p(\Omega; X)$ (Proposition 1.3.1), we have

$$\left\| \sum_{n=1}^N \varepsilon_n x_n \right\|_{L^p(\Omega; X)} = \sup \left\{ \left| \mathbb{E} \left\langle \sum_{n=1}^N \varepsilon_n x_n, g \right\rangle \right| : \|g\|_{L^{p'}(\Omega; Y)} \leq 1 \right\},$$

where

$$\mathbb{E} \left\langle \sum_{n=1}^N \varepsilon_n x_n, g \right\rangle = \sum_{n=1}^N \langle x_n, \mathbb{E}(\varepsilon_n g) \rangle =: \sum_{n=1}^N \langle x_n, x_n^* \rangle$$

and

$$\left\| \sum_{n=1}^N \bar{\varepsilon}_n x_n^* \right\|_{L^{p'}(\Omega; Y)} = \|\bar{\pi}_N g\|_{L^{p'}(\Omega; Y)} \leq \|\bar{\pi}_N\|_{\mathcal{L}(L^{p'}(\Omega; Y))}.$$

So we have checked that

$$\begin{aligned} & \left\| \sum_{n=1}^N \varepsilon_n x_n \right\|_{L^p(\Omega; X)} \\ & \leq \|\bar{\pi}_N\|_{\mathcal{L}(L^{p'}(\Omega; Y))} \sup \left\{ \left| \sum_{n=1}^N \langle x_n, x_n^* \rangle \right| : \left\| \sum_{n=1}^N \bar{\varepsilon}_n x_n^* \right\|_{L^{p'}(\Omega; Y)} \leq 1 \right\}, \end{aligned} \quad (7.33)$$

and this shows that $K_{p, X} \leq \|\bar{\pi}_N\|_{\mathcal{L}(L^{p'}(\Omega; Y))}$.

Step 4: Conclusion. We have now proved that

$$K_{p, X}^N \leq \|\bar{\pi}_N\|_{\mathcal{L}(L^{p'}(\Omega; Y))} \leq \|\bar{\pi}_N\|_{\mathcal{L}(L^{p'}(\Omega; X^*))} \leq \|\pi_N\|_{\mathcal{L}(L^p(\Omega; X))} \leq K_{p, X}^N,$$

and hence all these quantities are actually equal. In particular, we have $K_{p, X}^N = \|\pi_N\|_{\mathcal{L}(L^p(\Omega; X))}$, which shows that the latter is independent of the choice of the Rademacher sequence, since the former is. Applying this with p' in place of p , with X^* or Y in place of X , and with $(\bar{\varepsilon}_n)_{n \geq 1}$ in place of $(\varepsilon_n)_{n \geq 1}$, we also see that

$$K_{p', X^*}^N = \|\bar{\pi}_N\|_{\mathcal{L}(L^{p'}(\Omega; X^*))}, \quad K_{p', Y}^N = \|\bar{\pi}_N\|_{\mathcal{L}(L^{p'}(\Omega; Y))}.$$

Combining all the equalities, we have proved the Proposition. \square

An intermediate step above is worth isolating as an independent result:

Corollary 7.4.6. *Let X be a Banach space and let $Y \subseteq X^*$ be a closed linear subspace that is norming for X . Then for all $p \in (1, \infty)$, $N \in \mathbb{Z}_+$, and $x_1, \dots, x_N \in X$, we have*

$$\left\| \sum_{n=1}^N \varepsilon_n x_n \right\|_{L^p(\Omega; X)} \leq K_{p, X}^N \sup \left\{ \left| \sum_{n=1}^N \langle x_n, x_n^* \rangle \right| : \left\| \sum_{n=1}^N \bar{\varepsilon}_n x_n^* \right\|_{L^{p'}(\Omega; Y)} \leq 1 \right\},$$

where the supremum is over all $x_1^*, \dots, x_N^* \in Y$ with the specified constraint.

Proof. In (7.33), we proved this with $\|\bar{\pi}_N\|_{\mathcal{L}(L^{p'}(\Omega; Y))}$ in place of $K_{p, X}^N$. But Proposition 7.4.5 informs us that $\|\bar{\pi}_N\|_{\mathcal{L}(L^{p'}(\Omega; Y))} = K_{p', Y}^N = K_{p, X}^N$. \square

Example 7.4.7. Let (S, \mathcal{A}, μ) be a measure space and fix $1 < p < \infty$. If X is K -convex and $1 < p < \infty$, then $L^p(S; X)$ is K -convex and $K_{p, L^p(S; X)} = K_{p, X}$.

This follows readily by Fubini's theorem from the characterisation of K -convexity by the L^p -boundedness of the projections π_N , since π_N on $L^p(\Omega; L^p(S; X)) \simeq L^p(S; L^p(\Omega; X))$ acts pointwise at every $s \in S$ as π_N on $L^p(\Omega; X)$.

In particular, the spaces $L^p(S)$ with $1 < p < \infty$ are K -convex. Estimates for their K -convexity constants can be obtained from Lemma 7.4.3.

We recall from Chapter 4 (see Proposition 4.2.3) the notation $\beta_{p, X}^\pm$ for the one-sided UMD constants of a UMD Banach space X .

Example 7.4.8. Every UMD space X is K -convex, and $K_{p, X}^{\mathbb{R}} \leq \beta_{p, X_{\mathbb{R}}}^+$ for every $p \in (1, \infty)$. This was proved in Proposition 4.3.10, where K -convexity was defined in terms of the real version of the projections π_N only.

Example 7.4.9. If a real Banach space X is K -convex, then the real projections π_N are bounded on $L^p(\Omega; X)$ with constant $K_{p, X}$, and by the triangle inequality, their extensions to $L^p(\Omega; X_{\mathbb{C}})$ are bounded by $2K_{p, X}$, no matter which admissible norm is used on the complexification $X_{\mathbb{C}}$. If $X_{\mathbb{C}}$ is equipped with the particular norm of $X_{\mathbb{C}}^{\gamma, p}$ introduced in Section 2.1.b, then Proposition 2.1.12 even guarantees that the norm is preserved. Thus

$$K_{p, X_{\mathbb{C}}}^{\mathbb{R}} \leq 2K_{p, X}, \quad K_{p, X_{\mathbb{C}}^{\gamma, p}} = K_{p, X},$$

and from Lemma 7.4.3 we conclude that

$$K_{p, X_{\mathbb{C}}} \leq \frac{\pi^2}{2} K_{p, X}, \quad K_{p, X_{\mathbb{C}}^{\gamma, p}} \leq \frac{\pi^2}{4} K_{p, X},$$

where $X_{\mathbb{C}}$ in both estimates is equipped with any admissible norm.

7.4.b K -convexity and type

We begin with the application for which the notion of K -convexity was first invented: the restoration of the missing symmetry in the duality of type and cotype (cf. Proposition 7.1.13 and the preceding discussion).

Proposition 7.4.10. *Let X be a K -convex Banach space. If X has cotype $q \in [2, \infty)$, then X^* has type q' , with $\tau_{q', X^*} \leq c_{q, X} K_{q, X}$.*

Proof. Since $X \subseteq X^{**}$ is norming for X^* , Corollary 7.4.6 guarantees that

$$\left\| \sum_{n=1}^N \varepsilon_n x_n^* \right\|_{L^{q'}(\Omega; X^*)} \leq K_{q', X^*} \sup \left\{ \left| \sum_{n=1}^N \langle x_n, x_n^* \rangle \right| : \left\| \sum_{n=1}^N \bar{\varepsilon}_n x_n \right\|_{L^q(\Omega; X)} \leq 1 \right\},$$

where

$$\left| \sum_{n=1}^N \langle x_n, x_n^* \rangle \right| \leq \left(\sum_{n=1}^N \|x_n\|^q \right)^{1/q} \left(\sum_{n=1}^N \|x_n^*\|^{q'} \right)^{1/q'}$$

and

$$\left(\sum_{n=1}^N \|x_n\|^q \right)^{1/q} \leq c_{q, X} \left\| \sum_{n=1}^N \bar{\varepsilon}_n x_n \right\|_{L^q(\Omega; X)} \leq c_{q, X}.$$

Hence

$$\left\| \sum_{n=1}^N \varepsilon_n x_n^* \right\|_{L^{q'}(\Omega; X^*)} \leq K_{q', X^*} c_{q, X} \left(\sum_{n=1}^N \|x_n^*\|_{X^*}^{q'} \right)^{1/q'},$$

which proves that $\tau_{q', X^*} \leq K_{q', X^*} c_{q, X} = K_{q, X} c_{q, X}$. \square

If we apply the result to X^* (which is also K -convex) in place of X , we see that cotype q of X^* implies type q of X^{**} , and hence of $X \subseteq X^{**}$. Alternatively, in order to get from cotype q of X^* to type q of X , one can run the same argument, even slightly simplified, since in the first step one can directly use the definition of K -convexity of X , instead of Corollary 7.4.6.

While in Proposition 7.4.10 we deduced type from K -convexity and cotype, we next show that K -convexity alone already implies some non-trivial type. This will be accomplished with the help of the Maurey–Pisier Theorem 7.3.8 and the growth of the K -convexity constants of the finite-dimensional ℓ_n^1 -spaces, as quantified in the following:

Lemma 7.4.11. *For all $p \in (1, \infty)$ and integers $N \geq 1$, we have*

$$K_{p, \ell_{2^N}^1} \geq (\kappa_{2,1})^{-1} \sqrt{N},$$

where $\ell_{2^N}^1$ is considered over real scalars.

Proof. Consider the probability space $D_N = \{-1, 1\}^N$ with the uniform probability measure $\mu(\{d\}) = 2^{-N}$, $d \in D_N$. Observe that the coordinate mappings $s_n(d) = d_n$ form a real Rademacher sequence.

Let $f_N : \Omega \rightarrow \ell^1(D_N)$ be defined by

$$f_N := \prod_{n=1}^N (1 + s_n r_n),$$

where $(r_n)_{n=1}^N$ is a real Rademacher sequence defined on a probability space (Ω, \mathbb{P}) . By the independence of the coordinate functions s_n we obtain, writing \mathbb{E}_μ for integration with respect to μ ,

$$\|f_N(\omega)\|_{\ell^1(D_N)} = \prod_{n=1}^N \mathbb{E}_\mu |1 + s_n r_n(\omega)| = \prod_{n=1}^N \mathbb{E}_\mu (1 + s_n r_n(\omega)) = \prod_{n=1}^N 1 = 1$$

for all $\omega \in \Omega$. Therefore, $\|f_N\|_{L^p(\Omega; \ell^1(D_N))} = 1$. On the other hand, for all $1 \leq n \leq N$ we have $\mathbb{E}(r_n f_N) = s_n$, and therefore $\pi_N f_N = \sum_{n=1}^N r_n s_n$. By the Khintchine inequality for the Rademacher sequence $(s_n)_{n=1}^N$ (see (3.34)) we obtain, for all $\omega \in \Omega$,

$$\|\pi_N f_N(\omega)\|_{\ell^1(D_N)} = \mathbb{E}_\mu \left| \sum_{n=1}^N r_n(\omega) s_n \right| \geq \kappa_{2,1}^{-1} \left(\sum_{n=1}^N |r_n(\omega)|^2 \right)^{1/2} = \kappa_{2,1}^{-1} \sqrt{N}.$$

Fixing $p \in (1, \infty)$, it follows that $\|\pi_N\|_{\mathcal{L}(L^p(\Omega; \ell^1(D_N)))} \geq (\kappa_{2,1})^{-1} \sqrt{N}$, and therefore $K_{p, \ell^1(D_N)} \geq (\kappa_{2,1})^{-1} \sqrt{N}$. Since $\ell^1(D_N)$ is isometrically isomorphic to $\ell_{2,N}^1$, this proves the estimate in the first part of the proposition. \square

Proposition 7.4.12. *Every K -convex Banach space has non-trivial type and finite cotype.*

Proof. Let first X be a K -convex real Banach space. Lemma 7.4.11 shows that X cannot contain the real spaces ℓ_N^1 uniformly. Therefore, the Maurey–Pisier Theorem 7.3.8 implies that X has non-trivial type and hence also, by Corollary 7.3.11, finite cotype.

If X is a complex K -convex Banach space, then $X_{\mathbb{R}}$ is K -convex by Lemma 7.4.3, and therefore X has non-trivial type and finite cotype by (7.1). \square

7.4.c K -convexity and duality of the spaces $\varepsilon_N^p(X)$

The purpose of this subsection is to have a closer look at the duality of the random sequence norms suggested by the very Definition 7.4.1. Recall that the spaces $\varepsilon_N^p(X)$, $N \geq 1$, were defined in Section 6.3 as the Banach spaces of sequences $(x_n)_{n=1}^N$ in X endowed with the norm

$$\|(x_n)_{n=1}^N\|_{\varepsilon_N^p(X)} := \left\| \sum_{n=1}^N \varepsilon_n x_n \right\|_{L^p(\Omega; X)}.$$

Likewise the space $\varepsilon^p(X)$ was defined to be the Banach space of sequences $(x_n)_{n \geq 1}$ in X for which the sum $\sum_{n \geq 1} \varepsilon_n x_n$ converges in $L^p(\Omega; X)$, endowed with the norm

$$\|(x_n)_{n \geq 1}\|_{\varepsilon^p(X)} := \left\| \sum_{n \geq 1} \varepsilon_n x_n \right\|_{L^p(\Omega; X)} = \sup_{N \geq 1} \left\| \sum_{n=1}^N \varepsilon_n x_n \right\|_{L^p(\Omega; X)}.$$

Among other things it was shown in Section 6.3 (see Proposition 6.3.4) that for all $p \in [1, \infty)$ one has a natural identification $(\varepsilon_N^p(X))^{**} = \varepsilon_N^p(X^{**})$ for any Banach space X , whereas the description of the first dual $(\varepsilon_N^p(X))^*$ offered there was more complicated.

As suggested by the very Definition 7.4.1, the simpler identification

$$(\varepsilon_N^p(X))^* \simeq \varepsilon_N^{p'}(X^*) \quad (7.34)$$

will be available when $p \in (1, \infty)$ and X is K -convex, and under these assumptions one also has a similar identification of the infinite sequence spaces, $(\varepsilon^p(X))^* \simeq \varepsilon^{p'}(X^*)$. We begin with a preliminary observation about a limit $\pi = \lim_{N \rightarrow \infty} \pi_N$ of the Rademacher projections π_N .

Proposition 7.4.13. *Let X be a K -convex Banach space and let $p \in (1, \infty)$. Then the strong operator limit $\pi := \lim_{n \rightarrow \infty} \pi_n$ exists in $\mathcal{L}(L^p(\Omega; X))$ and defines a projection on $L^p(\Omega; X)$ of norm $\|\pi\| = K_{p,X}$.*

Proof. Let $\mathbb{E}_\infty := \mathbb{E}(\cdot | \mathcal{F}_\infty)$ denote the conditional expectation with respect to the σ -algebra $\mathcal{F}_\infty := \sigma(\varepsilon_n, n \geq 1)$. For all $f \in L^p(\Omega; X)$ and $n \geq 1$ we have $\pi_n f = \pi_n \mathbb{E}_\infty f$, and therefore it suffices to establish the existence of the limit $\lim_{n \rightarrow \infty} \pi_n f$ for functions $f \in L^p(\mathcal{F}_\infty; X)$.

Fix $f \in L^p(\mathcal{F}_\infty; X)$ and $\varepsilon > 0$. Since $\bigcup_{N \geq 1} L^p(\mathcal{F}_N; X)$ (with $\mathcal{F}_N := \sigma(\varepsilon_1, \dots, \varepsilon_N)$) is dense in $L^p(\mathcal{F}_\infty; X)$ (by Lemma A.1.2), there exist $N \geq 1$ and $g \in L^p(\mathcal{F}_N; X)$ such that $\|f - g\|_{L^p(\Omega; X)} < \varepsilon$. For all $k \geq N$, we have $\mathbb{E}(\bar{\varepsilon}_k g) = \mathbb{E} \mathbb{E}_N(\bar{\varepsilon}_k g) = \mathbb{E}(g \mathbb{E}(\bar{\varepsilon}_k)) = 0$. It follows that for all $m, n \geq N$, one has $\pi_n g = \pi_m g$, and hence

$$\begin{aligned} \|\pi_n f - \pi_m f\|_{L^p(\Omega; X)} &\leq \|(\pi_n - \pi_m)(f - g)\|_{L^p(\Omega; X)} + \|\pi_n g - \pi_m g\|_{L^p(\Omega; X)} \\ &\leq 2K_{p,X} \|f - g\|_{L^p(\Omega; X)} + 0 = 2K_{p,X} \varepsilon. \end{aligned}$$

This shows that $(\pi_n f)_{n \geq 1}$ is a Cauchy sequence in $L^p(\Omega; X)$ and therefore it is convergent. The limit $\pi f := \lim_{n \rightarrow \infty} \pi_n f$ defines a bounded operator satisfying $\|\pi\| \leq \limsup_{n \rightarrow \infty} \|\pi_n\| \leq K_{p,X}$. Finally, since $\pi|_{L^p(\mathcal{F}_N)} = \pi_N|_{L^p(\mathcal{F}_N)}$, it follows that $\|\pi\| \geq \|\pi_N\|$ and therefore also $\|\pi\| \geq K_{p,X}$. \square

We now turn to the problem of proving (7.34). Let us start by making some elementary observations. Let $1 \leq p \leq \infty$. Each function $g \in \varepsilon_N^{p'}(X^*)$ defines an element, denoted $j_N(g)$, of $(\varepsilon_N^p(X))^*$ in the following way. Writing $g = \sum_{n=1}^N \varepsilon_n x_n^*$, for each $f = \sum_{n=1}^N \varepsilon_n x_n \in \varepsilon_N^p(X)$ we define

$$\langle f, j_N(g) \rangle := \mathbb{E}\langle f, g \rangle = \sum_{n=1}^N \langle x_n, x_n^* \rangle.$$

Clearly, the mapping

$$j_N : \varepsilon_N^{p'}(X^*) \rightarrow (\varepsilon_N^p(X))^*$$

is linear and contractive. In the same way each $g \in \varepsilon^{p'}(X^*)$ defines an element $j(g)$ of $(\varepsilon^p(X))^*$ and the resulting map

$$j : \varepsilon^{p'}(X^*) \rightarrow (\varepsilon^p(X))^*$$

is contractive.

We claim that j_N is injective. For if $j_N g = 0$ for some $g = \sum_{n=1}^N \varepsilon_n x_n^* \in \varepsilon_N^{p'}(X^*)$, then $\langle x, x_n^* \rangle = \langle \varepsilon_n x, j_N g \rangle = 0$ for all $1 \leq n \leq N$ and $x \in X$. It follows that $x_n^* = 0$ for all $1 \leq n \leq N$, and therefore $g = 0$. The proof that j is injective is similar.

Theorem 7.4.14. *Let X be a K -convex Banach space. Then for all $1 < p < \infty$ the following assertions hold:*

- (1) *for each $N \geq 1$, the embedding $j_N : \varepsilon_N^{p'}(X^*) \rightarrow (\varepsilon_N^p(X))^*$ induces an isomorphism of Banach spaces*

$$\varepsilon_N^{p'}(X^*) \simeq (\varepsilon_N^p(X))^*.$$

Moreover, $\|j_N\| \leq 1$ and $\|j_N^{-1}\| \leq K_{p,X}$.

- (2) *the embedding j induces an isomorphism of Banach spaces*

$$\varepsilon^{p'}(X^*) \simeq (\varepsilon^p(X))^*.$$

Moreover, $\|j\| \leq 1$ and $\|j^{-1}\| \leq K_{p,X}$.

Proof. (1): Fix $1 < p < \infty$ and $1 \leq n \leq N$. For each $g^* \in (\varepsilon_N^p(X))^*$, the linear mapping $x \mapsto \langle \varepsilon_n x, g^* \rangle$ is bounded on X and defines an element $x_n^* \in X^*$. Setting $g := \sum_{n=1}^N \varepsilon_n x_n^*$ we have $j_N(g) = g^*$. This shows that j_N is surjective. To obtain the required estimate let $\varepsilon > 0$ be arbitrary. By Proposition 1.3.1 we can find an $f \in L^p(\Omega; X)$ with $\|f\|_{L^p(\Omega; X)} \leq 1$ such that $|\langle f, g \rangle| \geq (1 - \varepsilon)\|g\|_{L^{p'}(\Omega; X^*)}$. It follows that

$$\begin{aligned} (1 - \varepsilon)\|g\|_{L^{p'}(\Omega; X^*)} &\leq |\langle f, g \rangle| = |\langle f, \pi_N g \rangle| = |\langle \pi_N f, g \rangle| \\ &\leq \|\pi_N f\|_{L^p(\Omega; X)} \|j_N(g)\|_{(\varepsilon_N^p(X))^*} \end{aligned}$$

$$\leq K_{p,X} \|j_N(g)\|_{(\varepsilon_N^p(X))^*}.$$

Since $\varepsilon > 0$ was arbitrary it follows that $\|j_N^{-1}\| \leq K_{p,X}$. The estimate $\|j_N\| \leq 1$ has already been noted above.

(2): This can be proved in the same way, except for some problems with convergence that have to be overcome. For $g^* \in (\varepsilon^p(X))^*$ and each $n \geq 1$, define the functionals $x_n^* \in X^*$ as in (1). We claim that the sum $\sum_{n \geq 1} \varepsilon_n x_n^*$ converges in $L^{p'}(\Omega; X^*)$ and thus defines an element $g \in \varepsilon^{p'}(X^*)$, and that we have $j(g) = g^*$. Once this claim has been proved the proof can be finished as in part (1).

By Proposition 7.4.12, X has non-trivial type, and therefore X^* has finite cotype by Proposition 7.1.13. In particular, X^* does not contain an isomorphic copy of c_0 . Hence, by the theorem of Hoffmann-Jørgensen and Kwapien (see Corollary 6.4.12), to prove the convergence of the series $\sum_{n \geq 1} \varepsilon_n x_n^*$ it suffices to show that its partial sums $g_N = \sum_{n=1}^N \varepsilon_n x_n^*$ satisfy $\sup_{N \geq 1} \|g_N\|_{L^{p'}(\Omega; X^*)} < \infty$.

Let $i_N : \varepsilon_N^p(X) \rightarrow \varepsilon^p(X)$ be the canonical inclusion mapping and define $g_N^* \in (\varepsilon_N^p(X))^*$ by $g_N^* := i_N^* g^*$. It is easily checked that $j_N g_N = g_N^*$, and now part (1) shows that

$$\begin{aligned} \|g_N\|_{L^{p'}(\Omega; X^*)} &\leq K_{p,X} \|j_N(g_N)\|_{(\varepsilon_N^p(X))^*} \\ &= K_{p,X} \|g_N^*\|_{(\varepsilon_N^p(X))^*} \\ &= K_{p,X} \leq K_{p,X} \|I_N^* g^*\|_{(\varepsilon_N^p(X))^*} \leq K_{p,X} \|g^*\|_{(\varepsilon^p(X))^*}. \end{aligned}$$

This proves that $\sup_{N \geq 1} \|g_N\|_{L^{p'}(\Omega; X^*)} < \infty$, establishing the claim. \square

7.4.d K -convexity and interpolation

We begin with an interpolation result for the K -convexity property itself. The K -convexity property interpolates:

Proposition 7.4.15. *Let (X_0, X_1) be an interpolation couple with both X_0 and X_1 K -convex. Let $\theta \in (0, 1)$ and let $p_0, p_1, p, q \in (1, \infty)$ satisfy $\frac{1}{p} = \frac{1-\theta}{p_0} + \frac{\theta}{p_1}$. The complex interpolation space $X_\theta = [X_0, X_1]_\theta$ and the real interpolation space $X_{\theta, p_0, p_1} = (X_0, X_1)_{\theta, p_0, p_1}$ are K -convex and*

$$K_{p, X_\theta} \leq K_{p_0, X_0}^{1-\theta} K_{p_1, X_1}^\theta \quad \text{and} \quad K_{p, X_{\theta, p_0, p_1}} \leq K_{p_0, X_0}^{1-\theta} K_{p_1, X_1}^\theta.$$

Recall that $X_{\theta, p_0, p_1} = (X_0, X_1)_{\theta, p}$ with equivalent norms (see Theorem C.3.14).

Proof. Since the projections π_N are bounded on $L^{p_i}(\Omega; X_i)$ with norms at most K_{p_i, X_i} , it follows from the properties of complex interpolation that each π_N is bounded on $L^p(\Omega; X_\theta)$ with norm at most $K_{p, X_0}^{1-\theta} K_{p, X_1}^\theta$. The result for the real interpolation space is proved in the same way. \square

In the following, K -convexity is used as a tool to guarantee a natural interpolation of the spaces $\varepsilon^p(X)$:

Theorem 7.4.16. *Let (X_0, X_1) be an interpolation couple of K -convex Banach spaces X_0 and X_1 . Let $\theta \in (0, 1)$ and assume that $p_0, p_1, p \in (1, \infty)$ satisfy $\frac{1}{p} = \frac{1-\theta}{p_0} + \frac{\theta}{p_1}$. Then:*

(1) *we have*

$$[\varepsilon^{p_0}(X_0), \varepsilon^{p_1}(X_1)]_\theta = \varepsilon^p(X_\theta)$$

with equivalence of norms

$$\|x\|_{\varepsilon^p(X_\theta)} \leq \|x\|_{[\varepsilon^{p_0}(X_0), \varepsilon^{p_1}(X_1)]_\theta} \leq K_{p_0, X_0}^{1-\theta} K_{p_1, X_1}^\theta \|x\|_{\varepsilon^p(X_\theta)}$$

for all sequences $x = (x_n)_{n \geq 1}$ in the complex interpolation space $X_\theta = [X_0, X_1]_\theta$.

(2) *we have*

$$(\varepsilon^{p_0}(X_0), \varepsilon^{p_1}(X_1))_{\theta, p_0, p_1} = \varepsilon^p(X_{\theta, p_0, p_1})$$

with equivalence of norms

$$\|x\|_{\varepsilon^p(X_{\theta, p_0, p_1})} \leq \|x\|_{(\varepsilon^{p_0}(X_0), \varepsilon^{p_1}(X_1))_{\theta, p_0, p_1}} \leq K_{p_0, X_0}^{1-\theta} K_{p_1, X_1}^\theta \|x\|_{\varepsilon^p(X_{\theta, p_0, p_1})}$$

for all sequences $x = (x_n)_{n \geq 1}$ in the real interpolation space $X_{\theta, p_0, p_1} = (X_0, X_1)_{\theta, p_0, p_1}$.

In both (1) and (2), the first inequality does not require any K -convexity assumptions.

Recall that $X_{\theta, p_0, p_1} = (X_0, X_1)_{\theta, p}$ with equivalent norms (see Appendix C.3.14).

Proof. It suffices to prove the corresponding results for the spaces $\varepsilon_N(X)$. Indeed, since $X_0, X_1, X_\theta, X_{\theta, p_0, p_1}$ have non-trivial type (see Propositions 7.1.3 and 7.4.12) they do not contain a copy of c_0 . Therefore, if we can prove the norm estimates uniformly in N , the corresponding results for the spaces $\varepsilon(X)$ follow from the theorem of Hoffmann-Jørgensen and Kwapien (Theorem 6.4.10).

In the case of $\varepsilon_N(X)$ the identities of the spaces under consideration follow from interpolation of product spaces and it suffices to prove the required estimates for the norms.

For any Banach space X define the isometry $R_N : \varepsilon_N^q(X) \rightarrow L^q(\Omega, X)$ by $R_N x = \sum_{n=1}^N \varepsilon_n x_n$, where $x = (x_n)_{n=1}^N$ is a sequence in X . Assuming that X is K -convex and $q \in (1, \infty)$, define $E_N : L^q(\Omega; X) \rightarrow \varepsilon_N^q(\Omega; X)$ by $E_N f = (\mathbb{E}(\varepsilon_n \pi_N f))_{n=1}^N$. Then $\|E_N f\|_{\varepsilon_N^q(\Omega; X)} = \|\pi_N f\|_{L^q(\Omega; X)} \leq K_{q, X}$ and hence E_N is bounded with norm $\leq K_{q, X}$.

Since $E_N R_N = I$, for all sequences $x = (x_n)_{n=1}^N$ in $X_\theta = [X_0, X_1]_\theta$, it follows that

$$\begin{aligned}
\|x\|_{[\varepsilon_N^{p_0}(X_0), \varepsilon_N^{p_1}(X_1)]_\theta} &= \|E_N R_N x\|_{[\varepsilon_N^{p_0}(X_0), \varepsilon_N^{p_1}(X_1)]_\theta} \\
&\leq K_{p_0, X_0}^{1-\theta} K_{p_1, X_1}^\theta \|R_N x\|_{[L^{p_0}(\Omega; X_0), L^{p_1}(\Omega; X_1)]_\theta} \\
&= K_{p_0, X_0}^{1-\theta} K_{p_1, X_1}^\theta \|R_N x\|_{L^p(\Omega; X_\theta)} \\
&= K_{p_0, X_0}^{1-\theta} K_{p_1, X_1}^\theta \|x\|_{\varepsilon_N^p(X_\theta)}.
\end{aligned}$$

Also,

$$\begin{aligned}
\|x\|_{\varepsilon_N^p(X_\theta)} &= \|R_N x\|_{L^p(\Omega; X_\theta)} \\
&= \|R_N x\|_{[L^{p_0}(\Omega; X_0), L^{p_1}(\Omega; X_1)]_\theta} \leq \|x\|_{[\varepsilon_N^{p_0}(X_0), \varepsilon_N^{p_1}(X_1)]_\theta};
\end{aligned}$$

this inequality does not require any K -convexity assumptions. This completes the proof for complex interpolation. The proof for real interpolation proceeds along the same lines. \square

In Proposition 7.1.3 we have seen that type is preserved under interpolation. As a consequence of the preceding theorem we obtain a similar result for cotype provided the spaces under consideration are K -convex:

Proposition 7.4.17. *Let (X_0, X_1) be an interpolation couple, with X_0 and X_1 K -convex, with finite cotype q_0 and q_1 , respectively. Let $\theta \in (0, 1)$ and assume that $\frac{1}{q} = \frac{1-\theta}{q_0} + \frac{\theta}{q_1}$. Then the complex interpolation space $X_\theta = [X_0, X_1]_\theta$ and the real interpolation space $X_{\theta, q_0, q_1} = (X_0, X_1)_{\theta, q_0, q_1}$ have cotype q , and we have*

$$\begin{aligned}
c_{q, X_\theta} &\leq K_{q_0, X_0}^{1-\theta} K_{q_1, X_1}^\theta c_{q_0, X_0}^{1-\theta} c_{q_1, X_1}^\theta, \\
c_{q, X_{\theta, q_0, q_1}} &\leq K_{q_0, X_0}^{1-\theta} K_{q_1, X_1}^\theta c_{q_0, X_0}^{1-\theta} c_{q_1, X_1}^\theta.
\end{aligned}$$

Proof. The operator $T : \varepsilon^{q_i}(X_i) \rightarrow \ell^{q_i}(X_i)$ given by $T(x_n)_{n \geq 1} = (x_n)_{n \geq 1}$ is bounded with norm $\leq c_{q_i, X_i}$. Therefore, by Theorem 7.4.14 and interpolation and, writing $x = (x_n)_{n \geq 1}$,

$$\begin{aligned}
\|Tx\|_{\ell^q(X_\theta)} &= \|Tx\|_{[\ell^{q_0}(X_0), \ell^{q_1}(X_1)]_\theta} \leq c_{q_0, X_0}^{1-\theta} c_{q_1, X_1}^\theta \|x\|_{[\varepsilon^{q_0}(X_0), \varepsilon^{q_1}(X_1)]_\theta} \\
&\leq c_{q_0, X_0}^{1-\theta} c_{q_1, X_1}^\theta K_{q_0, X_0}^{1-\theta} K_{q_1, X_1}^\theta \|x\|_{\varepsilon^q(X_\theta)}.
\end{aligned}$$

This proves that X_θ has cotype q , with the indicated bound for the cotype constant.

The result for real interpolation is proved in the same way. \square

7.4.e K -convexity with respect to general random variables

We have seen that the notions of type and cotype can be equivalently formulated in terms of appropriate sequences of independent identically distributed symmetric random variables. In particular, a Banach space has type p (cotype q) if and only if it has Gaussian type p (Gaussian cotype q). Here we will prove similar results for K -convexity.

Throughout this section we assume that ξ is a symmetric random variable with finite moments of all orders, normalised so that $\mathbb{E}|\xi|^2 = 1$, defined on some probability space (Ω, \mathbb{P}) . By $(\xi_n)_{n \geq 1}$ we denote a sequence of independent random variables, each of which is equidistributed with ξ .

Let $p \in (1, \infty)$. We define $K_{p,X}^{\xi,N}$ as the smallest constant such that

$$\left\| \sum_{n=1}^N \xi_n x_n \right\|_{L^p(\Omega; X)} \leq \sup \left\{ \left| \sum_{n=1}^N \langle x_n, x_n^* \rangle \right| : \left\| \sum_{n=1}^N \bar{\xi}_n x_n^* \right\|_{L^{p'}(\Omega; X^*)} \right\}$$

and π_N^ξ as the operator acting on $f \in L^p(\Omega; X)$ by

$$\pi_N^\xi f := \sum_{n=1}^N \xi_n \mathbb{E}(\bar{\xi}_n f).$$

Note that $\mathbb{E}(\bar{\xi}_n f)$ is well defined by Hölder's inequality, and the L^2 -normalisation of ξ ensures that each π_N^ξ is a projection in $L^p(\Omega; X)$. We say that X is K^ξ -convex if

$$K_{p,X}^\xi := \sup_{N \geq 1} K_{p,X}^{\xi,N} < \infty.$$

Mutatis mutandis, Proposition 7.4.5, Corollary 7.4.6 and Theorem 7.4.14 extend to this setting, showing in particular that

$$\|\pi_N^\xi\|_{\mathcal{L}(L^p(\Omega; X))} = K_{p,X}^{\xi,N} = K_{p',X^*}^{\bar{\xi},N} = K_{p',Y}^{\bar{\xi},N}$$

whenever $Y \subseteq X^*$ is a norming subspace for X ; note the appearance of the conjugations $\bar{\xi}$ in the last two constants, since in the considered generality ξ_n and $\bar{\xi}_n$ need not be equally distributed.

The main result of this subsection (Proposition 7.4.18) states that X is K^ξ -convex if and only if X is K -convex.

Proposition 7.4.18. *A Banach space X is K^ξ -convex if and only if X is K -convex. Moreover, for all $1 < p < \infty$ we have*

$$\|\xi\|_1^{-2} K_{p,X} \leq K_{p,X}^\xi \leq C_{p,X}^\xi K_{p,X},$$

where $C_{p,X}^\xi$ depends on X via the cotype properties of X and X^* .

Proof. If X is K^ξ -convex, then two applications of Proposition 6.1.15 give

$$\begin{aligned} \left\| \sum_{n=1}^N \varepsilon_n x_n \right\|_{L^p(\Omega; X)} &\leq \|\xi\|_1^{-1} \left\| \sum_{n=1}^N \xi_n x_n \right\|_{L^p(\Omega; X)} \\ &\leq \|\xi\|_1^{-1} K_{p,X}^\xi \sup \left\{ \left| \sum_{n=1}^N \langle x_n, x_n^* \rangle \right| : \left\| \sum_{n=1}^N \bar{\xi}_n x_n^* \right\|_{L^{p'}(\Omega; X^*)} \leq 1 \right\} \end{aligned}$$

$$\leq \|\xi\|_1^{-1} K_{p,X}^{\xi,N} \sup \left\{ \left| \sum_{n=1}^N \langle x_n, x_n^* \rangle \right| : \left\| \sum_{n=1}^N \bar{\varepsilon}_n x_n^* \right\|_{L^{p'}(\Omega; X^*)} \leq \|\xi\|_1^{-1} \right\},$$

and hence $K_{p,X}^N \leq \|\xi\|_1^{-2} K_{p,X}^{\xi,N}$.

Assume then that X is K -convex; proving that X is K^ξ -convex is the deeper direction of the theorem. By Proposition 7.4.5, X^* is also K convex. Hence by Proposition 7.4.12, both X and X^* have finite cotype, say q and r , respectively. Let $s := \max\{q, p\}$ and $t := \max\{r, p'\}$. Then X has cotype s , thus ξ -cotype s (Corollary 7.2.9), and hence by Proposition 7.2.8 we can estimate

$$\begin{aligned} \left\| \sum_{n=1}^N \xi_n x_n \right\|_{L^p(\Omega; X)} &\leq \left\| \sum_{n=1}^N \xi_n x_n \right\|_{L^s(\Omega; X)} \leq A_{s,X}^\xi \left\| \sum_{n=1}^N \varepsilon_n x_n \right\|_{L^s(\Omega; X)} \\ &\leq A_{s,X}^\xi K_{s,X}^N \left\{ \left| \sum_{n=1}^N \langle x_n, x_n^* \rangle \right| : \left\| \sum_{n=1}^N \varepsilon_n x_n^* \right\|_{L^{s'}(\Omega; X)} \leq 1 \right\}. \end{aligned}$$

Similarly, for any $x_1^*, \dots, x_N^* \in X^*$ as above, we note that X^* has cotype t , hence $\bar{\xi}$ -cotype t (Corollary 7.2.9), and applying again Proposition 7.2.8 we get

$$\begin{aligned} \left\| \sum_{n=1}^N \bar{\xi}_n x_n^* \right\|_{L^{p'}(\Omega; X^*)} &\leq \left\| \sum_{n=1}^N \bar{\xi}_n x_n^* \right\|_{L^t(\Omega; X^*)} \leq A_{t,X^*}^{\bar{\xi}} \left\| \sum_{n=1}^N \varepsilon_n x_n^* \right\|_{L^t(\Omega; X^*)} \\ &\leq A_{t,X^*}^{\bar{\xi}} \kappa_{t,s'} \left\| \sum_{n=1}^N \varepsilon_n x_n^* \right\|_{L^{s'}(\Omega; X)} \leq A_{t,X^*}^{\bar{\xi}} \kappa_{t,s'}. \end{aligned}$$

Substituting back, this shows that $K_{p,X}^{\xi,N} \leq A_{s,X}^\xi A_{t,X^*}^{\bar{\xi}} \kappa_{t,s'} K_{s,X}$. Since $K_{s,X}^N \leq \max\{\kappa_{s,p}, \kappa_{s',p'}\} K_{p,X}^N$ (Lemma 7.4.3), we obtain the claimed result with $C_{p,X}^\xi = A_{s,X}^\xi A_{t,X^*}^{\bar{\xi}} \kappa_{t,s'} \max\{\kappa_{s,p}, \kappa_{s',p'}\}$, where $s := \max\{q, p\}$ and $t := \max\{r, p'\}$, and $A_{s,X}^\xi$ and $A_{t,X^*}^{\bar{\xi}}$ are the constants from Proposition 7.2.8. \square

Remark 7.4.19. If $\xi \in L^\infty$, one can take $C_{p,X}^\xi = \|\xi\|_\infty^2$ in Proposition 7.4.18.

Corollary 7.4.20. *A Banach space is K -convex if and only if it is Gaussian K -convex, and*

$$\|\gamma\|_1^2 K_{p,X} \leq K_{p,X}^\gamma \leq C_{p,X}^\gamma K_{p,X}, \quad 1 < p < \infty,$$

where $C_{p,X}^\gamma$ depends on X via the cotype properties of X and X^* .

As an application of these notions we give a simple proof of the following result, which is a special case of much more general theorem of Pisier considered in the following subsection:

Proposition 7.4.21. *Every Banach space X with type 2 is K -convex, and*

$$K_{2,X}^\gamma \leq \tau_{2,X}^\gamma.$$

By Proposition 7.4.5, a similar result holds if X^* has type 2.

Proof. To prove this let $f = \sum_{m=1}^M \mathbf{1}_{\Omega_m} x_m$ be a simple random variable, with the sets Ω_m measurable, disjoint, and of positive probability. With $y_m := (\mathbb{P}(\Omega_m))^{1/2} x_m$ we have

$$\mathbb{E}\|f\|^2 = \sum_{m=1}^M \|y_m\|^2$$

and

$$\mathbb{E}|\langle f, x^* \rangle|^2 = \sum_{m=1}^M |\langle y_m, x^* \rangle|^2, \quad x^* \in X^*.$$

Let $z_n := \mathbb{E}(\bar{\gamma}_n f)$. Then, by the orthonormality of the Gaussian sequence $(\gamma_n)_{n \geq 1}$ in $L^2(\Omega)$,

$$\sum_{n=1}^N |\langle z_n, x^* \rangle|^2 = \sum_{n=1}^N |\mathbb{E}(\bar{\gamma}_n \langle f, x^* \rangle)|^2 \leq \mathbb{E}|\langle f, x^* \rangle|^2 = \sum_{m=1}^M |\langle y_m, x^* \rangle|^2$$

for all $x^* \in X^*$. Hence, by Theorem 6.1.25,

$$\begin{aligned} \mathbb{E}\|\pi_N^\gamma f\|^2 &= \mathbb{E}\left\| \sum_{n=1}^N \gamma_n z_n \right\|^2 \leq \mathbb{E}\left\| \sum_{m=1}^M \gamma_m y_m \right\|^2 \\ &\leq (\tau_{2,X}^\gamma)^2 \sum_{m=1}^M \|y_m\|^2 = (\tau_{2,X}^\gamma)^2 \mathbb{E}\|f\|^2. \end{aligned}$$

It follows that $\|\pi_N^\gamma\|_{\mathcal{L}(L^2(\Omega; X))} \leq \tau_{2,X}^\gamma$. This proves that X is Gaussian K -convex with constant $K_{2,X}^\gamma \leq \tau_{2,X}^\gamma$. \square

7.4.f Equivalence of K -convexity and non-trivial type

This subsection is devoted to Pisier's theorem which asserts that K -convexity is equivalent to non-trivial type. It is useful at this point to recall the notation of the Walsh functions $(w_\alpha)_{\alpha \subseteq \{1, \dots, N\}}$ introduced in Section 6.2.a. We observe that the real Rademacher projection π_N of any function

$$f = \sum_{\alpha \subseteq \{1, \dots, N\}} w_\alpha x_\alpha \in L^p(D^N; X) \tag{7.35}$$

is given by

$$\pi_N f = \sum_{n=1}^N w_{\{n\}} x_{\{n\}}.$$

and note that $K_{p,X}^{\mathbb{R}} = \sup_{N \geq 1} \|\pi_N\|_{\mathcal{L}(L^p(D^N; X))}$.

As a warm-up in this notation, we first give another proof of Proposition 7.4.21 with a slightly different constant.

Proposition 7.4.22. *Every Banach space X of type 2 is K -convex, and*

$$K_{2,X}^{\mathbb{R}} \leq \|g\|_1^{-1} \tau_{2,X}^g,$$

where g is a real standard Gaussian variable.

Proof. Let $(g_\alpha)_{\alpha \subseteq \{1, \dots, N\}}$ be a real Gaussian sequence and $(x_\alpha)_{\alpha \subseteq \{1, \dots, N\}}$ be a sequence in X . By Proposition 6.1.15, the contraction principle, and Theorem 7.1.20 (which can be applied since cotype 2 implies Gaussian cotype 2 by Proposition 7.1.18),

$$\begin{aligned} \left\| \pi_N \sum_{\alpha} w_{\alpha} x_{\alpha} \right\|_{L^2(\Omega; X)} &= \left\| \sum_{n=1}^N w_{\{n\}} x_{\{n\}} \right\|_{L^2(\Omega; X)} \\ &\leq \|g\|_1^{-1} \left\| \sum_{n=1}^N g_{\{n\}} x_{\{n\}} \right\|_{L^2(\Omega; X)} \leq \|g\|_1^{-1} \left\| \sum_{\alpha} g_{\alpha} x_{\alpha} \right\|_{L^2(\Omega; X)} \\ &\leq \|g\|_1^{-1} \tau_{2,X}^g \left\| \sum_{\alpha} w_{\alpha} x_{\alpha} \right\|_{L^2(\Omega; X)}. \end{aligned}$$

This implies that X is K -convex with $K_{2,X}^{\mathbb{R}} \leq \|g\|_1^{-1} \tau_{2,X}^g$. \square

Theorem 7.4.23 (Pisier). *A Banach space is K -convex if and only if it has non-trivial type.*

That K -convexity implies non-trivial type has already been shown in Proposition 7.4.12. The proof of the converse implication will occupy us for the remainder of this section. It will also produce an estimate for $K_{p,X}$ in terms of the type constant $\tau_{p,X}$.

Before turning to the proof we note a direct consequence:

Corollary 7.4.24. *A Banach space X has non-trivial type if and only if X^* has non-trivial type.*

Proof. By Proposition 7.4.5 X is K -convex if and only if X^* is K -convex. \square

We start with a general lemma. It is the only place in the deduction of K -convexity, where the non-trivial type assumption is used.

Lemma 7.4.25. *Let X be a Banach space with type $p \in (1, 2]$ and let $\frac{1}{p} + \frac{1}{p'} = 1$. Let $P_1, \dots, P_M \in \mathcal{L}(X)$ be commuting contractive projections on X . Then for any convex combination $S = \sum_{m=1}^M \lambda_m P_m$ one has*

$$\|Sx + x\| \geq \frac{1}{4} (2\tau_{p,X}^{\mathbb{R}})^{-p'} \|x\| \geq \frac{1}{4} (\pi\tau_{p,X})^{-p'} \|x\|.$$

Proof. It suffices to prove the left-hand inequality for real Banach spaces; for complex spaces X it follows by applying the real case to $X_{\mathbb{R}}$ noting that $\tau_{p,X}^{\mathbb{R}} = \tau_{p,X_{\mathbb{R}}}$. The right-hand side is trivial for real spaces X , and for complex spaces it follows from $\tau_{p,X}^{\mathbb{R}} \leq \frac{1}{2}\pi\tau_{p,X}$ (see (7.1)).

It thus remains to prove the left-hand inequality for real Banach spaces X . Let $x \in X$ with $\|x\| = 1$ be fixed and put $a := \|Sx + x\|$. As $\|S\| \leq 1$, for all $n \geq 0$ we have

$$\|S^{n+1}x + S^n x\| \leq a.$$

Hence, by the triangle inequality,

$$1 = \|x\| \leq \|S^n x\| + \sum_{i=0}^{n-1} \|S^{i+1}x + S^i x\| \leq \|S^n x\| + na. \quad (7.36)$$

Let $(r_n)_{n \geq 1}$ be a real Rademacher sequence on a probability space (Ω, \mathbb{P}) . On a distinct probability space (Ω', \mathbb{P}') let η_1, \dots, η_N be independent copies of a discrete random variable $\eta : \Omega' \rightarrow \mathcal{L}(X)$ satisfying $\mathbb{P}(\eta = P_m) = \lambda_m$ for all $1 \leq m \leq M$. Note that $\mathbb{E}'(\eta) = S$.

Fix $\omega \in \Omega$ and set

$$B := \{1 \leq n \leq N : r_n(\omega) = 1\}, \quad C := \{1 \leq n \leq N : r_n(\omega) = -1\}.$$

Put $k := |B|$ and $\ell := |C|$. Clearly, the sets B and C and the integers k and ℓ depend on N and the fixed $\omega \in \Omega$, but we shall omit this from the notation. Let $\eta^B = \prod_{n \in B} \eta_n$. From $\eta_n^2 = \eta_n$ we see that $\eta^B \eta_n = \eta^B$ for $n \in B$. Also, $\mathbb{E}' \eta^B = S^k$ and, for $n \in C$, $\mathbb{E}' \eta^B \eta_n = S^{k+1}$. By these observations and the fact that $\|\eta^B\| \leq 1$ pointwise, we obtain

$$\begin{aligned} \|kS^k x - \ell S^{k+1} x\| &= \left\| \mathbb{E}' \left(\sum_{n \in B} \eta^B x - \sum_{n \in C} \eta^B \eta_n x \right) \right\| \\ &\leq \mathbb{E}' \left\| \sum_{n \in B} \eta^B x - \sum_{n \in C} \eta^B \eta_n x \right\| \\ &= \mathbb{E}' \left\| \eta^B \left(\sum_{n=1}^N r_n(\omega) \eta_n x \right) \right\| \leq \mathbb{E}' \left\| \sum_{n=1}^N r_n(\omega) \eta_n x \right\|. \end{aligned}$$

On the other hand, since $kS^k x - \ell S^{k+1} x = NS^k x - \ell(S^k x + S^{k+1} x)$, it follows from (7.36) that

$$\begin{aligned} \|kS^k x - \ell S^{k+1} x\| &\geq \|NS^k x\| - \|\ell(S^k x + S^{k+1} x)\| \\ &\geq N(1 - ka) - \ell a = N - N^2 a + N\ell a - \ell a \geq N - N^2 a. \end{aligned}$$

We conclude that

$$N - N^2 a \leq \mathbb{E}' \left\| \sum_{n=1}^N r_n(\omega) \eta_n x \right\|.$$

Since $\omega \in \Omega$ was arbitrary, we can take expectations and apply Fubini's theorem and Hölder's inequality to obtain

$$\begin{aligned} \mathbb{E}\mathbb{E}'\left\|\sum_{n=1}^N r_n \eta_n x\right\| &\leq \mathbb{E}'\left(\mathbb{E}\left\|\sum_{n=1}^N r_n \eta_n x\right\|^p\right)^{1/p} \\ &\leq \tau_{p,X} \mathbb{E}'\left(\sum_{n=1}^N \|\eta_n x\|^p\right)^{1/p} = \tau_{p,X} N^{1/p} \end{aligned}$$

and therefore

$$N - N^2 a \leq \tau_{p,X} N^{1/p}.$$

Letting $N \rightarrow \infty$, we see that a must be non-zero.

If $a \geq \frac{1}{2}$, then $a = \|Sx + x\| \geq \frac{1}{2} \geq \frac{1}{4}(2\tau_{p,X}^{\mathbb{R}})^{-p'}$ (since $\tau_{p,X}^{\mathbb{R}} \geq 1$) and we are done. If $a < \frac{1}{2}$, then we choose $N \geq 1$ such that $\frac{1}{4} < Na \leq \frac{1}{2}$. It follows that $\frac{N}{2} \leq \tau_{p,X} N^{1/p}$, and therefore, $N \leq (2\tau_{p,X})^{p'}$. But then $a > \frac{1}{4N} \geq 4^{-1}(2\tau_{p,X})^{-p'}$. This concludes the proof. \square

Let us fix $p \in [1, \infty]$. On $L^p(D^M; X)$ we consider the multiplication operator A , defined by

$$Af = \sum_{\alpha} (\#\alpha) w_{\alpha} x_{\alpha},$$

where f is represented in the form (7.35) and $\#\alpha$ denotes the number of elements of the set α . In the same way we define, for $t \in \mathbb{R}$, the multiplication operators $T(t)$ on $L^p(D^M; X)$

$$T(t)f = \sum_{\alpha} e^{-(\#\alpha)t} w_{\alpha} x_{\alpha}.$$

Note that the function $t \mapsto T(t)$ is differentiable, with derivative

$$T'(t)f = -AT(t)f, \quad t \in \mathbb{R}.$$

It was shown in Lemma 6.2.1 (and its proof) that the operators $T(t)$ are contractions and can be represented as

$$T(t) = \prod_{m=1}^M (P_m + e^{-t}Q_m) = \prod_{m=1}^M ((1 - e^{-t})P_m + e^{-t}I), \quad (7.37)$$

where $P_m \in \mathcal{L}(L^p(D^M; X))$ is the averaging operator in the m th coordinate,

$$\begin{aligned} (P_m f)(d_1, \dots, d_M) &= \frac{1}{2}f(d_1, \dots, d_{m-1}, 1, d_{m+1}, \dots, d_M) \\ &\quad + \frac{1}{2}f(d_1, \dots, d_{m-1}, -1, d_{m+1}, \dots, d_M). \end{aligned}$$

and $Q_m = I - P_m$. Recall that each P_m is a contractive projection and that $P_m P_k = P_k P_m$ for all $1 \leq m, k \leq M$. Note that $P_m w_{\alpha} = 0$ if $m \in \alpha$ and $P_m w_{\alpha} = w_{\alpha}$ if $m \notin \alpha$.

Lemma 7.4.26. *Each operator $T(t)$ is a convex combination of commuting projections of the form $\prod_{m \in \alpha} P_m$ (where $P_\emptyset := I$).*

Proof. This follows by induction on N in the second product in (7.37). \square

In the next proposition we shall work over the complex scalars. In the case of a real Banach space X we can apply the results below to its complexification.

For all $\lambda \in \mathbb{C} \setminus \{0, 1, \dots, M\}$ the operator $(\lambda - A)$ is invertible on $L^p(D^M; X)$ and its inverse is given by

$$(\lambda - A)^{-1} \left(\sum_{\alpha} w_{\alpha} x_{\alpha} \right) = \sum_{\alpha} (\lambda - (\#\alpha))^{-1} w_{\alpha} x_{\alpha}.$$

For $\theta \in (0, \frac{\pi}{2})$ put

$$\Gamma_{\theta} := \{\lambda \in \mathbb{C} \setminus \{0\} : \arg(\lambda) = \pm\theta\}.$$

Proposition 7.4.27. *If X is a complex Banach space with type $p \in (1, 2]$, then:*

(1) *for all $s \in \mathbb{R} \setminus \{0\}$ we have*

$$\|(is - A)^{-1}\|_{\mathcal{L}(L^p(D^M; X))} \leq \frac{L}{|s|}, \quad (7.38)$$

where $L = 4\pi(2\tau_{p, X}^{\mathbb{R}})^{p'}$.

(2) *for $\theta = \arctan(2L)$ and $\lambda \in \mathbb{C} \setminus \overline{\Sigma_{\theta}}$ we have*

$$\|(\lambda - A)^{-1}\|_{\mathcal{L}(L^p(D^M; X))} \leq \frac{2L}{\sin(\theta)|\lambda|}. \quad (7.39)$$

Proof. (1): Fix $s \in \mathbb{R} \setminus \{0\}$ and set $t_0 = \pi/|s|$. By Proposition 7.1.4, $L^p(\Omega; X)$ has type p with constant $\tau_{p, L^p(\Omega; X)}^{\mathbb{R}} = \tau_{p, X}^{\mathbb{R}}$. It follows from Lemmas 7.4.25 and 7.4.26 that

$$\frac{1}{4}(2\tau_{p, X}^{\mathbb{R}})^{-p'} \|f\| \leq \|T(t_0)f + f\|.$$

On the other hand, since $T'(t)f = -AT(t)f$, it follows from the contractivity of $T(t)$ that

$$\begin{aligned} \|T(t_0)f + f\| &= \|e^{ist_0}T(t_0)f - f\| = \left\| \int_0^{t_0} e^{ist_0}T(t)(is - A)f \, dt \right\| \\ &\leq \int_0^{t_0} \|T(t)(is - A)f\| \, dt \leq t_0 \|(is - A)f\|. \end{aligned}$$

Combining these estimates, we obtain

$$\|(is - A)f\| \geq \frac{1}{4t_0}(2\tau_{p, X}^{\mathbb{R}})^{-p'} \|f\| = \frac{|s|}{L} \|f\|,$$

and (7.38) follows.

(2): We will deduce (2) from (1) using the following standard perturbation argument: If $\lambda_0, \lambda \in \mathbb{C}$ are such that $\lambda_0 - A$ is invertible and $|\lambda - \lambda_0| < \|(\lambda_0 - A)^{-1}\|^{-1}$, then $\lambda - A$ is invertible and

$$(\lambda - A)^{-1} = \sum_{n \geq 0} (\lambda_0 - \lambda)^n (\lambda_0 - A)^{-(n+1)}. \quad (7.40)$$

We apply this result as follows. Let $\theta = \arctan(2L)$. For $\lambda \in \Gamma_\theta$ write $\lambda = se^{\pm i\theta}$ and take $\lambda_0 := i\Im(\lambda)$. Then, by part (1),

$$\begin{aligned} |\lambda - \lambda_0| &= \frac{|\Im(\lambda)|}{\tan \theta} \leq \frac{L}{\tan \theta} \|(\lambda_0 - A)^{-1}\|_{\mathcal{L}(L^p(D^M; X))}^{-1} \\ &= \frac{1}{2} \|(\lambda_0 - A)^{-1}\|_{\mathcal{L}(L^p(D^M; X))}^{-1}, \end{aligned}$$

and (7.40) implies that

$$\begin{aligned} \|(\lambda - A)^{-1}\| &\leq \sum_{n \geq 0} |\lambda_0 - \lambda|^n \|(\lambda_0 - A)^{-1}\|^{n+1} \\ &\leq \|(\lambda_0 - A)^{-1}\| \sum_{n \geq 0} 2^{-n} \leq \frac{2L}{|\Im(\lambda)|} = \frac{2L}{\sin(\theta)|\lambda|}. \end{aligned}$$

Therefore, the analytic function $r(\lambda) := \lambda(\lambda - A)^{-1}$ is uniformly bounded on Γ_θ by $\frac{2L}{\sin(\theta)}$. By the three lines lemma of Proposition H.2.6 (applied to $\lambda \mapsto r(-\lambda)$) we find that $\|r(\lambda)\| \leq \frac{2L}{\sin(\theta)}$ for all $\lambda \in \mathbb{C}\overline{\Sigma_\theta}$ and this implies (7.39). \square

We are now ready to prove the remaining half of Theorem 7.4.23, namely, that non-trivial type implies K -convexity. The proof we are about to give uses the theory of analytic semigroups as presented in Appendix G.

End of the proof of Theorem 7.4.23. It remains to prove that a space of non-trivial type is K -convex.

Combining Proposition 7.4.27 with Theorem G.5.2, our operator $-A$ generates an analytic C_0 -semigroup $(T(z))_{z \in \Sigma_{\frac{1}{2}\pi - \theta}}$ on $L^p(D^m; X)$ which is uniformly bounded on this sector by a constant C_L depending only $L = 4\pi(2\tau_{p, X}^{\mathbb{R}})^{p'}$ and $\theta = \arctan(2L)$. More precisely, by (G.5)

$$C_L \leq \frac{2}{\cos(\theta)} \frac{2L}{\sin(\theta)} = \frac{8}{\sin(2\theta)}.$$

On the other hand, the formula

$$\tilde{T}(z)f := \sum_{\alpha \subseteq \{1, \dots, M\}} e^{-z(\#\alpha)} w_\alpha x_\alpha,$$

defines an analytic extension of $(T(t))_{t \geq 0}$ to the open right-half plane $\Sigma_{\frac{1}{2}\pi}$. By uniqueness of analytic extensions, $\tilde{T}(z) = T(z)$ on $\Sigma_{\frac{1}{2}\pi - \theta}$.

The punctured ball $B_r \setminus \{0\}$ with radius $r = e^{-2\pi L}$ is contained in the range of $\Sigma_{\frac{1}{2}\pi - \theta}$ under the mapping $z \mapsto e^{-z}$. Consequently, the analytic function $S : B_r \rightarrow \mathcal{L}(L^p(D^M; X))$ given by

$$T(z)f = \sum_{\alpha \subseteq \{1, \dots, M\}} z^{\#\alpha} w_\alpha x_\alpha$$

is uniformly bounded by C_L as well. By Cauchy's formula

$$\pi_M f = \sum_{\#\alpha=1} w_\alpha x_\alpha = \sum_{\alpha \subseteq \{1, \dots, M\}} \frac{1}{2\pi i} \int_{\partial B_r} \frac{z^{\#\alpha}}{z^2} w_\alpha x_\alpha dz = \frac{1}{2\pi i} \int_{\partial B_r} \frac{T(z)}{z^2} dz.$$

From this identity we infer that

$$\|\pi_M\| \leq r^{-1} C_L = e^{2\pi L} C_L \leq \frac{8e^{2\pi L}}{\sin(2\theta)} = \frac{8(L^2 + 1)e^{2\pi L}}{L} \leq 10Le^{2\pi},$$

where we used that $L \geq 4\pi(2\tau_{p,X}^{\mathbb{R}})^{p'} \geq 16\pi$ to simplify the expression. This shows that X is K -convex with constant $K_{p,X} \leq 10Le^{2\pi L}$. \square

From the above proof we actually see that the following explicit bound holds.

Theorem 7.4.28. *If X is a Banach space with type $p \in (1, 2]$, then X is K -convex and*

$$K_{p,X}^{\mathbb{R}} \leq 10Le^{2\pi L}, \quad L = 4\pi(2\tau_{p,X}^{\mathbb{R}})^{p'}.$$

For Hilbert spaces H and $p = 2$, we know $K_{2,H}^{\mathbb{R}} = 1$; the above estimate then takes the form

$$K_{2,H}^{\mathbb{R}} \leq 160\pi e^{32\pi^2} \approx 7 \cdot 10^{139},$$

which is roughly the square of the number of atoms in the universe (which is currently estimated to be within the range of 10^{78} to 10^{82}).

7.5 Contraction principles for double random sums

The inequalities for Rademacher sums and Gaussian sums in a Banach space X studied in the previous sections often fail for double and multiple random sums. Whether or not inequalities such as the contraction principle extend to such sums becomes a property that the space X may or may not have. For instance, a Banach space X is said to have *Pisier's contraction property* if the contraction principle holds for double (and then also for multiple) Rademacher (or equivalently, Gaussian) sums in X . A weaker form of this property, sufficient in many applications, is the *triangular contraction property*. As it turns

out, every space L^p with $1 \leq p < \infty$ enjoys Pisier's contraction property and every UMD Banach space enjoys the triangular contraction property. These facts will be of paramount importance in later chapters. For example, many multiplier theorems admit a vector-valued extension if and only if the Banach space has UMD and satisfies Pisier's contraction property.

7.5.a Pisier's contraction property

Let $(\varepsilon'_m)_{m \geq 1}$ and $(\varepsilon''_n)_{n \geq 1}$ be independent Rademacher sequences. By independence, there is no loss of generality in assuming that the sequences live on distinct probability spaces (Ω', \mathbb{P}') and (Ω'', \mathbb{P}'') , and we shall always assume this to make the arguments more transparent.

On the product space $(\Omega, \mathbb{P}) = (\Omega' \times \Omega'', \mathbb{P}' \times \mathbb{P}'')$, the sequence $(\varepsilon'_m \varepsilon''_n)_{m,n=1}^\infty$ consists of Rademacher variables, but as a doubly-indexed sequence it fails to be a Rademacher sequence. To see this let us put $\eta_{mn} := \varepsilon'_m \varepsilon''_n$. Knowing η_{11} , η_{12} , η_{21} , we can express η_{22} in terms of these random variables via the identity

$$\overline{\eta_{11} \eta_{12} \eta_{21}} = \overline{\varepsilon'_1 \varepsilon''_1 \varepsilon'_1 \varepsilon''_2 \varepsilon'_2 \varepsilon''_1} = \varepsilon'_2 \varepsilon''_2 = \eta_{22}.$$

Thus the random variables η_{mn} fail independence. Nevertheless, in many situations one would like to manipulate the η_{mn} as if they were a genuine Rademacher sequence. In particular one would like to have a contraction principle available.

Definition 7.5.1 (Pisier's contraction property). *A Banach space X is said to have Pisier's contraction property if there exists a constant $C \geq 0$ such that for all choices of finite scalar sequences $(a_{mn})_{m,n=1}^{M,N}$ and vectors $(x_{mn})_{m,n=1}^{M,N}$ in X ,*

$$\mathbb{E}' \mathbb{E}'' \left\| \sum_{m=1}^M \sum_{n=1}^N a_{mn} \varepsilon'_m \varepsilon''_n x_{mn} \right\|^2 \leq C^2 \|a\|_\infty \mathbb{E}' \mathbb{E}'' \left\| \sum_{m=1}^M \sum_{n=1}^N \varepsilon'_m \varepsilon''_n x_{mn} \right\|^2.$$

The least admissible constant in this definition is denoted by α_X . By a simple convexity argument, an equivalent definition is obtained (with the same best constant) if one only considers scalars a_{mn} of modulus one.

From a repeated application of the Kahane–Khinchine inequality,

$$\begin{aligned}
 & \left(\mathbb{E}' \mathbb{E}'' \left\| \sum_{m=1}^M \sum_{n=1}^N \varepsilon'_m \varepsilon''_n y_{mn} \right\|^p \right)^{1/p} \\
 & \leq \kappa_{p,q} \left(\mathbb{E}' \left(\mathbb{E}'' \left\| \sum_{n=1}^N \varepsilon''_n \sum_{m=1}^M \varepsilon'_m y_{mn} \right\|^q \right)^{p/q} \right)^{1/p} \\
 & = \kappa_{p,q} \left(\mathbb{E}' \left\| \sum_{m=1}^M \varepsilon'_m \sum_{n=1}^N \varepsilon''_n y_{mn} \right\|_{L^q(\Omega''; X)}^p \right)^{1/p} \quad (7.41) \\
 & \leq \kappa_{p,q}^2 \left(\mathbb{E}' \left\| \sum_{m=1}^M \sum_{n=1}^N \varepsilon'_m \varepsilon''_n y_{mn} \right\|_{L^q(\Omega''; X)}^q \right)^{1/q} \\
 & = \kappa_{p,q}^2 \left(\mathbb{E}' \mathbb{E}'' \left\| \sum_{m=1}^M \sum_{n=1}^N \varepsilon'_m \varepsilon''_n y_{mn} \right\|^q \right)^{1/q},
 \end{aligned}$$

we see that the moments of order 2 in Definition 7.5.1 may be replaced by moments of any order p . The resulting constants will be denoted by $\alpha_{p,X}$. Thus, $\alpha_X = \alpha_{2,X}$. For $1 \leq p, q < \infty$ the above estimate implies that

$$\frac{1}{\kappa_{p,q}^2 \kappa_{q,p}^2} \alpha_{p,X} \leq \alpha_{q,X} \leq \kappa_{p,q}^2 \kappa_{q,p}^2 \alpha_{p,X}.$$

Example 7.5.2. Every Hilbert space X has Pisier's contraction property, with constant $\alpha_X = 1$. This is clear by writing out the square norms as inner products and using the orthonormality of the sequence $(\varepsilon'_m \varepsilon''_n)_{m,n \geq 1}$ in L^2 :

$$\mathbb{E}(\varepsilon'_{m_1} \varepsilon''_{n_1} \cdot \overline{\varepsilon'_{m_2} \varepsilon''_{n_2}}) = \mathbb{E}(\varepsilon'_{m_1} \overline{\varepsilon'_{m_2}}) \cdot \mathbb{E}(\varepsilon''_{n_1} \overline{\varepsilon''_{n_2}}) = \delta_{m_1, m_2} \delta_{n_1, n_2} = \delta_{(m_1, n_1), (m_2, n_2)}.$$

Proposition 7.5.3. *Let (S, \mathcal{A}, μ) be a measure space and let $1 \leq p < \infty$. The space $L^p(S)$ has Pisier's contraction property. More generally, if X has Pisier's contraction property, then $L^p(S; X)$ has this property and*

$$\alpha_{p, L^p(S; X)} = \alpha_{p, X}.$$

Proof. For all $f_{mn} \in L^p(S; X)$, $m = 1, \dots, M$, $n = 1, \dots, N$, we have

$$\begin{aligned}
 & \mathbb{E}' \mathbb{E}'' \left\| \sum_{m=1}^M \sum_{n=1}^N a_{mn} \varepsilon'_m \varepsilon''_n f_{mn} \right\|_{L^p(S; X)}^p \\
 & = \int_S \mathbb{E}' \mathbb{E}'' \left\| \sum_{m=1}^M \sum_{n=1}^N a_{mn} \varepsilon'_m \varepsilon''_n f_{mn}(s) \right\|^p d\mu(s) \\
 & \leq \alpha_{p,X}^p \|a\|_\infty^p \int_S \mathbb{E}' \mathbb{E}'' \left\| \sum_{m=1}^M \sum_{n=1}^N \varepsilon'_m \varepsilon''_n f_{mn}(s) \right\|^p d\mu(s) \\
 & = \alpha_{p,X}^p \|a\|_\infty^p \mathbb{E}' \mathbb{E}'' \left\| \sum_{m=1}^M \sum_{n=1}^N \varepsilon'_m \varepsilon''_n f_{mn} \right\|_{L^p(S; X)}^p.
 \end{aligned}$$

This gives the bound $\alpha_{p,L^p(S;X)} \leq \alpha_{p,X}$. The opposite inequality follows from the fact that $L^p(S;X)$ contains X as a closed subspace (we are of course assuming here that $\dim L^p(S) \geq 1$ to avoid trivialities). \square

Pisier's contraction property is often applied through the following result, in which $(\varepsilon'_m)_{m \geq 1}$ and $(\varepsilon''_n)_{n \geq 1}$ are Rademacher sequences on probability spaces (Ω', \mathbb{P}') and (Ω'', \mathbb{P}'') respectively, and let $(\varepsilon_{mn})_{m,n \geq 1}$ are a doubly indexed Rademacher sequence on (Ω, \mathbb{P}) .

Proposition 7.5.4. *Let X be a Banach space and let $p \in [1, \infty)$. The following assertions are equivalent:*

- (1) X has Pisier's contraction property.
- (2) there exist constants $\alpha_{p,X}^+$ and $\alpha_{p,X}^-$ such that for all finite doubly indexed sequences $(x_{mn})_{m,n=1}^{M,N}$ in X we have

$$\begin{aligned} \frac{1}{\alpha_{p,X}^+} \left\| \sum_{m=1}^M \sum_{n=1}^N \varepsilon_{mn} x_{mn} \right\|_{L^p(\Omega; X)} \\ \leq \left\| \sum_{m=1}^M \sum_{n=1}^N \varepsilon'_m \varepsilon''_n x_{mn} \right\|_{L^p(\Omega' \times \Omega''; X)} \leq \alpha_{p,X}^- \left\| \sum_{m=1}^M \sum_{n=1}^N \varepsilon_{mn} x_{mn} \right\|_{L^p(\Omega; X)}. \end{aligned} \quad (7.42)$$

- (3) The mapping $\varepsilon_{mn} x \mapsto \varepsilon'_m \varepsilon''_n x$ induces an isomorphism of Banach spaces $\varepsilon_{MN}(X) \simeq \varepsilon_M(\varepsilon_N(X))$, such that every $\mathbf{x} = (x_{mn})_{m,n=1}^{M,N}$ satisfies

$$\frac{1}{\alpha_{p,X}^+} \|\mathbf{x}\|_{\varepsilon_{MN}^p(X)} \leq \|\mathbf{x}\|_{\varepsilon_M^p(\varepsilon_N^p(X))} \leq \alpha_{p,X}^- \|\mathbf{x}\|_{\varepsilon_{MN}^p(X)}.$$

The least admissible constants $\alpha_{p,X}^+$ and $\alpha_{p,X}^-$ in (7.42) satisfy

$$\max\{\alpha_{p,X}^+, \alpha_{p,X}^-\} \leq \alpha_{p,X} \leq \alpha_{p,X}^+ \alpha_{p,X}^-.$$

A Gaussian version of Proposition 7.5.4 will be proved in Corollary 7.5.19.

Proof. (1) \Rightarrow (2): By randomisation and Fubini's theorem,

$$\begin{aligned} \mathbb{E} \left\| \sum_{m=1}^M \sum_{n=1}^N \varepsilon_{mn} x_{mn} \right\|^p &= \mathbb{E}' \mathbb{E}'' \mathbb{E} \left\| \sum_{m=1}^M \sum_{n=1}^N \varepsilon_{mn} \varepsilon'_m \varepsilon''_n x_{mn} \right\|^p \\ &= \mathbb{E}' \mathbb{E}'' \left\| \sum_{m=1}^M \sum_{n=1}^N \varepsilon_{mn} \varepsilon'_m \varepsilon''_n x_{mn} \right\|^p \leq \alpha_{p,X}^p \mathbb{E}' \mathbb{E}'' \left\| \sum_{m=1}^M \sum_{n=1}^N \varepsilon'_m \varepsilon''_n x_{mn} \right\|^p. \end{aligned}$$

This gives the left-hand side inequality in (2). To prove the right-hand side inequality in (2) we fix scalars ε_{mn} of modulus one and use Pisier's contraction property once more to obtain

$$\begin{aligned} & \mathbb{E}'\mathbb{E}'' \left\| \sum_{m=1}^M \sum_{n=1}^N \varepsilon'_m \varepsilon''_n x_{mn} \right\|^p \\ &= \mathbb{E}'\mathbb{E}'' \left\| \sum_{m=1}^M \sum_{n=1}^N \varepsilon_{mn} \bar{\varepsilon}_{mn} \varepsilon'_m \varepsilon''_n x_{mn} \right\|^p \leq \alpha_{p,X}^p \mathbb{E}'\mathbb{E}'' \left\| \sum_{m=1}^M \sum_{n=1}^N \varepsilon_{mn} \varepsilon'_m \varepsilon''_n x_{mn} \right\|^p. \end{aligned}$$

Taking $\varepsilon_{mn} = \varepsilon_{mn}(\omega)$ and taking expectations,

$$\begin{aligned} & \mathbb{E}'\mathbb{E}'' \left\| \sum_{m=1}^M \sum_{n=1}^N \varepsilon'_m \varepsilon''_n x_{mn} \right\|^p \leq \alpha_{p,X}^p \mathbb{E}\mathbb{E}'\mathbb{E}'' \left\| \sum_{m=1}^M \sum_{n=1}^N \varepsilon_{mn} \varepsilon'_m \varepsilon''_n x_{mn} \right\|^p \\ &= \alpha_{p,X}^p \mathbb{E}'\mathbb{E}''\mathbb{E} \left\| \sum_{m=1}^M \sum_{n=1}^N \varepsilon_{mn} \varepsilon'_m \varepsilon''_n x_{mn} \right\|^p = \alpha_{p,X}^p \mathbb{E} \left\| \sum_{m=1}^M \sum_{n=1}^N \varepsilon_{mn} x_{mn} \right\|^p. \end{aligned}$$

(2) \Rightarrow (1): By Kahane's contraction principle applied to the left-hand side sum in (2) we see that X satisfies Pisier's contraction property with constant $\alpha_{p,X} \leq \alpha_{p,X}^+ \alpha_{p,X}^-$:

$$\begin{aligned} & \mathbb{E}'\mathbb{E}'' \left\| \sum_{m=1}^M \sum_{n=1}^N a_{mn} \varepsilon'_m \varepsilon''_n x_{mn} \right\|^p \\ & \leq (\alpha_{p,X}^-)^p \mathbb{E} \left\| \sum_{m=1}^M \sum_{n=1}^N a_{mn} \varepsilon_{mn} x_{mn} \right\|^p \\ & \leq (\alpha_{p,X}^-)^p \|a\|_\infty^p \mathbb{E} \left\| \sum_{m=1}^M \sum_{n=1}^N \varepsilon_{mn} x_{mn} \right\|^p \\ & \leq (\alpha_{p,X}^-)^p (\alpha_{p,X}^+)^p \|a\|_\infty^p \mathbb{E}'\mathbb{E}'' \left\| \sum_{m=1}^M \sum_{n=1}^N \varepsilon'_m \varepsilon''_n x_{mn} \right\|^p. \end{aligned}$$

(2) \Leftrightarrow (3): This is just a rewording of the definitions. \square

In order to generalise Proposition 7.5.4 to multiple sums we need the following notation. Let $(\varepsilon_k^{(j)})_{k \geq 1}$, $j = 1, \dots, d$, be independent Rademacher sequences. We are concerned with d -fold products of these random variables of the form

$$\varepsilon_{\mathbf{k}} := \prod_{j=1}^d \varepsilon_{k_j}^{(j)}, \quad \mathbf{k} = (k_1, \dots, k_d).$$

Also let $(\varepsilon_{\mathbf{k}})_{\mathbf{k} \in \mathbb{Z}_+^d}$ denote a Rademacher sequence indexed by \mathbb{Z}_+^d .

Proposition 7.5.5. *Let X be a Banach space and let $p \in [1, \infty)$. The following assertions are equivalent:*

(1) X has Pisier's contraction property;

(2) there exists a constant $C \geq 0$ such that for all scalar sequences $(a_{\mathbf{k}})_{\mathbf{k} \in \mathbb{Z}_+^d}$ in \mathbb{K} and all finitely non-zero $(x_{\mathbf{k}})_{\mathbf{k} \in \mathbb{Z}_+^d}$ in X one has

$$\left\| \sum_{\mathbf{k} \in \mathbb{Z}_+^d} a_{\mathbf{k}} \varepsilon_{\mathbf{k}} x_{\mathbf{k}} \right\|_{L^p(\Omega; X)} \leq C \|a\|_{\infty}^d \left\| \sum_{\mathbf{k} \in \mathbb{Z}_+^d} \varepsilon_{\mathbf{k}} x_{\mathbf{k}} \right\|_{L^p(\Omega; X)};$$

(3) there exist constants $C^+ \geq 0$ and $C^- \geq 0$ such that for all finitely non-zero $(x_{\mathbf{k}})_{\mathbf{k} \in \mathbb{Z}_+^d}$ in X one has

$$\frac{1}{C^+} \left\| \sum_{\mathbf{k} \in \mathbb{Z}_+^d} \varepsilon_{\mathbf{k}} x_{\mathbf{k}} \right\|_{L^p(\Omega; X)} \leq \left\| \sum_{\mathbf{k} \in \mathbb{Z}_+^d} \varepsilon_{\mathbf{k}} x_{\mathbf{k}} \right\|_{L^p(\Omega; X)} \leq C^- \left\| \sum_{\mathbf{k} \in \mathbb{Z}_+^d} \varepsilon_{\mathbf{k}} x_{\mathbf{k}} \right\|_{L^p(\Omega; X)}.$$

In this situation we may take $C \leq (\alpha_{p,X}^-)^{d-1} (\alpha_{p,X}^+)^{d-1}$ and $C^{\pm} \leq (\alpha_{p,X}^{\pm})^{d-1}$.

Proof. (1) \Rightarrow (2) and (1) \Rightarrow (3): The idea is to use an iteration argument to replace the Rademachers one by one by multi-indexed ones and then to use the Kahane contraction property. This gives the right-hand side estimate in (3). Reversing the argument gives the left-hand side estimate in (3), as well as (2). Let us write out the case $d = 3$. By independence we may assume that the $\varepsilon_l, \varepsilon'_m, \varepsilon''_n$ are defined on distinct probability spaces.

$$\begin{aligned} \mathbb{E} \mathbb{E}' \mathbb{E}'' \left\| \sum_{l,m,n=1}^N a_{lmn} \varepsilon_l \varepsilon'_m \varepsilon''_n x_{lmn} \right\|^p &= \mathbb{E} \mathbb{E}' \mathbb{E}'' \left\| \sum_{m,n=1}^N \varepsilon'_m \varepsilon''_n \left(\sum_{l=1}^N a_{lmn} \varepsilon_l x_{lmn} \right) \right\|^p \\ &\leq \alpha_{p,X}^- \mathbb{E} \mathbb{E}' \left\| \sum_{m,n=1}^N \varepsilon'_{mn} \left(\sum_{l=1}^N a_{lmn} \varepsilon_l x_{lmn} \right) \right\|^p \\ &\leq (\alpha_{p,X}^-)^2 \mathbb{E} \mathbb{E}' \left\| \sum_{l,m,n=1}^N \varepsilon_{lmn} a_{lmn} x_{lmn} \right\|^p. \end{aligned}$$

By the Kahane contraction principle,

$$\mathbb{E} \mathbb{E}' \left\| \sum_{l,m,n=1}^N \varepsilon_{lmn} a_{lmn} x_{lmn} \right\|^p \leq \|a\|_{\infty} \mathbb{E} \mathbb{E}' \left\| \sum_{l,m,n=1}^N \varepsilon_{lmn} x_{lmn} \right\|^p.$$

Finally, reversing the step in the previous computation,

$$\mathbb{E} \mathbb{E}' \left\| \sum_{l,m,n=1}^N \varepsilon_{lmn} a_{lmn} x_{lmn} \right\|^p \leq (\alpha_{p,X}^+)^2 \mathbb{E} \mathbb{E}' \mathbb{E}'' \left\| \sum_{l,m,n=1}^N a_{lmn} \varepsilon_l \varepsilon'_m \varepsilon''_n x_{lmn} \right\|^p.$$

(2) \Rightarrow (1) and (3) \Rightarrow (1): If the scalars a_{k_1, k_2} and vectors x_{k_1, k_2} are given, we apply (2) and (3) with $a_{\mathbf{k}} := a_{k_1, k_2}$ and $x_{\mathbf{k}} := x_{k_1, k_2}$ to arrive at the inequality in Definition 7.5.1, respectively condition (2) of Proposition 7.5.4. \square

We conclude this subsection with an important example of spaces failing Pisier's contraction property:

Proposition 7.5.6. *The Schatten class $\mathcal{C}^p(\ell^2)$ has Pisier's contraction property if and only if $p = 2$.*

Proof. The positive result for $p = 2$ is immediate from the fact that $\mathcal{C}^p(\ell^2)$ is a Hilbert space (see Appendix D). To prove the negative result for $p \neq 2$, it suffices to show that the relevant constant of the finite-dimensional spaces $\mathcal{C}^p(\ell_N^2)$ increase unboundedly as $N \rightarrow \infty$.

We represent operators on ℓ_n^2 as matrices $(a_{mn})_{m,n=1}^N$ with respect to the canonical basis $(e_n)_{n=1}^N$. Since $\epsilon_m a_{mn} = \sum_{k=1}^N \epsilon_m \delta_{mk} a_{kn}$ and $\epsilon'_n a_{mn} = \sum_{k=1}^N a_{mk} \delta_{kn} \epsilon'_n$, where the diagonal matrices $(d_{mk} = \epsilon_m \delta_{mk})_{m,k=1}^N$ and $(d'_{kn} = \epsilon'_n \delta_{kn})_{k,n=1}^N$ represent unitary operators for $|\epsilon_m| = |\epsilon'_n| = 1$, it follows from (D.5) that

$$\|(a_{mn})_{m,n=1}^N\|_{\mathcal{C}^p} = \|(\epsilon_m \epsilon'_n a_{mn})_{m,n=1}^N\|_{\mathcal{C}^p},$$

for any fixed $|\epsilon_m| = |\epsilon'_n| = 1$, and then, averaging over all such numbers, that

$$\|(a_{mn})_{m,n=1}^N\|_{\mathcal{C}^p} = \left\| \sum_{m,n=1}^N \epsilon_m \epsilon'_n a_{mn} E_{mn} \right\|_{L^2(\Omega; \mathcal{C}^p)},$$

where E_{mn} is the matrix with entry 1 at the position (m, n) , and all other entries equal to zero.

Now it is immediate from the definition of Pisier's contraction property that, if $|a_{mn}| = |b_{mn}|$, then

$$\frac{\|(a_{mn})_{m,n=1}^N\|_{\mathcal{C}^p}}{\alpha_{\mathcal{C}^p(\ell_N^2)}} \leq \|(b_{mn})_{m,n=1}^N\|_{\mathcal{C}^p} \leq \alpha_{\mathcal{C}^p(\ell_N^2)} \|(a_{mn})_{m,n=1}^N\|_{\mathcal{C}^p}. \quad (7.43)$$

With $N = 2^M$, let us consider the following two matrices on $\ell_N^2 = (\ell_2^2)^{\otimes M}$: Let $A := \left(\begin{smallmatrix} 1 & 1 \\ 1 & -1 \end{smallmatrix}\right)^{\otimes M}$, and B be simply the $N \times N$ matrix with all entries equal to one. Since $2^{-1/2} \left(\begin{smallmatrix} 1 & 1 \\ 1 & -1 \end{smallmatrix}\right)$ is a unitary matrix on ℓ_2^2 , the matrix A is $2^{M/2} = N^{1/2}$ times a unitary matrix on ℓ_N^2 , and hence it can be written as $A = N^{1/2} \sum_{n=1}^N (|q_n\rangle q_n)$ for some orthonormal basis $(q_n)_{n=1}^N$. Thus the approximation numbers of A are $a_n(A) = N^{1/2}$ for all $n = 1, \dots, N$, and hence

$$\|A\|_{\mathcal{C}^p} = \left(\sum_{n=1}^N a_n(A)^p \right)^{1/p} = N^{1/2+1/p}.$$

On the other hand, the matrix B has rank one, and can be written as $B = N(|e\rangle e)$, where $e = N^{-1/2} \sum_{n=1}^N e_n$. Thus $a_1(B) = N$ and $a_n(B) = 0$ for $n \geq 2$, so that $\|B\|_{\mathcal{C}^p} = N$. Since the two matrices have entries of size $|a_{mn}| = |b_{mn}| = 1$, we conclude from (7.43) that

$$\alpha_{\mathcal{C}^p(\ell_N^2)} \geq \max \left\{ \frac{N}{N^{1/p+1/2}}, \frac{N^{1/p+1/2}}{N} \right\} = N^{|1/2-1/p|}, \quad N = 2^M,$$

and this increases without limit as $N \rightarrow \infty$ unless $p = 2$. \square

7.5.b The triangular contraction property

In many application it suffices to have the following weaker version of Pisier's contraction property.

Definition 7.5.7. *A Banach space X has the triangular contraction property if there is a constant $\Delta_X \geq 0$ such that all finite sequences $(x_{mn})_{m,n=1}^M$ in X satisfy*

$$\left\| \sum_{m=1}^M \sum_{n=1}^m \varepsilon'_m \varepsilon''_n x_{mn} \right\|_{L^2(\Omega' \times \Omega''; X)} \leq \Delta_X \left\| \sum_{m=1}^M \sum_{n=1}^M \varepsilon'_m \varepsilon''_n x_{mn} \right\|_{L^2(\Omega' \times \Omega''; X)}.$$

We denote by Δ_X the least admissible constant in this inequality.

Interchanging the roles of the indices m and n in the above estimate, we could also have defined the triangular contraction property in terms of the lower triangular projections, and this leads to the same best constant Δ_X . Using this remark we see that the moments of order 2 in Definition 7.5.7 may be replaced by moments of any order p . The resulting constants will be denoted by $\Delta_{p,X}$. Thus, $\Delta_X = \Delta_{2,X}$. For $1 \leq p, q < \infty$, repetition of the estimate (7.41) shows that

$$\frac{1}{\kappa_{p,q}^2 \kappa_{q,p}^2} \Delta_{p,X} \leq \Delta_{q,X} \leq \kappa_{p,q}^2 \kappa_{q,p}^2 \Delta_{p,X}.$$

Trivially, every Banach space with Pisier's contraction property has the triangular contraction property and $\Delta_{p,X} \leq \alpha_{p,X}$. The converse does not hold: the Schatten class \mathcal{C}^p with $1 < p < \infty$ has the triangular contraction property but does not have Pisier's contraction property unless $p \neq 2$. We refer the reader to Example 7.6.18 in the Notes for a more details on this.

Below we will show that the triangular contraction property implies finite cotype. In particular this implies that c_0 does not have the triangular contraction property. On the other hand, we will see that every UMD space has the triangular contraction property, and that a Banach lattice has Pisier's contraction property if and only if it has finite cotype.

Proposition 7.5.8. *If X has the triangular contraction property, then so does $L^p(S; X)$ for all $p \in [1, \infty)$, and*

$$\Delta_{p, L^p(S; X)} = \Delta_{p, X}.$$

Proof. The proof is similar to the case of Pisier's contraction property in Proposition 7.5.3. \square

Theorem 7.5.9. *Every UMD space has the triangular contraction property, and $\Delta_{p,X} \leq \beta_{p,X}^+$ for all $p \in (1, \infty)$.*

For UMD Banach lattices this result can be improved: they even have the stronger Pisier’s contraction property; see Theorem 7.5.20 and the remark following it.

Proof. We need to show that

$$\mathbb{E}' \mathbb{E}'' \left\| \sum_{m=1}^M \sum_{n=1}^m \varepsilon'_m \varepsilon''_n x_{mn} \right\|^p \leq (\beta_{p,X}^+)^p \mathbb{E}' \mathbb{E}'' \left\| \sum_{m=1}^M \sum_{m=1}^M \varepsilon'_m \varepsilon''_n x_{mn} \right\|^p \quad (7.44)$$

for all vectors $x_{mn} \in X$ and $m, n = 1, \dots, M$. For $1 \leq n \leq M$ let $\mathcal{F}_n'' = \sigma(\varepsilon''_1, \varepsilon''_2, \dots, \varepsilon''_n)$ and $f_m = \sum_{n=1}^M \varepsilon''_n x_{mn}$. Then

$$\begin{aligned} \sum_{m=1}^M \sum_{n=1}^m \varepsilon'_m \varepsilon''_n x_{mn} &= \sum_{m=1}^M \varepsilon'_m \mathbb{E}(f_m | \mathcal{F}_n''), \\ \sum_{m=1}^M \sum_{n=1}^M \varepsilon'_m \varepsilon''_n x_{mn} &= \sum_{m=1}^M \varepsilon'_m f_m, \end{aligned}$$

so that (7.44) follows from the Stein inequality (Theorem 4.2.23). □

Next we prove that the triangular contraction property (and hence Pisier’s contraction property) implies finite cotype. Moreover, we will prove a Gaussian counterpart of Proposition 7.5.4. Since both of these properties are local, in view of Corollary 7.3.14, all we need to do is exhibit an example of a Banach space not having the triangular contraction property.

Proposition 7.5.10. *We have $\lim_{N \rightarrow \infty} \Delta_{\mathcal{L}(\ell_N^2)} = \infty$. As a consequence, the Banach space of all compact operators acting on ℓ^2 fails the triangular contraction property.*

For the proof we need two lemmas.

Lemma 7.5.11 (Discrete Hilbert transform). *For all $x \in \ell^2$,*

$$\sum_{m \in \mathbb{Z}} \left| \sum_{n \neq m} \frac{x_n}{m-n} \right|^2 \leq \pi^2 \|x\|^2.$$

Proof. By density it suffices to consider elements $x \in \ell^2$ with finite support. Let $f_x : [0, 1] \rightarrow \mathbb{C}$ be given by the finite sum $f_x(t) = \sum_{n \in \mathbb{Z}} e^{2\pi i n t} x_n$. Since $\int_0^1 (1-2t)e^{-2\pi i n t} dt$ equals $\frac{1}{\pi i n}$ for $n \neq 0$ and 0 for $n = 0$, for all $m \in \mathbb{Z}$ we have

$$y_m := \sum_{n \neq m} \frac{x_n}{m-n} = \sum_{n \neq 0} \frac{x_{m-n}}{n} = \sum_{n \neq 0} i\pi x_{m-n} \int_0^1 (1-2t)e^{-i2\pi n t} dt$$

$$\begin{aligned}
&= i\pi \int_0^1 e^{-2\pi i m t} (1-2t) \sum_{n \neq 0} x_{m-n} e^{2\pi i(m-n)t} dt \\
&= i\pi \int_0^1 e^{-2\pi i m t} (1-2t) f_x(t) dt.
\end{aligned}$$

Therefore, by Plancherel's identity,

$$\sum_{m \in \mathbb{Z}} |y_m|^2 = \pi^2 \int_0^1 |(1-2t)f_x(t)|^2 dt \leq \pi^2 \int_0^1 |f_x(t)|^2 dt = \pi^2 \sum_{m \in \mathbb{Z}} |x_m|^2.$$

□

Lemma 7.5.12. *Let N be a positive integer and let the lower triangle projection $T_N : \mathcal{L}(\ell_N^2) \rightarrow \mathcal{L}(\ell_N^2)$ be defined by*

$$(T_N A)_{mn} = \begin{cases} a_{mn}, & \text{if } m \geq n; \\ 0, & \text{otherwise,} \end{cases}$$

where we identified $A \in \mathcal{L}(\ell_N^2)$ with an $N \times N$ matrix (a_{mn}) . Then

$$\|T_N\| \geq \pi^{-1}(\log(N) - 1).$$

The same estimate holds for the norm of the upper triangle projection.

Proof. Let (a_{mn}) be the $N \times N$ Hilbert matrix with coefficients $a_{mn} = \frac{1}{m-n}$ if $m \neq n$ and $a_{mn} = 0$ if $m = n$. By Lemma 7.5.11, for all $x \in \ell_N^2$ we have

$$\|Ax\|^2 = \sum_{m=1}^N \left| \sum_{n \neq m} \frac{x_n}{m-n} \right|^2 \leq \pi^2 \|x\|^2.$$

On the other hand, since $e = (1, \dots, 1) \in \ell_N^2$ satisfies $\|e\| = \sqrt{N}$, we obtain

$$\begin{aligned}
\|T_N A\| &\geq N^{-1} |\langle (T_N A)e, e \rangle| = N^{-1} \sum_{m=1}^N \sum_{n=1}^{m-1} \frac{1}{m-n} \\
&\geq N^{-1} \sum_{m=1}^N \int_0^{m-1} \frac{1}{m-t} dt = N^{-1} \sum_{m=1}^N \log(m) \\
&\geq N^{-1} \int_0^N \log(t) dt = \log(N) - 1.
\end{aligned}$$

Therefore, $\log(N) - 1 \leq \|T_N A\| \leq \|T_N\| \|A\| \leq \pi \|T_N\|$. The final assertion is clear from the above proof. □

Proof of Proposition 7.5.10. Fix $N \geq 3$. By Lemma 7.5.12 it suffices to show that $\Delta_{\mathcal{L}(\ell_N^2)} \geq \|T_N\|$. Fix $x \in \mathcal{L}(\ell_N^2)$, let (u_{mn}) be the standard basis in

$\mathcal{L}(\ell_N^2)$ and write $x = \sum_{m,n=1}^N x_{mn}u_{mn}$. Let C and D be the random diagonal matrices defined by $c_{nn} = \varepsilon'_n$ and $d_{nn} = \varepsilon''_n$. By the ideal properties of the norm in $\mathcal{L}(\ell_N^2)$,

$$\|x\|_{\mathcal{L}(\ell_N^2)} = \|Cx D\|_{\mathcal{L}(\ell_N^2)} = \left\| \sum_{m=1}^N \sum_{n=1}^N \varepsilon'_m \varepsilon''_n x_{mn} u_{mn} \right\|_{\mathcal{L}(\ell_N^2)}.$$

On the other hand, taking square expectations,

$$\begin{aligned} \|x\|_{\mathcal{L}(\ell_N^2)}^2 &= \mathbb{E} \left\| \sum_{m=1}^N \sum_{n=1}^N \varepsilon'_m \varepsilon''_n x_{mn} u_{mn} \right\|_{\mathcal{L}(\ell_N^2)}^2 \\ &\geq \Delta_{\mathcal{L}(\ell_N^2)}^{-2} \mathbb{E} \left\| \sum_{m=1}^N \sum_{n=1}^m \varepsilon'_m \varepsilon''_n x_{mn} u_{mn} \right\|_{\mathcal{L}(\ell_N^2)}^2 \\ &= \Delta_{\mathcal{L}(\ell_N^2)}^{-2} \mathbb{E} \|CT_N x D\|_{\mathcal{L}(\ell_N^2)}^2 \\ &= \Delta_{\mathcal{L}(\ell_N^2)}^{-2} \|T_N x\|_{\mathcal{L}(\ell_N^2)}^2. \end{aligned}$$

Since $x \in \mathcal{L}(\ell_N^2)$ was arbitrary, this proves the result. □

Corollary 7.5.13. *If a Banach space X has the triangular contraction property, then X has finite cotype. In particular, if X has Pisier’s contraction property, then X has finite cotype.*

Proof. By Lemma 7.3.12, for every $N \geq 1$ we can find an integer $M = M(N)$ such that ℓ_M^∞ contains a 2-isomorphic copy of $\mathcal{L}(\ell_N^2)$. Therefore, $\Delta_{\ell_M^\infty} \geq \frac{1}{2} \Delta_{\mathcal{L}(\ell_N^2)}$. Since from Proposition 7.5.10 we know that $\lim_{N \rightarrow \infty} \Delta_{\mathcal{L}(\ell_N^2)} = \infty$, a Banach space containing the spaces ℓ_M^∞ uniformly cannot have the triangular contraction property. By the Maurey–Pisier Theorem 7.3.8, this proves the result. □

The converse of Corollary 7.5.13 does not hold. In the next proposition we show that the space of trace class operators $\mathcal{C}^1(\ell^2)$, which is known to have cotype 2, does not satisfy the triangular contraction property. The proof is similar to that in Proposition 7.5.10 but uses an additional trace duality argument.

Proposition 7.5.14. *We have $\lim_{N \rightarrow \infty} \Delta_{\mathcal{C}^1(\ell_N^2)} = \infty$. As a consequence, the space $\mathcal{C}^1(\ell^2)$ of trace class operators on ℓ^2 does not have the triangular contraction property.*

Proof. Fix $N \geq 3$. As before it suffices to estimate $\Delta_{\mathcal{C}^1(\ell_N^2)}$ from below. Let S_N be the lower triangle projection on the space $\mathcal{C}^1(\ell_N^2)$. As in the proof of Proposition 7.5.10, $\Delta_{\mathcal{C}^1(\ell_N^2)} \geq \|S_N\|$. By Theorem D.2.6, the trace duality pairing

$$\langle x, y \rangle = \text{tr}(xy), \quad x \in \mathcal{C}^1(\ell_N^2), \quad y \in \mathcal{L}(\ell_N^2).$$

sets up an isometric isomorphism $(\mathcal{C}^1(\ell_N^2))^* \simeq \mathcal{L}(\ell_N^2)$. Moreover, since $S_N^* = U_N$, the upper triangle projection on $\mathcal{L}(\ell_N^2)$, it follows that $\Delta_{\mathcal{C}^1(\ell_N^2)} \geq \|S_N\| = \|T_N\| \geq \pi^{-1}(\log(N) - 1)$. \square

7.5.c Duality and interpolation

We proceed with a duality result for the double random sum properties introduced in Section 7.5.

Proposition 7.5.15 (Duality of contraction properties). *Let X be a K -convex Banach space.*

- (1) X has Pisier's contraction property if and only if X^* has Pisier's contraction property.
- (2) X has the triangular contraction property if and only if X^* has the triangular contraction property.

Moreover, $\alpha_{X^*} \leq K_{2,X}^2 \alpha_X$ and $\Delta_{X^*} \leq K_{2,X}^2 \Delta_X$.

Proof. (1): Suppose first that X has Pisier's contraction property. Choose scalars a_{mn} such that $\sup_{m,n} |a_{mn}| \leq 1$. Let $(\varepsilon'_m)_{m=1}^M$ and $(\varepsilon''_n)_{n=1}^N$ be Rademacher sequences on probability spaces (Ω', \mathbb{P}') and (Ω'', \mathbb{P}'') , respectively. Let T be the bounded linear operator on $\varepsilon_N(\varepsilon_M(X))$ given by

$$T\left(\sum_{n=1}^N \sum_{m=1}^M \varepsilon''_n \varepsilon'_m x_{mn}\right) = \sum_{n=1}^N \sum_{m=1}^M a_{mn} \varepsilon''_n \varepsilon'_m x_{mn}.$$

Then $\|T\| \leq \alpha_X$. Let $\varepsilon > 0$ be arbitrary and fixed. Given $(x_{mn}^*)_{m,n=1}^{M,N}$ in X^* , put $g := \sum_{m=1}^M \sum_{n=1}^N \varepsilon'_m \varepsilon''_n x_{mn}^*$. By Proposition 1.3.1 we can find $f \in L^2(\Omega' \times \Omega''; X)$ of norm ≤ 1 such that

$$\|Tg\|_{L^2(\Omega' \times \Omega''; X^*)} \leq |\langle f, Tg \rangle| + \varepsilon.$$

Denote by π'_M and π''_N the Rademacher projections on Ω' and Ω'' respectively. As $Tg = \pi''_N \pi'_M Tg = \pi'_M \pi''_N Tg$ we obtain

$$\begin{aligned} |\langle f, Tg \rangle| &= |\langle T \pi''_N \pi'_M f, g \rangle| \\ &\leq \|T\| \|\pi''_N\| \|\pi'_M\| \|f\|_{L^2(\Omega' \times \Omega''; X)} \|g\|_{L^2(\Omega' \times \Omega''; X^*)} \\ &\leq \alpha_X K_{2,X}^2 \|g\|_{L^2(\Omega' \times \Omega''; X^*)}. \end{aligned}$$

Combining the estimates and letting $\varepsilon \downarrow 0$, we find $\|Tg\|_{L^2(\Omega' \times \Omega''; X^*)} \leq \alpha_X K_{2,X}^2 \|g\|_{L^2(\Omega' \times \Omega''; X^*)}$ and hence X^* has Pisier's contraction property.

For the converse assume that X^* has Pisier's contraction property. By Proposition 7.4.5 X^* is K -convex. Therefore, by the result just proved, X^{**} has Pisier's contraction property. Since X can be identified with a closed subspace of X^{**} , X has Pisier's contraction property.

(2): This follows from the proof of (1), taking $a_{mn} = 1$ if $m \leq n$ and $a_{mn} = 0$ otherwise. \square

By iterating the interpolation of $\varepsilon^p(X)$ -spaces in Theorem 7.4.16, we obtain:

Proposition 7.5.16. *Let (X_0, X_1) be an interpolation couple of K -convex Banach spaces X_0 and X_1 . Let $\theta \in (0, 1)$ and assume that $p_0, p_1, p \in (1, \infty)$ satisfy $\frac{1}{p} = \frac{1-\theta}{p_0} + \frac{\theta}{p_1}$. Then*

(1) *We have*

$$[\varepsilon^{p_0}(\varepsilon^{p_0}(X_0)), \varepsilon^{p_1}(\varepsilon^{p_1}(X_1))]_{\theta} = \varepsilon^p(\varepsilon^p(X_{\theta}))$$

with equivalence of norms

$$\begin{aligned} \|x\|_{\varepsilon^p(\varepsilon^p(X_{\theta}))} &\leq \|x\|_{[\varepsilon^{p_0}(\varepsilon^{p_0}(X_0)), \varepsilon^{p_1}(\varepsilon^{p_1}(X_1))]_{\theta}} \\ &\leq (K_{p_0, X_0}^{1-\theta} K_{p_1, X_1}^{\theta})^2 \|x\|_{\varepsilon^p(\varepsilon^p(X_{\theta}))} \end{aligned}$$

for all sequences $x = (x_n)_{n \geq 1}$ in the interpolation space $X_{\theta} = [X_0, X_1]_{\theta}$. The first inequality does not require any K -convexity assumptions.

(2) *Replacing each occurrence of the complex interpolation functor $[\cdot, \cdot]_{\theta}$ by the real interpolation functor $(\cdot, \cdot)_{\theta, p_0, p_1}$ in (1), the resulting statement is also true.*

Proof. As indicated, the proof is just an iteration of Theorem 7.4.16: For the identity of spaces, we have

$$[\varepsilon^{p_0}(\varepsilon^{p_0}(X_0)), \varepsilon^{p_1}(\varepsilon^{p_1}(X_1))]_{\theta} = \varepsilon^p([\varepsilon^{p_0}(X_0), \varepsilon^{p_1}(X_1)]_{\theta}) = \varepsilon^p(\varepsilon^p(X_{\theta})),$$

where both equalities are applications of Theorem 7.4.16. For the norm bounds, we have

$$\begin{aligned} \|x\|_{[\varepsilon^{p_0}(\varepsilon^{p_0}(X_0)), \varepsilon^{p_1}(\varepsilon^{p_1}(X_1))]_{\theta}} &\leq K_{p_0, \varepsilon^{p_0}(X_0)}^{1-\theta} K_{p_1, \varepsilon^{p_1}(X_1)}^{\theta} \|x\|_{[\varepsilon^{p_0}(X_0), \varepsilon^{p_1}(X_1)]_{\theta}} \\ &\leq K_{p_0, \varepsilon^{p_0}(X_0)}^{1-\theta} K_{p_1, \varepsilon^{p_1}(X_1)}^{\theta} K_{p_0, X_0}^{1-\theta} K_{p_1, X_1}^{\theta} \|x\|_{\varepsilon^p(\varepsilon^p(X_{\theta}))}, \end{aligned}$$

and moreover $K_{p_i, \varepsilon^{p_i}(X_i)} = K_{p_i, X_i}$ since $X_i \subseteq_1 \varepsilon^{p_i}(X_i) \subseteq_1 L^{p_i}(\Omega; X_i)$ and $K_{p_i, L^{p_i}(\Omega; X_i)} = K_{p_i, X_i}$ (Example 7.4.7). The remaining claims are similar and entirely routine. \square

As a consequence we have:

Proposition 7.5.17 (Interpolation of contraction properties). *Let (X_0, X_1) be an interpolation couple of K -convex Banach spaces X_0 and X_1 . Let $\theta \in (0, 1)$ and $p, p_0, p_1 \in (1, \infty)$ satisfy $\frac{1}{p} = \frac{1-\theta}{p_0} + \frac{\theta}{p_1}$.*

(1) *If X_0 and X_1 have Pisier's contraction property, then the complex interpolation spaces $X_{\theta} = [X_0, X_1]_{\theta}$ and the real interpolation spaces $X_{\theta, p_0, p_1} = (X_0, X_1)_{\theta, p_0, p_1}$ have Pisier's contraction property and*

$$\begin{aligned} \alpha_{p, X_{\theta}} &\leq (K_{p_0, X_0}^{1-\theta} K_{p_1, X_1}^{\theta})^2 \alpha_{p_0, X_0}^{1-\theta} \alpha_{p_1, X_1}^{\theta}, \\ \alpha_{p, X_{\theta, p_0, p_1}} &\leq (K_{p_0, X_0}^{1-\theta} K_{p_1, X_1}^{\theta})^2 \alpha_{p_0, X_0}^{1-\theta} \alpha_{p_1, X_1}^{\theta}. \end{aligned}$$

- (2) If X_0 and X_1 have the triangular contraction property, then the complex interpolation spaces $X_\theta = [X_0, X_1]_\theta$ and the real interpolation spaces $X_{\theta, p_0, p_1} = (X_0, X_1)_{\theta, p_0, p_1}$ have the triangular contraction property and

$$\begin{aligned}\Delta_{p, X_\theta} &\leq (K_{p_0, X_0}^{1-\theta} K_{p_1, X_1}^\theta)^2 \Delta_{p_0, X_0}^{1-\theta} \Delta_{p_1, X_1}^\theta, \\ \Delta_{p, X_{\theta, p_0, p_1}} &\leq (K_{p_0, X_0}^{1-\theta} K_{p_1, X_1}^\theta)^2 \Delta_{p_0, X_0}^{1-\theta} \Delta_{p_0, X_1}^\theta.\end{aligned}$$

Recall that $X_{\theta, p_0, p_1} = (X_0, X_1)_{\theta, p}$ with equivalent norms (see Appendix C.3.14). The reason the square of the K -convexity constant appears in the estimate is that the interpolation of ε -spaces of Theorem 7.4.16 has to be used twice due to the double random sums.

Proof. Both contraction properties are statements about uniform boundedness of operators $T : (x_{m,n})_{m,n \geq 1} \rightarrow (\alpha_{m,n} x_{m,n})_{m,n \geq 1}$ on $\varepsilon^P(\varepsilon^P(X))$, over different ranges of the coefficients $\alpha_{m,n}$. By Proposition 7.5.16, we have

$$\begin{aligned}\|T\|_{\mathcal{L}(\varepsilon^P(\varepsilon^P(X_\theta)))} &\leq (K_{p_0, X_0}^{1-\theta} K_{p_1, X_1}^\theta)^2 \|T\|_{\mathcal{L}([\varepsilon^{p_0}(\varepsilon^{p_0}(X_0)), \varepsilon^{p_1}(\varepsilon^{p_1}(X_1))]_\theta)} \\ &\leq (K_{p_0, X_0}^{1-\theta} K_{p_1, X_1}^\theta)^2 \|T\|_{\mathcal{L}(\varepsilon^{p_0}(\varepsilon^{p_0}(X_0)))}^{1-\theta} \|T\|_{\mathcal{L}(\varepsilon^{p_1}(\varepsilon^{p_1}(X_1)))}^\theta,\end{aligned}$$

and estimates for $\alpha_{p, X_\theta} = \sup_T \|T\|_{\mathcal{L}(\varepsilon^P(\varepsilon^P(X_\theta)))}$ and Δ_{p, X_θ} follow at once. The case of X_{θ, p_0, p_1} is entirely similar. \square

7.5.d Gaussian version of Pisier's contraction property

We next discuss a Gaussian version of Pisier's contraction property. In what follows we let $(\gamma_n)_{n \geq 1}$ and $(\gamma'_n)_{n \geq 1}$ be Gaussian sequences, defined on distinct probability spaces (Ω, \mathbb{P}) and (Ω', \mathbb{P}') respectively, and let $(\varepsilon'_n)_{n \geq 1}$ be a Rademacher sequence on (Ω', \mathbb{P}') . For any Banach space X , Proposition 6.1.15 and randomisation imply that

$$\begin{aligned}\left\| \sum_{n=1}^N \gamma_n x_n \right\|_{L^2(\Omega; X)} &= \left\| \sum_{n=1}^N \varepsilon'_n \gamma_n x_n \right\|_{L^2(\Omega \times \Omega'; X)} \\ &\leq \frac{1}{\mathbb{E}|\gamma|} \left\| \sum_{n=1}^N \gamma'_n \gamma_n x_n \right\|_{L^2(\Omega \times \Omega'; X)}.\end{aligned}$$

In the next proposition we show that the first and last random sum are equivalent if and only if X has finite cotype.

Proposition 7.5.18. *For a Banach space X the following assertions are equivalent:*

- (1) *there exists a constant $C > 0$ such that for all sequences x_1, \dots, x_N in X ,*

$$\left\| \sum_{n=1}^N \gamma_n \gamma'_n x_n \right\|_{L^2(\Omega \times \Omega'; X)} \leq C \left\| \sum_{n=1}^N \gamma_n x_n \right\|_{L^2(\Omega; X)}.$$

(2) X has finite cotype.

Proof. (2) \Rightarrow (1): Applying pointwise in $\omega \in \Omega$ the comparability of Gaussian and Rademacher sums in $L^2(\Omega'; X)$ established in Corollary 7.2.10 (also using the notation of the said corollary) and (de)randomisation, we have:

$$\begin{aligned} \left\| \sum_{n=1}^N \gamma_n \gamma'_n x_n \right\|_{L^2(\Omega \times \Omega'; X)} &\leq \kappa_{2,q}^* A_{q,X}^\gamma \left\| \sum_{n=1}^N \gamma_n \varepsilon'_n x_n \right\|_{L^2(\Omega \times \Omega'; X)} \\ &= \kappa_{2,q}^* A_{q,X}^\gamma \left\| \sum_{n=1}^N \gamma_n x_n \right\|_{L^2(\Omega; X)}. \end{aligned}$$

(1) \Rightarrow (2): By Lemma 7.3.12 and the Maurey–Pisier Theorem 7.3.8 it suffices to show that $\limsup_{N \rightarrow \infty} C_{\ell_N^\infty} = \infty$, where $C_{\ell_N^\infty}$ denotes the least constant for the right-hand side inequality in (1) for the space ℓ_N^∞ .

We claim that

$$\mathbb{E} \mathbb{E}' \left(\max_{1 \leq n \leq N} |\gamma'_n \gamma_n| \right) \geq \frac{1}{2e} \log N, \quad \mathbb{E} \left(\max_{1 \leq n \leq N} |\gamma_n|^2 \right) \leq 2 \log(2N). \quad (7.45)$$

The second estimate follows from Proposition E.2.21. For proving the first inequality we note that for all $t > 0$,

$$\begin{aligned} (\mathbb{P} \times \mathbb{P}')(|\gamma'_n \gamma_n| > t) &= \frac{2}{\pi} \int \int_{\{x>0, y>0, xy>t\}} e^{-\frac{1}{2}(x^2+y^2)} dx dy \\ &= \frac{2}{\pi} \int_0^{\frac{1}{2}\pi} \int_{\sqrt{2t/\sin 2\theta}}^\infty e^{-\frac{1}{2}r^2} r dr d\theta \\ &= \frac{2}{\pi} \int_0^{\frac{1}{2}\pi} e^{-t/\sin(2\theta)} d\theta \\ &\geq \frac{2}{\pi} \int_{\frac{1}{6}\pi}^{\frac{1}{2}\pi} e^{-2t} d\theta = \frac{2}{3} e^{-2t} > e^{-2t-1}. \end{aligned}$$

Thus,

$$\begin{aligned} \mathbb{E} \mathbb{E}' \left(\max_{1 \leq n \leq N} |\gamma'_n \gamma_n| \right) &= \int_0^\infty (\mathbb{P} \times \mathbb{P}') \{ \max_{1 \leq n \leq N} |\gamma'_n \gamma_n| > t \} dt \\ &\geq \int_0^\infty [1 - (1 - e^{-2t-1})^N] dt \\ &= \frac{1}{2} \int_0^{e^{-1}} \frac{1}{u} (1 - (1 - u)^N) du \\ &= \frac{1}{2} \int_0^{e^{-1}} \sum_{n=0}^{N-1} (1 - u)^n du \end{aligned}$$

$$= \frac{1}{2} \sum_{n=1}^N \frac{1}{n} \left(1 - (1 - e^{-1})^n\right) \geq \frac{\log(N+1)}{2e}.$$

This completes the proof of (7.45).

By (7.45) and the Cauchy–Schwarz inequality,

$$\left(\frac{1}{2e} \log N\right)^2 \leq \mathbb{E}' \mathbb{E} \left\| \sum_{n=1}^N \gamma'_n \gamma_n u_n \right\|_{\ell_N^\infty}^2 \leq C_{\ell_N^\infty}^2 \mathbb{E} \left\| \sum_{n=1}^N \gamma_n u_n \right\|_{\ell_N^\infty}^2 \leq C_{\ell_N^\infty}^2 2 \log(2N).$$

This implies that $\limsup_{N \rightarrow \infty} C_{\ell_N^\infty} = \infty$, and the result follows. \square

Corollary 7.5.19 (Pisier’s contraction property, Gaussian version).

For a Banach space X the following assertions are equivalent:

(1) for all finite doubly indexed sequences $(x_{mn})_{m,n=1}^{M,N}$ in X we have

$$\mathbb{E} \left\| \sum_{m=1}^M \sum_{n=1}^N \gamma_{mn} x_{mn} \right\|^2 \approx_X \mathbb{E}' \mathbb{E}'' \left\| \sum_{m=1}^M \sum_{n=1}^N \gamma'_m \gamma''_n x_{mn} \right\|^2. \quad (7.46)$$

(2) X has Pisier’s contraction property.

Proof. (2) \Rightarrow (1): By Corollary 7.5.13, (2) implies that X has finite cotype. By Proposition 6.1.15 and randomisation,

$$\mathbb{E}' \mathbb{E}'' \left\| \sum_{m=1}^M \sum_{n=1}^N \gamma'_m \gamma''_n x_{mn} \right\|^2 \approx_X \mathbb{E}' \mathbb{E}'' \left\| \sum_{m=1}^M \sum_{n=1}^N \varepsilon'_m \gamma''_n x_{mn} \right\|^2.$$

In the same way,

$$\mathbb{E}' \mathbb{E}'' \left\| \sum_{m=1}^M \sum_{n=1}^N \varepsilon'_m \gamma''_n x_{mn} \right\|^2 \approx_X \mathbb{E}' \mathbb{E}'' \left\| \sum_{m=1}^M \sum_{n=1}^N \varepsilon'_m \varepsilon''_n x_{mn} \right\|^2.$$

Putting this identities together, invoking Proposition 7.5.4, and using Proposition 6.1.15 once more, we obtain

$$\begin{aligned} \mathbb{E}' \mathbb{E}'' \left\| \sum_{m=1}^M \sum_{n=1}^N \gamma'_m \gamma''_n x_{mn} \right\|^2 &\approx_X \mathbb{E}' \mathbb{E}'' \left\| \sum_{m=1}^M \sum_{n=1}^N \varepsilon'_m \varepsilon''_n x_{mn} \right\|^2 \\ &\approx_X \mathbb{E} \left\| \sum_{m=1}^M \sum_{n=1}^N \varepsilon_{mn} x_{mn} \right\|^2 \approx_X \mathbb{E} \left\| \sum_{m=1}^M \sum_{n=1}^N \gamma_{mn} x_{mn} \right\|^2. \end{aligned}$$

(1) \Rightarrow (2): Taking $x_{mn} = x_n$ if $m = n$ and $x_{mn} = 0$ otherwise, it follows from Proposition 7.5.18 that X has finite cotype. Then, arguing in the same way,

$$\begin{aligned} \mathbb{E} \left\| \sum_{m=1}^M \sum_{n=1}^N \varepsilon_{mn} x_{mn} \right\|^2 &\approx_X \mathbb{E} \left\| \sum_{m=1}^M \sum_{n=1}^N \gamma_{mn} x_{mn} \right\|^2 \\ &\approx_X \mathbb{E}' \mathbb{E}'' \left\| \sum_{m=1}^M \sum_{n=1}^N \gamma'_m \gamma''_n x_{mn} \right\|^2 \approx_X \mathbb{E}' \mathbb{E}'' \left\| \sum_{m=1}^M \sum_{n=1}^N \varepsilon'_m \varepsilon''_n x_{mn} \right\|^2. \end{aligned}$$

By Proposition 7.5.4, this implies that X has Pisier's contraction property. \square

7.5.e Double random sums in Banach lattices

We conclude our discussion of double random sums by the following theorem, which shows that, in the special case of Banach lattices, Pisier's contraction property is but a reformulation of finite cotype.

Theorem 7.5.20 (Pisier). *A Banach lattice X has Pisier's contraction property if and only if it has finite cotype. Specifically, if X has cotype q , then*

$$\alpha_{2q, X} \leq 6(\kappa_{2,1}^{\mathbb{R}} \kappa_{p,2q})^2 c_{q, X}.$$

Since every UMD space has finite cotype by Proposition 7.3.15, as a consequence we note that every UMD lattice X has Pisier's contraction property.

Proof of Theorem 7.5.20. That Pisier's contraction property implies finite cotype was already observed in Corollary 7.5.13.

For the other direction, the key is to apply Proposition 7.2.15 to the simple function $f := \sum_{m=1}^M \sum_{n=1}^N r'_m r''_n \alpha_{mn} x_{mn}$. Using first the iterated Kahane–Khinchine inequality in (7.41), this gives

$$\begin{aligned} \left\| \sum_{m=1}^M \sum_{n=1}^N r'_m r''_n \alpha_{mn} x_{mn} \right\|_{L^p(\Omega; X)} &\leq (\kappa_{p,2q}^{\mathbb{R}})^2 \|f\|_{L^{2q}(\Omega; X)} \\ &\leq 3(\kappa_{p,2q}^{\mathbb{R}})^2 c_{q, X} \|f\|_{X(L^{2q}(\Omega))}. \end{aligned}$$

Writing out the definition, using the iterated Kahane–Khinchine inequality in (7.41) twice more and a trivial contractivity estimate of ℓ^2 sums in between, we have

$$\begin{aligned} \|f\|_{X(L^{2q}(\Omega))} &:= \left\| \left(\mathbb{E} \left| \sum_{m=1}^M \sum_{n=1}^N r'_m r''_n \alpha_{mn} x_{mn} \right|^{2q} \right)^{1/2q} \right\| \\ &\leq (\kappa_{2q,2}^{\mathbb{R}})^2 \left\| \left(\sum_{m=1}^M \sum_{n=1}^N |\alpha_{mn} x_{mn}|^2 \right)^{1/2} \right\| \leq (\kappa_{2q,2}^{\mathbb{R}})^2 \left\| \left(\sum_{m=1}^M \sum_{n=1}^N |x_{mn}|^2 \right)^{1/2} \right\| \\ &\leq (\kappa_{2q,2}^{\mathbb{R}} \kappa_{2,1}^{\mathbb{R}})^2 \left\| \mathbb{E} \left| \sum_{m=1}^M \sum_{n=1}^N r'_m r''_n x_{mn} \right| \right\| \leq (\kappa_{2q,2}^{\mathbb{R}} \kappa_{2,1}^{\mathbb{R}})^2 \mathbb{E} \left\| \sum_{m=1}^M \sum_{n=1}^N r'_m r''_n x_{mn} \right\| \end{aligned}$$

$$\leq (\kappa_{2q,2}^{\mathbb{R}} \kappa_{2,1}^{\mathbb{R}})^2 \left\| \sum_{m=1}^M \sum_{n=1}^N r'_m r''_n x_{mn} \right\|_{L^p(\Omega; X)}.$$

Finally, note that $3(\kappa_{2q,2}^{\mathbb{R}})^2 < 3 \cdot 2q = 6q$. \square

7.6 Notes

General references covering aspects of the geometry of Banach spaces related to this chapter include [Lindenstrauss and Tzafriri \[1979\]](#), [Pisier \[1989\]](#), [Ledoux and Talagrand \[1991\]](#), [Diestel, Jarchow, and Tonge \[1995\]](#), [Pietsch and Wenzel \[1998\]](#), [Li and Queffélec \[2004\]](#), [Albiac and Kalton \[2006\]](#), [Garling \[2007\]](#), and [Pisier \[2016\]](#).

Section 7.1

The story of the birth of the notions of type and cotype is told in the review paper by [Maurey \[2003\]](#). The origins are two-fold: on the one hand, type and cotype properties appeared in connection with summing operators, and on the other hand these notions allowed vector-valued extensions of some of the classical theorems of probability theory, such as the law of large numbers and the central limit theorem. Our presentation places the emphasis on the former, although in later chapters we will see plenty of applications of the ideas of this chapter to vector-valued harmonic and stochastic analysis.

The analogue of Proposition [7.1.3](#) for cotype does not hold in general (see [Garling and Montgomery-Smith \[1991\]](#)). Further examples of Banach space properties that do not interpolate (the Radon-Nikodým property being one of them) can be found in the same paper.

The order of the type and cotype constants of ℓ_N^1 and ℓ_N^∞ given in Proposition [7.1.7](#) is folklore. The type 2 constant τ_{2,ℓ_N^∞} has been studied in detail in [Dümbgen, van de Geer, Veraar, and Wellner \[2010\]](#). In particular, the following is shown:

$$c_N^2 := \mathbb{E} \max_{1 \leq n \leq N} |\gamma_n|^2 \leq \tau_{2,\ell_N^\infty}^2 \leq 2 \log(2N).$$

Moreover, in the real case $c_N^2/2 \log(2N) \rightarrow 1$ as $N \rightarrow \infty$.

The result that the Schatten classes \mathcal{C}^p , $p \in [1, \infty)$, have type $p \wedge 2$ and cotype $p \vee 2$ is due to [Tomczak-Jaegermann \[1974\]](#). In Proposition [7.1.11](#) we only covered the case $p \in (1, \infty)$; the case $p = 1$ requires a different argument and will not be needed here. The result has been extended to more general non-commutative L^p -spaces by [Fack \[1987\]](#).

Theorem [7.1.14](#) is due to [König and Tzafriri \[1981\]](#). An alternative approach due to [Hinrichs \[1996\]](#) based on the notion of Walsh type will be explained in Corollary [7.6.14](#).

It is an interesting observation of Pisier (see [James \[1978\]](#)) that in the definition of type 2 it suffices to consider vectors of norm one.

The results on ξ -type p and ξ -cotype q presented in Proposition 7.1.18 are folklore. A discussion on Proposition 7.1.19 and its consequences is given in the Notes of Section 7.2. Theorem 7.1.20(2) was proved by Dodds and Sukochev [1997].

The strong law of large numbers

The notion of type is closely connected to the strong law of large numbers in Banach spaces. Probability theory in Banach spaces is a subject in its own right, and all we can do here is to highlight some of the main results. The interested reader is referred to the monographs of Hoffmann-Jørgensen [1977], Ledoux and Talagrand [1991], Linde [1986] and Vakhania, Tarieladze, and Chobanyan [1987].

We recall a version of the strong law valid in general Banach spaces due to Mourier [1949] and contained in Theorem 3.3.10: If $(\xi_n)_{n \geq 1}$ is a sequence of independent, identically distributed random variables in $L^1(\Omega; X)$ with mean zero, then

$$\lim_{N \rightarrow \infty} \frac{1}{N} \sum_{n=1}^N \xi_n = 0 \quad \text{almost surely.} \quad (7.47)$$

It was the basic discovery of Beck [1962] that the assumption on identical distribution may be relaxed under a condition on the Banach space X :

Theorem 7.6.1 (Beck). *A Banach space X has non-trivial type if and only if the following property holds:*

For every sequence of independent mean zero random variables $(\xi_n)_{n \geq 1}$ that is bounded in $L^2(\Omega; X)$ we have (7.47).

Originally, this was stated in terms of so-called B -convexity (see Definition 7.6.7) instead of non-trivial type, but the two conditions are now known to be equivalent (see Proposition 7.6.8).

It is also possible to characterise any given type $p \in (1, 2]$ through a version of the strong law. This is due to Hoffmann-Jørgensen and Pisier [1976] and De Acosta [1981].

Proposition 7.6.2. *A Banach space X has type $p \in (1, 2]$ if and only if the following property holds:*

For every sequence of independent mean zero random variables $(\xi_n)_{n \geq 1}$ satisfying $\sum_{n \geq 1} n^{-p} \mathbb{E} \|\xi_n\|^p < \infty$, we have (7.47).

A thorough study of the strong law of large numbers, the central limit theorem, and the law of the iterated logarithm in Banach spaces is undertaken in Hoffmann-Jørgensen [1977] and Ledoux and Talagrand [1991].

Section 7.2

The notion of a summing operator has its roots in the work of Grothendieck [1953] who proved, in effect, that every operator from ℓ^1 to ℓ^2 is 1-summing; this is known as Grothendieck's inequality. The general definition of p -summing operators is due to Pietsch [1966/1967]. It was through the work of Lindenstrauss and Pełczyński [1971] that the fundamental importance of this inequality was realised and the connections with summing operators were established. Standard references for the modern theory of summing operators are the monographs Diestel, Jarchow, and Tonge [1995], Jameson [1987] and Tomczak-Jaegermann [1989]. They also provide extensive historical and bibliographical notes.

Proposition 7.2.3 implies that if X has cotype q , then the identity operator I_X is $(q, 1)$ -summing. In Talagrand [1992b], it was proved that the converse statement holds for $q > 2$. He also showed that the converse does not hold for $q = 2$ (see Talagrand [1992a]). We refer to the monograph Talagrand [2014, Chapter 16] for a survey of these results and several related open problems.

In Pisier's factorisation Theorem 7.2.4 one has $\pi_{q,1}(T) \leq C \leq q^{1/q} \pi_{q,1}(T)$. Montgomery-Smith [1990] proved that the factor $q^{1/q}$ is best possible. Kalton and Montgomery-Smith [1993] have extended Theorem 7.2.4 to quasi-Banach spaces and therefore many of the presented consequences can be proved in this setting as well (see Kalton [2005]). Defant and Sánchez Pérez [2009] proved a version of Theorem 7.2.4 for Banach function spaces instead of $L^{q,1}$ -spaces.

Theorem 7.2.6 is due to Hytönen and Veraar [2009] and can be viewed as an extension of Ledoux and Talagrand [1991, Proposition 9.14] and Pisier [1986a, Proposition 3.2(ii)], where (7.13) is proved in the case that the functions f_n of independent, symmetric, identically distributed random variables. A similar technique was used in Maurey and Pisier [1976]. Hytönen and Veraar [2009] also contains a dual version of Theorem 7.2.6 for spaces with type p , which generalises a corresponding results for independent identically distributed random variables in Ledoux and Talagrand [1991, Proposition 9.15]. In the case $q = 2$ in Theorem 7.2.6, a version of the estimate (7.14) (with different constant without blow-up) also holds at the end-point $r = q = 2$ and follows from Theorem 7.1.20. Corollary 7.1.24 for spaces of Gaussian cotype 2 is due to Pisier [1986b].

On the equivalence of ξ -cotype q and cotype q

Corollary 7.2.11, on the equivalence of Gaussian cotype q and cotype q , and Corollary 7.2.10, on the comparison of Rademacher and Gaussian sums, are due to Maurey and Pisier [1976]. They derived these results from the Maurey–Pisier Theorem 7.3.8 and a variant of Theorem 7.2.6. In Proposition 7.1.19 we gave a simple proof of the weaker statement that ξ -cotype q implies cotype r for every $r > q$ which is inspired by Talagrand [1992a]. In this paper a characterisation of operators $T : C(K) \rightarrow X$ of cotype q is given in terms of a factorisation through a certain Lorentz space depending on q .

The extension of Khintchine's inequality of Theorem 7.2.13 is due to Maurey [1974b]. For K -convex Banach lattices the difficult part of Theorem 7.2.13 can be proved by a duality argument which avoids the use of Pisier's factorisation Theorem 7.2.4:

Proposition 7.6.3. *Let X be a K -convex Banach lattice. Then*

$$\left\| \sum_{n=1}^N r_n x_n \right\|_{L^2(\Omega; X)} \leq K_{2, X} \kappa_{2, 1}^{\mathbb{R}} \left\| \left(\sum_{n=1}^N |x_n|^2 \right)^{1/2} \right\|.$$

Proof. The following version of the Cauchy–Schwarz inequality for the Krivine calculus discussed in Appendix F holds: for all $x_1^*, \dots, x_N^* \in X^*$,

$$\left| \sum_{n=1}^N \langle x_n, x_n^* \rangle \right| \leq \left\langle \left(\sum_{n=1}^N |x_n|^2 \right)^{1/2}, \left(\sum_{n=1}^N |x_n^*|^2 \right)^{1/2} \right\rangle,$$

where $\frac{1}{p} + \frac{1}{p'} = 1$. A proof can be found in Lindenstrauss and Tzafriri [1979, Proposition 1.d.2]. Hence by easy half of the Khintchine–Maurey inequality (Theorem 7.2.13), applied to X^* ,

$$\left| \sum_{n=1}^N \langle x_n, x_n^* \rangle \right| \leq \kappa_{2, 1}^{\mathbb{R}} \left\| \left(\sum_{n=1}^N |x_n|^2 \right)^{1/2} \right\| \left\| \sum_{n=1}^N r_n x_n^* \right\|_{L^2(\Omega; X^*)}.$$

Taking the supremum over all $x_n^*, \dots, x_N^* \in X^*$ subject to the condition $\left\| \sum_{n=1}^N r_n x_n^* \right\|_{L^2(\Omega; X^*)} \leq 1$ it follows from Corollary 7.4.6 that

$$\left\| \sum_{n=1}^N r_n x_n \right\|_{L^2(\Omega; X)} \leq K_{2, X} \kappa_{2, 1}^{\mathbb{R}} \left\| \left(\sum_{n=1}^N |x_n|^2 \right)^{1/2} \right\|.$$

□

Section 7.3

Our presentation of the factorisation theorems of Kwapien [1972] and Maurey [1974c] follows Albiac and Kalton [2006]. These theorems are frequently applied to show that certain results, valid in a Hilbert space context, cannot be extended to more general Banach spaces. One such application (already contained in Kwapien [1972]) is Theorem 7.3.5 which shows that, up to isomorphism, Hilbert spaces are the only Banach spaces with Fourier type 2. The original proof of Proposition 7.3.3 uses ultrafilter techniques to reduce the problem to the finite-dimensional case (see also Lindenstrauss and Pełczyński [1971, Theorem 7.3]).

The method used to prove Theorem 7.3.8 is a variation of Pisier [1974] and Hinrichs [1996]. There is a far-reaching generalisation of Theorem 7.3.8 due

to [Maurey and Pisier \[1976\]](#) and [Pisier \[1983\]](#). For $1 \leq p < 2$ it implies that if X does not contain the spaces ℓ_N^p uniformly, then X has type $p + \varepsilon$ for some $\varepsilon > 0$. We refer to [Maurey \[2003\]](#) and [Milman and Schechtman \[1986\]](#) for a detailed account on the general Maurey–Pisier theorem and its connections to local theory of geometry of Banach spaces.

Stable type

While [Theorem 7.3.8](#) is very handy for the qualitative verification of *some* non-trivial type or cotype, another variant is more useful for quantitative conclusions. This involves the following notion:

Definition 7.6.4. *A Banach space X has stable type $p \in (1, 2)$ with constant $\sigma_{p,X}$, if for any finite sequence $x_1, \dots, x_N \in X$ of arbitrary length N , we have*

$$\left\| \sum_{n=1}^N \theta_n^{(p)} x_n \right\|_{L^1(\Omega; X)} \leq \sigma_{p,X} \left(\sum_{n=1}^N \|x_n\|^p \right)^{1/p},$$

where $(\theta_n^{(p)})_{n \geq 1}$ is an independent sequence of p -stable random variables i.e., random variables with characteristic function $\mathbb{E} \exp(-it\theta_n^{(p)}) = \exp(-|t|^p)$.

For the existence and basic properties of p -stable random variables, see e.g. [Albiac and Kalton \[2006\]](#). Stable type implies type with the same index p (see [Pisier \[1986a\]](#)); in fact $\tau_{p,X} \lesssim (p-1)\sigma_{p,X}$ with a universal implied constant (see [Hytönen, Li, and Naor \[2016\]](#)). The promised variant of [Theorem 7.3.8](#) now reads as follows:

Theorem 7.6.5 (Pisier [1983]). *For every $\varepsilon \in (0, 1]$ and $p \in (1, 2)$, there exists $\delta_p(\varepsilon) > 0$ such that any Banach space X contains a $(1 + \varepsilon)$ -isomorphic copy of ℓ_N^p as long as*

$$N < \delta_p(\varepsilon) \sigma_{p,X}^{p'}.$$

An original application of this theorem was to reprove a result of [Johnson and Schechtman \[1982\]](#) on the existence of large ℓ_n^p subspaces of ℓ_N^1 ; namely, that $\ell_{\delta N}^p \subseteq_{1+\varepsilon} \ell_N^1$ for some $\delta = \delta(p, \varepsilon) > 0$. In another direction, this theorem says that if $\ell_N^p \not\subseteq_{1+\varepsilon} X$, then X must have stable (and hence usual) type p with a constant satisfying $\delta_p(\varepsilon) \sigma_{p,X}^{p'} \leq N$. In [Hytönen, Li, and Naor \[2016\]](#), it has been observed that one can take $\delta_p(1) \geq [c(p-1)]^{p'}$ for some universal $c \in (0, 1)$; whence $\delta_p(\varepsilon) \sigma_{p,X}^{p'} \geq (c\tau_{p,X})^{p'}$. This, in turn, was used to give the following quantitative elaboration of the folklore [Proposition 7.3.15](#) on the non-trivial type and cotype of UMD spaces:

Proposition 7.6.6. *There is a universal constant $a \in (1, \infty)$ such that every UMD space X has type $(a \cdot \beta_{2,X})'$ and cotype $a \cdot \beta_{2,X}$ with constants*

$$\tau_{(a \cdot \beta_{2,X})'} \leq a, \quad c_{a \cdot \beta_{2,X}} \leq a.$$

B-convexity

Another characterisation of non-trivial type is in terms of the following notion:

Definition 7.6.7 (B-convexity). *A Banach space is said to be B-convex if there exists an integer $N \geq 1$ and a $\delta > 0$ such that for all $x_1, \dots, x_N \in X$ there exist signs $\epsilon_1, \dots, \epsilon_N \in \{z \in \mathbb{K} : |z| = 1\}$ which satisfy*

$$\frac{1}{N} \left\| \sum_{n=1}^N \epsilon_n x_n \right\| \leq (1 - \delta) \max_{1 \leq n \leq N} \|x_n\|.$$

Proposition 7.6.8. *A Banach space is B-convex if and only if it has non-trivial type.*

Proof. Step 1: Suppose that X has no non-trivial type. We claim that X is not B-convex. Let $N \geq 1$ and $\delta > 0$ be arbitrary. By the Maurey–Pisier Theorem 7.3.8, X contains ℓ_N^1 $(1 + \delta)$ -uniformly. This means that we can find an isomorphic embedding $T : \ell_N^1 \rightarrow X$ such that $\|a\|_{\ell_N^1} \leq \|Ta\|_X \leq (1 + \delta)\|a\|_{\ell_N^1}$. Then, for all scalars $\epsilon_1, \dots, \epsilon_N$ of modulus one,

$$\frac{1}{N} \left\| \sum_{n=1}^N \epsilon_n T e_n \right\| \geq \frac{1}{N} \left\| \sum_{n=1}^N \epsilon_n e_n \right\|_{\ell_N^1} = 1 \geq (1 + \delta)^{-1} \max_{1 \leq n \leq N} \|T e_n\|,$$

where $(e_n)_{n=1}^N$ is the standard basis in ℓ_N^1 . This proves our claim.

Step 2: Suppose next that X has type $p \in (1, 2]$. Let $N \geq 1$ be any integer such that $\delta := 1 - N^{-1/p'} \tau_{p,X} > 0$. Then for $x_1, \dots, x_N \in X$,

$$\begin{aligned} \left\| \frac{1}{N} \sum_{n=1}^N \epsilon_n x_n \right\|_{L^p(\Omega; X)} &\leq N^{-1} \tau_{p,X} \left(\sum_{n=1}^N \|x_n\|^p \right)^{1/p} \\ &\leq N^{-1/p'} \tau_{p,X} \max_{1 \leq n \leq N} \|x_n\| = (1 - \delta) \max_{1 \leq n \leq N} \|x_n\|. \end{aligned}$$

It follows that there exists an $\omega \in \Omega$ with

$$\left\| \frac{1}{N} \sum_{n=1}^N \epsilon_n(\omega) x_n \right\| \leq (1 - \delta) \max_{1 \leq n \leq N} \|x_n\|,$$

This proves that X is B-convex. □

Metric versions of type and cotype

While the notion of type studied in this chapter requires the structure of an underlying normed space, close relatives of this notion can be defined in arbitrary metric spaces:

Definition 7.6.9. Let (X, d) be a metric space. For a function $f : D^N := \{-1, 1\}^N \rightarrow X$, we define the reflection $\tilde{f}(\epsilon) := f(-\epsilon)$ and the discrete gradient $\nabla f := (\partial_n f)_{n=1}^N : D^N \rightarrow [0, \infty)^N$, where

$$\partial_n f(\epsilon) := \frac{1}{2}d\left(f(\epsilon), f(\epsilon_1, \dots, \epsilon_{n-1}, -\epsilon_n, \epsilon_{n+1}, \dots, \epsilon_N)\right)$$

(1) The space X is said to have *Enflo-type* p if

$$\|\tfrac{1}{2}d(f, \tilde{f})\|_{L^p(D^N)} \leq \tau_{p,X}^E \|\nabla f\|_{L^p(D^N; \ell_p^p)}$$

(2) The space X is said to have *metric (or non-linear) type* p if

$$\|\tfrac{1}{2}d(f, \tilde{f})\|_{L^2(D^N)} \leq \tau_{p,X}^{nl} N^{1/p-1/2} \|\nabla f\|_{L^2(D^N; \ell_N^2)}$$

The notion of Enflo-type is implicit in [Enflo \[1978\]](#) and explicit in [Bourgain, Milman, and Wolfson \[1986\]](#), where also metric type was defined; the latter is called non-linear type by [Naor and Schechtman \[2002\]](#). Enflo-type p generalises the notion of p -roundness, which corresponds to the case $\tau_{p,X}^E = 1$, and which was earlier used by [Enflo \[1969\]](#) to show that $L^{p_1}(0, 1)$ and $L^{p_2}(0, 1)$ are not uniformly homeomorphic for $1 \leq p_1 < p_2 \leq 2$. The main result of [Bourgain, Milman, and Wolfson \[1986\]](#) is a metric analogue of [Theorem 7.3.8](#): A metric space has non-linear type $p > 1$ if and only if it does not contain uniform bi-Lipschitz images of the discrete cubes $\{-1, 1\}^N$ with the Hamming distance.

If X is a Banach space and $f(\varepsilon) = \sum_{n=1}^N \varepsilon_n x_n$ with $x_1, \dots, x_N \in X$, then $\tfrac{1}{2}d(f, \tilde{f}) = \|f\|$ and $\partial_n f = \|x_n\|$. From this it is immediate that $\tau_{p,X} \leq \tau_{p,X}^E$; indeed, the usual type is simply the specialisation of Enflo-type to the Rademacher sums in place of general functions on D^N . Similarly, $\tau_{2,X}(N) \leq \tau_{p,X}^{nl} N^{1/p-1/2}$, where $\tau_{2,X}(N)$ appears in [Definition 7.3.16](#). Deeper implications between the different notions are summarised in the following:

Theorem 7.6.10 (Bourgain, Milman and Wolfson; Pisier; Naor and Schechtman). Let X be a Banach space, and let $p \in (1, 2]$ and $p_1 \in [1, p)$.

- (1) If X has type p , then it has *Enflo-type* p_1 .
- (2) If X has *Enflo-type* p , then it has *metric type* p_1 .
- (3) If X has *metric type* p , then it has type p_1 .
- (4) If X is a *UMD space of type* p , then it has *Enflo-type* p .
- (5) If X is a *UMD space of Enflo-type* p , then it has *metric type* p .

Here (1) is due to [Pisier \[1986a\]](#), while (2) was pointed out in the same paper as an immediate consequence of the results of [Bourgain, Milman, and Wolfson \[1986\]](#), who first proved the resulting implication from type $p \in (1, 2]$ to metric type $p_1 \in [1, p)$, as well as its partial converse (3). Another proof of these results is given by [Pisier \[1986a\]](#).

The improvements in UMD spaces, (4) and (5), are due to [Naor and Schechtman \[2002\]](#). Their key tool for these results is a version of Pisier's

discrete Poincaré inequality (4.59) discussed in the Notes of Chapter 4. In the absence of the UMD property, the implications in (4) and (5) present interesting open problems.

It has been a longstanding open problem how to define cotype in metric spaces in such a way that for Banach spaces it coincides with the usual notion of cotype. After more than 20 years this was solved in Mendel and Naor [2008]. Stating their definition would take us somewhat afield, but their main result is easy to state:

Theorem 7.6.11 (Mendel–Naor). *Let X be a Banach space and $q \in [2, \infty)$. Then X has metric cotype q if and only if X has cotype q .*

Parts of the aforementioned developments on metric type and cotype were motivated by Ribe [1976], who proved that uniformly homeomorphic Banach spaces have the same finite dimensional subspaces. An excellent introduction to type and cotype in metric spaces and their connections to non-linear geometry of Banach spaces is given in Naor [2012]. This paper also presents several applications, notably in probability theory and computer science, and a number of open problems is formulated.

Section 7.4

The notion of K -convexity was introduced by Maurey and Pisier [1976] in order to obtain duality results for cotype analogous to those for type. Theorem 7.4.23 is due to Pisier [1982]. Our proof essentially follows the presentation of Maurey [2003] except that we use the theory of analytic semigroups from Section G.5 to shorten the presentation. It would be interesting to have a proof which provides a better constant (cf. the discussion on Walsh type and K -convexity below). In Pisier [1982] is explained that for a large class of analytic semigroups on $L^p(G)$ the tensor extension to $L^p(G; X)$ is analytic as well in case X is K -convex or satisfies other geometric conditions. A new class of examples was recently found by Arhancet [2015] assuming X satisfies a non-commutative version of K -convexity.

Pisier has shown (see Maurey [2003]) that if a finite-dimensional Banach space X is isomorphic to a Hilbert space H of the same dimension, then $K_{2,X} \leq 4 \log(d_{X,H})$, where

$$d_{X,H} = \inf \{ \|T\| \|T^{-1}\| : T : X \rightarrow Y \text{ isomorphism} \}$$

is the so-called *Banach–Mazur distance* between X and H .

The idea of the proof of Lemma 7.4.3 goes back to Tomczak-Jaegermann [1989], where the equivalence of Gaussian and Rademacher K -convexity is proved with a similar method. Theorem 7.4.16 can be found in Kaip and Saal [2012].

Walsh type and K -convexity

An alternative approach to Pisier's characterisation of K -convexity (see Theorem 7.4.23) was discovered by Hinrichs [1996, 1999] (see also Pietsch and Wenzel [1998]). A key ingredient is the notion of Walsh type 2. Following the notation introduced in the main text, a Banach space X is said to have *Walsh type 2* if there exists a constant $\omega \geq 0$ such that for all $(x_\alpha)_{\alpha \subseteq \{1, \dots, n\}}$ in X we have

$$\left\| \sum_{\alpha} w_{\alpha} x_{\alpha} \right\|_{L^2(D^n; X)} \leq \omega \left(\sum_{\alpha} \|x_{\alpha}\|^2 \right)^{1/2}.$$

The least admissible constant is denoted by $\omega_X(2^n)$. It increases with n and it is easy to check that it is sub-multiplicative in the sense that

$$\omega_X(2^{m+n}) \leq \omega_X(2^m) \omega_X(2^n). \quad (7.48)$$

The constants $\omega_X(2^n)$ are the Walsh analogues of the corresponding constants $\tau_X(N)$ (with $N = 2^n$) from Definition 7.3.16. If H is a Hilbert space, then $\omega_H(2^n) = 1$ by orthogonality. The following result was proved in Hinrichs [1999] in the more general setting of K -convex operators.

Theorem 7.6.12 (Hinrichs). *For all $\delta \in [0, \frac{1}{2})$ there exists a constant $C_{\delta} \geq 0$ such that for all $n \geq 1$ the Rademacher projection π_n on $L^2(D^n; X)$ is bounded of norm*

$$\|\pi_n\| \leq C_{\delta} \max_{1 \leq m \leq n} 2^{-m\delta} \omega_X(2^m).$$

In particular, if for some $\delta \in [0, \frac{1}{2})$ one has $\sup_{m \geq 1} 2^{-m\delta} \omega_X(2^m) < \infty$, then X is K -convex.

By checking the estimates in Hinrichs paper one can see that the constant C_{δ} is also a very large number. However, it is better than the one in the proof of Theorem 7.4.28. A technical but key difference in the proofs is that using the Walsh type 2 constants Hinrichs was able to give a lower estimate for $\|\sigma x + T(t)x\|$ for any $\sigma \in (\frac{2}{3}, 1]$, and in Proposition 7.4.27 we only give an estimate for $\sigma = 1$.

To see how to deduce K -convexity for spaces with non-trivial type from Theorem 7.6.12, we need some results on the constants $\omega_X(2^n)$ which are of independent interest. The following key estimate is due to Hinrichs [1996], where it is formulated for an arbitrary finite orthonormal system.

Proposition 7.6.13. *For all $n \geq 1$ one has $2^{n/2} \omega_X(2^n) \leq n^{1/2} \tau_X(n)$.*

Proof. Let $r_j = w_{\{j\}}$ for $j \in \{1, \dots, n\}$ and define the sets W and W_{α} by

$$W_{\alpha} = \{w_{\alpha} r_j : 1 \leq j \leq n\}, \quad \text{for } \alpha \subseteq \{1, \dots, n\}.$$

Then $\bigcup_{\alpha} W_{\alpha} = W$. Moreover, for every $\beta \subseteq \{1, \dots, n\}$ one has

$$\#\{\alpha \in \{1, \dots, n\} : w_\beta \in W_\alpha\} = n.$$

Therefore, for any choice $(x_w)_{w \in W}$ one has

$$\begin{aligned} \left\| \sum_{\alpha} w_{\alpha} x_{\alpha} \right\|_2 &= \left\| n^{-1} \sum_{\alpha \subseteq \{1, \dots, n\}} \sum_{w \in W_{\alpha}} w x_w \right\|_2 \\ &\leq n^{-1} \sum_{\alpha \subseteq \{1, \dots, n\}} \left\| \sum_{w \in W_{\alpha}} w x_w \right\|_2 \\ &\leq n^{-1} \sum_{\alpha \subseteq \{1, \dots, n\}} \tau_X(n) \left(\sum_{w \in W_{\alpha}} \|x_w\|^2 \right)^{1/2} \\ &\leq \tau_X(n) 2^{n/2} n^{-1} \left(\sum_{\alpha \subseteq \{1, \dots, n\}} \sum_{w \in W_{\alpha}} \|x_w\|^2 \right)^{1/2} \\ &= \tau_X(n) (n^{-1} 2^n)^{1/2} \left(\sum_{\alpha} \|x_{\alpha}\|^2 \right)^{1/2}. \end{aligned}$$

□

If X has type $p \in (1, 2]$, then by Proposition 7.6.13 and Lemma 7.3.17,

$$\omega_X(2^n) \leq 2^{n/2} n^{-1/2} \tau_X(n) \leq C 2^{n/2} n^{-1/p'}, \quad n \in \mathbb{N},$$

where $C = \kappa_{2,p} \tau_{p,X}$. Setting $n = \lceil C^{p'} e \rceil$, we find

$$\omega(2^n) \leq C 2^{n/2} n^{-1/p'} \leq 2^{n(\frac{1}{2} - \theta)} \quad (7.49)$$

with $\theta^{-1} = (C^{p'} e + 1)p' \log(2)$. The estimate (7.49) implies the following:

Corollary 7.6.14 (Hinrichs). *If X has type $p \in (1, 2]$, then*

$$\omega_X(2^k) \leq 2^{n(\frac{1}{2} - \theta)} 2^{k(\frac{1}{2} - \theta)}, \quad \text{for all } k \in \mathbb{N},$$

where $n = \lceil C^{p'} e \rceil$, $\theta^{-1} = (C^{p'} e + 1)p' \log(2)$ and $C = \kappa_{2,p} \tau_{p,X}$.

Moreover, X is K -convex with $K_{2,X} \leq C_{\alpha} 2^{n\alpha}$, where $\alpha = \frac{1}{2} - \theta$ and C_{α} is as in Theorem 7.6.12.

Proof. Let $j \in \mathbb{N}$ be such that $2^{nj} \leq 2^k < 2^{n(j+1)}$. Then by monotonicity, (7.48), and (7.49),

$$\omega_X(2^k) \leq \omega_X(2^{n(j+1)}) \leq \omega_X(2^n)^{j+1} \leq 2^{(j+1)n(\frac{1}{2} - \theta)} \leq 2^{(k+n)(\frac{1}{2} - \theta)}.$$

□

Walsh cotype 2

Similarly, the Walsh cotype 2 constant $\omega'_X(2^n)$ is defined as the least constant $\omega' \geq 0$ such that for all $(x_\alpha)_{\alpha \subseteq \{1, \dots, n\}}$ in X we have

$$\left(\sum_{\alpha} \|x_\alpha\|^2 \right)^{1/2} \leq \omega' \left\| \sum_{\alpha} w_\alpha x_\alpha \right\|_{L^2(D^n; X)}.$$

The following simple identity holds for the constants $\omega'_X(2^n)$. It can be viewed as an analogue of the corresponding fact for Fourier type on \mathbb{T}^d (see Proposition 2.4.20).

Proposition 7.6.15. *For any X and $n \in \mathbb{N}$, $\omega_X(2^n) = \omega'_X(2^n)$.*

Proof. In order to prove this we use a slightly different notation for the Walsh system. Define, for $a \in D^n = \{-1, 1\}^n$,

$$w_a(b) := \prod_{j=1}^n (-r_j(b))^{(a_j+1)/2}.$$

Then $(w_a)_{a \in D^n}$ is the Walsh system on $L^2(D^n)$. The advantage of this notation is that the identity $w_a(b) = w_b(a)$ holds for all $a, b \in \{-1, 1\}^n$. Indeed,

$$w_a(b) = \prod_{j=1}^n (-r_j(b))^{(a_j+1)/2} = \prod_{j=1}^n (-b_j)^{(a_j+1)/2} = \prod_{j=1}^n (-a_j)^{(b_j+1)/2} = w_b(a).$$

Let $(x_a)_{a \in D^n}$ in X be arbitrary and for each $b \in D^n$ let

$$y_b := \sum_{a \in \{-1, 1\}^n} w_a(b) x_a.$$

Then for all $c \in D^n$ one sees that (using $w_c(b) = w_b(c)$)

$$2^{-n} \sum_{b \in D^n} w_b(c) y_b = \sum_{a \in D^n} \left(2^{-n} \sum_{b \in D^n} w_c(b) w_a(b) \right) x_a = \sum_{a \in D^n} \langle w_c, w_a \rangle x_a = x_c.$$

It follows that

$$\begin{aligned} \left\| \sum_{a \in D^n} w_a x_a \right\|_2^2 &= 2^{-n} \sum_{b \in D^n} \|y_b\|^2 \\ &\leq \omega'_X(2^n)^2 2^{-n} \left\| \sum_{b \in D^n} w_b y_b \right\|_2^2 = \omega'_X(2^n)^2 \sum_{a \in D^n} \|x_a\|^2. \end{aligned}$$

This proves the inequality $\omega_X(2^n) \leq \omega'_X(2^n)$. The converse inequality can be proved similarly. \square

Arguing as in Proposition 7.3.6 (and using Proposition 7.6.15 in the cotype case) one shows that

$$\tau_X(2^n), c_X(2^n) \leq \omega_X(2^n). \quad (7.50)$$

By Kwapien's Theorem 7.3.1, this implies that $\sup_{n \in \mathbb{N}} \omega(2^n) < \infty$ if and only if X is isomorphic to a Hilbert space. From Lemma 7.3.17 together with (7.49) and (7.50) one deduces the following variant of Theorem 7.1.14 with slightly different constants:

Corollary 7.6.16. *If X has type $p \in (1, 2]$, then it has cotype q for all $q > (C^{p'}e + 1)p' \log(2)$, where $C = \kappa_{2,p}\tau_{p,X}$.*

Section 7.5

Pisier's contraction property was introduced in Pisier [1978b], where Theorem 7.5.20 was proved. In the subsequent literature, the name 'property (α) ' has become standard. We have tried to replace it with the more descriptive 'Pisier's contraction property'. What we call the triangular contraction property has been referred to as 'property (Δ) ' or 'weak (α) ' in the literature. Theorem 7.5.9 is due to Kalton and Weis [2001], where it was even shown that analytic UMD implies the triangular contraction property. The fact that $\mathcal{C}^1(\ell^2)$ does not have the triangular projection property (see Proposition 7.5.14) follows from the work of Haagerup and Pisier [1989]. The key result in the proof is the unboundedness of the triangular projection (see Lemma 7.5.12) which was shown by Kwapien and Pelczyński [1970].

The norm of the discrete Hilbert transform of Lemma 7.5.11 equals π ; this is a classical result of Schur [1911], which is also easy to extract from the argument presented here. A shorter proof of Proposition 7.5.15(1) can be found in Van Neerven and Weis [2008]. This proof does not give information on the constants and, more importantly, it cannot be adapted to prove the corresponding result for the triangular contraction property. Propositions 7.5.16 and 7.5.17(1) can be found in Kaip and Saal [2012].

Following Van Neerven and Weis [2008], the two separate estimates in (7.42), involving the constants $\alpha_X^\pm := \alpha_{2,X}^\pm$, can also be studied independently. The Gaussian versions of these constants, $\alpha_X^{\gamma,\pm}$ are defined analogously. Neither one of the two inequalities (7.42) holds in $X = c_0$, i.e.,

$$\alpha_{c_0}^- = \alpha_{c_0}^+ = \infty. \quad (7.51)$$

The proof of Proposition 7.5.18 shows that $\alpha_X^{\gamma,-} < \infty$ implies that X has finite cotype. As a consequence, $\alpha_{c_0}^{\gamma,-} = \infty$. A central limit theorem argument shows that also $\alpha_{c_0}^- = \infty$.

Example 7.6.17. To prove that $\alpha_{c_0}^+ = \infty$, let $N \geq 1$ be fixed and take $x_{mn} = \frac{1}{\sqrt{M}}e_n$, where e_n is the n th unit vector of ℓ_N^∞ . On the one hand we have, by the central limit theorem (see Section E.2.b), (E.10), and (E.11),

$$\begin{aligned} \lim_{M \rightarrow \infty} \mathbb{E} \left\| \sum_{m=1}^M \sum_{n=1}^N \varepsilon_{mn} x_{mn} \right\|_{\ell_N^\infty}^2 &= \lim_{M \rightarrow \infty} \mathbb{E} \left\| \sum_{n=1}^N \frac{1}{\sqrt{M}} \sum_{m=1}^M \varepsilon_{mn} e_n \right\|_{\ell_N^\infty}^2 \\ &= \mathbb{E} \left\| \sum_{n=1}^N \gamma_n e_n \right\|_{\ell_N^\infty}^2 \approx \log N, \end{aligned}$$

while on the other hand

$$\begin{aligned} \lim_{M \rightarrow \infty} \mathbb{E}' \mathbb{E}'' \left\| \sum_{m=1}^M \sum_{n=1}^N \varepsilon'_m \varepsilon''_n x_{mn} \right\|_{\ell_N^\infty}^2 &= \lim_{M \rightarrow \infty} \mathbb{E}' \mathbb{E}'' \left\| \sum_{n=1}^N \frac{1}{\sqrt{M}} \sum_{m=1}^M \varepsilon'_m \varepsilon''_n e_n \right\|_{\ell_N^\infty}^2 \\ &= \mathbb{E}' \mathbb{E}'' \left\| \sum_{n=1}^N \gamma' \varepsilon''_n e_n \right\|_{\ell_N^\infty}^2 \\ &= \mathbb{E}' |\gamma|^2 \mathbb{E}'' \left\| \sum_{n=1}^N \varepsilon''_n e_n \right\|_{\ell_N^\infty}^2 = 1. \end{aligned}$$

This implies $\alpha_{c_0}^+ \gtrsim \sqrt{\log(N)}$ for every $N \geq 1$ and hence $\alpha_{c_0}^+ = \infty$.

From Example 7.6.17 and Lemma 7.3.12 we deduce that $\alpha_{c_0}^{\gamma, -} = \alpha_{c_0}^{\gamma, +} = \infty$.

The following example has been observed in Van Neerven and Weis [2008] with a different proof:

Example 7.6.18. For $p \in (1, \infty)$, the Schatten class $\mathcal{C}^p = \mathcal{C}^p(\ell^2)$ satisfies

$$\begin{aligned} \alpha_{\mathcal{C}^p}^+ &< \infty && \text{if and only if } p \in [2, \infty), \\ \alpha_{\mathcal{C}^p}^- &< \infty && \text{if and only if } p \in (1, 2]. \end{aligned}$$

Proof. The “if” claims follow from the type or cotype 2 properties of \mathcal{C}^p (recorded in Proposition 7.1.11) and Proposition 7.6.22 below. On the other hand, we know from Proposition 7.5.6 that $\alpha_{\mathcal{C}^p} = \infty$ for all $p \neq 2$. From this, the “only if” claims actually follow from the “if” claims: whenever $\alpha_{\mathcal{C}^p}^\pm < \infty$ and $p \neq 2$, we must have $\alpha_{\mathcal{C}^p}^\mp = \infty$, since otherwise we would get $\alpha_{\mathcal{C}^p} \leq \alpha_{\mathcal{C}^p}^+ \alpha_{\mathcal{C}^p}^- < \infty$, a contradiction. \square

Example 7.6.18 shows that the separate study of the two inequalities in (7.42) is indeed meaningful, in that either of the two bounds may be true or false in a given Banach space independently of the other one.

The following result is obtained by repeating previous arguments and in particular using the Maurey–Pisier theorem to derive finite cotype from the finiteness of the corresponding constants α_X^\pm and $\alpha_X^{\gamma, \pm}$.

Proposition 7.6.19. *Let X be a Banach space.*

- (1) $\alpha_X^- < \infty$ if and only if $\alpha_X^{\gamma, -} < \infty$;
- (2) $\alpha_X^+ < \infty$ if and only if $\alpha_X^{\gamma, +} < \infty$.

If at least one of the conditions $\alpha_X^- < \infty$ or $\alpha_X^+ < \infty$ is satisfied, then X has finite cotype.

Combining this result with Theorem 7.5.20 we obtain:

Corollary 7.6.20. *For any Banach lattice X the following assertions are equivalent:*

- (1) X has Pisier's contraction property;
- (2) $\alpha_X^+ < \infty$;
- (3) $\alpha_X^- < \infty$;
- (4) X has finite cotype.

As we noted in Proposition 7.5.4, the constant $\alpha_{p,X}^\pm$ can be described as the optimal constants in the embeddings between $\varepsilon_{MN}(\varepsilon_N(X))$ and $\varepsilon_M(\varepsilon_N(X))$, i.e.,

$$\frac{1}{\alpha_{p,X}^+} \|\mathbf{x}\|_{\varepsilon_{MN}^p(X)} \leq \|\mathbf{x}\|_{\varepsilon_M^p(\varepsilon_N^p(X))} \leq \alpha_{p,X}^- \|\mathbf{x}\|_{\varepsilon_{MN}^p(X)}.$$

On the other hand, we recall from Theorem 7.4.14 that K -convexity allows us to identify $\varepsilon_N^p(X)^*$ and $\varepsilon_N^{p'}(X^*)$ so that

$$\|\mathbf{x}^*\|_{\varepsilon_N^{p'}(X^*)} \leq \|\mathbf{x}^*\|_{(\varepsilon_N^p(X))^*} \leq \|\mathbf{x}^*\|_{\varepsilon_N^{p'}(X^*)}.$$

These observations imply the following elaboration of Proposition 7.5.15 from Van Neerven and Weis [2008].

Proposition 7.6.21. *If X is a K -convex Banach space, then*

$$\alpha_{p',X^*}^+ \leq K_{p,X} \alpha_{p,X}^-, \quad \alpha_{p',X^*}^- \leq K_{p,X}^2 \alpha_{p,X}^+, \quad p \in (1, \infty).$$

Proof. Let $\mathbf{x}^* = (x_{mn}^*)_{m,n=1}^{M,N} \in X^{MN}$. Then

$$\begin{aligned} \|\mathbf{x}^*\|_{\varepsilon_{MN}^{p'}(X^*)} &\leq K_{p,X} \|\mathbf{x}^*\|_{(\varepsilon_{MN}^p(X))^*} = K_{p,X} \sup \left\{ |\langle \mathbf{x}, \mathbf{x}^* \rangle| : \|\mathbf{x}\|_{\varepsilon_{MN}^p(X)} \leq 1 \right\} \\ &\leq K_{p,X} \sup \left\{ |\langle \mathbf{x}, \mathbf{x}^* \rangle| : \|\mathbf{x}\|_{\varepsilon_M^p(\varepsilon_N^p(X))} \leq \alpha_{p,X}^- \right\} \\ &\leq K_{p,X} \alpha_{p,X}^- \|\mathbf{x}^*\|_{\varepsilon_M^{p'}(\varepsilon_N^{p'}(X^*))}, \end{aligned}$$

where the suprema are over all $\mathbf{x} = (x_{mn})_{m,n=1}^{M,N}$ with the specified norm constraint, and $\langle \mathbf{x}, \mathbf{x}^* \rangle = \sum_{m,n=1}^{M,N} \langle x_{mn}, x_{mn}^* \rangle$. Thus $\alpha_{p',X^*}^+ \leq K_{p,X} \alpha_{p,X}^-$.

Similarly,

$$\begin{aligned} \|\mathbf{x}^*\|_{\varepsilon_M^{p'}(\varepsilon_N^{p'}(X^*))} &\leq K_{p,X} \|\mathbf{x}^*\|_{\varepsilon_M^{p'}((\varepsilon_N^p(X))^*)} \leq K_{p,X} K_{p,\varepsilon_N^p(X)} \|\mathbf{x}^*\|_{(\varepsilon_M^p(\varepsilon_N^p(X)))^*} \\ &= K_{p,X}^2 \sup \left\{ |\langle \mathbf{x}, \mathbf{x}^* \rangle| : \|\mathbf{x}\|_{\varepsilon_M^p(\varepsilon_N^p(X))} \leq 1 \right\} \\ &\leq K_{p,X}^2 \sup \left\{ |\langle \mathbf{x}, \mathbf{x}^* \rangle| : \|\mathbf{x}\|_{\varepsilon_{MN}^p(X)} \leq \alpha_{p,X}^+ \right\} \\ &\leq K_{p,X}^2 \alpha_{p,X}^+ \|\mathbf{x}^*\|_{\varepsilon_{MN}^{p'}(X^*)}, \end{aligned}$$

which shows that $\alpha_{p',X^*}^- \leq K_{p,X}^2 \alpha_{p,X}^+$. □

The next result from [Van Neerven, Veraar, and Weis \[2015\]](#) establishes a simple relation between the one-sided Pisier contraction properties on the one hand and type and cotype 2 on the other.

Proposition 7.6.22. *Let X be a Banach space.*

- (1) *If X has cotype 2, then $\alpha_{2,X}^- \leq 4c_{2,X}^\gamma \sqrt{\log(2c_{2,X}^\gamma)}$ and $\alpha_{2,X}^{\gamma,-} \leq c_{2,X}^\gamma$*
(2) *If X has type 2, then $\alpha_{2,X}^+ \leq \|\gamma\|_1^{-1} \tau_{2,X}^\gamma$ and $\alpha_{2,X}^{\gamma,+} \leq \tau_{2,X}^\gamma$.*

where $c_{2,X}^\gamma$ and $\tau_{2,X}^\gamma$ are the Gaussian cotype 2 and type 2 constants of X .

Proof. (1): By the extremality of Gaussians among all orthonormal sequences under cotype 2 (Theorem 7.1.20 applied to the orthonormal sequence $\varepsilon'_m \varepsilon''_n$), and the comparability of Gaussians and Rademachers under the same condition (Corollary 7.1.23; the more general Corollary 7.2.10 would give the same result with a worse numerical factor), we have

$$\begin{aligned} \left\| \sum_{m=1}^M \sum_{n=1}^N \varepsilon'_m \varepsilon''_n x_{mn} \right\|_{L^2(\Omega; X)} &\leq c_{2,X}^\gamma \left\| \sum_{m=1}^M \sum_{n=1}^N \gamma_{mn} x_{mn} \right\|_{L^2(\Omega; X)} \\ &\leq c_{2,X}^\gamma \cdot 4 \sqrt{\log(2c_{2,X}^\gamma)} \left\| \sum_{m=1}^M \sum_{n=1}^N \varepsilon_{mn} x_{mn} \right\|_{L^2(\Omega; X)}, \end{aligned}$$

which proves the estimate for $\alpha_{2,X}^-$.

(2): By an application of the same results with the type 2 assumption (in this case, Corollary 7.1.23 can be replaced by the more elementary Proposition 6.1.15), we have

$$\begin{aligned} \left\| \sum_{m=1}^M \sum_{n=1}^N \varepsilon_{mn} x_{mn} \right\|_{L^2(\Omega; X)} &\leq \|\gamma\|_1^{-1} \left\| \sum_{m=1}^M \sum_{n=1}^N \gamma_{mn} x_{mn} \right\|_{L^2(\Omega; X)} \\ &\leq \|\gamma\|_1^{-1} \tau_{2,X}^\gamma \left\| \sum_{m=1}^M \sum_{n=1}^N \varepsilon'_m \varepsilon''_n x_{mn} \right\|_{L^2(\Omega; X)}, \end{aligned}$$

which proves the estimate for $\alpha_{2,X}^+$. The estimates for $\alpha_{2,X}^{\gamma,\pm}$ can be proved in a similar way. \square

Convexity and concavity of Banach lattices

In this paragraph we will indicate some connections between type and cotype on the one hand and some other notions on the other hand in the setting of Banach lattices. For details we refer to [Diestel, Jarchow, and Tonge \[1995\]](#) and [Lindenstrauss and Tzafriri \[1979\]](#).

Definition 7.6.23. *Let X be a Banach lattice and let $p, q \in [1, \infty)$.*

- (1) X is said to be p -convex if there exists a constant $C \geq 0$ such that for all finite sequences x_1, \dots, x_N in X we have

$$\left\| \left(\sum_{n=1}^N |x_n|^p \right)^{1/p} \right\| \leq C \left(\sum_{n=1}^N \|x_n\|^p \right)^{1/p}.$$

- (2) X is said to be q -concave if there exists a constant $c \geq 0$ such that for all finite sequences x_1, \dots, x_N in X we have

$$\left(\sum_{n=1}^N \|x_n\|^q \right)^{1/q} \leq c \left\| \left(\sum_{n=1}^N |x_n|^q \right)^{1/q} \right\|.$$

Theorem 7.6.24. *Let X be a Banach lattice and let $1 < p_0 < p \leq 2$ and $2 \leq q < q_0 < \infty$. The following assertions hold:*

- (1) if X is q -concave, then X has cotype q ;
- (2) if X is p -convex and q -concave, then X has type p ;
- (3) if X has type p , then X is p_0 -convex;
- (4) if X has cotype q , then X is q_0 -concave.

Part (4) has already been shown in Lemma 7.2.14. The other assertions can be proved by applying the Khintchine–Maurey inequality (Theorem 7.2.13).

When proving bounds for functions taking values in Banach function spaces, it is often possible to use p -convexity and q -concavity to reduce the vector-valued estimates to the corresponding estimates in the scalar-valued setting. By means of Kakutani's representation Theorem F.2.1 such results can often be extended to general Banach lattices. An example where this technique is used is the following basic observation due to García-Cuerva, Torrea, and Kazarian [1996, Proposition 2.2].

Proposition 7.6.25. *Let X be a Banach lattice and let $p \in (1, 2]$. If X is p -convex and p' -concave, then X has Fourier type p .*

In the same paper it is shown that this result fails for general Banach spaces if $p \in (1, 2)$ and X has type $p + \varepsilon$ and cotype $p' - \varepsilon$ for some $\varepsilon > 0$. The proof of Proposition 7.6.25 for Banach function spaces X applies the Hausdorff–Young inequality pointwise and then uses the p -convexity and q -concavity assumptions.

By replacing the assumption of cotype q in Theorem 7.2.6(2) by the stronger (according to Theorem 7.6.24) assumption of q -concavity, the limiting case $r = q$ can be covered:

Theorem 7.6.26. *Let $q \in [2, \infty)$ and let X be a q -concave Banach lattice. Then there exists a constant $C = C(q, X)$ such that for all finite sequences $(f_n)_{n=1}^N$ in $L^q(S)$ and $(x_n)_{n=1}^N$ in X ,*

$$\left\| \sum_{n=1}^N \varepsilon_n f_n x_n \right\|_{L^q(S \times \Omega; X)} \leq C \sup_{1 \leq n \leq N} \|f_n\|_{L^q(S)} \left\| \sum_{n=1}^N \varepsilon_n x_n \right\|_{L^q(\Omega; X)}. \quad (7.52)$$

Proof. Definition 7.6.23 implies the following integral version of q -concavity:

$$\|\phi\|_{L^q(S;X)} \leq C \left\| \left(\int_S |\phi|^q d\mu \right)^{1/q} \right\|_X,$$

where $\phi : S \rightarrow X$ is a simple function. To prove (7.52), by density it suffices to prove the estimate simple functions $f_1, \dots, f_N : S \rightarrow \mathbb{K}$ with $\|f_n\|_q \leq 1$. If X is a Banach function space, then by the above estimate and Minkowski's inequality,

$$\begin{aligned} \left\| \left(\sum_{n=1}^N |f_n x_n|^2 \right)^{1/2} \right\|_{L^q(S;X)} &\leq C \left\| \left(\int_S \left(\sum_{n=1}^N |f_n x_n|^2 \right)^{q/2} d\mu \right)^{1/q} \right\| \\ &\leq C \left\| \left(\sum_{n=1}^N \left(\int_S |f_n x_n|^q d\mu \right)^{2/q} \right)^{1/2} \right\| \\ &\leq C \left\| \left(\sum_{n=1}^N |x_n|^2 \right)^{1/2} \right\|. \end{aligned}$$

This implies the result for Banach lattice by Corollary F.2.2. Now the result follows if we combine the above estimate with the Khintchine–Maurey inequality (Theorem 7.2.13). \square

R-boundedness

In this chapter we continue the investigation of random series with vector-valued coefficients and we study the transformations of such series under the termwise action of families of bounded operators. As we will see, this provides us with an abstract framework that captures the essentials of many classical estimates in harmonic analysis and stochastic analysis.

More precisely, this chapter is about proving (and using) inequalities of the type

$$\begin{aligned} \left\| \sum_{n=1}^N \varepsilon_n T_n x_n \right\|_{L^2(\Omega; Y)} &\leq C \left\| \sum_{n=1}^N \varepsilon_n x_n \right\|_{L^2(\Omega; X)} \\ \left\| \sum_{n=1}^N \gamma_n T_n x_n \right\|_{L^2(\Omega; Y)} &\leq C \left\| \sum_{n=1}^N \gamma_n x_n \right\|_{L^2(\Omega; X)} \\ \left\| \left(\sum_{n=1}^N |T_n x_n|^2 \right)^{1/2} \right\|_Y &\leq C \left\| \left(\sum_{n=1}^N |x_n|^2 \right)^{1/2} \right\|_X, \end{aligned}$$

where in each case the operators T_n are drawn from some family $\mathcal{T} \subseteq \mathcal{L}(X, Y)$ of operators between two Banach spaces (or Banach lattices in the third inequality). If such inequalities hold, with a constant C independent of $N \geq 1$ and the choices of $x_1, \dots, x_N \in X$ and $T_1, \dots, T_N \in \mathcal{T}$, we call \mathcal{T} *R*-bounded, γ -bounded, or ℓ^2 -bounded, respectively. We have already encountered the notion of *R*-boundedness in Chapter 5, where it was instrumental in proving the operator-valued Mihlin multiplier theorem.

As it turns out, the three notions are equivalent in most common situations, although not in full generality. Even when equivalent, it is useful to have all three notions at hand. A key difference between the first two notions comes from the fact that products, but not sums, of independent Rademacher variables are again Rademacher variables, whereas sums, but not products, of independent Gaussian variables remain Gaussian. More subtly, the rotational invariance of Gaussian vectors in \mathbb{K}^d is at the heart of the proof of the

ideal property for γ -radonifying operators, to be proved in Chapter 9, which in turn provides us with a powerful tool in connection with R -boundedness and γ -boundedness questions.

All three notions are strongly linked with other questions studied in these volumes. R -boundedness offers a connection with unconditional convergence via the random signs provided by the Rademacher variables. γ -boundedness, in turn, is needed in the Gaussian context of stochastic integration with respect to Brownian motion. Finally, square functions are most convenient when pointwise estimates of functions are involved and in connection with methods of classical Fourier analysis and stochastic analysis. From the point of view of applications it is therefore essential to have a large supply of R -bounded sets, and indeed the theory abounds in interesting examples. To illustrate this, we list some concrete sets of operators which will be proved to be R -bounded:

- Multiplication operators $f \mapsto mf$ on $L^p(S; X)$, $1 \leq p < \infty$, with uniformly bounded symbols $m \in L^\infty(S)$.
- Semigroups of operators $f \mapsto e^{-tA}f$ on $L^p(\mathbb{R}^d; X)$, $1 < p < \infty$, where e^{-tA} is for example the heat semigroup $e^{t\Delta}$ or the Poisson semigroup $e^{-t(-\Delta)^{1/2}}$.
- Conditional expectation operators $f \mapsto \mathbb{E}(f|\mathcal{F}_k)$ on $L^p(S; X)$, $1 < p < \infty$, when the σ -algebras \mathcal{F}_k form an increasing sequence (a filtration).
- Fourier multipliers $f \mapsto T_m f$ on $L^p(\mathbb{R}; X)$, $1 < p < \infty$, when the symbols m satisfy the multiplier conditions $|m(\xi)|, |\xi m'(\xi)| \leq 1$ uniformly.

The first (easy) example is valid in the generality of arbitrary Banach spaces X , but the other three require UMD and, in the last case, also Pisier's contraction property, hinting at the interesting connections of R -boundedness with the properties of Banach spaces that we have investigated so far. Many more examples will be encountered throughout this text.

8.1 Basic theory

Throughout this chapter, X and Y are Banach spaces, $(\varepsilon_n)_{n \geq 1}$ is a Rademacher sequence and $(\gamma_n)_{n \geq 1}$ a Gaussian sequence on a fixed probability space (Ω, \mathbb{P}) . We remind the reader of the convention, used throughout the book, that both Rademacher and Gaussian variables are understood to be real if we work over the real scalar field and complex when we work over the complex scalars.

8.1.a Definition and comparison with related notions

We begin our discussion by recalling the Kahane contraction principle (Theorem 6.1.13). It asserts that for all $1 \leq p < \infty$ and scalar sequences $(a_n)_{n=1}^N$ we have

$$\left\| \sum_{n=1}^N a_n \xi_n x_n \right\|_{L^p(\Omega; X)} \leq \left(\sup_{1 \leq n \leq N} |a_n| \right) \left\| \sum_{n=1}^N \xi_n x_n \right\|_{L^p(\Omega; X)}$$

regardless the choice of vectors x_1, \dots, x_N from X , when ξ_1, \dots, ξ_N is an independent sequence of either Rademacher or Gaussian random variables. In many situations one needs an analogous inequality in which the scalars a_n are replaced by bounded operators T_n from X into a possibly different Banach space Y . This leads to the following definition.

Definition 8.1.1. *Let X and Y be Banach spaces and consider a family of operators $\mathcal{T} \subseteq \mathcal{L}(X, Y)$.*

- (1) \mathcal{T} is said to be R -bounded if there exists a constant $C \geq 0$ such that for all finite sequences $(T_n)_{n=1}^N$ in \mathcal{T} and $(x_n)_{n=1}^N$ in X ,

$$\left\| \sum_{n=1}^N \varepsilon_n T_n x_n \right\|_{L^2(\Omega; Y)} \leq C \left\| \sum_{n=1}^N \varepsilon_n x_n \right\|_{L^2(\Omega; X)}.$$

- (2) \mathcal{T} is said to be γ -bounded if there exists a constant $C \geq 0$ such that for all finite sequences $(T_n)_{n=1}^N$ in \mathcal{T} and $(x_n)_{n=1}^N$ in X ,

$$\left\| \sum_{n=1}^N \gamma_n T_n x_n \right\|_{L^2(\Omega; Y)} \leq C \left\| \sum_{n=1}^N \gamma_n x_n \right\|_{L^2(\Omega; X)}.$$

- (3) If X and Y are Banach lattices, then \mathcal{T} is said to be ℓ^2 -bounded if there exists a constant $C \geq 0$ such that for all finite sequences $(T_n)_{n=1}^N$ in \mathcal{T} and $(x_n)_{n=1}^N$ in X ,

$$\left\| \left(\sum_{n=1}^N |T_n x_n|^2 \right)^{1/2} \right\|_Y \leq C \left\| \left(\sum_{n=1}^N |x_n|^2 \right)^{1/2} \right\|_X.$$

In all three definitions, the stated inequalities are assumed to hold for finite sequences on any length. The least admissible constants in the inequalities are called the R -bound, the γ -bound, and the ℓ^2 -bound of \mathcal{T} and denoted by $\mathcal{R}(\mathcal{T})$, $\gamma(\mathcal{T})$, and $\ell^2(\mathcal{T})$, respectively.

It is often convenient to extend the definition of the bounds $\mathcal{R}(\mathcal{T})$, $\gamma(\mathcal{T})$, $\ell^2(\mathcal{T})$ to arbitrary families of operators \mathcal{T} , declaring the bounds to take the value ∞ when \mathcal{T} fails the respective boundedness property.

Remark 8.1.2. If in (1) we replace $L^2(\Omega; Y)$ by $L^p(\Omega; Y)$ and $L^2(\Omega; X)$ by $L^q(\Omega; X)$, we obtain an equivalent definition of R -boundedness, but with a possibly different best constant that we denote by $\mathcal{R}_{p,q}(\mathcal{T})$. It follows from the Kahane–Khintchine inequality (Theorem 6.2.4) that $\mathcal{R}_{p,q}(\mathcal{T}) \leq \kappa_{p,2} \mathcal{R}(\mathcal{T}) \kappa_{2,q}$ and $\mathcal{R}(\mathcal{T}) \leq \kappa_{2,p} \mathcal{R}_{p,q}(\mathcal{T}) \kappa_{q,2}$. The same remark applies to (2). Especially in the context of L^p -spaces (of both scalar and vector-valued functions), it is often convenient to work with $\mathcal{R}_p(\mathcal{T}) := \mathcal{R}_{p,p}(\mathcal{T})$ and $\gamma_p(\mathcal{T}) := \gamma_{p,p}(\mathcal{T})$.

The principal relations between these different notions and that of uniform boundedness are summarised in the following:

Theorem 8.1.3. *Let X and Y be Banach spaces and let \mathcal{T} be a family of operators in $\mathcal{L}(X, Y)$. Then R -boundedness of \mathcal{T} implies γ -boundedness, which implies uniform boundedness, and for all $p \in [1, \infty)$ we have*

$$\sup_{T \in \mathcal{T}} \|T\| \leq \gamma_p(\mathcal{T}) \leq \mathcal{R}_p(\mathcal{T}).$$

Furthermore,

- (1) *if Y has type 2 and X has cotype 2 (in particular if $X = Y$ is a Hilbert space), then R -boundedness, γ -boundedness and uniform boundedness are all equivalent, and*

$$\sup_{T \in \mathcal{T}} \|T\| \leq \mathcal{R}(\mathcal{T}) \leq \tau_{2,Y} c_{2,X} \sup_{T \in \mathcal{T}} \|T\|;$$

- (2) *if X has finite cotype $q \in [2, \infty)$, then R -boundedness and γ -boundedness are equivalent, and*

$$\gamma_q(\mathcal{T}) \leq \mathcal{R}_q(\mathcal{T}) \leq \|\gamma\|_1^{-1} A_{q,X}^\gamma \gamma_q(\mathcal{T}),$$

where $A_{q,X}^\gamma \leq 12\sqrt{q \log(80\sqrt{q}c_{q,X}^\gamma)}$ is the constant of Corollary 7.2.10;

- (3) *if X and Y are Banach lattices with finite cotype $q \in [2, \infty)$ (in particular, if they are L^p -spaces with $p \in [1, \infty)$), then R -boundedness, γ -boundedness and ℓ^2 -boundedness are all equivalent, and*

$$\left(\frac{5}{4}\pi^2 \kappa_{2,1}^{\mathbb{R}} \sqrt{q} c_{q,Y}\right)^{-1} \mathcal{R}_1(\mathcal{T}) \leq \ell^2(\mathcal{T}) \leq \frac{5}{4}\pi^2 \kappa_{2,1}^{\mathbb{R}} \sqrt{q} c_{q,X} \mathcal{R}_1(\mathcal{T}).$$

Each one of the two bounds requires the cotype of only one of the spaces, as evident from the formula.

It is known that the Kahane–Khintchine constant $\kappa_{2,1}^{\mathbb{R}}$ in part (3) equals $\sqrt{2}$; cf. the Notes of Chapter 6.

In both (1) and (2), the assumptions on the spaces are also necessary for the conclusions. We return to these converse implications in Proposition 8.6.1 and Theorem 8.6.4.

Proof. The estimate $\sup_{T \in \mathcal{T}} \|T\| \leq \gamma_p(\mathcal{T})$ follows by considering $N = 1$ in the definition of γ -boundedness; after cancelling $\|\gamma_1\|_p$ from both sides, this reduces to $\|T_1 x_1\| \leq \gamma(\mathcal{T}) \|x_1\|$.

In order to prove that $\gamma_p(\mathcal{T}) \leq \mathcal{R}_p(\mathcal{T})$, we may assume that $(\varepsilon_n)_{n \geq 1}$ and $(\gamma_n)_{n \geq 1}$ are defined on distinct probability spaces, to be distinguished by a subscript. Then for all $T_1, \dots, T_N \in \mathcal{T}$ and $x_1, \dots, x_N \in X$, by randomising (Proposition 6.1.11) and Fubini's theorem we obtain

$$\begin{aligned} \mathbb{E}_\gamma \left\| \sum_{n=1}^N \gamma_n T_n x_n \right\|^p &= \mathbb{E}_\gamma \mathbb{E}_r \left\| \sum_{n=1}^N \varepsilon_n \gamma_n T_n x_n \right\|^p \\ &\leq \mathcal{R}_p(\mathcal{T})^p \mathbb{E}_\gamma \mathbb{E}_r \left\| \sum_{n=1}^N \varepsilon_n \gamma_n x_n \right\|^p = \mathcal{R}_p(\mathcal{T})^p \mathbb{E}_\gamma \left\| \sum_{n=1}^N \gamma_n x_n \right\|^p, \end{aligned}$$

which proves the required estimate.

(1): With $M := \sup_{T \in \mathcal{T}} \|T\|$ we have

$$\begin{aligned} \mathbb{E} \left\| \sum_{n=1}^N \varepsilon_n T_n x_n \right\|^2 &\leq \tau_{2,Y}^2 \sum_{n=1}^N \|T_n x_n\|^2 \\ &\leq \tau_{2,Y}^2 M^2 \sum_{n=1}^N \|x_n\|^2 \leq \tau_{2,Y}^2 c_{2,X}^2 M^2 \mathbb{E} \left\| \sum_{n=1}^N \varepsilon_n x_n \right\|^2. \end{aligned}$$

(2): By Corollaries 6.1.17 and 7.2.10 we have

$$\begin{aligned} \left\| \sum_{n=1}^N \varepsilon_n T_n x_n \right\|_{L^q(\Omega; X)} &\leq \frac{1}{\|\gamma\|_1} \left\| \sum_{n=1}^N \gamma_n T_n x_n \right\|_{L^q(\Omega; X)} \\ &\leq \frac{1}{\|\gamma\|_1} \gamma_q(\mathcal{T}) \left\| \sum_{n=1}^N \gamma_n x_n \right\|_{L^q(\Omega; X)} \leq \frac{1}{\|\gamma\|_1} A_{q,X}^\gamma \gamma_q(\mathcal{T}) \left\| \sum_{n=1}^N \varepsilon_n x_n \right\|_{L^p(\Omega; X)}. \end{aligned}$$

(3): By Proposition 6.1.19 and the Khintchine–Maurey inequality (Theorem 7.2.13),

$$\begin{aligned} \left\| \left(\sum_{n=1}^N |T_n x_n|^2 \right)^{1/2} \right\|_Y &\leq \kappa_{2,1}^{\mathbb{R}} \left\| \sum_{n=1}^N r_n T_n x_n \right\|_{L^1(\Omega; Y)} \\ &\leq \frac{1}{2} \pi \kappa_{2,1}^{\mathbb{R}} \left\| \sum_{n=1}^N \varepsilon_n T_n x_n \right\|_{L^1(\Omega; Y)} \\ &\leq \frac{1}{2} \pi \kappa_{2,1}^{\mathbb{R}} \mathcal{R}_1(\mathcal{T}) \left\| \sum_{n=1}^N \varepsilon_n x_n \right\|_{L^1(\Omega; X)} \\ &\leq \frac{1}{4} \pi^2 \kappa_{2,1}^{\mathbb{R}} \mathcal{R}_1(\mathcal{T}) \left\| \sum_{n=1}^N r_n x_n \right\|_{L^1(\Omega; X)} \\ &\leq \frac{5}{4} \pi^2 \kappa_{2,1}^{\mathbb{R}} \sqrt{q} c_{q,X} \mathcal{R}_1(\mathcal{T}) \left\| \left(\sum_{n=1}^N |x_n|^2 \right)^{1/2} \right\|. \end{aligned}$$

The proof of the other inequality is similar. Thus ℓ^2 -boundedness is equivalent to R -boundedness, which is equivalent to γ -boundedness by (2). \square

Remark 8.1.4. In the important special case $X = L^p(S)$ and $Y = L^q(T)$, the bounds in (3) of Theorem 8.1.3 can be simplified to

$$\frac{1}{\kappa_{q,2}\kappa_{2,p}} \mathcal{R}_{q,p}(\mathcal{T}) \leq \ell^2(\mathcal{T}) \leq \kappa_{2,q}\kappa_{p,2} \mathcal{R}_{q,p}(\mathcal{T}).$$

This follows easily from the classical Khintchine inequality and Fubini's theorem, without the more advanced Theorem 7.2.13; indeed,

$$\begin{aligned} \left\| \left(\sum_{n=1}^N |T_n x_n|^2 \right)^{1/2} \right\|_{L^q(T)} &\leq \kappa_{2,q} \left\| \sum_{n=1}^N \varepsilon_n T_n x_n \right\|_{L^q(\Omega \times T)} \\ &\leq \kappa_{2,q} \mathcal{R}_{q,p}(\mathcal{T}) \left\| \sum_{n=1}^N \varepsilon_n x_n \right\|_{L^p(\Omega \times S)} \\ &\leq \kappa_{2,q} \mathcal{R}_{q,p}(\mathcal{T}) \kappa_{p,2} \left\| \left(\sum_{n=1}^N |x_n|^2 \right)^{1/2} \right\|_{L^p(S)}, \end{aligned}$$

showing that $\ell^2(\mathcal{T}) \leq \kappa_{2,q}\kappa_{p,2} \mathcal{R}_{q,p}(\mathcal{T})$. The other inequality is proved in a similar way.

For the rest of this chapter we will develop the theory of R -boundedness and leave it to the reader to verify that, apart from those instances where the contrary is explicitly stated, it is possible to replace the ε_n 's by γ_n 's to obtain counterparts in terms of γ -boundedness, with the same estimates for the γ -bounds. In the context of L^p -spaces, we will also develop some techniques in the framework of ℓ^2 -boundedness but, due to the equivalence just established, mostly refer to it also as R -boundedness.

8.1.b Testing R -boundedness with distinct operators

Despite the largely analogous theories of R -boundedness and γ -boundedness, we start with an important property of R -boundedness, whose truth or falsity for γ -boundedness presents an open problem. This is the possibility of restricting the quantifiers in the definition of R -boundedness to all possible choices of *distinct* operators T_1, \dots, T_N only. Being allowed to do so is sometimes convenient in concrete situations.

Proposition 8.1.5. *A family \mathcal{T} of operators in $\mathcal{L}(X, Y)$ is R -bounded if and only if for some (equivalently, for all) $1 \leq p < \infty$ there exists a constant $C \geq 0$ such that for all $N \geq 1$, all $T_1, \dots, T_N \in \mathcal{T}$ satisfying*

$$T_i \neq T_j \text{ whenever } i \neq j,$$

and all $x_1, \dots, x_N \in X$ we have

$$\mathbb{E} \left\| \sum_{n=1}^N \varepsilon_n T_n x_n \right\|^p \leq C^p \mathbb{E} \left\| \sum_{n=1}^N \varepsilon_n x_n \right\|^p.$$

In this situation $\mathcal{R}_p(\mathcal{T})$ equals the least admissible constant C in the above estimate.

Proof. We only need to prove the ‘if’ part and the bound $\mathcal{R}_p(\mathcal{T}) \leq C$.

Fix arbitrary operators $T_1, \dots, T_N \in \mathcal{T}$. Let $S_1, \dots, S_K \in \mathcal{T}$ be distinct operators with $\{S_k : 1 \leq k \leq K\} = \{T_n : 1 \leq n \leq N\}$. Write $\{1, \dots, N\}$ as a disjoint union $\bigcup_{k=1}^K I_k$ by grouping the indices corresponding to the same operator, i.e., let $I_k = \{n : T_n = S_k\}$. Let $(\varepsilon'_n)_{n \geq 1}$ be a Rademacher sequence on a distinct probability space (Ω', \mathbb{P}') . Let $\xi_k = \sum_{n \in I_k} \varepsilon_n x_n$ for $k = 1, \dots, K$. Then ξ_1, \dots, ξ_K are independent and symmetric X -valued random variables, and by randomisation we obtain

$$\begin{aligned} \mathbb{E} \left\| \sum_{n=1}^N \varepsilon_n T_n x_n \right\|^p &= \mathbb{E} \left\| \sum_{k=1}^K S_k \xi_k \right\|^p = \mathbb{E} \mathbb{E}' \left\| \sum_{k=1}^K \varepsilon'_k S_k \xi_k \right\|^p \\ &\leq C_p^p \mathbb{E} \mathbb{E}' \left\| \sum_{k=1}^K \varepsilon'_k \xi_k \right\|^p = C_p^p \mathbb{E} \left\| \sum_{k=1}^K \xi_k \right\|^p = C_p^p \mathbb{E} \left\| \sum_{n=1}^N \varepsilon_n x_n \right\|^p. \end{aligned}$$

□

Corollary 8.1.6. For a sequence $(T_n)_{n \geq 1}$ of operators in $\mathcal{L}(X, Y)$ the following assertions are equivalent:

- (1) the family $\{T_n : n \geq 1\}$ is R -bounded;
- (2) for some (equivalently, for all) $1 \leq p < \infty$ there exists a constant $C \geq 0$ such that for all $N \geq 1$ and all $x_1, \dots, x_N \in X$,

$$\mathbb{E} \left\| \sum_{n=1}^N \varepsilon_n T_n x_n \right\|^p \leq C^p \mathbb{E} \left\| \sum_{n=1}^N \varepsilon_n x_n \right\|^p.$$

In this situation, $\mathcal{R}(\{T_n : n \geq 1\})$ equals the least admissible constant C in assertion (2).

Proof. We only need to prove that (2) implies (1) with $\mathcal{R}_p(\{T_n : n \geq 1\}) \leq C$.

Fix arbitrary operators $S_1, \dots, S_M \in \{T_n : n \geq 1\}$. By Proposition 8.1.5 we may assume that $S_i \neq S_j$ whenever $i \neq j$. Choose $N \geq 1$ so large that $\{S_1, \dots, S_M\} \subseteq \{T_1, \dots, T_N\}$. For each m , let $n(m)$ be the first index such that $S_m = T_{n(m)}$. Fix arbitrary x_1, \dots, x_M and define $y_n = x_m$ if $n = n(m)$ and set $y_n = 0$ for all remaining n . Then, for Rademacher sequences $(\varepsilon_m)_{m=1}^M$ and $(\varepsilon'_n)_{n=1}^N$,

$$\mathbb{E} \left\| \sum_{m=1}^M \varepsilon_m S_m x_m \right\|^p = \mathbb{E}' \left\| \sum_{n=1}^N \varepsilon'_n T_n y_n \right\|^p$$

$$\leq C^p \mathbb{E}' \left\| \sum_{n=1}^N \varepsilon'_n y_n \right\|^p = C^p \mathbb{E} \left\| \sum_{m=1}^M \varepsilon_m x_m \right\|^p.$$

□

8.1.c First examples: multiplication and averaging operators

Example 8.1.7. Every singleton $\{T\}$ in $\mathcal{L}(X, Y)$ is both R -bounded and γ -bounded and $\mathcal{R}(\{T\}) = \gamma(T) = \|T\|$.

The corresponding result on ℓ^2 -boundedness is more subtle: every singleton $\{T\}$ is ℓ^2 -bounded with $\ell^2(\{T\}) \leq K_G \|T\|$, where K_G is the so-called Grothendieck constant (see the Notes at the end of the chapter).

Another immediate example of R -boundedness is provided by the Kahane contraction principle:

Example 8.1.8. For any Banach space X the family $\mathcal{I}_X := \{cI_X : |c| \leq 1\}$ is R -bounded and $\mathcal{R}_p(\mathcal{I}_X) = 1$ for all $1 \leq p < \infty$.

This bootstraps via Fubini's theorem into the following, which we may also occasionally refer to as the 'contraction principle' in the sequel.

Example 8.1.9 (R -boundedness of L^∞ -multipliers on L^p). Let (S, \mathcal{A}, μ) be a measure space and let $1 \leq p < \infty$. For a function $m \in L^\infty(S)$ define the bounded multiplier $M_m \in \mathcal{L}(L^p(S; X))$ by

$$(M_m f)(s) := m(s)f(s), \quad s \in S.$$

Then the set $\mathcal{M} = \{M_m : \|m\|_\infty \leq 1\}$ is R -bounded and $\mathcal{R}_p(\mathcal{M}) \leq 1$.

Indeed, by Fubini's theorem (the use of which is justified by Proposition 1.1.15) and the Kahane contraction principle,

$$\begin{aligned} \mathbb{E} \left\| \sum_{n=1}^N \varepsilon_n M_{m_n} f_n \right\|_{L^p(S; X)}^p &= \int_S \mathbb{E} \left\| \sum_{n=1}^N \varepsilon_n m_n(\xi) f_n(\xi) \right\|^p d\mu(\xi) \\ &\leq \int_S \mathbb{E} \left\| \sum_{n=1}^N \varepsilon_n f_n(\xi) \right\|^p d\mu(\xi) \\ &= \mathbb{E} \left\| \sum_{n=1}^N \varepsilon_n f_n \right\|_{L^p(S; X)}^p. \end{aligned}$$

This example cannot be extended to $p = \infty$. Indeed, let $f_1 = \dots = f_N = \mathbf{1}$, the constant one function on the unit interval $(0, 1)$. Let $(\phi_n)_{n \geq 0}$ be a sequence of Rademacher functions on $(0, 1)$. Then, by Lemma 6.1.20,

$$\mathbb{E} \left\| \sum_{n=1}^N \varepsilon_n f_n \right\|_{L^\infty(0,1; X)}^2 = N, \quad \mathbb{E} \left\| \sum_{n=1}^N \varepsilon_n \phi_n f_n \right\|_{L^\infty(0,1; X)}^2 = N^2.$$

This may serve to explain why we exclude the exponent $p = \infty$ when discussing R -boundedness issues.

The same basic principle of contraction also gives R -bounds for families of operators suitably dominated by a single operator. Other instances of the same phenomenon will appear later in the chapter.

Proposition 8.1.10 (Domination by a linear operator). *Let $(S_1, \mathcal{A}_1, \mu_1)$ and $(S_2, \mathcal{A}_2, \mu_2)$ be measure spaces and let $1 \leq p, q < \infty$. If $U : L^p(S_1) \rightarrow L^q(S_2)$ is a positive operator, then*

$$\mathcal{T}_U := \{T \in \mathcal{L}(L^p(S_1), L^q(S_2)) : |Tf| \leq U|f| \text{ for all } f \in L^p(S_1)\}$$

is R -bounded, and

$$\mathcal{R}_{q,p}(\mathcal{T}_U) \leq \kappa_{q,p} \|U\|.$$

Proof. We use the contraction principle, applied with the bounded functions $T_n f_n / U|f_n|$ (with, say, $0/0 := 0$) together with the linearity and boundedness of U , the Kahane–Khintchine inequality and the contraction principle with $|f_n|/f_n$, to estimate

$$\begin{aligned} \left\| \sum_{n=1}^N \varepsilon_n T_n f_n \right\|_{L^q(\Omega \times S_2)} &\leq \left\| \sum_{n=1}^N \varepsilon_n U|f_n| \right\|_{L^q(\Omega \times S_2)} \\ &\leq \|U\| \left\| \sum_{n=1}^N \varepsilon_n |f_n| \right\|_{L^q(\Omega; L^p(S_1))} \\ &\leq \|U\| \kappa_{q,p} \left\| \sum_{n=1}^N \varepsilon_n |f_n| \right\|_{L^p(\Omega \times S_1)} \\ &\leq \|U\| \kappa_{q,p} \left\| \sum_{n=1}^N \varepsilon_n f_n \right\|_{L^p(\Omega \times S_1)}. \end{aligned}$$

□

Remark 8.1.11. If U is an integral operator given by

$$Uf(s) := \int_{S_1} u(s, t) f(t) \, d\mu_1(t),$$

with non-negative kernel u , then the collection \mathcal{T}_U contains in particular all integral operators of the form

$$Tf(s) := \int_{S_1} k(s, t) f(t) \, d\mu_1(t)$$

with $|k(s, t)| \leq u(s, t)$.

Averaging operators

The second basic source of R -boundedness is the process of averaging, which we first discuss in a probabilistic set-up. We recall from Section 2.6 that the conditional expectation operator $f \mapsto \mathbb{E}(f|\mathcal{A}')$, where $\mathcal{A}' \subseteq \mathcal{A}$ is a σ -finite sub- σ -algebra, are positive contractions on the spaces $L^p(S)$, $1 \leq p \leq \infty$, and can be extended to contractions on the spaces $L^p(S; X)$ for any Banach space X . We have also proved in Theorem 4.2.23 an inequality which can be neatly restated in the language of R -boundedness:

Theorem 8.1.12 (Stein's inequality on R -boundedness of conditional expectations). *Let X be a UMD space and let $1 < p < \infty$. Let $(\mathcal{A}_n)_{n \in \mathbb{Z}}$ be a σ -finite filtration in a measure space (S, \mathcal{A}, μ) . Then the family $\mathcal{E} = \{\mathbb{E}(\cdot|\mathcal{A}_n) : n \in \mathbb{Z}\}$ of conditional expectations is R -bounded on $L^p(S; X)$ and*

$$\mathcal{R}_p(\mathcal{E}) \leq \beta_{p,X}^+,$$

where $\beta_{p,X}^+$ is the one-sided UMD-constant of X from Proposition 4.2.3.

Proof. We proved in Theorem 4.2.23 that

$$\left\| \sum_{n=1}^N \varepsilon_n \mathbb{E}(f_n|\mathcal{A}_n) \right\|_{L^p(S \times \Omega; X)} \leq \beta_{p,X}^+ \left\| \sum_{n=1}^N \varepsilon_n f_n \right\|_{L^p(S \times \Omega; X)},$$

and by re-indexing our filtration, we can start the sum from $n = -M$ instead of $n = 1$. With M, N arbitrary, this gives the R -boundedness inequality for any choice of finitely many distinct operators from \mathcal{E} , which by Proposition 8.1.5 gives the full R -boundedness. (Alternatively, we could also achieve the repetition by applying the Stein inequality as stated to a new filtration, where some of the σ -algebras are repeated.) \square

With the help of Theorem 8.1.12 we can also obtain a similar bound for more 'geometric' averaging operators over Euclidean balls:

Proposition 8.1.13 (R -boundedness of averaging operators). *Let X be a UMD space and $1 < p < \infty$. The family \mathcal{A} of all averaging operators*

$$f \mapsto A_B f := \left(\frac{1}{|B|} \int_B f(x) dx \right) \mathbf{1}_B,$$

where B runs over all balls in \mathbb{R}^d , is R -bounded on $L^p(\mathbb{R}^d; X)$, and

$$\mathcal{R}_p(\mathcal{A}) \leq c_d \beta_{p,X}^+.$$

Proof. Let us write $f_B = \frac{1}{|B|} \int_B f$ for the average over B . We need to estimate

$$\left\| \sum_{n=1}^N \varepsilon_n \mathbf{1}_{B_n} \int_{B_n} f_n dx \right\|_{L^p(\mathbb{R}^d; X)}.$$

We recall the covering Lemma 3.2.26 which states that for every axes-parallel cube $Q \subseteq \mathbb{R}^d$, there exists a ‘dyadic’ cube D in one of 3^d ‘dyadic systems’ \mathcal{D}^α , $\alpha \in \{0, \frac{1}{3}, \frac{2}{3}\}^d$, such that $\ell(Q) \leq 3\ell(D)$, where ℓ denotes the side-length of the cubes. For the present purposes, it is not necessary to recall the precise description of the ‘dyadic systems’ \mathcal{D}^α (although the interested reader will find all the details around the cited covering Lemma 3.2.26); it is enough to know that $\mathcal{D}^\alpha = \cup_{j \in \mathbb{Z}} \mathcal{D}_j^\alpha$, where each \mathcal{D}_j^α is the set of atoms of an atomic σ -algebra $\mathcal{F}_j^\alpha := \sigma(\mathcal{D}_j^\alpha)$, where $(\mathcal{F}_j^\alpha)_{j \in \mathbb{Z}}$ is a filtration of \mathbb{R}^d . If $D \in \mathcal{D}_j^\alpha$, we note that $f_D g$ is the constant value of $\mathbb{E}(g | \mathcal{F}_j^\alpha)$ on the atom D .

For each B_n , let $Q_n \supseteq B_n$ with $\ell(Q_n) = \text{diam}(B_n)$ be the minimal axes-parallel cube containing it, and $D_n \supseteq Q_n$ a containing dyadic cube with $\ell(D_n) \leq 3\ell(Q_n) = 3 \text{diam}(B_n)$ in some $\mathcal{D}_{j_n}^{\alpha_n}$, as provided by the Covering Lemma just discussed.

We observe that

$$\mathbf{1}_{B_n} \int_{B_n} f_n \, dx = \frac{|D_n|}{|B_n|} \mathbf{1}_{B_n} \int_{D_n} f_n \, dx = \frac{|D_n|}{|B_n|} \mathbf{1}_{B_n} \mathbb{E}(\mathbf{1}_{B_n} f_n | \mathcal{F}_{j_n}^{\alpha_n}).$$

Note that

$$\frac{|D_n|}{|B_n|} = \frac{|D_n|}{|Q_n|} \frac{|Q_n|}{|B_n|} \leq 3^d \frac{2^d}{|B^d|} =: c'_d,$$

where $|B^d|$ is the volume of the unit ball in \mathbb{R}^d .

With these preparations, the main argument proceeds as

$$\begin{aligned} & \left\| \sum_{n=1}^N \varepsilon_n \mathbf{1}_{B_n} \int_{B_n} f_n \, dx \right\|_{L^p(\mathbb{R}^d; X)} \\ &= \left\| \sum_{n=1}^N \varepsilon_n \frac{|D_n|}{|B_n|} \mathbf{1}_{B_n} \mathbb{E}(\mathbf{1}_{B_n} f_n | \mathcal{F}_{j_n}^{\alpha_n}) \right\|_{L^p(\mathbb{R}^d; X)} \\ &\leq c'_d \sum_{\alpha \in \{0, \frac{1}{3}, \frac{2}{3}\}^d} \left\| \sum_{n: \alpha_n = \alpha} \varepsilon_n \mathbb{E}(\mathbf{1}_{B_n} f_n | \mathcal{F}_{j_n}^\alpha) \right\|_{L^p(\mathbb{R}^d; X)} \\ &\leq c'_d \sum_{\alpha \in \{0, \frac{1}{3}, \frac{2}{3}\}^d} \beta_{p, X}^+ \left\| \sum_{n: \alpha_n = \alpha} \varepsilon_n \mathbf{1}_{B_n} f_n \right\|_{L^p(\mathbb{R}^d; X)} \\ &\leq c'_d 3^d \beta_{p, X}^+ \left\| \sum_{n=1}^N \varepsilon_n f_n \right\|_{L^p(\mathbb{R}^d; X)}, \end{aligned}$$

where the first and third estimates were applications of the R -boundedness of the L^∞ -multipliers of Example 8.1.9 with $m_n = \frac{|D_n|}{|B_n|} \mathbf{1}_{B_n}$ and $m_n = \mathbf{1}_{\{m: \alpha_m = \alpha\}}(n) \mathbf{1}_{B_n}$, while the second estimate was the R -boundedness of conditional expectation from Theorem 8.1.12. We have proved the proposition with $c_d = c'_d 3^d = 18^d |B^d|^{-1}$. \square

Tensor extensions

Let $(S_1, \mathcal{A}_1, \mu_1)$ and $(S_2, \mathcal{A}_2, \mu_2)$ be measure spaces. By the extension theorem of Paley and Marcinkiewicz–Zygmund (Theorem 2.1.9), when H is a Hilbert space and $1 \leq p, q < \infty$, every bounded operator from $L^p(S_1)$ to $L^q(S_2)$ extends to a bounded operator from $L^p(S_1; H)$ to $L^q(S_2; H)$. The next proposition considers the extension of R -bounded sets of operators from $L^p(S_1)$ to $L^q(S_2)$.

Proposition 8.1.14 (H -valued extensions). *Let H be a Hilbert space and $1 \leq p, q < \infty$. If $\mathcal{T} \subseteq \mathcal{L}(L^p(S_1), L^q(S_2))$ is R -bounded, then $\mathcal{T} \otimes I_H := \{T \otimes I_H : T \in \mathcal{T}\} \subseteq \mathcal{L}(L^p(S_1; H), L^q(S_2; H))$ is R -bounded and*

$$\mathcal{R}_{q,p}(\mathcal{T} \otimes I_H) \leq \kappa_{q,p}^\gamma \frac{\|\gamma\|_p}{\|\gamma\|_q} \mathcal{R}_{q,p}(\mathcal{T}).$$

Proof. Let $(\gamma_m)_{m \geq 1}$ and $(\varepsilon'_n)_{n \geq 1}$ be a Gaussian sequence and a Rademacher sequence on distinct probability spaces (Ω, \mathbb{P}) and (Ω', \mathbb{P}') , respectively. Let $(h_m)_{m=1}^M$ be an orthonormal system in H . Observe that for all sequences of scalars $(\alpha_m)_{m=1}^M$, the following identity holds (see (2.3)):

$$\|\gamma\|_q \left\| \sum_{m=1}^M \alpha_m h_m \right\|_H = \left\| \sum_{m=1}^M \alpha_m \gamma_m \right\|_{L^q(\Omega)}.$$

Fix functions $F_1, \dots, F_N \in L^p(S_1; H)$ of the form $F_n := \sum_{m=1}^M f_{mn} \otimes h_m$ and put $G_n := \sum_{m=1}^M f_{mn} \gamma_m$. By the observation, pointwise on $\Omega' \times S$ we have

$$\|\gamma\|_q \left\| \sum_{n=1}^N \varepsilon'_n (T_n \otimes I_H) F_n \right\|_H = \left\| \sum_{n=1}^N \varepsilon'_n T_n G_n \right\|_{L^q(\Omega)}.$$

Therefore, taking $L^q(\Omega'; L^q(S_2; H))$ -norms, after interchanging the integrals the R -boundedness of \mathcal{T} implies

$$\begin{aligned} \|\gamma\|_q & \left\| \sum_{n=1}^N \varepsilon'_n (T_n \otimes I_H) F_n \right\|_{L^q(\Omega'; L^q(S_2; H))} \\ & = \left\| \sum_{n=1}^N \varepsilon'_n T_n G_n \right\|_{L^q(\Omega'; L^q(S_2; L^q(\Omega)))} \\ & = \left\| \sum_{n=1}^N \varepsilon'_n T_n G_n \right\|_{L^q(\Omega; L^q(\Omega'; L^q(S_2)))} \\ & \leq \mathcal{R}_{q,p}(\mathcal{T}) \left\| \sum_{n=1}^N \varepsilon'_n G_n \right\|_{L^q(\Omega; L^p(\Omega'; L^q(S_1)))} \end{aligned}$$

$$\leq \mathcal{R}_{q,p}(\mathcal{T})\kappa_{q,p}^\gamma \left\| \sum_{n=1}^N \varepsilon'_n G_n \right\|_{L^p(\Omega; L^p(\Omega'; L^q(S_1)))},$$

using the Kahane–Khintchine inequality for Gaussian sums in the last step. Finally, by performing the same calculation in the reverse direction,

$$\left\| \sum_{n=1}^N \varepsilon'_n G_n \right\|_{L^p(\Omega; L^p(\Omega'; L^q(S_1)))} = \|\gamma\|_p \left\| \sum_{n=1}^N \varepsilon'_n F_n \right\|_{L^p(\Omega'; L^q(S_1; H))}.$$

This proves the required estimate for functions F_1, \dots, F_N of the form specified above. Since such functions form a dense subspace of $L^p(S_1; H)$, the estimate extends to arbitrary F_1, \dots, F_N in $L^p(S_1; H)$. \square

With regard to the simple extension Theorem 2.1.3 one may ask whether a similar R -boundedness result holds: If \mathcal{T} is an R -bounded family of positive operators on $L^p(S)$, is the family of tensor extensions $\mathcal{T}_X = \{T \otimes I_X : T \in \mathcal{T}\}$ R -bounded on $L^p(S; X)$? The next example shows that for $1 < p < \infty$, the R -boundedness of \mathcal{T}_X implies the triangular contraction property. Therefore the question has a negative answer for Banach spaces failing this property, such as c_0 and $\mathcal{C}^1(\ell^2)$ (see Corollary 7.5.13 and Proposition 7.5.14).

Example 8.1.15. Let $(\varepsilon_n)_{n \geq 1}$ and $(\varepsilon'_m)_{m \geq 1}$ be Rademacher sequences on distinct probability spaces (Ω, \mathbb{P}) and (Ω', \mathbb{P}') , respectively. For $n \geq 1$ let $\mathcal{F}_n = \sigma(\varepsilon_1, \dots, \varepsilon_n)$ and $T_n = \mathbb{E}(\cdot | \mathcal{F}_n)$. Then each T_n is a positive operator and by Theorem 8.1.12, the family $\{T_n : n \geq 1\}$ is R -bounded on $L^p(\Omega)$ for any $p \in (1, \infty)$, with R -bound at most $\beta_{p, L^p(\Omega)}^+ \leq \beta_{p, \mathbb{K}} = p^* - 1$ (see Chapter 4). Now let X be any Banach space and suppose the family $\mathcal{T}_X := \{T_n \otimes I_X : n \geq 1\}$ is R -bounded. Then, with $f_n := \sum_{m=1}^N r_m x_{mn}$ where $(x_{mn})_{m,n=1}^N$ is a doubly indexed sequence in X ,

$$\begin{aligned} \left\| \sum_{n=1}^N \sum_{m=1}^n r'_n r_m x_{mn} \right\|_{L^p(\Omega \times \Omega'; X)} &= \left\| \sum_{n=1}^N r'_n (T_n \otimes I_X) f_n \right\|_{L^p(\Omega \times \Omega'; X)} \\ &\leq \mathcal{R}(\mathcal{T}_X) \left\| \sum_{n=1}^N r'_n f_n \right\|_{L^p(\Omega \times \Omega'; X)} \\ &= \mathcal{R}(\mathcal{T}_X) \left\| \sum_{n=1}^N \sum_{m=1}^N r'_n r_m x_{mn} \right\|_{L^p(\Omega \times \Omega'; X)}. \end{aligned}$$

This means that X has the triangular contraction property.

We conclude this section with an explicit example of a uniformly bounded family which fails to be R -bounded:

Proposition 8.1.16. *Let X be a non-zero Banach space, let $1 \leq p \leq \infty$, and let $(S(t))_{t \in \mathbb{R}}$ denote the left-translation group on $L^p(\mathbb{R}; X)$. The following assertions are equivalent:*

- (1) the family of extensions $(S(t) \otimes I_X)_{t \in \mathbb{R}}$ is R -bounded on $L^p(\mathbb{R}; X)$;
- (2) the family of extensions $(S(t) \otimes I_X)_{t \in \mathbb{R}}$ is γ -bounded on $L^p(\mathbb{R}; X)$;
- (3) $p = 2$ and X is isomorphic to a Hilbert space.

Proof. The implications (1) \Rightarrow (2) and (3) \Rightarrow (1) follow from the observations, already made, that R -boundedness implies γ -boundedness, and that both notions are equivalent to uniform boundedness in Hilbert spaces. It thus remains to prove the implication (2) \Rightarrow (3).

We begin by showing that (2) implies $p = 2$. By considering only Gaussian sums with values in a given one-dimensional subspace of X , it suffices to consider the case $X = \mathbb{K}$.

First assume that $p \in (2, \infty]$. Let u_1, \dots, u_N be distinct real numbers and let $f \in L^p(\mathbb{R})$ be an arbitrary function of norm one whose support is contained in an interval of length not exceeding $\min_{1 \leq i \neq j \leq N} |u_i - u_j|$. With $f_n := S(-u_n)f$ we have

$$\mathbb{E} \left\| \sum_{n=1}^N \gamma_n S(u_n) f_n \right\|_{L^p(\mathbb{R})}^2 = \mathbb{E} \left\| \sum_{n=1}^N \gamma_n f \right\|_{L^p(\mathbb{R})}^2 = N.$$

On the other hand, Hölder's inequality, the disjointness of the supports of the functions f_n , and Khintchine's inequality imply

$$\mathbb{E} \left\| \sum_{n=1}^N \gamma_n f_n \right\|_{L^p(\mathbb{R})}^2 \leq \left(\mathbb{E} \left\| \sum_{n=1}^N \gamma_n f_n \right\|_{L^p(\mathbb{R})}^p \right)^{2/p} \approx_p \left(\sum_{n=1}^N \|f_n\|^p \right)^{2/p} = N^{2/p}.$$

If $p = \infty$, the disjointness assumption implies

$$\mathbb{E} \left\| \sum_{n=1}^N \gamma_n f_n \right\|_{L^\infty(\mathbb{R})}^2 \leq \mathbb{E} \left(\sup_{1 \leq n \leq N} |\gamma_n|^2 \right) \lesssim 2 \log(2N)$$

using Proposition E.2.21. In both cases, comparing these inequalities we see that the family $(S(t))_{t \in \mathbb{R}}$ cannot be R -bounded on $L^p(\mathbb{R})$.

The case $p \in [1, 2)$ can be handled similarly. Indeed, by the Kahane–Khintchine inequality,

$$\mathbb{E} \left\| \sum_{n=1}^N \gamma_n S(-u_n) f \right\|_{L^p(\mathbb{R})}^2 = \mathbb{E} \left\| \sum_{n=1}^N \gamma_n f_n \right\|_{L^p(\mathbb{R})}^2 \approx_p N^{2/p},$$

whereas

$$\mathbb{E} \left\| \sum_{n=1}^N \gamma_n f \right\|_{L^p(\mathbb{R})}^2 = N.$$

This again shows that $(S(t))_{t \in \mathbb{R}}$ cannot be R -bounded on $L^p(\mathbb{R})$. This concludes the proof that (2) implies $p = 2$.

Next we show that (2) implies that X is isomorphic to a Hilbert space. We will actually deduce from (2) that X has both type 2 and cotype 2; the conclusion then follows by an appeal to Kwapien’s theorem (Theorem 7.3.1).

We have already seen that (2) forces $p = 2$. Let u_1, \dots, u_N be finitely many distinct real numbers, let $f \in L^2(\mathbb{R})$ be an arbitrary function of norm one whose support is contained in an interval of length not exceeding $\min_{1 \leq i \neq j \leq N} |u_i - u_j|$, and let $x_1, \dots, x_N \in X$ be arbitrary. With $g_n := S(-u_n)f \otimes x_n$ we have

$$\mathbb{E} \left\| \sum_{n=1}^N \gamma_n S(u_n) g_n \right\|_{L^2(\mathbb{R}; X)}^2 = \mathbb{E} \left\| \sum_{n=1}^N \gamma_n (f \otimes x_n) \right\|_{L^2(\mathbb{R}; X)}^2 = \mathbb{E} \left\| \sum_{n=1}^N \gamma_n x_n \right\|_X^2,$$

whereas, on the other hand, the disjointness of the supports of the functions g_n implies that

$$\mathbb{E} \left\| \sum_{n=1}^N \gamma_n g_n \right\|_{L^2(\mathbb{R}; X)}^2 = \sum_{n=1}^N \|g_n\|_{L^2(\mathbb{R}; X)}^2 = \sum_{n=1}^N \|x_n\|^2.$$

Comparing these equalities, we see that the γ -boundedness of the operators $S(u) \otimes I_X$ implies that X has (Gaussian) type 2. The proof that X has (Gaussian) cotype 2 is proved by a similar modification of the arguments as in the first part of the proof. \square

8.1.d R -boundedness versus boundedness on $\varepsilon_N^p(X)$

The following elementary reformulation of R -boundedness in the language of the Rademacher spaces introduced in Section 6.3 is surprisingly useful in many applications:

Proposition 8.1.17. *Let X and Y be Banach spaces. A family $\mathcal{T} \subseteq \mathcal{L}(X, Y)$ is R -bounded with constant $\mathcal{R}_p(\mathcal{T}) \leq C$ if and only if every finite sequence $(T_n)_{n=1}^N$ in \mathcal{T} determines a bounded operator \tilde{T} of norm $\|\tilde{T}\| \leq C$ from $\varepsilon_N^p(X)$ to $\varepsilon_N^p(Y)$ through the action*

$$\tilde{T} : (x_n)_{n=1}^N \mapsto (T_n x_n)_{n=1}^N.$$

Under an additional assumption on the Banach spaces, the uniform boundedness of the operators \tilde{T} of the previous remark bootstraps into R -boundedness of these operators:

Proposition 8.1.18. *Let X and Y be Banach spaces with Pisier’s contraction property, and $\mathcal{T} \subseteq \mathcal{L}(X, Y)$ be an R -bounded family. For any given $N \geq 1$, let $\tilde{\mathcal{T}}_N$ be the family of all operators in $\varepsilon_N^p(X) \rightarrow \varepsilon_N^p(Y)$ of the form*

$$\tilde{T} : (x_n)_{n=1}^N \mapsto (T_n x_n)_{n=1}^N,$$

where $(T_n)_{n=1}^N \subseteq \mathcal{T}$. Then $\widetilde{\mathcal{T}}_N$ is R -bounded, and

$$\mathcal{R}_p(\widetilde{\mathcal{T}}_N) \leq \alpha_{p,X}^+ \alpha_{p,Y}^- \mathcal{R}_p(\mathcal{T}).$$

Proof. With $\widetilde{T}_k = (T_{kn})_{n=1}^N \in \widetilde{\mathcal{T}}_N$ and $\widetilde{x}_k = (x_{kn})_{n=1}^N \in \varepsilon_N^p(X)$ we have

$$\begin{aligned} \left\| \sum_{k=1}^K \varepsilon_k \widetilde{T}_k \widetilde{x}_k \right\|_{L^p(\Omega; \varepsilon_N^p(Y))} &= \left\| \sum_{k=1}^K \varepsilon_k \sum_{n=1}^N \varepsilon'_n T_{kn} x_{kn} \right\|_{L^p(\Omega \times \Omega'; Y)} \\ &\leq \alpha_{p,Y}^- \left\| \sum_{k=1}^K \sum_{n=1}^N \varepsilon_{kn} T_{kn} x_{kn} \right\|_{L^p(\Omega; Y)} \\ &\leq \alpha_{p,Y}^- \mathcal{R}_p(\mathcal{T}) \left\| \sum_{k=1}^K \sum_{n=1}^N \varepsilon_{kn} x_{kn} \right\|_{L^p(\Omega; X)} \\ &\leq \alpha_{p,Y}^- \mathcal{R}_p(\mathcal{T}) \alpha_{p,X}^+ \left\| \sum_{k=1}^K \varepsilon_k \sum_{n=1}^N \varepsilon'_n x_{kn} \right\|_{L^p(\Omega \times \Omega'; X)} \\ &= \alpha_{p,Y}^- \mathcal{R}_p(\mathcal{T}) \alpha_{p,X}^+ \left\| \sum_{k=1}^K \varepsilon_k \widetilde{x}_k \right\|_{L^p(\Omega; \varepsilon_N^p(X))}, \end{aligned}$$

where $\alpha_{p,X}^+$ and $\alpha_{p,X}^-$ denote the least admissible constants in (7.42). \square

8.1.e Stability of R -boundedness under set operations

We record some simple facts about the stability of R -boundedness under various algebraic manipulations. As a direct consequence of the definitions one sees that

Proposition 8.1.19 (Unions, sums, products). *Let X, Y, Z be Banach spaces and $1 \leq p < \infty$.*

(1) *If $\mathcal{S} \subseteq \mathcal{T} \subseteq \mathcal{L}(X, Y)$ and \mathcal{T} is R -bounded, then so is \mathcal{S} and*

$$\mathcal{R}_p(\mathcal{S}) \leq \mathcal{R}_p(\mathcal{T}).$$

(2) *If $\mathcal{S} \subseteq \mathcal{L}(X, Y)$ and $\mathcal{T} \subseteq \mathcal{L}(X, Y)$ are R -bounded, then the families $\mathcal{S} \cup \mathcal{T}$ and $\mathcal{S} + \mathcal{T} = \{S + T : S \in \mathcal{S}, T \in \mathcal{T}\}$, are R -bounded and*

$$\begin{aligned} \mathcal{R}_p(\mathcal{S} + \mathcal{T}) &\leq \mathcal{R}_p(\mathcal{S}) + \mathcal{R}_p(\mathcal{T}), \\ \mathcal{R}_p(\mathcal{S} \cup \mathcal{T}) &\leq \mathcal{R}_p(\mathcal{S}) + \mathcal{R}_p(\mathcal{T}). \end{aligned}$$

(3) *If $\mathcal{S} \subseteq \mathcal{L}(X, Y)$ and $\mathcal{T} \subseteq \mathcal{L}(Y, Z)$ are R -bounded, then the family $\mathcal{T}\mathcal{S} = \{TS : S \in \mathcal{S}, T \in \mathcal{T}\}$ is R -bounded and*

$$\mathcal{R}_p(\mathcal{T}\mathcal{S}) \leq \mathcal{R}_p(\mathcal{S})\mathcal{R}_p(\mathcal{T}).$$

Proof. (1): This is clear from the definition of R -boundedness.

(2): Let $\mathcal{S}, \mathcal{T} \in \mathcal{L}(X, Y)$. The inequality $\mathcal{R}_p(\mathcal{S} + \mathcal{T}) \leq \mathcal{R}_p(\mathcal{S}) + \mathcal{R}_p(\mathcal{T})$ is a trivial consequence of the triangle inequality in $L^p(\Omega; X)$. Then, by Kahane’s contraction principle,

$$\begin{aligned} \mathcal{R}_p(\mathcal{S} \cup \mathcal{T}) &\leq \mathcal{R}_p((\mathcal{S} \cup \{0\}) + (\mathcal{T} \cup \{0\})) \\ &\leq \mathcal{R}_p(\mathcal{S} \cup \{0\}) + \mathcal{R}_p(\mathcal{T} \cup \{0\}) = \mathcal{R}_p(\mathcal{S}) + \mathcal{R}_p(\mathcal{T}). \end{aligned}$$

(3): Let $T_1 S_1, \dots, T_N S_N \in \mathcal{T}$ and $x_1, \dots, x_N \in X$. Then

$$\begin{aligned} \left\| \sum_{n=1}^N \varepsilon_n T_n S_n x_n \right\|_{L^p(\Omega; Z)} &\leq \mathcal{R}_p(\mathcal{T}) \left\| \sum_{n=1}^N \varepsilon_n S_n x_n \right\|_{L^p(\Omega; Y)} \\ &\leq \mathcal{R}_p(\mathcal{T}) \mathcal{R}_p(\mathcal{S}) \left\| \sum_{n=1}^N \varepsilon_n x_n \right\|_{L^p(\Omega; X)}. \end{aligned}$$

□

As an immediate generalisation, if $(\mathcal{T}_k)_{k \geq 1}$ is a sequence of R -bounded sets in $\mathcal{L}(X, Y)$ whose R -bounds are summable, then the union $\mathcal{T} = \bigcup_{k \geq 1} \mathcal{T}_k$ is R -bounded, with R -bound

$$\mathcal{R}_p(\mathcal{T}) \leq \sum_{k \geq 1} \mathcal{R}_p(\mathcal{T}_k)$$

for all $1 \leq p < \infty$. This elementary observation can be refined if we make use of the cotype and type properties of X and Y , respectively. For $p = 1$ and $q = \infty$ we recover the aforementioned result, while the other extreme case $p = q = 2$ and $r = \infty$ reduces, via Kwapien’s theorem, to the assertion that every uniformly bounded sequence of Hilbert space operators is R -bounded.

Proposition 8.1.20. *Suppose that X has cotype $q \in [2, \infty]$ and Y has type $p \in [1, 2]$. Let $(\mathcal{T}_k)_{k \geq 1}$ be a sequence of R -bounded families in $\mathcal{L}(X, Y)$ and suppose that the sequence of R -bounds $(\mathcal{R}_p(\mathcal{T}_k))_{k \geq 1}$ belongs to ℓ^r , where $\frac{1}{r} = \frac{1}{p} - \frac{1}{q}$. Then the union $\mathcal{T} := \bigcup_{k \geq 1} \mathcal{T}_k$ is R -bounded and*

$$\mathcal{R}_{p,q}(\mathcal{T}) \leq \tau_{p,Y} c_{q,X} \|(\mathcal{R}_p(\mathcal{T}_k))_{k \geq 1}\|_{\ell^r}.$$

Proof. We prove this for $q \in [2, \infty)$ and $r \in [1, \infty)$, the cases $q = \infty$ and $r = \infty$ being similar and simpler.

Upon replacing \mathcal{T}_{n+1} by $\mathcal{T}_{n+1} \setminus \bigcup_{m=1}^n \mathcal{T}_m$, we may assume that the families \mathcal{T}_n are disjoint.

Fix $N \geq 1$ and choose arbitrary operators $T_1, \dots, T_N \in \mathcal{T}$. For each $k \geq 1$ set $I_k^N = \{1 \leq n \leq N : T_n \in \mathcal{T}_k\}$ and note that at most finitely many of these sets are non-empty. Randomising with an independent Rademacher sequence $(\varepsilon'_n)_{n \geq 1}$, using Hölder’s inequality with exponents r/p and $r/(r-p) = q/p$ we obtain (with obvious changes if $q = \infty$)

$$\begin{aligned}
\mathbb{E} \left\| \sum_{n=1}^N \varepsilon_n T_n x_n \right\|^p &= \mathbb{E} \mathbb{E}' \left\| \sum_{k \geq 1} \varepsilon'_k \sum_{n \in I_k^N} \varepsilon_n T_n x_n \right\|^p \\
&\leq \tau_{p,Y}^p \sum_{k \geq 1} \mathbb{E} \left\| \sum_{n \in I_k^N} \varepsilon_n T_n x_n \right\|^p \\
&\leq \tau_{p,Y}^p \sum_{k \geq 1} \mathcal{R}_p(\mathcal{T}_k)^p \mathbb{E} \left\| \sum_{n \in I_k^N} \varepsilon_n x_n \right\|^p \\
&\leq \tau_{p,Y}^p \left(\sum_{k \geq 1} \mathcal{R}_p(\mathcal{T}_k)^r \right)^{p/r} \left(\mathbb{E} \sum_{k \geq 1} \left\| \sum_{n \in I_k^N} \varepsilon_n x_n \right\|^q \right)^{p/q} \\
&\leq \tau_{p,Y}^p c_{q,X}^p \left(\sum_{k \geq 1} \mathcal{R}_p(\mathcal{T}_k)^r \right)^{p/r} \left(\mathbb{E} \mathbb{E}' \left\| \sum_{k \geq 1} \varepsilon'_k \sum_{n \in I_k^N} \varepsilon_n x_n \right\|^q \right)^{p/q} \\
&= \tau_{p,Y}^p c_{q,X}^p \left(\sum_{k \geq 1} \mathcal{R}_p(\mathcal{T}_k)^r \right)^{p/r} \left(\mathbb{E} \left\| \sum_{n=1}^N \varepsilon_n x_n \right\|^q \right)^{p/q}.
\end{aligned}$$

□

Convex hulls

Among the most useful properties of R -boundedness is its interplay with convexity.

Proposition 8.1.21 (Convex hull). *If \mathcal{T} is R -bounded in $\mathcal{L}(X, Y)$, then the convex hull and the absolute convex hull of \mathcal{T} are R -bounded in $\mathcal{L}(X, Y)$. Moreover,*

$$\mathcal{R}_p(\mathcal{T}) = \mathcal{R}_p(\text{conv}(\mathcal{T})) = \mathcal{R}_p(\text{abs conv}(\mathcal{T})).$$

Proof. We begin with the proof concerning the convex hull. Choose operators $S_1, \dots, S_N \in \text{conv}(\mathcal{T})$. Recalling from Lemma 3.2.13 that

$$\text{conv}(\mathcal{T}) \times \dots \times \text{conv}(\mathcal{T}) = \text{conv}(\mathcal{T} \times \dots \times \mathcal{T}),$$

we can find $\lambda_1, \dots, \lambda_k \in [0, 1]$ with $\sum_{j=1}^k \lambda_j = 1$ such that $S_n = \sum_{j=1}^k \lambda_j T_{jn}$ with $T_{jn} \in \mathcal{T}$ for all $j = 1, \dots, k$ and $n = 1, \dots, N$. Then, for all $x_1, \dots, x_N \in X$,

$$\begin{aligned}
\mathbb{E} \left\| \sum_{n=1}^N \varepsilon_n S_n x_n \right\|_{L^p(\Omega; Y)} &\leq \sum_{j=1}^k \lambda_j \left\| \sum_{n=1}^N \varepsilon_n T_{jn} x_n \right\|_{L^p(\Omega; Y)} \\
&\leq \mathcal{R}_p(\mathcal{T}) \sum_{j=1}^k \lambda_j \left\| \sum_{n=1}^N \varepsilon_n x_n \right\|_{L^p(\Omega; X)} \\
&= \mathcal{R}_p(\mathcal{T}) \left\| \sum_{n=1}^N \varepsilon_n x_n \right\|_{L^p(\Omega; X)}.
\end{aligned}$$

This proves the R -boundedness of $\text{conv}(\mathcal{T})$ with the estimate $\mathcal{R}_p(\text{conv}(\mathcal{T})) \leq \mathcal{R}_p(\mathcal{T})$. The opposite inequality $\mathcal{R}_p(\mathcal{T}) \leq \mathcal{R}_p(\text{conv}(\mathcal{T}))$ is trivial.

By the contraction principle the set $\mathcal{T}' := \{\lambda T : T \in \mathcal{T}, |\lambda| \leq 1\}$ is R -bounded and $\mathcal{R}_p(\mathcal{T}') = \mathcal{R}_p(\mathcal{T})$. Since $\text{conv} \mathcal{T}' = \text{abs conv} \mathcal{T}'$, the result for the absolute convex hull follows from this. \square

Topological closures

For the next result we recall that the *weak operator topology* on $\mathcal{L}(X, Y)$ is the topology generated by the sets of the form

$$\{S \in \mathcal{L}(X, Y) : |\langle (S - T)x, y^* \rangle| < \varepsilon\}$$

with $T \in \mathcal{L}(X, Y)$, $x \in X$, $y^* \in Y^*$, and $\varepsilon > 0$. Similarly, the *strong operator topology* on $\mathcal{L}(X, Y)$ is the topology generated by the sets of the form

$$\{S \in \mathcal{L}(X, Y) : \|(S - T)x\| < \varepsilon\}$$

with $T \in \mathcal{L}(X, Y)$, $x \in X$, and $\varepsilon > 0$.

It is easy to check that $\lim_{n \rightarrow \infty} T_n = T$ in the weak (respectively, strong) operator topology if and only if $\lim_{n \rightarrow \infty} \langle T_n x, y^* \rangle = \langle T x, y^* \rangle$ for all $x \in X$ and $y^* \in Y^*$ (respectively, $\lim_{n \rightarrow \infty} T_n x = T x$ for all $x \in X$).

Proposition 8.1.22 (Weak and strong operator topology closures). *If $\mathcal{T} \subseteq \mathcal{L}(X, Y)$ is R -bounded, then its closures $\overline{\mathcal{T}}^{\text{wo}}$ and $\overline{\mathcal{T}}^{\text{so}}$ in the weak and strong operator topologies are R -bounded, and for all $1 \leq p < \infty$ we have*

$$\mathcal{R}_p(\overline{\mathcal{T}}^{\text{wo}}) = \mathcal{R}_p(\overline{\mathcal{T}}^{\text{so}}) = \mathcal{R}_p(\mathcal{T}).$$

Proof. The assertion concerning the strong operator topology follows from the corresponding assertion for the weak operator topology. As the strong case is simpler to prove, for the convenience of the reader we include a proof for this case as well.

Let $\overline{T}_1, \dots, \overline{T}_N \in \overline{\mathcal{T}}^{\text{so}}$ and $x_1, \dots, x_N \in X$ be arbitrary. Fix an arbitrary $\varepsilon > 0$. Choose operators $T_1, \dots, T_N \in \mathcal{T}$ such that for all $n = 1, \dots, N$,

$$\|\overline{T}_n x_n - T_n x_n\| < 2^{-n} \varepsilon, \quad n = 1, \dots, N.$$

Then,

$$\begin{aligned} \left\| \sum_{n=1}^N \varepsilon_n \overline{T}_n x_n \right\|_{L^p(\Omega; Y)} &\leq \left\| \sum_{n=1}^N \varepsilon_n T_n x_n \right\|_{L^p(\Omega; Y)} + \sum_{n=1}^N \|\overline{T}_n x_n - T_n x_n\| \\ &\leq \mathcal{R}_p(\mathcal{T}) \left\| \sum_{n=1}^N \varepsilon_n x_n \right\|_{L^p(\Omega; X)} + \varepsilon. \end{aligned}$$

Since the choice of $\varepsilon > 0$ was arbitrary, this proves that $\overline{\mathcal{T}}^{\text{so}}$ is R -bounded with $\mathcal{R}_p(\overline{\mathcal{T}}^{\text{so}}) \leq \mathcal{R}_p(\mathcal{T})$. The converse inequality is trivial.

To prove the assertion for the closure in the weak operator topology we argue similarly. Let $\bar{T}_1, \dots, \bar{T}_N \in \overline{\mathcal{T}}^{\text{wo}}$ and $x_1, \dots, x_N \in X$ be arbitrary. Fix an arbitrary $\varepsilon > 0$. Let $\frac{1}{p} + \frac{1}{p'} = 1$ and fix a simple function $g \in L^{p'}(\Omega; Y^*)$ of norm one, say $g = \sum_{j=1}^k \mathbf{1}_{\Omega_j} \otimes y_j^*$ with the sets $\Omega_j \in \mathcal{F}$ disjoint. Choose operators $T_1, \dots, T_N \in \mathcal{T}$ such that for all $n = 1, \dots, N$,

$$|\langle \bar{T}_n x_n - T_n x_n, y_j^* \rangle| < 2^{-n} \varepsilon, \quad j = 1, \dots, k.$$

Then

$$\mathbb{E} |\langle \bar{T}_n x_n - T_n x_n, g \rangle| = \mathbb{E} \sum_{j=1}^k \mathbf{1}_{\Omega_j} |\langle \bar{T}_n x_n - T_n x_n, y_j^* \rangle| \leq 2^{-n} \varepsilon \sum_{j=1}^k \mathbb{E} \mathbf{1}_{\Omega_j} = 2^{-n} \varepsilon$$

and therefore

$$\begin{aligned} \mathbb{E} \left| \left\langle \sum_{n=1}^N \varepsilon_n \bar{T}_n x_n, g \right\rangle \right| &\leq \mathbb{E} \left| \left\langle \sum_{n=1}^N \varepsilon_n T_n x_n, g \right\rangle \right| + \sum_{n=1}^N \mathbb{E} |\langle \bar{T}_n x_n - T_n x_n, g \rangle| \\ &\leq \left(\mathbb{E} \left\| \sum_{n=1}^N \varepsilon_n T_n x_n \right\|^p \right)^{1/p} + \sum_{n=1}^N 2^{-n} \varepsilon \\ &\leq \mathcal{R}_p(\mathcal{T}) \left(\mathbb{E} \left\| \sum_{n=1}^N \varepsilon_n x_n \right\|^p \right)^{1/p} + \varepsilon. \end{aligned}$$

Upon taking the supremum over all simple functions g of norm one in $L^{p'}(\Omega; Y^*)$ and applying Proposition 1.3.1 we obtain the estimate

$$\left(\mathbb{E} \left\| \sum_{n=1}^N \varepsilon_n \bar{T}_n x_n \right\|^p \right)^{1/p} \leq \mathcal{R}_p(\mathcal{T}) \left(\mathbb{E} \left\| \sum_{n=1}^N \varepsilon_n x_n \right\|^p \right)^{1/p} + \varepsilon.$$

Since the choice of $\varepsilon > 0$ was arbitrary, this proves that $\overline{\mathcal{T}}^{\text{wo}}$ is R -bounded with $\mathcal{R}_p(\overline{\mathcal{T}}^{\text{wo}}) \leq \mathcal{R}_p(\mathcal{T})$. The converse inequality is trivial. \square

In the same way as above one proves that if $\mathcal{T} \subseteq \mathcal{L}(Y^*, X^*)$ is R -bounded, then its closure $\overline{\mathcal{T}}^{\text{wo}^*}$ in the weak* operator topology is R -bounded and $\mathcal{R}_p(\overline{\mathcal{T}}^{\text{wo}^*}) = \mathcal{R}_p(\mathcal{T})$ for all $1 \leq p < \infty$.

Remark 8.1.23. The R -boundedness of the closure in the weak operator can alternatively be deduced from the R -boundedness of the closure in the strong operator topology and the Hahn-Banach theorem. For $\mathcal{S} := \text{conv} \mathcal{T}$, by Proposition B.2.4 we have $\overline{\mathcal{S}}^{\text{so}} = \overline{\mathcal{S}}^{\text{wo}}$ and therefore, by Proposition 8.1.21,

$$\mathcal{R}_p(\overline{\mathcal{T}}^{\text{wo}}) \leq \mathcal{R}_p(\overline{\mathcal{S}}^{\text{wo}}) = \mathcal{R}_p(\overline{\mathcal{S}}^{\text{so}}) = \mathcal{R}_p(\mathcal{S}) = \mathcal{R}_p(\mathcal{T}).$$

The reverse estimate $\mathcal{R}_p(\mathcal{T}) \leq \mathcal{R}_p(\overline{\mathcal{T}}^{\text{wo}})$ is obvious.

As a first application we prove:

Proposition 8.1.24. *Let I be an index set, and let for each $i \in I$ and $n \geq 1$ an operator $T_n(i) \in \mathcal{L}(X, Y)$ be given, and assume that*

$$T(i) := \sum_{n \geq 1} T_n(i)$$

converges in the weak operator topology of $\mathcal{L}(X, Y)$ for all $i \in I$. If each of the families $\mathcal{T}_n := \{T_n(i) : i \in I\}$ is R -bounded and if $\sum_{n \geq 1} \mathcal{R}(\mathcal{T}_n) < \infty$, then $\mathcal{T} := \{T(i) : i \in I\}$ is R -bounded, and for all $1 \leq p < \infty$ we have

$$\mathcal{R}_p(\mathcal{T}) \leq \sum_{n \geq 1} \mathcal{R}_p(\mathcal{T}_n).$$

Proof. Put $S_k(i) = \sum_{j=1}^k T_j(i)$. For all $x_1, \dots, x_N \in X$ and $i_1, \dots, i_N \in I$ we have

$$\begin{aligned} \left\| \sum_{n=1}^N \varepsilon_n S_k(i_n) x_n \right\|_{L^p(\Omega; Y)} &\leq \sum_{j=1}^k \left\| \sum_{n=1}^N \varepsilon_n T_j(i_n) x_n \right\|_{L^p(\Omega; Y)} \\ &\leq \sum_{j=1}^k \mathcal{R}_p(\mathcal{T}_j) \left\| \sum_{n=1}^N \varepsilon_n x_n \right\|_{L^p(\Omega; X)}. \end{aligned}$$

In view of the fact that $T(i) = \lim_{k \rightarrow \infty} S_k(i)$ in the weak operator topology and $\sum_{n \geq 1} \mathcal{R}_p(\mathcal{T}_n) \leq \kappa_{p,2} \sum_{n \geq 1} \mathcal{R}(\mathcal{T}_n) < \infty$, the proof is finished by an appeal to Proposition 8.1.22. \square

8.2 Sources of R -boundedness in real analysis

We interrupt our development of Banach space-valued analysis to discuss the various appearances of R -boundedness in the context of classical real analysis on the (scalar-valued) L^p -spaces. This setting offers a number of specific techniques for proving R -boundedness that are not available in the full generality of Banach spaces.

8.2.a Pointwise domination by the maximal operator

In Proposition 8.1.10 we already saw that operators pointwise dominated by a fixed bounded *linear* operator will be R -bounded L^p -spaces. On Euclidean domains the role of the dominating operator can also be assumed by the Hardy–Littlewood maximal operator

$$Mf(x) := \sup_{Q \ni x} \frac{1}{|Q|} \int_Q |f| \, dy,$$

where the supremum is over all axes-parallel cubes $Q \subseteq \mathbb{R}^d$ containing x .

Proposition 8.2.1 (Domination by the maximal operator). For all $1 < p < \infty$ the family

$$\mathcal{T}_M := \{T \in \mathcal{L}(L^p(\mathbb{R}^d)) : |Tf| \leq M|f| \text{ for all } f \in L^p(\mathbb{R}^d)\}$$

is R -bounded, and $\mathcal{R}_p(\mathcal{T}_M) \leq c_{p,d}$.

Proof. We have

$$\begin{aligned} \left\| \left(\sum_{n=1}^N |T_n f_n|^2 \right)^{1/2} \right\|_{L^p(\mathbb{R}^d)} &\leq \left\| \left(\sum_{n=1}^N (M f_n)^2 \right)^{1/2} \right\|_{L^p(\mathbb{R}^d)} \\ &\leq c_{p,d} \left\| \left(\sum_{n=1}^N |f_n|^2 \right)^{1/2} \right\|_{L^p(\mathbb{R}^d)}, \end{aligned}$$

where the last estimate is a direct application of the Fefferman–Stein maximal inequality (Theorem 3.2.28). This proves the ℓ^2 -boundedness of \mathcal{T}_M , and therewith its R -boundedness. \square

Remark 8.2.2. Using the full scope of the Fefferman–Stein inequality

$$\left\| \left(\sum_{n=1}^N |M f_n|^q \right)^{1/q} \right\|_{L^p(\mathbb{R}^d)} \leq c_{p,q,d} \left\| \left(\sum_{n=1}^N |f_n|^q \right)^{1/q} \right\|_{L^p(\mathbb{R}^d)}, \quad 1 < p, q < \infty,$$

the same proof also shows that \mathcal{T}_M has the property of ℓ^q -boundedness, which may be defined for Banach lattices X, Y by the inequality

$$\left\| \left(\sum_{n=1}^N |T_n f_n|^q \right)^{1/q} \right\|_Y \leq C \left\| \left(\sum_{n=1}^N |f_n|^q \right)^{1/q} \right\|_X, \quad (8.1)$$

over the usual quantifiers. It is important here that, when choosing the operators $(T_n)_{n=1}^N$, repetitions are allowed.

Here is a model application of Proposition 8.2.1:

Proposition 8.2.3. Let \mathcal{K} consist of all $k \in L^1(\mathbb{R}^d)$ such that

$$\int_{\mathbb{R}^d} \operatorname{ess\,sup}_{|y| \geq |x|} |k(y)| \, dx \leq 1.$$

Then the family of convolution operators $\mathcal{T}_{\mathcal{K}} := \{f \mapsto k * f : k \in \mathcal{K}\}$ is R -bounded on $L^p(\mathbb{R}^d)$ for all $p \in (1, \infty)$, and $\mathcal{R}_p(\mathcal{T}_{\mathcal{K}}) \leq c_{p,d}$.

Proof. By Proposition 2.3.9, for each $k \in \mathcal{K}$ and $f \in L^p(\mathbb{R}^d)$, $|k * f(x)| \leq Mf(x)$ for $x \in \mathbb{R}^d$. Therefore, the result follows from Proposition 8.2.1. \square

Corollary 8.2.4. *Let \mathcal{K} consist of kernels $k \in L^1(\mathbb{R}^d)$ that are radially decreasing, i.e., $|k(y)| \leq |k(x)|$ for all $x, y \in \mathbb{R}^d$ with $|y| \geq |x|$, and*

$$\int_{\mathbb{R}^d} |k(x)| \, dx \leq 1.$$

*Then the family of convolution operators $\mathcal{T}_{\mathcal{K}} := \{f \mapsto k * f : k \in \mathcal{K}\}$ is R -bounded on $L^p(\mathbb{R}^d)$ for all $p \in (1, \infty)$, and $\mathcal{R}_p(\mathcal{T}_{\mathcal{K}}) \leq c_{p,d}$.*

Example 8.2.5 (R-analyticity of the heat semigroup). Consider the heat semigroup $(H(z))_{z \in |\arg(z)| < \pi/2}$ on $L^p(\mathbb{R}^d)$ (see Example G.5.6) given by convolution with the heat kernel,

$$H(z)f = k_z * f, \quad |\arg(z)| < \pi/2,$$

where the kernels $k_z : \mathbb{R}^d \rightarrow \mathbb{C}$ given by

$$k_z(x) = \frac{1}{\sqrt{(2\pi z)^d}} \exp(-|x|^2/(2z)), \quad x \in \mathbb{R}^d.$$

The family $\{k_t : t > 0\}$ clearly satisfies the conditions of Corollary 8.2.4. We claim that for all $\theta < \frac{1}{2}\pi$ the family $\{k_z : |\arg(z)| \leq \theta\}$ still satisfies the condition of Proposition 8.2.3 up to a multiplicative constant. As a result the family $(H(z))_{|\arg(z)| \leq \theta}$ is R -bounded on $L^p(\mathbb{R}^d)$ for all $p \in (1, \infty)$.

To prove the claim, fix $z \in \mathbb{C}$ with $|\arg(z)| \leq \theta$ and put $t := \Re z$. With $c(z) := \cos(\arg z)$ we have $|z| = t/c(z)$ and $\Re(1/z) = \Re \bar{z}/|z|^2 = t^{-1}c^2(z)$, and therefore

$$\begin{aligned} \left| \frac{1}{\sqrt{(2\pi z)^d}} \exp(-|x|^2/(2z)) \right| &= \frac{1}{\sqrt{(2\pi t^d/c^d(z))}} \exp(-|x|^2 c^2(z)/2t) \\ &= c^{-d/2}(z) k_{t/c^2(z)}(x). \end{aligned}$$

The kernel on the right-hand side is positive and satisfies $|k_t(y)| \geq |k_t(x)|$ if $|y| \leq |x|$, and

$$\int_{\mathbb{R}^d} c^{-d/2}(z) k_{t/c^2(z)}(x) \, dx \leq \frac{1}{\cos^{d/2} \theta}.$$

It follows that the condition of Proposition 8.2.3 is satisfied, with constant $1/\cos^{d/2} \theta$ instead of 1.

8.2.b Inequalities with Muckenhoupt weights

Many common operators of real and harmonic analysis are known to be bounded on the weighted spaces $L^p(w) := L^p(\mathbb{R}^d, w)$, when w is a weight in the Muckenhoupt class A_p . We refer the reader to Appendix J for a brief introduction to these classes. In particular we recall that, by definition, a weight $w \in L^1_{\text{loc}}(\mathbb{R}^d)$ belongs to the Muckenhoupt A_p class if $w(x) > 0$ for almost all $x \in \mathbb{R}^d$ and

$$[w]_{A_p} := \sup_Q \left(\int_Q w(x) \, dx \right) \left(\int_Q w^{1-p'}(x) \, dx \right)^{p-1} < \infty;$$

the supremum is taken over all (axes-parallel) cubes $Q \subseteq \mathbb{R}^d$. The Notes at the end of the chapter provide a sample of the many $L^p(w)$ -boundedness theorems for various classical operators. Such *weighted bounds* provide a powerful tool for deducing R -boundedness (or, what is equivalent in this setting, ℓ^2 -boundedness) of operators on $L^p(\mathbb{R}^d)$. In fact, without additional effort, more generally we also get ℓ^q -boundedness (see (8.1)), which is useful in various applications.

Theorem 8.2.6. *Let $r \in (1, \infty)$ and let $\phi_r : [1, \infty) \rightarrow [0, \infty)$ be a non-decreasing function. Let \mathcal{T} be a class of (not necessarily linear or even sub-linear) operators simultaneously acting in $L^r(w)$ for every $w \in A_r$ and such that the inequality*

$$\|Tf\|_{L^r(w)} \leq \phi_r([w]_{A_r}) \|f\|_{L^r(w)}$$

holds for all $T \in \mathcal{T}$, $w \in A_r$ and $f \in L^r(w)$. Then for all $p \in (1, \infty)$ and $w \in A_p$, every $T \in \mathcal{T}$ is defined and bounded on $L^p(w)$, and the family \mathcal{T} is ℓ^q -bounded on $L^p(w)$ for all $q \in (1, \infty)$. Moreover, there exists a non-decreasing function $\phi_{pqr} : [1, \infty) \rightarrow [0, \infty)$ such that

$$\left\| \left(\sum_{n=1}^N |T_n f_n|^q \right)^{1/q} \right\|_{L^p(w)} \leq \phi_{pqr}([w]_{A_p}) \left\| \left(\sum_{n=1}^N |f_n|^q \right)^{1/q} \right\|_{L^p(w)}$$

for all $f_n \in L^p(w)$ and $T_n \in \mathcal{T}$.

Proof. That the action of $T \in \mathcal{T}$ is automatically defined on $f \in L^p(w)$ for $w \in A_p$ is immediate from Corollary J.2.6, which guarantees that such an f also belongs to $L^r(W)$ for some $W \in A_r$, and on this space the action of T is defined by assumption.

Let us consider the pair of functions

$$(f, g) := \left(\left(\sum_{n=1}^N |f_n|^r \right)^{1/r}, \left(\sum_{n=1}^N |T_n f_n|^r \right)^{1/r} \right).$$

It is immediate from the assumption that

$$\|g\|_{L^r(w)} \leq \phi_r([w]_{A_r}) \|f\|_{L^r(w)} \quad \text{for all } w \in A_r.$$

Thus, Rubio de Francia's extrapolation theorem (Theorem J.2.1) guarantees that

$$\|g\|_{L^p(w)} \leq \phi_{pr}([w]_{A_p}) \|f\|_{L^p(w)} \quad \text{for all } p \in (1, \infty) \text{ and } w \in A_p,$$

which is the claimed conclusion in the special case that $q = r$. Specialising further to $N = 1$, and writing q instead of p we find that we obtain an

estimate similar to the assumption but with arbitrary $q \in (1, \infty)$ in place of r . Repeating the same argument starting from this q , we obtain the claimed conclusion for all $p, q \in (1, \infty)$. \square

Remark 8.2.7. By Muckenhoupt's classical Theorem J.1.1, the Hardy–Littlewood maximal operator M , and hence also the class \mathcal{T}_M defined in Proposition 8.2.1, satisfies the assumption, and therefore the conclusion, of Theorem 8.2.6. Thus Proposition 8.2.1 and its corollaries in the previous subsection can also be viewed as corollaries of Theorem 8.2.6.

8.2.c Characterisation by weighted inequalities in L^p

In the next two propositions we characterise ℓ^r -boundedness (see (8.1)) in terms of weighted boundedness of a family of operators $\mathcal{T} \subseteq \mathcal{L}(L^p, L^q)$. The proof works for non-linear operators and we will consider this setting below. For $r = 2$ the results imply a characterisation of R -boundedness of families of operators acting between L^p and L^q (see Theorem 8.2.11).

Proposition 8.2.8. *Let $(S_1, \mathcal{A}_1, \mu_1)$ and $(S_2, \mathcal{A}_2, \mu_2)$ be σ -finite measure spaces and let $0 < r < p, q < \infty$. Let \mathcal{T} be a family of (possibly non-linear) mappings from $L^p(\mu_1)$ into $L^q(\mu_2)$ such that $T(\lambda f) = \lambda T(f)$ for all $f \in L^p(\mu_1)$ and $\lambda \geq 0$. For any constant $C \geq 0$ the following assertions are equivalent:*

(1) *for all finite sequences $(T_n)_{n=1}^N$ in \mathcal{T} and all $(f_n)_{n=1}^N$ in $L^p(\mu_1)$ we have*

$$\left\| \left(\sum_{n=1}^N |T_n f_n|^r \right)^{1/r} \right\|_{L^q(\mu_2)} \leq C \left\| \left(\sum_{n=1}^N |f_n|^r \right)^{1/r} \right\|_{L^p(\mu_1)};$$

(2) *for all non-negative $w_2 \in L^{q/(q-r)}(\mu_2)$ there exists a non-negative weight $w_1 \in L^{p/(p-r)}(\mu_1)$ satisfying $\|w_1\|_{L^{p/(p-r)}(\mu_1)} \leq \|w_2\|_{L^{q/(q-r)}(\mu_2)}$ such that*

$$\|Tf\|_{L^r(w_2\mu_2)} \leq C \|f\|_{L^r(w_1\mu_1)}, \quad T \in \mathcal{T}, f \in L^p(\mu_1). \quad (8.2)$$

Note that by Hölder's inequality we have continuous inclusions $L^p(\mu_1) \subseteq L^r(w_1\mu_1)$ and $L^q(\mu_2) \subseteq L^r(w_2\mu_2)$.

A corresponding result for $0 < p, q < r < \infty$ is stated in Proposition 8.2.10.

One of the main ingredients in the proof of Proposition 8.2.8 is a mini-max lemma from real analysis (see the Notes for more information).

Lemma 8.2.9 (Mini-max Lemma). *Let A and B be convex subsets of a vector space V and a Hausdorff topological vector space W , respectively, and assume that B is compact. Let $\Phi : A \times B \rightarrow \mathbb{R} \cup \{+\infty\}$ be a function with the following properties:*

(i) *for all $b \in B$, $\Phi(\cdot, b)$ is concave;*

(ii) for all $a \in A$, $\Phi(a, \cdot)$ is convex and lower semi-continuous.

Then

$$\min_{b \in B} \sup_{a \in A} \Phi(a, b) = \sup_{a \in A} \min_{b \in B} \Phi(a, b) \leq 0.$$

Proof of Proposition 8.2.8. (2) \Rightarrow (1): Let $f_1, \dots, f_n \in L^p(\mu_1)$. By the Hahn-Banach theorem we can find $w_2 \in (L^{q/r}(\mu_2))^* = L^{\frac{q}{q-r}}(\mu_2)$ of norm one with $w_2 \geq 0$ such that

$$\left(\int_{S_2} \left(\sum_{n=1}^N |T_n f_n|^r \right)^{q/r} d\mu_2 \right)^{r/q} = \int_{S_2} \sum_{n=1}^N |T_n f_n|^r w_2 d\mu_2.$$

Now let w_1 be as in assertion (2) of the proposition. By the assumption,

$$\begin{aligned} & \left(\int_{S_2} \left(\sum_{n=1}^N |T_n f_n|^r \right)^{q/r} d\mu_2 \right)^{r/q} = \sum_{n=1}^N \int_{S_2} |T_n f_n|^r w_2 d\mu_2 \\ & \leq C^r \sum_{n=1}^N \int_{S_1} |f_n|^r w_1 d\mu_1 = C^r \int_{S_1} \sum_{n=1}^N |f_n|^r w_1 d\mu_1 \\ & \leq C^r \left(\int_{S_1} \left(\sum_{n=1}^N |f_n|^r \right)^{p/r} d\mu_1 \right)^{r/p}, \end{aligned}$$

where we used Hölder's inequality with $\frac{r}{p} + \frac{p-r}{p} = 1$ and $\|w_1\|_{L^{p/(p-r)}(\mu_1)} \leq \|w_2\|_{L^{q/(q-r)}(\mu_2)} = 1$. This proves (1).

(1) \Rightarrow (2): It suffices to consider $w_2 \in L^{q/(q-r)}(\mu_2)$ with $w_2 \geq 0$ and $\|w_2\|_{L^{q/(q-r)}(\mu_2)} = 1$. Let $A \subseteq L^{p/r}(\mu_1) \times L^{q/r}(\mu_2)$ be the set of pairs (a_1, a_2) such that

$$a_1 = \sum_{n=1}^N |f_n|^r, \quad a_2 = \sum_{n=1}^N |T_n f_n|^r,$$

with $T_n \in \mathcal{T}$ and $f_n \in L^p(\mu_1)$ for $1 \leq n \leq N$, where N may vary as well. Then A is a convex set. Indeed, let (a_1, a_2) and (b_1, b_2) in A and let $\lambda \in (0, 1)$. We can write $a_1 = \sum_{n=1}^N |f_n|^r$ and $b_1 = \sum_{n=N+1}^M |f_n|^r$ and $a_2 = \sum_{n=1}^N |T_n f_n|^r$ and $b_2 = \sum_{n=N+1}^M |T_n f_n|^r$ with $f_n \in L^p(\mu_1)$ for all $1 \leq n \leq N$. Let $g_n = \lambda^{1/r} f_n$ for $1 \leq n \leq N$ and $g_n = (1-\lambda)^{1/r} f_n$ for $N+1 \leq n \leq M$. Clearly, we have

$$\lambda a_1 + (1-\lambda)b_1 = \sum_{n=1}^N |g_n|^r \quad \text{and} \quad \lambda a_2 + (1-\lambda)b_2 = \sum_{n=1}^M |T_n g_n|^r.$$

and thus $\lambda(a_1, a_2) + (1-\lambda)(b_1, b_2)$ is in A . Consider the following convex and weakly compact set B of $L^{p/(p-r)}(\mu_1)$:

$$B = \{b \in L^{p/(p-r)}(\mu_1) : b \geq 0, \|b\|_{L^{p/(p-r)}(\mu_1)} \leq 1\}.$$

Let $\Phi : A \times B \rightarrow (-\infty, \infty]$ be given by

$$\Phi(a, b) = \int_{S_2} a_2 w_2 \, d\mu_2 - C^r \int_{S_1} a_1 b \, d\mu_1, \quad a = (a_1, a_2).$$

For fixed $b \in B$, $\Phi(\cdot, b)$ is affine-linear and hence concave. Similarly, for each $a \in A$, $\Phi(a, \cdot)$ is linear and hence convex. Clearly, $\Phi(a, \cdot)$ is weakly continuous.

By the assumption and Hölder's inequality one sees that for all $a \in A$,

$$\begin{aligned} \min_{b \in B} \Phi(a, b) &= \min_{b \in B} \left[\int_{S_2} \sum_{n=1}^N |Tf_n|^r w_2 \, d\mu_2 - C^r \int_{S_1} \sum_{n=1}^N |f_n|^r b \, d\mu_1 \right] \\ &\leq \left\| \sum_{n=1}^N |Tf_n|^r \right\|_{L^{q/r}(\mu_2)} - C^r \left\| \sum_{n=1}^N |f_n|^r \right\|_{L^{p/r}(\mu_1)} \leq 0. \end{aligned}$$

It follows from the mini-max Lemma 8.2.9 that

$$\min_{b \in B} \sup_{a \in A} \Phi(a, b) = \sup_{a \in A} \min_{b \in B} \Phi(a, b) \leq 0.$$

Hence can find a $w_1 \in B$ such that for all $a \in A$ one has $\Phi(a, w_1) \leq 0$. In particular, considering $a = (|f|^r, |Tf|^r)$ with $f \in L^p(\mu_1)$, we obtain (8.2). \square

The following version of Proposition 8.2.8 holds for $p, q < r$.

Proposition 8.2.10. *Let $(S_1, \mathcal{A}_1, \mu_1)$ and $(S_2, \mathcal{A}_2, \mu_2)$ be σ -finite measure spaces and let $0 < p, q < r < \infty$. Let \mathcal{T} be a family of (possibly non-linear) mappings from $L^p(\mu_1)$ into $L^q(\mu_2)$ such that $T(\lambda f) = \lambda T(f)$ for all $f \in L^p(\mu_1)$ and $\lambda \geq 0$. For any constant $C \geq 0$ the following assertions are equivalent:*

(1) *for all finite sequences $(T_n)_{n=1}^N$ in \mathcal{T} and all $(f_n)_{n=1}^N$ in $L^p(\mu_1)$ we have*

$$\left\| \left(\sum_{n=1}^N |T_n f_n|^r \right)^{1/r} \right\|_{L^q(\mu_2)} \leq C \left\| \left(\sum_{n=1}^N |f_n|^r \right)^{1/r} \right\|_{L^p(\mu_1)};$$

(2) *for all non-negative $w_1 \in L^{p/(r-p)}(\mu_1)$ there exists a non-negative weight $w_2 \in L^{q/(r-q)}(\mu_2)$ satisfying $\|w_2\|_{L^{q/(r-q)}(\mu_2)} \leq \|w_1\|_{L^{p/(r-p)}(\mu_1)}$ such that*

$$\|Tf\|_{L^r(w_2^{-1}\mu_2)} \leq C \|f\|_{L^r(w_1^{-1}\mu_1)}, \quad T \in \mathcal{T}, \quad f \in L^r(w_1^{-1}\mu_1). \quad (8.3)$$

In the above result it is understood that $w_i(s)^{-1} = 0$ if $w_i(s) = 0$, $i = 1, 2$. Note that by Hölder's inequality we have continuous inclusions $L^r(w_1^{-1}\mu_1) \subseteq L^p(\mu_1)$ and $L^r(w_2^{-1}\mu_2) \subseteq L^q(\mu_2)$.

Proof. Note that for every function $f \in L^p(\mu_i)$ with $\rho \in (0, 1)$ we have

$$\|f\|_{L^\rho(\mu_i)} = \inf_{v \in V_\rho} \int_{S_i} |f|v^{-1} \, d\mu_i, \quad (8.4)$$

where $V_\rho = \{v \geq 0 \text{ and } \|v\|_{L^{\rho/(1-\rho)}(\mu_i)} \leq 1\}$ and the infimum is attained. Indeed, the inequality ' \leq ' of (8.4) follows from Hölder's inequality, while ' \geq ' follows by taking $v = |f|^{1-\rho}/\|f\|_{L^\rho(\mu_1)}^{1-\rho}$

(2) \Rightarrow (1): Let $f_1, \dots, f_N \in L^p(\mu_1)$ and set $f := (\sum_{n=1}^N |f_n|^r)^{1/r}$. By (8.4) (applied, with $\rho = p/r$, to the function $f^r = \sum_{n=1}^N |f_n|^r$), there exists a weight $w_1 \in V_{p/r}$ of norm one such that

$$\|f^r\|_{L^{p/r}(\mu_1)} = \int_{S_1} |f|^r w_1^{-1} d\mu_1.$$

Let w_2 be as in (2). Then $\|w_2\|_{L^{q/(r-q)}(\mu_2)} \leq 1$ and it follows from (8.4) (applied, with $\rho = q/r$, to the function $\sum_{n=1}^N |T_n f_n|^r$), and the assumption in (2) that

$$\begin{aligned} \left(\int_{S_2} \left(\sum_{n=1}^N |T_n f_n|^r \right)^{q/r} d\mu_2 \right)^{r/q} &\leq \int_{S_2} \sum_{n=1}^N |T_n f_n|^r w_2^{-1} d\mu_2 \\ &\leq C^r \int_{S_1} \sum_{n=1}^N |f_n|^r w_1^{-1} d\mu_1 \\ &= C^r \left(\int_{S_1} \left(\sum_{n=1}^N |f_n|^r \right)^{p/r} d\mu_1 \right)^{r/p}. \end{aligned}$$

(1) \Rightarrow (2): It suffices to consider $w_1 \in L^{p/(r-p)}(\mu_1)$ with $w_1 \geq 0$ and $\|w_1\|_{L^{p/(r-p)}(\mu_1)} = 1$.

Let $A \subseteq L^1(w_1^{-1}\mu_1) \times L^{q/r}(\mu_2)$ be the set of pairs (a_1, a_2) such that

$$a_1 = \sum_{n=1}^N |f_n|^r, \quad a_2 = \sum_{n=1}^N |T_n f_n|^r$$

with $T_n \in \mathcal{T}$ and $f_n \in L^r(w_1^{-1}\mu_1) \subseteq L^p(\mu_1)$ for $1 \leq n \leq N$, where N may vary as well. Then as in the proof of Proposition 8.2.8 we see that A is a convex set. Consider the following convex and weakly compact set B :

$$B = \{b \in L^{r/(r-q)}(\mu_2) : b \geq 0, \|b\|_{L^{r/(r-q)}(\mu_2)} \leq 1\}.$$

Let $\Phi : A \times B \rightarrow (-\infty, \infty]$ be given by

$$\Phi(a, b) = \int_{S_2} a_2 b^{-q/r} d\mu_2 - C^r \int_{S_1} a_1 w_1^{-1} d\mu_1, \quad a = (a_1, a_2).$$

For fixed $b \in B$, $\Phi(\cdot, b)$ is linear and hence concave. On the other hand, since $x \mapsto x^{-q/r}$ is convex, $\Phi(a, \cdot)$ is convex for each $a \in A$.

We claim that $\Phi(a, \cdot)$ is weakly lower semi-continuous. Indeed, let $r \in [0, \infty)$. It suffices to show that $B_r = \{b \in B : \Phi(a, b) \leq r\}$ is weakly

closed. Since B_r is convex (by the convexity of $x \mapsto x^{-q/r}$), it suffices to show that B_r is closed. Choose $(b_n)_{n \geq 1}$ in B_r such that $\lim_{n \rightarrow \infty} b_n = b$ exists in $L^{r/r-q}(\mu_2)$. We can find a subsequence such that $\lim_{k \rightarrow \infty} b_{n_k} = b$ almost everywhere, hence $b \geq 0$, and it follows from Fatou's lemma that $\Phi(a, b) \leq \liminf_{k \rightarrow \infty} \Phi(a, b_{n_k}) \leq r$. Thus B_r is closed and the claim follows.

By the assumption, (8.4) (noting that $b \in B$ implies $b^{q/r} \in V_{q/r}$), and Hölder's inequality one sees that for all $a \in A$,

$$\begin{aligned} \min_{b \in B} \Phi(a, b) &= \min_{b \in B} \left[\int_{S_2} \sum_{n=1}^N |Tf_n|^r b^{-q/r} d\mu_2 - C^r \int_{S_1} \sum_{n=1}^N |f_n|^r w_1^{-1} d\mu_1 \right] \\ &\leq \left\| \sum_{n=1}^N |Tf_n|^r \right\|_{L^{q/r}(\mu_2)} - C^r \left\| \sum_{n=1}^N |f_n|^r \right\|_{L^{p/r}(\mu_1)} \leq 0. \end{aligned}$$

It follows from the mini-max Lemma 8.2.9 that

$$\min_{b \in B} \sup_{a \in A} \Phi(a, b) = \sup_{a \in A} \min_{b \in B} \Phi(a, b) \leq 0.$$

Hence there exists a $b \in B$ such that $\Phi(a, b) \leq 0$ for all $a \in A$. In particular, considering $a = (|f|^r, |Tf|^r)$ with $f \in L^r(w_1^{-1}\mu_1)$, we obtain (8.3) with $w_2 := b^{q/r}$. \square

Propositions 8.2.8 and 8.2.10 and Remark 8.1.4 immediately give the following characterisation of R -boundedness of families of operators from L^p into L^q .

Theorem 8.2.11 (R -boundedness from L^p to L^q via weights). *Let $(S_1, \mathcal{A}_1, \mu_1)$ and $(S_2, \mathcal{A}_2, \mu_2)$ be measure spaces and let $p, q \in (1, \infty)$. Let $\mathcal{T} \subseteq \mathcal{L}(L^p(\mu_1), L^q(\mu_2))$ be a family of linear operators. Then:*

- (1) *if $p, q \in (2, \infty)$, the family \mathcal{T} is R -bounded if and only if there exists a constant $C \geq 0$ such that for every $w_2 \in L^{q/(q-2)}(\mu_2)$ with $w_2 \geq 0$ there exists a $w_1 \in L^{p/(p-2)}(\mu_1)$ with $w_1 \geq 0$ and $\|w_1\|_{L^{p/(p-2)}(\mu_1)} \leq \|w_2\|_{L^{q/(q-2)}(\mu_2)}$ such that*

$$\|Tf\|_{L^2(w_2)} \leq C \|f\|_{L^2(w_1)}, \quad T \in \mathcal{T}, f \in L^2(\mu_1); \quad (8.5)$$

- (2) *if $p, q \in (1, 2)$, the family \mathcal{T} is R -bounded if and only if there exists a constant $C \geq 0$ such that for every weight $w_1 \in L^{p/(2-p)}(\mu_1)$ with $w_1 \geq 0$ there exists a weight $w_2 \in L^{q/(2-q)}(\mu_2)$ with $w_2 \geq 0$ and $\|w_2\|_{L^{q/(2-q)}(\mu_2)} \leq \|w_1\|_{L^{p/(2-p)}(\mu_1)}$ such that*

$$\|Tf\|_{L^2(w_2^{-1})} \leq C \|f\|_{L^2(w_1^{-1})}, \quad T \in \mathcal{T}, f \in L^2(w_1^{-1}\mu_1). \quad (8.6)$$

If C' denotes the least admissible constant in (8.5) or (8.6), then for all $1 \leq r < \infty$ we have

$$(\kappa_{p,2}\kappa_{2,q})^{-1}C' \leq \mathcal{R}_{q,p}(\mathcal{T}) \leq \kappa_{2,p}\kappa_{q,2}C'.$$

8.3 Fourier multipliers and R -boundedness

A *Fourier multiplier* with symbol $m \in L^\infty(\mathbb{R}^d; \mathcal{L}(X, Y))$ is the operator

$$f \mapsto T_m f = (m\widehat{f})^\sim,$$

initially defined on the space $\check{L}^1(\mathbb{R}^d; X) = \{\check{g} : g \in L^1(\mathbb{R}^d; X)\}$ of inverse Fourier transforms of $L^1(\mathbb{R}^d; X)$ -functions, and mapping into $\check{L}^1(\mathbb{R}^d; Y)$. These operators have been studied in Chapter 5, where we addressed the basic question of their L^p -boundedness, i.e., the *a priori* estimate

$$\|T_m f\|_{L^p(\mathbb{R}^d; Y)} \leq C \|f\|_{L^p(\mathbb{R}^d; X)}$$

for all $f \in \check{L}^1(\mathbb{R}^d; X) \cap L^p(\mathbb{R}^d; X)$ or a dense subspace thereof. This estimate, when valid, permits the unique extension of T_m to a bounded linear operator from $L^p(\mathbb{R}^d; X)$ to $L^p(\mathbb{R}^d; Y)$.

This theory has intimate ties with R -boundedness. We already saw a glimpse of this interplay in Chapter 5 where, among other things, the following implications were established (see Theorems 5.3.15 and 5.3.18):

$$\begin{aligned} & \{m(\xi), \xi m'(\xi) : \xi \in \mathbb{R}\} \subseteq \mathcal{L}(X, Y) \text{ is } R\text{-bounded, and } X, Y \text{ have UMD} \\ & \Rightarrow T_m : L^p(\mathbb{R}; X) \rightarrow L^p(\mathbb{R}; Y) \text{ is bounded for } p \in (1, \infty) \\ & \Rightarrow \{m(\xi) : \xi \in \mathbb{R} \text{ Lebesgue-point of } m\} \text{ is } R\text{-bounded.} \end{aligned}$$

With the general theory of R -boundedness at hand, we now return to explore its further connections to Fourier multipliers. We begin with a new proof of the first implication above, which uses R -boundedness in more systematic way, leading not only to an essentially sharper form of the final result but also to a number of intermediate R -boundedness estimates of independent interest.

8.3.a Multipliers of bounded variation on the line

The following R -boundedness result is fairly immediate. We denote by

$$\Delta_E := T_{\mathbf{1}_E} \tag{8.7}$$

the Fourier multiplier whose symbol is the indicator function of the set E .

Proposition 8.3.1. *Let X be a UMD space and $p \in (1, \infty)$. Let \mathcal{J} be the collection of all intervals $J \subseteq \mathbb{R}$. Then*

$$\Delta_{\mathcal{J}} := \{\Delta_J : J \in \mathcal{J}\}$$

is R -bounded on $L^p(\mathbb{R}; X)$, and more precisely

$$\mathcal{R}_p\{\Delta_J : J \in \mathcal{J}\} \leq \mathfrak{h}_{p, X} := \|H\|_{\mathcal{L}(L^p(\mathbb{R}; X))},$$

where H denotes the Hilbert transform.

Proof. By Lemma 5.3.9 (or a direct verification by comparison of the corresponding multipliers), when J is a finite interval, we have the representation

$$\Delta_J = \frac{i}{2} \left(M_{a_J} H M_{-a_J} - M_{b_J} H M_{-b_J} \right),$$

where each M_a is the modulation operator $M_a : f \mapsto e_a f$ (where $e_a(t) := \exp(2\pi i a t)$), and a_J and b_J are the left and right end-points of the interval J . By Example 8.1.9, we have $\mathcal{R}_p(\{M_a : a \in \mathbb{R}\}) = 1$ on $L^p(\mathbb{R}; X)$, and by Example 8.1.7 the singleton $\{H\}$ has R -bound $\tilde{h}_{p,X}$ on $L^p(\mathbb{R}; X)$. So a version of the claim, where the R -bound is over all finite intervals, follows from the sum and product rules of R -bounds. The general case follows since $\Delta_{(a,\infty)} f = \lim_{n \rightarrow \infty} \Delta_{(a,n)} f$ and a similar result for $\Delta_{(-\infty,b)}$, by the stability of R -boundedness under strong operator closure (Proposition 8.1.22). \square

Definition 8.3.2. Let $S \subseteq \mathbb{R}$ and X be a normed space. A function $f : S \rightarrow X$ is said to have bounded variation if

$$\|f\|_{\dot{V}^1(S;X)} := \sup_{K \geq 0} \sup_{\substack{t_0, t_1, \dots, t_K \in S \\ t_0 < t_1 < \dots < t_K}} \sum_{k=1}^K \|f(t_{k-1}) - f(t_k)\| < \infty.$$

For such functions we define

$$\|f\|_{V^1(S;X)} := \|f\|_{\dot{V}^1(S;X)} + \sup_{t \in S} \|f(t)\|.$$

Lemma 8.3.3. Let $I \subseteq \mathbb{R}$ be an interval and X a normed space. If $f : I \rightarrow X$ has bounded variation, then f has at most countably many points of discontinuity.

Proof. Let us write

$$Jf(t) := \limsup_{s \rightarrow t} \|f(s) - f(t)\|.$$

Then f is discontinuous at t if and only if $Jf(t) > 0$. Let $\varepsilon > 0$ and suppose that there are K points $x_0 < x_1 < \dots < x_{K-1}$ where $Jf(x_k) > \varepsilon$. Let $\delta := \min_{1 \leq k < K} |x_{k-1} - x_k|$. By definition of Jf , we can find points $y_k \in B(x_k, \delta/2) \setminus \{x_k\}$ such that $\|f(x_k) - f(y_k)\| > \varepsilon$. Denoting $t_{2k} := \min\{x_k, y_k\}$, $t_{2k+1} := \max\{x_k, y_k\}$, it then follows that $(t_k)_{k=1}^{2K}$ is an increasing sequence, and

$$\begin{aligned} K\varepsilon &< \sum_{k=0}^{K-1} \|f(x_k) - f(y_k)\| = \sum_{k=0}^{K-1} \|f(t_{2k}) - f(t_{2k+1})\| \\ &\leq \sum_{k=1}^{2K-1} \|f(t_{k-1}) - f(t_k)\| \leq \|f\|_{\dot{V}^1(I;X)}. \end{aligned}$$

This shows that $K < \varepsilon^{-1} \|f\|_{\dot{V}^1(I; X)}$. In particular, for every $n \in \mathbb{Z}_+$, there are only finitely many points x where $Jf(x) > n^{-1}$, and hence only countably many points where $Jf(x) > 0$. This proves the lemma. \square

A bounded absolutely convex set \mathcal{T} of a normed space Z gives rise to the normed space

$$Z_{\mathcal{T}} := \{z \in Z : z \in \lambda \mathcal{T} \text{ for some } \lambda > 0\}$$

where the norm is given by the Minkowski functional

$$\|z\|_{\mathcal{T}} := \inf\{\lambda > 0 : z \in \lambda \mathcal{T}\}.$$

In this situation, we will denote $\dot{V}^1(S; Z_{\mathcal{T}})$ simply by $\dot{V}^1(S; \mathcal{T})$, and similarly for the inhomogeneous version V^1 . We are particularly concerned with the case of an R -bounded set $\mathcal{T} \subseteq \mathcal{L}(X, Y)$.

Theorem 8.3.4. *Let X or Y (sic!) be a UMD space, and $p \in (1, \infty)$. Let $\mathcal{T} \subseteq \mathcal{L}(X, Y)$ be an absolutely convex, R -bounded set. Let $J \subseteq \mathbb{R}$ be an interval. Then every $m \in V^1(J; \mathcal{T})$ gives rise to a bounded operator $T_{m\mathbf{1}_J} \in \mathcal{L}(L^p(\mathbb{R}; X), L^p(\mathbb{R}; Y))$, and moreover, for every $M > 0$,*

$$\mathcal{R}_p(\{T_{m\mathbf{1}_J} : \|m\|_{V^1(J; \mathcal{T})} \leq M, J \in \mathcal{J}\}) \leq M \min\{h_{p, X}, h_{p, Y}\} \mathcal{R}_p(\mathcal{T}).$$

In this inequality it is understood that $h_{p, Z} = \infty$ if the Banach space Z fails UMD.

Proof. Let $J = (a, b)$ and let first $m = m\mathbf{1}_J = m\mathbf{1}_{(a, b)} \in V^1(J; \mathcal{T})$ be a step function,

$$m\mathbf{1}_J = \sum_{k=0}^K \alpha_k \mathbf{1}_{I_k},$$

where $I_0 = (a, a_0)$, $I_k = [a_{k-1}, a_k)$ for $k = 1, \dots, K$, and $I_K = [a_{K-1}, b)$ for some $-\infty \leq a < a_0 < a_1 < \dots < a_{K-1} < b \leq \infty$. Denoting $\delta_j := \alpha_j - \alpha_{j-1}$ for $j \geq 1$, we can rearrange

$$\begin{aligned} m\mathbf{1}_J &= \sum_{k=0}^K \left(\alpha_0 + \sum_{j=1}^k \delta_j \right) \mathbf{1}_{I_k} = \alpha_0 \mathbf{1}_J + \sum_{j=1}^K \delta_j \sum_{k=j}^K \mathbf{1}_{I_k} \\ &= \alpha_0 \mathbf{1}_J + \sum_{j=1}^K \delta_j \mathbf{1}_{[a_{j-1}, b)}, \end{aligned}$$

to see that

$$T_{m\mathbf{1}_J - \alpha_0 \mathbf{1}_J} = \sum_{j=1}^K \delta_j \Delta_{[a_{j-1}, b)} = \sum_{j=1}^K \|\delta_j\|_{\mathcal{T}} \frac{\delta_j}{\|\delta_j\|_{\mathcal{T}}} \Delta_{[a_{j-1}, b)},$$

where $\|\alpha_0\|_{\mathcal{T}} \leq \|m\|_{L^\infty(J; \mathcal{T})}$ and $\sum_{j=1}^K \|\delta_j\|_{\mathcal{T}} \leq \|m\|_{\dot{V}^1(J; \mathcal{T})}$. Thus by Propositions 8.1.21, 8.1.19 and 8.3.1,

$$T_{m\mathbf{1}_J} \in M \operatorname{conv}(\mathcal{T} \Delta_{\mathcal{J}}) =: \widetilde{\mathcal{T}},$$

and

$$\mathcal{R}_p(\widetilde{\mathcal{T}}) \leq M \min\{h_{p,X}, h_{p,Y}\} \mathcal{R}_p(\mathcal{T}) =: \widetilde{M},$$

where the minimum comes from the fact that all $T \in \mathcal{T}$ and $\Delta_I \in \Delta_{\mathcal{J}}$ commute, so that one can use the R -boundedness of $\Delta_{\mathcal{J}}$ on either $L^p(\mathbb{R}; X)$ or $L^p(\mathbb{R}; Y)$, and take the smaller of the resulting bounds.

For a general m in the set under consideration, we first consider approximating step functions $m^{(k)}$, where (say) $m^{(k)}$ takes the constant value $m(\inf I)$ on all dyadic intervals I of length 2^{-k} contained in $[-2^k, 2^k] \cap J$, and the constant extension of this function in $J \setminus [-2^k, 2^k]$. Then $m^{(k)}(\xi) \rightarrow m(\xi)$ at all points of continuity of m , which is at almost every $\xi \in J$ by Lemma 8.3.3. For $f \in \check{L}^1(\mathbb{R}; X)$, it follows from dominated convergence that

$$T_{m\mathbf{1}_J} f(x) = \int_J m(\xi) \widehat{f}(\xi) e^{i2\pi\xi x} d\xi = \lim_{k \rightarrow \infty} T_{m^{(k)}\mathbf{1}_J} f(x),$$

where the multipliers $m^{(k)}$ have the form considered in the first part of the proof.

We apply this observation to N functions $f_n \in L^p(\mathbb{R}; X) \cap \check{L}^1(\mathbb{R}; X)$, multipliers m_n and intervals J_n , and use Fatou's lemma to deduce that

$$\begin{aligned} \left\| \sum_{n=1}^N \varepsilon_n T_{m_n \mathbf{1}_{J_n}} f_n \right\|_{L^p(\mathbb{R} \times \Omega; Y)} &\leq \liminf_{k \rightarrow \infty} \left\| \sum_{n=1}^N \varepsilon_n T_{m_n^{(k)} \mathbf{1}_{J_n}} f_n \right\|_{L^p(\mathbb{R} \times \Omega; Y)} \\ &\leq \widetilde{M} \left\| \sum_{n=1}^N \varepsilon_n f_n \right\|_{L^p(\mathbb{R} \times \Omega; X)}, \end{aligned}$$

by the case of step functions already considered. By density, this proves in particular the boundedness of each $T_{m\mathbf{1}_J}$, and then also the R -boundedness of the full collection, as stated. \square

Example 8.3.5 (R -analyticity of the Poisson semigroup). The Poisson semigroup $(P_t)_{t>0}$ on $L^p(\mathbb{R}; X)$ can be defined as the Fourier multiplier corresponding to the symbol $m_t(\xi) = e^{-2\pi t|\xi|}$. In this formalism it admits a natural extension $(P_z)_{|\arg z| < \pi/2}$, simply by replacing t by z in the formula for the multiplier. With Theorem 8.3.4, it is not difficult to check that $(P_z)_{|\arg z| \leq \theta}$ is R -bounded on $L^p(\mathbb{R}; X)$ when $p \in (1, \infty)$, X is a UMD space, and $\theta < \pi/2$.

Indeed, writing $z = u + iv$, we clearly have $|m_z(\xi)| = e^{-2\pi u|\xi|} \leq 1$, and

$$\|m_z\|_{\dot{V}^1(\mathbb{R}; \mathbb{C})} \leq \int_{\mathbb{R}} |m'_z(\xi)| d\xi = \int_{\mathbb{R}} 2\pi |z| e^{-2\pi u|\xi|} d\xi = 2 \frac{|z|}{u} \leq \frac{2}{\cos \theta}.$$

Thus

$$\mathcal{R}_p(\{P_z\}_{|\arg z| \leq \theta}) \leq \tilde{h}_{p,X} \sup_{|\arg z| \leq \theta} \|m_z\|_{V^1(\mathbb{R}; \mathbb{C})} \leq \tilde{h}_{p,X} \left(1 + \frac{2}{\cos \theta}\right).$$

Example 8.3.6 (R-analyticity of the heat semigroup revisited). Similar considerations as in Example 8.3.5 also apply to the heat semigroup $(H_t)_{t>0}$ defined by the multiplier $m_t(\xi) = e^{-t(2\pi)^2|\xi|^2}$ and its analytic extension (see also Example 8.2.5). Essentially the same computations give case $d = 1$ of the following bound for $|\arg(z)| < \theta < \pi/2$:

$$\mathcal{R}_p(\{H_z \in \mathcal{L}(L^p(\mathbb{R}^d; X))\}_{|\arg z| \leq \theta}) \leq \tilde{h}_{p,X}^d \left(1 + \frac{2}{\cos \theta}\right)^d.$$

The general case follows by observing that the heat semigroup on $L^p(\mathbb{R}^d; X)$ is a product of one-dimensional heat semigroups in each coordinate direction.

Lemma 8.3.7. *If $f \in V^1(I; X)$ and $\phi \in V^1(I; \mathbb{K}) =: V^1(I)$, then $\phi f \in V^1(I; X)$ and*

$$\|\phi f\|_{V^1(I; X)} \leq \|\phi\|_{V^1(I)} \|f\|_{V^1(I; X)}.$$

Proof. We have

$$\begin{aligned} & \sum_{k=1}^K \|(\phi f)(t_k) - (\phi f)(t_{k-1})\| \\ &= \sum_{k=1}^K \|(\phi(t_k) - \phi(t_{k-1}))f(t_k) + \phi(t_{k-1})(f(t_k) - f(t_{k-1}))\| \\ &\leq \|\phi\|_{\dot{V}^1(I)} \|f\|_{\infty} + \|\phi\|_{\infty} \|f\|_{\dot{V}^1(I; X)}. \end{aligned}$$

Hence

$$\begin{aligned} \|\phi f\|_{V^1(I; X)} &= \|\phi f\|_{\infty} + \|\phi f\|_{\dot{V}^1(I; X)} \\ &\leq \|\phi\|_{\infty} \|f\|_{\infty} + \|\phi\|_{\dot{V}^1(I)} \|f\|_{\infty} + \|\phi\|_{\infty} \|f\|_{\dot{V}^1(I; X)} \\ &\leq (\|\phi\|_{\infty} + \|\phi\|_{\dot{V}^1(I)}) (\|f\|_{\infty} + \|f\|_{\dot{V}^1(I; X)}) \\ &= \|\phi\|_{V^1(I)} \|f\|_{V^1(I; X)}. \end{aligned}$$

□

While the variation norm $\|\cdot\|_{V^1}$ is reasonably workable in this one-dimensional setting, we record its domination by the following related quantities, which become more essential in the higher-dimensional extensions:

Lemma 8.3.8. *For all $f \in C^1(I; X)$ we have*

$$\begin{aligned} \|f\|_{V^1(I; X)} &\leq \sup_{t \in I} \|f(t)\| + \int_I \|f'(t)\| dt =: \|f\|_{\mathcal{V}^1(I; X)} \\ &\leq \sup_{t \in I} \|f(t)\| + |I| \sup_{t \in I} \|f'(t)\| =: \|f\|_{\mathcal{V}_{\infty}^1(I; X)}. \end{aligned}$$

Proof. This is immediate. □

8.3.b The Marcinkiewicz multiplier theorem on the line

The following theorem is the most important result concerning Fourier multipliers on $L^p(\mathbb{R}; X)$. A somewhat weaker version, together with several applications, was already presented in Chapter 5.

Theorem 8.3.9 (Marcinkiewicz multiplier theorem). *Let X and Y be UMD spaces, $p \in (1, \infty)$, and $\mathcal{I} \subseteq \mathcal{L}(X, Y)$ be R -bounded. Let $m : \mathbb{R} \rightarrow \mathcal{L}(X, Y)$ have uniformly \mathcal{I} -bounded variation over the intervals*

$$I \in \mathcal{I} := \{(2^k, 2^{k+1}), (-2^{k+1}, -2^k) : k \in \mathbb{Z}\},$$

in the sense that

$$M := \sup_{I \in \mathcal{I}} \|m\|_{V^1(I; \mathcal{I})} < \infty.$$

Then m defines a Fourier multiplier from $L^p(\mathbb{R}; X)$ to $L^p(\mathbb{R}; Y)$ with norm

$$\|T_m\|_{\mathcal{L}(L^p(\mathbb{R}; X), L^p(\mathbb{R}; Y))} \leq 100 \cdot \beta_{p, X} \beta_{p, Y} \min\{\hbar_{p, X}, \hbar_{p, Y}\} M.$$

The proof will follow the general outline of the proof of Mihlin's multiplier theorem 5.3.18, but using the results above as a substitute of some auxiliary estimates in the said proof. The computation will make decisive use of the auxiliary Littlewood–Paley functions

$$\phi_I(x) := 2|I| \cdot \phi(2|I|x), \quad \widehat{\phi}(\xi) := \frac{\sin^4(\frac{1}{2}\pi\xi)}{(\frac{1}{2}\pi\xi)^2} \quad (8.8)$$

introduced and studied in Chapter 5. We record two facts about these functions proved there: First, we have the Littlewood–Paley type inequality

$$\left\| \sum_{I \in \mathcal{I}_\pm} \varepsilon_I \phi_I * f \right\|_{L^p(\mathbb{R} \times \Omega; X)} \leq \beta_{p, X}^+ \|f\|_{L^p(\mathbb{R}; X)}, \quad (8.9)$$

$$\mathcal{I}_\pm := \{I \in \mathcal{I} : I \subseteq \mathbb{R}_\pm\}$$

proved in Lemma 5.3.22, which is a key point where the UMD property enters into the estimate. Second, there is the variation norm estimate:

Lemma 8.3.10. *We have*

$$\left\| \frac{1}{\widehat{\phi}_I} \right\|_{\mathcal{V}_\infty^1(I; \mathbb{R})} \leq 6.$$

Proof. By definition and a simple change of variable in (8.8), we have

$$\begin{aligned} \left\| \frac{1}{\widehat{\phi}_I} \right\|_{\mathcal{V}_\infty^1(I; \mathbb{R})} &= \sup_{\xi \in I} \frac{1}{|\widehat{\phi}_I(\xi)|} + |I| \sup_{\xi \in I} \left| \left(\frac{1}{\widehat{\phi}_I} \right)'(\xi) \right| \\ &= \sup_{\xi \in [\frac{1}{2}, 1]} \frac{1}{|\widehat{\phi}(\xi)|} + \frac{1}{2} \sup_{\xi \in [\frac{1}{2}, 1]} \left| \left(\frac{1}{\widehat{\phi}} \right)'(\xi) \right| \end{aligned}$$

$$\leq \frac{\pi^2}{4} + \frac{1}{2} \cdot 2\pi < 6,$$

where the penultimate estimate was made in Lemma 5.3.23. \square

Proof of Theorem 8.3.9. Let us fix a function $f \in \mathcal{S}(\mathbb{R}; X) \subseteq \tilde{L}^1(\mathbb{R}; X)$, so that $T_m f \in \tilde{L}^1(\mathbb{R}; Y)$. We will estimate its $L^p(\mathbb{R}; Y)$ -norm by dualising with $g \in \mathcal{S}(\mathbb{R}; Y^*)$, a norming subspace of the dual space. Using the basic properties of the Fourier transform, we compute:

$$\begin{aligned} |\langle T_m f, g \rangle| &= |\langle m \hat{f}, \check{g} \rangle| = \left| \sum_{I \in \mathcal{I}} \langle \mathbf{1}_I m \hat{f}, \check{g} \rangle \right| \\ &= \left| \sum_{\sigma \in \{-, +\}} \sum_{I \in \mathcal{I}_\sigma} \left\langle \frac{\mathbf{1}_I m}{\widehat{\phi_I} \check{\phi_I}} \widehat{\phi_I} \hat{f}, \check{\phi_I} \check{g} \right\rangle \right|, \quad \mathcal{I}_\sigma := \{I \in \mathcal{I} : I \subseteq \mathbb{R}_\sigma\}, \\ &= \left| \sum_{\sigma \in \{-, +\}} \mathbb{E} \left\langle \sum_{I \in \mathcal{I}_\sigma} \varepsilon_I m_I \widehat{\phi_I} \hat{f}, \sum_{I \in \mathcal{I}_\sigma} \bar{\varepsilon}_I \check{\phi_I} \check{g} \right\rangle \right|, \quad m_I := \frac{\mathbf{1}_I m}{\widehat{\phi_I} \check{\phi_I}}, \\ &= \left| \sum_{\sigma \in \{-, +\}} \mathbb{E} \left\langle \sum_{I \in \mathcal{I}_\sigma} \varepsilon_I T_{m_I}(\phi_I * f), \sum_{I \in \mathcal{I}_\sigma} \bar{\varepsilon}_I \phi_I * g \right\rangle \right| \\ &\leq \sum_{\sigma \in \{-, +\}} \left\| \sum_{I \in \mathcal{I}_\sigma} \varepsilon_I T_{m_I}(\phi_I * f) \right\|_{L^p(\mathbb{R} \times \Omega; Y)} \left\| \sum_{I \in \mathcal{I}_\sigma} \bar{\varepsilon}_I \phi_I * g \right\|_{L^{p'}(\mathbb{R} \times \Omega; Y^*)} \\ &\leq \sum_{\sigma \in \{-, +\}} \sup_{I \in \mathcal{I}} \|m_I\|_{V^1(I; \mathcal{I})} \mathcal{R}_p(\mathcal{I}) \min\{\hbar_{p, X}, \hbar_{p, Y}\} \\ &\quad \times \left\| \sum_{I \in \mathcal{I}_\sigma} \varepsilon_I \phi_I * f \right\|_{L^p(\mathbb{R} \times \Omega; X)} \left\| \sum_{I \in \mathcal{I}_\sigma} \bar{\varepsilon}_I \phi_I * g \right\|_{L^{p'}(\mathbb{R} \times \Omega; Y^*)} \\ &\quad \text{by Theorem 8.3.4} \\ &\leq \sum_{\sigma \in \{-, +\}} \sup_{I \in \mathcal{I}} \|m_I\|_{V^1(I; \mathcal{I})} \mathcal{R}_p(\mathcal{I}) \min\{\hbar_{p, X}, \hbar_{p, Y}\} \\ &\quad \times \beta_{p, X}^+ \|f\|_{L^p(\mathbb{R}; X)} \cdot \beta_{p', Y^*}^+ \|g\|_{L^{p'}(\mathbb{R}; Y^*)} \\ &\quad \text{by (8.9) both in } L^p(\mathbb{R}; X) \text{ and in } L^{p'}(\mathbb{R}; Y^*). \end{aligned}$$

This is a bound of the asserted form, except for the quantities $\|m_I\|_{V^1(I; \mathcal{I})}$ in place of $\|m\|_{V^1(I; \mathcal{I})}$. But

$$\|m_I\|_{V^1(I; \mathcal{I})} = \left\| \frac{m}{\widehat{\phi_I} \check{\phi_I}} \right\|_{V^1(I; \mathcal{I})} \leq \left\| \frac{1}{\widehat{\phi_I}} \right\|_{\mathcal{Y}_\infty^1(I; \mathbb{R})}^2 \|m\|_{V^1(I; \mathcal{I})} \leq 6^2 \|m\|_{V^1(I; \mathcal{I})}$$

by Lemmas 8.3.7 and 8.3.8 in the second to last step, and Lemma 8.3.10 in the last one. Hence

$$\begin{aligned} \|T_m\|_{\mathcal{L}(L^p(\mathbb{R}; X), L^p(\mathbb{R}; Y))} \\ \leq \sum_{\sigma \in \{-, +\}} \sup_{I \in \mathcal{I}} \|m_I\|_{V^1(I; \mathcal{I})} \mathcal{R}_p(\mathcal{I}) \min\{\hbar_{p, X}, \hbar_{p, Y}\} \beta_{p, X}^+ \beta_{p', Y^*}^+ \end{aligned}$$

$$\leq 2 \sup_{I \in \mathcal{I}} (6^2 \|m\|_{V^1(I; \mathcal{T})}) \mathcal{R}_p(\mathcal{T}) \min\{\hbar_{p,X}, \hbar_{p,Y}\} \beta_{p,X}^+ \beta_{p',Y^*}^+,$$

which is the asserted bound, after estimating $2 \cdot 6^2 < 100$ and $\beta_{p,X}^+ \leq \beta_{p,X}$, $\beta_{p',Y^*}^+ \leq \beta_{p',Y^*} = \beta_{p,Y}$. \square

As an immediate corollary we obtain the following result, also contained (aside from an unimportant numerical factor) in Theorem 5.3.18:

Corollary 8.3.11 (Mihlin's multiplier theorem). *Let X and Y be UMD spaces, and $p \in (1, \infty)$. Let $m \in C^1(\mathbb{R} \setminus \{0\}; \mathcal{L}(X, Y))$ satisfy*

$$M := \mathcal{R}_p(\{m(\xi), \xi m'(\xi) : \xi \in \mathbb{R} \setminus \{0\}\}) < \infty.$$

Then m defines a Fourier multiplier from $L^p(\mathbb{R}; X)$ to $L^p(\mathbb{R}; Y)$ with norm

$$\|T_m\|_{\mathcal{L}(L^p(\mathbb{R}; X), L^p(\mathbb{R}; Y))} \leq 200 \cdot \beta_{p,X} \beta_{p,Y} \min\{\hbar_{p,X}, \hbar_{p,Y}\} M.$$

Proof. Let \mathcal{T} be the closure of the absolute convex hull of $\{m(\xi), \{|\xi| m'(\xi) : \xi \in \mathbb{R} \setminus \{0\}\}$. For $I \in \mathcal{I}$, we have

$$\|m\|_{\dot{V}^1(I; \mathcal{T})} \leq \int_I \|m'(\xi)\|_{\mathcal{T}} d\xi \leq \int_I \frac{1}{|\xi|} d\xi = \log 2.$$

Thus

$$\|m\|_{V^1(I; \mathcal{T})} = \sup_{\xi \in I} \|m(\xi)\|_{\mathcal{T}} + \|m\|_{\dot{V}^1(I; \mathcal{T})} \leq 1 + \log 2 < 2.$$

By Theorem 8.3.9, we have

$$\begin{aligned} & \|T_m\|_{\mathcal{L}(L^p(\mathbb{R}; X), L^p(\mathbb{R}; Y))} \\ & \leq 100 \cdot \beta_{p,X} \beta_{p,Y} \min\{\hbar_{p,X}, \hbar_{p,Y}\} \sup_{I \in \mathcal{I}} \|m\|_{V^1(I; \mathcal{T})} \mathcal{R}_p(\mathcal{T}) \\ & \leq 100 \cdot \beta_{p,X} \beta_{p,Y} \min\{\hbar_{p,X}, \hbar_{p,Y}\} \cdot 2 \cdot M, \end{aligned}$$

as claimed. \square

Under the additional assumption of Pisier's contraction property, R -boundedness also appears as a conclusion on large classes of the operators T_m themselves. This stronger assumption is also necessary for this kind of conclusions, as we show in Proposition 8.3.24 below.

Theorem 8.3.12 (Venni). *Let X and Y be UMD spaces with Pisier's contraction property. Let $p \in (1, \infty)$ and $\mathcal{T} \subseteq \mathcal{L}(X, Y)$ be an R -bounded set. Let $\mathcal{M}_{\mathcal{T}} \subseteq C^1(\mathbb{R} \setminus \{0\}; \mathcal{L}(X, Y))$ be the collection of all multipliers that satisfy*

$$\{m(\xi), \xi m'(\xi) : \xi \in \mathbb{R} \setminus \{0\}\} \subseteq \mathcal{T}.$$

Then $\{T_m : m \in \mathcal{M}_{\mathcal{T}}\} \subseteq \mathcal{L}(L^p(\mathbb{R}; X), L^p(\mathbb{R}; Y))$ is R -bounded, and in fact

$$\mathcal{R}_p(\{T_m : m \in \mathcal{M}_{\mathcal{T}}\}) \leq 200 \cdot \alpha_{p,X}^+ \alpha_{p,Y}^- \beta_{p,X} \beta_{p,Y} \min\{\hbar_{p,X}, \hbar_{p,Y}\} \mathcal{R}_p(\mathcal{T}).$$

Proof. By Proposition 8.1.17 it suffices to prove a uniform bound for the diagonal operators $(T_{m_n})_{n=1}^N$ acting from $\varepsilon_N^p(L^p(\mathbb{R}; X)) \simeq L^p(\mathbb{R}; \varepsilon_N^p(X))$ to $\varepsilon_N^p(L^p(\mathbb{R}; Y)) \simeq L^p(\mathbb{R}; \varepsilon_N^p(Y))$, where the identifications of the spaces are isometric. Under these identifications, we observe that $(T_{m_n})_{n=1}^N$ coincides with the Fourier multiplier $T_{\tilde{m}}$ with diagonal-operator-valued symbol $\tilde{m}(\xi) = (m_n(\xi))_{n=1}^N \in \mathcal{L}(\varepsilon_N^p(X), \varepsilon_N^p(Y))$.

Since $m_n(\xi), \xi m'_n(\xi) \in \mathcal{T}$ for each n , it follows that $\tilde{m}(\xi), \xi \tilde{m}'(\xi) \in \widetilde{\mathcal{T}}_N$, where $\widetilde{\mathcal{T}}_N$ is defined in Proposition 8.1.18. The aforementioned proposition guarantees that $\mathcal{R}_p(\widetilde{\mathcal{T}}_N) \leq \alpha_{p,X}^+ \alpha_{p,Y}^- \mathcal{R}_p(\mathcal{T})$. Thus the multiplier \tilde{m} is in the scope of Corollary 8.3.11 with X and Y replaced by $\varepsilon_N^p(X)$ and $\varepsilon_N^p(Y)$, and $M \leq \alpha_{p,X}^+ \alpha_{p,Y}^- \mathcal{R}_p(\mathcal{T})$. Since, by Fubini's theorem,

$$\beta_{p, \varepsilon_N^p(X)} = \beta_{p,X}, \quad \hbar_{p, \varepsilon_N^p(X)} = \hbar_{p,X},$$

and likewise for Y in place of X , the claim of the theorem follows from Corollary 8.3.11 via the said identifications. \square

8.3.c Multipliers of bounded rectangular variation

We now turn to an extension of the results of the previous sections to several variables. The theory is unfortunately burdened by somewhat heavy notation, but the patient reader will hopefully be rewarded by a reasonably clean formulation of the main theorems in the following subsection.

The analogue of Proposition 8.3.1 is fairly immediate:

Lemma 8.3.13. *Let \mathcal{J}^d be the collection of all axes-parallel rectangles in \mathbb{R}^d , i.e., rectangles which are products of intervals in each coordinate. Then*

$$\mathcal{R}_p\{\Delta_R \in \mathcal{L}(L^p(\mathbb{R}^d; X)) : R \in \mathcal{J}^d\} \leq \hbar_{p,X}^d.$$

Proof. By Fubini's theorem, if m is a Fourier multiplier for $L^p(\mathbb{R}; X)$, then $\xi \mapsto m(\xi_i)$ is a Fourier multiplier for $L^p(\mathbb{R}^d; X)$ for any $i = 1, \dots, d$. So using $\mathbf{1}_{I_1 \times \dots \times I_d}(\xi) = \mathbf{1}_{I_1}(\xi_1) \cdots \mathbf{1}_{I_d}(\xi_d)$, the lemma is an immediate corollary of the one-dimensional case (Proposition 8.3.1) and the product rule for R -bounds (Proposition 8.1.19). \square

In order to define a workable version of bounded variation in several variables, we need to introduce some notation. For a function α defined on the integer lattice \mathbb{Z}^d , we denote

$$\Delta_i \alpha(k) := \alpha(k) - \alpha(k - e_i)$$

and, for $\beta \in \{0, 1\}^d$,

$$\Delta^\beta := \prod_{i: \beta_i=1} \Delta_i.$$

For a set \mathcal{X} , we let $\mathcal{X}^\beta := \mathcal{X}^{|\beta|}$ as a set, but we index the components of $x \in \mathcal{X}^\beta$ by the positions of the non-zero components of β , e.g., if $\beta = (0, 1, 1)$, then a typical element of \mathcal{X}^β is written as $x_\beta = (x_2, x_3)$. In particular, we denote by 0_β the vector of $|\beta|$ zeros.

Writing $\mathbf{1} := (1, 1, \dots, 1)$ (d times) we will frequently split $\mathcal{X}^d = \mathcal{X}^{1-\beta} \times \mathcal{X}^\beta$, leading to a representation of a generic element $x \in \mathcal{X}^d$ as $x = (x_{1-\beta}, x_\beta)$. If $d = 3$ and $\beta = (0, 1, 1)$, we have $\mathbf{1} - \beta = (1, 0, 0)$, and $x = (x_{1-\beta}, x_\beta) = (x_1, (x_2, x_3))$

Definition 8.3.14. Let $R = I_1 \times \dots \times I_d \subseteq \mathbb{R}^d$ be a rectangle, and X be a normed space. A function $f : R \rightarrow X$ is said to have bounded rectangular variation, if

$$\|f\|_{V^1(R; X)} := \sup_\lambda \sum_{\beta \in \{0,1\}^d} \sum_{\substack{j_\beta \in \mathbb{N}^\beta \\ 0_\beta < j_\beta \leq K_\beta}} \|\Delta^\beta(f \circ \lambda)(0_{1-\beta}, j_\beta)\| < \infty,$$

where the supremum is over all finite rectangular lattices, interpreted as mappings

$$\lambda = (\lambda_1, \dots, \lambda_d), \quad \lambda_i : \{0, 1, \dots, K_i\} \rightarrow I_i \text{ increasing,}$$

where the lattice size $K = (K_1, \dots, K_d) \in \mathbb{Z}_+^d$ is also arbitrary.

We denote by $\tilde{V}^1(R; X)$ the space of all $f \in V^1(R; X)$ that are continuous at almost every point of R .

Proposition 8.3.15. Let X or Y (sic!) be a UMD space, and $p \in (1, \infty)$. Let $\mathcal{T} \subseteq \mathcal{L}(X, Y)$ be a closed, absolutely convex, R -bounded set. Then all $m \in \tilde{V}^1(R; \mathcal{T})$, with R a rectangle in \mathbb{R}^d , give rise to

$$T_{m\mathbf{1}_R} \in \mathcal{L}(L^p(\mathbb{R}^d; X), L^p(\mathbb{R}^d; Y)),$$

and moreover

$$\begin{aligned} \mathcal{R}_p(\{T_{m\mathbf{1}_R} : m \in \tilde{V}^1(\mathbb{R}; \mathcal{T}), \|m\|_{V^1(R; \mathcal{T})} \leq M, R \in \mathcal{J}^d\}) \\ \leq M \min\{\hbar_{p, X}, \hbar_{p, Y}\}^d \mathcal{R}_p(\mathcal{T}). \end{aligned}$$

Proof. Let first $m \in V^1(R; \mathcal{T})$, and then also $m\mathbf{1}_R$, be a step function

$$m\mathbf{1}_R = \sum_{\substack{k \in \mathbb{N}^d \\ k \leq K}} \alpha(k) \mathbf{1}_{R_k},$$

where $R_k = I_{k_1}^1 \times \dots \times I_{k_d}^d$, $I_0^i = (a^i, a_0^i)$, $I_{k_i}^i = [a_{k_i-1}^i, a_{k_i}^i)$ for $k_i = 1, \dots, K_i - 1$, and $I_{K_i}^i = [a_{K_i-1}^i, b^i)$ for some $-\infty \leq a^i < a_0^i < a_1^i < \dots < a_{K_i-1}^i < b^i \leq \infty$, for $i = 1, \dots, d$.

We write

$$\begin{aligned}\alpha(k) &= \sum_{\beta \in \{0,1\}^d} \sum_{\substack{j_\beta \in \mathbb{N}^\beta \\ 0_\beta < j_\beta \leq k_\beta}} \Delta^\beta \alpha(0_{\mathbf{1}-\beta}, j_\beta), \\ m \mathbf{1}_R &= \sum_{\beta \in \{0,1\}^d} \sum_{\substack{j_\beta \in \mathbb{N}^\beta \\ 0_\beta < j_\beta \leq K_\beta}} \Delta^\beta \alpha(0_{\mathbf{1}-\beta}, j_\beta) \sum_{\substack{k \in \mathbb{N}^d \\ j_\beta \leq k_\beta; k \leq K}} \mathbf{1}_{R_k}.\end{aligned}$$

Here the last sum is the indicator of some $S_{\beta, j_\beta} \in \mathcal{J}^d$, while

$$\sum_{\beta \in \{0,1\}^d} \sum_{\substack{j_\beta \in \mathbb{N}^\beta \\ 0_\beta < j_\beta \leq K_\beta}} \|\Delta^\beta \alpha(0_{\mathbf{1}-\beta}, j_\beta)\|_{\mathcal{J}} \leq \|m\|_{V^1(R; \mathcal{J})} \leq M$$

by definition of rectangular variation. Thus

$$T_{m \mathbf{1}_R} = \sum_{\beta \in \{0,1\}^d} \sum_{\substack{j_\beta \in \mathbb{N}^\beta \\ 0_\beta < j_\beta \leq K_\beta}} \Delta^\beta \alpha(0_{\mathbf{1}-\beta}, j_\beta) \Delta_{S_{\beta, j_\beta}} \in M \operatorname{conv}(\mathcal{T} \Delta_{\mathcal{J}^d}) =: \widetilde{\mathcal{T}}$$

for all such multipliers m , where

$$\mathcal{R}_p(\widetilde{\mathcal{T}}) \leq M \min\{h_{p,X}, h_{p,Y}\}^d \mathcal{R}_p(\mathcal{T}) =: \widetilde{M}.$$

The minimum comes from the fact that all $T \in \mathcal{T}$ and $\Delta_S \in \Delta_{\mathcal{J}^d}$ commute, so that one can use the R -boundedness of $\Delta_{\mathcal{J}^d}$ on either $L^p(\mathbb{R}^d; X)$ or $L^p(\mathbb{R}^d; Y)$, and take the smaller of the resulting bounds.

For a general $m \in \widetilde{V}^1(R; \mathcal{J})$ in the set under consideration, we first consider approximating step functions $m^{(k)}$ defined as follows: On each dyadic cubes Q of side-length 2^{-k} and contained in $R^{(k)} := [-2^k, 2^k]^d \cap R$, the function $m^{(k)}$ takes the constant value $m(a_Q)$, where $Q = a_Q + 2^{-k}[0, 1]^d$. On all other dyadic cubes Q of the same side-length, $m^{(k)}$ takes the constant value $m(a_{Q'})$, where $a_{Q'}$ is nearest to a_Q among the those Q' contained in $R^{(k)}$.

It follows that $m^{(k)}(\xi) \rightarrow m(\xi)$ at all points of continuity of m , which is almost everywhere on R for $m \in \widetilde{V}^1(\mathbb{R}; X)$. For $f \in \widetilde{L}^1(\mathbb{R}^d; X)$, it follows from dominated convergence that

$$T_{m \mathbf{1}_R} f(x) = \int_R m(\xi) \widehat{f}(\xi) e^{i2\pi\xi x} d\xi = \lim_{k \rightarrow \infty} T_{m^{(k)} \mathbf{1}_R} f(x),$$

where the multipliers $m^{(k)}$ have the form considered in the first part of the proof.

We apply this observation to N functions $f_n \in L^p(\mathbb{R}^d; X) \cap \widetilde{L}^1(\mathbb{R}^d; X)$, multipliers m_n and rectangles R_n , and use Fatou's lemma to deduce that

$$\left\| \sum_{n=1}^N \varepsilon_n T_{m_n \mathbf{1}_{R_n}} f_n \right\|_{L^p(\mathbb{R}^d \times \Omega; Y)} \leq \liminf_{k \rightarrow \infty} \left\| \sum_{n=1}^N \varepsilon_n T_{m_n^{(k)} \mathbf{1}_{R_n}} f_n \right\|_{L^p(\mathbb{R}^d \times \Omega; Y)}$$

$$\leq \widetilde{M} \left\| \sum_{n=1}^N \varepsilon_n f_n \right\|_{L^p(\mathbb{R}^d \times \Omega; X)}$$

by the case of step functions already considered. By density, this proves in particular the boundedness of each $T_{m_{1R}}$, and then also the R -boundedness of the full collection, as stated. \square

We provide the following workable condition for estimating the rectangular variation of a function:

Lemma 8.3.16. *Under the above assumptions,*

$$\begin{aligned} \|f\|_{V^1(R; X)} &\leq \sum_{\beta \in \{0,1\}^d} \sup_{\xi \in R_{1-\beta}} \int_{R_\beta} \|\partial^\beta f(\xi)\| \, d\xi_\beta =: \|f\|_{\mathcal{V}^1(R; X)} \\ &\leq \sum_{\beta \in \{0,1\}^d} |R_\beta| \sup_{\xi \in R} \|\partial^\beta f\| =: \|f\|_{\mathcal{V}_\infty^1(R; X)}, \end{aligned}$$

where $|R_\beta|$ is the $|\beta|$ -dimensional Lebesgue measure of R_β (interpreted as 1 for $\beta = 0$).

Proof. The second estimate is obvious. The first one depends on the basic identity

$$\Delta^\beta \alpha(j) = \int_{(j-1)_\beta, j_\beta} \partial^\beta \alpha(\xi) \, d\xi_\beta,$$

which reduces to the fundamental theorem of calculus for $|\beta| = 1$, and can be checked by induction on $|\beta|$ in the general case.

Thus, turning to the expression appearing in the formula of $\|f\|_{V^1(R; X)}$,

$$\begin{aligned} &\sum_{\substack{j_\beta \in \mathbb{N}^\beta \\ 0_\beta < j_\beta \leq K_\beta}} \|\Delta^\beta (f \circ \lambda)(0_{1-\beta}, j_\beta)\| \\ &\leq \sum_{\substack{j_\beta \in \mathbb{N}^\beta \\ 0_\beta < j_\beta \leq K_\beta}} \int_{(\lambda(j-1)_\beta, \lambda(j)_\beta)} \|(\Delta^\beta f)(\lambda_{1-\beta}(0_{1-\beta}), \xi_\beta)\| \, d\xi_\beta \\ &\leq \int_{R_\beta} \|(\Delta^\beta f)(\lambda_{1-\beta}(0_{1-\beta}), \xi_\beta)\| \, d\xi_\beta \\ &\leq \sup_{\xi_{1-\beta} \in R_{1-\beta}} \int_{R_\beta} \|(\Delta^\beta f)(\xi)\| \, d\xi_\beta. \end{aligned}$$

Summing over $\beta \in \{0,1\}^d$ and taking the supremum over the rectangular lattices λ proves the lemma. \square

Lemma 8.3.17. *Let $f \in \mathcal{V}^1(R; X)$ and $\phi \in \mathcal{V}_\infty^1(R; \mathbb{K}) =: \mathcal{V}_\infty^1(R)$. Then $\phi f \in \mathcal{V}^1(R; X)$ and*

$$\|\phi f\|_{\mathcal{V}^1(R; X)} \leq \|\phi\|_{\mathcal{V}_\infty^1(R)} \|f\|_{\mathcal{V}^1(R; X)}.$$

Proof. Let us denote $c_\beta := |R_\beta| \|\partial^\beta \phi\|_\infty$. We have

$$\partial^\beta(\phi f) = \sum_{\gamma \leq \beta} \partial^{\beta-\gamma} \phi \partial^\gamma f,$$

hence

$$\begin{aligned} \int_{R_\beta} \|\partial^\beta(\phi f)(\xi)\| \, d\xi_\beta &\leq \sum_{\gamma \leq \beta} \int_{R_{\beta-\gamma}} \int_{R_\gamma} \frac{c_{\beta-\gamma}}{|R_{\beta-\gamma}|} \|\partial^\gamma f\| \, d\xi_\gamma \, d\xi_{\beta-\gamma} \\ &\leq \sum_{\gamma \leq \beta} c_{\beta-\gamma} \sup_{\xi \in R_{\beta-\gamma}} \int_{R_\gamma} \|\partial^\gamma f\| \, d\xi_\gamma, \end{aligned}$$

and thus

$$\begin{aligned} \|\phi f\|_{\mathcal{V}^1(R;X)} &= \sum_{\beta \in \{0,1\}^d} \sup_{\xi_{1-\beta} \in R_{1-\beta}} \int_{R_\beta} \|\partial^\beta(\phi f)(\xi)\| \, d\xi_\beta \\ &\leq \sum_{\beta \in \{0,1\}^d} \sum_{\gamma \leq \beta} c_{\beta-\gamma} \sup_{\xi_{1-\beta} \in R_{1-\beta}} \sup_{\xi_{\beta-\gamma} \in R_{\beta-\gamma}} \int_{R_\gamma} \|\partial^\gamma f\| \, d\xi_\gamma \\ &= \sum_{\gamma \in \{0,1\}^d} \sum_{\beta \geq \gamma} c_{\beta-\gamma} \sup_{\xi_{1-\gamma} \in R_{1-\gamma}} \int_{R_\gamma} \|\partial^\gamma f\| \, d\xi_\gamma, \end{aligned}$$

where $\sum_{\beta \geq \gamma} c_{\beta-\gamma} \leq \sum_{\beta \in \{0,1\}^d} c_\beta = \|\phi\|_{\mathcal{V}_\infty^1(R)}$, and the remaining terms are bounded by $\|f\|_{\mathcal{V}^1(R;X)}$. \square

Lemma 8.3.18. *For a function of the product form $\phi = \prod_{i=1}^d \phi^{(i)}$, where $\phi^{(i)}(x) = \phi^{(i)}(x_i)$, we have*

$$\|\phi\|_{\mathcal{V}_\infty^1(R)} = \prod_{i=1}^d \|\phi^{(i)}\|_{\mathcal{V}_\infty^1(I_i)}, \quad R = I_1 \times \cdots \times I_d.$$

Proof. We have

$$\partial^\beta \phi(\xi) = \left(\prod_{i:\beta_i=1} (\phi^{(i)})'(\xi_i) \right) \left(\prod_{i:\beta_i=0} \phi^{(i)}(\xi_i) \right), \quad |R_\beta| = \prod_{i:\beta_i=1} |I_i|,$$

and hence

$$|R_\beta| \|\partial^\beta \phi\|_{L^\infty(R)} = \left(\prod_{i:\beta_i=1} |I_i| \|\phi^{(i)}\|_{L^\infty(I_i)} \right) \left(\prod_{i:\beta_i=0} \|\phi^{(i)}\|_{L^\infty(I_i)} \right).$$

Summing over $\beta \in \{0,1\}^d$,

$$\begin{aligned} \|\phi\|_{\mathcal{V}_\infty^1(R)} &= \sum_{\beta \in \{0,1\}^d} |R_\beta| \|\partial^\beta \phi\|_{L^\infty(R)} \\ &= \prod_{i=1}^d \left(\|\phi^{(i)}\|_{L^\infty(I_i)} + |I_i| \|\phi^{(i)}\|_{L^\infty(I_i)} \right) = \prod_{i=1}^d \|\phi^{(i)}\|_{\mathcal{V}_\infty^1(I_i)}. \end{aligned}$$

\square

8.3.d The product-space multiplier theorem

Broadly speaking, *product-space theory* (also known as *multi-parameter theory*) on \mathbb{R}^d refers to the explicit interpretation of this space as $\mathbb{R} \times \dots \times \mathbb{R}$ (d times), or sometimes more generally as $\mathbb{R}^{d_1} \times \dots \times \mathbb{R}^{d_N}$ ($d_1 + \dots + d_N = d$), in such a way that the objects under consideration are allowed to behave somewhat independently in all the different coordinate directions. In the specific context of Fourier multipliers, we are interested in multiplier classes that are preserved by multi-parameter dilations of the form

$$m \mapsto m_{(\lambda_1, \dots, \lambda_d)}, \quad m_{(\lambda_1, \dots, \lambda_d)}(\xi) := m(\lambda_1 \xi_1, \dots, \lambda_d \xi_d),$$

rather than just the isotropic one parameter dilations corresponding to the case $\lambda_1 = \dots = \lambda_d = \lambda$. The main result concerning product-space Fourier multipliers reads as follows:

Theorem 8.3.19 (Marcinkiewicz multiplier theorem in \mathbb{R}^d). *Let X and Y be UMD spaces with Pisier’s contraction property, $p \in (1, \infty)$, and $\mathcal{T} \subseteq \mathcal{L}(X, Y)$ be R -bounded. Let $m : \mathbb{R} \rightarrow \mathcal{L}(X, Y)$ have uniformly \mathcal{T} -bounded variation over the rectangles*

$$R \in \mathcal{J}^d := \{(2^k, 2^{k+1}), (-2^{k+1}, -2^k) : k \in \mathbb{Z}\}^d,$$

in the sense that

$$M := \sup_{R \in \mathcal{J}^d} \|m\|_{\mathcal{V}^1(R; \mathcal{T})} < \infty.$$

Then m defines a Fourier multiplier from $L^p(\mathbb{R}; X)$ to $L^p(\mathbb{R}; Y)$ with norm

$$\begin{aligned} \|T_m\|_{\mathcal{L}(L^p(\mathbb{R}^d; X), L^p(\mathbb{R}^d; Y))} \\ \leq (100\beta_{p,X}\beta_{p,Y} \min\{h_{p,X}, h_{p,Y}\})^d (\alpha_{p,Y}^- \alpha_{p,X}^+)^{d-1} \mathcal{R}_p(\mathcal{T})M. \end{aligned}$$

For $R = I_1 \times \dots \times I_d \in \mathcal{J}^d$, we define the function

$$\phi_R := \prod_{i=1}^d \phi_{I_i}^{(i)}, \quad \phi_{I_i}^{(i)}(x) := \phi_{I_i}(x_i),$$

where the one-variable functions ϕ_{I_i} are those defined in (8.8). Let also

$$\varepsilon_R := \prod_{i=1}^d \varepsilon_{I_i}^{(i)}$$

be a product of independent Rademacher variables $\varepsilon_{I_i}^{(i)}$, where we assume that $\varepsilon_{I_i}^{(i)}$ is defined on the i th factor of a product probability space Ω^d .

Lemma 8.3.20. For each $\sigma = (\sigma_1, \dots, \sigma_d) \in \{-, +\}^d$, we have

$$\left\| \sum_{R \in \mathcal{J}_\sigma^d} \varepsilon_R \phi_R * f \right\|_{L^p(\mathbb{R}^d \times \Omega^d; X)} \leq (\beta_{p, X}^+)^d \|f\|_{L^p(\mathbb{R}^d; X)},$$

$$\mathcal{J}_\sigma^d := \mathcal{J}_{\sigma_1} \times \dots \times \mathcal{J}_{\sigma_d}.$$

Proof. The expression on the right splits into a product form:

$$\sum_{R \in \mathcal{J}_\sigma^d} \varepsilon_{I_1}^{(1)} \cdots \varepsilon_{I_d}^{(d)} \phi_R * f = \left(\sum_{I_1 \in \mathcal{J}} \varepsilon_{I_1}^{(1)} \phi_{I_1}^{(1)} \right) *_1 \cdots \left(\sum_{I_d \in \mathcal{J}} \varepsilon_{I_d}^{(d)} \phi_{I_d}^{(d)} \right) *_d f,$$

where $*_i$ is the convolution with respect to the x_i variable only. By (8.9), each of the factors $(\sum_{I_i \in \mathcal{J}} \varepsilon_{I_i}^{(i)} \phi_{I_i}^{(i)}) *_i$ maps $L^p(\mathbb{R}; X)$ (of the x_i variable) into $L^p(\mathbb{R} \times \Omega; X)$ with norm at most $\beta_{p, X}^+$; a d -fold application of this observation together with Fubini's theorem proves the claim. \square

Lemma 8.3.21.

$$\left\| \frac{1}{\widehat{\phi}_R} \right\|_{\mathcal{V}_\infty^1(R)} \leq 6^d.$$

Proof. Since the function to be estimated takes the product form

$$\frac{1}{\widehat{\phi}_R(\xi)} = \prod_{i=1}^d \frac{1}{\widehat{\phi}_{I_i}(\xi_i)}, \quad R = I_1 \times \dots \times I_d,$$

Lemma 8.3.18 applies and gives the identity

$$\left\| \frac{1}{\widehat{\phi}_R} \right\|_{\mathcal{V}_\infty^1(R)} = \prod_{i=1}^d \left\| \frac{1}{\widehat{\phi}_{I_i}} \right\|_{\mathcal{V}_\infty^1(I_i)},$$

and the asserted bound for the right-hand side follows at once from Lemma 8.3.10. \square

Proof of Theorem 8.3.19. We follow the proof of Theorem 8.3.9 with minor modifications. Let us fix a function $f \in \mathcal{S}(\mathbb{R}^d; X) \subseteq \check{L}^1(\mathbb{R}^d; X)$, so that $T_m f \in \check{L}^1(\mathbb{R}^d; Y)$. We will estimate its $L^p(\mathbb{R}^d; Y)$ -norm by dualising with $g \in \mathcal{S}(\mathbb{R}^d; Y^*)$, a norming subspace of the dual space. Using the basic properties of the Fourier transform, we compute:

$$\begin{aligned} |\langle T_m f, g \rangle| &= |\langle m \widehat{f}, \check{g} \rangle| = \left| \sum_{R \in \mathcal{J}^d} \langle \mathbf{1}_R m \widehat{f}, \check{g} \rangle \right| \\ &= \left| \sum_{\sigma \in \{\pm\}^d} \sum_{R \in \mathcal{J}_\sigma^d} \left\langle \frac{\mathbf{1}_R m}{\widehat{\phi}_R \check{\phi}_R} \widehat{\phi}_R \widehat{f}, \check{\phi}_R \check{g} \right\rangle \right| \\ &= \left| \sum_{\sigma \in \{\pm\}^d} \mathbb{E} \left\langle \sum_{R \in \mathcal{J}_\sigma^d} \varepsilon_R m_R \widehat{\phi}_R \widehat{f}, \sum_{R \in \mathcal{J}_\sigma^d} \bar{\varepsilon}_R \check{\phi}_R \check{g} \right\rangle \right|, \quad m_R := \frac{\mathbf{1}_R m}{\widehat{\phi}_R \check{\phi}_R}, \end{aligned}$$

$$\begin{aligned}
 &= \left| \sum_{\sigma \in \{\pm\}^d} \mathbb{E} \left\langle \sum_{R \in \mathcal{I}_\sigma^d} \varepsilon_R T_{m_R}(\phi_R * f), \sum_{R \in \mathcal{I}_\sigma^d} \bar{\varepsilon}_R \phi_R * g \right\rangle \right| \\
 &\leq \sum_{\sigma \in \{\pm\}^d} \left\| \sum_{R \in \mathcal{I}_\sigma^d} \varepsilon_R T_{m_R}(\phi_R * f) \right\|_{L^p(\mathbb{R}^d \times \Omega^d; Y)} \left\| \sum_{R \in \mathcal{I}_\sigma^d} \bar{\varepsilon}_R \phi_R * g \right\|_{L^{p'}(\mathbb{R}^d \times \Omega^d; Y^*)},
 \end{aligned}$$

where

$$\left\| \sum_{R \in \mathcal{I}_\sigma^d} \bar{\varepsilon}_R \phi_R * g \right\|_{L^{p'}(\mathbb{R}^d \times \Omega^d; Y^*)} \leq (\beta_{p', Y^*})^d \|g\|_{L^{p'}(\mathbb{R}^d; Y^*)}$$

by Lemma 8.3.20. For the factor involving the multipliers T_{m_R} , we first apply the contraction property and then Proposition 8.3.15 to arrive at

$$\begin{aligned}
 &\left\| \sum_{R \in \mathcal{I}_\sigma^d} \varepsilon_R T_{m_R}(\phi_R * f) \right\|_{L^p(\mathbb{R}^d \times \Omega^d; Y)} \\
 &\leq (\alpha_{p, Y}^-)^{d-1} \left\| \sum_{R \in \mathcal{I}_\sigma^d} \varepsilon_R T_{m_R}(\phi_R * f) \right\|_{L^p(\mathbb{R}^d \times \Omega; Y)} \\
 &\leq (\alpha_{p, Y}^-)^{d-1} \sup_{R \in \mathcal{I}_\sigma^d} \|m_R\|_{V^1(R; \mathcal{I})} \mathcal{R}_p(\mathcal{I}) \min\{h_{p, X}, h_{p, Y}\}^d \\
 &\quad \times \left\| \sum_{R \in \mathcal{I}_\sigma^d} \varepsilon_R \phi_R * f \right\|_{L^p(\mathbb{R}^d \times \Omega; X)}.
 \end{aligned}$$

Another application of the contraction property, followed by Lemma 8.3.20, gives

$$\begin{aligned}
 \left\| \sum_{R \in \mathcal{I}_\sigma^d} \varepsilon_R \phi_R * f \right\|_{L^p(\mathbb{R}^d \times \Omega; X)} &\leq (\alpha_{p, X}^+)^{d-1} \left\| \sum_{R \in \mathcal{I}_\sigma^d} \varepsilon_R \phi_R * f \right\|_{L^p(\mathbb{R}^d \times \Omega^d; X)} \\
 &\leq (\alpha_{p, X}^+)^{d-1} (\beta_{p, X})^d \|f\|_{L^p(\mathbb{R}^d; X)}.
 \end{aligned}$$

It remains to estimate

$$\begin{aligned}
 \|m_R\|_{V^1(R; \mathcal{I})} &\leq \left\| \frac{m}{\widehat{\phi_R} \widehat{\phi_R}} \right\|_{\mathcal{V}^1(I; \mathcal{I})} \\
 &\leq \left\| \frac{1}{\widehat{\phi_R}} \right\|_{\mathcal{V}_\infty^1(R)}^2 \|m\|_{\mathcal{V}^1(R; \mathcal{I})} \leq (6^d)^2 \|m\|_{\mathcal{V}^1(R; \mathcal{I})}
 \end{aligned}$$

by Lemma 8.3.21 in the last step. Putting together all the estimates, observing a factor 2^d from the sum $\sum_{\sigma \in \{\pm\}^d}$, and estimating $2^d \cdot (6^d)^2 = (2 \cdot 6^2)^d < 100^d$, we obtain the asserted bound. \square

Corollary 8.3.22 (Lizorkin's multiplier theorem). *Let X and Y be UMD spaces with Pisier's contraction property and $p \in (1, \infty)$. Consider an operator-valued function $m \in C^d((\mathbb{R} \setminus \{0\})^d; \mathcal{L}(X, Y))$ such that*

$$M := \mathcal{R}_p(\{\xi^\beta \partial^\beta m(\xi) : \xi \in (\mathbb{R} \setminus \{0\})^d, \beta \in \{0, 1\}^d\}) < \infty.$$

Then m defines a Fourier multiplier from $L^p(\mathbb{R}^d; X)$ to $L^p(\mathbb{R}^d; Y)$ of norm

$$\begin{aligned} & \|T_m\|_{\mathcal{L}(L^p(\mathbb{R}^d; X), L^p(\mathbb{R}^d; Y))} \\ & \leq (200\beta_{p,X}\beta_{p,Y} \min\{\hbar_{p,X}, \hbar_{p,Y}\})^d (\alpha_{p,Y}^- \alpha_{p,X}^+)^{d-1} M. \end{aligned}$$

Proof. Let \mathcal{T} be the closure of the convex hull of $\{\xi^\beta \partial^\beta m(\xi) : \xi \in (\mathbb{R} \setminus \{0\})^d, \beta \in \{0, 1\}^d\}$, which is R -bounded with the same \mathcal{R}_p -bound M . Then

$$\begin{aligned} \|\mathbf{1}_R m\|_{\mathcal{V}^1(R; \mathcal{T})} & \leq \|\mathbf{1}_R m\|_{\mathcal{V}_\infty^1(R; \mathcal{T})} \\ & = \sum_{\beta \in \{0, 1\}^d} |R_\beta| \sup_{\xi \in R} \|\partial^\beta m(\xi)\|_{\mathcal{T}} \leq \sum_{\beta \in \{0, 1\}^d} |R_\beta| \sup_{\xi \in R} |\xi^{-\beta}| \\ & = \sum_{\beta \in \{0, 1\}^d} \prod_{i: \beta_i=1} |I_i| \sup_{\xi_i \in I_i} |\xi_i^{-1}| = \sum_{\beta \in \{0, 1\}^d} 1 = 2^d, \end{aligned}$$

where we used the basic property of the intervals $I_i \in \mathcal{I}$ that $\text{dist}(I_i, 0) = |I_i|$ in the penultimate step. Substituting this and $\mathcal{R}_p(\mathcal{T}) = M$ into the conclusion of Theorem 8.3.9, we get the claim of the corollary. \square

The higher-dimensional analogue of Theorem 8.3.12 is now immediate:

Corollary 8.3.23. *Let X and Y be UMD spaces with Pisier's contraction property. Let $p \in (1, \infty)$ and $\mathcal{T} \subseteq \mathcal{L}(X, Y)$ be an R -bounded set. Let $\mathcal{M}_{\mathcal{T}} \subseteq \mathcal{C}^d((\mathbb{R} \setminus \{0\})^d, \mathcal{L}(X, Y))$ be the collection of all multipliers that satisfy*

$$\{\xi^\beta \partial^\beta m(\xi) : \xi \in (\mathbb{R} \setminus \{0\})^d, \beta \in \{0, 1\}^d\} \subseteq \mathcal{T}.$$

Then $\{T_m : m \in \mathcal{M}_{\mathcal{T}}\} \subseteq \mathcal{L}(L^p(\mathbb{R}^d; X), L^p(\mathbb{R}^d; Y))$ is R -bounded, and in fact

$$\mathcal{R}_p(\{T_m : m \in \mathcal{M}_{\mathcal{T}}\}) \leq (200\alpha_{p,X}^+ \alpha_{p,Y}^- \beta_{p,X} \beta_{p,Y} \min\{\hbar_{p,X}, \hbar_{p,Y}\})^d \mathcal{R}_p(\mathcal{T}).$$

Proof. We adapt the proof of Theorem 8.3.12 with cosmetic modifications. By Proposition 8.1.17 it suffices to prove a uniform bound for the diagonal operators $(T_{m_n})_{n=1}^N$ acting from $\varepsilon_N^p(L^p(\mathbb{R}^d; X)) \simeq L^p(\mathbb{R}^d; \varepsilon_N^p(X))$ to $\varepsilon_N^p(L^p(\mathbb{R}^d; Y)) \simeq L^p(\mathbb{R}^d; \varepsilon_N^p(Y))$, where the identifications of the spaces are isometric. Under these identifications, we observe that $(T_{m_n})_{n=1}^N$ coincides with the Fourier multiplier $T_{\tilde{m}}$ with diagonal-operator-valued symbol $\tilde{m}(\xi) = (m_n(\xi))_{n=1}^N \in \mathcal{L}(\varepsilon_N^p(X), \varepsilon_N^p(Y))$.

Since $\xi^\beta \partial^\beta m_n(\xi) \in \mathcal{T}$ for each n , it follows that $\xi^\beta \partial^\beta \tilde{m}(\xi) \in \widetilde{\mathcal{T}}_N$, where $\widetilde{\mathcal{T}}_N$ is defined in Proposition 8.1.18. The aforementioned proposition guarantees that $\mathcal{R}_p(\widetilde{\mathcal{T}}_N) \leq \alpha_{p,X}^+ \alpha_{p,Y}^- \mathcal{R}_p(\mathcal{T})$. Thus the multiplier \tilde{m} is in the scope of Corollary 8.3.22 with X and Y replaced by $\varepsilon_N^p(X)$ and $\varepsilon_N^p(Y)$, and $M \leq \alpha_{p,X}^+ \alpha_{p,Y}^- \mathcal{R}_p(\mathcal{T})$. Since, by Fubini's theorem,

$$\beta_{p, \varepsilon_N^p(X)} = \beta_{p,X}, \quad \hbar_{p, \varepsilon_N^p(X)} = \hbar_{p,X}, \quad \alpha_{p, \varepsilon_N^p(X)}^\pm = \alpha_{p,X}^\pm$$

and likewise for Y in place of X , the claim of the theorem follows from Corollary 8.3.22 via the said identifications. \square

8.3.e Necessity of Pisier’s contraction property

While the one-dimensional Marcinkiewicz and Mihlin multiplier theorems (Theorem 8.3.9 and Corollary 8.3.11), as well the d -dimensional Mihlin Theorem 5.5.10 treated in Chapter 5, are valid in general UMD spaces, several variants above, namely Theorems 8.3.12 and 8.3.19 as well as Corollaries 8.3.22 and 8.3.23, were only formulated under the additional assumption of Pisier’s contraction property of the underlying spaces. The goal of this subsection is to justify the necessity of this assumption in the case that $X = Y$, already for scalar-valued multipliers.

Proposition 8.3.24. *Let $\mathcal{M} \subseteq C^1(\mathbb{R})$ be the collection of all multipliers such that $|m(\xi)|, |\xi m'(\xi)| \leq 1$. Let X be a Banach space and $p \in (1, \infty)$. If $\{T_m : m \in \mathcal{M}\}$ is R -bounded on $L^p(\mathbb{R}; X)$, then X has Pisier’s contraction property, and*

$$\alpha_{p,X} \leq 4M, \quad M := \mathcal{R}_p(\{T_m \in \mathcal{L}(L^p(\mathbb{R}; X)) : m \in \mathcal{M}\}).$$

Proof. By Proposition 8.1.17, the assumption means in particular that the operators $(T_{m_n})_{n=1}^N$ are uniformly bounded on $\varepsilon_N^p(L^p(\mathbb{R}; X))$ whenever $(m_n)_{n=1}^N$ belongs to \mathcal{M}^N , with norm at most M . Under the isometric identification $\varepsilon_N^p(L^p(\mathbb{R}; X)) \simeq L^p(\mathbb{R}; \varepsilon_N^p(X))$, the operator $(T_{m_n})_{n=1}^N$ becomes the Fourier multiplier $T_{\tilde{m}}$ where $\tilde{m}(\xi) = (m_n(\xi))_{n=1}^N$ is a diagonal operator on $\varepsilon_N^p(X)$. By the transference Theorem 5.7.1, we also have that the restriction to integer points, $(\tilde{m}(k))_{k \in \mathbb{Z}}$, defines a Fourier multiplier on $L^p(\mathbb{T}; \varepsilon_N^p(X))$ of at most the same norm, i.e., at most M again.

Let us write out the boundedness of this multiplier acting on a lacunary trigonometric polynomial $f(t) = \sum_{k=1}^N e_{2^k}(t)a_k$, where $e_k(t) := e^{i2\pi kt}$ and $a_k = \sum_{n=1}^N \varepsilon_n x_{kn} \in \varepsilon_N^p(X)$, where we have a free choice of vectors $x_{kn} \in X$. This reads as

$$\left\| \sum_{k,n=1}^N e_{2^k} \varepsilon_n m_n(2^k) x_{kn} \right\|_{L^p(\Omega \times \mathbb{T}; X)} \leq M \left\| \sum_{k,n=1}^N e_{2^k} \varepsilon_n x_{kn} \right\|_{L^p(\Omega \times \mathbb{T}; X)}.$$

Let $(\varepsilon'_k)_{k=1}^N$ be a Rademacher sequence on another probability space Ω' . Applying the previous bound to $\varepsilon'_k x_{kn}$ in place of x_{kn} and using that $(e_{2^k}(t)\varepsilon'_k)_{k=1}^N$ is equidistributed with $(\varepsilon'_k)_{k=1}^N$ for each $t \in \mathbb{T}$, it follows that

$$\left\| \sum_{k,n=1}^N \varepsilon'_k \varepsilon_n m_n(2^k) x_{kn} \right\|_{L^p(\Omega \times \Omega'; X)} \leq M \left\| \sum_{k,n=1}^N \varepsilon'_k \varepsilon_n x_{kn} \right\|_{L^p(\Omega \times \Omega'; X)}. \tag{8.10}$$

This resembles the defining condition of Pisier’s contraction property, except that we need to check that we can arrange arbitrary numbers α_{kn} of modulus at most one as the values of the multipliers $m_n(2^k)$.

This can be done as follows: Fix a function $\phi \in C^1(\mathbb{R})$, supported on $(\frac{1}{2}, 2)$ with $\|\phi\|_\infty = \phi(1) = 1$, $|\phi'(\xi)| \leq (1 + \delta)2$ on $[\frac{1}{2}, 1]$ and $|\phi'(\xi)| \leq (1 + \delta)$ on $[1, 2]$. We then set

$$\Phi_n(\xi) := \sum_{k=1}^N \alpha_{kn} \phi(2^{-k}\xi).$$

Clearly $\Phi_n(2^k) = \alpha_{kn}$. Let s be the unique integer such that $2^{-s}|\xi| \in [1, 2)$. Then

$$|\Phi_n(\xi)| \leq \sum_{k=1}^N |\phi(2^{-k}\xi)| \leq \sum_{k=s}^{s+1} 1 \leq 2,$$

and

$$|\xi \Phi'_n(\xi)| \leq \sum_{k=1}^N |2^{-k}\xi \phi'(2^{-k}\xi)| \leq \sum_{k=s}^{s+1} |2^{-k}\xi| |\phi'(2^{-k}\xi)| \leq 2 \cdot 2(1 + \delta).$$

So we deduce that $m_n = 4^{-1}(1 + \delta)^{-1}\Phi_n \in \mathcal{M}$ is a valid multiplier for (8.10), which then reads, in the limit $\delta \rightarrow 0$, as

$$\left\| \sum_{k,n=1}^N \varepsilon'_k \varepsilon_n \alpha_{kn} x_{kn} \right\|_{L^p(\Omega \times \Omega; X)} \leq 4M \left\| \sum_{k,n=1}^N \varepsilon'_k \varepsilon_n x_{kn} \right\|_{L^p(\Omega \times \Omega; X)}$$

for arbitrary scalars α_{kn} of modulus at most 1. This completes the proof. \square

Proposition 8.3.25. *Let $\mathcal{M} \subseteq C^2(\mathbb{R}^2)$ be the collection of all multipliers such that $|\xi^\beta \partial^\beta m(\xi)| \leq 1$ for all $\beta \in \{0, 1\}^2$. Let X be a Banach space and $p \in (1, \infty)$. If all T_m with $m \in \mathcal{M}$ are uniformly bounded on $L^p(\mathbb{R}^2; X)$, then X has Pisier's contraction property, and*

$$\alpha_{p,X} \leq 16M, \quad M := \sup_{m \in \mathcal{M}} (\|T_m\|_{\mathcal{L}(L^p(\mathbb{R}^2; X))}).$$

Proof. The proof is very similar to the previous one. By the transference Theorem 5.7.1 again, we find that each $(m(k))_{k \in \mathbb{Z}^2}$ defines a Fourier multiplier on $L^p(\mathbb{T}^2; X)$ of norm at most the same M . Written out for a bivariate lacunary trigonometric polynomial $f(s, t) = \sum_{j,k=1}^N x_{jk} e_{2^j}(s) e_{2^k}(t)$, this means that

$$\left\| \sum_{j,k=1}^N e_{2^j}^{(1)} e_{2^k}^{(2)} m(2^j, 2^k) x_{jk} \right\|_{L^p(\mathbb{T}^2; X)} \leq M \left\| \sum_{j,k=1}^N e_{2^j}^{(1)} e_{2^k}^{(2)} x_{jk} \right\|_{L^p(\mathbb{T}^2; X)},$$

where the superscripts (i) for $i = 1, 2$ indicate that these functions depend on the i th variable only. Applying this to $\varepsilon_j \varepsilon'_k x_{jk}$ in place of x_{jk} , and using that $(e_{2^j}(t_1) \varepsilon_j)_{j=1}^N$ and $(\varepsilon_j)_{j=1}^N$, as well as $(e_{2^k}(t_2) \varepsilon'_k)_{k=1}^N$ and $(\varepsilon'_k)_{k=1}^N$, are equidistributed for every $(t_1, t_2) \in \mathbb{T}^2$, we get

$$\left\| \sum_{j,k=1}^N \varepsilon_j \varepsilon'_k m(2^j, 2^k) x_{jk} \right\|_{L^p(\Omega; X)} \leq M \left\| \sum_{j,k=1}^N \varepsilon_j \varepsilon'_k x_{jk} \right\|_{L^p(\Omega; X)}, \quad (8.11)$$

and it only remains to check that we have sufficient freedom in the choice of values $m(2^j, 2^k)$.

To this end, we consider

$$\Phi(\xi) := \sum_{j,k=1}^N \alpha_{jk} \phi(2^{-j}\xi_1) \phi(2^{-k}\xi_2),$$

where ϕ is as in the proof of Proposition 8.3.24. If s, t are the unique integers such that $2^{-s}|\xi_1|, 2^{-t}|\xi_2| \in [1, 2)$, then

$$\begin{aligned} |\xi^\beta \partial^\beta \Phi(\xi)| &\leq \sum_{j=s}^{s+1} |2^{-j}\xi_1|^{\beta_1} |\phi^{(\beta_1)}(2^{-j}\xi_1)| \sum_{k=t}^{t+1} |2^{-k}\xi_2|^{\beta_2} |\phi^{(\beta_2)}(2^{-k}\xi_2)| \\ &\leq (4(1+\delta))^2, \end{aligned}$$

since both sums have the same form that was already estimated in the proof of Proposition 8.3.24. We conclude that $m = 4^{-2}(1+\delta)^{-2}\Phi$ is an admissible choice in (8.11), and hence, in the limit as $\delta \rightarrow 0$,

$$\left\| \sum_{j,k=1}^N \varepsilon_j \varepsilon'_k \alpha_{jk} x_{jk} \right\|_{L^p(\Omega; X)} \leq 4^2 M \left\| \sum_{j,k=1}^N \varepsilon_j \varepsilon'_k x_{jk} \right\|_{L^p(\Omega; X)},$$

for any scalars α_{jk} of absolute value at most one. □

8.4 Sources of R -boundedness in operator theory

In this section we present various general constructions of R -bounded families of operators on Banach spaces. In contrast to Section 8.2, which dealt with the specific context of L^p -spaces, we now work in abstract spaces.

8.4.a Duality and interpolation

It is often useful to know how the property of R -boundedness behaves under taking adjoints. We begin with the delicate problem of the R -boundedness of adjoint families. As it turns out, all goes well in K -convex spaces.

Proposition 8.4.1 (Duality). *Let $p \in (1, \infty)$ and $\frac{1}{p} + \frac{1}{p'} = 1$. Let \mathcal{T} be a family of operators in $\mathcal{L}(X, Y)$ and denote by $\mathcal{T}^* = \{T^* : T \in \mathcal{T}\}$ the adjoint family in $\mathcal{L}(Y^*, X^*)$.*

(1) *If X is K -convex and \mathcal{T} is R -bounded, then \mathcal{T}^* is R -bounded and we have*

$$\mathcal{R}_{p'}(\mathcal{T}^*) \leq K_{p,X} \mathcal{R}_p(\mathcal{T}).$$

(2) If Y is K -convex and \mathcal{T}^* is R -bounded, then \mathcal{T} is R -bounded and we have

$$\mathcal{R}_{p'}(\mathcal{T}) \leq K_{p',Y} \mathcal{R}_p(\mathcal{T}^*).$$

Proof. (1): Let $T_1^*, \dots, T_N^* \in \mathcal{T}^*$ and $y_1^*, \dots, y_N^* \in X^*$. Let $x_1, \dots, x_N \in X$ be such that $\left\| \sum_{n=1}^N \varepsilon_n x_n \right\|_{L^p(\Omega; X)} \leq 1$. Then, by Hölder's inequality we have

$$\begin{aligned} \left| \sum_{n=1}^N \langle x_n, T_n^* y_n^* \rangle \right| &= \left| \sum_{n=1}^N \langle T_n x_n, y_n^* \rangle \right| \\ &= \left| \mathbb{E} \left\langle \sum_{m=1}^N \varepsilon_m T_m x_m, \sum_{n=1}^N \varepsilon_n y_n^* \right\rangle \right| \\ &\leq \left\| \sum_{m=1}^N \varepsilon_m T_m x_m \right\|_{L^p(\Omega; Y)} \left\| \sum_{n=1}^N \varepsilon_n y_n^* \right\|_{L^{p'}(\Omega; Y^*)} \\ &\leq \mathcal{R}_p(\mathcal{T}) \left\| \sum_{n=1}^N \varepsilon_n y_n^* \right\|_{L^{p'}(\Omega; Y^*)}. \end{aligned}$$

Taking the supremum over all admissible finite sequence $(x_n)_{n=1}^N$, it follows from Corollary 7.4.6 that

$$\left\| \sum_{n=1}^N \varepsilon_n T_n^* y_n^* \right\|_{L^{p'}(\Omega; X^*)} \leq \mathcal{R}_p(\mathcal{T}) K_{p,X} \left\| \sum_{n=1}^N \varepsilon_n y_n^* \right\|_{L^{p'}(\Omega; Y^*)}.$$

(2): Since Y is K -convex, Y^* is K -convex (see Proposition 7.4.5) and $K_{p,Y^*} = K_{p',Y}$. Therefore (1) implies that the bi-adjoint family \mathcal{T}^{**} is R -bounded, with $\mathcal{R}_{p'}(\mathcal{T}^{**}) \leq K_{p',Y} \mathcal{R}_p(\mathcal{T}^*)$. Now (2) follows by taking restrictions. \square

The following example shows for general Banach spaces, the adjoint of an R -bounded family need not be R -bounded.

Example 8.4.2. Let X be any Banach space and consider the unit ball $\mathcal{T} = B_{X^*}$ as a uniformly bounded family in $\mathcal{L}(X, \mathbb{K})$. The adjoint family \mathcal{T}^* can be identified with B_{X^*} , viewing each $x^* \in B_{X^*}$ as a bounded operator from \mathbb{K} to X^* through the action $t \mapsto tx^*$. Inspecting the proof of Proposition 8.6.1 below we see that it contains the statement that *if B_{X^*} is R -bounded in $\mathcal{L}(\mathbb{K}, X^*)$, then X^* has type 2*. Taking $X = \ell^1$, we see that $\mathcal{T} = B_{\ell^\infty}$ is R -bounded in $\mathcal{L}(\ell^1, \mathbb{K})$ by Proposition 8.6.1, since ℓ^1 has cotype 2 (see Corollary 7.1.6) and \mathbb{K} has type 2. On the other hand, the adjoint family $\mathcal{T}^* = B_{\ell^\infty}$ is not R -bounded in $\mathcal{L}(\mathbb{K}, \ell^\infty)$ since ℓ^∞ does not have type 2 (see Corollary 7.1.10).

Next we show that for arbitrary Banach spaces X and Y , R -boundedness is preserved under taking bi-adjoints.

Proposition 8.4.3 (Bi-duality). *A family \mathcal{T} in $\mathcal{L}(X, Y)$ is R -bounded if and only if the bi-adjoint family $\mathcal{T}^{**} = \{T^{**} : T \in \mathcal{T}\}$ in $\mathcal{L}(X^{**}, Y^{**})$ is R -bounded, and in this case for all $1 \leq p < \infty$ we have*

$$\mathcal{R}_p(\mathcal{T}) = \mathcal{R}_p(\mathcal{T}^{**}).$$

Proof. We only need to prove the ‘only if’ part, the ‘if’ part being clear from the fact that X and Y are isometrically contained in their bi-duals and that, under these identifications, T^{**} restricts to T .

Given $T_1, \dots, T_N \in \mathcal{T}$, the operator $T : \varepsilon_N^p(X) \rightarrow \varepsilon_N^p(Y)$ defined by $T : (x_n)_{n=1}^N \mapsto (T_n x_n)_{n=1}^N$ is bounded of norm $\|T\| \leq \mathcal{R}_p(\mathcal{T})$ (see Proposition 8.1.17). Under the isometric isomorphism (see Proposition 6.3.4)

$$(\varepsilon_N^p(X))^{**} \simeq \varepsilon_N^p(X^{**}),$$

the operator $S : \varepsilon_N^p(X^{**}) \rightarrow \varepsilon_N^p(Y^{**})$ defined by $S : (x_n)_{n=1}^N \mapsto (T_n^{**} x_n)_{n=1}^N$ equals T^{**} , and therefore $\|S\| = \|T^{**}\| = \|T\| \leq \mathcal{R}_p(\mathcal{T})$. In view of Proposition 8.1.17, this implies the result. \square

Interpolation

R -boundedness interpolates under a K -convexity assumption:

Proposition 8.4.4. *Suppose (X_0, X_1) and (Y_0, Y_1) are interpolation couples, with X_0 and X_1 K -convex. Suppose further that \mathcal{T} is a family of linear operators from $X_0 + X_1$ to $Y_0 + Y_1$ which map X_0 into Y_0 and X_1 into Y_1 . If the restricted families $\mathcal{T}_0 \subseteq \mathcal{L}(X_0, Y_0)$ and $\mathcal{T}_1 \subseteq \mathcal{L}(X_1, Y_1)$ are R -bounded, then for all $\theta \in (0, 1)$ and $p, p_0, p_1 \in (1, \infty)$ such that $\frac{1}{p} = \frac{1-\theta}{p_0} + \frac{\theta}{p_1}$ the interpolated families $\mathcal{T}_\theta \subseteq \mathcal{L}([X_0, X_1]_\theta, [Y_0, Y_1]_\theta)$ and $\mathcal{T}_{\theta, p_0, p_1} \subseteq \mathcal{L}((X_0, X_1)_{\theta, p_0, p_1}, (Y_0, Y_1)_{\theta, p_0, p_1})$ are R -bounded, and we have*

$$\begin{aligned} \mathcal{R}_p(\mathcal{T}_\theta) &\leq K_{p_0, X_0}^{1-\theta} K_{p_1, X_1}^\theta (\mathcal{R}_{p_0}(\mathcal{T}_0))^{1-\theta} (\mathcal{R}_{p_1}(\mathcal{T}_1))^\theta, \\ \mathcal{R}_p(\mathcal{T}_{\theta, p_0, p_1}) &\leq K_{p_0, X_0}^{1-\theta} K_{p_1, X_1}^\theta (\mathcal{R}_{p_0}(\mathcal{T}_0))^{1-\theta} (\mathcal{R}_{p_1}(\mathcal{T}_1))^\theta. \end{aligned}$$

Recall that $X_{\theta, p_0, p_1} = (X_0, X_1)_{\theta, p}$ with equivalent norms (see Appendix C.3.14).

Proof. This is immediate from Theorem 7.4.16 and the description of R -bounded families in terms of bounded operators on the spaces $\varepsilon_N^p(X)$. For $x = (x_n)_{n=1}^N$ in $X_0 \cap X_1$ and $T = (T_n)_{n=1}^N$ in \mathcal{T} we have, using the notation of Proposition 8.1.17,

$$\begin{aligned} \|Tx\|_{\varepsilon_N^p([Y_0, Y_1]_\theta)} &\leq \|Tx\|_{[\varepsilon_N^{p_0}(Y_0), \varepsilon_N^{p_1}(Y_1)]_\theta} \\ &\leq \|T\|_{\varepsilon_N^{p_0}(X_0)}^{1-\theta} \|T\|_{\varepsilon_N^{p_1}(X_1)}^\theta \|x\|_{[\varepsilon_N^{p_0}(X_0), \varepsilon_N^{p_1}(X_1)]_\theta} \\ &\leq K_{p_0, X_0}^{1-\theta} K_{p_1, X_1}^\theta \|T\|_{\varepsilon_N^{p_0}(X_0)}^{1-\theta} \|T\|_{\varepsilon_N^{p_1}(X_1)}^\theta \|x\|_{\varepsilon_N^p(X_\theta)} \\ &\leq K_{p_0, X_0}^{1-\theta} K_{p_1, X_1}^\theta (\mathcal{R}_{p_0}(\mathcal{T}_0))^{1-\theta} (\mathcal{R}_{p_1}(\mathcal{T}_1))^\theta \|x\|_{\varepsilon_N^p(X_\theta)}. \end{aligned}$$

The proof for the real interpolation spaces runs along the same lines. \square

8.4.b Unconditionality

Although not every Banach space X has the triangular contraction property, the projection onto the diagonal is always bounded for X -valued double Rademacher sums. This provides a way to introduce additional randomness, a trick that will be used in the proof of the main result of this subsection, Proposition 8.4.6.

Lemma 8.4.5 (Diagonal projection). *Let X be a Banach space and let $(\varepsilon_n)_{n=1}^N$ and $(\varepsilon'_n)_{n=1}^N$ be Rademacher sequences on distinct probability spaces (Ω, \mathbb{P}) and (Ω', \mathbb{P}') , respectively. Then for all $1 \leq p < \infty$ and finite sequences $(x_{nk})_{n,k=1}^N$ in X ,*

$$\mathbb{E} \left\| \sum_{n=1}^N \varepsilon_n x_{nn} \right\|^p \leq \mathbb{E} \mathbb{E}' \left\| \sum_{n=1}^N \sum_{k=1}^N \varepsilon_n \varepsilon'_k x_{nk} \right\|^p.$$

Proof. By Jensen's inequality,

$$\mathbb{E} \left\| \sum_{n=1}^N \varepsilon_n x_{nn} \right\|^p = \mathbb{E} \left\| \mathbb{E}' \sum_{n,k=1}^N \varepsilon_n \overline{\varepsilon'_k} \varepsilon'_k x_{nk} \right\|^p \leq \mathbb{E} \mathbb{E}' \left\| \sum_{n,k=1}^N \varepsilon_n \overline{\varepsilon'_k} \varepsilon'_k x_{nk} \right\|^p.$$

Since for each $\omega' \in \Omega'$, $(\varepsilon_n \overline{\varepsilon'_k}(\omega'))_{n \geq 1}$ is identically distributed with $(\varepsilon_n)_{n \geq 1}$, it follows that

$$\mathbb{E}' \mathbb{E} \left\| \sum_{n,k=1}^N \varepsilon_n \overline{\varepsilon'_k} \varepsilon'_k x_{nk} \right\|^p = \mathbb{E}' \mathbb{E} \left\| \sum_{n,k=1}^N \varepsilon_n \varepsilon'_k x_{nk} \right\|^p,$$

and the result follows. \square

We now present an abstract method to derive R -boundedness from unconditionality.

Proposition 8.4.6. *Suppose X, Y, Z are Banach spaces and $(U_n)_{n \geq 1}$ and $(V_n)_{n \geq 1}$ are sequences of operators in $\mathcal{L}(X, Y)$ and $\mathcal{L}(Y, Z)$ satisfying the following conditions:*

- (i) *there exists a finite constant $M_U \geq 0$ such that*

$$\left(\mathbb{E} \left\| \sum_{n=1}^N \varepsilon_n U_n x \right\|^2 \right)^{1/2} \leq M_U \|x\|$$

for all $N \geq 1$ and $x \in X$;

- (ii) *there exists a finite constant $M_V \geq 0$ such that*

$$\left\| \sum_{n=1}^N \varepsilon_n V_n x \right\| \leq M_V \|x\|$$

for all scalars $|\varepsilon_1| = \dots = |\varepsilon_N| = 1$ and all $N \geq 1$ and $x \in X$.

Then the following assertions hold:

- (1) the set $\{U_n : n \geq 1\}$ is R -bounded, with R -bound at most M_U .
- (2) if Y has the triangular contraction property and $\mathcal{T} := \{T_n : n \geq 1\}$ is an R -bounded set in $\mathcal{L}(Y)$ with R -bound $\mathcal{R}(\mathcal{T})$, the family

$$\left\{ \sum_{n=1}^N V_n T_n U_n : N \geq 1 \right\}$$

is R -bounded, with R -bound at most $M_U M_V \Delta_Y \mathcal{R}(\mathcal{T})$.

- (3) if Y has Pisier's contraction property and \mathcal{T} is an R -bounded family in $\mathcal{L}(Y)$ with R -bound $\mathcal{R}(\mathcal{T})$, the family

$$\left\{ \sum_{n=1}^N V_n T_n U_n : N \geq 1, T_n \in \mathcal{T} (n = 1, \dots, N) \right\}$$

is R -bounded, with R -bound at most $M_U M_V \alpha_Y^- \alpha_Y^+ \mathcal{R}(\mathcal{T})$.

We will sometimes apply this result to families of operators indexed by \mathbb{Z} . The proposition can easily be adapted to this case; alternatively one can apply it, after re-indexing, to the indices $n \geq -N$ and then letting $N \rightarrow \infty$ (noting that R -boundedness passes on to the limit).

The proposition provides the abstract setting to prove R -boundedness results for the H^∞ -functional calculus in Theorem 10.3.4.

Proof. In the proof below, $(\varepsilon_n)_{n \geq 1}$, $(\varepsilon'_n)_{n \geq 1}$, $(\varepsilon''_{mn})_{n \geq 1}$ are Rademacher sequences on distinct probability spaces $\Omega, \Omega', \Omega''$.

- (1): For all finite sequences $x_1, \dots, x_N \in X$, by Lemma 8.4.5 we obtain

$$\begin{aligned} \mathbb{E} \left\| \sum_{n=1}^N \varepsilon_n U_n x_n \right\|^2 &\leq \mathbb{E} \mathbb{E}' \left\| \sum_{n=1}^N \sum_{k=1}^N \varepsilon_n \varepsilon'_k U_k x_n \right\|^2 \\ &= \mathbb{E} \mathbb{E}' \left\| \sum_{k=1}^N \varepsilon'_k U_k \sum_{n=1}^N \varepsilon_n x_n \right\|^2 \leq M_U \mathbb{E} \left\| \sum_{n=1}^N \varepsilon_n x_n \right\|^2. \end{aligned}$$

By Corollary 8.1.6, the R -boundedness of $(U_n)_{n \geq 1}$ follows from this.

- (2): We start with the preliminary estimate

$$\begin{aligned} \left\| \sum_{m=1}^N V_m y_m \right\|^2 &= \left\| \mathbb{E} \sum_{n=1}^N \bar{\varepsilon}_n V_n \sum_{m=1}^N \varepsilon_m y_m \right\|^2 \\ &\leq \mathbb{E} \left\| \sum_{n=1}^N \bar{\varepsilon}_n V_n \sum_{m=1}^N \varepsilon_m y_m \right\|^2 \leq M_V^2 \mathbb{E} \left\| \sum_{m=1}^N \varepsilon_m y_m \right\|^2, \end{aligned} \tag{8.12}$$

where we used the assumption on the V_m 's pointwise on Ω . Let us write $S_n := \sum_{m=1}^n V_m T_m U_m$ and pick $x_1, \dots, x_N \in X$. Applying (8.12) with $y_m = \sum_{n=1}^N \mathbf{1}_{m \leq n} \varepsilon'_n T_m U_m x_n$ gives

$$\begin{aligned}
\mathbb{E}' \left\| \sum_{n=1}^N \varepsilon'_n S_n x_n \right\|^2 &= \mathbb{E}' \left\| \sum_{m=1}^N V_m y_m \right\|^2 \\
&\leq M_V^2 \mathbb{E}' \mathbb{E} \left\| \sum_{n,m=1}^N \mathbf{1}_{m \leq n} \varepsilon_m \varepsilon'_n T_m U_m x_n \right\|^2 \\
&\leq M_V^2 \Delta_Y^2 \mathbb{E}' \mathbb{E} \left\| \sum_{n,m=1}^N \varepsilon_m \varepsilon'_n T_m U_m x_n \right\|^2;
\end{aligned}$$

in the last step we used the triangular contraction property. By the R -boundedness of \mathcal{T} ,

$$\begin{aligned}
\mathbb{E}' \mathbb{E} \left\| \sum_{n,m=1}^N \varepsilon_m \varepsilon'_n T_m U_m x_n \right\|^2 &= \mathbb{E}' \mathbb{E} \left\| \sum_{m=1}^N \varepsilon_m T_m U_m \sum_{n=1}^N \varepsilon'_n x_n \right\|^2 \\
&\leq \mathcal{R}(\mathcal{T})^2 \mathbb{E}' \mathbb{E} \left\| \sum_{m=1}^N \varepsilon_m U_m \sum_{n=1}^N \varepsilon'_n x_n \right\|^2 \\
&\leq \mathcal{R}(\mathcal{T})^2 M_U^2 \mathbb{E} \left\| \sum_{n=1}^N \varepsilon_n x_n \right\|^2;
\end{aligned}$$

in the last step we used the assumption on the U_m 's. By Corollary 8.1.6, this gives the R -boundedness of the operators S_n .

(3): For each $n \geq 1$ we choose operators $T_{mn} \in \mathcal{T}$, $m = 1, \dots, n$, and set $S_n := \sum_{m=1}^n V_m T_{mn} U_m$. Proceeding as in part (2), replacing T_m by T_{mn} we obtain

$$\mathbb{E}' \left\| \sum_{n=1}^N \varepsilon'_n S_n x_n \right\|^2 \leq M_V^2 \mathbb{E}' \mathbb{E} \left\| \sum_{m,n=1}^N \varepsilon_m \varepsilon'_n \mathbf{1}_{m \leq n} T_{mn} U_m x_n \right\|^2.$$

We now use the Pisier contraction property of Y to replace the double Rademacher sum by a single doubly indexed Rademacher sum (via Proposition 7.5.4), then the R -boundedness of \mathcal{T} , then once again Pisier's contraction property, and the Kahane contraction principle, to obtain

$$\begin{aligned}
\mathbb{E}' \mathbb{E} \left\| \sum_{m,n=1}^N \varepsilon_m \varepsilon'_n \mathbf{1}_{m \leq n} T_{mn} U_m x_n \right\|^2 &\leq (\alpha_{\bar{Y}})^2 \mathbb{E}'' \left\| \sum_{m,n=1}^N \varepsilon''_{mn} \mathbf{1}_{m \leq n} T_{mn} U_m x_n \right\|^2 \\
&\leq (\alpha_{\bar{Y}})^2 \mathcal{R}(\mathcal{T})^2 \mathbb{E}'' \left\| \sum_{m,n=1}^N \varepsilon''_{mn} U_m x_n \right\|^2 \\
&\leq (\alpha_{\bar{Y}})^2 (\alpha_{Y^\dagger})^2 \mathcal{R}(\mathcal{T})^2 \mathbb{E}' \mathbb{E} \left\| \sum_{m,n=1}^N \varepsilon_m \varepsilon'_n U_m x_n \right\|^2
\end{aligned}$$

$$\leq M_U^2 (\alpha_Y^-)^2 (\alpha_Y^+)^2 \mathcal{R}(\mathcal{T})^2 \mathbb{E}' \left\| \sum_{n=1}^N \varepsilon'_n x_n \right\|^2.$$

□

8.5 Integral means and smooth functions

We are interested in the R -boundedness of certain operator families associated with operator-valued functions. This covers, for instance, certain families of convolution operators with operator-valued kernels to be studied later on.

8.5.a Integral means I: elementary estimates

Throughout this section, (S, \mathcal{A}, μ) is a fixed measure space. The following terminology has already been introduced in the Notes of Chapter 1.

Definition 8.5.1. *An operator-valued function $f : S \rightarrow \mathcal{L}(X, Y)$ is called:*

- (i) *strongly μ -measurable, if for all $x \in X$ the Y -valued function $s \mapsto fx(s) := f(s)x$ is strongly μ -measurable;*
- (ii) *weakly μ -measurable, if for all $x \in X$ and $y^* \in Y^*$ the scalar-valued function $s \mapsto \langle fx, y^* \rangle(s) := \langle f(s), y^* \rangle$ is μ -measurable.*

One should be aware of the fact that there is a slight abuse of terminology here. Indeed, $\mathcal{L}(X, Y)$ is a Banach space in its own right, and therefore the term ‘strongly μ -measurable’ could also refer to the notion as introduced in Definition 1.1.14. It will always be clear from the context, however, that for operator-valued functions we use the notion of strong μ -measurability in the sense of Definition 8.5.1. For a fuller discussion we refer the reader to the Notes of Chapter 1.

Let $1 \leq r \leq \infty$ and $\frac{1}{r} + \frac{1}{r'} = 1$ and suppose a function $f : S \rightarrow \mathcal{L}(X, Y)$ is given such that

$$s \mapsto f(s)x \text{ belongs to } L^r(S; Y) \text{ for all } x \in X$$

(i.e., f belongs to the space $L_{\text{so}}^r(S; \mathcal{L}(X, Y))$ introduced in Definition 1.1.27. By the closed graph theorem, the mapping $x \mapsto fx$ is bounded from X to $L^r(S; Y)$, and therefore

$$\sup_{\|x\| \leq 1} \|fx\|_{L^r(S; Y)} < \infty.$$

For all $\phi \in L^{r'}(S)$ it is now possible to define a bounded operator $T_\phi^f \in \mathcal{L}(X, Y)$ by

$$T_\phi^f x := \int_S \phi(s) f(s)x \, d\mu(s), \quad x \in X. \quad (8.13)$$

Clearly,

$$\|T_\phi^f\| \leq \|\phi\|_{r'} \sup_{\|x\| \leq 1} \|fx\|_{L^r(S;Y)}.$$

In this section we will investigate the R -boundedness in $\mathcal{L}(X, Y)$ of the family

$$\mathcal{T}_{r'}^f := \{T_\phi^f : \|\phi\|_{r'} \leq 1\}. \quad (8.14)$$

As it turns out, it is useful to distinguish the cases $r' = 1$, $r' = \infty$, and $1 < r' < \infty$.

L^1 -integral means

We begin with the case $r' = 1$. By Propositions 8.1.21 and 8.1.22, the strongly closed absolutely convex hull of an R -bounded set is R -bounded. This may be used to show that R -boundedness is preserved by taking integral means:

Theorem 8.5.2 (L^1 -integral means). *Let $\mathcal{T} \subseteq \mathcal{L}(X, Y)$ be R -bounded. If $f : S \rightarrow \mathcal{L}(X, Y)$ is strongly μ -measurable and take values in \mathcal{T} , then the family \mathcal{T}_1^f is R -bounded and for all $1 \leq p < \infty$ we have*

$$\mathcal{R}_p(\mathcal{T}_1^f) \leq \mathcal{R}_p(\mathcal{T}).$$

The idea of the proof below is to write, for $\phi \in L^1(S)$ with $\|\phi\|_1 \leq 1$,

$$T_\phi^f = \int_S \|\phi\|_1 \frac{\phi(s)}{|\phi(s)|} f(s) \frac{|\phi(s)|}{\|\phi\|_1} d\mu(s).$$

Since $\frac{|\phi|}{\|\phi\|_1} d\mu$ is a probability measure and $\|\phi\|_1 \frac{\phi}{|\phi|} f$ takes values in $\text{abs conv } \mathcal{T}$, we may try to use the above observations. Some care is needed, however, due to the fact that f is not assumed to be strongly μ -measurable in the uniform operator topology, but only the functions fx . We therefore must implement the idea in the strong operator topology.

Proof. Let $T_\phi^f \in \mathcal{T}_1^f$ be arbitrary. By Propositions 8.1.21 and 8.1.22 it suffices to check that $T_\phi^f \in \overline{\text{abs conv}}^{\text{so}}(\mathcal{T})$. We may assume that $\phi \neq 0$ in $L^1(S)$. Fix $x_1, \dots, x_k \in X$ and note that

$$T_\phi^f x_j = \int_S g(s) x_j d\nu(s), \quad j = 1, \dots, k,$$

where $g(s) := \|\phi\|_1 \frac{\phi(s)}{|\phi(s)|} f(s)$ and $d\nu(s) = \frac{|\phi(s)|}{\|\phi\|_1} d\mu(s)$ satisfies $\nu(S) = 1$. Here we let $\frac{\phi(s)}{|\phi(s)|} = 0$ if $\phi(s) = 0$.

Clearly, the Y^k -valued function $s \mapsto (g(s)x_1, \dots, g(s)x_k)$ is ν -Bochner integrable and takes values in $\text{abs conv}((Tx_1, \dots, Tx_k) : T \in \mathcal{T})$. From Proposition 1.2.12 applied to Y^k we deduce that

$$(T_\phi^f x_1, \dots, T_\phi^f x_k) = \int_S (g(s)x_1, \dots, g(s)x_k) \, d\nu(s)$$

belongs to $\overline{\text{abs conv}}((Tx_1, \dots, Tx_k) : T \in \mathcal{T})$, where the closure is taken in Y^k . This means that for every $\varepsilon > 0$ we can find $T \in \text{abs conv}(\mathcal{T})$ such that

$$\|T_\phi^f x_j - Tx_j\| < \varepsilon, \quad j = 1, \dots, k.$$

Since the choices of $x_1, \dots, x_k \in X$ and $\varepsilon > 0$ were arbitrary, we have shown that every open set (in the strong operator topology) in $\mathcal{L}(X, Y)$ containing T_ϕ^f intersects $\text{abs conv}(\mathcal{T})$. It follows that $T_\phi^f \in \overline{\text{abs conv}}^{\text{so}}(\mathcal{T})$. \square

Example 8.5.3. Let $f : S \rightarrow \mathcal{L}(X, Y)$ be strongly measurable and take values in an R -bounded subset \mathcal{T} of $\mathcal{L}(X, Y)$. For $A \in \mathcal{A}$ with $0 < \mu(A) < \infty$ let $T_A \in \mathcal{L}(X, Y)$ be defined by

$$T_A x = \frac{1}{\mu(A)} \int_A f x \, d\mu, \quad x \in X.$$

Since $\phi := \frac{1}{\mu(A)} \mathbf{1}_A$ is L^1 -normalised, it follows from Theorem 8.5.2 that the family $\mathcal{S} := \{T_A : A \in \mathcal{A} \text{ with } 0 < \mu(A) < \infty\}$ is R -bounded and $R_p(\mathcal{S}) \leq R_p(\mathcal{T})$.

L^∞ -integral means

Recall that if $f : S \rightarrow \mathcal{L}(X, Y)$ has the property that $f x \in L^1(S; Y)$ for all $x \in X$, then for functions $\phi \in L^\infty(S)$ we may define the operator $T_\phi^f \in \mathcal{L}(X, Y)$ by (8.13), i.e.,

$$T_\phi^f x := \int_S \phi(s) f(s) x \, d\mu(s).$$

The next result proves shows that the family $\mathcal{T}_\infty^f = \{T_\phi^f : \|\phi\|_\infty \leq 1\}$ is always R -bounded.

Theorem 8.5.4 (L^∞ -integral means). *If $f : S \rightarrow \mathcal{L}(X, Y)$ is strongly μ -measurable and has the property that $f x \in L^1(S; Y)$ for all $x \in X$, then the family \mathcal{T}_∞^f is R -bounded and for all $1 \leq p < \infty$ we have*

$$\mathcal{R}_p(\mathcal{T}_\infty^f) \leq \kappa_{p,1} \sup_{\|x\| \leq 1} \int_S \|f x\| \, d\mu.$$

Under the stronger assumption that $s \mapsto \|f(s)\|$ is integrable, we have

$$\mathcal{R}_p(\mathcal{T}_\infty^f) \leq \int_S \|f\| \, d\mu.$$

Note that the second estimate does not feature the constant $\kappa_{p,1}$.

Remark 8.5.5. It may happen that the mapping $s \mapsto \|f(s)\|$ fails to be μ -measurable. The second part of the theorem remains true, however, if we replace the integrability of $\|f\|$ by the condition that there be a non-negative integrable function g such that $\|f\| \leq g$ almost everywhere; the inequality for $\mathcal{R}_p(\mathcal{T}_\infty^f)$ should then be replaced by $\mathcal{R}_p(\mathcal{T}_\infty^f) \leq \|g\|_1$. If X is separable this pathology does not arise: by considering a dense sequence $(x_n)_{n \geq 1}$ in the unit ball of X we see that $s \mapsto \|f(s)\| = \sup_{n \geq 1} \|f(s)x_n\|$ is μ -measurable.

Proof. Fix $\phi_1, \dots, \phi_N \in L^\infty(S)$ of norm at most one and $x_1, \dots, x_N \in X$. Using the Kahane contraction principle we estimate

$$\begin{aligned} \left\| \sum_{n=1}^N \varepsilon_n T_{\phi_n}^f x_n \right\|_{L^p(\Omega; Y)} &= \left\| \int_S \sum_{n=1}^N \varepsilon_n \phi_n(s) f(s) x_n \, d\mu(s) \right\|_{L^p(\Omega; Y)} \\ &\leq \int_S \left\| \sum_{n=1}^N \varepsilon_n \phi_n(s) f(s) x_n \right\|_{L^p(\Omega; Y)} \, d\mu(s) \\ &\leq \int_S \left\| \sum_{n=1}^N \varepsilon_n f(s) x_n \right\|_{L^p(\Omega; Y)} \, d\mu(s). \end{aligned}$$

Using the Kahane–Khintchine inequality and Fubini’s theorem, the right-hand side may be estimated as follows:

$$\begin{aligned} \int_S \left\| \sum_{n=1}^N \varepsilon_n f(s) x_n \right\|_{L^p(\Omega; Y)} \, d\mu(s) &\leq \kappa_{p,1} \mathbb{E} \int_S \left\| \sum_{n=1}^N \varepsilon_n f(s) x_n \right\| \, d\mu(s) \\ &\leq \kappa_{p,1} M \mathbb{E} \left\| \sum_{n=1}^N \varepsilon_n x_n \right\| \\ &\leq \kappa_{p,1} M \left\| \sum_{n=1}^N \varepsilon_n x_n \right\|_{L^p(\Omega; X)}, \end{aligned}$$

where M is the operator norm of the mapping $x \mapsto fx$. This gives the first inequality for $\mathcal{R}_p(\mathcal{T}^f)$.

If $\|f\|$ is integrable, we may alternatively estimate

$$\int_S \left\| \sum_{n=1}^N \varepsilon_n f(s) x_n \right\|_{L^p(\Omega; Y)} \, d\mu(s) \leq \int_S \|f\| \, d\mu \left\| \sum_{n=1}^N \varepsilon_n x_n \right\|_{L^p(\Omega; X)}.$$

□

Example 8.5.6 (R-boundedness of Laplace transforms I). In this example we assume that X and Y are complex Banach spaces.

Suppose that $f : \mathbb{R}_+ \rightarrow \mathcal{L}(X, Y)$ satisfies $fx \in L^1(\mathbb{R}_+; Y)$ for all $x \in X$. Define the Laplace transform of f by

$$\widehat{f}(\lambda)x := \int_0^\infty e^{-\lambda t} f(t)x \, dt, \quad x \in X, \lambda \in \mathbb{C}_+,$$

where $\mathbb{C}_+ = \{\lambda \in \mathbb{C} : \Re \lambda > 0\}$. Theorem 8.5.4 implies that the set $\{\widehat{f}(\lambda) : \Re \lambda > 0\}$ is R -bounded and

$$\mathcal{R}_p(\widehat{f}(\lambda) : \Re \lambda > 0) \leq \kappa_{p,1} \sup_{\|x\| \leq 1} \int_0^\infty \|f(t)x\| \, dt,$$

and the constant $\kappa_{p,1}$ can be omitted if $\|f(\cdot)\|$ is integrable. These results follow from the fact that for $\Re \lambda > 0$, $\widehat{f}(\lambda) = T_{\phi_\lambda}^f$ with $\phi_\lambda(t) = \exp(-\lambda t)$ satisfying $\|\phi_\lambda\|_\infty = 1$.

8.5.b The range of differentiable and holomorphic functions

As a useful consequence of Theorem 8.5.4 we show next that sufficiently smooth $\mathcal{L}(X, Y)$ -valued functions have R -bounded ranges. More refined versions of this result will be presented in the next subsection.

Let $-\infty \leq a < b \leq \infty$. We recall from Lemma 2.5.8 that $W^{1,1}(a, b; X)$ equals the space of all $f \in L^1(a, b; X)$ for which there exists a $g \in L^1(a, b; X)$ such that $t \mapsto f(t) - \int_a^t g(s) \, ds$ is constant for almost all $t \in (a, b)$. In this case g is unique and coincides with the weak and almost everywhere derivative of f . Moreover, after possibly redefining f on a set of measure zero, f is absolutely continuous and therefore the limits $f(a+) = \lim_{t \downarrow a} f(t)$ and $f(b-) = \lim_{t \uparrow b} f(t)$ exist.

Proposition 8.5.7 (Functions with integrable derivative). *Let $-\infty < a < b < \infty$. Let $f : (a, b) \rightarrow \mathcal{L}(X, Y)$ be such that each of the functions $t \mapsto f(t)x$, $x \in X$, is in $W^{1,1}(a, b; Y)$. Then the set*

$$\mathcal{T}_f := \{f(t) : t \in (a, b)\}$$

is R -bounded, there exists a constant $M \geq 0$ such that $\|f'x\|_{L^1(a, b; Y)} \leq M\|x\|$ for all $x \in X$, and for all $1 \leq p < \infty$ we have

$$\mathcal{R}_p(\mathcal{T}_f) \leq \|f(a+)\| + \kappa_{p,1} \sup_{\|x\| \leq 1} \int_a^b \|f'(t)x\| \, dt.$$

If $\int_a^b \|f'(t)\| \, dt < \infty$, then

$$\mathcal{R}_p(\mathcal{T}_f) \leq \|f(a+)\| + \int_a^b \|f'(t)\| \, dt.$$

For $a = -\infty$ and/or $b = \infty$, one can apply the theorem with $-\infty < a' < b' < \infty$ and pass to the limits $\lim_{a' \rightarrow -\infty}$ and/or $\lim_{b' \rightarrow \infty}$ in the above estimates.

Proof. Note that $f(a+) := \lim_{t \downarrow a} f(t)$ exists in the strong operator topology. Since

$$f(t)x = f(a+)x + \int_a^b \mathbf{1}_{(a,t)}(s)f'(s)x \, ds,$$

the result follows from Theorem 8.5.4. □

As a further illustration we have the following R -boundedness result for functions defined on a sector $\Sigma_\sigma = \{z \in \mathbb{C} \setminus \{0\} : |\arg z| < \sigma\}$ in the complex plane.

Proposition 8.5.8. *Let $0 < \sigma < \pi$. If $f : \Sigma_\sigma \rightarrow \mathcal{L}(X, Y)$ is a bounded holomorphic function, the following assertions hold:*

- (1) *if $\{f(\lambda) : \lambda \in \partial\Sigma_\nu, \lambda \neq 0\}$ is R -bounded, then $\{f(\lambda) : \lambda \in \Sigma_\nu\}$ is R -bounded, with the same R -bound;*
- (2) *If $a \in (1, \infty)$ and $0 < \nu < \sigma$, and $\{f(a^k z) : k \in \mathbb{Z}\}$ is R -bounded for each non-zero $z \in \partial\Sigma_\nu$, with uniform R -bounds, then for all $\mu \in (0, \nu)$ the set $\{f(\lambda) : \lambda \in \Sigma_\mu\}$ is R -bounded with*

$$\mathcal{R}(\{f(\lambda) : \lambda \in \Sigma_\mu\}) \leq 2a \left(1 + \frac{1}{\pi} \tan\left(\frac{\mu\pi}{\nu}\right)\right) \sup_{\substack{|\arg(z)|=\nu \\ z \neq 0}} \mathcal{R}(\{f(a^k z) : k \in \mathbb{Z}\}).$$

Proof. Replacing f by the function $\lambda \in \mathbb{C}_+ \mapsto f(\lambda^\alpha)$, $\alpha = 2\nu/\pi$, we may assume that $\nu = \frac{1}{2}\pi$. Assertion (1) now follows from Theorem 8.5.2 and Poisson's formula

$$f(u + iv) = \int_{-\infty}^{\infty} h(u, v - s)f(is) \, ds, \quad \alpha > 0,$$

with $h(u, v) = \frac{1}{\pi} \frac{u}{u^2 + v^2}$, noting that $\|h(u, \cdot)\|_1 = 1$.

Turning to the proof of (2), again we may assume that $\nu = \frac{1}{2}\pi$. Set $\beta := \tan(\mu)$, where now $\mu \in (0, \frac{1}{2}\pi)$. For any $t \in \mathbb{R}, t \neq 0$,

$$\mathcal{R}(\{f(ia^k t) : k \in \mathbb{Z}\}) \leq \sup_{\substack{|\arg(z)|=\frac{1}{2}\pi \\ z \neq 0}} \mathcal{R}(\{f(a^k z) : k \in \mathbb{Z}\}) =: C.$$

We will first prove the R -boundedness of the sets $\{f(z) : \arg(z) = \mu, z \neq 0\}$ and $\{f(z) : \arg(z) = -\mu, z \neq 0\}$. We begin with the former. Let $\lambda_1, \dots, \lambda_N \in \mathbb{C}$ satisfy $\arg \lambda_n = \mu$. We may write $\lambda_n = u_n + i\beta u_n$ with $u_n > 0$ and $\beta = \tan \mu$. Choose $k_n \in \mathbb{Z}$ so that $a^{k_n} < u_n \leq a^{k_n+1}$. Then

$$f(\lambda_n) = \int_{-\infty}^{\infty} f(it)h(u_n, \beta u_n - t) \, dt = \int_{-\infty}^{\infty} f(ia^{k_n} t)h(u_n, \beta u_n - a^{k_n} t)a^{k_n} \, dt.$$

Hence, for any finite sequence $x_1, \dots, x_N \in X$,

$$\begin{aligned}
 & \left\| \sum_{n=1}^N \varepsilon_n f(\lambda_n) x_n \right\|_{L^1(\Omega; X)} \\
 & \leq \int_{-\infty}^{\infty} \left\| \sum_{n=1}^N \varepsilon_n f(i a^{k_n} t) h(u_n, \beta u_n - a^{k_n} t) a^{k_n} x_n \right\|_{L^1(\Omega; X)} dt \\
 & \leq C \int_{-\infty}^{\infty} \left\| \sum_{n=1}^N \varepsilon_n h(u_n, \beta u_n - a^{k_n} t) a^{k_n} x_n \right\|_{L^1(\Omega; X)} dt \\
 & \leq C \int_{-\infty}^{\infty} \sup_{1 \leq n \leq N} |h(u_n, \beta u_n - a^{k_n} t)| a^{k_n} dt \left\| \sum_{n=1}^N \varepsilon_n x_n \right\|_{L^1(\Omega; X)},
 \end{aligned}$$

applying Kahane’s contraction principle in the last step. To estimate the integral, with $s_n := u_n a^{-k_n} \in (1, a]$ we have

$$|h(u_n, \beta u_n - a^{k_n} t)| a^{k_n} = \frac{1}{\pi} \frac{a^{k_n} u_n}{u_n^2 + (\beta u_n - a^{k_n} t)^2} = \frac{1}{\pi} \frac{s_n}{s_n^2 + (\beta s_n - t)^2}.$$

Since for $s \in (1, a]$, we have

$$\frac{s}{s^2 + (\beta s - t)^2} \leq \begin{cases} \frac{a}{1+t^2}, & t \in (-\infty, 0); \\ 1, & t \in [0, \beta a]; \\ \frac{a}{1+(\beta a - t)^2}, & t \in (\beta a, \infty), \end{cases}$$

it follows that

$$\int_{-\infty}^{\infty} \sup_{1 \leq n \leq N} |h(u_n, \beta u_n - a^{k_n} t)| a^{k_n} dt \leq \frac{1}{\pi} \left(\frac{a\pi}{2} + a\beta + \frac{a\pi}{2} \right) = a \left(1 + \frac{\beta}{\pi} \right).$$

Consequently $\{f(z) : \arg(z) = \mu z \neq 0\}$ is R -bounded, with R -bound at most $a(1 + \frac{\beta}{\pi})C$.

By symmetry, the same holds for $\{f(z) : \arg(z) = -\mu z \neq 0\}$. Taking unions, we find that $\{f(z) : |\arg(z)| = \mu\}$ is R -bounded, with R -bound at most $2a(1 + \frac{\beta}{\pi})C$. We now apply part (1) to complete the proof. \square

As a consequence we obtain the following result for the strip

$$\mathbb{S}_\theta := \{z \in \mathbb{C} : |\operatorname{Im}(z)| < \theta\}.$$

Corollary 8.5.9. *Let $\theta > 0$. If $f : \mathbb{S}_\theta \rightarrow \mathcal{L}(X, Y)$ is a bounded holomorphic function, then:*

- (1) *if $0 < \eta < \theta$ and $\{f(\lambda) : \lambda \in \partial\mathbb{S}_\eta, \lambda \neq 0\}$ is R -bounded, then $\{f(\lambda) : \lambda \in \mathbb{S}_\eta\}$ is R -bounded, with the same R -bound;*

(2) if $b \in (0, \infty)$ and $0 < \eta < \theta$, and if $\{f(kb + z) : k \in \mathbb{Z}\}$ is R -bounded for each non-zero $z \in \partial\mathbb{S}_\eta$, with uniform R -bounds, then for all $\beta \in (0, \eta)$ the set $\{f(\lambda) : \lambda \in \mathbb{S}_\beta\}$ is R -bounded, and

$$\mathcal{R}(\{f(\lambda) : \lambda \in \mathbb{S}_\beta\}) \leq 2e^b \left(1 + \frac{1}{\pi} \tan\left(\frac{\beta}{\eta} \frac{\pi}{2}\right)\right) \sup_{|\Im(z)|=\eta} \mathcal{R}(\{f(kb+z) : k \in \mathbb{Z}\}).$$

Proof. Both results follow from Proposition 8.5.8 applied to the function $z \mapsto f\left(\frac{\theta}{\sigma} \log(z)\right)$ defined on Σ_σ . □

We continue with a generalisation of part (1) of Proposition 8.5.8 and Corollary 8.5.9. By a *Jordan domain* we understand a connected open set in the complex plane whose boundary is the homeomorphic image of the unit circle.

Proposition 8.5.10. *Let $D \subsetneq \mathbb{C}$ be simply connected Jordan domain. Suppose $f : \overline{D} \rightarrow \mathcal{L}(X, Y)$ is strongly continuous, and assume that f is holomorphic on D . If $\{f(z) : z \in \partial D\}$ is R -bounded, then $\{f(z) : z \in \overline{D}\}$ is R -bounded as well, and both sets have the same R -bound.*

Proof. By the Riemann mapping theorem there exists a conformal mapping which maps D bijectively onto the open unit disc and which extends continuously to a homeomorphism from \overline{D} onto the closed unit disc. By the Poisson formula for the disc,

$$f(re^{i\theta}) = \frac{1}{2\pi} \int_0^{2\pi} P_r(\theta - \varphi) f(e^{i\varphi}) d\varphi,$$

where

$$P_r(\theta) = \frac{1 - r^2}{1 - 2r \cos \theta + r^2}.$$

Noting that $P_r(\theta) \geq 0$ and

$$\frac{1}{2\pi} \int_0^{2\pi} P_r(\theta) d\theta = 1, \quad r \in (0, 1),$$

the result follows from Theorem 8.5.2. □

Without *a priori* R -boundedness assumptions, operator-valued holomorphic functions are automatically R -bounded on compact sets:

Proposition 8.5.11. *Let D be a domain in \mathbb{C} and let $f : D \rightarrow \mathcal{L}(X, Y)$ be holomorphic. For every compact set $K \subseteq D$ the family $\mathcal{T}_K := \{f(z) : z \in K\}$ is R -bounded.*

Proof. For each $z_0 \in D$ the function f may be expressed as a power series in a neighbourhood of z_0 . More precisely,

$$f(z) = \sum_{n=0}^{\infty} \frac{1}{n!} f^{(n)}(z_0) (z - z_0)^n, \quad |z - z_0| < r(z_0),$$

where $r(z_0) > 0$ is the radius of convergence of the power series. Then, by Proposition 8.1.24,

$$\mathcal{R}(\{f(z) : |z - z_0| < \frac{1}{2}r(z_0)\}) \leq \sum_{n=0}^{\infty} \frac{1}{n!} \|f^{(n)}(z_0)\| (\frac{1}{2}r(z_0))^n < \infty.$$

Since K can be covered with finitely many balls of the form $\{z \in D : |z - z_j| < \frac{1}{2}r(z_j)\}$, the result follows. \square

8.5.c Integral means II: the effect of type and cotype

Let us fix a measure space (S, \mathcal{A}, μ) as well as an exponent $1 < r < \infty$, and consider a strongly measurable function $f : S \rightarrow \mathcal{L}(X, Y)$ (in the sense of Definition 8.5.1) such that

$$fx \in L^r(S; Y) \text{ for all } x \in X. \tag{8.15}$$

By the closed graph theorem there exists a constant $M \geq 0$ such that $\|fx\|_{L^r(S; Y)} \leq M\|x\|$ for all $x \in X$. Our aim is to prove, under suitable assumptions on X and/or Y , the R -boundedness of the family $\mathcal{T}_{r'}^f$ defined by (8.14), i.e.,

$$\mathcal{T}_{r'}^f := \{T_\phi^f : \|\phi\|_{r'} \leq 1\}.$$

Here T_ϕ^f is defined by (8.13),

$$T_\phi^f x := \int_S \phi(s) f(s) x \, d\mu(s).$$

We begin with the case where $s \mapsto \|f(s)\|$ belongs to $L^r(S)$; concerning the measurability of the function the same observations as in Remark 8.5.5 apply. Under this assumption, which is stronger than (8.15), we are able to exploit both the cotype of X and type of Y . Under the more general assumption (8.15), only the type properties of Y can be exploited, as we will see in Theorem 8.5.15.

Theorem 8.5.12. *Let X have cotype $q \in [2, \infty]$, Y type $p \in [1, 2]$, and suppose that $1 \leq r < \infty$ satisfies $\frac{1}{p} - \frac{1}{q} < \frac{1}{r}$. Let $f : S \rightarrow \mathcal{L}(X, Y)$ be a strongly μ -measurable function with the property that $s \mapsto \|f(s)\|$ belongs to $L^r(S)$. Then the family $\mathcal{T}_{r'}^f$ is R -bounded and*

$$\mathcal{R}(\mathcal{T}_{r'}^f) \lesssim \left(\int_S \|f\|^r \, d\mu \right)^{1/r},$$

with an implied constant depending only on X, Y, p, q and r .

Remark 8.5.13. In each of the following situations, Theorem 8.5.12 also holds in the limiting case $\frac{1}{r} = \frac{1}{p} - \frac{1}{q}$:

- (i) $p = 1, q = \infty, r = 1$. This follows from Theorem 8.5.4.
- (ii) $p = 2, q = 2, r = \infty$. This will follow from Proposition 8.6.1 and the uniform boundedness of \mathcal{T}_1^f .
- (iii) $p = 2, q = \infty, r = 2$. This will follow from Corollary 7.1.22 and the proof of Theorem 8.5.15.

In all three cases it is enough to assume that $fx \in L^r(S; Y)$ for all $x \in X$ (see Theorem 8.5.15 below) and we obtain the bound

$$\mathcal{R}(\mathcal{T}_{r'}^f) \lesssim \sup_{\|x\| \leq 1} \left(\int_S \|fx\|^r d\mu \right)^{1/r}.$$

- (iv) $p = 1, q = 2, r = 2$, and $s \mapsto \|f(s)\|$ belongs to $L^r(S)$. This follows from the last part of the proof of Theorem 8.5.12 and Corollary 7.1.22.

Proof of Theorem 8.5.12. Fix $x_1, \dots, x_N \in X$ and functions $\phi_1, \dots, \phi_N \in L^{r'}(S)$ such that $\sup_{1 \leq n \leq N} \|\phi_n\|_{L^{r'}(S)} \leq 1$.

First assume that $p \in (1, 2]$ and $q \in [2, \infty)$. Let $p_0 \in (1, p)$ and $q_0 \in (q, \infty)$ be such that $\frac{1}{r} = \frac{1}{p_0} - \frac{1}{q_0}$, so that $\frac{1}{r'} = \frac{1}{p_0'} + \frac{1}{q_0}$. Let

$$g_n := |\phi_n|^{r'/q_0}, \quad h_n := \frac{\phi_n}{|\phi_n|} |\phi_n|^{r'/p_0'}.$$

Then $\|g_n\|_{L^{q_0}(S)} \leq 1$, $\|h_n\|_{L^{p_0'}(S)} \leq 1$ and $\phi_n = g_n h_n$ for all $n = 1, \dots, N$. Choose $y_1^*, \dots, y_N^* \in Y^*$ such that $\mathbb{E} \left\| \sum_{n=1}^N \varepsilon_n y_n^* \right\|^{p_0'} \leq 1$. By Hölder's inequality and the identity $\frac{1}{p_0} = \frac{1}{r} + \frac{1}{q_0}$,

$$\begin{aligned} & \left| \mathbb{E} \left\langle \sum_{n=1}^N \varepsilon_n T_{\phi_n}^f x_n, \sum_{n=1}^N \varepsilon_n y_n^* \right\rangle \right| \\ &= \left| \mathbb{E} \int_S \left\langle f(s) \sum_{n=1}^N \varepsilon_n g_n(s) x_n, \sum_{n=1}^N \varepsilon_n h_n(s) y_n^* \right\rangle d\mu(s) \right| \\ &\leq \left(\mathbb{E} \left\| f \sum_{n=1}^N \varepsilon_n g_n x_n \right\|_{L^{p_0}(S; Y)}^{p_0} \right)^{1/p_0} \left(\mathbb{E} \left\| \sum_{n=1}^N \varepsilon_n h_n y_n^* \right\|_{L^{p_0'}(S; Y^*)}^{p_0'} \right)^{1/p_0'} \\ &\leq \|f\|_r \left(\mathbb{E} \left\| \sum_{n=1}^N \varepsilon_n g_n x_n \right\|_{L^{q_0}(S; X)}^{q_0} \right)^{1/q_0} \left(\mathbb{E} \left\| \sum_{n=1}^N \varepsilon_n h_n y_n^* \right\|_{L^{p_0'}(S; Y^*)}^{p_0'} \right)^{1/p_0'}, \end{aligned} \tag{8.16}$$

where $\|f\|_r = (\int_S \|f\|^r d\mu)^{1/r}$. Since X has cotype $q < q_0$ it follows from Theorem 7.2.6 that

$$\left(\mathbb{E} \left\| \sum_{n=1}^N \varepsilon_n g_n x_n \right\|_{L^{q_0}(S; X)}^{q_0} \right)^{1/q_0} \lesssim_{q_0, X} \left(\mathbb{E} \left\| \sum_{n=1}^N \varepsilon_n x_n \right\|^{q_0} \right)^{1/q_0}.$$

Also, Y has type p , so by Proposition 7.1.13, Y^* has cotype $p' < p_0'$ and it follows from Theorem 7.2.6 that

$$\left(\mathbb{E}\left\|\sum_{n=1}^N \varepsilon_n h_n y_n^*\right\|_{L^{p'_0}(S; Y^*)}^{p'_0}\right)^{1/p'_0} \lesssim_{p_0, Y} \left(\mathbb{E}\left\|\sum_{n=1}^N \varepsilon_n y_n^*\right\|^{p'_0}\right)^{1/p'_0} = 1.$$

Putting together these estimates, we conclude that

$$\left|\mathbb{E}\left\langle \sum_{n=1}^N \varepsilon_n T_{\phi_n}^f x_n, \sum_{n=1}^N \varepsilon_n y_n^* \right\rangle\right| \lesssim_{p_0, q_0, X, Y} \|f\|_r \left(\mathbb{E}\left\|\sum_{n=1}^N \varepsilon_n x_n\right\|^{q_0}\right)^{1/q_0}.$$

By assumption Y has non-trivial type, so Y is K -convex by Theorem 7.4.23. Taking the supremum over all $y_1^*, \dots, y_N^* \in Y^*$, by Corollary 7.4.6 we obtain

$$\left(\mathbb{E}\left\|\sum_{n=1}^N \varepsilon_n T_{\phi_n}^f x_n\right\|^{p_0}\right)^{1/p_0} \lesssim_{r, Y} \|f\|_r \left(\mathbb{E}\left\|\sum_{n=1}^N \varepsilon_n x_n\right\|^{p_0}\right)^{1/p_0}.$$

If $p > 1$ and $q = \infty$, one can easily adjust the above argument (take $g_n = \mathbf{1}$ for $n = 1, \dots, N$ in this case).

If $p = 1$ and $q < \infty$, then the duality argument does not work since Y has trivial type. However, one can argue more directly in this case. By assumption, we now have $r' > q$. By the triangle inequality, Hölder's inequality and Theorem 7.2.6,

$$\begin{aligned} \left\|\sum_{n=1}^N \varepsilon_n T_{\phi_n}^f x_n\right\|_{L^2(\Omega; Y)} &\leq \int_S \|f\| \left\|\sum_{n=1}^N \varepsilon_n \phi_n x_n\right\|_{L^2(\Omega; Y)} d\mu \\ &\leq \|f\|_r \left\|\sum_{n=1}^N \varepsilon_n \phi_n x_n\right\|_{L^{r'}(S; L^2(\Omega; Y))} \\ &\lesssim \|f\|_r \left\|\sum_{n=1}^N \varepsilon_n x_n\right\|_{L^2(\Omega; Y)}. \end{aligned}$$

□

Example 8.5.14 (R-boundedness of Laplace transforms II). Suppose that X has cotype $q \in [2, \infty]$ and Y has type $p \in [1, 2]$. Let $1 \leq r < \infty$ satisfy $\frac{1}{p} - \frac{1}{q} < \frac{1}{r}$. If $f : \mathbb{R}_+ \rightarrow \mathcal{L}(X, Y)$ is such that for all $x \in X$, $t \mapsto f(t)x$ is strongly measurable and $\|f(\cdot)\| \in L^r(\mathbb{R}_+)$, then the set $\{(\Re\lambda)^{1/r'} \widehat{f}(\lambda) : \Re\lambda > 0\}$ is R -bounded and

$$\mathcal{R}(\{(\Re\lambda)^{1/r'} \widehat{f}(\lambda) : \Re\lambda > 0\}) \lesssim \|f(\cdot)\|_r$$

with implied constant depending on X , Y , p , q , r . Indeed, this follows from Theorem 8.5.12 by proceeding as in Example 8.5.6, taking $\phi_\lambda(t) = (\Re\lambda)^{1/r'} \exp(-\lambda t)$.

In the cases when X has cotype 2 or Y has type 2, the following sharp result holds. If $f : \mathbb{R}_+ \rightarrow \mathcal{L}(X, Y)$ is strongly measurable and satisfies $\|f(\cdot)\| \in L^2(\mathbb{R}_+)$, the set

$$\{(\Re\lambda)^{1/2}\widehat{f}(\lambda) : \Re\lambda > 0\}$$

is R -bounded. This follows from Remark 8.5.13.

It is possible to replace the integrability condition on f by an integrability condition on the orbits fx , at the expense of not being able to exploit information about the cotype of X but only the type of Y .

Theorem 8.5.15. *Let $f : S \rightarrow \mathcal{L}(X, Y)$ be strongly μ -measurable.*

- (1) *If Y has type 2 and $fx \in L^2(S; Y)$ for all $x \in X$, then the family $\mathcal{T}_2^f = \{T_\phi^f : \|\phi\|_2 \leq 1\}$ is R -bounded and*

$$\mathcal{R}(\mathcal{T}_2^f) \lesssim \sup_{\|x\| \leq 1} \|fx\|_{L^2(S; Y)},$$

with an implied constant depending only on Y .

- (2) *If Y has type $p \in (1, 2)$ and $fx \in L^r(S; Y)$ for all $x \in X$, with $r \in (1, p)$, then the family $\mathcal{T}_{r'}^f = \{T_\phi^f : \|\phi\|_{r'} \leq 1\}$ is R -bounded and*

$$\mathcal{R}(\mathcal{T}_{r'}^f) \lesssim \sup_{\|x\| \leq 1} \|fx\|_{L^r(S; Y)},$$

with an implied constant depending only on Y , p , r .

Proof. We begin with the proof of (2). Fix $r \in (1, p)$. Then, arguing as in the proof of Theorem 8.5.12,

$$\begin{aligned} & \left| \mathbb{E} \left\langle \sum_{n=1}^N \varepsilon_n T_{\phi_n}^f x_n, \sum_{n=1}^N \varepsilon_n y_n^* \right\rangle \right| \\ &= \left| \int_S \sum_{n=1}^N \langle \phi_n(s) f(s) x_n, y_n^* \rangle d\mu(s) \right| \\ &\leq \left(\mathbb{E} \left\| f \sum_{n=1}^N \varepsilon_n x_n \right\|_{L^r(S; Y)}^r \right)^{1/r} \left(\mathbb{E} \left\| \sum_{n=1}^N \varepsilon_n \phi_n y_n^* \right\|_{L^{r'}(S; Y^*)}^{r'} \right)^{1/r'} \\ &\leq M \left(\mathbb{E} \left\| \sum_{n=1}^N \varepsilon_n x_n \right\|_{L^r(S; X)}^r \right)^{1/r} \left(\mathbb{E} \left\| \sum_{n=1}^N \varepsilon_n \phi_n y_n^* \right\|_{L^{r'}(S; Y^*)}^{r'} \right)^{1/r'}, \end{aligned}$$

where $M = \sup_{\|x\| \leq 1} \|fx\|_{L^r(S; Y)}$. Since Y^* has cotype p' , from Theorem 7.2.6 we infer that

$$\left(\mathbb{E} \left\| \sum_{n=1}^N \varepsilon_n \phi_n y_n^* \right\|_{L^{r'}(S; Y^*)}^{r'} \right)^{1/r'} \lesssim \left(\mathbb{E} \left\| \sum_{n=1}^N \varepsilon_n y_n^* \right\|_{Y^*}^{r'} \right)^{1/r'}.$$

As in the proof of Theorem 8.5.12, combining these estimates and using that Y is K -convex, we obtain that

$$\left(\mathbb{E}\left\|\sum_{n=1}^N \varepsilon_n T_{\phi_n}^f x_n\right\|^r\right)^{1/r} \lesssim M\left(\mathbb{E}\left\|\sum_{n=1}^N \varepsilon_n x_n\right\|^r\right)^{1/r}.$$

This completes the proof of (2). For the proof of (1) we may replace p and r by 2 in the above argument and invoke Corollary 7.1.22 instead of Theorem 7.2.6. \square

The final result in this section shows how one can use Theorem 7.2.6 to obtain a version of Theorem 8.5.12 with sharp exponents.

For two measurable scalar-valued functions ϕ and ψ we will write

$$\phi \prec \psi \iff \forall t > 0 : \mu(\{|\phi| > t\}) \leq \mu(\{|\psi| > t\}).$$

For $\psi \in L^1(S) + L^\infty(S)$ let

$$L_\psi(S) = \{\phi \in L^1(S) + L^\infty(S) : \phi \prec \psi\}.$$

Proposition 8.5.16. *Let X have cotype $q \in [2, \infty]$ and Y type $p \in [1, 2]$, and let $\frac{1}{r} = \frac{1}{p} - \frac{1}{q}$ and $\frac{1}{r} + \frac{1}{r'} = 1$. Let $\sigma = \min\{\frac{r'}{q}, \frac{r'}{p}\}$. Suppose $f : S \rightarrow \mathcal{L}(X, Y)$ is strongly μ -measurable and satisfies $\|f(\cdot)\| \in L^r(S)$. Then, for any $\psi \in L^{r', \sigma}(S)$,*

$$\mathcal{R}(\{T_\phi^f \in \mathcal{L}(X, Y) : \phi \in L_\psi(S)\}) \lesssim \left(\int_S \|f\|^r d\mu\right)^{1/r} \|\psi\|_{L^{r', \sigma}(S)},$$

with implied constant independent of f and ψ .

Since each $\phi \in L_\psi(S)$ is also in $L^{r'}(S)$ (see (F.3) and Lemma F.3.5), the operators $T_\phi^f \in \mathcal{L}(X, Y)$ are well defined. In the limiting cases $p \in \{1, 2\}$ and $q \in \{2, \infty\}$, Remark 8.5.13 gives a stronger result.

Proof. The proof follows the lines of Theorem 8.5.12. Without loss of generality we may assume that $\|\psi\|_{L^{r, \sigma}(S)} = 1$. Let $\phi_1, \dots, \phi_N \in L_{\phi_0}(S)$ and $x_1, \dots, x_N \in X$ be arbitrary and fixed.

First assume that $p \in (1, 2]$ and $q \in [2, \infty)$. Let

$$g_n := |\phi_n|^{r'/q}, \quad h_n := \frac{\phi_n}{|\phi_n|} |\phi_n|^{r'/p'}$$

for $n = 1, \dots, N$, so that $\phi_n = g_n h_n$. Choose $y_1^*, \dots, y_N^* \in Y^*$ such that $\mathbb{E}\|\sum_{n=1}^N \varepsilon_n y_n^*\|^{p'} \leq 1$. Following the lines of (8.16) and using the identity $\frac{1}{p} = \frac{1}{r} + \frac{1}{q}$, we obtain the estimate

$$\begin{aligned} & \left| \mathbb{E} \left\langle \sum_{n=1}^N \varepsilon_n T_{\phi_n}^f x_n, \sum_{n=1}^N \varepsilon_n y_n^* \right\rangle \right| \\ & \leq \|f\|_r \left(\mathbb{E} \left\| \sum_{n=1}^N \varepsilon_n g_n x_n \right\|_{L^q(S; X)}^q \right)^{1/r} \left(\mathbb{E} \left\| \sum_{n=1}^N \varepsilon_n h_n y_n^* \right\|_{L^{p'}(S; Y^*)}^{p'} \right)^{1/p'}, \end{aligned}$$

where $\|f\|_r = (\int_S \|f\|^r d\mu)^{1/r}$ as before. Since X has cotype q by Theorem 7.2.6 and the assumption $\phi_n \prec \psi$,

$$\begin{aligned} & \left(\mathbb{E} \left\| \sum_{n=1}^N \varepsilon_n g_n x_n \right\|_{L^q(S; X)}^q \right)^{1/q} \\ & \lesssim_{q, X} \left(\int_0^\infty \mu(|\psi| > t^{q/r'})^{1/q} dt \right) \left(\mathbb{E} \left\| \sum_{n=1}^N \varepsilon_n x_n \right\|^q \right)^{1/q}. \end{aligned}$$

It follows from (F.4) and the inclusion $L^{r', \sigma}(S) \hookrightarrow L^{r', r'/q}(S)$ (see Lemma F.3.5) that

$$\begin{aligned} \int_0^\infty \mu(|\psi| > t^{q/r'})^{1/q} dt &= \frac{r'}{q} \int_0^\infty \mu(|\psi| > t)^{1/q} t^{r'/q} \frac{dt}{t} \\ &= \frac{r'}{q} (r')^{-r'/q} \|\psi\|_{L^{r', r'/q}(S)}^{r'/q} \\ &\leq C_{q, r} \|\psi\|_{L^{r', \sigma}(S)}^{r'/q} \leq C_{q, r, \sigma}. \end{aligned}$$

Since Y has type p it follows that Y^* has cotype p' (see Proposition 7.1.13), and therefore it follows from Theorem 7.2.6 that

$$\begin{aligned} & \left(\mathbb{E} \left\| \sum_{n=1}^N \varepsilon_n h_n y_n^* \right\|_{L^{p'}(S; Y^*)}^{p'} \right)^{1/p'} \\ & \lesssim_{p, Y} \left(\int_0^\infty \mu(|\psi| > t^{p'/r'})^{1/p'} dt \right) \left(\mathbb{E} \left\| \sum_{n=1}^N \varepsilon_n y_n^* \right\|^{p'} \right)^{1/p'}. \end{aligned}$$

As before, since $L^{r', \sigma}(S) \hookrightarrow L^{r', r'/p'}(S)$ we have

$$\int_0^\infty \mu(|\psi| > t^{p'/r'})^{1/p'} dt \leq C_{p, r, \sigma}.$$

The result can now be finished using the same duality argument as in Theorem 8.5.12.

If $p > 1$ and $q = \infty$ one can easily adjust the above argument (take $g_n = \mathbf{1}$ in this case). If $p = 1$ and $q < \infty$, then one can argue as in Theorem 8.5.12, but instead of Theorem 7.2.6 one has to apply Theorem 7.2.6. If $p = 1$ and $q = \infty$ the result follows from Theorem 8.5.12. \square

In the same way one can prove the following version for the strong operator topology:

Proposition 8.5.17. *If Y has type $p \in (1, 2]$, $fx \in L^r(S; Y)$ for all $x \in X$, and $\psi \in L^{p', 1}(S)$, then the family $\mathcal{T}^f = \{T_\phi^f \in \mathcal{L}(X, Y) : \phi \in L_\psi(S)\}$ is R -bounded and*

$$\mathcal{R}(\mathcal{T}^f) \lesssim \|\psi\|_{L^{p', 1}(S)} \sup_{\|x\| \leq 1} \|f\|_{L^r(S; Y)},$$

with an implied constant independent of ψ and f .

8.5.d The range of functions of fractional smoothness

By Proposition 8.5.7, operator-valued functions with integrable derivatives have R -bounded ranges. It is natural to ask whether this result is the best possible. As an application of Theorem 8.5.12 we show next that, in the presence of non-trivial type p and/or finite cotype q , R -boundedness can be obtained under weaker regularity assumptions, the amount of regularity needed being measured by the exponent $\frac{1}{p} - \frac{1}{q}$. In the limiting case $p = q = 2$ (which, by Kwapień's theorem, corresponds to the Hilbert space case), no regularity is needed at all: uniform boundedness of the range suffices.

Let $D \subseteq \mathbb{R}^d$ be a domain and let $p \in [1, \infty)$ and $0 < s < 1$. We recall from Section 2.5.d that the Sobolev space $W^{s,p}(D; X)$ is defined as the space of all $f \in L^p(D; X)$ for which

$$[f]_{W^{s,p}(D;X)} = \left(\int_D \int_D \frac{\|f(u) - f(v)\|^p}{|u - v|^{sp+d}} du dv \right)^{1/p}$$

is finite. Endowed with the norm

$$\|f\|_{W^{s,p}(D;X)} = \|f\|_{L^p(D;X)} + [f]_{W^{s,p}(D;X)},$$

this is a Banach space.

Definition 8.5.18. A domain $D \subseteq \mathbb{R}^d$ is called *plump*, with parameters $R > 0$ and $\delta \in (0, 1]$, if for all $x \in D$ and $r \in (0, R]$ there exists a $z \in D$ such that

$$B(z, \delta r) \subseteq B(x, r) \cap D.$$

In such domains, we have a good integral representation of Sobolev functions:

Proposition 8.5.19. Let $D \subseteq \mathbb{R}^d$ be plump with parameters $R > 0$ and $\delta \in (0, 1]$. Then for all $x \in D$ there exist measurable functions $G^x : D \rightarrow \mathbb{R}$ and $H^x : D \times D \rightarrow \mathbb{R}$ such that for all $p \in (d, \infty)$ and $s > d/p$,

$$\begin{aligned} \|u \mapsto G^x(u)\|_{L^{p'}(D)} &\leq C_{d,p}(R\delta)^{-d/p}, \\ \left\| (u, v) \mapsto |u - v|^{s+d/p} H^x(u, v) \right\|_{L^{p'}(D \times D)} &\leq C_{d,p,s} \delta^{-2d/p} R^{s-d/p}, \end{aligned}$$

and such that for any Banach space X , any $f \in W^{s,p}(D; X)$, and any Lebesgue point x of f we have

$$f(x) = \int_D G^x(u) f(u) du + \iint_{D \times D} H^x(u, v) (f(u) - f(v)) du dv.$$

Proof. Let $B := B(0, 1) \subseteq \mathbb{R}^d$ be the unit ball, and $\phi := |B|^{-1} \mathbf{1}_B$ its normalised indicator function.

Given $x \in D$, we fix sequence of points $(x_k)_{k=0}^\infty$, guaranteed by plumpness of D , such that $B(x_k, \delta 2^{-k} R) \subseteq B(x, 2^{-k} R) \cap D$ for every $k \geq 0$. If x is a Lebesgue point of f , it follows that

$$f(x) = \lim_{k \rightarrow \infty} \int_D \phi\left(\frac{y - x_k}{\delta 2^{-k} R}\right) \frac{f(y)}{(\delta 2^{-k} R)^d} dy,$$

where we note that there is no difference between integrating over D or \mathbb{R}^d , due to the support of ϕ . Defining

$$G^x(y) := \phi\left(\frac{y - x_0}{\delta R}\right) \frac{1}{(\delta R)^d}, \quad \|G^x\|_{L^{p'}(D)} = (\delta R)^{-d/p} \|\phi\|_{p'} = c_{d,p} (\delta R)^{-d/p},$$

we can write a telescopic expansion

$$\begin{aligned} f(x) - \int_D G^x(y) f(y) dy &= \sum_{k=0}^{\infty} \left(\int_D \phi\left(\frac{y - x_{k+1}}{\delta 2^{-(k+1)} R}\right) \frac{f(y)}{(\delta 2^{-(k+1)} R)^d} dy - \int_D \phi\left(\frac{y - x_k}{\delta 2^{-k} R}\right) \frac{f(y)}{(\delta 2^{-k} R)^d} dy \right) \\ &= \sum_{k=0}^{\infty} \iint_{D \times D} \phi\left(\frac{u - x_{k+1}}{\delta 2^{-(k+1)} R}\right) \phi\left(\frac{v - x_k}{\delta 2^{-k} R}\right) \frac{(f(u) - f(v))}{(\delta 2^{-(k+1)} R)^d (\delta 2^{-k} R)^d} du dv \\ &=: \sum_{k=0}^{\infty} \iint_{D \times D} H_k^x(u, v) (f(u) - f(v)) du dv. \end{aligned}$$

Note that

$$\begin{aligned} \text{supp } H_k^x &= B(x_{k+1}, \delta 2^{-(k+1)} R) \times B(x_k, \delta 2^{-k} R) \\ &\subseteq B(x, 2^{-(k+1)} R) \times B(x, 2^{-k} R), \end{aligned}$$

and hence $|u - v| \leq |u - x| + |v - x| \leq \frac{3}{2} 2^{-k} R$ for $(u, v) \in \text{supp } H_k^x$. Thus

$$\begin{aligned} \|(u, v) \mapsto |u - v|^{s+d/p} H_k^x(u, v)\|_{L^{p'}(D \times D)} &\leq c_{d,p,s} (2^{-k} R)^{s+d/p} \|H_k^x\|_{L^{p'}(D \times D)} \\ &= c_{d,p,s} (2^{-k} R)^{s+d/p} (\delta 2^{-k} R)^{-2d/p} = c_{d,p,s} \delta^{-2d/p} (2^{-k} R)^{s-d/p}. \end{aligned}$$

Defining

$$H^x(u, v) := \sum_{k=0}^{\infty} H_k^x(u, v),$$

we have

$$\begin{aligned} \|(u, v) \mapsto |u - v|^{s+d/p} H^x(u, v)\|_{L^{p'}(D \times D)} &\leq \sum_{k=0}^{\infty} \|(u, v) \mapsto |u - v|^{s+d/p} H_k^x(u, v)\|_{L^{p'}(D \times D)} \\ &\leq c_{d,p,s} \delta^{-2d/p} R^{s-d/p}, \end{aligned}$$

where convergence is guaranteed by $s > d/p$. Since the function $(u, v) \mapsto |u - v|^{-s-d/p} (f(u) - f(v))$ belongs to $L^p(D \times D)$, we obtain the convergence of the integral representation

$$f(x) = \int_D G^x(y)f(y) \, dy + \iint_{D \times D} H^x(u, v)(f(u) - f(v)) \, du \, dv$$

as claimed. □

A classical corollary of Proposition 8.5.19 is the following:

Corollary 8.5.20 (Sobolev embedding theorem). *Let $D \subseteq \mathbb{R}^d$ be plump with parameters $R > 0$ and $\delta \in (0, 1]$. Then for all $p \in (d, \infty)$ and $s > d/p$, and every Banach space X , we have a continuous embedding*

$$W^{s,p}(D; X) \hookrightarrow L^\infty(D; X).$$

Proof. From the proven representation, we deduce by Hölder’s inequality that

$$\begin{aligned} \|f(x)\| &\leq \|G^x\|_{L^{p'}(D)} \|f\|_{L^p(D; X)} \\ &\quad + \|(u, v) \mapsto |u - v|^{s+d/p} H^x(u, v)\|_{L^{p'}(D \times D)} [f]_{W^{s,p}(D; X)} \\ &\leq c_{d,s,p} ((\delta R)^{-d/p} + \delta^{-2d/p} R^{s-d/p}) \|f\|_{W^{s,p}(D; X)}. \end{aligned}$$

This is valid at every Lebesgue point of f , and thereby almost everywhere. □

By an elaboration of the same argument, we have a strengthening of this result involving R -boundedness.

Theorem 8.5.21. *Let X and Y be Banach space such that X has cotype $q \in [2, \infty]$ and Y has type $p \in [1, 2]$, and let $\frac{1}{p} - \frac{1}{q} < \frac{1}{r} < s < 1$. Let $D \subseteq \mathbb{R}^d$ be a plump domain with parameters $\delta \in (0, 1]$ and $R > 0$. Then every $f \in W^{s,r}(D; \mathcal{L}(X, Y))$ has R -bounded range, and*

$$\mathcal{R}(\{f(t) : t \text{ Lebesgue point of } f\}) \lesssim \|f\|_{W^{s,r}(D; \mathcal{L}(X, Y))},$$

where the implied constant depends on the various parameters in the statement, but is independent of the function f .

On a bounded domain D it is immediate to check that $C^\alpha(D; \mathcal{L}(X, Y)) \hookrightarrow W^{s,r}(D; \mathcal{L}(X, Y))$ for $\alpha > s$, so we also obtain sufficient conditions for an R -bounded range of Hölder continuous functions.

Proof. Using the representation given in Proposition 8.5.19, recalling the notation

$$\mathcal{F}_{r'}^f := \left\{ x \mapsto \int_D \phi(t) f(t) x \, dt : \|\phi\|_{r'} \leq 1 \right\}$$

introduced before Theorem 8.5.12, and denoting

$$F(u, v) := \frac{f(u) - f(v)}{|u - v|^{s+d/r}}, \quad \|F\|_{L^r(D \times D; \mathcal{L}(X, Y))} = [f]_{W^{s,r}(D; \mathcal{L}(X, Y))},$$

we find that

$$\begin{aligned}
f(t) &= \int_D G^t(u) f(u) \, du + \iint_{D \times D} |u-v|^{s+d/r} H^t(u,v) F(u,v) \, du \, dv \\
&\in \|G^t\|_{L^{r'}(D)} \mathcal{T}_{r'}^f + \|(u,v) \mapsto |u-v|^{s+d/r} H^t(u,v)\|_{L^{r'}(D \times D)} \mathcal{T}_{r'}^F \quad (8.17) \\
&\subseteq C_{d,r} (R\delta)^{-d/r} \mathcal{T}_{r'}^f + C_{d,s,r} \delta^{-2d/r} R^{s-d/r} \mathcal{T}_{r'}^F.
\end{aligned}$$

By Theorem 8.5.12,

$$\mathcal{R}(\mathcal{T}_{r'}^f) \lesssim \|f\|_{L^r(D; \mathcal{L}(X,Y))}, \quad \mathcal{R}(\mathcal{T}_{r'}^F) \lesssim \|f\|_{L^r(D \times D; \mathcal{L}(X,Y))}.$$

Combining the estimates, we obtain the claim of the theorem. \square

Remark 8.5.22. Step (8.17) above implies the slightly more precise bound

$$\begin{aligned}
&\mathcal{R}(\{f(t) : t \text{ Lebesgue point of } f\}) \\
&\lesssim C_{d,r} (R\delta)^{-d/r} \|f\|_{L^r(D; \mathcal{L}(X,Y))} + C_{d,s,r} \delta^{-2d/r} R^{s-d/r} [f]_{W^{s,r}(D; \mathcal{L}(X,Y))}.
\end{aligned}$$

In the case of a special domain (such as \mathbb{R}^d or a half space) that is plump with some $\delta \in (0, 1]$ and every $R > 0$, we can optimise over $R > 0$ to get

$$\begin{aligned}
&\mathcal{R}(\{f(t) : t \text{ Lebesgue point of } f\}) \\
&\lesssim C_{d,r,s,\delta} \|f\|_{L^r(D; \mathcal{L}(X,Y))}^{1-d/rs} [f]_{W^{s,r}(D; \mathcal{L}(X,Y))}^{d/rs}.
\end{aligned}$$

8.6 Coincidence of R -boundedness with other notions

We have already seen in Theorem 8.1.3 that R -boundedness in $\mathcal{L}(X, Y)$ agrees with uniform boundedness if X has cotype 2 and Y has type 2, and with γ -boundedness if X has finite cotype. The aim of this section is to show that both these coincidences actually characterise the respective properties of the Banach spaces, and hence cannot be extended any further. In a more specific situation of R -boundedness in L^p -spaces, we also show that R -boundedness can be completely characterised by appropriate weighted norm inequalities.

8.6.a Coincidence with boundedness implies (co)type 2

Recall from Theorem 8.1.3 that an R -bounded family $\mathcal{T} \subseteq \mathcal{L}(X, Y)$ is always uniformly bounded, and the converse holds if X has cotype 2 and Y has type 2. In fact this is the only situation where the converse holds, and we have the following more detailed result.

Proposition 8.6.1. *For non-zero Banach spaces X and Y the following assertions are equivalent:*

- (1) X has cotype 2 and Y has type 2;
- (2) every uniformly bounded family in $\mathcal{L}(X, Y)$ is R -bounded.

In that case,

$$\mathcal{R}(\bar{B}_{\mathcal{L}(X,Y)}) \leq \tau_{2,Y} c_{2,X},$$

where \bar{B}_Z denotes the closed unit ball of a Banach space Z , and we have

$$\tau_{2,Y} = \mathcal{R}(\bar{B}_Y \otimes \{x_0^*\}), \quad c_{2,X} = \mathcal{R}(\{y_0\} \otimes \bar{B}_{X^*}),$$

where $x_0^* \in X^*$ and $y_0 \in Y$ are arbitrary fixed vectors of norm one and $y \otimes x^* \in Y \otimes X^*$ designates the operator $x \in X \mapsto \langle x, x^* \rangle y \in Y$.

Corollary 8.6.2. *A Banach space X is isomorphic to a Hilbert space if and only if every uniformly bounded family in $\mathcal{L}(X)$ is R -bounded.*

Proof of Proposition 8.6.1. (1) \Rightarrow (2): This easy implication and the related estimate was already proved in Theorem 8.1.3.

(2) \Rightarrow (1): We first consider the cotype 2 of X . Fix an arbitrary norm one vector $y_0 \in Y$. For any $x_1, \dots, x_N \in X$ and $x_1^*, \dots, x_N^* \in \bar{B}_{X^*}$, we have

$$\sum_{n=1}^N |\langle x_n, x_n^* \rangle|^2 = \mathbb{E} \left\| \sum_{n=1}^N \varepsilon_n \langle x_n, x_n^* \rangle \right\|^2 = \mathbb{E} \left\| \sum_{n=1}^N \varepsilon_n y_0 \otimes x_n^*(x_n) \right\|^2.$$

If the $x_1, \dots, x_N \in X$ are given, we can pick the $x_1^*, \dots, x_N^* \in \bar{B}_{X^*}$ so that $\langle x_n, x_n^* \rangle = \|x_n\|$, and then

$$\sum_{n=1}^N \|x_n\|^2 = \mathbb{E} \left\| \sum_{n=1}^N \varepsilon_n y_0 \otimes x_n^*(x_n) \right\|^2 \leq \mathcal{R}(\{y_0\} \otimes \bar{B}_{X^*}) \mathbb{E} \left\| \sum_{n=1}^N \varepsilon_n x_n \right\|^2,$$

proving that $c_{2,X} \leq \mathcal{R}(\{y_0\} \otimes \bar{B}_{X^*})$. On the other hand, we always have $|\langle x_n, x_n^* \rangle| \leq \|x_n\|$, and hence

$$\mathbb{E} \left\| \sum_{n=1}^N \varepsilon_n y_0 \otimes x_n^*(x_n) \right\|^2 \leq \sum_{n=1}^N \|x_n\|^2 \leq c_{2,X} \mathbb{E} \left\| \sum_{n=1}^N \varepsilon_n x_n \right\|^2,$$

proving that $\mathcal{R}(\{y_0\} \otimes \bar{B}_{X^*}) \leq c_{2,X}$.

Next we consider the type 2 of Y . Fix an arbitrary $x_0^* \in X^*$ of norm one and $0 < \eta < 1$, and pick $x_0 \in X$ of norm one so that $\langle x_0, x_0^* \rangle \geq \eta$. For any choice of $y_1, \dots, y_N \in Y$, we let $z_n := y_n / \|y_n\|$ if $y_n \neq 0$ and $z_0 := 0$ if $y_n = 0$, so that $z_n \in \bar{B}_Y$ in either case. Then

$$\begin{aligned} \mathbb{E} \left\| \sum_{n=1}^N \varepsilon_n y_n \right\|^2 &\leq \mathbb{E} \left\| \sum_{n=1}^N \varepsilon_n z_n \left\langle \frac{\|y_n\| x_0}{\eta}, x_0^* \right\rangle \right\|^2 \\ &\leq \mathcal{R}(\bar{B}_Y \otimes \{x_0^*\})^2 \mathbb{E} \left\| \sum_{n=1}^N \varepsilon_n \frac{\|y_n\| x_0}{\eta} \right\|^2, \end{aligned}$$

where

$$\mathbb{E} \left\| \sum_{n=1}^N \varepsilon_n \frac{\|y_n\|x_0}{\eta} \right\|^2 = \frac{1}{\eta^2} \mathbb{E} \left| \sum_{n=1}^N \varepsilon_n \|y_n\| \right|^2 = \frac{1}{\eta^2} \sum_{n=1}^N \|y_n\|^2.$$

This proves that $\tau_{2,Y} \leq (1 - \varepsilon)^{-1} \mathcal{R}(\bar{B}_Y \otimes \{x_0^*\})$, and hence $\tau_{2,Y} \leq \mathcal{R}(\bar{B}_Y \otimes \{x_0^*\})$ by letting $\eta \uparrow 1$. On the other hand, if $y_1, \dots, y_N \in \bar{B}_Y$ and $x_1, \dots, x_N \in X$, then

$$\begin{aligned} \mathbb{E} \left\| \sum_{n=1}^N \varepsilon_n y_n \langle x_n, x_0^* \rangle \right\|^2 &\leq \tau_{2,Y}^2 \sum_{n=1}^N \|y_n \langle x_n, x_0^* \rangle\|^2 \leq \tau_{2,Y}^2 \mathbb{E} \left| \sum_{n=1}^N \varepsilon_n \langle x_n, x_0^* \rangle \right|^2 \\ &= \tau_{2,Y}^2 \mathbb{E} \left| \left\langle \sum_{n=1}^N \varepsilon_n x_n, x_0^* \right\rangle \right|^2 \leq \tau_{2,Y}^2 \mathbb{E} \left\| \sum_{n=1}^N \varepsilon_n x_n \right\|^2, \end{aligned}$$

which proves that $\mathcal{R}(\bar{B}_Y \otimes \{x_0^*\}) \leq \tau_{2,Y}$.

The final assertion follows from Kwapien’s isomorphic characterisation of Hilbert spaces as the only Banach spaces with both type 2 and cotype 2 (Theorem 7.3.1). \square

By way of exception we state the analogous result for γ -boundedness as well, since the special properties of Gaussian variables can be used to give an especially satisfactory quantitative form of the statement:

Proposition 8.6.3. *For non-zero Banach spaces X and Y the following assertions are equivalent:*

- (1) X has (Gaussian) cotype 2 and Y has (Gaussian) type 2;
- (2) every uniformly bounded family in $\mathcal{L}(X, Y)$ is γ -bounded.

In that case,

$$\gamma(\bar{B}_Y \otimes \bar{B}_{X^*}) = \gamma(\bar{B}_{\mathcal{L}(X,Y)}) = \tau_{2,Y}^\gamma c_{2,X}^\gamma,$$

where $\tau_{2,Y}^\gamma$ and $c_{2,X}^\gamma$ denote the Gaussian versions of the type 2 and cotype 2 constants.

If $X = Y$ and these equivalent conditions hold, then an isomorphism $J : X \rightarrow H$ to a Hilbert space H can be constructed so that

$$\|J\| \|J^{-1}\| \leq \gamma(\bar{B}_{\mathcal{L}(X)}).$$

Proof. The implication (1) \Rightarrow (2) and the estimate $\gamma(\bar{B}_{\mathcal{L}(X,Y)}) \leq \tau_{2,Y}^\gamma c_{2,X}^\gamma$ are proved exactly as in Proposition 8.6.1, and it is evident that $\gamma(\bar{B}_Y \otimes \bar{B}_{X^*}) \leq \gamma(\bar{B}_{\mathcal{L}(X,Y)})$. The main point is the implication (2) \Rightarrow (1) and the estimate $\tau_{2,Y}^\gamma c_{2,X}^\gamma \leq \gamma(\bar{B}_Y \otimes \bar{B}_{X^*})$, to which we now turn.

Let $x_1, \dots, x_K \in X$ and $y_1, \dots, y_N \in Y$. We pick $x_1^*, \dots, x_K^* \in \bar{B}_{X^*}$ so that $\langle x_k, x_k^* \rangle = \|x_k\|$, and we also choose $z_1, \dots, z_N \in \bar{B}_Y$ so that $y_n = \|y_n\| z_n$. The point is that with this choice

$$\|x_k\| y_n = \langle x_k, x_k^* \rangle \|y_n\| z_n = (z_n \otimes x_k^*)(\|y_n\| x_k),$$

where $z_n \otimes x_k^* \in \bar{B}_Y \otimes \bar{B}_{X^*}$. Now

$$\begin{aligned} \left(\sum_{k=1}^K \|x_k\|^2 \right) \mathbb{E} \left\| \sum_{n=1}^N \gamma_n y_n \right\|^2 &= \mathbb{E} \left\| \sum_{n=1}^N \gamma_n \left(\sum_{k=1}^K \|x_k\|^2 \right)^{1/2} y_n \right\|^2 \\ &= \mathbb{E} \left\| \sum_{n=1}^N \sum_{k=1}^K \gamma_{kn} \|x_k\| y_n \right\|^2, \end{aligned} \quad (8.18)$$

since the Gaussian sequences

$$\left\{ \gamma_n \left(\sum_{k=1}^K \|x_k\|^2 \right)^{1/2} \right\}_{n=1}^N \quad \text{and} \quad \left\{ \sum_{k=1}^K \gamma_{kn} \|x_k\| \right\}_{n=1}^N$$

have the same joint distribution. Now

$$\begin{aligned} \mathbb{E} \left\| \sum_{n=1}^N \sum_{k=1}^K \gamma_{kn} \|x_k\| y_n \right\|^2 &= \mathbb{E} \left\| \sum_{n=1}^N \sum_{k=1}^K \gamma_{kn} (z_n \otimes x_k^*) (\|y_n\| x_k) \right\|^2 \\ &\leq \gamma(\bar{B}_Y \otimes \bar{B}_{X^*})^2 \mathbb{E} \left\| \sum_{n=1}^N \sum_{k=1}^K \gamma_{kn} \|y_n\| x_k \right\|^2 \end{aligned}$$

and, by similar reasoning as in (8.18),

$$\begin{aligned} \mathbb{E} \left\| \sum_{n=1}^N \sum_{k=1}^K \gamma_{kn} \|y_n\| x_k \right\|^2 &= \mathbb{E} \left\| \sum_{k=1}^K \gamma_k \left(\sum_{n=1}^N \|y_n\|^2 \right)^{1/2} x_k \right\|^2 \\ &= \mathbb{E} \left\| \sum_{k=1}^K \gamma_k x_k \right\|^2 \left(\sum_{n=1}^N \|y_n\|^2 \right). \end{aligned}$$

Altogether we have checked that

$$\left(\sum_{k=1}^K \|x_k\|^2 \right) \mathbb{E} \left\| \sum_{n=1}^N \gamma_n y_n \right\|^2 \leq \gamma(\bar{B}_Y \otimes \bar{B}_{X^*})^2 \mathbb{E} \left\| \sum_{k=1}^K \gamma_k x_k \right\|^2 \left(\sum_{n=1}^N \|y_n\|^2 \right).$$

This shows that $c_{2,X}^{\gamma} \tau_{2,Y}^{\gamma} \leq \gamma(\bar{B}_Y \otimes \bar{B}_{X^*})$, as claimed.

The last assertion follows from Kwapien's Theorem 7.3.1. \square

8.6.b Coincidence with γ -boundedness implies finite cotype

Recall from Theorem 8.1.3 that an R -bounded family $\mathcal{T} \subseteq \mathcal{L}(X, Y)$ is always γ -bounded, and the converse holds if X has finite cotype. This is again the only case for the converse implication, and we have the following characterisation:

Theorem 8.6.4. *For a Banach space X the following assertions are equivalent:*

- (1) for any Banach space Y , any γ -bounded family in $\mathcal{L}(X, Y)$ is R -bounded;
- (2) any γ -bounded family in $\mathcal{L}(X, \mathbb{K})$ is R -bounded;
- (3) X has finite cotype.

To prepare for the proof we start with a lemma, which is of some independent interest as it gives a description of certain R -bounded sets in $\mathcal{L}(c_0, \mathbb{K})$.

Lemma 8.6.5. *Let $(c_n)_{n \geq 1}$ be a sequence of scalars. For $n \geq 1$ let $T_n \in \mathcal{L}(c_0, \mathbb{K}) = (c_0)^* = \ell^1$ be given by*

$$T_n = c_n e_n^*,$$

where $(e_n^*)_{n \geq 1}$ is the standard unit basis of ℓ^1 . The sequence $(T_n)_{n \geq 1}$ is R -bounded if and only if $c \in \ell^2$, and in that case we have

$$\mathcal{R}(\{T_n : n \geq 1\}) = \|c\|_{\ell^2}.$$

Proof. Suppose first that $c \in \ell^2$. For all $x_1, \dots, x_N \in c_0$ one has

$$\begin{aligned} \left\| \sum_{n=1}^N \varepsilon_n T_n x_n \right\|_{L^2(\Omega)} &= \left(\sum_{n=1}^N |c_n \langle x_n, e_n^* \rangle|^2 \right)^{1/2} \leq \left(\sum_{n=1}^N |c_n|^2 \|x_n\|^2 \right)^{1/2} \\ &\leq \|c\|_{\ell^2} \sup_{1 \leq n \leq N} \|x_n\| \leq \|c\|_{\ell^2} \left\| \sum_{n=1}^N \varepsilon_n x_n \right\|_{L^2(\Omega; c_0)}, \end{aligned}$$

using Proposition 6.1.5 in the last inequality. By Corollary 8.1.6 this implies that $(T_n)_{n \geq 1}$ is R -bounded, with $\mathcal{R}(\{T_n : n \geq 1\}) \leq \|c\|_{\ell^2}$.

In the converse direction, assume that $(T_n)_{n \geq 1}$ is R -bounded. Fix an integer $N \geq 1$ and consider the standard unit basis vectors e_n of c_0 . Then,

$$\begin{aligned} \left(\sum_{n=1}^N |c_n|^2 \right)^{1/2} &= \left(\sum_{n=1}^N |T_n e_n|^2 \right)^{1/2} = \left\| \sum_{n=1}^N \varepsilon_n T_n e_n \right\|_{L^2(\Omega)} \\ &\leq \mathcal{R}(\{T_n : n \geq 1\}) \left\| \sum_{n \geq 1} \varepsilon_n e_n \right\|_{L^2(\Omega; c_0)} = \mathcal{R}(\{T_n : n \geq 1\}). \end{aligned}$$

It follows that $c \in \ell^2$ and $\|c\|_{\ell^2} \leq \mathcal{R}(\{T_n : n \geq 1\})$. □

This lemma implies that the standard unit basis vectors $e_n^* \in \ell^1$ satisfy

$$\mathcal{R}(\{e_n^* : 1 \leq n \leq N\}) = N^{1/2}.$$

The next lemma establishes a logarithmic improvement for the γ -bound of this family.

Lemma 8.6.6. *Let the notation be as in Lemma 8.6.5 and let $\mathbb{K} = \mathbb{R}$. For all $N \geq 2$,*

$$\left(\frac{N}{4 \log 2N} \right)^{1/2} \leq \gamma(\{e_n^* : 1 \leq n \leq N\}) \leq \left(\frac{10N}{\log N} \right)^{1/2}.$$

Proof. Fix $N \geq 2$. Let $(S_j)_{j=1}^J \subseteq \{e_n^* : 1 \leq n \leq N\}$. We will first show that for all $x_1, \dots, x_J \in c_0$ one has

$$\left\| \sum_{j=1}^J \gamma_j S_j x_j \right\|_{L^2(\Omega)} \leq \left(\frac{10N}{\log N} \right)^{1/2} \left\| \sum_{j=1}^J \gamma_j x_j \right\|_{L^2(\Omega; c_0)}. \quad (8.19)$$

For $1 \leq n \leq N$ let $A_n := \{j : S_j = e_n^*\}$ and set

$$a_n := \left(\sum_{j \in A_n} |\langle x_j, e_n^* \rangle|^2 \right)^{1/2}.$$

By Proposition E.2.20 applied to a real Gaussian sequence $(g_n)_{n \geq 1}$,

$$\begin{aligned} \mathbb{E} \left| \sum_{j=1}^J \gamma_j S_j x_j \right|^2 &= \sum_{j=1}^J |S_j(x_j)|^2 = \sum_{n=1}^N a_n^2 \\ &\leq \frac{5N}{\log N} \left[\mathbb{E} \sup_{1 \leq n \leq N} |g_n a_n| \right]^2 \\ &\leq \frac{5N}{\log N} \mathbb{E} \sup_{1 \leq n \leq N} |g_n a_n|^2 \\ &\leq \frac{10N}{\log N} \mathbb{E} \sup_{1 \leq n \leq N} |\gamma_n a_n|^2 \end{aligned} \quad (8.20)$$

applying Proposition 6.1.21 in the last step. For $1 \leq n \leq N$ set $\Gamma_n := \sum_{j \in A_n} \gamma_j x_j$. Then $(\Gamma_{nn})_{n=1}^N$ is a sequence of independent c_0 -valued random variables and

$$\mathbb{E} |\Gamma_{nn}|^2 = \mathbb{E} |\langle \Gamma_n, e_n^* \rangle|^2 = a_n^2.$$

It follows that the Gaussian sequences $(\Gamma_{nn})_{n=1}^N$ and $(\gamma_n a_n)_{n=1}^N$ have the same joint distribution. Therefore

$$\mathbb{E} \sup_{1 \leq n \leq N} |\gamma_n a_n|^2 = \mathbb{E} \sup_{1 \leq n \leq N} |\Gamma_{nn}|^2. \quad (8.21)$$

For any sequence of signs $\epsilon = (\epsilon_k)_{k \geq 1}$ let $I_\epsilon : c_0 \rightarrow c_0$ be the isometry given by $I_\epsilon((\alpha_k)_{k \geq 1}) = (\epsilon_k \alpha_k)_{k \geq 1}$. Let $(\epsilon'_n)_{n=1}^N$ be a Rademacher sequence on a distinct probability space (Ω', \mathbb{P}') . Then, pointwise on Ω ,

$$\begin{aligned} \sup_{1 \leq n \leq N} |\Gamma_{nn}|^2 &= \sup_{1 \leq n \leq N} \left| \mathbb{E}' \sum_{m=1}^N \epsilon'_m \epsilon'_n \Gamma_{mn} \right|^2 \\ &\leq \left\| \mathbb{E}' \left[I_{\epsilon'} \left(\sum_{m=1}^N \epsilon'_m \Gamma_m \right) \right] \right\|^2 \\ &\leq \mathbb{E}' \left\| I_{\epsilon'} \left(\sum_{m=1}^N \epsilon'_m \Gamma_m \right) \right\|^2 = \mathbb{E}' \left\| \sum_{m=1}^N \epsilon'_m \Gamma_m \right\|^2, \end{aligned}$$

where we used that $I_{\varepsilon'(\omega')}$ is an isometry for each $\omega' \in \Omega'$. Combining the above estimate with (8.21) and using that $\Gamma_1, \dots, \Gamma_N$ are independent and symmetric we obtain

$$\mathbb{E} \sup_{1 \leq n \leq N} |\gamma_n a_n|^2 \leq \mathbb{E} \mathbb{E}' \left\| \sum_{m=1}^N \varepsilon'_m \Gamma_m \right\|^2 = \mathbb{E} \left\| \sum_{m=1}^N \Gamma_m \right\|^2 = \mathbb{E} \left\| \sum_{j=1}^J \gamma_j x_j \right\|^2.$$

Combining this estimate with (8.20), (8.19) follows.

To prove the lower estimate, let $c_N = \gamma(e_n^* : 1 \leq n \leq N)$. Then, for all $N \geq 2$, we may apply Proposition E.2.21 to obtain

$$\begin{aligned} N &= \mathbb{E} \left| \sum_{n=1}^N \gamma_n \langle e_n, e_n^* \rangle \right|^2 \leq c_N^2 \mathbb{E} \left\| \sum_{n=1}^N \gamma_n e_n \right\|^2 \\ &= c_N^2 \mathbb{E} \sup_{1 \leq n \leq N} |\gamma_n|^2 \leq 4c_N^2 \log(2N), \end{aligned}$$

where as before we applied Proposition 6.1.21 to reduce to real Gaussians. \square

Proof of Theorem 8.6.4. The implication (1) \Rightarrow (2) is trivial, and the implication (3) \Rightarrow (1) along with the estimate has already been proved.

(2) \Rightarrow (3): Suppose that X does not have finite cotype. We first claim that for every $M > 0$ there exists a finite family $\mathcal{S} \subseteq \mathcal{L}(X, \mathbb{K})$ such that $\gamma(\mathcal{S}) \leq 1$ and $\mathcal{R}(\mathcal{S}) \geq M$. Indeed, fix $M > 0$. By the Maurey–Pisier theorem 7.3.8, X contains the spaces ℓ_N^∞ λ -uniformly for some $\lambda > 1$. Therefore, for any $N \geq 1$ there exists a bounded linear operator $J_N : \ell_N^\infty \rightarrow X$ such that

$$\|x\| \leq \|J_N x\| \leq \lambda \|x\|$$

for all $x \in \ell_N^\infty$. Let $X_N = J_N(\ell_N^\infty)$ and let $I_N : X_N \rightarrow \ell_N^\infty$ be the unique invertible operator such that $J_N I_N$ is the identity on X_N . Then $\|I_N\| \leq 1$. Let $(e_n^*)_{n=1}^N$ be the standard basis in ℓ_N^1 . For $1 \leq n \leq N$ let $x_n^* \in X_N^*$ be defined by $x_n^* := I_N^* e_n^*$, and let $z_n^* \in X^*$ be a Hahn-Banach extension of x_n^* .

Set $\mathcal{S}_N := \{z_n^* : 1 \leq n \leq N\}$ and $\mathcal{T}_N := \{e_n^* : 1 \leq n \leq N\}$. By Lemmas 8.6.6 and 8.6.5 we have

$$\gamma(\mathcal{T}_N) \leq (10N/\log N)^{1/2}, \quad \mathcal{R}(\mathcal{T}_N) = N^{1/2}.$$

For all $1 \leq n \leq N$ we have $z_n^* = e_n^* \circ \tilde{I}_N$, where the operator $\tilde{I}_N : X \rightarrow \ell_N^\infty$ is defined by $\tilde{I}_N x := (\langle x, z_n^* \rangle)_{n=1}^N$ and satisfies $\|\tilde{I}_N\| = \|I_N\| \leq 1$. It follows that

$$\gamma(\mathcal{S}_N) \leq \|\tilde{I}_N\| \gamma(\mathcal{T}_N) \leq \left(\frac{10N}{\log N} \right)^{1/2}$$

and

$$N^{1/2} = \mathcal{R}(\mathcal{T}_N) \leq \lambda \mathcal{R}(\mathcal{S}|_{X_N}) \leq \lambda \mathcal{R}(\mathcal{S}_N).$$

By a re-scaling, the claim follows.

By the claim, for each $n \geq 1$ we can find a family $\mathcal{S}_n \subseteq \mathcal{L}(X, \mathbb{K})$ such that $\gamma(\mathcal{S}_n) \leq 1$ and $\mathcal{R}(\mathcal{S}_n) \geq 4^n$. Now let $\mathcal{S} = \bigcup_{n \geq 1} 2^{-n} \mathcal{S}_n$. Clearly, $\gamma(\mathcal{S}) \leq \sum_{n \geq 1} 2^{-n} \gamma(\mathcal{S}_n) \leq 1$. On the other hand, for every $n \geq 1$, $\mathcal{R}(\mathcal{S}) \geq \mathcal{R}(2^{-n} \mathcal{S}_n) \geq 2^{-n} 4^n = 2^n$ and hence \mathcal{S} is not R -bounded. \square

8.7 Notes

The origins of R -boundedness

The notion of R -boundedness has its roots in the theory of Fourier multipliers and the results discussed in Section 8.3. In particular, Proposition 8.3.1 concerning the R -boundedness of the interval multipliers Δ_I is the analogue on $L^p(\mathbb{R}; X)$ of a similar result on $L^p(\mathbb{T}; X)$ from Bourgain [1986], which has been often referred to as the “first implicit use of R -boundedness”. However, the scalar-valued original of this inequality, stated by Zygmund [1938] as a square function estimate (i.e., ℓ^2 -boundedness), already made use of a reformulation in terms of the Rademacher functions (i.e., R -boundedness) to actually prove it. Clearly square function estimates in the form of ℓ^2 -boundedness are at the heart of Littlewood–Paley theory, e.g. for the partial sums of these decompositions. This was already pointed out in Muckenhoupt and Stein [1965] and Bonami and Clerc [1973].

A notable implicit appearance of R -boundedness in the classical literature is the negative solution of the ball multiplier problem — the question of $L^p(\mathbb{R}^d)$ -boundedness of the Fourier multiplier $\Delta_{B(0,1)}$ (see (8.7)) whose symbol is the indicator of the unit ball $B(0,1) \subseteq \mathbb{R}^d$ — by Fefferman [1971]. Namely, it had been observed earlier by Y. Meyer (see Fefferman [1971, Lemma 1]) that if this boundedness were true for a given p , then the family of Fourier multipliers $\{\Delta_H : H \subseteq \mathbb{R}^2 \text{ a half-space}\}$ would be R -bounded in $L^p(\mathbb{R}^2)$, and the core of Fefferman’s argument, “based on a slight variant of (Schönberg’s improvement of) Besicovitch’s construction for the Kakeya needle problem”, was to show that this R -boundedness fails for all $p \neq 2$.

In any case, Bourgain [1986] was probably the first to use this notion in the context of analysis in Banach spaces.

The explicit use of R -boundedness has a history of its own. Edwards and Gaudry [1977] defined the *Riesz property* of a collection \mathcal{E} of sets (rather than operators) $E \subseteq \mathbb{R}^n$ as (in our language) the R -boundedness of the multiplier operators (defined in (8.7)) $\Delta_E = T_{\mathbf{1}_E}$, $E \in \mathcal{E}$, on $L^p(\mathbb{R}^n)$. This definition and name was obviously motivated by the classical versions of Proposition 8.3.1 and its multivariate extension in Lemma 8.3.13, which guaranteed this property for the family of all (axes-parallel) rectangles as a corollary of the L^p -boundedness of the Hilbert transform — in the scalar case a classical theorem of Riesz [1928].

The notion of R -boundedness of a family of operators, as we have used it, was first formally introduced by Berkson and Gillespie [1994], who called it the R -property, making connections to the works of both Bourgain [1986] and Edwards and Gaudry [1977]. The same definition under the now standard name of R -boundedness was adopted by Clément, De Pagter, Sukochev, and Witvliet [2000], who reinterpreted the ‘ R ’ as ‘randomised’ and provided a detailed analysis including many of the results that we have discussed in Section 8.1. The alternative interpretation of the ‘ R ’ as ‘Rademacher’ (with obvious reference to the Rademacher variables used in the definition) has been proposed by Kalton and Weis [2001]. This more specific name is perhaps preferable in order to make a distinction from other possible versions of randomised boundedness such as the γ -boundedness (Gaussian boundedness), at least in contexts where both notions make an appearance. Fortunately enough, everyone could agree on the letter ‘ R ’.

General treatments of R -boundedness from the early years of the theory are provided by Denk, Hieber, and Prüss [2003] and Kunstmann and Weis [2004].

Section 8.1

The key properties of R -boundedness expressed in Propositions 8.1.5 (testing R -boundedness with distinct operators), 8.1.21 (stability under convex hulls) and 8.1.22 (in the case of strong operator closure) were all stated and proved in the first systematic analysis of R -boundedness by Clément, De Pagter, Sukochev, and Witvliet [2000], but the convexity was already implicit in the work of Bourgain [1986]. Whether γ -boundedness can be tested with distinct operators is an open problem. Krivine [1974] showed that a family consisting of a single operator $T \in \mathcal{L}(X, Y)$ is ℓ^2 -bounded by $K_G \|T\|$, where K_G is the Grothendieck constant (see Lindenstrauss and Tzafriri [1979, Theorem 1.f.14]). This was used in Kwapień, Veraar, and Weis [2016] to show that ℓ^2 -boundedness can be tested with distinct operators. Proposition 8.1.24 is taken from Weis [2001b]. Proposition 8.1.20 is due to Van Gaans [2006].

Theorem 8.1.12 on the R -boundedness of conditional expectations is just a reformulation of Theorem 4.2.23; it was stated as a lemma by Bourgain [1984, 1986], extending the scalar-valued version due to Stein [1970b]. The ball-averaging version in Proposition 8.1.13 is from Hytönen, Van Neerven, and Portal [2008b], which contains the following elaboration: if X is a UMD space, $1 < p < \infty$, and $L^p(\mathbb{R}^d; X)$ has type $t \in (1, 2]$, then for each $\alpha \geq 1$ the family \mathcal{A}_α of averaging operators

$$f \mapsto A_B^\alpha f := \mathbf{1}_{\alpha B} \int_B f \, dx,$$

where B runs over all balls in \mathbb{R}^d , is R -bounded on $L^p(\mathbb{R}^d; X)$ with

$$\mathcal{R}(\mathcal{A}_\alpha) \leq C(1 + \log \alpha) \alpha^{d/t}$$

with a constant C depending only on X , p , t and d . This result plays a role in a change-of-aperture theorem for so-called *tent spaces* of X -valued functions. The proof is more difficult and depends on dyadic techniques developed by Figiel [1988] and Hytönen, McIntosh, and Portal [2008a]. For $X = \mathbb{K}$ the logarithmic factor was subsequently removed in Auscher [2011].

Proposition 8.1.14 appears in Maas and Van Neerven [2009]. The observation in Proposition 8.1.18 is the idea behind the multiplier results in Girardi and Weis [2003a].

Counterexamples

The essence of Proposition 8.1.16 (the failure of the R -boundedness of translations) is folklore. It can be elaborated as follows:

Example 8.7.1. Consider the Besov space $X = B_{p,1}^s(\mathbb{R})$ and let $Y = L^p(\mathbb{R})$, with $p \in [1, \infty)$ and $s > 0$. Let $\mathcal{S} = \{S(u) \in \mathcal{L}(X, Y) : u \in \mathbb{R}\}$, where $S(u)f(v) = f(v + u)$ are the left-translation operators. Then

- (1) \mathcal{S} is R -bounded if $s > |1/p - 1/2|$;
- (2) \mathcal{S} is not R -bounded if $s < |1/p - 1/2|$;
- (3) \mathcal{S} is R -bounded if $s = 1/2$ and $p = 1$;
- (4) \mathcal{S} is *semi- R -bounded* (see Definition 8.7.3) if $1 \leq p < 2$ and $s = 1/p - 1/2$.

Assertions (1) and (2) are from Hytönen and Veraar [2009] and (3) and (4) from Veraar and Weis [2010]. It seems to be unknown whether \mathcal{S} is R -bounded if $s = |1/p - 1/2|$ and $p \in (1, \infty)$. If $p \in [2, \infty)$, then $\{S(u) \in \mathcal{L}(X) : u \in \mathbb{R}\}$ is *semi- R -bounded* (this notion is introduced and discussed below); this follows from the remarks below Definition 8.7.3 and the fact that X has type 2.

In Hoffmann, Kalton, and Kucherenko [2004] various negative results for R -boundedness of operators on L^1 -spaces and $C(K)$ -spaces have been obtained. In particular, they obtained the following negative result:

Theorem 8.7.2. *Let X be a separable Banach space supporting an R -bounded C_0 -semigroup $(S(t))_{t \geq 0}$ consisting of weakly compact operators.*

- (1) *If $X = L^1(\mu)$, then X is isomorphic to ℓ^1 (i.e., μ is purely atomic).*
- (2) *If $X = C(K)$, then X is isomorphic to c_0 .*

Since differential operators on a bounded domain D often have compact resolvents, the semigroups generated by such operators on $L^1(D)$ and $C(\overline{D})$ are generally not R -bounded. A characterisation of R -boundedness in $L^1(\mu)$ was obtained in Kalton and Kucherenko [2008]; with the results of this paper one also obtains negative results for certain differential operators on unbounded domains.

Semi- R -boundedness

The following weaker version of R -boundedness has been introduced and studied in [Hoffmann, Kalton, and Kucherenko \[2004\]](#).

Definition 8.7.3. *A collection $\mathcal{T} \subseteq \mathcal{L}(X, Y)$ is said to be semi- R -bounded if there exists a constant $C \geq 0$ such that for all finite sequences $(T_n)_{n=1}^N$ in \mathcal{T} , scalars $(a_n)_{n=1}^N$, and $x \in X$,*

$$\left(\mathbb{E} \left\| \sum_{n=1}^N \varepsilon_n T_n a_n x \right\|^2 \right)^{1/2} \leq C \left(\sum_{n=1}^N |a_n|^2 \right)^{1/2} \|x\|.$$

The least admissible constant C in the above inequality is called the semi- R -bound, and is denoted by $\mathcal{R}_{\text{semi}}(\mathcal{T})$.

It is shown in [Hoffmann, Kalton, and Kucherenko \[2004\]](#) that a Banach space X has type 2 if and only if every uniformly bounded subset of $\mathcal{L}(X)$ is semi- R -bounded, and that in a separable Banach space, every semi- R -bounded subset of $\mathcal{L}(X)$ is R -bounded if and only if either X is isomorphic to ℓ^2 or every bounded operator from X to ℓ^2 is absolutely summing. Examples of spaces with the latter property include the L^1 -spaces. Parts of this result have been extended to operator families in $\mathcal{L}(X, Y)$ in [Blasco, Fourie, and Schoeman \[2007\]](#) and [Veraar and Weis \[2010\]](#). The latter paper also contains the following simple observation:

Proposition 8.7.4. *Let X be a Banach space and fix a constant $C \geq 0$. For any family of operators $\mathcal{T} \subseteq \mathcal{L}(X)$ the following assertions are equivalent:*

- (1) \mathcal{T} is semi- R -bounded with constant $\mathcal{R}_{\text{semi}}(\mathcal{T}) \leq C$;
- (2) $\mathcal{T}x = \{Tx : T \in \mathcal{T}\}$, considered as a subset of $\mathcal{L}(\mathbb{K}; Y)$, is R -bounded for all $x \in X$ with constant $\mathcal{R}(\mathcal{T}x) \leq C\|x\|$.

Using this characterisation, many results on R -boundedness can be extended to semi- R -boundedness.

Different versions of R -boundedness have been studied in [Kalton and Weis \[2001\]](#) in connections with the H^∞ -calculus for sectorial operators.

Section 8.2

The results of [Section 8.2.a](#), on the deduction of R -boundedness from pointwise domination, are mostly folklore. Some of these statements in the explicit language of R -boundedness appear in [Weis \[2001a\]](#). Maximal estimates to prove R -boundedness of the semigroups with Gaussian bounds were already used in [Denk, Hieber, and Prüss \[2003\]](#).

The notion of ℓ^s -boundedness (sometimes called R_s -boundedness) is standard in harmonic analysis. It is important here that, when choosing operators from \mathcal{T} , repetitions are allowed. Indeed, [Kunstmann, P. C. and Ullmann](#)

[2014] show that a single (!) operator on a Hilbert space may not be ℓ^s -bounded if $s \neq 2$. Weis [2001a] used ℓ^s -boundedness for different values of s to derive R -boundedness results for a large class of semigroups on L^p -spaces by an interpolation argument. These results will be explained in detail in Section 10.7.d. In Blunck and Kunstmann [2002] and Kunstmann and Weis [2004], ℓ^s -boundedness and R -boundedness results are derived from off-diagonal estimates. The notion of ℓ^s -boundedness was further studied by Kunstmann, P. C. and Ullmann [2014] in connection with functional calculus. In Amenta, Lorist, and Veraar [2017b] the more restrictive notion of $\ell^r(\ell^s)$ -boundedness was introduced in order to study Fourier multiplier theorems with operator-valued symbols on Banach lattices.

Theorem 8.2.6, which deduces ℓ^s -boundedness from uniform weighted estimates, is due to Rubio de Francia [1984]. A thorough modern treatment of this and related topics is provided by Cruz-Uribe, Martell, and Pérez [2011]. Typical examples of classes of operators satisfying such weighted estimates are Calderón–Zygmund operators and in particular Fourier multiplier operators (see García-Cuerva and Rubio de Francia [1985, Theorems IV.3.1 and IV.3.9]). Fröhlich [2007] applied weighted estimates to obtain R -analyticity for the Stokes semigroup. Similar applications to semigroups and evolution families generated by elliptic equations can be found in Haller-Dintelmann, Heck, and Hieber [2003, 2006] and Gallarati and Veraar [2017a,b], respectively.

The weighted characterisations of ℓ^s -boundedness of Propositions 8.2.8 and 8.2.10 are due to Rubio de Francia [1982] (see also García-Cuerva and Rubio de Francia [1985]). We follow the presentation of Grafakos [2009, Section 9.5.3] with minor changes. Lemma 8.2.9 is due to Fan [1953] and an elementary proof can be found in the appendices of both García-Cuerva and Rubio de Francia [1985] and Grafakos [2008]. Proposition 8.2.8 was applied in Gallarati, Lorist, and Veraar [2016] to derive R -boundedness results for certain integral operators of non-convolution type.

Another general tool for checking R -boundedness in $L^p(\mathbb{R}^d)$ has been introduced quite recently:

Theorem 8.7.5 (Bateman and Thiele [2013]). *Let \mathcal{T} be a family of sub-linear operators uniformly bounded on $L^2(\mathbb{R}^d)$ and let $1 < p_0 < p_1 < \infty$. Suppose that the following holds for both $i = 0, 1$: There is a constant C_i such that for all $H, G \subseteq \mathbb{R}^d$ of finite positive measure, there are major subsets $H' \subseteq H$ and $G' \subseteq G$, namely*

$$|H'| \geq \frac{1}{2}|H|, \quad |G'| \geq \frac{1}{2}|G|,$$

such that, for every $T \in \mathcal{T}$ and $f \in L^2(\mathbb{R}^d)$, we have

$$\left(\int_{G'} |T(\mathbf{1}_{H'} f)|^2 dx \right)^{1/2} \leq C_i \left(\frac{|G|}{|H|} \right)^{1/2-1/p_i} \|f\|_{L^2(\mathbb{R}^d)}.$$

Then $\mathcal{T} \subseteq \mathcal{L}(L^p(\mathbb{R}^d))$ is ℓ^2 -bounded for every $p \in (p_0, p_1)$.

The original application of this tool by [Bateman and Thiele \[2013\]](#) was the proof of the $L^p(\mathbb{R}^2)$ -boundedness, for $p \in (\frac{3}{2}, \infty)$, of the Hilbert transform along a one-variable vector field $v : \mathbb{R} \rightarrow \mathbb{R}^2 \setminus \{0\}$, namely

$$H_v f(x) := \text{p. v.} \int_{\mathbb{R}} f(x - tv(x_1)) \frac{dt}{t}, \quad x = (x_1, x_2) \in \mathbb{R}^2.$$

The core of their argument is to show the ℓ^2 -boundedness of a family of frequency-truncated versions of H_v with the help of [Theorem 8.7.5](#). Further applications of [Theorem 8.7.5](#), to reprove several classical inequalities of harmonic analysis, have been explored by [Demeter and Silva \[2015\]](#).

Section 8.3

[Proposition 8.3.1](#) on the R -boundedness of the interval multipliers Δ_I is a birthplace of R -boundedness and was already discussed at the beginning of these Notes. The Marcinkiewicz multiplier theorem [8.3.9](#) is a classical result of [Marcinkiewicz \[1939\]](#) in the scalar-valued case, and was extended to scalar-valued multipliers m in UMD spaces by [Bourgain \[1986\]](#). The concise argument of [Bourgain \[1986\]](#) was substantially elaborated by [Zimmermann \[1989\]](#), who proved the multivariate extension as in [Theorem 8.3.19](#) for scalar-valued m . One can clearly identify early versions of [Theorem 8.3.4](#) (which is implicit in [Bourgain \[1986\]](#)) and [Proposition 8.3.15](#) (again for scalar-valued m) in the paper of [Zimmermann \[1989\]](#). The first operator-valued multiplier theorem was the Mihlin-type result here stated as [Corollary 8.3.11](#) and first proved by [Weis \[2001b\]](#). The operator-valued versions of the Marcinkiewicz-type theorems [8.3.9](#) and [8.3.19](#) were shortly after obtained by [Štrkalj and Weis \[2007\]](#). (The publication year of this paper, “received by the editors October 1, 1999”, is exceptionally misleading.) Independently, these results were also obtained by [Haller, Heck, and Noll \[2002\]](#). The statement of the multiplier theorem of Mihlin [\[1956\]](#), in [Corollary 8.3.11](#), as a corollary to that of [Marcinkiewicz \[1939\]](#) agrees with the historical order of developments in the scalar-valued case, although originally this ‘corollary’ was not quite as immediate, as the theorem of [Marcinkiewicz \[1939\]](#) was formulated in the periodic case. The same applies to the multivariate [Corollary 8.3.22](#), whose scalar-valued version is due to [Lizorkin \[1963\]](#). In [Kunstmann and Weis \[2004\]](#) a direct approach to the operator-valued Mihlin theorems is given which is also based on Stečĭn-type multiplier theorems as in [Theorem 8.3.4](#) and [Proposition 8.3.15](#). However, here only multipliers satisfying integral conditions as in [Lemmas 8.3.8](#) and [8.3.16](#) in place of the more general variational norm are considered. [Denk, Hieber, and Prüss \[2003\]](#) contains a further variations of the R -boundedness approach to operator-valued multiplier theorems.

The failure of the multivariate Marcinkiewicz [Theorem 8.3.19](#) in general UMD spaces was also discovered by [Zimmermann \[1989\]](#), who gave a counterexample in the Schatten classes \mathcal{C}^p with $p \in (1, \infty) \setminus \{2\}$. The more precise

result of Proposition 8.3.25, that the additional requirement on X is exactly Pisier's contraction property, is due to Lancien [1998]. We should recall, however, that a version of the multivariate multiplier theorem is also valid for general UMD spaces, but this requires somewhat stronger assumptions on the multiplier m than Theorem 8.3.19 or its Corollary 8.3.22, in exchange for the weaker assumptions on the space (see Theorem 5.5.10). This variant of the multivariate multiplier theorem has the same vector-valued history as Theorem 8.3.19.

That Pisier's contraction property leads to the R -boundedness of collections of multiplier operators, as in Theorem 8.3.12 and Corollary 8.3.23, was first established by Venni [2003], and independently by Girardi and Weis [2003b] by a simpler and more general approach. The necessity of Pisier's contraction property (Proposition 8.3.24) for these results was shown by Hytönen and Weis [2008]. This result can be elaborated in the following ways:

1. It suffices to consider just the special multipliers $m_s(\xi) = (2\pi|\xi|)^{i2s}$, whose associated operators are $T_{m_s} = (-\Delta)^{is}$, the imaginary powers of the Laplacian (see Proposition 10.5.4).
2. It is possible to build a single multiplier $m \in C^\infty(\mathbb{R} \setminus \{0\})$ with the bounds $|\xi|^k |\partial^k m(\xi)| \leq C_k$ for all $k \in \mathbb{N}$, such that for any $p \in (1, \infty)$, we have
 - $T_m \in \mathcal{L}(L^p(\mathbb{R}; X))$ if and only if X is a UMD space, and
 - $\{T_{m(2^j \cdot)} : j \in \mathbb{Z}\}$ is an R -bounded subset of $\mathcal{L}(L^p(\mathbb{R}; X))$ if and only if X is a UMD space with Pisier's contraction property.

This is essentially based on implanting all the possible (countably many, after restricting to $\alpha_{kn} = \pm 1$) finite constructions from the proof of Proposition 8.3.24 into a single multiplier m ; see Hytönen [2007c].

It might be interesting to note that the original proofs, by Hytönen and Weis [2008] and Lancien [1998], of both Propositions 8.3.24 and 8.3.25 on the necessity of Pisier's contraction property for different multiplier theorem, used Pisier's Theorem 6.5.1 on random versus trigonometric sums to deduce the estimates (8.10) and (8.11) from their trigonometric variants right above each of them. We have replaced the application of this non-trivial theorem by a simple randomisation argument.

Beyond Mihlin's theorem without Pisier's contraction property

Fix a positive vector $\alpha \in (0, \infty)^d$. The associated *anisotropic size* $\varrho_\alpha(x)$ of $x \in \mathbb{R}^d$, introduced by Fabes and Rivière [1966], is defined as the unique positive solution ϱ of

$$\sum_{i=1}^d \frac{x_i^2}{\varrho^{2\alpha_i}} = 1$$

if $x \neq 0$, and $\varrho_\alpha(0) := 0$. The following result is from Hytönen [2007a]:

Theorem 8.7.6. *Let X be a UMD space and $p \in (1, \infty)$. If $m \in C^d(\mathbb{R}^d \setminus \{0\}; \mathcal{L}(X))$ satisfies*

$$\mathcal{R}(\{\varrho_\alpha(\xi)^{\alpha \cdot \beta} \partial^\beta m(\xi) : \xi \in \mathbb{R}^d \setminus \{0\}, \beta \in \{0, 1\}^d\}) < \infty,$$

then m is a Fourier multiplier on $L^p(\mathbb{R}^d; X)$.

Note that $\varrho_\alpha(x)^{\alpha_i} \geq |x_i|$, so that $\varrho_\alpha(\xi)^{\alpha \cdot \beta} \geq |\xi^\beta|$, so that the assumption on the multiplier m is stronger than the one in Corollary 8.3.22. For this reason, Theorem 8.7.6 seems not to have a scalar-valued predecessor, as such a result was never needed given the existence of the stronger Corollary 8.3.22. In the vector-valued case, the advantage of Theorem 8.7.6 over Corollary 8.3.22 is the fact that Theorem 8.7.6 does not require Pisier's contraction property. If $\alpha = (1, \dots, 1)$, the anisotropic size reduces to $\varrho_\alpha(x) = |x|$, and Theorem 8.7.6 reduces to Theorem 5.5.10.

Another interesting set of multipliers outside the Mihlin class consists of $m(\xi) = (|\xi_i|/|\xi|)^s$ with $s > 0$. The boundedness $T_m \in \mathcal{L}(L^p(\mathbb{R}^d; X))$ for all UMD spaces X and $p \in (1, \infty)$ has been established by *ad hoc* arguments by Hytönen [2007c] and Hytönen, Li, and Naor [2016] (showing a d -independent bound), and finally by a systematic approach with a sharp bound as a special case of results for so-called *Lévy multipliers* by Yaroslavstev [2017], who extended the results of Bañuelos, Bielaszewski, and Bogdan [2011] to the vector-valued setting.

Section 8.4

The duality result in Proposition 8.4.1 is due to Kalton and Weis [2001]. The counterexample Example 8.4.2 on ℓ^1 is folklore. It was shown in Kwapien, Veraar, and Weis [2016] that K -convexity of X is also necessary in Proposition 8.4.1(1) when quantifying over all R -bounded subsets of $\mathcal{L}(X, Y)$. The biduality result of Proposition 8.4.3 is due to Hoffmann, Kalton, and Kucherenko [2004] with a similar proof. An alternative proof using the principle of local reflexivity can be found in De Pagter and Ricker [2010]. Proposition 8.4.4 on the permanence of R -boundedness under interpolation can be found in Kaip and Saal [2012]. Lemma 8.4.5 is taken from Girardi and Weis [2003a]. Proposition 8.4.6 is a variation of a result in Kalton and Weis [2001], where the result is stated under a more restrictive unconditionality assumption.

Section 8.5

Theorem 8.5.2 and Propositions 8.5.10 and 8.5.11 are taken from Weis [2001b], which also contains slightly weaker formulations of Theorem 8.5.4 and Proposition 8.5.7. Proposition 8.5.8 is taken from Kunstmann and Weis [2004].

A proof of the Riemann mapping theorem, in its formulation used in the proof of Proposition 8.5.10, can be found in Carathéodory [1954, pp. 88–107].

The results of Section 8.5.c are from Hytönen and Veraar [2009] where further variations results can be found as well. Instead of the Fourier analytic approach, our proof of Theorem 8.5.21 uses the description of Sobolev

spaces of fractional order by difference norms. Theorem 8.5.12 was used by Kriegler [2014] and Kriegler and Weis [2017] to obtain R -boundedness for the Hörmander functional calculus for free.

Mapping properties of the vector-valued Sobolev spaces $W^{1,p}(D; X)$ and $W_0^{1,p}(D; X)$ have been studied in recent paper Arendt and Kreuter [2016]. Incidentally, it contains an independent (and different) proof to Theorem 2.5.7(2).

Section 8.6

Proposition 8.6.1 is taken from Arendt and Bu [2002] who, so they write, “are indebted to C. Le Merdy and G. Pisier for communicating them this result.” The quantitative estimates of that proposition are implicit in Arendt and Bu [2002], but in the Gaussian version given in Proposition 8.6.3 they may be new. The difficult implication of Theorem 8.6.4 is taken from Kwapien, Veraar, and Weis [2016]. Using a deep result of Talagrand [1992a] on the cotype of operators on ℓ_N^∞ , these authors also proved the following characterisation:

Theorem 8.7.7. *Let X and Y be Banach lattices with Y non-zero. The following assertions are equivalent:*

- (1) every R -bounded family $\mathcal{T} \subseteq \mathcal{L}(X, Y)$ is ℓ^2 -bounded.
- (2) every γ -bounded family $\mathcal{T} \subseteq \mathcal{L}(X, Y)$ is ℓ^2 -bounded.
- (3) X has finite cotype.

In this case, $\ell^2(\mathcal{T}) \lesssim_X \mathcal{R}(\mathcal{T}) \approx_X \gamma(\mathcal{T})$.

A similar (but simpler) result with the roles of R -boundedness and ℓ^2 -boundedness reversed, is proved there as well and in this case it characterises finite cotype of Y .

Further results

There are many further important applications of R -boundedness to the H^∞ -functional calculus (see Chapter 10) and several related topics which will be discussed in depth in Volume III. Let us mention here some applications which we will not pursue any further.

Representations of amenable groups

As a consequence of the classical unitarisation theorem of Day and Dixmier (see Pisier [2001]), every bounded strongly continuous representation $\pi : G \rightarrow \mathcal{L}(X)$ of an amenable, locally compact group G , has a bounded extension $\tilde{\pi} : C^*(G) \rightarrow \mathcal{L}(X)$ to the group C^* -algebra $C^*(G)$ of G if X is a Hilbert space. In Le Merdy [2010] this result has been extended to general Banach spaces as follows: If $\pi : G \rightarrow \mathcal{L}(X)$ is a bounded strongly continuous representation, then π has a unique extension to a homomorphism $\tilde{\pi} : C^*(G) \rightarrow \mathcal{L}(X)$

with γ -bounded range if and only if π has γ -bounded range. For Banach spaces X with Pisier's contraction property, it is furthermore shown that $\pi : G \rightarrow \mathcal{L}(X)$ extends to a bounded homomorphism $\tilde{\pi} : C^*(G) \rightarrow \mathcal{L}(X)$ if and only if the range of π is R -bounded, and in that case the range is even matricially R -bounded. For $G = \mathbb{Z}$ one has $C^*(G) = C(\mathbb{T})$ and the following result is obtained as a special case: If X has Pisier's contraction property and $T \in \mathcal{L}(X)$ is invertible, then there exists a constant $C \geq 0$ such that

$$\left\| \sum_{n \in \mathbb{Z}} T^n \right\| \leq C \sup_{z \in \mathbb{T}} |c_n z^n|$$

for all finitely non-zero complex sequences $(c_n)_{n \in \mathbb{Z}}$ if and only if the family $\{T^n : n \in \mathbb{Z}\}$ is R -bounded. Earlier R -boundedness results for the range of a bounded representation $\pi : C(K) \rightarrow \mathcal{L}(X)$ appeared in [De Pagter and Ricker \[2007\]](#). Related results can be found in [Kriegler and Le Merdy \[2010\]](#).

Representation of R -bounded sets on Hilbert spaces

In this volume we have encountered many instances of results that are classical in Hilbert spaces and extend to the Banach space setting if one adds appropriate R -boundedness assumptions. Contemplating this body of results one cannot escape the impression that R -bounded sets of operators behave very much like uniformly bounded sets of Hilbert space operators. From a factorisation theorem due to [Maurey \[1974a\]](#) it follows that for ℓ^s -bounded sets of operators on L^p (see the Notes of Section 8.2) there exists a factorisation through L^s (see also [García-Cuerva and Rubio de Francia \[1985\]](#)). In [Le Merdy and Simard \[2002\]](#) a different proof of the factorisation theorem was given in the special case $s = 2$ using the theory of completely bounded maps.

The following factorisation through Hilbert spaces of R -bounded sets on general Banach spaces is given in [Kalton and Weis \[preprint\]](#).

Theorem 8.7.8. *Let X be a Banach space and let $\mathcal{T} \subseteq \mathcal{L}(X)$ be a closed, absolutely convex, R -bounded set of operators. Let B_1 be the Banach space obtained by norming $\bigcup_{n \geq 1} n\tau$ with the Minkowski functional of τ . Then there exists a Hilbert space H , a closed sub-algebra B_2 of $\mathcal{L}(H)$, and continuous linear multiplicative maps $\rho : B_1 \rightarrow B_2$ and $\pi : B_2 \rightarrow \mathcal{L}(X)$ such that*

$$\pi \circ \rho(T) = T$$

for all $T \in \tau$.

Although this theorem is not strong enough to deduce many properties of τ from the properties of the set of Hilbert space operators $\rho(\tau)$ in $\mathcal{L}(H)$, it does give some heuristic explanation of the observed phenomena and explains the many uses of R -boundedness in Analysis.

Square functions and radonifying operators

A deep concept in mathematics is usually not an idea in its pure form, but rather takes various shapes depending on the uses it is put to. The same is true of square functions. These appear in a variety of forms, and while in spirit they are all the same, in actual practice they can be quite different. Thus the metamorphosis of square functions is all important.

—Elias M. Stein

Many of the results earlier in this book so far illustrate, among the class of all Banach spaces, the distinguished role of Hilbert spaces. Perhaps luckily for those who choose to find their living in more barren spaces, it is often possible to identify useful Hilbertian components for objects in other Banach spaces of interest.

Square functions provide a well-known representation of classical function space norms in terms of expressions involving a quadratic component. Examples to keep in mind include norm equivalences such as the Littlewood–Paley inequality for functions $f \in L^p(\mathbb{R})$, $p \in (1, \infty)$,

$$\|f\|_{L^p(\mathbb{R})} \approx \left\| \left(\int_0^\infty \left| t \frac{\partial}{\partial t} u(t, \cdot) \right|^2 \frac{dt}{t} \right)^{1/2} \right\|_{L^p(\mathbb{R})}, \quad (9.1)$$

where u is the harmonic extension of f into the upper half-plane, or the Burkholder–Davis–Gundy inequality for martingales $(f_n)_{n \geq 1}$ in $L^p(\Omega)$, $p \in (1, \infty)$,

$$\|f_N\|_{L^p(\Omega)} \approx \left\| \left(\sum_{n=1}^N |df_n|^2 \right)^{1/2} \right\|_{L^p(\Omega)},$$

where $df_n := f_n - f_{n-1}$ (with $f_0 := 0$) is their difference sequence.

In the present chapter we will present another metamorphosis of square functions which makes it possible to extend them to general Banach spaces. The basic difficulty is that in an abstract Banach space X there is no way to make ‘pointwise evaluations’ of elements to form the L^2 -integrals ‘inside the

norm of X . We overcome this problem by identifying the norm on the right-hand side of (9.1) with the norm of an associated γ -radonifying operator, an idea which carries over to the Banach space setting (as explained in more detail in Section 9.1). In spite of their operator-theoretic definition, these generalised square function norms still behave much like function space norms. Among other things we will prove versions of the dominated convergence theorem, Fatou's lemma, and Fubini's theorem, as well as a multiplier theorem involving operator-valued multipliers whose range is γ -bounded. The 'Hilbert space component' in (9.1), namely the possibility to estimate the norm in (9.1) by applying transformations bounded on $L^2(\mathbb{R}_+)$ to the term $t \frac{\partial}{\partial t} u(t, x)$ as a function of t for fixed values of $x \in \mathbb{R}$, reincarnates in the so-called 'ideal property' of generalised square functions. We also prove various embedding theorems between square function spaces and the classical Sobolev and Hölder spaces.

Throughout this chapter we fix a Hilbert space H with inner product $(\cdot|\cdot)$ and a Banach space X with duality pairing $\langle \cdot, \cdot \rangle$, both over the scalar field \mathbb{K} which may be either \mathbb{R} or \mathbb{C} . Unless stated otherwise, $(\gamma_n)_{n \geq 1}$ will always denote a Gaussian sequence defined on some underlying probability space (Ω, \mathbb{P}) . We remind the reader of the convention that when $\mathbb{K} = \mathbb{R}$, $(\gamma_n)_{n \geq 1}$ is a sequence of independent real-valued standard normal variables and when $\mathbb{K} = \mathbb{C}$, $(\gamma_n)_{n \geq 1}$ is a sequence of independent complex-valued standard normal variables.

9.1 Radonifying operators

Radonifying operators provide the abstract setting to study square functions from an abstract functional analytic point of view. Before turning to the mathematical details, to guide our intuition it will be helpful to explain the heuristics of this approach.

9.1.a Heuristics

We have already seen in the preceding chapters that random sums are often an effective substitute for discrete square functions. Indeed, for any sequence $(x_n)_{n=1}^N$ in $L^p(S)$, $p \in [1, \infty)$, by Proposition 6.3.3 we have

$$\left\| \left(\sum_{n=1}^N |x_n|^2 \right)^{1/2} \right\|_{L^p(S)} \approx \mathbb{E} \left\| \sum_{n=1}^N \gamma_n x_n \right\|_{L^p(S)}. \quad (9.2)$$

For the L^2 -normalised step functions $f : [0, 1] \rightarrow L^p(S)$ of the form

$$f = \sum_{n=1}^N \frac{\mathbf{1}_{(t_{n-1}, t_n)}}{\sqrt{t_n - t_{n-1}}} \otimes x_n,$$

the equivalence of norms (9.2) takes the form

$$\left\| \left(\int_0^1 |f(t, \cdot)|^2 dt \right)^{1/2} \right\|_{L^p(S)} = \left\| \left(\sum_{n=1}^N |x_n|^2 \right)^{1/2} \right\|_{L^p(S)} \approx \mathbb{E} \left\| \sum_{n=1}^N \gamma_n x_n \right\|_{L^p(S)},$$

where $(\gamma_n)_{n=1}^N$ is a Gaussian sequence defined on some probability space. This suggests to define, for step functions f of the above form with values in a Banach space X , the ‘square function norm’ of f by

$$\|f\|_{\gamma(0,1;X)} = \left\| \sum_{n=1}^N \frac{\mathbf{1}_{(t_{n-1}, t_n)}}{\sqrt{t_n - t_{n-1}}} \otimes x_n \right\|_{\gamma(0,1;X)} := \mathbb{E} \left\| \sum_{n=1}^N \gamma_n x_n \right\|. \quad (9.3)$$

This norm ‘replaces’ the orthonormal functions $h_n = \mathbf{1}_{(t_{n-1}, t_n)}/\sqrt{t_n - t_{n-1}}$ by the Gaussian sequence γ_n .

At this point, the reader may wonder why, in (9.2) and (9.3), we choose to use Gaussians rather than Rademachers. After all, since $L^p(S)$ has finite cotype for $p \in [1, \infty)$, the resulting norm would have been equivalent. The reason is that only in this way we ensure that the norm of a simple f in $\gamma(0, 1; X)$ is independent of the chosen representation as a sum of indicators. This depends on the fundamental invariance of the distribution of a Gaussian vector $(\gamma_1, \dots, \gamma_N)$ in \mathbb{K}^N under orthogonal or unitary transformations for $\mathbb{K} = \mathbb{R}$ respectively $\mathbb{K} = \mathbb{C}$. This property distinguishes Gaussian vectors among other possible choices of random variables when we are working with orthonormal sequences in Hilbert spaces (such as the $h_n \in L^2(0, 1)$ in the present discussion).

These considerations suggest, for an arbitrary measure space (S, \mathcal{A}, μ) , to introduce the Banach space $\gamma(S; X)$ as the completion of the μ -simple functions $f : S \rightarrow X$ with respect to the norm

$$\left\| \sum_{n=1}^N \frac{\mathbf{1}_{A_n}}{\sqrt{\mu(A_n)}} \otimes x_n \right\|_{\gamma(S;X)} := \mathbb{E} \left\| \sum_{n=1}^N \gamma_n x_n \right\|,$$

where the sets $A_n \in \mathcal{A}$ are taken disjoint and of finite positive measure. More generally we may define this space as the completion of $L^2(S) \otimes X$ with respect to the norm

$$\left\| \sum_{n=1}^N h_n \otimes x_n \right\|_{\gamma(S;X)}^2 := \mathbb{E} \left\| \sum_{n=1}^N \gamma_n x_n \right\|^2, \quad (9.4)$$

where the h_n are taken orthonormal in $L^2(S)$. Here, as we did before, we interpret $h \otimes x \in L^2(S) \otimes X$ as the function $s \mapsto h(s)x$. We will see below that this norm is indeed the right one to extend the equivalences (9.1)–(9.2) to a large class of Banach spaces.

The key observation now is that the expression on the right of (9.4) makes perfect sense for arbitrary Hilbert spaces H and Banach spaces X , provided

we interpret $\sum_{n=1}^N h_n \otimes x_n$ as the finite rank operator from the dual space H^* into X defined by

$$h^* \mapsto \sum_{n=1}^N \langle h_n, h^* \rangle x_n.$$

In the case of real scalars there is no need to distinguish H and its (Banach) dual H^* and we may use the inner product of H instead. This observation will be the point of departure in this chapter. The space $\gamma(H, X)$ can now be defined as the completion of the space $H \otimes X$ of finite rank operators from H to X with respect to the norm provided by (9.4).

9.1.b The operator spaces $\gamma_\infty(H, X)$ and $\gamma(H, X)$

To start with, we take up the duality issue raised in the last paragraph of the preceding section. When dealing with complex Hilbert spaces and complex Banach spaces simultaneously we have to carefully distinguish between Hilbert space adjoints and Banach space adjoints. The identification of the dual H^* of a Hilbert space H with the space H itself is conjugate-linear rather than linear, and in the context of this chapter the careless identification of H and H^* would lead to the simultaneous consideration of both linear and conjugate-linear operators. The easiest and most elegant way out is to stay, at all times, within the category of Banach spaces. Accordingly, we shall never identify a Hilbert space with its dual, but rather treat Hilbert spaces just as any other Banach space.

The dual H^* of a Hilbert space H has the structure of a Hilbert space in a natural way. Indeed, by the Riesz representation theorem, every $h^* \in H^*$ has the form ψ_h for a unique $h \in H$, where

$$\langle h', \psi_h \rangle := (h' | h), \quad h' \in H.$$

Here $(\cdot | \cdot)$ denotes the inner product of H ; it is bilinear in the case of real Hilbert spaces and linear in the first variable and conjugate-linear in the second variable in the case of complex Hilbert spaces. Now the formula

$$(\psi_{h_1} | \psi_{h_2}) := (h_2 | h_1) \tag{9.5}$$

defines an inner product on H^* . In the case of real Hilbert spaces this is clear, and in the case of complex Hilbert spaces we note that $c\psi_h = \psi_{\bar{c}h}$ implies

$$(c\psi_{h_1} | \psi_{h_2}) = (\psi_{\bar{c}h_1} | \psi_{h_2}) = (h_2 | \bar{c}h_1) = c(h_2 | h_1) = c(\psi_{h_1} | \psi_{h_2})$$

and

$$(\psi_{h_1} | c\psi_{h_2}) = (\psi_{h_1} | \psi_{\bar{c}h_2}) = (\bar{c}h_2 | h_1) = \bar{c}(h_2 | h_1) = \bar{c}(\psi_{h_1} | \psi_{h_2}).$$

Two vectors ψ_{h_1}, ψ_{h_2} are orthonormal in H^* if and only if h_1, h_2 are orthonormal in H . Moreover, for all h in the span of orthonormal vectors h_1, \dots, h_N in H we have the Parseval identity

$$\|h\|^2 = \sum_{n=1}^N |\langle h, \psi_{h_n} \rangle|^2.$$

The space $\gamma_\infty(H, X)$

We begin with a discussion of a somewhat larger space of all γ -summing operators, which appears naturally in results such as the γ -Fatou lemma (Proposition 9.4.6) and the γ -multiplier theorem (Theorem 9.5.1). The space of γ -radonifying operators will be defined as the closure of the finite rank operators in the space of γ -summing operators.

Definition 9.1.1. A linear operator $T : H \rightarrow X$ is called γ -summing if

$$\sup \mathbb{E} \left\| \sum_{j=1}^k \gamma_j Th_j \right\|^2 < \infty,$$

where the supremum is taken over all finite orthonormal systems $\{h_1, \dots, h_k\}$ in H .

With respect to the norm $\|\cdot\|_{\gamma_\infty(H, X)}$ defined by

$$\|T\|_{\gamma_\infty(H, X)}^2 := \sup \mathbb{E} \left\| \sum_{j=1}^k \gamma_j Th_j \right\|^2,$$

the space $\gamma_\infty(H, X)$ of all γ -summing operators from H to X is a normed linear space. By the Kahane-Khintchine inequality, Theorem 6.2.6, we arrive at an equivalent norm if we replace the exponent 2 by any exponent $p \in [1, \infty)$. We shall denote by $\gamma_\infty^p(H, X)$ the space $\gamma_\infty(H, X)$ endowed with this equivalent norm. From now on we consider the exponent $p \in [1, \infty)$ to be fixed.

By considering one-element orthonormal systems $\{h\}$ we see that every γ -summing operator is bounded and satisfies

$$\|\gamma\|_p \|T\| \leq \|T\|_{\gamma_\infty^p(H, X)}. \tag{9.6}$$

In particular, this implies the simple but very useful result that for every $x^* \in X^*$ we have

$$\|T^* x^*\| \leq \|T\| \|x^*\| \leq \|\gamma\|_p^{-1} \|T\|_{\gamma_\infty^p(H, X)} \|x^*\|. \tag{9.7}$$

Proposition 9.1.2. The space $\gamma_\infty(H, X)$ is a Banach space.

Proof. Let $(T_n)_{n \geq 1}$ be Cauchy in $\gamma_\infty(H, X)$. By (9.6), $(T_n)_{n \geq 1}$ is a Cauchy sequence in $\mathcal{L}(H, X)$, and therefore it tends to an operator T in $\mathcal{L}(H, X)$.

Given $\varepsilon > 0$, we choose $N \geq 1$ such that $\|T_n - T_m\|_{\gamma_\infty(H, X)} < \varepsilon$ for all $m, n \geq N$. Let $\{h_1, \dots, h_k\}$ be an orthonormal system in H . By Fatou's lemma, for all $n \geq N$,

$$\mathbb{E} \left\| \sum_{j=1}^k \gamma_j (T_n - T) h_j \right\|^2 \leq \liminf_{m \rightarrow \infty} \mathbb{E} \left\| \sum_{j=1}^k \gamma_j (T_n - T_m) h_j \right\|^2 \leq \varepsilon^2.$$

Therefore, $T_n - T \in \gamma_\infty(H, X)$ and $\|T_n - T\|_{\gamma_\infty(H, X)} \leq \varepsilon$ for all $n \geq N$. This proves that $T \in \gamma_\infty(H, X)$ and that $\lim_{n \rightarrow \infty} T_n = T$ in the norm of $\gamma_\infty(H, X)$. \square

Finite rank operators

For $h^* \in H^*$ and $x \in X$ we denote by $h^* \otimes x$ the rank one operator in $\mathcal{L}(H, X)$ defined by

$$(h^* \otimes x)h := \langle h, h^* \rangle x, \quad h \in H.$$

Under this identification, $H^* \otimes X$ coincides with the space of all finite rank operators in $\mathcal{L}(H, X)$. Every such operator can be represented in the form

$$T = \sum_{n=1}^N h_n^* \otimes x_n \tag{9.8}$$

with $(h_n^*)_{n=1}^N$ orthonormal in H^* and $(x_n)_{n=1}^N$ a sequence in X . Its adjoint $T^* \in \mathcal{L}(X^*, H^*)$ is given by

$$T^* x^* = \sum_{n=1}^N \langle x_n, x^* \rangle h_n^*.$$

In particular, the range of T^* is contained in the span of $(h_n^*)_{n=1}^N$. Conversely, if the range of the adjoint of a bounded operator $T \in \mathcal{L}(H, X)$ is contained in the span of a finite sequence $(h_n^*)_{n=1}^N$, then T vanishes on the pre-annihilator ${}^\perp(h_n^*)_{n=1}^N = \{h \in H : \langle h, h_n^* \rangle = 0, n = 1, \dots, N\}$ which has finite co-dimension in H , and therefore $T \in H^* \otimes X$.

It is a simple observation that every finite rank operator from H to X belongs to $\gamma_\infty(H, X)$, and its norm can be determined as follows.

Proposition 9.1.3 (Exchanging orthonormal sequences with Gaussians). *If $T = \sum_{n=1}^N h_n^* \otimes x_n$ is a finite rank operator with h_1^*, \dots, h_N^* orthonormal in H^* and $x_1, \dots, x_N \in X$, then $T \in \gamma_\infty(H, X)$ and for all $1 \leq p < \infty$ we have*

$$\left\| \sum_{n=1}^N h_n^* \otimes x_n \right\|_{\gamma_\infty^p(H, X)} = \left\| \sum_{n=1}^N \gamma_n x_n \right\|_{L^p(\Omega; X)}. \tag{9.9}$$

Proof. Let $u_1, \dots, u_M \in H$ be an orthonormal system. Let A be the $M \times N$ matrix given by $a_{mn} = \langle u_m, h_n^* \rangle$. It is easily checked that $\|A\| \leq 1$ and therefore, by Proposition 6.1.23,

$$\left\| \sum_{m=1}^M \gamma_m T u_m \right\|_{L^p(\Omega; X)} = \left\| \sum_{m=1}^M \gamma_m \sum_{n=1}^N a_{mn} x_n \right\|_{L^p(\Omega; X)} \leq \left\| \sum_{n=1}^N \gamma_n x_n \right\|_{L^p(\Omega; X)}.$$

This shows that $T \in \gamma_\infty(H, X)$ and that the estimate ‘ \leq ’ in (9.9) holds.

To prove the reverse inequality ‘ \geq ’ in (9.9), let $h = \{h_1, \dots, h_N\}$ be the orthonormal system in H determined by the condition $h_n^* = \psi_{h_n}$ as in (9.5). Then

$$\|T\|_{\gamma_\infty^p(H, X)} \geq \left\| \sum_{n=1}^N \gamma_n T h_n \right\|_{L^p(\Omega; X)} = \left\| \sum_{n=1}^N \gamma_n x_n \right\|_{L^p(\Omega; X)}.$$

□

Note that for $p = 2$ we recover the identity (9.4).

The estimate ‘ \leq ’ of Proposition 9.1.3 can be alternatively deduced from covariance domination. Indeed, let $u_1, \dots, u_M \in H$ be an orthonormal system. Then, for all $x^* \in X^*$,

$$\begin{aligned} \sum_{m=1}^M |\langle T u_m, x^* \rangle|^2 &= \sum_{m=1}^M \left| \sum_{n=1}^N \langle u_m, h_n^* \rangle \langle x_n, x^* \rangle \right|^2 \\ &= \sum_{m=1}^M \left| \left\langle u_m, \sum_{n=1}^N \langle x_n, x^* \rangle h_n^* \right\rangle \right|^2 \\ &\leq \left\| \sum_{n=1}^N \langle x_n, x^* \rangle h_n^* \right\|_{H^*}^2 = \sum_{n=1}^N |\langle x_n, x^* \rangle|^2. \end{aligned}$$

Therefore, by Theorem 6.1.25,

$$\mathbb{E} \left\| \sum_{m=1}^M \gamma_m T u_m \right\|^p \leq \mathbb{E} \left\| \sum_{n=1}^N \gamma_n x_n \right\|^p.$$

The space $\gamma(H, X)$

In Proposition 9.1.3 we have seen that every finite rank operator from H to X belongs to $\gamma_\infty(H, X)$.

Definition 9.1.4. The space $\gamma(H, X)$ is defined as the closure of the finite rank operators in $\gamma_\infty(H, X)$. The operators in $\gamma(H, X)$ are called γ -radonifying.

We shall denote by $\gamma^p(H, X)$ the space $\gamma(H, X)$ endowed with the equivalent norm inherited from $\gamma_\infty^p(H, X)$. Thus, $\gamma(H, X) = \gamma^2(H, X)$. In Theorem 9.1.20 we will show that if X does not contain a closed subspace isomorphic to c_0 , then $\gamma_\infty(H, X) = \gamma(H, X)$. In general, however, $\gamma(H, X)$ is a proper closed subspace of $\gamma_\infty(H, X)$.

It is immediate from the above definition that $H^* \otimes X$ is dense in $\gamma(H, X)$. By Proposition 9.1.3, for any finite rank operator in $H^* \otimes X$ of the form (9.8) we have

$$\left\| \sum_{n=1}^N h_n^* \otimes x_n \right\|_{\gamma^p(H, X)}^p = \mathbb{E} \left\| \sum_{n=1}^N \gamma_n x_n \right\|^p. \tag{9.10}$$

Example 9.1.5. The spaces $\gamma^p(\ell_N^2, X)$ and $\gamma^p(\ell^2, X)$ are naturally isometric to the spaces $\gamma_N^p(X)$ and $\gamma^p(X)$ which have been introduced in Section 6.3.

Non-trivial examples of γ -radonifying operators will be given at several places in this chapter. Among other things, it will be shown that if \tilde{H} is another Hilbert space, then $\gamma(H, \tilde{H})$ coincides with the space of Hilbert-Schmidt operators from H to \tilde{H} , and that if $X = L^p(\nu)$, then we have a canonical isomorphism

$$\gamma(H, L^p(\nu)) \simeq L^p(\nu; H^*).$$

Proposition 9.1.6. *Every operator $T \in \gamma(H, X)$ is compact.*

Proof. By the definition of $\gamma(H, X)$, there exist finite rank operators $T_n \in H^* \otimes X$ such that $\lim_{n \rightarrow \infty} T_n = T$ in $\gamma(H, X)$. Each operator T_n is compact and by (9.6) we have $\lim_{n \rightarrow \infty} T_n = T$ in $\mathcal{L}(H, X)$. Therefore T , being the uniform limit of a sequence of compact operators, is compact. \square

The next result shows that every $T \in \gamma(H, X)$ is ‘supported’ on a separable closed subspace of H . This fact will be used repeatedly to reduce considerations to separable Hilbert spaces.

Proposition 9.1.7. *If $T \in \gamma(H, X)$, then $(N(T))^\perp$ is separable.*

Proof. Suppose that $T = \lim_{n \rightarrow \infty} T_n$ in $\gamma(H, X)$ where each T_n has finite rank, say $T_n h = \sum_{j=1}^{k_n} \langle h, h_{jn}^* \rangle x_{jn}$. Let H_0 denote the closure of the linear span of all vectors h_{jn} , $n \geq 1$, $1 \leq j \leq k_n$, where $h_{jn}^* = \psi_{h_{jn}}$ according to the Riesz representation theorem (see (9.5)). Then H_0 is separable. If $h \perp H_0$, then $T_n h = 0$ for all $n \geq 1$ and consequently $Th = 0$. It follows that $H_0^\perp \subseteq N(T)$, and from this we obtain $(N(T))^\perp \subseteq (H_0^\perp)^\perp = H_0$. \square

Hilbert-Schmidt operators

When K is a Hilbert space, the space $\gamma(H, K)$ coincides with the space of all Hilbert-Schmidt operators from H to K . For the convenience of the reader we recall the definition of these operators; for the details we refer to Appendix D.

Definition 9.1.8. *A linear operator $T : H \rightarrow K$ is called a Hilbert-Schmidt operator if*

$$\sup \sum_{j=1}^k \|Th_j\|^2 < \infty,$$

where the supremum is taken over all finite orthonormal systems $\{h_1, \dots, h_k\}$ in H .

With respect to the norm

$$\|T\|_{\mathcal{C}^2(H,K)} := \sup \left(\sum_{j=1}^k \|Th_j\|^2 \right)^{1/2},$$

the space $\mathcal{C}^2(H, K)$ of all Hilbert–Schmidt operators from H to K is a Hilbert space. If $T \in \mathcal{C}^2(H, K)$ and $(h_i)_{i \in I}$ is a maximal orthonormal system in H , then

$$\sum_{i \in I} \|Th_i\|^2 = \|T\|_{\mathcal{C}^2(H,K)}^2.$$

The bound ‘ \leq ’ is immediate from the definition of the sum as the supremum of its finite sub-sums. For the estimate ‘ \geq ’ one may first observe that the left side is actually independent of the chosen maximal orthonormal system, and then note that any finite orthonormal system can be completed to a maximal orthonormal system.

A direct consequence of the above observation is that there can be at most countably many $i \in I$ for which $Th_i \neq 0$. It follows that T is supported on the separable closed subspace spanned by these h_i . Let us label them as h_{i_1}, h_{i_2}, \dots and denote by P_N the orthogonal projection onto the span of the first N vectors. Then TP_N has finite rank, and

$$\begin{aligned} \|TP_N - T\|^2 &= \sup_{\|h\| \leq 1} \|TP_N h - Th\|^2 \\ &= \sup_{\|h\| \leq 1} \left\| \sum_{n=N+1}^{\infty} (h|h_{i_n})Th_{i_n} \right\|^2 \\ &\leq \sup_{\|h\| \leq 1} \sum_{n=N+1}^{\infty} |h|h_{i_n}|^2 \sum_{n=N+1}^{\infty} \|Th_{i_n}\|^2 \leq \sum_{n=N+1}^{\infty} \|Th_{i_n}\|^2. \end{aligned}$$

As the right-hand side tends to 0, this shows that $\lim_{N \rightarrow \infty} \|TP_N - T\| = 0$. In particular, T is compact. This shows that the definition of a Hilbert-Schmidt operator given here coincides with the one given in Appendix D.

Proposition 9.1.9 (Operators into Hilbert spaces). *Let H and K be Hilbert spaces. Then $T \in \gamma(H, K)$ if and only if $T \in \mathcal{C}^2(H, K)$, and in this case we have*

$$\|T\|_{\gamma(H,K)} = \|T\|_{\mathcal{C}^2(H,K)}.$$

Proof. Let $T \in \mathcal{L}(H, K)$, and let h_1, \dots, h_N be any finite orthonormal system in H . Then

$$\mathbb{E} \left\| \sum_{n=1}^N \gamma_n Th_n \right\|^2 = \mathbb{E} \sum_{m,n=1}^N \gamma_m \bar{\gamma}_n (Th_m | Th_n) = \sum_{n=1}^N \|Th_n\|^2.$$

Taking the supremum over all finite orthonormal systems, the left-hand side becomes $\|T\|_{\gamma_\infty(H,K)}^2$ while the right-hand side gives $\|T\|_{\mathcal{C}^2(H,K)}^2$, and this shows that $\gamma_\infty(H,K) = \mathcal{C}^2(H,K)$ with equal norms. Since finite-rank operators are dense in $\mathcal{C}^2(H,K)$, they are dense in $\gamma_\infty(H,K)$, and so these spaces coincide with $\gamma(H,K)$. \square

9.1.c The ideal property

In this section we prove the so-called ideal property, which arguably is the single most important property of the spaces $\gamma_\infty(H,X)$ and $\gamma(H,X)$. It asserts that both spaces are closed under left and right multiplication by Banach space operators and Hilbert space operators, respectively. As we shall see, this property provides a very powerful tool to study the structure of operators in $\gamma_\infty(H,X)$ and $\gamma(H,X)$.

Theorem 9.1.10 (Ideal property). *Let $T \in \gamma_\infty(H,X)$. If G is another Hilbert space and Y another Banach space, then for all $S \in \mathcal{L}(G,H)$ and $U \in \mathcal{L}(X,Y)$ we have $UTS \in \gamma_\infty(G,Y)$ and for all $1 \leq p < \infty$ we have*

$$\|UTS\|_{\gamma_\infty^p(G,Y)} \leq \|U\| \|T\|_{\gamma_\infty^p(H,X)} \|S\|.$$

If moreover $T \in \gamma(H,X)$, then $UTS \in \gamma(G,Y)$.

Proof. Let $(g_m)_{m=1}^M$ be an orthonormal system in G and let $(h_n)_{n=1}^N$ in H be an orthonormal basis for the span of $\{Sg_m : 1 \leq m \leq M\}$. Let A be the $M \times N$ matrix with coefficients $a_{mn} = (Sg_m|h_n)$. From $Sg_m = \sum_{n=1}^N a_{mn}h_n$ one easily deduces that $\|A\| \leq \|S\|$. It follows from Proposition 6.1.23 that

$$\begin{aligned} \left\| \sum_{m=1}^M \gamma_m UTSg_m \right\|_{L^p(\Omega;Y)} &= \left\| U \sum_{m=1}^M \gamma_m \sum_{n=1}^N a_{mn} Th_n \right\|_{L^p(\Omega;Y)} \\ &\leq \|U\| \|A\| \left\| \sum_{n=1}^N \gamma_n Th_n \right\|_{L^p(\Omega;Y)} \\ &\leq \|U\| \|S\| \|T\|_{\gamma_\infty^p(H,X)}. \end{aligned}$$

Hence $UTS \in \gamma_\infty(G,Y)$ and the required estimate follows.

Next assume that $T \in \gamma(H,X)$. Choose finite rank operators $(T_n)_{n \geq 1}$ such that $T_n \rightarrow T$ in $\gamma(H,X)$. Then, by the estimate just proved,

$$\begin{aligned} \|UT_nS - UTS\|_{\gamma_\infty^p(G,Y)} &= \|U(T_n - T)S\|_{\gamma_\infty^p(G,Y)} \\ &\leq \|U\| \|T_n - T\|_{\gamma_\infty^p(H,X)} \|S\|, \end{aligned}$$

the right-hand side of which tends to zero as $n \rightarrow \infty$. Since each UT_nS is a finite rank operator, the result follows. \square

Example 9.1.11 (Restriction). If $T \in \gamma(H, X)$, then for every closed subspace $G \subseteq H$ we have $T|_G \in \gamma(G, X)$ and

$$\|T|_G\|_{\gamma^p(G, X)} \leq \|T\|_{\gamma^p(H, X)}.$$

This is immediate from the definitions, but it also follows from the right ideal property applied to the inclusion mapping from G to H .

Example 9.1.12 (Null extension). Suppose that we have an orthogonal decomposition $H = H_0 \oplus H_1$. If $T \in \gamma(H_0, X)$, then $T \oplus 0 \in \gamma(H, X)$ and

$$\|T \oplus 0\|_{\gamma^p(H, X)} = \|T\|_{\gamma^p(H_0, X)}.$$

Indeed, letting $P : H \rightarrow H_0$ be the orthogonal projection, the first assertion along with the inequality $\|T \oplus 0\|_{\gamma^p(H, X)} \leq \|T\|_{\gamma^p(H_0, X)}$ follows from the right ideal property. The reverse inequality follows from the previous example.

These examples are also valid for $\gamma_\infty(H, X)$. In the next example we specialise the previous two examples to $H = L^2(S)$.

Example 9.1.13. Let (S, \mathcal{A}, μ) be a measure space and fix a set $A \in \mathcal{A}$. For a bounded operator $T : L^2(S) \rightarrow X$ we may define the ‘restriction of T to A ’ as the operator $R_A T \in \mathcal{L}(L^2(A), X)$ given by

$$(R_A T)f := T(E_A f), \quad f \in L^2(A),$$

where $E_A : L^2(A) \rightarrow L^2(S)$ is the extension operator. Then $T \in \gamma(S; X)$ implies $R_A T \in \gamma(A; X)$ and $\|R_A T\|_{\gamma(A; X)} \leq \|T\|_{\gamma(S; X)}$.

Similarly for a bounded operator $T : L^2(A) \rightarrow X$ we may define the ‘extension of T from A to S ’ as the operator $E_A T \in \mathcal{L}(L^2(S), X)$ given by

$$E_A T f := T(R_A f), \quad f \in L^2(S),$$

where $R_A : L^2(S) \rightarrow L^2(A)$ is the restriction operator. Then $T \in \gamma(A; X)$ if and only if $E_A T \in \gamma(S; X)$, in which case we have $\|E_A T\|_{\gamma(S; X)} = \|T\|_{\gamma(A; X)}$.

9.1.d Convergence results

We have seen that γ -radonification of operators is preserved by left and right multiplication. Our next result considers the situation where we multiply with convergent sequences of operators.

Theorem 9.1.14. *Let G be another Hilbert space and let Y be another Banach space. Let $T \in \gamma(H, X)$. Let S, S_1, S_2, \dots in $\mathcal{L}(G, H)$ and U, U_1, U_2, \dots in $\mathcal{L}(X, Y)$ be such that*

- (i) $\lim_{n \rightarrow \infty} S_n^* h^* = S^* h^*$ for all $h^* \in \overline{\mathbb{R}(T^*)}$,
- (ii) $\lim_{n \rightarrow \infty} U_n x = Ux$ for all $x \in \overline{\mathbb{R}(T)}$.

Then $\lim_{n \rightarrow \infty} U_n T S_n = U T S$ in $\gamma(G, Y)$.

Proof. Let P be the orthogonal projection from H onto $\overline{\mathbf{R}(T^*)} = \mathbf{N}(T)^\perp$. Let $X_0 = \mathbf{R}(T)$. Replacing S_n and S by $P S_n$ and $P S$, and U_n and U by $U_n|_{X_0}$ and $U|_{X_0}$, we see that (i) and (ii) can be replaced by

- (i)' $\lim_{n \rightarrow \infty} S_n^* h^* = S^* h^*$ for all $h^* \in H^*$,
- (ii)' $\lim_{n \rightarrow \infty} U_n x = U x$ for all $x \in X$.

The uniform boundedness theorem implies that $\sup_{n \geq 1} \|U_n\| \leq C < \infty$. Hence, by the triangle inequality and the ideal property,

$$\begin{aligned} \|U_n T S_n - U T S\|_{\gamma(G, Y)} &\leq \|U_n T S_n - U_n T S\|_{\gamma(G, Y)} + \|U_n T S - U T S\|_{\gamma(G, Y)} \\ &\leq C \|T(S_n - S)\|_{\gamma(G, X)} + \|(U_n - U)T\|_{\gamma(H, Y)} \|S\|. \end{aligned}$$

Thus we may consider left and right multiplication separately. Moreover, by approximation it suffices to consider finite rank operators T . So let $T = \sum_{m=1}^M h_m^* \otimes x_m$. Then, by the triangle inequality, it remains to prove the result for rank one operators $T = h^* \otimes x$.

To prove the right convergence observe that

$$T(S - S_n) = (S^* - S_n^*) h^* \otimes x.$$

Therefore, by Proposition 9.1.3,

$$\|T \circ (S - S_n)\|_{\gamma(G, X)} = \|x\| \|S^* h^* - S_n^* h^*\|,$$

which tends to zero as $n \rightarrow \infty$.

Next we consider the left convergence. Again by Proposition 9.1.3 we find

$$\|U_n T - U T\|_{\gamma(H, Y)} = \|U_n x - U x\| \|h^*\|,$$

which again tends to zero as $n \rightarrow \infty$. □

Example 9.1.15 (Approximation). Suppose that H is a separable Hilbert space with orthonormal basis $(h_n)_{n \geq 1}$. Let P_n denote the orthogonal projection onto the span of $\{h_1, \dots, h_n\}$. Then for all $T \in \gamma(H, X)$ we have $\lim_{n \rightarrow \infty} T P_n = T$ in $\gamma(H, X)$.

Example 9.1.16 (Strong measurability). Let S be a measure space and H a separable Hilbert space. For a function $\Phi : S \rightarrow \gamma(H, X)$ define $\Phi h : S \rightarrow X$ by $(\Phi h)(s) := \Phi(s)h$ for $h \in H$. The following assertions are equivalent:

- (1) Φ is strongly μ -measurable;
- (2) Φh is strongly μ -measurable for all $h \in H$.

It suffices to prove that (2) implies (1). If $(h_n)_{n \geq 1}$ is an orthonormal basis for H , then with the notation of Example 9.1.15 for all $s \in S$ we have

$$\Phi(s) = \lim_{n \rightarrow \infty} \Phi(s) P_n = \lim_{n \rightarrow \infty} \sum_{j=1}^n (\cdot | h_j) \Phi(s) h_j,$$

with convergence in the norm of $\gamma(H, X)$. The result now follows from the strong μ -measurability of the functions $s \mapsto \Phi(s)h_j$ on the right-hand side.

Testing against an orthonormal basis

We proceed with a characterisation of γ -summing and γ -radonifying operators in terms of orthonormal bases. We formulate the result for separable infinite-dimensional spaces; for finite-dimensional spaces the same result holds with a slightly simpler proof.

Theorem 9.1.17 (Testing against an orthonormal basis). *Let H be separable and let $(h_n)_{n \geq 1}$ be any fixed orthonormal basis for H .*

- (1) *An operator $T \in \mathcal{L}(H, X)$ belongs to $\gamma_\infty(H, X)$ if and only if for some (equivalently, for all) $1 \leq p < \infty$,*

$$\sup_{N \geq 1} \mathbb{E} \left\| \sum_{n=1}^N \gamma_n T h_n \right\|^p < \infty.$$

In this case,

$$\|T\|_{\gamma_\infty^p(H, X)}^p = \sup_{N \geq 1} \mathbb{E} \left\| \sum_{n=1}^N \gamma_n T h_n \right\|^p.$$

- (2) *An operator $T \in \mathcal{L}(H, X)$ belongs to $\gamma(H, X)$ if and only if for some (equivalently, for all) $1 \leq p < \infty$,*

$$\sum_{n \geq 1} \gamma_n T h_n \text{ converges in } L^p(\Omega; X).$$

In this case, the sum converges almost surely and

$$\|T\|_{\gamma^p(H, X)}^p = \mathbb{E} \left\| \sum_{n \geq 1} \gamma_n T h_n \right\|^p.$$

Proof. (1): We only need to prove the ‘if’ part. Let $\{h'_1, \dots, h'_k\}$ be an orthonormal system in H . Then we can write $h'_j = \sum_{n \geq 1} a_{jn} h_n$ with $a_{jn} = \langle h'_j, h_n \rangle$. For each N the $k \times N$ matrix A_N with coefficients $(a_{jn})_{j,n=1}^{k,N}$ satisfies $\|A_N\| \leq 1$. It follows from Fatou’s lemma and Proposition 6.1.23 that

$$\mathbb{E} \left\| \sum_{j=1}^k \gamma_j T h'_j \right\|^p \leq \liminf_{N \rightarrow \infty} \mathbb{E} \left\| \sum_{j=1}^k \gamma_j \sum_{n=1}^N a_{jn} T h_n \right\|^p \leq \sup_{N \geq 1} \mathbb{E} \left\| \sum_{n=1}^N \gamma_n T h_n \right\|^p.$$

It follows that

$$\|T\|_{\gamma_\infty^p(H, X)}^p \leq \sup_{N \geq 1} \mathbb{E} \left\| \sum_{n=1}^N \gamma_n T h_n \right\|^p.$$

The reverse estimate trivially holds and the proof of (1) is complete.

(2): Let P_n denote the orthogonal projection in H onto the linear span of $\{h_1, \dots, h_n\}$. By Proposition 9.1.3 for all $m < n$ we have

$$\mathbb{E} \left\| \sum_{j=m+1}^n \gamma_j T h_j \right\|^p = \|TP_n - TP_m\|_{\gamma^p(H, X)}^p. \quad (9.11)$$

To prove the ‘only if’ part, we note that the result of Example 9.1.15 implies if $T \in \gamma(H, X)$, then $\lim_{n \rightarrow \infty} TP_n = T$ in $\gamma(H, X)$ and therefore the right-hand side of (9.11) tends to 0 as $m, n \rightarrow \infty$. This proves the convergence of the sum $\sum_{n \geq 1} \gamma_n T h_n$ in $L^p(\Omega; X)$.

To prove the ‘if’ part, note that the convergence of the sum $\sum_{n \geq 1} \gamma_n T h_n$ and identity (9.11) imply that the sequence of finite rank operators $(TP_n)_{n \geq 1}$ is a Cauchy sequence in $\gamma(H, X)$. Its limit equals T , since $\lim_{n \rightarrow \infty} TP_n h = Th$ for all $h \in H$.

The almost sure convergence follows from Corollary 6.4.4. \square

Remark 9.1.18. Many authors take part (2) as the definition of the space $\gamma(H, X)$. The drawback of this approach, at least on the theoretical side, is that it leads to redundant separability assumptions. On the other hand, in Proposition 9.1.7 we have shown that in the approach taken here, one can always reduce to the separable case. In applications, on the other side, it has the advantage that summability needs to be checked only for one fixed choice of an orthonormal basis. For example, in Corollary 9.1.27 we shall establish the γ -radonification of the indefinite integral $I : L^2(0, 1) \rightarrow C^\alpha[0, 1]$ for all $\alpha \in [0, 1/2)$ by exploiting properties of the Haar basis.

Using the notion of summability developed in Chapter 4 we can prove the following version of the above theorem for general Hilbert spaces H :

Theorem 9.1.19 (Testing against a maximal orthonormal system).

Let H be a Hilbert space with a maximal orthonormal system $(h_i)_{i \in I}$ and let $(\gamma_i)_{i \in I}$ be a family of independent standard Gaussian random variables with the same index set. A bounded operator $T : H \rightarrow X$ belongs to $\gamma(H, X)$ if and only if

$$\sum_{i \in I} \gamma_i T h_i$$

is summable in $L^2(\Omega; X)$. In this situation we have

$$\|T\|_{\gamma(H, X)}^2 = \mathbb{E} \left\| \sum_{i \in I} \gamma_i T h_i \right\|^2.$$

Proof. We begin with the ‘if’ part. Since $\sum_{i \in I} \gamma_i T h_i$ is summable, the set $I_0 = \{i \in I : T h_i \neq 0\}$ is countable. If I_0 is finite, then T has finite rank and the result is clear. Suppose therefore that I_0 is countably infinite, and let $\phi : \mathbb{N} \rightarrow I_0$ be an enumeration. Let $H_0 = \{h_i : i \in I_0\}$. It is immediate from the definition of summability that $\sum_{k \geq 0} \gamma_{\phi(k)} T h_{\phi(k)}$ is convergent. By Theorem 9.1.17 this implies that $T|_{H_0} \in \gamma(H_0, X)$ and

$$\mathbb{E} \left\| \sum_{i \in I} \gamma_i Th_i \right\|^2 = \mathbb{E} \left\| \sum_{i \in I_0} \gamma_i Th_i \right\|^2 = \|T|_{H_0}\|_{\gamma(H_0, X)}^2.$$

Since $T|_{H_0} \oplus 0 = T$ the result and the required norm identity for T follows from Example 9.1.12.

To prove the ‘only if’ part, choose a finite rank operators $T_n : H \rightarrow X$ such that $T_n \rightarrow T$ in $\gamma(H, X)$. The set $I_0 := \bigcup_{n \geq 1} \{i \in I : T_n h_i \neq 0\}$ is countable. Therefore, the linear subspace $H_0 = \overline{\text{span}\{h_i : i \in I_0\}}$ of H is separable. Moreover, since for each $n \geq 1$ and $i \in I \setminus I_0$, $T_n h_i = 0$ we obtain that $Th_i = 0$ for all $i \in I \setminus I_0$. By Example 9.1.11, $T|_{H_0} \in \gamma(H_0, X)$ and hence Theorem 9.1.17 implies that $\sum_{i \in I} \gamma_i Th_i = \sum_{i \in I_0} \gamma_i T|_{H_0} h_i$ is summable in $L^2(\Omega; X)$. \square

9.1.e Coincidence $\gamma_\infty(H, X) = \gamma(H, X)$ when $c_0 \not\subseteq X$

In various situations it is easier to prove that an operator belongs to $\gamma_\infty(H, X)$ than to $\gamma(H, X)$. A typical situation occurs when one uses the γ -multiplier theorem (Theorem 9.5.1 below), which allows one to prove that certain point-wise multipliers $M : S \rightarrow \mathcal{L}(X, Y)$ map $\gamma(L^2(S), X)$ into $\gamma_\infty(L^2(S), Y)$. In such situations one may use the following theorem to obtain that the operator in fact belongs to $\gamma(H, X)$.

Theorem 9.1.20. *Let X be a Banach space that does not contain a closed subspace isomorphic to c_0 . Then $\gamma_\infty(H, X) = \gamma(H, X)$.*

Proof. Let $T \in \gamma_\infty(H, X)$. Let us first the case of a separable Hilbert space H , and let $(h_n)_{n \geq 1}$ be an orthonormal basis for H . Clearly,

$$\sup_{N \geq 1} \left\| \sum_{n=1}^N \gamma_n Th_n \right\|_{L^p(\Omega; X)} < \infty.$$

The theorem of Hoffmann-Jørgensen and Kwapien, or more precisely its Corollary 6.4.12, now implies that $\sum_{n \geq 1} \gamma_n Th_n$ converges in $L^p(\Omega; X)$ and almost surely. By Theorem 9.1.17(2), this implies that $T \in \gamma(H, X)$

Next consider the non-separable case. We claim that there exists a separable closed subspace H_0 of H such that T vanishes on H_0^\perp . To this end let $H_1 := \mathbf{N}(T)$ be the null space of T and let $(h_i)_{i \in I}$ be a maximal orthonormal system for $H_0 := H_1^\perp$. We want to prove that H_0 is separable, i.e., that the index set I is countable. Suppose the contrary. Then there exists an integer $N \geq 1$ such that $\|Th_i\| \geq 1/N$ for uncountably many $i \in I$. Put $J := \{i \in I : \|Th_i\| \geq 1/N\}$. Let $(j_n)_{n \geq 1}$ be any sequence in J with no repeated entries. For all $N \geq 1$ we have

$$\mathbb{E} \left\| \sum_{n=1}^N \gamma_n Th_{j_n} \right\|^2 \leq \|T\|_{\gamma_\infty(H, X)}^2.$$

Hence, by Corollary 6.1.17,

$$\mathbb{E} \left\| \sum_{n=1}^N \varepsilon_n T h_{j_n} \right\|^2 \leq \frac{1}{\|\gamma\|_1^2} \|T\|_{\gamma_\infty(H, X)}^2.$$

This means that the random variables $S_N := \sum_{n=1}^N \varepsilon_n T h_{j_n}$ are bounded in $L^2(\Omega; X)$, and again by Corollary 6.4.12 the sum $\sum_{n \geq 1} \varepsilon_n T h_{j_n}$ converges almost surely. But this is only possible when $\lim_{n \rightarrow \infty} T h_{j_n} = 0$, contradicting the fact that $j_n \in J$ for all $n \geq 1$. This proves the claim.

By the right-ideal property and the result in the separable case $T|_{H_0} \in \gamma_\infty(H_0, X) = \gamma(H_0, X)$. Now the result follows from Example 9.1.12. \square

The assumption that X should not contain an isomorphic copy of c_0 cannot be omitted, as is demonstrated by the next example.

Example 9.1.21. In this example the scalar field is real, but it is straightforward to modify it to the complex setting. We shall prove that the multiplication operator $T : \ell^2 \rightarrow c_0$ defined by

$$T((\alpha_n)_{n \geq 1}) := (\alpha_n / \sqrt{\log(n+1)})_{n \geq 1}$$

is γ -summing but fails to be γ -radonifying.

By the basic Gaussian tail estimate $\mathbb{P}(|\gamma| > t) \leq e^{-t^2/2}$ (see (E.8) and Lemma E.2.17), for all $t > 0$ and any choice of constants $c_n > 0$ we have

$$\mathbb{P} \left\{ \sup_{1 \leq n \leq N} \frac{|\gamma_n|^2}{c_n} > t \right\} \leq \sum_{n=1}^N \mathbb{P}(|\gamma_n|^2 > c_n t) \leq \sum_{n=1}^N e^{-\frac{1}{2} c_n t}.$$

With $c_n = \log(n+1) \geq \log 2$ this gives, for $t > 0$,

$$\mathbb{P} \left\{ \sup_{1 \leq n \leq N} \frac{|\gamma_n|^2}{\log(n+1)} > t \right\} \leq \sum_{n=1}^N e^{-\frac{1}{2} t \log(n+1)}.$$

Integrating over $t > 0$ gives, using the bound above for $t > 4$ and a trivial bound for $t \in [0, 4]$,

$$\begin{aligned} \mathbb{E} \left(\sup_{1 \leq n \leq N} \frac{|\gamma_n|^2}{\log(n+1)} \right) &\leq 4 + \sum_{n=1}^N \int_4^\infty e^{-\frac{1}{2} t \log(n+1)} dt \\ &= 4 + \sum_{n=1}^N \frac{2}{(n+1)^2 \log(n+1)} \leq C < \infty. \end{aligned}$$

Let $(u_n)_{n \geq 1}$ be the standard unit basis of ℓ^2 . Then

$$\sup_{N \geq 1} \mathbb{E} \left\| \sum_{n=1}^N \gamma_n T u_n \right\|_{c_0}^2 = \sup_{N \geq 1} \mathbb{E} \left(\sup_{1 \leq n \leq N} \frac{|\gamma_n|^2}{\log(n+1)} \right) < \infty.$$

Hence by Theorem 9.1.17(1) the operator T is γ -summing.

To prove that T is not γ -radonifying, consider the partial sums $\xi_k := \sum_{n=k}^{2k} \gamma_n T u_n$. By an estimate for the maximum of Gaussian variables, (E.10), we have

$$\mathbb{E} \max_{k \leq n \leq 2k} |\gamma_n|^2 \geq \frac{1}{5} \log(k+1).$$

Therefore, we find that for every $k \geq 1$,

$$\|\xi_k\|_{L^2(\Omega; c_0)}^2 = \mathbb{E} \left(\max_{k \leq n \leq 2k} \frac{|\gamma_n|^2}{\log(n+1)} \right) \geq \frac{5^{-1} \log(k+1)}{\log(k+1)} \geq \frac{1}{5}.$$

Thus the series $\sum_{n \geq 1} \gamma_n T u_n$ fails to converge in $L^2(\Omega; c_0)$, and hence T is not γ -radonifying.

9.1.f Trace duality

In this section we describe a natural pairing between $\gamma(H, X)$ and $\gamma(H^*, X^*)$, the so-called *trace duality*.

Recall from Appendix D that $\mathcal{C}^1(H)$ denotes the Banach space of trace class operators on H . The *trace* $\text{tr}(T)$ of an operator $T \in \mathcal{C}^1(H)$ is defined by

$$\text{tr}(T) = \sum_{i \in I} (T h_i | h_i),$$

where $(h_i)_{i \in I}$ is any maximal orthonormal system in H , and it satisfies

$$|\text{tr}(T)| \leq \|T\|_{\mathcal{C}^1(H)}$$

(see Proposition D.2.5). The careful reader should be warned that Appendix D is written with the implicit convention of a complex inner product that is linear in the *second* variable and conjugate-linear in the first one. Since the opposite convention is in force in this chapter, the formulas from Appendix D should be used with corresponding simple modifications.

Proposition 9.1.22. *For all $T \in \gamma(H, X)$ and $S \in \gamma(H^*, X^*)$ we have $S^*T \in \mathcal{C}^1(H)$ and*

$$|\text{tr}(S^*T)| \leq \|S^*T\|_{\mathcal{C}^1(H)} \leq \|S\|_{\gamma(H^*, X^*)} \|T\|_{\gamma(H, X)}.$$

This result admits an extension to the case $T \in \gamma_\infty(H, X)$ and $S \in \gamma_\infty(H^*, X^*)$; this will be discussed in the Notes.

Proof. Since T and S are both compact (Proposition 9.1.6), S^*T is also compact and hence it has a singular value decomposition (cf. (D.1)):

$$S^*T = \sum_{n \geq 1} \tau_n (\cdot | f_n) g_n$$

where $\tau_1 \geq \tau_2 \geq \dots \geq 0$, and $(f_m)_{m \geq 1}$ and $(g_m)_{m \geq 1}$ are both orthonormal systems in H . Let $(g_n^*)_{n \geq 1}$ be the orthonormal system in H^* defined by $\langle h, g_n^* \rangle = (h|g_n)$. It follows that

$$\begin{aligned} \sum_{n=1}^N \tau_n &= \sum_{n=1}^N \langle S^* T f_n, g_n^* \rangle = \mathbb{E} \left\langle \sum_{n=1}^N \gamma_n T f_n, \sum_{n=1}^N \gamma_n S g_n^* \right\rangle \\ &\leq \|T\|_{\gamma(H, X)} \|S\|_{\gamma(H^*, X^*)}. \end{aligned}$$

Passing to the limit $N \rightarrow \infty$ we infer that $S^* T \in \mathcal{C}^1(H)$ and

$$\|S^* T\|_{\mathcal{C}^1(H)} = \sum_{n \geq 1} \tau_n \leq \|T\|_{\gamma(H, X)} \|S\|_{\gamma(H^*, X^*)}.$$

Finally, the estimate $|\text{tr}(S^* T)| \leq \|S^* T\|_{\mathcal{C}^1(H)}$ is in Proposition D.2.5. □

To obtain a converse we will assume that X is K -convex.

Proposition 9.1.23. *Let X be K -convex and suppose that $Y \subseteq X^*$ is a closed subspace that is norming for X . Let $T \in \mathcal{L}(H, X)$. If for all finite rank operators $S : H^* \rightarrow Y$ we have*

$$|\text{tr}(S^* T)| \leq C \|S\|_{\gamma(H^*, X^*)},$$

then $T \in \gamma(H, X)$ and $\|T\|_{\gamma(H, X)} \leq CK_X^\gamma$, where K_X^γ is the Gaussian K -convexity constant of X .

Two cases of interest are $Y = X^*$, or the case $X = Z^*$ and $Y = Z$, where Z is a given Banach space.

Proof. Fix an orthonormal sequence $(h_n)_{n=1}^N$ in H and a number $\varepsilon > 0$. For any sequence $(x_n^*)_{n=1}^N$ in Y , Proposition 9.1.3 shows that the operator $S := \sum_{n=1}^N h_n \otimes x_n^*$ has norm

$$\|S\|_{\gamma(H^*, X^*)} = \left\| \sum_{n=1}^N \gamma_n x_n^* \right\|_{L^2(\Omega; X^*)}.$$

On the other hand, by the Gaussian version of Corollary 7.4.6 in Section 7.4.e we can pick the sequence $(x_n^*)_{n=1}^N$ in Y so that the above norm is at most 1, while

$$\begin{aligned} \left\| \sum_{n=1}^N \gamma_n T h_n \right\|_{L^2(\Omega; X)} &\leq K_X^\gamma \left| \sum_{n=1}^N \langle T h_n, x_n^* \rangle \right| + \varepsilon \\ &= K_X^\gamma |\text{tr}(S^* T)| + \varepsilon \leq K_X^\gamma C + \varepsilon, \end{aligned}$$

where the last step used the assumption of the proposition. It follows that $T \in \gamma_\infty(H, X)$ and $\|T\|_{\gamma_\infty(H, X)} \leq CK_X^\gamma$.

Finally, by Proposition 7.4.12, K -convex spaces cannot contain an isomorphic copy of c_0 . An appeal to Theorem 9.1.20 therefore shows that $T \in \gamma(H, X)$. □

Theorem 9.1.24 (Trace duality). *For all $S \in \gamma(H^*, X^*)$ the mapping $\phi_S : T \mapsto \text{tr}(S^*T)$ defines an element $\phi_S \in (\gamma(H, X))^*$ of norm*

$$\|\phi_S\| \leq \|S\|_{\gamma(H^*, X^*)}.$$

If X is K -convex, then $\phi : S \mapsto \phi_S$ establishes an isomorphism of Banach spaces

$$\gamma(H^*, X^*) \simeq (\gamma(H, X))^*$$

and for all $S \in \gamma(H^, X^*)$ we have*

$$\|\phi_S\| \leq \|S\|_{\gamma(H^*, X^*)} \leq K_X^\gamma \|\phi_S\|.$$

Proof. The first assertion follows from Proposition 9.1.22. It remains to prove that if X is K -convex, then ϕ is surjective and $\|S\|_{\gamma(H^*, X^*)} \leq K_X^\gamma \|\phi_S\|$.

Let $\Lambda \in (\gamma(H, X))^*$ be given. We claim that the bounded operator $S : H^* \rightarrow X^*$ defined by $\langle x, Sh^* \rangle = \langle h^* \otimes x, \Lambda \rangle$ belongs to $\gamma(H^*, X^*)$ and that

$$\text{tr}(S^*T) = \Lambda(T), \quad T \in \gamma(H, X). \tag{9.12}$$

The identity (9.12) is clear for $T = h^* \otimes x$ and extends to all finite rank operators $T : H \rightarrow X$ by linearity. Moreover, for a finite rank operator $T : H \rightarrow X$ it follows that

$$|\text{tr}(S^*T)| = |\Lambda(T)| \leq \|\Lambda\| \|T\|_{\gamma(H, X)}.$$

Since T was arbitrary, it follows from Proposition 9.1.23 with X replaced by X^* and norming subspace $Y = X$ of X^{**} , that $S \in \gamma(H^*, X^*)$, and

$$\|S\|_{\gamma(H^*, X^*)} \leq K_X^\gamma \|\Lambda\|.$$

Now (9.12) follows by density and continuity. Clearly, this implies $\phi_S = \Lambda$. This completes the proof. \square

9.1.g Interpolation

In this section we discuss complex and real interpolation of the spaces $\gamma(H, X)$ assuming that X is K -convex. The discrete case has already been treated in Theorem 7.4.16. We use the notation of Appendix C; in particular we recall that the real interpolation space $(X_0, X_1)_{\theta, p_0, p_1} = (X_0, X_1)_{\theta, p_0, p_1}$ coincides with $(X_0, X_1)_{\theta, p}$ with equivalent norms when $\frac{1}{p} = \frac{1-\theta}{p_0} + \frac{\theta}{p_1}$ (see Theorem C.3.14).

Theorem 9.1.25. *Let H be a Hilbert space and let (X_0, X_1) be an interpolation couple of Banach spaces, and assume that both X_0 and X_1 are K -convex. Let $\theta \in (0, 1)$ and $p_0, p_1, p \in (1, \infty)$ satisfy $\frac{1}{p} = \frac{1-\theta}{p_0} + \frac{\theta}{p_1}$. Then:*

(1) we have $[\gamma^{p_0}(H, X_0), \gamma^{p_1}(H, X_1)]_\theta = \gamma^p(H, [X_0, X_1]_\theta)$ isometrically, and for all $T \in \gamma^p(H, [X_0, X_1]_\theta)$ we have

$$\begin{aligned} \|T\|_{\gamma^p(H, X_\theta)} &\leq \|T\|_{[\gamma^{p_0}(H, X_0), \gamma^{p_1}(H, X_1)]_\theta} \\ &\leq (K_{p_0, X_0}^\gamma)^{1-\theta} (K_{p_1, X_1}^\gamma)^\theta \|T\|_{\gamma^p(H, [X_0, X_1]_\theta)}. \end{aligned}$$

(2) we have $(\gamma^{p_0}(H, X_0), \gamma^{p_1}(H, X_1))_{\theta, p_0, p_1} = \gamma^p(H, (X_0, X_1)_{\theta, p_0, p_1})$ isometrically, and for all $T \in \gamma^p(H, X_\theta)$ we have

$$\begin{aligned} \|T\|_{\gamma^p(H, (X_0, X_1)_{\theta, p_0, p_1})} &\leq \|T\|_{(\gamma^{p_0}(H, X_0), \gamma^{p_1}(H, X_1))_{\theta, p_0, p_1}} \\ &\leq (K_{p_0, X_0}^\gamma)^{1-\theta} (K_{p_1, X_1}^\gamma)^\theta \|T\|_{\gamma^p(H, X_\theta)}. \end{aligned}$$

In both (1) and (2), the first inequality does not require any K -convexity assumptions.

Proof. (1): For all $\theta \in (0, 1)$ and $q \in [1, \infty)$ we have a continuous embedding $\gamma^q(H, [X_0, X_1]_\theta) \hookrightarrow \gamma^2(H, X_0 + X_1)$. Therefore $[\gamma^{p_0}(H, X_0), \gamma^{p_1}(H, X_1)]_\theta \hookrightarrow \gamma^2(H, X_0 + X_1)$ as well. Since any $T \in \gamma^2(H, X_0 + X_1)$ is supported on a separable closed subspace of H , below it suffices to consider separable H .

We claim that the space of finite rank operators $H \otimes (X_0 \cap X_1)$ is dense in $[\gamma^{p_0}(H, X_0), \gamma^{p_1}(H, X_1)]_\theta$ and $\gamma^p(H, [X_0, X_1]_\theta)$. Indeed, for the former note that by Corollary C.2.8 $\gamma(H, X_0) \cap \gamma(H, X_1)$ is dense in $[\gamma(H, X_0), \gamma(H, X_1)]_\theta$. By using a suitable sequence of finite rank projections $P_n : H \rightarrow H$ (see Example 9.1.15) one obtains that $H \otimes (X_0 \cap X_1)$ is dense in $\gamma(H, X_0) \cap \gamma(H, X_1)$. The density of $H \otimes (X_0 \cap X_1)$ in $\gamma^p(H, X_\theta)$ follows from the density of $H \otimes [X_0, X_1]_\theta$ in $\gamma(H, [X_0, X_1]_\theta)$ and the density of $X_0 \cap X_1$ in $[X_0, X_1]_\theta$ (Corollary C.2.8).

Now the proof of the theorem can be completed in a similar way as in Theorem 7.4.16. Fix an orthonormal basis $(h_n)_{n \geq 1}$ for H . For a Banach space Y and $q \in [1, \infty)$, consider the isometric embedding $R_N : \gamma^q(H, Y) \rightarrow L^q(\Omega; Y)$ by $R_N T = \sum_{n=1}^N \gamma_n T h_n$. If Y is K -convex and $q \in (1, \infty)$, define $E_N : L^q(\Omega; Y) \rightarrow \gamma^q(H, Y)$ by $E_N f = \sum_{n=1}^N h_n \otimes \mathbb{E}(\bar{\gamma}_n \pi_N^\gamma f)$. Then by the Gaussian version of K -convexity (Corollary 7.4.20), we have

$$\|E_N f\|_{\gamma^q(H, Y)} = \|\pi_N^\gamma f\|_{L^q(\Omega; Y)} \leq K_{q, Y}^\gamma \|f\|_{L^q(\Omega; Y)}$$

and thus $\|E_N\|_{\mathcal{L}(L^q(\Omega; Y), \gamma^q(H, Y))} \leq K_{q, Y}^\gamma$. Since $E_N R_N = I$, it follows that

$$\begin{aligned} \|T\|_{[\gamma^{p_0}(H, X_0), \gamma^{p_1}(H, X_1)]_\theta} &= \|E_N R_N T\|_{[\gamma^{p_0}(H, X_0), \gamma^{p_1}(H, X_1)]_\theta} \\ &\leq (K_{p_0, X_0}^\gamma)^{1-\theta} (K_{p_1, X_1}^\gamma)^\theta \|R_N T\|_{[L^{p_0}(\Omega; X_0), L^{p_1}(\Omega; X_1)]_\theta} \\ &= (K_{p_0, X_0}^\gamma)^{1-\theta} (K_{p_1, X_1}^\gamma)^\theta \|R_N T\|_{L^p(\Omega; [X_0, X_1]_\theta)} \\ &= (K_{p_0, X_0}^\gamma)^{1-\theta} (K_{p_1, X_1}^\gamma)^\theta \|T\|_{\gamma^p(H; [X_0, X_1]_\theta)}. \end{aligned}$$

Also,

$$\begin{aligned} \|T\|_{\gamma^p(H,[X_0,X_1]_\theta)} &= \|R_N T\|_{L^p(\Omega;[X_0,X_1]_\theta)} \\ &= \|R_N T\|_{[L^{p_0}(\Omega;X_0),L^{p_1}(\Omega;X_1)]_\theta} \leq \|T\|_{[\gamma^{p_0}(H,X_0),\gamma^{p_1}(H,X_1)]_\theta}; \end{aligned}$$

this inequality does not require any K -convexity assumptions. This completes the proof for complex interpolation. The proof for real interpolation proceeds along the same lines. \square

9.1.h The indefinite integral and Brownian motion

In this subsection we present a classical example of a γ -radonifying operator which is connected to the construction of the Wiener process or Brownian motion. We recall from Section 2.5 the fractional Sobolev norm

$$\|f\|_{W^{\alpha,p}(0,1;X)} := \|f\|_{L^p(0,1;X)} + [f]_{W^{\alpha,p}(0,1;X)},$$

where

$$[f]_{W^{\alpha,p}(0,1;X)} := \left(\int_0^1 \int_0^1 \frac{\|f(t) - f(s)\|^p}{|t - s|^{\alpha p + 1}} ds dt \right)^{1/p}.$$

Proposition 9.1.26 (γ -radonification of the indefinite integral). *Let $0 < \alpha < \frac{1}{2}$ and $1 \leq p < \infty$. The indefinite integral*

$$(Jf)(t) := \int_0^t f(s) ds$$

is γ -radonifying from $L^2(0, 1)$ to $W^{\alpha,p}(0, 1)$.

For the proof (and also for reference in our subsequent considerations), we recall the basic identity

$$\left\| \sum_{n=1}^N a_n \gamma_n \right\|_{L^p(\Omega)} = \|\gamma\|_{L^p(\Omega)} \left(\sum_{n=1}^N |a_n|^2 \right)^{1/2}. \tag{9.13}$$

If (S, \mathcal{A}, μ) be a measure space and $p \in [1, \infty)$, Fubini’s theorem implies that for all $x_1, \dots, x_N \in L^p(S)$, we have

$$\left\| \sum_{n=1}^N \gamma_n x_n \right\|_{L^p(\Omega;L^p(S))} = \|\gamma\|_{L^p(\Omega)} \left\| \left(\sum_{n=1}^N |x_n|^2 \right)^{1/2} \right\|_{L^p(S)}. \tag{9.14}$$

Proof of Proposition 9.1.26. We apply (9.14) to both parts of the Sobolev norm.

Let h_1, \dots, h_N be an orthonormal system in $L^2(0, 1)$. For all $0 \leq s < t \leq 1$,

$$\sum_{n=1}^N |Jh_n(t) - Jh_n(s)|^2 = \sum_{n=1}^N |(h_n | \mathbf{1}_{[s,t]})|^2 \leq \| \mathbf{1}_{[s,t]} \|^2_{L^2(0,1)} = t - s. \tag{9.15}$$

Taking $s = 0$ and using (9.14) we find that

$$\begin{aligned} \mathbb{E} \left\| \sum_{n=1}^N \gamma_n Jh_n \right\|_{L^p(0,1)}^p &= \|\gamma\|_{L^p(\Omega)}^p \int_0^1 \left(\sum_{n=1}^N |Jh_n(t)|^2 \right)^{p/2} dt \\ &\leq \|\gamma\|_{L^p(\Omega)}^p \int_0^1 t^{p/2} dt. \end{aligned}$$

Similarly,

$$\begin{aligned} &\mathbb{E} \left[\sum_{n=1}^N \gamma_n Jh_n \right]_{W^{\alpha,p}(0,1)}^p \\ &= \|\gamma\|_{L^p(\Omega)}^p \int_0^1 \int_0^1 |t-s|^{-\alpha p-1} \left(\sum_{n=1}^N |Jh_n(t) - Jh_n(s)|^2 \right)^{p/2} ds dt \\ &\leq \|\gamma\|_{L^p(\Omega)}^p \int_0^1 \int_0^1 |t-s|^{-\alpha p-1} |t-s|^{p/2} ds dt \\ &= C_{p,\alpha} \|\gamma\|_{L^p(\Omega)}^p, \end{aligned}$$

where we use that $\alpha < 1/2$ to see that the last integral is finite. Taking the supremum over all finite orthonormal systems $\{h_1, \dots, h_N\}$ in $L^2(0, 1)$, the result follows from Theorem 9.1.20. Here we use that $W^{\alpha,p}$ does not contain an isomorphic copy of c_0 , because it has cotype $p \vee 2$. \square

From the last part of the proof one can also deduce that J does not belong to the space $\gamma(0, 1; W^{\frac{1}{2},p}(0, 1))$. Indeed, if $(h_n)_{n \geq 1}$ is an orthonormal basis for $L^2(0, 1)$ we can take the supremum over all $N \geq 1$ in the last estimate and obtain equality in (9.15). Incorporating this into the above computation we find that the sum $\sum_{n=1}^N \gamma_n Jh_n$ diverges in $L^p(\Omega; W^{\frac{1}{2},p}(0, 1))$ as $N \rightarrow \infty$.

For $0 < \alpha < 1$ we define $C^\alpha[0, 1]$ as the space of Hölder continuous functions $f : [0, 1] \rightarrow \mathbb{K}$ of exponent α . This is a Banach space with respect to the norm

$$\|f\|_{C^\alpha[0,1]} := \|f\|_\infty + \sup_{0 \leq s < t \leq 1} \frac{|f(t) - f(s)|}{(t-s)^\alpha}.$$

Corollary 9.1.27. *The indefinite integral is γ -radonifying from $L^2(0, 1)$ to $C^\alpha[0, 1]$ for all $0 < \alpha < \frac{1}{2}$.*

This result follows from Proposition 9.1.26 for large enough p and the well-known Sobolev embedding $W^{\alpha,p}(0, 1) \hookrightarrow C^{\alpha-\frac{1}{p}}[0, 1]$. A more direct argument will be presented below. As a consequence of Proposition 9.1.26 and Theorem 9.1.17 the series $\xi := \sum_{n \geq 1} \gamma_n Jh_n$ converges in $L^p(\Omega; C^\alpha[0, 1])$ for all $\alpha \in [0, 1/2)$ and almost surely in $C^\alpha[0, 1]$, say on a set $\Omega_0 \in \mathcal{A}$ with $\mathbb{P}(\Omega_0) = 1$. Define $B : [0, 1] \times \Omega \rightarrow \mathbb{R}$ by $B(t, \omega) = \xi(\omega)(t)$ when $\omega \in \Omega_0$ and zero otherwise. Then B is a *standard Brownian motion* on $\Omega \times [0, 1]$. Indeed, $B(0, \omega) = 0$ and for $s, t \in [0, 1]$, we have

$$\begin{aligned} \mathbb{E}(B(s, \cdot)B(t, \cdot)) &= \sum_{n \geq 1} (Jh_n)(s)(Jh_n)(t) \\ &= \sum_{n \geq 1} (h_n \mathbf{1}_{[0,s]})(h_n \mathbf{1}_{[0,t]}) = (\mathbf{1}_{[0,s]} \mathbf{1}_{[0,t]}) = \min\{s, t\}. \end{aligned}$$

Moreover, B has α -Hölder continuous paths for each $0 \leq \alpha < 1/2$.

In order to give a direct proof of Corollary 9.1.27 we use a lemma on the almost sure boundedness of Gaussian sequences.

Lemma 9.1.28. *If $(\gamma_n)_{n \geq 1}$ is a Gaussian sequence, then for all $\delta > 1$ we have*

$$\limsup_{n \rightarrow \infty} \frac{|\gamma_n|}{\sqrt{\log(n+1)}} \leq \sqrt{2\delta} \text{ almost surely.}$$

Proof. For all $t > 0$,

$$\mathbb{P}\{|\gamma_n| > t\} = \frac{2}{\sqrt{2\pi}} \int_t^\infty e^{-u^2/2} du \leq \frac{2}{t\sqrt{2\pi}} \int_t^\infty ue^{-u^2/2} du = \frac{2}{t\sqrt{2\pi}} e^{-t^2/2}.$$

Fix $\delta > 1$. For all $n \geq 1$ we have $2\delta \log(n+1) > 1$ and therefore

$$\mathbb{P}\{|\gamma_n| > \sqrt{2\delta \log(n+1)}\} < \sqrt{2/\pi} (n+1)^{-\delta}.$$

The Borel-Cantelli lemma now implies that with probability one, $|\gamma_n| > \sqrt{2\delta \log(n+1)}$ for at most finitely many $n \geq 1$. \square

Let $(h_n)_{n \geq 1}$ be the Haar basis of $L^2(0, 1)$, defined by $h_1 \equiv \mathbf{1}$ and $h_n := \phi_{jk}$ for $n \geq 2$, where $n = 2^j + k$ with $j = 0, 1, 2, \dots$ and $k = 1, \dots, 2^j$, and

$$\phi_{jk} := 2^{j/2} \mathbf{1}_{(\frac{k-1}{2^j}, \frac{k-1/2}{2^j})} - 2^{j/2} \mathbf{1}_{(\frac{k-1/2}{2^j}, \frac{k}{2^j})}.$$

Note that ϕ_{jk} is supported on the interval $[\frac{k-1}{2^j}, \frac{k}{2^j}]$. The sequence $(h_n)_{n \geq 1}$ is orthonormal in $L^2(0, 1)$. To see that $(h_n)_{n \geq 1}$ is a basis in $L^2(0, 1)$, note that if $(h|h_n)_{L^2(0,1)} = 0$ for all $n \geq 1$, then h annihilates all dyadic step functions. Since these step functions are dense in $L^2(0, 1)$ it follows that $h = 0$.

Proof of Corollary 9.1.27. The crux of this proof is to prove the convergence of the sum $\sum_{n \geq 1} \gamma_n Jh_n$, where h_n are the Haar functions introduced above.

By Theorem 9.1.17 and the second part of Theorem 6.4.1 it suffices to prove that the sum $\sum_{n=2}^\infty \gamma_n Jh_n = \sum_{j=0}^\infty \sum_{k=1}^{2^j} \gamma_{2^j+k} J\phi_{jk}$ converges in $C^\alpha[0, 1]$ almost surely.

Step 1 – Let $0 \leq s < t \leq 1$ for the moment and let $j_0 \geq 1$. Let $j_1 \geq 1$ be the unique index such that $2^{-j_1+1} \geq t - s > 2^{-j_1}$ and write

$$\sum_{j=j_0}^\infty \sum_{k=1}^{2^j} |\gamma_{2^j+k}(\omega)| \left| \frac{J\phi_{jk}(t) - J\phi_{jk}(s)}{(t-s)^\alpha} \right|$$

$$\leq \left(\sum_{j=j_0}^{j_0 \vee j_1 - 1} + \sum_{j=j_0 \vee j_1}^{\infty} \right) \sum_{k=1}^{2^j} C(\omega) \sqrt{j} \left| \frac{J\phi_{jk}(t) - J\phi_{jk}(s)}{(t-s)^\alpha} \right| =: (I) + (II),$$

where $C(\omega) := \sup_{j,k} |\gamma_{2^j+k}(\omega)|/\sqrt{j} < \infty$ almost surely by Lemma 9.1.28.

We estimate (I) and (II) separately. As for (I), if $j_1 \leq j_0$, then (I) = 0, so we may assume that $j_0 < j_1$. For all $j_0 \leq j < j_1$, we have $|J\phi_{jk}(t) - J\phi_{jk}(s)| \leq 2^{j/2}(t-s)$; and for all but at most two indices k we have $J\phi_{jk}(t) = J\phi_{jk}(s) = 0$. Since $t-s \approx 2^{-j_1} \leq 2^{-j_0}$ and $\alpha \in (0, \frac{1}{2})$, we obtain

$$\begin{aligned} (I) &\leq C(\omega) \sum_{j=j_0}^{j_1-1} \sum_{k=1}^{2^j} \sqrt{j} \left| \frac{J\phi_{jk}(t) - J\phi_{jk}(s)}{(t-s)^\alpha} \right| \\ &\lesssim C(\omega) \sum_{j=j_0}^{j_1-1} \sqrt{j} \cdot 2^{j/2} (t-s)^{1-\alpha} \\ &\lesssim C(\omega) j_1^{3/2} \cdot 2^{j_1/2} 2^{-j_1(1-\alpha)} = C(\omega) j_1^{3/2} 2^{j_1(\alpha-1/2)} \\ &\lesssim C(\omega) j_0^{3/2} 2^{j_0(\alpha-1/2)}. \end{aligned}$$

As for (II), for all $j \geq j_1$ we have $t-s > 1/2^j$, so t and s belong to different sub-intervals of length $1/2^j$. Therefore, $J\phi_{jk}(t) = J\phi_{jk}(s) = 0$ for all but two indices $k \in \{1, \dots, 2^j\}$, and for these two indices we either have $0 \leq J\phi_{jk}(t) \leq 2^{-j/2-1}$ and $J\phi_{jk}(s) = 0$ or the other way around; in either case $|J\phi_{jk}(t) - J\phi_{jk}(s)| \leq 2^{-j/2-1}$. As a consequence, for almost all $\omega \in \Omega$ we obtain the estimate

$$\begin{aligned} (II) &\leq C(\omega) \sum_{j=j_0 \vee j_1}^{\infty} \sum_{k=1}^{2^j} \sqrt{j} \left| \frac{J\phi_{jk}(t) - J\phi_{jk}(s)}{(t-s)^\alpha} \right| \\ &\lesssim C(\omega) \cdot 2^{\alpha j_1} \sum_{j=j_0 \vee j_1}^{\infty} \sqrt{j} \cdot 2^{-j/2} \lesssim C(\omega) 2^{\alpha j_1} \sqrt{j_0 \vee j_1} 2^{-(j_0 \vee j_1)/2} \\ &\leq C(\omega) \sqrt{j_0 \vee j_1} 2^{(j_0 \vee j_1)(\alpha-1/2)} \lesssim C(\omega) \sqrt{j_0} 2^{j_0(\alpha-1/2)}. \end{aligned}$$

Collecting terms we find, for almost all $\omega \in \Omega$,

$$\sup_{0 \leq s < t \leq 1} \sum_{j=j_0}^{\infty} \sum_{k=1}^{2^j} |\gamma_{2^j+k}(\omega)| \left| \frac{J\phi_{jk}(t) - J\phi_{jk}(s)}{(t-s)^\alpha} \right| \leq C(\omega) j_0^{3/2} 2^{j_0(\alpha-1/2)},$$

and this tends to 0 as $j_0 \rightarrow \infty$, since $\alpha < 1/2$.

Step 2 – For all $0 < t \leq 1$ we have, since $Jf(0) = 0$,

$$|Jf(t)| = \frac{|Jf(t) - Jf(0)|}{t^\alpha} \cdot t^\alpha \leq \sup_{0 < \tau \leq 1} \frac{|Jf(\tau) - Jf(0)|}{\tau^\alpha}.$$

Step 3 – By Steps 1 and 2 the sum $\sum_{j=0}^{\infty} \sum_{k=1}^{2^j} \gamma_{2^j+k} J\phi_{jk}$ converges in $C^\alpha[0, 1]$ almost surely. As we have noticed before, the theorem is a consequence of this fact. \square

9.2 Functions representing a γ -radonifying operator

Let (S, \mathcal{A}, μ) be a measure space. In this section we take a closer look at the spaces $\gamma(H, X)$ and $\gamma_\infty(H, X)$ in the particular case when $H = L^2(S)$. In order to simplify notation we shall write

$$\gamma(S; X) := \gamma(L^2(S), X), \quad \gamma_\infty(S; X) := \gamma_\infty(L^2(S), X).$$

As we have pointed out in the introduction, under the identification of $L^2(S)$ with its Banach space dual we may think of the space $L^2(S) \otimes X$ in two ways: as the space of square integrable functions $f : S \rightarrow X$ with finite-dimensional range in X , or as the space of finite rank operators from $L^2(S)$ to X . The function $h \otimes x$ (with $h \in L^2(S)$ and $x \in X$) then corresponds to the operator defined by

$$(h \otimes x)g := \int_S g(s)h(s)x \, d\mu(s), \quad g \in L^2(S). \tag{9.16}$$

Thus, as an operator, $h \otimes x$ is the operator of integration against the functions $t \mapsto (h \otimes x)(t) = h(t)x$.

9.2.a Definitions and basic properties

The identification (9.16) invites us to think of $\gamma(S; X)$ as a space of X -valued generalised functions (distributions) on S . The immediate question that arises is how to recognise those functions $f : S \rightarrow X$ that define an element of $\gamma(S; X)$.

Definition 9.2.1. *A function $f : S \rightarrow X$ is said to be weakly in L^p if for all $x^* \in X^*$ the function $\langle f, x^* \rangle$ is μ -measurable and belongs to $L^p(S)$.*

Recall from Theorem 1.2.37 that if $f : S \rightarrow X$ is strongly μ -measurable and weakly in L^2 , then for all $g \in L^2(S)$ the function $s \mapsto g(s)f(s)$ is Pettis integrable. It thus makes sense to define the bounded operator

$$\mathbb{I}_f : L^2(S) \rightarrow X, \quad g \mapsto \mathbb{I}_f g := \int_S g(s)f(s) \, d\mu(s),$$

where the integral is well defined in the Pettis sense. We shall call \mathbb{I}_f the *Pettis integral operator* with kernel f . With these notation, (9.16) becomes

$$\mathbb{I}_{(h \otimes x)}g = \int_S g(s)h(s)x \, d\mu(s).$$

Identifying $L^2(S)$ and its dual as usual, the adjoint mapping $\mathbb{I}_f^* : X^* \rightarrow L^2(S)$ is given by $\mathbb{I}_f^* x^* = \langle f, x^* \rangle$. In particular, by (9.7),

$$\|\langle f, x^* \rangle\|_{L^2(S)} \leq \|\mathbb{I}_f\|_{\mathcal{L}(L^2(S), X)} \|x^*\| \leq \|\gamma\|_p^{-1} \|\mathbb{I}_f\|_{\gamma^p(L^2(S), X)} \|x^*\|. \tag{9.17}$$

The following proposition is obvious from the definitions and Corollary 1.1.25, which says that two strongly μ -measurable functions f_1, f_2 coincide μ -almost everywhere as soon as the scalar functions $\langle f_1, x^* \rangle, \langle f_2, x^* \rangle$ coincide almost everywhere for every x^* in a weak* dense subspace of X^* .

Proposition 9.2.2. *Let Y be a weak* dense subspace of X^* . Let $f_1, f_2 : S \rightarrow X$ be strongly μ -measurable and such that for all $x^* \in X^*$ the functions $\langle f_1, x^* \rangle$ and $\langle f_2, x^* \rangle$ belong to $L^2(S)$. Then the following are equivalent:*

- (1) for all $x^* \in Y$, $\langle f_1, x^* \rangle = \langle f_2, x^* \rangle$ almost everywhere;
- (2) $f_1 = f_2$ almost everywhere;
- (3) $\mathbb{I}_{f_1} = \mathbb{I}_{f_2}$.

Definition 9.2.3. *A function $f : S \rightarrow X$ is said to belong to, or be in, $\gamma(S; X)$ (respectively, $\gamma_\infty(S; X)$) if it satisfies the following two conditions:*

- (i) $f : S \rightarrow X$ is strongly μ -measurable and weakly in L^2 ;
- (ii) the Pettis integral operator $\mathbb{I}_f : L^2(S) \rightarrow X$ belongs to $\gamma(S; X)$ (respectively, $\gamma_\infty(S; X)$).

In this situation we write ' $f \in \gamma(S; X)$ ', respectively ' $f \in \gamma_\infty(S; X)$ ', and

$$\|f\|_{\gamma^p(S;X)} := \|\mathbb{I}_f\|_{\gamma^p(S;X)}, \quad \|f\|_{\gamma_\infty^p(S;X)} := \|\mathbb{I}_f\|_{\gamma_\infty^p(S;X)}.$$

The reason for including strong measurability in part 9.2.3 is that then Pettis's theorem (Theorem 1.2.37) applies and guarantees that the Pettis integral operator \mathbb{I}_f is well defined.

By (9.17), for $f \in \gamma_\infty(S; X)$ the following estimate holds:

$$\|\langle f, x^* \rangle\|_{L^2(S)} \leq \|\gamma\|_p^{-1} \|f\|_{\gamma_\infty^p(S;X)} \|x^*\|, \quad x^* \in X^*. \tag{9.18}$$

It follows from Examples 9.1.11 and 9.1.12 that if $A \in \mathcal{A}$, then $f|_A \in \gamma(A; X)$ if and only if $\mathbf{1}_A f \in \gamma(S; X)$ and that

$$\|f|_A\|_{\gamma^p(A;X)} = \|\mathbf{1}_A f\|_{\gamma^p(S;X)}, \quad p \in [1, \infty). \tag{9.19}$$

A similar result holds for $\gamma_\infty(S; X)$.

Example 9.2.4. Let $f = \sum_{n=1}^N h_n \otimes x_n$, where $h_1, \dots, h_N \in L^2(S)$ are orthonormal in $L^2(S)$ and $x_1, \dots, x_N \in X$. Then by Proposition 9.1.3,

$$\|f\|_{\gamma^p(S;X)} = \left\| \sum_{n=1}^N \gamma_n x_n \right\|_{L^p(\Omega;X)}.$$

In particular, for a μ -simple function of the form $f = \sum_{n=1}^N \frac{1}{\sqrt{\mu(A_n)}} \mathbf{1}_{A_n} \otimes x_n$, where the sets $A_n \in \mathcal{A}$ are disjoint with positive finite measure, we have

$$\left\| \sum_{n=1}^N \frac{1}{\sqrt{\mu(A_n)}} \mathbf{1}_{A_n} \otimes x_n \right\|_{\gamma^p(S;X)} = \left\| \sum_{n=1}^N \gamma_n x_n \right\|_{L^p(\Omega;X)}.$$

Proposition 9.2.5 (Density). *μ -simple functions are dense in $\gamma(S; X)$.*

Proof. By the density of finite rank operators in $\gamma(S; X)$ and linearity, it suffices to show that every rank one operator $T = g \otimes x$, where $g \in L^2(S)$ and $x \in X$, can be approximated by operators of the form \mathbb{I}_f , where $f : S \rightarrow X$ is μ -simple.

Choose μ -simple functions $(g_n)_{n \geq 1}$ in $L^2(S)$ such that $\lim_{n \rightarrow \infty} g_n = g$ in $L^2(S)$ and let $f_n := g_n \otimes x$ in $\gamma(S; X)$. Then, by Proposition 9.1.3,

$$\|T - \mathbb{I}_{f_n}\|_{\gamma(S; X)} = \|(g - g_n) \otimes x\|_{\gamma(S; X)} = \|g - g_n\|_{L^2(S)} \|x\|,$$

and the result follows. \square

A refinement of this result will be proved in Proposition 9.2.8 below. The reader should be warned that in general not every operator $T \in \gamma_\infty(L^2(S), X)$ has the form \mathbb{I}_f for some strongly μ -measurable function $f : S \rightarrow X$ that is weakly in L^2 (see Example 9.3.5). However, in the case of a discrete measure space every operator has this form.

Example 9.2.6. Consider an operator $T \in \gamma(\ell^2, X)$ and define $f : \mathbb{N} \rightarrow X$ by $f(n) := Tu_n$, where $(u_n)_{n \geq 1}$ is the standard unit basis of ℓ^2 . Then $T = \mathbb{I}_f$.

The following elementary convergence result will be frequently used to identify a limit of a sequence in $\gamma(S; X)$.

Lemma 9.2.7. *Let $T \in \gamma(S; X)$ and let $(f_n)_{n \geq 1}$ be a sequence of functions in $\gamma(S; X)$. Suppose that $\lim_{n \rightarrow \infty} \mathbb{I}_{f_n} = T$ in $\gamma(S; X)$. Let $f : S \rightarrow X$ be strongly measurable and weakly in $L^2(S)$. If for all $x^* \in X^*$ we have $\langle f_n, x^* \rangle \rightarrow \langle f, x^* \rangle$ almost everywhere, then $T = \mathbb{I}_f$.*

Proof. It suffices to show that for all $x^* \in X^*$ we have $T^*x^* = \langle f, x^* \rangle$.

Fix an element $x^* \in X^*$. By (9.7),

$$\|\langle f_n, x^* \rangle - T^*x^*\|_{L^2(S)} \leq \|\mathbb{I}_{f_n} - T\|_{\gamma(S; X)} \|x^*\|$$

and the latter converges to zero. Therefore, $\langle f_n, x^* \rangle \rightarrow T^*x^*$ in $L^2(S)$. Choosing a subsequence $(f_{n_k})_{k \geq 1}$ such that $\langle f_{n_k}, x^* \rangle \rightarrow T^*x^*$ almost everywhere, it follows that $\langle f, x^* \rangle = T^*x^*$. \square

We conclude with a useful approximation result.

Proposition 9.2.8. *If $f : S \rightarrow X$ belongs to $\gamma(S; X)$, then there exists a sequence of μ -simple functions $f_n : S \rightarrow X$ with the following properties:*

- (1) $f_n \rightarrow f$ in $\gamma(S; X)$;
- (2) $f_n \rightarrow f$ μ -almost everywhere on S .

Proof. We prove the proposition in three steps.

Step 1 – First we consider the case $\mu(S) < \infty$. By normalising μ we may then assume that $\mu(S) = 1$.

Off a set of arbitrarily small measure, the strongly μ -measurable function f belongs to $L^\infty(S; X)$, and an approximation result in this space, stated in Lemma 1.2.19, guarantees that for each $\varepsilon > 0$ there exists a μ -simple function g and a set $B \in \mathcal{A}$ with $\mu(B) > 1 - \varepsilon$ such that $\sup_{s \in B} \|f(s) - g(s)\| < \varepsilon$. We use this observation to find a sequence of μ -simple functions $(f_n)_{n \geq 1}$ and a sequence of measurable sets $(B_n)_{n \geq 1}$ such that

$$\sup_{s \in B_n} \|f_n(s) - f(s)\| < \frac{1}{n} \quad \text{and} \quad \mu(S \setminus B_n) < 2^{-n-1}.$$

Upon replacing B_n by $\bigcap_{j \geq n} B_j$, the sets $(B_n)_{n \geq 1}$ can be taken to be increasing with $\mu(S \setminus B_n) < 2^{-n}$. For each $n \geq 1$, let $(A_{nm})_{m=1}^{M_n}$ be the atoms of the σ -algebra generated by the sets B_1, \dots, B_n and the functions f_1, \dots, f_n . Let

$$P_n f = \sum_{m=1}^{M_n} \mathbf{1}_{A_{nm}} \otimes \frac{1}{\mu(A_{nm})} \int_{A_{nm}} f \, d\mu.$$

The set $B = \bigcup_{n \geq 1} B_n$ satisfies $\mu(B) = 1$. Now fix $s \in B$ and choose an arbitrary $\varepsilon > 0$. Let $N \geq 1$ be so large that $\frac{2}{N} < \varepsilon$ and $s \in B_N$. Fix an arbitrary $n \geq N$ and choose m such that $s \in A_{nm}$. Note that $\|f - f_N\| < 1/N$ on A_{nm} . Then also $\|P_n f - P_n f_N\| < 1/N$ on A_{nm} . But for $n \geq N$ we have $P_n f_N = f_N$ and therefore

$$\|f(s) - P_n f(s)\| \leq \|f(s) - f_N(s)\| + \|P_n f_N(s) - P_n f(s)\| < \frac{1}{N} + \frac{1}{N} < \varepsilon.$$

This shows that $P_n f \rightarrow f$ μ -almost everywhere.

Step 2 – If $\mu(S) = \infty$, Proposition 1.1.15 guarantees that f vanishes off a σ -finite subset of S , so without loss of generality we may assume that μ is σ -finite to begin with. Then we can find a sequence of disjoint sets S_1, S_2, \dots in \mathcal{A} such that $\mu(S_m) < \infty$ and $\bigcup_{m \geq 1} S_m = S$. Applying Step 2 to each set S_m , we find a sequence $(P_{mn} f)_{n \geq 1}$ supported in S_m such that $\lim_{n \rightarrow \infty} P_{mn} f = f$ almost everywhere on S_m . The function $P_n f := \sum_{m=1}^n \mathbf{1}_{S_m} P_{mn} f$ then has the desired properties.

Step 3 – The convergence $P_n f \rightarrow f$ in $\gamma(S; X)$ is a consequence of Theorem 9.1.14 since we may regard the operators as self-adjoint operators in $L^2(S)$ as well and there we have $P_n h = \sum_{m=1}^n \mathbf{1}_{S_m} P_{mn} h \rightarrow h$ in the norm of $L^2(S)$. \square

9.2.b Square integrability versus γ -radonification

Let (S, \mathcal{A}, μ) be a measure space. Recall the notation $\gamma(S; X) := \gamma(L^2(S), X)$ introduced before, where we agreed to say that a function $f : S \rightarrow X$ belongs

to $\gamma(S; X)$ if it is strongly μ -measurable and weakly in L^2 and the associated Pettis integral operator $\mathbb{I}_f : L^2(S) \rightarrow X$ belongs to $\gamma(S; X)$.

We proceed with a characterisation of the functions $f : S \rightarrow K$ in $\gamma(S; K)$ for a Hilbert space K . Somewhat informally, the next result asserts that

$$\gamma(S; K) = L^2(S; K).$$

This is one of the reasons why $\|f\|_{\gamma(S;K)}$ is sometimes called a ‘square function norm’. In Theorems 9.2.10 and 9.2.11 below we will see that one-sided continuous inclusions $L^2(S; X) \hookrightarrow \gamma(S; X)$ and $\gamma(S; X) \hookrightarrow L^2(S; X)$ hold for a Banach space X if X has type 2 and cotype 2, respectively. In Section 9.3 we will see another reason why $\gamma(S; X)$ is called a square function space.

Proposition 9.2.9. *Let (S, \mathcal{A}, μ) be a measure space and let K be a Hilbert space. Then:*

- (1) *if $T \in \gamma(S; K)$, then $T = \mathbb{I}_f$ for a unique $f \in L^2(S; K)$;*
- (2) *if $f : S \rightarrow K$ is strongly measurable and weakly L^2 and $\mathbb{I}_f \in \gamma(S; K)$, then $f \in L^2(S; K)$.*

In this situation we have $\|f\|_{\gamma(S;K)} = \|f\|_{L^2(S;K)}$.

Proof. Let $T : L^2(S) \rightarrow K$ have finite rank, say $T = \sum_{n=1}^N h_n \otimes k_n$ with h_1, \dots, h_N orthonormal in $L^2(S)$. Then for all $g \in L^2(S)$ we have

$$Tg = \sum_{n=1}^N \left(\int_S h_n g \, d\mu \right) k_n,$$

which shows that $T = \mathbb{I}_f$ with $f = \sum_{n=1}^N h_n \otimes k_n$, where now we interpret $h_n \otimes k_n$ as the function $s \mapsto h_n(s)k_n$. Furthermore, by Example 9.2.4 we have

$$\|T\|_{\gamma(S;K)}^2 = \mathbb{E} \left\| \sum_{n=1}^N \gamma_n k_n \right\|^2 = \sum_{n=1}^N \|k_n\|^2 = \|f\|_{L^2(S;K)}^2.$$

Since the finite rank operators are dense in $\gamma(S; K)$ this gives (1). To prove (2) we note that if $\mathbb{I}_f \in \gamma(S; K)$, then by (1) we have $\mathbb{I}_f = \mathbb{I}_g$ for some $g \in L^2(S; K)$. But then for all $k^* \in K^*$ we have $\langle f, k^* \rangle = \mathbb{I}_f^* k^* = \mathbb{I}_g^* k^* = \langle g, k^* \rangle$ and therefore $f = g$ μ -almost everywhere by Corollary 1.1.25. In particular, $f \in L^2(S; K)$. \square

In Proposition 9.2.9 we have seen that $\gamma(S; X) = L^2(S; X)$ isometrically if X is a Hilbert space. In the rest of this subsection we shall investigate the situation for Banach spaces X and we will show that the preceding identity characterises Hilbert spaces.

Recall that $\tau_{p,X}^\gamma$ and $c_{q,X}^\gamma$ denote the Gaussian type p and Gaussian cotype q constants (see Section 7.1.d).

Theorem 9.2.10. *Let X be a Banach space and let (S, \mathcal{A}, μ) be a measure space.*

- (1) *If X has type 2, then the identity mapping $f \otimes x \mapsto f \otimes x$ extends to a continuous embedding $L^2(S; X) \hookrightarrow \gamma(S; X)$. Moreover,*

$$\|f\|_{\gamma(S; X)} \leq \tau_{2, X}^\gamma \|f\|_{L^2(S; X)}, \quad f \in L^2(S; X).$$

- (2) *If $\dim(L^2(S)) = \infty$ and there exists a constant $\tau \geq 0$ such that for all μ -simple functions $f : S \rightarrow X$ we have*

$$\|f\|_{\gamma(S; X)} \leq \tau \|f\|_{L^2(S; X)},$$

then X has type 2 and constant $\tau_{2, X}^\gamma \leq \tau$.

The above result and Theorem 9.2.11 below can be used to give a short proof of Theorem 7.1.20.

Proof. (1): By density it suffices to show that the estimate in (1) holds for every μ -simple function $f := \sum_{n=1}^N |S_n|^{-1/2} \mathbf{1}_{S_n} \otimes x_n$, where $(S_n)_{n=1}^N$ is a disjoint sequence in \mathcal{A} . By Example 9.2.4,

$$\|f\|_{\gamma(S; X)} = \left\| \sum_{n=1}^N \gamma_n x_n \right\|_{L^2(\Omega; X)} \leq \tau_{2, X}^\gamma \left(\sum_{n=1}^N \|x_n\|^2 \right)^{1/2} = \tau_{2, X}^\gamma \|f\|_{L^2(S; X)}.$$

(2): Fix a sequence $(x_n)_{n=1}^N$ in X and choose a sequence of disjoint sets $(S_n)_{n=1}^N$ in \mathcal{A} with $0 < \mu(S_n) < \infty$; the latter is possible since $\dim(L^2(S)) = \infty$. Let $f := \sum_{n=1}^N |S_n|^{-1/2} \mathbf{1}_{S_n} \otimes x_n$ as before. Then

$$\left(\mathbb{E} \left\| \sum_{n=1}^N \gamma_n x_n \right\|^2 \right)^{1/2} = \|f\|_{\gamma(S; X)} \leq \tau \|f\|_{L^2(S; X)} = \tau \left(\sum_{n=1}^N \|x_n\|^2 \right)^{1/2}.$$

□

In Sections 9.7.a and 9.7.b we will show that for Banach spaces with type p certain spaces of smooth functions embed in $\gamma(0, 1; X)$. Moreover, such results characterise the type p property.

The next result is the ‘dual’ version of Theorem 9.2.10 and is proved in the same way.

Theorem 9.2.11. *Let X be a Banach space and let (S, \mathcal{A}, μ) be a measure space.*

- (1) *If X has cotype 2, then the identity mapping $f \otimes x \mapsto f \otimes x$ extends to a continuous embedding $\gamma(S; X) \hookrightarrow L^2(S; X)$ and*

$$\|f\|_{L^2(S; X)} \leq c_{2, X}^\gamma \|f\|_{\gamma(S; X)}, \quad f \in \gamma(S; X).$$

(2) If $\dim(L^2(S)) = \infty$ and there exists a constant c such that for all μ -simple functions $f : S \rightarrow X$ we have

$$\|f\|_{L^2(S;X)} \leq c\|f\|_{\gamma(S;X)},$$

then X has cotype 2 and constant $c_{2,X}^\gamma \leq c$.

We can now prove a converse to Proposition 9.2.9, where it has been observed that $\gamma(S; X) = L^2(S; X)$ isometrically if X is a Hilbert space. This converse asserts, somewhat informally, that if $\gamma(S; X) \simeq L^2(S; X)$, then X is isomorphic to a Hilbert space.

Corollary 9.2.12. *Let X be a Banach space and suppose that $\dim(L^2(S)) = \infty$. If there are constants c and τ such that for all μ -simple functions $f : S \rightarrow X$ we have*

$$c^{-1}\|f\|_{L^2(S;X)} \leq \|f\|_{\gamma(S;X)} \leq \tau\|f\|_{L^2(S;X)},$$

then there exists a Hilbert space H and an isomorphism $J : X \rightarrow H$ such that $\|J\|\|J^{-1}\| \leq c\tau$.

Proof. By Theorems 9.2.10 and 9.2.11, X has type 2 with constant $\tau_{2,X}^\gamma \leq \tau$ and cotype 2 with constant $c_{2,X}^\gamma \leq c$. Therefore, the result follows from Kwapien's theorem (Theorem 7.3.1). \square

One may wonder about the role of the exponent 2 in the above results. The following result shows that the type 2 and cotype 2 properties in both second parts of Theorems 9.2.10 and 9.2.11 already follow under much weaker assumptions.

Theorem 9.2.13. *Let X be a Banach space.*

(1) *If there exists a constant $\tau \geq 0$ such that for all μ -simple functions $f : (0, 1) \rightarrow X$ we have*

$$\|f\|_{\gamma(0,1;X)} \leq \tau\|f\|_{L^\infty(0,1;X)},$$

then X has type 2 and $\tau_{2,X}^\gamma \leq \tau$.

(2) *If there exists a constant $c \geq 0$ such that for all μ -simple functions $f : (0, 1) \rightarrow X$ we have*

$$\|f\|_{L^1(0,1;X)} \leq c\|f\|_{\gamma(0,1;X)},$$

then X has cotype 2 and $c_{2,X}^\gamma \leq c$.

Proof. Let $(x_n)_{n=1}^N$ be a sequence in X with at least one non-zero element. Choose a disjoint sequence $(S_n)_{n=1}^N$ of Borel sets in $(0, 1)$ with

$$|S_n| = \frac{\|x_n\|^2}{\sum_{n=1}^N \|x_n\|^2}$$

and let $f := \sum_{n=1}^N |S_n|^{-1/2} \mathbf{1}_{S_n} \otimes x_n$. In case (1) it follows that

$$\left(\mathbb{E} \left\| \sum_{n=1}^N \gamma_n x_n \right\|^2 \right)^{1/2} = \|f\|_{\gamma(0,1;X)} \leq \tau \|f\|_{L^\infty(0,1;X)} = \tau \left(\sum_{n=1}^N \|x_n\|^2 \right)^{1/2}.$$

In case (2) it follows that

$$\left(\sum_{n=1}^N \|x_n\|^2 \right)^{1/2} = \|f\|_{L^1(0,1;X)} \leq c \|f\|_{\gamma(0,1;X)} = c \left(\mathbb{E} \left\| \sum_{n=1}^N \gamma_n x_n \right\|^2 \right)^{1/2}.$$

□

9.2.c Trace duality and the γ -Hölder inequality

We now specialise the trace duality discussed in Section 9.1.f to $H = L^2(S)$. This leads to an interesting inequality of Hölder type.

Theorem 9.2.14. *Let (S, \mathcal{A}, μ) be a measure space.*

- (1) *If $f : S \rightarrow X$ and $g : S \rightarrow X^*$ belong to $\gamma(S; X)$ and $\gamma(S; X^*)$ respectively, then $\langle f, g \rangle \in L^1(S)$,*

$$\int_S \langle f, g \rangle d\mu = \text{tr}(\mathbb{I}_g^* \mathbb{I}_f),$$

and

$$\|\langle f, g \rangle\|_{L^1(S)} \leq \|f\|_{\gamma(S;X)} \|g\|_{\gamma(S;X^*)}.$$

- (2) *Let X be K -convex and let $Y \subseteq X^*$ be a closed subspace that is norming for X . A strongly measurable and weakly L^2 function $f : S \rightarrow X$ belongs to $\gamma(S; X)$ if and only if*

$$\left| \int_S \langle f, g \rangle d\mu \right| \leq C \|g\|_{\gamma(S;X^*)}$$

for all $g \in L^2(S) \otimes Y$, and in this case we have $\|f\|_{\gamma(S;X)} \leq K_X^\gamma C$.

Proof. We first establish (1) in two steps:

Case of simple functions f and g : We can express f and g in the form

$$f = \sum_{n=1}^N \frac{1}{\sqrt{\mu(S_n)}} \mathbf{1}_{S_n} \otimes x_n \quad \text{and} \quad g = \sum_{n=1}^N \frac{1}{\sqrt{\mu(S_n)}} \mathbf{1}_{S_n} \otimes x_n^*,$$

where $S_n \in \mathcal{A}$ are disjoint with finite positive measure, $x_n \in X$ and $x_n^* \in X^*$. Choose scalars $\epsilon_n \in \mathbb{K}$ of modulus one such that $\epsilon_n \langle x_n, x_n^* \rangle = |\langle x_n, x_n^* \rangle|$. Then

$$\|\langle f, g \rangle\|_{L^1(S)} = \sum_{n=1}^N |\langle x_n, x_n^* \rangle| = \sum_{n=1}^N \langle \epsilon_n x_n, x_n^* \rangle$$

$$\begin{aligned} &\leq \left\| \sum_{n=1}^N \epsilon_n \gamma_n x_n \right\|_{L^2(\Omega; X)} \left\| \sum_{n=1}^N \gamma_n x_n^* \right\|_{L^2(\Omega; X^*)} \\ &= \|f\|_{\gamma(S; X)} \|g\|_{\gamma(S; X)}. \end{aligned}$$

To prove the identity for the trace note that

$$\|\mathbb{I}_g^* \mathbb{I}_f\|_{\mathcal{C}^1(H)} \leq \|f\|_{\gamma(S; X)} \|g\|_{\gamma(S; X^*)}$$

by Proposition 9.1.22. Extending $(\mathbf{1}_{S_n} / \sqrt{\mu(S_n)})_{n=1}^N$ to an orthonormal basis $(h_i)_{i \in I}$ for $L^2(S)$,

$$\int_S \langle f, g \rangle d\mu = \sum_{n=1}^N \langle x_n, x_n^* \rangle = \sum_{i \in I} \langle \mathbb{I}_f h_i, \mathbb{I}_g h_i \rangle = \text{tr}(\mathbb{I}_g^* \mathbb{I}_f).$$

Approximation by simple functions: Suppose that we already know the result for some fixed $g : S \rightarrow X^*$ in $\gamma(S; X^*)$ and for all simple $f : S \rightarrow X$. We deduce the result for the same g and a general $f : S \rightarrow X$ in $\gamma(S; X)$ as follows: By Proposition 9.2.8 we can find simple functions $f_n : S \rightarrow X$ such that $f_n \rightarrow f$ in $\gamma(S; X)$ and μ -almost everywhere. By assumption, we have

$$\|\langle f_m, g \rangle - \langle f_n, g \rangle\|_{L^1(S)} \leq \|f_m - f_n\|_{\gamma(S; X)} \|g\|_{\gamma(S; X^*)} \rightarrow 0$$

as $m, n \rightarrow \infty$. Therefore, $(\langle f_n, g \rangle)_{n \geq 1}$ converges in $L^1(S)$ to a function h , say. On the other hand, we also know that $\langle f_n, g \rangle \rightarrow \langle f, g \rangle$ μ -almost everywhere. Thus in fact $\langle f, g \rangle = h \in L^1(S)$, and hence $\langle f_n, g \rangle \rightarrow \langle f, g \rangle$ in $L^1(S)$. From this convergence as well as from $f_n \rightarrow f$ in $\gamma(S; X)$, (1) easily follows using the trace estimate of Proposition 9.1.22.

Note that simple exchanging the roles of f and g , the same argument also shows that if the result holds for some fixed $f : S \rightarrow X$ in $\gamma(S; X)$ and for all simple $g : S \rightarrow X^*$, then it holds for the same f and a general $g : S \rightarrow X^*$ in $\gamma(S; X^*)$.

Let now g be simple and fixed. Then we know the result when also f is simple, and therefore, by the previous approximation, when f is arbitrary. Then let f be arbitrary and fixed. By what we just said, we know the result when g is simple, and therefore, by the previous approximation, when g is arbitrary. This completes the proof of (1).

(2): We have already proved that the ‘only if part’ holds with constant $C = \|f\|_{\gamma(S; X)}$; K -convexity is not needed here.

To prove the ‘if’ part we assume that X is K -convex. Let $R : L^2(S) \rightarrow X^*$ be a finite rank operator taking values in Y , say $R = \sum_{n=1}^N h_n \otimes x_n^*$ with $(h_n)_{n=1}^N$ orthonormal in $L^2(S)$ and $(x_n^*)_{n=1}^N$ a sequence in Y . Let $g : S \rightarrow Y$ be given by $g(s) = \sum_{n=1}^N h_n(s) x_n^*$. Since $R^* \mathbb{I}_f$ is a finite rank operator on $L^2(S)$ taking its range in the span of $(h_n)_{n=1}^N$, its trace is well defined and given by

$$\operatorname{tr}(R^*\mathbb{I}_f) = \sum_{n=1}^N \langle \mathbb{I}_f h_n, x_n^* \rangle = \sum_{n=1}^N \int_S h_n \langle f, x_n^* \rangle d\mu = \int_S \langle f, g \rangle d\mu.$$

As a consequence, the assumption in (2) gives us

$$|\operatorname{tr}(R^*\mathbb{I}_f)| = \left| \int_S \langle f, g \rangle \mu(s) \right| \leq C \|g\|_{\gamma(S; X^*)} = C \|R\|_{\gamma(S; X^*)},$$

The result now follows from Proposition 9.1.23. □

9.3 Square function characterisations

In this section we show that the norm of $\gamma(H, X)$ has an equivalent square function interpretation when X is a Banach function space with finite cotype. In Section 9.3.a this will be demonstrated for $X = L^p(S)$ and in Section 9.3.b for the general case. Moreover, we will characterise those functions $f : S \rightarrow X$ belonging to $\gamma(S; X)$.

9.3.a Square functions in L^p -spaces

We begin with the concrete case when $X = L^p(S)$ with $p \in [1, \infty)$. We have the following characterisation:

Proposition 9.3.1. *Let $1 \leq p < \infty$. For a bounded operator $T \in \mathcal{L}(H, L^p(S))$ the following assertions are equivalent:*

- (1) $T \in \gamma(H, L^p(S))$;
- (2) $T \in \gamma_\infty(H, L^p(S))$;
- (3) we have

$$\sup \left\| \left(\sum_{n=1}^N |Th_n|^2 \right)^{1/2} \right\|_{L^p(S)} < \infty,$$

where the supremum is over all finite orthonormal systems $\{h_1, \dots, h_N\}$ in H .

In this case,

$$\|T\|_{\gamma^p(H, L^p(S))} = \sup \left\| \left(\sum_{n=1}^N |Th_n|^2 \right)^{1/2} \right\|_{L^p(S)}. \tag{9.20}$$

Proof. The equivalence (1) \Leftrightarrow (2) follows from the more general coincidence of $\gamma(H, X)$ and $\gamma_\infty(H, X)$ whenever X does not contain a copy of c_0 (Theorem 9.1.20); indeed, the space $X = L^p(S)$, having finite cotype (Corollary 7.1.6), cannot contain a copy of c_0 , which has no finite cotype (Corollary 7.1.10).

Taking $x_n = Th_n$ for orthonormal $h_n \in H$ in (9.14) we obtain the equivalence (2) \Leftrightarrow (3) as well as the identity (9.20) for the norms. □

In the case of a separable Hilbert spaces H with orthonormal basis $(h_n)_{n \geq 1}$, we furthermore obtain the identity

$$\|T\|_{\gamma^p(H, L^p(S))} = \|\gamma\|_{L^p(\Omega)} \left\| \left(\sum_{n \geq 1} |Th_n|^2 \right)^{1/2} \right\|_{L^p(S)}. \tag{9.21}$$

Any function $\phi \in L^p(S; H^*)$ defines a bounded operator $T_\phi \in \mathcal{L}(H, L^p(S))$ by the prescription $(T_\phi h)(s) := \langle h, \phi(s) \rangle$. We will show next that $T_\phi \in \gamma(H, L^p(S))$ and that all operators in $\gamma(H, L^p(S))$ have this form. Somewhat informally, the next proposition asserts that the mapping $\phi \mapsto T_\phi$ establishes an isomorphism of Banach spaces

$$L^p(S; H^*) \simeq \gamma(H, L^p(S)).$$

The reason for working with $L^p(S; H^*)$ and duality rather than with $L^p(S; H)$ and the inner product is that presently the mapping $\phi \mapsto T_\phi$ is linear; otherwise this mapping would be conjugate-linear. Over the real scalar field there is of course no difference.

Proposition 9.3.2. *Let $1 \leq p < \infty$. Let $\phi : L^p(S; H^*)$ and define $T \in \mathcal{L}(H, L^p(S))$ by $(Th)(s) = \langle h, \phi(s) \rangle$. Then $T \in \gamma(H, L^p(S))$ and*

$$\|T\|_{\gamma^p(H, L^p(S))} = \|\gamma\|_{L^p(\Omega)} \|\phi\|_{L^p(S; H^*)}. \tag{9.22}$$

Conversely, if $T \in \gamma(H, L^p(S))$, then there exists a unique $\phi : L^p(S; H^)$ such that $(Th)(s) = \langle h, \phi(s) \rangle$ for almost all $s \in S$.*

Proof. Fix a function $\phi \in L^p(S; H^*)$. By strong measurability and the result of Example 9.1.12 we may assume that H^* , and hence H , is separable. In that case the norm in $\gamma^p(H, L^p(S))$ can be calculated using any orthonormal basis $(h_n)_{n \geq 1}$ for H (see Theorem 9.1.17). Let $(h_n^*)_{n \geq 1}$ be the orthonormal basis in H^* determined by the conditions $\langle h_n, h_m^* \rangle = \delta_{m,n}$. Let $I \subseteq \mathbb{N}$ be a finite index set. By (9.14),

$$\left\| \sum_{n \in I} \gamma_n Th_n \right\|_{L^p(\Omega; L^p(S))} = \|\gamma\|_{L^p(\Omega)} \left\| \left(\sum_{n \in I} |\langle h_n, \phi \rangle|^2 \right)^{1/2} \right\|_{L^p(S)}. \tag{9.23}$$

Noting that

$$\left\| \left(\sum_{n \geq 1} |\langle h_n, \phi \rangle|^2 \right)^{1/2} \right\|_{L^p(S)} = \|\phi\|_{L^p(S; H^*)},$$

(9.23) implies that $\sum_{n \geq 1} \gamma_n Th_n$ converges in $L^p(\Omega; L^p(S))$. Taking $I = \{1, \dots, N\}$ and passing to the limit $N \rightarrow \infty$, (9.22) follows as well.

In the converse direction, let $T \in \gamma^p(H; L^p(S))$ be given. By Proposition 9.1.7 we may again assume that H is separable. Let $(h_n)_{n \geq 1}$ be an orthonormal basis of H ; then $\sum_{n \geq 1} \gamma_n Th_n$ converges in $L^p(\Omega; L^p(S))$ by Theorem 9.1.17.

Define $\phi_N \in H^* \otimes L^p(S)$ by $\phi_N := \sum_{n=1}^N h_n^* \otimes Th_n$. Using (9.23) we see that $(\phi_N)_{N \geq 1}$ is a Cauchy sequence in $L^p(S; H^*)$ and therefore it converges to some $\phi \in L^p(S; H^*)$. For all $h \in H$ which belong to the linear span of $(h_n)_{n \geq 1}$ we clearly have $Th = \langle h, \phi \rangle$. This identity extends to general $h \in H$ by approximation. Uniqueness of ϕ follows from Corollary 1.1.25. \square

For $H = L^2(T)$, the above lemma takes the form

$$L^p(S; L^2(T)) \simeq \gamma(T, L^p(S))$$

upon identifying $L^2(S)$ with its Banach space dual by identifying $h \in L^2(S)$ with the functional in $(L^2(S))^*$ given by

$$g \mapsto \int_S gh \, d\mu.$$

The norm of $L^p(S; L^2(T))$ is often called a *square function norm*.

Corollary 9.3.3. *Let (S, \mathcal{A}, μ) be a finite measure space and H a Hilbert space. For all $T \in \mathcal{L}(H, L^\infty(S))$ and $1 \leq p < \infty$ we have $T \in \gamma(H, L^p(S))$ and*

$$\|T\|_{\gamma^p(H, L^p(S))} \leq (\mu(S))^{1/p} \|\gamma\|_{L^p(\Omega)} \|T\|_{\mathcal{L}(H, L^\infty(S))}.$$

Proof. Let $(h_n)_{n=1}^N$ be an orthonormal system in H . Fixing $c \in \ell_N^2$, for μ -almost all $s \in S$ we have

$$\begin{aligned} \left| \sum_{n=1}^N c_n (Th_n)(s) \right| &\leq \left\| \sum_{n=1}^N c_n Th_n \right\|_\infty \\ &\leq \|T\|_{\mathcal{L}(H, L^\infty(S))} \left\| \sum_{n=1}^N c_n h_n \right\|_H = \|T\|_{\mathcal{L}(H, L^\infty(S))} \|c\|_{\ell_N^2}. \end{aligned}$$

Taking the supremum over a countable dense set in the unit ball of ℓ_N^2 we obtain the following estimate, valid for μ -almost all $s \in S$:

$$\left(\sum_{n=1}^N |(Th_n)(s)|^2 \right)^{1/2} \leq \|T\|_{\mathcal{L}(H, L^\infty(S))}.$$

Hence,

$$\left\| \left(\sum_{n=1}^N |Th_n|^2 \right)^{1/2} \right\|_{L^p(S)} \leq \mu(S)^{1/p} \|T\|_{\mathcal{L}(H, L^\infty(S))}.$$

By (9.21) the result follows from this. \square

A neat application of Corollary 9.3.3 is the γ -radonification of Sobolev embeddings.

Example 9.3.4 (Sobolev embeddings). Let $D \subseteq \mathbb{R}^d$ be open with finite Lebesgue measure. If $\alpha > d/2$ and D is regular enough, it is well-known that we have the Sobolev embedding $W^{\alpha,2}(D) \hookrightarrow L^\infty(D)$, and it follows from Corollary 9.3.3 that for all $p \in [1, \infty)$ the embedding

$$W^{\alpha,2}(D) \hookrightarrow L^p(D)$$

is γ -radonifying.

Example 9.3.5 (Weighted indefinite integrals). Let $X = L^p(0, 1)$ with $p \in [1, \infty)$. Let $k : (0, 1) \times (0, 1) \rightarrow \mathbb{K}$ be a measurable function such that

$$\operatorname{ess\,sup}_{t \in (0,1)} \int_0^1 |k(t, s)|^2 \, ds < \infty. \tag{9.24}$$

Let $T : L^2(0, 1) \rightarrow L^p(0, 1)$ be the operator given by

$$(Tg)(t) = \int_0^1 k(t, s)g(s) \, ds. \tag{9.25}$$

Then by Hölder’s inequality $T \in \mathcal{L}(L^2(0, 1), L^\infty(0, 1))$ and therefore $T \in \gamma(0, 1; L^p(0, 1))$ by Corollary 9.3.3.

Incidentally, this example shows that not every operator $T \in \gamma(S; L^p(0, 1))$ has the form \mathbb{I}_f for some strongly measurable function $f : S \rightarrow L^p(0, 1)$. Indeed, let $p \in (2, \infty)$ and $\alpha \in (1/p, 1/2)$ and let $k(t, s) = |t - s|^{-\alpha}$. It is clear that this kernel satisfies (9.24). Now suppose that the operator T defined by (9.25) is of the form $T = \mathbb{I}_f$ for some strongly measurable function $f : (0, 1) \rightarrow L^p(0, 1)$ which is weakly L^2 . Then for all $g \in L^{p'}(0, 1)$ and $h \in L^2(0, 1)$ we have, using that $k(s, t) = k(t, s)$,

$$\int_0^1 \int_0^1 k(t, s)g(s)h(t) \, ds \, dt = \langle Th, g \rangle = \langle h, T^*g \rangle = \langle h, \langle f, g \rangle \rangle.$$

It follows that for almost all $t \in (0, 1)$ we have $(f(s))(t) = k(t, s)$ for almost all $s \in (0, 1)$. But then, after choosing a jointly measurable function representing f , by Fubini’s theorem this implies that, for almost all $s \in (0, 1)$, we have $(f(s))(t) = k(t, s)$ for almost all $t \in (0, 1)$. Hence $\|f(s)\|_{L^p(0,1)} = \infty$ for almost all $s \in (0, 1)$.

This phenomenon cannot occur if X has cotype 2, since for any Banach space X with cotype 2 we have a continuous inclusion $\gamma(0, 1; X) \hookrightarrow L^2(0, 1; X)$ (see Theorem 9.2.11).

9.3.b Square functions in Banach function spaces

Our next aim is to extend the isomorphism

$$L^p(S; H^*) \simeq \gamma^p(H, L^p(S))$$

of Section 9.3.a to the setting where $L^p(S)$ is replaced by an arbitrary Banach function space with finite cotype. For the definition Banach function spaces the reader is referred to Appendix F.

In order to formulate the next result we need the following notation. For a Banach function space $E(S)$ over a measure space (S, \mathcal{A}, μ) and a Banach space X , we denote by $E(S; X)$ the space of all strongly μ -measurable functions $\phi : S \rightarrow X$ for which

$$\|\phi\|_{E(S; X)} := \left\| s \mapsto \|\phi(s)\|_X \right\|_{E(S)}$$

is finite. Arguing in the standard proof of for the completeness of $L^p(S; X)$ -spaces, one easily shows that $E(S; X)$ is a Banach space. In the proof of the next theorem we will need the simple fact that if $f_n \rightarrow f$ in $E(S; X)$, then there exists a subsequence such that $f_{n_k} \rightarrow f$ μ -almost everywhere. As for $L^p(S; X)$ the proof of this fact is a by-product of the completeness proof.

Theorem 9.3.6. *Let $E(S)$ be a Banach function space with finite cotype. Then the mapping $U : E(S; H^*) \rightarrow \mathcal{L}(H, E(S))$ defined by*

$$(Uf)h := \langle h, f(\cdot) \rangle, \quad h \in H,$$

defines an isomorphism of Banach spaces

$$E(S; H^*) \simeq \gamma(H, E(S)).$$

Furthermore, for an operator $T \in \mathcal{L}(H, E(S))$ the following assertions are equivalent:

- (1) $T \in \gamma(H, E(S))$;
- (2) *there exists a function $0 \leq g \in E(S)$ such that for all finite orthonormal systems $(h_n)_{n=1}^N$ we have*

$$\left(\sum_{n=1}^N |Th_n|^2 \right)^{1/2} \leq g \quad \mu\text{-almost everywhere};$$

- (3) *there exists a function $0 \leq g \in E(S)$ such that for all $h \in H$ we have*

$$|Th| \leq \|h\|_H g \quad \mu\text{-almost everywhere};$$

- (4) *there exists a function $k \in E(S; H^*)$ such that for all $h \in H$ we have*

$$Th = \langle h, k(\cdot) \rangle \quad \mu\text{-almost everywhere}.$$

If H is separable with an orthonormal basis $(h_n)_{n \geq 1}$, then we have the further equivalence

(5) The function $(\sum_{n \geq 1} |Th_n|^2)^{1/2}$ belongs to $E(S)$.

In this situation, in (4) we may take $k = (\sum_{n \geq 1} |Th_n|^2)^{1/2}$ and we have

$$\|T\|_{\gamma(H, E(S))} \sim_{E(S)} \|k\|_{E(S; H^*)} = \left\| \left(\sum_{n \geq 1} |Th_n|^2 \right)^{1/2} \right\|_{E(S)}. \tag{9.26}$$

In the proof we will use that for all $x_1, \dots, x_N \in E(S)$ we have

$$\left\| \left(\sum_{n=1}^N |x_n|^2 \right)^{1/2} \right\|_{E(S)} \sim_E \left\| \sum_{n=1}^N \varepsilon_n x_n \right\|_{L^2(\Omega; E(S))} \sim_E \left\| \sum_{n=1}^N \gamma_n x_n \right\|_{L^2(\Omega; E(S))}. \tag{9.27}$$

The first estimate is the Khintchine–Maurey inequality (see Theorem 7.2.13) and the second estimate follows from Corollary 7.2.10.

Proof. Since $E(S)$ has finite cotype, it does not contain a closed subspace isomorphic to c_0 (which fails to have finite cotype by Corollary 7.1.10). Therefore, by Theorem 9.1.20, $\gamma_\infty(H, E(S)) = \gamma(H, E(S))$; this will be used several times below.

(2) \Rightarrow (1): Let $(h_n)_{n=1}^N$ be a finite orthonormal system $(h_n)_{n=1}^N$ in H . By (9.27), applied with $x_n := Th_n$, (2) implies that

$$\mathbb{E} \left\| \sum_{n=1}^N \gamma_n Th_n \right\|_{E(S)}^2 \leq C^2 \|g\|_{E(S)}^2 < \infty.$$

Since this is uniform over all finite orthonormal system in H , this means that $T \in \gamma_\infty(H, E(S))$.

(1) \Rightarrow (3): By Proposition 9.1.7, T is supported on some separable closed subspace H' of H , say with orthonormal basis $(h'_n)_{n \geq 1}$. By a Cauchy sequence argument and letting $N \rightarrow \infty$ in (9.27) with $x_n = Th'_n$, we see that the function $g = (\sum_{n \geq 1} |Th'_n|^2)^{1/2}$ is well defined and belongs to $E(S)$. Now let $h \in H$ be arbitrary and write $h = h' + (h')^\perp$ along the orthogonal decomposition $H = H' \oplus (H')^\perp$. Then

$$\begin{aligned} |Th| &= |Th'| = \left| \sum_{n \geq 1} (h'|h'_n) Th'_n \right| \\ &\leq \left(\sum_{n \geq 1} |(h'|h'_n)|^2 \right)^{1/2} \left(\sum_{n \geq 1} |Th'_n|^2 \right)^{1/2} \leq \|h'\| \|g\| \leq \|h\| \|g\|. \end{aligned}$$

(3) \Rightarrow (4) for separable H : Choose a countable dense set H_0 in H which is closed under taking \mathbb{Q} -linear combinations. Let $N \in \mathcal{A}$ be a μ -null set such that for all $s \in \mathbb{C}N$ and for all $h \in H_0$, $|Th(s)| \leq g(s) \|h\|_H$ and $h \mapsto Th(s)$ is \mathbb{Q} -linear on H_0 . For each fixed $s \in \mathbb{C}N$, the mapping $h \rightarrow Th(s)$ therefore

has a unique extension to an element $k(s) \in H^*$ of norm $\leq g(s)$ with $Th(s) = \langle h, k(s) \rangle$ for all $h \in H_0$. Note that the right-hand side is μ -measurable as a function of s since this is true for the left-hand side. By an approximation argument we obtain that for all $h \in H$ we have $Th(s) = \langle h, k(s) \rangle$ for μ -almost all $s \in S$.

(4) \Rightarrow (2): Let $(h_n)_{n=1}^N$ be an orthonormal sequence in H and let $g = \|k\|_{H^*}$. Let $N \in \mathcal{A}$ be a μ -null set such that for all $s \in \mathbb{C}N$ and all $1 \leq n \leq N$ we have $Th_n(s) = \langle h_n, k(s) \rangle$. Then for $s \in \mathbb{C}N$,

$$\left(\sum_{n=1}^N |Th_n(s)|^2 \right)^{1/2} = \left(\sum_{n=1}^N |\langle h_n, k(s) \rangle|^2 \right)^{1/2} \leq \|k(s)\|_{H^*} = g(s).$$

This gives (2). If H is separable with orthonormal basis $(h_n)_{n \geq 1}$, equality is obtained in the preceding estimate if we pass to the limit $N \rightarrow \infty$. This proves the last identity in (9.26) if H is separable. The first part of (9.26) for separable H follows by taking an orthonormal basis $(h_n)_{n \geq 1}$ for H and letting N tend to infinity in (9.27).

This completes the proofs of (3) \Rightarrow (4) \Rightarrow (2) under the assumption that H is separable.

(3) \Rightarrow (1) for general H : The above argument proves that if (3) holds, then the restriction of T to any separable closed subspace H' of H belongs to $\gamma(H', E(S))$ and satisfies $\|T\|_{\gamma(H', E(S))} \leq C\|g\|_{E(S)}$. This implies that $T \in \gamma_\infty(H, E(S))$ and $\|T\|_{\gamma_\infty(H, E(S))} \leq C\|g\|_{E(S)}$ and (1) follows.

We have now completed the proof of the equivalences (1) \Leftrightarrow (2) \Leftrightarrow (3), and, incidentally, the equivalence of these conditions with (9.3.6).

(1) \Rightarrow (4) for general H : As in the proof of (1) \Rightarrow (3) we may assume that H is separable, and for separable H the proof of all equivalences has already been established. \square

Let (S, \mathcal{A}, μ) and (T, \mathcal{B}, ν) be σ -finite measure spaces and $E(S)$ a Banach function space over (S, \mathcal{A}, μ) . As a variation on an observation in Proposition 1.2.25, the next lemma shows that strongly ν -measurable functions $T \rightarrow E(S)$ can be identified with jointly measurable functions on $T \times S$.

Lemma 9.3.7. *Let (S, \mathcal{A}, μ) and (T, \mathcal{B}, ν) be σ -finite measure spaces. Let $E(S)$ be a Banach function space over (T, \mathcal{B}, ν) . For each strongly μ -measurable function $f : T \rightarrow E(S)$, there exists a jointly $\nu \times \mu$ -measurable function $g : T \times S \rightarrow \mathbb{K}$ such that for ν -almost all $t \in T$ the identity $g(t, s) = f(t)(s)$ holds for μ -almost all $s \in S$.*

Proof. It suffices to consider the case of real scalars. By applying the invertible transformation in the range of our functions, we may assume that $|f(t)(s)| < 1$. By Lemma 2.1.4 we can find a sequence $(f_n)_{n \geq 1}$ of countably valued ν -simple functions such that for ν -almost all $t \in T$, $\|f_n(t)(\cdot) -$

$f(t)(\cdot)\|_{E(S)} < 2^{-n}$. Clearly, the functions $g_n(t, s) = f_n(t)(s)$ can be chosen in a jointly measurable way. Now for ν -almost all $t \in T$,

$$\left\| \sum_{n \geq 1} |f(t)(\cdot) - g_n(t, \cdot)| \right\|_{E(S)} \leq \sum_{n \geq 1} \|f(t)(\cdot) - g_n(t, \cdot)\|_{E(S)} < \infty.$$

Thus for ν -almost all $t \in T$, for μ -almost all $s \in S$ we have $\sum_{n \geq 1} |f(t)(s) - g_n(t, s)| < \infty$. Therefore, by Fubini's theorem, $(g_n)_{n \geq 1}$ converges $\nu \times \mu$ almost everywhere, and we can put $g(t, s) := \lim_{n \rightarrow \infty} g_n(t, s)$ for those (t, s) for which this limit exists and zero otherwise. Clearly, g has the required properties. \square

We will now specialise Theorem 9.3.6 to the case $H = L^2(T)$, identifying $(L^2(T))^* = L^2(T)$ as usual.

Theorem 9.3.8. *Let (S, \mathcal{A}, μ) and (T, \mathcal{B}, ν) be σ -finite measure spaces. Let $E(S)$ be a Banach function space over (S, \mathcal{A}, μ) with finite cotype. For a strongly ν -measurable function $f : T \rightarrow E(S)$, the following assertions are equivalent:*

- (1) $\mathbb{I}_f \in \gamma(L^2(T), E(S))$;
- (2) $f \in E(S; L^2(T))$.

In this case we have $\|\mathbb{I}_f\|_{\gamma(L^2(T), E)} \approx_E \|f\|_{E(S; L^2(T))}$.

Proof. We begin with the observation that in both implications (1) \Rightarrow (2) and (2) \Rightarrow (1) there is no loss of generality in assuming that $L^2(T)$ is separable. Indeed, for the first implication we note that \mathbb{I}_f is separably supported, and this allows us to pass to a μ -countably generated sub- σ -algebra. For the second implication we argue similarly, now using that the strongly measurable functions f is ν -essentially separably valued. This proves our claim. We may therefore fix an orthonormal basis $(h_n)_{n \geq 1}$ in $L^2(T)$ and put

$$x_n := \int_T f(t)h_n(t) \, d\mu(t).$$

By Proposition 1.2.25 we have

$$x_n(s) = \int_T g(t, s)h_n(t) \, d\nu(t)$$

for μ -almost all $s \in S$ and all $n \geq 1$.

Let $g : T \times S \rightarrow \mathbb{K}$ be as in Lemma 9.3.7. Note that $\langle g(t, \cdot), x^* \rangle = \langle f(t), x^* \rangle$ for all $x^* \in E^*(S)$.

(1) \Rightarrow (2): Define

$$f_n(t)(s) := \sum_{k=1}^n h_k(t)x_k(s).$$

By Parseval's identity, for all $0 \leq m \leq n$ we have

$$\begin{aligned} \|f_n - f_m\|_{E(S; L^2(T))} &= \left\| s \mapsto \left(\sum_{k=m+1}^n |x_k(s)|^2 \right)^{1/2} \right\|_{E(S)} \\ &\approx_E \left\| \sum_{k=m+1}^n \gamma_k x_k \right\|_{L^2(\Omega; E(S))}. \end{aligned}$$

By the assumption and Theorem 9.1.17 we know that $\sum_{k=1}^{\infty} \gamma_k x_k$ converges in $L^2(\Omega; E(S))$. Therefore, $(f_n)_{n \geq 1}$ is a Cauchy sequence in $E(S; L^2(T))$. By the completeness of $E(S; L^2(T))$ we find that there exists a function $F \in E(S; L^2(T))$ such that $F = \lim_{n \rightarrow \infty} f_n$ in $E(S; L^2(T))$. Taking an almost everywhere convergent subsequence we find that $f = F$. The final identity follows by taking $m = 0$ and letting $n \rightarrow \infty$.

(2) \Rightarrow (1): Let $f \in E(S; L^2(T))$. We claim that f is weakly in $L^2(T)$. Indeed, let $x^* \in E^*(S)$ with $\|x^*\| \leq 1$ be fixed. Since (T, \mathcal{B}, ν) is σ -finite there is an exhausting sequence for T , i.e., an increasing sequence $(C_m)_{m \geq 1}$ of sets of finite measure whose union covers T . For each $m \geq 1$, let $A_m = \{t \in T : \|f(t)\|_{E(S)} \leq m\} \cap C_m$. Then $\mathbf{1}_{A_m} \langle f(\cdot), x^* \rangle$ belongs to $L^2(T)$ and for all $m, N \geq 1$ and all $h \in L^2(T)$ of norm one we have

$$\begin{aligned} \left| \left\langle h, \mathbf{1}_{A_m} \langle f(\cdot), x^* \rangle \right\rangle \right| &= \left| \left\langle \int_T h(t) \mathbf{1}_{A_m} f(t) \, d\mu(t), x^* \right\rangle \right| \\ &= \left| \left\langle s \mapsto \int_T h(t) \mathbf{1}_{A_m} g(t, s) \, d\mu(t), x^* \right\rangle \right| \\ &= |\langle s \mapsto \langle g(\cdot, s), \mathbf{1}_{A_m} h \rangle, x^* \rangle| \\ &\leq \|s \mapsto \langle g(\cdot, s), \mathbf{1}_{A_m} h \rangle\|_{E(S)} \\ &\leq \|s \mapsto \|g(\cdot, s)\|_{L^2(T)} \|\mathbf{1}_{A_m} h\|_{L^2(T)}\|_{E(S)} \\ &\leq \|s \mapsto \|g(\cdot, s)\|_{L^2(T)}\|_{E(S)} = \|f\|_{E(S; L^2(T))}. \end{aligned}$$

Here we used the fact that for μ -almost all $s \in S$,

$$\left(\int_T \mathbf{1}_{A_m} f(t) h(t) \, d\mu(t) \right)(s) = \int_T \mathbf{1}_{A_m} g(t, s) h(t) \, d\nu(t),$$

which can be seen as in Proposition 1.2.25.

Taking the supremum over all $\|h\| \leq 1$ and letting $m \rightarrow \infty$, we obtain $\| \langle f, x^* \rangle \|_{L^2(T)} \leq \|f\|_{E(S; L^2(T))}$. This proves the claim.

Since f is weakly in L^2 , the operator $\mathbb{I}_f : L^2(T) \rightarrow E(S)$ is bounded. Observe that by Theorem 9.3.6 and Bessel's inequality (applied μ -almost everywhere in S) we have

$$\begin{aligned} \left\| \sum_{n=1}^N \gamma_n x_n \right\|_{L^2(\Omega; E)} &\approx_E \left\| s \mapsto \left(\sum_{n=1}^N |x_n(s)|^2 \right)^{1/2} \right\| \\ &= \left\| s \mapsto \left(\sum_{n=1}^N |\langle g(\cdot, s), h_n \rangle|^2 \right)^{1/2} \right\|_{E(S)} \end{aligned}$$

$$\leq \|s \mapsto \|g(\cdot, s)\|_{L^2(T)}\|_{E(S)} = \|f\|_{E(S;L^2(T))}.$$

It follows that $\mathbb{I}_f \in \gamma_\infty(L^2(T), E(S))$, and since $E(S)$ does not contain a copy of c_0 it follows from Theorem 9.1.20 that $\mathbb{I}_f \in \gamma(L^2(T), E(S))$. \square

9.4 Function space properties

In this section we will prove a number of further results which collectively show that spaces of γ -radonifying operators display many similarities with spaces of (generalised) measurable functions.

9.4.a Convergence theorems

We will show that operator sequences in $\gamma(H, X)$ satisfy convergence criteria analogous to the dominated convergence theorem and Fatou’s lemma from real analysis. We begin with an extension of the covariance domination result of Theorem 6.1.25. Somewhat informally it expresses that an operator that is ‘pointwise’ dominated by a γ -radonifying operator is itself a radonifying operator. This is yet another analogy of the γ -radonifying norm with Banach function space norms, but the pointwise domination in the sense of evaluating functions at every point is replaced by the application of the adjoint operators on every vector in the dual space.

Theorem 9.4.1 (Domination). *Let H_1 and H_2 be Hilbert spaces and let $T_1 \in \mathcal{L}(H_1, X)$ and $T_2 \in \mathcal{L}(H_2, X)$. If*

$$\|T_1^*x^*\|_{H_1^*} \leq \|T_2^*x^*\|_{H_2^*}, \quad x^* \in X^*,$$

then $T_2 \in \gamma(H_2, X)$ implies $T_1 \in \gamma(H_1, X)$ and for all $1 \leq p < \infty$ we have

$$\|T_1\|_{\gamma^p(H_1, X)} \leq \|T_2\|_{\gamma^p(H_2, X)}.$$

In fact, there exists a linear contraction $U \in \mathcal{L}(H_1, H_2)$ such that $T_1 = T_2U$, and hence $\mathbb{R}(T_1) \subseteq \mathbb{R}(T_2)$.

The analogous result for $\gamma_\infty(H, X)$ also holds and can be obtained with the same proof.

Proof. Put $\tilde{H}_1 = \overline{\mathbb{R}(T_1^*)}$ and $\tilde{H}_2 = \overline{\mathbb{R}(T_2^*)}$. By the assumption the mapping

$$j : T_2^*x^* \mapsto T_1^*x^* \tag{9.28}$$

is well defined and extends to a linear contraction from \tilde{H}_2 to \tilde{H}_1 . We extend j to a contraction in $\mathcal{L}(H_2^*, H_1^*)$ by setting

$$j \equiv 0 \text{ on the orthogonal complement of } \tilde{H}_2. \tag{9.29}$$

Now let $U = j^* \in \mathcal{L}(H_1, H_2)$ where we identify H_i^{**} with H_i for $i = 1, 2$. Then for all $h \in H_1$ and $x^* \in X^*$ we have $\langle T_2 U h, x^* \rangle = \langle h, j T_2^* x^* \rangle = \langle h, T_1^* x^* \rangle = \langle T_1 h, x^* \rangle$. Hence $T_2 U = T_1$ and the result follows from the right ideal property (Theorem 9.1.10). \square

Theorem 9.4.2 (γ -Dominated convergence). *Let $T_n, T \in \mathcal{L}(H, X)$ satisfy $\lim_{n \rightarrow \infty} T_n^* x^* = T^* x^*$ in H^* for all $x^* \in X^*$. If there exists $U \in \gamma(H, X)$ such that*

$$\|T_n^* x^*\|_{H^*} \leq \|U^* x^*\|_{H^*}$$

for all $n \geq 1$ and $x^ \in X^*$, then $T_n, T \in \gamma(H, X)$ and $\lim_{n \rightarrow \infty} T_n = T$ in $\gamma(H, X)$.*

Using Example 9.1.21 one may check that the convergence assertion is false if $\gamma(H, X)$ is replaced by $\gamma_\infty(H, X)$.

Proof. Clearly, $\|(T_n - T)^* x^*\| \leq \|V^* x^*\|$, where $V = 2U$. By Theorem 9.4.1 we have $T_n, T \in \gamma(H, X)$ and $T_n - T = V U_n$ for suitable contractions $U_n \in \mathcal{L}(H)$ given by the analogues of (9.28) and (9.29) in this situation, i.e., $U_n = j_n^*$, where $j_n : V^* x^* \mapsto (T_n - T)^* x^*$ and j_n annihilates $R(V^*)^\perp$. Therefore

$$\|T_n - T\|_{\gamma(H, X)} = \|V U_n\|_{\gamma(H, X)}.$$

We claim that $\lim_{n \rightarrow \infty} U_n^* h^* = 0$ for all $h^* \in \overline{R(V^*)}$. Indeed, if $h^* = V^* x^*$ this follows from (9.28) and the assumption of the theorem, for

$$\lim_{n \rightarrow \infty} U_n^* V^* x^* = \lim_{n \rightarrow \infty} (T_n^* - T^*) x^* = 0.$$

Since $\sup_{n \geq 1} \|U_n\| \leq 1$ this extends to $\lim_{n \rightarrow \infty} U_n^* h^* = 0$ for all $h^* \in \overline{R(V^*)}$ and the claim follows. Now the result follows from Theorem 9.1.14. \square

Applying the result of Theorem 9.4.2 to functions $\phi_n, \phi : S \rightarrow X$ we obtain the following corollary.

Corollary 9.4.3. *Suppose $\phi_n, \phi : S \rightarrow X$ satisfy $\lim_{n \rightarrow \infty} \langle \phi_n, x^* \rangle = \langle \phi, x^* \rangle$ in $L^2(S)$ for all $x^* \in X^*$. If there exists $\psi \in \gamma(S; X)$ such that*

$$\|\langle \phi_n, x^* \rangle\|_{L^2(S)} \leq \|\langle \psi, x^* \rangle\|_{L^2(S)}$$

for all $n \geq 1$ and $x^ \in X^*$, then $\phi_n \in \gamma(S; X)$ and $\lim_{n \rightarrow \infty} \phi_n = \phi$ in $\gamma(S; X)$.*

Example 9.4.4 (Multiplication by bounded functions). If $\phi \in \gamma(S; X)$ and $f \in L^\infty(S)$, then $f\phi \in \gamma(S; X)$ and

$$\|f\phi\|_{\gamma(S; X)} \leq \|f\|_{L^\infty(S)} \|\phi\|_{\gamma(S; X)}.$$

Moreover, if $(f_n)_{n \geq 1}$ is a bounded sequence in $L^\infty(S)$ satisfying $\lim_{n \rightarrow \infty} f_n = f$ almost everywhere, then

$$\lim_{n \rightarrow \infty} \|f_n \phi - f \phi\|_{\gamma(S; X)} = 0.$$

An interesting special case is provided next.

Example 9.4.5 (Truncation). If $\phi \in \gamma(S; X)$, then

$$\lim_{n \rightarrow \infty} \|\phi - \mathbf{1}_{\{\|\phi\| \leq n\}} \phi\|_{\gamma(S; X)} = 0.$$

We continue with an analogue of Fatou’s lemma:

Proposition 9.4.6 (γ -Fatou lemma). *Let $(T_n)_{n \geq 1}$ be a bounded sequence in $\gamma_\infty(H, X)$. If $T \in \mathcal{L}(H, X)$ is an operator such that*

$$\lim_{n \rightarrow \infty} \langle T_n h, x^* \rangle = \langle T h, x^* \rangle, \quad h \in H, \quad x^* \in X^*,$$

then $T \in \gamma_\infty(H, X)$ and for all $1 \leq p < \infty$ we have

$$\|T\|_{\gamma_\infty^p(H, X)} \leq \liminf_{n \rightarrow \infty} \|T_n\|_{\gamma_\infty^p(H, X)}.$$

Proof. Let $\{h_1, \dots, h_K\}$ be an orthonormal system in H . For a fixed $\omega \in \Omega$,

$$\begin{aligned} \left\| \sum_{k=1}^K \gamma_k(\omega) T h_k \right\| &= \sup_{x^* \in B_{X^*}} \left| \left\langle \sum_{k=1}^K \gamma_k(\omega) T h_k, x^* \right\rangle \right| \\ &= \sup_{x^* \in B_{X^*}} \lim_{n \rightarrow \infty} \left| \left\langle \sum_{k=1}^K \gamma_k(\omega) T_n h_k, x^* \right\rangle \right| \leq \liminf_{n \rightarrow \infty} \left\| \sum_{k=1}^K \gamma_k(\omega) T_n h_k \right\|. \end{aligned}$$

Taking p th powers and applying the usual Fatou’s lemma, we deduce that

$$\mathbb{E} \left\| \sum_{k=1}^K \gamma_k T h_k \right\|^p \leq \liminf_{n \rightarrow \infty} \mathbb{E} \left\| \sum_{k=1}^K \gamma_k T_n h_k \right\|^p \leq \liminf_{n \rightarrow \infty} \|T_n\|_{\gamma^p(H; X)}^p.$$

Taking the supremum over all finite orthonormal systems proves the proposition. \square

If $H = L^2(S)$ we may replace the weak convergence assumption by a pointwise convergence assumption:

Corollary 9.4.7. *Let $\phi_n : S \rightarrow X$ be functions in $\gamma_\infty(S; X)$ with*

$$\sup_n \|\phi_n\|_{\gamma_\infty(S; X)} < \infty,$$

and let $\phi : S \rightarrow X$ be a strongly μ -measurable function such that for all $x^* \in X^*$ we have

$$\lim_{n \rightarrow \infty} \langle \phi_n, x^* \rangle = \langle \phi, x^* \rangle \quad \text{almost everywhere.}$$

Then $\phi \in \gamma_\infty(S; X)$ and for all $1 \leq p < \infty$ we have

$$\|\phi\|_{\gamma_\infty^p(S; X)} \leq \liminf_{n \rightarrow \infty} \|\phi_n\|_{\gamma_\infty^p(S; X)}.$$

Proof. We begin by noting that for all $x^* \in X^*$ we have $\|\langle \phi_n, x^* \rangle\|_{L^2(S)} \leq \|\phi_n\|_{\gamma_\infty(S; X)} \|x^*\|$.

We claim that for all $f \in L^2(S)$ and $x^* \in X^*$ we have

$$\lim_{n \rightarrow \infty} \int_S f \langle \phi_n, x^* \rangle \, d\mu = \int_S f \langle \phi, x^* \rangle \, d\mu.$$

To prove this fix an element $x^* \in X^*$. Using the reflexivity of $L^2(S)$, every subsequence (ϕ_{n_k}) of (ϕ_n) has a further subsequence $(\phi_{n_{k_j}})$ such that $\langle \phi_{n_{k_j}}, x^* \rangle \rightarrow g$ weakly in L^2 for some function $g \in L^2(S)$. By the almost everywhere convergence $\langle \phi_n, x^* \rangle \rightarrow \langle \phi, x^* \rangle$ we see that $g = \langle \phi, x^* \rangle$.

The above being true for every subsequence (ϕ_{n_k}) , the claim has been proved. This means that the assumptions of Proposition 9.4.6 are satisfied and the result follows. \square

9.4.b Fubini-type theorems

In this section we consider ‘Fubini type’ isomorphisms of the form

$$\begin{aligned} L^p(S; \gamma(H, X)) &\simeq \gamma(H, L^p(S; X)), \\ \gamma(G, \gamma(H, X)) &\simeq \gamma(H, \gamma(G, X)), \end{aligned}$$

which will be shown to hold for every Banach space X . The special case of the first isomorphism for $X = \mathbb{K}$ has already been established in Section 9.3.a.

Theorem 9.4.8 (γ -Fubini isomorphism). *Let (S, \mathcal{A}, μ) be a σ -finite measure space, let H be a Hilbert space, and let $1 \leq p < \infty$. The mapping $U : L^p(S; \gamma(H, X)) \rightarrow \mathcal{L}(H, L^p(S; X))$ defined by*

$$(Uf)h := f(\cdot)h, \quad h \in H,$$

defines an isometry of Banach spaces

$$L^p(S; \gamma^p(H, X)) \simeq \gamma^p(H, L^p(S; X)).$$

Proof. Let $f \in L^p(S; \gamma(H, X))$ be a μ -simple function of the form $f = \sum_{m=1}^M \mathbf{1}_{S_m} \otimes U_m$, where $U_m = \sum_{n=1}^N h_n^* \otimes x_{mn}$ with $(h_n^*)_{n=1}^N$ orthonormal in H^* . Since each $f(s)$ is a finite rank operator, by (9.10) and Fubini’s theorem we obtain

$$\begin{aligned} \|Uf\|_{\gamma^p(H, L^p(S; X))} &= \left(\mathbb{E} \left\| \sum_{n=1}^N \gamma_n(Uf)h_n \right\|_{L^p(S; X)}^p \right)^{1/p} \\ &= \left(\int_S \mathbb{E} \left\| \sum_{n=1}^N \gamma_n f h_n \right\|^p \, d\mu \right)^{1/p} \\ &= \left(\int_S \|f\|_{\gamma^p(H, X)}^p \, d\mu \right)^{1/p} = \|f\|_{L^p(S; \gamma^p(H, X))}. \end{aligned}$$

Since μ -simple functions f of the above form are dense, this computation shows that U extends to an isometry from $L^p(S; \gamma^p(H, X))$ onto a closed subspace of $\gamma^p(H, L^p(S; X))$. To show that this operator is surjective it is enough to show that its range is dense. However,

$$U\left(\sum_{m=1}^M \mathbf{1}_{S_m} \otimes \left(\sum_{n=1}^N h_n^* \otimes x_{mn}\right)\right) = \sum_{n=1}^N h_n^* \otimes \left(\sum_{m=1}^M \mathbf{1}_{S_m} \otimes x_{mn}\right),$$

for all $S_n \in \mathcal{A}$ with $\mu(S_n) < \infty$, orthonormal $h_1^*, \dots, h_N^* \in H^*$, and arbitrary $x_{mn} \in X$. The elements appearing on the right hand side are dense in $\gamma^p(H, L^p(S; X))$. \square

Proposition 9.4.9. *Let G and H be Hilbert spaces and X be a Banach space. The mapping $g \otimes (h \otimes x) \mapsto h \otimes (g \otimes x)$ extends to an isometric isomorphism of Banach spaces*

$$\gamma^p(G, \gamma^p(H, X)) \simeq \gamma^p(H, \gamma^p(G, X)).$$

Proof. Let $g_1, \dots, g_M \in G$ and $h_1, \dots, h_N \in H$ be orthonormal systems and $(x_{mn})_{m,n=1}^{M,N} \subseteq X$. Then,

$$\left\| \sum_{m=1}^M g_m \otimes \left(\sum_{n=1}^N h_n \otimes x_{mn}\right) \right\|_{\gamma^p(G, \gamma^p(H, X))}^p = \mathbb{E} \mathbb{E}' \left\| \sum_{m=1}^M \gamma_m \sum_{n=1}^N \gamma'_n x_{mn} \right\|^p.$$

Now we apply Fubini's theorem and rewrite the resulting expression as the norm of $\gamma^p(H, \gamma^p(G, X))$. \square

Let G and H be Hilbert spaces. On $G \otimes H$, we define an inner product by

$$(g_1 \otimes h_1 | g_2 \otimes h_2) := (g_1 | g_2)(h_1 | h_2).$$

We write $G \otimes_2 H$ for the completion of $G \otimes H$ with respect to the norm induced by the above inner product.

Theorem 9.4.10 (γ -Fubini theorem). *Let G and H be infinite dimensional Hilbert spaces. For a Banach space X the following assertions are equivalent:*

- (1) X has Pisier's contraction property;
- (2) the mapping

$$g \otimes (h \otimes x) \mapsto (g \otimes h) \otimes x$$

extends to an isomorphism of Banach spaces

$$\gamma(G, \gamma(H, X)) \simeq \gamma(G \otimes_2 H, X).$$

Proof. For elements in the algebraic tensor products, the equivalence of norms is merely a restatement of the inequalities in Corollary 7.5.19. The general result follows by approximation. \square

As an immediate consequence we have the following result.

Corollary 9.4.11. *Let $(S_1, \mathcal{A}_1, \mu_1)$ and $(S_2, \mathcal{A}_2, \mu_2)$ be σ -finite measure spaces. If X has Pisier's contraction property, then*

$$\gamma(L^2(S_1), \gamma(L^2(S_2), X)) \simeq \gamma(L^2(S_1 \times S_2), X).$$

In certain special situations the use of Pisier's contraction property can be avoided. The next example will be useful in Chapter 10.

Example 9.4.12. Let (S, \mathcal{A}, μ) be a measure space, H a Hilbert space and X a Banach space. For a fixed function $g \in L^2(S)$ of norm one, the mapping $\sum_{n=1}^N h_n \otimes x_n \mapsto \sum_{n=1}^N (g \otimes h_n) \otimes x_n$ extends to an isometry of $\gamma(H, X)$ into $\gamma(L^2(S; H), X)$. This allows us to interpret $g \otimes T$, for every operator $T \in \gamma(H, X)$, as an element of $\gamma(L^2(S; H), X)$, and under this identification we have

$$\|g \otimes T\|_{\gamma(L^2(S; H), X)} = \|g \otimes T\|_{\gamma(S; \gamma(H, X))} = \|g\|_{L^2(S)} \|T\|_{\gamma(H, X)}.$$

The second identity is a trivial consequence of Proposition 9.1.3. To prove the first equality, we apply Proposition 9.1.3 twice:

$$\begin{aligned} \left\| \sum_{n=1}^N (g \otimes h_n) \otimes x_n \right\|_{\gamma(L^2(S; H), X)} &= \left\| \sum_{n=1}^N \gamma_n x_n \right\|_{L^2(\Omega; X)} \|g\|_{L^2(S)} \\ &= \left\| \sum_{n=1}^N h_n \otimes x_n \right\|_{\gamma(L^2(S; H), X)} \|g\|_{L^2(S)}. \end{aligned}$$

9.4.c Partitions, type and cotype

An elementary property of the L^p -norms is the following identity for any measurable partition $(S_j)_{j \geq 1} \subseteq \mathcal{A}$ of the underlying measure space (S, \mathcal{A}, μ) :

$$\|f\|_{L^p(S; X)} = \left(\sum_{j \geq 1} \|f|_{S_j}\|_{L^p(S_j; X)}^p \right)^{1/p}.$$

The following result provides conditions for the analogous inequalities ' \leq ' and ' \geq ' for the γ -norm.

Proposition 9.4.13. *Let (S, \mathcal{A}, μ) be a measure space.*

- (1) *Let X have type $p \in [1, 2]$. Let $(S_j)_{j \geq 1} \subseteq \mathcal{A}$ be a partition of S . Then for all $R \in \gamma(L^2(S), X)$ we have*

$$\|R\|_{\gamma(L^2(S), X)} \leq \kappa_{2,p} \tau_{p,X} \left(\sum_{j \geq 1} \|R|_{S_j}\|_{\gamma(L^2(S), X)}^p \right)^{1/p}.$$

(2) Let X have cotype $q \in [2, \infty]$ and let $(S_j)_{j \geq 1} \subseteq \mathcal{A}$ be disjoint. Then for all $R \in \gamma(L^2(S), X)$ we have

$$\left(\sum_{j \geq 1} \|R|_{S_j}\|_{\gamma(L^2(S), X)}^q \right)^{1/q} \leq \kappa_{q, 2C_{q, X}} \|R\|_{\gamma(L^2(S), X)},$$

with the obvious modification if $q = \infty$.

Proof. (1) We may assume that $\mu(S_j) > 0$ for all j . Fixing R , we may also assume that Σ is countably generated. As a result, $L^2(S)$ is separable and we may choose an orthonormal basis $(h_{jk})_{j, k \geq 1}$ for $L^2(S)$ in such a way that for each j the sequence $(h_{jk})_{k \geq 1}$ is an orthonormal basis for $L^2(S_j)$. Let $(\gamma_{jk})_{j, k \geq 1}$ and $(r'_j)_{j \geq 1}$ be a doubly-indexed Gaussian sequence and a Rademacher sequence on probability spaces (Ω, \mathbb{P}) and (Ω', \mathbb{P}') , respectively. By a standard randomisation argument,

$$\begin{aligned} \|R\|_{\gamma(L^2(S), X)} &= \left(\mathbb{E} \left\| \sum_{j, k \geq 1} \gamma_{jk} R h_{jk} \right\|^2 \right)^{1/2} \\ &= \left(\mathbb{E} \left\| \sum_{j, k \geq 1} \gamma_{jk} R|_{S_j} h_{jk} \right\|^2 \right)^{1/2} \\ &= \left(\mathbb{E}' \left\| \sum_{j \geq 1} r'_j \sum_{k \geq 1} \gamma_{jk} R|_{S_j} h_{jk} \right\|_{L^2(\Omega; X)}^2 \right)^{1/2} \\ &\leq \tau_{p, L^2(\Omega; X)} \left(\sum_{j \geq 1} \left\| \sum_{k \geq 1} \gamma_{jk} R|_{S_j} h_{jk} \right\|_{L^2(\Omega; X)}^p \right)^{1/p} \\ &= \kappa_{2, p} \tau_{p, X} \left(\sum_{j \geq 1} \|R|_{S_j}\|_{\gamma(L^2(S), X)}^p \right)^{1/p}. \end{aligned}$$

(2): This is proved similarly. □

9.5 The γ -multiplier theorem

In this section we will study under what conditions an operator-valued function $M : S \rightarrow \mathcal{L}(X, Y)$ acts as a ‘pointwise’ multiplier from $\gamma(S; X)$ to $\gamma(S; Y)$. We have already seen one such example in Example 9.4.4. The general case is more complicated and in general it is not sufficient that the range of M is uniformly bounded. Below it will be shown that in the most common situations M is bounded as a pointwise multiplier if and only if its range is essentially γ -bounded.

To warm up we consider the discrete case $S = \mathbb{N}$ with the counting measure. We fix $1 \leq p < \infty$. By Theorem 9.1.17 we know that $f \in \gamma(\mathbb{N}; X)$ if and only if the sum $\sum_{n \geq 1} \gamma_n f(n)$ converges in $L^p(\Omega; X)$, in which case

$$\|f\|_{\gamma^p(\mathbb{N};X)} = \left\| \sum_{n \geq 1} \gamma_n f(n) \right\|_{L^p(\Omega;X)}.$$

By considering finitely supported functions f , we see that

$$\|Mf\|_{\gamma^p(\mathbb{N};Y)} \leq C \|f\|_{\gamma^p(\mathbb{N};X)}$$

holds if and only if for all $1 \leq m \leq n$ and all $x_m, \dots, x_n \in X$ we have

$$\left\| \sum_{j=m}^n \gamma_j M(j)x_j \right\|_{L^p(\Omega;Y)} \leq C \left\| \sum_{j=m}^n \gamma_j x_j \right\|_{L^p(\Omega;X)}. \quad (9.30)$$

This is clearly true if the range of M is γ -bounded, with constant C equal to its γ -bound. Conversely, (9.30) is almost the definition of γ -boundedness of the range of M , except that (9.30) does not automatically involve possible repetitions of operators $M(j)$, unless M takes each value infinitely many times. However, if X has finite cotype, then (9.30) implies that the range of M is γ -bounded: Following the lines of the proof that γ -boundedness implies R -boundedness under finite cotype (Theorem 8.1.3), (9.30) implies a similar estimate with Rademacher variables ε_j in place of the Gaussian γ_j under the same assumption. But Proposition 8.1.5 guarantees that the resulting R -boundedness type estimate with distinct operators $M(j)$ already implies the full R -boundedness involving possible repetition. This then implies γ -boundedness, again by (Theorem 8.1.3).

9.5.a Sufficient conditions for pointwise multiplication

We will now extend the preceding considerations to general measure spaces (S, \mathcal{A}, μ) . Unlike in the discrete case this requires quite subtle approximation arguments.

The proof of our first main result relies on the γ -Fatou lemma (Proposition 9.4.6). This explains why a mapping from $\gamma(S; X)$ into $\gamma_\infty(S; Y)$ is obtained (rather than from $\gamma(S; X)$ into $\gamma(S; Y)$).

Theorem 9.5.1 (γ -Multiplier theorem). *Suppose that $M : S \rightarrow \mathcal{L}(X, Y)$ is strongly μ -measurable (in the sense of Definition 8.5.1) and has γ -bounded range $\mathcal{M} := \{M(s) : s \in S\}$. Then for every function $\phi : S \rightarrow X$ in $\gamma(S; X)$, the function $M\phi : S \rightarrow Y$ belongs to $\gamma_\infty(S; Y)$ and*

$$\|M\phi\|_{\gamma_\infty(S;Y)} \leq \gamma^p(\mathcal{M}) \|\phi\|_{\gamma^p(S;X)}. \quad (9.31)$$

Furthermore, the mapping $\widetilde{M} : \phi \mapsto M\phi$ has a unique extension to a bounded operator

$$\widetilde{M} : \gamma^p(L^2(S), X) \rightarrow \gamma_\infty^p(L^2(S), Y)$$

of norm $\|\widetilde{M}\| \leq \gamma^p(\mathcal{M})$.

In various situations the range space $\gamma_\infty(S; Y)$ can be replaced by $\gamma(S; Y)$; see Corollaries 9.5.2 and 9.5.3 below.

For the theorem to be applicable, it suffices to know that M has γ -bounded range on $S \setminus N$ for some μ -null set N , provided one replaces $\gamma(\{M(s) : s \in S\})$ by $\gamma(\{M(s) : s \in S \setminus N\})$. This rather obvious observation will be used in the sequence without further comment.

Proof. Let $\phi : S \rightarrow X$ be a μ -simple function which we keep fixed throughout Steps 1 and 2 below.

By virtue of the strong μ -measurability of the functions Mx_j , where x_1, \dots, x_j span a finite-dimensional subspace on X in which ϕ takes its values, we may assume that the σ -algebra \mathcal{A} is μ -essentially countably generated. This implies that $L^2(S)$ is separable, say with orthonormal basis $(g_m)_{m \geq 1}$.

Step 1 – In this step we consider the special case where M is μ -simple. By passing to a common refinement we may assume that

$$\phi = \sum_{j=1}^k \frac{1}{\sqrt{\mu(A_j)}} \mathbf{1}_{A_j} \otimes x_j, \quad M = \sum_{j=1}^k \mathbf{1}_{A_j} \otimes M_j,$$

with disjoint sets $A_j \in \mathcal{A}$ of finite positive measure; we then have $\mathcal{M} = \{M_1, \dots, M_k\}$. Clearly,

$$M\phi = \sum_{j=1}^k \frac{1}{\sqrt{\mu(A_j)}} \mathbf{1}_{A_j} \otimes M_j x_j.$$

This is a μ -simple function with values in Y which therefore defines an element $M\phi \in \gamma^p(S; Y)$. By Example 9.2.4 we obtain

$$\begin{aligned} \|M\phi\|_{\gamma^p(S; Y)}^p &= \mathbb{E} \left\| \sum_{j=1}^k \gamma_j M_j x_j \right\|^p \\ &\leq (\gamma^p(\mathcal{M}))^p \mathbb{E} \left\| \sum_{j=1}^k \gamma_j x_j \right\|^p = (\gamma^p(\mathcal{M}))^p \|\phi\|_{\gamma^p(S; X)}^p. \end{aligned}$$

Step 2 – Let $(S_j)_{j \geq 1}$ be a collection of disjoint sets in \mathcal{A} of finite positive measure that μ -essentially generates \mathcal{A} . By adjoining finitely many sets if necessary and passing to a refinement we may assume that ϕ is $\mu|_{\mathcal{A}_{k_0}}$ -measurable for some $k_0 \geq 1$, where for $k \geq 1$ we set $\mathcal{A}_k := \sigma(S_1, \dots, S_k)$. For a bounded strongly measurable function $\psi : S \rightarrow X$ let

$$P_k \psi := \sum_{j=1}^k \frac{\mathbf{1}_{S_j}}{\mu(S_j)} \int_{S_j} \psi \, d\mu.$$

Define the functions $M_k : S \rightarrow \mathcal{L}(X, Y)$ by $M_k x = P_k(Mx)$. By the Gaussian version of Example 8.5.3, $\gamma^p(M_k(s) : s \in S) \leq \gamma^p(\mathcal{M})$ and therefore Step 1 implies that

$$\|M_k\phi\|_{\gamma^p(S;Y)} \leq \gamma^p(\mathcal{M})\|\phi\|_{\gamma^p(S;X)}. \quad (9.32)$$

It is easily checked that for all $k \geq k_0$ and $f \in L^2(S)$ we have $\mathbb{I}_{M_k\phi}f = \mathbb{I}_{M\phi}P_k f$. Since $P_k \rightarrow I$ strongly on $L^2(S)$ (the convergence being evident for μ -simple functions built on the sets S_j), for all $f \in L^2(S)$ we obtain

$$\lim_{k \rightarrow \infty} \mathbb{I}_{M_k\phi}f = \mathbb{I}_{M\phi}f$$

in Y . As a consequence of this and (9.32), the γ -Fatou lemma (Proposition 9.4.6) implies that $\mathbb{I}_{M\phi} \in \gamma_\infty(L^2(S), Y)$ and

$$\|M\phi\|_{\gamma_\infty^p(S;Y)} \leq \liminf_{k \rightarrow \infty} \|M_k\phi\|_{\gamma_\infty^p(S;Y)} \leq \gamma^p(\mathcal{M})\|\phi\|_{\gamma^p(S;X)}.$$

Step 3 – In Steps 1 and 2 we have shown that (9.31) holds for all μ -simple functions $\phi : S \rightarrow X$. By the density of the μ -simple functions in $\gamma(S; X)$ it follows that the mapping $\widetilde{M}\mathbb{I}_\phi := \mathbb{I}_{M\phi}$ has a unique extension to an operator from $\gamma^p(S; X)$ into $\gamma_\infty^p(S; Y)$ of norm at most $\gamma^p(\mathcal{M})$.

Step 4 – We prove that for all functions $\phi : S \rightarrow X$ in $\gamma(S; X)$, the pointwise product $M\phi$ is weakly in L^2 . (Clearly it is strongly μ -measurable.)

By Proposition 9.2.8 we can find a sequence of μ -simple functions $\phi_n : S \rightarrow Y$ in $\gamma(S; X)$ such that $\phi_n \rightarrow \phi$ in $\gamma(S; X)$ and almost everywhere on S . Thus also $M\phi_n \rightarrow M\phi$ almost everywhere, and hence in particular $\langle M\phi_n, y^* \rangle \rightarrow \langle M\phi, y^* \rangle$ almost everywhere for each $y^* \in Y^*$. On the other hand, by (9.18), we also find, for fixed $y^* \in Y^*$ and $m, n \geq 1$, that

$$\begin{aligned} \|\langle M\phi_n, y^* \rangle - \langle M\phi_m, y^* \rangle\|_{L^2(S)} &= \|\langle M(\phi_n - \phi_m), y^* \rangle\|_{L^2(S)} \\ &\leq \|M(\phi_n - \phi_m)\|_{\gamma_\infty(S;Y)}\|y^*\| \\ &\leq \gamma(\mathcal{M})\|\phi_n - \phi_m\|_{\gamma(S;X)}\|y^*\|. \end{aligned}$$

Therefore, $(\langle M\phi_n, y^* \rangle)_{n \geq 1}$ is a Cauchy sequence, and hence convergent, in $L^2(S)$. But the $L^2(S)$ -limit must coincide with the pointwise almost everywhere limit, and hence $\langle M\phi, y^* \rangle = \lim_{n \rightarrow \infty} \langle M\phi_n, y^* \rangle$ in $L^2(S)$. In particular, $\langle M\phi, y^* \rangle \in L^2(S)$, and hence $M\phi$ is weakly in $L^2(S)$, as claimed.

Step 5 – Finally we prove that for all functions $\phi : S \rightarrow X$ in $\gamma(S; X)$, we have $\widetilde{M}\mathbb{I}_\phi = \mathbb{I}_{M\phi}$, that is, the abstract extension coincides with pointwise multiplication by M .

By definition of the abstract extension, we have

$$\widetilde{M}\mathbb{I}_\phi = \lim_{n \rightarrow \infty} \widetilde{M}\mathbb{I}_{\phi_n} = \lim_{n \rightarrow \infty} \mathbb{I}_{M\phi_n},$$

where the limit is in $\gamma_\infty(L^2(S), Y)$, and *a fortiori* in $\mathcal{L}(L^2(S), Y)$. Taking adjoints and evaluating against $y^* \in Y^*$, it follows in particular that

$$(\widetilde{M}\mathbb{I}_\phi)^*y^* = \lim_{n \rightarrow \infty} \mathbb{I}_{M\phi_n}^*y^* = \lim_{n \rightarrow \infty} \langle M\phi_n, y^* \rangle = \langle M\phi, y^* \rangle = \mathbb{I}_{M\phi}^*y^*,$$

where the limits are in $L^2(S)$. Valid for every $y^* \in Y^*$, this shows that $(\widetilde{M}\mathbb{I}_\phi)^* = \mathbb{I}_{M\phi}^*$ and hence $\widetilde{M}\mathbb{I}_\phi = \mathbb{I}_{M\phi}$, which concludes the proof. \square

Under additional assumptions, \widetilde{M} takes values in $\gamma(S; Y)$:

Corollary 9.5.2. *In addition to the conditions of Theorem 9.5.1, assume that $D \subseteq X$ is a dense set and \mathcal{C} is an algebra of sets μ -essentially generating \mathcal{A} such that for all $x \in D$ and $C \in \mathcal{C}$ with $\mu(C) < \infty$ we have $\mathbf{1}_C Mx \in \gamma(S; Y)$. Then \widetilde{M} maps $\gamma(S; X)$ into $\gamma(S; Y)$.*

In applications this subtlety is important; on $(\mathbb{R}_+, \frac{dt}{t})$ it permits us to check the condition just for finite intervals (a, b) .

Proof. By assumption \widetilde{M} maps all functions of the form $\mathbf{1}_C \otimes x$, where $C \in \mathcal{C}$ and $x \in D$, into $\gamma(S; Y)$. Note that every $E \in \mathcal{A}$ of finite μ -measure is arbitrarily close in μ -measure to some $C \in \mathcal{C}$, and hence $\mathbf{1}_E$ is arbitrarily close in $L^2(S)$ to some indicator of the type $\mathbf{1}_C$. And clearly every $x \in X$ is arbitrarily close to some $x' \in D$ by definition of density. Since $\|\phi \otimes x\|_{\gamma(S; X)} = \|\phi\|_{L^2(S)} \|x\|$, it follows at once that every indicator $\mathbf{1}_E \otimes x$ is arbitrarily close in $\gamma(S; X)$ to some $\mathbf{1}_C \otimes x'$, where $C \in \mathcal{C}$ and $x' \in D$. By the continuity of \widetilde{M} (established in Theorem 9.5.1), \widetilde{M} maps all $\mathbf{1}_E \otimes x$ into $\gamma(S; Y)$, and hence by linearity it maps all simple functions into $\gamma(S; Y)$. By the density of simple functions in $\gamma(S; X)$ and the continuity of \widetilde{M} again, we conclude that $\widetilde{M} : \gamma(S; X) \rightarrow \gamma(S; Y)$, as claimed. \square

As a consequence of Theorem 9.1.20 we also have the following corollary:

Corollary 9.5.3. *In addition to the conditions of Theorem 9.5.1, assume that Y does not contain a copy of c_0 . Then \widetilde{M} maps $\gamma(S; X)$ into $\gamma(S; Y)$.*

9.5.b Necessity of γ -boundedness

We proceed with a converse to Theorem 9.5.1, which is most conveniently phrased in the setting of a *metric measure space*, i.e., a complete separable metric space (S, d) with a measure μ on the Borel σ -algebra $\mathcal{B}(S)$ that is *locally finite* in the sense that every point $s \in S$ has an open neighbourhood of finite μ -measure.

For μ -almost all $s \in S$ it is possible to find an $R > 0$ such that

$$0 < \mu(B(s, r)) < \infty \text{ for all } 0 < r < R.$$

To see this, define the *topological support* $\text{supp}(\mu)$ to be the smallest closed set with the property that its complement has μ -measure 0. Note that $\text{supp}(\mu)$ equals the intersection of all closed sets whose complements have μ -measure 0: the union of these complements can be covered by countably many sets from this union and therefore has μ -measure 0. Now to prove the claim we note that if $s \in \text{supp}(\mu)$, then $\mu(B(s, r)) > 0$ for all $r > 0$, for otherwise this ball would belong to the complement of $\text{supp}(\mu)$. By choosing $r > 0$ small enough we can also guarantee that $\mu(B(s, r)) < \infty$.

A function $M : S \rightarrow \mathcal{L}(X, Y)$ is said to be *strongly locally integrable* if $Mx : S \rightarrow Y$ is locally integrable for all $x \in X$. Note that if M is locally bounded, then it is strongly locally integrable.

A point $s \in \text{supp}(\mu)$ will be called a *strong Lebesgue point* for such a strongly locally integrable function $M : S \rightarrow \mathcal{L}(X, Y)$ if for all $x \in X$ we have

$$\lim_{r \downarrow 0} \frac{1}{\mu(B(s, r))} \int_{B(s, r)} Mx \, d\mu = M(s)x.$$

Example 9.5.4. Let (S, \mathcal{A}, μ) be a metric measure space and let $M : S \rightarrow \mathcal{L}(X, Y)$ be strongly continuous. Then every $s \in \text{supp}(\mu)$ is a strong Lebesgue point of M .

To see this, fix $s \in \text{supp}(\mu)$ and choose arbitrary $x \in X$ and $\varepsilon > 0$. Let $\delta > 0$ be so small that for all $t \in B(s, \delta)$ we have $\|M(s)x - M(t)x\| < \varepsilon$. Then for all sufficiently small $r \in (0, \delta)$,

$$\begin{aligned} & \left\| M(s)x - \frac{1}{\mu(B(s, r))} \int_{B(s, r)} M(t)x \, d\mu(t) \right\| \\ &= \frac{1}{\mu(B(s, r))} \left\| \int_{B(s, r)} M(s)x - M(t)x \, d\mu(t) \right\| \\ &\leq \frac{1}{\mu(B(s, r))} \int_{B(s, r)} \|M(s)x - M(t)x\| \, d\mu(t) \\ &\leq \frac{1}{\mu(B(s, r))} \int_{B(s, r)} \varepsilon \, d\mu(t) = \varepsilon. \end{aligned}$$

Example 9.5.5. Suppose that X is separable and let S be an open subset of \mathbb{R}^n . Let λ denote the Lebesgue measure on S . If $M : S \rightarrow \mathcal{L}(X, Y)$ is strongly λ -measurable (in the sense of Definition 8.5.1) and essentially locally bounded, then almost every $s \in S$ is a strong Lebesgue point for M .

Let $S_0 \subseteq S$ be a measurable set such $\lambda(S \setminus S_0) = 0$ and M is locally bounded on S_0 . Let $\{x_k : k \geq 1\} \subseteq X$ be a countable dense subset. For fixed $k \geq 1$, by the classical Lebesgue differentiation theorem (see Theorem 2.3.4) we can find a measurable set $S_k \subseteq S$ with $\lambda(S \setminus S_k) = 0$ such that for all $s \in S_k$ we have

$$\lim_{r \downarrow 0} \frac{1}{\lambda(B(s, r))} \int_{B(s, r)} \|Mx_k - M(s)x_k\| \, d\lambda = 0. \quad (9.33)$$

Since M is locally bounded, on the set $\bigcap_{k \geq 0} S_k$ the relation (9.33) holds with x_k replaced by an arbitrary $x \in X$. Since $\lambda(S \setminus \bigcap_{k \geq 0} S_k) = 0$ the result follows from this.

The Lebesgue differentiation theorem holds for more general measure spaces, and the above example can be extended to such situations. We refer to the Notes for a discussion of this point.

Proposition 9.5.6. *Let (S, \mathcal{A}, μ) be a non-atomic metric measure space and let $M : S \rightarrow \mathcal{L}(X, Y)$ be a strongly locally integrable function. If there exists a constant $C \geq 0$ such that for all μ -simple functions $\phi : S \rightarrow X$ the function $M\phi$ belongs to $\gamma_\infty(S; Y)$ and*

$$\|M\phi\|_{\gamma_\infty(S; Y)} \leq C \|\phi\|_{\gamma(S; X)},$$

then

$$\mathcal{M} = \{M(s) : s \text{ is a strong Lebesgue point for } M\}$$

is γ -bounded, with $\gamma^p(\mathcal{M}) \leq C$.

Proof. Pick arbitrary $M_1, \dots, M_N \in \mathcal{M}$, say $M_n = M(s_n)$ for certain strong Lebesgue points $s_1, \dots, s_N \in \text{supp}(\mu)$ and pick $x_1, \dots, x_N \in X$. Let $R > 0$ be such that $0 < \mu(B(s_j, r)) < \infty$ for all $1 \leq j \leq n$ and $0 < r < R$.

For $s_0 \in S$ and $0 < \delta < r < R$ consider the annulus

$$A(s_0, \delta, r) := B(s_0, r) \setminus B(s_0, \delta) = \{s \in S : \delta \leq d(s, s_0) < r\}.$$

Thanks to the non-atomicity assumption we have $\mu(A(s_0, \delta, r)) > 0$ for small enough δ , and for those δ we may define the vector $y(s_0, \delta, r; x) \in Y$ by

$$y(s_0, \delta, r; x) := \frac{1}{\mu(A(s_0, \delta, r))} \int_{A(s_0, \delta, r)} Mx \, d\mu.$$

These annuli will be used to circumvent the problem that some of the points s_n might coincide (cf. Remark 9.5.7 below).

Let $\varepsilon > 0$ be fixed. Let $\rho := \min\{d(s_m, s_n) : 1 \leq m, n \leq N, s_m \neq s_n\} \wedge R$ and $\delta_0 := \rho/2$. Since s_1 is a strong Lebesgue point and $\mu(\{s_1\}) = 0$ by the non-atomicity assumption, we can choose numbers $0 < \delta_1 < r_1 < \delta_0$ such that $\mu(A(s_1, \delta_1, r_1)) > 0$ and

$$\|y(s_1, \delta_1, r_1; x_1) - M(s_1)x_1\| < \frac{\varepsilon}{N}. \tag{9.34}$$

In the same way we can recursively choose numbers $\delta_n > 0$ and $r_n > 0$ such that for all $n = 1, \dots, N$,

- (i) $\delta_n < r_n < \delta_{n-1}$,
- (ii) $\mu(A(s_n, \delta_n, r_n)) > 0$,
- (iii) $\|y(s_n, \delta_n, r_n; x_n) - M(s_n)x_n\| < \varepsilon/N$.

Put $A_n := A(s_n, \delta_n, r_n)$ and $y_n := y(s_n, \delta_n, r_n; x_n)$. The definition of ρ and the fact that we have imposed $r_n < \rho/2$ guarantee that the sets A_n , $n = 1, \dots, N$, are disjoint. Define

$$\phi := \sum_{n=1}^N \frac{1}{\sqrt{\mu(A_n)}} \mathbf{1}_{A_n} \otimes x_n, \quad \psi := \sum_{n=1}^N \frac{1}{\sqrt{\mu(A_n)}} \mathbf{1}_{A_n} \otimes M(s_n)x_n.$$

For functions $\zeta : S \rightarrow X$ belonging to $\gamma_\infty(S; X)$ we define the μ -simple function $P\zeta : S \rightarrow X$ by

$$P\zeta := \sum_{n=1}^N \frac{1}{\mu(A_n)} \mathbf{1}_{A_n} \otimes \int_{A_n} \zeta \, d\mu.$$

For $f \in L^2(S)$ we have $\mathbb{I}_{P\zeta} f = \mathbb{I}_\zeta P f$, where on the right-hand side we consider P as a projection in $L^2(S)$, and therefore, by the right ideal property,

$$\|P\zeta\|_{\gamma_\infty(S; Y)} = \|\mathbb{I}_\zeta \circ P\|_{\gamma_\infty(S; Y)} \leq \|\mathbb{I}_\zeta\|_{\gamma_\infty(S; Y)} = \|\zeta\|_{\gamma_\infty(S; Y)}. \tag{9.35}$$

It is easily checked that

$$PM\phi = \sum_{n=1}^N \frac{1}{\sqrt{\mu(A_n)}} \mathbf{1}_{A_n} \otimes y_n$$

and therefore, by (9.34),

$$\|\psi - PM\phi\|_{\gamma_\infty(S; Y)} = \left\| \sum_{n=1}^N \gamma_n(M(s_n)x_n - y_n) \right\|_{L^2(\Omega; Y)} < \varepsilon.$$

By the disjointness of the sets A_n (in (a) and (c) below) and (9.35) (in (b)),

$$\begin{aligned} \left\| \sum_{n=1}^N \gamma_n M(s_n)x_n \right\|_{L^2(\Omega; Y)} &\stackrel{(a)}{=} \|\psi\|_{\gamma_\infty(S; Y)} \leq \varepsilon + \|PM\phi\|_{\gamma_\infty(S; Y)} \\ &\stackrel{(b)}{\leq} \varepsilon + \|M\phi\|_{\gamma_\infty(S; Y)} \leq \varepsilon + C\|\phi\|_{\gamma(S; X)} \\ &\stackrel{(c)}{=} \varepsilon + C\left(\mathbb{E}\left\| \sum_{n=1}^N \gamma_n x_n \right\|^2\right)^{1/2}. \end{aligned}$$

Since $\varepsilon > 0$ was arbitrary, this completes the proof. □

Remark 9.5.7 (The role of annuli). If, in the above proof, we used balls rather than the annuli A_n , a problem with repeating entries will occur if $s_m = s_n$ for certain $m \neq n$. The proof makes essential use of the fact that the functions $\mathbf{1}_{A_n}/\sqrt{\mu(A_n)}$ are orthonormal in $L^2(S)$; the corresponding assertion for the indicators of balls would fail in this case.

Remark 9.5.8 (The case when X has finite cotype). If X has finite cotype, then a subset of $\mathcal{L}(X, Y)$ is γ -bounded if and only if it is R -bounded (Theorem 8.6.4). In order to test R -boundedness of \mathcal{M} , by Proposition 8.1.5 it suffices to check the R -boundedness inequality for pairwise distinct operators. In the proof of the proposition it then suffices to consider distinct points s_n . In this situation there is no need to use annuli, and if one works with balls there is no need to exclude atoms. Hence, the non-atomicity assumption is redundant

if X has finite cotype (at the expense of extra constants in the estimate due to changing back and forth to Rademacher sums).

It is an open problem whether the analogue of Proposition 8.1.5 for γ -boundedness holds.

As an application of the γ -multiplier theorem we show next that as soon as we have a square function estimate for (say) the Lebesgue measure, it holds for every Borel measure. We formulate the result for strongly continuous functions M ; the reader may check that an analogous result holds if $Mx \in L^\infty(S; Y)$ for all $x \in X$ (strong boundedness is needed to pass from (3) to (2); it guarantees that M is locally integrable with respect to every locally finite measure μ).

Corollary 9.5.9. *Let (S, \mathcal{A}, μ) be a metric measure space and let (T, \mathcal{B}, ν) be a measure space. Fix $1 \leq p < \infty$ and let $M : S \rightarrow \mathcal{L}(L^p(T))$ be strongly continuous. The following assertions are equivalent:*

- (1) *there exists a constant $C \geq 0$ such that for all $\phi \in L^p(T; L^2(S, \mu))$ we have $M\phi \in L^p(T; L^2(S, \mu))$ and*

$$\|M\phi\|_{L^p(T; L^2(S, \mu))} \leq C \|\phi\|_{L^p(T; L^2(S, \mu))};$$

- (2) *there exists a constant $C \geq 0$ such that for all locally finite Borel measures λ on S satisfying $\text{supp}(\lambda) \subseteq \text{supp}(\mu)$ and all $\phi \in L^p(T; L^2(S, \lambda))$ we have $M\phi \in L^p(T; L^2(S, \lambda))$ and*

$$\|M\phi\|_{L^p(T; L^2(S, \lambda))} \leq C \|\phi\|_{L^p(T; L^2(S, \lambda))};$$

- (3) $\mathcal{M} = \{M(s) : s \in \text{supp}(\mu)\}$ *is γ -bounded.*

Proof. Recall from (9.22) that

$$\|\phi\|_{\gamma(T, L^p(S))} = \|\gamma\|_{L^p(\Omega)} \|\phi\|_{L^p(S; L^2(T))}. \quad (9.36)$$

(1) \Rightarrow (3): Let $\phi : S \rightarrow L^p(T)$ be μ -simple. It follows from the assumption in (1) and (9.36) that

$$\|M\phi\|_{\gamma^p(S, \mu; L^p(T))} \leq C \|\phi\|_{\gamma^p(S, \mu; L^p(T))}.$$

Hence Proposition 9.5.6 implies that $\gamma_p(\mathcal{M}) \leq C$.

(3) \Rightarrow (2): Since $L^p(T)$ does not contain a copy of c_0 , by Theorem 9.1.20 we have $\gamma_\infty^p(S, \lambda; L^p(T)) = \gamma^p(S, \lambda; L^p(T))$. Hence by Theorem 9.5.1 applied to $(S, \mathcal{B}(S), \lambda)$ (and the observation following its statement) and (9.36),

$$\begin{aligned} \|M\phi\|_{\gamma^p(S, \lambda; L^p(T))} &\leq \gamma^p(\mathcal{M}) \|\phi\|_{\gamma^p(S, \lambda; L^p(T))} \\ &\leq \gamma^p(\mathcal{M}) \|\gamma\|_{L^p(\Omega)} \|\phi\|_{L^p(T; L^2(S, \lambda))}. \end{aligned}$$

Now the result follows from (9.36).

- (2) \Rightarrow (1): This is trivial. \square

In applications one often takes (S, \mathcal{A}, μ) to be an open domain in \mathbb{R}^d with the Lebesgue measure, in which case the inclusion of the supports in (2) is automatic.

9.6 Extension theorems

In Chapter 2 we have seen various examples of bounded operators T on spaces $L^2(S)$ whose tensor extension $T \otimes I_X$ fails to extend boundedly to $L^2(S; X)$. These include some of the principal operators in Analysis, such as the Fourier–Plancherel transform, the Hilbert transform, and the Itô isometry. In general, whether or not a given operator has a bounded vector-valued counterpart is closely linked with the geometry of the Banach space X . In this section we will show that the tensor extension of any bounded operator on $L^2(S)$ extends boundedly to $\gamma(S; X)$, for any Banach space X . This is a first demonstration of the general principle that $\gamma(S; X)$ is a natural vector-valued analogue of $L^2(S)$ as far as vector-valued Analysis is concerned, much in the same way as randomised boundedness takes over the role of uniform boundedness.

9.6.a General extension results

In this subsection we deal with the general theory that is valid without further assumptions on the Banach space X .

As an application of the ideal property we first show that the tensor extension of a bounded operator $U : H_1 \rightarrow H_2$ acts boundedly as an operator from $\gamma(H_1^*, X)$ to $\gamma(H_2^*, X)$.

As always, we do not identify Hilbert spaces with their duals and denote by U^* the Banach space adjoint of U .

Theorem 9.6.1. *Let H_1 and H_2 be Hilbert spaces. For all bounded linear operators $U : H_1 \rightarrow H_2$ the mapping*

$$U \otimes I_X : h \otimes x \mapsto Uh \otimes x, \quad h \in H_1, x \in X,$$

has a unique extension to a bounded linear operator $\tilde{U} : \gamma(H_1^, X) \rightarrow \gamma(H_2^*, X)$ of the same norm. For all $T \in \gamma(H_1^*, X)$ we have the identity*

$$\tilde{U}T = T \circ U^*.$$

Proof. For any rank one operator $T = h \otimes x$, where $h \in H_1$ and $x \in X$, and any $g^* \in H_2^*$, we have

$$\tilde{U}Tg^* = (Uh \otimes x)g^* = \langle Uh, g^* \rangle x = \langle h, U^*g^* \rangle x = (h \otimes x)U^*g^* = TU^*g^*.$$

By linearity we obtain the identity $\tilde{U}T = T \circ U^*$ for all finite rank operators $T : H_1^* \rightarrow X$. By the right-ideal property it follows that $\|\tilde{U}T\|_{\gamma(H_2^*, X)} \leq \|U\| \|T\|_{\gamma(H_1^*, X)}$. By density \tilde{U} has a unique extension to a bounded linear operator \tilde{U} from $\gamma(H_1^*, X)$ into $\gamma(H_2^*, X)$ of norm $\|\tilde{U}\| \leq \|U\|$. The reverse estimate $\|U\| \leq \|\tilde{U}\|$ is trivial. \square

At first sight it may seem natural to extend U to an operator $\tilde{U}' : \gamma(H_1, X) \rightarrow \gamma(H_2, X)$ by defining it as the mapping $T \mapsto T \circ U^*$, where U^* is the Hilbert space adjoint of U , but this definition does not agree with the tensor extension of U when the scalar field is complex. The simplest way to see this is to observe that over the complex scalars the mapping $U \mapsto \tilde{U}'$ is conjugate-linear instead of linear; on the other hand, the mapping $U \mapsto U \otimes I_X$ is obviously linear.

Remark 9.6.2. The identity $\tilde{U}T = T \circ U^*$ even extends $U \otimes I_X$ to a bounded operator from $\gamma_\infty(H_1^*, X)$ into $\gamma_\infty(H_2^*, X)$. In general however, this extension is non-unique (apart from the case $c_0 \not\subseteq X$, in which case $\gamma_\infty(H^*, X) = \gamma(H^*, X)$ for any Hilbert space H).

Example 9.6.3 (The case $H = L^2(S)$). Next we consider the important special case $H_j = L^2(S_j)$, where $(S_j, \mathcal{A}_j, \mu_j)$ are measure spaces ($j = 1, 2$). Let $U : L^2(S_1) \rightarrow L^2(S_2)$ be bounded. Suppose that a function $\phi : S_1 \rightarrow X$ of the form

$$\phi = f \otimes x$$

is given, with $f \in L^2(S_1)$ and $x \in X$, and let $\mathbb{I}_\phi : L^2(S) \rightarrow X$ be the associated integral operator,

$$\mathbb{I}_\phi g = \int_S g \phi \, d\mu = \langle f, g \rangle x,$$

identifying in the last identity the function $g \in L^2(S)$ with the functional in the Banach space dual $(L^2(S))^*$ given by the action $h \mapsto \int_S gh \, d\mu$. Then we see that

$$(\tilde{U}\mathbb{I}_\phi)g = \mathbb{I}_\phi \circ U^*g = \langle f, U^*g \rangle x = \langle Uf, g \rangle x = \mathbb{I}_{(U \otimes I_X)\phi}g.$$

Example 9.6.4 (Kernel operators). Let $k : S_1 \times S_2 \rightarrow \mathbb{K}$ be a $\mu_1 \times \mu_2$ -measurable function which is integrable on sets of finite measure. Suppose that the operator U_k , defined on μ_1 -simple functions $f : S_1 \rightarrow \mathbb{K}$ by

$$U_k f(t) = \int_{S_1} k(s, t) f(s) \, d\mu_1(s),$$

extends to a bounded operator from $L^2(S_1)$ into $L^2(S_2)$. Then Theorem 9.6.1 provides us with a bounded extension $\tilde{U}_k : \gamma(L^2(S_1), X) \rightarrow \gamma(L^2(S_2), X)$ which for μ_1 -simple functions $\phi : S_1 \rightarrow X$ takes the form

$$(\tilde{U}_k \mathbb{I}_\phi)(t) = \int_{S_1} k(s, t) \phi(s) \, d\mu_1(s).$$

Note that the Banach space adjoint operator is given by

$$(U_k^* g)(s) = \int_{S_2} k(s, t) g(t) \, d\mu_2(t);$$

in particular $U_k^* = U_k$ if and only if $k(s, t) = k(t, s)$ (no conjugation; this is because we consider the Banach space adjoint).

Example 9.6.5 (Fourier–Plancherel transform). In this example the scalar field is \mathbb{C} . We apply the above observations to the Fourier–Plancherel isometry \mathcal{F} on $L^2(\mathbb{R}^d)$,

$$\mathcal{F}f(\xi) = \int_{\mathbb{R}^d} \exp(-2\pi i x \cdot \xi) f(x) dx, \quad \xi \in \mathbb{R}^d.$$

As we have seen in Section 2.1, this operator extends to a bounded operator on $L^2(\mathbb{R}^d; X)$ only if X is isomorphic to a Hilbert space. In contrast, Theorem 9.6.1 shows that \mathcal{F} has an isometric extension $\widetilde{\mathcal{F}}$ to $\gamma(L^2(\mathbb{R}^d), X)$ given by $\widetilde{\mathcal{F}}T = T \circ \mathcal{F}^* = T \circ \mathcal{F}$, where we used that $\mathcal{F}^* = \mathcal{F}$ (cf. the previous example); once again we remind the reader that \mathcal{F}^* is the Banach space adjoint. By Example 9.6.4, for all simple functions $\phi : \mathbb{R}^d \rightarrow X$ we have

$$\widetilde{\mathcal{F}}\phi(\xi) = \int_{\mathbb{R}^d} \exp(-2\pi i x \cdot \xi) \phi(x) dx, \quad \xi \in \mathbb{R}^d.$$

Example 9.6.6 (Young’s inequality). For a fixed $k \in L^1(\mathbb{R}^d)$, the convolution operator $C_k : f \mapsto f * k$ is bounded on $L^2(\mathbb{R}^d)$ and satisfies $\|C_k\| \leq \|k\|_{L^1(\mathbb{R}^d)}$. Therefore, it extends to a bounded operator \widetilde{C}_k on $\gamma(L^2(\mathbb{R}^d), X)$ of the same norm. For all simple functions $\phi : \mathbb{R}^d \rightarrow \mathbb{K}$ we have

$$C_k\phi(x) = \int_{\mathbb{R}^d} k(y-x)\phi(x) dx, \quad x \in \mathbb{R}^d.$$

We continue with two abstract examples which will play an important role in the next subsection.

Example 9.6.7 (Tensors). When we view an element $h \in H$ as a bounded operator T_h from \mathbb{K} to H , given by $T_h c = ch$, and identify $\gamma(\mathbb{K}, X)$ with X in the natural way, then $\widetilde{T}_h \in \mathcal{L}(X, \gamma(H^*, X))$ is given by

$$\widetilde{T}_h x = h \otimes x.$$

Example 9.6.8 (Evaluations). When we view an element $h \in H$ as a bounded operator E_h from H^* to \mathbb{K} , given by $E_h h^* = \langle h, h^* \rangle$, and identify $\gamma(\mathbb{K}, X)$ with X in the natural way, then $\widetilde{E}_h \in \mathcal{L}(\gamma(H, X), X)$ is given by

$$\widetilde{E}_h T = Th.$$

The final result of this subsection has a different flavour in that it deals with the extension of operators initially defined on the Banach space target X , rather than the Hilbert space domain H , of $\gamma(H, X)$.

Proposition 9.6.9. *Let \mathcal{T} be a bounded subset of $\mathcal{L}(X, Y)$ and let H be a Hilbert space. For each $T \in \mathcal{T}$ let $\widetilde{T} \in \mathcal{L}(\gamma(H, X), \gamma(H, Y))$ be defined by $\widetilde{T}R := T \circ R$. The collection $\widetilde{\mathcal{T}} = \{\widetilde{T} : T \in \mathcal{T}\}$ is bounded, with*

$$\sup_{T \in \mathcal{T}} \|T\| = \sup_{\tilde{T} \in \tilde{\mathcal{T}}} \|\tilde{T}\|.$$

If \mathcal{T} is γ -bounded, then so is $\tilde{\mathcal{T}}$ and we have

$$\gamma(\tilde{\mathcal{T}}) = \gamma(\mathcal{T}).$$

Proof. The boundedness assertion is clear, and we concentrate on the γ -boundedness. Let $(\gamma_j)_{j \geq 1}$ and $(\tilde{\gamma}_j)_{j \geq 1}$ be two sequences of independent standard Gaussian random variables, on probability spaces (Ω, \mathbb{P}) and $(\tilde{\Omega}, \tilde{\mathcal{F}}, \tilde{\mathbb{P}})$ respectively. Let $(h_i)_{i=1}^n$ be a finite orthonormal system in H . Then

$$\begin{aligned} \mathbb{E} \tilde{\mathbb{E}} \left\| \sum_{i=1}^n \tilde{\gamma}_i \sum_{j=1}^k \gamma_j T_j R_j h_i \right\|^2 &= \tilde{\mathbb{E}} \mathbb{E} \left\| \sum_{j=1}^k \gamma_j T_j \sum_{i=1}^n \tilde{\gamma}_i R_j h_i \right\|^2 \\ &\leq \gamma^2(\mathcal{T}) \tilde{\mathbb{E}} \mathbb{E} \left\| \sum_{j=1}^k \gamma_j \sum_{i=1}^n \tilde{\gamma}_i R_j h_i \right\|^2 \\ &= \gamma^2(\mathcal{T}) \mathbb{E} \tilde{\mathbb{E}} \left\| \sum_{i=1}^n \tilde{\gamma}_i \sum_{j=1}^k \gamma_j R_j h_i \right\|^2 \\ &\leq \gamma^2(\mathcal{T}) \mathbb{E} \left\| \sum_{j=1}^k \gamma_j R_j \right\|_{\gamma(H, X)}^2. \end{aligned}$$

Taking the supremum over all finite orthonormal systems, we arrive at

$$\mathbb{E} \left\| \sum_{j=1}^k \gamma_j \tilde{T}_j R_j \right\|_{\gamma(H, Y)}^2 \leq \gamma^2(\mathcal{T}) \mathbb{E} \left\| \sum_{j=1}^k \gamma_j R_j \right\|_{\gamma(H, X)}^2.$$

This proves the inequality $\gamma(\tilde{\mathcal{T}}) \leq \gamma(\mathcal{T})$. The reverse inequality holds trivially. \square

9.6.b R -bounded extensions via Pisier’s contraction property

In this and the following subsection we pursue the topic of extending Hilbert space operators to spaces of γ -radonifying operators in the presence of additional Banach space properties (in contrast to the results of Section 9.6.a that are valid for general spaces).

If \mathcal{S} is a uniformly bounded family of operators in $\mathcal{L}(H_1, H_2)$, the family $\tilde{\mathcal{S}} = \{\tilde{S} : S \in \mathcal{S}\}$ as defined in Theorem 9.6.1 is uniformly bounded in $\mathcal{L}(\gamma(H_1^*, X), \gamma(H_2^*, X))$. In the situation that X has Pisier’s contraction property (see Definition 7.5.1) we can say more: in that case $\tilde{\mathcal{S}}$ is γ -bounded in $\mathcal{L}(\gamma(H_1^*, X), \gamma(H_2^*, X))$.

Recall from (7.46) that X has Pisier’s contraction property if and only if there exist constants α_+ and α_- such that

$$\begin{aligned}\mathbb{E}\left\|\sum_{m=1}^M\sum_{n=1}^N\gamma_{mn}x_{mn}\right\|^2 &\leq\alpha_+^2\mathbb{E}'\mathbb{E}''\left\|\sum_{m=1}^M\sum_{n=1}^N\gamma'_m\gamma''_n x_{mn}\right\|^2, \\ \mathbb{E}'\mathbb{E}''\left\|\sum_{m=1}^M\sum_{n=1}^N\gamma'_m\gamma''_n x_{mn}\right\|^2 &\leq\alpha_-^2\mathbb{E}\left\|\sum_{m=1}^M\sum_{n=1}^N\gamma_{mn}x_{mn}\right\|^2.\end{aligned}$$

The least constants in these inequalities will be denoted by $\alpha_+^\gamma(X)$ and $\alpha_-^\gamma(X)$.

Theorem 9.6.10 (Haak–Kunstmann). *Let $\mathcal{S} \subseteq \mathcal{L}(H_1, H_2)$ be a uniformly bounded family of operators. If X has Pisier's contraction property, then its extension $\widetilde{\mathcal{S}}$ is γ -bounded and R -bounded in $\mathcal{L}(\gamma(H_1^*, X), \gamma(H_2^*, X))$ and*

$$\gamma(\widetilde{\mathcal{S}}) \leq \alpha_+^\gamma(X)\alpha_-^\gamma(X) \sup_{S \in \mathcal{S}} \|S\|.$$

Proof. Let $\alpha_+ = \alpha_+^\gamma(X)$ and $\alpha_- = \alpha_-^\gamma(X)$. Assuming without loss of generality that $\sup_{S \in \mathcal{S}} \|S\| \leq 1$, we must prove that for all $S_1, \dots, S_N \in \mathcal{L}(H_1, H_2)$ of norm at most one and all $T_1, \dots, T_N \in \gamma(H_1^*, X)$,

$$\mathbb{E}\left\|\sum_{n=1}^N\gamma_n\widetilde{S}_nT_n\right\|_{\gamma(H_2^*, X)}^2 \leq \alpha_+^2\alpha_-^2\mathbb{E}\left\|\sum_{n=1}^N\gamma_nT_n\right\|_{\gamma(H_1^*, X)}^2.$$

For this purpose it suffices to assume that each of the T_n has finite rank, and by an orthogonalisation procedure we may even assume that

$$T_n = \sum_{m=1}^M h_m \otimes x_{mn},$$

where $(h_m)_{m=1}^M$ is some fixed orthonormal system in H_1 .

Choose an orthonormal basis $(g_k)_{k=1}^K$ for the span of $\{S_n h_m : 1 \leq m \leq M, 1 \leq n \leq N\}$ in H_2 and denote the corresponding functionals in H_2^* by $(g_k^*)_{k=1}^K$, i.e., $\langle h, g_k^* \rangle := (h|g_k)$. Applying Proposition 9.1.3,

$$\begin{aligned}\mathbb{E}\left\|\sum_{n=1}^N\gamma_n\widetilde{S}_nT_n\right\|_{\gamma(H_2^*, X)}^2 &= \mathbb{E}\left\|\sum_{n=1}^N\gamma_n\sum_{m=1}^M S_n(h_m \otimes x_{mn})\right\|_{\gamma(H_2^*, X)}^2 \\ &= \mathbb{E}\mathbb{E}'\left\|\sum_{k=1}^K\gamma'_k\sum_{n=1}^N\sum_{m=1}^M\gamma_n\langle S_n h_m, g_k^* \rangle x_{mn}\right\|^2 \\ &= \mathbb{E}\mathbb{E}'\left\|\sum_{k=1}^K\sum_{l=1}^N\gamma'_k\gamma_l\sum_{n=1}^N\sum_{m=1}^M\delta_{ln}\langle S_n h_m, g_k^* \rangle x_{mn}\right\|^2 \\ &\leq \alpha_-^2\mathbb{E}\left\|\sum_{k=1}^K\sum_{l=1}^N\gamma_{kl}\sum_{n=1}^N\sum_{m=1}^M\delta_{ln}\langle S_n h_m, g_k^* \rangle x_{mn}\right\|^2 \\ &\stackrel{(*)}{\leq} \alpha_-^2\mathbb{E}\left\|\sum_{n=1}^N\sum_{m=1}^M\gamma_{mn}x_{mn}\right\|^2\end{aligned}$$

$$\begin{aligned} &\leq \alpha_-^2 \alpha_+^2 \mathbb{E} \mathbb{E}' \left\| \sum_{m=1}^M \gamma'_m \sum_{n=1}^N \gamma_n x_{mn} \right\|^2 \\ &= \alpha_-^2 \alpha_+^2 \mathbb{E} \left\| \sum_{m=1}^M h_m \otimes \sum_{n=1}^N \gamma_n x_{mn} \right\|_{\gamma(H_1^*, X)}^2 \\ &= \alpha_-^2 \alpha_+^2 \mathbb{E} \left\| \sum_{n=1}^N \gamma_n T_n \right\|_{\gamma(H_1^*, X)}^2, \end{aligned}$$

where (*) follows from Proposition 6.1.23 by considering the matrix $A : \ell_{MN}^2 \rightarrow \ell_{KN}^2$ with coefficients $a_{(kl),(mn)} = \delta_{ln} \langle S_n h_m, g_k^* \rangle$. To estimate the operator norm of A we note that if $\sum_{m,n} |c_{mn}|^2 \leq 1$, then by the assumption $\sup_{1 \leq n \leq N} \|S_n\| \leq 1$ and the orthonormality of $(g_k^*)_{k \geq 1}$ and $(h_m)_{m \geq 1}$,

$$\begin{aligned} \|Ac\|^2 &= \sum_{l=1}^N \sum_{k=1}^K \left| \sum_{n=1}^N \sum_{m=1}^M \delta_{ln} \langle S_n h_m, g_k^* \rangle c_{mn} \right|^2 \\ &= \sum_{l=1}^N \sum_{k=1}^K \left| \left\langle S_l \sum_{m=1}^M c_{ml} h_m, g_k^* \right\rangle \right|^2 \\ &\leq \sum_{l=1}^N \left\| S_l \sum_{m=1}^M c_{ml} h_m \right\|^2 \leq \sum_{l=1}^N \left\| \sum_{m=1}^M c_{ml} h_m \right\|^2 = \sum_{l=1}^N \sum_{m=1}^M |c_{ml}|^2 \leq 1. \end{aligned}$$

This proves the first part of the result.

Pisier’s contraction property implies finite cotype by Corollary 7.5.13. Thus the R -boundedness of \mathcal{S} follows from its γ -boundedness by Theorem 8.1.3, which also contains additional quantitative information. \square

We have the following converse to Theorem 9.6.10:

Proposition 9.6.11. *Let H_1 and H_2 be infinite-dimensional Hilbert spaces and let X be a Banach space. If the family*

$$\mathcal{U} = \{ \tilde{U} : U \in \mathcal{L}(H_1, H_2), \|U\| \leq 1 \}$$

is γ -bounded in $\mathcal{L}(\gamma(H_1^, X), \gamma(H_2^*, X))$, then X has Pisier’s contraction property and $\alpha_X^\gamma \leq \gamma(\mathcal{U})$.*

Proof. Fix a sequence $(x_{mn})_{m,n=1}^{M,N}$ in X and let $(a_{mn})_{m,n=1}^{M,N}$ be a scalar sequence with $|a_{mn}| \leq 1$ for all m, n . Let $(h_m)_{m=1}^M$ be an orthonormal system in H_1 and let $(g_n)_{n=1}^N$ be an orthonormal system in H_2 . For $m = 1, \dots, M$ and $n = 1, \dots, N$ let $S_n : H_1 \rightarrow H_2$ and $T_n : H_1 \rightarrow X$ be defined by

$$S_n h_m := a_{mn} g_m \quad \text{and} \quad T_n h_m := x_{mn}.$$

We extend these definitions by setting $S_n \equiv 0$ and $T_n \equiv 0$ on the orthogonal complement of the linear span of $\{h_1, \dots, h_N\}$. Then $\|S_n\| \leq 1$, $S_n^* g_m = a_{mn} h_m$ and by Proposition 9.1.3 we have

$$\begin{aligned}
 \mathbb{E} \left\| \sum_{n=1}^N \sum_{m=1}^M \gamma_n \gamma'_m a_{mn} x_{mn} \right\|^2 &= \mathbb{E} \left\| \sum_{n=1}^N \gamma_n \sum_{m=1}^M \gamma'_m T_n S_n^* g_m \right\|^2 \\
 &= \mathbb{E} \left\| \sum_{n=1}^N \gamma_n \tilde{S}_n T_n \right\|_{\gamma(H_2^*, X)}^2 \\
 &\leq \gamma(\mathcal{U})^2 \mathbb{E} \left\| \sum_{n=1}^N \gamma_n T_n \right\|_{\gamma(H_1^*, X)}^2 \\
 &= \gamma(\mathcal{U})^2 \mathbb{E} \left\| \sum_{n=1}^N \sum_{m=1}^M \gamma_n \gamma'_m x_{mn} \right\|^2.
 \end{aligned}$$

□

Inspecting the proof of Theorem 9.6.10 we see that the estimate for the γ -bound simplifies when one of the Hilbert spaces is the scalar field:

- If $H_1 = \mathbb{K}$, then $\gamma(\tilde{\mathcal{S}}) \leq \alpha_-^\gamma(X)$;
- If $H_2 = \mathbb{K}$, then $\gamma(\tilde{\mathcal{S}}) \leq \alpha_+^\gamma(X)$.

Combining Examples 9.6.7 and 9.6.8 with the above, we obtain the following corollary.

Corollary 9.6.12. *Let X be a Banach space with Pisier’s contraction property and let H be a Hilbert space.*

- (1) *For each $h \in H$ define the operator $T_h : X \rightarrow \gamma(H^*, X)$ by*

$$T_h x := h \otimes x.$$

Then the family $\mathcal{T} = \{T_h : \|h\| \leq 1\}$ is γ -bounded and $\gamma(\mathcal{T}) \leq \alpha_-^\gamma(X)$.

- (2) *For each $h \in H$ define the operator $E_h : \gamma(H, X) \rightarrow X$ by*

$$E_h T := T h.$$

Then the family $\mathcal{E} = \{E_h : \|h\| \leq 1\}$ is γ -bounded and $\gamma(\mathcal{E}) \leq \alpha_+^\gamma(X)$.

Since every Banach space with Pisier’s contraction property has finite cotype (Corollary 7.5.13), one can replace γ -boundedness by R -boundedness at the expense of an additional multiplicative constant.

9.6.c R -bounded extensions via type and cotype

In this section we will study the estimates of Corollary 9.6.12 using type and cotype of X instead of Pisier’s contraction property.

Theorem 9.6.13. *Let X be a Banach space and let H be an infinite dimensional Hilbert space. For each $h \in H$ define the operator $T_h : X \rightarrow \gamma(H^*, X)$ by*

$$T_h x := h \otimes x.$$

The following are equivalent:

- (1) *the family $\mathcal{F} = \{T_h : \|h\| \leq 1\}$ is R -bounded;*
- (2) *the family $\mathcal{F} = \{T_h : \|h\| \leq 1\}$ is γ -bounded;*
- (3) *the space X has finite cotype.*

Furthermore in this case

$$\mathcal{R}(\mathcal{F}) \leq 3\|\gamma\|_{2q\kappa_{q,2}c_{q,X}},$$

whenever X has cotype q .

Since Pisier's contraction property implies finite cotype, this result is an improvement of Corollary 9.6.12(1). In the quantitative bound above, $\kappa_{q,2}$ is the constant from the Kahane–Khintchine inequality.

Proof. (3) \Rightarrow (1): Fix f_1, \dots, f_N in the unit ball of H and x_1, \dots, x_N in X . Let $(h_k)_{k=1}^K$ be an orthonormal basis for the span of $\{f_1, \dots, f_N\}$ and let $h_k^* := \psi_{h_k}$ as in (9.5). Let X have cotype $q \in [2, \infty)$ and fix $r \in (q, \infty)$. For $\xi_n = \sum_{k=1}^K \gamma'_k \langle f_n, h_k^* \rangle$, from (9.13) we see that $\xi_n \in L^r(\Omega')$ and

$$\|\xi_n\|_r = \|\gamma\|_r \left(\sum_{k=1}^K |\langle f_n, h_k^* \rangle|^2 \right)^{1/2} = \|\gamma\|_r \|f_n\|_H \leq \|\gamma\|_r.$$

Therefore, by Proposition 9.1.3 and Theorem 7.2.6, we obtain

$$\begin{aligned} \left\| \sum_{n=1}^N \varepsilon_n T_{f_n} x_n \right\|_{L^2(\Omega; \gamma(H^*, X))} &= \mathbb{E} \left\| \sum_{n=1}^N \varepsilon_n (f_n \otimes x_n) \right\|_{L^2(\Omega; \gamma(H^*, X))} \\ &= \left\| \sum_{k=1}^K \gamma'_k \sum_{n=1}^N \varepsilon_n \langle f_n, h_k^* \rangle x_n \right\|_{L^2(\Omega; L^2(\Omega'; X))} \\ &= \left\| \sum_{n=1}^N \varepsilon_n \xi_n x_n \right\|_{L^2(\Omega'; L^2(\Omega; X))} \\ &\leq \left\| \sum_{n=1}^N \varepsilon_n \xi_n x_n \right\|_{L^r(\Omega'; L^q(\Omega; X))} \\ &\leq c_{q,X} \frac{q^{1/q} r}{r-q} \|\gamma\|_r \left\| \sum_{n=1}^N \varepsilon_n x_n \right\|_{L^q(\Omega; X)} \\ &\leq c_{q,X} \frac{q^{1/q} r}{r-q} \|\gamma\|_r \kappa_{q,2} \left\| \sum_{n=1}^N \varepsilon_n x_n \right\|_{L^2(\Omega; X)}. \end{aligned}$$

The claimed estimate follows with $r = 2q$ and $2q^{1/q} \leq 2e^{1/e} < 3$.

(1)⇒(2): This follows from Theorem 8.1.3.

(2)⇒(3): Let $(x_n)_{n=1}^N$ in X be arbitrary. Using the notation introduced in the proof of (3)⇒(1), it follows from Proposition 9.1.3 that

$$\begin{aligned} \mathbb{E}\mathbb{E}' \left\| \sum_{n=1}^N \gamma'_n \gamma_n x_n \right\|^2 &= \mathbb{E}\mathbb{E}' \left\| \sum_{k=1}^N \gamma'_k \sum_{n=1}^N \gamma_n \langle h_n, h_k^* \rangle x_n \right\|^2 \\ &= \mathbb{E} \left\| \sum_{n=1}^N \gamma_n T_{h_n} x_n \right\|_{\gamma(H^*, X)}^2 \leq \gamma(\mathcal{T}) \mathbb{E} \left\| \sum_{n=1}^N \gamma_n x_n \right\|^2. \end{aligned}$$

The result follows from this through an application of Proposition 7.5.18. □

The next result is an analogue of the R -boundedness result of Corollary 9.6.12(2) under the assumption that X has non-trivial type, or equivalently, that X is K -convex (see Theorem 7.4.23).

Theorem 9.6.14. *Let X be a Banach space and H be a Hilbert space. For each $h \in H$ define the operator $E_h : \gamma(H, X) \rightarrow X$ by*

$$E_h T := Th.$$

If X has non-trivial type $p > 1$, the family $\mathcal{E} = \{E_h : \|h\| \leq 1\}$ is R -bounded in $\mathcal{L}(\gamma(H, X), X)$ and

$$\mathcal{R}(\mathcal{E}) \leq 3 \|\gamma\|_{2p', \kappa_{p'}, 2\tau_{p, X}} K_{2, X},$$

where $K_{2, X}$ is the K -convexity constant of X .

Proof. By Proposition 7.1.13, X^* has finite cotype p' and $c_{p', X^*} \leq \tau_{p, X}$. Therefore, by Theorem 9.6.13 the set

$$\mathcal{T} := \{T_h : x^* \mapsto h \otimes x^*; \|h\|_H \leq 1\} \subseteq \mathcal{L}(X^*, \gamma(H^*, X^*))$$

is R -bounded, and

$$\mathcal{R}(\mathcal{T}) \leq 3 \|\gamma\|_{2p', \kappa_{p'}, 2c_{p', X^*}} \leq 3 \|\gamma\|_{2p', \kappa_{p'}, 2\tau_{p, X}}.$$

Using trace duality (see Theorem 9.1.24, which can be applied here since non-trivial type implies K -convexity by Theorem 7.4.23), we see that $\gamma(H^*, X^*) = \gamma(H, X)^*$ with equivalent norms. Moreover, from

$$\langle E_h S, x^* \rangle = \langle Sh, x^* \rangle = \langle S, h \otimes x^* \rangle = \langle S, T_h x^* \rangle, \quad S \in \gamma(H, X),$$

we infer that $E_h^* = T_h$, and hence $\mathcal{T} = \{E^* : E \in \mathcal{E}\} = \mathcal{E}^*$ in the notation of Proposition 8.4.1. From this proposition, we deduce that

$$\mathcal{R}(\mathcal{E}) \leq K_{2, X} \mathcal{R}(\mathcal{E}^*) = K_{2, X} \mathcal{R}(\mathcal{T}) \leq 3 \|\gamma\|_{2p', \kappa_{p'}, 2\tau_{p, X}} K_{2, X}.$$

□

Remark 9.6.15. The results of Corollary 9.6.12(2) and Theorem 9.6.14 are incomparable. Indeed, ℓ^1 satisfies Pisier’s contraction property but does not have non-trivial type (see Corollary 7.1.10 and Proposition 7.5.3), whereas the Schatten classes \mathcal{C}^p have non-trivial type for all $p \in (1, \infty)$ (see Proposition 7.1.11 but Pisier’s contraction property only for $p = 2$ (see Example 7.6.18).

It would be interesting to have a necessary and sufficient condition on the Banach space X in order that the family $\mathcal{E} = \{E_h : \|h\| \leq 1\}$ is R -bounded or γ -bounded. By considering finite rank operators one sees that the γ -boundedness of \mathcal{E} is equivalent to the assertion that for all $(a_{mn})_{m,n=1}^{M,N}$ with $\sum_{m=1}^M |a_{mn}|^2 \leq 1$ for all $1 \leq n \leq N$ and all $(x_{mn})_{m,n=1}^{M,N}$ in X we have

$$\mathbb{E} \left\| \sum_{n=1}^N \gamma_n \sum_{m=1}^M a_{mn} x_{mn} \right\|^2 \leq C^2 \mathbb{E} \left\| \sum_{m=1}^M \gamma'_m \sum_{n=1}^N \gamma_n x_{mn} \right\|^2.$$

Application to integral operators

As an application of the preceding results, we study the R -boundedness of families of integral operators associated with certain operator-valued functions $\phi : S \rightarrow \mathcal{L}(X, Y)$.

To be more precise, suppose that $\phi : S \rightarrow \mathcal{L}(X, Y)$ has the property that $\phi x : S \rightarrow Y$ is weakly in $L^2(S)$ for all $x \in X$. Then the Pettis integral operator $\mathbb{I}_{\phi x} : L^2(S) \rightarrow Y$ is well defined for every $x \in X$ (see Section 9.2). Under the stronger assumption that ϕx belongs to $\gamma(S; Y)$ for all $x \in X$ we have the following result.

Corollary 9.6.16. *Let (S, \mathcal{A}, μ) be a measure space and let X and Y be Banach spaces, Y having Pisier’s contraction property or non-trivial type. Let $\phi : S \rightarrow \mathcal{L}(X, Y)$ be a function with the property that $\phi x \in \gamma(S; Y)$ for all $x \in X$. Then for all $h \in L^2(S)$ the operator $V_{\phi, h} : X \rightarrow Y$ defined by*

$$V_{\phi, h} x := \mathbb{I}_{\phi x} h = \int_S h(s) \phi(s) x \, d\mu(s)$$

is bounded. Moreover, the family $\mathcal{V}_\phi = \{V_{\phi, h} : \|h\|_2 \leq 1\}$ is R -bounded, and

$$\mathcal{R}(\mathcal{V}_\phi) \leq \mathcal{R}(\mathcal{E}) \|x\| \mapsto \mathbb{I}_{\phi x} \|_{\mathcal{L}(X, \gamma(S; Y))} < \infty,$$

where \mathcal{E} is as in Theorem 9.6.14.

Proof. By Corollary 9.6.12(2) (if X has Pisier’s contraction property) or Theorem 9.6.14 (if X has non-trivial type), the family $\mathcal{E} = \{E_h : \|h\|_2 \leq 1\}$ is R -bounded in $\mathcal{L}(\gamma(S; Y), Y)$.

By assumption each operator $\mathbb{I}_{\phi x}$, as a bounded operator from $L^2(S)$ to X , belongs to $\gamma(S; Y)$. By the closed graph theorem, the mapping $I_\phi : X \rightarrow \gamma(S; Y)$ given by $I_\phi x := \mathbb{I}_{\phi x}$ is bounded. Since $V_{\phi, h} = E_h \circ I_\phi$, each operator $V_{\phi, h}$ is bounded and the R -boundedness of \mathcal{V}_ϕ follows from the R -boundedness of \mathcal{E} in $\mathcal{L}(\gamma(S; Y), Y)$. \square

As an application of this corollary we prove an R -boundedness result for Laplace transforms.

Example 9.6.17 (R-boundedness of Laplace transforms). Suppose that $\phi : \mathbb{R}_+ \rightarrow \mathcal{L}(X, Y)$ is strongly measurable and has the property that $\phi x \in \gamma(\mathbb{R}_+; Y)$ for all $x \in X$. Define, for $\lambda \in \mathbb{C}_+ = \{\lambda \in \mathbb{C} : \Re \lambda > 0\}$, the operators $\widehat{\phi}(\lambda) : X \rightarrow Y$ by

$$\widehat{\phi}(\lambda)x := \mathbb{I}_{\phi x}(e^{-\lambda \cdot}) = \int_0^\infty e^{-\lambda t} \phi(t)x \, dt.$$

Then the family

$$\{\sqrt{\Re(\lambda)}\widehat{\phi}(\lambda) : \lambda \in \mathbb{C}_+\} \subseteq \mathcal{L}(X, Y)$$

is R -bounded if Y has Pisier's contraction property or non-trivial type. This follows from Corollary 9.6.16 by observing that the functions $t \mapsto \sqrt{\Re(\lambda)} \exp(-\lambda t)$ have $L^2(\mathbb{R}_+)$ -norm one.

Proposition 9.7.21 will give a weaker form of the above result which holds for arbitrary Banach spaces Y .

Translation operators

Let $(S(t))_{t \in \mathbb{R}}$ denote the left-translation group on $L^p(\mathbb{R})$,

$$S(t)f(s) := f(s+t), \quad s, t \in \mathbb{R}.$$

In Proposition 8.1.16 it has been shown that $\{S(t) : t \in \mathbb{R}\}$ is R -bounded (or γ -bounded) on $L^p(\mathbb{R}; X)$ if and only if $p = 2$ and X is isomorphic to a Hilbert space. We will show now, on the space $\gamma(\mathbb{R}; X)$ both R -boundedness and γ -boundedness of the translation group are characterised in terms of Pisier's contraction property:

Proposition 9.6.18. *Let X be a non-zero Banach space and let $(S(t))_{t \in \mathbb{R}}$ denote the left-translation group on $L^2(\mathbb{R})$. The following assertions are equivalent:*

- (1) *the family of extensions $(S(t) \otimes I_X)_{t \in \mathbb{R}}$ is R -bounded on $\gamma(\mathbb{R}; X)$;*
- (2) *the family of extensions $(S(t) \otimes I_X)_{t \in \mathbb{R}}$ is γ -bounded on $\gamma(\mathbb{R}; X)$;*
- (3) *X has Pisier's contraction property.*

Proof. Let us write $\widetilde{S}(t) = S(t) \otimes I_X$ for brevity.

(1) \Rightarrow (2): This follows from Theorem 8.1.3.

(2) \Rightarrow (3): Suppose that $\mathcal{S}_X := (\widetilde{S}(t))_{t \in \mathbb{R}}$ is γ -bounded with constant C . Let $(\gamma'_n)_{n \geq 1}$ and $(\gamma''_n)_{n \geq 1}$ be Gaussian sequences on probability spaces (Ω', \mathbb{P}') and (Ω'', \mathbb{P}'') respectively, and let $(\gamma_{mn})_{m, n \geq 1}$ be a doubly indexed Gaussian

sequence on a probability space (Ω, \mathbb{P}) . Let $(x_{mn})_{m,n=1}^{M,N}$ a doubly indexed sequence in X . According to Corollary 7.5.19 it suffices to show that

$$\mathbb{E} \left\| \sum_{m=1}^M \sum_{n=1}^N \gamma_{mn} x_{mn} \right\|^2 \approx_X \mathbb{E}' \mathbb{E}'' \left\| \sum_{m=1}^M \sum_{n=1}^N \gamma'_m \gamma''_n x_{mn} \right\|^2. \quad (9.37)$$

Choose an orthonormal basis $(h_n)_{n \geq 1}$ for $L^2(0, 1)$ and extend each h_n by zero outside the interval $(0, 1)$. For each $m \in \mathbb{Z}$ and $n \geq 1$ let $h_n^m \in L^2(\mathbb{R})$ be defined by $h_n^m(t) = h_n(t + m) = S(m)h_n(t)$. Then $(h_n^m)_{m \in \mathbb{Z}, n \geq 1}$ is an orthonormal basis for $L^2(\mathbb{R})$.

Step 1 – In this step we prove the inequality “ \lesssim_X ” in (9.37).

Put $f_m := \sum_{n=1}^N h_n \otimes x_{mn}$. Since $\tilde{S}(m)f_m = \sum_{n=1}^N S(m)h_n \otimes x_{mn} = \sum_{n=1}^N h_n^m \otimes x_{mn}$,

$$\begin{aligned} \mathbb{E}' \left\| \sum_{m=1}^M \gamma'_m \tilde{S}(m)f_m \right\|_{\gamma(\mathbb{R}; X)}^2 &= \mathbb{E}' \left\| \sum_{m=1}^M \gamma'_m \sum_{n=1}^N h_n^m \otimes x_{mn} \right\|_{\gamma(\mathbb{R}; X)}^2 \\ &= \mathbb{E}' \mathbb{E} \left\| \sum_{m=1}^M \sum_{n=1}^N \gamma'_m \gamma_{mn} x_{mn} \right\|^2. \end{aligned}$$

By the same argument,

$$\mathbb{E}' \left\| \sum_{m=1}^M \gamma'_m f_m \right\|_{\gamma(\mathbb{R}; X)}^2 = \mathbb{E}' \mathbb{E}'' \left\| \sum_{m=1}^M \sum_{n=1}^N \gamma'_m \gamma''_n x_{mn} \right\|^2.$$

Therefore, by the γ -boundedness of \mathcal{S}_X ,

$$\mathbb{E}' \mathbb{E} \left\| \sum_{m=1}^M \sum_{n=1}^N \gamma'_m \gamma_{mn} x_{mn} \right\|^2 \leq \mathcal{R}(\mathcal{S}_X)^2 \mathbb{E}' \mathbb{E}'' \left\| \sum_{m=1}^M \sum_{n=1}^N \gamma'_m \gamma''_n x_{mn} \right\|^2. \quad (9.38)$$

By Corollary 6.1.17 and symmetry, the left hand side satisfies

$$\begin{aligned} \mathbb{E}' \mathbb{E} \left\| \sum_{m=1}^M \sum_{n=1}^N \gamma'_m \gamma_{mn} x_{mn} \right\|^2 &\geq \|\gamma\|_1^2 \mathbb{E}' \mathbb{E} \left\| \sum_{m=1}^M \sum_{n=1}^N \varepsilon'_m \gamma_{mn} x_{mn} \right\|^2 \\ &= \|\gamma\|_1^2 \mathbb{E} \left\| \sum_{m=1}^M \sum_{n=1}^N \gamma_{mn} x_{mn} \right\|^2. \end{aligned}$$

Substituting into (9.38), we have proved that

$$\alpha_{2, X}^{\gamma, +} \leq \|\gamma\|_1^{-1} \mathcal{R}(\mathcal{S}_X).$$

Step 2 – Next we prove the inequality “ \gtrsim_X ” in (9.37). Put $f_m := \sum_{n=1}^N h_n^m \otimes x_{mn}$. Then

$$\begin{aligned} \mathbb{E}' \left\| \sum_{m=1}^M \gamma'_m \tilde{S}(-m) f_m \right\|_{\gamma(\mathbb{R}; X)}^2 &= \mathbb{E}' \left\| \sum_{m=1}^M \gamma'_m \sum_{n=1}^N h_n \otimes x_{mn} \right\|_{\gamma(\mathbb{R}; X)}^2 \\ &= \mathbb{E}' \mathbb{E} \left\| \sum_{m=1}^M \sum_{n=1}^N \gamma'_m \gamma''_n x_{mn} \right\|^2. \end{aligned}$$

On the other hand,

$$\mathbb{E}' \left\| \sum_{m=1}^M \gamma'_m f_m \right\|_{\gamma(\mathbb{R}; X)}^2 = \mathbb{E}' \mathbb{E} \left\| \sum_{m=1}^M \sum_{n=1}^N \gamma'_m \gamma_{mn} x_{mn} \right\|^2.$$

Therefore, by the γ -boundedness of \mathcal{S}_X ,

$$\mathbb{E}' \mathbb{E} \left\| \sum_{m=1}^M \sum_{n=1}^N \gamma'_m \gamma''_n x_{mn} \right\|^2 \leq \mathcal{R}(\mathcal{S}_X)^2 \mathbb{E}' \mathbb{E} \left\| \sum_{m=1}^M \sum_{n=1}^N \gamma'_m \gamma_{mn} x_{mn} \right\|^2. \quad (9.39)$$

Applying (9.38) with $N = 1$, we have

$$\mathbb{E}' \mathbb{E} \left\| \sum_{m=1}^M \gamma'_m \gamma_{m1} x_{m1} \right\|^2 \leq \mathcal{R}(\mathcal{S}_X)^2 \mathbb{E}' \left\| \sum_{m=1}^M \gamma'_m x_{m1} \right\|^2.$$

By Proposition 7.5.18 this implies that X has finite cotype. Therefore, by Corollary 7.2.10 we see that $(\gamma'_m)_{m \geq 1}$ can be replaced by a Rademacher sequence $(\varepsilon'_m)_{m \geq 1}$, and then we can use symmetry as in Step 1:

$$\begin{aligned} \mathbb{E}' \mathbb{E}' \left\| \sum_{m=1}^M \sum_{n=1}^N \gamma'_m \gamma_{mn} x_{mn} \right\|^2 &\lesssim_X \mathbb{E}' \mathbb{E}' \left\| \sum_{m=1}^M \sum_{n=1}^N \varepsilon'_m \gamma_{mn} x_{mn} \right\|^2 \\ &= \mathbb{E}' \left\| \sum_{m=1}^M \sum_{n=1}^N \gamma_{mn} x_{mn} \right\|^2. \end{aligned} \quad (9.40)$$

Now the assertion of Step 2 follows from (9.39) and (9.40). (Note that, in contrast to Step 1, the dependence of the constant $\alpha_{2, \overline{X}}'$ on $\mathcal{R}(\mathcal{S})$ given by this argument is rather implicit, due to the application of Proposition 7.5.18 and Corollary 7.2.10.)

(3) \Rightarrow (1): This is a consequence of Theorem 9.6.10. \square

9.7 Function space embeddings

Even if $L^2(0, 1; X)$ may fail to embed into $\gamma(0, 1; X)$ in general, sufficiently smooth functions do belong to $\gamma(0, 1; X)$. A similar phenomenon occurs in Proposition 8.5.7, where we derived a sufficient condition for R -boundedness using smoothness conditions. In this section we study the embedding of various classical function spaces into $\gamma(S; X)$.

9.7.a Embedding Sobolev spaces

We begin with some simple embedding results valid for arbitrary Banach spaces X .

Proposition 9.7.1. *Let $-\infty < a < b < \infty$. If $\phi \in W^{1,1}(a', b; X)$ for all $a < a' < b$ and satisfies*

$$\int_a^b (s-a)^{1/2} \|\phi'(s)\| \, ds < \infty,$$

then $\phi \in \gamma(a, b; X)$ and

$$\|\phi\|_{\gamma(a,b;X)} \leq (b-a)^{1/2} \|\phi(b)\| + \int_a^b (s-a)^{1/2} \|\phi'(s)\| \, ds.$$

Proof. The condition on ϕ' implies that it is integrable on every interval (a', b) with $a < a' < b$. Put $\psi(s, t) := \mathbf{1}_{(t,b)}(s)\phi'(s)$ for $s, t \in (a, b)$. Then

$$\phi(t) = \phi(b) - \int_a^b \psi(s, t) \, ds$$

for all $t \in (a, b)$. For all $s \in (a, b)$ the function $t \mapsto \psi(s, t) = \mathbf{1}_{(t,b)}(s)\phi'(s) = \mathbf{1}_{(a,s)}(t)\phi'(s)$ is in $\gamma(a, b; X)$ and

$$\|\mathbf{1}_{(a,s)}(\cdot)\phi'(s)\|_{\gamma(a,b;X)} = \|\mathbf{1}_{(a,s)}\|_2 \|\phi'(s)\| = (s-a)^{1/2} \|\phi'(s)\|.$$

It follows that the $\gamma(a, b; X)$ -valued function $s \mapsto \psi(s, \cdot)$ is Bochner integrable. We find that $\phi \in \gamma(a, b; X)$ and

$$\begin{aligned} \|\phi\|_{\gamma(a,b;X)} &\leq (b-a)^{1/2} \|\phi(b)\| + \int_a^b \|\psi(s, \cdot)\|_{\gamma(a,b;X)} \, ds \\ &= (b-a)^{1/2} \|\phi(b)\| + \int_a^b (s-a)^{1/2} \|\phi'(s)\| \, ds. \end{aligned}$$

□

The proposition implies that every $f \in W^{1,1}(a, b; X)$ defines an element of $\gamma(a, b; X)$, i.e., we have a natural inclusion $W^{1,1}(a, b; X) \hookrightarrow \gamma(a, b; X)$, and

$$\|\phi\|_{\gamma(a,b;X)} \leq (b-a)^{1/2} \|\phi(b)\| + (b-a)^{1/2} \int_a^b \|\phi'(s)\| \, ds$$

In the converse direction we have the following result.

Proposition 9.7.2. *Let $-\infty < a < b < \infty$. If f is absolutely continuous, $f \in \gamma(a, b; X)$ and $f' \in \gamma(a, b; X)$, then $f \in C^{\frac{1}{2}}([a, b]; X)$ and*

$$\begin{aligned} \|f\|_{C([a,b];X)} &\leq (b-a)^{-1/2} \|f\|_{\gamma(a,b;X)} + (b-a)^{1/2} \|f'\|_{\gamma(a,b;X)}, \\ [f]_{C^{\frac{1}{2}}([a,b];X)} &\leq \|f'\|_{\gamma(a,b;X)}. \end{aligned}$$

Proof. For $a \leq s < t \leq b$, $f(t) = f(s) + \int_s^t f'(r) dr = f(s) + \mathbb{I}_{f'} \mathbf{1}_{[s,t]}$. Multiplying by $\mathbf{1}_{(a,b)}(s)$ and integrating over s we find that

$$f(t)(b-a) = \mathbb{I}_f(\mathbf{1}_{[a,b]}) + \int_a^b \mathbb{I}_{f'} \mathbf{1}_{[s,t]} ds.$$

Therefore,

$$\|f(t)\| \leq (b-a)^{-1/2} \|\mathbb{I}_f\|_{\mathcal{L}(L^2(a,b),X)} + (b-a)^{1/2} \|\mathbb{I}_{f'}\|_{\mathcal{L}(L^2(a,b),X)}.$$

Similarly,

$$\|f(t) - f(s)\| = \|\mathbb{I}_{f'} \mathbf{1}_{[s,t]}\| \leq (t-s)^{1/2} \|\mathbb{I}_{f'}\|_{\mathcal{L}(L^2(a,b),X)}.$$

□

The effect of type

The next result presents a refinement of the proposition in the presence of type $p \in [1, 2)$. The case $p = 2$ has already been considered in Theorem 9.2.10.

Recall that for $s \in (0, 1)$ and $p \in [1, \infty)$ the Sobolev norm $\|\cdot\|_{W^{s,p}(a,b;X)}$ is given by

$$\|f\|_{W^{s,p}(a,b;X)} = \|f\|_{L^p(a,b;X)} + [f]_{W^{s,p}(a,b;X)},$$

where

$$[f]_{W^{s,p}(a,b;X)} = \left(\int_a^b \int_a^b \frac{\|f(x) - f(y)\|^p}{|x-y|^{sp+1}} dx dy \right)^{1/p}.$$

Theorem 9.7.3. *Let X be a Banach space, let $p \in [1, 2)$ and $s := \frac{1}{p} - \frac{1}{2}$. Let $I \subseteq \mathbb{R}$ be a non-empty open interval. Then*

$$W^{s,p}(I; X) \hookrightarrow \gamma(I; X)$$

if and only if X has type p . In this situation we have

$$\|f\|_{\gamma(I;X)} \leq 5\tau_{p,X}^\gamma (|I|^{-s} \|f\|_{L^p(a,b;X)} + [f]_{W^{s,p}(a,b;X)}).$$

In case $|I| = \infty$ we use the convention $|I|^{-s} = 0$.

Proof. Let us first assume that X has type p .

Step 1: In this step we consider the unit interval $I = (0, 1)$. Let $\mathbb{I}_f : L^\infty(0, 1) \rightarrow X$ be given by

$$\mathbb{I}_f \phi = \int_0^1 \phi(t) f(t) dt.$$

We will show that $\mathbb{I}_f \in \gamma(0, 1; X)$. To this end we estimate the radonifying norm in terms of the Haar basis $(h_n)_{n \geq 1} = (\mathbf{1}_{(0,1)}, \phi_{jk})_{0 \leq j < \infty, 1 \leq k \leq 2^j}$ of $(0, 1)$ (see Section 9.1.h). For $1 \leq n_1 \leq n_2 < \infty$ we have

$$\left\| \sum_{n=n_1}^{n_2} \gamma_n \mathbb{I}_f h_n \right\|_{L^p(\Omega; X)} \leq \tau_{p, X} \left(\sum_{n=n_1}^{n_2} \|\mathbb{I}_f h_n\|^p \right)^{1/p}.$$

Moreover, if $2^{N_1} < n_1 \leq n_2 \leq 2 \cdot 2^{N_2}$, then

$$\begin{aligned} \sum_{n=n_1}^{n_2} \|\mathbb{I}_f h_n\|^p &\leq \sum_{j=N_1}^{N_2} \sum_{k=1}^{2^j} \|\mathbb{I}_f \phi_{jk}\|^p \\ &= \sum_{j=N_1}^{N_2} 2^{jp/2} \sum_{k=1}^{2^j} \left\| \int_{(k-1)2^{-j}}^{(k-\frac{1}{2})2^{-j}} f(t+2^{-j-1}) - f(t) dt \right\|^p \\ &\leq \sum_{j=N_1}^{N_2} 2^{\frac{1}{2}jp+(j+1)(1-p)} \sum_{k=1}^{2^j} \int_{(k-1)2^{-j}}^{(k-\frac{1}{2})2^{-j}} \|f(t+2^{-j-1}) - f(t)\|^p dt \\ &\leq \sum_{j=N_1}^{N_2} 2^{jsp} \int_0^{1-2^{-j-1}} \|f(t+2^{-j-1}) - f(t)\|^p dt, \end{aligned}$$

using that $s = \frac{1}{p} - \frac{1}{2}$ and $2^{1-p} \leq 1$ in the last step.

Introducing an extra term and integral we can write

$$\begin{aligned} &\int_0^{1-2^{-j-1}} \|f(t+2^{-j-1}) - f(t)\|^p dt \\ &= 2^{j+3} \int_0^{1-2^{-j-1}} \int_{2^{-j-3}}^{2^{-j-2}} \|f(t+2^{-j-1}) - f(t+h) + f(t+h) - f(t)\|^p dh dt. \end{aligned}$$

Therefore, by the triangle inequality,

$$\left(\sum_{j=N_1}^{N_2} \sum_{k=1}^{2^j} \|\mathbb{I}_f \phi_{jk}\|^p \right)^{1/p} \leq T_1 + T_2,$$

where T_1 and T_2 are given by

$$\begin{aligned} T_1^p &= 8 \sum_{j=N_1}^{N_2} 2^{j(sp+1)} \int_0^{1-2^{-j-1}} \int_{2^{-j-3}}^{2^{-j-2}} \|f(t+2^{-j-1}) - f(t+h)\|^p dh dt, \\ T_2^p &= 8 \sum_{j=N_1}^{N_2} 2^{j(sp+1)} \int_0^{1-2^{-j-1}} \int_{2^{-j-3}}^{2^{-j-2}} \|f(t+h) - f(t)\|^p dh dt. \end{aligned}$$

To estimate T_1 we make a substitution in t and then one in h ,

$$T_1^p = 8 \sum_{j=N_1}^{N_2} \int_{2^{-j-1}}^1 \int_{-3 \cdot 2^{-j-3}}^{-2^{-j-2}} 2^{j(sp+1)} \|f(t) - f(t+h)\|^p dh dt$$

$$\begin{aligned}
&\leq 3 \sum_{j=N_1}^{N_2} \int_{2^{-j-1}}^1 \int_{-2^{-j-1}}^{-2^{-j-2}} \frac{\|f(t) - f(t+h)\|^p}{|h|^{sp+1}} dh dt \quad \left(2^j \leq \frac{3}{8}|h|^{-1}\right) \\
&\leq 3 \iint_{\Delta_{2^{-N_1-1}}} \frac{\|f(t) - f(u)\|^p}{|t-u|^{sp+1}} dt du, \quad \Delta_\delta := \{(t, u) \in [0, 1]^2 : |t-u| \leq \delta\}.
\end{aligned}$$

The term T_2 can be estimated as

$$\begin{aligned}
T_2^p &= 8 \sum_{j=N_1}^{N_2} \int_0^{1-2^{-j-1}} \int_{2^{-j-3}}^{2^{-j-2}} 2^{j(sp+1)} \|f(t+h) - f(t)\|^p dh dt \\
&\leq 2 \sum_{j=N_1}^{N_2} \int_0^{1-2^{-j-1}} \int_{2^{-j-3}}^{2^{-j-2}} \frac{\|f(t+h) - f(t)\|^p}{|h|^{sp+1}} dh dt \quad \left(2^j \leq \frac{1}{4}|h|^{-1}\right) \\
&\leq 2 \iint_{\Delta_{2^{-N_1-2}}} \frac{\|f(t) - f(u)\|^p}{|t-u|^{sp+1}} dt du.
\end{aligned}$$

Since $f \in W^{s,p}(0, 1; X)$, both terms converge to zero as $N_1 \rightarrow \infty$. Therefore, by Theorem 9.1.17 we find $f \in \gamma(0, 1; X)$. Moreover, taking $N_1 = 0$ and letting $N_2 \rightarrow \infty$, and taking into account the term

$$\|\mathbb{I}_f \mathbf{1}_{(0,1)}\| \leq \|f\|_{L^1(0,1;X)} \leq \|f\|_{L^p(0,1;X)}$$

corresponding to $h_1 = \mathbf{1}_{(0,1)}$, it follows that

$$\begin{aligned}
\|f\|_{\gamma^p(0,1;X)} &\leq \tau_{p,X}^\gamma (\|\mathbb{I}_f \mathbf{1}_{(0,1)}\| + T_1 + T_2) \\
&\leq \tau_{p,X}^\gamma (\|f\|_{L^p(0,1;X)} + (3+2)[f]_{W^{s,p}(0,1;X)}) \\
&\leq 5\tau_{p,X}^\gamma \|f\|_{W^{s,p}(0,1;X)}.
\end{aligned}$$

Step 2: Assume next that $I = (a, b)$ is a bounded interval. Let $f \in W^{s,p}(I; X)$ be arbitrary. Let $g : (0, 1) \rightarrow X$ be given by $g(t) = f(a + t(b-a))$. Then $g \in W^{s,p}(0, 1; X)$ and

$$[g]_{W^{s,p}(0,1;X)} = |I|^{-1/2} [f]_{W^{s,p}(I;X)}, \quad \|g\|_{L^p(0,1;X)} = |I|^{-1/p} \|f\|_{L^p(I;X)},$$

and

$$\|g\|_{\gamma(0,1;X)} = |I|^{-1/2} \|f\|_{\gamma(I;X)}.$$

Therefore, by the previous step we find

$$\begin{aligned}
\|f\|_{\gamma(I;X)} &= |I|^{1/2} \|g\|_{\gamma(0,1;X)} \\
&\leq 5\tau_{p,X}^\gamma |I|^{1/2} (\|g\|_{L^p(0,1;X)} + [g]_{W^{s,p}(0,1;X)}) \\
&= 5\tau_{p,X}^\gamma (|I|^{\frac{1}{2}-\frac{1}{p}} \|f\|_{L^p(I;X)} + [f]_{W^{s,p}(I;X)}).
\end{aligned}$$

Step 3: If I is an infinite intervals, let $f_n := f|_{I \cap (-n, n)}$ and $f_{m,n}^\pm := f|_{I \cap \pm(m, n)}$ for $0 \leq m < n < \infty$. Then by what has already been proved and (9.19) we obtain

$$\begin{aligned} \|\mathbf{1}_{(-n,n)}f - \mathbf{1}_{(-m,m)}f\|_{\gamma(\mathbb{R}_+;X)} &\leq \sum_{\sigma=\pm} \|f_{m,n}^\sigma\|_{\gamma(\sigma(m,n);X)} \\ &\leq 5\tau_{p,X}^\gamma \sum_{\sigma=\pm} \left((n-m)^{\frac{1}{2}-\frac{1}{p}} \|f_{n,m}^\sigma\|_{L^p(\sigma(m,n);X)} + [f_{m,n}^\sigma]_{W^{\alpha,p}(\sigma(m,n);X)} \right). \end{aligned}$$

As $m, n \rightarrow \infty$, the latter tends to zero by the dominated convergence theorem. This proves that $(\mathbf{1}_{I \cap (-n,n)}f)_{n \geq 1}$ is a Cauchy sequence in $\gamma(I; X)$. Since $\mathbf{1}_{I \cap (-n,n)}\langle f, x^* \rangle \rightarrow \langle f, x^* \rangle$ pointwise it follows from Lemma 9.2.7 that $f \in \gamma(I; X)$ and $\mathbf{1}_{I \cap (-n,n)}f \rightarrow f$ in $\gamma(\mathbb{R}_+; X)$. Taking $m = 0$ in the above norm estimate and letting $n \rightarrow \infty$ gives

$$\|f\|_{\gamma(I;X)} \leq 5\tau_{p,X}^\gamma [f]_{W^{s,p}(I;X)}.$$

The converse result: Assume that we have a continuous embedding $W^{s,p}(I; X) \hookrightarrow \gamma(I; X)$. We must show that X has type p . We will only consider the case of a bounded interval I , as the other cases can be done in a similar way. By using translations and dilations as in Step 2 we may assume that $I = (0, 1)$.

Let C be the norm of the embedding mapping $W^{s,p}(0, 1; X) \hookrightarrow \gamma(0, 1; X)$. Let $(x_n)_{n=1}^N$ be an arbitrary sequence in X . Let $t_j = j/(2N)$ for $j = 0, \dots, 2N$. Let $f = \sum_{n=1}^N \mathbf{1}_{(t_{2n-2}, t_{2n-1})} \otimes x_n$ and extend this function identically zero outside $(0, 1)$. Clearly,

$$\|f\|_{L^p(I;X)} = (2N)^{-1/p} \left(\sum_{n=1}^N \|x_n\|^p \right)^{1/p}.$$

Moreover,

$$\begin{aligned} [f]_{W^{s,p}(0,1;X)}^p &= 2 \int_0^1 \int_y^1 \frac{\|f(y) - f(x)\|^p}{|y-x|^{sp+1}} dx dy \\ &= 2 \int_0^1 \int_0^{1-y} \frac{\|f(y) - f(y+h)\|^p}{h^{sp+1}} dh dy \\ &\leq 2 \int_0^1 \int_0^1 \frac{\|f(y) - f(y+h)\|^p}{h^{sp+1}} dy dh =: 2(T_1^p + T_2^p). \end{aligned}$$

Here T_1^p and T_2^p are given by the integrals over $(0, 1) \times (0, 1/(2N))$ and $h \in (0, 1) \times (1/(2N), 1)$ respectively.

By the triangle inequality,

$$\begin{aligned} T_2 &\leq \left(\int_{1/(2N)}^1 \int_0^1 \frac{\|f(y)\|^p}{h^{sp+1}} dy dh \right)^{1/p} + \left(\int_{1/(2N)}^1 \int_0^1 \frac{\|f(y+h)\|^p}{h^{sp+1}} dy dh \right)^{1/p} \\ &\leq C_p ((2N)^{sp} - 1)^{1/p} \|f\|_{L^p(I;X)} \leq C_p (2N)^{-1/2} \left(\sum_{n=1}^N \|x_n\|^p \right)^{1/p}. \end{aligned}$$

Turning to T_1 , for $0 < h \leq 1/(2N)$, we have

$$f(\cdot + h) - f(\cdot) = \sum_{n=1}^N (\mathbf{1}_{(t_{2n-2}-h, t_{2n-2}]} - \mathbf{1}_{(t_{2n-1}-h, t_{2n-1}]}) \otimes x_n.$$

Therefore, $\|f(\cdot + h) - f(\cdot)\|_{L^p(0,1;X)}^p \leq 2h \sum_{n=1}^N \|x_n\|^p$ and it follows that

$$\begin{aligned} T_1^p &= \int_0^{(2N)^{-1}} \frac{\|f(\cdot) - f(\cdot + h)\|_{L^p(0,1;X)}^p}{h^{sp+1}} dh \\ &\leq \left(\int_0^{(2N)^{-1}} 2h^{-sp} dh \right) \sum_{n=1}^N \|x_n\|^p = C_p (2N)^{-p/2} \sum_{n=1}^N \|x_n\|^p. \end{aligned}$$

We conclude that

$$\|f\|_{W^{s,p}(0,1;X)} \leq C_p N^{-1/2} \left(\sum_{n=1}^N \|x_n\|^p \right)^{1/p}.$$

(The numerical value of C_p may be different from line to line). Using Example 9.2.4 it follows that

$$\begin{aligned} \left\| \sum_{n=1}^N \gamma_n x_n \right\|_{L^p(\Omega;X)} &= (2N)^{1/2} \|f\|_{\gamma^p(I;X)} \\ &\leq C(2N)^{1/2} \|f\|_{W^{s,p}(0,1;X)} \\ &\leq C((2N)^{-s} + C_p) \left(\sum_{n=1}^N \|x_n\|^p \right)^{1/p}. \end{aligned}$$

Since $(2N)^{-s} \leq 1$ this shows that X has type p with $\tau_{p,X}^\gamma \leq C(1 + C_p)$. \square

9.7.b Embedding Hölder spaces

As an immediate consequence of Theorem 9.7.3 we obtain the following result for Hölder continuous functions.

Corollary 9.7.4. *Let X be a Banach space with type $1 \leq p < 2$. If I is an interval of finite length, then for all $\alpha > \frac{1}{p} - \frac{1}{2}$ we have a continuous inclusion*

$$C^\alpha(I; X) \hookrightarrow \gamma(I; X).$$

The following example shows that for $X = \ell^p$ with $1 \leq p < 2$ the above result fails at the critical exponent $\alpha = \frac{1}{p} - \frac{1}{2}$.

Example 9.7.5. Let $1 \leq p < 2$ and $0 < \alpha \leq \frac{1}{2}$ satisfy $\alpha = \frac{1}{p} - \frac{1}{2}$. There exists a function $f \in C^\alpha([0, 1]; \ell^p)$ for which the associated integral operator $\mathbb{I}_f : L^2(0, 1) \rightarrow \ell^p$ does not belong to $\gamma(0, 1; \ell^p)$.

Proof. For $j \geq 0$ and $k = 1, \dots, 2^j$ let φ_{jk} be the *Schauder functions* on $[0, 1]$, i.e.,

$$\varphi_{jk}(t) = \int_0^t \phi_{jk}(s) ds,$$

where ϕ_{jk} are the Haar functions on $(0, 1)$ as defined before the proof of Corollary 9.1.27. Let $(e_n)_{n \geq 1}$ denote the standard basis in ℓ^p . For $n = 1, 2, \dots$ let $f_n : [0, 1] \rightarrow \ell^p$ be defined as

$$f_n(t) = \sum_{j=0}^n \sum_{k=1}^{2^j} 2^{(1-1/p)j} \varphi_{jk}(t) e_{2^j+k}.$$

The function $f_n \in L^2(0, 1) \otimes \ell^p$ belongs to $\gamma(0, 1; \ell^p)$, and by the square function estimate of Proposition 9.3.2 we have

$$\begin{aligned} \|\mathbb{I}_{f_n}\|_{\gamma^p(L^2(0,1), \ell^p)}^p &= \|\gamma\|_p^p \sum_{j=0}^n \sum_{k=1}^{2^j} 2^{(p-1)j} \left(\int_0^1 \varphi_{nk}^2(t) dt \right)^{p/2} \\ &= \|\gamma\|_p^p \sum_{j=0}^n \sum_{k=1}^{2^j} 2^{(p-1)j} \left(\frac{2^{-2j-2}}{3} \right)^{p/2} = \|\gamma\|_p^p \frac{n}{12^{p/2}}. \end{aligned}$$

Therefore

$$\|\mathbb{I}_{f_n}\|_{\gamma^p(L^2(0,1), \ell^p)} = K_p n^{1/p} \quad (9.41)$$

with $K_p = \|\gamma\|_p / \sqrt{12}$.

We claim that f_n is α -Hölder continuous and

$$\|f_n\|_{C^\alpha([0,1]; \ell^p)} = \sup_{t \in [0,1]} \|f_n(t)\|_{\ell^p} + \sup_{0 \leq s < t \leq 1} \frac{\|f_n(t) - f_n(s)\|_{\ell^p}}{(t-s)^\alpha} \leq C_p, \quad (9.42)$$

where C_p is a constant independent of n . Indeed, for each $t \in [0, 1]$, we have

$$\begin{aligned} \|f_n(t)\|_{\ell^p} &= \left(\sum_{j=0}^n \sum_{k=1}^{2^j} 2^{(p-1)j} |\varphi_{jk}(t)|^p \right)^{1/p} \leq \left(\sum_{j=0}^n 2^{(p-1)j} 2^{-(j+2)p/2} \right)^{1/p} \\ &= \frac{1}{2} \left(\sum_{j=0}^n 2^{-(1-p/2)j} \right)^{1/p} \leq \frac{1}{2} \left(\frac{2^{1-p/2}}{2^{1-p/2} - 1} \right)^{1/p}. \end{aligned}$$

Now let $0 \leq s < t \leq 1$. Let $j_0 \geq 1$ be the largest integer for which there exists an integer $1 \leq k \leq 2^{j_0}$ such that $s, t \in [(k-1)2^{-j_0}, (k+1)2^{-j_0}]$. Then

$$(k-1)2^{-j_0} \leq s \leq k2^{-j_0} \leq t \leq (k+1)2^{-j_0}. \quad (9.43)$$

Indeed, otherwise both s and t are contained in either the left or the right half of the interval $[(k-1)2^{-j_0}, (k+1)2^{-j_0}]$ and one could replace j_0 with $j_0 + 1$. Also,

$$2^{-j_0-1} \leq t - s \leq 2^{-j_0+1}.$$

The upper estimate is clear. For the lower estimate assume that $t - s < 2^{-j_0-1}$. Then $t - k2^{-j_0} < 2^{-j_0-1}$ and $k2^{-j_0} - s < 2^{-j_0-1}$. Therefore, $t, s \in [(k - \frac{1}{2})2^{-j_0}, (k + \frac{1}{2})2^{-j_0}] = [(2k - 1)2^{-j_0-1}, (2k + 1)2^{-j_0-1}]$. This contradicts the choice of j_0 .

Now for each $0 \leq j \leq j_0$ let k_j be the unique integer such that $s \in [(k_j - 1)2^{-j}, k_j 2^{-j}]$. Two cases can occur: (i) $t \in [(k_j - 1)2^{-j}, k_j 2^{-j}]$ or (ii) $t \in [k_j 2^{-j}, (k_j + 1)2^{-j}]$.

Since φ_{jk_j} is supported on the interval $[\frac{k_j-1}{2^j}, \frac{k_j}{2^j}]$ and satisfies $|\varphi'| = 2^{j/2}$ in its interior, in case (i) it follows that

$$|\varphi_{jk_j}(t) - \varphi_{jk_j}(s)| \leq 2^{j/2}(t - s) \leq 2^{j/2}2^{-(j_0+1)(1-\alpha)}(t - s)^\alpha.$$

In case (ii) it follows that $\varphi_{jk_j}(k_j 2^{-j}) = 0 = \varphi_{jk_j}(t)$ and

$$\begin{aligned} |\varphi_{jk_j}(t) - \varphi_{jk_j}(s)| &= |\varphi_{jk_j}(k_j 2^{-j}) - \varphi_{jk_j}(s)| \leq 2^{j/2}(k_j 2^{-j} - s) \\ &\leq 2^{j/2}(t - s) \leq 2^{j/2}2^{-(j_0+1)(1-\alpha)}(t - s)^\alpha, \end{aligned}$$

and in the same way

$$\begin{aligned} |\varphi_{jk_{j+1}}(t) - \varphi_{jk_{j+1}}(s)| &= |\varphi_{jk_{j+1}}(t) - \varphi_{jk_{j+1}}(k_j 2^{-j})| \\ &\leq 2^{j/2}2^{-(j_0+1)(1-\alpha)}(t - s)^\alpha. \end{aligned}$$

For $k \notin \{k_j, k_j + 1\}$ the support of φ_{jk} is disjoint from $(\frac{k_j-1}{2^j}, \frac{k_j+1}{2^j})$ and we infer from (9.43) that $\varphi_{jk}(s) = \varphi_{jk}(t) = 0$.

For $j_0 < j \leq n$ let $\ell_j < m_j$ be the unique integers such that $s \in [(\ell_j - 1)2^{-j}, \ell_j 2^{-j}]$ and $t \in [(m_j - 1)2^{-j}, m_j 2^{-j}]$. Then

$$\begin{aligned} |\varphi_{j\ell_j}(t) - \varphi_{j\ell_j}(s)| &= |\varphi_{j\ell_j}(s)| \leq 2^{-\frac{1}{2}j-1}, \\ |\varphi_{jm_j}(t) - \varphi_{jm_j}(s)| &= |\varphi_{jm_j}(t)| \leq 2^{-\frac{1}{2}j-1}. \end{aligned}$$

As in case (i) for the remaining $k \notin \{\ell_j, m_j\}$ we have $\varphi_{jk}(s) = \varphi_{jk}(t) = 0$.

We conclude that

$$\begin{aligned} &\|f_n(t) - f_n(s)\|^p \\ &\leq \sum_{j=0}^{j_0} \sum_{k=1}^{2^j} 2^{(p-1)j} |\varphi_{jk}(t) - \varphi_{jk}(s)|^p + \sum_{j=j_0+1}^n \sum_{k=1}^{2^j} 2^{(p-1)j} |\varphi_{jk}(t) - \varphi_{jk}(s)|^p \\ &= \sum_{j=0}^{j_0} \sum_{k \in \{k_j, k_j+1\}} 2^{(p-1)j} |\varphi_{jk}(t) - \varphi_{jk}(s)|^p \\ &\quad + \sum_{j=j_0+1}^n \sum_{k \in \{\ell_j, m_j\}} 2^{(p-1)j} |\varphi_{jk}(t) - \varphi_{jk}(s)|^p \end{aligned}$$

$$\begin{aligned} &\leq 2 \sum_{j=0}^{j_0} 2^{(p-1)j} 2^{\frac{1}{2}jp} 2^{(-j_0+1)(1-\alpha)p} (t-s)^{\alpha p} + 2 \sum_{j=j_0+1}^n 2^{(p-1)j} 2^{-\frac{1}{2}jp-p} \\ &\leq 2^{1+(-j_0+1)(1-\alpha)p} \frac{2^{(\frac{3}{2}p-1)(j_0+1)}}{2^{\frac{3}{2}p-1}-1} (t-s)^{\alpha p} + 2^{1-p} \frac{2^{-(j_0+1)(1-\frac{p}{2})}}{1-2^{-(1-\frac{p}{2})}} \\ &\stackrel{(*)}{\leq} C_p (t-s)^{\alpha p}. \end{aligned}$$

In (*) we used the assumption that $\alpha = \frac{1}{p} - \frac{1}{2}$ to evaluate the left expression and $2^{-(j_0+1)} \leq (t-s)$ and $(1-\frac{p}{2}) = \alpha p$ to estimate the right expression. This concludes the proof of (9.42).

Now suppose, for a contradiction, that every function $f \in C^\alpha([0, 1]; \ell^p)$ belongs to $\gamma(0, 1; \ell^p)$. Then the closed graph theorem produces a constant $C \geq 0$ such that

$$\|\mathbb{I}f\|_{\gamma(0,1;\ell^p)} \leq C \|f\|_{C^\alpha([0,1];X)}.$$

Now (9.41) and (9.42) would imply that $K_p n^{1/p} \leq CC_p$ for all $n \geq 1$, which is absurd. \square

Close inspection of the proof reveals that the argument actually shows that if X is a Banach space such that $C^\alpha([0, 1]; X)$ embeds into $\gamma(0, 1; X)$ for $\alpha = \frac{1}{p} - \frac{1}{2}$, then X cannot contain the spaces ℓ_N^p uniformly. Therefore, by the Maurey-Pisier theorem X has type $p + \varepsilon$ for some $\varepsilon > 0$ (see the Notes of Chapter 7; the case $p = 1$ corresponds to Theorem 7.3.8). For $p = 1$, this observation combines with Theorem 9.7.3 to the following result:

Corollary 9.7.6. *For a Banach space X the following assertions are equivalent:*

- (1) $C^{1/2}([0, 1]; X) \hookrightarrow \gamma(0, 1; X)$ continuously;
- (2) X has non-trivial type.

9.7.c Embeddings involving holomorphic functions

In this subsection we work over the complex scalars. We are concerned with the relation between the radonifying norm and Bochner norms in spaces of holomorphic X -valued functions defined on suitable domains in the complex plane. Two domains are of principal interest: the horizontal strip of height $\alpha > 0$,

$$\mathbb{S}_\alpha := \{z \in \mathbb{C} : |\operatorname{Im}(z)| < \alpha\}$$

and the sector of angle $0 < \omega < \pi$,

$$\Sigma_\omega := \{z \in \mathbb{C} \setminus \{0\} : |\arg(z)| < \omega\}.$$

The following convention will be in force: If X_1 and X_2 are normed spaces, continuously embedded in a Hausdorff topological vector space \mathcal{X} , the notation $\|x\|_{X_1} \lesssim \|x\|_{X_2}$ will express that $x \in X_2$ implies $x \in X_1$ and the stated estimate holds with a constant independent of x and the spaces X_1 and X_2 .

The main result of this section is the following embedding result for holomorphic functions with values in a Banach space X with type p and cotype q . We recall the notation $\tau_{q,X}^\gamma$ and $c_{q,X}^\gamma$ for the Gaussian type p and Gaussian cotype q constants of X .

Theorem 9.7.7. *Let X be a Banach space with type $p \in [1, 2]$ and cotype $q \in [2, \infty]$. Let $0 \leq a < b < c\alpha$. Then we have the following estimates:*

(1) *For all holomorphic functions $f : \mathbb{S}_\alpha \rightarrow X$,*

$$\begin{aligned} & (c_{q,X}^\gamma)^{-1} \sum_{j \in \{-1, 1\}} \|f(t + ija)\|_{L^q(\mathbb{R}, dt; X)} \\ & \lesssim \sum_{j \in \{-1, 1\}} \|f(t + ijb)\|_{\gamma(\mathbb{R}, dt; X)} \\ & \lesssim \tau_{p,X}^\gamma \sum_{j \in \{-1, 1\}} \|f(t + ijc)\|_{L^p(\mathbb{R}, dt; X)}. \end{aligned}$$

(2) *For all holomorphic functions $f : \Sigma_\alpha \rightarrow X$ with $\alpha < \pi$,*

$$\begin{aligned} & (c_{q,X}^\gamma)^{-1} \sum_{j \in \{-1, 1\}} \|f(e^{ija}t)\|_{L^q(\mathbb{R}_+, \frac{dt}{t}; X)} \\ & \lesssim \sum_{j \in \{-1, 1\}} \|f(e^{ijb}t)\|_{\gamma(\mathbb{R}_+, \frac{dt}{t}; X)} \\ & \lesssim \tau_{p,X}^\gamma \sum_{j \in \{-1, 1\}} \|f(e^{ijc}t)\|_{L^p(\mathbb{R}_+, \frac{dt}{t}; X)}. \end{aligned}$$

The implied constants are independent of f and X .

The type p and cotype q assumptions are also necessary for the respective embedding to hold true; this is discussed in the Notes. After having developed some tools to handle radonifying norms of holomorphic functions, the proof Theorem 9.7.7 is given at the end of this subsection.

The spaces $\gamma^k(D; X)$

Let $D \subseteq \mathbb{R}^d$ be an open set and let $k \in \mathbb{N}$. For functions $f \in C^k(D; X)$ whose mixed partial derivatives up to order k belong to $\gamma(D; X)$ we define the norm

$$\|f\|_{\gamma^k(D; X)} := \sum_{|\alpha| \leq k} \|f^{(\alpha)}\|_{\gamma(D; X)},$$

and define the Banach space $\gamma^k(D; X)$ as the completion with respect to this norm of the space of functions used in its definition.

Identifying an open subset of \mathbb{C} with a subset of \mathbb{R}^2 , as a consequence of the Cauchy–Riemann equations we have the following simple result for holomorphic functions:

Proposition 9.7.8. *Let $D \subseteq \mathbb{C}$ be open and let $k \in \mathbb{N}$. A holomorphic function $f : D \rightarrow X$ belongs to $\gamma^k(D; X)$ if and only if its complex derivatives $f^{(j)}$, $j = 0, \dots, k$, belong to $\gamma(D; X)$.*

It is possible to relate the norm of a holomorphic function $f \in \gamma^k(D; X)$ to its classical Sobolev norm:

Proposition 9.7.9. *Let $D \subseteq \mathbb{C}$ be open and let $f : D \rightarrow X$ be a holomorphic function. Let D_1, D_2, D_3 be bounded open subsets of D such that $\overline{D_1} \subseteq D_2$ and $\overline{D_2} \subseteq D_3$. Then $f \in \gamma(D_2; X)$, and for all $p \in [1, \infty]$ and all integers $k, \ell \geq 0$ the following estimates hold:*

$$C_1^{-1} \|f\|_{W^{\ell,p}(D_1; X)} \leq \|f\|_{\gamma^k(D_2; X)} \leq C_2 \|f\|_{W^{\ell,p}(D_3; X)},$$

with constants C_1 and C_2 depending on k, ℓ, p , and the domains, but independent of f and X .

Proof. We begin with the proof of the right-hand estimate, for which it suffices to take $\ell = 0$ and $p = 1$. We can cover D_2 by finitely many balls contained in D_3 . By an argument involving a partition of unity, dilations, and translations, we may assume that $D_2 = \{z \in \mathbb{C} : |z| < 1\}$ and $D_3 = \{z \in \mathbb{C} : |z| < 1 + 2\varepsilon\}$ for some $\varepsilon > 0$.

By Cauchy's formula, for all $t \in [1 + \varepsilon, 1 + 2\varepsilon]$ we have

$$\begin{aligned} \frac{1}{n!} \|f^{(n)}(0)\| &= \frac{1}{2\pi} \left\| \oint_{\{|z|=t\}} \frac{f(z)}{z^{n+1}} dz \right\| \\ &\leq \frac{1}{2\pi} \frac{1}{(1 + \varepsilon)^{n+1}} \oint_{\{|z|=t\}} \|f(z)\| |dz|. \end{aligned}$$

Integrating over $t \in [1 + \varepsilon, 1 + 2\varepsilon]$, we find

$$\frac{1}{n!} \|f^{(n)}(0)\| \lesssim_\varepsilon \frac{1}{(1 + \varepsilon)^{n+1}} \|f\|_{L^1(D_3; X)}. \tag{9.44}$$

Writing $f(z) = \sum_{n=0}^\infty \frac{1}{n!} f^{(n)}(0) z^n$, by the triangle inequality and (9.44) we find

$$\begin{aligned} \|f^{(k)}\|_{\gamma(D_2; X)} &\leq \sum_{n=k}^\infty \frac{1}{(n-k)!} \|f^{(n)}(0)\| \|z^{n-k}\|_{L^2(D_2)} \\ &\lesssim_\varepsilon \|f\|_{L^1(D_3; X)} \sum_{n=k}^\infty \frac{n!}{(n-k)!} \frac{\pi^{1/2}}{(1 + \varepsilon)^{n+1}} =: C_{\varepsilon, k} \|f\|_{L^1(D_3; X)}. \end{aligned}$$

Turning to the left-hand side estimate, again it suffices to consider $D_1 = \{z \in \mathbb{C} : |z| < 1\}$ and $D_2 = \{z \in \mathbb{C} : |z| < 1 + 2\varepsilon\}$ for some $\varepsilon > 0$. Using Cauchy's formula again, the Cauchy-Schwarz inequality, and the inequality $\|\langle f, x^* \rangle\|_{L^2(D_2)} \leq \|f\|_{\gamma(D_2; X)} \|x^*\|$ (see (9.7)), for all $x^* \in X^*$ we find

$$\begin{aligned} \varepsilon |\langle f^{(k)}(0), x^* \rangle| &\leq \frac{k!}{2\pi} \int_{1+\varepsilon}^{1+2\varepsilon} \oint_{\{|z|=t\}} \frac{|\langle f(z), x^* \rangle|}{|z|^{k+1}} |dz| dt \\ &\lesssim_\varepsilon \frac{k!}{\varepsilon^k} \| \langle f, x^* \rangle \|_{L^2(D_2)} \leq C_{k,\varepsilon} \|f\|_{\gamma(D_2;X)} \|x^*\|. \end{aligned}$$

The result now follows by taking the supremum over all $\|x^*\| \leq 1$. □

Holomorphic functions on a strip

Consider the strip $\mathbb{S}_\alpha = \{z \in \mathbb{C} : |\text{Im}(z)| < \alpha\}$.

Proposition 9.7.10. *Fix a real number $\alpha > 0$ and let $f : \mathbb{S}_\alpha \rightarrow X$ be a holomorphic function. Then, for all $0 \leq a < b < \alpha$:*

- (1) $\sum_{\varepsilon \in \{-1,1\}} \sup_{s \in [0,1]} \left(\|f(\cdot + s + i\varepsilon a)\|_{\gamma(\mathbb{Z};X)} + \|f'(\cdot + s + i\varepsilon a)\|_{\gamma(\mathbb{Z};X)} \right) \lesssim \|f\|_{\gamma(\mathbb{S}_b;X)}$;
- (2) *if f is bounded, then* $\|f\|_{\gamma(\mathbb{S}_b;X)} \lesssim \sum_{\varepsilon \in \{-1,1\}} \|f(\cdot + i\varepsilon b)\|_{\gamma(\mathbb{R};X)}$;
- (3) $\sum_{\varepsilon \in \{-1,1\}} \|f(\cdot + i\varepsilon b)\|_{\gamma(\mathbb{R};X)} \leq \sum_{\varepsilon \in \{-1,1\}} \left(\|f(\cdot + i\varepsilon b)\|_{\gamma(\mathbb{Z};X)} + \int_0^1 \|f'(\cdot + s + i\varepsilon b)\|_{\gamma(\mathbb{Z};X)} ds \right)$,

where the finiteness of any of the expressions implies the finiteness of the previous expression in the chain of estimates. In each of the estimates, the implied constant depends on $b - a$ only.

Proof. (1): Let us first assume that $f \in \gamma(\mathbb{S}_b; X)$. Fix a radius $0 < r < \min\{\frac{1}{2}, b - a\}$ and a number $s \in [0, 1]$, and consider the disjoint balls $B_n := \{z \in \mathbb{C} : |z - n - s - ia| < r\}$, $n \in \mathbb{Z}$. The functions $\phi_n := |B_n|^{-1/2} \mathbf{1}_{B_n}$, $n \in \mathbb{Z}$, form an orthonormal system in $L^2(\mathbb{S}_b)$. By the mean value property (or Cauchy's formula),

$$f(n + s + ia) = \frac{1}{|B_n|} \int_{B_n} f(z) dA(z) = \frac{1}{r\pi^{1/2}} \mathbb{I}_f \phi_n,$$

where A is the area (2-dimensional Lebesgue) measure in the complex plane. It follows that for every $s \in [0, 1]$,

$$r\pi^{1/2} \|f(\cdot + s + ia)\|_{\gamma(\mathbb{Z};X)} = \left\| \sum_{n \in \mathbb{Z}} \gamma_n \mathbb{I}_f \phi_n \right\|_{L^2(\Omega;X)} \leq \|f\|_{\gamma(\mathbb{S}_b;X)}.$$

The same estimate holds for the γ -norm of $f(\cdot + s - ia)$.

To estimate the γ -norm of $f'(\cdot + s + ia)$ we use a similar argument. Fix again a radius $0 < r < \min\{\frac{1}{2}, b - a\}$. Consider the disjoint annuli $A_n := \{z \in \mathbb{C} : \frac{1}{2}r < |z - n - s - ia| < r\}$, $n \in \mathbb{Z}$. With

$$c^2 := \left\| z \mapsto \frac{\mathbf{1}_{A_n}}{z - (n + s + ia)} \right\|_{L^2(\mathbb{S}_b)}^2 = \int_0^{2\pi} \int_{r/2}^r |te^{i\theta}|^{-2} t \, dt \, d\theta = 2\pi \log(2),$$

the functions $z \mapsto \psi_n(z) := c^{-1}(z - (n + s + ia))^{-1} \mathbf{1}_{A_n}$, $n \in \mathbb{Z}$, form an orthonormal system in $L^2(\mathbb{S}_b)$. Using Cauchy's formula we find

$$f'(n + s + ia) = \frac{1}{|A_n|} \int_{A_n} \frac{f(z)}{z - (n + s + ia)} \, dA(z) = M \mathbb{I}_f \psi_n,$$

where $M := \frac{c}{|A_n|}$ depends only on r . It follows that for every $s \in [0, 1]$,

$$\frac{1}{M} \|f'(\cdot + s + ia)\|_{\gamma(\mathbb{Z}; X)} = \left\| \sum_{n \in \mathbb{Z}} \gamma_n \mathbb{I}_f \psi_n \right\|_{L^2(\Omega; X)} \leq \|f\|_{\gamma(\mathbb{S}_b; X)}.$$

The same estimate holds for the γ -norm of $f'(\cdot + s - ia)$. This completes the proof of (1).

(2): Assume now that f is bounded on \mathbb{S}_α and $f(\cdot + i\epsilon b) \in \gamma(\mathbb{R}; X)$ for $\epsilon \in \{-1, 1\}$. We will use the Poisson formula for the strip (see Lemma C.2.9, where it is formulated for the vertical unit strip),

$$g(x + iy) = [k_y^0 * g(\cdot + ib)](x) + [k_y^1 * g(\cdot - ib)](x), \quad x \in \mathbb{R}, \quad |y| < \alpha, \quad (9.45)$$

for bounded holomorphic functions $g : S_\alpha \rightarrow \mathbb{C}$ which are square-integrable on $\{z \in \mathbb{C} : \text{Im}(z) = \pm b\}$. The kernels $k_y^j : \mathbb{R} \rightarrow \mathbb{R}$ are positive and satisfy

$$\|k_y^0\|_{L^1(\mathbb{R})} + \|k_y^1\|_{L^1(\mathbb{R})} = \int_{\mathbb{R}} (k_y^0(t) + k_y^1(t)) \, dt = 1$$

for $-b < y < b$. As a consequence,

$$\begin{aligned} \|g(\cdot + iy)\|_{L^2(\mathbb{R})} &\leq \|k_y^0\|_{L^1(\mathbb{R})} \|g(\cdot + ib)\|_{L^2(\mathbb{R})} + \|k_y^1\|_{L^1(\mathbb{R})} \|g(\cdot - ib)\|_{L^2(\mathbb{R})} \\ &\leq \max_{\epsilon = \pm 1} \|g(\cdot + \epsilon ib)\|_{L^2(\mathbb{R})} \leq \|g\|_{L^2(\mathbb{R} + i\{\pm b\})}, \end{aligned}$$

and, integrating over $y \in (-b, b)$,

$$\|g\|_{L^2(\mathbb{S}_b)} \leq \sqrt{2b} \|g\|_{L^2(\mathbb{R} + i\{\pm b\})}.$$

Thus the linear mapping $K : L^2(\mathbb{R} + i\{\pm b\}) \rightarrow L^2(\mathbb{S}_b)$ given by

$$Kg(x + iy) := k_y^0 * g(\cdot + ib)(x) + k_y^1 * g(\cdot - ib)(x)$$

is bounded with norm $\leq \sqrt{2b}$, and by result of Example 9.6.4 extends to a bounded operator $K : \gamma(L^2(\mathbb{R} + i\{\pm b\}); X) \rightarrow \gamma(L^2(\mathbb{S}_b); X)$ of norm $\leq \sqrt{2b}$; moreover (9.45) holds with g replaced by f . Hence

$$\|f\|_{\gamma(\mathbb{S}_b; X)} \leq \sqrt{2b} \|f\|_{\gamma(\mathbb{R} + i\{\pm b\}; X)}$$

$$\leq \sqrt{2b} \left(\|f(\cdot + ib)\|_{\gamma(\mathbb{R}; X)} + \|f(\cdot - ib)\|_{\gamma(\mathbb{R}; X)} \right),$$

and the required estimate (2) follows.

(3): We use the simple fact that for all $t \in \mathbb{R}$ we have

$$f(t \pm ib) = \sum_{n \in \mathbb{Z}} \mathbf{1}_{[n, n+1)}(\cdot) f(n \pm ib) + \int_0^1 \sum_{n \in \mathbb{Z}} \mathbf{1}_{[n+s, n+1)}(\cdot) f'(n + s \pm ib) \, ds.$$

Hence, taking γ -norms with respect to $t \in \mathbb{R}$ on both sides,

$$\begin{aligned} \|f(\cdot \pm ib)\|_{\gamma(\mathbb{R}; X)} &\leq \left\| \sum_{n \in \mathbb{Z}} \mathbf{1}_{[n, n+1)}(t) f(n \pm ib) \right\|_{\gamma(\mathbb{R}, dt; X)} \\ &\quad + \int_0^1 \left\| \sum_{n \in \mathbb{Z}} \mathbf{1}_{[n+s, n+1)}(t) f'(n + s \pm ib) \right\|_{\gamma(\mathbb{R}, dt; X)} \, ds \\ &= \|f(\cdot \pm ib)\|_{\gamma(\mathbb{Z}; X)} + \int_0^1 (1-s)^{1/2} \|f'(\cdot + s \pm ib)\|_{\gamma(\mathbb{Z}; X)} \, ds, \end{aligned}$$

where the last step uses that $\|\mathbf{1}_{[n+s, n+1)}\|_{L^2(\mathbb{R})} = (1-s)^{1/2}$ along with the fact that if the functions h_n , $n \in \mathbb{Z}$, are orthonormal in $L^2(\mathbb{R})$, then $\|\sum_{n \in \mathbb{Z}} h_n \otimes x_n\|_{\gamma(\mathbb{R}; X)} = \| (x_n)_{n \in \mathbb{Z}} \|_{\gamma(\mathbb{Z}; X)}$. This completes the proof. \square

Proposition 9.7.11. *Let $f : \mathbb{S}_\alpha \rightarrow X$ be holomorphic and let $0 \leq a < b < c < d < \alpha$. Let $Z = \gamma(\mathbb{R}; X)$ or $Z = L^p(\mathbb{R}; X)$ with $p \in [1, \infty]$. Then for every integer $k \geq 1$ the following chain of inequalities holds:*

$$\sup_{y \in [-a, a]} \|f(\cdot + iy)\|_Z \lesssim \int_{-b}^b \|f(\cdot + iy)\|_Z \, dy \tag{9.46}$$

$$\lesssim \sum_{j=0}^k \|f^{(j)}(\cdot + iy)\|_{\gamma((-b, b), dy; Z)} \tag{9.47}$$

$$\lesssim \sum_{j=0}^{k+1} \sup_{y \in [-b, b]} \|f^{(j)}(\cdot + iy)\|_Z \tag{9.48}$$

$$\lesssim \sup_{y \in [-c, c]} \|f(\cdot + iy)\|_Z \tag{9.49}$$

$$\lesssim \sum_{\epsilon \in \{-1, 1\}} \|f(\cdot + \epsilon id)\|_Z, \tag{9.50}$$

where the finiteness of any of the expressions implies the finiteness of the previous expression in the chain of estimates. In all estimates the implied constants depend on a, b, c , and d , and the second and the fourth also on k , but are independent of f and X .

As a consequence of this result, all the norms in Proposition 9.7.10 are connected to the above expressions.

Proof. We prove (9.46) by using a Poisson transformation argument. As in the proof of Proposition 9.7.10 one sees that for all $\theta \in [b, a]$ and all $(x, y) \in \mathbb{R} \times [-a, a]$ we can write

$$f(x + iy) = [k_y^0 * f(\cdot + i\theta)](x) + [k_y^1 * f(\cdot - i\theta)](x),$$

and hence

$$\|f(\cdot + iy)\|_Z \leq \|f(\cdot + i\theta)\|_Z + \|f(\cdot - i\theta)\|_Z.$$

Now an integration over $\theta \in [b, a]$ gives (9.46). The inequality (9.50) can be proved in the same way, this time taking $\theta = d$ and $s \in [-c, c]$.

The inequalities (9.47) and (9.48) are immediate from Propositions 9.7.1 and 9.7.2, respectively.

It remains to prove the inequality (9.49). By assumption,

$$C := \sup_{y \in [-c, c]} \|f(\cdot + iy)\|_Z$$

is finite. Define the function $F : \mathbb{S}_c \rightarrow Z$ by

$$F(x + iy)(t) := f(t + x + iy), \quad t \in \mathbb{R}, (x, y) \in \mathbb{S}_c.$$

(In the case $Z = \gamma(\mathbb{R}; X)$, Proposition 9.7.9 guarantees that F indeed takes its values in Z .) We claim that F is holomorphic. By Proposition B.3.1 it suffices to show that F is bounded and $z \mapsto \langle F(z), g \rangle$ is holomorphic for all $g \in G$, where G is some subspace of Z^* separating the points of Z . For each $x + iy \in \mathbb{S}_c$, by translation invariance we have

$$\|F(x + iy)\|_Z = \|f(\cdot + x + iy)\|_Z = \|f(\cdot + iy)\|_Z \leq C.$$

Thus F is bounded. The subspace

$$G = \text{span}\{\mathbf{1}_I \otimes x^* : I \subseteq \mathbb{R} \text{ a bounded interval, } x^* \in X^*\}$$

separates the points of Z , and the functions

$$x + iy \mapsto \langle F(x + iy), \mathbf{1}_I \otimes x^* \rangle = \int_I \langle f(x + iy + t), x^* \rangle dt$$

are holomorphic. This establishes the claim.

We can now apply Proposition 9.7.9 and conclude that $F \in W^{k+1, \infty}(\mathbb{S}_b; Z)$ and $\|F\|_{W^{k+1, \infty}(\mathbb{S}_b; Z)} \lesssim \|F\|_{L^\infty(\mathbb{S}_c; Z)}$. Consequently, for all $y \in (-b, b)$,

$$\sum_{j=0}^{k+1} \|f^{(j)}(\cdot + iy)\|_Z = \sum_{j=0}^{k+1} \|F^{(j)}(iy)\|_Z \leq \|F\|_{W^{k+1, \infty}(\mathbb{S}_b; Z)} \lesssim \|F\|_{L^\infty(\mathbb{S}_c; Z)} \leq C.$$

Taking the supremum over $y \in [-b, b]$ gives

$$\sup_{y \in [-b, b]} \sum_{j=0}^{k+1} \|f^{(j)}(\cdot + iy)\|_Z \lesssim \sup_{y \in [-c, c]} \|f(\cdot + iy)\|_Z.$$

At the expense of another constant $k+1$, we may interchange the supremum and the sum on the left-hand side to obtain the estimate of (9.49). \square

We are now ready for the proof of Theorem 9.7.7.

Proof of Theorem 9.7.7. (1): We start with the proof of the first estimate. Fix $t \in [0, 1]$ and first assume that $q < \infty$. By Proposition 9.7.10,

$$\begin{aligned} \sum_{\epsilon \in \{-1, 1\}} \left(\sum_{n \in \mathbb{Z}} \|f(t + i\epsilon b)\|^q \right)^{1/q} &\leq c_{q, X}^\gamma \sum_{\epsilon \in \{-1, 1\}} \|f(\cdot + t + i\epsilon b)\|_{\gamma(\mathbb{Z}; X)} \\ &\leq c_{q, X}^\gamma \sum_{\epsilon \in \{-1, 1\}} \|f(\cdot + \epsilon ic)\|_{\gamma(\mathbb{R}; X)}. \end{aligned}$$

Taking q th powers and integrating over $t \in [0, 1]$, this gives the result. If $q = \infty$, the ℓ^q -sum on the left-hand side must be replaced by a supremum over $n \in \mathbb{Z}$.

Turning to the second estimate in (1), fix an arbitrary $c' \in (b, c)$. By the type p assumption,

$$\|n \mapsto f(n)\|_{\gamma(\mathbb{Z}; X)} \leq \tau_{p, X}^\gamma \left(\sum_{n \in \mathbb{Z}} \|f(n)\|^p \right)^{1/p}.$$

Therefore, by Proposition 9.7.10, for every $r \in [0, 1]$ we have

$$\begin{aligned} &\sum_{\epsilon \in \{-1, 1\}} \|f(\cdot + \epsilon ib)\|_{\gamma(\mathbb{R}; X)} \\ &= \sum_{\epsilon \in \{-1, 1\}} \|f(\cdot + r + \epsilon ib)\|_{\gamma(\mathbb{R}; X)} \\ &\lesssim \sum_{\epsilon \in \{-1, 1\}} \|f(\cdot + r + \epsilon ib)\|_{\gamma(\mathbb{Z}; X)} + \\ &\quad + \sum_{\epsilon \in \{-1, 1\}} \int_0^1 \|f'(\cdot + t + r + \epsilon ib)\|_{\gamma(\mathbb{Z}; X)} dt \\ &\leq \tau_{p, X}^\gamma \sum_{\epsilon \in \{-1, 1\}} \left(\sum_{n \in \mathbb{Z}} \|f(n + r + \epsilon ic')\|^p \right)^{1/p} + \\ &\quad + \tau_{p, X}^\gamma \sum_{\epsilon \in \{-1, 1\}} \int_0^1 \left(\sum_{n \in \mathbb{Z}} \|f'(n + t + r + \epsilon ic')\|^p \right)^{1/p} dt. \end{aligned}$$

Taking p th powers and integrating over all $r \in [0, 1]$ gives

$$\begin{aligned} & \sum_{\epsilon \in \{-1, 1\}} \|f(\cdot + \epsilon ib)\|_{\gamma(\mathbb{R}; X)} \\ & \lesssim \tau_{p, X}^\gamma \sum_{\epsilon \in \{-1, 1\}} \left(\|f(\cdot + \epsilon ic')\|_{L^p(\mathbb{R}; X)} + \|f'(\cdot + \epsilon ic')\|_{L^p(\mathbb{R}; X)} \right) \\ & \lesssim \tau_{p, X}^\gamma \sum_{\epsilon \in \{-1, 1\}} \|f(\cdot + \epsilon ic)\|_{L^p(\mathbb{R}; X)}, \end{aligned}$$

where the last estimate follows by application of (the last two estimates) of Proposition 9.7.11 with $Z = L^p(\mathbb{R}; X)$. This completes the proof of the second estimate in (1).

(2): The corresponding result for the sector follows from the result for the strip since $z \mapsto e^z$ maps the strip \mathbb{S}_b bi-holomorphically onto the sector Σ_b . Note that for the substitution $s = e^t$ one has $dt = \frac{ds}{s}$ which gives the additional division by t in (2) in both cases. \square

Remark 9.7.12. By Proposition 9.7.10 and its analogue for the L^p -norm, under the assumptions of Theorem 9.7.7 the following variation of the estimate in part (1) holds:

$$c\|f\|_{L^p(\mathbb{S}_c; X)} \leq \|f\|_{\gamma(\mathbb{S}_a; X)} \leq C\|f\|_{L^p(\mathbb{S}_b; X)}.$$

Similarly, the estimate in part (2) can be replaced by

$$c\|f\|_{L^q(\Sigma_c; X)} \leq \|f\|_{\gamma(\Sigma_a; X)} \leq C\|f\|_{L^p(\Sigma_b; X)}.$$

9.7.d Hilbert sequences

We have introduced γ -radonifying operators in terms of their action on finite orthonormal systems and obtained characterisations in terms of summability properties on orthonormal bases. Often one needs to estimate Gaussian sums $\sum_{n \geq 1} \gamma_n Th_n$ when the system $(h_n)_{n \geq 1}$ is not necessarily orthonormal but satisfies certain weaker conditions. In this section we develop some techniques to handle such situations and show their usefulness in two situations: we will use them to derive an estimate for continuous dual square functions (Proposition 9.7.19) and an R -boundedness result for Laplace transforms (Proposition 9.7.21) which is a variant of Example 9.6.17 valid without restrictions on the Banach space.

Definition 9.7.13. Let H be a Hilbert space with a maximal orthonormal system $(h_j)_{j \in I}$. A family $f = (f_j)_{j \in J}$ in H indexed by a subset $J \subseteq I$ is called a Hilbert system if there exists a constant $C \geq 0$ such that for any choice of finitely many scalars a_1, \dots, a_N and distinct indices $j_1, \dots, j_N \in J$,

$$\left\| \sum_{n=1}^N a_n f_{j_n} \right\|_H \leq C \left(\sum_{n=1}^N |a_n|^2 \right)^{1/2}.$$

The least admissible constant in this inequality be denoted by C_f and will be called the Hilbert constant of $f = (f_j)_{j \in J}$.

The reason for assuming that J is a subset of I is to avoid the possibility that J has a greater cardinality than I ; this already causes problems in the case I and J are finite. We will not always repeat this assumption; whenever we speak of a Hilbert system in a Hilbert space H , it will be implicitly understood that the cardinality of its index set does not exceed that of a maximal orthonormal system H . In most applications, $I = J$ is either the set of all integers or the set of positive integers, and in both cases such a Hilbert system will be called a *Hilbert sequence*.

Proposition 9.7.14. *Let $f = (f_j)_{j \in J}$ be a Hilbert system in H with Hilbert constant C_f .*

(1) *If $T \in \gamma_\infty(H, X)$, then*

$$\sup \left\| \sum_{n=1}^N \gamma_n T f_{j_n} \right\|_{L^2(\Omega; X)} \leq C_f \|T\|_{\gamma_\infty(H, X)},$$

where the supremum is taken over all finite choices of distinct indices $j_1, \dots, j_N \in J$.

(2) *If $T \in \gamma(H, X)$, then $\sum_{j \in J} \gamma_j T f_j$ is summable in $L^2(\Omega; X)$ and*

$$\left\| \sum_{j \in J} \gamma_j T f_j \right\|_{L^2(\Omega; X)} \leq C_f \|T\|_{\gamma(H, X)}.$$

For the definition of summability we refer to Definition 4.1.2; for countable index sets it is equivalent to unconditional convergence. In general, if $\sum_{j \in J} y_j$ is summable in a Banach space Y , then $y_j = 0$ for all but countably many $j \in J$.

Proof. Let $(h_i)_{i \in I}$ be a maximal orthonormal system in H .

(1): If j_1, \dots, j_N are distinct elements of J and $(h_i)_{i \in I}$ is a maximal orthonormal system with $J \subseteq I$, we may define a linear operator $S : H \rightarrow H$ by putting

$$S h_{j_n} := f_{j_n}$$

for $n \in \{1, \dots, N\}$ and $S h_j := 0$ for the remaining indices $j \in I \setminus \{j_1, \dots, j_N\}$. For $h \in H$ of the form $\sum_{n=1}^N a_n h_{j_n}$ we have

$$\|S h\|_H^2 = \left\| \sum_{n=1}^N a_n f_{j_n} \right\|_H^2 \leq C_f^2 \sum_{n=1}^N |a_n|^2 = C_f^2 \|h\|_H^2,$$

and the set of all such h is dense in H . It follows that S is bounded and $\|S\| \leq C_f$. The ideal property (Theorem 9.1.10) now gives

$$\mathbb{E} \left\| \sum_{n=1}^N \gamma_n T f_{j_n} \right\|^2 = \mathbb{E} \left\| \sum_{n=1}^N \gamma_n T S h_{j_n} \right\|^2 \leq \|TS\|_{\gamma_\infty(H, X)}^2 \leq C_f^2 \|T\|_{\gamma_\infty(H, X)}^2.$$

(2): We now define a linear operator $S : H \rightarrow H$ by $Sh_j := f_j$ for $j \in J$ and $Sh_j := 0$ for $j \in I \setminus J$. As before one sees that S is bounded and $\|S\| \leq C_f$.

The right ideal property implies $TS \in \gamma(H, X)$. By Theorem 9.1.19 $\sum_{j \in J} \gamma_j T f_j = \sum_{j \in J} \gamma_j T S h_j$ is summable in $L^2(\Omega; X)$ and

$$\mathbb{E} \left\| \sum_{j \in J} \gamma_j T f_j \right\|^2 = \mathbb{E} \left\| \sum_{j \in I} \gamma_j T S h_j \right\|^2 = \|TS\|_{\gamma(H, X)}^2 \leq C_f^2 \|T\|_{\gamma(H, X)}^2.$$

□

Examples of Hilbert sequences

A sequence is a Hilbert sequence if it is *almost orthogonal*:

Proposition 9.7.15. *Let $(f_n)_{n \in \mathbb{Z}}$ be a sequence in H . If there exists a function $F : \mathbb{Z} \rightarrow \mathbb{R}_+$ such that for all $n, m \in \mathbb{Z}$ we have*

$$|(f_n | f_m)| \leq F(n - m) \quad \text{with} \quad \sum_{j \in \mathbb{Z}} |F(j)| < \infty,$$

then $(f_n)_{n \in \mathbb{Z}}$ is a Hilbert sequence with constant at most $(\sum_{j \in \mathbb{Z}} |F(j)|)^{1/2}$.

Proof. Let $a = (a_n)_{n \in \mathbb{Z}}$ be a finitely non-zero sequence of scalars. Then

$$\left\| \sum_{n \in \mathbb{Z}} a_n f_n \right\|^2 = \sum_{m, n} a_n \overline{a_m} (f_n | f_m) \leq \sum_{m, n} |a_n| |a_m| F(n - m) \leq \|a\|_{\ell^2} \|a * F\|_{\ell^2}$$

where the last estimate follows from the Cauchy–Schwarz inequality; here $a * F$ denotes the convolution product for the additive group \mathbb{Z} with the counting measure. By Young’s inequality, $\|a * F\|_{\ell^2} \leq \|a\|_{\ell^2} \|F\|_{\ell^1}$ and therefore $\|\sum_{n \in \mathbb{Z}} a_n f_n\|^2 \leq \|F\|_{\ell^1} \|a\|_{\ell^2}^2$. □

The following example contains a simple application of Proposition 9.7.15 and will be used in Proposition 9.7.19.

Example 9.7.16. Fix real numbers $q > 0$ and $s \in \mathbb{R}$. For $n \in \mathbb{Z}$ let

$$f_{n,s}(t) := \frac{q}{\cosh(q(t - s + n))}, \quad t \in \mathbb{R}.$$

We will show that the sequence $(f_n)_{n \in \mathbb{Z}}$ is a Hilbert sequence in $L^2(\mathbb{R})$ with Hilbert constant at most $(10q + 16)^{1/2}$.

By a substitution, for all $n, m \in \mathbb{Z}$ we have

$$(f_n | f_m) = \int_{\mathbb{R}} \frac{q}{\cosh(t) \cosh(t + (n - m)q)} dt := F(n - m).$$

Then $F(0) = 2q$, $F(-j) = F(j)$, and for $j \geq 1$ we use the inequality $\cosh(x) \geq \frac{1}{2} \max\{e^x, e^{-x}\}$ to estimate the integral on each of the intervals $(-\infty, -jq]$, $(-jq, 0]$, $[0, \infty)$ separately:

$$\begin{aligned} \int_0^{\infty} \frac{1}{\cosh(t) \cosh(t + jq)} dt &\leq 4 \int_{[0, \infty)} e^{-2t - jq} dt = 2e^{-jq}, \\ \int_{-jq}^0 \frac{1}{\cosh(t) \cosh(t + jq)} dt &\leq 4 \int_{(-jq, 0]} e^t e^{-t - jq} dt = 4jq e^{-jq}, \\ \int_{-\infty}^{-jq} \frac{1}{\cosh(t) \cosh(t + jq)} dt &\leq 4 \int_{(-\infty, -jq]} e^{2t + jq} dt = 2e^{-jq}. \end{aligned}$$

Multiplying by q and adding up, for $j \geq 1$ this gives the bound $F(j) \leq 4q(1 + jq)e^{-jq}$. Accordingly,

$$\sum_{j \in \mathbb{Z}} F(j) \leq 2q + 8q \sum_{j \geq 1} (1 + jq)e^{-jq} = 2q + \frac{8q^2}{(e^q - 1)^2} + \frac{8q(q + 1)}{e^q - 1} \leq 10q + 16.$$

Now the result follows from Proposition 9.7.15.

A different class of examples is obtained as follows.

Proposition 9.7.17. *Let $\phi \in L^2(\mathbb{R})$ and define the sequence $(f_n)_{n \in \mathbb{Z}}$ in $L^2(\mathbb{R})$ by $f_n(t) = e^{2\pi i n t} \phi(t)$. Define $F : [0, 1] \rightarrow [0, \infty]$ as*

$$F(t) := \sum_{k \in \mathbb{Z}} |\phi(t + k)|^2.$$

Then $(f_n)_{n \in \mathbb{Z}}$ is a Hilbert sequence in $L^2(\mathbb{R})$ with Hilbert constant C if and only if $F(t) \leq C^2$ for almost every $t \in [0, 1]$.

Proof. Let $e_n(t) = e^{2\pi i n t}$ for $n \in \mathbb{Z}$. For a finitely non-zero sequence of scalars $(a_n)_{n \in \mathbb{Z}}$, we have

$$\begin{aligned} \left\| \sum_{n \in \mathbb{Z}} a_n f_n \right\|_{L^2(\mathbb{R})}^2 &= \sum_{k \in \mathbb{Z}} \int_k^{k+1} \left| \sum_{n \in I} a_n e_n(t) \phi(t) \right|^2 dt \\ &= \sum_{k \in \mathbb{Z}} \int_0^1 \left| \sum_{n \in \mathbb{Z}} a_n e_n(t) \phi(t + k) \right|^2 dt \\ &= \int_0^1 \left| \sum_{n \in \mathbb{Z}} a_n e_n(t) \right|^2 F(t) dt. \end{aligned}$$

If $F \leq C^2$ almost everywhere, the above identity gives

$$\left\| \sum_{n \in \mathbb{Z}} a_n f_n \right\|^2 \leq C^2 \left\| \sum_{n \in \mathbb{Z}} a_n e_n \right\|_{L^2(\mathbb{T})}^2 = C^2 \sum_{n \in \mathbb{Z}} |a_n|^2.$$

and $(f_n)_{n \in \mathbb{Z}}$ is a Hilbert sequence with constant C . Conversely, if $(f_n)_{n \in \mathbb{Z}}$ is a Hilbert sequence with constant C , the above identity shows that for all trigonometric polynomials $p = \sum_{n \in \mathbb{Z}} a_n e_n$ we have

$$\int_0^1 |p(t)|^2 F(t) dt \leq C^2 \sum_{n \in \mathbb{Z}} |a_n|^2 = C^2 \|p\|_{L^2(\mathbb{T})}^2.$$

This gives $F(t) \leq C^2$ for almost every $t \in [0, 1]$. □

Example 9.7.18. For any $a > 0$ and $\rho \in [0, 1)$ the functions

$$f_n(t) = e^{-at+2\pi i(n+\rho)t}, \quad n \in \mathbb{Z},$$

define a Hilbert sequence in $L^2(\mathbb{R}_+)$. Indeed, identifying f_n with functions in $L^2(\mathbb{R})$ and using the preceding notation, for all $t \in [0, 1]$ we have

$$F(t) = \sum_{k \in \mathbb{Z}} |\phi(t+k)|^2 = \sum_{k \geq 0} e^{-2a(t+k)} = \frac{e^{2a(1-t)}}{e^{2a} - 1}.$$

Now Proposition 9.7.17 implies that (f_n) , as a sequence in $L^2(\mathbb{R})$, is a Hilbert sequence with constant $C_f = 1/\sqrt{1 - e^{-2a}}$. But then of course (f_n) is also a Hilbert sequence in $L^2(\mathbb{R}_+)$, with the same constant.

Application to dual square functions

As a first application of Hilbert sequences we present two results providing estimates of continuous (dual) square functions in terms of related discrete square functions. Both will be needed in Chapter 10 (in the proofs of Propositions 10.4.15 and 10.4.15).

Let $\mathbb{S}_\alpha := \{z \in \mathbb{C} : |\operatorname{Im}(z)| < \alpha\}$ denote the horizontal strip of height α .

Proposition 9.7.19. *Let $g : \mathbb{S}_\alpha \rightarrow X^*$ be holomorphic. If*

$$\sup_{|\beta| < \alpha} \sup_{t \in [0, 1]} \sup_{N \geq 0} \left\| \sum_{|n| \leq N} \varepsilon_n g(n + t + i\beta) \right\|_{L^2(\Omega; X^*)} < \infty,$$

where $(\varepsilon_n)_{n \in \mathbb{Z}}$ is a Rademacher sequence, then g defines an element of $\gamma(\mathbb{R}; X)^*$ and

$$\|g\|_{\gamma(\mathbb{R}; X)^*} \leq C_\alpha \sup_{|\beta| < \alpha} \sup_{t \in [0, 1]} \sup_{N \geq 0} \left\| \sum_{|n| \leq N} \varepsilon_n g(\cdot + t + i\beta) \right\|_{L^2(\Omega; X^*)},$$

where $C_\alpha \approx \sqrt{1 + \frac{1}{\alpha}}$.

Proof. By taking $N = 0$, the assumption on g implies that it is bounded on \mathbb{S}_α . For $0 < \beta < \alpha$, the Poisson formula for the vertical unit strip (Lemma C.2.9), applied after a re-scaling to the horizontal strip \mathbb{S}_α , gives the following representation for the values of g on the real line:

$$g(t) = \sum_{\epsilon \in \{-1,1\}} k * g(\cdot + i\epsilon\beta)(t), \quad t \in \mathbb{R},$$

where $k(t) = 1/(4\beta \cosh(\frac{\pi t}{2\beta}))$. Therefore, for any step function $f : \mathbb{R} \rightarrow X$, by Fubini's theorem and the evenness of k we have

$$\begin{aligned} \int_{\mathbb{R}} \langle f(t), g(t) \rangle dt &= \sum_{\epsilon \in \{-1,1\}} \int_{\mathbb{R}} \langle k * f(t), g(t + i\epsilon\beta) \rangle dt \\ &= \sum_{\epsilon \in \{-1,1\}} \int_0^1 \sum_{n \in \mathbb{Z}} \langle k * f(t+n), g(t+n + i\epsilon\beta) \rangle dt \\ &= \sum_{\epsilon \in \{-1,1\}} \mathbb{E} \int_0^1 \left\langle \sum_{n \in \mathbb{Z}} \bar{\epsilon}_n k * f(t+n), \sum_{n \in \mathbb{Z}} \epsilon_n g(t+n + i\epsilon\beta) \right\rangle dt. \end{aligned}$$

Hence

$$\begin{aligned} \left| \int_{\mathbb{R}} \langle f(t), g(t) \rangle dt \right| &\leq \sum_{\epsilon \in \{-1,1\}} \sup_{t \in [0,1]} \left\| \sum_{n \in \mathbb{Z}} \bar{\epsilon}_n k * f(t+n) \right\|_{L^2(\Omega; X)} \\ &\quad \times \sup_{t \in [0,1]} \sup_{N \geq 0} \left\| \sum_{|n| \leq N} \epsilon_n g(t+n + i\epsilon\beta) \right\|_{L^2(\Omega; X^*)}. \end{aligned}$$

Estimating the Rademacher series by a Gaussian series using Corollary 6.1.17, we have

$$\begin{aligned} \left\| \sum_{n \in \mathbb{Z}} \epsilon_n k * f(t+n) \right\|_{L^2(\Omega; X)} &\leq \frac{1}{\mathbb{E}|\gamma|} \left\| \sum_{n \in \mathbb{Z}} \gamma_n k * f(t+n) \right\|_{L^2(\Omega; X)} \\ &= \frac{1}{\mathbb{E}|\gamma|} \left\| \sum_{n \in \mathbb{Z}} \gamma_n \mathbb{I}_f k_{n,t} \right\|_{L^2(\Omega; X)}, \end{aligned}$$

where $k_{n,t}(s) = k(t+n-s)$, $s \in \mathbb{R}$. Writing $k(s) = \frac{1}{2\pi} q / \cosh(qs)$ with $q = \pi/(2\beta)$, by the result of Example 9.7.16 the sequence $(k_{n,t})_{n \in \mathbb{Z}}$ is a Hilbert sequence with constant $c_\beta = \frac{1}{2\pi} \sqrt{10\pi/(2\beta) + 16}$. Therefore by Proposition 9.7.14,

$$\left\| \sum_{n \in \mathbb{Z}} \gamma_n \mathbb{I}_f k_{n,t} \right\|_{L^2(\Omega; X)} \leq c_\beta \|f\|_{\gamma(\mathbb{R}; X)}.$$

Combining the estimate, using that $\mathbb{E}|\gamma| = \sqrt{2/\pi}$, and finally letting $\beta \uparrow \alpha$, this gives the result, with constant $C_\alpha = \sqrt{\frac{5}{8\alpha} + \frac{2}{\pi}}$. \square

Using rather different techniques, an analogous result for square functions can be proved provided one replaces the Rademacher sequence by a Gaussian sequence.

Proposition 9.7.20. *Let $f : \mathbb{S}_\alpha \rightarrow X$ be holomorphic. If*

$$\sup_{|\beta| < \alpha} \sup_{t \in [0,1]} \|f(\cdot + t + i\beta)\|_{\gamma(\mathbb{Z}; X)} < \infty,$$

then $f \in \gamma(\mathbb{R}; X)$ and

$$\|f\|_{\gamma(\mathbb{R}; X)} \leq C_\alpha \sup_{|\beta| < \alpha, t \in [0,1]} \|f(\cdot + t + i\beta)\|_{\gamma(\mathbb{Z}; X)},$$

where $C_\alpha \approx \sqrt{\alpha} + \frac{1}{\alpha}$.

Proof. Consider the isometric isomorphism $J : L^2(\mathbb{R}) \rightarrow L^2((0,1) \times \mathbb{Z})$ defined by $Jf(t, n) := f(t + n)$. By Theorem 9.6.1

$$\|f\|_{\gamma(\mathbb{R}; X)} \leq \|(t, n) \mapsto f(t + n)\|_{\gamma((0,1) \times \mathbb{Z}; X)}.$$

Fix $\beta \in [\alpha/2, \alpha)$ and put $R_\beta := \{z \in \mathbb{C} : 0 \leq -\frac{1}{2} < \Re(z) < \frac{3}{2}, |\Im(z)| < \beta\}$. For all $t \in [0, 1)$ and $n \in \mathbb{Z}$, Cauchy's theorem gives

$$f(t + n) = \frac{1}{2\pi i} \int_{\partial R_\beta} \frac{f(z + n)}{z - t} dz$$

The function

$$z \mapsto \left[(t, n) \mapsto \frac{f(z + n)}{z - t} \right]$$

is Bochner integrable along ∂R_β as a function with values in $\gamma(L^2((0,1) \times \mathbb{Z}); X)$ and

$$\begin{aligned} & \|(t, n) \mapsto f(t + n)\|_{\gamma((0,1) \times \mathbb{Z}; X)} \\ & \leq \frac{1}{2\pi} \int_{\partial R_\beta} \left\| (t, n) \mapsto \frac{f(z + n)}{z - t} \right\|_{\gamma((0,1) \times \mathbb{Z}; X)} |dz| \\ & = \frac{1}{2\pi} \int_{\partial R_\beta} \left\| \frac{1}{z - \cdot} \right\|_{L^2(0,1)} \|f(z + \cdot)\|_{\gamma(\mathbb{Z}; X)} |dz| \\ & \leq \sup_{|\beta| < \alpha} \sup_{t \in [0,1]} \|f(\cdot + t + i\beta)\|_{\gamma(\mathbb{Z}; X)} \times \frac{1}{2\pi} \int_{\partial R_\beta} \left\| \frac{1}{z - \cdot} \right\|_{L^2(0,1)} |dz|, \end{aligned}$$

where the middle inequality follows from the result of Example 9.4.12. This completes the proof, except for the quantitative estimate for the constant. For this we estimate the integral on the right-hand side by using that if $t \in [0, 1)$, then $|z - t| \geq \beta \geq \frac{\alpha}{2}$ if $z = x \pm i\beta$ with $-\frac{1}{2} \leq x \leq \frac{3}{2}$ and $|z - t| \geq 1$ if $z = \frac{1}{2} \pm 1 + iy$ with $-\beta \leq y \leq \beta$. Thus each of the two horizontal parts contributes

at most $\sqrt{2} \cdot \frac{2}{\alpha}$, and each of the vertical parts at most $\sqrt{2\beta} \cdot 1 \leq \sqrt{2\alpha}$. This leads to the explicit bound

$$C_\alpha = \frac{\sqrt{2}}{\pi} \left(\frac{2}{\alpha} + \sqrt{\alpha} \right).$$

□

Application to Laplace transforms

As a second application we will prove a version of Example 9.6.17 in general Banach spaces.

Proposition 9.7.21. *Suppose that $\phi : \mathbb{R}_+ \rightarrow \mathcal{L}(X, Y)$ is strongly measurable and has the property that $\phi x \in \gamma_\infty(\mathbb{R}_+; Y)$ with $\|\phi x\|_{\gamma_\infty(\mathbb{R}_+; Y)} \leq K \|x\|$ for all $x \in X$. Define, for $\lambda \in \mathbb{C}_+ = \{\lambda \in \mathbb{C} : \Re \lambda > 0\}$, the operators $\widehat{\phi}(\lambda) \in \mathcal{L}(X, Y)$ by*

$$\widehat{\phi}(\lambda)x := \int_0^\infty e^{-\lambda t} \phi(t)x \, dt.$$

Then for every $\delta > 0$, the family

$$\{\widehat{\phi}(\lambda) : \Re(\lambda) \geq \delta\}$$

is R -bounded, and its R -bound is at most $\sqrt{2\pi}e^{2\pi}K/\sqrt{1 - e^{-\delta}}$.

Proof. Fix real numbers $\delta > 0$, $a \in [\delta/2, 3\delta/2]$, and $\rho \in [0, 1)$. By Example 9.7.18 and a suitable substitution

$$f_n(t) = e^{-at - 2\pi i(n+\rho)t}, \quad n \in \mathbb{Z},$$

defines a Hilbert sequence in $L^2(\mathbb{R}_+)$ with constant $C_f^2 = \frac{1}{1 - e^{-2a}} \leq \frac{1}{1 - e^{-\delta}}$. Therefore, by Corollary 6.1.17 and Proposition 9.7.14, for all $x \in X$ and for $N \geq 0$ we obtain

$$\begin{aligned} \mathbb{E} \left\| \sum_{|n| \leq N} \varepsilon_n \widehat{\phi}(a + 2\pi i(n + \rho))x \right\|^2 &\leq \frac{1}{(\mathbb{E}|\gamma|)^2} \mathbb{E} \left\| \sum_{|n| \leq N} \gamma_n \widehat{\phi}(a + 2\pi(n + \rho))x \right\|^2 \\ &\leq \frac{C_f^2}{(\mathbb{E}|\gamma|)^2} \|\phi x\|_{\gamma_\infty(\mathbb{R}_+; Y)}^2 \\ &\leq \frac{K^2}{(\mathbb{E}|\gamma|)^2(1 - e^{-\delta})} \|x\|^2. \end{aligned}$$

By Proposition 8.4.6(1) setting $V_\delta = \{z \in \mathbb{C} : \delta/2 \leq \Re(z) \leq 3\delta/2\}$, we have

$$\sup_{z \in \partial V_\delta} \mathcal{R}(\{\widehat{\phi}(z + 2\pi in) : n \in \mathbb{Z}\}) \leq \frac{K}{\mathbb{E}|\gamma| \sqrt{1 - e^{-\delta}}}.$$

The function $\widehat{\phi}$ is bounded and holomorphic on $\{z \in \mathbb{C} : \Re(z) \geq \delta\}$. Indeed, it is clear that $\widehat{\phi}$ is bounded and that $z \mapsto \langle \widehat{\phi}(z)x, x^* \rangle$ is holomorphic for all $x^* \in X^*$. The proof of Proposition B.3.1 shows that $z \mapsto \widehat{\phi}(z) \in \mathcal{L}(X, Y)$ is continuous in the uniform operator topology, and therefore Corollary B.3.3 implies the asserted holomorphy.

Now we apply Corollary 8.5.9. After translating and rotating our strip, we infer from this corollary (and after letting the width of the strip tend to zero) that

$$\mathcal{R}(\{\widehat{\phi}(z) : \Re(z) \geq \delta\}) \leq \mathcal{R}(\{\widehat{\phi}(z) : \Re(z) = \delta\}) \leq \frac{2e^{2\pi K}}{\mathbb{E}|\gamma|\sqrt{1 - e^{-\delta}}}.$$

□

9.8 Notes

The quote in the beginning of the chapter is taken from Stein [1982]. This reference contains an excellent overview of the development of square functions in harmonic analysis.

Section 9.1

The heuristics behind our approach to this topic are largely due to Kalton and Weis [2016]; many of the actual results treated in the other sections are also from this paper. Despite its relatively recent publication year, a preprint had circulated in the community for more than a decade and provided the infrastructure and the inspiration for much of the work on this topic over the current century, including large parts of the present chapter.

The theory of γ -radonifying operators can be traced back to the pioneering works of Gel'fand [1955], Segal [1956], Gross [1962, 1967], Kallianpur [1971]. The class of γ -summing operators was introduced by Linde and Pietsch [1974] and further studied by Figiel and Tomczak-Jaegermann [1979]. Linde and Pietsch [1974] also contains Proposition 9.1.3 and Example 9.1.21. Some related results from these papers are discussed further below in these Notes (see page 351). The first systematic study of γ -radonifying operators is Neidhardt [1978].

The ideal property (Theorem 9.1.10) can be traced back to Gross [1962, Theorem 5]. Another proof of the ideal property for $H_1 = H_2 =: H$ and $\mathbb{K} = \mathbb{C}$ can be given by using that

- (i) Every Hilbert space operator T of norm less than 1 is a convex combination of finitely many unitaries;
- (ii) If $R : H \rightarrow X$ is γ -radonifying and U is unitary on H , then $RU : H \rightarrow X$ is γ -radonifying (with the same norm).

An elementary proof of (i) can be found in [Gardner \[1984\]](#) (see also [Blackadar \[2006\]](#)). Assertion (ii) is an immediate consequence of the fact that unitaries map orthonormal systems to orthonormal systems. If one only considers finite rank operators (or finite Gaussian sums) as in [Proposition 6.1.23](#) it suffices to show that every matrix of norm ≤ 1 can be written as a convex combination of unitary matrices. In this form the proof was presented in [Diestel, Jarchow, and Tonge \[1995\]](#), Theorem 12.15].

A variant of this proof can be based on writing a contraction T as a sum of two self-adjoint contractions, for example $T = \frac{1}{2}(T+T^*) + \frac{1}{2}(T-T^*)$, and then writing a self-adjoint contraction S as a convex combination of two unitaries, for example $S = \frac{1}{2}(S + i\sqrt{I - S^*S}) + \frac{1}{2}(S - i\sqrt{I - S^*S})$. The simplicity of this argument comes at a price: it produces an additional constant 2.

[Theorem 9.1.14](#) combines results from [Van Neerven, Veraar, and Weis \[2007a\]](#) and [Cox and Van Neerven \[2010\]](#).

The characterisation of γ -radonifying operators in terms of their action on an orthonormal bases ([Theorem 9.1.17](#)) is frequently taken as the definition of γ -radonifying operators and goes back to the early days of the subject; an obvious disadvantage of this approach is that it limits the scope of the theory to separable Hilbert spaces. This unsatisfactory state of affairs is fixed by [Theorem 9.1.19](#), which is taken from [Van Neerven \[2010\]](#).

As is evident from its proof, [Theorem 9.1.20](#) on the equality of $\gamma(H, X) = \gamma_\infty(H, X)$ for Banach spaces X not containing a copy of c_0 is hardly more than a restatement of the Kwapien–Hoffmann–Jørgensen theorem ([Theorem 6.4.10](#)) in the Gaussian context. In its present formulation the result is taken from [Kalton and Weis \[2016\]](#). [Example 9.1.21](#) is due to [Linde and Pietsch \[1974\]](#).

[Theorem 9.1.24](#) is essentially due to [Pisier \[1989\]](#); its present formulation was stated by [Kalton and Weis \[2016\]](#), where the other results of [Section 9.1.f](#) can also be found.

Complex interpolation of $\gamma(H_0, X_0)$ and $\gamma(H_1, X_1)$ is considered in [Suárez and Weis \[2006, 2009\]](#). In [Theorem 9.1.25](#) we have only presented the special case where $H_0 = H_1$.

The γ -radonification of the indefinite integral $J : L^2(0, 1) \rightarrow C[0, 1]$ asserted in [Corollary 9.1.27](#) is equivalent to the existence of Brownian motion and even provides a natural formula for Brownian motion in terms of a Gaussian series. When stated in this form, [Corollary 9.1.27](#) is a classical result which goes back to [Wiener \[1923\]](#). The proof of [Corollary 9.1.27](#) via the Haar system is due to [Ciesielski \[1991\]](#). It is a substantial simplification of Wiener's original arguments, which used the trigonometric system instead. [Revuz and Yor \[1999\]](#) offers a comprehensive study of Brownian motion and its many applications.

It follows from [Corollary 9.1.27](#) that Brownian motions have a version with paths in $C^\alpha[0, 1]$ for all $\alpha \in [0, 1/2)$. It is well-known that almost surely the paths do not belong to $C^{1/2}[0, 1]$. It was shown in [Ciesielski \[1991\]](#) (see also [Ciesielski \[1993\]](#)) that the trajectories of a Brownian motion do belong to the

Besov space $B_{p,\infty}^{1/2}(0,1)$ almost surely, for any $p \in [1, \infty)$. Since the indefinite integral γ -radonifying as an operator from $L^2(0,1)$ to $C^\alpha(0,1)$ for $\alpha \in [0, \frac{1}{2})$, this result could suggest that the indefinite integral should be γ -radonifying as an operator from $L^2(0,1)$ to $B_{p,\infty}^{1/2}(0,1)$. Perhaps surprisingly, this is not the case. In fact, in [Roynette \[1993\]](#) it is shown that there exists a constant $C > 0$ with the property that the $B_{p,\infty}^{1/2}(0,1)$ -norm of almost all trajectories of the Brownian motion B are greater than C . Now, if $J : L^2(0,1) \rightarrow B_{p,\infty}^{1/2}(0,1)$ were γ -radonifying, then the induced random variable $B : \Omega \rightarrow B_{p,\infty}^{1/2}(0,1)$ would be strongly measurable and Gaussian (in the sense that its composition with any functional $x^* \in X^*$ is Gaussian distributed). But then the general theory of Gaussian random variables precludes the existence of the aforementioned constant C (see, e.g., [Ledoux and Talagrand \[1991\]](#), Section 3.1). [Roynette \[1993\]](#) also showed that almost surely the trajectories of B do not belong to $B_{p,q}^{1/2}(0,1)$ for any $q \in [1, \infty)$. The above results have been extended to the setting of Brownian motions with values in Banach spaces in [Hytönen and Veraar \[2008\]](#) with a different approach.

Early history of γ -radonifying operators

The pioneering works of [Gel'fand \[1955\]](#), [Segal \[1956\]](#), [Gross \[1962, 1967\]](#), [Kallianpur \[1971\]](#), [Baxendale \[1976\]](#) considered the so-called *radonification problem* which asks for conditions for a cylindrical distribution on a Banach space X to be representable as an X -valued random variable.

A *cylindrical distribution* on a Banach space X is a bounded linear operator $W : X^* \rightarrow L^2(\Omega)$, where (Ω, \mathbb{P}) is a probability space. It is said to be *Gaussian* if Wx^* is Gaussian distributed for all $x^* \in X^*$. The prime example arises in the context of Hilbert spaces: If H is a Hilbert space with maximal orthonormal system $(h_i)_{i \in I}$, and $(\gamma_i)_{i \in I}$ a family of independent standard Gaussian random variables with the same index set on a probability space (Ω, \mathbb{P}) , then for all $h \in H$, the family $(\gamma_i(h|h_i))_{i \in I}$ is summable in $L^2(\Omega)$ (in the sense defined in [Chapter 4](#)) and

$$W_H h := \sum_{i \in I} \gamma_i(h|h_i), \quad h \in H, \quad (9.51)$$

defines a cylindrical Gaussian distribution W_H on H . The rather straightforward proof is left to the reader. In some respects, the cylindrical distribution W serves as a substitute for the Lebesgue measure in the infinite dimensional context. This idea will be further developed in the next volume in connection with the co-called Malliavin calculus.

A cylindrical distribution $W : X^* \rightarrow L^2(\Omega)$ is said to be *Radon* if there exists a random variable $\xi : \Omega \rightarrow X$ such that $Wx^* = \langle \xi, x^* \rangle$ for all $x^* \in X^*$. Here, as always, it is understood that random variables are strongly measurable; therefore, the distribution of the random variable ξ , if it exists, is a Radon probability measure on X . (A probability measure μ on a topological

Hausdorff space T is said to be *Radon* if for every $\varepsilon > 0$ there exists a compact subset K of T such that $\mu(\mathbb{C}K) < \varepsilon$. Also note that the random variable ξ , if it exists, is necessarily unique.

If T is a bounded linear operator from X into another real Banach space Y , then T maps every (Gaussian) cylindrical distribution W_H on X to a cylindrical (Gaussian) distribution $T(W)$ on Y given by

$$T(W)y^* := W(T^*y^*), \quad y^* \in Y^*.$$

The following theorem can be found in [Kuo \[1975\]](#):

Theorem 9.8.1. *A bounded operator $T : H \rightarrow X$ is γ -radonifying (i.e., belongs to $\gamma(H, X)$) if and only if the cylindrical distribution $T(W_H)$ on X is Radon.*

For Gaussian cylindrical distributions, [Gross \[1962, 1967\]](#) obtained a further necessary and sufficient condition for γ -radonification in terms of so-called measurable seminorms on H . These developments marked the birth of the theory of Gaussian distributions on Banach spaces. Comprehensive accounts of this theory can be found in [Vakhania, Tarieladze, and Chobanyan \[1987\]](#), [Bogachev \[1998\]](#).

Section 9.2

We follow the presentation of [Kalton and Weis \[2016\]](#). Theorem 9.2.14 is taken from this reference. Proposition 9.2.8 is due to [Rosiński and Suchanecki \[1980\]](#). Theorem 9.2.10 goes back to [Hoffmann-Jørgensen and Pisier \[1976\]](#) and [Rosiński and Suchanecki \[1980\]](#); in its present formulation it can be found in [Van Neerven and Weis \[2005b\]](#).

Section 9.3

The isomorphic identification $\gamma(H, L^p(\mu)) \approx L^p(\mu; H^*)$ of Proposition 9.3.2 goes back to the extension theorem of Marcinkiewicz, Paley, and Zygmund, presented here as Theorem 2.1.9. In its present formulation the result can be found in [Brzeźniak and Peszat \[1999\]](#) (under some additional assumptions) and [Brzeźniak and Van Neerven \[2003\]](#). A related result can be found in [Carmona and Chevet \[1979\]](#).

Corollary 9.3.3 and Example 9.3.4 go back to [Van Neerven, Veraar, and Weis \[2008\]](#). The special case for $p = 2$ (in the formulation that if (S, \mathcal{A}, μ) is a finite measure space, then every operator on $L^2(S)$ which can be factored through $L^\infty(S)$ is Hilbert–Schmidt) is folklore; we learnt the result through [Arendt \[2005/06\]](#). Example 9.3.4 is not optimal: the Sobolev embeddings of this example are in fact p -summing (which is stronger in view of Proposition 9.8.7 below).

Theorem 9.3.6 unifies various results in [Van Neerven, Veraar, and Weis \[2007a,b, 2008\]](#). Theorem 9.3.8 is due to [Van Neerven and Weis \[2005a\]](#).

Section 9.4

Theorems 9.4.1 goes back to Neidhardt [1978]. In its present form it is taken from Van Neerven [2010]. Theorem 9.4.2 is essentially due to Van Neerven and Weis [2005a]. Theorem 9.4.10 is due to Kalton and Weis [2016]. A detailed investigation of the connection of Theorem 9.4.10 with properties (α^\pm) (see Proposition 7.5.4) is carried out in Van Neerven and Weis [2008].

Section 9.5

Theorem 9.5.1 is due to Kalton and Weis [2016], where also a simple version of its converse, Proposition 9.5.6, can be found. It is an open problem whether the multiplier M always takes $\gamma(S; X)$ to $\gamma(S; X)$.

Section 9.6

The extension property of Theorem 9.6.1 is due to Kalton and Weis [2016]. Besides being an important theoretical tool, it is often useful when there is no extension from $L^2(S)$ to the Bochner space $L^2(S; X)$ for a given Banach space X .

The R -boundedness results for Banach spaces with Pisier's contraction property of Theorem 9.6.10 and Corollary 9.6.12 (and its converse Proposition 9.6.11) are due to Haak and Kunstmann [2006]. They applied these results to admissibility questions in control theory (see Haak [2004] and the referenced cited therein). Some of their results hold under different assumptions on the underlying Banach spaces. Theorem 9.6.13 is due to Kaiser and Weis [2008]; the dual version in Theorem 9.6.14 is due to Hytönen and Veraar [2009]. We do not know whether the assumptions on Y in Example 9.6.17 can be dropped or relaxed. A partial result in this direction is Proposition 9.7.21.

The characterisation of R -boundedness of translations on $\gamma(\mathbb{R}; X)$ of Proposition 9.6.18 seems to be new.

Section 9.7

Proposition 9.7.1 is due to Kalton and Weis [2016] and Proposition 9.7.2 is due to Veraar and Weis [2015].

Theorem 9.7.3 can be viewed as a special case of the main result of Kalton, Van Neerven, Veraar, and Weis [2008], which asserts that if either $D = \mathbb{R}^d$ or $D \subseteq \mathbb{R}^d$ is a non-empty bounded open domain, then a Banach space X has type $p \in [1, 2]$ if and only if the Besov space $B_{p,p}^{(\frac{1}{p}-\frac{1}{2})d}(D; X)$ embeds continuously into $\gamma(D; X)$. The converse embedding holds if and only if X has cotype p . The proof of these results are based on an extension argument to reduce the proof to the case $D = \mathbb{R}^d$ and Fourier analytic description of the norm of the Besov space based on the Littlewood-Paley decomposition. The

non-trivial fact that $B_{p,p}^s(D; X) = W^{s,p}(D; X)$ with equivalent norms will be proved in the next volume. The direct proof of Theorem 9.7.3 presented here for $D = I$, an open interval in \mathbb{R} , is a variation of the one given in Van Neerven, Veraar, and Weis [2007b].

Example 9.7.5 is due to Van Neerven, Veraar, and Weis [2007b], where the same example is actually used to prove that $C^{\frac{1}{p}-\frac{1}{2}}([0, 1]; X)$ embeds into $\gamma(0, 1; X)$ if and only if X has *stable type* p . For a discussion of stable type we refer the reader to Ledoux and Talagrand [1991] and Pisier [1986a]. For the present discussion the following facts are relevant:

- stable type 2 is equivalent to type 2;
- for any $p \in [1, 2)$, stable type p implies type $p + \varepsilon$ for some $\varepsilon > 0$.

Proposition 9.4.13 is due to Kalton, Van Neerven, Veraar, and Weis [2008].

The results of Section 9.7.c are taken from Veraar and Weis [2015]. There, the necessity of the type p and cotype q assumption for Theorem 9.7.7 was proved as well. Both can be deduced by applying the estimate in the strip case to

$$f(t) = \sum_{n=1}^N \phi_n(t)x_n, \text{ where } \phi_n(z) = \text{sinc}(2\pi z - c_n),$$

with $c_1, \dots, c_N \geq 0$ a suitable sequence of real numbers which grows exponentially and which makes the sequence $(\phi_n)_{n \geq 1}$ orthogonal on $L^2(-1, 1)$. In particular, the γ -norm of ϕ is simple to calculate. However, it is quite tedious to find good estimates for the L^p and L^q -norms of f .

The results on Hilbert sequences presented in Section 9.7.d are taken from Haak, Van Neerven, and Veraar [2007]. If one is interested in *sufficient* conditions for γ -radonification, the role of orthonormal systems may be replaced by Bessel sequences. This provides a flexible tool for checking γ -radonification. A family of vectors $(f_j)_{j \in \mathbb{Z}}$ in H is called a *Bessel sequence* if there exists a constant $C \geq 0$ such that for any finite distinct choice of $j_1, \dots, j_N \in \mathbb{Z}$ and $\alpha_1, \dots, \alpha_N \in \mathbb{K}$,

$$\left(\sum_{n=1}^N |\alpha_n|^2 \right)^{1/2} \leq C \left\| \sum_{n=1}^N \alpha_n f_{j_n} \right\|_H.$$

It is immediate from the definition that Bessel sequences have to be linearly independent.

Proposition 9.7.21 was first proved in Van Neerven and Weis [2006]. The proof using Hilbert sequences is from Haak, Van Neerven, and Veraar [2007], where similar methods are used to also show that the set $\{\sqrt{\lambda}\widehat{\phi}(\lambda) : \lambda \in \Sigma_{\frac{\pi}{2}-\varepsilon}\}$ is R -bounded for every $\varepsilon \in (0, \pi/2)$. Proposition 9.7.17 is due to Casazza, Christensen, and Kalton [2001]. The argument in Example 9.7.18 is taken from Haak, Van Neerven, and Veraar [2007, Example 2.5]. The following more general result is given in Jacob and Zwart [2001, Theorem 1, (3) \Leftrightarrow (5)]. A *Riesz sequence* is a sequence that is both a Hilbert sequence and a Bessel sequence.

Theorem 9.8.2. Let $(\lambda_n)_{n \geq 1}$ be a sequence in \mathbb{C}_+ which is properly spaced in the sense that

$$\inf_{m \neq n} \left| \frac{\lambda_m - \lambda_n}{\Re(\lambda_n)} \right| > 0.$$

Then the functions

$$f_n(t) := \sqrt{\Re(\lambda_n)} e^{-\lambda_n t}, \quad n \geq 1,$$

define a Riesz sequence, i.e., there are constants $0 < c \leq C < \infty$ such that

$$c^2 \sum_{n \geq 1} |\alpha_n|^2 \leq \left\| \sum_{n \geq 1} \alpha_n f_n \right\|^2 \leq C^2 \sum_{n \geq 1} |\alpha_n|^2$$

for all sequences $(\alpha_n)_{n \geq 1} \in \ell^2$.

More on this topic can be found in Young [2001].

Further results

More on γ -summing operators

Let H and X be a Hilbert space and a Banach space, respectively. As an application of the ideal property we give a characterisation of $\gamma_\infty(H, X)$ which does not involve the use of orthonormal systems.

Theorem 9.8.3. Let $p \in [1, \infty)$. For a bounded operator $T \in \mathcal{L}(H, X)$ the following are equivalent:

- (1) $T \in \gamma_\infty(H, X)$;
- (2) there exists a constant $C_p \geq 0$ such that for all finite sequences $(h_n)_{n=1}^N$ in H ,

$$\left\| \sum_{n=1}^N \gamma_n T h_n \right\|_{L^p(\Omega; X)} \leq C_p \sup_{\|h\| \leq 1} \left(\sum_{n=1}^N |(h_n|h)|^2 \right)^{1/2}.$$

In this situation, $\|T\|_{\gamma_\infty^p(H, X)}$ equals the least admissible constant in (2).

Proof. If (2) holds, then we obtain (1) by considering orthonormal h_1, \dots, h_N ; this also gives the inequality $\|T\|_{\gamma_\infty^p(H, X)} \leq C_0$, where C_0 is the least admissible constant in (2). Suppose now that (1) holds and fix vectors $h_1, \dots, h_N \in H$. Let u_1, \dots, u_N be the standard unit vectors of ℓ_N^2 and define $S : \ell_N^2 \rightarrow H$ by $Su_n = h_n$. Then

$$\begin{aligned} \|S\| &= \sup_{\|u\|_{\ell_N^2} \leq 1, \|h\| \leq 1} |(Su|h)| \\ &= \sup_{\substack{\|h\| \leq 1 \\ \|c\|_{\mathbb{R}^N} \leq 1}} \left| \sum_{n=1}^N c_n (h_n|h) \right| = \sup_{\|h\| \leq 1} \left(\sum_{n=1}^N |(h_n|h)|^2 \right)^{1/2}. \end{aligned}$$

Now (2), as well as the inequality $C_0 \leq \|T\|_{\gamma_\infty^p(H,X)}$, follows from the right ideal property:

$$\mathbb{E} \left\| \sum_{n=1}^N \gamma_n T h_n \right\|^p = \mathbb{E} \left\| \sum_{n=1}^N \gamma_n T S u_n \right\|^p \leq \|TS\|_{\gamma_\infty^p(\ell_N^2)}^p \leq \|T\|_{\gamma_\infty^p(H,X)}^p \|S\|^p.$$

□

This result suggests the following definition.

Definition 9.8.4. *Let X and Y be Banach spaces.*

- (i) *A bounded operator $T : X \rightarrow Y$ is said to be γ -summing if there exists a constant $C \geq 0$ such that for all finite sequences $(x_n)_{n=1}^N$ in X we have*

$$\left\| \sum_{n=1}^N \gamma_n T x_n \right\|_{L^2(\Omega; X)} \leq C \sup_{\|x^*\| \leq 1} \left(\sum_{n=1}^N |\langle x_n, x^* \rangle|^2 \right)^{1/2}. \tag{9.52}$$

- (ii) *A bounded operator $T : X \rightarrow Y$ is said to be γ -radonifying if there exists a constant $C \geq 0$ such that for all sequences $(x_n)_{n \geq 1}$ in X we have*

$$\left\| \sum_{n \geq 1} \gamma_n T x_n \right\|_{L^2(\Omega; X)} \leq C \sup_{\|x^*\| \leq 1} \left(\sum_{n \geq 1} |\langle x_n, x^* \rangle|^2 \right)^{1/2}. \tag{9.53}$$

In the second part of this definition it is part of the assumptions that the sum $\sum_{n \geq 1} \gamma_n T x_n$ converges in $L^2(\Omega; X)$ for all sequences $(x_n)_{n \geq 1}$ with the property that $\sum_{n \geq 1} |\langle x_n, x^* \rangle|^2$ is finite.

It is rather surprising that the Gaussian sequences in the above definition may be replaced by Rademacher sequences to obtain an equivalent definition:

Theorem 9.8.5. *Let X and Y be Banach spaces. A bounded operator $T : X \rightarrow Y$ is γ -summing (respectively, γ -radonifying) if and only if (9.52) (respectively, (9.53)) holds with the Gaussian sequences replaced by Rademacher sequences.*

A detailed proof can be found in [Diestel, Jarchow, and Tonge \[1995, Theorem 12.20\]](#). For the reader’s convenience we sketch the main steps in the real case; the complex case requires some obvious adjustments. We only need to show that the Rademacher definition implies its Gaussian counterpart, the converse being a consequence of the fact that we can always estimate Rademacher sums by Gaussian sums ([Corollary 6.1.17](#)).

Let S^{N-1} be the unit sphere in \mathbb{R}^N and let $O(N)$ denote the group of orthogonal matrices on \mathbb{R}^N . Each $a \in S^{N-1}$ defines a mapping $\varphi_a : O(N) \rightarrow S^{N-1}$ by $\varphi_a(v) := v(a)$. The first observation is that the image under φ_a of the Haar measure σ^N of $O(N)$ equals the normalised surface area measure λ^{N-1} on S^{N-1} :

$$\varphi_a(\sigma^N) = \lambda^{N-1}, \quad a \in S^{N-1}.$$

By change of variables, this is then used to show that if $U : \ell_N^2 \rightarrow X$ is a bounded operator, then

$$\mathbb{E} \left\| \sum_{n=1}^N \gamma_n U e_n \right\|^2 = \int_{O(N)} \mathbb{E} \left\| \sum_{n=1}^N \varepsilon_n U v e_n \right\|^2 d\sigma^N(v),$$

with $(e_n)_{n=1}^N$ the standard unit basis of ℓ_N^2 . Using self-explanatory terminology, now let $T : X \rightarrow Y$ be ε -summing. Fix an arbitrary sequence $(x_n)_{n=1}^N$ in X and consider the operator $Y : \ell_N^2 \rightarrow X$ defined by $U e_n := x_n$. Applying the above identity to TU and using that T is ε -summing we obtain

$$\begin{aligned} \mathbb{E} \left\| \sum_{n=1}^N \gamma_n T x_n \right\|^2 &= \int_{O(N)} \mathbb{E} \left\| \sum_{n=1}^N \varepsilon_n T U v e_n \right\|^2 d\sigma^N(v) \\ &\leq C^2 \sup_{v \in O(N)} \sup_{\|x^*\| \leq 1} \sum_{n=1}^N |\langle U v e_n, x^* \rangle|^2 \\ &\leq C^2 \sup_{v \in O(N)} \sup_{\|x^*\| \leq 1} \|v^* U^* x^*\|^2 \\ &\leq C^2 \|U\|^2 = C^2 \sum_{n \geq 1} |\langle x_n, x^* \rangle|^2. \end{aligned}$$

This proves that T is γ -summing. The proof of the corresponding assertion about radonification follows by a standard Cauchy sequence argument.

Let W be the cylindrical mapping defined in (9.51). The main result of [Linde and Pietsch \[1974\]](#) (who define γ -summing operators through (9.52)) asserts that a bounded operator $T : H \rightarrow X$ is γ -summing if and only if $T(W)$ is *weak*-Radon*, in the sense that there exists a weak*-measurable random variable ξ with values in X^{**} , whose distribution is a Radon measure on (X, weak^{**}) , such that $T(W)x^* = \langle x^*, \xi \rangle$ almost surely for all $x^* \in X^*$. This result is a natural companion to the fact, observed at the beginning of these Notes, that a bounded operator $T : H \rightarrow X$ is γ -radonifying if and only if $T(W)$ is Radon.

Next we will prove that the trace duality result of Proposition 9.1.22 extends to γ -summing operators. More precisely, for $T \in \gamma_\infty(H, X)$ and $S \in \gamma_\infty(H^*, X^*)$ we have

$$|\text{tr}(S^*T)| \leq \|S^*T\|_{\mathcal{C}^1(H)} \leq \|S\|_{\gamma_\infty(H^*, X^*)} \|T\|_{\gamma_\infty(H, X)}.$$

One can argue as before, but we have to assure that $R = S^*T$ is a compact operator. To prove this first note that as in the proof of Proposition 9.1.22 one sees that for all orthonormal systems $(f_n)_{n \geq 1}$ and $(g_n)_{n \geq 1}$ in H we have $\sum_{n \geq 1} |(Rf_i|g_i)| \leq \|S\|_{\gamma_\infty(H^*, X^*)} \|T\|_{\gamma_\infty(H, X)}$. It follows from [Diestel, Jarchow, and Tonge \[1995, Theorem 4.6\(a\)\]](#) that R is compact. Therefore, R has a singular value decomposition and the proof can be finished along the lines of Proposition 9.1.22.

Alternatively, for each finite $I \subseteq \mathbb{N}$, we let $T_I = \sum_{i \in I} h_i^* \otimes Th_i$. This forms a net in a natural way and $\langle T_I h, x^* \rangle \rightarrow \langle Th, x^* \rangle$ for all $h \in H$ and $x^* \in X^*$. Since each T_I has finite rank, S^*T_I is compact and hence the proof of Proposition 9.1.22 and the ideal property give that $\|S^*T_I\|_{\mathcal{C}^1(H)} \leq K$. Since $C^1(H) = \mathcal{K}(H)^*$, it follows that there exists a sub-net $(\phi(I))_I$ and $R \in \mathcal{C}^1(H)$ such that $S^*T_{\phi(I)} \rightarrow R$ weak*. Identification of the limit shows that $R = S^*T$ and by the properties of the weak*-topology we have $\|S^*R\|_{\mathcal{C}^1(H)} \leq \|S\|_{\gamma_\infty(H^*, X^*)} \|T\|_{\gamma_\infty(H, X)}$.

Relation to p-summing operators

Recall from Section 7.2.a that an operator is p -summing if there exists a constant $C \geq 0$ such that for all choices $x_1, \dots, x_N \in X$,

$$\left(\sum_{n=1}^N \|Tx_n\|^p \right)^{1/p} \leq C \sup_{\|x^*\| \leq 1} \left(\sum_{n=1}^N |\langle x_n, x^* \rangle|^p \right)^{1/p}, \tag{9.54}$$

and we write $\pi_p(T)$ for the least admissible constant C .

In the original definition of p -summing, the sequence spaces ℓ^p can be equivalently replaced by any sufficiently non-trivial $L^p(S)$ -space.

Lemma 9.8.6. *Let X, Y be Banach spaces, $T \in \mathcal{L}(X, Y)$, and (S, \mathcal{A}, μ) be a measure space. If T is p -summing, then*

$$\|Tf\|_{L^p(S; Y)} \leq C \sup_{\|x^*\| \leq 1} \|\langle f, x^* \rangle\|_{L^p(S)}, \quad f \in L^p(S; X) \tag{9.55}$$

with $C \leq \pi_p(T)$. Conversely, if (9.55) holds for some infinite-dimensional $L^p(S)$, then T is p -summing and $\pi_p(T) \leq C$.

Proof. Assume first that T is p -summing. Since both sides of (9.55) are continuous in $f \in L^p(S; X)$, it suffices to check the bound for every simple function $f = \sum_{n=1}^N z_n \mathbf{1}_{A_n}$ (disjoint A_n). But this reduces to (9.54) with $x_n = \mu(A_n)^{1/p} z_n$.

Conversely, suppose that (9.55) holds. The assumption that $\dim L^p(S) = \infty$ implies that we can choose disjoint sets A_1, \dots, A_N with $\mu(A_n) \in (0, \infty)$. To prove (9.54), it suffices to write (9.55) for $f = \sum_{n=1}^N \mathbf{1}_{A_n} \mu(A_n)^{-1/p} x_n$. \square

As a consequence we obtain that every p -summing operator is γ -summing:

Proposition 9.8.7. *If $T \in \pi^p(X, Y)$ for some $1 \leq p < \infty$, then $T \in \gamma_\infty(X, Y)$ and*

$$\|T\|_{\gamma_\infty(X, Y)} \leq \kappa_{p,2} \|T\|_{\pi^p(X, Y)}.$$

In particular, if $c_0 \not\subseteq Y$ and $X = H$ is a Hilbert space, then $\pi^p(H, Y) \hookrightarrow \gamma(H, Y)$ continuously by Theorems 9.1.20 and 9.8.3.

Proof. For a finite system $(x_n)_{n=1}^N$ in X , we have, applying Lemma 9.8.6 to the function $f = \sum_{n=1}^N \gamma_n x_n \in L^p(\Omega; X)$ in the first step,

$$\begin{aligned} \left\| \sum_{n=1}^N \gamma_n T x_n \right\|_{L^p(\Omega; Y)} &\leq \pi_p(T) \sup_{x^* \in B_{X^*}} \left\| \sum_{n=1}^N \gamma_n \langle x_n, x^* \rangle \right\|_{L^p(\Omega)} \\ &\leq \pi_p(T) \kappa_{p,2} \sup_{x^* \in B_{X^*}} \left\| \sum_{n=1}^N \gamma_n \langle x_n, x^* \rangle \right\|_{L^2(\Omega)} \\ &= \pi_p(T) \kappa_{p,2} \sup_{x^* \in B_{X^*}} \left(\sum_{n=1}^N |\langle x_n, x^* \rangle|^2 \right)^{1/2} \end{aligned}$$

□

This result is just a sample from a body of related results, none of which will be used in these volumes. Further results along this line are developed in Diestel, Jarchow, and Tonge [1995]. For example, it is shown that if Y has cotype 2, then for every $p \in [2, \infty)$ the space $\gamma_\infty(X, Y)$ coincides with the space $\pi^p(X, Y)$ of p -summing operators from X to Y . Furthermore, if X also has cotype 2, this is true for all $p \in [1, \infty)$.

In fact, γ -radonifying operators can be thought of as the Gaussian analogues of p -summing operators. For a systematic exposition of this point of view we refer the reader to the Maurey-Schwartz seminar notes published between 1972 and 1976, the monograph by Schwartz [1973], and the lecture notes by Badrikian and Chevet [1974]. More recent monographs touching on this subject include Bogachev [1998], Mushtari [1996], and Vakhania, Tarieladze, and Chobanyan [1987].

The Kwapien-Szymański theorem

If H is separable, then a bounded operator from H into another Hilbert space X is Hilbert-Schmidt if and only if for some (equivalently, every) orthonormal basis $(h_n)_{n \geq 1}$ of H we have

$$\sum_{n \geq 1} \|Th_n\|^2 < \infty. \tag{9.56}$$

This leads to the natural question whether, if $T : H \rightarrow X$ is γ -radonifying from a separable Hilbert space H into a Banach space X , it is true that (9.56) holds for some (or every) orthonormal basis $(h_n)_{n \geq 1}$ of H . For spaces X with cotype 2 the answer is trivially affirmative. The next example shows that, in general, (9.56) need not hold for every orthonormal basis:

Example 9.8.8. Let $T : \ell^2 \rightarrow \ell^p$ be the diagonal operator $(c_n)_{n \geq 1} \mapsto (a_n c_n)_{n \geq 1}$. Here we assume that $(a_n)_{n \geq 1}$ is bounded and $2 \leq p < \infty$, so that T is well defined as a bounded operator.

Denote by $(e_n)_{n \geq 1}$ the standard unit basis of ℓ^2 . From

$$\mathbb{E} \left\| \sum_{n=M}^N \gamma_n a_n e_n \right\|^p = \mathbb{E} \sum_{n=M}^N |\gamma_n|^p |a_n|^p = \mathbb{E} |\gamma|^p \sum_{n=M}^N |a_n|^p$$

we see that T is γ -radonifying if and only if $(a_n)_{n \geq 1}$ belongs to ℓ^p . In that case,

$$\sum_{n \geq 1} \|Te_n\|^2 = \sum_{n \geq 1} |a_n|^2,$$

and this sum diverges if we take $(a_n)_{n \geq 1}$ from $\ell^p \setminus \ell^2$.

This example is rather discouraging, and the following affirmative result due to Kwapien and Szymański [1980] may therefore come as a surprise.

Theorem 9.8.9 (Kwapien–Szymański). *Let H be a separable Hilbert space and X a Banach space. If $T \in \gamma(H, X)$, then there exists an orthonormal basis $(h_n)_{n \geq 1}$ of H such that*

$$\sum_{n \geq 1} \|Th_n\|^2 < \infty.$$

Proof. Fix any orthonormal basis $(h_n)_{n \geq 1}$ of H . By assumption, the sequence $\sum_{n \geq 1} \gamma_n Th_n$ converges in $L^2(\Omega; X)$, and therefore there exist indices $0 = N_1 < N_2 < \dots$ such that

$$\sum_{n \geq 1} \mathbb{E} \left\| \sum_{j=N_n+1}^{N_{n+1}} \gamma_j Th_j \right\|^2 < \infty.$$

To finish the proof we will show that there exists, for every $n \geq 1$, a unitary operator $U_n \in \mathcal{L}(H_n)$, where H_n is the span of the vectors $h_{N_n+1}, \dots, h_{N_{n+1}}$, such that

$$\sum_{j=N_n+1}^{N_{n+1}} \|TU_n h_j\|^2 \leq \mathbb{E} \left\| \sum_{j=N_n+1}^{N_{n+1}} \gamma_j Th_j \right\|^2. \tag{9.57}$$

The orthonormal basis $(h'_n)_{n \geq 1}$ defined by $h'_j = U_n h_j$ for $N_n + 1 \leq j \leq N_{n+1}$ then has the desired property.

Let ν_n denote the Haar measure on the compact group $U(H_n)$ of all unitary operators on H_n . Denoting by σ_n the surface measure on the unit sphere S_n of H_n and using that σ_n is the image measure of ν_n under the mapping $U \mapsto Uh_j$, for all $N_n + 1 \leq j \leq N_{n+1}$ we have

$$\int_{TU(H_n)} \|TU h_j\|^2 d\nu_n(U) = \int_{S_n} \|Th\|^2 d\sigma_n(h).$$

Summing over j and using that σ_n is also the image measure of $(N_{n+1} - N_n)^{-1} \|\cdot\|^2 d\gamma_n(\cdot)$ under the mapping $h \mapsto h/\|h\|$, we obtain

$$\begin{aligned} \sum_{j=N_n+1}^{N_{n+1}} \int_{TU(H_n)} \|Uh_j\|^2 d\nu_n(U) &= (N_{n+1} - N_n) \int_{S_n} \|Th\|^2 d\sigma_n(h) \\ &= (N_{n+1} - N_n) \int_{S_n} \left\| T \frac{h}{\|h\|} \right\|^2 \|h\|^2 d\sigma_n(h) \\ &= \int_{H_n} \|Th\|^2 d\gamma_n(h) = \mathbb{E} \left\| \sum_{j=N_n+1}^{N_{n+1}} \gamma_j Th_j \right\|^2. \end{aligned}$$

Since ν_n is a probability measure, there must exist a $U_n \in U(H_n)$ such that (9.57) holds. \square

Entropy numbers

Following Pietsch [1980, Chapter 12], the *entropy numbers* $e_n(T)$ of a bounded operator $T \in \mathcal{L}(X, F)$ are defined as the infimum of all $\varepsilon > 0$ such that there are $x_1, \dots, x_{2^{n-1}} \in T(B_X)$ such that

$$T(B_X) \subseteq \bigcup_{j=1}^{2^{n-1}} (x_j + \varepsilon B_F).$$

Here B_X and B_F denote the closed unit balls of X and F . Note that T is compact if and only if $\lim_{n \rightarrow \infty} e_n(T) = 0$. Thus the entropy numbers $e_n(T)$ measure the degree of compactness of an operator T .

The following result is due to Kühn [1982]. The two parts of the theorem can be viewed as an operator theoretical reformulation of classical results due to Dudley [1967] (part (1)) and Sudakov [1971] (part (2)).

Theorem 9.8.10. *For any bounded operator $T \in \mathcal{L}(H, X)$,*

- (1) *if $\sum_{n \geq 1} n^{-1/2} e_n(T^*) < \infty$, then $T \in \gamma(H, X)$;*
- (2) *if $T \in \gamma(H, X)$, then $\sup_{n \geq 1} n^{1/2} e_n(T^*) < \infty$.*

In fact we have the following quantitative version of part (2): there exists an absolute constant $C \geq 0$ such that for all Hilbert spaces H , Banach spaces X , and operators $T \in \gamma(H, X)$ we have

$$\sup_{n \geq 1} n^{1/2} e_n(T^*) \leq C \|T\|_{\gamma(H, X)}.$$

In combination with a result of Tomczak-Jaegermann [1987] to the effect that for any compact operator $T \in \mathcal{L}(\ell^2, X)$ we have

$$\frac{1}{32} e_n(T^*) \leq e_n(T) \leq 32 e_n(T^*),$$

and recalling that γ -radonifying operators are supported on a separable closed subspace by Proposition 9.1.7, this implies the inequality

$$\sup_{n \geq 1} n^{1/2} e_n(T) \leq C \|T\|_{\gamma(H, X)}$$

for some absolute constant C . See Cobos and Kühn [2001] and Kühn and Schonbek [2001], where these results are applied to obtain estimates for the entropy numbers of certain diagonal operators between Banach sequence spaces. Kühn [1982] also showed that Theorem 9.8.10 can be improved for Banach spaces with (co)type 2:

Theorem 9.8.11. *For any bounded operator $T \in \mathcal{L}(H, X)$,*

- (1) *if X has type 2 and $(\sum_{n \geq 1} (e_n(T^*))^2)^{1/2} < \infty$, then $T \in \gamma(H, X)$;*
- (2) *if X has cotype 2 and $T \in \gamma(H, X)$, then $(\sum_{n \geq 1} (e_n(T^*))^2)^{1/2} < \infty$.*

The H^∞ -functional calculus

Now that we have a variety of probabilistic and operator-theoretic tools at our disposal it is time to start using them. The present chapter is devoted to the study of sectorial operators (this class of operators includes, e.g., uniformly elliptic second order differential operators) and their holomorphic functional calculus formally defined by the Dunford integral

$$f(A) = \frac{1}{2\pi i} \int_{\partial\Sigma} f(z)(z - A)^{-1} dz.$$

Here f is a bounded holomorphic function on a sector Σ about the positive real line containing the spectrum of A , and on the complement of $\overline{\Sigma}$ the parabolic bound

$$\|(z - A)^{-1}\| \lesssim \frac{1}{|z|}$$

is assumed. Unless f has additional integrability properties near the origin and infinity, this Dunford integral is a singular integral and the operator $f(A)$ can be defined only as an unbounded operator. If $f(A)$ is bounded and satisfies

$$\|f(A)\| \lesssim \|f\|_\infty$$

for all bounded holomorphic function on Σ , then A is said to have a bounded H^∞ -calculus on Σ . For classical operators such as $A = -\Delta$ on $L^p(\mathbb{R}^d)$, the boundedness of the H^∞ -calculus can be proved using Fourier analysis methods such as the Fourier multiplier theorems of Volume I and classical square function estimates. With this model in mind we use the probabilistic and operator-theoretic techniques of earlier chapters of the present volume to develop the theory of H^∞ -calculus for general sectorial operators acting on a Banach. In particular we study their R -boundedness properties and characterisations in terms of the generalised square functions developed in the previous chapter. Both will play a crucial role in Volume III as a bridge connecting estimates from harmonic analysis, stochastic analysis, and operator theory. This

will be particularly useful in the theory of maximal regularity for solutions of evolution equations of parabolic type.

To give an impression of how the Banach space properties studied in earlier chapters enter the picture we mention the facts, proved in this chapter, that the Laplace operator on $L^p(\mathbb{R}^d; X)$, $1 < p < \infty$, has a bounded H^∞ -calculus if and only if X is a UMD space, and that in this situation the range of its H^∞ -calculus is γ -bounded if and only if X also has Pisier's contraction property.

Besides studying the H^∞ -calculus for its own sake, we provide three important classes of examples of operators admitting a bounded H^∞ -calculus:

- If A is the generator of a C_0 -semigroup of contractions on a Hilbert space, then A has a bounded H^∞ -calculus;
- If A is the generator of a C_0 -semigroup of positive contractions on an L^p -space, then A has a bounded H^∞ -calculus.
- If iA is the generator of a bounded C_0 -group on a UMD space, then A has a bounded H^∞ -calculus.

After a careful study of the H^∞ -calculus for sectorial operators, in the second part of the chapter we also consider bisectorial operators and, in particular, generators of bounded C_0 -groups. Their functional calculus properties are intimately connected to those of sectorial operators, a fact which we exploit to pass from third example in our list, which can be treated by means of transference techniques, to the second via dilation arguments. In the concluding section we combine the ℓ^p -boundedness techniques of Chapter 8 with interpolation theory and an ergodic theorem to give a substantial improvement of the second example in case the semigroup has a bounded analytic extension to a sector.

10.1 Sectorial operators

For $0 < \omega < \pi$ we denote by

$$\Sigma_\omega := \{z \in \mathbb{C} \setminus \{0\} : |\arg(z)| < \omega\}$$

the open sector of angle ω in the complex plane; the argument is taken in $(-\pi, \pi)$. For $z \in \varrho(A)$, the resolvent set of A , let $R(z, A) := (z - A)^{-1}$ denote the resolvent of A . Any operator with non-empty resolvent set is closed.

Definition 10.1.1 (Sectorial operators). *A linear operator $(A, D(A))$ is said to be sectorial if there exists $\omega \in (0, \pi)$ such that the spectrum $\sigma(A)$ is contained in $\overline{\Sigma_\omega}$ and*

$$M_{\omega, A} := \sup_{z \in \mathfrak{L}\overline{\Sigma_\omega}} \|zR(z, A)\| < \infty.$$

In this situation we say that A is ω -sectorial with constant $M_{\omega,A}$. The infimum of all $\omega \in (0, \pi)$ such that A is ω -sectorial is called the angle of sectoriality of A and is denoted by $\omega(A)$.

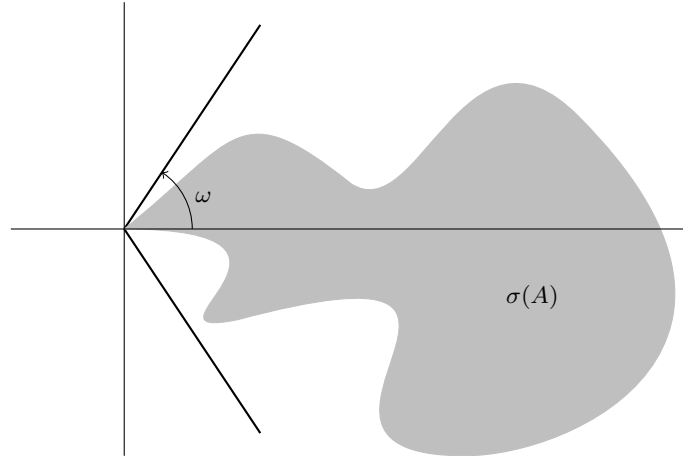

Fig. 10.1: The spectrum of a sectorial operator

The reader is cautioned that the definition of sectoriality varies in the literature. As we will see, various results admit a somewhat cleaner statement if the requirement that A have dense range is added to the definition, and this is indeed what some authors do. This has the further benefit that sectorial operators with dense range are automatically injective. What is more, imposing dense range is hardly a restriction, for the following reason. If the Banach space X is reflexive (and more generally, if the resolvent operators of A are weakly compact), then every sectorial operator A on X is densely defined and we have a direct sum decomposition

$$X = \mathbf{N}(A) \oplus \overline{\mathbf{R}(A)}. \quad (10.1)$$

Moreover, the part of A in $\overline{\mathbf{R}(A)}$ is sectorial, densely defined, has dense range, and is injective, while the part of A in $\mathbf{N}(A)$ equals the zero operator. Thus all useful information about A is contained in the part of A in $\overline{\mathbf{R}(A)}$. The reader is referred to Propositions 10.1.8 and 10.1.9 for the full statement of these results.

There are various reasons for insisting on the more general definition of a sectorial operator adopted here. Firstly, some natural sectorial operators fail to have dense range. These include the Laplace operator on $L^1(\mathbb{R}^d)$, the Neumann Laplacian on $L^p(D)$ with $D \subseteq \mathbb{R}^d$ bounded, and the Ornstein-Uhlenbeck operator on $L^p(\mathbb{R}^d, \gamma_d)$, with γ_d the standard Gaussian measure on

\mathbb{R}^d . Secondly, with our definition of sectoriality, the adjoint A^* of a densely defined sectorial operator is sectorial, but with an additional dense range condition this statement would no longer be true, as in general the range of A^* is weak*-dense only. Thirdly, and perhaps most importantly, in our approach it becomes transparent which results need additional assumptions and which do not. In general, the need of additional assumptions is reflected in limitations on range of applicability. For instance, in the treatment of the H^∞ -calculus associated with a sectorial operator A , as a rule of thumb statements about $f(A)x$ for functions in $f \in H^1(\Sigma)$ tend to be true for general elements x in X , whereas statements involving functions $f \in H^\infty(\Sigma)$ usually require the consideration of elements x in $D(A) \cap R(A)$ or its closure.

10.1.a Examples

Before turning to some basic properties of sectorial operators it is instructive to present some examples. With an eye towards the above discussion, in each of these examples we pay attention as to whether or not the operator has dense range and/or is injective. We will freely use the terminology and results of Appendix G on semigroups of operators.

The first two examples describe the relationship between sectorial operators and bounded (analytic) semigroups.

Example 10.1.2 (Sectorial operators and bounded semigroups). If a linear operator $-A$ generates a uniformly bounded C_0 -semigroup $(S(t))_{t \geq 0}$ on a Banach space X , then A is densely defined, closed, and ω -sectorial for all $\frac{1}{2}\pi < \omega < \pi$. In particular, $\omega(A) = \frac{1}{2}\pi$. Indeed, by Proposition G.4.1, the open left half-plane $\mathbb{C}_- = \{\Re \lambda < 0\}$ is contained in the resolvent set of A and we have the bound

$$\|R(\lambda, A)\| \leq \frac{M}{|\Re \lambda|}$$

for all $\lambda \in \mathbb{C}_-$. Moreover, if $|\arg(\lambda)| \geq \frac{1}{2}\pi + \nu$, with $\nu \in (0, \frac{1}{2}\pi)$, then

$$\|R(\lambda, A)\| \leq \frac{M}{|\Re \lambda|} \leq \frac{M}{\sin \nu} \frac{1}{|\lambda|}$$

and A is $\frac{1}{2}\pi + \nu$ -sectorial.

Example 10.1.3 (Sectorial operators and bounded analytic semigroups). Theorem G.5.2 may be formulated as stating that for a densely defined operator A on a Banach space X ,

$$A \text{ is sectorial of angle } 0 < \theta < \frac{1}{2}\pi \tag{10.2}$$

if and only if

$$-A \text{ generates a bounded analytic } C_0\text{-semigroup } (S(t))_{t \geq 0} \tag{10.3}$$

on Σ_η for some $0 < \theta < \frac{1}{2}\pi$.

Moreover,

$$\inf \{ \theta \in (0, \pi/2) : (10.2) \text{ holds} \} = \pi/2 - \sup \{ \eta \in (0, \pi/2) : (10.3) \text{ holds} \}.$$

We continue with some concrete examples, restricting ourselves to some model cases which can be treated here in a self-contained manner. More sophisticated examples will be discussed in the Notes at the end of the chapter. The examples presented here will be revisited several times as the chapter unfolds, since they serve well to illustrate the various concepts we are about to discuss.

Example 10.1.4 (First derivative). The first derivative $Af = f'$ with domain $D(A) = W^{1,p}(\mathbb{R}; X)$ is ω -sectorial on $L^p(\mathbb{R}; X)$, $1 \leq p < \infty$, for all $\frac{1}{2}\pi < \omega < \pi$. In order to prove this it suffices to recall that in Example G.4.4 we have checked that $-A$ generates the translation group, and therefore Example 10.1.2 implies that A is ω -sectorial for all $\frac{1}{2}\pi < \omega < \pi$.

Lemma 2.5.11 implies that A is injective. To show that $R(A)$ is dense for $p \in (1, \infty)$, first consider the scalar-valued case. The direct sum decomposition (10.1) implies that the range of A is dense in $L^p(\mathbb{R})$. Denoting the range in the scalar-valued case by R , the range of A in the vector-valued case contains $R \otimes X$, which is dense in $L^p(\mathbb{R}; X)$.

The operator A does not have dense range for $p = 1$. Indeed, approximating $f \in D(A)$ in the norm of $W^{1,1}(\mathbb{R}; X) = D(A)$ by test functions $f_n \in C_c^1(\mathbb{R}^d; X)$, one sees that

$$\langle Af, \mathbf{1} \otimes x^* \rangle = \lim_{n \rightarrow \infty} \langle f'_n, \mathbf{1} \otimes x^* \rangle = \lim_{r \rightarrow \infty} \int_{-r}^r \frac{d}{dt} \langle f_n(t), x^* \rangle dt = 0.$$

Since $\langle Af, \mathbf{1} \otimes x^* \rangle = \int_{\mathbb{R}} \langle Af(t), x^* \rangle dt = \langle \int_{\mathbb{R}} Af(t) dt, x^* \rangle$, it follows that $\int_{\mathbb{R}} Af(t) dt = 0$. Thus we see that $R(A)$ is contained in the proper closed subspace $\{g \in L^1(\mathbb{R}; X) : \int_{-\infty}^{\infty} g(t) dt = 0\}$ of $L^1(\mathbb{R}; X)$.

This example is somewhat deceptive in that it conceals a much better property of the first derivative, namely that the operators $\pm iA = \pm id/dx$ are *bisectorial* of angle 0. The notion of bisectoriality will be discussed at length in Section 10.6.

Example 10.1.5 (Laplacian on \mathbb{R}^d). In Example G.5.6 it is shown that the Laplacian Δ on $L^p(\mathbb{R}^d; X)$, $1 \leq p < \infty$, with domain $D(\Delta) = H^{2,p}(\mathbb{R}^d; X)$, generates an analytic C_0 -semigroup which is bounded on every sector Σ_η , $\eta \in (0, \frac{1}{2}\pi)$. Thus Example 10.1.3 implies that $-\Delta$ is sectorial of zero angle.

Let us show that Δ is injective. If $f \in D(\Delta)$ satisfies $\Delta f = 0$, then for all $x^* \in X^*$ the function $\langle f, x^* \rangle \in L^p(\mathbb{R}^d)$ belongs to the domain of the scalar-valued Laplacian and $\langle \Delta f, x^* \rangle = \Delta \langle f, x^* \rangle$. Thus it suffices to prove injectivity in the scalar case; for once we have that, in the vector-valued case it will imply that $\langle f, x^* \rangle = 0$ for all $x^* \in X^*$, and therefore $f = 0$ by Corollary 1.1.25.

Suppose then that the scalar-valued function $f \in D(\Delta)$ satisfies $\Delta f = 0$. Replacing f by $f * \phi$ for some test function (and noting that $f = 0$ if $f * \phi = 0$ for all test functions ϕ), we may assume that f is smooth. Then, by the maximum principle, $\Delta f = 0$ implies that f is constant. Since also $f \in L^p(\mathbb{R}^d)$, this is only possible if $f = 0$.

For $1 < p < \infty$ the density of the range of Δ can be proved as in Example 10.1.4. For $p = 1$, $\langle \Delta f, \mathbf{1} \otimes x^* \rangle = 0$ implies that $R(\Delta)$ is contained in the proper closed subspace $\{f \in L^1(\mathbb{R}^d; X) : \int_{\mathbb{R}^d} f(x) dx = 0\}$ of $L^1(\mathbb{R}^d; X)$.

10.1.b Basic properties

We now turn to the study of some basic properties of sectorial operators. Readers familiar with the topic may safely skip this discussion and proceed immediately to Section 10.2.a.

We begin with the simple observation that sectoriality can be checked on a half-line (see Lemma G.1.4):

Proposition 10.1.6. *A linear operator A is sectorial if and only if the open half-line $(-\infty, 0)$ is contained in $\varrho(A)$ and $\sup_{\lambda < 0} \|\lambda R(\lambda, A)\| < \infty$. More precisely, if*

$$\sup_{\lambda < 0} \|\lambda R(\lambda, A)\| =: M < \infty,$$

then A is sectorial with $\omega(A) \leq \pi - \arcsin(1/M)$.

Proposition 10.1.7 implies that $M \geq 1$, so that $\arcsin(1/M)$ is well defined. The next proposition gives useful characterisations of the kernel and the closure of the range of a sectorial operator.

Proposition 10.1.7. *Let A be sectorial.*

(1) For all $x \in \overline{D(A)}$,

$$\lim_{t \rightarrow \infty} t(t + A)^{-1}x = x, \quad \lim_{t \rightarrow \infty} A(t + A)^{-1}x = 0. \quad (10.4)$$

(2) For all $x \in \overline{R(A)}$,

$$\lim_{t \downarrow 0} t(t + A)^{-1}x = 0, \quad \lim_{t \downarrow 0} A(t + A)^{-1}x = x. \quad (10.5)$$

(3) $N(A) \cap \overline{R(A)} = \{0\}$ and $N(A) \oplus \overline{R(A)} = \{x \in X : \lim_{t \downarrow 0} t(t + A)^{-1}x \text{ exists}\}$.

Proof. (1): If $x \in D(A)$ then

$$\lim_{t \rightarrow \infty} t(t + A)^{-1}x - x = - \lim_{t \rightarrow \infty} A(t + A)^{-1}x = - \lim_{t \rightarrow \infty} \frac{1}{t} [t(t + A)^{-1}]Ax = 0$$

by the uniform boundedness of the operators $t(t + A)^{-1}$, $t > 0$. By an approximation argument using the uniform boundedness of the operators $t(t + A)^{-1}$ and $A(t + A)^{-1}$, the conclusion extends to all $x \in \overline{D(A)}$.

(2): If $x \in \mathbf{R}(A)$, say $x = Ay$ with $y \in \mathbf{D}(A)$, then

$$\lim_{t \downarrow 0} t(t+A)^{-1}x = -\lim_{t \downarrow 0} A(t+A)^{-1}x + x = \lim_{t \downarrow 0} t(1-t(t+A)^{-1})y = 0.$$

As in the proof of (1), by an approximation argument the conclusion extends to all $x \in \overline{\mathbf{R}(A)}$.

(3): For all $x \in \overline{\mathbf{R}(A)}$ by (2) we have $\lim_{t \downarrow 0} t(t+A)^{-1}x = 0$. On the other hand, for all $x \in \mathbf{N}(A)$ we have

$$\lim_{t \downarrow 0} t(t+A)^{-1}x = x - \lim_{t \downarrow 0} (t+A)^{-1}Ax = x.$$

It follows that $\mathbf{N}(A) \cap \overline{\mathbf{R}(A)} = \{0\}$.

Turning to the second assertion, by the above the asserted limits exist for all $x \in \mathbf{N}(A) \oplus \overline{\mathbf{R}(A)}$. Conversely, suppose $x \in X$ is such that $\lim_{t \downarrow 0} t(t+A)^{-1}x =: y$ exists. Then

$$A(t+A)^{-1}x = x - t(t+A)^{-1}x \rightarrow x - y$$

as $t \downarrow 0$. It follows that $x - y \in \overline{\mathbf{R}(A)}$. It also follows that $tA(t+A)^{-1}x \rightarrow 0$ as $t \downarrow 0$. Since the graph of A is closed, this implies that $y \in \mathbf{D}(A)$ and $Ay = 0$. Hence $x = y + (x - y)$ with $x - y \in \overline{\mathbf{R}(A)}$ and $y \in \mathbf{N}(A)$. \square

If Y is a subspace of X and A is linear operator on X with domain $\mathbf{D}(A)$, the part of A in Y is the linear operator A_Y on Y with domain $\mathbf{D}(A_Y)$ defined by

$$\begin{aligned} \mathbf{D}(A_Y) &:= \{y \in \mathbf{D}(A) \cap Y : Ay \in Y\}, \\ A_Y y &:= Ay, \quad y \in \mathbf{D}(A_Y). \end{aligned}$$

The intersection $\mathbf{D}(A) \cap \mathbf{R}(A)$ plays a central role in the whole subject. The next proposition shows, among other things, that the part of A in the closure of this subspace has particularly good properties.

Proposition 10.1.8. *Let A be ω -sectorial for some $0 < \omega < \pi$.*

- (1) $\mathbf{D}(A) \cap \mathbf{R}(A) = \overline{\mathbf{R}(A(I+A)^{-2})}$.
- (2) $\overline{\mathbf{D}(A) \cap \mathbf{R}(A)} = \overline{\mathbf{D}(A)} \cap \overline{\mathbf{R}(A)} = \overline{\mathbf{R}(A(I+A)^{-2})}$.
- (3) *The part of A in $\overline{\mathbf{D}(A) \cap \mathbf{R}(A)}$ is closed, densely defined, injective, has dense range, and is ω -sectorial.*
- (4) *If A is densely defined, then $\overline{\mathbf{D}(A) \cap \mathbf{R}(A)} = \overline{\mathbf{R}(A)}$.*

Proof. (1): For $x \in X$, the identity

$$A(I+A)^{-2}x = (I+A)^{-1}A(I+A)^{-1}x$$

shows “ \supseteq ”. If $x \in \mathbf{D}(A) \cap \mathbf{R}(A)$, then $(I+A)x \in \mathbf{R}(A)$, say $(I+A)x = Ay$ for some $y \in \mathbf{D}(A)$. Let $z := (I+A)y$. Then

$$x = (I + A)^{-1}Ay = A(I + A)^{-2}z.$$

(2): It suffices to prove the inclusion $\overline{D(A)} \cap \overline{R(A)} \subseteq \overline{D(A) \cap R(A)}$. Let $x \in \overline{D(A)} \cap \overline{R(A)}$ and fix $\varepsilon > 0$. By (10.4) we can find $t > 0$ such that

$$\|x - t(t + A)^{-1}x\| < \frac{\varepsilon}{2}.$$

Since $y = t(t + A)^{-1}x$ belongs to $\overline{R(A)}$, by (10.5) we can find $s > 0$ such that

$$\|y - A(s + A)^{-1}y\| < \frac{\varepsilon}{2}.$$

It follows that

$$\|x - tA(s + A)^{-1}(t + A)^{-1}x\| < \varepsilon$$

and the result follows since $tA(s + A)^{-1}(t + A)^{-1}x \in D(A) \cap R(A)$.

(3): Let us write $Y = \overline{D(A) \cap R(A)}$ for brevity and denote by A_Y the part of A in Y . Since A is closed it is clear that A_Y is closed. Since $(\lambda - A)^{-1}$ maps $D(A) \cap R(A)$ into itself, it also maps Y into itself, and from this it follows that if $\lambda \in \varrho(A)$ then $\lambda \in \varrho(A_Y)$ and $(\lambda - A_Y)^{-1} = (\lambda - A)^{-1}|_Y$. As a result, A_Y is ω -sectorial on Y .

We prove next that A_Y has dense range in Y and is injective. If $y \in D(A) \cap R(A)$, then by (10.5),

$$y = \lim_{t \downarrow 0} A(t + A)^{-1}y = \lim_{t \downarrow 0} A_Y(t + A)^{-1}y$$

belongs to $\overline{R(A_Y)}$. This being true for all y in the dense subspace $D(A) \cap R(A)$ of Y , it follows that $\overline{R(A_Y)} = Y$. By the result of Proposition 10.1.7(2) it follows that $N(A_Y) = \{0\}$.

We show next that $D(A_Y)$ is dense in Y . If $y \in D(A) \cap R(A)$, then $\lim_{t \downarrow 0} A(t + A)^{-1}y = y$ by (10.5). Moreover, for each $t > 0$,

$$\lim_{n \rightarrow \infty} n(n + A)^{-1}A(t + A)^{-1}y = A(t + A)^{-1}y;$$

here we used that $A(t + A)^{-1}y = (t + A)^{-1}Ay$ belongs to $D(A)$ together with (10.4). Since the vectors $n(n + A)^{-1}A(t + A)^{-1}y$ belong to $D(A_Y)$ (because

$$nA(n + A)^{-1}A(t + A)^{-1}y = nA(t + A)^{-1}y - n^2A(n + A)^{-1}(t + A)^{-1}y$$

belongs to Y), it follows that $A(t + A)^{-1}y \in \overline{D(A_Y)}$ for all $t > 0$, and therefore also $y \in \overline{D(A_Y)}$. This proves that $D(A) \cap R(A) \subseteq \overline{D(A_Y)}$ and therefore $\overline{D(A_Y)} = Y$.

(4): If A is densely defined, then by (2) we have $\overline{D(A) \cap R(A)} = \overline{D(A)} \cap \overline{R(A)} = \overline{R(A)}$. \square

The final result of this subsection shows that in reflexive Banach spaces X , sectorial operators are automatically densely defined, so it always holds that $\overline{D(A) \cap R(A)} = \overline{R(A)}$. Even more importantly, X decomposes as the direct sum of $N(A)$ and $\overline{R(A)}$:

Proposition 10.1.9. *Let A be an ω -sectorial operator on a reflexive Banach space X for some $0 < \omega < \pi$. Then A is densely defined and therefore*

$$\overline{D(A) \cap R(A)} = \overline{R(A)}.$$

Furthermore, we have a direct sum decomposition

$$X = N(A) \oplus \overline{R(A)}.$$

Proof. We begin with the proof of the direct sum decomposition. Since X is reflexive the resolvent operators $(t_0 + A)^{-1}$ are weakly compact for all $t_0 > 0$. By the *resolvent identity*

$$R(\lambda, A) - R(\mu, A) = (\mu - \lambda)R(\lambda, A)R(\mu, A), \quad \lambda, \mu \in \rho(A),$$

we have

$$(t + A)^{-1} = (t_0 + A)^{-1}[I + (t_0 - t)(t + A)^{-1}],$$

which implies that for each $x \in X$, $\{t(t + A)^{-1}x : t \in (0, 1)\}$ is contained in some scalar multiple of the relatively compact set $(t_0 + A)^{-1}B_X$, with B_X the unit ball of X . As a consequence, for every $x \in X$ we may extract a subsequence $t_n \downarrow 0$ such that the weak limit $\lim_{n \rightarrow \infty} t_n(t_n + A)^{-1}x =: y$ exists. Using that closed subspaces are weakly closed, we may now argue as in the proof of Proposition 10.1.7(3) to conclude that $x = y + (x - y)$ with $y \in N(A)$ and $x - y \in \overline{R(A)}$.

To prove that A is densely defined we will show that the part A_Y is densely defined in $Y := \overline{R(A)}$. Since $N(A)$ is contained in $D(A)$ the decomposition then implies that A is densely defined in X .

Fix an arbitrary $y \in Y$. Since the operators $n(n + A_Y)^{-1}$ are uniformly bounded, we may select a subsequence $n_k \rightarrow \infty$ such that $n_k(n_k + A_Y)^{-1}y$ is weakly convergent, say to $x \in X$. Then $x \in Y$ and, by the resolvent identity,

$$\begin{aligned} (1 + A_Y)^{-1}y &= \lim_{k \rightarrow \infty} n_k(n_k + A_Y)^{-1}(1 + A_Y)^{-1}x \\ &= \lim_{k \rightarrow \infty} \frac{n_k(n_k + A_Y)^{-1}x + n_k(1 + A_Y)^{-1}x}{\mu + n_k} = (1 + A_Y)^{-1}x, \end{aligned}$$

where the limits are taken in the weak topology. It follows that $y = x = \lim_{k \rightarrow \infty} n_k R(-n_k, A_Y)y$ weakly, which shows that y belongs to the weak closure of $D(A_Y)$. Since this equals the strong closure by the Hahn–Banach theorem, this completes the proof. \square

Remark 10.1.10. The proof of the direct sum decomposition extends to arbitrary Banach spaces as long as A has weakly compact resolvent operators (the resolvent identity implies that if $R(\lambda, A)$ is weakly compact for some $\lambda \in \varrho(A)$, then it is weakly compact for all $\lambda \in \varrho(A)$).

As is shown in the following example, a general sectorial operator A need not be densely defined and the direct sum decomposition of Proposition 10.1.9 may fail.

Example 10.1.11. Consider the bounded linear operator A on $X = C[0, 1]$ by $Af(s) = sf(s)$. This operator is injective and sectorial of angle zero, and $\mathbf{N}(A) \oplus \overline{\mathbf{R}(A)} = \overline{\mathbf{R}(A)} = \{f \in C[0, 1] : f(0) = 0\}$ is a proper subspace of $C[0, 1]$.

The inverse operator A^{-1} with $\mathbf{D}(A^{-1}) = \{f \in C[0, 1] : f(0) = 0\}$ provides an example of a sectorial operator of angle zero which does not have a dense domain.

10.2 Construction of the H^∞ -calculus

The construction of the H^∞ -calculus proceeds in two stages. The first generalises the Dunford functional calculus

$$f(A) = \frac{1}{2\pi i} \int_{\Gamma} f(z)R(z, A) dz$$

for bounded operators A and f a holomorphic function in a neighbourhood of its spectrum $\sigma(A)$, to sectorial operators A . The requirement will be that f belongs to the Hardy space $H^1(\Sigma_\sigma)$, where $\omega(A) < \sigma < \pi$. This is by itself not a very useful calculus, and the second stage of the construction consists of extending the Dunford calculus to suitable *bounded* holomorphic functions on Σ , that is, for functions in the Hardy space $H^\infty(\Sigma)$. Whether or not this is possible depends on the operator A , and A is said to have a *bounded H^∞ -functional calculus* if there exists a constant M such that

$$\|f(A)\| \leq M\|f\|_\infty, \quad f \in H^1(\Sigma) \cap H^\infty(\Sigma). \quad (10.6)$$

When (10.6) holds, the restriction of the H^1 -calculus to functions in $H^1(\Sigma) \cap H^\infty(\Sigma)$ can be extended to a calculus for functions in $H^\infty(\Sigma)$ by an approximation argument.

The preliminary H^1 -calculus, which we will call the *Dunford calculus* in view of its close analogy with the Dunford calculus for bounded linear operators, is “easy” in the sense that it is defined, for any sectorial operator, in terms of absolutely convergent integrals. In contrast, the H^∞ -calculus involves singular integrals which do not always converge. For operators for which they do converge, the H^∞ -calculus provides a powerful tool with a wealth of non-trivial applications.

10.2.a The Dunford calculus

We begin by setting up a preliminary calculus $f \mapsto f(A)$ for sectorial operators A and functions f which are holomorphic and integrable on an open sector whose opening angle is somewhat larger than the angle of sectoriality of A . This calculus, the so-called *Dunford calculus* of A , involves an absolutely convergent integral of Dunford type.

Definition 10.2.1 (The Hardy spaces $H^p(\Sigma_\sigma)$). Let $1 \leq p \leq \infty$ and $0 < \sigma < \pi$. The Banach space of all holomorphic functions $f : \Sigma_\sigma \rightarrow \mathbb{C}$ for which

$$\|f\|_{H^p(\Sigma_\sigma)} := \sup_{|\nu| < \sigma} \|t \mapsto f(e^{i\nu}t)\|_{L^p(\mathbb{R}_+, \frac{dt}{t})} < \infty$$

is denoted by $H^p(\Sigma_\sigma)$.

Appendix H contains some generalities about holomorphic functions on sectors which will be used freely in this chapter. Among other things, it is shown there that by restriction, every function $f \in H^p(\Sigma_\sigma)$ with $1 \leq p \leq \infty$ belongs to $H^\infty(\Sigma_{\sigma'})$ for all $0 < \sigma' < \sigma$.

Suppose now that A is sectorial, with angle of sectoriality $\omega(A)$. Recall that this means that for all $\omega(A) < \sigma < \pi$ we have $\mathbb{C}\overline{\Sigma_\sigma} \subseteq \varrho(A)$ and

$$M_{\sigma,A} := \sup_{z \in \mathbb{C}\overline{\Sigma_\sigma}} \|zR(z,A)\| < \infty.$$

We will refer to $M_{\sigma,A}$ as the σ -sectoriality constant of A . This constant depends continuously on $\sigma \in (\omega(A), \pi)$.

For functions $f \in H^1(\Sigma_\sigma)$ we may define a bounded operator $f(A)$ by the Dunford integral

$$f(A) := \frac{1}{2\pi i} \int_{\partial\Sigma_\nu} f(z)R(z,A) dz, \tag{10.7}$$

where $\omega(A) < \nu < \sigma$ is chosen arbitrarily; the boundary $\partial\Sigma_\nu$ is oriented ‘downwards’ so as to have the spectrum of A at the left-hand side while traversing it. The estimate

$$\|f(A)\| \leq \frac{M_{\nu,A}}{2\pi} \int_{\partial\Sigma_\nu} |f(z)| \frac{|dz|}{|z|} \leq \frac{M_{\nu,A}}{\pi} \|f\|_{H^1(\Sigma_\sigma)}$$

shows that the integral in (10.7) is well defined as a Bochner integral in $\mathcal{L}(X)$. Taking the infimum over all $\nu \in (\omega(A), \sigma)$ gives the bound

$$\|f(A)\| \leq \frac{M_{\sigma,A}}{\pi} \|f\|_{H^1(\Sigma_\sigma)}. \tag{10.8}$$

Next we show that the definition of $f(A)$ is independent of the choice of $\nu \in (\omega(A), \sigma)$. Letting $\text{Arc}(r, \eta) = \{re^{iy} \in \mathbb{C} : |y| < \eta\}$ for $r > 0$ and $\eta \in (0, \sigma)$, we have

$$\int_{\text{Arc}(r,\eta)} |f(z)| \frac{|dz|}{|z|} = \int_{-\eta}^{\eta} |f(re^{iy})| |y| dy \rightarrow 0,$$

as $r \rightarrow \infty$ or $r \downarrow 0$ by Proposition H.2.5. Therefore, since $z \mapsto f(z)R(z, A)$ is holomorphic on $\Sigma_\sigma \setminus \overline{\Sigma_{\omega(A)}}$, one can use Cauchy's theorem to see that the right-hand side of (10.7) does not depend on the choice of $\nu \in (\omega(A), \sigma)$.

By a change of variables, for all $t > 0$ we have $\|z \mapsto f(tz)\|_{H^1(\Sigma_\sigma)} = \|f\|_{H^1(\Sigma_\sigma)}$ and consequently (10.8) self-improves to

$$\sup_{t>0} \|f(tA)\| \leq \frac{M_{\sigma,A}}{\pi} \|f\|_{H^1(\Sigma_\sigma)}. \quad (10.9)$$

Theorem 10.2.2 (Dunford calculus). *Let A be a sectorial operator on a Banach space X and let $\omega(A) < \sigma < \pi$. The mapping $f \mapsto f(A)$ from $H^1(\Sigma_\sigma)$ to $\mathcal{L}(X)$ is linear, and multiplicative in the sense that if $f, g \in H^1(\Sigma_\sigma)$ are such that $fg \in H^1(\Sigma_\sigma)$, then*

$$(fg)(A) = f(A)g(A).$$

It has the following convergence property: if the functions $f_n, f \in H^\infty(\Sigma_\sigma)$ are uniformly bounded and satisfy $f_n(z) \rightarrow f(z)$ for all $z \in \Sigma_\sigma$, then for all $g \in H^1(\Sigma_\sigma)$ we have

$$\lim_{n \rightarrow \infty} (f_n g)(A) = (fg)(A). \quad (10.10)$$

Proof. Linearity of the mapping $f \mapsto f(A)$ is clear from the definitions. To prove multiplicativity we choose angles $\omega(A) < \nu' < \nu < \sigma' < \sigma$. Then, for $f \in H^1(\Sigma_\sigma)$ and $g \in H^1(\Sigma_\sigma)$ such that $fg \in H^1(\Sigma_\sigma)$, the restrictions to $\Sigma_{\sigma'}$ satisfy $f \in H^1(\Sigma_{\sigma'}) \cap H^\infty(\Sigma_{\sigma'})$ and $g \in H^1(\Sigma_{\sigma'})$. By the resolvent identity we obtain

$$\begin{aligned} f(A)g(A) &= \left(\frac{1}{2\pi i}\right)^2 \left(\int_{\partial\Sigma_{\nu'}} f(\mu)R(\mu, A) d\mu\right) \left(\int_{\partial\Sigma_{\nu'}} g(\lambda)R(\lambda, A) d\lambda\right) \\ &= \left(\frac{1}{2\pi i}\right)^2 \int_{\partial\Sigma_{\nu'}} \int_{\partial\Sigma_{\nu'}} \frac{f(\mu)g(\lambda)}{\lambda - \mu} [R(\mu, A) - R(\lambda, A)] d\mu d\lambda \\ &= \frac{1}{2\pi i} \int_{\partial\Sigma_{\nu'}} g(\lambda) \left[\frac{1}{2\pi i} \int_{\partial\Sigma_{\nu'}} \frac{f(\mu)}{\mu - \lambda} d\mu\right] R(\lambda, A) d\lambda \\ &\quad + \frac{1}{2\pi i} \int_{\partial\Sigma_{\nu'}} f(\mu) \left[\frac{1}{2\pi i} \int_{\partial\Sigma_{\nu'}} \frac{g(\lambda)}{\lambda - \mu} d\lambda\right] R(\mu, A) d\mu \\ &= \frac{1}{2\pi i} \int_{\partial\Sigma_{\nu'}} g(\lambda) f(\lambda) R(\lambda, A) d\lambda = (fg)(A). \end{aligned}$$

Here we used that

$$\frac{1}{2\pi i} \int_{\partial\Sigma_{\nu'}} \frac{f(\mu)}{\mu - \lambda} d\mu = f(\lambda)$$

by Cauchy's formula and

$$\frac{1}{2\pi i} \int_{\partial\Sigma_{\nu'}} \frac{g(\lambda)}{\lambda - \mu} d\lambda = 0$$

by Cauchy's theorem since $\lambda \mapsto g(\lambda)(\lambda - \mu)^{-1}$ is holomorphic on $\Sigma_{\nu'}$.

The convergence property (10.10) follows from the dominated convergence theorem. \square

Proposition 10.2.3. *Let A be a sectorial operator and let*

$$\zeta_{\lambda_1, \dots, \lambda_n}(z) := z \prod_{j=1}^n \frac{1}{\lambda_j - z},$$

where $n \geq 2$ and $\lambda_j \neq 0$ satisfies $|\arg(\lambda_j)| > \omega(A)$, $j = 1, \dots, n$. Then

$$\zeta_{\lambda_1, \dots, \lambda_n}(A) = A \prod_{j=1}^n R(\lambda_j, A).$$

Proof. By the convergence property of the Dunford calculus we may assume that $\lambda_i \neq \lambda_j$ for all $i \neq j$. Let $\omega(A) < \nu < \min_{1 \leq j \leq n} |\arg(\lambda_j)|$ and put $\Sigma_\nu(\varepsilon) := \Sigma_\nu \cup B(0, \varepsilon)$ with $0 < \varepsilon < \min_{1 \leq j \leq n} |\lambda_j|$. Set $\psi(z) := \prod_{j=1}^n \frac{1}{\lambda_j - z}$. By Cauchy's theorem,

$$\zeta_{\lambda_1, \dots, \lambda_n}(A)x = \frac{1}{2\pi i} \int_{\partial\Sigma_\nu} \psi(z)zR(z, A) dz = \frac{1}{2\pi i} \int_{\partial\Sigma_\nu(\varepsilon)} \psi(z)zR(z, A) dz.$$

Writing $zR(z, A) = I + AR(z, A)$ and applying Cauchy's theorem to the function ψ and the residue theorem to the function $\psi(\cdot)AR(\cdot, A)$ (which has poles at $\lambda_1, \dots, \lambda_n$), we obtain

$$\begin{aligned} \zeta_{\lambda_1, \dots, \lambda_n}(A)x &= \frac{1}{2\pi i} \int_{\partial\Sigma_\nu(\varepsilon)} \psi(z) dz + \frac{1}{2\pi i} \int_{\partial\Sigma_\nu(\varepsilon)} \psi(z)AR(z, A) dz \\ &= 0 + \sum_{k=1}^n \prod_{j \neq k} \frac{1}{\lambda_j - \lambda_k} AR(\lambda_k, A) = A \prod_{j=1}^n R(\lambda_j, A), \end{aligned}$$

where the latter follows by repeated application of the resolvent identity. \square

As a first application of the part of the lemma we continue with a very useful formula that will play an important role in the developments in later sections, the so-called Calderón reproducing formula. The second part of the proof uses the following elementary lemma, which will also be useful at other places.

Lemma 10.2.4. *Let $\sigma \in (0, \pi)$. For every $z \in \Sigma_\sigma$ we have*

$$|1 + z| \geq (|z| \vee 1) \sin(\sigma \vee \frac{\pi}{2}) = \begin{cases} |z| \vee 1, & \text{if } \sigma \in (0, \frac{1}{2}\pi], \\ (|z| \vee 1) \sin(\sigma), & \text{if } \sigma \in (\frac{1}{2}\pi, \pi). \end{cases}$$

Proof. Let $z = re^{i\nu}$ with $r > 0$ and $\nu \in (-\sigma, \sigma)$. If $|\nu| \leq \frac{1}{2}\pi$, then

$$|1 + z| = ((1 + r^2 + 2r \cos(\nu))^{1/2} \geq (1 + r^2)^{1/2} \geq r \vee 1.$$

This estimate gives the required estimate if $0 < \sigma \leq \frac{1}{2}\pi$.

Next consider the case $\frac{1}{2}\pi < \sigma < \pi$ and $\frac{1}{2}\pi < |\nu| < \sigma$. If $r \geq 1$, then

$$|1 + z| \geq |\Im(1 + z)| = r|\sin(\nu)| \geq r|\sin(\sigma)|.$$

If $r \in (0, 1)$, then

$$|1 + z|^2 = 1 + r^2 + 2r \cos(\nu) \geq 1 - \cos^2(\nu) = \sin^2(\nu) \geq \sin^2(\sigma).$$

This proves the remaining case of the estimate. \square

Proposition 10.2.5 (Calderón reproducing formula I). *Let A be a sectorial operator, let $\omega(A) < \sigma < \pi$, and assume $f \in H^1(\Sigma_\sigma)$ satisfies*

$$\int_0^\infty f(t) \frac{dt}{t} = 1.$$

Then for all $x \in \mathcal{D}(A) \cap \mathcal{R}(A)$ we have

$$\int_0^\infty f(tA)x \frac{dt}{t} = x,$$

the integral being convergent as an improper integral in X . If $z \mapsto \log(z)f(z)$ belongs to $H^1(\Sigma_\sigma)$, the same conclusion holds for all $x \in \overline{\mathcal{D}(A) \cap \mathcal{R}(A)}$.

The growth condition in second part of the statement holds in particular if

$$|f(z)| \lesssim \min\{|z|^{-\alpha}, |z|^\alpha\}$$

for some $\alpha > 0$ and all $z \in \Sigma_\sigma$. The additional assumption on f can be avoided if A has a bounded $H^\infty(\Sigma_\sigma)$ -calculus (see Proposition 10.2.15 below).

Proof. Fix an arbitrary $x \in \mathcal{D}(A) \cap \mathcal{R}(A)$. By analytic continuation the identity $\int_0^\infty f(tz) \frac{dt}{t} = 1$ extends to $z \in \Sigma_\sigma$. Put

$$\varphi_{a,b}(z) := \int_a^b f(zt) \frac{dt}{t}.$$

This function is holomorphic on Σ_σ . For $|\nu| < \sigma$ we use Fubini's theorem and a substitution to estimate

$$\int_0^\infty |\varphi_{a,b}(se^{i\nu})| \frac{ds}{s} \leq \int_a^b \int_0^\infty |f(tse^{i\nu})| \frac{ds}{s} \frac{dt}{t} \leq \log(b/a) \|f\|_{H^1(\Sigma_\sigma)}.$$

Therefore $\varphi_{a,b} \in H^1(\Sigma_\sigma)$. Clearly, we have $\varphi_{a,b}(z) \rightarrow 1$ as $a \downarrow 0$ and $b \rightarrow \infty$. Let $\omega(A) < \nu < \sigma$. By Fubini's theorem,

$$\begin{aligned} \varphi_{a,b}(A)x &= \frac{1}{2\pi i} \int_{\partial\Sigma_\nu} \varphi_{a,b}(z)R(z, A)x \, dz \\ &= \frac{1}{2\pi i} \int_a^b \int_{\partial\Sigma_\nu} f(tz)R(z, A)x \, dz \frac{dt}{t} = \int_a^b f(tA)x \frac{dt}{t}. \end{aligned} \tag{10.11}$$

We recall from Propositions 10.1.8 and 10.2.3 that $D(A) \cap R(A) = R(\zeta(A))$ with $\zeta(A) = A(I + A)^{-2}$, so we may write $x = \zeta(A)y$ for some $y \in X$. By (10.11) and Theorem 10.2.2 we then obtain

$$\int_a^b f(tA)x \frac{dt}{t} = \varphi_{a,b}(A)\zeta(A)y = (\varphi_{a,b}\zeta)(A)y \rightarrow \zeta(A)y = x$$

as $a \downarrow 0$ and $b \rightarrow \infty$. This completes the proof of the first assertion.

Assume now that $z \mapsto \log(z)f(z)$ belongs to $H^1(\Sigma_\sigma)$. We claim that

$$\sup_{0 < a \leq b < \infty} \left\| \int_a^b f(tA) \frac{dt}{t} \right\| \leq C_{f,\sigma}, \tag{10.12}$$

with an explicit bound on the constant $C_{f,\sigma}$. The improper convergence of $\int_0^\infty f(tA)x \frac{dt}{t}$ for $x \in \overline{D(A) \cap R(A)}$ then follows from the first part of the proof and an approximation argument.

For all $z \in \Sigma_\sigma$,

$$\begin{aligned} \varphi_{a,b}(z) &= \int_0^b f(tz) \frac{dt}{t} - \int_0^a f(tz) \frac{dt}{t} \\ &= \int_0^1 f(tbz) \frac{dt}{t} - \int_0^1 f(taz) \frac{dt}{t} =: h(bz) - h(az) \end{aligned}$$

with $h(z) := \int_0^1 f(tz) \frac{dt}{t}$. Set $g(z) := \int_1^\infty f(tz) \frac{dt}{t}$ and note that

$$\psi(z) := h(z) - \frac{z}{1+z} = -g(z) + \frac{1}{1+z}, \quad z \in \Sigma_\sigma.$$

We claim that $\psi \in H^1(\Sigma_\sigma)$. To show this we use both expressions for ψ on different parts of the H^1 -norm. We have, for $0 < |\nu| < \sigma$,

$$\int_0^1 |\psi(se^{i\nu})| \frac{ds}{s} \leq \int_0^1 |h(se^{i\nu})| \frac{ds}{s} + \int_0^1 \frac{1}{|1+se^{i\nu}|} ds.$$

Using the inequality $|1+se^{i\nu}| \geq \sin(\sigma \vee \frac{1}{2}\pi)$ from Lemma 10.2.4, the second integral on the right-hand side is bounded by $1/\sin(\sigma \vee \frac{1}{2}\pi)$. For the first integral we note that

$$\int_0^1 |h(se^{i\nu})| \frac{ds}{s} \leq \int_0^1 \int_0^1 |f(ste^{i\nu})| \frac{dt}{t} \frac{ds}{s}$$

$$\begin{aligned}
&= \int_0^1 \int_0^1 |f(st e^{i\nu})| \frac{ds}{s} \frac{dt}{t} \\
&= \int_0^1 \int_0^s |f(te^{i\nu})| \frac{ds}{s} \frac{dt}{t} \\
&= \int_0^1 \int_t^1 |f(te^{i\nu})| \frac{ds}{s} \frac{dt}{t} = \int_0^1 |f(te^{i\nu}) \log(t)| \frac{dt}{t}.
\end{aligned}$$

On the interval $(1, \infty)$ we have

$$\int_1^\infty |\psi(se^{i\nu})| \frac{ds}{s} \leq \int_1^\infty |g(se^{i\nu})| \frac{dt}{t} + \int_1^\infty \frac{1}{|1 + se^{i\nu}|} \frac{ds}{s}.$$

Using again that $|1 + se^{i\nu}| \geq s \sin(\sigma \vee \frac{1}{2}\pi)$, the latter integral is bounded by $1/\sin(\sigma \vee \frac{1}{2}\pi)$. In the same way as before we see that

$$\int_1^\infty |g(se^{i\nu})| \frac{dt}{t} \leq \int_1^\infty |f(te^{i\nu}) \log(t)| \frac{dt}{t}.$$

It follows that $\psi \in H^1(\Sigma_\sigma)$ with

$$\|\psi\|_{H^1(\Sigma_\sigma)} \leq \|z \mapsto f(z) \log(z)\|_{H^1(\Sigma_\sigma)} + C_\sigma,$$

where $C_\sigma = 2/\sin(\sigma \vee \frac{1}{2}\pi)$.

Let $\omega(A) < \nu < \sigma$. By the above estimates, for all $t > 0$ we have

$$\begin{aligned}
\|\psi(tA)\| &\leq \frac{1}{2\pi} \int_{\partial\Sigma_\nu} |\psi(tz)| \|zR(z, A)\| \frac{|dz|}{|z|} \\
&\leq \frac{M_{\nu, A}}{2\pi} \int_{\partial\Sigma_\nu} |\psi(z)| \frac{|dz|}{|z|} \leq \frac{M_{\nu, A}}{2\pi} (\|z \mapsto f(z) \log(z)\|_{H^1(\Sigma_\sigma)} + C_\sigma)
\end{aligned}$$

Since

$$\varphi_{a,b}(z) = h(bz) - h(az) = \psi(bz) - \psi(az) + \frac{(b-a)z}{(1+bz)(1+az)},$$

we can use the linearity of the Dunford calculus, Proposition 10.2.3 and the resolvent identity to obtain

$$\begin{aligned}
\varphi_{a,b}(A) &= \psi(bA) - \psi(aA) + (b-a)A(1+bA)^{-1}(1+aA)^{-1} \\
&= \psi(bA) - \psi(aA) + (1+aA)^{-1} - (1+bA)^{-1}.
\end{aligned}$$

Hence by the previous estimates (and taking the infimum over all ν),

$$\begin{aligned}
\|\varphi_{a,b}(A)\| &\leq \|\psi(bA)\| + \|\psi(aA)\| + \|(1+bA)^{-1}\| + \|(1+aA)^{-1}\| \\
&\leq 2M_{\sigma, A} \left(\frac{\|z \mapsto f(z) \log(z)\|_{H^1(\Sigma_\sigma)} + C_\sigma}{2\pi} + 1 \right).
\end{aligned}$$

This completes the proof of (10.12). \square

As an application of the second part of Proposition 10.2.3 we describe a useful approximation procedure.

Proposition 10.2.6. *For $n \geq 1$ the functions*

$$\zeta_n(z) := \frac{n}{n+z} - \frac{1}{1+nz}$$

belong to $H^1(\Sigma_\sigma) \cap H^\infty(\Sigma_\sigma)$ for all $0 < \sigma < \pi$, and they satisfy

$$\|\zeta_n\|_{H^\infty(\Sigma_\sigma)} \leq \frac{1}{\sin(\sigma \vee \frac{1}{2}\pi)}.$$

In particular, for $0 < \sigma \leq \frac{1}{2}\pi$ we have $\|\zeta_n\|_{H^\infty(\Sigma_\sigma)} \leq 1$. Moreover, for any sectorial operator A ,

(1) *we have*

$$\zeta_n(A) = n(n+A)^{-1} - \frac{1}{n} \left(\frac{1}{n} + A \right)^{-1}$$

and for all $\sigma > \omega(A)$

$$\sup_{n \geq 1} \|\zeta_n(A)\| \leq 2M_{\sigma,A};$$

(2) *for all $x \in X$ we have $\zeta_n(A)x \in \mathcal{D}(A) \cap \mathcal{R}(A)$;*

(3) *for all $x \in \mathcal{D}(A) \cap \mathcal{R}(A)$ we have*

$$\lim_{n \rightarrow \infty} \zeta_n(A)x = x.$$

Proof. That $\zeta_n \in H^1(\Sigma_\sigma)$ is clear by writing

$$\zeta_n(z) = \frac{(n^2 - 1)z}{(n+z)(1+nz)}. \tag{10.13}$$

To obtain the bound for their norms in $H^\infty(\Sigma_\sigma)$ write

$$\zeta_n(z) = \frac{n^2 - 1}{n^2} \frac{1}{\left(1 + \frac{z}{n}\right)\left(1 + \frac{1}{nz}\right)}.$$

For $z = re^{i\nu}$ with $r > 0$ and $|\nu| < \sigma$, we have

$$\begin{aligned} w := n^2 \left(1 + \frac{z}{n}\right) \left(1 + \frac{1}{nz}\right) &= n^2 + 1 + nre^{i\nu} + \frac{n}{r}e^{-i\nu} \\ &= n^2 + 1 + n\left(r + \frac{1}{r}\right) \cos(\nu) + in\left(r - \frac{1}{r}\right) \sin(\nu). \end{aligned}$$

Therefore, if $\nu \in [0, \pi/2]$, then $\cos(\nu) \geq 0$ and hence $|\zeta(z)| \leq \frac{n^2-1}{n^2+1} \leq 1$. It remains to check that for $\nu \in [\pi/2, \pi]$, we have $|\zeta(z)| \leq 1/\sin(\nu)$. The latter holds if and only if

$$|w|^2 \geq (n^2 - 1)^2 \sin^2(\nu).$$

The latter inequality indeed holds, for it is elementary to verify that

$$|w|^2 - (n^2 - 1)^2 \sin^2(\nu) = \frac{1}{r^2} \left((n^2 + 1)r \cos(\nu) + n(r^2 + 1) \right)^2 \geq 0.$$

(1): The identity for the operators $\zeta_n(A)$ follows from (10.13) and Proposition 10.2.3, and their uniform boundedness with constant $2M_{\sigma,A}$ from the sectoriality of A .

(2): That $\zeta_n(A)x \in D(A)$ is immediate from the identity in (1), and that $\zeta_n(A)x \in R(A)$ follows by rewriting

$$\zeta_n(A) = (n^2 - 1)A(n + A)^{-1}(1 + nA)^{-1}.$$

(3): This is immediate from the assertions in part (1) and the convergence results of (10.4) and (10.5). \square

The analytic semigroup generated by a densely defined sectorial operator

It is shown in Theorem G.5.2 that if A is a densely defined sectorial operator on a Banach space X , then $-A$ generates a bounded analytic C_0 -semigroup $(S(t))_{t \geq 0}$ which is given by the inverse Laplace transform representation

$$S(t)x = \frac{1}{2\pi i} \int_\Gamma e^{tz} R(z, -A)x \, dz, \quad t > 0, \quad x \in X,$$

where Γ is the upwards oriented contour in the left-half plane specified in the theorem.

Here we wish to point out that the operators $S(t)$ can also be constructed directly from the Dunford calculus of A . This is not immediately obvious, as one cannot define them as $S(t) = \exp(-tA)$ using the exponential function $\exp(-tz)$: this function does not belong to $H^1(\Sigma_\sigma)$ for any $0 < \sigma < \pi$. This defect can be remedied by compensating the non-integrability near 0 by an additional additive term

$$\exp(-tz) = \left(\exp(-tz) - \frac{1}{1 + tz} \right) + \frac{1}{1 + tz}$$

and interpreting $\frac{1}{1+t} \cdot (A)$ as $(I + tA)^{-1}$.

Proposition 10.2.7. *Let A be a densely defined sectorial operator satisfying $\omega(A) < \frac{1}{2}\pi$, let $\omega(A) < \sigma < \frac{1}{2}\pi$ and $\eta \in (0, \frac{1}{2}\pi - \sigma)$, and denote by $(S(\zeta))_{\zeta \in \Sigma_\eta}$ the bounded analytic C_0 -semigroup generated by $-A$. Then for all $z \in \Sigma_\eta$ the following identity holds:*

$$S(\zeta) - (1 + \zeta A)^{-1} = f_\zeta(A),$$

where

$$f_\zeta(z) = \exp(-\zeta z) - \frac{1}{1 + \zeta z}.$$

Observe that $z \mapsto \exp(-z) - \frac{1}{1+z}$ belongs to $H^1(\Sigma_{\sigma+\eta})$, so f_ζ belongs to $H^1(\Sigma_\sigma)$ and $f_\zeta(A)$ can be defined through the Dunford calculus of A .

Proof. It suffices to prove the identity for $\zeta = t > 0$, since then the result for $\zeta \in \Sigma_\eta$ follows by analytic continuation. Fix $t > 0$ and $0 < \varepsilon < 1/t$, and put $\Sigma_\eta(\varepsilon) := \Sigma_\eta \cup B(0, \varepsilon)$. By Cauchy's theorem, the path of integration in the Dunford integral may be changed from $\partial\Sigma_\eta$ to $\partial\Sigma_\eta(\varepsilon)$ to obtain

$$\begin{aligned} f_t(A) &= \frac{1}{2\pi i} \int_{\partial\Sigma_\eta(\varepsilon)} f_t(z)R(z, A) \, dz \\ &= \frac{1}{2\pi i} \int_{\partial\Sigma_\eta(\varepsilon)} e^{-tz}R(z, A) \, dz - \frac{1}{2\pi i} \int_{\partial\Sigma_\eta(\varepsilon)} \frac{1}{1+tz}R(z, A) \, dz. \end{aligned}$$

After substituting $z \mapsto -z$, the first integral is seen to coincide with the inverse Laplace transform representation of $S(t)$ of Theorem G.5.2 (applied to $-A$). To evaluate the second integral we use the holomorphy of $z \mapsto R(z, A)x$ and Cauchy's theorem:

$$\begin{aligned} \frac{1}{2\pi i} \int_{\partial\Sigma_\nu(\varepsilon)} \frac{1}{1+tz}R(z, A) \, dz &= -\frac{1}{2\pi it} \int_\Gamma \frac{R(z, A)}{-t^{-1}-z} \, dz \\ &= -t^{-1}R(-t^{-1}, A) = (I + tA)^{-1}. \end{aligned}$$

This proves the identity $f_t(A) = S(t) - (1 + tA)^{-1}$. □

It is worth mentioning that for densely defined sectorial operators A satisfying $\omega(A) < \frac{1}{2}\pi$, the convergence assertions in parts (1) and (2) of Proposition 10.1.8 have counterparts in terms of the semigroup $(S(t))_{t \geq 0}$ generated by $-A$. As a rule of thumb, for $t \rightarrow \infty$ (resp. for $t \downarrow 0$) the limiting behaviour of $S(t)$ is the same as that for $A(t + A)^{-1} t \rightarrow \infty$ (resp. for $t \downarrow 0$), and also the same as that for $t(t + A)^{-1}$ for $t \downarrow 0$ (resp. for $t \rightarrow \infty$). Let us illustrate this by proving one of these correspondences: we will show that

$$\text{for all } x \in \overline{\mathbb{R}(A)} \text{ we have } \lim_{t \rightarrow \infty} S(t)x = 0.$$

By the inverse Laplace transform representation,

$$S(t)x = \frac{1}{2\pi i} \int_{\partial\Sigma_\eta(\varepsilon)} e^{tz}(z + A)^{-1}x \, dz = \frac{1}{2\pi i} \int_{\partial\Sigma_\eta(\varepsilon)} \frac{e^z}{z} \left[\frac{z}{t} \left(\frac{z}{t} + A \right)^{-1} \right] x \, dz,$$

where $\Sigma_\eta(\varepsilon)$ is as before. In the second identity we used Cauchy's theorem to justify that we did not change the path of integration. By repeating the proof of Proposition 10.1.7(2) *verbatim*, $\frac{z}{t}(\frac{z}{t} + A)^{-1}$ tends to 0 strongly as $t \rightarrow \infty$ on $\overline{\mathbb{R}(A)}$. Therefore the claim follows by dominated convergence.

We can push this idea a little further. Writing (cf. Proposition G.2.3) $S(t)x - x = -\int_0^t AS(s)x \, ds$, for $x \in \overline{\mathbb{R}(A)}$ we may pass to the limit $t \rightarrow \infty$ to obtain a special case of the Calderón reproducing formula (Proposition 10.2.5):

$$x = \lim_{t \rightarrow \infty} x - S(t)x = \int_0^\infty AS(s)x \, ds = \int_0^\infty f(sA)x \frac{ds}{s},$$

for $f(z) = z \exp(-z)$, with improper convergence of the integral. To justify the last step in this computation we use the following fact which, for later reference, we state as a lemma:

Lemma 10.2.8. *Let A be a densely defined sectorial operator and let $f(z) = z \exp(-z)$. Then for all $t > 0$ we have $f(tA) = tAS(t)$.*

Proof. Fixing $\omega(A) < \nu < \frac{1}{2}\pi$ and using the notation as before, we compute

$$\begin{aligned} f(tA) &= \frac{1}{2\pi i} \int_{\partial\Sigma_\nu(\varepsilon)} ze^{-z} R(z, tA) \, dz \\ &= \frac{1}{2\pi i} \int_{\partial\Sigma_\nu(\varepsilon)} tze^{-tz} R(z, A) \, dz \\ &= \frac{1}{2\pi i} \int_{\partial\Sigma_\nu(\varepsilon)} te^{-tz} AR(z, A) \, dz + \frac{1}{2\pi i} \int_{\partial\Sigma_\nu(\varepsilon)} te^{-tz} \, dz \\ &= \frac{1}{2\pi i} A \int_{\partial\Sigma_\nu(\varepsilon)} te^{-tz} R(z, A) \, dz \\ &= tAS(t), \end{aligned}$$

where the last step follows from Theorem G.5.2 after the substitution $z \mapsto -z$. In the computation Cauchy's theorem was used twice, first to see that one integral vanishes, and then to change the path of integration to the one used in Theorem G.5.2. Hille's theorem (Theorem 1.2.4) was used to pull A out of the integral. \square

The technique used in Proposition 10.2.7 is not limited the example treated here, but it will not pursue it any further. Instead, Volume III will include an account of the so-called *extended Dunford calculus*, which systematically develops an idea introduced in (10.14) and allows the treatment of a wider ranges of examples. For now we content ourselves with a variation on this theme which provides a formula for the operators $R(\mu, A)$ in terms of a Dunford integral.

Example 10.2.9. Let A be a sectorial operator and let $\omega(A) < \sigma < \pi$. Then for all $\mu \notin \overline{\Sigma_\sigma}$ for all $x \in \mathcal{R}(A)$ we have

$$\frac{1}{2\pi i} \int_{\partial\Sigma_\sigma} (\mu - z)^{-1} R(z, A)x \, dz = R(\mu, A)x.$$

To see that the integral is absolutely convergent near the origin, we write $x = Ay$ with $y \in \mathcal{D}(A)$ and use that $R(z, A)x = AR(z, A)y = zR(z, A)y - y$ remains bounded near 0. Defining $\Sigma_\nu(\varepsilon)$ as before, from Cauchy's integral theorem and the holomorphy of $z \mapsto R(z, A)x$ we find

$$\frac{1}{2\pi i} \int_{\partial\Sigma_\sigma} \frac{R(z, A)x}{\mu - z} \, dz = \frac{1}{2\pi i} \int_{\partial\Sigma_\sigma(\varepsilon)} \frac{R(z, A)x}{\mu - z} \, dz = R(\mu, A)x.$$

10.2.b The H^∞ -calculus

We now restrict the Dunford calculus to functions in $H^1(\Sigma_\sigma) \cap H^\infty(\Sigma_\sigma)$ and address the problem of extending this restricted calculus to general functions in $H^\infty(\Sigma_\sigma)$. This is a non-trivial problem, if only because $H^1(\Sigma_\sigma) \cap H^\infty(\Sigma_\sigma)$ fails to be dense in $H^\infty(\Sigma_\sigma)$, but more profoundly, because the Dunford integrals become singular for functions in $H^\infty(\Sigma_\sigma)$.

Definition 10.2.10 (Operators with a bounded H^∞ -calculus). *Let A be a sectorial operator on X and let $\omega(A) < \sigma < \pi$. The operator A is said to have a bounded $H^\infty(\Sigma_\sigma)$ -calculus if there exists a constant $C \geq 0$ such that*

$$\|f(A)\| \leq C\|f\|_\infty, \quad f \in H^1(\Sigma_\sigma) \cap H^\infty(\Sigma_\sigma).$$

We define

$$\omega_{H^\infty}(A) := \inf \{ \omega(A) < \sigma < \pi : A \text{ has a bounded } H^\infty(\Sigma_\sigma)\text{-calculus} \}.$$

Suppose now that A is a sectorial operator on X and let $f \in H^\infty(\Sigma_\sigma)$ with $\omega(A) < \sigma < \pi$. By Propositions 10.1.8 and 10.2.3, for the function $\zeta(z) := z(1+z)^{-2}$ we have $\zeta(A) = A(I+A)^{-2}$ and $D(A) \cap R(A) = R(\zeta(A))$. If $x \in D(A) \cap R(A)$, say $x = \zeta(A)y$ with $y \in X$, define

$$\Psi_A(f)x := (f\zeta)(A)y \tag{10.14}$$

using the Dunford calculus of A applied to $f\zeta \in H^1(\Sigma_\sigma)$. To see that this is well defined suppose that $\zeta(A)y = 0$. Then $(I+A)^{-1}[(1+A)^{-1}y - y] = -A(I+A)^{-2}y = 0$, so $(1+A)^{-1}y - y$, and by the resolvent identity this implies $R(z, A)y = z^{-1}y$. Then, with $\omega(A) < \nu < \sigma$,

$$(f\zeta)(A)y = \frac{1}{2\pi i} \int_{\partial\Sigma_\nu} f(z)\zeta(z)R(z, A)y \, dz = \frac{1}{2\pi i} \int_{\partial\Sigma_\nu} \frac{f(z)}{(1+z)^2}y \, dz = 0$$

by Cauchy's theorem.

For $f \in H^1(\Sigma_\sigma) \cap H^\infty(\Sigma_\sigma)$ we have $\Psi_A(f)x = (f\zeta)(A)y = f(A)\zeta(A)y = f(A)x$ by the multiplicativity of the Dunford calculus. This shows that

$$\Psi_A(f) = f(A) \text{ on } D(A) \cap R(A). \tag{10.15}$$

The next proposition shows that whether or not A has a bounded H^∞ -calculus is completely determined by the part of A in $\overline{D(A)} \cap R(A)$.

Proposition 10.2.11. *Let A be a sectorial operator on X and let $\omega(A) < \sigma < \pi$. Let $C > 0$. The following assertions are equivalent:*

- (1) *A has a bounded $H^\infty(\Sigma_\sigma)$ -calculus, i.e., there exists a constant $C \geq 0$ such that for all $f \in H^1(\Sigma_\sigma) \cap H^\infty(\Sigma_\sigma)$,*

$$\|f(A)x\| \leq C\|f\|_\infty\|x\|, \quad x \in X;$$

(2) there exists a constant $C \geq 0$ such that for all $f \in H^1(\Sigma_\sigma) \cap H^\infty(\Sigma_\sigma)$,

$$\|f(A)x\| \leq C\|f\|_\infty\|x\|, \quad x \in \mathbf{D}(A) \cap \mathbf{R}(A);$$

(3) there exists a constant $C \geq 0$ such that for all $f \in H^\infty(\Sigma_\sigma)$,

$$\|\Psi_A(f)x\| \leq C\|f\|_\infty\|x\|, \quad x \in \mathbf{D}(A) \cap \mathbf{R}(A).$$

If $C_{(1)}$, $C_{(2)}$, and $C_{(3)}$ denote the respective best constants, then $C_{(2)} \leq C_{(1)} \leq 2M_{\sigma,A}C_{(3)}$ and $C_{(3)} \leq C_{(2)}/\sin(\sigma \vee \frac{1}{2}\pi)$, and if $\mathbf{D}(A) \cap \mathbf{R}(A)$ is dense, then $C_{(1)} \leq C_{(3)}$.

Observe that if $\omega_{H^\infty}(A) \leq \frac{1}{2}\pi$, then $C_{(3)} \leq C_{(2)}$, and if in addition $\mathbf{D}(A) \cap \mathbf{R}(A)$ is dense then all three constants are equal:

$$C_{(1)} = C_{(2)} = C_{(3)}.$$

Proof. (1) \Rightarrow (2): This holds trivially, with bound $C_{(2)} \leq C_{(1)}$.

(2) \Rightarrow (3): Let $f \in H^\infty(\Sigma_\sigma)$ be given and let ζ_n be the functions of Proposition 10.2.6. Then $\zeta_n f \in H^1(\Sigma_\sigma) \cap H^\infty(\Sigma_\sigma)$. Using the definition (10.14), the convergence property of the Dunford calculus, its multiplicativity, the assumption in (2), and the H^∞ -bound for the ζ_n of Proposition 10.2.6 we obtain, for all $x \in \mathbf{D}(A) \cap \mathbf{R}(A)$, say $x = \zeta(A)y$,

$$\begin{aligned} \|\Psi_A(f)x\| &= \|(f\zeta)(A)y\| = \lim_{n \rightarrow \infty} \|(\zeta_n f \zeta)(A)y\| \\ &= \lim_{n \rightarrow \infty} \|(\zeta_n f)(A)\zeta(A)y\| \leq C \limsup_{n \rightarrow \infty} \|\zeta_n f\|_\infty \|\zeta(A)y\| \\ &\leq \frac{C}{\sin(\sigma \vee \frac{1}{2}\pi)} \|f\|_\infty \|x\|. \end{aligned}$$

This proves that (3) holds, with bound $C_{(3)} \leq C_{(2)}/\sin(\sigma \vee \frac{1}{2}\pi)$.

(3) \Rightarrow (1): For any $f \in H^1(\Sigma_\sigma) \cap H^\infty(\Sigma_\sigma)$ and $x \in X$ we have $\zeta_n(A)x \in \mathbf{D}(A) \cap \mathbf{R}(A)$ and therefore by the convergence property of the Dunford calculus, its multiplicativity, (10.15), and the assumption in (3),

$$\begin{aligned} \|f(A)x\| &= \lim_{n \rightarrow \infty} \|(\zeta_n f)(A)x\| = \lim_{n \rightarrow \infty} \|f(A)\zeta_n(A)x\| \\ &= \lim_{n \rightarrow \infty} \|\Psi_A(f)\zeta_n(A)x\| \leq C\|f\|_\infty \liminf_{n \rightarrow \infty} \|\zeta_n(A)x\|. \end{aligned}$$

If $\mathbf{D}(A) \cap \mathbf{R}(A)$ is dense, for $x \in X$ we have $\lim_{n \rightarrow \infty} \zeta_n(A)x = x$ by the convergence assertion in Proposition 10.2.6; this gives (1) with bound $C_{(1)} \leq C_{(3)}$. In general, all we can say is that $\|\zeta_n(A)x\| \leq 2M_{\sigma,A}C\|x\|$ using the bound on $\zeta_n(A)$ of Proposition 10.2.6; this gives (1) with bound $C_{(1)} \leq 2M_{\sigma,A}C_{(3)}$. \square

Suppose now that A has a bounded $H^\infty(\Sigma_\sigma)$ -calculus. We claim that for all $f \in H^\infty(\Sigma_\sigma)$ and $x \in \overline{\mathbf{D}(A) \cap \mathbf{R}(A)}$ we have $\Psi_A(f)x \in \overline{\mathbf{D}(A) \cap \mathbf{R}(A)}$. To see

this it suffices to consider $x \in \mathbb{D}(A) \cap \mathbb{R}(A)$, say $x = \zeta(A)y$. Then, arguing as in the above proof,

$$\Psi_A(f)x = (f\zeta)(A)y = \lim_{n \rightarrow \infty} (\zeta_n f \zeta)(A)y = \lim_{n \rightarrow \infty} \zeta(A)(\zeta_n f)(A)y$$

with $\zeta(A)(\zeta_n f)(A)y \in \mathbb{R}(\zeta(A)) = \mathbb{D}(A) \cap \mathbb{R}(A)$. This proves the claimed invariance.

We may now define a bounded operator

$$f(A) : \overline{\mathbb{D}(A) \cap \mathbb{R}(A)} \rightarrow \overline{\mathbb{D}(A) \cap \mathbb{R}(A)}$$

by

$$f(A)x := \Psi_A(f)x, \quad x \in \mathbb{D}(A) \cap \mathbb{R}(A).$$

By (10.15), for $f \in H^1(\Sigma_\sigma) \cap H^\infty(\Sigma_\sigma)$ this definition is consistent with the Dunford calculus.

Definition 10.2.12 (The H^∞ -calculus). *Let A be a sectorial operator admitting a bounded $H^\infty(\Sigma_\sigma)$ -calculus. The mapping*

$$f \mapsto f(A)$$

from $H^\infty(\Sigma_\sigma)$ to $\mathcal{L}(\overline{\mathbb{D}(A) \cap \mathbb{R}(A)})$ defined above is called the $H^\infty(\Sigma_\sigma)$ -calculus of A .

By Proposition 10.2.11 we have the norm estimate

$$\|f(A)\|_{\mathcal{L}(\overline{\mathbb{D}(A) \cap \mathbb{R}(A)})} \leq M_{\sigma,A}^\infty \|f\|_\infty, \quad f \in H^\infty(\Sigma_\sigma),$$

where $M_{\sigma,A}^\infty := C_{(3)}$ is the best constant in part (3) of the proposition. This constant will be referred to as the *boundedness constant* of the $H^\infty(\Sigma_\sigma)$ -calculus of A . Note that we have already defined the angle $\omega_{H^\infty}(A)$ of the $H^\infty(\Sigma_\sigma)$ -calculus through Definition 10.2.10; Proposition 10.2.11 shows that we could equivalently have defined this angle using Definition 10.2.12.

The next theorem describes some elementary properties of the H^∞ -calculus.

Theorem 10.2.13. *Let A be a sectorial operator on X with a bounded $H^\infty(\Sigma_\sigma)$ -calculus. The mapping*

$$f \mapsto f(A)$$

from $H^\infty(\Sigma_\sigma)$ to $\mathcal{L}(\overline{\mathbb{D}(A) \cap \mathbb{R}(A)})$ is linear and multiplicative and satisfies

$$\mathbf{1}(A)x = x \quad \text{and} \quad r_\mu(A)x = R(\mu, A)x, \quad x \in \overline{\mathbb{D}(A) \cap \mathbb{R}(A)},$$

where $r_\mu(z) = (\mu - z)^{-1}$ with $\mu \notin \overline{\Sigma_\sigma}$. Furthermore, if the functions $f_n, f \in H^\infty(\Sigma_\sigma)$ are uniformly bounded and satisfy $f_n(z) \rightarrow f(z)$ for all $z \in \Sigma_\sigma$, then

$$\lim_{n \rightarrow \infty} f_n(A)x = f(A)x, \quad x \in \overline{\mathbb{D}(A) \cap \mathbb{R}(A)}. \quad (10.16)$$

Proof. The linearity and multiplicativity are consequences of the convergence property, since it allows us to approximate functions f in $H^\infty(\Sigma_\sigma)$ by functions $f_n = \zeta_n f$ in $H^1(\Sigma_\sigma) \cap H^\infty(\Sigma_\sigma)$, where the functions ζ_n are as in Proposition 10.2.6, and apply the linearity and multiplicativity of the Dunford calculus.

For $x \in D(A) \cap R(A)$ the identity $\mathbf{1}(A)x = x$ is clear from (10.14). Similarly, writing $x = \zeta(A)y$, by (10.14) we have $r_\mu(A)x = (r_\mu \zeta)(A)y$. If we can prove that $(r_\mu \zeta)(A) = AR(\mu, A)(I + A)^{-2}$ the identity $r_\mu(A)x = R(\mu, A)x$ follows from it since $x = \zeta(A)y = A(I + A)^{-2}y$. But this identity follows from Proposition 10.2.3.

Both identities $\mathbf{1}(A)x = x$ and $r_\mu(A)x = R(\mu, A)x$ extend to $x \in \overline{D(A) \cap R(A)}$ by the boundedness of the operators involved. Note that the identity for the resolvent is consistent with the formula in Example 10.2.9.

We now turn to the proof of the convergence property. Using first (10.14), then the convergence property of the Dunford calculus, and then again (10.14), for all $x = \zeta(A)y \in D(A) \cap R(A)$ we obtain

$$\lim_{n \rightarrow \infty} f_n(A)x = \lim_{n \rightarrow \infty} (f_n \zeta)(A)y = (f \zeta)(A)y = f(A)x.$$

This gives the desired convergence on the dense subspace $D(A) \cap R(A)$. Since the operators $f_n(A)$ are uniformly bounded (as the functions f_n are uniformly bounded in $H^\infty(\Sigma_\sigma)$), the result follows from this. \square

Theorem 10.2.14 (Uniqueness of the H^∞ -calculus). *Let A be a sectorial operator on X and let $\omega(A) < \sigma < \pi$. Suppose $\Psi : H^\infty(\Sigma_\sigma) \rightarrow \mathcal{L}(\overline{D(A) \cap R(A)})$ is bounded, linear and multiplicative, satisfies*

$$\Psi r_\mu = R(\mu, A)$$

for all functions $r_\mu(z) = (\mu - z)^{-1}$ with $\mu \notin \overline{\Sigma_\sigma}$, and has the following convergence property:

if f_n, f are functions in $H^\infty(\Sigma_\sigma)$ satisfying $f_n \rightarrow f$ pointwise on Σ_σ and $\sup_n \|f_n\|_\infty < \infty$, then $\Psi(f_n)x \rightarrow \Psi(f)x$ for all $x \in D(A) \cap R(A)$.

Then:

- (1) *A has a bounded $H^\infty(\Sigma_\sigma)$ -calculus;*
- (2) *$\Psi f = f(A)$ as operators in $\mathcal{L}(\overline{D(A) \cap R(A)})$ for all $f \in H^\infty(\Sigma_\sigma)$.*

Proof. First consider a function $f \in H^1(\Sigma_\vartheta) \cap H^\infty(\Sigma_\vartheta)$ with $\sigma < \vartheta < \pi$. We can interpret Cauchy's formula as a Bochner integral in $H^\infty(\Sigma_\sigma)$:

$$f(\cdot) = \frac{1}{2\pi i} \int_{\partial \Sigma_{\sigma'}} \frac{f(\mu)}{\mu - \cdot} d\mu = \int_{\partial \Sigma_{\sigma'}} h(\mu) r_\mu(\cdot) d\mu$$

where $\sigma < \sigma' < \vartheta$, the function $\mu \mapsto r_\mu(\cdot) := \mu(\mu - \cdot)^{-1}$ is uniformly bounded and continuous on $\partial \Sigma_{\sigma'}$ as a function with values in $H^\infty(\Sigma_\sigma)$, and $\mu \mapsto$

$h(\mu) := \frac{1}{2\pi i} f(\mu)/\mu$ is integrable on $\partial\Sigma_{\sigma'}$. The convergence property implies that for any $x \in \mathbb{D}(A) \cap \mathbb{R}(A)$ the operator $\Psi_x : f \mapsto \Psi(f)x$ is closed as an operator from $H^\infty(\Sigma_\sigma)$ to X . Therefore, by Hille's theorem (Theorem 1.2.4) we may pull Ψ_x through the integral defining $\Psi(f)$:

$$\begin{aligned} \Psi(f)x &= \int_{\partial\Sigma_{\sigma'}} h(\mu)\Psi(r_\mu)x \, d\mu = \int_{\partial\Sigma_{\sigma'}} h(\mu)\mu R(\mu, A)x \, d\mu \\ &= \frac{1}{2\pi i} \int_{\partial\Sigma_{\sigma'}} f(\mu)R(\mu, A)x \, d\mu = f(A)x. \end{aligned}$$

If $f \in H^1(\Sigma_\sigma) \cap H^\infty(\Sigma_\sigma)$, consider the function $f_n(z) = f(z^{1-\frac{1}{n}})$ which belongs to $H^1(\Sigma_{\sigma\frac{n-1}{n}}) \cap H^\infty(\Sigma_{\sigma\frac{n-1}{n}})$ for $n \geq 2$. We just saw that $\Psi(f_n) = f_n(A)$. Furthermore $\lim_{n \rightarrow \infty} f_n(z) = f(z)$ and $(f_n)_{n \geq 1}$ is uniformly bounded in $H^\infty(\Sigma_\sigma)$. Therefore, the convergence property implies $\Psi(f_n)x \rightarrow \Psi(f)x$ for all $x \in \mathbb{D}(A) \cap \mathbb{R}(A)$. On the other hand, writing $x = \zeta(A)y \in \mathbb{D}(A) \cap \mathbb{R}(A)$, we find

$$f_n(A)x = f_n(A)\zeta(A)y = (f_n\zeta)(A)y \rightarrow (f\zeta)(A)y = f(A)\zeta(A)y = f(A)x,$$

where we used Theorem 10.2.2. This shows that $f(A) = \Psi(f)$ on $\mathbb{D}(A) \cap \mathbb{R}(A)$, and then on $\overline{\mathbb{D}(A) \cap \mathbb{R}(A)}$ by the boundedness of these operators. As a consequence, for all $x \in \overline{\mathbb{D}(A) \cap \mathbb{R}(A)}$ we obtain

$$\|f(A)x\| = \|\Psi(f)x\| \leq \|\Psi\| \|f\|_\infty \|x\|.$$

By Proposition 10.2.11 this proves (1).

For a general $f \in H^\infty(\Sigma_\sigma)$ there are $f_n \in H^1(\Sigma_\sigma) \cap H^\infty(\Sigma_\sigma)$ with $f_n(\lambda) \rightarrow f(\lambda)$ for $\lambda \in \Sigma_\sigma$ and $\sup_n \|f_n\|_{H^\infty(\Sigma_\sigma)} < \infty$. As both $f \mapsto \Psi f$ and $f \mapsto f(A)$ have the convergence property (the latter in the sense of Theorem 10.2.13), for all $x \in \mathbb{D}(A) \cap \mathbb{R}(A)$ we conclude that $\Psi(f)x = \lim_{n \rightarrow \infty} \Psi(f_n)x = \lim_{n \rightarrow \infty} f_n(A)x = f(A)x$, and by a density argument this extends to $x \in \overline{\mathbb{D}(A) \cap \mathbb{R}(A)}$. This proves (2). \square

Assuming the boundedness of the H^∞ -calculus we can eliminate the growth assumption in the second part of the Calderón reproducing formula (Proposition 10.2.5):

Proposition 10.2.15 (Calderón reproducing formula II). *Let A be a sectorial operator with a bounded $H^\infty(\Sigma_\sigma)$ -calculus, where $\omega(A) < \sigma < \pi$, and suppose that $f \in H^1(\Sigma_\sigma)$ satisfies*

$$\int_0^\infty f(t) \frac{dt}{t} = 1.$$

Then for all $x \in \overline{\mathbb{D}(A) \cap \mathbb{R}(A)}$ we have

$$\int_0^\infty f(tA)x \frac{dt}{t} = x,$$

the integral being convergent as an improper integral in X . Moreover,

$$\sup_{0 < a \leq b < \infty} \left\| \int_a^b f(tA)x \frac{dt}{t} \right\| \leq M_{\sigma,A}^\infty \|f\|_{H^1(\Sigma_\sigma)} \|x\|.$$

Proof. In the first part of Proposition 10.2.5 we have already seen that the reproducing identity holds for $x \in D(A) \cap R(A)$. Moreover, as in the proof of the second part of the proposition, the identity extends to $\overline{D(A) \cap R(A)}$ if we can prove the uniform boundedness of the operators $x \mapsto \varphi_{a,b}(A)x := \int_a^b f(tA)x \frac{dt}{t}$, $0 < a \leq b < \infty$, on this space. But in view of

$$\|\varphi_{a,b}\|_{H^\infty(\Sigma_\sigma)} = \sup_{z \in \Sigma_\sigma} |\varphi_{a,b}(z)| \leq \sup_{z \in \Sigma_\sigma} \int_0^\infty |f(tz)| \frac{dt}{t} = \|f\|_{H^1(\Sigma_\sigma)},$$

this follows from the boundedness of the $H^\infty(\Sigma_\sigma)$ -calculus. □

We conclude this section with two constructions of new sectorial operators from old. The first describes a simple scaling property that will be frequently used without comment. For $f : \Sigma_\vartheta \rightarrow \mathbb{C}$ and $\mu \in \mathbb{C}$ put

$$f_\mu(z) := f(\mu z), \quad z \in \Sigma_\sigma.$$

Lemma 10.2.16. *Let A be a sectorial operator and let $\omega(A) < \sigma < \vartheta < \pi$ and $\mu \in \Sigma_{\vartheta-\sigma}$. If $f \in H^1(\Sigma_\vartheta)$, then:*

- (1) μA is sectorial with $\omega(\mu A) < \vartheta$;
- (2) $f_\mu \in H^1(\Sigma_\sigma)$ and $f_\mu(A) = f(\mu A)$;
- (3) the mapping $\mu \mapsto f(\mu A)$ is holomorphic from $\Sigma_{\sigma-\vartheta}$ to $\mathcal{L}(\overline{D(A) \cap R(A)})$.

Moreover, if A admits a bounded $H^\infty(\Sigma_\sigma)$ -calculus and $f \in H^\infty(\Sigma_\vartheta)$, then:

- (1)' μA admits a bounded H^∞ -calculus with $\omega_{H^\infty}(\mu A) < \vartheta$;
- (2)' $f_\mu \in H^\infty(\Sigma_\sigma)$ and $f_\mu(A) = f(\mu A)$;
- (3)' the mapping $\mu \mapsto f(\mu A)$ is holomorphic from $\Sigma_{\sigma-\vartheta}$ to $\mathcal{L}(\overline{D(A) \cap R(A)})$.

Proof. The first two assertions are obvious. For the third, let $\omega(A) < \nu < \sigma$. Let D be a closed disk contained in $\Sigma_{\vartheta-\sigma}$. By Fubini's theorem and Cauchy's theorem, we obtain

$$\int_{\partial D} f(\mu A) d\mu = \frac{1}{2\pi i} \int_{\partial \Sigma_\nu} \int_{\partial D} f(\mu z) R(z, A) d\mu dz = 0.$$

Now the holomorphy of $\mu \mapsto f(\mu A)$ follows from Morera's theorem.

The proofs of (1)'–(3)' are similar. For (3)' let ζ_n be the functions considered in Proposition 10.2.6. By (3), $\mu \mapsto f(\mu A)\zeta_n(A)$ is holomorphic and thus

$$\int_{\partial D} f(\mu A)\zeta_n(A)x d\mu = 0, \quad x \in \overline{D(A) \cap R(A)}.$$

By the dominated convergence theorem and Proposition 10.2.6,

$$\int_{\partial D} f(\mu A)x \, d\mu = 0, \quad x \in \overline{D(A) \cap R(A)}.$$

Therefore, the holomorphy of $\mu \mapsto f(\mu A)x$ follows from Morera’s theorem. Inspection of the proof of Proposition B.3.1 shows that $\mu \mapsto f(\mu A) \in \mathcal{L}(\overline{D(A) \cap R(A)})$ is continuous in the uniform operator topology. Therefore, Corollary B.3.3 implies that $\mu \mapsto f(\mu A)$ is holomorphic as an operator-valued function. \square

The second construction formalises the idea of “substituting” A into an integral expression.

Lemma 10.2.17. *Let A be a sectorial operator on a Banach space X and let $\omega(A) < \sigma < \pi$. Assume either one of the following:*

- (a) $p = 1$;
- (b) $p = \infty$, A has a bounded H^∞ -calculus, and $\omega_{H^\infty}(A) < \sigma < \pi$.

Let (S, \mathcal{A}, μ) be a σ -finite measure space. Suppose that $f : S \times \Sigma_\sigma \rightarrow \mathbb{C}$ is a measurable function with the following properties:

- (i) $z \mapsto f(s, z)$ belongs to $H^p(\Sigma_\sigma)$ for all $s \in S$;
- (ii) $\sup_{|\nu| < \sigma} \left\| t \mapsto \int_S |f(s, e^{i\nu} t)| \, d\mu(s) \right\|_{L^p(\mathbb{R}_+, \frac{dt}{t})} < \infty$.

Then the function $g(z) = \int_S f(s, z) \, d\mu(s)$ belongs to $H^p(\Sigma_\sigma)$ and

$$g(A)x = \int_S f(s, A)x \, d\mu(s), \quad \begin{cases} x \in X & \text{in case (a)} \\ x \in \overline{D(A) \cap R(A)} & \text{in case (b)} \end{cases}.$$

Proof. (a): Let D be a closed disk contained in Σ_σ . Applying first Fubini’s theorem and then Cauchy’s theorem we see that

$$\int_{\partial D} g(\lambda) \, d\lambda = \int_S \left(\int_{\partial D} f(s, \lambda) \, d\lambda \right) d\mu(s) = 0.$$

Hence Morera’s theorem implies that g is holomorphic on Σ_σ . Also,

$$\sup_{|\nu| < \sigma} \|g(e^{i\nu} \cdot)\|_{L^p(\mathbb{R}_+, \frac{dt}{t})} \leq \sup_{|\nu| < \sigma} \left\| t \mapsto \int_S |f(s, e^{i\nu} t)| \, d\mu(s) \right\|_{L^p(\mathbb{R}_+, \frac{dt}{t})} < \infty,$$

and thus $g \in H^p(\Sigma_\sigma)$. By Fubini’s theorem,

$$\begin{aligned} g(A)x &= \frac{1}{2\pi i} \int_{\partial \Sigma_\nu} g(\lambda)R(\lambda, A)x \, d\lambda \\ &= \int_S \left(\frac{1}{2\pi i} \int_{\partial \Sigma_\nu} f(s, \lambda)R(\lambda, A)x \, d\lambda \right) d\mu(s) = \int_S f(s, A)x \, d\mu(s) \end{aligned}$$

for all $x \in X$.

(b): Let ζ_n be the functions considered in Proposition 10.2.6 and put

$$f_n(s, z) := \zeta_n(z)f(s, z), \quad g(z) := \int_S f_n(s, z) d\mu(s).$$

Then $f_n \in H^1(\Sigma_\sigma)$ and hence, by the result of (a),

$$g_n(A)x = \int_S f_n(s, A)x d\mu(s), \quad x \in X.$$

Letting $n \rightarrow \infty$, the required identity follows from Theorem 10.2.13 and the dominated convergence theorem. \square

Proposition 10.2.18 (Restrictions). *Let $Y \subseteq X$ be a closed subspace which is invariant under $R(\lambda, A)$ for all $\lambda \in \varrho(A)$. Then the part A_Y of A to Y has a bounded H^∞ -calculus on X , then A_Y has a bounded H^∞ -calculus on Y with $\omega_{H^\infty}(A_Y) \leq \omega_{H^\infty}(A)$, and for all $f \in H^\infty(\Sigma_\sigma)$ with $\omega_{H^\infty}(A) < \sigma < \pi$ we have*

$$f(A_Y)x = f(A)x, \quad x \in Y.$$

Proof. For $\omega(A) < \sigma < \pi$ and $\lambda \in \overline{\mathbb{C}\Sigma_\sigma}$, the restricted resolvent operator $R(\lambda, A)|_Y$ is a two-sided inverse of $\lambda - A_Y$, and therefore $\lambda \in \varrho(A_Y)$ and $R(\lambda, A_Y) = R(\lambda, A)|_Y$. From this, the rest trivially follows. \square

It suffices to assume the invariance of Y under the resolvent for one point $\lambda_0 \in \overline{\mathbb{C}\Sigma_\sigma}$. Indeed, for $|\lambda - \lambda_0| < \delta$ with $\delta > 0$ small enough, by the Neumann series argument of Lemma G.1.1 (or repeated use of the resolvent identity) we have $\lambda \in \varrho(A)$ and

$$R(\lambda, A) = \sum_{n=0}^{\infty} (\lambda - \lambda_0)^n R(\lambda_0, A)^{n+1}.$$

This implies that Y is invariant under $R(\lambda, A)$. The set of all $\lambda \in \varrho(A)$ for which the resolvent leaves Y invariant is therefore open, and evidently it is closed as well. It therefore includes the connected component of $\varrho(A)$ containing λ_0 , which contains $\overline{\mathbb{C}\Sigma_\sigma}$; the latter is all that was used in the proof of the proposition.

Next we will consider the functional calculus for the adjoint operator A^* . A brief introduction to the theory of adjoint operators can be found in Section G.1. If A is a densely defined sectorial operator, then its adjoint A^* is sectorial as well and $\omega(A) = \omega(A^*)$; this is immediate from the fact that $R(\lambda, A^*) = R(\lambda, A)^*$ for all $\lambda \in \varrho(A^*) = \varrho(A)$. Therefore, if $\omega(A) < \nu < \sigma < \pi$, then for functions $f \in H^1(\Sigma_\sigma)$ the operators $f(A^*)$ defined by Dunford calculus,

$$f(A^*) = \frac{1}{2\pi i} \int_{\partial\Sigma_\nu} f(z)R(z, A^*) dz,$$

are well defined and satisfy $f(A^*) = f(A)^*$.

Lemma 10.2.19. *Let A be a densely defined sectorial operator and let $\omega(A) < \sigma < \pi$. Then for all $x \in \overline{D(A) \cap R(A)} = \overline{R(A)}$ and $x^* \in \overline{D(A^*) \cap R(A^*)}$, we have*

$$\begin{aligned} \frac{1}{2M_{A,\sigma}} \|x\| &\leq \sup \{ |\langle x, y^* \rangle| : y^* \in D(A^*) \cap R(A^*), \|y^*\| \leq 1 \} \leq \|x\| \\ \frac{1}{2M_{A,\sigma}} \|x^*\| &\leq \sup \{ |\langle y, x^* \rangle| : y \in D(A) \cap R(A), \|y\| \leq 1 \} \leq \|x^*\|. \end{aligned}$$

Proof. It suffices to prove the left-hand estimates. Fix $x \in \overline{D(A) \cap R(A)}$ and put

$$\|x\| := \sup \{ |\langle x, y^* \rangle| : y^* \in D(A^*) \cap R(A^*), \|y^*\| \leq 1 \}.$$

Choose $x^* \in X^*$ such that $|\langle x, x^* \rangle| = \|x\|$. As in Proposition 10.2.6 we have $\zeta_n(A)x \rightarrow x$ as $n \rightarrow \infty$, $y_n^* := \zeta_n(A^*)x^* \in D(A^*) \cap R(A^*)$, and $\|y_n^*\| \leq 2M_{\sigma,A}\|x^*\|$. Then

$$\|x\| = |\langle x, x^* \rangle| = \lim_{n \rightarrow \infty} |\langle \zeta_n(A)x, x^* \rangle| = \lim_{n \rightarrow \infty} |\langle x, y_n^* \rangle| \leq 2M_{\sigma,A}\|x^*\|.$$

This proves the first assertion. The proof of the second is similar. □

Proposition 10.2.20 (Adjoints). *Let A be a densely defined sectorial operator with a bounded H^∞ -calculus. Then A^* has a bounded H^∞ -calculus, we have $\omega_{H^\infty}(A) = \omega_{H^\infty}(A^*)$, and for all $f \in H^\infty(\Sigma_\sigma)$ with $\omega_{H^\infty}(A) < \sigma < \pi$ we have*

$$\langle x, f(A^*)x^* \rangle = \langle f(A)x, x^* \rangle, \quad x \in \overline{D(A) \cap R(A)}, \quad x^* \in \overline{D(A^*) \cap R(A^*)}.$$

Proof. For $f \in H^1(\Sigma_\sigma) \cap H^\infty(\Sigma_\sigma)$, the identity $f(A)^* = f(A^*)$ implies $\langle x, f(A^*)x^* \rangle = \langle f(A)x, x^* \rangle$ for all $x \in X$ and $x^* \in X^*$ and therefore

$$|\langle x, f(A^*)x^* \rangle| \leq M_{\sigma,A}^\infty \|f\|_{H^\infty(\Sigma_\sigma)} \|x\| \|x^*\|.$$

Taking the supremum over all $x \in X$ with $\|x\| \leq 1$, we see that A^* has a bounded $H^\infty(\Sigma_\sigma)$ -calculus with angle $\omega_{H^\infty}(A^*) \leq \omega_{H^\infty}(A)$.

Now let $f \in H^\infty(\Sigma_\sigma)$ and let ζ_n be as in Proposition 10.2.6. Then by the convergence property of Theorem 10.2.13, for all $x \in \overline{D(A) \cap R(A)}$ and $x^* \in \overline{D(A^*) \cap R(A^*)}$ we obtain

$$\langle x, f(A^*)x^* \rangle = \lim_{n \rightarrow \infty} \langle x, (\zeta_n f)(A^*)x^* \rangle = \lim_{n \rightarrow \infty} \langle (\zeta_n f)(A)x, x^* \rangle = \langle f(A)x, x^* \rangle,$$

using that $\zeta_n f \in H^1(\Sigma_\sigma) \cap H^\infty(\Sigma_\sigma)$ in the middle step, so that the duality identity of the first part of the proof applies.

To finish the proof it remains to be shown that the converse inequality $\omega_{H^\infty}(A) \leq \omega_{H^\infty}(A^*)$ holds. But this follows by applying what has been said above to the part of A^* in $\overline{D(A^*) \cap R(A^*)}$ and using the lemma to embed X isomorphically onto a closed subspace of the dual of $\overline{D(A^*) \cap R(A^*)}$. □

10.2.c First examples

We will now present some first examples of operators having a bounded H^∞ -calculus. They only serve to give a first flavour of the subject, and most of them admit far-reaching generalisations, some of which are collected in the Notes at the end of the chapter.

Proposition 10.2.21 (Bounded operators). *Let A be a bounded operator whose spectrum $\sigma(A)$ avoids the negative axis $(-\infty, 0]$. For any $0 < \sigma < \pi$ such that $\sigma(A) \subseteq \Sigma_\sigma$, A has a bounded $H^\infty(\Sigma_\sigma)$ -calculus.*

Proof. We define the calculus by the Dunford integral

$$f(A) = \frac{1}{2\pi i} \int_\Gamma f(z)R(z, A) dz,$$

where Γ is a simple closed Jordan curve contained in Σ_σ containing the spectrum of A in its interior, oriented in the counter-clockwise direction. If $f \in H^1(\Sigma_\sigma) \cap H^\infty(\Sigma_\sigma)$, then by Cauchy's theorem the contour Γ may be changed to $\partial\Sigma_\sigma$, and therefore the above definition agrees with the Dunford calculus of A as a sectorial operator. \square

The condition $0 \notin \sigma(A) \cap (-\infty, 0]$ cannot be omitted, as can be seen from Corollary 10.2.29.

Proposition 10.2.22 (Pointwise multipliers). *Let (S, \mathcal{A}, μ) be a measure space, let $0 < \sigma < \pi$, and let $m : S \rightarrow \mathbb{C}$ be a measurable function taking values in Σ_σ μ -almost surely. Let $1 \leq p < \infty$ and consider the pointwise multiplication operator A_m on $L^p(S)$ given by*

$$M_m\phi(s) := m(s)\phi(s), \quad s \in S,$$

with its natural domain $D(M_m) = \{\phi \in L^p(S) : m\phi \in L^p(S)\}$. Then A_m is a sectorial operator with a bounded $H^\infty(\Sigma_\sigma)$ -calculus on $L^p(S)$.

Proof. For $z \notin \overline{\Sigma_\sigma}$ we have $z \in \rho(A_m)$ and $R(z, A_m)\phi(s) = (z - m(s))^{-1}f(s)$. Fix $\omega < \nu < \sigma$. For functions $f \in H^1(\Sigma_\sigma) \cap H^\infty(\Sigma_\sigma)$ and $\phi \in L^p(S)$ we then have

$$f(A_m)\phi(s) = \frac{1}{2\pi i} \int_{\partial\Sigma_\nu} \frac{f(z)}{z - m(s)} \phi(s) dz = f(m(s))\phi(s)$$

for μ -almost all $s \in S$. Clearly, $\|f(A_m)\| \leq \|f\|_\infty$ and therefore A_m has a bounded $H^\infty(\Sigma_\sigma)$ -calculus on $L^p(S)$, with constant $M_{\sigma, A_m}^\infty \leq 1$. \square

We continue with two basic Hilbertian examples.

Proposition 10.2.23 (Positive self-adjoint operators). *Let A be a densely defined self-adjoint operator on a complex Hilbert space H which is positive in the sense that the spectrum $\sigma(A)$ is contained in the positive half-line $[0, \infty)$. Then A has a bounded H^∞ -calculus of angle 0.*

Proof. By Proposition 10.2.11 it suffices to consider the part of A in $H_0 := \overline{D(A)} \cap R(A)$. Considered as an operator on that space, A is positive, self-adjoint and injective by Proposition 10.1.8.

By the spectral theorem for self-adjoint operators, A is unitarily equivalent to a multiplication operator. More precisely, there exists a measure space (S, \mathcal{A}, μ) and measurable function $m : S \rightarrow [0, \infty)$ and a invertible operator $U \in \mathcal{L}(H_0, L^2(S))$ such that

$$A = U^{-1}A_m U,$$

where A_m is as in Proposition 10.2.22. Since A is injective, A_m is injective and hence $\{s \in S : m(s) = 0\}$ has measure zero. Since the property of having a bounded H^∞ -calculus is inherited under similarity transforms, from Proposition 10.2.22 we conclude that A is sectorial and has a bounded H^∞ -calculus with $\omega_{H^\infty}(A) = 0$. \square

Theorem 10.2.24 (Contraction semigroups on Hilbert spaces). *Suppose that $-A$ generates a C_0 -contraction semigroup on a Hilbert space H . Then A has a bounded $H^\infty(\Sigma_\sigma)$ -functional calculus for all $\frac{1}{2}\pi < \sigma < \pi$ and*

$$\|f(A)\| \leq \|f\|_{H^\infty(\Sigma_{\frac{1}{2}\pi})}, \quad f \in H^1(\Sigma_\sigma) \cap H^\infty(\Sigma_\sigma).$$

In particular, this calculus has angle $\omega_{H^\infty}(A) \leq \frac{1}{2}\pi$ and constants $M_{\sigma,A}^\infty \leq 1$ for all $\frac{1}{2}\pi < \sigma < \pi$.

In Theorem 10.4.21 it will be shown that for any sectorial operator A with a bounded H^∞ -calculus on a Hilbert space one has equality $\omega_{H^\infty}(A) = \omega(A)$. Moreover, a characterisation of those operators satisfying $\omega_{H^\infty}(A) < \frac{1}{2}\pi$ will be given in Theorem 10.4.22.

Proof. We prove the theorem in three steps.

Step 1 – First we assume in addition that A is a *bounded* operator and that $-A + c$ generates a C_0 -contraction semigroup on H for some fixed $c > 0$, or equivalently (see Corollary G.4.5) that $\Re(Ax|x) \geq c\|x\|^2$ for all $x \in H$. Observe that $\{\lambda \in \mathbb{C} : \Re(\lambda) > -c\} \subseteq \rho(A)$ and since $\sigma(A)$ is compact, A is sectorial of angle $\frac{1}{2}\pi - \delta$ for some $\delta > 0$. Next note that

$$((A + A^*)x|x) = (Ax|x) + \overline{(Ax|x)} = 2\Re(Ax|x) \geq 2c\|x\|^2,$$

so that $A + A^*$ is self-adjoint and positive.

Fix $\frac{1}{2}\pi < \sigma < \pi$ and let $f \in H^1(\Sigma_\sigma)$. Then $\lambda \mapsto f(\lambda)(A^* + \lambda)^{-1}$ is holomorphic in $\overline{\mathbb{C}\Sigma_{\frac{1}{2}\pi - \delta}}$. By Cauchy’s theorem applied to the boundary of the semi-annulus $\{r \leq |z| \leq R\} \cap \{\Re z \geq 0\}$, upon letting $r \downarrow 0$ and $R \rightarrow \infty$ and using Lemma H.1.4, we obtain

$$\int_{i\mathbb{R}} f(\lambda)(A^* + \lambda)^{-1} d\lambda = 0.$$

Hence,

$$\begin{aligned} f(A) &= \frac{1}{2\pi i} \int_{i\mathbb{R}} f(\lambda) R(\lambda, A) \, d\lambda \\ &= -\frac{1}{2\pi i} \int_{i\mathbb{R}} f(\lambda) [(A - \lambda)^{-1} + (A^* + \lambda)^{-1}] \, d\lambda \\ &= \frac{1}{2\pi} \int_{\mathbb{R}} f(it) (A^* + it)^{-1} (A^* + A) (A - it)^{-1} \, dt. \end{aligned}$$

Therefore, for all $x, y \in H$,

$$\begin{aligned} (f(A)x|y) & \tag{10.17} \\ &= \frac{1}{2\pi} \int_{\mathbb{R}} f(it) \left((A^* + A)^{1/2} (A - it)^{-1} x \mid (A^* + A)^{1/2} (A - it)^{-1} y \right) \, dt. \end{aligned}$$

So far we took $f \in H^1(\Sigma_\sigma)$. Taking $f = \zeta_n$ as in Proposition 10.2.6 and letting $n \rightarrow \infty$, and taking $x = y$ in (10.17), for all $x \in H$ (remember that in this step A is bounded and invertible) we obtain

$$\|x\|^2 = \frac{1}{2\pi} \int_{\mathbb{R}} \|(A^* + A)^{1/2} (A - it)^{-1} x\|^2 \, dt. \tag{10.18}$$

It now follows from (10.17) and (10.18) that

$$\begin{aligned} |(f(A)x, y)| &\leq \|f\|_{H^\infty(\Sigma_{\frac{1}{2}\pi})} \left(\frac{1}{2\pi} \int_{\mathbb{R}} \|(A^* + A)^{1/2} (A - it)^{-1} x\|^2 \, dt \right)^{1/2} \\ &\quad \times \left(\frac{1}{2\pi} \int_{\mathbb{R}} \|(A^* + A)^{1/2} (A - it)^{-1} y\|^2 \, dt \right)^{1/2} \\ &= \|f\|_{H^\infty(\Sigma_{\frac{1}{2}\pi})} \|x\| \|y\|. \end{aligned}$$

Step 2 – We reduce the general case to the case considered in Step 1. The assumptions of the theorem imply that A is sectorial of angle $\frac{1}{2}\pi$.

For any $\varepsilon > 0$ define a bounded operator

$$A_\varepsilon := ((A + \varepsilon)^{-1} + \varepsilon)^{-1} = \varepsilon^{-1} - \varepsilon^{-2}(\varepsilon + \varepsilon^{-1} + A)^{-1}.$$

Then $\|(\varepsilon + \varepsilon^{-1} + A)^{-1}\| \leq (\varepsilon + \varepsilon^{-1})^{-1} = \varepsilon(\varepsilon^2 + 1)^{-1}$ and therefore

$$\|e^{-tA_\varepsilon}\| \leq e^{-\varepsilon^{-1}t} e^{\varepsilon^{-2}t\|(\varepsilon + \varepsilon^{-1} + A)^{-1}\|} \leq e^{-\varepsilon(1 + \varepsilon^2)^{-1}t}.$$

Hence A_ε satisfies the assumption of Step 1 and in particular A_ε is sectorial of angle $\frac{1}{2}\pi$ with uniform estimates in ε . Moreover, for all $\Re\lambda < 0$,

$$\begin{aligned} \|R(\lambda, A) - R(\lambda, A_\varepsilon)x\| &= \|R(\lambda, A_\varepsilon)(A - A_\varepsilon)R(\lambda, A)x\| \\ &\leq \frac{1}{\Re(\lambda)} \|(A - A_\varepsilon)R(\lambda, A)x\| \end{aligned}$$

The right-hand side tends to zero as $\varepsilon \downarrow 0$ since for all $x \in D(A)$,

$$\|Ax - A_\varepsilon x\| \leq \|Ax - \varepsilon^{-1}(\varepsilon + \varepsilon^{-1} + A)^{-1}Ax\| + \|(\varepsilon + \varepsilon^{-1} + A)^{-1}x\| \rightarrow 0$$

by Proposition 10.1.7 and the sectoriality of A . Therefore, for $f \in H^1(\Sigma_\sigma) \cap H^\infty(\Sigma_\sigma)$ and $\frac{1}{2}\pi < \nu < \sigma$, by dominated convergence we obtain

$$\begin{aligned} f(A)x &= \int_{\partial\Sigma_\omega} f(\lambda)R(\lambda, A)x \, d\lambda \\ &= \lim_{\varepsilon \downarrow 0} \int_{\partial\Sigma_\omega} f(\lambda)R(\lambda, A_\varepsilon)x \, d\lambda \\ &= \lim_{\varepsilon \downarrow 0} \int_{i\mathbb{R}} f(\lambda)R(\lambda, A_\varepsilon)x \, d\lambda = \lim_{\varepsilon \downarrow 0} f(A_\varepsilon)x. \end{aligned}$$

By Step 1,

$$\|f(A_\varepsilon)x\| \leq \|f\|_{H^\infty(\Sigma_{\frac{1}{2}\pi})}\|x\|, \quad f \in H^1(\Sigma_\sigma) \cap H^\infty(\Sigma_\sigma),$$

and the estimate $\|f(A)x\| \leq \|f\|_{H^\infty(\Sigma_{\frac{1}{2}\pi})}\|x\|$ follows by letting $\varepsilon \downarrow 0$. This completes the proof. \square

In the setting of general Banach spaces, an essential feature in the proof of Theorem 10.2.24 persists, namely the norm equivalence given in (10.18) in terms of A . It will be shown in Section 10.4.a that, modulo some assumptions that are automatically satisfied in the Hilbertian case, such norm equivalences resurface as square function estimates and characterise sectorial operators with a bounded H^∞ -calculus.

Let us also point out that an analogue of Theorem 10.2.24 holds for positive C_0 -contraction semigroups on L^p -spaces when $1 < p < \infty$ (see Theorem 10.7.12).

Recall from Example 10.1.5 that the operator $A = -\Delta$ is densely defined, injective and sectorial of angle $\omega(A) = 0$.

Theorem 10.2.25 (Laplacian on $L^p(\mathbb{R}^d; X)$). *Let X be a UMD Banach space and $1 < p < \infty$. The Laplace operator $-\Delta$ has a bounded H^∞ -calculus on $L^p(\mathbb{R}^d; X)$ of angle 0.*

The UMD assumption is necessary, as a consequence of Corollary 10.5.2 below.

Proof. Define, for $f \in H^\infty(\Sigma_\sigma)$ with $0 < \sigma < \pi$,

$$\Psi(f)\phi := \mathcal{F}^{-1}[f(4\pi^2|\cdot|^2)\widehat{\phi}(\cdot)], \quad \phi \in \mathcal{S}(\mathbb{R}^d; X).$$

To prove the boundedness of $f(A)$ we check the conditions of the Mihlin multiplier theorem (Theorem 5.5.10). For this we have to bound, for multi-indices $\alpha \leq (1, \dots, 1)$,

$$|t|^{|\alpha|} D^\alpha f(|t|^2) = |t|^{2|\alpha|} 2^{|\alpha|} t^\alpha f^{(|\alpha|)}(|t|^2) = \left(\frac{2t}{|t|}\right)^\alpha (|t|^2)^{|\alpha|} f^{(|\alpha|)}(|t|^2).$$

But for integers $k \geq 1$, the boundedness of $t^k f^{(k)}(t)$ for $t > 0$ follows from the Cauchy formula since $f \in H^\infty(\Sigma_\sigma)$ for $\sigma > 0$. Indeed, for $\sigma' \in (0, \sigma)$, we have

$$|t^k f^{(k)}(t)| \leq \frac{1}{2\pi} \int_{\Gamma_{\sigma'}} \frac{|t|^k |f(z)|}{|z-t|^{k+1}} |dz| \leq \frac{C}{2\pi} \int_{\Gamma_{\sigma'}} \frac{1}{|z-1|^{k+1}} |dz| < \infty.$$

Hence $\Psi(f)$ defines a bounded operator on $L^p(\mathbb{R}^d; X)$. One can check directly that the mapping $f \mapsto \Psi(f)$ satisfies the assumptions of Theorem 10.2.14. For instance, the multiplicativity follows from the properties of the convolution product, and the convergence property follows from the dominated convergence theorem since $\widehat{\phi} \in L^1(\mathbb{R}^d; X)$ and $\mathcal{S}(\mathbb{R}^d; X)$ is dense in $L^p(\mathbb{R}^d; X)$. By Theorem 10.2.14, $f \mapsto \Psi(f)$ must be the bounded $H^\infty(\Sigma_\sigma)$ -calculus of $-\Delta$. Since $\sigma > 0$ was arbitrary, the result follows. \square

In the same way one proves that the first derivative $Af = f'$ on $L^p(\mathbb{R}; X)$ is sectorial and has a bounded $H^\infty(\Sigma_\omega)$ -calculus with $\omega(A) = \omega_{H^\infty}(A) = \frac{1}{2}\pi$ if $1 < p < \infty$ and X is a UMD space. Indeed, for $f \in H^\infty(\Sigma_\sigma)$ with $\sigma \in (\frac{1}{2}\pi, \pi)$ define

$$\Psi(f)\phi := \mathcal{F}^{-1}[f(2\pi i \cdot) \widehat{\phi}(\cdot)], \quad \phi \in \mathcal{S}(\mathbb{R}^d; X).$$

The boundedness of $\Psi(A)$ again follows from the Mihlin multiplier theorem. In the same way as in the previous example one checks that $f \mapsto \Psi(f)$ defines a bounded $H^\infty(\Sigma_\sigma)$ -calculus for A .

Remark 10.2.26. Let $\sigma \in (0, \pi)$ and $1 < p < \infty$. The UMD property is not only sufficient for the boundedness of the $H^\infty(\Sigma_\sigma)$ functional calculus of $-\Delta$ on $L^p(\mathbb{R}^d; X)$, but also necessary. As a consequence the UMD property of X can be characterised in terms of the spectral theory of the operator $-\Delta$ on $L^p(\mathbb{R}^d; X)$. This point will be taken up in Section 10.5.

Counterexamples

In this section we discuss a class of diagonal operators modelled on a Schauder basis. It will be convenient later on to label the bases with index set \mathbb{Z} . From Chapter 4 we recall that a sequence $(x_n)_{n \in \mathbb{Z}}$ in a Banach space X is called a *Schauder basis* if for each $x \in X$ there exists a unique sequence of scalars $(\alpha_n)_{n \in \mathbb{Z}}$ such that $x = \sum_{n \in \mathbb{Z}} \alpha_n x_n$, the summation being understood in the improper sense, i.e., $x = \lim_{m, n \rightarrow \infty} \sum_{k=-m}^n \alpha_k x_k$ (see Definition 4.1.14).

As a side-remark on double-sided improper convergence, observe that the limit $\lim_{m, n \rightarrow \infty} \sum_{k=-m}^n \alpha_k x_k$ exists if and only if both $\lim_{n \rightarrow \infty} \sum_{k=1}^n \alpha_k x_k$ and $\lim_{m \rightarrow \infty} \sum_{k=-m}^0 \alpha_k x_k$ exist. The ‘if’ part is clear. To prove the ‘only if’ part, let $x = \lim_{m, n \rightarrow \infty} \sum_{k=-m}^n \alpha_k x_k$ be the limit. Given an $\varepsilon > 0$ we choose N so large that

$$\left\| x - \sum_{k=-m}^n \alpha_k x_k \right\| < \varepsilon$$

for all $m, n \geq N$. Then, for $m, n \geq N$,

$$\left\| \sum_{k=1}^n \alpha_k x_k - \sum_{k=1}^m \alpha_k x_k \right\| = \left\| \sum_{k=-N}^n \alpha_k x_k - \sum_{k=-N}^m \alpha_k x_k \right\| < 2\varepsilon.$$

Therefore the series $\sum_{k=1}^\infty \alpha_k x_k$ converges. In the same way one sees that $\sum_{k=-\infty}^0 \alpha_k x_k$ converges.

Now let $(x_n)_{n \in \mathbb{Z}}$ be a Schauder basis. By an application of the closed graph theorem, the coordinate projections

$$x_j^* : \sum_{n \in \mathbb{Z}} \alpha_n x_n \mapsto \alpha_j$$

are bounded. Therefore, for $M, N \in \mathbb{Z}$ with $M \leq N$ we can define the projections $P_{M,N} \in \mathcal{L}(X)$ by

$$P_{M,N} : \sum_{n \in \mathbb{Z}} \alpha_n x_n \mapsto \sum_{n=M}^N \alpha_n x_n.$$

By the uniform boundedness principle, we have

$$C := \sup_{M \leq N} \|P_{M,N}\| < \infty.$$

Throughout this subsection the constant C will have the above meaning.

We start with a multiplier lemma of Marcinkiewicz type.

Lemma 10.2.27. *Let X be a Banach space with a Schauder basis $(x_n)_{n \in \mathbb{Z}}$. Assume that $(\lambda_n)_{n \in \mathbb{Z}}$ is a sequence of scalars such that*

$$L := \sup_{n \in \mathbb{Z}} |\lambda_n| + \sum_{n \in \mathbb{Z}} |\lambda_{n+1} - \lambda_n| < \infty.$$

If $x = \sum_{n \in \mathbb{Z}} c_n x_n$, then $\sum_{n \in \mathbb{Z}} \lambda_n c_n x_n$ converges in X and

$$\left\| \sum_{n \in \mathbb{Z}} \lambda_n c_n x_n \right\| \leq 2CL \|x\|.$$

Proof. As explained before the lemma it suffices to consider bases over the index sets \mathbb{Z}_+ and \mathbb{Z}_- separately. By relabelling we may assume that $c_j = 0$ for $j \leq 0$. Let $s_n = \sum_{j=1}^n c_j x_j$ and $t_n = \sum_{j=1}^n \lambda_j c_j x_j$ for $n \geq 1$. A summation by parts gives

$$t_n = \lambda_{n+1} s_n - \sum_{j=1}^n (\lambda_{j+1} - \lambda_j) s_j.$$

The boundedness of the partial sum projections implies $\|s_j\| \leq C\|x\|$ and thus

$$\|t_n\| \leq |\lambda_{n+1}|\|s_n\| + \sum_{j=1}^n |\lambda_{j+1} - \lambda_j|\|s_j\| \leq CL\|x\|.$$

Therefore, the required estimate follows as soon as we have shown that $(t_n)_{n \geq 1}$ is convergent. Applying the above estimate with $s_n - s_m$ (where $1 \leq m \leq n$) instead of x (and thus $c_1 = \dots = c_m = 0$), we obtain $\|t_n - t_m\| \leq CL\|s_n - s_m\|$. It follows that $(t_n)_{n \geq 1}$ is a Cauchy sequence, hence convergent. \square

A Schauder basis $(x_n)_{n \in \mathbb{Z}}$ is called *unconditional* if there exists a constant $M \geq 0$ such that for all finitely non-zero sequences $(c_n)_{n \in \mathbb{Z}}$ and scalar sequences of modulus one $(\epsilon_n)_{n \in \mathbb{Z}}$ we have

$$\left\| \sum_{n \in \mathbb{Z}} \epsilon_n c_n x_n \right\| \leq M \left\| \sum_{n \in \mathbb{Z}} c_n x_n \right\|.$$

A Schauder basis $(x_n)_{n \in \mathbb{Z}}$ is called *conditional* if it is not unconditional.

Proposition 10.2.28. *On a Banach space X with a Schauder basis $(x_n)_{n \in \mathbb{Z}}$ consider the diagonal operator A defined by*

$$A \sum_{n \in \mathbb{Z}} c_n x_n = \sum_{n \in \mathbb{Z}} 2^n c_n x_n, \\ D(A) = \left\{ \sum_{n \in \mathbb{Z}} c_n x_n \in X : \sum_{n \in \mathbb{Z}} 2^n c_n x_n \text{ converges in } X \right\}.$$

Then:

- (1) A is sectorial with $\omega(A) = 0$, and A is densely defined, injective, and has dense range.
- (2) A has a bounded H^∞ -calculus if and only if $(x_n)_{n \in \mathbb{Z}}$ is unconditional.

As a consequence of (1) and Theorem G.5.2, $-A$ generates an analytic C_0 -semigroup which is uniformly bounded and strongly continuous on Σ_ω for every $\omega \in (0, \frac{1}{2}\pi)$. This can also be shown directly by a variation of the proof below.

Proof. In order to show that A is sectorial with $\omega(A) = 0$, let $\omega \in (0, \frac{1}{2}\pi)$. We will frequently use the following estimate (see Lemma 10.2.4):

$$|1 + z| \geq (|z| \vee 1) \sin(\omega), \quad t > 0, \quad z \in \Sigma_{\pi-\omega}. \tag{10.19}$$

Let $z \in \Sigma_{\pi-\omega}$. Then with $\lambda_n(z) = (z + 2^n)^{-1}$, $n \in \mathbb{Z}$, we have

$$\phi_n(z) := |z| |\lambda_n(z)| = \frac{2^{-n} |z|}{|2^{-n} z + 1|} \leq 1 + \frac{1}{|2^{-n} z + 1|} \leq \frac{2}{\sin(\omega)},$$

where we used (10.19) in the last step. Similarly, let

$$\psi(z) := |z| \sum_{n \in \mathbb{Z}} |\lambda_{n+1}(z) - \lambda_n(z)| = \sum_{n \in \mathbb{Z}} \frac{|z|2^{-(n+1)}}{|2^{-(n+1)}z + 1||2^{-n}z + 1|}.$$

Let $m \in \mathbb{Z}$ be the unique integer such that $2^m < |z| \leq 2^{m+1}$. For $n \leq m - 1$, by (10.19) we can estimate

$$\frac{|z|2^{-(n+1)}}{|2^{-(n+1)}z + 1||2^{-n}z + 1|} \leq \frac{2}{\sin(\omega)} \frac{1}{|2^{-n}z + 1|} \leq \frac{2}{\sin^2(\omega)} 2^{-m+n}.$$

For $n \geq m$ we have

$$\frac{|z|2^{-(n+1)}}{|2^{-(n+1)}z + 1||2^{-n}z + 1|} \leq \frac{2^{m-n-1}}{\sin^2(\omega)}.$$

Therefore,

$$\psi(z) \leq \frac{2}{\sin^2(\omega)} \sum_{n \leq m-1} 2^{-m+n} + \frac{1}{\sin^2(\omega)} \sum_{n \geq m} 2^{m-n-1} = \frac{3}{\sin^2(\omega)}.$$

By Lemma 10.2.27, the mapping $R(z)(\sum_{n \in \mathbb{Z}} \alpha_n x_n) := \sum_{n \in \mathbb{Z}} \lambda_n(z) \alpha_n x_n$ is bounded on X and

$$|z| \|R(z)\| \leq 2C(\phi(z) + \psi(z)) \leq \frac{4C}{\sin(\omega)} + \frac{6C}{\sin^2(\omega)}.$$

It follows that $z \in \varrho(-A)$ and $R(z, -A) = R(z)$. This shows that $\Sigma_{\pi-\omega} \subseteq \varrho(A)$, so $\mathbb{C}\overline{\Sigma_\omega} \subseteq \varrho(A)$, and the above bound shows that A is sectorial of angle $\omega(A) \leq \omega$. Injectivity of A is clear from the fact that $(x_n)_{n \in \mathbb{Z}}$ is a Schauder basis. Since $x_n \in \mathbf{D}(A) \cap \mathbf{R}(A)$, the density assertions follow as well.

Next we prove that the boundedness of the H^∞ -calculus of A is equivalent to the unconditionality of the basis $(x_n)_{n \in \mathbb{Z}}$. Suppose first that $(x_n)_{n \in \mathbb{Z}}$ is unconditional, say with unconditionality constant M . Then A admits a bounded H^∞ -calculus of zero angle, given by

$$f(A)x_n = \frac{1}{2\pi i} \int_{\partial \Sigma_\nu} \frac{f(z)}{z - 2^n} x_n \, dz = f(2^n)x_n,$$

for all $f \in H^1(\Sigma_\sigma) \cap H^\infty(\Sigma_\sigma)$ and $0 < \nu < \sigma < \pi$. Clearly, the unconditionality implies $\|f(A)\| \leq M \|f\|_\infty$.

Conversely, suppose that the operator A has a bounded $H^\infty(\Sigma_\omega)$ -calculus for some $\omega \in (0, \pi)$. Let $\omega < \nu < \sigma < \pi$. Letting $\zeta(z) = z(1+z)^{-2}$ we have $\zeta(A)x_n = \zeta(2^n)x_n$. It follows that for $f \in H^\infty(\Sigma_\sigma)$, $f\zeta \in H^1(\Sigma_\sigma)$ and hence

$$f(A)x_n = \frac{1}{\zeta(2^n)} (f\zeta)(A)x_n$$

$$\begin{aligned} &= \frac{1}{2\pi i \zeta(2^n)} \int_{\partial \Sigma_\nu} f(z) \zeta(z) R(z, A) x_n \, dz \\ &= \frac{1}{2\pi i \zeta(2^n)} \int_{\partial \Sigma_\nu} \frac{f(z) \zeta(z)}{z - 2^n} x_n \, dz = f(2^n) x_n. \end{aligned}$$

By a classical interpolation theorem of complex analysis (see Proposition H.2.7), there exists a constant C_σ such that for any bounded sequence $(\alpha_n)_{n \in \mathbb{Z}}$ contained in Σ_σ there exists a function $f \in H^\infty(\Sigma_\sigma)$ of norm $\|f\|_\infty \leq C_\sigma$ such that $f(2^n) = \alpha_n$ for all $n \in \mathbb{Z}$. Then, for any finitely non-zero sequence $(c_n)_{n \in \mathbb{Z}}$,

$$\left\| \sum_{n \in \mathbb{Z}} \alpha_n c_n x_n \right\| = \left\| \sum_{n \in \mathbb{Z}} f(2^n) c_n x_n \right\| = \left\| f(A) \sum_{n \in \mathbb{Z}} c_n x_n \right\| \leq \|f(A)\| \left\| \sum_{n \in \mathbb{Z}} c_n x_n \right\|,$$

where we applied the identity $f(A)x_n = f(2^n)x_n$. Since $\|f(A)\| \leq C_\sigma M_{\omega, A}^\infty$, this proves that $(x_n)_{n \in \mathbb{Z}}$ is unconditional, with unconditionality constant at most $C_\sigma M_{\omega, A}^\infty$. \square

We leave it to the reader to check that Proposition 10.2.28 remains true if the index set I is replaced by either $\mathbb{Z}_{>0}$ or $\mathbb{Z}_{<0}$. The resulting diagonal operators A then have some additional structure: in the case of $I = \mathbb{Z}_{>0}$, A is invertible, and in the case $I = \mathbb{Z}_{<0}$, A is a bounded operator by Lemma 10.2.27. An immediate consequence is the following result.

Corollary 10.2.29. *If X has a conditional Schauder basis $(x_n)_{n \geq 1}$, then the following hold:*

- (1) *there exists an invertible sectorial operator A with $\omega(A) = 0$ such that A does not have a bounded H^∞ -calculus.*
- (2) *there exists a bounded sectorial operator A with $\omega(A) = 0$ such that A does not have a bounded H^∞ -calculus.*

It can be shown that every Banach space with a Schauder basis has a conditional Schauder basis (see the Notes), but it would take us too far afield to prove this result. Instead we choose to present some more concrete examples below and refer the reader to the Notes for a further discussion.

Example 10.2.30. The standard trigonometric system $(e_n)_{n \in \mathbb{Z}}$, $e_n(x) = e^{2\pi i n x}$, is a Schauder basis in $L^p(\mathbb{T})$ for $1 < p < \infty$ by Proposition 5.2.7. Consider the diagonal operator

$$A\phi := \sum_{n \in \mathbb{Z}} 2^n \widehat{\phi}(n) e_n, \quad \phi \in L^p(\mathbb{T}),$$

with its natural domain consisting of all $\phi \in L^p(\mathbb{T})$ for which this series converges in $L^p(\mathbb{T})$. By Proposition 10.2.28, A is sectorial of angle 0. By Proposition 10.2.28, A has a bounded H^∞ -calculus if and only if $(e_n)_{n \in \mathbb{Z}}$ is an unconditional basis, and in Example 4.1.12 it was shown that this is the case if and only if $p = 2$.

In order to give an example of a sectorial operator on a Hilbert space without a bounded H^∞ -calculus we will use a variation of Example 10.2.30 on weighted spaces. The only fact which will be needed is that the periodic Hilbert transform \tilde{H} introduced in Chapter 5,

$$\tilde{H}\left(\sum_{k \in \mathbb{Z}} a_k e_k\right) := -i \sum_{k \in \mathbb{Z}} \operatorname{sgn}(k) a_k e_k$$

is bounded on the weighted space $L^2(\mathbb{T}, w)$ with $w(x) = |x|^\alpha$ and $\alpha \in (-1, 1)$. In order to be self-contained we include a proof, which actually extends without additional difficulty to $p \in (1, \infty)$ and the UMD-valued setting.

Proposition 10.2.31. *Let X be a UMD Banach space and let $p \in (1, \infty)$. Let $\alpha \in (-1, p - 1)$ and set $w(x) = |x|^\alpha$. Then the Hilbert transform H and the periodic Hilbert transform \tilde{H} are bounded on $L^p(\mathbb{R}, w; X)$ and $L^p(\mathbb{T}, w; X)$, respectively.*

Proof. By density it suffices to prove that there exists a constant $C \geq 0$ such that $\|Hf\|_{L^p(\mathbb{R}, w; X)} \leq C\|f\|_{L^p(\mathbb{R}, w; X)}$ for all $f \in C_c(\mathbb{R} \setminus \{0\}; X)$. We start from the identity

$$Hf = w^{-1/p} H(w^{1/p} f) + Tf,$$

where

$$Tf(x) = \frac{1}{\pi} w(x)^{-1/p} \int_{\mathbb{R}} \frac{w(x)^{1/p} - w(y)^{1/p}}{x - y} f(y) dy.$$

Note that the right-hand side is well defined as a Bochner integral in X . The boundedness of the Hilbert transform in $L^p(\mathbb{R}; X)$, which was established in Theorem 5.1.13, gives

$$\|w^{-1/p} H(w^{1/p} f)\|_{L^p(\mathbb{R}, w; X)} = \|H(w^{1/p} f)\|_p \leq \|H\| \|w^{1/p} f\|_p = \|H\| \|f\|_{w,p}.$$

Accordingly it suffices to prove that $\|Tf\|_{L^p(\mathbb{R}, w; X)} \leq C\|f\|_{L^p(\mathbb{R}, w; X)}$. By the identity

$$|x|^{1/p} w(x)^{1/p} |Tf(x)| = \frac{1}{\pi} \int_{\mathbb{R}} k(x/y) |y|^{1/p} w(y)^{1/p} f(y) \frac{dy}{|y|},$$

where $k(y) = |y|^{1/p} \left| \frac{|y|^{\alpha/p - 1}}{y - 1} \right|$, the latter integral can be viewed as a convolution on the multiplicative group $(\mathbb{R} \setminus \{0\}, \cdot)$ with Haar measure $\frac{dy}{|y|}$. Using the assumption $\alpha \in (-1, p - 1)$ with $p \in (1, \infty)$, it is easy to check that $k \in L^1(\mathbb{R} \setminus \{0\}, \frac{dy}{|y|})$. Therefore, by Young's inequality,

$$\begin{aligned} \|Tf\|_{L^p(\mathbb{R}, w; X)} &= \left\| \left| \cdot \right|^{1/p} w^{1/p} Tf \right\|_{L^p(\mathbb{R} \setminus \{0\}, \frac{dy}{|y|})} \\ &\leq \|k\|_{L^1(\mathbb{R} \setminus \{0\}, \frac{dy}{|y|})} \left\| \left| \cdot \right|^{1/p} w^{1/p} f \right\|_{L^p(\mathbb{R} \setminus \{0\}, \frac{dy}{|y|})} \end{aligned}$$

$$= \|k\|_{L^1(\mathbb{R}\setminus\{0\}, \frac{dy}{|y|})} \|f\|_{L^p(\mathbb{R}, w; X)}.$$

This gives the desired estimate, with $C = \|k\|_{L^1(\mathbb{R}\setminus\{0\}, \frac{dy}{|y|})}$.

The boundedness of \tilde{H} follows from the boundedness of H by repeating the transference argument of Proposition 5.2.5, replacing dx by $w(x) dx$ at the appropriate places. \square

Example 10.2.32. Let again $\alpha \in (-1, p - 1)$ with $p \in (1, \infty)$ and $w(x) = |x|^\alpha$. Using Proposition 10.2.31, the proof of Proposition 5.2.7 extends to the weighted setting and we find that the trigonometric system $(e_n)_{n \in \mathbb{Z}}$ is a Schauder basis in $L^p(\mathbb{T}, w)$.

For $f \in L^p(\mathbb{T}, w)$ let

$$A\phi := \sum_{n \in \mathbb{Z}} 2^n \widehat{\phi}(n) e_n$$

with its natural domain. By Proposition 10.2.28, A is sectorial of angle 0. We will show that A has a bounded H^∞ -calculus if and only if $p = 2$ and $\alpha = 0$.

It suffices to prove the ‘only if’ part. Let us assume that A has a bounded $H^\infty(\Sigma_\sigma)$ -calculus for some $\sigma \in (0, \pi)$. As in Example 10.2.30, an application of Proposition 10.2.28 gives the necessity of the condition $p = 2$. To show that $\alpha = 0$ we note that the operators A^{is} , $s \in \mathbb{R}$, are bounded on $L^p(\mathbb{T}, w)$ by the boundedness of the $H^\infty(\Sigma_\sigma)$ -calculus on this space (note that $z \mapsto z^{is} = \exp(is(\log|z| + i \arg(z)))$ belongs to $H^\infty(\Sigma_{\pi-\delta})$ for every $\delta \in (0, \pi)$). The following argument shows that the boundedness of operators A^{is} for some $s \notin \frac{1}{\log(2)}\mathbb{N}$ forces $\alpha = 0$.

As in the proof of Proposition 10.2.28, the H^∞ -calculus of A is given by $f(A)e_n = f(2^n)e_n$ for $f \in H^\infty(\Sigma_\sigma)$. In particular, taking $f(z) = z^{is}$, we find that $A^{is}e_n = e^{2\pi i \log(2)sn} e_n = T(s \log(2))e_n$, where $T(s)$ denotes right-translation over s . Thus we find that $T(s)$ is a bounded operator on $L^p(\mathbb{T}, w)$. But it is easy to check that this is only true for $\alpha = 0$.

Later we will see that this example admits a different interpretation: it provides an operator A on $L^p(\mathbb{T}, w)$ which has bounded imaginary powers for all $p \in (1, \infty)$ but has a bounded H^∞ -calculus only for $p = 2$.

10.3 R -boundedness of the H^∞ -calculus

This section is devoted to a study of the R -boundedness of various classes of operators of the form $f(A)$, where A is a sectorial operator, possibly with a bounded H^∞ -calculus. We remind the reader of the fact that throughout this chapter we work over the complex scalar field. ‘ R -boundedness’ therefore refers to random sums with complex Rademacher variables. At the expense of an additional numerical constant the corresponding results for real Rademacher sums hold as well and follow by estimating random sums involving real Rademachers in terms of the corresponding sums involving complex

Rademachers by means of Proposition 6.1.19. Most proofs, however, also work for real Rademachers, and in those cases no additional constant is obtained. We let the interested reader check the particular instances at hand.

10.3.a R -sectoriality

As a first step in our programme it is of interest to study the R -boundedness of the operators $zR(z, A)$ as they appear in the Dunford calculus by writing

$$f(A) = \frac{1}{2\pi i} \int_{\partial\Sigma} f(z)[zR(z, A)] \frac{dz}{z}.$$

This leads to the notion of R -sectoriality:

Definition 10.3.1 (R -sectorial operators). *A sectorial operator A is called R -sectorial if for some $\omega(A) < \sigma < \pi$ the family*

$$\mathcal{T}_{\sigma,A} := \{zR(z, A) : z \in \mathbb{C}\overline{\Sigma_\sigma}\}$$

is R -bounded.

The *angle of R -sectoriality* is the number

$$\omega_R(A) := \inf \{ \sigma \in (\omega(A), \pi) : \mathcal{T}_{\sigma,A} \text{ is } R\text{-bounded} \}.$$

For $\omega_R(A) < \sigma < \pi$, the R -bound of $\mathcal{T}_{\sigma,A}$ will be denoted by $M_{\sigma,A}^R$.

The class of γ -sectorial operators is defined similarly, replacing R -boundedness by γ -boundedness. The associated angle and bounds are denoted by $\omega_\gamma(A)$ and $M_{\sigma,A}^\gamma$. By Theorem 8.1.3, R -boundedness implies γ -boundedness, and thus every R -sectorial operator is γ -sectorial, and when X has finite co-type these notions are equivalent.

The Dunford calculus of an R -sectorial operator is R -bounded:

Proposition 10.3.2 (R -boundedness of the Dunford calculus). *Let A be an R -sectorial operator on X and let $\omega_R(A) < \sigma < \pi$. Then the set*

$$\{f(A) : f \in H^1(\Sigma_\sigma), \|f\|_{H^1(\Sigma_\sigma)} \leq 1\}$$

is R -bounded, with R -bound at most $\frac{1}{\pi}M_{\sigma,A}^R$.

Proof. Fixing an arbitrary $\omega_R(A) < \nu < \sigma$, we have

$$f(A) = \frac{1}{2\pi i} \int_{\partial\Sigma_\nu} f(z)[zR(z, A)] \frac{dz}{z}.$$

Since A is R -sectorial, $\{zR(z, A) : z \in \partial\Sigma_\nu \setminus \{0\}\}$ is R -bounded with constant $M_{\nu,A}^R$. Hence, by Theorem 8.5.2, the set in the statement of the proposition is R -bounded, with R -bound at most $\frac{1}{\pi}M_{\nu,A}^R$. Since this is true for all $\omega_R(A) < \nu < \pi$, by Proposition 8.1.22 we may pass to the limit $\nu \uparrow \sigma$ to obtain the desired bound $\frac{1}{\pi}M_{\sigma,A}^R$. \square

From Theorem G.5.2 we know that if A is densely defined and sectorial of angle $\omega(A) < \frac{1}{2}\pi$, then $-A$ generates a bounded analytic C_0 -semigroup $(S(\zeta))_{\zeta \in \Sigma_\eta}$ for every $\eta \in (0, \frac{1}{2}\pi - \omega(A))$, given by an inverse Laplace transform representation. By the same proof as in Proposition 10.3.2, this representation implies that if A is R -sectorial and $\omega(A) < \frac{1}{2}\pi$, then $(S(\zeta))_{\zeta \in \Sigma_\eta}$ is R -bounded for every $\eta \in (0, \frac{1}{2}\pi - \omega_R(A))$. In fact more is true:

Proposition 10.3.3. *Let A be a densely defined sectorial operator of angle $< \frac{1}{2}\pi$ on a Banach space X and let $(S(t))_{t \geq 0}$ be the bounded analytic C_0 -semigroup generated by $-A$ (see Theorem G.5.2). The following assertions are equivalent:*

- (1) A is R -sectorial with $\omega_R(A) < \frac{1}{2}\pi$;
- (2) $\{tR(it, A) : t \in \mathbb{R} \setminus \{0\}\}$ is R -bounded;
- (3) $\{S(z) : z \in \Sigma_\omega\}$ is R -bounded for some $\omega \in (0, \frac{1}{2}\pi)$;
- (4) $\{S(t) : t \geq 0\}$ and $\{tAS(t) : t \geq 0\}$ are R -bounded.

In this situation we have $\sup\{\omega \in (0, \frac{1}{2}\pi) : (3) \text{ holds}\} = \frac{1}{2}\pi - \omega_R(A)$.

From the proof it is easy to extract explicit estimates for the R -bounds of the sets in (3) and (4) analogous to the one of Proposition 10.3.2. Likewise the proof produces explicit estimates for the abscissa $\omega_R(A)$ and the constants $M_{\sigma, A}^R$ in terms of the R -bounds in (3) and (4).

Proof. (1) \Leftrightarrow (2): Repeating the proof of Proposition 10.1.6, the condition in (2) is seen to be equivalent to the R -boundedness of $\lambda R(\lambda, A)$ on two rotated sectors $\pm i\Sigma_\omega$ for some $0 < \omega < \frac{1}{2}\pi$. By Proposition 8.5.8 the latter implies the R -boundedness of $\lambda R(\lambda, A)$ in the remaining part of the left half-plane.

(1) \Rightarrow (4): The R -boundedness of the set $\{S(t) : t > 0\}$ is an immediate consequence of Propositions 10.2.7; and 10.3.2; alternatively one can use the inverse Laplace representation formula for $S(t)$ and proceed as in the proof of Proposition 10.3.2. Note that both arguments also establish the implication (1) \Rightarrow (3). The R -boundedness of the set $\{tAS(t) : t > 0\}$ follows from Proposition 10.3.2 in combination with Lemma 10.2.8.

(4) \Rightarrow (3): The proof is similar to the proof of (2) \Rightarrow (1) in Theorem G.5.3. For the reader's convenience we indicate the main steps.

Let

$$0 < \delta < \left\{ \sin(\omega), \frac{1}{eM} \right\},$$

where M is the R -bound of $\{tAS(t) : t \geq 0\}$. Then $\bigcup_{t>0} B(t, \delta t) = \Sigma_\eta$ with $\delta = \sin(\eta)$; note that $0 < \eta < \omega$. For any $z \in \Sigma_\eta$, choose $t = t(z) > 0$ such that $z \in B(t, \delta t)$. Then we can express $S(z)$ in terms of the Taylor expansion of $z \mapsto S(z)$ in a point $t > 0$:

$$S(z) = S(t) + \sum_{n \geq 1} \frac{1}{n!} (-A)^n S(t) (z - t)^n$$

$$= S(t) + \sum_{n \geq 1} \frac{n^n}{n!} \left(-(t/n)AS(t/n) \left(\frac{z}{t} - 1 \right) \right)^n.$$

Using Proposition 8.1.24 (with $I = \Sigma_\eta$) together with the inequality $n^n \leq n!e^n$, and noting that $|z - t| < \delta t$, we obtain

$$\mathcal{R}(\{S(z) : |\arg(z)| \leq \delta\}) \leq \mathcal{R}(\{S(t) : t \geq 0\}) + \sum_{n \geq 1} e^n M^n \delta^n.$$

The series on the right-hand side is convergent by the choice of δ .

(3) \Rightarrow (1): Let $0 < \delta' < \delta$. The R -boundedness of the operators $\lambda R(\lambda, A)$ on the punctured lines $e^{\pm \frac{1}{2}\pi i \delta'}(\mathbb{R} \setminus \{0\})$ follows from Theorem 8.5.2 and the representation of the resolvent as the Laplace transform of the C_0 -semigroups $(S(e^{\pm i \delta'} t))_{t \geq 0}$. As in the proof of (1) \Rightarrow (4), the R -boundedness in $\mathbb{C}\overline{\Sigma_{\frac{1}{2}\pi - \delta}}$ follows from this by Proposition 8.5.8. \square

10.3.b The main R -boundedness result

The main result of this subsection is formulated under two different geometric assumptions on X in terms of double random sums:

- (a) the *triangular contraction property* with associated constant Δ_X (see Definition 7.5.7);
- (b) the *Pisier contraction property* with associated constants α_X and α_X^\pm (see Definition 7.5.1 and Proposition 7.5.4).

Pisier's contraction property trivially implies the triangular contraction property. Every UMD space has the triangular contraction property (Theorem 7.5.9), and a Banach lattice has Pisier's contraction property if and only if it has finite cotype (Theorem 7.5.20).

Somewhat informally, the main result below states that

- (a) if X has the triangular contraction property and A has a bounded H^∞ -calculus, then A is R -sectorial;
- (b) if X has Pisier's contraction property and A has a bounded H^∞ -calculus, then the full H^∞ -calculus of A is R -bounded.

We recall the notation $M_{\sigma, A}^\infty$ for the boundedness constant of the $H^\infty(\Sigma_\sigma)$ -calculus of A .

Theorem 10.3.4 (R -sectoriality, R -boundedness of the H^∞ -calculus).

Let A be a sectorial operator on a Banach space X and let $\omega(A) < \sigma < \pi$. If A has a bounded $H^\infty(\Sigma_\sigma)$ -calculus, then:

- (1) for all $\sigma < \vartheta < \pi$, $0 < \delta < \vartheta - \sigma$, and $f \in H^1(\Sigma_\vartheta)$, the set

$$\{f(zA) : |\arg(z)| \leq \delta\}$$

is R -bounded, with R -bound at most $C_{\delta, \sigma, \vartheta} M_{\sigma, A}^\infty \|f\|_{H^1(\Sigma_\vartheta)}$;

- (2) if X has the triangular contraction property, and A is densely defined, then A is R -sectorial with $\omega_R(A) \leq \omega_{H^\infty}(A)$, and for all $\omega_{H^\infty}(A) < \sigma < \vartheta < \pi$ the set

$$\{f(A) : f \in H^1(\Sigma_\vartheta), \|f\|_{H^1(\Sigma_\sigma)} \leq 1\}$$

is R -bounded, with R -bound at most $C_{\sigma,\vartheta}(M_{\sigma,A}^\infty)^2 \Delta_X$;

- (3) if X has Pisier's contraction property, and A is densely defined and has a dense range and a bounded $H^\infty(\Sigma_\eta)$ -calculus for some $\omega(A) < \eta < \sigma$, then the set

$$\{f(A) : f \in H^\infty(\Sigma_\sigma), \|f\|_{H^\infty(\Sigma_\sigma)} \leq 1\}$$

is R -bounded, with R -bound at most $C_{\eta,\sigma}(M_{\eta,A}^\infty)^2 \alpha_X^- \alpha_X^+$.

The attentive reader will notice that the assumption that A is densely defined and has dense range in (3) is redundant provided we interpret $f(A)$ as a bounded operator on $\overline{D(A)} \cap R(A)$. In the formulation as stated the operators $f(A)$ are defined on X .

The proof of this theorem requires some preparation. In Section 10.3.c we associate certain unconditional decompositions to the H^∞ -calculus of A . The proof of Theorem 10.3.4 will be given in Section 10.3.d.

Examples of R -bounded sets associated with a sectorial operator A

We continue with several examples of applications of Proposition 10.3.2 and Theorem 10.3.4.

Example 10.3.5. Let A be R -sectorial and let $\omega_R(A) < \sigma < \pi$. By Proposition 10.3.2, for all $\beta > \alpha > 0$ and $0 < \delta < \pi - \sigma$, the set

$$\{(zA)^\alpha (I + zA)^{-\beta} : |\arg(z)| \leq \delta\}$$

is R -bounded. These operators are to be interpreted as $f_{\alpha,\beta}(A)$ with

$$f_{\alpha,\beta}(\lambda) = \frac{\lambda^\alpha}{(1 + \lambda)^\beta}.$$

Similar interpretations apply below. Clearly, for $|\arg(z)| \leq \delta$ the functions $f_{\alpha,\beta}(z \cdot)$ belong to $H^1(\Sigma_\sigma)$ with norms $\|f_{\alpha,\beta}(z \cdot)\|_{H^1(\Sigma_\sigma)} \leq C_{\sigma+\delta}$, and therefore Proposition 10.3.2 gives the required result.

By the same reasoning, if $\omega_R(A) < \sigma < \frac{1}{2}\pi$, then for all $\alpha > 0$ and $0 < \delta < \frac{1}{2}\pi - \sigma$ the set

$$\{(zA)^\alpha e^{-zA} : |\arg(z)| \leq \delta\}$$

is R -bounded.

The above two sets are also R -bounded under the alternative assumption that A is a sectorial operator with a bounded $H^\infty(\Sigma_\sigma)$ -calculus for some $\sigma \in (0, \pi)$; this time the result follows from Theorem 10.3.4(1).

The next example shows that the triangular contraction property cannot be omitted from Theorem 10.3.4(2).

Example 10.3.6. Let X be a Banach space. On the Rademacher space $\varepsilon(X) = \varepsilon^2(X)$ (see Section 6.3) we define the operator A by

$$A((x_n)_{n \geq 1}) := (2^n x_n)_{n \geq 1} \quad (10.20)$$

with its natural maximal domain consisting of those sequences $(x_n)_{n \geq 1} \in \varepsilon(X)$ for which $(2^n x_n)_{n \geq 1}$ belongs to $\varepsilon(X)$ again. By Kahane's contraction principle, A is sectorial of zero angle. Moreover, A has a bounded $H^\infty(\Sigma_\sigma)$ -calculus for any $0 < \sigma < \pi$, given by

$$f((x_n)_{n \geq 1}) := (f(2^n)x_n)_{n \geq 1};$$

this easily follows by verifying the conditions of Theorem 10.2.14. If X has the triangular contraction property, then so does $\varepsilon(X)$, and therefore A is R -sectorial by Theorem 10.3.4(2).

Let now X be an arbitrary Banach space and suppose that the operator A defined by (10.20) is R -sectorial. We will show that X has the triangular contraction property. Let $M \geq 1$ be an arbitrary integer, set $\lambda_j := 2^{M(j+\frac{1}{2})}$ for $j \in \mathbb{Z}$, and let $(x_{n,k})_{k,n=1}^K$ be a sequence in X . Define the elements $x^{(k)} = (x_n^{(k)})_{n \geq 1} \in \varepsilon(X)$ by $x_{2^M n}^{(k)} := x_{n,k}$ for $n \in \{1, \dots, K\}$ and $x_j^{(k)} := 0$ for the remaining coordinates. Then, by the assumed R -sectoriality of A ,

$$\begin{aligned} & \mathbb{E}'\mathbb{E} \left\| \sum_{k=1}^K \sum_{n=1}^K \varepsilon'_k \varepsilon_n \lambda_{n-k} (1 + \lambda_{n-k})^{-1} x_{n,k} \right\|_X^2 \\ &= \mathbb{E}' \left\| \sum_{k=1}^K \varepsilon'_k (1 + \lambda_k^{-1} A)^{-1} x^{(k)} \right\|_{\varepsilon(X)}^2 \\ &\leq (M_{\sigma,A}^R)^2 \mathbb{E}' \left\| \sum_{k=1}^K \varepsilon'_k x^{(k)} \right\|_{\varepsilon(X)}^2 \\ &= (M_{\sigma,A}^R)^2 \mathbb{E}'\mathbb{E} \left\| \sum_{k=1}^K \sum_{n=1}^K \varepsilon'_k \varepsilon_n x_{n,k} \right\|_X^2. \end{aligned}$$

Letting $M \rightarrow \infty$, we obtain

$$\mathbb{E}'\mathbb{E} \left\| \sum_{k=1}^K \sum_{n=1}^k \varepsilon'_k \varepsilon_n x_{n,k} \right\|_X^2 \leq (M_{\sigma,A}^R)^2 \mathbb{E}'\mathbb{E} \left\| \sum_{k=1}^K \sum_{n=1}^K \varepsilon'_k \varepsilon_n x_{n,k} \right\|_X^2.$$

This shows that X has the triangular projection property, with constant $\Delta_X \leq M_{\sigma,A}^R$.

Also Pisier's contraction property cannot be omitted in Theorem 10.3.4(3):

Example 10.3.7. As we have seen in Example 10.2.26, $A = -\Delta$ is sectorial and has a bounded H^∞ -calculus of zero angle on $L^p(\mathbb{R}^d; X)$ whenever X is a UMD space and $1 < p < \infty$. Theorem 10.3.4(3) implies that if in addition X has Pisier's contraction property, then for any $0 < \sigma < \pi$ the set

$$\{f(-\Delta) : f \in H^\infty(\Sigma_\sigma), \|f\|_{H^\infty(\Sigma_\sigma)} \leq 1\} \quad (10.21)$$

is R -bounded. (Alternatively, one can derive this from Corollary 8.3.23, where even more general Fourier multiplier operators are considered.)

Let now X be an arbitrary UMD Banach space and let again $1 < p < \infty$. For $s \in \mathbb{R}$ consider the functions $f_s(z) := z^{is}$. These functions are uniformly bounded in $H^\infty(\Sigma_\sigma)$ for each $0 < \sigma < \pi$, and therefore the operators $f_s(-\Delta) =: (-\Delta)^{is}$ are well defined and uniformly bounded on $L^p(\mathbb{R}^d; X)$. Up to a normalising constant, the set

$$\{(-\Delta)^{is} : s \in (0, 1]\} \quad (10.22)$$

is a subset of the set in (10.21). In Section 10.5 we will show that if the set in (10.22) is R -bounded, then X has Pisier's contraction property.

10.3.c Unconditional decompositions associated with A

In the setting of diagonal operators on Schauder bases, Proposition 10.2.28 revealed a clear connection between boundedness of H^∞ -calculi and unconditionality. We will now develop this idea more systematically by showing that the H^∞ -calculus of a general sectorial operator A can be understood in terms of unconditional "decompositions" associated the operator A . To explain this further, suppose that A has a bounded H^∞ -calculus on a Banach space X , let $\omega_{H^\infty}(A) < \sigma < \pi$, and consider a function $f \in H^1(\Sigma_\sigma)$ satisfying

$$\sum_{n \in \mathbb{Z}} f(2^n z) = 1, \quad z \in \Sigma_\sigma. \quad (10.23)$$

Such functions can be constructed by taking any $\psi \in H^1(\Sigma_\sigma)$ satisfying $\int_0^\infty \psi(t) \frac{dt}{t} = 1$, and putting

$$f(z) := \int_1^2 \psi(tz) \frac{dt}{t}. \quad (10.24)$$

Applying the Calderón reproducing formula of Proposition 10.2.15, in combination with the unconditionality result proved in Lemma 10.3.8 below the identity (10.23) will give an unconditionally convergent decomposition

$$x = \sum_{n \in \mathbb{Z}} f(2^n A)x, \quad x \in \overline{D(A) \cap R(A)}.$$

The operators $f(2^n A)$ can thus be viewed as analogues to "coordinate projections", the main difference being that the operators $f(2^k A)$ and $f(2^\ell A)$ are

no longer disjoint projections for $k \neq \ell$, but have some “overlap”. Reasoning along the same lines, for $g(z) := z(1+z)^{-1}$ the operators $g(2^n A) = 2^n A(I + 2^n A)^{-1} = A(2^{-n} + A)^{-1}$ can be viewed as analogues to “partial sum projections” (recall from Proposition 10.1.7 that $A(t+A)^{-1} \rightarrow I$ strongly on $\overline{R(A)}$). It turns out that this can be used to show that the family $\{g(2^n A) : n \in \mathbb{Z}\}$ is R -bounded if X has the triangular contraction property.

It will turn out that such results indeed hold for general operators A with a bounded H^∞ -calculus and will essentially follow from the unconditional convergence of the sums $\sum_{n \in \mathbb{Z}} f(2^n A)x$. The main technical tool for this is the following lemma.

Lemma 10.3.8 (Unconditionality). *Let A be a sectorial operator on a Banach space X with a bounded H^∞ -calculus. Let $\omega_{H^\infty}(A) < \sigma < \vartheta < \pi$. If $f \in H^1(\Sigma_\vartheta)$, then:*

(1) *for all finite subsets $F \subseteq \mathbb{Z}$ and scalars $|\alpha_j| \leq 1$, $j \in F$, we have*

$$\sup_{t>0} \left\| \sum_{j \in F} \alpha_j f(2^j t A) \right\| \leq K_{\vartheta-\sigma} M_{\sigma,A}^\infty \|f\|_{H^1(\Sigma_\vartheta)}, \quad (10.25)$$

where $M_{\sigma,A}^\infty$ is the boundedness constant of the $H^\infty(\Sigma_\sigma)$ -calculus of A ;

(2) *if, in addition, f satisfies*

$$\sum_{n \in \mathbb{Z}} f(2^n z) = 1, \quad z \in \Sigma_\sigma,$$

then

$$x = \sum_{n \in \mathbb{Z}} f(2^n A)x, \quad x \in \overline{D(A) \cap R(A)},$$

with unconditional convergence of the sum.

Proof. (1): Consider the function $g : \Sigma_\sigma \rightarrow \mathbb{C}$,

$$g(z) := \sum_{j \in F} \alpha_j f(2^j tz),$$

with $t > 0$, $F \subseteq \mathbb{Z}$ finite, and $|\alpha_j| \leq 1$ for $j \in F$. By Proposition H.2.3 (applied to the functions $t \mapsto f(tz)$), g belongs to $H^1(\Sigma_\sigma) \cap H^\infty(\Sigma_\sigma)$ with

$$\|g\|_{H^\infty(\Sigma_\sigma)} \leq K_{\vartheta-\sigma} \|f\|_{H^1(\Sigma_\vartheta)}. \quad (10.26)$$

From the boundedness of the $H^\infty(\Sigma_\sigma)$ -calculus of A we then obtain

$$\left\| \sum_{j \in F} \alpha_j f(2^j t A) \right\| = \|g(A)\| \leq M_{\sigma,A}^\infty \|g\|_{H^\infty(\Sigma_\sigma)} \leq K_{\vartheta-\sigma} M_{\sigma,A}^\infty \|f\|_{H^1(\Sigma_\vartheta)}.$$

(2): In view of the bound proved in (1) it suffices to consider elements $x \in D(A) \cap R(A)$. Now (10.26) implies

$$\sum_{n=-M}^N |f(2^n z)| \leq K_{\vartheta-\sigma} \|f\|_{H^1(\Sigma_\vartheta)}, \quad z \in \Sigma_\sigma. \quad (10.27)$$

Let us write $x = \zeta(A)y = A(I + A)^{-2}y$. For $\omega_{H^\infty}(A) < \nu < \sigma$, the functions $f(2^n \cdot)\zeta(\cdot)$ belong to $H^1(\Sigma_\nu)$, and by dominated convergence and the properties of the functional calculus we obtain

$$\begin{aligned} \sum_{n=-M}^N f(2^n A)x &= \sum_{n=-M}^N f(2^n A)\zeta(A)y \\ &= \sum_{n=-M}^N \frac{1}{2\pi i} \int_{\partial\Sigma_\nu} f(2^n z)R(z, A)\zeta(z)y \, dz \\ &\xrightarrow{M, N \rightarrow \infty} \frac{1}{2\pi i} \int_{\partial\Sigma_\nu} R(z, A)\zeta(z)y \, dz = \zeta(A)y = x, \end{aligned}$$

with absolute convergence of the sum on the left hand side because of (10.27).

This proves the unconditional (and even absolute) convergence for $x \in \mathbf{D}(A) \cap \mathbf{R}(A)$. To prove the unconditional convergence for $x \in \overline{\mathbf{D}(A) \cap \mathbf{R}(A)}$, let $\varepsilon > 0$ be arbitrary and fixed, and choose $y \in \mathbf{D}(A) \cap \mathbf{R}(A)$ such that $\|x - y\| < \varepsilon$. Since $y = \sum_{n \in \mathbb{Z}} f(2^n A)y$ converges unconditionally we may choose a finite set $F_\varepsilon \subseteq \mathbb{Z}$ such that for every finite set $F \subseteq \mathbb{Z}$ containing F_ε we have $\|y - \sum_{n \in F} f(2^n A)y\| < \varepsilon$. Now let $F \subseteq \mathbb{Z}$ be a finite set containing F_ε . Then from (10.25) we obtain

$$\begin{aligned} \left\| x - \sum_{n \in F} f(2^n A)x \right\| &\leq \|x - y\| + \left\| y - \sum_{n \in F} f(2^n A)y \right\| + \left\| \sum_{n \in F} f(2^n A)(y - x) \right\| \\ &\leq 2\varepsilon + K_{\vartheta-\sigma} M_{\sigma, A}^\infty \|f\|_{H^1(\Sigma_\vartheta)} \varepsilon, \end{aligned}$$

and the unconditional convergence follows. \square

Remark 10.3.9. For functions $f \in H^1(\Sigma_\vartheta)$ of the form (10.24) with $z \mapsto \psi(z) \log(z) \in H^1(\Sigma_\sigma)$ and $\omega(A) < \sigma < \vartheta$, part (2) of the lemma remains true for general sectorial operators A ; in this case, Proposition 10.2.5 and (10.12) give the following version of the bound in (1):

$$\left\| \sum_{k=m}^n f(2^k A)x \right\| \leq C_{\psi, \sigma} \|x\|, \quad x \in \overline{\mathbf{D}(A) \cap \mathbf{R}(A)},$$

uniformly with respect to $m, n \geq 1$, where $C_{\psi, \sigma}$ is the constant in the proof of Proposition 10.2.5.

10.3.d Proof of the main result

Proof of Theorem 10.3.4(1). Fix $f \in H^1(\Sigma_\vartheta)$ and $0 < \delta < \vartheta - \sigma$. We need to prove the following estimate

$$\mathcal{R}(\{f(zA) : |\arg(z)| \leq \delta\}) \leq C_{\delta,\sigma,\vartheta} M_{\sigma,A}^\infty \|f\|_{H^1(\Sigma_\vartheta)}.$$

Let $\delta < \omega < \vartheta - \sigma$ and put $f_{\pm\omega}(z) := f(e^{\pm i\omega} z)$ for $z \in \Sigma_\sigma$. Since $f_{\pm\omega} \in H^1(\Sigma_{\vartheta-\omega})$ of norm $\|f_{\pm\omega}\|_{H^1(\Sigma_{\vartheta-\omega})} \leq \|f\|_{H^1(\Sigma_\vartheta)}$, Lemma 10.3.8 gives

$$\left\| \sum_{n \in F} \epsilon_n f_{\pm\omega}(2^n A) \right\| \leq K_{\vartheta-\sigma} M_{\sigma,A}^\infty \|f\|_{H^1(\Sigma_\vartheta)}$$

for all finite $F \subseteq \mathbb{Z}$ and all finite sequences of modulus one scalars $(\epsilon_n)_{n \in F}$. In particular, the condition of Proposition 8.4.6(1) is satisfied, and therefore for all $t > 0$ we have

$$\mathcal{R}(\{f_{\pm\omega}(2^n tA) : n \in \mathbb{Z}\}) \leq K_{\vartheta-\sigma} M_{\sigma,A}^\infty \|f\|_{H^1(\Sigma_\vartheta)}.$$

Now Proposition 8.5.8 gives

$$\mathcal{R}(\{f(zA) : |\arg(z)| \leq \delta\}) \leq 4K_{\vartheta-\sigma} \left(1 + \frac{1}{\pi} \tan\left(\frac{\delta}{\omega} \frac{1}{2}\pi\right)\right) M_{\sigma,A}^\infty \|f\|_{H^1(\Sigma_\vartheta)}.$$

Letting $\omega \uparrow \vartheta - \sigma$ the desired result is obtained, with constant $C_{\delta,\sigma,\vartheta} = 4K_{\vartheta-\sigma} \left(1 + \frac{1}{\pi} \tan\left(\frac{\delta}{\vartheta-\sigma} \frac{\pi}{2}\right)\right)$. \square

For the proof of Theorem 10.3.4(2) we need some preparation.

Lemma 10.3.10. *The function $f : \mathbb{C} \setminus (-\infty, 0] \rightarrow \mathbb{C}$,*

$$f(z) = \frac{z^{1/2}}{(1+z)^{1/2}(1+2z)^{1/2}},$$

belongs to $H^1(\Sigma_\sigma)$, $0 < \sigma < \pi$, and

$$\|f\|_{H^1(\Sigma_\sigma)} \leq \frac{4}{\sin(\sigma \vee \frac{\pi}{2})}.$$

Proof. Let $r > 0$ and $0 < |\nu| \leq \sigma < \pi$ be arbitrary. By Lemma 10.2.4 we have $|1 + re^{i\nu}| \geq (r \vee 1) \sin(\sigma \vee \frac{1}{2}\pi)$ and therefore

$$|f(re^{i\nu})| \leq \frac{r^{1/2}}{(r \vee 1)^{1/2}((2r) \vee 1)^{1/2} \sin(\sigma \vee \frac{1}{2}\pi)} \leq \frac{r^{1/2}}{(r \vee 1) \sin(\sigma \vee \frac{1}{2}\pi)}.$$

This estimate easily implies

$$\int_0^\infty |f(te^{i\nu})| \frac{dt}{t} \leq \frac{4}{\sin(\sigma \vee \frac{1}{2}\pi)},$$

which is the required bound on the H^1 -norm of f . \square

Proof of Theorem 10.3.4(2). We begin by proving the R -boundedness of the set $\{(I + zA)^{-1} : |\arg(z)| \leq \delta\}$ for any fixed $0 < \delta < \pi - \sigma$. Choose ω and ϑ such that

$$\delta < \omega < \pi - \vartheta < \pi - \sigma.$$

The idea of the proof is to deduce this from Proposition 8.4.6(2) for a suitable family $(U_j)_{j \in \mathbb{Z}}$, using Proposition 8.5.8 to discretise the problem.

Fix $t > 0$ and $m, n \in \mathbb{Z}$ with $m < n$. Using the resolvent identity

$$(I + \lambda A)^{-1} - (I + \mu A)^{-1} = A(\mu - \lambda)(I + \lambda A)^{-1}(I + \mu A)^{-1}$$

and a telescoping argument, we obtain

$$\begin{aligned} & (I + 2^m t e^{\pm i\omega} A)^{-1} - (I + 2^n t e^{\pm i\omega} A)^{-1} \\ &= \sum_{j=m}^{n-1} (I + 2^j t e^{\pm i\omega} A)^{-1} - (I + 2^{j+1} t e^{\pm i\omega} A)^{-1} \\ &= \sum_{j=m}^{n-1} 2^j t e^{\pm i\omega} A (I + 2^j t e^{\pm i\omega} A)^{-1} (I + 2^{j+1} t e^{\pm i\omega} A)^{-1} \\ &= \sum_{j=m}^{n-1} f^2(2^j t e^{\pm i\omega} A) = \sum_{j=m}^{n-1} U_j^2, \end{aligned}$$

where f is as in Lemma 10.3.10 and $U_j := f(2^j t e^{\pm i\omega} A)$. Since for the function $f_{\pm\omega} = f(e^{\pm i\omega} \cdot)$, we have

$$\|f_{\pm\omega}\|_{H^1(\Sigma_\vartheta)} \leq \|f\|_{H^1(\Sigma_{\vartheta+\omega})} \leq C_{\vartheta+\omega},$$

where $C_{\vartheta+\omega} := 4/\sin((\vartheta + \omega) \vee \frac{\pi}{2})$, by Lemma 10.3.10. Therefore, by Lemma 10.3.8 (applied the rotated function $z \mapsto f(e^{\pm i\omega} z)$) and give

$$\sup_{t>0} \sup_{m<n} \sup_{|\epsilon_m|, \dots, |\epsilon_{n-1}|=1} \left\| \sum_{j=m}^{n-1} \epsilon_j U_j \right\| \leq C_{\vartheta+\omega} K_{\vartheta-\sigma} M_{\sigma,A}^\infty.$$

Hence by Proposition 8.4.6(2) with $U_n = V_n$ and $T_n = I$,

$$\mathcal{R} \left\{ \sum_{j=m}^{n-1} U_j^2 : m, n \in \mathbb{Z} \right\} \leq C_{\vartheta+\omega}^2 K_{\vartheta-\sigma}^2 (M_{\sigma,A}^\infty)^2 \Delta_X.$$

By the above identities, this gives the R -boundedness of the set

$$\mathcal{S}(t) := \left\{ (I + 2^m t e^{\pm i\omega} A)^{-1} - (I + 2^n t e^{\pm i\omega} A)^{-1} : m, n \in \mathbb{Z}, m < n \right\},$$

with the same R -bound. Next, since A is densely defined, $\lim_{m \rightarrow -\infty} (I + 2^m t e^{\pm i\omega} A)^{-1} x = x$ for all $x \in \overline{D(A)} = X$ by Proposition 10.1.7(1). Therefore the family

$$\{(I + 2^n t e^{\pm i\omega} A)^{-1} - I : n \in \mathbb{Z}\}$$

belongs to the strong operator closure of $\mathcal{S}(t)$ and is therefore R -bounded by Proposition 8.1.22, with the same R -bound. It follows that

$$\mathcal{R}(\{(I + 2^n t e^{\pm i\omega} A)^{-1} : n \in \mathbb{Z}\}) \leq 1 + K_{\vartheta-\sigma}^2 (M_{\sigma,A}^\infty)^2 \Delta_X.$$

So far, $t > 0$ was arbitrary and fixed. Now by Proposition 8.5.8,

$$M_{\pi-\delta,A}^R = \mathcal{R}(\{(I + zA)^{-1} : |\arg(z)| \leq \delta\}) \leq C_{\delta,\sigma} (M_{\sigma,A}^\infty)^2 \Delta_X,$$

where $C_{\delta,\sigma} = 4(1 + \frac{1}{\pi} \tan(\frac{\delta}{\omega} \frac{1}{2}\pi))(1 + K_{\vartheta-\sigma}^2 \Delta_X)$ (we may suppress the dependence on ϑ and ω , since they can be made depend on δ and σ). \square

For the proof of Theorem 10.3.4(3) we also need some preparation.

Lemma 10.3.11. *Let A be a sectorial operator on a Banach space X . Let $\omega(A) < \sigma < \pi$ and let $f \in H^1(\Sigma_\sigma)$ be given. For $\mu \in \mathbb{C}_{\Sigma_\sigma}$ consider $r_\mu(z) := (\mu - z)^{-1}$. Then $r_\mu f \in H^1(\Sigma_\sigma)$ and*

$$(r_\mu f)(A) = R(\mu, A)f(A).$$

Proof. As in Proposition 10.2.6 let

$$\zeta_n(z) = \frac{n}{n+z} - \frac{1}{1+nz} = \frac{(n^2-1)z}{(n+z)(1+nz)}. \tag{10.28}$$

By the multiplicativity of the Dunford calculus (see Theorem 10.2.2)

$$\begin{aligned} (r_\mu f)(A)\zeta_n(A) &= (r_\mu f \zeta_n)(A) = (\zeta_n r_\mu)(A)f(A) \\ &= \zeta_n(A)R(\mu, A)f(A) = R(\mu, A)f(A)\zeta_n(A), \end{aligned}$$

where in the penultimate step we used Proposition 10.2.3 and in the last step the commutativity of the Dunford calculus. Now the required identity follows from the convergence property of the Dunford calculus. \square

Lemma 10.3.12. *Let $0 < \mu < \nu < \pi$. For all $0 < \alpha < 1$ and non-zero $z \in \partial\Sigma_\nu$ the function $\psi_{z,\alpha}(\lambda) := \lambda^\alpha / (z - \lambda)^{2\alpha}$ belongs to $H^1(\Sigma_\mu)$ and*

$$\|\psi_{z,\alpha}\|_{H^1(\Sigma_{\nu-\mu})} \leq C_{\nu-\mu,\alpha} |z|^{-\alpha}$$

with $C_{\nu-\mu,\alpha} = \frac{2}{\alpha} (\sin(\frac{1}{2}\pi \vee (\pi - \theta)))^{2\alpha}$.

Proof. For all $|\theta| < \mu$ we have

$$\begin{aligned} \int_0^\infty |\psi_{z,\alpha}(r e^{i\theta})| \frac{dr}{r} &= \int_0^\infty \frac{r^\alpha}{|z - r e^{i\theta}|^{2\alpha}} \frac{dr}{r} \\ &\leq |z|^{-\alpha} \int_0^\infty \frac{\rho^\alpha}{|1 - \rho e^{-i(\nu-\mu)}|^{2\alpha}} \frac{d\rho}{\rho} =: c_{\nu-\mu,\alpha} |z|^{-\alpha}, \end{aligned}$$

where, by using Lemma 10.2.4,

$$c_{\theta,\alpha} \leq \frac{1}{(\sin(\frac{1}{2}\pi \vee (\pi - \theta)))^{2\alpha}} \int_0^\infty \frac{\rho^\alpha}{(1 \vee \rho^{2\alpha})} \frac{d\rho}{\rho}$$

and

$$\int_0^\infty \frac{\rho^\alpha}{(1 \vee \rho^{2\alpha})} \frac{d\rho}{\rho} = \int_0^1 \rho^\alpha \frac{d\rho}{\rho} + \int_1^\infty \rho^{-\alpha} \frac{d\rho}{\rho} = \frac{2}{\alpha}.$$

□

Lemma 10.3.13. *Let A be a sectorial operator on a Banach space X . Let $\omega(A) < \sigma < \pi$ and let $f \in H^1(\Sigma_\sigma)$ be given. Let $\phi_z(\lambda) := \lambda^{1/2}/(z - \lambda)$. Then for all $\omega(A) < \nu < \sigma$ we have*

$$f(A) = \frac{1}{2\pi i} \int_{\partial\Sigma_\nu} z^{1/2} f(z) \phi_z(A) \frac{dz}{z}. \tag{10.29}$$

Before turning to the proof we must justify the well-definedness of the operators $\phi_z(A)$ and the convergence of integral on the right-hand side. By Lemma 10.3.12, the operators $\phi_z(A)$ are well defined through the Dunford calculus and the family $\{z^{1/2}\phi_z(A) : z \in \partial\Sigma_\nu\}$ is uniformly bounded. This, in turn, combined with the fact that $f \in H^1(\Sigma_\sigma)$, shows that the integral in the statement of the lemma is absolutely convergent.

Comparing (10.29) with the Dunford integral

$$f(A) = \frac{1}{2\pi i} \int_{\partial\Sigma_\nu} f(z) [zR(z, A)] \frac{dz}{z}$$

we see what the lemma achieves: it allows us to replace the bounded function $z \mapsto zR(z, A)$ in the Dunford integral by another function, namely the function $z \mapsto z^{1/2}\phi_z(A)$. The improvement consists of the fact that the operators $z^{1/2}\phi_z(A)$ are obtained through the Dunford calculus of A , whereas the operators $zR(z, A)$ are not (as $\lambda \mapsto z/(\lambda - z)$ does not belong to $H^1(\Sigma_\omega)$ for any $0 < \omega < \pi$).

Proof of Lemma 10.3.13. Let $\omega(A) < \nu < \sigma < \pi$ be as in the statement of the lemma and fix $\omega(A) < \mu < \nu$. Let $\zeta_n, n \geq 1$, be the functions in (10.28) and put

$$\eta_n^\pm(\lambda) := \lambda^{\pm 1/2} \zeta_n(\lambda), \quad \lambda \in \Sigma_\mu.$$

By the multiplicativity of the Dunford calculus,

$$f(A)\zeta_n(A)^2 = (f\zeta_n^2)(A)(\eta^+ \cdot (\eta^- f))(A) = \eta_n^+(A)(\eta_n^- f)(A).$$

For $z \in \partial\Sigma_\nu$ we may apply Lemma 10.3.11 to see that

$$\eta_n^+(A)R(z, A) = (\eta_n^+ r_z)(A).$$

Furthermore, it follows from the identity

$$\eta_n^+(\lambda)r_z(\lambda) = \lambda^{1/2}\zeta_n(\lambda)(z - \lambda)^{-1} = \phi_z(\lambda)\zeta_n(\lambda)$$

and the multiplicativity of the Dunford calculus that

$$(\eta_n^+ r_z)(A) = \phi_z(A)\zeta_n(A), \quad z \in \partial\Sigma_\nu.$$

It follows that

$$\begin{aligned} f(A)\zeta_n(A)^2 &= \frac{1}{2\pi i}\eta_n^+(A) \int_{\partial\Sigma_\nu} \eta_n^-(z)f(z)R(z, A) dz \\ &= \frac{1}{2\pi i}\eta_n^+(A) \int_{\partial\Sigma_\nu} z^{-1/2}\zeta_n(z)f(z)R(z, A) dz \\ &= \frac{1}{2\pi i} \int_{\partial\Sigma_\nu} z^{-1/2}\zeta_n(z)f(z)(\eta_n^+ r_z)(A) dz \\ &= \frac{1}{2\pi i} \int_{\partial\Sigma_\nu} \zeta_n(z)[z^{1/2}f(z)\phi_z(A)]\zeta_n(A) \frac{dz}{z}. \end{aligned}$$

Letting $n \rightarrow \infty$, (10.29) follows from the convergence property of the Dunford calculus and the dominated convergence theorem. \square

Proof of Theorem 10.3.4(3). We must prove the R -boundedness of the set

$$\mathcal{S} := \{f(A) : f \in H^\infty(\Sigma_\sigma), \|f\|_{H^\infty(\Sigma_\sigma)} \leq 1\},$$

along with the stated bound for its R -boundedness constant.

Fix $\omega_{H^\infty}(A) < \eta < \mu < \nu < \sigma$ and first consider a function $f \in H^1(\Sigma_\sigma) \cap H^\infty(\Sigma_\sigma)$. Let $\phi_z(\lambda) = \lambda^{1/2}/(z - \lambda)$ as in Lemma 10.3.13. By that lemma,

$$\begin{aligned} f(A) &= \frac{1}{2\pi i} \int_{\partial\Sigma_\nu} z^{1/2}f(z)\phi_z(A) \frac{dz}{z} \\ &= \sum_{\epsilon=\pm 1} \frac{1}{2\pi i} \epsilon e^{-\epsilon i\nu/2} \int_0^\infty f(e^{-\epsilon i\nu t})\phi_{e^{-\epsilon i\nu}(t^{-1}A)} \frac{dt}{t} \\ &= \sum_{j \in \mathbb{Z}} \sum_{\epsilon=\pm 1} \frac{1}{2\pi i} \epsilon e^{-\epsilon i\nu/2} \int_1^2 f(e^{-\epsilon i\nu 2^j t})\phi_{e^{-\epsilon i\nu}(t^{-1}2^{-j}A)} \frac{dt}{t}. \end{aligned}$$

Fix $f_1, \dots, f_N \in H^1(\Sigma_\sigma) \cap H^\infty(\Sigma_\sigma)$ with $\|f_n\|_\infty \leq 1$ and $x_1, \dots, x_N \in X$. Introducing

$$U_j(t, \epsilon) := \phi_{e^{-\epsilon i\nu}(t^{-1}2^{-j}A)}$$

we can write

$$\sum_{n=1}^N \varepsilon_n f_n(A)x_n = \sum_{j \in \mathbb{Z}} \sum_{\epsilon=\pm 1} \frac{1}{2\pi i} \epsilon e^{-\epsilon i\nu/2} \int_1^2 \sum_{n=1}^N \varepsilon_n f_n(e^{-\epsilon i\nu 2^j t}) U_j^2(t, \epsilon) x_n \frac{dt}{t},$$

where $(\varepsilon_n)_{n \in \mathbb{Z}}$ is a Rademacher sequence. Therefore,

$$\begin{aligned} & \left(\mathbb{E} \left\| \sum_{n=1}^N \varepsilon_n f_n(A) x_n \right\|^2 \right)^{1/2} \\ & \leq \frac{\log(2)}{\pi} \sup_{t>0} \sup_{k \geq 1} \max_{\varepsilon = \pm 1} \left(\mathbb{E} \left\| \sum_{n=1}^N \varepsilon_n \sum_{|j| \leq k} f_n(e^{-\varepsilon i \nu} 2^j t) U_j^2(t, \varepsilon) x_n \right\|^2 \right)^{1/2} \\ & \leq \frac{\log(2)}{\pi} \sup_{t>0} \max_{\varepsilon = \pm 1} \mathcal{R}(\mathcal{S}(t, \varepsilon)) \left(\mathbb{E} \left\| \sum_{n=1}^N \varepsilon_n x_n \right\|^2 \right)^{1/2}, \end{aligned}$$

where for $t > 0$ and $\varepsilon \in \{-1, 1\}$ the operator family $\mathcal{S}(t, \varepsilon)$ is given by

$$\mathcal{S}(t, \varepsilon) := \left\{ \sum_{|j| \leq k} f_n(e^{-\varepsilon i \nu} 2^j t) U_j^2(t, \varepsilon) : n \geq 1, k \geq 1 \right\}.$$

It remains to estimate $\mathcal{R}(\mathcal{S}(t, \varepsilon))$ with a bound that is uniform in $t > 0$ and $\varepsilon \in \{-1, 1\}$. To do so we will apply Proposition 8.4.6(3), for fixed $t > 0$, to the operators $U_n = V_n := U_n(t, \varepsilon)$ and the set

$$\mathcal{T} := \{f_n(z) : z \in \Sigma_\sigma, n \in \mathbb{N}\} \subseteq \{cI : |c| \leq 1\},$$

which is R -bounded with constant 1, by the Kahane contraction principle.

To check the conditions on U_n needed to apply Proposition 8.4.6(3), we apply Lemma 10.3.8, which gives the bound

$$\sup_{t>0} \sup_{m < n} \sup_{|\varepsilon_m|, \dots, |\varepsilon_{n-1}|=1} \left\| \sum_{j=m}^{n-1} \varepsilon_j U_j(t, \varepsilon) \right\| \leq K_{\mu-\eta} M_{\eta,A}^\infty \|\phi_{e^{-\varepsilon i \nu}}^{1/2}\|_{H^1(\Sigma_\mu)},$$

with $\|\phi_{e^{-\varepsilon i \nu}}^{1/2}\|_{H^1(\Sigma_\mu)} \leq C_{\nu-\mu, 1/4}$ by Lemma 10.3.12, with the constant as in the lemma. Thanks to this bound we are in a position to apply Proposition 8.4.6(3) and obtain

$$\mathcal{R}(\mathcal{S}(t, \varepsilon)) \leq K_{\mu-\eta}^2 (M_{\eta,A}^\infty)^2 C_{\nu-\mu, \frac{1}{4}}^2 \alpha_X^- \alpha_X^+.$$

Setting $\mathcal{S}_1 := \{f(A) : f \in H^1(\Sigma_\sigma) \cap H^\infty(\Sigma_\sigma), \|f\|_{H^\infty(\Sigma_\sigma)} \leq 1\}$, this proves that \mathcal{S}_1 is R -bounded and

$$\mathcal{R}(\mathcal{S}_1) \leq \frac{\log(2)}{\pi} \sup_{t>0} \sup_{\varepsilon \in \{-1, 1\}} \mathcal{R}(\mathcal{S}(t, \varepsilon)) \leq K_{\mu-\eta}^2 (M_{\eta,A}^\infty)^2 C_{\nu-\mu, 1/4}^2 \alpha_X^- \alpha_X^+.$$

Finally, since $f(A)\zeta_m(A)x \rightarrow f(A)x$ for all $x \in X = \overline{\mathbf{D}(A) \cap \mathbf{R}(A)}$, by Proposition 8.1.22 \mathcal{S} is contained in the closure of \mathcal{S}_1 in the strong operator topology, and hence \mathcal{S} is R -bounded with the same bound. \square

Remark 10.3.14. If we do not assume that A has dense range and dense domain in Theorem 10.3.4(3), then the above proof still gives the R -boundedness of \mathcal{S}_1 with the bound as stated.

The following simple corollary is of independent interest.

Corollary 10.3.15. *Let A be a sectorial operator on a Banach space X . Consider the function $\phi_z(\lambda) = \lambda^{1/2}/(z - \lambda)$. If, for some $\omega(A) < \nu < \pi$ we have*

$$\int_{\partial\Sigma_\nu} |z^{1/2}\langle\phi_z(A)x, x^*\rangle| \frac{|dz|}{|z|} < \infty$$

for all $x \in X$ and $x^* \in X^*$, then A has a bounded $H^\infty(\Sigma_\sigma)$ -calculus for all $\nu < \sigma < \pi$.

Proof. It has already been observed in Lemma 10.3.13 the operators $\phi_z(A)$ are well defined by the Dunford calculus of A and the operators $z^{1/2}\phi_z(A)$ are uniformly bounded as z ranges over $\partial\Sigma_\nu$.

By a standard closed graph argument there exists a constant $C \geq 0$ such that

$$\int_{\partial\Sigma_\nu} |z^{1/2}\langle\phi_z(A)x, x^*\rangle| \frac{|dz|}{|z|} \leq C\|x\|\|x^*\|$$

for all $x \in X$ and $x^* \in X^*$.

Let $\omega(A) < \nu < \sigma < \pi$, and let $f \in H^1(\Sigma_\sigma) \cap H^\infty(\Sigma_\sigma)$ be given. By Lemma 10.3.13, for $x \in \overline{\mathbf{D}(A)} \cap \mathbf{R}(A)$ we have

$$f(A) = \frac{1}{2\pi i} \int_{\partial\Sigma_\nu} z^{1/2}f(z)\phi_z(A) \frac{dz}{z}.$$

Hence for all $x \in X$ and $x^* \in X^*$,

$$\begin{aligned} |\langle f(A)x, x^*\rangle| &= \frac{1}{2\pi} \|f\|_{H^\infty(\Sigma_\sigma)} \int_{\partial\Sigma_\nu} |z^{1/2}\langle\phi_z(A)x, x^*\rangle| \frac{|dz|}{|z|} \\ &\leq C\|x\|\|x^*\|\|f\|_{H^\infty(\Sigma_\sigma)}. \end{aligned}$$

Hence $\|f(A)x\| \leq \frac{C}{2\pi} \|f\|_{H^\infty(\Sigma_\sigma)} \|x\|$. This shows that condition (2) of Proposition 10.2.11 is satisfied. It follows that A has a bounded $H^\infty(\Sigma_\sigma)$ -calculus with constant $M_{A,\nu}^\infty \leq \frac{C}{2\pi} / \sin(\sigma \vee \frac{1}{2}\pi)$ (recall that this constant has been defined as the best constant in condition (2) of this proposition). \square

10.4 Square functions and H^∞ -calculus

From its early days, the topic of H^∞ -calculus has been intimately connected with square functions. As we will see, the boundedness of suitable square functions associated with a sectorial operator imply that the operator has

a bounded H^∞ -calculus and vice versa. Such results were originally proved for continuous square functions in a Hilbert space setting and subsequently generalised to Banach spaces with finite cotype. A typical example of a square function estimate is the equivalence of norms

$$\left\| \left(\int_0^\infty \left| t^k \frac{d^k}{dt^k} e^{-t\Delta} f \right|^2 \frac{dt}{t} \right)^{1/2} \right\|_{L^p(\mathbb{R}^d)} \approx \|f\|_{L^p(\mathbb{R}^d)}, \quad (10.30)$$

valid for all $f \in L^p(\mathbb{R}^d)$, $1 < p < \infty$ and integers $k \geq 1$. The expression on the left-hand side is the classical Littlewood-Paley g -function norm. As we will see, the equivalence of norms (10.30) will be a simple consequence of the abstract equivalence of norms for continuous square functions associated with the operator $A = -\Delta$.

10.4.a Discrete square functions

We start with a study of discrete square function estimates. Apart from their intrinsic interest they have the additional advantage over their continuous analogues that they can be stated and proved without any geometrical assumptions on the Banach space X . In contrast, the treatment of continuous square functions requires X to have finite cotype in most of the results.

Definition 10.4.1 (Discrete square functions). *Let A be a sectorial operator on a Banach space X , let $\omega(A) < \sigma < \pi$, and consider a function $\phi \in H^1(\Sigma_\sigma)$. Let $(\varepsilon_n)_{n \in \mathbb{Z}}$ be a Rademacher sequence. The discrete square function norm, associated with A and ϕ , of a vector $x \in X$ is defined by*

$$\|x\|_{\phi,A} := \sup_{t>0} \sup_{N \geq 1} \left(\mathbb{E} \left\| \sum_{|n| \leq N} \varepsilon_n \phi(2^n t A) x \right\|^2 \right)^{1/2}$$

whenever this expression is finite.

The supremum over $t > 0$ can be replaced by a supremum by $t \in [1, 2]$, as can be seen by writing $t = s2^n$ with $s \in [1, 2]$ and $n \in \mathbb{Z}$. The parameter t may seem awkward at first sight and can indeed be avoided under suitable assumptions (see Proposition 10.4.8 below).

Remark 10.4.2. In the setting of Definition 10.4.1, for all $x \in D(A) \cap R(A)$ the square function $\|x\|_{\phi,A}$ is finite. To see this, let $\omega(A) < \nu < \sigma$. Writing $x = \zeta(A)y$ with $\zeta(z) = z(1+z)^{-2}$, so $\zeta(A) = A(I+A)^{-2}$ by Proposition 10.2.3, we estimate the Dunford integral:

$$\|\phi(2^n t A)x\| \leq \frac{M_{\nu,A}}{2\pi} \int_{\partial \Sigma_\nu} |\phi(2^n tz)| |\zeta(z)| \|y\| \left| \frac{dz}{z} \right|.$$

Summing over $n \in \mathbb{Z}$ and using $\lim_{\nu \rightarrow \sigma} M_{\nu,A} = M_{\sigma,A}$ gives

$$\sum_{n \in \mathbb{Z}} \|\phi(2^n t A)x\| \leq \frac{K_{\sigma-\nu}}{\pi} M_{\sigma,A} \|\phi\|_{H^1(\Sigma_\sigma)} \|\zeta\|_{H^1(\Sigma_\sigma)} \|y\|,$$

where $K_\vartheta = (\frac{4}{\pi \log(2)} \vee \frac{2}{\pi \vartheta})^{1/p}$ is the constant of Proposition H.2.3 which we applied to the function $z \mapsto \phi(e^{\pm i\nu} z)$ on the sector $\Sigma_{\sigma-\nu}$.

Remark 10.4.3. The square function $\|x\|_{\phi,A}$ of Definition 10.4.1 was introduced using the dyadic points 2^n , $n \in \mathbb{Z}$. All results in this subsection easily remain true if the number 2 is replaced by any real number $q \in (1, \infty)$; the constants in the corresponding estimates will then also depend on the value of q .

The first main result of this section is the following square function bound for operators with a bounded H^∞ -calculus. Recall that the boundedness constant of the $H^\infty(\Sigma_\sigma)$ -calculus of an operator A is denoted by $M_{\sigma,A}^\infty$; this constant has been defined as the least admissible constant C in order that the inequality

$$\|f(A)x\| \leq C \|hf\|_{H^\infty(\Sigma_\sigma)} \|x\|$$

be satisfied for all $f \in H^\infty(\Sigma_\sigma)$ and $x \in \overline{D(A)} \cap R(A)$.

Theorem 10.4.4 (H^∞ -calculus implies square function bounds). *Let A be a sectorial operator with a bounded H^∞ -calculus on a Banach space X and let $\omega_{H^\infty}(A) < \sigma < \vartheta < \pi$. For all $\phi \in H^1(\Sigma_\vartheta)$ the following assertions hold:*

(1) *for all $x \in X$ we have*

$$\|x\|_{\phi,A} \leq K_{\vartheta-\sigma} M_{\sigma,A}^\infty \|\phi\|_{H^1(\Sigma_\vartheta)} \|x\|$$

(2) *if A is densely defined, then for all $x^* \in X^*$ we have*

$$\|x^*\|_{\phi,A^*} \leq K_{\vartheta-\sigma} M_{\sigma,A}^\infty \|\phi\|_{H^1(\Sigma_\vartheta)} \|x^*\|;$$

(3) *if A is densely defined and $\phi \neq 0$, then for all $x \in \overline{R(A)}$ we have*

$$\|x\| \leq K_{\vartheta-\sigma} M_{\sigma,A}^\infty C_\phi \|x\|_{\phi,A},$$

$$\text{where } C_\phi = \|\phi\|_{H^1(\Sigma_\vartheta)} / \|\phi\|_{L^2(\mathbb{R}_+, \frac{dt}{t})}^2.$$

Note that any function $\phi \in H^1(\Sigma_\vartheta)$ restricts to a function in $H^\infty(\Sigma_{\vartheta'})$ for all $0 < \vartheta' < \vartheta$ by Proposition H.2.4 and hence to a function in $H^2(\Sigma_{\vartheta'})$. In particular, $t \mapsto \phi(t)$ belongs $L^2(\mathbb{R}_+, \frac{dt}{t})$ (and is non-zero since ϕ is non-zero as a function in $H^1(\Sigma_\vartheta)$).

Proof. (1): By Lemma 10.3.8, for all $x \in X$ we have

$$\|x\|_{\phi,A} \leq \sup_{t>0} \sup_{N \geq 1} \sup_{|\epsilon_{-N}|, \dots, |\epsilon_N|=1} \left\| \sum_{|n| \leq N} \epsilon_n \phi(2^n t A)x \right\|$$

$$\leq K_{\vartheta-\sigma} M_{\sigma,A}^\infty \|\phi\|_{H^1(\Sigma_\vartheta)} \|x\|.$$

Taking $\epsilon = \epsilon(\omega)$ and averaging with respect to $\omega \in \Omega$ we obtain (1).

(2): This follows from the previous case applied to the adjoint operator A^* , which has an H^∞ -calculus by Proposition 10.2.20.

(3): Fix any $\omega_{H^\infty}(A) < \sigma < \vartheta < \pi$. Let $\psi \in H^1(\Sigma_\vartheta)$ be given by $\psi(z) := c_\phi^{-1} \overline{\phi(\bar{z})}$ with $c_\phi := \int_0^\infty |\phi(t)|^2 \frac{dt}{t}$. Analyticity of ψ follows by considering its Taylor series. For all $x \in D(A) \cap R(A)$ and $x^* \in X^*$, from the Calderón reproducing formula (Proposition 10.2.5) we obtain

$$\begin{aligned} |\langle x, x^* \rangle| &= \left| \int_0^\infty \langle \phi(tA) \psi(tA) x, x^* \rangle \frac{dt}{t} \right| \\ &= \left| \sum_{n \in \mathbb{Z}} \int_1^2 \langle \phi(2^n tA) \psi(2^n tA) x, x^* \rangle \frac{dt}{t} \right| \\ &\leq \liminf_{N \rightarrow \infty} \int_1^2 \left| \sum_{|n| \leq N} \langle \phi(2^n tA) \psi(2^n tA) x, x^* \rangle \right| \frac{dt}{t} \\ &\leq \sup_{N \geq 1} \sup_{t \in [1,2]} \left| \sum_{|n| \leq N} \langle \phi(2^n tA) \psi(2^n tA) x, x^* \rangle \right|. \end{aligned}$$

Randomising the sum in the last expression using a Rademacher sequence $(\varepsilon_n)_{n \in \mathbb{Z}}$ and noting that complex conjugate sequence $(\bar{\varepsilon}_n)_{n \in \mathbb{Z}}$ is a Rademacher sequence as well, we obtain

$$\begin{aligned} |\langle x, x^* \rangle| &\leq \sup_{N \geq 1} \sup_{t \in [1,2]} \left| \mathbb{E} \left\langle \sum_{|n| \leq N} \varepsilon_n \phi(2^n tA) x, \sum_{|n| \leq N} \bar{\varepsilon}_n \psi(2^n tA^*) x^* \right\rangle \right| \\ &\leq \|x\|_{\phi,A} \|x^*\|_{\psi,A} \\ &\leq K_{\vartheta-\sigma} M_{\sigma,A}^\infty c_\phi^{-1} \|\phi\|_{H^1(\Sigma_\vartheta)} \|x\|_{\phi,A} \|x^*\| \end{aligned}$$

by applying (2) in the last step. Taking the supremum over all $x^* \in X^*$ of norm ≤ 1 , we infer that

$$\|x\| \leq K_{\vartheta-\sigma} M_{\sigma,A}^\infty c_\phi^{-1} \|\phi\|_{H^1(\Sigma_\vartheta)} \|x\|_{\phi,A}.$$

This proves the desired bound for elements $x \in D(A) \cap R(A)$. By an approximating argument using (1) it follows that the estimate can be extended to $\overline{D(A) \cap R(A)} = \overline{R(A)}$ (by Proposition 10.1.8 and the assumption that $D(A)$ is dense in X). \square

Remark 10.4.5. Let A be a sectorial operator and consider a non-zero $\phi \in H^1(\Sigma_\vartheta)$, where $\omega(A) < \vartheta < \pi$. Inspecting the proof of Theorem 10.4.4, we see that its conclusions hold if we have

$$\sup_{t>0} \sup_{N \geq 1} \sup_{|\epsilon_{-N}|, \dots, |\epsilon_N|=1} \left\| \sum_{|n| \leq N} \epsilon_n \phi(2^n tA) \right\| < \infty.$$

Indeed, the assumption that A has a bounded H^∞ -calculus was only used to deduce this inequality via Lemma 10.3.8.

Our next aim is to prove a converse to Theorem 10.4.4: Theorem 10.4.9 below states that square function bounds together with R -sectoriality imply the boundedness of the H^∞ -calculus with $\omega_{H^\infty}(A) \leq \omega_R(A)$.

We need a preliminary result which allows us to compare the square functions $\|\cdot\|_{\phi,A}$ associated with different choices of ϕ . For the second part of the statement we recall from the discussion preceding Proposition 10.2.11 (see (10.14)) that for $x \in \mathbb{D}(A) \cap \mathbb{R}(A)$ and $f \in H^\infty(\Sigma_\sigma)$ one may define $f(A)x \in \overline{\mathbb{D}(A) \cap \mathbb{R}(A)}$ by regularisation with the function $\zeta(z) := z(1+z)^{-2}$ through

$$f(A)x := (f\zeta)(A)y$$

whenever $y \in X$ satisfies $\zeta(A)y = x$.

Recall the notation $M_{\sigma,A}^R$ for the R -bound of the set $\{zR(z,A) : |\arg(z)| < \sigma\}$.

Proposition 10.4.6 (Equivalence of discrete square functions). *Let A be an R -sectorial operator on a Banach space X and let $\omega_R(A) < \nu < \sigma < \pi$. Fix arbitrary $\phi, \psi \in H^1(\Sigma_\sigma)$ with $\psi \neq 0$. Then the following assertions hold:*

(1) *for all $f \in H^1(\Sigma_\sigma) \cap H^\infty(\Sigma_\sigma)$ and $x \in X$ we have*

$$\|f(A)x\|_{\phi,A} \leq C_{\phi,\psi} (M_{\sigma,A}^R)^2 \|f\|_{H^\infty(\Sigma_\sigma)} \|x\|_{\psi,A};$$

(2) *the same estimate holds for all $f \in H^\infty(\Sigma_\sigma)$ and $x \in \mathbb{D}(A) \cap \mathbb{R}(A)$, provided one interprets $f(A)x$ as explained above;*

(3) *if both ϕ and ψ are non-zero, then for all $x \in \mathbb{D}(A) \cap \mathbb{R}(A)$ we have an equivalence of homogeneous norms $\|x\|_{\phi,A} \approx \|x\|_{\psi,A}$, and moreover*

$$\|x\|_{\phi,A} \leq C_{\phi,\psi} (M_{\sigma,A}^R)^2 \|x\|_{\psi,A}.$$

The proof of Proposition 10.4.6 is based on following lemma. Recall that an operator-valued function is said to be *strongly measurable* if all of its orbits are strongly measurable.

Lemma 10.4.7. *Let $K, L : \mathbb{R}_+ \rightarrow \mathcal{L}(X)$ be bounded and strongly measurable functions and let $h \in L^1(\mathbb{R}_+, \frac{dt}{t})$. Assume that*

$$K(t)x = \int_0^\infty h(ts)L(s)x \frac{ds}{s}, \quad x \in X, t > 0. \quad (10.31)$$

Then for all $x \in X$ we have

$$\sup_{t>0} \sup_{N \geq 1} \mathbb{E} \left\| \sum_{|n| \leq N} \varepsilon_n K(2^n t)x \right\|^2 \leq \|h\|_{L^1(\mathbb{R}_+, \frac{dt}{t})}^2 \sup_{t>0} \sup_{N \geq 1} \mathbb{E} \left\| \sum_{|n| \leq N} \varepsilon_n L(2^n t)x \right\|^2.$$

Proof. In order to avoid convergence issues, we first replace h by $h_r := \mathbf{1}_{[r,1/r]}h$ and L by $L_r := \mathbf{1}_{[r,1/r]}L$ with $r \in (0, 1)$. Defining K_r as (10.31) with L replaced

by L_r , we have $K_r(t)x \rightarrow K(t)x$ for all $t \in (0, \infty)$ and $x \in X$. Moreover, for all $n \in \mathbb{Z}$ and $t > 0$,

$$K_r(2^n t)x = \int_1^2 \sum_{j \in \mathbb{Z}} h_r(2^{n+j}ts) L_r(2^j s)x \frac{ds}{s}.$$

By Kahane's contraction principle (see Theorem 6.1.13),

$$\begin{aligned} & \left\| \sum_{|n| \leq N} \varepsilon_n K_r(2^n t)x \right\|_{L^2(\Omega; X)} \\ & \leq \left\| \sum_{n \in \mathbb{Z}} \varepsilon_n K_r(2^n t)x \right\|_{L^2(\Omega; X)} \\ & \leq \int_1^2 \left\| \sum_{n \in \mathbb{Z}} \sum_{j \in \mathbb{Z}} \varepsilon_n h_r(2^{n+j}ts) L_r(2^j s)x \right\|_{L^2(\Omega; X)} \frac{ds}{s} \\ & = \int_1^2 \left\| \sum_{j \in \mathbb{Z}} \sum_{k \in \mathbb{Z}} \varepsilon_{k-j} h_r(2^k ts) L_r(2^j s)x \right\|_{L^2(\Omega; X)} \frac{ds}{s} \\ & \leq \sum_{k \in \mathbb{Z}} \int_1^2 \left\| \sum_{j \in \mathbb{Z}} \varepsilon_{k-j} h_r(2^k ts) L_r(2^j s)x \right\|_{L^2(\Omega; X)} \frac{ds}{s} \\ & \leq \sum_{k \in \mathbb{Z}} \int_1^2 |h_r(ts2^k)| \frac{ds}{s} \left(\sup_{s \in [1, 2]} \left\| \sum_{j \in \mathbb{Z}} \varepsilon_{k-j} L_r(2^j s)x \right\|_{L^2(\Omega; X)} \right) \\ & \leq \int_0^\infty |h(s)| \frac{ds}{s} \sup_{s \in [1, 2]} \sup_{N \geq 1} \left\| \sum_{|j| \leq N} \varepsilon_j L_r(2^j s)x \right\|_{L^2(\Omega; X)}. \end{aligned}$$

Again by the Kahane contraction principle,

$$\left\| \sum_{|j| \leq N} \varepsilon_j L_r(2^j s)x \right\|_{L^2(\Omega; X)} \leq \left\| \sum_{|j| \leq N} \varepsilon_j L(2^j s)x \right\|_{L^2(\Omega; X)}.$$

The assertion now follows by combining the estimates and letting $r \downarrow 0$. \square

Proof of Proposition 10.4.6. We only need to prove assertions (1) and (2), as (3) follows from (2) by taking $f \equiv 1$.

We present the proof for general $x \in X$ and functions $f \in H^1(\Sigma_\sigma) \cap H^\infty(\Sigma_\sigma)$; the reader may follow the lines of the proof to check that the same proof applied almost *verbatim* to the case where $x \in \mathbf{D}(A) \cap \mathbf{R}(A)$ and $f \in H^\infty(\Sigma_\sigma)$; the only difference is that the multiplicativity of the Dunford calculus in (10.32) must now be invoked with $f\zeta$ instead of f . This necessitates choosing $x \in \mathbf{D}(A) \cap \mathbf{R}(A)$.

Let $\xi \in H^1(\Sigma_\sigma) \cap H^\infty(\Sigma_\sigma)$ be an arbitrary non-zero function. Let $\eta \in H^1(\Sigma_\sigma)$ be defined by

$$\eta(z) := c_{\phi, \psi}^{-1} \overline{\psi(\bar{z}) \xi(\bar{z})}, \quad \text{where } c_{\phi, \psi} := \int_0^\infty |\psi(t)|^2 |\xi(t)|^2 \frac{dt}{t},$$

so that $\int_0^\infty \xi(t)\eta(t)\psi(t) \frac{dt}{t} = 1$ (the integral defining $c_{\phi,\psi}$ is finite by an argument similar to the one in the proof of Theorem 10.4.4. Analyticity of η follows by considering its Taylor series. Then

$$\int_0^\infty \xi(tz)\eta(tz)\psi(tz) \frac{dt}{t} = 1, \quad z \in \Sigma_\sigma,$$

which is clear for $z \in \mathbb{R} \setminus \{0\}$ and then in general by analytic continuation.

Let $f \in H^1(\Sigma_\sigma) \cap H^\infty(\Sigma_\sigma)$. By Fubini's theorem and the multiplicativity of the Dunford calculus

$$\begin{aligned} f(A) &= \frac{1}{2\pi i} \int_{\partial\Sigma_\nu} f(z)R(z, A) dz \\ &= \frac{1}{2\pi i} \int_0^\infty \int_{\partial\Sigma_\nu} f(z)\xi(tz)\eta(tz)\psi(tz)R(z, A) dz \frac{dt}{t} \\ &= \int_0^\infty f(A)\xi(tA)\eta(tA)\psi(tA) \frac{dt}{t}. \end{aligned} \quad (10.32)$$

For $z \in \Sigma_\sigma$ set

$$U(z) := \int_0^\infty \xi(tz)f(A)\eta(tA)\psi(tA) \frac{dt}{t}, \quad L(z) := zR(z, A)U(z).$$

An easy estimate using (10.9) shows that the operators $U(z)$ thus defined are uniformly bounded, and by Fubini's theorem

$$\begin{aligned} f(A)\phi(sA)x &= \int_0^\infty f(A)\xi(tA)\eta(tA)\psi(tA)\phi(sA)x \frac{dt}{t} \\ &= \int_0^\infty \left(\frac{1}{2\pi i} \int_{\partial\Sigma_\nu} \xi(tz)\phi(sz)R(z, A) dz \right) f(A)\eta(tA)\psi(tA)x \frac{dt}{t} \\ &= \frac{1}{2\pi i} \int_{\partial\Sigma_\nu} \phi(sz)R(z, A) \left(\int_0^\infty \xi(tz)f(A)\eta(tA)\psi(tA)x \frac{dt}{t} \right) dz \\ &= \frac{1}{2\pi i} \int_{\partial\Sigma_\nu} \phi(sz)R(z, A)U(z)x dz \\ &= \frac{1}{2\pi i} \sum_{\epsilon=\pm 1} \int_0^\infty \epsilon\phi(e^{-i\epsilon\nu st})L(e^{-i\epsilon\nu t})x \frac{dt}{t} \\ &= \frac{1}{2\pi i} \sum_{\epsilon=\pm 1} \int_0^\infty \epsilon\phi(e^{-i\epsilon\nu t})L(e^{-i\epsilon\nu s^{-1}t})x \frac{dt}{t}. \end{aligned} \quad (10.33)$$

Hence by Lemma 10.4.7,

$$\begin{aligned} \|f(A)x\|_{\phi, A} &= \sup_{t>0} \sup_{N \geq 1} \left\| \sum_{|n| \leq N} \varepsilon_n f(A)\phi(2^n tA)x \right\|_{L^2(\Omega; X)} \end{aligned}$$

$$\begin{aligned}
&\leq \frac{1}{\pi} \|\phi\|_{H^1(\Sigma_\sigma)} \sup_{\epsilon \in \{-1,1\}} \sup_{t>0} \sup_{N \geq 1} \left\| \sum_{|n| \leq N} \varepsilon_n L(e^{-i\epsilon\nu} 2^n t) x \right\|_{L^2(\Omega; X)} \\
&\leq \frac{1}{\pi} \|\phi\|_{H^1(\Sigma_\sigma)} M_{\nu, A}^R \sup_{\epsilon \in \{-1,1\}} \sup_{t>0} \sup_{N \geq 1} \left\| \sum_{|n| \leq N} \varepsilon_n U(e^{-i\epsilon\nu} 2^n t) x \right\|_{L^2(\Omega; X)}.
\end{aligned}$$

By another application of Lemma 10.4.7,

$$\begin{aligned}
&\sup_{t>0} \sup_{N \geq 1} \left\| \sum_{|n| \leq N} \varepsilon_n U(e^{-i\epsilon\nu} 2^n t) x \right\|_{L^2(\Omega; X)} \\
&= \sup_{t>0} \sup_{N \geq 1} \left\| \sum_{|n| \leq N} \varepsilon_n \int_0^\infty \xi(e^{-i\epsilon\nu} 2^n s t) f(A) \eta(sA) \psi(sA) x \frac{ds}{s} \right\|_{L^2(\Omega; X)} \\
&= \sup_{t>0} \sup_{N \geq 1} \left\| \sum_{|n| \leq N} \varepsilon_n \int_0^\infty \xi(e^{-i\epsilon\nu} s t) f(A) \eta(2^{-n} sA) \psi(2^{-n} sA) x \frac{ds}{s} \right\|_{L^2(\Omega; X)} \\
&\leq \|\xi\|_{H^1(\Sigma_\sigma)} \sup_{t>0} \sup_{N \geq 1} \left\| \sum_{|m| \leq N} \varepsilon_m f(A) \eta(2^m tA) \psi(2^m tA) x \right\|_{L^2(\Omega; X)} \\
&\leq \|\xi\|_{H^1(\Sigma_\sigma)} \sup_{t>0} \mathcal{R}(\{f(A) \eta(2^m tA) : m \in \mathbb{Z}\}) \|x\|_{\psi, A}.
\end{aligned}$$

To estimate the R -bound uniformly in $t > 0$ we invoke Proposition 10.3.2, taking into account the estimate

$$\sup_{t>0} \int_{\partial\Sigma_\nu} |f(z)| |\eta(tz)| \left| \frac{dz}{z} \right| \leq c_{\phi, \psi}^{-1} \|f\|_{H^\infty(\Sigma_\sigma)} \|\xi\psi\|_{H^1(\Sigma_\sigma)}. \quad (10.34)$$

This gives the desired R -boundedness, with estimate

$$\mathcal{R}(\{f(A) \eta(2^m tA) : m \in \mathbb{Z}\}) \leq \frac{1}{\pi} M_{\sigma, A}^R c_{\phi, \psi}^{-1} \|f\|_{H^\infty(\Sigma_\sigma)} \|\xi\psi\|_{H^1(\Sigma_\sigma)}.$$

Putting together all the estimates we obtain part (1) with

$$C_{\phi, \psi} = \frac{1}{\pi^2} \|\phi\|_{H^1(\Sigma_\sigma)} \|\xi\|_{H^1(\Sigma_\sigma)} \|\xi\psi\|_{H^1(\Sigma_\sigma)} \|\xi\psi\|_{L^2(\mathbb{R}_+, \frac{dt}{t})}^{-2}. \quad (10.35)$$

□

As a first application we now show that the supremum over t in the definition of the discrete square function norm $\|\cdot\|_{\phi, A}$ can be eliminated under suitable assumptions on ϕ and A .

Proposition 10.4.8. *Let A be an R -sectorial operator, let $\omega_R(A) < \sigma < \pi$, and let $\phi \in H^1(\Sigma_\sigma) \cap H^2(\Sigma_\sigma)$ be a zero-free function with the property that the functions*

$$\psi_t(z) = \frac{\phi^2(tz)}{\phi(z)}, \quad t > 0,$$

satisfy

$$\sup_{t \in [1, 2]} \|\psi_t\|_{H^1(\Sigma_\nu)} < \infty.$$

Then for all $x \in \mathcal{D}(A) \cap \mathcal{R}(A)$ we have an equivalence of norms

$$\|x\|_{\phi, A} \approx \sup_{N \geq 1} \left(\mathbb{E} \left\| \sum_{|n| \leq N} \varepsilon_n \phi(2^n A)x \right\|^2 \right)^{1/2}$$

with constants independent of x . This proves the upper bound in (10.35). The lower bound (with constant 1) holds trivially.

It is easy to check that the condition on the ψ_t 's is satisfied for common choices such as $\phi(z) = z^\alpha e^{-z}$ and $\phi(z) = z^\alpha / (1+z)^\beta$ for $0 < \alpha < \beta$.

Proof. We apply Proposition 10.3.2, which gives us

$$\mathcal{R}(\{\psi_t(2^n A) : n \in \mathbb{Z}, t \in [1, 2]\}) \leq \frac{1}{\pi} M_{\sigma, A}^R \sup_{t \in [1, 2]} \|\psi_t\|_{H^1(\Sigma_\nu)} =: K.$$

For $x \in \mathcal{D}(A) \cap \mathcal{R}(A)$, by Proposition 10.4.6(3), with $C = (M_{\nu, A}^R)^2 C_{\phi, \xi}$ we obtain

$$\begin{aligned} \|x\|_{\phi, A} &\leq C \|x\|_{\phi^2, A} = C \sup_{t \in [1, 2]} \sup_{N \geq 1} \left(\mathbb{E} \left\| \sum_{|n| \leq N} \varepsilon_n \phi^2(2^n t A)x \right\|^2 \right)^{1/2} \\ &= C \sup_{s \in [1, 2]} \sup_{N \geq 1} \left(\mathbb{E} \left\| \sum_{|n| \leq N} \varepsilon_n \psi_t^2(2^n A) \phi(2^n A)x \right\|^2 \right)^{1/2} \\ &\leq CK \sup_{N \geq 1} \left(\mathbb{E} \left\| \sum_{|n| \leq N} \varepsilon_n \phi(2^n A)x \right\|^2 \right)^{1/2}. \end{aligned}$$

□

Theorem 10.4.4 admits the following converse:

Theorem 10.4.9 (Square function bounds imply H^∞ -calculus). *Let A be an R -sectorial operator on a Banach space X . If, for some non-zero $\phi, \psi \in H^1(\Sigma_\sigma)$ with $\omega_R(A) < \sigma < \pi$, there exist constants $c_0, c_1 > 0$ such that*

$$\|x\| \leq c_0 \|x\|_{\phi, A}, \quad \text{and} \quad \|x\|_{\psi, A} \leq c_1 \|x\|, \quad x \in \mathcal{D}(A) \cap \mathcal{R}(A),$$

then A has a bounded $H^\infty(\Sigma_\sigma)$ -calculus. In particular,

$$\omega_{H^\infty}(A) \leq \omega_R(A).$$

Proof. For $f \in H^1(\Sigma_\sigma) \cap H^\infty(\Sigma_\sigma)$ and $x \in D(A) \cap R(A)$, from our assumption and Proposition 10.4.6 we infer that

$$\begin{aligned} \|f(A)x\| &\leq c_0 \|f(A)x\|_{\phi,A} \\ &\leq c_0 C_{\phi,\psi} (M_{\sigma,A}^R)^2 \|f\|_{H^\infty(\Sigma_\sigma)} \|x\|_{\psi,A} \\ &\leq c_0 c_1 C_{\phi,\psi} (M_{\sigma,A}^R)^2 \|f\|_{H^\infty(\Sigma_\sigma)} \|x\|, \end{aligned}$$

where $C_{\phi,\psi}$ is as in Proposition 10.4.6. This proves the result, with bound $M_{\sigma,A}^\infty \leq c_0 c_1 C_{\phi,\psi} (M_{\sigma,A}^R)^2$. \square

Corollary 10.4.10. *Let A be a densely defined sectorial operator with a bounded H^∞ -calculus on a Banach space X with the triangular contraction property. Then A is R -sectorial and*

$$\omega_{H^\infty}(A) = \omega_R(A) = \omega_\gamma(A).$$

Proof. By Theorem 10.3.4(2), A is R -sectorial and $\omega_R(A) \leq \omega_{H^\infty}(A)$. Furthermore, since the triangular contraction property implies finite cotype (Corollary 7.5.13), A is γ -sectorial with $\omega_R(A) = \omega_\gamma(A)$ by the equivalence of R -boundedness and γ -boundedness in such spaces (Theorem 8.1.3. The converse estimate $\omega_{H^\infty}(A) \leq \omega_R(A)$ has been proved in Theorem 10.4.9. \square

The following converse to Lemma 10.3.8 once more expresses the close connection between the H^∞ -calculus and unconditional convergence of the “parts” $\phi(2^n A)$.

Proposition 10.4.11. *Let A be a densely defined R -sectorial operator on a Banach space X and let $\omega_R(A) < \vartheta < \pi$. If, for some non-zero $\phi \in H^1(\Sigma_\vartheta)$,*

$$\sup_{t>0} \sup_{N \geq 1} \sup_{|\epsilon_{-N}|, \dots, |\epsilon_N|=1} \left\| \sum_{|n| \leq N} \epsilon_n \phi(2^n tA) \right\| < \infty,$$

then A has a bounded $H^\infty(\Sigma_\sigma)$ -calculus for any $\sigma \in (\omega_R(A), \pi)$.

Proof. By Remark 10.4.5, the square function estimates of Theorem 10.4.4 hold. It thus follows from Theorem 10.4.9 that A has a bounded $H^\infty(\Sigma_\sigma)$ -calculus for all $\omega_R(A) < \sigma < \pi$. \square

10.4.b Continuous square functions

We now turn to continuous analogues of the preceding discrete square function results. After some preliminary considerations on continuous square functions, our first aim is to obtain a continuous analogue of Theorem 10.4.4: Boundedness of the H^∞ -calculus implies boundedness of continuous square functions.

Definition 10.4.12 (Continuous square functions). *Let A be a sectorial operator on a Banach space X and let $\omega(A) < \sigma < \pi$. The continuous square function norm of a vector $x \in X$ associated with a function $\phi \in H^1(\Sigma_\sigma)$ is defined by*

$$\|x\|_{\phi,A} := \left\| t \mapsto \phi(tA)x \right\|_{\gamma(\mathbb{R}_+, \frac{dt}{t}; X)}$$

whenever $t \mapsto \phi(tA)x$ belongs to $\gamma(\mathbb{R}_+, \frac{dt}{t}; X)$.

In order to state our results in their strongest possible form we will also need dual square functions. In order to introduce these we use the following terminology. For a measure space (S, Σ, μ) and a strongly μ -measurable function $g : S \rightarrow X^*$ we say that g belongs to $\gamma^*(S; X^*)$ if

$$\|g\|_{\gamma^*(S; X^*)} := \sup_{\substack{f \in \gamma(S; X) \\ \|f\|_{\gamma(S; X)} \leq 1}} \left| \int_S \langle f(s), g(s) \rangle d\mu(s) \right| < \infty,$$

the supremum being taken over all strongly measurable functions that are weakly square integrable and belong to $\gamma(S; X)$. By density it suffices to consider simple functions in the supremum.

Definition 10.4.13 (Continuous dual square functions). *Let A be a densely defined sectorial operator on a Banach space X and let $\omega(A) < \sigma < \pi$. The continuous dual square function norm of a vector $x^* \in X^*$ associated with a function $\phi \in H^1(\Sigma_\sigma)$ and A is defined by*

$$\|x^*\|_{\phi, A^*}^* := \left\| t \mapsto \phi(tA^*)x^* \right\|_{\gamma^*(\mathbb{R}_+, \frac{dt}{t}; X^*)}$$

whenever $t \mapsto \phi(tA^*)x^*$ belongs to $\gamma^*(\mathbb{R}_+, \frac{dt}{t}; X^*)$.

Typical choices in applications include

$$\begin{aligned} \phi(z) &= z^\alpha(1+z)^{-\beta}, & \phi(tA) &= (tA)^\alpha(I+tA)^{-\beta}; \\ \phi(z) &= z^\alpha \exp(-z), & \phi(tA) &= (tA)^\alpha \exp(-tA), \end{aligned}$$

where $0 < \alpha < \beta$. For the negative Laplace operator $A = -\Delta$ on $X = L^p(\mathbb{R}^d)$, $1 < p < \infty$, the choice $\phi_k(z) = z^k \exp(-z)$ leads to a continuous square function norm equivalent to the classical Littlewood-Paley g -function norm of (10.30). To see this, recall that the radonifying norm in $L^p(\mathbb{R}^d)$ -space can be computed using Proposition 9.3.2. Then

$$\begin{aligned} \left\| \left(\int_0^\infty \left| t^k \frac{d^k}{dt^k} e^{-t\Delta} f \right|^2 \frac{dt}{t} \right)^{1/2} \right\|_p &\approx_p \left\| t \mapsto t^k \frac{d^k}{dt^k} e^{-t\Delta} f \right\|_{\gamma(\mathbb{R}_+, \frac{dt}{t}; L^p(\mathbb{R}^d))} \\ &= \left\| t \mapsto t^k (-\Delta)^k e^{-t\Delta} f \right\|_{\gamma(\mathbb{R}_+, \frac{dt}{t}; L^p(\mathbb{R}^d))} \\ &= \left\| t \mapsto \phi_k(tA)f \right\|_{\gamma(\mathbb{R}_+, \frac{dt}{t}; L^p(\mathbb{R}^d))}. \end{aligned}$$

We point out that the definition of continuous square functions is phrased in terms of membership of the space $\gamma(\mathbb{R}_+, \frac{dt}{t}; X)$. This space should be carefully distinguished from its larger variant $\gamma_\infty(\mathbb{R}_+, \frac{dt}{t}; X)$. In most applications X has finite cotype or is even a UMD space, and in such cases both spaces are equal, with identical norms, by Theorem 9.1.20. In the case of a general Banach space X , however, one must carefully distinguish between these spaces. One of our main tools in the analysis of continuous square functions is the γ -multiplier theorem, Theorem 9.5.1, which asserts that γ -bounded pointwise multipliers act boundedly from $\gamma(\mathbb{R}_+, \frac{dt}{t}; X)$ into $\gamma_\infty(\mathbb{R}_+, \frac{dt}{t}; X)$. This is only a minor inconvenience in the case of square functions, thanks to the following useful observation.

Lemma 10.4.14. *Let A be a sectorial operator on a Banach space X and let $\omega(A) < \sigma < \pi$. Then for all $\phi \in H^1(\Sigma_\sigma)$ and $x \in \mathcal{D}(A) \cap \mathcal{R}(A)$ the function $t \mapsto \phi(tA)x$ defines an element of $\gamma(\mathbb{R}_+, \frac{dt}{t}; X)$.*

Proof. Fix an $x \in \mathcal{D}(A) \cap \mathcal{R}(A)$, say $x = \zeta(A)y$ with $\zeta(z) = z(1+z)^{-2}$. With $\omega(A) < \nu < \sigma$, the Dunford calculus gives

$$\phi(tA)x = \frac{1}{2\pi i} \int_{\partial\Sigma_\nu} \phi(tz)\zeta(z)R(z, A)y \, dz.$$

As it was already observed before (see the discussion around Theorem 10.4.4), Proposition H.2.4 implies that $t \mapsto \phi(tz)$ belongs to $L^2(\mathbb{R}_+, \frac{dt}{t})$. Then for each $x_0 \in X$ the function $t \mapsto \phi(tz) \otimes x_0$ belongs to $\gamma(\mathbb{R}_+, \frac{dt}{t}; X)$ and by Proposition 9.1.3 its norm is given by

$$\|t \mapsto \phi(tz) \otimes x_0\|_{\gamma(\mathbb{R}_+, \frac{dt}{t}; X)} = \|t \mapsto \phi(tz)\|_{L^2(\mathbb{R}_+, \frac{dt}{t}; X)} \|x_0\|.$$

Applying this with $x_0 = x_0(z) = R(z, A)y$, we may interpret the above Dunford integral as a Bochner integral in $\gamma(\mathbb{R}_+, \frac{dt}{t}; X)$. This shows that $t \mapsto \phi(tA)x \in \gamma(\mathbb{R}_+, \frac{dt}{t}; X)$ and

$$\begin{aligned} & \|t \mapsto \phi(tA)x\|_{\gamma(\mathbb{R}_+, \frac{dt}{t}; X)} \\ & \leq \frac{1}{2\pi} \int_{\partial\Sigma_\nu} \|t \mapsto \phi(tz)\zeta(z)R(z, A)y\|_{\gamma(\mathbb{R}_+, \frac{dt}{t}; X)} |dz| \\ & \leq \frac{M_{\nu, A}}{2\pi} \int_{\partial\Sigma_\nu} \|t \mapsto \phi(tz)\|_{L^2(\mathbb{R}_+, \frac{dt}{t})} |\zeta(z)| \|y\| \left| \frac{dz}{z} \right| \\ & \leq \frac{M_{\nu, A}}{\pi} \|\phi\|_{H^2(\Sigma_\sigma)} \|\zeta\|_{H^1(\Sigma_\sigma)} \|y\|. \end{aligned}$$

□

Our first result relating discrete and continuous square functions is as follows. A further comparison will be given in Proposition 10.4.20.

Proposition 10.4.15. *Let A be a sectorial operator on a Banach space X and let $\omega(A) < \sigma < \pi$. For $\phi \in H^1(\Sigma_\sigma)$ and $0 < \delta < \omega(A) - \sigma$ set $\phi_{\pm\delta}(z) = \phi(e^{\pm i\delta}z)$. Then,*

(1) *without any additional assumptions, for all $x \in \mathbf{D}(A) \cap \mathbf{R}(A)$ we have*

$$\|x\|_{\phi,A} \lesssim_\delta (\|x\|_{\phi_{-\delta},A} + \|x\|_{\phi_\delta,A});$$

(2) *if X has finite cotype, then for all $x \in \mathbf{D}(A) \cap \mathbf{R}(A)$ we have*

$$\|x\|_{\phi,A} \lesssim_\delta C_X \sup_{|\beta| < \delta} \|x\|_{\phi_\beta,A};$$

(3) *if A is densely defined, then for all $x^* \in \mathbf{D}(A^*) \cap \mathbf{R}(A^*)$ we have*

$$\|x^*\|_{\phi,A^*}^* \lesssim_\delta \sup_{|\beta| < \delta} \|x^*\|_{\phi_\beta,A^*}.$$

Proof. (1): We have

$$\begin{aligned} \|x\|_{\phi,A} &= \sup_{t \in [1,2]} \sup_{N \geq 1} \left\| \sum_{|n| \leq N} \varepsilon_n \phi(2^n t A) x \right\|_{L^2(\Omega; X)} \\ &\leq \frac{1}{\|\gamma\|_1} \sup_{t \in [1,2]} \sup_{N \geq 1} \left\| \sum_{|n| \leq N} \gamma_n \phi(2^n t A) x \right\|_{L^2(\Omega; X)} \\ &\lesssim_\delta (\|x\|_{\phi_{-\delta},A} + \|x\|_{\phi_\delta,A}), \end{aligned}$$

where the last estimate follows from the sectorial version of Lemma 9.7.10.

(2): By the sectorial version of Proposition 9.7.20 we obtain

$$\begin{aligned} \|x\|_{\phi,A} &\lesssim_\delta \sup_{|\beta| < \delta} \sup_{t \in [1,2]} \sup_{N \geq 1} \left\| \sum_{|n| \leq N} \gamma_n \phi(t 2^n e^{i\beta} A) x \right\|_{L^2(\Omega; X)} \\ &\lesssim_\delta C_X \sup_{|\beta| < \delta} \sup_{t \in [1,2]} \sup_{N \geq 1} \left\| \sum_{|n| \leq N} \varepsilon_n \phi(t 2^n e^{i\beta} A) x \right\|_{L^2(\Omega; X)} \\ &= C_X \sup_{|\beta| < \delta} \|x\|_{\phi_\beta,A}, \end{aligned}$$

where in the second step we applied the finite cotype of X to estimate the Gaussian sequence by a Rademacher sequence (see Corollary 7.2.10).

(3): By the sectorial version of Proposition 9.7.19,

$$\begin{aligned} \|x^*\|_{\phi,A^*}^* &\lesssim_\delta \sup_{|\beta| < \delta} \sup_{t \in [1,2]} \sup_{N \geq 1} \left\| \sum_{|n| \leq N} \varepsilon_n \phi(t 2^n e^{i\beta} A^*) x^* \right\|_{L^2(\Omega; X^*)} \\ &= \sup_{|\beta| < \delta} \|x^*\|_{\phi_\beta,A^*}^*. \end{aligned}$$

□

We can now prove the following continuous analogue of Theorem 10.4.4.

Theorem 10.4.16 (H^∞ -calculus implies square function bounds). *Let A be a sectorial operator with a bounded $H^\infty(\Sigma_\sigma)$ -calculus on a Banach space X with finite cotype, and let $\omega_{H^\infty}(A) < \sigma < \vartheta < \pi$. Let $\phi \in H^1(\Sigma_\vartheta)$.*

(1) *If X has finite cotype, then for all $x \in \overline{D(A) \cap R(A)}$ we have*

$$\|t \mapsto \phi(tA)x\|_{\gamma(\mathbb{R}_+, \frac{dt}{t}; X)} \leq C_{\vartheta, \sigma} C_X M_{\sigma, A}^\infty \|\phi\|_{H^1(\Sigma_\vartheta)} \|x\|.$$

(2) *If A is densely defined, then for all $x^* \in \overline{D(A^*) \cap R(A^*)}$,*

$$\|t \mapsto \phi(tA^*)x^*\|_{\gamma^*(\mathbb{R}_+, \frac{dt}{t}; X^*)} \leq C_{\vartheta, \sigma} M_{\sigma, A}^\infty \|\phi\|_{H^1(\Sigma_\vartheta)} \|x^*\|.$$

(3) *If A is densely defined and $\phi \neq 0$, then for all $x \in D(A) \cap R(A)$ we have*

$$\|x\| \leq C_{\vartheta, \sigma} C_\phi M_{\sigma, A}^\infty M_{\sigma, A} \|t \mapsto \phi(tA)x\|_{\gamma(\mathbb{R}_+, \frac{dt}{t}; X)},$$

$$\text{where } C_\phi = \|\phi\|_{H^1(\Sigma_\vartheta)} \|\phi\|_{L^2(\mathbb{R}_+, \frac{dt}{t})}^{-2}.$$

In all three parts, membership of $t \mapsto \phi(tA)x$ of the respective spaces is part of the assertion.

Proof. (1): By density it suffices to consider $x \in D(A) \cap R(A)$. Let $\delta > 0$ be such that $\vartheta - \delta > \sigma$ (for instance $\delta = (\vartheta - \sigma)/2$). Since by Proposition 10.4.15(2),

$$\|x\|_{\phi, A} \lesssim_\delta C_X \sup_{|\beta| < \delta} \|x\|_{\phi_\beta, A},$$

it suffices to estimate $\|x\|_{\phi_\beta, A}$ uniformly for $|\beta| < \delta$. Since

$$\|\phi_\beta\|_{H^1(\Sigma_{\vartheta-\delta})} \leq \|\phi\|_{H^1(\Sigma_\vartheta)},$$

it follows from Theorem 10.4.4(1) that

$$\|x\|_{\phi_\beta, A} \lesssim_{\sigma, \vartheta} M_{\sigma, A}^\infty \|\phi\|_{H^1(\Sigma_\vartheta)} \|x\|$$

with a constant depending on σ, ϑ but independent of β .

(2): This can be proved in the same way by using Proposition 10.4.15(3) and Theorem 10.4.4(2) instead.

(3): Since we take $x \in D(A) \cap R(A)$, Lemma 10.4.14 guarantees that $\phi(tA)x \in \gamma(\mathbb{R}_+, \frac{dt}{t}; X)$. Let $\psi \in H^1(\Sigma_\vartheta)$ be given by $\psi(z) = c^{-1} \overline{\phi(\bar{z})}$ with $c = \int_0^\infty |\phi(t)|^2 \frac{dt}{t}$. For all $x^* \in D(A^*) \cap R(A^*)$, from the reproducing formula of Proposition 10.2.5 we obtain

$$|\langle x, x^* \rangle| = \left| \int_0^\infty \langle \phi(tA)\psi(tA)x, x^* \rangle \frac{dt}{t} \right|$$

$$\leq \left\| t \mapsto \phi(tA)x \right\|_{\gamma(\mathbb{R}_+, \frac{dt}{t}; X)} \left\| t \mapsto \psi(tA)^* x^* \right\|_{\gamma^*(\mathbb{R}_+, \frac{dt}{t}; X^*)}.$$

By (2),

$$\|\psi(tA)^* x^*\|_{\gamma^*(\mathbb{R}_+, \frac{dt}{t}; X^*)} \leq C_{\vartheta, \sigma} M_{\sigma, A}^\infty \|\phi\|_{H^1(\Sigma_\vartheta)} \|x^*\|.$$

Therefore,

$$|\langle x, x^* \rangle| \leq C_{\vartheta, \sigma} M_{\sigma, A}^\infty c^{-1} \|\phi\|_{H^1(\Sigma_\vartheta)} \|x\|_{\phi, A} \|x^*\|.$$

Taking the supremum over all $x^* \in \mathbf{D}(A^*) \cap \mathbf{R}(A^*)$ of norm ≤ 1 , from Lemma 10.2.19 we infer

$$\|x\| \leq 2C_{\vartheta, \sigma} M_{\sigma, A} M_{\sigma, A}^\infty c^{-1} \|\phi\|_{H^1(\Sigma_\vartheta)} \|x\|_{\phi, A}.$$

□

Our next aim is to prove that boundedness of continuous square functions implies the boundedness of the H^∞ -calculus. Here we will follow the same strategy as in the discrete setting. The following result is the continuous analogue of Proposition 10.4.6.

Let $M_{\sigma, A}^\gamma$ denote the γ -bound of the set $\{zR(z, A) : z \in \overline{\mathbb{C} \setminus \Sigma_\nu}\}$.

Proposition 10.4.17 (Equivalence of continuous square functions).

Let A be a γ -sectorial operator on X and let $\omega_\gamma(A) < \nu < \sigma < \pi$. Fix arbitrary $\phi, \psi \in H^1(\Sigma_\sigma)$, with $\psi \neq 0$. Then the following assertions hold:

(1) for all $f \in H^1(\Sigma_\sigma) \cap H^\infty(\Sigma_\sigma)$ and $x \in \mathbf{D}(A) \cap \mathbf{R}(A)$ we have

$$\|f(A)\phi(\cdot A)x\|_{\gamma(\mathbb{R}_+, \frac{dt}{t}; X)} \leq C_{\phi, \psi} (M_{\sigma, A}^\gamma)^2 \|f\|_{H^\infty(\Sigma_\sigma)} \|\psi(\cdot A)x\|_{\gamma(\mathbb{R}_+, \frac{dt}{t}; X)}.$$

(2) if both ϕ and ψ are non-zero, then for all $x \in \mathbf{D}(A) \cap \mathbf{R}(A)$ we have an equivalence of norms

$$\|\phi(tA)x\|_{\gamma(L^2(\mathbb{R}_+, \frac{dt}{t}), X)} \approx \|\psi(tA)x\|_{\gamma(L^2(\mathbb{R}_+, \frac{dt}{t}), X)}$$

with constants independent of x .

In the proof we use the following lemma.

Lemma 10.4.18. For any $h \in L^1(\mathbb{R}_+, \frac{dt}{t})$, the operator S_h on $L^2(\mathbb{R}_+, \frac{dt}{t}) \otimes X$ defined by

$$S_h(u \otimes x)(s) := \left(\int_0^\infty h(st)u(t) \frac{dt}{t} \right) \otimes x, \quad s > 0,$$

extends uniquely to a bounded operator on $\gamma(\mathbb{R}_+, \frac{dt}{t}; X)$ of norm $\|S_h\| \leq \|h\|_{L^1(\mathbb{R}_+, \frac{dt}{t})}$.

Proof. By Theorem 9.6.1 it suffices to show that $u \mapsto \int_0^\infty h(t)u(t) \frac{dt}{t}$ defines a bounded operator on $L^2(\mathbb{R}_+, \frac{dt}{t})$. Let $c = \|h\|_{L^1(\mathbb{R}_+, \frac{dt}{t})}$. By Jensen's inequality and Fubini's theorem, for all $u \in L^2(\mathbb{R}_+, \frac{dt}{t})$ we have

$$\int_0^\infty \left| \int_0^\infty h(st)u(t) \frac{dt}{ct} \right|^2 \frac{ds}{s} \leq \int_0^\infty \int_0^\infty |h(st)| |u(t)|^2 \frac{dt}{ct} \frac{ds}{s} = \int_0^\infty |u(t)|^2 \frac{dt}{t}.$$

This gives the result. \square

Proof of Proposition 10.4.17. As in the discrete case we only need to prove assertion (1). Since $x \in \mathcal{D}(A) \cap \mathcal{R}(A)$, all square functions are well defined by Lemma 10.4.14. It was shown in the proof of Proposition 10.4.6 (see (10.33)), using the same notation introduced there, that

$$\begin{aligned} f(A)\phi(sA) &= \frac{1}{2\pi i} \int_{\partial\Sigma_\nu} \phi(sz)R(z, A)U(z) dz \\ &= \frac{1}{2\pi i} \sum_{\epsilon=\pm 1} \int_0^\infty \epsilon \phi(ste^{-i\epsilon\nu})te^{-i\epsilon\nu} R(te^{-i\epsilon\nu}, A)U(te^{-i\epsilon\nu}) \frac{dt}{t}. \end{aligned}$$

Using Lemma 10.4.18, the γ -multiplier theorem (Theorem 9.5.1 applied in combination with Lemma 10.4.14), the γ -sectoriality of A , and Lemma 10.4.18 once again, we obtain

$$\begin{aligned} \|t \mapsto f(A)\phi(tA)x\|_{\gamma(\mathbb{R}_+, \frac{dt}{t}; X)} &\leq \frac{1}{\pi} \|\phi\|_{H^1(\Sigma_\sigma)} \sup_{\epsilon \in \{-1, 1\}} \|t \mapsto tR(te^{i\epsilon\nu}, A)U(te^{i\epsilon\nu})x\|_{\gamma(\mathbb{R}_+, \frac{dt}{t}; X)} \\ &\leq \frac{1}{\pi} M_{\nu, A}^\gamma \|\phi\|_{H^1(\Sigma_\sigma)} \sup_{\epsilon \in \{-1, 1\}} \|t \mapsto U(te^{i\epsilon\nu})x\|_{\gamma(\mathbb{R}_+, \frac{dt}{t}; X)} \\ &\leq \frac{1}{\pi} M_{\nu, A}^\gamma \|\phi\|_{H^1(\Sigma_\sigma)} \|\xi\|_{H^1(\Sigma_\sigma)} \|t \mapsto f(A)\eta(tA)\psi(tA)x\|_{\gamma(\mathbb{R}_+, \frac{dt}{t}; X)}. \end{aligned}$$

In view of the γ -multiplier theorem, it remains to be shown that $\{f(A)\eta(tA) : t > 0\}$ is γ -bounded. But this follows from the analogue of Proposition 10.3.2 for γ -boundedness, taking into account the estimate (10.34). The γ -multiplier theorem applied in combination with Lemma 10.4.14, now gives

$$\begin{aligned} \|t \mapsto f(A)\eta(tA)\psi(tA)x\|_{\gamma(\mathbb{R}_+, \frac{dt}{t}; X)} &\leq \frac{1}{\pi} (M_{\nu, A}^\gamma)^2 \|f\|_{H^\infty(\Sigma_\sigma)} \|\phi\|_{H^1(\Sigma_\sigma)} \|\xi\psi\|_{H^1(\Sigma_\sigma)} \|t \mapsto \psi(tA)x\|_{\gamma(\mathbb{R}_+, \frac{dt}{t}; X)}. \end{aligned}$$

After letting $\nu \uparrow \sigma$, this proves (1) with constant $C_{\phi, \psi}$ as in (10.35). \square

The next result is a continuous time version of Theorem 10.4.9 and a converse to Theorem 10.4.16.

Theorem 10.4.19 (Square function bounds imply H^∞ -calculus). *Let A be a γ -sectorial operator on a Banach space X . If, for some non-zero $\phi, \psi \in H^1(\Sigma_\sigma)$ with $\omega_\gamma(A) < \sigma < \pi$, for all $x \in \mathcal{D}(A) \cap \mathcal{R}(A)$ we have*

$$\|x\| \leq c_0 \|t \mapsto \phi(tA)x\|_{\gamma(\mathbb{R}_+, \frac{dt}{t}; X)} \text{ and } \|t \mapsto \psi(tA)x\|_{\gamma(\mathbb{R}_+, \frac{dt}{t}; X)} \leq c_1 \|x\|,$$

then A has a bounded $H^\infty(\Sigma_\sigma)$ -calculus. In particular,

$$\omega_{H^\infty}(A) \leq \omega_\gamma(A).$$

Recall from Corollary 10.4.10 that $\omega_{H^\infty}(A) = \omega_\gamma(A)$ if we make the additional assumption that X has the triangular contraction property.

Proof. Fix an arbitrary $\omega_\gamma(A) < \nu < \sigma$. For $f \in H^1(\Sigma_\sigma) \cap H^\infty(\Sigma_\sigma)$ and $x \in \overline{\mathcal{R}(A)}$, from Proposition 10.4.17 we infer that

$$\begin{aligned} \|f(A)x\| &\leq c_0 \|t \mapsto f(A)\phi(tA)x\|_{\gamma(\mathbb{R}_+, \frac{dt}{t}; X)} \\ &\leq c_0 C_{\phi, \psi}(M_{\sigma, A}^\gamma)^2 \|f\|_{H^\infty(\Sigma_\sigma)} \|f\|_\infty \|t \mapsto \phi(tA)x\|_{\gamma(\mathbb{R}_+, \frac{dt}{t}; X)} \\ &\leq c_0 c_1 C_{\phi, \psi}(M_{\sigma, A}^\gamma)^2 \|f\|_\infty \|x\|, \end{aligned}$$

where $C_{\phi, \psi}$ is as in Proposition 10.4.17. This proves the result, with bound $M_{\nu, A}^\infty \leq c_0 c_1 C_{\phi, \psi}(M_{\sigma, A}^\gamma)^2$. \square

In Proposition 10.4.15 we have compared discrete and continuous square functions at different angles. As a final result in this section we give conditions under which discrete and continuous square functions are actually equivalent for a fixed angle.

Proposition 10.4.20. *Let A be an R -sectorial operator on a Banach space X with finite cotype. Let $\omega(A) < \sigma < \vartheta < \pi$. For all $\phi \in H^1(\Sigma_\vartheta)$ and $x \in \mathcal{D}(A) \cap \mathcal{R}(A)$ we have*

$$\|x\|_{\phi, A} \approx \|x\|_{\phi, A}$$

with a constant independent of x .

Proof. By Proposition 10.4.15(2) and Proposition 10.4.6, we have

$$\|x\|_{\phi, A} \lesssim_\delta C_X \sup_{|\beta| < \delta} \|x\|_{\phi_\beta, A} \lesssim_{\delta, \phi} C_X (M_{\nu, A}^R)^2 C_{\phi, \delta} \|x\|_{\phi, A}.$$

The converse estimate follows in the same way by instead applying Propositions 10.4.15(1) and 10.4.17. \square

Sectorial operators on Hilbert spaces revisited

In Hilbert spaces, square function estimates take a particularly simple form, since by Proposition 9.2.9 we have

$$L^2(\mathbb{R}_+, \frac{dt}{t}; H) \simeq \gamma(\mathbb{R}_+, \frac{dt}{t}; H)$$

isometrically. For this reason, they are sometimes referred to as *quadratic estimates*. Before coming to the main results, we also recall Proposition 10.1.9, which implies that sectorial operators in Hilbert spaces A are densely defined and satisfy $\overline{D(A)} \cap \overline{R(A)} = \overline{R(A)}$.

We have the following fundamental characterisation of sectorial Hilbert space operators with a bounded H^∞ -calculus of angle less than $\frac{1}{2}\pi$.

Theorem 10.4.21 (McIntosh). *For a sectorial operator A on a Hilbert space H the following assertions are equivalent:*

- (1) A has a bounded $H^\infty(\Sigma_\sigma)$ -calculus for some $\sigma \in (\omega(A), \pi)$;
- (2) A has a bounded $H^\infty(\Sigma_\sigma)$ -calculus for all $\sigma \in (\omega(A), \pi)$;
- (3) for some $\sigma \in (\omega(A), \pi)$ and some non-zero $\phi, \psi \in H^1(\Sigma_\sigma)$ there exist constants $c_0 \geq 0$ and $c_1 \geq 0$ such that

$$\|x\| \leq c_0 \|t \mapsto \phi(tA)x\|_{L^2(\mathbb{R}_+, \frac{dt}{t}; H)} \quad \text{and} \quad \|t \mapsto \psi(tA)x\|_{L^2(\mathbb{R}_+, \frac{dt}{t}; H)} \leq c_1 \|x\|$$

for all $x \in \overline{R(A)}$;

- (4) for all $\sigma \in (\omega(A), \pi)$ and all non-zero $\phi, \psi \in H^1(\Sigma_\sigma)$ there exist constants $c_0 \geq 0$ and $c_1 \geq 0$ such that

$$\|x\| \leq c_0 \|t \mapsto \phi(tA)x\|_{L^2(\mathbb{R}_+, \frac{dt}{t}; H)} \quad \text{and} \quad \|t \mapsto \psi(tA)x\|_{L^2(\mathbb{R}_+, \frac{dt}{t}; H)} \leq c_1 \|x\|$$

for all $x \in \overline{R(A)}$.

Moreover, we have equality of the bounds

$$\omega_{H^\infty}(A) = \omega_R(A) = \omega_\gamma(A) = \omega(A).$$

Proof. The equality $\omega_R(A) = \omega_\gamma(A) = \omega(A)$ is an immediate consequence of the fact that the notions of R -sectoriality, γ -sectoriality and sectoriality coincide in Hilbert spaces by Theorem 8.1.3.

(1) \Rightarrow (3) and (2) \Rightarrow (4): These implications follow from Theorem 10.4.16.

(3) \Rightarrow (2): This follows from Theorem 10.4.19 which also gives the inequality $\omega_{H^\infty}(A) \leq \omega(A)$; the converse inequality holds trivially.

(2) \Rightarrow (1) and (4) \Rightarrow (3): These implications are trivial. \square

If $-A$ is the generator of a C_0 -semigroup of contractions on Hilbert space, then A has a bounded H^∞ -calculus with $\omega_{H^\infty}(A) \leq \frac{1}{2}\pi$ by Theorem 10.2.24. The next result shows that in the case $\omega(A) < \frac{1}{2}\pi$, this actually gives a characterisation of the boundedness of the H^∞ -calculus.

Theorem 10.4.22 (Le Merdy). *A be a sectorial operator on a Hilbert space H with dense range and which satisfies $\omega(A) < \frac{1}{2}\pi$. Then the following assertions are equivalent:*

- (1) *A has a bounded H^∞ -calculus;*
- (2) *$-A$ generates C_0 -contraction semigroup with respect to some equivalent Hilbertian norm on H .*

Proof. (1) \Rightarrow (2): By Theorem 10.4.21 we have $\omega_{H^\infty}(A) = \omega(A) < \frac{1}{2}\pi$. Furthermore, Lemma 10.2.8, for the function $\varphi(z) = z \exp(-z)$ we have $\varphi(tA) = tAS(t)$, $t \geq 0$, where $(S(t))_{t \geq 0}$ denotes the bounded analytic C_0 -semigroup generated by $-A$ (see Theorem G.5.2). By Theorem 10.4.16,

$$\|x\| := \left\| t \mapsto \varphi(tA)x \right\|_{L^2(\mathbb{R}_+, \frac{dt}{t}; H)} = \left\| t \mapsto t^{1/2}AS(t)x \right\|_{L^2(\mathbb{R}_+; H)}$$

defines an equivalent Hilbertian norm on H , and the estimate

$$\|S(s)x\| = \left\| t \mapsto t^{1/2}AS(s+t)x \right\|_{L^2(\mathbb{R}_+; H)} \leq \left\| t \mapsto t^{1/2}AS(t)x \right\|_{L^2(\mathbb{R}_+; H)} = \|x\|$$

shows that $(S(t))_{t \geq 0}$ is contractive in this norm.

(2) \Rightarrow (1): This follows from Theorem 10.2.24. \square

Square functions and H^∞ -calculus in L^p -spaces

Theorem 10.4.23. *Let (S, \mathcal{A}, μ) be a σ -finite measure space and $p \in (1, \infty)$. Let A be a sectorial operator on $L^p(S)$. Consider the following assertions for $\sigma, \vartheta \in (\omega(A), \pi)$:*

- (1) *A has a bounded $H^\infty(\Sigma_\sigma)$ -calculus;*
- (2) *A is R -sectorial with $\omega_R(A) < \vartheta$ and for some (equivalently, all) non-zero $\phi \in H^1(\Sigma_\vartheta)$ there exist constants C_0 and C_1 such that*

$$C_0^{-1}\|x\|_p \leq \left\| \left(\int_0^\infty |\phi(tA)x|^2 dt \right)^{1/2} \right\|_p \leq C_1\|x\|_p$$

for all $x \in \overline{R(A)}$.

Then (1) \Rightarrow (2) holds if $\vartheta > \sigma$, and (2) \Rightarrow (1) holds if $\sigma \geq \vartheta$.

The constants in (2) can be taken as $C_0 = \|\phi\|_{L^2(\mathbb{R}_+, \frac{dt}{t})}^{-2} C$ and $C_1 = C_p C$, where $C := C_{\vartheta, \sigma} M_{\sigma, A}^\infty M_{\sigma, A} \|\phi\|_{H^1(\Sigma_\vartheta)}$. The theorem remains true if $L^p(S)$ is replaced by any reflexive Banach function space with finite cotype.

Proof. Since $L^p(S)$ is reflexive, $D(A)$ is dense by Proposition 10.1.9. Since $L^p(S)$ has the triangular contraction principle and finite cotype, the implication (1) \Rightarrow (2) for $\vartheta > \sigma$ is immediate from Theorems 10.3.4 (R -sectoriality) and 9.3.8 and 10.4.16 (square function estimates). The implication (2) \Rightarrow (1) for $\sigma \geq \vartheta$ follows from Theorem 10.4.19, recalling that R -sectoriality implies γ -sectoriality. \square

Similarly, Theorem 10.3.4 and Corollary 10.4.10 imply the following result.

Theorem 10.4.24. *Let (S, \mathcal{A}, μ) be a σ -finite measure space and $p \in (1, \infty)$. Let A be a sectorial operator with dense range and with a bounded $H^\infty(\Sigma_\sigma)$ -calculus on $L^p(S)$. Then A is R -sectorial, $\omega_R(A) = \omega_{H^\infty}(A)$ and the set*

$$\{f(A) : f \in H^\infty(\Sigma_\sigma), \|f\|_{H^\infty(\Sigma_\sigma)} \leq 1\}$$

is R -bounded, with R -bound at most $C_{\eta,\sigma}(M_{\eta,A}^\infty)^2 C_p$, for any $\omega(A) < \eta < \sigma$.

10.4.c The quadratic H^∞ -calculus

In the preceding subsection we have characterised, under suitable assumptions on A and X , the boundedness of the H^∞ -calculus of a sectorial operator A on X in terms of continuous square function estimates of the form

$$\|t \mapsto \phi(tA)x\|_{\gamma(\mathbb{R}_+, \frac{dt}{t}; X)} \approx \|x\|$$

under the assumption $\phi \in H^1(\Sigma)$ for a suitable sector Σ . By restriction, such functions belong to $H^\infty(\Sigma')$, and hence to $H^p(\Sigma')$ for all $1 < p < \infty$, for any sector Σ' properly contained in Σ (see Proposition H.2.4). In particular they belong to $H^2(\Sigma')$, and the quadratic nature of square functions prompts the natural question whether the above equivalence of norms extends to arbitrary functions $\phi \in H^2(\Sigma)$. The affirmative answer to this question will be deduced from another result, which is of considerable interest in itself: the mapping $\phi \mapsto \phi(A)$, viewed as a bounded mapping

$$H^\infty(\Sigma) \rightarrow \mathcal{L}(X),$$

extends to a bounded linear mapping

$$H^\infty(\Sigma; H^*) \rightarrow \mathcal{L}(X, \gamma(H, X))$$

for any Hilbert space H , provided X has finite cotype. Taking $H = L^2(\mathbb{R}_+, \frac{dt}{t})$ will answer the question above (see Theorem 10.4.27).

Theorem 10.4.25 (Haak and Haase, Le Merdy). *Let A be a sectorial operator on a Banach space X with finite cotype q , with dense range and dense domain, and assume that A has a bounded $H^\infty(\Sigma_\sigma)$ -functional calculus. Let H be a Hilbert space, let $\sigma < \vartheta < \pi$, and define, for $F \in H^\infty(\Sigma_\vartheta; H^*)$, the operator $F(A) : X \rightarrow \mathcal{L}(H, X)$ by*

$$[F(A)x]h := \langle h, F \rangle(A)x, \quad x \in X, \quad h \in H.$$

Then $F(A)$ maps X into $\gamma(H, X)$ boundedly and

$$\|F(A)\|_{\mathcal{L}(X, \gamma(H, X))} \leq C_{q,X} C_{\sigma,\vartheta} (M_{\sigma,A}^\infty)^2 \|F\|_{H^\infty(\Sigma_\sigma; H^*)},$$

where $C_{q,X} = 2c_{q,X} q^{1/q} \|\gamma\|_{2q}$, where γ is a standard Gaussian variable.

We start with a preliminary result on sequences of holomorphic functions which is an analogue of Lemma 10.3.8(1).

Lemma 10.4.26. *Let A be a sectorial operator with a bounded $H^\infty(\Sigma_\sigma)$ -functional calculus on a Banach space X . Let $f = (f_n)_{n \geq 1} \in H^\infty(\Sigma_\sigma; \ell^1)$. Then for all finite sets $I \subseteq \mathbb{N}_{>0}$ and scalars $|\alpha_n| \leq 1$ ($n \in I$),*

$$\left\| \sum_{n \in I} \alpha_n f_n(A)x \right\| \leq M_{\sigma, A}^\infty \|f\|_{H^\infty(\Sigma_\sigma; \ell^1)} \|x\|, \quad x \in \overline{\mathbb{D}(A) \cap \mathbb{R}(A)}.$$

Proof. Let $I \subseteq \mathbb{N}$ be finite and let $\phi_I = \sum_{n \in I} \alpha_n f_n$. Then $\phi_I \in H^\infty(\Sigma_\sigma)$ and $\|\phi_I\|_{H^\infty(\Sigma_\sigma)} \leq \|f\|_{H^\infty(\Sigma_\sigma; \ell^1)}$. Therefore, for all $x \in \overline{\mathbb{D}(A) \cap \mathbb{R}(A)}$,

$$\left\| \sum_{n \in I} \alpha_n f_n(A)x \right\| = \|\phi_I(A)x\| \leq M_{\sigma, A}^\infty \|f\|_{H^\infty(\Sigma_\sigma; \ell^1)} \|x\|$$

by the boundedness of the H^∞ -calculus. \square

Lemma 10.4.26 is the only place where the boundedness of the functional calculus is used.

Proof of Theorem 10.4.25. We may assume that $\|F\|_{H^\infty(\Sigma_\vartheta; H^*)} = 1$. By Theorem H.3.1, F admits a representation of the form

$$F(z) = \sum_{n \geq 1} f_n(z) g_n(z) h_n^*, \quad z \in \Sigma_\sigma,$$

where $\|(f_n)_{n \geq 1}\|_{H^\infty(\Sigma_\sigma; \ell^1)} \leq 1$, $\|(g_n)_{n \geq 1}\|_{H^\infty(\Sigma_\sigma; \ell^1)} \leq 1$, and $\|h_n^*\| \leq C_{\sigma, \vartheta}$. Moreover, by the properties of the functional calculus (see Theorem 10.2.13), for all $h \in H$ and $x \in X$ we have

$$[(h, F)](A)x = \sum_{n \geq 1} \langle h, h_n^* \rangle f_n(A) g_n(A)x.$$

Let $(h_j)_{j \in J}$ be a finite orthonormal system in H and let $(\gamma_j)_{j \geq 1}$ be a Gaussian sequence on a probability space (Ω, \mathbb{P}) . For $n \geq 1$ put

$$\widehat{\gamma}_n := \sum_{j \in J} \gamma_j \langle h_j, h_n^* \rangle.$$

Then each $\widehat{\gamma}_n$ is a Gaussian random variable and for all $r \in [1, \infty)$ we have

$$\|\widehat{\gamma}_n\|_r = \|\gamma\|_r \left(\sum_{j \in J} |\langle h_j, h_n^* \rangle|^2 \right)^{1/2} \leq \|\gamma\|_r \|h_n^*\| \leq C_{\sigma, \vartheta} \|\gamma\|_r. \quad (10.36)$$

Using the identity $[F(A)x]h_j = [\langle h_j, F \rangle](A)x$ and the representation formula for F , we obtain

$$\begin{aligned} \left\| \sum_{j \in J} \gamma_j [F(A)x] h_j \right\|_{L^2(\Omega; X)} &= \left\| \sum_{n \geq 1} \widehat{\gamma}_n f_n(A) g_n(A)x \right\|_{L^2(\Omega; X)} \\ &\leq \liminf_{N \rightarrow \infty} \left\| \sum_{n=1}^N \widehat{\gamma}_n f_n(A) g_n(A)x \right\|_{L^2(\Omega; X)}. \end{aligned}$$

Let $(\varepsilon'_n)_{n \geq 1}$ be a Rademacher sequence on a distinct probability space (Ω', \mathbb{P}') . By randomisation and Lemma 10.4.26 applied pointwise in Ω , we have

$$\begin{aligned} \left\| \sum_{n=1}^N \widehat{\gamma}_n f_n(A) g_n(A)x \right\|_{L^2(\Omega; X)} &\leq \left\| \sum_{m=1}^N \varepsilon'_m f_m(A) \sum_{n=1}^N \widehat{\gamma}_n \varepsilon'_n g_n(A)x \right\|_{L^2(\Omega \times \Omega'; X)} \\ &\leq M_{\sigma, A}^\infty \left\| \sum_{n=1}^N \widehat{\gamma}_n \varepsilon'_n g_n(A)x \right\|_{L^2(\Omega \times \Omega'; X)}. \end{aligned}$$

Since X has cotype $q < \infty$, from Theorem 7.2.6(2) and (10.36) we deduce that

$$\left\| \sum_{n=1}^N \widehat{\gamma}_n \varepsilon'_n g_n(A)x \right\|_{L^2(\Omega \times \Omega'; X)} \leq C_{q, X} C_{\sigma, \vartheta} \left\| \sum_{n=1}^N \varepsilon'_n g_n(A)x \right\|_{L^q(\Omega'; X)},$$

where $C_{q, X} = 2c_{q, X} q^{1/q} \|\gamma\|_{2q}$. By Lemma 10.4.26 applied pointwise in Ω' , we have $\left\| \sum_{n=1}^N \varepsilon'_n g_n(A)x \right\| \leq M_{\sigma, A}^\infty \|x\|$. Combining all estimates we obtain the estimate

$$\|F(A)x\|_{\gamma_\infty(H, X)} \leq \sup_h \left\| \sum_{j \in J} \gamma_j [F(A)x] h_j \right\|_{L^2(\Omega; X)} \leq C_{q, X} C_{\sigma, \vartheta} (M_{\sigma, A}^\infty)^2 \|x\|,$$

where the supremum extends over all finite orthonormal systems $h = (h_j)_{j \in J}$ in H . This proves the required result, since by Theorem 9.1.20 we have $\gamma_\infty(H, X) = \gamma(H, X)$, for the finite cotype assumption implies that X does not contain an isomorphic copy of c_0 . \square

Next we consider the special case $H = L^2(\mathbb{R}_+, \frac{dt}{t})$ and obtain the announced extension of Theorem 10.4.161 to functions $\phi \in H^2(\Sigma_\vartheta)$.

Theorem 10.4.27 (γ -Square functions). *Let A be a sectorial operator with a bounded $H^\infty(\Sigma_\sigma)$ -calculus on a Banach space X with finite cotype q . Let $0 < \sigma < \vartheta < \pi$. For all $\phi \in H^2(\Sigma_\vartheta)$ and all $x \in \overline{\mathbb{D}(A)} \cap \mathbb{R}(A)$ the function $t \mapsto \phi(tA)x$ belongs to $\gamma(\mathbb{R}_+, \frac{dt}{t}, X)$ and*

$$\|t \mapsto \phi(tA)x\|_{\gamma(\mathbb{R}_+, \frac{dt}{t}, X)} \leq C_{q, X} C_{\sigma, \vartheta} (M_{\sigma, A}^\infty)^2 \|\phi\|_{H^2(\Sigma_\vartheta)} \|x\|$$

where the constants $C_{q, X}$ and $C_{\sigma, \vartheta}$ are as in Theorem 10.4.25.

Proof. Let $\sigma < \vartheta' < \vartheta$. The assumption on ϕ implies that $F(z) := [t \mapsto \phi(tz)]$ defines an element of $H^\infty(\Sigma_{\vartheta'}; L^2(\mathbb{R}_+, \frac{dt}{t}))$ of norm $\|F\|_{H^\infty(\Sigma_{\vartheta'}; L^2(\mathbb{R}_+, \frac{dt}{t}))} = \|\phi\|_{H^2(\Sigma_\vartheta)}$. Using Lemma 10.2.16, for $h \in L^2(\mathbb{R}_+, \frac{dt}{t})$ we have

$$[F(A)x]h = \int_0^\infty h(t)\phi(tA)x \frac{dt}{t}.$$

This shows that in $\mathcal{L}(L^2(\mathbb{R}_+, \frac{dt}{t}), X)$ we have $F(A)x = [t \mapsto \phi(tA)x]$. Now by Theorem 10.4.25, for all $x \in \overline{D(A) \cap R(A)}$ we obtain that $t \mapsto \phi(tA)x$ belongs to $\gamma(\mathbb{R}_+, \frac{dt}{t}, X)$ and gives the estimate

$$\|t \mapsto \phi(tA)x\|_{\gamma(\mathbb{R}_+, \frac{dt}{t}, X)} \leq C_{q,X} C_{\sigma,\vartheta} (M_{\sigma,A}^\infty)^2 \|\phi\|_{H^2(\Sigma_\vartheta)} \|x\|.$$

□

10.4.d Le Merdy’s theorem on the angle of the H^∞ -calculus

In the previous section it has been shown that if A is densely defined and has a bounded H^∞ -calculus on a Banach space with the triangular contraction property, then A is R -sectorial and $\omega_R(A) = \omega_{H^\infty}(A)$. In many applications one knows that $\omega(A) < \frac{1}{2}\pi$, for instance when A is given by a sectorial form of when $-A$ generates a bounded analytic C_0 -semigroup (see Appendix G for the precise statements). In such situations it is natural to ask whether one also has $\omega_R(A) = \omega_{H^\infty}(A) < \frac{1}{2}\pi$. Since there are many interesting holomorphic functions which are bounded on every proper subsector of \mathbb{C}_+ , such as $z^\alpha \exp(-z)$ with $\alpha > 0$, knowing that the angles are strictly smaller than $\frac{1}{2}\pi$ is quite a useful piece of information. In this section we present a theorem due to Le Merdy describing a situation where this happens. It prominently features the functions

$$\varphi_\alpha(z) := z^\alpha \exp(-z), \quad z \in \mathbb{C}_+,$$

where $\alpha > 0$. If $\omega(A) < \frac{1}{2}\pi$, then the operators $\varphi_\alpha(tA)$ are well defined for all $t > 0$ by the Dunford calculus, and Lemma 10.4.14 shows that if all $x \in D(A) \cap R(A)$, then the function $t \mapsto \varphi_\alpha(tA)x$ belongs to $\gamma(\mathbb{R}_+, \frac{dt}{t}; X)$. The theorem is concerned with what happens if a two-sided square function estimate holds:

Theorem 10.4.28 (Le Merdy). *Let A be a densely defined sectorial operator with dense range, and which satisfies $\omega(A) < \frac{1}{2}\pi$, on a Banach space X with Pisier’s contraction property. Suppose there is a constant $C > 0$ such that the following two-sided estimate holds for all $x \in D(A) \cap R(A)$:*

$$C^{-1} \|x\| \leq \|t \mapsto \varphi_{1/2}(tA)x\|_{\gamma(\mathbb{R}_+, \frac{dt}{t}; X)} \leq C \|x\|. \tag{10.37}$$

Then A is R -sectorial and has a bounded H^∞ -calculus, and we have

$$\omega_R(A) = \omega_{H^\infty}(A) < \frac{1}{2}\pi.$$

All the steps in the proof rely on explicit quantitative estimates involving the relevant constants, namely, the angle of sectoriality $\omega(A)$, the sectoriality constants $M_{\sigma,A}$ for $\omega(A) < \sigma < \frac{1}{2}\pi$, the constants associated with Pisier’s contraction property, and the constants in (10.37). As a consequence it is possible to give an explicit estimate for the difference $\frac{1}{2}\pi - \omega_R(A)$. Since the resulting expression is complicated and not likely to provide any new insights, we leave this to the interested reader.

Pisier’s contraction property will enter through Corollary 9.4.11, which implies that if X has this property, then we have a natural isomorphism of Banach spaces

$$\gamma(T \times S; X) \simeq \gamma(T; \gamma(S; X)) \tag{10.38}$$

whenever (S, Σ, μ) and (T, \mathcal{B}, ν) are σ -finite measure spaces.

We begin with a simple extension result.

Lemma 10.4.29. *Let X, Y be Banach spaces, (S, \mathcal{A}, μ) and (T, \mathcal{B}, ν) measure spaces, and let $\Psi: T \rightarrow \mathcal{L}(X, Y)$ a function such that for every $x \in X$ the function $t \mapsto \Psi(t)x$ belongs to $\gamma(T, Y)$ and*

$$C^{-1}\|x\| \leq \|t \mapsto \Psi(t)x\|_{\gamma(T; X)} \leq C\|x\|.$$

If $f \in \gamma(S; X)$, then $t \mapsto [s \mapsto \Psi(t)f(s)]$ belongs to $\gamma(T; \gamma(S; Y))$ and

$$C^{-1}\|f\|_{\gamma(S; X)} \leq \|\Psi f\|_{\gamma(T; \gamma(S; Y))} \leq C\|f\|_{\gamma(S; X)}.$$

Proof. First we check that the mapping $t \mapsto \Psi(t)f(\cdot)$ is strongly ν -measurable as a function from T to $\gamma(S, Y)$. By Example 9.1.16 it suffices to check that $t \mapsto \Psi(t)\mathbb{1}_f h$ is measurable for all $h \in L^2(S)$, and this is clear from the assumptions.

The next step is to show that the mapping $t \mapsto [s \mapsto \Psi(t)f(s)]$ defines an element of $\gamma(T, \gamma(S, Y))$ and satisfies the required norm estimate for any $f \in \gamma(S; X)$. Recall from Proposition 9.4.9 that this space isometrically coincides with $\gamma(S, \gamma(T, Y))$.

First consider a μ -simple function $f = \sum_{n=1}^N \frac{1}{\sqrt{|A_n|}} \mathbf{1}_{A_n} \otimes x_n$ with disjoint measurable sets $A_n \subseteq S$ of finite positive μ -measure. Then $t \mapsto \Psi(t)f(\cdot) = \sum_{n=1}^N \frac{1}{\sqrt{|A_n|}} \mathbf{1}_{A_n}(\cdot) \Psi(t)x_n$ is a μ -simple function with values in $\gamma(T; Y)$ and therefore, by Proposition 9.1.3, it belongs to $\gamma(S; \gamma(T; Y))$ and its norm is given by

$$\begin{aligned} \|t \mapsto [s \mapsto \Psi(t)f(s)]\|_{\gamma(T, \gamma(S, Y))}^2 &= \|s \mapsto [t \mapsto \Psi(t)f(s)]\|_{\gamma(S, \gamma(T, Y))}^2 \\ &= \mathbb{E} \left\| \sum_{n=1}^N \gamma_n [t \mapsto \Psi(t)x_n] \right\|_{\gamma(T; Y)}^2 \\ &\leq C^2 \mathbb{E} \left\| \sum_{n=1}^N \gamma_n x_n \right\|^2 = C^2 \|f\|_{\gamma(S; X)}^2, \end{aligned}$$

where in the penultimate step we used the assumption on Ψ . By a density argument (see Proposition 9.2.5) the result extends to general $f \in \gamma(S; X)$.

The lower estimate also follows from

$$C^2 \mathbb{E} \left\| \sum_{n=1}^N \gamma_n [t \mapsto \Psi(t)x_n] \right\|_{\gamma(T; Y)}^2 \geq \mathbb{E} \left\| \sum_{n=1}^N \gamma_n x_n \right\|_X^2 = \|f\|_{\gamma(S; X)}^2,$$

using the assumed lower bound for Ψ . \square

The next lemma takes advantage of the specific properties of the functions $\varphi_\alpha(z) = z^\alpha \exp(-z)$.

Lemma 10.4.30. *Let X be a Banach space with Pisier's contraction property. Let $\alpha, \beta > 0$ and assume that there constants $C_{0,A}$ and $C_{1,A}$ such that*

$$\begin{aligned} C_{0,A}^{-1} \|x\| &\leq \|t \mapsto \varphi_\alpha(tA)x\|_{\gamma(\mathbb{R}_+, \frac{dt}{t}; X)} \leq C_{0,A} \|x\|, \\ C_{1,A}^{-1} \|x\| &\leq \|t \mapsto \varphi_\beta(tA)x\|_{\gamma(\mathbb{R}_+, \frac{dt}{t}; X)} \leq C_{1,A} \|x\|, \end{aligned}$$

for all $x \in \mathcal{D}(A) \cap \mathcal{R}(A)$. Then for all $x \in \mathcal{D}(A) \cap \mathcal{R}(A)$,

$$C^{-1} \|x\| \leq \|t \mapsto \varphi_{\alpha+\beta}(tA)x\|_{\gamma(\mathbb{R}_+, \frac{dt}{t}; X)} \leq C \|x\|,$$

where $C = C_X C_{\alpha,\beta} C_{0,A} C_{1,A}$ for some constants $C_X, C_{\alpha,\beta} > 0$.

Proof. By the multiplicativity of the Dunford calculus, for all $s, t > 0$ we have

$$\varphi_\alpha(tA)\varphi_\beta(sA) = \lambda(s, t)\varphi_{\alpha+\beta}((s+t)A),$$

where $\lambda(s, t) = \frac{s^\alpha t^\beta}{(t+s)^{\alpha+\beta}}$. The following simple identity for functions $h \in L^2(\mathbb{R}_+, \frac{ds}{s})$ is the key to the proof:

$$\begin{aligned} \int_0^\infty \int_0^\infty |\lambda(s, t)h(t+s)|^2 \frac{ds}{s} \frac{dt}{t} &= \int_0^\infty \int_t^\infty \frac{(s-t)^{2\alpha-1} t^{2\beta}}{s^{2\alpha+2\beta}} |h(s)|^2 ds \frac{dt}{t} \\ &= \int_0^\infty \int_0^s \frac{(s-t)^{2\alpha-1} t^{2\beta}}{s^{2\alpha+2\beta}} |h(s)|^2 \frac{dt}{t} ds \\ &= \int_0^\infty \int_0^1 (1-t)^{2\alpha-1} t^{2\beta-1} |h(s)|^2 dt \frac{ds}{s} \\ &= C_{\alpha,\beta}^2 \int_0^\infty |h(s)|^2 \frac{ds}{s}. \end{aligned}$$

Stated differently, $h \mapsto C_{\alpha,\beta}^{-1}[(s, t) \mapsto \lambda(s, t)h(s+t)]$ is an isometric mapping from $L^2(\mathbb{R}_+, \frac{ds}{s})$ into $L^2(\mathbb{R}_+ \times \mathbb{R}_+, \frac{ds}{s} \times \frac{dt}{t})$. By Theorem 9.6.1 it has an isometric γ -extension from $\gamma(\mathbb{R}_+, \frac{ds}{s}; X)$ into $\gamma(\mathbb{R}_+^2, \frac{ds}{s} \times \frac{dt}{t}; X)$. For all $x \in \mathcal{D}(A) \cap \mathcal{R}(A)$ the function $s \mapsto \varphi_{\alpha+\beta}(sA)x$ belongs to $\gamma(\mathbb{R}_+, \frac{ds}{s}; X)$ by Proposition 10.4.14 and therefore

$$\begin{aligned}
& \left\| s \mapsto \varphi_{\alpha+\beta}(sA)x \right\|_{\gamma(\mathbb{R}_+, \frac{ds}{s}; X)} \\
&= C_{\alpha,\beta} \left\| (s,t) \mapsto \lambda(s,t) \varphi_{\alpha+\beta}((s+t)A)x \right\|_{\gamma(\mathbb{R}_+^2, \frac{ds}{s} \times \frac{dt}{t}; X)} \\
&= C_{\alpha,\beta} \left\| (s,t) \mapsto \varphi_\alpha(tA) \varphi_\beta(sA)x \right\|_{\gamma(\mathbb{R}_+^2, \frac{ds}{s} \times \frac{dt}{t}; X)}.
\end{aligned}$$

It remains to estimate the last expression. Using Pisier's contraction property in the form (10.38), it follows that

$$\begin{aligned}
& \left\| (s,t) \mapsto \varphi_\alpha(tA) \varphi_\beta(sA)x \right\|_{\gamma(\mathbb{R}_+^2, \frac{ds}{s} \times \frac{dt}{t}; X)} \\
& \quad \lesssim_X \left\| t \mapsto [s \mapsto \varphi_\alpha(tA) \varphi_\beta(sA)x] \right\|_{\gamma(\mathbb{R}_+; \frac{dt}{t}; \gamma(\mathbb{R}_+, \frac{ds}{s}; X))} \\
& \quad \leq C_{0,A} \left\| s \mapsto \varphi_\beta(sA)x \right\|_{\gamma(\mathbb{R}_+, \frac{ds}{s}; X)} \leq C_{0,A} C_{1,A} \|x\|,
\end{aligned}$$

where the two inequalities follow from Lemma 10.4.29 and the assumption. The upper estimate of the lemma follows by combining the above estimates.

The lower estimate is proved in the same way, this time using the lower estimate of Lemma 10.4.29. \square

The next lemma, which is again based on Pisier's contraction property, will allow us to manipulate γ -norms.

Lemma 10.4.31. *Let X be a Banach space with Pisier's contraction property. Let ν be a σ -finite measure on \mathbb{R}_+ and assume that $t \mapsto [s \mapsto f(s,t)]$ belongs to $\gamma(\mathbb{R}_+, \nu; \gamma(\mathbb{R}_+; X))$. Then for all $g \in L^\infty(\mathbb{R}_+^2)$ the function $t \mapsto [s \mapsto g(s,t)f(s+t,t)]$ defines an element of $\gamma(\mathbb{R}_+, \nu; \gamma(\mathbb{R}_+; X))$ and*

$$\begin{aligned}
& \left\| s \mapsto [t \mapsto g(s,t)f(s+t,t)] \right\|_{\gamma(\mathbb{R}_+; \gamma(\mathbb{R}_+, \nu; X))} \\
& \quad \leq C_X \|g\|_\infty \left\| s \mapsto [t \mapsto f(s,t)] \right\|_{\gamma(\mathbb{R}_+; \gamma(\mathbb{R}_+, \nu; X))}.
\end{aligned}$$

Proof. Let λ denote the Lebesgue measure on \mathbb{R}_+ . We begin by observing that for all $h \in L^2(\mathbb{R}_+ \times \mathbb{R}_+, \lambda \times \nu)$ the following estimate holds:

$$\int_0^\infty \int_0^\infty |g(s,t)h(s+t,t)|^2 ds d\nu(t) \leq \|g\|_\infty^2 \int_0^\infty \int_0^\infty |h(s,t)|^2 ds d\nu(t).$$

By Theorem 9.6.1 this estimate has the γ -extension

$$\begin{aligned}
& \left\| (s,t) \mapsto g(s,t)f(s+t,t) \right\|_{\gamma(\mathbb{R}_+^2, \lambda \times \nu; X)} \\
& \quad \leq \|g\|_\infty \left\| (s,t) \mapsto f(s,t) \right\|_{\gamma(\mathbb{R}_+^2, \lambda \times \nu; X)}.
\end{aligned}$$

Now the result follows by applying (10.38). \square

Proof of Theorem 10.4.28. The key point is to prove that A is R -sectorial with angle $\omega_R(A) < \frac{1}{2}\pi$. Once we know this, the remaining assertions follow from the earlier results in this chapter. Indeed, Theorem 10.4.9 then implies

that A has a bounded H^∞ -calculus of angle $\omega_{H^\infty}(A) \leq \omega_R(A)$, and then Corollary 10.4.10 gives that $\omega_{H^\infty}(A) = \omega_R(A)$.

To prove that A is R -sectorial, according to Proposition 10.3.3 it suffices to show that the sets

$$\{S(s) : s \geq 0\} \text{ and } \{sAS(s) : s \geq 0\} \quad (10.39)$$

are R -bounded. Since X has Pisier's contraction property, it has finite cotype by Corollary 7.5.13, and therefore, γ -boundedness and R boundedness are equivalent by Theorem 8.1.3). Thus it suffices to check the γ -boundedness of the operator families in (10.39).

Repeated use of Lemma 10.4.30 gives that for all integers $k \geq 1$ and $x \in D(A) \cap R(A)$,

$$C^{-2k} \|x\| \leq \|s \mapsto \varphi_k(sA)x\|_{\gamma(\mathbb{R}_+, \frac{ds}{s}; X)} \leq C^{2k} \|x\|, \quad (10.40)$$

where C is as in Lemma 10.4.30. By Lemma 10.2.8 and the multiplicativity of the Dunford calculus applied to the function $(ze^{-z/k})^k = z^k e^{-z}$, we obtain $\varphi_k(sA) = s^k A^k S(s)$, where $(S(s))_{s \geq 0}$ denotes the analytic semigroup generated by $-A$. Therefore, (10.40) becomes

$$C^{-2k} \|x\| \leq \|s \mapsto s^{k-\frac{1}{2}} A^k S(s)x\|_{\gamma(\mathbb{R}_+; X)} \leq C^{2k} \|x\|. \quad (10.41)$$

Turning to the proof of the γ -boundedness of the set $\{S(s) : s \geq 0\}$, fix a finite sequence $(t_n)_{n=1}^N$ of non-negative real numbers and a sequence $(x_n)_{n=1}^N$ in $D(A) \cap R(A)$. Then applying the lower and upper estimate of (10.41) with $k = 1$ (in the first and last step) and Lemma 10.4.31 with $g(s, n) = \frac{s^{1/2}}{(s+t_n)^{1/2}}$ and $f(s, n) = s^{1/2} AS(s)x_n$, we obtain

$$\begin{aligned} & C^{-2} \left\| \sum_{n=1}^N \gamma_n S(t_n) x_n \right\|_{L^2(\Omega; X)} \\ & \leq \left\| s \mapsto \sum_{n=1}^N \gamma_n s^{1/2} AS(s+t_n) x_n \right\|_{L^2(\Omega; \gamma(\mathbb{R}_+; X))} \\ & = \left\| s \mapsto \left[n \mapsto \frac{s^{1/2}}{(s+t_n)^{1/2}} (s+t_n)^{1/2} AS(s+t_n) x_n \right] \right\|_{\gamma(\mathbb{R}_+; \gamma_N(X))} \\ & \leq C_X \left\| s \mapsto \left[n \mapsto s^{1/2} AS(s) x_n \right] \right\|_{\gamma(\mathbb{R}_+; \gamma_N(X))} \\ & = C_X \left\| s \mapsto s^{1/2} AS(s) \sum_{n=1}^N \gamma_n x_n \right\|_{L^2(\Omega; \gamma(\mathbb{R}_+; X))} \\ & \leq C^2 C_X \left\| \sum_{n=1}^N \gamma_n x_n \right\|_{L^2(\Omega; X)}. \end{aligned}$$

This shows that the set $\{S(s) : s \geq 0\}$ is γ -bounded, with constant $C^4 C_X$.

The proof of the γ -boundedness of $\{sAS(s) : s \geq 0\}$ proceeds in the same way, this time applying the lower and upper estimate of (10.41) with $k = 1$ and $k = 2$, respectively, and Lemma 10.4.31 with $g(s, n) = \frac{st_n}{(s+t_n)^2}$, where $f(s, n) = s^2 A^2 S(s)x_n$. With these choices,

$$\begin{aligned} & C^{-2} \left\| \sum_{n=1}^N \gamma_n t_n A S(s_n) x_n \right\|_{L^2(\Omega; X)} \\ & \leq \left\| s \mapsto \sum_{n=1}^N \gamma_n t_n s^{1/2} A^2 S(s+t_n) x_n \right\|_{L^2(\Omega; \gamma(\mathbb{R}_+; X))} \\ & = \left\| s \mapsto \left[n \mapsto \frac{t_n s^{1/2}}{(s+t_n)^{3/2}} (s+t_n)^{3/2} A^2 S(s+t_n) x_n \right] \right\|_{\gamma(\mathbb{R}_+; \gamma_N(X))} \\ & \leq \frac{1}{3} C_X \left\| s \mapsto \left[n \mapsto s^{3/2} A^2 S(s) x_n \right] \right\|_{\gamma(\mathbb{R}_+; \gamma_N(X))} \\ & = \frac{1}{3} C_X \left\| s \mapsto s^{3/2} A^2 S(s) \sum_{n=1}^N \gamma_n x_n \right\|_{L^2(\Omega; \gamma(\mathbb{R}_+; X))} \\ & \leq \frac{1}{3} C^4 C_X \left\| \sum_{n=1}^N \gamma_n x_n \right\|_{L^2(\Omega; X)}. \end{aligned}$$

This shows that the set $\{sAS(s) : s \geq 0\}$ is γ -bounded, with constant $\frac{1}{3} C^6 C_X$. \square

Remark 10.4.32.

(1) Instead of (10.40) one could use the following estimates in the above proof:

$$\begin{aligned} C^{-1} \|x\| & \leq \left\| t \mapsto \varphi_{1/2}(tA)x \right\|_{\gamma(\mathbb{R}_+, \frac{dt}{t}; X)} \leq C \|x\| \\ & \left\| t \mapsto \varphi_{3/2}(tA)x \right\|_{\gamma(\mathbb{R}_+, \frac{dt}{t}; X)} \leq C^3 \|x\|. \end{aligned}$$

This gives the result with a better constant, but we haven't introduced fractional powers yet.

(2) Theorem 10.4.28 also holds if we assume the square function estimate holds for $\varphi_{1/n}(tA)$, where $n \geq 1$ is an integer instead of $\varphi_{1/2}(tA)$. To see this it suffices to observe that a repeated use of Lemma 10.4.30 still implies (10.40).

10.5 Necessity of UMD and Pisier's contraction property

This section is devoted to proving the necessity of the UMD property (resp. Pisier's contraction property) for the boundedness (resp. R -boundedness) of the imaginary powers of the negative Laplace operator $-\Delta$ on $L^p(\mathbb{R}^d; X)$. This

shows in particular the necessity of these assumption in Theorems 10.2.25 and 10.3.4(3). We begin with:

Theorem 10.5.1 (Guerre-Delabrière). *If the operators $(-\Delta)^{is}$ are uniformly bounded on $L_0^p(\mathbb{T}; X)$ for $s \in (0, 1]$, then X is a UMD space, and*

$$\beta_{p,X} \leq \liminf_{s \downarrow 0} \|(-\Delta)^{is}\|_{\mathcal{L}(L^p(\mathbb{T}; X))}.$$

Recall that $L_0^p(\mathbb{T}; X) := \{f \in L^p(\mathbb{T}; X) : \int f = 0\}$. Before going to the proof, we record:

Corollary 10.5.2 (Guerre-Delabrière). *If the operators $(-\Delta)^{is}$ are uniformly bounded on $L^p(\mathbb{R}^d; X)$ for $s \in (0, 1]$, then X is a UMD space, and*

$$\beta_{p,X} \leq \liminf_{s \downarrow 0} \|(-\Delta)^{is}\|_{\mathcal{L}(L^p(\mathbb{R}^d; X))}.$$

In particular, this shows that the UMD assumption is necessary in Theorem 10.2.25, not only for the Laplacian to have functional calculus of angle 0 on $L^p(\mathbb{R}^d; X)$, but in fact for it to have a functional calculus of any angle at all. Indeed, the functions $f_s(z) = z^{is} = \exp(is \log z)$ are bounded and holomorphic on the largest possible sector $\Sigma_\pi = \mathbb{C} \setminus (-\infty, 0]$.

Proof. We observe that $(-\Delta)^{is}$ on $L^p(\mathbb{R}^d; X)$ is the Fourier multiplier T_m with multiplier $m(\xi) = (2\pi|\xi|)^{i2s}$; similarly, $(-\Delta)^{is}$ on $L_0^p(\mathbb{T}^d; X)$ is the periodic Fourier multiplier $\tilde{T}_{\tilde{m}}$ with multiplier $\tilde{m}(k) = (2\pi|k|)^{i2s}$, $k \in \mathbb{Z}^d \setminus \{0\}$.

Step 1: We apply a slight variant of the transference of Fourier multipliers given in Proposition 5.7.1. It says that if every $k \in \mathbb{Z}^d$ is a Lebesgue point of $m \in L^\infty(\mathbb{R}^d)$, then $(m(k))_{k \in \mathbb{Z}^d}$ is a Fourier multiplier on $L^p(\mathbb{T}^d; X)$ of at most the norm of the Fourier multiplier m on $L^p(\mathbb{R}^d; X)$. A slight obstacle is that 0 is not a Lebesgue point of our $m(\xi)$, no matter how we define $m(0)$. But, if we only consider the action of these operators on $L_0^p(\mathbb{T}^d; X)$, the 0th frequency never shows up, and one can check that the proof of Proposition 5.7.1 also applies, with trivial modifications, to the case that each $k \in \mathbb{Z}^d \setminus \{0\}$ is a Lebesgue point, giving in this case

$$\begin{aligned} \|\tilde{T}_{(m(k))_{k \in \mathbb{Z}^d \setminus \{0\}}}\|_{\mathcal{L}(L_0^p(\mathbb{T}^d; X))} &\leq \|T_m\|_{\mathcal{L}(L^p(\mathbb{R}^d; X))}, & \text{i.e.} \\ \|(-\Delta)^{is}\|_{\mathcal{L}(L_0^p(\mathbb{T}^d; X))} &\leq \|(-\Delta)^{is}\|_{\mathcal{L}(L^p(\mathbb{R}^d; X))}. \end{aligned}$$

Step 2: Next we apply the operator $(-\Delta)^{is}$ on $L_0^p(\mathbb{T}^d; X)$ to functions of the first variable only, $f(t) = f_1(t_1)$, where $f_1 \in L_0^p(\mathbb{T}; X)$. These have non-zero Fourier coefficients only for $k = (k_1, 0, \dots, 0)$, in which case $(2\pi|k|)^{i2s} = (2\pi|k_1|)^{i2s}$, and we see that $((-\Delta)^{is}f)(t) = ((-\Delta_1)^{is}f)(t_1)$, where Δ_1 is the one-dimensional Laplacian on \mathbb{T} . Thus

$$\|(-\Delta)^{is}\|_{\mathcal{L}(L_0^p(\mathbb{T}; X))} \leq \|(-\Delta)^{is}\|_{\mathcal{L}(L_0^p(\mathbb{T}^d; X))}.$$

Combining the above displayed estimates with Theorem 10.5.1 gives the statement of the corollary. □

The proof of Theorem 10.5.1 is based on the fact that the values of the multiplier $|\xi|^{is}$ provide good approximations of any prescribed numbers $|\epsilon_k| = 1$ on long intervals $I_k \ni \xi$:

Lemma 10.5.3. *Given a sequence $s_j \downarrow 0$, numbers $\delta > 0$ and $L \geq 2$, and complex signs $|\epsilon_k| = 1$ for $1 \leq k \leq K$, we can find integers $N_0 = 0 < N_1 < N_2 < \dots < N_K$ and $s = s_j$ in such a way that*

$$||\xi|^{is} - \epsilon_k| \leq \delta \quad \forall \xi \in I_k := [N_k - LN_{k-1}, LN_k], \quad k = 1, \dots, K.$$

Proof. For $\xi \in I_k$, we have

$$\log |\xi| - \log N_k \in \left[\log\left(1 - \frac{LN_{k-1}}{N_k}\right), \log L \right] \subseteq \left[\log \frac{1}{2}, \log L \right] \subseteq \left[-\frac{\delta}{2s}, \frac{\delta}{2s} \right],$$

provided that $N_k > 2LN_{k-1}$ and $s = s_j$ is small enough, depending only on L (indeed, we need $s \leq \delta/(2 \log L)$). We fix such an s , and proceed to specify the choice of N_k .

Let $N_0 := 0$. Assuming that N_{k-1} is already chosen, the choice of N_k is as follows. Write $\epsilon_k = e^{it_k}$. Since $(\log n)_{n \geq 1}$ increases to ∞ with decreasing steps $\log(n+1) - \log n \leq \frac{1}{n} \rightarrow 0$, we find that $s \log n$ comes infinitely often arbitrarily close to $t_k + 2\pi\mathbb{Z}$. Thus we can pick $N_k > 2LN_{k-1}$ such that

$$|s \log N_k - (t_k + 2\pi m_k)| \leq \delta/2$$

for some $m_k \in \mathbb{Z}$. But then, for $\xi \in I_k$, we have

$$\begin{aligned} ||\xi|^{is} - \epsilon_k| &= |e^{is \log |\xi|} - e^{i(t_k + 2\pi m_k)}| \\ &\leq s |\log |\xi| - \log N_k| + |s \log N_k - (t_k + 2\pi m_k)| \leq \frac{\delta}{2} + \frac{\delta}{2} = \delta. \end{aligned}$$

□

Proof of Theorem 10.5.1. We begin by exactly the same reduction as in the proof of Theorem 5.2.10 (the necessity of UMD for the Hilbert transform’s boundedness); but we repeat this short step for the reader’s convenience: By Theorem 4.2.5 it suffices to estimate the dyadic UMD constant. In order to most conveniently connect this with Fourier analysis, we choose a model of the Rademacher system $(r_k)_{k=1}^n$, where the probability space is $\mathbb{T}^n = \mathbb{T}_1 \times \dots \times \mathbb{T}_n$ (each \mathbb{T}_k is simply an indexed copy of \mathbb{T}), and $r_k = r_k(t_k)$ is a function of the k th coordinate only. Then it is (more than) sufficient to prove that

$$\left\| \sum_{k=1}^n \epsilon_k f_k \right\|_{L^p(\mathbb{T}^n; X)} \leq \liminf_{s \downarrow 0} \|(-\Delta)^{is}\|_{\mathcal{L}(L^p(\mathbb{T}; X))} \left\| \sum_{k=1}^n f_k \right\|_{L^p(\mathbb{T}^n; X)}$$

for all $f_k \in L_0^p(\mathbb{T}_k; L^p(\mathbb{T}^{k-1}; X))$, since in particular each $\phi_k(r_1, \dots, r_{k-1})r_k$ has this form, and the latter are precisely the martingale differences of

Paley–Walsh martingales (see Proposition 3.1.10). We use the convention that $L^p(\mathbb{T}^0; X) := X$. By the density of trigonometric polynomials in L^p , we may further assume that each f_k is a trigonometric polynomial on \mathbb{T}_k , with values in the space of trigonometric polynomials on \mathbb{T}^{k-1} .

Fix some $(t_1, \dots, t_n) \in \mathbb{T}^n$, and denote $\mathbf{t}_k := (t_1, \dots, t_k) \in \mathbb{T}^k$. We also consider integers $0 = N_0 < N_1 < \dots < N_n$, and denote $\mathbf{N}_k := (N_1, \dots, N_k) \in \mathbb{Z}^k$. Since f_k lacks the zeroth frequency as a function of t_k , the function

$$t \in \mathbb{T} \mapsto F_k(t) := f_k(\mathbf{N}_k t + \mathbf{t}_k) = f_k(\mathbf{N}_{k-1} t + \mathbf{t}_{k-1}, N_k t + t_k)$$

has non-zero Fourier coefficients only for frequencies

$$|\xi| \in I_k := [N_k - LN_{k-1}, LN_k],$$

where L is a number depending only on the frequencies of the trigonometric polynomials f_1, \dots, f_n . (By the assumption that $(N_k)_{k=1}^n$ is increasing, we may absorb the dependence on \mathbf{N}_k into a dependence on N_k only.)

Let us denote $\|f\|_A = \|f\|_{A(\mathbb{T}^k; X)} := \sum_{\xi \in \mathbb{Z}^k} \|\widehat{f}(\xi)\|_X$, and observe that $(-\Delta)^{is}$ is the Fourier multiplier with symbol $(2\pi|\xi|)^{i2s} = (2\pi)^{i2s} |\xi|^{i2s}$. If we now choose the integers N_k and the number $s/2 > 0$ (in place of s) as in Lemma 10.5.3, this lemma guarantees that

$$\|(-\Delta)^{is/2} F_k - (2\pi)^{is} \epsilon_k F_k\|_A \leq \delta \|F_k\|_A \leq \delta \|f_k\|_A;$$

indeed, this holds for the trigonometric monomial e_ξ with $|\xi| \in I_k$, and hence for the A -norm of F_k by summing over all $|\xi| \in I_k$.

Thus

$$\left\| \sum_{k=1}^n \epsilon_k F_k \right\|_p = \left\| \sum_{k=1}^n (2\pi)^{is/2} \epsilon_k F_k \right\|_p \leq \left\| \sum_{k=1}^n (-\Delta)^{is/2} F_k \right\|_p + \delta \sum_{k=1}^n \|f_k\|_A$$

and, noting that all F_k have integral zero,

$$\left\| \sum_{k=1}^n (-\Delta)^{is/2} F_k \right\|_p \leq \|(-\Delta)^{is/2}\|_{\mathcal{L}(L^p_0(\mathbb{T}; X))} \left\| \sum_{k=1}^n F_k \right\|_p.$$

Taking the $L^p(\mathbb{T}^n)$ -norms with respect to $\mathbf{t}_n \in \mathbb{T}^n$, we note that

$$\begin{aligned} \left\| \sum_{k=1}^n \epsilon_k F_k \right\|_{L^p(\mathbb{T}^n; L^p(\mathbb{T}; X))} &= \left\| \sum_{k=1}^n \epsilon_k f_k(t\mathbf{N}_k + \mathbf{t}_k) \right\|_{L^p(\mathbb{T}, dt; L^p(\mathbb{T}^n, d\mathbf{t}_n; X))} \\ &= \left\| \sum_{k=1}^n \epsilon_k f_k(\mathbf{t}_k) \right\|_{L^p(\mathbb{T}, dt; L^p(\mathbb{T}^n, d\mathbf{t}_n; X))} = \left\| \sum_{k=1}^n \epsilon_k f_k \right\|_{L^p(\mathbb{T}^n; X)} \end{aligned}$$

by Fubini's theorem and translation invariance of the $L^p(\mathbb{T}^n; X)$ -norm. Substituting back, we have checked that

$$\left\| \sum_{k=1}^n \epsilon_k f_k \right\|_p \leq \|(-\Delta)^{is/2}\|_{\mathcal{L}(L_0^p(\mathbb{T}; X))} \left\| \sum_{k=1}^n f_k \right\|_p + \delta \sum_{k=1}^n \|f_k\|_A.$$

As the only dependence on δ here is the explicit factor in the last term, we may pass to the limit $\delta \rightarrow 0$ to eliminate this term. Finally, we observe that Lemma 10.5.3 allowed us to choose s (and then also $s/2$) as any number from a given sequence $s_j \rightarrow 0$ and hence we may finally pass to the limes inferior along such a sequence to deduce that

$$\left\| \sum_{k=1}^n \epsilon_k f_k \right\|_p \leq \liminf_{s \rightarrow 0} \|(-\Delta)^{is}\|_{\mathcal{L}(L_0^p(\mathbb{T}; X))} \left\| \sum_{k=1}^n f_k \right\|_p,$$

as claimed. □

There is a variant involving R -boundedness and Pisier’s contraction property:

Proposition 10.5.4. *If the operators $(-\Delta)^{is}$ are R -bounded on $L_0^p(\mathbb{T}; X)$ for $s \in (0, 1]$, then X has Pisier’s contraction property, and*

$$\alpha_{p,X} \leq \lim_{t \downarrow 0} \mathcal{R}_p((-\Delta)^{is} : s \in (0, t)).$$

Corollary 10.5.5. *If the operators $(-\Delta)^{is}$ are R -bounded on $L^p(\mathbb{R}^d; X)$ for $s \in (0, 1]$, then X has Pisier’s contraction property, and*

$$\alpha_{p,X} \leq \lim_{t \downarrow 0} \mathcal{R}_p((-\Delta)^{is} : s \in (0, t)).$$

This shows in particular that the assumption that X has Pisier’s contraction property is necessary in Theorem 10.3.4(3).

Proof. The deduction of this corollary from Proposition 10.5.4 via transference is very similar to the deduction of Corollary 10.5.2 from Theorem 10.5.1, e.g. after reformulating the R -boundedness as the boundedness of suitable operator-valued multipliers on L^p -spaces of $\varepsilon_N^p(X)$ -valued functions as in the proof of Proposition 8.3.24. The details are left to the reader. □

For the proof of Proposition 10.5.4, we borrow a piece of ergodic theory:

Lemma 10.5.6. *Let $s_1, \dots, s_n \in \mathbb{R}$ and $\mathbf{1}$ be linearly independent over \mathbb{Q} , and let $\mathbf{s} := (s_1, \dots, s_n)$. Then for every $x \in \mathbb{T}^n$, the orbit $\{x + m\mathbf{s} \pmod{1} : m \in \mathbb{N}\}$ is dense in \mathbb{T}^n .*

Proof. Step 1: A zero/one law. We first check that if a measurable $E \subseteq \mathbb{T}^n$ is invariant under $x \mapsto x + \mathbf{s} \pmod{1}$, then $|E| \in \{0, 1\}$. Indeed, writing the Fourier series of $\mathbf{1}_E(t) = \mathbf{1}_{E+\mathbf{s}}(t) = \mathbf{1}_E(t - \mathbf{s})$ in two ways, we find (with convergence in $L^2(\mathbb{T}^n)$) that

$$\sum_{k \in \mathbb{Z}^n} \widehat{\mathbf{1}}_E(k) e_k(t) = \sum_{k \in \mathbb{Z}^n} \widehat{\mathbf{1}}_E(k) e_k(t - \mathbf{s}) = \sum_{k \in \mathbb{Z}^n} \widehat{\mathbf{1}}_E(k) e^{-i2\pi k \cdot \mathbf{s}} e_k(t),$$

and by the uniqueness of the Fourier series that $\widehat{\mathbf{1}_E}(k)(e^{-i2\pi k \cdot \mathbf{s}} - 1) = 0$ for all $k \in \mathbb{Z}^n$. The second factor vanishes if and only if $k \cdot \mathbf{s}$ is an integer, but the assumed \mathbb{Q} -linear independence of s_1, \dots, s_n and 1 implies that this can only happen when $k = 0$. Hence we conclude that $\widehat{\mathbf{1}_E}(k) = 0$ for all $k \in \mathbb{Z}^n \setminus \{0\}$, and thus $\mathbf{1}_E(t) = \widehat{\mathbf{1}_E}(0)$ is a constant almost everywhere. For an indicator function, this leaves the two options $|E| \in \{0, 1\}$.

Step 2: Density of $x + \mathbb{Z}\mathbf{s}$. Assume for contradiction that $\{x + m\mathbf{s} : m \in \mathbb{Z}\}$, for some $x \in \mathbb{T}^n$, avoids a point $y \in \mathbb{T}^n$ by a positive distance $3\delta > 0$. But then $U := \{x' + m\mathbf{s} : m \in \mathbb{Z}, x' \in B(x, \delta)\}$ avoids $V := \{y' + m\mathbf{s} : m \in \mathbb{Z}, y' \in B(y, \delta)\}$ by a positive distance $\delta > 0$. Clearly both U and V are invariant under $x \mapsto \mathbf{s}$ and measurable with positive measure (as countable unions of balls in \mathbb{T}^n). On the other hand, being disjoint, neither can have full measure in \mathbb{T}^n . But this contradicts the zero/one law just established, thereby showing that $\{x + m\mathbf{s} : m \in \mathbb{Z}\}$ must come arbitrarily close to every $y \in \mathbb{T}^n$.

Step 3: Density of $x + \mathbb{N}\mathbf{s}$ for some x . Fix a point $x_0 \in \mathbb{T}^n$ and let $x_k := x - k\mathbf{s}$ for $k = 0, 1, 2, \dots$. Then there exists a subsequence x_{k_j} with a limit $x_\infty \in \mathbb{T}^n$. We show that $x_\infty + \mathbb{N}\mathbf{s}$ is dense. Let $y \in \mathbb{T}^n$ and $\delta > 0$ be arbitrary. Since $x_0 + \mathbb{Z}\mathbf{s}$ is dense, we can find some $m \in \mathbb{Z}$ such that $x_0 + m\mathbf{s} \in B(y, \delta/2)$. Next, we choose $k = k_j \geq |m|$ so large that $|x_k - x_\infty| \leq \delta/2$. But then $x_\infty + (m+k)\mathbf{s} \in x_\infty + \mathbb{N}\mathbf{s}$ is within $\delta/2$ from $x_k + (m+k)\mathbf{s} = x_0 + m\mathbf{s} \in B(y, \delta/2)$, and hence $x_\infty + \mathbb{N}\mathbf{s}$ comes within distance δ from y . Since δ and y were arbitrary, this proves the density of $x_\infty + \mathbb{N}\mathbf{s}$.

Step 4: Conclusion. If $x \in \mathbb{T}^n$ is the point constructed in Step 3, and $x' \in \mathbb{T}^n$ is arbitrary, then

$$\overline{x' + \mathbb{N}\mathbf{s}} = \overline{(x' - x) + (x + \mathbb{N}\mathbf{s})} = (x' - x) + \overline{x + \mathbb{N}\mathbf{s}} = (x' - x) + \mathbb{T}^n = \mathbb{T}^n,$$

and hence $x' + \mathbb{N}\mathbf{s}$ is also dense. □

Proof of Proposition 10.5.4. Applying the R -boundedness of $(-\Delta)^{is}$ to N functions of the form $f_j = \sum_{k=1}^N \varepsilon'_k e_{n_k} x_{jk}$, we deduce that

$$\begin{aligned} & \left\| \sum_{j,k=1}^N \varepsilon_j \varepsilon'_k e_{n_k} (2\pi |n_k|)^{is_j} x_{jk} \right\|_{L^p(\Omega \times \mathbb{T}; X)} \\ & \leq \mathcal{R}_p((-\Delta)^{is_j/2} : 1 \leq j \leq N) \left\| \sum_{j,k=1}^N \varepsilon_j \varepsilon'_k e_{n_k} x_{jk} \right\|_{L^p(\Omega \times \mathbb{T}; X)}. \end{aligned}$$

Since $(\varepsilon'_k e_{k_j}(t))_{k=1}^N$ and $(\varepsilon'_k)_{k=1}^N$ are equidistributed for each $t \in \mathbb{T}$, we may further eliminate the factors e_{k_j} and the integration over \mathbb{T} in the L^p -norm. Similarly, since $((2\pi)^{is_j} \varepsilon_j)_{j=1}^N$ and $(\varepsilon_j)_{j=1}^N$ are equidistributed, we may also eliminate the factors $(2\pi)^{is_j}$. The resulting estimate is essentially Pisier’s contraction property, up to checking that the factors $|n_k|^{is_j}$ can be chosen to approximate an arbitrary double array of numbers α_{jk} of modulus one.

To this end, we first pick $0 < s_1, \dots, s_n < t$ such that s_1, \dots, s_n and 1 are linearly independent over \mathbb{Q} , and Lemma 10.5.6 applies. We write $\alpha_{jk} = e^{it_{jk}}$

for some $t_{jk} \in \mathbb{T}$. Let $\mathbf{s} := (s_1, \dots, s_n)$, and $\mathbf{t}_k := (t_{1k}, \dots, t_{nk}) \in \mathbb{T}^n$. We want to choose $N_1, \dots, N_n \in \mathbb{Z}_+$ such that

$$|\mathbf{s} \log N_k - \mathbf{t}_k| \leq \delta, \quad k = 1, \dots, n.$$

Let first N'_k be so large that $|\mathbf{s}|/N'_k \leq \delta/2$. Then apply Lemma 10.5.6 to find $n_k \in \mathbb{N}$ such that

$$|\mathbf{s}(\log N'_k + n'_k) - \mathbf{t}_k| \leq \delta/2.$$

Since $\log(n+1) - \log n \leq 1/n \leq 1/N'_k$ for $n \geq N'_k$, we can find an integer $N_k \geq N'_k$ such that $|\log N_k - (\log N'_k + n_k)| \leq 1/N'_k$, and hence

$$\begin{aligned} |\mathbf{s} \log N_k - \mathbf{t}_k| &\leq |\mathbf{s}| |\log N_k - (\log N'_k + n_k)| + |\mathbf{s}(\log N'_k + n'_k) - \mathbf{t}_k| \\ &\leq |\mathbf{s}|/N'_k + \delta/2 \leq \delta/2 + \delta/2 = \delta, \end{aligned}$$

as required.

Now we can estimate

$$\begin{aligned} &\left\| \sum_{j,k=1}^N \varepsilon_j \varepsilon'_k \alpha_{jk} x_{jk} \right\|_{L^p(\Omega; X)} = \left\| \sum_{j,k=1}^N \varepsilon_j \varepsilon'_k e^{it_{jk}} x_{jk} \right\|_{L^p(\Omega; X)} \\ &\leq \left\| \sum_{j,k=1}^N \varepsilon_j \varepsilon'_k |N_k|^{is_j} x_{jk} \right\|_{L^p(\Omega; X)} + \sum_{j,k=1}^N |s_j \log |N_k| - t_{jk}| \|x_{jk}\|_X \\ &\leq \mathcal{R}_p((-\Delta)^{is/2} : 0 < s < t) \left\| \sum_{j,k=1}^N \varepsilon_j \varepsilon'_k x_{jk} \right\|_{L^p(\Omega; X)} + \delta \sum_{j,k=1}^N \|x_{jk}\|_X. \end{aligned}$$

Since $\delta > 0$ and the array $(x_{jk})_{j,k=1}^N$ is arbitrary, we conclude that

$$\alpha_{p,X} \leq \mathcal{R}_p((-\Delta)^{is/2} : 0 < s < t).$$

Finally, $t > 0$ was also arbitrary, so we can pass to the limit $t \downarrow 0$. □

10.6 The bisectorial H^∞ -calculus

In this section we discuss a variant of the H^∞ -calculus for a class of operators, whose spectrum is spread over two opposite sectors of the complex plane. Throughout this chapter we shall work over the complex scalar field.

10.6.a Bisectorial operators

For $0 < \omega < \frac{1}{2}\pi$ we define $\Sigma_\omega^+ := \Sigma_\omega$ and $\Sigma_\omega^- := -\Sigma_\omega$, and

$$\Sigma_\omega^{\text{bi}} := \Sigma_\omega^+ \cup \Sigma_\omega^-.$$

Here, as always, Σ_ω is the open sector about the positive real axis of opening angle ω . The set $\Sigma_\omega^{\text{bi}}$ is called the *bisector* of angle ω .

Definition 10.6.1. A linear operator A on a Banach space X is said to be bisectorial if there exists an $\omega \in (0, \frac{1}{2}\pi)$ such that the spectrum $\sigma(A)$ is contained in $\overline{\Sigma_\omega^{\text{bi}}}$ and

$$M_{\omega,A}^{\text{bi}} := \sup_{z \in \mathbb{C} \setminus \overline{\Sigma_\omega^{\text{bi}}}} \|zR(z, A)\| < \infty.$$

In this situation we say that A is ω -bisectorial. The infimum of all $\omega \in (0, \frac{1}{2}\pi)$ such that A is ω -bisectorial is called the angle of bisectoriality of A and is denoted by $\omega^{\text{bi}}(A)$.

Replacing the uniform boundedness condition on the operators $zR(z, A)$ by an R -boundedness condition we obtain the notion of an R -bisectorial operator; the corresponding R -bounds will be denoted by $M_{\omega,A}^{\text{bi},R}$.

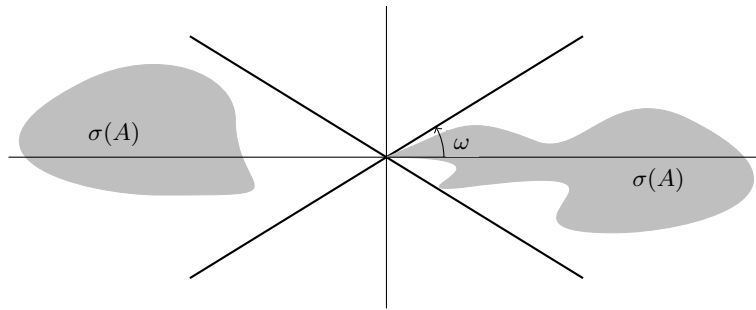

Fig. 10.2: The spectrum of a bisectorial operator

By Proposition 10.1.6 a linear operator A is bisectorial if and only if $i\mathbb{R} \setminus \{0\} \subseteq \varrho(A)$ and

$$\sup_{t \in \mathbb{R}_+ \setminus \{0\}} \|tR(it, A)\| < \infty.$$

Let us record some immediate consequences of the definition.

- An operator A is bisectorial if and only if both operators $\pm iA$ are sectorial.
- A sectorial operator of angle less than $\frac{1}{2}\pi$ is bisectorial of the same angle.
- If A is bisectorial of angle less than $\frac{1}{2}\pi$ and $\sigma(A) \subseteq \overline{\mathbb{C}_+}$, then A is sectorial of the same angle under moderate growth conditions on the resolvent near 0 and infinity. Indeed, by assumption we have uniform bounds for $zR(z, A)$ on appropriate sectors around $\pm i\mathbb{R}$. The remaining uniform bound for $zR(z, A)$ in the remaining sector containing the negative real line follows from this via the sectorial version of the three lines lemma.

In view of these facts it is to be expected that much of the theory of sectorial operators carries over to, or has an analogue for, bisectorial operators. This is indeed the case. In particular this is true for Propositions 10.1.7, 10.1.8, and 10.1.9. Their bisectorial analogues will be used without further comment.

The following result establishes a simple connection between the bisectoriality of an operator A and the sectoriality of its square A^2 .

Proposition 10.6.2. *Let $0 < \sigma < \frac{1}{2}\pi$. If A is σ -bisectorial (resp. σ - R -bisectorial), then:*

(1) A^2 is 2σ -sectorial (resp. 2σ - R -sectorial) and

$$M_{2\sigma, A^2}^{\text{bi}} \leq (M_{\sigma, A})^2 \quad (\text{resp. } M_{2\sigma, A^2}^{\text{bi}, R} \leq (M_{\sigma, A}^R)^2);$$

(2) $\overline{R(A^2)} = \overline{R(A)}$ and $N(A^2) = N(A)$.

Proof. If both $\pm z \in \varrho(A)$, then $z^2 \in \varrho(A^2)$ and

$$(z^2 - A^2)^{-1} = -(z - A)^{-1}(-z - A)^{-1}.$$

The (R -)resolvent bound for A^2 also follows from this identity. This proves (1).

To prove the first assertion in (2) let $x \in \overline{R(A)}$. It follows from (10.5) (noting that iA is sectorial) that $x = \lim_{s \rightarrow 0} A(is + A)^{-1}x = \lim_{s \rightarrow 0} \lim_{t \rightarrow 0} A^2(it + A)^{-1}(is + A)^{-1}x$, so $\overline{R(A)} \subseteq \overline{R(A^2)}$. The reverse inclusion is trivial.

If $x \in N(A^2)$, then by (10.4) (again noting that iA is sectorial), $Ax = \lim_{t \rightarrow 0} (it + A)^{-1}A^2x = 0$, so $N(A^2) \subseteq N(A)$. The reverse inclusion is trivial. \square

Examples

The first example is of abstract nature and plays an important role in the transference results of Section 10.7.b.

Example 10.6.3 (Generators of bounded C_0 -groups). If iA generates a bounded C_0 -group (see Appendix G), then A is bisectorial of angle 0. This is immediate from the easy part of the Hille–Yosida theorem, which provides (after a rotation about $\frac{1}{2}\pi$) the resolvent estimate $\|R(\lambda, iA)\| \leq M_\sigma/|\Re\lambda|$, valid for all $0 < \sigma < \frac{1}{2}\pi$ and $\lambda \in \pm\Sigma_\sigma^{\text{bi}}$.

Example 10.6.4 (The operators $\pm id/dx$). As a special case of the preceding example, the operators $\pm id/dx$ are bisectorial on $L^p(\mathbb{R}; X)$ of angle 0, for all $1 < p < \infty$ and all Banach spaces X .

Example 10.6.5 (The Hodge–Dirac operator). On $L^2(\mathbb{R}^d) \oplus L^2(\mathbb{R}^d; \mathbb{C}^d)$ we consider the operator

$$D := \begin{pmatrix} 0 & \nabla^* \\ \nabla & 0 \end{pmatrix}$$

with its natural domain $D(D) = D(\nabla) \oplus D(\nabla^*)$, where $D(\nabla)$ is the Sobolev space $W^{1,2}(\mathbb{R}^d)$ and $D(\nabla^*)$ is the domain of the Hilbert space adjoint $\nabla^* = -\operatorname{div} \nabla$. Standard arguments show that D is self-adjoint and therefore, by Stone's theorem (Theorem G.6.2), iD generates a unitary C_0 -group. Example 10.6.3 then gives the bisectoriality of D .

The interest of this operator derives from the fact that it “squares to $-\Delta$ ” in the sense that its square is of the form

$$D^2 = \begin{pmatrix} -\Delta & 0 \\ 0 & * \end{pmatrix}.$$

10.6.b Basic theory of the bisectorial calculus

The construction of the Dunford calculus of a bisectorial operator A is analogous to the sectorial case, the only difference being that we replace the Hardy spaces $H^p(\Sigma)$ by their bisectorial counterparts $H^p(\Sigma^{\text{bi}})$, the Banach spaces of all holomorphic functions $f : \Sigma_\sigma^{\pm \text{bi}} \rightarrow \mathbb{C}$ for which the norm

$$\|f\|_{H^p(\Sigma_\sigma^{\text{bi}})} := \sup_{|\nu| < \sigma} \|t \mapsto f(e^{i\nu t})\|_{L^p(\mathbb{R}_+, \frac{dt}{t})}$$

is finite. We define the Dunford integrals by integrating over the boundary of Σ^{bi} . More precisely, for $f \in H^1(\Sigma_\sigma^{\text{bi}})$ with $\omega^{\text{bi}}(A) < \sigma < \frac{1}{2}\pi$ we set

$$f(A) := \int_{\partial \Sigma_\nu^{\text{bi}}} f(z)R(z, A) dz,$$

where $\omega^{\text{bi}}(A) < \nu < \sigma$ is chosen arbitrarily. The path of integration is traversed so that the interior of the two sectors Σ_ν^\pm is always at the left hand. We say that A has a bounded $H^\infty(\Sigma_\sigma^{\text{bi}})$ -calculus if there exists a constant $M \geq 0$ such that

$$\|f(A)\| \leq M \|f\|_\infty \quad f \in H^1(\Sigma_\sigma^{\text{bi}}) \cap H^\infty(\Sigma_\sigma^{\text{bi}}).$$

Proposition 10.2.11 carries over to the bisectorial case *mutatis mutandis*, with only one small difference: we now set

$$\tilde{\zeta}(z) := \frac{z}{z^2 + 1} = \frac{z}{(z + i)(z - i)},$$

then check that $\tilde{\zeta}(A) = A(A + i)^{-1}(A - i)^{-1}$ and define, for $f \in H^\infty(\Sigma_\sigma^{\text{bi}})$ and $x \in D(A) \cap R(A)$, say $x = \tilde{\zeta}(A)y$,

$$\Psi_A(f)x := (f\tilde{\zeta})(A)y.$$

Proposition 10.6.6. *Let A be a bisectorial operator on X and let $\omega^{\text{bi}}(A) < \sigma < \frac{1}{2}\pi$. Let $C > 0$. The following assertions are equivalent:*

- (1) A has a bounded $H^\infty(\Sigma_\sigma^{\text{bi}})$ -calculus;

(2) there is a constant $C \geq 0$ such that for all $f \in H^1(\Sigma_\sigma^{\text{bi}}) \cap H^\infty(\Sigma_\sigma^{\text{bi}})$,

$$\|f(A)x\| \leq C\|f\|_\infty\|x\|, \quad x \in \text{D}(A) \cap \text{R}(A);$$

(3) there is a constant $C \geq 0$ such that for all $f \in H^\infty(\Sigma_\sigma^{\text{bi}})$,

$$\|\Psi_A(f)x\| \leq C\|f\|_\infty\|x\|, \quad x \in \text{D}(A) \cap \text{R}(A).$$

Moreover, analogous relations between the best constants hold. The best constant in (3) is denoted by $M_{\sigma,A}^{\text{bi},\infty}$.

As in the sectorial case the operators $\Psi_A(f)$ map $\overline{\text{D}(A) \cap \text{R}(A)}$ into itself and the resulting mapping

$$\Psi_A : H^\infty(\Sigma_\sigma^{\text{bi}}) \mapsto \mathcal{L}(\overline{\text{D}(A) \cap \text{R}(A)})$$

is called the $H^\infty(\Sigma_\sigma^{\text{bi}})$ -calculus of A . It shares the properties collected in Theorem 10.2.13: the calculus is additive, for $x \in \text{D}(A) \cap \text{R}(A)$ we have

$$\mathbf{1}(A)x = x \quad \text{and} \quad r_\mu(A)x = R(\mu, A)x$$

for $r_\mu(z) = (\mu - z)^{-1}$ and $\mu \in \mathbb{C} \setminus \overline{\Sigma_\sigma^{\text{bi}}}$, and it enjoys the bisectorial analogue of the convergence property (10.16). These properties will be used in the sequel without further comment.

The next theorem establishes an important connection between the H^∞ -calculi of a bisectorial operator A and the sectorial operator A^2 . The proof makes use of the fact, which we leave to the reader to verify, that the square function characterisations of the H^∞ -calculus of Section 10.4 carry over to the bisectorial case *mutatis mutandis*. In the present chapter we will only need the elementary part of the theorem, which is the implication (1) \Rightarrow (2). The power of the theorem, however, resides in the implication (2) \Rightarrow (1), which often allows one to study Riesz transforms by means of functional calculus methods.

Theorem 10.6.7. *Let A be an R -bisectorial operator on a Banach space. Then A^2 is R -sectorial, and for all $\omega^{\text{bi}}(A) < \sigma < \frac{1}{2}\pi$ the following assertions hold:*

- (1) *if A admits a bounded $H^\infty(\Sigma_\sigma^{\text{bi}})$ -calculus, then A^2 admits a bounded $H^\infty(\Sigma_{2\sigma})$ -calculus and $M_{2\sigma,A^2}^{\text{bi},\infty} \leq M_{\sigma,A}^\infty$;*
- (2) *if A^2 admits a bounded $H^\infty(\Sigma_{2\sigma})$ -calculus, then A admits a bounded $H^\infty(\Sigma_\vartheta^{\text{bi}})$ -calculus for all $\sigma < \vartheta < \pi$.*

Proof. The R -sectoriality of A^2 with angle $2\omega_R(A)$ has already been observed in Proposition 10.6.2.

(1): To see that A^2 admits a bounded $H^\infty(\Sigma_{2\sigma})$ -calculus, let $f \in H^1(\Sigma_{2\sigma}) \cap H^\infty(\Sigma_{2\sigma})$ be given and compute

$$\begin{aligned}
 f(A^2) &= \frac{1}{2\pi i} \int_{\partial\Sigma_{2\nu}^+} f(z)R(z, A^2) dz \\
 &= \frac{1}{2\pi i} \int_{\partial\Sigma_\nu^+} f(w^2)R(w^2, A^2)2w dw \\
 &= \frac{1}{2\pi i} \int_{\partial\Sigma_\nu^+} f(w^2)[R(w, A) - R(-w, A)] dw \\
 &= \frac{1}{2\pi i} \int_{\partial\Sigma_\nu^{\text{bi}}} f(w^2)R(w, A) dw = \tilde{f}(A),
 \end{aligned} \tag{10.42}$$

where $\tilde{f}(z) := f(z^2)$. Thus

$$\|f(A^2)\|_{\mathcal{L}(X)} = \|\tilde{f}(A)\|_{\mathcal{L}(X)} \leq M_{\nu, A}^\infty \|\tilde{f}\|_{H^\infty(\Sigma_\nu^{\text{bi}})} = M_{\nu, A}^\infty \|f\|_{H^\infty(\Sigma_{2\nu}^+)}.$$

It follows that A^2 has a bounded $H^\infty(\Sigma_{2\sigma})$ -calculus. By Letting $\nu \uparrow \sigma$, this also gives the bound on the constants.

(2): Fix an arbitrary non-zero function $g \in H^1(\Sigma_{2\vartheta}) \cap H^\infty(\Sigma_{2\vartheta})$ with $\sigma < \vartheta < \pi$, and define $\tilde{g} \in H^1(\Sigma_\vartheta^{\text{bi}}) \cap H^\infty(\Sigma_\vartheta^{\text{bi}})$ by $\tilde{g}(z) := g(z^2)$. Then \tilde{g} is non-zero on both Σ_ϑ^\pm .

Since A^2 has a bounded $H^\infty(\Sigma_{2\sigma})$ -functional calculus, by Theorem 10.4.4 it satisfies a discrete square function estimate

$$\sup_{t>0} \sup_{N \geq 1} \left(\mathbb{E} \left\| \sum_{|n| \leq N} \varepsilon_n g(2^n t A^2) x \right\|^2 \right)^{1/2} \approx \|x\|$$

for $x \in \overline{\mathbb{R}(A^2) \cap \mathbb{D}(A^2)} = \overline{\mathbb{R}(A) \cap \mathbb{D}(A)}$. By (10.42) we have $g(tA^2) = \tilde{g}(\sqrt{t}A)$, and therefore by the substitution $\sqrt{t} = s$ the above estimate is equivalent to

$$\sup_{s>0} \sup_{N \geq 1} \left(\mathbb{E} \left\| \sum_{|n| \leq N} \varepsilon_n \tilde{g}(\sqrt{2}^n s A) x \right\|^2 \right)^{1/2} \approx \|x\|$$

for $x \in \overline{\mathbb{R}(A^2) \cap \mathbb{D}(A^2)} = \overline{\mathbb{R}(A) \cap \mathbb{D}(A)}$. By the bisectorial version of Theorem 10.4.9, this estimate implies that A has a bounded $H^\infty(\Sigma_\sigma^{\text{bi}})$ -calculus. \square

10.7 Functional calculus for (semi)group generators

Having studied the properties of the H^∞ -calculus in fair detail from an abstract point of view, in this final section of this chapter we turn to some concrete situations where the boundedness of the H^∞ -calculus can actually be verified. As we shall see, this often involves importing deep results from other areas of analysis. This should not come as a surprise, since after all proving the boundedness of the H^∞ -calculus is tantamount to controlling singular integrals. We have already seen one explicit instance when we deduced the boundedness of the H^∞ -calculus for the Laplace operator on $L^p(\mathbb{R}^d)$, $1 < p < \infty$, from the Mihlin multiplier theorem. From this point of view the highlights of this section will be the following results:

- if iA is the generator of a uniformly bounded C_0 -group on a UMD Banach space X , then A has a bounded bisectorial H^∞ -calculus of angle 0 (Theorem 10.7.10).
- if $-A$ is the generator of a positive C_0 -semigroup of contractions on an L^p -space with $1 < p < \infty$, then A has a bounded H^∞ -calculus of angle $\leq \frac{1}{2}\pi$ (Theorem 10.7.12).
- if $-A$ is the generator of a positive C_0 -semigroup of contractions on an L^p -space with $1 < p < \infty$, and if this semigroup is bounded and holomorphic on a sector of angle $\eta \in (0, \frac{1}{2}\pi)$, then A has a bounded H^∞ -calculus of angle $\leq \frac{1}{2}\pi - \frac{1}{2}\eta(p \wedge p')$ (Theorem 10.7.13).

The proofs of these theorems depend on transference techniques due to Coifman and Weiss in combination with, respectively, (a special case of) the Akcoglu–Sucheston dilation theorem for positive contractions on L^p -spaces, Akcoglu’s pointwise maximal ergodic theorem for positive contractions on L^p -spaces, and complex interpolation of the spaces $L^p(S; \ell_n^q)$.

10.7.a The Phillips calculus

For generators of (semi)groups, another useful functional calculus, besides that of Dunford, can be defined as follows:

Definition 10.7.1 (Phillips calculus). *Let X be a Banach space and A be an operator in X .*

(1) *If iA generates a bounded C_0 -group $(U(t))_{t \in \mathbb{R}}$ on X , we define*

$$\Phi_g(A)x := \int_{-\infty}^{\infty} g(t)U(t)x \, dt, \quad g \in L^1(\mathbb{R}), \, x \in X.$$

(2) *If $-A$ generates a bounded C_0 -semigroup $(S(t))_{t \geq 0}$ on X , we define*

$$\Phi_g^+(A)x := \int_0^{\infty} g(t)S(t)x \, dt, \quad g \in L^1(\mathbb{R}_+), \, x \in X.$$

It is immediate that the integrals exist and

$$\begin{aligned} \|\Phi_g(A)\|_{\mathcal{L}(X)} &\leq \|g\|_{L^1(\mathbb{R})} \sup_{t \in \mathbb{R}} \|U(t)\|_{\mathcal{L}(X)}, \\ \|\Phi_g^+(A)\|_{\mathcal{L}(X)} &\leq \|g\|_{L^1(\mathbb{R}_+)} \sup_{t \in \mathbb{R}_+} \|S(t)\|_{\mathcal{L}(X)}. \end{aligned} \tag{10.43}$$

As in the case of the H^∞ calculus, the principal interest is in achieving such estimates for other function classes in place of L^1 . This question will be considered in the rest of this chapter. First, however, we would like to relate the Phillips calculus to the Dunford calculus:

Proposition 10.7.2. *Let X be a Banach space and A be an operator in X .*

(1) If iA generates a bounded C_0 -group $(U(t))_{t \in \mathbb{R}}$ on X , then

$$f(A) = \Phi_{g_f}(A) \quad \text{for all } f \in H^1(\Sigma_\sigma^{\text{bi}}), \quad 0 < \sigma < \frac{1}{2}\pi,$$

where

$$g_f(t) := \begin{cases} \frac{1}{2\pi i} \int_{\partial \Sigma_{\frac{1}{2}\pi-\nu}^-} e^{zt} f(iz) \, dz, & t > 0, \\ -\frac{1}{2\pi i} \int_{\partial \Sigma_{\frac{1}{2}\pi-\nu}^+} e^{zt} f(iz) \, dz, & t < 0, \end{cases} \quad (10.44)$$

satisfies $\|g_f\|_{L^1(\mathbb{R})} \leq (\pi \sin \sigma)^{-1} \|f\|_{H^1(\Sigma_\sigma^{\text{bi}})}$.

(2) If $-A$ generates a bounded C_0 -semigroup $(S(t))_{t \in \mathbb{R}}$ on X , then

$$f(A) = \Phi_{g_f^+}(A) \quad \text{for all } f \in H^1(\Sigma_\sigma), \quad \frac{1}{2}\pi < \sigma < \pi,$$

where

$$g_f(t) := -\frac{1}{2\pi i} \int_{\partial \Sigma_\nu} e^{zt} f(z) \, dz, \quad t > 0, \quad (10.45)$$

satisfies $\|g_f\|_{L^1(\mathbb{R})} \leq (2\pi \sin \sigma)^{-1} \|f\|_{H^1(\Sigma_\sigma)}$.

Proof. (1): It follows from the assumption that A is bisectorial of angle 0. Hence for $0 < \sigma < \frac{1}{2}\pi$ and $f \in H^1(\Sigma_\sigma^{\text{bi}})$ the Dunford integral

$$f(A)x = \frac{1}{2\pi i} \int_{\partial \Sigma_\nu^{\text{bi}}} f(z) R(z, A)x \, dz, \quad x \in X,$$

is well defined; here $0 < \nu < \sigma$ is arbitrary and $\partial \Sigma_\nu$ is oriented in such a way that Σ_ν is on the left-hand side when traversing it.

First substituting $z = i\zeta$, then using the representation of the resolvent of a semigroup generator as the Laplace transform of the semigroup (Proposition G.4.1) and Fubini's theorem (the use of which will be justified shortly), for all $x \in X$ we obtain

$$\begin{aligned} f(A)x &= \frac{1}{2\pi} \int_{-\partial \Sigma_\nu^{\text{bi}}} f(i\zeta) R(i\zeta, A)x \, d\zeta \\ &\stackrel{(*)}{=} -\frac{1}{2\pi i} \int_{\partial \Sigma_{\frac{1}{2}\pi-\nu}^+} f(i\zeta) (\zeta + iA)^{-1} x \, d\zeta \\ &\quad - \frac{1}{2\pi i} \int_{\partial \Sigma_{\frac{1}{2}\pi-\nu}^-} f(i\zeta) (\zeta + iA)^{-1} x \, d\zeta \\ &\stackrel{(**)}{=} -\frac{1}{2\pi i} \int_{\partial \Sigma_{\frac{1}{2}\pi-\nu}^+} f(i\zeta) \int_0^\infty e^{-\zeta t} U(-t)x \, dt \, d\zeta \\ &\quad + \frac{1}{2\pi i} \int_{\partial \Sigma_{\frac{1}{2}\pi-\nu}^-} f(i\zeta) \int_0^\infty e^{\zeta t} U(t)x \, dt \, d\zeta \end{aligned}$$

$$= \int_{-\infty}^{\infty} g_f(t) U(t)x \, dt = \Phi_{g_f}(A)x.$$

In (*) we used that $-i\partial\Sigma_\nu^{\text{bi}} = -(\partial\Sigma_\nu^+ + \partial\Sigma_\nu^-)$, and in (***) that $-iA$ generates the C_0 -group $(U(-t))_{t \in \mathbb{R}}$. Note that

$$\begin{aligned} \int_0^\infty |g_f(t)| \, dt &\leq \frac{1}{2\pi} \int_{\partial\Sigma_{\frac{1}{2}\pi-\nu}^-} \int_0^\infty e^{\Re z t} |f(iz)| \, dt \, |dz| \\ &= \frac{1}{2\pi} \int_{\partial\Sigma_{\frac{1}{2}\pi-\nu}^-} |f(iz)| \frac{|dz|}{|\Re z|} = \frac{1}{2\pi \sin \nu} \int_{\partial\Sigma_{\frac{1}{2}\pi-\nu}^-} |f(iz)| \frac{|dz|}{|z|} \end{aligned}$$

and likewise

$$\int_{-\infty}^0 |g_f(t)| \, dt \leq \frac{1}{2\pi \sin \nu} \int_{\partial\Sigma_{\frac{1}{2}\pi-\nu}^+} |f(iz)| \frac{|dz|}{|z|}.$$

It follows that $g_f \in L^1(\mathbb{R})$ and, letting $\nu \rightarrow \sigma$, that $\|g_f\|_1 \leq \frac{1}{\pi \sin \sigma} \|f\|_{H^1(\Sigma_\sigma^{\text{bi}})}$; at the same time this justifies the above use of Fubini's theorem.

(2): Now A is sectorial of angle $\frac{1}{2}\pi$. Proceeding as in the bisectorial case, an easy estimate shows that $g_f^+ \in L^1(\mathbb{R}_+)$ with $\|g_f^+\|_{L^1(\mathbb{R}_+)} \leq \frac{1}{2\pi \cos \sigma} \|f\|_{H^1(\Sigma_\sigma)}$, and using Fubini's theorem with $\frac{1}{2}\pi < \nu < \sigma$ we obtain

$$\begin{aligned} \int_0^\infty g_f(t) S(t)x \, dt &= -\frac{1}{2\pi i} \int_0^\infty \int_{\partial\Sigma_\nu} e^{zt} f(z) S(t)x \, dz \, dt \\ &= -\frac{1}{2\pi i} \int_{\partial\Sigma_\nu} f(z) \int_0^\infty e^{zt} S(t)x \, dt \, dz \\ &= -\frac{1}{2\pi i} \int_{\partial\Sigma_\nu} f(z) R(-z, -A)x \, dz \\ &= \frac{1}{2\pi i} \int_{\partial\Sigma_\nu} f(z) R(z, A)x \, dz = f(A)x. \end{aligned}$$

as desired. \square

The relation of the functions g_f and g_f^+ with f is most conveniently expressed in terms of the Fourier transform:

Lemma 10.7.3. *Under the assumptions of Proposition 10.7.2, we have*

$$\widehat{g}_f(\xi) = f(-2\pi i\xi), \quad \widehat{g}_f^+(\xi) = -f(2\pi i\xi).$$

Proof. The Fourier transform of g_f is easily computed: for $\xi \neq 0$ we have

$$\widehat{g}_f(\xi) = \frac{1}{2\pi i} \int_{\partial\Sigma_{\frac{1}{2}\pi-\nu}^-} \int_0^\infty e^{-2\pi i t \xi} e^{zt} f(iz) \, dt \, dz$$

$$\begin{aligned}
 & -\frac{1}{2\pi i} \int_{\partial\Sigma_{\frac{1}{2}\pi-\nu}^+} \int_{-\infty}^0 e^{-2\pi i t \xi} e^{zt} f(iz) dt dz \\
 &= \frac{1}{2\pi i} \int_{\partial\Sigma_{\frac{1}{2}\pi-\nu}^-} \frac{1}{2\pi i \xi - z} f(iz) dz + \frac{1}{2\pi i} \int_{\partial\Sigma_{\frac{1}{2}\pi-\nu}^+} \frac{1}{2\pi i \xi - z} f(iz) dz \\
 &= \frac{1}{2\pi i} \int_{\partial\Sigma_{\nu}^-} \frac{1}{2\pi \xi + \zeta} f(\zeta) d\zeta + \frac{1}{2\pi i} \int_{\partial\Sigma_{\nu}^+} \frac{1}{2\pi \xi + \zeta} f(\zeta) d\zeta \\
 &= f(-2\pi \xi),
 \end{aligned}$$

using Cauchy’s theorem in the last step, noting that one integral gives $f(-2\pi\xi)$ and the other 0.

Similarly, for $\xi \neq 0$ we have

$$\begin{aligned}
 \widehat{g}_f^+(\xi) &= \frac{1}{2\pi i} \int_{\partial\Sigma_{\nu}^-} \int_0^{\infty} e^{-2\pi i t \xi} e^{zt} f(z) dt dz \\
 &= \frac{1}{2\pi i} \int_{\partial\Sigma_{\nu}^-} \frac{1}{2\pi i \xi - z} f(z) dz \\
 &= -f(2\pi i \xi)
 \end{aligned}$$

by Cauchy’s theorem, keeping in mind that $\frac{1}{2}\pi < \nu < \pi$ in this case. □

We record an estimate that will play a role in an application of the Mihlin multiplier theorem (Corollary 8.3.11) further below.

Lemma 10.7.4. *If $f \in H^1(\Sigma_{\sigma}^{\text{bi}}) \cap H^{\infty}(\Sigma_{\sigma}^{\text{bi}})$ with $0 < \sigma < \frac{1}{2}\pi$, then the function g_f of (10.44) satisfies*

$$\sup_{\xi \in \mathbb{R} \setminus \{0\}} \max\{|\widehat{g}_f(\xi)|, |\xi \widehat{g}'_f(\xi)|\} \leq \frac{1}{\sin \sigma} \|f\|_{H^{\infty}(\Sigma_{\sigma}^{\text{bi}})}.$$

If $f \in H^1(\Sigma_{\sigma}) \cap H^{\infty}(\Sigma_{\sigma})$ with $\frac{1}{2}\pi < \sigma < \pi$, then the function g_f^+ of (10.45) satisfies

$$\sup_{\xi \in \mathbb{R} \setminus \{0\}} \max\{|\widehat{g}_f^+(\xi)|, |\xi (\widehat{g}_f^+)'(\xi)|\} \leq \frac{1}{\cos \sigma} \|f\|_{H^{\infty}(\Sigma_{\sigma}^{\text{bi}})}.$$

Proof. The claimed estimates, even with better constant 1, for $|\widehat{g}_f(\xi)|$ and $|\widehat{g}_f^+(\xi)|$ follow at once from Lemma 10.7.3.

Concerning the derivative, we can use Cauchy’s theorem to write

$$|f(z)| = \left| \frac{-1}{2\pi i} \oint_{\partial D(z,r)} \frac{f(w)}{(z-w)^2} dw \right| \leq \frac{1}{2\pi} \frac{\|f\|_{\infty}}{r^2} 2\pi r = \frac{\|f\|_{\infty}}{r},$$

whenever the disc $D(z, r)$ is in the domain of f . In the first case, we are concerned with $z = -2\pi\xi \in \mathbb{R}$ and we can take $r \rightarrow |z| \sin \sigma$; in the second case, we have $z = i2\pi\xi \in i\mathbb{R}$ and we can take $r \rightarrow |z| \cos \sigma$. Noting the cancellation of the factor $2\pi|\xi|$ appearing in both the numerator and the denominator, we obtain the claimed result. □

10.7.b Coifman–Weiss transference theorems

Given $g \in L^1(\mathbb{R})$, we define the convolution operator $K_g : L^p(\mathbb{R}; X) \rightarrow L^p(\mathbb{R}; X)$ for $1 \leq p < \infty$ by

$$K_g f(t) := \int_{-\infty}^{\infty} g(s) f(t-s) ds, \quad f \in L^p(\mathbb{R}; X). \quad (10.46)$$

With the help of Young's inequality one checks that

$$\|K_g\|_{\mathcal{L}(L^p(\mathbb{R}; X))} \leq \|g\|_1. \quad (10.47)$$

Theorem 10.7.5 (Coifman–Weiss, transference for bounded groups).

Let iA be the generator of a uniformly bounded C_0 -group $(U(t))_{t \in \mathbb{R}}$ on a Banach space X and let $g \in L^1(\mathbb{R})$. Then for all $p \in [1, \infty)$, the Phillips calculus satisfies

$$\|\Phi_g(A)\|_{\mathcal{L}(X)} \leq \|K_g\|_{\mathcal{L}(L^p(\mathbb{R}; X))} \sup_{t \in \mathbb{R}} \|U(t)\|_{\mathcal{L}(X)}^2.$$

The point of the theorem is to “transfer” an estimate on K_g to an estimate on $\Phi_g(A)$. Of course one always has the elementary estimate in (10.43) involving $\|g\|_{L^1(\mathbb{R})}$ but the theorem often provides a better estimate in situations where we can estimate $\|K_g\|_{\mathcal{L}(L^p(\mathbb{R}; X))}$ in a more clever way.

Example 10.7.6. Let X be Hilbert space and $p = 2$. From Parseval's identity we obtain

$$\|K_g\|_{\mathcal{L}(L^2(\mathbb{R}; X))} = \sup_{s \in \mathbb{R}} |\widehat{g}(s)|.$$

Theorem 10.7.10 will present a second example. These improvements over the first inequality in (10.43) are essential in many applications.

Proof of Theorem 10.7.5. Set $\|U\|_\infty := \sup_{t \in \mathbb{R}} \|U(t)\|$. By estimates (10.47) and (10.43), and density in $L^1(\mathbb{R})$, without loss of generality we may assume that g has support in interval $[-N, N]$, say. Given $\varepsilon > 0$, we choose M so large that $\frac{M+N}{M} \leq 1 + \varepsilon$. Since $(U(t))^{-1} = U(-t)$ we have, for all $y \in X$,

$$\|y\| \leq \|U\|_\infty \|U(-t)y\|.$$

Applying this with $y = \Phi_g(A)x$, by averaging we obtain

$$\begin{aligned} \|\Phi_g(A)x\|^p &\leq \frac{\|U\|_\infty^p}{2M} \int_{-M}^M \|U(-s)\Phi_g(A)x\|^p ds \\ &= \frac{\|U\|_\infty^p}{2M} \int_{-M}^M \left\| \int_{-\infty}^{\infty} g(t)U(t-s)x dt \right\|^p ds \end{aligned}$$

by the definition of $\Phi_g(A)$. Also $\mathbf{1}_{[-M-N, M+N]}(t-s) = 1$ if $t \in \text{supp } g \subseteq [-N, N]$ and $s \in [-M, M]$, so that with $\chi := \mathbf{1}_{[-M-N, M+N]}$ the last expression can be rewritten as

$$= \frac{\|U\|_\infty^p}{2M} \int_{-M}^M \left\| \int_{-\infty}^\infty g(t) [U(t-s)x \chi(t-s)] dt \right\|^p ds$$

and, by the definition of K_g ,

$$\begin{aligned} &= \frac{\|U\|_\infty^p}{2M} \int_{-M}^M \|K_g[U(\cdot)x \chi(\cdot)](s)\|^p ds \\ &\leq \frac{\|U\|_\infty^p}{2M} \|K_g[U(\cdot)x \chi(\cdot)]\|_{L^p(\mathbb{R}; X)}^p \\ &\leq \frac{\|U\|_\infty^p}{2M} \|K_g\|_{\mathcal{L}(L^p(\mathbb{R}; X))}^p \int_{-\infty}^\infty \|U(s)x \chi(s)\|^p ds \\ &= \frac{\|U\|_\infty^p}{2M} \|K_g\|_{\mathcal{L}(L^p(\mathbb{R}; X))}^p \int_{-N-M}^{N+M} \|U(s)x\|^p ds \\ &\leq \frac{\|U\|_\infty^p}{2M} \|K_g\|_{\mathcal{L}(L^p(\mathbb{R}; X))}^p 2(N+M) \|U\|_\infty^p \|x\|^p \\ &\leq (1+\varepsilon) \|U\|_\infty^{2p} \|K_g\|_{\mathcal{L}(L^p(\mathbb{R}; X))}^p \|x\|^p \end{aligned}$$

and the claim follows. □

Remark 10.7.7. In exactly the same way one proves the following discrete version of the theorem which will be needed shortly: if U is an invertible operator on a Banach space X satisfying $\sup_{n \in \mathbb{Z}} \|U^n\| < \infty$, then for all $a \in \ell^1(\mathbb{Z})$ we have

$$\left\| \sum_{n \in \mathbb{Z}} a_n U^n \right\|_{\mathcal{L}(X)} \leq \|\kappa_a\|_{\mathcal{L}(\ell^p(\mathbb{Z}; X))} \sup_{n \in \mathbb{Z}} \|U^n\|^2,$$

where κ_a is the convolution operator on $\ell^p_{\mathbb{Z}}$ given by $(\kappa_a c)_n := \sum_{k \in \mathbb{Z}} a_k c_{n-k}$.

Coifman–Weiss transference for positive contractions

In the rest of this subsection, we consider another version of the Coifman–Weiss transference. This will require some preparation.

Given a sequence $a = (a_n)_{n \in \mathbb{Z}} \in \ell^1(\mathbb{Z})$, we denote by κ_a the corresponding convolution operator on $\ell^p(\mathbb{Z}; X)$, $1 \leq p \leq \infty$, i.e., for $c = (c_n)_{n \in \mathbb{Z}} \in \ell^p(\mathbb{Z}; X)$ we set

$$(\kappa_a c)_n := \sum_{k \in \mathbb{Z}} a_k c_{n-k}.$$

By Young’s inequality, $\|\kappa_a\|_{\mathcal{L}(\ell^p(\mathbb{Z}; X))} \leq \|a\|_{\ell^1(\mathbb{Z})}$. In what follows, sequences $(a_n)_{n \geq 0} \in \ell^1(\mathbb{N})$ will be identified with sequences $(a_n)_{n \in \mathbb{Z}} \in \ell^1(\mathbb{Z})$ in the natural way by taking $a_{-n} = 0$ for $n \geq 1$.

Proposition 10.7.8. *Let (S, \mathcal{A}, μ) be a measure space, $p \in (1, \infty)$, and $T \in \mathcal{L}(L^p(S))$ be a positive contraction. Then for every $a \in \ell^1(\mathbb{N})$ and every Banach space X we have*

$$\left\| \sum_{n \geq 0} a_n T^n \right\|_{\mathcal{L}(L^p(S; X))} \leq \|\kappa_a\|_{\mathcal{L}(\ell^p(\mathbb{Z}; X))}.$$

Proof. By Theorem 2.1.3, T extends to a contraction on $L^p(S; X)$. Since both sides of the bound are dominated by $\|a\|_{\ell^1}$, by approximation, in the rest of the proof we may assume that a is finitely supported.

Step 1 – First we consider the situation that (S, \mathcal{A}, μ) is a measure space having a finite number of points and μ gives mass 1 to every point. Then $L^p(S)$ may be identified with ℓ_n^p , where n is the number of points. By the Akcoglu–Sucheston Dilation Theorem I.1.2, there is a positive, invertible, isometric $U \in L^p(D)$, for some measure space D , as well as a positive isometric embedding $J : \ell_n^p \rightarrow L^p(D)$ and a positive surjective contraction $P : L^p(D) \rightarrow \mathcal{R}(J)$ such that

$$T^k = J^{-1} P U^k J \quad \text{for all } k = 0, 1, 2, \dots$$

Since all operators are positive, this identity extends to $\ell_n^p(X)$. Hence

$$\begin{aligned} \left\| \sum_{k \geq 0} a_k T^k \right\|_{\mathcal{L}(\ell_n^p(X))} &= \left\| J^{-1} P \sum_{k \geq 0} a_k U^k J \right\|_{\mathcal{L}(\ell_n^p(X))} \\ &\leq \|J^{-1} P\|_{\mathcal{L}(L^p(D; X), \ell_n^p(X))} \left\| \sum_{k \geq 0} a_k U^k \right\|_{\mathcal{L}(L^p(D; X))} \|J\|_{\mathcal{L}(\ell_n^p(X), L^p(D; X))} \\ &\leq 1 \cdot \|\kappa_a\|_{\mathcal{L}(\ell^p(\mathbb{Z}))} \cdot 1, \end{aligned}$$

where the last step used the following results: For the middle factor, this was an application of Theorem 10.7.5 and Remark 10.7.7. For the other two factors, the bounds are guaranteed by Theorem I.1.2 when $X = \mathbb{K}$, and they follow from this and the positivity for general X via Theorem 2.1.3.

Step 2 – We suppose again that (S, \mathcal{A}, μ) consists of finitely many points, but drop the assumption that μ assigns equal mass to each of them. After deleting the points of zero mass, we may assume that all points have strictly positive mass. Denoting by ν the measure that gives mass one to each point, we obtain an isometric isomorphism $L^p(S, \mu; X) \simeq L^p(S, \nu; X)$ by sending $f \in L^p(S, \mu; X)$ to the function $\tilde{f} \in L^p(S, \nu; X)$ given by $\tilde{f}(s) := \mu(\{s\})^{1/p} f(s)$. Along this isomorphism, T can be identified with a positive contraction \tilde{T} on $L^p(S, \nu)$. The result now follows from Step 1.

Step 3 – Now let (S, \mathcal{A}, μ) be an arbitrary measure space and fix a function $f \in L^p(S; X)$. Since each of the functions $T^n f$ can be approximated by μ -simple functions, in proving the estimate

$$\left\| \sum_{n \geq 0} a_n T^n f \right\| \leq \|\kappa_a\|_{\ell^p(\mathbb{Z})} \|f\|$$

we may replace the σ -algebra \mathcal{A} by the σ -algebra generated by the countably many sets of finite μ -measure involved in the above-mentioned approximation of the functions $T^n f$, $n \geq 0$. Let $(A_j)_{j \geq 1}$ be an enumeration of these sets.

Thus, we may assume that $\mu(A_j) < \infty$ for all $j \geq 1$ and that \mathcal{A} is generated by the sets $A_j, j \geq 1$.

For each $k \geq 1$, let \mathbb{E}_k denote the conditional expectation in $L^p(S)$ associated with the finite σ -algebra \mathcal{A}_k generated by the sets A_1, \dots, A_k . The operator $T_k := \mathbb{E}_k \circ T$ restricts to a positive contraction on $L^p(S, \mathcal{A}_k)$. Up to a set of μ -measure zero, every set in the finite σ -algebra \mathcal{A}_k is a finite union of atoms of finite and strictly positive μ -measure, and therefore Step 2 gives us the inequality

$$\left\| \sum_{n \geq 0} a_n T_k^n f \right\|_{L^p(S; X)} \leq \|\kappa_a\|_{\mathcal{L}(\ell^p(\mathbb{Z}; X))} \|f\|_{L^p(S; X)}, \quad k = 1, 2, \dots$$

The infinite sum on the left-hand side effectively extends over the finite set of indices for which a_n is non-zero. Since $T_k f \rightarrow T f$ in $L^p(S, \mathcal{A})$ strongly (recalling that we replaced the original σ -algebra by the σ -algebra generated by the sets $A_j, j \geq 1$), upon passing to the limit $k \rightarrow \infty$ we obtain the desired estimate. \square

By using Proposition 10.7.8, it is possible to prove an analogue of Theorem 10.7.5 for generators of positive C_0 -contraction semigroups on $L^p(S)$. We recall from (10.46) the notation K_g for the convolution operator. Functions on \mathbb{R}_+ will be identified with function on \mathbb{R} in the natural way, i.e., by extending them by zero on the negative axis.

Theorem 10.7.9 (Coifman–Weiss, transference for positive contraction semigroups on L^p -spaces). *Let (S, \mathcal{A}, μ) be a measure space, let $1 \leq p < \infty$, and let X be a Banach space. Let $-A$ be the generator of a positive C_0 -semigroup $(T(t))_{t \geq 0}$ of contractions on $L^p(S)$, and hence on $L^p(S; X)$. Then the Phillips calculus satisfies, for all $g \in L^1(\mathbb{R}_+)$,*

$$\|\Phi_g^+(A)\|_{\mathcal{L}(L^p(S; X))} \leq \|K_g\|_{\mathcal{L}(L^p(\mathbb{R}; X))}.$$

Proof. As in the discrete case, Young’s inequality allows us to reduce the proof of the theorem to the case where g is a step function supported on finitely many dyadic intervals $[j2^{-n}, (j + 1)2^{-n})$. The idea of the proof is to also approximate the semigroup by powers of a fixed operator and then to apply the bound for the discrete case.

Consider, for $N = 1, 2, \dots$ and $j \in \mathbb{Z}$, the numbers

$$a_j^{(N)} := \frac{1}{2^N} \int_0^1 \int_0^1 g\left(\frac{j+t-s}{2^N}\right) ds dt, \tag{10.48}$$

where we think g as a function in $L^p(\mathbb{R}; X)$ by zero-extension on \mathbb{R}_- . Identifying the finite sequence $a^{(N)} = (a_j^{(N)})_{j \in \mathbb{Z}}$ with an element of $\ell^1(\mathbb{Z})$, for a finitely non-zero sequence $c = (c_j)_{j \in \mathbb{Z}}$ we have

$$(\kappa_{a^{(N)}} c)_k = \sum_{j \in \mathbb{Z}} a_{k-j}^{(N)} c_j$$

$$\begin{aligned}
&= \frac{1}{2^N} \int_0^1 \int_0^1 \sum_{j \in \mathbb{Z}} g\left(\frac{k-j+t-s}{2^N}\right) ds dt c_j \\
&= \int_k^{k+1} \sum_{j \in \mathbb{Z}} \int_j^{j+1} g^{(N)}(t-s) ds dt c_j \\
&\hspace{15em} (\text{setting } g^{(N)}(u) := 2^{-N} g(2^{-N}u)) \\
&= \int_k^{k+1} \int_{-\infty}^{\infty} g^{(N)}(t-s) C(s) ds dt \\
&\hspace{15em} (\text{setting } C := \sum_{j \in \mathbb{Z}} c_j \mathbf{1}_{(j, j+1)}) \\
&= E_k(g^{(N)} * C) \hspace{10em} (\text{setting } E_k h := \int_k^{k+1} h(u) du).
\end{aligned}$$

Let $\mathbb{E}_{\mathbb{Z}}$ denote the conditional expectation with respect to the σ -algebra generated by the intervals $[k, k+1)$. Then

$$\begin{aligned}
\|\kappa_{a^{(N)}} c\|_{\ell^p(\mathbb{Z}; X)} &= \left(\sum_{k \in \mathbb{Z}} \|E_k(g^{(N)} * C)\|_X^p \right)^{1/p} \\
&= \|\mathbb{E}_{\mathbb{Z}}(g^{(N)} * C)\|_{L^p(\mathbb{R}; X)} \leq \|g^{(N)} * C\|_{L^p(\mathbb{R}; X)} \\
&\leq \|K_{g^{(N)}}\|_{\mathcal{L}(L^p(\mathbb{R}; X))} \|C\|_{L^p(\mathbb{R}; X)} = \|K_g\|_{\mathcal{L}(L^p(\mathbb{R}; X))} \|c\|_{\ell^p(\mathbb{Z})},
\end{aligned}$$

where the last identity follows by routine changes of variables.

So far, the sequence $c = (c_j)_{j \in \mathbb{Z}}$ was finitely non-zero. Since such sequences are dense in $\ell^p(\mathbb{Z}; X)$, the above estimates prove that

$$\|\kappa_{a^{(N)}}\|_{\mathcal{L}(\ell^p(\mathbb{Z}; X))} \leq \|K_g\|_{\mathcal{L}(L^p(\mathbb{R}; X))} \quad \text{for all } N.$$

Now we are in a position to apply Proposition 10.7.8 to the operator $T := T(2^{-N})$ and obtain the estimate

$$\begin{aligned}
\left\| \sum_{j \geq 0} a_j^{(N)} T(j2^{-N}) \right\|_{\mathcal{L}(L^p(S; X))} &\leq \|\kappa_{a^{(N)}}\|_{\mathcal{L}(\ell^p(\mathbb{Z}; X))} \\
&\leq \|K_g\|_{\mathcal{L}(L^p(\mathbb{R}; X))}.
\end{aligned} \tag{10.49}$$

The final step is to realise that, in a sense to be made precise, $a_j^{(N)} \approx 2^{-N} g(j2^{-N})$ so that

$$\sum_{j \geq 0} a_j^{(N)} T(j2^{-N}) f \approx 2^{-N} \sum_{j \geq 0} g(j2^{-N}) T(j2^{-N}) f.$$

The latter is a Riemann sum for the integral $\Phi_g(A)f = \int_0^\infty g(t)T(t)f dt$.

Turning to the details, we begin by recalling the assumption, made at the beginning of the proof, that g is a dyadic step function, say supported on finitely many dyadic intervals of length 2^{-n} , where n is some given positive integer. Then for $N \geq n$ we have $g(t) = g(j2^{-N})$ whenever t belongs to a

dyadic interval of the form $[j2^{-N}, (j+1)2^{-N})$. As a result it is immediately obvious that

$$\|\Phi_g(A)f\|_{L^p(S;X)} \leq \liminf_{N \rightarrow \infty} \left\| 2^{-N} \sum_{j \geq 0} g(j2^{-N})T(j2^{-N})f \right\|_{L^p(S;X)},$$

keeping in mind that the sum on the right-hand side effectively extends over at most finitely many non-zero terms. Again since g is dyadic, for $N \geq n$ the definition (10.48) implies that $a_j^{(N)} = 2^{-N}g(j2^{-N})$ for all $0 \leq j \leq 2^N - 1$ except possibly for values of the form $j = k2^{N-n}$. Therefore

$$\begin{aligned} \liminf_{N \rightarrow \infty} \left\| \sum_{j \geq 0} a_j^{(N)}T(j2^{-N})f \right\|_{L^p(S;X)} \\ = \liminf_{N \rightarrow \infty} \left\| 2^{-N} \sum_{j \geq 0} g(j2^{-N})T(j2^{-N})f \right\|_{L^p(S;X)}, \end{aligned} \quad (10.50)$$

as the relative contribution of the exceptional j 's tends to zero as $N \rightarrow \infty$.

The proof is concluded by combining the estimates (10.49) and (10.50). \square

10.7.c Hieber–Prüss theorems on H^∞ -calculus for generators

We are now in a position to present neat corollaries of the preceding considerations in the context of H^∞ -calculus. Recalling the notion of Fourier multipliers from Section 8.3, we observe that

$$\mathcal{F}(K_g f) = \mathcal{F}(g * f) = \widehat{g}f = \mathcal{F}(T_{\widehat{g}}f), \quad (10.51)$$

so that K_g coincides with the Fourier multiplier $T_{\widehat{g}}$.

Theorem 10.7.10 (Hieber–Prüss I). *Let iA be the generator of a uniformly bounded C_0 -group $(U(t))_{t \in \mathbb{R}}$ on a UMD space X . Then A has a bounded bisectorial H^∞ -calculus of angle 0.*

Proof. Recall from Example 10.6.3 that if iA is the generator of a uniformly bounded C_0 -group, then A is bisectorial of angle 0.

By Proposition 10.7.2 and Theorem 10.7.5, we have

$$\|f(A)\|_{\mathcal{L}(X)} = \|\Phi_{g_f}(A)x\|_{\mathcal{L}(X)} \leq \|K_{g_f}\|_{\mathcal{L}(L^p(\mathbb{R};X))} \|U\|_\infty^2.$$

With observation (10.51), the Mihlin multiplier theorem (Corollary 8.3.11) and Lemma 10.7.4, we obtain

$$\begin{aligned} \|K_{g_f}\|_{\mathcal{L}(L^p(\mathbb{R};X))} &= \|T_{\widehat{g}_f}\|_{\mathcal{L}(L^p(\mathbb{R};X))} \\ &\leq 200\beta_{p,X}^2 \widehat{h}_{p,X} \sup_{\xi \in \mathbb{R} \setminus \{0\}} \max\{|\widehat{g}_f(\xi)|, |\xi \widehat{g}_f'(\xi)|\} \\ &\leq 200\|U\|_\infty^2 \beta_{p,X}^2 \widehat{h}_{p,X} \frac{1}{\sin \sigma} \|f\|_{H^\infty(\Sigma_\sigma^{\text{bi}})}. \end{aligned}$$

This proves that A has a bounded bisectorial $H^\infty(\Sigma_\sigma^{\text{bi}})$ -calculus. Since the choice of $0 < \sigma < \frac{1}{2}\pi$ was arbitrary, the theorem is proved. \square

Corollary 10.7.11. *Let iA generate a bounded C_0 -group on a UMD Banach space X . If A is R -bisectorial, then A^2 is R -sectorial and has a bounded H^∞ -calculus of angle 0.*

Proof. Combine the previous theorem with Theorem 10.6.7. □

Theorem 10.7.12 (Hieber–Prüss II). *Let (S, \mathcal{A}, μ) be a measure space, $1 < p < \infty$, and X be a UMD space. Let $-A$ be the generator of a positive C_0 -contraction semigroup $(S(t))_{t \geq 0}$ on $L^p(S)$, and thus on $L^p(S; X)$. Then A has a bounded H^∞ -calculus on $L^p(S; X)$ of angle $\omega_{H^\infty}(A) \leq \frac{1}{2}\pi$.*

Proof. By Proposition 10.7.2 and Theorem 10.7.9, for functions $f \in H^1(\Sigma_\sigma)$ with $\frac{1}{2}\pi < \sigma < \pi$ we obtain

$$\|f(A)\|_{\mathcal{L}(X)} = \|\Phi_{g_f^+}^+(A)\|_{\mathcal{L}(X)} \leq \|K_{g_f^+}\|_{L^p(\mathbb{R}; X)},$$

where $K_{g_f^+}$ denotes convolution with g_f^+ .

By observation (10.51), the Mihlin multiplier theorem (Corollary 8.3.11) and Lemma 10.7.4, we obtain

$$\begin{aligned} \|K_{g_f^+}\|_{\mathcal{L}(L^p(\mathbb{R}; X))} &= \|T_{\widehat{g}_f^+}\|_{\mathcal{L}(L^p(\mathbb{R}; X))} \\ &\leq 200\beta_{p,X}^2 \widehat{h}_{p,X} \sup_{\xi \in \mathbb{R} \setminus \{0\}} \max\{|\widehat{g}_f^+(\xi)|, |\xi(\widehat{g}_f^+)'(\xi)|\} \\ &\leq 200\|U\|_\infty^2 \beta_{p,X}^2 \widehat{h}_{p,X} \frac{1}{\cos \sigma} \|f\|_{H^\infty(\Sigma_\sigma)}. \end{aligned}$$

□

10.7.d Analytic semigroups of positive contractions on L^p

In Theorem 10.7.12 we have seen that if $-A$ generates a positive C_0 -contraction semigroup $(S(t))_{t \geq 0}$ on a space $L^p(S)$ with $1 < p < \infty$, then A admits a bounded H^∞ -calculus and $\omega_{H^\infty}(A) \leq \frac{1}{2}\pi$. The following theorem shows that under stronger assumptions one obtains $\omega_{H^\infty}(A) < \frac{1}{2}\pi$. Unlike Theorem 10.7.12, the one that follows is restricted to the scalar-valued case.

Theorem 10.7.13. *Let $-A$ be the generator of a positive C_0 -contraction semigroup $(S(t))_{t \geq 0}$ on a space $L^p(S)$, where (S, \mathcal{A}, μ) is a measure space and $1 < p < \infty$. If $(S(t))_{t \geq 0}$ extends to a bounded analytic C_0 -contraction semigroup on the sector Σ_η for some $0 < \eta < \frac{1}{2}\pi$, then A is R -sectorial, admits a bounded H^∞ -calculus, and we have*

$$\omega_R(A) = \omega_{H^\infty}(A) \leq \frac{1}{2}\pi - \frac{1}{2}\eta(p \wedge p').$$

To prepare for the proof, we begin by preparing some lemmas for bounded analytic operator-valued functions $z \mapsto N(z)$ defined on a sector. Eventually we shall apply these results to the analytic extension of the function N given by

$$N(t)f := \frac{1}{t} \int_0^t S(s)f \, ds, \quad f \in L^p(S).$$

Our main tool for estimating N will be the following semigroup version of Akcoglu’s maximal ergodic theorem:

Theorem 10.7.14 (Akcoglu’s maximal ergodic theorem). *If the C_0 -semigroup $(S(t))_{t \geq 0}$ is positive and contractive on $L^p(S)$, with $1 < p < \infty$, then for all $f \in L^p(S)$ we have*

$$\left\| \sup_{t > 0} \left| \frac{1}{t} \int_0^t S(s)f \, ds \right| \right\|_p \leq p' \|f\|_p.$$

Proof. The main step is to prove that for all choices of finitely many dyadic $t_1, \dots, t_k > 0$ and for all $f \in L^p(S)$ we have

$$\left\| \sup_{1 \leq j \leq k} \left| \frac{1}{t_j} \int_0^{t_j} S(s)f \, ds \right| \right\|_p \leq p' \|f\|_p.$$

Once we have this, the general case follows by considering an enumeration of the positive dyadic numbers, say $(q_n)_{n \geq 1}$, applying the above with $t_j = q_j$ for $j = 1, \dots, k$, and passing to the limit $k \rightarrow \infty$. This will give the result with ‘ $t > 0$ ’ replaced by ‘ $t > 0$ and dyadic’; as a last step we can extend to supremum to all $t > 0$ by the following limiting argument. From

$$\left\| \int_0^t S(s)f \, ds \right\|_p \leq \int_0^t \|S(s)f\|_p \, ds$$

and the boundedness of the semigroup it immediate that $s \mapsto (S(s)f)(x)$ is locally integrable at almost every $x \in S$, and then $t \mapsto \frac{1}{t} \int_0^t S(s)f(x) \, ds$ is continuous at the same values of x . From this the approximation by dyadic values is immediate.

Let us now fix dyadic numbers $t_1, \dots, t_k > 0$. Fix an arbitrary $\varepsilon > 0$ and choose the integer $N \geq 0$ so large that

$$\|S(t)f - f\| < \varepsilon \text{ for all } t \in [0, 2^{-N}]. \tag{10.52}$$

We may assume that the numbers t_j are pairwise different dyadic numbers and have the form $t_j = m_j 2^{-n}$ with $n \geq N$. It then suffices to prove the estimate

$$\left\| \sup_{1 \leq i \leq M} \left| \frac{1}{i 2^{-n}} \int_0^{i 2^{-n}} S(s)f \, ds \right| \right\|_p \leq \|f\|_p.$$

Upon replacing f by $|f|$, there is no loss of generality if we assume $f \geq 0$. We have, for $n \geq N$,

$$\begin{aligned} & \left\| \sup_{1 \leq i \leq M} \frac{1}{i2^{-n}} \int_0^{i2^{-n}} S(s)f \, ds \right\|_p \\ &= \left\| \sup_{1 \leq i \leq M} \frac{1}{i2^{-n}} \sum_{\ell=0}^{i-1} \int_{\ell2^{-n}}^{(\ell+1)2^{-n}} S(s)f \, ds \right\|_p \\ &= \left\| \sup_{1 \leq i \leq M} \frac{1}{i} \sum_{\ell=0}^{i-1} S(\ell2^{-n})\tilde{S}_{2^{-n}}f \right\|_p \quad (\text{with } \tilde{S}_{2^{-n}}f := \frac{1}{2^{-n}} \int_0^{2^{-n}} S(s)f \, ds) \\ &\leq p' \|\tilde{S}_{2^{-n}}f\|_p \leq p'(\|f\|_p + \varepsilon), \end{aligned}$$

where the first estimate was an application of Akcoglu’s maximal ergodic theorem in its discrete form given in Theorem I.2.1, and the last step used (10.52). Since $\varepsilon > 0$ was arbitrary, this completes the proof. \square

Corollary 10.7.15. *If the C_0 -semigroup $(S(t))_{t \geq 0}$ is positive and contractive on $L^p(S)$, with $1 < p < \infty$, then for all $t > 0$ and $f_1, \dots, f_k \in L^p(S)$ we have*

$$\left\| \sup_{1 \leq j \leq k} \sup_{t > 0} \left| \frac{1}{t} \int_0^t S(s)f_j \, ds \right| \right\|_p \leq p' \left\| \sup_{1 \leq j \leq k} |f_j| \right\|_p.$$

Proof. Apply the theorem with $f := \sup_{1 \leq j \leq k} |f_j|$. \square

Lemma 10.7.16. *Let $p \in [1, 2]$ and suppose that $N : \overline{\Sigma_\delta} \rightarrow \mathcal{L}(L^p(S))$ is a strongly continuous and uniformly bounded function, which is holomorphic on Σ_δ . If there is a constant $C \geq 0$ such that, for all choices of finitely many $t_1, \dots, t_k \in \mathbb{R}_+$ and $f_1, \dots, f_k \in L^p(S)$,*

$$\left\| \sup_{1 \leq j \leq k} |N(t_j)f_j| \right\|_p \leq C \left\| \sup_{1 \leq j \leq k} |f_j| \right\|_p, \tag{10.53}$$

then the family $\mathcal{F} = \{N(z) : z \in \Sigma_{\delta p/2}\}$ is R -bounded and

$$\mathcal{R}(\mathcal{F}) \leq \kappa_{2,p}^2 C^{1-p/2} \sup_{t > 0} \|N(t)\|_p^{p/2}.$$

Proof. For $p = 2$ this is clear. We may therefore assume that $p \in [1, 2)$.

The boundedness of $N(z)$ on $\overline{\Sigma_\delta}$ implies that for z_1, \dots, z_k with $|\arg z_j| = \delta$ and $f_1, \dots, f_k \in L^p(S)$ we have

$$\begin{aligned} & \left\| \left(\sum_{j=1}^k |N(z_j)f_j|^p \right)^{1/p} \right\|_p^p = \sum_{j=1}^k \|N(z_j)f_j\|_p^p \\ & \leq K^p \sum_{j=1}^k \|f_j\|_p^p = K^p \left\| \left(\sum_{j=1}^k |f_j|^p \right)^{1/p} \right\|_p^p, \end{aligned} \tag{10.54}$$

where $K := \sup_{z \in \overline{\Sigma_\delta}} \|N(z)\|$. On the other hand, to prove the lemma it suffices to show the following square function estimate: for all z_1, \dots, z_k with $|\arg z_j| = \delta p/2$ and $f_1, \dots, f_k \in L^p(S)$,

$$\left\| \left(\sum_{j=1}^k |N(z_j) f_j|^2 \right)^{1/2} \right\|_p \leq C^{1-p/2} K^{p/2} \left\| \left(\sum_{j=1}^k |f_j|^2 \right)^{1/2} \right\|_p. \tag{10.55}$$

Indeed, up to a multiplicative constant $\kappa_{2,p} \kappa_{p,2} = \kappa_{2,p}$ in both directions, by Proposition 6.3.3 the square functions on both sides of (10.55) are equivalent to Rademacher sums, and interpreted in this way the inequality asserts the R -boundedness of the family $\{N(z) : |\arg z| = \delta p/2\}$ with R -bound at most $\kappa_{2,p}^2 C$. Then $\{N(z) : |\arg z| \leq \delta p/2\}$ is R -bounded, with the same R -bound, by Proposition 8.5.8.

We shall obtain the estimate (10.55) (which can be interpreted as ℓ^2 -boundedness of the operators $N(t)$) by interpolating the inequalities (10.53) and (10.54) (which can be interpreted as ℓ^∞ -boundedness and ℓ^p -boundedness of these operators). To make this precise we fix $t_1, \dots, t_k \in \mathbb{R}_+$ and define a strongly continuous mapping $M : \overline{\Sigma_\delta} \rightarrow \mathcal{L}(L^p(S, \ell_k^p))$ by

$$M(z)(f_1, \dots, f_k) = (N(t_1 z) f_1, \dots, N(t_k z) f_k).$$

This mapping is holomorphic on Σ_δ . Now (10.53) says that

$$\|M(z)\|_{\mathcal{L}(L^p(S, \ell_k^\infty))} \leq C \text{ for } \arg z = 0$$

and (10.54) says that

$$\|M(z)\|_{\mathcal{L}(L^p(S, \ell_k^p))} \leq K \text{ for } |\arg z| = \delta.$$

Since $\frac{1}{2} = \frac{\theta}{p} + \frac{1-\theta}{\infty}$ for $\theta = \frac{p}{2}$, the interpolation lemma 10.7.17 below (with $\sigma_0 = 0$, $\sigma_1 = \delta$, $p_0 = p_1 = p$, $q_0 = \infty$, $q_1 = 2$, and $\theta = p/2$) gives

$$\|M(z)\|_{\mathcal{L}(L^p(S, \ell_k^2))} \leq C^{1-p/2} K^{p/2} \text{ for } |\arg z| = \delta p/2,$$

which in turn implies (10.55) for $z_j = t_j e^{\pm i \delta p/2}$. □

In the next lemma we use the notation $\Sigma_{\sigma_0, \sigma_1} = \{z \in \mathbb{C} : \sigma_0 < \arg z < \sigma_1\}$.

Lemma 10.7.17. *Let $\leq p_0, p_1, q_0, q_1 \leq \infty$ and fix an integer $k \geq 1$. Consider a family of operators*

$$N(z) : L^{p_0}(S, \ell_k^{q_0}) \cap L^{p_1}(S, \ell_k^{q_1}) \rightarrow L^{p_0}(S, \ell_k^{q_0}) + L^{p_1}(S, \ell_k^{q_1})$$

satisfying the following conditions:

- as an $L^{p_0}(S; \ell_k^{q_0}) + L^{p_1}(S; \ell_k^{q_1})$ -valued function, $z \rightarrow N(z)F$ is continuous on $\overline{\Sigma_{\sigma_0, \sigma_1}}$ and holomorphic on $\Sigma_{\sigma_0, \sigma_1}$ for all $F \in L^{p_0}(S; \ell_k^{q_0}) \cap L^{p_1}(S; \ell_k^{q_1})$;

- the boundary functions $r \mapsto N(re^{i\sigma_j})F$ are continuous $L^{p_j}(S; \ell_k^{q_j})$ -valued functions for all $F \in L^{p_j}(S; \ell_k^{q_j})$ and

$$\|N(z)\|_{\mathcal{L}(L^{p_j}(S; \ell_k^{q_j}))} \leq L_j \quad \text{for } \arg z = \sigma_j \quad (j = 0, 1). \quad (10.56)$$

For $\theta \in (0, 1)$ put

$$\frac{1}{p} = \frac{1-\theta}{p_0} + \frac{\theta}{p_1}, \quad \frac{1}{q} = \frac{1-\theta}{q_0} + \frac{\theta}{q_1}, \quad \sigma = (1-\theta)\sigma_0 + \theta\sigma_1.$$

Then $N(z)$ maps $L^p(S; \ell_k^q)$ into itself for all $\arg(z) = \sigma$ and

$$\|N(z)\|_{\mathcal{L}(L^p(S; \ell_k^q))} \leq K_0^{1-\theta} K_1^\theta \quad \text{for } \arg(z) = \sigma.$$

Proof. Let $\mathbb{S} = \{z : 0 < \Re z < 1\}$ denote the unit strip and put

$$M(\zeta) := N(\exp[i(\sigma_0 + (\sigma_1 - \sigma_0)\zeta)]), \quad \zeta \in \mathbb{S}.$$

Then, by (10.56),

$$\|M(\zeta)\|_{\mathcal{L}(L^{p_j}(S; \ell_k^{q_j}))} \leq L_j \quad \text{for } \Re \zeta = j \quad (j = 0, 1).$$

By Theorem 2.2.6, for the complex interpolation method we have an isometric isomorphism

$$L^p(S, \ell_k^q) = [L^{p_0}(S, \ell_k^{q_0}), L^{p_1}(S, \ell_k^{q_1})]_\theta.$$

For $F \in L^p(S, \ell_k^q)$ with $\|F\| < 1$, by the definition of the complex method there is a continuous function $f : \overline{\mathbb{S}} \rightarrow L^{p_0}(S; \ell_k^{q_0}) + L^{p_1}(S; \ell_k^{q_1})$, holomorphic on \mathbb{S} , with $f(\theta) = F$ and

$$\|f(\zeta)\|_{L^{p_j}(S; \ell_k^{q_j})} \leq 1 \quad \text{for } \Re \zeta = j \quad (j = 0, 1).$$

For $z \in \Sigma_{\sigma_0, \sigma_1}$ let $\zeta(z) \in \mathbb{S}$ be the unique point such that $\exp[i(\sigma_0 + (\sigma_1 - \sigma_0)\zeta(z))] = z$.

Then for $z \in \Sigma_{\sigma_0, \sigma_1}$ with $\arg(z) = \sigma$, say $z = re^{i\sigma}$, we have $N(re^{i\sigma})F = M(\theta + i \log r)f(\theta)$. This suggests to consider the function

$$\psi(\zeta) := M(\zeta + i \log r)f(\zeta), \quad \text{for } \zeta \in \overline{\mathbb{S}}.$$

As a function with values in $L^{p_0}(S; \ell_k^{q_0}) + L^{p_1}(S; \ell_k^{q_1})$, this function is continuous on $\overline{\mathbb{S}}$ and holomorphic on \mathbb{S} , it satisfies $\|\psi(z)\|_{L^{p_j}(S; \ell_k^{q_j})} \leq L_j \quad (j = 0, 1)$, and we have $\psi(\theta) = N(re^{i\sigma})F$. Again by the definition of the complex method this implies $N(re^{i\sigma})F \in [L^{p_0}(S, \ell_k^{q_0}), L^{p_1}(S, \ell_k^{q_1})]_\theta = L^p(S, \ell_k^q)$ and

$$\|N(re^{i\sigma})F\|_{L^p(S; \ell_k^q)} \leq L_0^{1-\theta} L_1^\theta.$$

Since $F \in L^p(S; \ell_k^q)$ with $\|F\| < 1$ was arbitrary, this proves the lemma. \square

Lemma 10.7.18. *Let X and Y be Banach spaces and let $0 < \nu < \sigma < \vartheta < \pi$. Let $N : \Sigma_\vartheta \rightarrow \mathcal{L}(X, Y)$ be a bounded holomorphic function and suppose that the set $\{N(z) : z \in \partial\Sigma_\sigma, z \neq 0\}$ is R -bounded. Then*

$$\left\{ z \frac{d}{dz} N(z) : z \in \Sigma_\nu \right\}$$

is R -bounded.

Proof. By Theorem 8.5.2, this follows from Cauchy’s formula

$$z \frac{d}{dz} N(z) = \int_{\partial\Sigma_\sigma} h_z(\zeta) N(\zeta) d\zeta, \quad z \in \Sigma_\nu,$$

with $h_z(\zeta) = \frac{1}{2\pi i} z(\zeta - z)^{-2}$, noting that $\sup\{\|h_z\|_1 : z \in \partial\Sigma_\nu\} < \infty$. □

We are now ready to prove Theorem 10.7.13.

Proof of Theorem 10.7.13. First let $p \in (1, 2]$, and assume that the semigroup $(S(t))_{t \geq 0}$ extends analytically to a bounded semigroup $(S(z))_{z \in \Sigma_\eta}$ for some $0 < \eta < \frac{1}{2}\pi$. Then we may also extend $N(t) = \frac{1}{t} \int_0^t S(s) ds$ holomorphically to Σ_η by

$$N(z)f = \frac{1}{z} \int_{\Gamma_{0,z}} S(\mu) f d\mu, \quad z \in \Sigma_\eta,$$

where $\Gamma_{0,z}$ is the line segment connecting 0 and z . Fix $0 < \delta < \eta$ and observe that the maximal ergodic estimate of Corollary 10.7.15, namely

$$\left\| \sup_{1 \leq j \leq k} |N(t_j) f_j| \right\|_p \leq p' \left\| \sup_{1 \leq j \leq k} |f_j| \right\|_p,$$

implies (10.53) for the holomorphic function $N(z)$, with constant $C = p'$. By Lemma 10.7.16 we conclude that for $\delta' = \delta p/2$ the set $\{N(z) : z \in \Sigma_{\delta'}\}$ is R -bounded. Also, fixing any $0 < \delta'' < \delta'$, Lemma 10.7.18 implies the R -boundedness of $\{z \frac{d}{dz} N(z) : z \in \Sigma_{\delta''}\}$. Since $S(z) = N(z) + z \frac{d}{dz} N(z)$, it follows that the set $\{S(z) : z \in \Sigma_{\delta''}\}$ is R -bounded.

If $p \in (2, \infty)$, by what we just proved the adjoint family $\{S^*(z) : z \in \Sigma_{\delta''}\}$, which is a bounded analytic C_0 -semigroup on $L^{p'}(S)$, is R -bounded on $L^{p'}(S)$. By Proposition 8.4.1 (which can be applied because $L^p(S)$ is K -convex), the family $\{S(z) : z \in \Sigma_{\delta''}\}$ is R -bounded.

An appeal to Proposition 10.3.3 now shows that A is R -sectorial of angle $\omega_R(A) \leq \frac{1}{2}\pi - \delta''$. This was the heart of the matter: now that we have secured R -sectoriality we may apply Proposition 10.4.10 to conclude that $\omega_{H^\infty}(A) = \omega_R(A) \leq \frac{1}{2}\pi - \delta''$ (the proposition can be applied since we already know, by virtue of Theorem 10.7.12, that A has a bounded H^∞ -calculus (of angle $\leq \frac{1}{2}\pi$)).

Tracing the optimal values of the various angles provided by the above proof, we find the explicit bound

$$\omega_{H^\infty}(A) \leq \frac{1}{2}\pi - \frac{1}{2}\eta(p \wedge p').$$

This completes the proof of the theorem. \square

10.8 Notes

The H^∞ -calculus for sectorial operators on Hilbert spaces was developed by [McIntosh \[1986\]](#) as a tool in his pursuit of the Kato square root problem. His work introduced harmonic analysis ideas motivated by Littlewood–Paley theory and classical g -functions into abstract operator theory and combined them with spectral theoretic techniques such as bounded imaginary powers and semigroup theory. For the extension to Banach spaces, in particular L^p -spaces, the central paper is by [Cowling, Doust, McIntosh, and Yagi \[1996\]](#).

A full treatment of the H^∞ -calculus could easily cover a volume in itself. In order to keep the presentation within reasonable bounds we chose to present in this volume the construction of the H^∞ -calculus and its characterisation through square function estimates, along with a discussion of those examples that can be treated in a self-contained way with tools from functional analysis and harmonic analysis presently at our disposal. Further topics related to the H^∞ -calculus, such as fractional powers, bounded imaginary powers, sums of operators, and perturbation theory, as well as their applications in the theory of deterministic and stochastic evolution equations, will be treated in the next volume.

Section 10.1

The material of this section is classical and can be found in, e.g., [Denk, Hieber, and Prüss \[2003\]](#), [Kato \[1995\]](#), [Komatsu \[1966\]](#), [Kunstmann and Weis \[2004\]](#). The notion of sectoriality goes back to the work of Kato (in connection with form methods), Balakrishnan, Komatsu and others in the 1960s.

Section 10.2

The Dunford functional calculus for bounded operators is classical and can be found in many functional analysis textbooks. Surveys of the theory of H^∞ -calculus include the monograph [Haase \[2006\]](#), the lecture notes [Denk, Hieber, and Prüss \[2003\]](#), [Kunstmann and Weis \[2004\]](#), and the survey papers [Weis \[2006\]](#) and [Batty \[2009\]](#).

The uniform boundedness in Calderón reproducing formula, Proposition [10.2.5](#), is essentially from [McIntosh \[1986\]](#); our proof uses an idea of [Haase \[2006, Proposition 5.2.4\]](#). The version for functions f with $f(z) \log(z)$ in $H^1(\Sigma)$ may be new.

Early examples of sectorial operators without a bounded H^∞ -calculus were given in [McIntosh and Yagi \[1990\]](#). The idea of using conditional bases for this

goes back to [Baillon and Clément \[1991\]](#), [Venni \[1993\]](#), [Lancien \[1998\]](#). For the existence of such bases in every Banach space with a Schauder basis see [Pelczyński and Singer \[1964/1965\]](#) and the exposition in [Albiac and Kalton \[2006, Section 9.5\]](#).

The connection between UMD and the bounded H^∞ -calculus of the Laplacian Δ on $L^p(\mathbb{R}^d; X)$ and the bisectorial operator $-id/dx$ on $L^p(\mathbb{R}; X)$ was pointed out in [Hieber and Prüss \[1998\]](#).

Theorem [10.2.24](#) is stated in between the lines in [McIntosh \[1986\]](#), where also the contributions [Yagi \[1984\]](#) are credited. The direct proof presented here is due to E. Franks and appears in [Albrecht, Duong, and McIntosh \[1996\]](#). An extension of the theorem to the Banach space setting was obtained in [Kriegler and Weis \[2010\]](#), where a characterisation of the contractivity of the H^∞ -calculus, i.e., the validity of the inequality $\|f(A)\| \leq \|f\|_\infty$, is given in terms of Blaschke products.

Section 10.3

The notion of R -sectoriality was introduced in [Clément and Prüss \[2001\]](#) and [Weis \[2001a\]](#). The characterisation of R -sectoriality of Proposition [10.3.3](#) is due to [Weis \[2001b\]](#). Theorem [10.3.4](#) was proved in [Kalton and Weis \[2001\]](#). In particular this paper contains the result that the boundedness of the H^∞ -calculus implies R -sectoriality for spaces with the triangular contraction property. Another result in this direction, due to [Clément and Prüss \[2001\]](#), states that a sectorial operator with bounded imaginary powers on a UMD space is R -sectorial.

The connection between unconditional decompositions and H^∞ -calculi explained in Lemma [10.3.8](#) is one of the main themes in [Kalton and Weis \[2001\]](#). Lemma [10.3.13](#) appears in [Franks \[1997\]](#). It extends to the operator-valued H^∞ -calculus (an extension of the H^∞ -calculus to be treated in the next volume) and in this form it appears in [Kalton and Weis \[2001\]](#) and [Kalton and Weis \[2016\]](#). Corollary [10.3.15](#) appears in [Franks \[1997\]](#). Extensions and related results can be found in [Boyadzhiev and deLaubenfels \[1992\]](#), [Cowling, Doust, McIntosh, and Yagi \[1996\]](#), [Kalton and Weis \[2001\]](#).

Permanence of R -sectoriality under real and complex interpolation was proved in [Kaip and Saal \[2012\]](#). By using Proposition [8.4.4](#) one can show that consistent R -sectorial operators A_0 and A_1 on an interpolation couple of K -convex Banach spaces interpolate, under both the complex and the real method, to R -sectorial operators with an interpolated angle of R -sectoriality $\omega_R(A_\theta) = (1 - \theta)\omega_R(A_0) + \theta\omega_R(A_1)$.

Section 10.4

We refer the reader to [Stein \[1970b\]](#) for an in-depth discussion of the classical square functions arising in harmonic analysis. [McIntosh \[1986\]](#) and [Yagi \[1984\]](#)

introduced them as a tool in operator theory and considered square functions of the form

$$\|x\|_{\phi, A}^2 = \int_0^\infty \|\phi(tA)x\|^2 \frac{dt}{t}$$

for $\phi \in H_0^\infty(\Sigma)$, the space of bounded holomorphic functions on Σ having polynomial decay near zero and at infinity. This work was subsequently generalised to Banach spaces, first by Cowling, Doust, McIntosh, and Yagi [1996] and subsequently Le Merdy [2004], Kalton and Weis [2016]. See also the survey Le Merdy [2007].

Most of the results of Section 10.4.a are due to Kalton and Weis [2001], Kunstmann and Weis [2004] and Kalton, Kunstmann, and Weis [2006]. Proposition 10.4.6 is the discrete analogue of Proposition 10.4.17, which was proved by Le Merdy [2003, Theorem 1.1] in L^p -spaces and at the same time for Banach spaces by Kalton and Weis [2016, Proposition 7.7] in the form stated here.

The continuous square function results for general Banach spaces of Section 10.4.b are due to Kalton and Weis [2016]. For Hilbert spaces they imply Theorem 10.4.21, which is due to McIntosh [1986] and for L^p -spaces they imply Theorem 10.4.23. For formulation of Theorem 10.4.23 as presented here is from Le Merdy [2004]; a version without any R -sectoriality condition on A is in Cowling, Doust, McIntosh, and Yagi [1996], but there only certain specific functions ϕ are allowed in the implication (2) \Rightarrow (1) (square function estimates imply H^∞ -calculus).

Lemma 10.4.18 is a variation of Kalton, Kunstmann, and Weis [2006, Lemma 4.7]. Proposition 10.4.15, on the equivalences between discrete and continuous square functions, provides an effective way to go back and forth between the discrete and the more difficult continuous time case. The domination of dual square function by discrete square functions of Proposition 10.4.15(3) seems to be new.

For general Banach spaces, strict inequality $\omega(A) < \omega_{H^\infty}(A)$ may hold. A first example without dense range was given in Cowling, Doust, McIntosh, and Yagi [1996]. Subsequently in Kalton [2003] an example was constructed on a uniformly convex space, and in Kalton and Weis [preprint] on a closed subspace of L^p with $p \in (1, 2)$. It is still an open problem whether such an example can exist on an L^p -space with $1 < p < \infty$, $p \neq 2$.

The equality $\omega_{H^\infty}(A) = \omega_R(A)$ for Banach spaces with the triangular contraction property, due to Kalton and Weis [2001], is a reasonable extension of the Hilbert space result $\omega_{H^\infty}(A) = \omega(A)$. Theorem 10.4.22 is due to Le Merdy [1996, 1998] and (for invertible A) Grabowski and Callier [1996].

To avoid assumptions on the Banach space X , Kalton, Kunstmann, and Weis [2006] coined the notion of *almost R -sectoriality*. We briefly indicate how one can weaken the assumptions in some of the results of Section 10.4 by using this notion. By definition, a sectorial operator A has this property if the set

$$\{\lambda AR(\lambda, A)^2 : |\arg \lambda| > \omega\}$$

is R -bounded for some $\omega \in (\omega(A), \pi)$. R -sectoriality implies almost R -sectoriality, but the converse is false by [Kalton and Weis \[preprint\]](#). Let us denote the abscissa of almost R -sectoriality by $\tilde{\omega}_R(A)$. With the help of [Theorem 8.5.4](#) it is shown that every sectorial operator with a bounded H^∞ -calculus on a Banach space X is almost R -sectorial, and the equality $\omega_{H^\infty}(A) = \tilde{\omega}_R(A)$ holds. More generally, every sectorial operator with bounded imaginary powers is almost R -sectorial (but not necessarily R -sectorial). The following useful property of almost R -sectorial operators (which is more general than [Theorem 10.3.4\(1\)](#)) is also shown: the set $\{\varphi(tA) : t > 0\}$ is R -bounded for all $\varphi \in H^1(\Sigma_\sigma)$ with $\tilde{\omega}_R(A) < \sigma < \pi$.

[Theorem 10.4.25](#) is essentially due to [Le Merdy \[2014\]](#), who treated only the case of finite-dimensional Hilbert spaces and formulated the result in a somewhat different but equivalent form. The present formulation is from [Haak and Haase \[2013\]](#), which systematically develops the ℓ^1 -summability provided the Franks–McIntosh [Theorem H.3.1](#) used in the proof.

[Theorem 10.4.28](#) is due to [Le Merdy \[2012\]](#). The use of the specific square function corresponding to $\phi(z) = z^{1/2} \exp(-z)$ leads to a characterisation of the H^∞ -calculus with a sharper angle than is obtained by the characterisation in [Cowling, Doust, McIntosh, and Yagi \[1996\]](#). Note that no R -sectoriality assumption is made in the statement of [Theorem 10.4.28](#). In [Le Merdy \[2012\]](#), the result is presented only in an L^p -setting, but the possibility to extend it to Banach spaces with Pisier’s contraction property was already pointed out in the paper. For sectorial operators on a Hilbert spaces, the theorem reduces to a result of [McIntosh \[1986\]](#). A discrete version of the theorem can be found in [Le Merdy \[2014\]](#).

Ritt operators

We have treated both continuous square functions and their discrete analogues, and in fact we used the former as a basis for discussing the latter. In a different direction, it is possible to ‘discretise’ the H^∞ -calculus on the operator level. A *Ritt operator* is a bounded operator T acting on a Banach space X which is *power bounded*, i.e., $\sup_{n \in \mathbb{N}} \|T^n\| < \infty$, and satisfies

$$\sup_{n \geq 1} n \|T^n - T^{n-1}\| < \infty.$$

Ritt operators take the role of sectorial operators for the discrete-time problem

$$\begin{cases} u_{n+1} &= Tu_n + f_n, & n \in \mathbb{Z}, \\ u_0 &= 0. \end{cases}$$

Early studies include [Blunck \[2001\]](#), [Kalton and Portal \[2008\]](#), [Portal \[2003\]](#). Subsequently, the H^∞ -calculus for Ritt operators has been developed by [Kalton and Portal \[2008\]](#), [Le Merdy \[2014\]](#), [Lancien and Le Merdy \[2015\]](#), [Arhancet and Le Merdy \[2014\]](#), [Arhancet, Fackler, and Le Merdy \[2017\]](#). It

was shown in [Le Merdy \[2014\]](#) a Ritt operator T on a space L^p with $1 < p < \infty$ admits a bounded H^∞ -calculus if and only if the square functions estimate

$$\left\| \left(\sum_{n \geq 1} n \|T^n f - T^{n-1} f\|^2 \right)^{1/2} \right\|_{L^p} \approx \|f\|_{L^p}$$

holds. This result was extended to Ritt operators on general Banach spaces by [Schwenninger \[2016b\]](#). In such results, the role of sectors is taken by Stolz domains. By definition, the *Stolz domain* of angle $\omega \in (0, \frac{1}{2}\pi)$ is the interior \mathbb{B}_ω of the convex hull of the point 1 and the disc $B(0, \sin \omega)$. A bounded operator $T \in \mathcal{L}(X)$ is a Ritt operator if and only if there exists an $\omega \in (0, \frac{1}{2}\pi)$ such that $\sigma(T) \subset \overline{\mathbb{B}_\omega}$ and

$$\sup_{\lambda \in \mathbb{C} \setminus \overline{\mathbb{B}_\omega}} \|(\lambda - 1)R(\lambda, T)\| < \infty,$$

and in this case $I - T$ is ω -sectorial; see [Lyubich \[1999\]](#), [Nagy and Zemánek \[1999\]](#) and the discussion in [Le Merdy \[2014\]](#).

Conical square functions

Besides the square functions functions that we have considered in this treatment, square function norms of the form

$$\left(\int_{\mathbb{R}^n} \left(\iint_{|y-x| < t} |F(y, t)|^2 \frac{dy dt}{t^{n+1}} \right)^{p/2} dx \right)^{1/p}, \tag{10.57}$$

where frequently $F(y, t) = (\psi(tA)f)(y)$, play an important role in the theory of H^∞ -calculus. The object in (10.57) is often called a *conical square function* (norm), due to the cone-like shape of the integration domain $\{(y, t) \in \mathbb{R}^n \times (0, \infty) : |y - x| < t\}$. The square functions of the type we have considered, where the quadratic integral extends over $t \in (0, \infty)$ only, are sometimes called *vertical square functions*, in order to make the distinction. In classical harmonic analysis, one can also find several “non-tangential” square functions, like the g_λ^* function of [Stein \[1970a, Section IV.2\]](#), where the quadratic integral extends over all $(y, t) \in \mathbb{R}^d \times (0, \infty)$ but involves a decaying factor as (y, t) gets further away from the cone, but this direction would take us too far afield.

In the context of functional calculus, conical square functions as in (10.57) are particularly useful when dealing with operators without reasonable kernel bounds, such as the elliptic operators of the form $-\operatorname{div}B\nabla$ studied in the Kato square root problem (see also the Notes to Section 10.6). In general such operators are not sectorial on $L^p(\mathbb{R}^d)$ for all $1 < p < \infty$ (see [Auscher \[2007\]](#) for more on this). A sample of the rapidly growing literature on this subject is [Auscher, Kriegler, Monniaux, and Portal \[2012b\]](#), [Auscher, McIntosh, and Russ \[2007\]](#), [Auscher, Monniaux, and Portal \[2012c, 2015\]](#), [Hofmann and Mayboroda \[2009\]](#), [Frey, McIntosh, and Portal \[2014\]](#). A comparison of square

functions with the classical ‘vertical’ square functions is made in [Auscher, Hofmann, and Martell \[2012a\]](#).

Conical square functions are closely related to the class of so-called *tent spaces* $T^{p,q}$ introduced by [Coifman, Meyer, and Stein \[1985\]](#). The space $T^{p,2}$ with $q = 2$ has the closest relation to square functions. [Harboure, Torrea, and Viviani \[1991\]](#) showed that these spaces can be isomorphically embedded as complemented subspaces of a suitable L^p -space of L^q -valued functions. This fact was used in [Hytönen, Van Neerven, and Portal \[2008b\]](#) to introduce the vector-valued tent space $T^{p,2}(X)$ for UMD spaces X and to show that certain singular integral operators are boundedness from $L^p(X)$ to $T^{p,2}(X)$.

Section 10.5

Theorem [10.5.1](#) is due to [Guerre-Delabrière \[1991\]](#); it is a variant of a result of [Bourgain \[1983\]](#), treated earlier as Theorem [5.2.10](#), which derives the UMD property from the boundedness of the Hilbert transform instead of that of $(-\Delta)^{is}$. The quantitative bound given in Theorem [10.5.1](#) is not stated by [Guerre-Delabrière \[1991\]](#), but it is implicit in her argument; this was observed in [Hytönen \[2007b\]](#).

Proposition [10.5.4](#) is due to [Hytönen and Weis \[2008\]](#), but the present quantitative statement ‘with constant 1’ is new. The ergodic Lemma [10.5.6](#), which is a standard result from ergodic theory adapted from [Katok and Hasselblatt \[1995\]](#), replaces in the present treatment an ad hoc argument in [Hytönen and Weis \[2008\]](#) to approximate arbitrary coefficients $\alpha_{jk} = \pm 1$ as in the real version of Pisier’s contraction property.

Section 10.6

Among the many works on bisectorial operators we mention [Albrecht, Duong, and McIntosh \[1996\]](#), [Auscher, McIntosh, and Nahmod \[1997\]](#), [Arendt and Bu \[2005\]](#), [Dore and Venni \[2005\]](#), [Duelli and Weis \[2005\]](#), [Axelsson, Keith, and McIntosh \[2006\]](#), [Arendt and Duelli \[2006\]](#), [Arendt and Zamboni \[2010\]](#), [Egert \[2015\]](#).

Alongside with id/dx , important examples of a bisectorial operators are the Hodge–Dirac operator D of Example [10.6.5](#) and its perturbation AD , given by

$$D := \begin{pmatrix} 0 & -\operatorname{div} \\ \nabla & 0 \end{pmatrix}, \quad AD = \begin{pmatrix} 1 & 0 \\ 0 & B \end{pmatrix} D = \begin{pmatrix} 0 & -\operatorname{div} \\ B\nabla & 0 \end{pmatrix},$$

where the operators act in $L^2(\mathbb{R}^d) \oplus L^2(\mathbb{R}^d; \mathbb{R}^d)$, and B is (the pointwise multiplication by) a matrix-valued function with suitable ellipticity assumptions. These operators were used in the seminal paper of [Axelsson, Keith, and McIntosh \[2006\]](#) to give a new proof and several extensions of the Kato square root conjecture,

$$\|\sqrt{L}u\|_{L^2(\mathbb{R}^d)} \approx \|\nabla u\|_{L^2(\mathbb{R}^d;\mathbb{R}^d)}, \quad L := -\operatorname{div} B\nabla,$$

originally solved by [Auscher, Hofmann, Lacey, McIntosh, and Tchamitchian \[2002\]](#). The estimate above is formally the boundedness, and boundedness from below, of $\nabla L^{-1/2}$, which can be seen as a component of the matrix $\operatorname{sgn}(AD)$ for the holomorphic function $\operatorname{sgn}(z) := z/\sqrt{z^2}$.

Related work on Hodge–Dirac operators include applications to boundary value problems by [Auscher, Axelsson, and Hofmann \[2008\]](#), [Amenta and Auscher \[2016\]](#), [Auscher and Stahlhut \[2016\]](#), the Stokes operator by [McIntosh and Monniaux \[2016\]](#), non-symmetric Ornstein-Uhlenbeck operators by [Maas and Van Neerven \[2009\]](#), and spin manifolds by [Bandara, McIntosh, and Rosén \[2016\]](#), [Bandara and Rosén \[2017\]](#).

The new proof of the Kato conjecture by [Axelsson, Keith, and McIntosh \[2006\]](#) using first-order methods was extended to the setting of $L^p(\mathbb{R}^d; X)$ by [Hytönen, McIntosh, and Portal \[2008a\]](#); here X is required to be a UMD space and in addition to satisfy the RMF property, discussed in [Section 3.6.b](#), which was in fact first invented for the purposes of this paper. Besides the X -valued extension, this paper offered an alternative approach to the L^p theory of the Kato conjecture, which has been further explored by [Auscher and Stahlhut \[2013\]](#), [Frey, McIntosh, and Portal \[2014\]](#), [Hytönen and McIntosh \[2010\]](#), and [Hytönen, McIntosh, and Portal \[2011\]](#).

Section 10.7

Both Transference Theorems [10.7.5](#) and [10.7.9](#) are due to [Coifman and Weiss \[1976\]](#). Important contributions to vector-valued extensions of [Theorem 10.7.5](#) include [Berkson, Gillespie, and Muhly \[1986, 1989\]](#), [Asmar, Berkson, and Gillespie \[1990\]](#). [Theorem 10.7.10](#) is due to [Hieber and Prüss \[1998\]](#). Our approach via the Phillips calculus is inspired by [Haase \[2006, Chapter 3\]](#), where the formula [\(10.45\)](#) appears. Extensions of [Theorems 10.7.9](#) and [10.7.10](#) to unbounded C_0 -groups are obtained in [Haase \[2007, 2009\]](#), and to general C_0 -semigroups in [Haase \[2011\]](#). Among others, in the latter paper it is shown that if $(S(t))_{t \geq 0}$ is any C_0 -semigroup on a Banach space X and if $g \in L^1(\mathbb{R}_+)$ has support in $[a, b] \subseteq (0, \infty)$, then

$$\left\| \int_0^\infty g(t)S(t)x \, dt \right\| \lesssim_p (1 + \log(b/a)) \left(\sup_{t \geq 0} \|S(t)\| \right)^2 \|K_g\|_{\mathcal{L}(L^p(\mathbb{R}_+; X))},$$

where K_g denotes convolution with g . This result is subsequently used to deduce a continuous-time version of results of [Peller \[1982\]](#) and [Vitse \[2005\]](#) providing bounds for the Phillips calculus $\Psi_A(f)$ for the generators $-A$ of polynomially bounded C_0 -semigroups in terms of suitable Besov norms of f . Further extensions and consequences of [Haase \[2011\]](#) can be found in [Haase and Rozendaal \[2013\]](#), [Schwenninger \[2016a\]](#). An extension of the Phillips functional calculus using techniques from systems theory has been obtained in

Zwart [2012] in a Hilbert space setting. It has been extended to the Banach space setting by Schwenninger and Zwart [2012].

Our proof of the second Transference Theorem 10.7.9, on positive contractions on L^p , essentially follows the original one from Coifman and Weiss [1976]. This has the advantage, over another variant explained shortly, that one only needs the Akcoglu–Sucheston Dilation Theorem I.1.2 for the finite-dimensional spaces ℓ_n^p , and not the general version for L^p -spaces (which is obtained from the ℓ_n^p version through ultrapower techniques). A shortcut to Theorem 10.7.9, taken in Kunstmann and Weis [2004], is to use the Fendler’s semigroup version of the Akcoglu–Sucheston theorem:

Theorem 10.8.1 (Fendler). *Every C_0 -semigroup of positive contractions on a space $L^p(S, \mu)$ with $1 < p < \infty$ has a dilation to a C_0 -group of positive isometries on $L^p(T, \nu)$.*

To be more precise, Fendler’s theorem asserts the existence of a measure space (T, \mathcal{B}, ν) , a C_0 -group of positive isometries $(U(t))_{t \in \mathbb{R}}$ on $L^p(T, \nu)$, a positive isometric embedding $J : L^p(S, \mu) \rightarrow L^p(T, \nu)$, and a positive norm one projection P of $L^p(T, \nu)$ onto the range of J such that

$$JS(t) = PU(t)J, \quad t \geq 0.$$

The only known proof of this theorem heavily relies on ultrapower techniques.

Boundedness of the imaginary powers of the negative generator $-A \otimes I_X$ and an extension of Proposition 10.7.8 to the UMD-valued setting were obtained in Clément and Prüss [1990]. In Clément and Prüss [2001], Corollary 10.7.11 (with a different proof) was also noted.

Theorem 10.7.13 is from Kalton and Weis [2001] and was foreshadowed in Weis [2001a]; we follow the arguments in Kunstmann and Weis [2004]. This theorem has a long history. Using advanced methods from harmonic analysis, in particular square function estimates, Stein [1970b] showed (implicitly in section IV.6) that if $-A$ is the generator of a symmetric diffusion semigroup (a precise definition is given in the discussion of Problem P.4) on $L^2(S)$, where (S, \mathcal{A}, μ) is a σ -finite measure space, then A has a bounded H^∞ -calculus on $L^p(S)$ with $\omega_{H^\infty}(A) < \frac{1}{2}\pi$ for all $1 < p < \infty$. Cowling [1983] gave a more direct proof of this fact, using the Coifman–Weiss transference, and eliminated assumption $T(t)\mathbf{1} = \mathbf{1}$. Carbonaro and Dragičević [2017] obtained the bounded H^∞ -calculus of angle $\omega_{H^\infty}(A) \leq \phi_p^* := \arcsin(1 - \frac{2}{p})$, which is optimal if $S(t)$ is the Ornstein–Uhlenbeck semigroup (see García-Cuerva, Mauceri, Meda, Sjögren, and Torrea [2001, Theorem 2] and Hebisch, Mauceri, and Meda [2004, Theorem 2.2]).

In another direction, Duong and Yan [2002] and Hieber and Prüss [1998] made a big step forward by showing that A has a bounded H^∞ -calculus with $\omega_{H^\infty}(A) \leq \frac{1}{2}\pi$ if $-A$ generates a positive contractive semigroup $S(t)$ on a general L^p -space for just one $p \in (1, \infty)$. Finally it was shown in Kalton and Weis [2001], Weis [2001a] (see also Kunstmann and Weis [2004]) that,

if in addition $S(t)$ extends to an analytic C_0 -semigroup bounded on a sector Σ_δ , then $\omega_{H^\infty}(A) < \frac{1}{2}\pi$. Vector-valued extensions to special classes of UMD-spaces were obtained by Xu [2015]. The H^∞ -calculus for ‘diffusions’ on non-commutative L^p -spaces has been studied Junge, Le Merdy, and Xu [2003].

Lemma 10.7.17 is a variant of the complex interpolation of Stein [1956]; see Voigt [1992] for an abstract version.

Several dilation results have been obtained in Arhancet, Fackler, and Le Merdy [2017]. They showed that if A admits a bounded $H^\infty(\Sigma_\sigma)$ -calculus on some L^p -space, with $1 < p < \infty$, for some $0 < \sigma < \frac{1}{2}\pi$, then $(S(t))_{t \geq 0}$ dilates to a bounded analytic semigroup $(R(t))_{t \geq 0}$ a larger L^p -space in such a way that $R(t)$ is a positive contraction for all $t \geq 0$. Moreover, on reflexive Banach spaces X such that both X and X^* have finite cotype, they show that there is a dilation to a group, which has additional structure if the semigroup generated by $-A$ is positive, or if $X = L^p$. These results elaborate previous results of Fröhlich and Weis [2006].

Further examples of operators with an H^∞ -calculus

Here we collect some further examples of operators with a bounded H^∞ -calculus.

Elliptic partial differential operators

Consider an elliptic system of the form

$$(Ax)(u) = \sum_{|\alpha| \leq 2m} a_\alpha(D^\alpha x)(u), \quad u \in D,$$

where D is an open domain in \mathbb{R}^d satisfying appropriate regularity conditions. For $D = \mathbb{R}^d$ and Hölder continuous coefficients, proofs of the boundedness of the H^∞ -calculus of A on $L^p(D, \mathbb{C}^n)$, $1 < p < \infty$, were given in Amann, Hieber, and Simonett [1994], Denk, Hieber, and Prüss [2003], Kalton, Kunstmann, and Weis [2006], for continuous coefficients in Duong and Simonett [1997], and for VMO-coefficients in Duong and Yan [2002], Heck and Hieber [2003]. Boundedness of the H^∞ -calculus of elliptic operators satisfying suitable kernel bounds on rather general classes of metric measure spaces was shown in Duong and Robinson [1996], Duong and McIntosh [1999]. In Denk, Dore, Hieber, Prüss, and Venni [2004] it was shown that the L^p -realisation of a sectorial operator governing an UMD-valued elliptic boundary value problem with Lopatinskij–Shapiro boundary conditions admits a bounded H^∞ -calculus on $L^p(D; X)$ for all $1 < p < \infty$, provided the top-order coefficients of A are Hölder continuous and the domain G in \mathbb{R}^d has compact C^{2m} -boundary. The proof is based on kernel estimates and a perturbation result for operators admitting bounded H^∞ -calculus. Nau and Saal [2012] obtained improvements of some of these results in the special setting of cylindrical domains of the

form $\Omega = V_1 \times \dots \times V_n \subseteq \mathbb{R}^d$, where each $V_i \subseteq \mathbb{R}^{d_i}$ is a regular domain and $d_1 + \dots + d_n = d$.

In a different direction, the work of [Duong and Robinson \[1996\]](#), [Duong and McIntosh \[1999\]](#) was generalised in [Blunck and Kunstmann \[2003\]](#), where it was shown that kernel estimates can be replaced by *weighted norm estimates* (also referred to as *off-diagonal bounds* or *Davies–Gaffney estimates*). For fixed $1 \leq p < 2 < q \leq \infty$ assume that

$$\|\mathbf{1}_{B(u, t^{1/m})} S(t) \mathbf{1}_{B(v, t^{1/m})}\|_{L^p \rightarrow L^q} \leq \frac{1}{|B(x, t^{1/m})|^{1/p-1/q}} g\left(\frac{d(u, v)}{t^{1/m}}\right) \quad (10.58)$$

for all $t > 0$ and $u, v \in D$, where $g : [0, \infty) \rightarrow [0, \infty)$ is a non-increasing function that decays faster than any polynomial and $(S(t))_{t \geq 0}$ is the bounded analytic C_0 -semigroup generated by $-A$ on $L^2(D)$. Then (10.58) implies that A has a bounded H^∞ -calculus on $L^s(D)$ for all $s \in (p, q)$. Moreover, denoting by A_s the realisation of A on $L^s(D)$, one has $\omega_{H^\infty}(A_s) = \omega_{H^\infty}(A) = \omega(A)$. This allows the treatment of various classes of examples that cannot be treated via kernel estimate, such as Schrödinger operator with a singular potential, elliptic higher order operators with bounded measurable coefficients, and elliptic second order operator with singular lower order terms. This techniques is very flexible and has proved to be of use in a wide range of applications.

Stokes operators

For a bounded domain $\Omega \subseteq \mathbb{R}^d$ with a smooth boundary $\partial\Omega$ we denote by P_p the Helmholtz projection of $L^p(\Omega)^d$ onto the Helmholtz space $L^{p,\sigma}(\Omega)^d$ of divergence-free vector fields, $1 < p < \infty$. The *Stokes operator* then is defined by $A_p = P_p \Delta$ with Dirichlet boundary values. The boundedness of the H^∞ -calculus of A_p is shown in [Noll and Saal \[2003\]](#) and [Kalton, Kunstmann, and Weis \[2006\]](#) and, based on maximal regularity results, in [Fröhlich \[2001\]](#). For earlier results on bounded imaginary powers for Stokes operators see [Giga \[1985\]](#). Since then the boundedness of the H^∞ -calculus of the Stokes operator and its variants have also been considered on certain unbounded domains with various boundary conditions, see e.g. [Abels \[2005a,b\]](#), [Abels and Terasawa \[2009\]](#), [Farwig and Myong-Hwan \[2007\]](#), [Geißert and Kunstmann \[2015\]](#), [Giga, Gries, Hieber, Hussein, and Kashiwabara \[2017\]](#), [Kunstmann \[2008\]](#), [Maier and Saal \[2014\]](#), [Prüss and Simonett \[2016\]](#). For Lipschitz domains, the Stokes operator only operates - and has a bounded H^∞ -calculus, on a part of the L^p -scale, cf. [Kunstmann and Weis \[2017\]](#), [McIntosh and Monniaux \[2016\]](#).

L^1 and $C(K)$ -spaces

In $L^1(\mu)$ and $C(K)$ there are no interesting examples of unbounded operators with a bounded H^∞ -calculus, and certainly no differential operators. See [Kalton and Weis \[2001\]](#), [Hoffmann, Kalton, and Kucherenko \[2004\]](#) and [Kucherenko and Weis \[2005\]](#) for some results in this direction. This situation reflects the well known fact that singular integral operators are generally unbounded on $L^1(\mathbb{R}^d)$ -spaces and $C_b(\mathbb{R}^d)$ -spaces.

Besov spaces and Triebel–Lizorkin spaces

In [Dore \[1999, 2001\]](#) it is shown that if A is a densely defined sectorial operator with dense range on a Banach space X , then A induces sectorial operators on the real interpolation spaces $(X, D(A))_{\theta, q}$ which have a bounded H^∞ -functional calculus. If $X = L^p(\mathbb{R}^d)$ and $D(A) = W^{2,p}(\mathbb{R}^d)$, then $(X, D(A))_{\theta, q}$ equals the Besov spaces $B_{p, q}^s(\mathbb{R}^d)$ with $1 \leq p, q \leq \infty$ (see [Bergh and L ofstr om \[1976\]](#)). [Haase and Rozendaal \[2016\]](#) obtain a functional calculus for generators of bounded and unbounded groups on real interpolation spaces using functions from the analytic Mihlin algebra. In [Kalton and Kucherenko \[2010\]](#) the so-called *absolute functional calculus* was introduced for a sectorial operator A . This calculus has much stronger properties than the H^∞ -calculus. The authors show that a sectorial operator has an absolute functional calculus if and only if the underlying space is a certain real interpolation space.

[Kunstmann, P. C. and Ullmann \[2014\]](#) introduce generalised Triebel–Lizorkin spaces associated with sectorial operators in Banach function spaces and show that an ℓ^s -sectorial operator has a bounded H^∞ -functional calculus in its associated generalised Triebel–Lizorkin spaces.

The boundedness of H^∞ -calculus for pseudodifferential operators in various function spaces on manifolds with or without corners is studied in [Bilyj, Schrohe, and Seiler \[2010\]](#), [Escher and Seiler \[2008\]](#), [Coriasco, Schrohe, and Seiler \[2007\]](#), [Denk, Saal, and Seiler \[2009\]](#).

P

Problems

Random sums

The Kahane–Khintchine inequality (Theorem 6.2.4) states in particular that for all exponents $0 < p \leq q < \infty$ there exists a constant $\kappa_{q,p}^{\mathbb{R}} \leq \sqrt{\frac{q-1}{p-1}}$ such that for any Banach space X and any finite sequence $(x_n)_{n \geq 1}$ in X ,

$$\left\| \sum_{n=1}^N r_n x_n \right\|_{L^q(\Omega; X)} \leq \kappa_{q,p}^{\mathbb{R}} \left\| \sum_{n=1}^N r_n x_n \right\|_{L^p(\Omega; X)}.$$

While a universal constant $\kappa_{q,p}^{\mathbb{R}}$ works for all Banach spaces, in principle a better constant could be available for specific spaces, especially for $X = \mathbb{R}$. Let us denote this latter constant by $\kappa_{q,p,\mathbb{R}}$.

Problem P.1 (Kwapień). Prove that the optimal constant in the Kahane–Khintchine inequality for general Banach spaces the same as the constant for the real line, i.e. prove that $\kappa_{q,p}^{\mathbb{R}} = \kappa_{q,p,\mathbb{R}}$ for all $0 < p \leq q < \infty$?

There are a few cases for which the precise best constants $\kappa_{q,p}^{\mathbb{R}}$ and $\kappa_{q,p,\mathbb{R}}$ are known, and in all these cases the conjectured equalities are true. For a fuller discussion the reader is referred to the Notes of Chapter 6.

Problem P.2. Characterise the Banach spaces X for which a constant $C \geq 0$ exists such that for all sequences $(x_{mn})_{m,n=1}^{M,N}$ in X and all scalar sequences $(a_{mn})_{m,n=1}^{M,N}$ it is true that

$$\mathbb{E} \left\| \sum_{n=1}^N \gamma_n \sum_{m=1}^M a_{mn} x_{mn} \right\|^2 \leq C^2 \sup_{1 \leq n \leq N} \left(\sum_{m=1}^M |a_{mn}|^2 \right) \mathbb{E} \mathbb{E}' \left\| \sum_{m=1}^M \gamma'_m \sum_{n=1}^N \gamma_n x_{mn} \right\|^2,$$

where $(\gamma_n)_{n=1}^N$ and $(\gamma'_m)_{m=1}^M$ are Gaussian sequences on distinct probability spaces (Ω, \mathbb{P}) and (Ω', \mathbb{P}') .

According to Remark 9.6.15, the above estimate holds for Banach spaces X that have either Pisier's contraction property (Corollary 9.6.12) or non-trivial type (Theorem 9.6.14). It should be observed that neither one of these properties implies the other.

As explained in Example 9.6.17, the validity of this estimate implies R -boundedness of Laplace transforms in the right half-plane.

The relation of type and Enflo-type

Problem P.3 (Enflo [1978]). If a Banach space has type $p \in (1, 2]$, does it also have Enflo-type p (see Definition 7.6.9)?

This problem has been implicitly raised by Enflo [1978] and partially answered by Pisier [1986a] and Naor and Schechtman [2002]. They proved, respectively, that the assumption implies every Enflo-type $p_1 \in [1, p]$ in general, and Enflo-type p if the space is also assumed to be UMD; see Theorem 7.6.10. The general case remains open.

Analyticity of diffusion semigroups and K -convexity

Let (S, \mathcal{A}, μ) be a σ -finite measure space. A family $(T(t))_{t \geq 0}$ of linear operators on $L^2(S)$ is called a *symmetric diffusion semigroup* if it is a C_0 -semigroup on $L^2(S)$ and the following conditions are satisfied for all $t \geq 0$:

- (i) $T(t)$ is a contraction on $L^p(S)$ for all $1 \leq p \leq \infty$;
- (ii) $T(t)$ is self-adjoint on $L^2(S)$;
- (iii) $T(t)$ is a positive operator;
- (iv) $T(t)\mathbf{1} = \mathbf{1}$.

To be sure, in (i) we are asking that $\|T(t)f\|_p \leq \|f\|_p$ for all $f \in L^p(S) \cap L^2(S)$. The strong continuity on $L^2(S)$, together with properties (i) and (ii), implies that $(T(t))_{t \geq 0}$ is a C_0 -semigroup on $L^p(S)$ for all $p \in [1, \infty)$; on $L^\infty(S)$ the semigroup is weak*-continuous. Property (ii) implies moreover that $(T(t))_{t \geq 0}$ has an extension to an analytic C_0 -semigroup of contractions of angle $\frac{1}{2}\pi$ on $L^2(S)$, and then the Stein interpolation theorem implies that $(T(t))_{t \geq 0}$ is an analytic C_0 -contraction semigroup on $L^p(S)$ for all $p \in (1, \infty)$ (with an angle depending on p). The details can be found in Stein [1970b].

For any Banach space X , the tensor extensions $T(t) \otimes I_X$, $t \geq 0$, define a contractive C_0 -semigroup on $L^p(S; X)$ by Theorem 2.1.3.

Problem P.4 (Pisier [1982]). Let $(T(t))_{t \geq 0}$ be a symmetric diffusion semigroup on $L^2(S)$. Does $(T(t) \otimes I_X)_{t \geq 0}$ extend to an analytic C_0 -semigroup on $L^p(S; X)$ for all $p \in (1, \infty)$ and all K -convex Banach spaces X ?

A key ingredient in the proof of Pisier's K -convexity Theorem 7.4.23 was the positive resolution of this problem for the special case of the discrete heat semigroup; the original argument of Pisier [1982] spells this out under more general structural assumptions on the semigroup, namely, when $(T(t))_{t \geq 0}$ is

a convolution semigroup on a compact Abelian group $S = G$, but not in the full generality asked in Problem P.4. The same proof also gives an affirmative answer for all diffusion semigroups under a stronger condition on the space X , e.g., if X is uniformly convex or super-reflexive (and in particular if X is a UMD space). This might be taken as evidence for a positive answer in full generality, as already speculated by Pisier [1982]. Further progress on the above problem was recently made in Arhancet [2015].

On the K -convexity constant

Problem P.5. Suppose the Banach space X has type $1 < p < 2$. Do there exist constants $\theta(p) > 0$ and $C(p) > 0$ such that the K -convexity constant satisfies $K_{2,X} \leq C(p)\tau_{p,X}^{\theta(p)}$?

The case $p = 2$ was treated in Propositions 7.4.21 and 7.4.22 where the result even holds with $\theta(2) = 1$. Theorem 7.4.28 provides an exponential bound for $p \in (1, 2)$. In Proposition 4.3.10 we have seen that for all $p \in (1, \infty)$, $K_{p,X} \leq \beta_{p,X}$, where $\beta_{p,X}$ is the UMD_p constant of X .

The vector-valued Marcinkiewicz Multiplier Theorem

It follows from the vector-valued Marcinkiewicz Multiplier Theorem 8.3.4 that for a function m which has uniformly bounded variation over the intervals

$$I \in \mathcal{I} := \{(2^k, 2^{k+1}), (-2^{k+1}, -2^k) : k \in \mathbb{Z}\},$$

the Fourier multiplier operator T_m is bounded on $L^p(\mathbb{R}; X)$ whenever X is a UMD space and $p \in (1, \infty)$. Extending the definition of bounded variation from Definition 8.3.2, we say that a function $f : I \rightarrow \mathbb{K}$ has *bounded s -variation*, for a given $s \in [1, \infty)$, if

$$\|f\|_{\dot{V}^s(I)} := \sup_{K \geq 0} \sup_{\substack{t_0, t_1, \dots, t_K \in I \\ t_0 < t_1 < \dots < t_K}} \sum_{k=1}^K |f(t_{k-1}) - f(t_k)|^s < \infty.$$

We then write $f \in V^s(I)$ and define the norm of f by

$$\|f\|_{V^s(I)} := \|f\|_{\dot{V}^s(I)} + \sup_{t \in I} |f(t)|.$$

Moreover, for $m : \mathbb{R} \rightarrow \mathbb{K}$ we write $m \in V^s(\mathcal{I})$ if $\sup_{I \in \mathcal{I}} \|m\|_{V^s(I)} < \infty$, where \mathcal{I} is as above. Observe that $V^{s_0}(\mathcal{I}) \subseteq V^{s_1}(\mathcal{I})$ if $1 \leq s_0 \leq s_1 < \infty$.

Problem P.6. Let X be a UMD space. Do there exist $p, s \in (1, \infty)$ such that for every $m \in V^s(\mathcal{I})$, the operator T_m is bounded on $L^p(\mathbb{R}; X)$?

It would be interesting to investigate the dependence of p and s on the geometry of X . In the case $X = \mathbb{C}$, [Coifman, Rubio de Francia, and Semmes \[1988\]](#) proved that T_m is bounded whenever $m \in V^s(\mathcal{I})$ and $p \in (1, \infty)$ and $s \in (2, \infty)$ satisfy $\frac{1}{s} > \left| \frac{1}{p} - \frac{1}{2} \right|$. An extension to Banach spaces with the so-called Littlewood–Paley–Rubio de Francia property (see page 481 in the Notes of Chapter 5) was obtained in [Hytönen and Potapov \[2006\]](#). Some of these results have been strengthened in [Amenta, Lorist, and Veraar \[2017a,b\]](#) for Banach lattices X whose q -concavification has the UMD property.

R-sectoriality of the Laplacian

For UMD spaces X and $1 < p < \infty$, by [Theorem 10.2.25](#) the operator $-\Delta$ has a bounded H^∞ -calculus on $L^p(\mathbb{R}^d; X)$, and [Theorem 10.3.4\(2\)](#) implies that $-\Delta$ is R -sectorial. Observe that $L^p(\mathbb{R}^d; X)$ has the triangular contraction property if X has it, and UMD spaces always have this property (see [Proposition 7.5.8](#) and [Theorem 7.5.9](#)), so the application of [Theorem 10.3.4\(2\)](#) is justified. In the converse direction, the UMD property is necessary for the bounded H^∞ -calculus of $-\Delta$ on $L^p(\mathbb{R}^d; X)$ by [Corollary 10.5.2](#). The following, however, is open:

Problem P.7. Does R -sectoriality of $-\Delta$ on $L^p(\mathbb{R}; X)$ imply that X is a UMD space? If not, which other spaces X are admissible?

The same question can be asked about the first derivative d/dx . Rather more vaguely, one can ask whether there exists some “mechanism” to deduce unconditionality from R -boundedness, in analogy with, but reversing the direction, of [Proposition 8.4.6](#).

γ -boundedness and radonifying operators

When working with R -boundedness, it is sometimes handy that, in place of arbitrary tuples (T_1, \dots, T_N) of operators, it is sufficient to consider distinct choices of T_n (see [Proposition 8.1.5](#)). The proof of this result depends on the multiplicative properties of the Rademacher variables, and its Gaussian analogue is open:

Problem P.8. Do we get an equivalent definition of γ -boundedness, if we require the defining estimate for distinct choices of operators only, i.e., does the γ -boundedness analogue of [Proposition 8.1.5](#) hold? If not, what is an example of a collection that satisfies the defining estimate for distinct operators, but fails to be γ -bounded.

Since γ -boundedness coincides with R -boundedness in spaces of finite cotype ([Theorem 8.6.4](#)), the example would have to live in a space without cotype. The proof of [Theorem 8.6.4](#) produces an example of an R -bounded, but not γ -bounded family of operators, and one can readily check that the proof already shows the failure of the restricted γ -boundedness with distinct operators only; thus a more refined example would be required for a negative solution of [Problem P.8](#).

Problem P.9. Theorem 9.5.1 asserts that every strongly μ -measurable function $M : S \rightarrow \mathcal{L}(X, Y)$ with γ -bounded range acts as a pointwise multiplier from $\gamma(L^2(S), X)$ into $\gamma_\infty(L^2(S), Y)$. Does M always take its values in the smaller space $\gamma_\infty(L^2(S), Y)$?

Inspecting the proof of Theorem 9.5.1 one sees that the main culprit is the application of the γ -Fatou lemma (Proposition 9.4.6). Easy examples show that in this lemma the limit will in general fail to be γ -radonifying. Thus, a positive answer will either require a new proof avoiding the γ -Fatou lemma or an additional argument which explains why M takes values in $\gamma(L^2(S), Y)$ rather than just in $\gamma_\infty(L^2(S), Y)$.

In most applications, Theorem 9.5.1 is applied in the context of UMD spaces Y , which do not contain copies of c_0 ; by Theorem 6.4.10 one then has $\gamma_\infty(L^2(S), Y) = \gamma(L^2(S), Y)$. In other applications one can give *ad hoc* arguments to prove membership in $\gamma(L^2(S), Y)$, for instance as an application of Corollary 9.5.2.

The H^∞ -functional calculus and square function estimates

Theorems 10.4.25 and 10.4.27 give a subtle improvement of the square function estimate of Theorem 10.4.16(1) for spaces X with finite cotype, in that they are stated in terms of $H^2(\Sigma)$ rather than $H^1(\Sigma)$. It is not known whether a similar improvement of the dual estimate of Theorem 10.4.16(2) holds for general Banach spaces X .

Problem P.10 (Dual estimate for the quadratic H^∞ -calculus). Let A be a densely defined sectorial operator with dense range on a Banach space X , and assume that A has a bounded $H^\infty(\Sigma_\sigma)$ -functional calculus for some $\omega(A) < \sigma < \pi$. Let H be a Hilbert space, let $\sigma < \vartheta < \pi$, and define, for $F \in H^\infty(\Sigma_\vartheta; H^*)$, the operator $F(A^*) : X^* \rightarrow \mathcal{L}(H, X^*)$ by

$$[F(A^*)x^*]h := \langle h, F \rangle(A^*)x^*, \quad h \in H, \quad x^* \in \mathcal{D}(A^*) \cap \mathcal{R}(A^*).$$

Is it true that $F(A^*)$ extends to a linear bounded mapping from X^* into $\gamma^*(H, X^*)$ and

$$\|F(A^*)x^*\|_{\gamma^*(H, X^*)} \leq C_{\sigma, \vartheta, A} \|F\|_{H^\infty(\Sigma_\sigma; H^*)}, \quad x^* \in \mathcal{D}(A^*) \cap \mathcal{R}(A^*).$$

It follows from Theorem 10.4.25 applied to A^* that the answer is affirmative under the additional assumption that X^* has finite cotype. In that case a stronger version of the result holds where $\gamma^*(H, X^*)$ is replaced by $\gamma(H, X^*)$ (see Proposition 9.1.22). Note that if X has non-trivial type, then $\gamma^*(H, X^*) = \gamma(H, X^*)$ (see Proposition 9.1.23).

Functional calculus for generators of diffusion semigroups

Let $(T(t))_{t \geq 0}$ be a diffusion semigroup on $L^2(S)$ in the sense of Problem P.4. Let us fix a Banach space X and an exponent $1 \leq p < \infty$, and denote the generator of the C_0 -semigroup $(T(t) \otimes I_X)_{t \geq 0}$ on $L^p(S; X)$ by $-A_X$.

Problem P.11 (Xu [2015]). Is it true that if X is a UMD space, then $\omega_{H^\infty}(A_X) < \frac{1}{2}\pi$ or even $\omega_{H^\infty}(A_X) = \omega(A_X) < \frac{1}{2}\pi$?

Recall from Theorem 10.7.12 that A_X has a bounded H^∞ -calculus with $\omega_{H^\infty}(A) \leq \frac{1}{2}\pi$. By Proposition 10.3.3 and Corollary 10.4.10, the above problem can be equivalently formulated as follows: Does there exist a $\delta > 0$ such that the set $\{T(z) \otimes I_X : |\arg z| < \delta\}$ is R -bounded? (As in the discussion of Problem P.7 we observe that $L^p(S; X)$ has the triangular contraction property). The R -boundedness for $z = t \in [0, \infty)$ is known to hold. Indeed, Hytönen, Li, and Naor [2016, Corollary 21] state this for the heat semigroup on \mathbb{R}^d , but the same proof (based on Rota's theorem) works for any symmetric diffusion semigroup.

It follows from the results in Xu [2015] that the answer to Problem P.11 is affirmative for UMD spaces X that are a complex interpolation space between a Hilbert space and some other UMD space. This brings a connection with Problem O.3, which asks whether every UMD space has this form. Among other examples, an affirmative answer is known for all UMD lattices (see Rubio de Francia [1986]).

The role of positivity and contractivity

Problem P.12 (Fackler [2015]). Let $-A$ generate a C_0 -semigroup $(S(t))_{t \geq 0}$ on an L^p -space, $p \in (1, \infty) \setminus \{2\}$, which is either positive or contractive (but not necessarily both). Does A have a bounded H^∞ -calculus?

Theorem 10.7.12 shows that if $(S(t))_{t \geq 0}$ is both positive and contractive, then A has a bounded H^∞ -calculus. Moreover, for $p = 2$ contractivity suffices. Even in the case $p = 2$ it is an open problem whether positivity of the semigroup is already enough for having a bounded H^∞ -calculus.

Carbonaro and Dragičević [2017] showed that if $-A$ is the generator semigroup which satisfies (i) and (ii) in the definition of a symmetric diffusion semigroup given before Problem P.4, then A has a bounded H^∞ -calculus of angle $\omega_{H^\infty}(A) \leq \phi_p^* := \arcsin(1 - \frac{2}{p})$. No positivity is assumed, nor is it assumed that $\mathbf{1}$ is mapped to $\mathbf{1}$. In the proof, it is used that the semigroup is contractive and analytic on the sector $\Sigma_{\frac{1}{2}\pi - \phi_p^*}$, a result due to Kriegler [2011, Corollary 6.2 and Remark 2]. He also gave a strikingly simple example of 2×2 matrices that shows the optimality of the angle ϕ_p^* . The equality $\omega_{H^\infty}(A) = \phi_p^*$ is also reached in the case of the generator $-A$ of the Ornstein–Uhlenbeck semigroup; this was known earlier and is due to García-Cuerva, Mauceri, Meda, Sjögren, and Torrea [2001, Theorem 2] and Hebisch, Mauceri, and Meda [2004, Theorem 2.2].

The angle problem on L^p

Problem P.13. Let A be a sectorial operator with a bounded H^∞ -calculus on an L^p -space, for some $p \in (1, \infty)$. Is it true that $\omega(A) = \omega_{H^\infty}(A)$?

By Corollary 10.4.10 one could equivalently ask whether $\omega(A) = \omega_R(A)$. More specifically one could pose the problem for the special case where A generates a positive C_0 -contraction semigroup $(S(t))_{t \geq 0}$ on an L^p -space with $1 < p < \infty$. Such operators have a bounded H^∞ -calculus by Theorem 10.7.12.

The above problem has a negative answer on general Banach spaces. Indeed, Kalton [2003] showed that it is possible to construct, for every $\theta \in (0, \pi)$, an example of a sectorial operator A with a bounded H^∞ -calculus whose angles satisfy $\omega(A) = 0$ and $\omega_{H^\infty}(A) = \theta$. By Kalton and Weis [preprint], such example can even be given on closed subspaces of an L^p -space with $1 < p < 2$.

E

Probability theory

In this appendix we collect a number of results from elementary Probability Theory which can be formulated for random variables with values in a metric space. The treatment is tailored to our needs and only scratches the surface of what could be said in this context.

E.1 Random variables

Let E be a separable metric space.

Definition E.1.1. *An E -valued random variable is a measurable function $\xi : \Omega \rightarrow E$, where $(\Omega, \mathcal{F}, \mathbb{P})$ is a probability space, and measurability means that $\{\xi \in B\} \in \mathcal{F}$ for every Borel set (equivalently, of every open set) in E .*

Unless stated otherwise, all random variables will be defined on a probability space $(\Omega, \mathcal{F}, \mathbb{P})$ which we consider to be fixed once and for all.

Remark E.1.2 (Random variables with values in a Banach space). Since E is assumed to be a separable metric space, a function $\xi : \Omega \rightarrow E$ is measurable if and only if it is *strongly measurable*, i.e., there exists a sequence of measurable simple functions converging to f pointwise. This can be proved by repeating the argument of Corollary 1.1.10. It is mainly for this reason that we restrict our definition to separable metric spaces.

As a consequence, a function with values in a separable Banach space is a random variable if and only if it is strongly measurable. If X is a general Banach space, we *define* an X -valued random variable to be a strongly measurable function $\xi : \Omega \rightarrow X$. Such a function is always separably-valued, and therefore it is a random variable in the sense of Definition E.1.1 if we replace X by any separable closed subspace of X containing the range of ξ .

Lemma E.1.3 (Borel–Cantelli). *Let (S, \mathcal{A}, μ) be a measure space. If $(A_n)_{n \geq 1}$ is a sequence in \mathcal{A} satisfying $\sum_{n \geq 1} \mu(A_n) < \infty$, then*

$$\mu\left(\bigcap_{k \geq 1} \bigcup_{n \geq k} A_n\right) = 0.$$

The converse holds if (S, \mathcal{A}, μ) is a probability space and the sets A_n are independent.

Proof. Fix $k_0 \geq 1$. Then $\mu\left(\bigcap_{k \geq 1} \bigcup_{n \geq k} A_n\right) \leq \mu\left(\bigcup_{n \geq k_0} A_n\right) \leq \sum_{n \geq k_0} \mu(A_n)$, and the right-hand side tends to 0 as $k_0 \rightarrow \infty$.

Suppose now that (S, \mathcal{A}, μ) is a probability space and $(A_n)_{n \geq 1}$ is a sequence independent sets in \mathcal{A} satisfying $\sum_{n \geq 1} \mu(A_n) < \infty$. Using the inequality $1 - x \leq \exp(-x)$, we have

$$\begin{aligned} \mu\left(\bigcup_{n \geq k} A_n\right) &= 1 - \mu\left(\bigcap_{n \geq k} \mathbb{C}A_n\right) = 1 - \prod_{n \geq k} \mu(\mathbb{C}A_n) \\ &\geq 1 - \prod_{n \geq k} \exp(-\mu(A_n)) = 1 - \exp\left(-\sum_{n \geq k} \mu(A_n)\right). \end{aligned}$$

Passing to the limit $k \rightarrow \infty$ gives

$$\mu\left(\bigcap_{k \geq 1} \bigcup_{n \geq k} A_n\right) = \lim_{k \rightarrow \infty} \mu\left(\bigcup_{n \geq k} A_n\right) = 1.$$

□

E.1.a Modes of convergence

In the absence of integrability properties, at least three natural notions of convergence of random variables can be distinguished: pointwise convergence, convergence in probability, and convergence in distribution. We shall discuss these notions and their relations in some detail.

Definition E.1.4. Let $(\xi_n)_{n \geq 1}$ be a sequence of E -valued random variables, and ξ be another E -valued random variable.

(1) $(\xi_n)_{n \geq 1}$ converges in probability to ξ (resp. is Cauchy in probability) if

$$\mathbb{P}(d(\xi_n, \xi) > r) \rightarrow 0 \quad \left(\text{resp. } \mathbb{P}(d(\xi_n, \xi_m) > r) \rightarrow 0\right)$$

for all $r > 0$ as $n \rightarrow \infty$ (resp. $n, m \rightarrow \infty$).

(2) $(\xi_n)_{n \geq 1}$ converges in distribution to ξ if

$$\mathbb{E}f(\xi_n) \rightarrow \mathbb{E}f(\xi)$$

for all $f \in C_b(E)$, the space of bounded continuous functions $f : E \rightarrow \mathbb{K}$.

Clearly, if $\xi_n \rightarrow \xi$ in distribution in E , and if ϕ is a continuous mapping from E into another metric space F , then $\phi(\xi_n) \rightarrow \phi(\xi)$ in distribution in F .

The main relations between these notions are summarised in the following proposition. Some of these implications have already been considered in Appendix A.2 in the case of scalar-valued function. While the metric space versions hardly differ except in notation, we include the short proofs for completeness.

Proposition E.1.5. *Let $(\xi_n)_{n \geq 1}$ be a sequence of E -valued random variables, and ξ be another E -valued random variable.*

- (1) *If $\xi_n \rightarrow \xi$ almost everywhere (a.e.), then $\xi_n \rightarrow \xi$ in probability.*
- (2) *If $\xi_n \rightarrow \xi$ in probability, then $\xi_{n_k} \rightarrow \xi$ a.e. along a subsequence.*
- (3) *If $\xi_n \rightarrow \xi$ in probability, then $\xi_n \rightarrow \xi$ in distribution.*
- (4) *If $(\xi_n)_{n \geq 1}$ is Cauchy in probability, then a subsequence $(\xi_{n_k})_{k \geq 1}$ is Cauchy a.e.*
- (5) *If E is complete and $(\xi_n)_{n \geq 1}$ is Cauchy in probability, it converges in probability.*

Proof. (1): Suppose that $\xi_n \rightarrow \xi$ almost everywhere. Then $\mathbf{1}_{\{d(\xi_n, \xi) > r\}} \rightarrow 0$ almost everywhere, and

$$\mathbb{P}(d(\xi_n, \xi) > r) = \mathbb{E} \mathbf{1}_{\{d(\xi_n, \xi) > r\}} \rightarrow 0$$

by dominated convergence, which proves convergence in probability.

(2): If ξ_n converges to ξ in probability, we inductively pick $n_k > n_{k-1}$ such that $\mathbb{P}(A_k) := \mathbb{P}(d(\xi_{n_k}, \xi) > 2^{-k}) < 2^{-k}$. Since $\sum_{k \geq 1} \mathbb{P}(A_k) < \infty$, it follows that almost every $\omega \in \Omega$ belongs to $\mathcal{C}A_k$ for all $k \geq K(\omega)$. But this means that $d(\xi_{n_k}, \xi) \leq 2^{-k}$ for all $k \geq K(\omega)$, which clearly implies that $\xi_{n_k} \rightarrow \xi$ at such a point ω .

(3): Let $\lim_{n \rightarrow \infty} \xi_n = \xi$ in probability. By (2), any subsequence $(\xi_{n_k})_{k \geq 1}$ has a further subsequence $(\xi_{n_{k_j}})_{j \geq 1}$ which converges almost everywhere. By the dominated convergence theorem, for all $f \in C_b(E)$ we then have $\lim_{j \rightarrow \infty} \mathbb{E} f(\xi_{n_{k_j}}) = \mathbb{E} f(\xi)$. It follows that $\lim_{n \rightarrow \infty} \xi_n = \xi$ in distribution.

(4): If $(\xi_n)_{n \geq 1}$ is Cauchy in probability, we inductively pick $n_k > n_{k-1}$ such that $\mathbb{P}(d(\xi_n, \xi_m) > 2^{-k}) < 2^{-k}$ for all $n, m \geq n_k$. Then in particular $\mathbb{P}(B_k) := \mathbb{P}(d(\xi_{n_k}, \xi_{n_{k+1}}) > 2^{-k}) < 2^{-k}$. As in Part (2), this implies that at almost every $\omega \in \Omega$, we have $d(\xi_{n_k}, \xi_{n_{k+1}}) \leq 2^{-k}$ for all $k \geq K(\omega)$, which clearly implies that $(\xi_{n_k})_{k \geq 1}$ is Cauchy at such a point ω .

(5): If $(\xi_n)_{n \geq 1}$ is Cauchy in probability, by (4) a subsequence $(\xi_{n_k})_{k \geq 1}$ is Cauchy almost everywhere, and hence convergent a.e. to some ξ by completeness. In particular $\xi_{n_k} \rightarrow \xi$ in probability by (1). Thus

$$\mathbb{P}(d(\xi_m, \xi) > r) \leq \mathbb{P}(d(\xi_m, \xi_{n_k}) > r/2) + \mathbb{P}(d(\xi_{n_k}, \xi) > r/2)$$

converges to 0 as $m \rightarrow \infty$ and $k \rightarrow \infty$. □

We define $L^0(\Omega; E)$ as the set of equivalence classes of random variables on Ω with values in E , identifying random variables when they are equal almost everywhere. This space is a metric space with respect to the distance function

$$\delta(\xi, \eta) := \mathbb{E}(d(\xi, \eta) \wedge 1).$$

Proposition E.1.6. *We have $\lim_{n \rightarrow \infty} \xi_n = \xi$ in probability if and only if $\lim_{n \rightarrow \infty} \delta(\xi_n, \xi) = 0$. If E is complete, the space $L^0(\Omega; E)$ is a complete metric space with respect to δ .*

Proof. If $(\xi_n)_{n \geq 1}$ converges to ξ in probability, then any subsequence $(\xi_{n_k})_{k \geq 1}$ has a further subsequence $(\xi_{n_{k_j}})_{j \geq 1}$ which converges to ξ almost surely. For this subsequence we have $\lim_{j \rightarrow \infty} \mathbb{E}(1 \wedge d(\xi_{n_{k_j}}, \xi)) = 0$ by dominated convergence. It follows that $\lim_{n \rightarrow \infty} \mathbb{E}(1 \wedge d(\xi_n, \xi)) = 0$. The converse follows from

$$\mathbb{P}(d(\xi_n, \xi) > r) \leq \mathbb{P}(1 \wedge d(\xi_n, \xi) \geq 1 \wedge r) \leq \frac{1}{1 \wedge r} \mathbb{E}(1 \wedge d(\xi_n, \xi)).$$

This proves the first assertion.

The completeness of $L^0(\Omega; E)$ follows from the fact, proved in Proposition E.1.5, that a sequence $(\xi_n)_{n \geq 1}$, which is Cauchy in probability, is also convergent in probability. \square

Recall that a family of random variables $\{\xi_i : i \in I\}$ is *uniformly integrable* if and only if

$$\lim_{r \rightarrow \infty} \sup_{i \in I} \mathbb{E}(\mathbf{1}_{\{|\xi_i| > r\}} |\xi_i|) \rightarrow 0.$$

Proposition E.1.7. *Let $(\xi_n)_{n \geq 1}$ be a uniformly integrable sequence of non-negative random variables. If $(\xi_n)_{n \geq 1}$ converges to the random variable ξ in distribution, then ξ is integrable and $\lim_{n \rightarrow \infty} \mathbb{E}\xi_n = \mathbb{E}\xi$.*

Proof. Fix $r > 0$. Since $f(x) = x \wedge r$ is bounded and continuous, we have

$$\mathbb{E}(\xi \wedge r) = \lim_{n \rightarrow \infty} \mathbb{E}(\xi_n \wedge r) \leq \liminf_{n \rightarrow \infty} \mathbb{E}\xi_n.$$

Letting $r \rightarrow \infty$, we see that one always has $\mathbb{E}\xi \leq \liminf_{n \rightarrow \infty} \mathbb{E}\xi_n$. By the uniform integrability, the left hand side is finite, and therefore $\mathbb{E}\xi < \infty$.

Next we prove the convergence. For fixed $r > 0$,

$$|\mathbb{E}\xi - \mathbb{E}\xi_n| \leq |\mathbb{E}(\xi) - \mathbb{E}(\xi \wedge r)| + |\mathbb{E}(\xi \wedge r) - \mathbb{E}(\xi_n \wedge r)| + |\mathbb{E}(\xi_n \wedge r) - \mathbb{E}(\xi_n)|.$$

Fix an $\varepsilon > 0$. Since $\xi_n \rightarrow \xi$ in distribution, we have $\lim_{n \rightarrow \infty} |\mathbb{E}(\xi \wedge r) - \mathbb{E}(\xi_n \wedge r)| = 0$. By the uniform integrability of $(\xi_n)_{n \geq 1}$, we can find $r_1 > 0$ such that for all $r \geq r_1$ one has

$$\sup_{n \geq 1} |\mathbb{E}(\xi_n \wedge r) - \mathbb{E}(\xi_n)| \leq \sup_{n \geq 1} \mathbb{E}(\mathbf{1}_{\{\xi_n > r_1\}} \xi_n) < \varepsilon.$$

Choose r_2 such that for all $r \geq r_2$ we have $|\mathbb{E}(\xi) - \mathbb{E}(\xi \wedge r)| < \varepsilon$. Taking $r := r_1 \vee r_2$, we obtain $\limsup_{n \rightarrow \infty} |\mathbb{E}\xi - \mathbb{E}\xi_n| < 2\varepsilon$. Since $\varepsilon > 0$ was arbitrary, this completes the proof. \square

E.1.b Independence

Definition E.1.8. Suppose that I is an index set and that E_i , $i \in I$, are metric spaces. The random variables $\xi_i : \Omega \rightarrow E_i$, $i \in I$, are independent if for all choices of distinct indices $i_1, \dots, i_N \in I$ and all Borel sets $B_1 \subseteq E_{i_1}, \dots, B_N \subseteq E_{i_N}$ we have

$$\mathbb{P}(\xi_{i_1} \in B_1, \dots, \xi_{i_N} \in B_N) = \prod_{n=1}^N \mathbb{P}(\xi_n \in B_n).$$

This definition can be rephrased in terms of σ -algebras as follows. The σ -algebras \mathcal{A}_i , $i \in I$, are *independent* if for all choices of distinct indices $i_1, \dots, i_N \in I$ and sets $A_1 \in \mathcal{A}_{i_1}, \dots, A_N \in \mathcal{A}_{i_N}$ we have

$$\mathbb{P}(A_1 \cap \dots \cap A_N) = \prod_{n=1}^N \mathbb{P}(A_n).$$

With this terminology, the random variables ξ_i are independent if and only if the σ -algebras $\sigma(\xi_i)$ are independent.

Definition E.1.9. The distribution of an E -valued random variable ξ is the Borel probability measure μ_ξ on E defined by

$$\mu_\xi(B) := \mathbb{P}(\xi \in B).$$

If ξ_n is a random variable in the metric space E_n for $n = 1, \dots, N$, then (ξ_1, \dots, ξ_N) is a random variable in $E_1 \times \dots \times E_N$ and we have the following criterion for independence:

Proposition E.1.10. The following conditions are equivalent:

- (1) the random variables ξ_1, \dots, ξ_N are independent;
- (2) we have the coincidence of distributions

$$\mu_{(\xi_1, \dots, \xi_N)} = \mu_{\xi_1} \times \dots \times \mu_{\xi_N};$$

- (3) we have

$$\mathbb{E}[f_1(\xi_1) \cdots f_n(\xi_N)] = \mathbb{E}f_1(\xi_1) \cdots \mathbb{E}f_N(\xi_N)$$

for all $f_n \in C_b(E_n)$, $n = 1, \dots, N$.

Proof. (1) \Rightarrow (3): By definition, ξ_1, \dots, ξ_N are independent if and only if property (3) holds for all f_n of the form $f_n = \mathbf{1}_{B_n}$, where B_n is any Borel set of E_n . By linearity with respect to each component, this implies the same property for all simple Borel functions $f_n : E_n \rightarrow \mathbb{K}$. Since any $f_n \in C_b(E_n)$ is a pointwise limit of a bounded sequence of such functions, property (3) follows from independence by dominated convergence.

(3) \Rightarrow (2): Suppose that $C_n \subseteq E_n$ are closed sets, and let

$$f_{n,k}(x) := (1 - k \cdot \text{dist}(x, E_n))_+.$$

Then $0 \leq f_{n,k} \leq 1$ and $f_{n,k} \rightarrow \mathbf{1}_{E_n}$ as $k \rightarrow \infty$. Hence

$$\begin{aligned} \mathbb{E}[\mathbf{1}_{C_1}(\xi_1) \cdots \mathbf{1}_{C_N}(\xi_N)] &= \lim_{k \rightarrow \infty} \mathbb{E}[f_{1,k}(\xi_1) \cdots f_{N,k}(\xi_N)] \\ &= \lim_{k \rightarrow \infty} \mathbb{E}f_{1,k}(\xi_1) \cdots f_{N,k}(\xi_N) = \mathbb{E}\mathbf{1}_{C_1}(\xi_1) \cdots \mathbb{E}\mathbf{1}_{C_N}(\xi_N) \end{aligned}$$

by dominated convergence, and this shows that $\mu_{(\xi_1, \dots, \xi_N)}$ and $\mu_{\xi_1} \times \cdots \times \mu_{\xi_N}$ agree on the collection \mathcal{C} all products $C_1 \times \cdots \times C_N$ of closed sets $C_n \subseteq E_n$. Since this collection contains $E_1 \times \cdots \times E_N$, is closed under finite intersections, and generates the Borel σ -algebra of $E_1 \times \cdots \times E_N$, it follows Dynkin's Lemma A.1.3 that the said measures are equal.

(2) \Rightarrow (1): This is obvious, since the definition of independence is simply the coincidence of the two measures on all products $B_1 \times \cdots \times B_N$ of Borel sets $B_n \subseteq E_n$. \square

Remark E.1.11. Suppose $\xi_n : \Omega \rightarrow E_n$, $n = 1, \dots, N$, are independent random variables. Let $\tilde{\Omega} := \Omega_1 \times \cdots \times \Omega_N$, where each Ω_n a copy of Ω . Define the random variables $\tilde{\xi}_n : \tilde{\Omega} \rightarrow E_n$ by

$$\tilde{\xi}_n(\omega_1, \dots, \omega_N) := \xi_n(\omega_n).$$

The random variables (ξ_1, \dots, ξ_N) and $(\tilde{\xi}_1, \dots, \tilde{\xi}_N)$ are identically distributed and the random variables $\tilde{\xi}_1, \dots, \tilde{\xi}_N$ are independent. Since most computations only involve the (joint) distributions of the ξ_n one may just as well work with the $\tilde{\xi}_n$ instead of the ξ_n . This has the advantage that the Fubini theorem can be used without any problems. We shall frequently refer to this construction in an informal way by stating that

“independent random variables ξ_1, \dots, ξ_N may assumed to be defined on distinct probability spaces $\Omega_1, \dots, \Omega_N$ ”.

We record a simple application of Proposition E.1.10.

Proposition E.1.12. *If $\lim_{n \rightarrow \infty} \xi_n = \xi$ and $\lim_{n \rightarrow \infty} \eta_n = \eta$ in probability in E and F , respectively, and if for each $n \geq 1$ the random variables ξ_n and η_n are independent, then ξ and η are independent.*

Proof. The assumptions imply that $\xi_n \rightarrow \xi$ and $\eta_n \rightarrow \eta$ in distribution and that $\lim_{n \rightarrow \infty} (\xi_n, \eta_n) \rightarrow (\xi, \eta)$ in probability, and therefore $\lim_{n \rightarrow \infty} (\xi_n, \eta_n) \rightarrow (\xi, \eta)$ in distribution by Proposition E.1.5.

For all $f \in C_b(E)$ and $g \in C_b(F)$ we have, $[(x, y) \mapsto f(x)g(y)] \in C_b(E \times F)$, and hence using Proposition E.1.10 and the assumptions,

$$\mathbb{E}[f(\xi)g(\eta)] = \lim_{n \rightarrow \infty} \mathbb{E}[f(\xi_n)g(\eta_n)] = \lim_{n \rightarrow \infty} \mathbb{E}f(\xi_n)\mathbb{E}g(\eta_n) = \mathbb{E}f(\xi)\mathbb{E}g(\eta).$$

By another application of Proposition E.1.10, this proves the independence of ξ and η . \square

E.1.c Characteristic functions

Let X be a Banach space. Recall from Section 1.1 that $\sigma(X^*)$ denote the σ -algebra in X generated by X^* . If X is separable, this σ -algebra coincides with the Borel σ -algebra of X (Proposition 1.1.1), but in general it may be coarser (cf. Example 1.4.3).

Definition E.1.13. *The characteristic function of a probability measure μ on $(X, \sigma(X^*))$ is the function $\widehat{\mu} : X^* \rightarrow \mathbb{C}$ defined by*

$$\widehat{\mu}(x^*) := \int_X \exp(i\Re\langle x, x^* \rangle) d\mu(x).$$

Note that if ξ is an X -valued random variable, then the characteristic function of its distribution is given by

$$\widehat{\mu_\xi}(x^*) = \mathbb{E}(\exp(i\Re\langle \xi, x^* \rangle)).$$

Our aim is to prove that the mapping $\mu \mapsto \widehat{\mu}$ is injective. We will prove this first for $X = \mathbb{R}^d$ and deduce the general case from this special case. When applied to the distributions of two X -valued random variables ξ_1 and ξ_2 , it will follow that $\xi_1 = \xi_2$ almost surely if they have the same characteristic function.

Theorem E.1.14 (Uniqueness of the characteristic function on \mathbb{R}^d).

Let λ_1 and λ_2 be Borel probability measures on \mathbb{R}^d whose characteristic functions are equal:

$$\widehat{\lambda}_1(\xi) = \widehat{\lambda}_2(\xi), \quad \xi \in \mathbb{R}^d.$$

Then $\lambda_1 = \lambda_2$.

Proof. By a standard approximation argument it suffices to prove that

$$\int_{\mathbb{R}^d} f d\lambda_1 = \int_{\mathbb{R}^d} f d\lambda_2, \quad f \in C_c(\mathbb{R}^d), \quad (\text{E.1})$$

where $C_c(\mathbb{R}^d)$ denote the space of all compactly supported continuous functions on \mathbb{R}^d .

Let $0 < \varepsilon < 1$ be arbitrary and fix $f \in C_c(\mathbb{R}^d)$. We may assume that $\|f\|_\infty \leq 1$. Let $r > 0$ be so large that the support of f is contained in an open cube $(-r, r)^d$ satisfying $\lambda_j(\mathbb{C}(-r, r)^d) \leq \varepsilon$ for $j = 1, 2$. By the Stone-Weierstrass theorem there exists a trigonometric polynomial $p : \mathbb{R}^d \rightarrow \mathbb{C}$ of period $2r$ such that $\sup_{x \in [-r, r]^d} |f(x) - p(x)| \leq \varepsilon$. Then, noting that $\|p\|_\infty \leq 1 + \varepsilon$,

$$\begin{aligned} \left| \int_{\mathbb{R}^d} f d\lambda_1 - \int_{\mathbb{R}^d} f d\lambda_2 \right| &\leq 2\varepsilon + \left| \int_{[-r, r]^d} f d\lambda_1 - \int_{[-r, r]^d} f d\lambda_2 \right| \\ &\leq 4\varepsilon + \left| \int_{[-r, r]^d} p d\lambda_1 - \int_{[-r, r]^d} p d\lambda_2 \right| \end{aligned}$$

$$\begin{aligned} &\leq 4\varepsilon + 2\varepsilon(1 + \varepsilon) + \left| \int_{\mathbb{R}^d} p \, d\lambda_1 - \int_{\mathbb{R}^d} p \, d\lambda_2 \right| \\ &= 4\varepsilon + 2\varepsilon(1 + \varepsilon). \end{aligned}$$

The last equality follows from the equality of the characteristic functions of λ_1 and λ_2 . Since $\varepsilon > 0$ was arbitrary, this proves (E.1). \square

In order to extend Theorem E.1.14 to arbitrary (real or complex) Banach spaces we need a lemma which enables us to reduce the complex case to the real case.

As a preliminary remark we recall that if X is a complex Banach space, then by restricting the scalar multiplication $(c, x) \mapsto cx$ to the real scalars we obtain a real Banach space which we shall denote by $X_{\mathbb{R}}$. As sets we have $X = X_{\mathbb{R}}$. A vector $x \in X$, when viewed as an element of $X_{\mathbb{R}}$, will be denoted by $x_{\mathbb{R}}$. By X^* and $X_{\mathbb{R}}^*$ we denote the (complex) dual of X and the (real) dual of $X_{\mathbb{R}}$, respectively.

Lemma E.1.15. *Let X be a complex Banach space. For all $x_{\mathbb{R}}^* \in X_{\mathbb{R}}^*$ there exists a unique $x^* \in X^*$ such that for all $x \in X$ we have*

$$\langle x_{\mathbb{R}}, x_{\mathbb{R}}^* \rangle = \Re \langle x, x^* \rangle.$$

Conversely, for all $x^ \in X^*$ the mapping $x_{\mathbb{R}} \mapsto \Re \langle x, x^* \rangle$ defines an element of $X_{\mathbb{R}}^*$. The induced mappings $X_{\mathbb{R}}^* \rightarrow X^*$ and $X^* \rightarrow X_{\mathbb{R}}^*$ are inverse to each other. Under the identifications $X_{\mathbb{R}} = X$ and $X_{\mathbb{R}}^* = X^*$ we have $\sigma(X^*) = \sigma(X_{\mathbb{R}}^*)$.*

Proof. Given a functional $x_{\mathbb{R}}^* \in X_{\mathbb{R}}^*$, define the mapping $x^* : X \rightarrow \mathbb{C}$ by

$$x^*(x) := \langle x_{\mathbb{R}}, x_{\mathbb{R}}^* \rangle - i \langle (ix)_{\mathbb{R}}, x_{\mathbb{R}}^* \rangle.$$

Then x^* is bounded and \mathbb{C} -linear, since

$$\begin{aligned} x^*(ix) &= \langle (ix)_{\mathbb{R}}, x_{\mathbb{R}}^* \rangle - i \langle (-x)_{\mathbb{R}}, x_{\mathbb{R}}^* \rangle = \langle (ix)_{\mathbb{R}}, x_{\mathbb{R}}^* \rangle + i \langle x_{\mathbb{R}}, x_{\mathbb{R}}^* \rangle \\ &= i(-i \langle (ix)_{\mathbb{R}}, x_{\mathbb{R}}^* \rangle + \langle x_{\mathbb{R}}, x_{\mathbb{R}}^* \rangle) = ix^*(x). \end{aligned}$$

Moreover, $\Re x^*(x) = \langle x_{\mathbb{R}}, x_{\mathbb{R}}^* \rangle$. This proves existence. To prove uniqueness, suppose that $\Re \langle x, x^* \rangle = 0$ for all $x \in X$. Then also $\Im \langle x, x^* \rangle = \Re \langle -ix, x^* \rangle = 0$, and therefore $\langle x, x^* \rangle = 0$ for all $x \in X$. It follows that $x^* = 0$. The converse assertion is obvious.

That the induced mappings $X_{\mathbb{R}}^* \rightarrow X^*$ and $X^* \rightarrow X_{\mathbb{R}}^*$ are inverse to each other is immediate from their definitions.

It remains to prove the identity $\sigma(X^*) = \sigma(X_{\mathbb{R}}^*)$. The inclusion ‘ \subseteq ’ follows by noting that for all $x^* \in X^*$,

$$\{\Re x^* \in [a, b], \Im x^* \in [c, d]\} = \{\Re x^* \in [a, b], -\Re ix^* \in [c, d]\}$$

and the fact that the rectangles $\{z \in \mathbb{C} : \Re z \in [a, b], \Im z \in [c, d]\}$ generate the Borel σ -algebra of \mathbb{C} . The inclusion ‘ \supseteq ’ follows by noting that for all $x_{\mathbb{R}}^* \in X_{\mathbb{R}}^*$ we have

$$\{x_{\mathbb{R}}^* \in [a, b]\} = \{\Re x^* \in [a, b]\},$$

where $x^* \in X^*$ is as in the first part of the proof. \square

Theorem E.1.16 (Uniqueness of the characteristic function on X). *Let μ_1 and μ_2 be probability measures on $(X, \sigma(X^*))$ whose characteristic functions are equal:*

$$\widehat{\mu}_1(x^*) = \widehat{\mu}_2(x^*), \quad x^* \in X^*.$$

Then $\mu_1 = \mu_2$.

Proof. By Lemma E.1.15 it suffices to prove the theorem for real Banach spaces X .

Let μ be probability measure on $(X, \sigma(X^*))$. For fixed $x_1^*, \dots, x_d^* \in X^*$ consider the map $T : X \rightarrow \mathbb{R}^d$, $x \mapsto (\langle x, x_1^* \rangle, \dots, \langle x, x_d^* \rangle)$. For all $t = (t_1, \dots, t_d) \in \mathbb{R}^d$,

$$\widehat{\mu}\left(\sum_{j=1}^d t_j x_j^*\right) = \int_{\mathbb{R}^d} \exp(i\langle t, Tx \rangle) d\mu(x) = \int_{\mathbb{R}^d} \exp(i\langle t, s \rangle) d(T\mu)(s) = \widehat{T\mu}(t),$$

where $T\mu$ denotes the image measure of μ under T .

Applying this to μ_1 and μ_2 it follows that $\widehat{T\mu}_1(t) = \widehat{T\mu}_2(t)$ for all $t \in \mathbb{R}^d$. By Theorem E.1.14, $T\mu_1 = T\mu_2$. As a result, μ_1 and μ_2 agree on the collection \mathcal{C} of all sets in X of the form

$$\{x \in X : (\langle x, x_1^* \rangle, \dots, \langle x, x_d^* \rangle) \in B\}$$

with $d \geq 1$, $x_1^*, \dots, x_d^* \in X^*$ and $B \in \mathcal{B}(\mathbb{R}^d)$. The family \mathcal{C} is closed under finite intersections and generates the σ -algebra $\sigma(X^*)$. Therefore, μ_1 and μ_2 agree on $\sigma(X^*)$ by Dynkin's Lemma A.1.3. \square

Corollary E.1.17. *If ξ_1 and ξ_2 are X -valued random variables whose distributions have the same characteristic function, then their distributions are equal.*

Proof. By strong measurability, ξ_1 and ξ_2 take values in some closed separable subspace X_0 of X almost surely. By the Hahn-Banach theorem the distributions μ_{ξ_1} and μ_{ξ_2} , viewed as Borel measures on X_0 , have the same characteristic functions.

We may therefore assume that X is separable. Since $\sigma(X^*) = \mathcal{B}(X)$ in that case, it follows from Theorem E.1.16 that $\mu_{\xi_1} = \mu_{\xi_2}$. \square

E.2 Gaussian variables

A unified treatment of real and complex standard Gaussian variables could be based on the central limit theorem which will be presented in the Theorem E.2.15: if $(\varepsilon_n)_{n \geq 1}$ is a Rademacher sequence with values in \mathbb{K} , then the limit

$$\gamma := \lim_{N \rightarrow \infty} \frac{1}{\sqrt{N}} \sum_{n=1}^N \varepsilon_n$$

exists in distribution and defines a *standard Gaussian variable* with values in \mathbb{K} . We take a more pedestrian approach here; it will be shown below that it leads to the same definitions.

Definition E.2.1 (Real Gaussian variables). *A real-valued random variable γ is called real Gaussian if, for some $\sigma \geq 0$, its distribution has density*

$$f_\sigma(t) = \frac{1}{\sqrt{2\pi\sigma^2}} \exp(-t^2/2\sigma^2)$$

with respect to the Lebesgue measure on \mathbb{R} .

The degenerate case $\sigma = 0$ corresponds to the random variable which takes the value 0 almost surely; this interpretation is justified by the observation that $\lim_{\sigma \downarrow 0} \int f_\sigma(t) dt = \delta_0$ weakly, with δ_0 the Dirac measure at 0.

A real-valued Gaussian variable satisfies

$$\mathbb{E}\gamma = 0, \quad \mathbb{E}|\gamma|^2 = \sigma^2.$$

The number σ^2 is called the *variance* of γ . A real Gaussian variable with variance $\sigma^2 = 1$ is called a *standard real Gaussian variable*.

The substitution $x^2/2\sigma^2 = y$ shows that if γ is real Gaussian with $\sigma > 0$, then for all $0 < p < \infty$ we have

$$\mathbb{E}|\gamma|^p = \frac{1}{\sqrt{2\pi}} \int_{\mathbb{R}} |x|^p e^{-x^2/2} dx = \frac{2^{p/2}\sigma^p}{\sqrt{\pi}} \Gamma((p+1)/2), \quad (\text{E.2})$$

where $\Gamma(x) = \int_0^\infty t^{x-1} e^{-t} dt$ is the Euler gamma function.

Proposition E.2.2. *A real-valued random variable γ is real Gaussian, with variance σ^2 , if and only if its characteristic function is given by*

$$\mathbb{E} \exp(i\xi\gamma) = \exp(-\frac{1}{2}\sigma^2\xi^2), \quad \xi \in \mathbb{R}.$$

Proof. The ‘only if’ statement is clear for $\sigma = 0$, and for $\sigma > 0$ it follows by completing the squares and Cauchy’s theorem to shift the path of integration:

$$\begin{aligned} \mathbb{E} \exp(i\xi\gamma) &= \frac{1}{\sqrt{2\pi}} \int_{-\infty}^{\infty} \exp(it\xi - t^2/2\sigma^2) dt \\ &= \frac{1}{\sqrt{2\pi}} \int_{-\infty}^{\infty} \exp(-\frac{1}{2}[(t/\sigma - i\sigma\xi)^2 + \sigma^2\xi^2]) dt \\ &= \exp(-\frac{1}{2}\sigma^2\xi^2) \cdot \frac{1}{\sqrt{2\pi}} \int_{\mathbb{R}-i\sigma\xi} \exp(-\frac{1}{2}z^2) dz \quad (\text{E.3}) \\ &= \exp(-\frac{1}{2}\sigma^2\xi^2) \cdot \frac{1}{\sqrt{2\pi}} \int_{\mathbb{R}} \exp(-\frac{1}{2}z^2) dz \\ &= \exp(-\frac{1}{2}\sigma^2\xi^2). \end{aligned}$$

The ‘if’ part then follows from Theorem E.1.14. □

Definition E.2.3 (Complex Gaussian variables). A complex-valued random variable γ is called complex Gaussian if, for some $\sigma \geq 0$, its distribution has density

$$f_\gamma(z) = \frac{1}{\pi\sigma^2} \exp(-|z|^2/\sigma^2)$$

with respect to the Lebesgue measure on \mathbb{C} . If $\sigma = 1$, then γ is called a standard complex Gaussian variable.

The same conventions hold with regard to the degenerate case $\sigma = 0$. As in the real case, a complex Gaussian variable satisfies

$$\mathbb{E}\gamma = 0, \quad \mathbb{E}|\gamma|^2 = \sigma^2.$$

The number σ^2 is again called the *variance* of γ . More generally, for $0 < p < \infty$ and $\sigma > 0$, using polar coordinates and substituting $r^2/\sigma^2 = y$ we compute:

$$\begin{aligned} \mathbb{E}|\gamma|^p &= \frac{1}{\pi\sigma^2} \int_{\mathbb{C}} |z|^p \exp(-|z|^2/\sigma^2) dz \\ &= \frac{2}{\sigma^2} \int_0^\infty r^{p+1} \exp(-r^2/\sigma^2) dr \\ &= \sigma^p \int_0^\infty y^{p/2} \exp(-y) dy = \sigma^p \Gamma(p/2 + 1). \end{aligned} \tag{E.4}$$

Proposition E.2.4. If γ_1 and γ_2 are independent standard real Gaussians with variance σ^2 , then

$$\gamma := \frac{1}{\sqrt{2}}(\gamma_1 + i\gamma_2)$$

is a standard complex Gaussian with variance σ^2 . Conversely, if γ is a complex Gaussian with variance σ^2 , then its real and imaginary parts are independent real-valued Gaussians with variance $\frac{1}{2}\sigma^2$.

Proof. We compute

$$\begin{aligned} &\mathbb{P}(\Re\gamma \in [a, b], \Im\gamma \in [c, d]) \\ &= \mathbb{P}(\gamma_1 \in [a\sqrt{2}, b\sqrt{2}]) \cdot \mathbb{P}(\gamma_2 \in [c\sqrt{2}, d\sqrt{2}]) \\ &= \frac{1}{\sqrt{2\pi\sigma^2}} \int_{a\sqrt{2}}^{b\sqrt{2}} \exp(-s^2/2\sigma^2) ds \cdot \frac{1}{\sqrt{2\pi\sigma^2}} \int_{c\sqrt{2}}^{d\sqrt{2}} \exp(-t^2/2\sigma^2) dt \\ &= \frac{1}{2\pi\sigma^2} \int_{a\sqrt{2}}^{b\sqrt{2}} \int_{c\sqrt{2}}^{d\sqrt{2}} \exp(-(s^2 + t^2)/2\sigma^2) dt ds \\ &= \frac{1}{\pi\sigma^2} \int_a^b \int_c^d \exp(-(s^2 + t^2)/\sigma^2) dt ds. \end{aligned}$$

This shows that the distribution of γ agrees with that of a complex Gaussian with variance σ^2 on all rectangles $\{\Re z \in [a, b], \Im z \in [c, d]\}$, and the claim follows. The converse statement follows by reversing the above computation.

□

Corollary E.2.5. *A complex-valued random variable γ is complex Gaussian, with variance σ^2 , if and only if its characteristic function is given by*

$$\mathbb{E} \exp(i\Re(\xi\gamma)) = \exp(-\frac{1}{4}\sigma^2|\xi|^2), \quad \xi \in \mathbb{C}.$$

Proof. If γ is complex Gaussian, it follows from the previous results that

$$\begin{aligned} \mathbb{E} \exp(i\Re(\xi\gamma)) &\stackrel{\xi=a+ib}{=} \mathbb{E} \exp(i(a\Re\gamma - b\Im\gamma)) \\ &= \mathbb{E} \exp(ia\Re\gamma) \mathbb{E} \exp(-ib\Im\gamma) \\ &= \exp(-a^2\sigma^2/4) \exp(-b^2\sigma^2/4) \\ &= \exp(-\frac{1}{4}|\xi|^2\sigma^2). \end{aligned} \tag{E.5}$$

The converse follows from Theorem E.1.16. □

Definition E.2.6 (Gaussian random variables). *A \mathbb{K} -valued random variable is Gaussian if it is \mathbb{K} -Gaussian, i.e., real Gaussian in case $\mathbb{K} = \mathbb{R}$ and complex Gaussian in case $\mathbb{K} = \mathbb{C}$.*

This definition is in line with various other notions that depend on the choice of scalar field, such as symmetric random variables (Definition 6.1.4) and Rademacher variables (Definition 6.1.6). The next proposition connects these notions:

Lemma E.2.7. *If γ is Gaussian, then γ is symmetric, and $\gamma/|\gamma|$ is a Rademacher variable if $\sigma > 0$.*

Proof. In the real case this is obvious. In the complex case it follows from

$$\begin{aligned} \mathbb{P}(\arg(\gamma/|\gamma|) \in [a, b]) &= \frac{1}{\pi\sigma^2} \int_0^\infty \int_a^b \exp(-|r|^2/\sigma^2) r \, d\theta \, dr \\ &= \frac{b-a}{\pi\sigma^2} \int_0^\infty \exp(-|r|^2/\sigma^2) r \, dr = \frac{b-a}{2\pi} \end{aligned}$$

that $\gamma/|\gamma|$ is uniformly distributed on the unit circle. □

E.2.a Multivariate Gaussian variables

Definition E.2.8. *An \mathbb{K}^n -valued random variable $\gamma = (\gamma_1, \dots, \gamma_n)$ is called Gaussian if $\langle c, \gamma \rangle := \sum_{k=1}^n c_k \gamma_k$ is Gaussian for all $c = (c_1, \dots, c_n) \in \mathbb{K}^n$.*

In particular this definition implies that the coordinate variables γ_k are Gaussian (take $c = e_k$, the k -th standard unit vector in \mathbb{K}^n). The converse is false: there exist examples of scalar Gaussian random variables $\gamma_1, \dots, \gamma_n$ for which $\gamma = (\gamma_1, \dots, \gamma_n)$ is *not* Gaussian. A simple example is given by $\gamma = (\gamma_1, \varepsilon\gamma_1)$ where ε is a Rademacher random variable which is independent of scalar Gaussian random variable γ_1 .

Definition E.2.9. The covariance matrix $Q = (q_{jk})_{j,k=1}^n$ of a Gaussian random variable γ is defined by

$$q_{jk} = \mathbb{E}\gamma_j\bar{\gamma}_k, \quad j, k = 1, \dots, n.$$

The matrix Q is positive (i.e., $(Q\xi|\xi) \geq 0$ for all $\xi \in \mathbb{K}^n$) and symmetric (i.e., $q_{jk} = \bar{q}_{kj}$ for all $j, k = 1, \dots, n$). Positivity follows from

$$(Q\xi|\xi) = \sum_{j,k=1}^n q_{jk}\xi_j\bar{\xi}_k = \mathbb{E}\left|\sum_{k=1}^n \xi_k\gamma_k\right|^2$$

and symmetry is evident. We call γ a *standard* Gaussian random variable if it has covariance matrix $Q = I$ (the identity matrix).

The characteristic function of a Gaussian random variable γ with covariance matrix Q is given by

$$\mathbb{E}(\exp(i\langle\gamma, \xi\rangle)) = \exp(-\tfrac{1}{2}(Q\xi|\xi)), \quad \xi \in \mathbb{R}^n$$

if the scalar field is real, and by

$$\mathbb{E}(\exp(i\Re\langle\gamma, \xi\rangle)) = \exp(-\tfrac{1}{4}(Q\xi|\xi)), \quad \xi \in \mathbb{C}^n$$

if the scalar field is complex. This follows from (E.3) and (E.5), observing that the Gaussian random variable $\langle\gamma, \xi\rangle$ has variance

$$\mathbb{E}|\langle\gamma, \xi\rangle|^2 = \mathbb{E}\sum_{j,k=1}^n \xi_j\bar{\xi}_k\gamma_j\bar{\gamma}_k = \sum_{j,k=1}^n q_{jk}\xi_j\bar{\xi}_k = (Q\xi|\xi).$$

The converse also holds:

Theorem E.2.10. An \mathbb{R}^n -valued random variable γ is Gaussian if and only if its characteristic function has the form

$$\mathbb{E}(\exp(i\langle\gamma, \xi\rangle)) = \exp(-\tfrac{1}{2}(Q\xi|\xi)), \quad \xi \in \mathbb{R}^n \quad (\text{E.6})$$

for some positive symmetric matrix Q with real coefficients. Similarly, a \mathbb{C}^n -valued random variable γ is Gaussian if and only if its characteristic function has the form

$$\mathbb{E}(\exp(i\Re\langle\gamma, \xi\rangle)) = \exp(-\tfrac{1}{4}(Q\xi|\xi)), \quad \xi \in \mathbb{C}^n$$

for some positive symmetric matrix Q with complex coefficients. In either case, γ is standard Gaussian if and only if $Q = I$.

Proof. It remains to prove the ‘if’ part. Let us prove this for real scalars; the proof for complex scalars is entirely similar.

Suppose that the characteristic function of γ has the indicated form. We have to check that for all $\xi \in \mathbb{R}^n$ the scalar random variable $\langle\gamma, \xi\rangle$ is Gaussian.

Applying (E.6) to the vectors $t\xi$ we see that the characteristic function of $\langle \gamma, \xi \rangle$ equals

$$\mathbb{E}(\exp(-it\langle \gamma, \xi \rangle)) = \exp(-\frac{1}{2}t^2(Q\xi|\xi)), \quad t \in \mathbb{R}.$$

Proposition E.2.2 implies that $\langle \gamma, \xi \rangle$ is Gaussian with variance $(Q\xi|\xi)$. \square

Corollary E.2.11. *Let $\gamma^{(1)}, \dots, \gamma^{(N)}$ be independent Gaussian random variables, with covariance matrices $Q^{(1)}, \dots, Q^{(N)}$. Then $\gamma := \sum_{k=1}^N \gamma^{(k)}$ is Gaussian, with covariance matrix $Q = \sum_{k=1}^N Q^{(k)}$.*

Proof. We consider the real case, the complex case being entirely similar. For all $\xi \in \mathbb{R}^n$ we have, by independence and (E.6),

$$\begin{aligned} \mathbb{E}(\exp(-i\langle \gamma, \xi \rangle)) &= \mathbb{E}\left(\prod_{k=1}^N \exp(-i\langle \gamma^{(k)}, \xi \rangle)\right) \\ &= \prod_{k=1}^N \mathbb{E}(\exp(-i\langle \gamma^{(k)}, \xi \rangle)) \\ &= \prod_{k=1}^N \exp\left(-\frac{1}{2}(Q^{(k)}\xi|\xi)\right) = \exp\left(-\frac{1}{2}(Q\xi|\xi)\right), \end{aligned}$$

where $Q = \sum_{k=1}^N Q^{(k)}$. Since every $Q^{(k)}$ is positive and symmetric, Q is positive and symmetric as well, and our claim follows from Theorem E.2.10. \square

As a special case note that if $\gamma_1, \dots, \gamma_n$ are independent scalar Gaussian random variables, then $\gamma := (\gamma_1, \dots, \gamma_n)$ is Gaussian. Indeed, we have

$$\gamma = \sum_{k=1}^n \gamma_k e_k,$$

where e_k denotes the k -th standard unit vector in \mathbb{K}^n . We then apply the above to the random variables $\gamma^{(k)} := \gamma_k e_k$.

Geometric interpretation of the covariance matrix

We continue with a geometric interpretation of the covariance matrix Q of a Gaussian random variable γ . Our starting point is the standard result from Linear Algebra that every positive symmetric matrix can be orthogonally diagonalised. Thus there exists an orthogonal basis $\{e_1, \dots, e_n\}$ of eigenvectors of Q , which we normalise to have unit length. Using this basis we can decompose γ as follows:

$$\gamma = \sum_{j=1}^n \langle \gamma, e_j \rangle e_j. \quad (\text{E.7})$$

Each random variable $\langle \gamma, e_j \rangle$ is Gaussian with variance

$$\mathbb{E}|\langle \gamma, e_j \rangle|^2 = (Qe_j|e_j) = \lambda_j(e_j|e_j) = \lambda_j,$$

where λ_j is the eigenvalue for e_j . We shall prove in a moment that the random variables $\langle \gamma, e_j \rangle$ are independent. Assuming this for the moment, we see that the components $\langle \gamma, e_j \rangle e_j$, which are Gaussian and take their values in the one-dimensional subspace spanned by e_j , are independent as well. Thus, every Gaussian random variable with values in \mathbb{K}^n can be represented as a sum of independent one-dimensional Gaussian random variables.

Note that in the decomposition (E.7) only the terms corresponding to strictly positive eigenvalues have an effective contribution. Indeed, if $\lambda_j = 0$ for some $1 \leq i \leq n$, then $\mathbb{E}|\langle \gamma, e_j \rangle|^2 = (Qe_j|e_j) = 0$, which implies that $\langle \gamma, e_j \rangle = 0$ almost surely. Let $J = \{j \in \{1, \dots, n\} : \lambda_j > 0\}$ and for $j \in J$ let $x_j := \sqrt{\lambda_j} e_j$. Then,

$$\gamma = \sum_{j \in J} \frac{1}{\lambda_j} \langle \gamma, x_j \rangle x_j = \sum_{j \in J} \gamma_j x_j,$$

where the variables $\gamma_j := \frac{1}{\lambda_j} \langle \gamma, x_j \rangle$ are independent and standard Gaussian.

To prove that the $\langle \gamma, e_j \rangle$ are independent we first show that they are *uncorrelated*, i.e., that

$$\mathbb{E}\langle \gamma, e_j \rangle \overline{\langle \gamma, e_k \rangle} = 0, \quad 1 \leq j \neq k \leq n.$$

We use a trick which is known as *polarisation*. On the one hand we have

$$\begin{aligned} (Q(e_j + e_k)|e_j + e_k) &= \mathbb{E}|\langle \gamma, e_j + e_k \rangle|^2 \\ &= \mathbb{E}|\langle \gamma, e_j \rangle|^2 + 2\Re\mathbb{E}\langle \gamma, e_j \rangle \overline{\langle \gamma, e_k \rangle} + \mathbb{E}|\langle \gamma, e_k \rangle|^2 \\ &= (Qe_j|e_j) + 2\Re\mathbb{E}\langle \gamma, e_j \rangle \overline{\langle \gamma, e_k \rangle} + (Qe_k|e_k) \end{aligned}$$

and on the other hand,

$$\begin{aligned} (e_j + e_k|e_j + e_k) &= (Qe_j|e_j) + (Qe_j|e_k) + (Qe_k|e_j) + (Qe_k|e_k) \\ &= (Qe_j|e_j) + 2\Re(Qe_j|e_k) + (Qe_k|e_k), \end{aligned}$$

where in the last step we used the symmetry of Q . Combining these identities and recalling that e_j and e_k are orthonormal eigenvectors, we obtain, for $j \neq k$,

$$\Re\mathbb{E}\langle \gamma, e_j \rangle \overline{\langle \gamma, e_k \rangle} = \Re(Qe_j|e_k) = \Re\lambda_j(e_j|e_k) = 0.$$

Repeating this argument with $e_j + e_k$ replaced by $ie_j + e_k$, we find that also $\Im\mathbb{E}\langle \gamma, e_j \rangle \overline{\langle \gamma, e_k \rangle} = 0$. This proves the claim.

Proposition E.2.12. *Let $\gamma = (\gamma_1, \dots, \gamma_n)$ be a Gaussian random variable. The components $\gamma_1, \dots, \gamma_n$ are independent if and only if they are uncorrelated.*

Proof. The ‘only if’ part being clear, we prove the ‘if’ part. We consider the real case, the complex case being entirely similar.

If the Gaussian variables $\gamma_1, \dots, \gamma_n$ are uncorrelated, then the covariance matrix of $\gamma = (\gamma_1, \dots, \gamma_n)$ is diagonal: $Q = \text{diag}(s_1, \dots, s_n)$ with $s_k = \mathbb{E}|\gamma_k|^2$. Then the characteristic function of γ is given by

$$\begin{aligned} \mathbb{E}(\exp(-i\langle \gamma, \xi \rangle)) &= \exp(-\tfrac{1}{2}(Q\xi|\xi)) = \exp\left(-\tfrac{1}{2} \sum_{k=1}^n s_k |\xi_k|^2\right) \\ &= \prod_{k=1}^n \exp(-\tfrac{1}{2} s_k |\xi_k|^2) = \prod_{k=1}^n \mathbb{E}(\exp(-i\xi_k \gamma_k)). \end{aligned}$$

The right-hand side is the characteristic function of $\tilde{\gamma} := (\tilde{\gamma}_1, \dots, \tilde{\gamma}_n)$, where the $\tilde{\gamma}_k$ are independent random variables, with each $\tilde{\gamma}_k$ distributed like the γ_k of the same index. By the uniqueness of the characteristic function (Corollary E.1.17), this shows that γ and $\tilde{\gamma}$ have the same distribution, and therefore the components of γ are independent, since those of $\tilde{\gamma}$ are. \square

E.2.b The central limit theorem

The central limit theorem is the statement that suitably normalised sums of independent random variables converge in distribution to a Gaussian random variable. In order to prove this, it is convenient to begin with some generalities on convergence of probability measures.

Definition E.2.13. *A sequence of Borel probability measures $(\mu_n)_{n \geq 1}$ on E converges weakly to the Borel probability measure μ on E if for all $f \in C_b(E)$ we have*

$$\lim_{n \rightarrow \infty} \int_E f \, d\mu_n = \int_E f \, d\mu.$$

Thus, $\lim_{n \rightarrow \infty} \xi_n = \xi$ in distribution if and only if $\lim_{n \rightarrow \infty} \mu_{\xi_n} = \mu_\xi$ weakly.

For Borel probability measures on \mathbb{R}^d or \mathbb{C}^d we have the following convenient criterion for weak convergence in terms of their characteristic functions (see Section E.1.c), due to Lévy.

Theorem E.2.14 (Lévy). *A sequence $(\mu_n)_{n \geq 1}$ of Borel probability measures on \mathbb{K}^d converges weakly to a Borel probability measure μ on \mathbb{K}^d if and only if their characteristic functions satisfy $\lim_{n \rightarrow \infty} \hat{\mu}_n(\xi) = \hat{\mu}(\xi)$ for all $\xi \in \mathbb{K}^d$.*

Proof. We only prove the ‘if’ part, the ‘only if’ part being clear.

Real case – Step 1 – By the continuity of $\hat{\mu}$ at 0 we can find $\delta > 0$ so small that

$$|\hat{\mu}(\xi) - 1| < \varepsilon, \quad \xi \in D := [-\delta, \delta]^d.$$

Write $|D| := (2\delta)^d$ for the Lebesgue measure of D . Define $K := [-2\delta^{-1}, 2\delta^{-1}]^d$. If $x = (x_1, \dots, x_d) \in \mathbb{C}K$, then at least one of its coordinates satisfies $|x_k| > 2\delta^{-1}$. Then,

$$\prod_{j=1}^n \left| \frac{\sin \delta x_j}{\delta x_j} \right| \leq \left| \frac{\sin \delta x_k}{\delta x_k} \right| < \frac{1}{2}.$$

Next, note that for all $x \in \mathbb{R}^d$ we have

$$\frac{1}{|D|} \int_D \exp(i\langle x, \xi \rangle) d\xi = \prod_{j=1}^d \frac{1}{2\delta} \int_{-\delta}^{\delta} e^{ix_j \xi_j} d\xi_j = \prod_{j=1}^d \frac{\sin \delta x_j}{\delta x_j}.$$

It follows that the integral on the left-hand side is a real number in the interval $[-1, 1]$, and by the previous estimate this number belongs to the interval $[-\frac{1}{2}, \frac{1}{2}]$ when $x \in \mathbb{C}K$. Thus for all $n \geq 1$ we have

$$\begin{aligned} \frac{1}{|D|} \int_D (1 - \widehat{\mu}_n(\xi)) d\xi &= \frac{1}{|D|} \int_D \int_{\mathbb{R}^d} (1 - \exp(i\langle x, \xi \rangle)) d\mu_n(x) d\xi \\ &= \int_{\mathbb{R}^d} \left(1 - \frac{1}{|D|} \int_D \exp(i\langle x, \xi \rangle) d\xi \right) d\mu_n(x) \\ &\geq \int_{\mathbb{C}K} \left(1 - \frac{1}{|D|} \int_D \exp(i\langle x, \xi \rangle) d\xi \right) d\mu_n(x) \\ &\geq \frac{1}{2} \mu_n(\mathbb{C}K). \end{aligned}$$

On the other hand, by the dominated convergence theorem,

$$\lim_{n \rightarrow \infty} \frac{1}{|D|} \int_D |1 - \widehat{\mu}_n(\xi)| d\xi = \frac{1}{|D|} \int_D |1 - \widehat{\mu}(\xi)| d\xi < \varepsilon.$$

Combining these estimates, we obtain that $\limsup_{n \rightarrow \infty} \mu_n(\mathbb{C}K) < 2\varepsilon$. Replacing K by a larger cube, we may also assume that $\mu(\mathbb{C}(-r, r)^d) < 2\varepsilon$.

Real case - Step 2 - Fix a function $f \in C_b(\mathbb{R}^d)$; we must prove that $\lim_{n \rightarrow \infty} \int_{\mathbb{R}^d} f d\mu_n = \int_{\mathbb{R}^d} f d\mu$. We may assume that $\|f\|_\infty \leq 1$.

By the Stone-Weierstrass theorem there exists a trigonometric polynomial $p : \mathbb{R}^d \rightarrow \mathbb{C}$ of period ℓ , where ℓ is the side-length of K , such that $\sup_{x \in K} |f(x) - p(x)| < \varepsilon$. Then, noting that $\|p\|_\infty < 1 + \varepsilon$, for all large enough n we have

$$\begin{aligned} \left| \int_{\mathbb{R}^d} f d\mu_n - \int_{\mathbb{R}^d} f d\mu \right| &< 4\varepsilon + \left| \int_K f d\mu_n - \int_{[-r, r]^d} f d\mu \right| \\ &< 6\varepsilon + \left| \int_K p d\mu_n - \int_{[-r, r]^d} p d\mu \right| \\ &< 6\varepsilon + 4\varepsilon(1 + \varepsilon) + \left| \int_{\mathbb{R}^d} p d\mu_n - \int_{\mathbb{R}^d} p d\mu \right|. \end{aligned}$$

The assumption on the convergence of the characteristic functions therefore implies that

$$\limsup_{n \rightarrow \infty} \left| \int_{\mathbb{R}^d} f \, d\mu_n - \int_{\mathbb{R}^d} f \, d\mu \right| < 6\varepsilon + 4\varepsilon(1 + \varepsilon).$$

Since $\varepsilon > 0$ was arbitrary, this completes the proof in the case $\mathbb{K}^d = \mathbb{R}^d$.

Complex case – To prove the result in the case $\mathbb{K}^d = \mathbb{C}^d$ let $T : \mathbb{C}^d \rightarrow \mathbb{R}^{2d}$ be defined by $T(x + iy) = (x, -y)$ where $x, y \in \mathbb{R}^d$. Let $\nu_n = T\mu_n$ and $\nu = T\mu$ denote the image measures. Then for $\xi = \eta + i\zeta$ with $\eta, \zeta \in \mathbb{R}^d$ one can check that $\widehat{\nu}_n(\eta, \zeta) = \widehat{\mu}_n(\xi)$ and $\widehat{\nu}(\eta, \zeta) = \widehat{\mu}(\xi)$. Therefore, by the result for \mathbb{R}^{2d} we find that $\nu_n \rightarrow \nu$ weakly, and from this we see that $\mu_n \rightarrow \mu$ weakly. \square

An \mathbb{R}^d -valued random variable ξ is called *symmetric* if ξ and $-\xi$ are identically distributed.

Theorem E.2.15 (Central limit theorem, real case). *Let $(\xi_n)_{n \geq 1}$ be a sequence of independent, identically distributed, and square integrable \mathbb{R}^d -valued random variables and let $q_{jk} = \mathbb{E}(\xi_{n,j}\xi_{n,k})$ and $\mathbb{E}\xi_n = 0$. Then*

$$\lim_{N \rightarrow \infty} \frac{1}{\sqrt{N}} \sum_{n=1}^N \xi_n = \gamma$$

in distribution, where γ is an \mathbb{R}^d -valued Gaussian random variable with covariance matrix $Q = (q_{jk})$.

Proof. We shall verify the conditions of Lévy’s theorem for the random variables $\gamma_N = \frac{1}{\sqrt{N}} \sum_{n=1}^N \xi_n$. Let μ_N denote the distribution of γ_N . We proceed in two steps.

Step 1 – First we consider the case $d = 1$. Moreover, by scaling we may assume $\mathbb{E}(\xi_n^2) = q_{11} = 1$. Let μ denote that common distribution of each ξ_n . Then by the dominated convergence theorem, $\widehat{\mu} : \mathbb{R} \rightarrow \mathbb{C}$ is twice continuously differentiable and $\widehat{\mu}(0) = 1$, $\widehat{\mu}'(0) = i\mathbb{E}(\xi) = 0$ and $\widehat{\mu}''(0) = -\mathbb{E}(\xi^2) = -1$. Hence, by Taylor’s theorem $\widehat{\mu}(t) = 1 - \frac{t^2}{2} + o(t^2)$. Therefore, by independence and elementary calculus,

$$\begin{aligned} \lim_{N \rightarrow \infty} \widehat{\mu}_N(s) &= \lim_{N \rightarrow \infty} \prod_{n=1}^N \mathbb{E} \exp\left(\frac{is\xi_n}{\sqrt{N}}\right) = \lim_{N \rightarrow \infty} \prod_{n=1}^N \widehat{\mu}\left(\frac{s}{\sqrt{N}}\right) = \\ &= \lim_{N \rightarrow \infty} \left[1 - \frac{s^2}{2N} + o\left(\frac{s}{N}\right)\right]^N = \exp\left(-\frac{1}{2}s^2\right) \end{aligned}$$

and the result follows since $\exp(-\frac{1}{2}s^2)$ is the characteristic function of the standard Gaussian measure.

Step 2 – The general case is reduced to the case $d = 1$ by observing that by Theorem E.2.14 a sequence of \mathbb{R}^d -valued random variables η_N converges in distribution to η if and only if for all $s \in \mathbb{R}^d \setminus \{0\}$ we have $\lim_{N \rightarrow \infty} \langle \eta_N, s \rangle = \langle \eta, s \rangle$ in distribution. Now applying this with γ_N , we see that it suffices to show $\lim_{N \rightarrow \infty} \langle \gamma_N, s \rangle \rightarrow \langle \gamma, s \rangle$ in distribution. Since

$$\langle \gamma_N, s \rangle = \frac{1}{\sqrt{N}} \sum_{n=1}^N \langle \xi_n, s \rangle,$$

the result follows since the real-valued random variables $\langle \xi_n, s \rangle$ are centred and $\mathbb{E}|\langle \xi_n, s \rangle|^2 = (Qs|s) = \mathbb{E}|\langle \gamma, s \rangle|^2$. \square

If γ_1 and γ_2 are two independent standard real-valued Gaussian random variables and $a, b \in \mathbb{R}$, then $a\gamma_1 + bi\gamma_2$ is a complex Gaussian random variable if and only if $a = b$. For this reason the complex version of the central limit theorem has an additional condition on the ξ_n .

Theorem E.2.16 (Central limit theorem, complex case). *Let $(\xi_n)_{n \geq 1}$ be a sequence of independent, identically distributed, and square integrable \mathbb{C}^d -valued random variables such that and let $q_{jk} = \mathbb{E}(\xi_{n,j} \overline{\xi_{n,k}})$ and $\mathbb{E}\xi_n = 0$. Assume that for all $n \geq 1$ and all $j, k \leq d$,*

- (1) $\Re(\xi_{n,j})$ and $\Im(\xi_{n,j})$ are identically distributed;
- (2) $\mathbb{E}(\Re(\xi_{nj})\Im(\xi_{nj})) = 0$.

Then

$$\lim_{N \rightarrow \infty} \frac{1}{\sqrt{N}} \sum_{n=1}^N \xi_n = \gamma$$

in distribution, where γ is an \mathbb{R}^d -valued Gaussian random variable with covariance matrix $Q = (q_{jk})$.

The additional condition is satisfied for complex Rademacher random variables.

Proof. The proof is the same as in Step 2 of the \mathbb{R}^d case. This time one has $\mathbb{E}\Re(\langle \xi_n, s \rangle)^2 = (Qs|s) = \mathbb{E}\Re(\langle \gamma, s \rangle)^2$. \square

E.2.c The maximum of Gaussian variables

In this section we will prove some useful maximal inequalities for a sequence of independent real Gaussian random variables which will be needed mostly to construct various counterexamples. Similar maximal estimates for complex Gaussians can be easily deduced from them.

We begin with some elementary one-sided inequality tail estimates. Here the case of a standard complex Gaussian is much simpler. Using polar coordinates we obtain

$$\mathbb{P}(|\gamma| > x) = 2 \int_x^\infty r e^{-r^2} dr = e^{-x^2}, \quad x > 0. \tag{E.8}$$

Lemma E.2.17. *Let γ be a standard real Gaussian variable.*

(1) For all $x, y > 0$, we have

$$\mathbb{P}(\gamma > x + y) \leq e^{-y^2/2} \mathbb{P}(\gamma > x).$$

In particular, $\mathbb{P}(\gamma > x) \leq \frac{1}{2}e^{-x^2/2}$.

(2) For all $x \in \mathbb{R}$,

$$\mathbb{P}(\gamma > x) \geq \frac{1}{\sqrt{2\pi}} \frac{2e^{-x^2/2}}{x + (x^2 + 4)^{1/2}}.$$

Proof. (1): Using a substitution and $(t + y)^2 \geq t^2 + y^2$, we obtain

$$\begin{aligned} \mathbb{P}(\gamma > x + y) &= \frac{1}{\sqrt{2\pi}} \int_x^\infty e^{-(t+y)^2/2} dt \\ &\leq \frac{e^{-y^2/2}}{\sqrt{2\pi}} \int_x^\infty e^{-t^2/2} dt = e^{-y^2/2} \mathbb{P}(\gamma > x). \end{aligned}$$

Since $\mathbb{P}(\gamma > 0) = 1/2$, the other part follows as well.

(2): Let $h : \mathbb{R} \rightarrow \mathbb{R}$ be given by

$$h(x) = \sqrt{2\pi} \mathbb{P}(\gamma > x) - \frac{2e^{-x^2/2}}{x + (x^2 + 4)^{1/2}}.$$

We wish to show that h is non-negative on \mathbb{R} . $\lim_{x \rightarrow \infty} h(x) = 0$ it suffices to show that $h'(x) \leq 0$. It is elementary to check that

$$h'(x) = \frac{x(x^2 + 4)^{1/2} - x^2 - 2}{(x + (x^2 + 4)^{1/2})(x^2 + 4)^{1/2}} e^{-x^2/2},$$

and the result follows from $x(x^2 + 4)^{1/2} \leq x^2 + 2$. □

As an immediate consequence we deduce the following inequalities.

Lemma E.2.18. *Let γ be a standard real Gaussian variable.*

(1) For all $x, y > 0$, we have

$$\mathbb{P}(|\gamma| > x + y) \leq e^{-y^2/2} \mathbb{P}(|\gamma| > x).$$

In particular, $\mathbb{P}(|\gamma| > x) \leq e^{-x^2/2}$.

(2) For all $x > 0$,

$$\mathbb{P}(|\gamma| > x) \geq \sqrt{\frac{2}{\pi}} \frac{e^{-x^2/2}}{1 + x}.$$

(3) For all $x \geq \sqrt{3}$,

$$\mathbb{P}(|\gamma| > x) \geq e^{-x^2}.$$

Proof. By symmetry we have $\mathbb{P}(|\gamma| > x) = 2\mathbb{P}(\gamma > x)$ for all $x > 0$. Therefore, (1) is immediate from Lemma E.2.17(1). Similarly, (2) follows from Lemma E.2.17(2) by noting that $x + (x^2 + 4)^{1/2} \leq 2(x + 1)$.

Concerning (3), by (2) it suffices to show that $\phi(x) := e^{x^2/2}/(1 + x) \geq \sqrt{\pi/2}$ for $x \geq \sqrt{3}$. We check that $\phi'(x) = e^{x^2/2}(x^2 + x - 1)/(x + 1)^2 \geq 0$ for $x \geq \frac{1}{2}(\sqrt{5} - 1)$, so in particular for $x \geq \sqrt{3} > \frac{1}{2}(\sqrt{5} - 1)$. Thus, we have $\phi(x) \geq \phi(\sqrt{3}) = e^{3/2}/(1 + \sqrt{3}) > \sqrt{\pi/2}$ for all $x \geq \sqrt{3}$, as required. \square

Lemma E.2.19. *Let $\xi_1, \dots, \xi_N : \Omega \rightarrow \mathbb{R}$ be independent real-valued random variables. Then for all $t \geq 0$ such that $\mathbb{P}(\xi_N^* \leq t) > 0$ one has*

$$\sum_{n=1}^N \mathbb{P}(\xi_n > t) \leq \frac{\mathbb{P}(\xi_N^* > t)}{\mathbb{P}(\xi_N^* \leq t)},$$

where $\xi_N^* = \max_{1 \leq n \leq N} |\xi_n|$.

Proof. Let $f(t) = \sum_{n=1}^N \mathbb{P}(\xi_n > t)$. Since $1 - x \leq e^{-x}$ for $x \geq 0$, we find that

$$\mathbb{P}(\xi_N^* \leq t) = \prod_{n=1}^N (1 - \mathbb{P}(|\xi_n| > t)) \leq e^{-f(t)}.$$

Moreover, as $1 - e^{-x} \geq xe^{-x}$ for $x \in \mathbb{R}$,

$$\mathbb{P}(\xi_N^* > t) \geq 1 - e^{-f(t)} \geq f(t)e^{-f(t)}.$$

The required estimate follows upon dividing both estimates. \square

Proposition E.2.20. *Let $(\gamma_n)_{n \geq 1}$ be a sequence of independent standard real Gaussian variables. For all $N \geq 1$ and real numbers x_1, \dots, x_N ,*

$$\mathbb{E} \max_{1 \leq n \leq N} |\gamma_n x_n| \geq \left(\frac{1}{5} \frac{\log N}{N} \sum_{n=1}^N x_n^2 \right)^{1/2}.$$

In particular,

$$\mathbb{E} \max_{1 \leq n \leq N} |\gamma_n| \geq \sqrt{\frac{1}{5} \log N}. \tag{E.9}$$

The constants in the above estimates are not optimal: in the proof below we actually prove a slightly sharper estimate.

Proof. It suffices to consider the case $N \geq 2$. By homogeneity we may assume that $\mathbb{E} \max_{1 \leq n \leq N} |\gamma_n x_n| = 1$ and $x_n > 0$ for all n . In view of $\mathbb{E}|\gamma| = \sqrt{2/\pi}$, this implies that $0 < x_n \leq \sqrt{\pi/2}$ for all n . Since $\mathbb{P}(\max_{1 \leq n \leq N} |\gamma_n x_n| > t) \leq 1/t$, it follows from Lemma E.2.19 that, for all $t > 1$,

$$\sum_{n=1}^N \mathbb{P}(|\gamma_n x_n| > t) \leq \frac{\mathbb{P}(\max_{1 \leq j \leq N} |\gamma_j x_j| > t)}{\mathbb{P}(\max_{1 \leq j \leq N} |\gamma_j x_j| \leq t)} \leq \frac{1}{t-1}.$$

By a direct computation of the second derivative, one verifies the convexity of the function $\Theta(y) := \mathbb{P}(|\gamma| > 1/\sqrt{y})$ for $y \in (0, \frac{1}{3}]$. Thus for $t \geq \sqrt{3\pi/2}$ we find, with $y_n := x_n/t$ (so that $y_n^2 \leq \frac{1}{3}$), we have

$$\Theta(s) := \Theta\left(\frac{1}{N} \sum_{n=1}^N y_n^2\right) \leq \frac{1}{N} \sum_{n=1}^N \Theta(y_n^2) \leq \frac{1}{N(t-1)}.$$

By Lemma E.2.18(3), with $z = 1/\sqrt{s} \geq \sqrt{3}$, we have

$$\Theta(s) = \mathbb{P}(|\gamma| > z) \geq e^{-z^2} = e^{-1/s}.$$

From the previous two estimates, we get

$$\frac{1}{N} \sum_{n=1}^N \frac{x_n^2}{t^2} = s \leq \frac{1}{\log(N(t-1))}.$$

Hence, with $t := \sqrt{3\pi/2}$ so that $t-1 \geq 1$, we have

$$\frac{2}{3\pi} \frac{\log N}{N} \sum_{n=1}^N x_n^2 \leq 1 = \left(\mathbb{E} \sup_{1 \leq n \leq N} |\gamma_n x_n|\right)^2,$$

and the result follows, since $2/3\pi > 1/5$. □

By Hölder’s inequality, (E.9) implies

$$\mathbb{E} \max_{1 \leq i \leq n} |\gamma_i|^p \geq \frac{1}{5^{p/2}} (\log(n))^{p/2}. \tag{E.10}$$

The next result shows that for $p = 2$ this estimate is optimal up to numerical constants. (The analogous estimate for other values of p can be deduced from the Kahane–Khintchine inequality 6.2.6 applied to the ℓ_N^∞ -valued Gaussian sum $\sum_{n=1}^N \gamma_n e_n$, where e_n are the standard unit vectors.)

Proposition E.2.21. *Let $(\gamma_n)_{n \geq 1}$ be a sequence of independent standard real Gaussian variables. For all $N \geq 1$,*

$$\mathbb{E}\left(\max_{1 \leq n \leq N} |\gamma_n|^2\right) \leq 2 \log(2N). \tag{E.11}$$

Proof. Let $\xi = \max_{n \leq N} |\gamma_n|$ and let $h : [0, \infty) \rightarrow [1, \infty)$ be given by $h(t) = \cosh(t^{1/2})$. It is easily checked that h is convex and strictly increasing, and from $h(t) \geq \frac{1}{2} \exp(t^{1/2})$ we see that the inverse function satisfies $h^{-1}(s) \leq \log(2s)^2$. Hence by Jensen’s inequality, for all $t > 0$ we have

$$\mathbb{E}\xi^2 = t^{-2}\mathbb{E}h^{-1}(\cosh(t\xi)) \leq t^{-2}h^{-1}(\mathbb{E}\cosh(t\xi)) \leq t^{-2}[\log(2\mathbb{E}\cosh(t\xi))]^2.$$

Moreover,

$$\mathbb{E}\cosh(t\xi) = \mathbb{E}\max_{n \leq N} \cosh(t\gamma_n) \leq \sum_{n=1}^N \mathbb{E}\cosh(t\gamma_n) \leq N\mathbb{E}\exp(t\gamma_1) = Ne^{t^2/2}.$$

Combining both estimates gives that $\mathbb{E}\xi^2 \leq (t^{-1} \log(2N) + t/2)^2$, and the lemma follows by taking $t = \sqrt{2 \log(2N)}$. \square

E.3 Notes

A general reference for the material presented in this appendix is [Kallenberg \[2002\]](#).

Section E.1

Thorough treatments of probability theory in metric spaces are presented in [Billingsley \[1999\]](#) and [Parthasarathy \[1967\]](#).

Section E.2

A survey on tail estimates for Gaussian distributions can be found in [Duembgen \[2010\]](#).

F

Banach lattices

Throughout this appendix we work over the real scalar field.

F.1 Definitions and basic properties

Definition F.1.1. A partially ordered real Banach space (X, \leq) is called a Banach lattice provided the following hold for all $x, y, z \in X$ and scalars $a \in \mathbb{R}$:

- (i) if $x \leq y$, then $x + z \leq y + z$;
- (ii) if $x \leq y$ and $c \geq 0$, then $cx \leq cy$;
- (iii) x and y have a least upper bound with respect to \leq ;
- (iv) if $0 \leq x \leq y$, then $\|x\| \leq \|y\|$.

The least upper bound of x and y is denoted by $x \vee y$. By definition, it has the property that whenever $x \leq z$ and $y \leq z$, then $x \vee y \leq z$; it is clear that there can be at most one such element. We can use (iii) to see that x and y also have a greatest lower bound, which is given by $x \wedge y = -((-x) \vee (-y))$. It is this is the unique element in X such that whenever $x \geq z$ and $y \geq z$, then $x \wedge y \geq z$.

An element $x \in X$ is called *positive* if $x \geq 0$. Every $x \in X$ admits a decomposition $x = x^+ - x^-$ with $x^+ := x \vee 0$ and $x^- := (-x) \vee 0$. The *modulus* of an element $x \in X$ is the positive element

$$|x| := x \vee (-x) = x^+ + x^-.$$

It satisfies

$$\||x|\| = \|x\|.$$

The dual X^* of any Banach lattice X is a Banach lattice with respect to the partial order obtained by declaring $x^* \leq y^*$ if $\langle x, x^* \rangle \leq \langle x, y^* \rangle$ for all $x \geq 0$.

Example F.1.2. The classical spaces $C(K)$, with K a compact Hausdorff space, and $L^p(S)$, with (S, \mathcal{A}, μ) a measure spaces and $1 \leq p \leq \infty$, are Banach lattices with respect to pointwise order, and so are the sequence spaces c_0 and ℓ^p , $1 \leq p \leq \infty$. In all these cases $x \vee y$ is given by taking pointwise maxima.

Let X and Y be Banach lattices.

Definition F.1.3. A bounded operator $T \in \mathcal{L}(X, Y)$ is said to be:

- positive, if $x \geq 0$ implies $Tx \geq 0$;
- a lattice homomorphism if $T(x_1 \vee x_2) = Tx_1 \vee Tx_2$ for all $x_1, x_2 \in X$.

We write $T \geq 0$ when T is positive. For such an operator we have $|Tx| \leq T|x|$ for all $x \in X$. Every lattice homomorphism is positive and satisfies $|Tx| = T|x|$ for all $x \in X$, and $x_1 \leq x_2$ implies $Tx_1 \leq Tx_2$.

The Banach lattices X and Y are said to be *lattice isomorphic* (*lattice isometric*) if there is a lattice homomorphism $T : X \rightarrow Y$ which is an isomorphism (isometric isomorphism). The following elementary fact will be used below: If $T : X \rightarrow Y$ is a lattice isomorphism, then T^{-1} is a lattice isomorphism as well.

F.2 The Krivine calculus

At various occasion throughout this volume it will be necessary to handle expressions such as

$$\left(\sum_{n=1}^N |x_n|^p \right)^{1/p}$$

for $x_1, \dots, x_N \in X$. In classical Banach lattices such as $C(K)$ and $L^p(\mu)$, such expressions are well defined in a pointwise sense. In a general Banach lattice, we use the fact that principal ideals are lattice isomorphic to $C(K)$ -spaces; in $C(K)$, the expressions can be defined in the pointwise sense. We shall explain this procedure, which is known as the *Krivine calculus* in more detail below. Readers who are unfamiliar with Banach lattices may skip this discussion and consider only the special case of Banach function spaces.

The Krivine calculus is based on the following version of Kakutani's representation theorem. For its statement we need the following terminology. An *ideal* in a Banach lattice X is a linear subspace I of X with the property that if $x \in I$ and $y \in X$ are such that $|y| \leq |x|$, then $y \in I$. An ideal is called a *principal ideal* if there exists an element $x \geq 0$ such that $I = I_x$, the smallest ideal in X containing x ; explicitly, $I_x = \{y \in X : \text{there exists } \lambda > 0 \text{ such that } |y| \leq \lambda|x|\}$. An element $x \geq 0$ is called an *order unit* of X if $I_x = X$.

Theorem F.2.1 (Kakutani). Let X be a Banach lattice. For $x \in X \setminus \{0\}$ put

$$I_x := \{y \in X : \text{there exists } \lambda \in (0, \infty) \text{ such that } |y| \leq \lambda|x|\}$$

and define, for $y \in I_x$,

$$\|y\|_{I_x} := \inf\{\lambda > 0 : |y| \leq \lambda|x|\}.$$

Then I_x is a Banach lattice. Moreover, there exists a compact Hausdorff space K such that I_x is lattice isometric to $C(K)$.

For the reader's convenience, we give a sketch of the proof.

Proof of Theorem F.2.1, sketch. Writing $I := I_x$ for brevity, we first show that $\|y\| \leq \|y\|_I$ for all $y \in I$. If $\lambda > 0$ is such that $|y| \leq \lambda|x|$, then $\|y\| \leq \lambda\|x\|$. Therefore, if we take the infimum over all such λ we obtain $\|y\| \leq \|y\|_I\|x\|$. It is clear that $\|x\|_I = 1$.

We first show that I is complete. Indeed, let $(y_n)_{n \geq 1}$ be a Cauchy sequence in I . The completeness of X together the above estimate implies that the sequence $(y_n)_{n \geq 1}$ converges to some $y \in X$. We claim that $y \in I$ and $\lim_{n \rightarrow \infty} y_n = y$ in I . Select a subsequence $(n_i)_{i \geq 1}$ such that $\|y_{n_{i+1}} - y_{n_i}\|_I < \frac{1}{2^i}$ for all $i \geq 1$. It follows that

$$|y_{n_{i+1}} - y_{n_i}| \leq \frac{1}{2^i}|x|.$$

Therefore, for all $l \geq k$,

$$|y_{n_{l+1}} - y_{n_k}| \leq \sum_{i=k}^l |y_{n_{i+1}} - y_{n_i}| \leq \sum_{i=k}^l \frac{1}{2^i}|x|.$$

Using that the modulus $|\cdot|$ is continuous with respect to the norm of X , it follows that upon letting $l \rightarrow \infty$ we find, for all $k \geq 1$,

$$|y - y_{n_k}| \leq \frac{1}{2^{k-1}}|x|.$$

This implies that

$$\|y - y_{n_k}\|_I \leq \frac{1}{2^{k-1}}.$$

Since $y_{n_k} \in I$, this shows that $y \in I$ and $\lim_{k \rightarrow \infty} y_{n_k} = y$ in I . By a standard argument this implies $y = \lim_{n \rightarrow \infty} y_n$ in I . This proves the completeness of I with respect to the norm $\|\cdot\|_I$.

For all $y, z \in I$, one shows next that $\|y \vee z\|_I = \|y\|_I \vee \|z\|_I$ and I has an order unit $|x|/\|x\|$. Banach lattices with this structure are known to be lattice isomorphic to a $C(K)$ -space. \square

Corollary F.2.2. *Let X be a Banach lattice, let $1 \leq p < \infty$ and $\frac{1}{p} + \frac{1}{p'} = 1$. The following assertions hold:*

(1) for each finite sequence $x_1, \dots, x_N \in X$, the set

$$A := \left\{ \sum_{n=1}^N a_n x_n : \left(\sum_{n=1}^N |a_n|^{p'} \right)^{1/p'} \leq 1 \right\}$$

has a least upper bound, which we denote $(\sum_{n=1}^N |x_n|^p)^{1/p} := \sup A$.

(2) if, for some $x \in X$, we have $x_1, \dots, x_N \in I_x$, then $(\sum_{n=1}^N |x_n|^p)^{1/p} \in I_x$.

(3) if $S : I_x \simeq C(K)$ is the lattice isometry provided by Kakutani's Theorem F.2.1, then

$$S \left(\sum_{n=1}^N |x_n|^p \right)^{1/p} = \left(\sum_{n=1}^N |Sx_n|^p \right)^{1/p}. \tag{F.1}$$

Proof. Let $x_1, \dots, x_N \in I_x$ for some $x \in X$. (Such elements always exist, for instance $x = \sum_{n=1}^N |x_n|$ will do). It is easy to check that the set A defined in (1) is contained in I_x . Set $f_n := Sx_n \in C(K)$, $n = 1, \dots, N$. The set

$$B := \left\{ \sum_{n=1}^N a_n f_n : \left(\sum_{n=1}^N |a_n|^{p'} \right)^{1/p'} \leq 1 \right\}$$

is bounded above in $C(K)$ and in fact we have $\sup B = (\sum_{n=1}^N |f_n|^p)^{1/p}$, where the right-hand side is defined in the pointwise sense. Let $f := \sup B$ denote this least upper bound. We claim that $y = S^{-1}f \in X$ is the least upper bound for A in X . This will show in particular that y does not depend on the choice of K and S .

Since S is a lattice isomorphism, for any $\sum_{n=1}^N a_n x_n \in A$ we have

$$\sum_{n=1}^N a_n x_n = S^{-1} \left(\sum_{n=1}^N a_n f_n \right) \leq S^{-1} f = y,$$

and therefore y is an upper bound for A . On the other hand, if $z \in X$ is any upper bound for A , then $g = Sz$ is an upper bound for B since S is a lattice isomorphism. Since f is the least upper bound for B , this implies $f \leq g$. Applying S^{-1} on both sides gives $y \leq z$. \square

F.3 Lorentz spaces

We begin by introducing a class of Banach lattices whose elements are functions on a given measure space and whose partial order is derived from the pointwise order.

Definition F.3.1. Let (S, \mathcal{A}, μ) be a measure space. A Banach function norm (over (S, \mathcal{A}, μ)) is a mapping $n : L^0(S) \rightarrow [0, \infty]$ that satisfies, for all $f, g \in L^0(S)$ and scalars $a \in \mathbb{R}$,

- (i) $n(f + g) \leq n(f) + n(g)$;
- (ii) $n(af) = an(f)$ for all scalars $a \geq 0$;
- (iii) $0 \leq f \leq g$ μ -almost everywhere implies $n(f) \leq n(g)$;
- (iv) $n(f) = 0$ if and only if $f = 0$ μ -almost everywhere.

Condition (iii) implies $n(f) = n(|f|)$ and therefore, for all $a \in \mathbb{R}$, $n(af) = n(|af|) = |a|n(|f|) = |a|n(f)$. It follows that $\|f\| := n(f)$ defines a norm on the real vector space

$$X = \{f \in L^0(S) : n(f) < \infty\},$$

which has the properties (i)–(iv) of Definition F.1.1. If X is complete (i.e., if X is a Banach space), then X is called a *Banach function space* (over (S, \mathcal{A}, μ)).

The familiar spaces $L^p(\mu)$ and ℓ^p , $1 \leq p \leq \infty$, and c_0 are Banach function spaces. The space $C[0, 1]$ is a Banach lattice, but not a Banach function space. Indeed, if $n : L^0(0, 1) \rightarrow [0, \infty]$ has the four properties listed above, then $n(\mathbf{1}) < \infty$ implies $n(\mathbf{1}_{[0, \frac{1}{2}]}) < \infty$, but $\mathbf{1}_{[0, \frac{1}{2}]}$ does not belong to $C[0, 1]$.

Let (S, \mathcal{A}, μ) be a measure space and $p, q \in (0, \infty]$.

Definition F.3.2. *The Lorentz space $L^{p,q}(S)$ is defined as the space of all measurable functions $f : S \rightarrow \mathbb{K}$ for which*

$$\|f\|_{L^{p,q}(S)} := \left\| t \mapsto t^{1/p} f^*(t) \right\|_{L^q(\mathbb{R}_+, \frac{dt}{t})}$$

is finite, where

$$f^*(t) := \inf\{\lambda > 0 : \mu(|f| > \lambda) \leq t\}, \quad t \in [0, \infty),$$

is the non-increasing rearrangement of f .

Example F.3.3. Let $f = \sum_{n=1}^N a_n \mathbf{1}_{A_n}$ be a μ -simple function, represented in such a way that $|a_1| \geq |a_2| \geq \dots \geq |a_N| > 0$ with A_1, \dots, A_N disjoint. For $p, q \in (0, \infty)$, the following holds:

$$\|f\|_{L^{p,q}(S)} = \left(\frac{p}{q} \sum_{n=1}^N |a_n|^q (t_n^{q/p} - t_{n-1}^{q/p}) \right)^{1/q}, \quad (\text{F.2})$$

where $t_0 := 0$ and $t_n := \sum_{i=1}^n \mu(A_i)$ for $n = 1, \dots, N$. This is a straightforward consequence of the identity $f^* = \sum_{n=1}^N |a_n| \mathbf{1}_{[t_{n-1}, t_n)}$.

It is elementary to check that $f^*(t) > r$ if and only if $\mu(|f| > r) > t$. This implies

$$\mu(|f| > r) = |\{f^* > r\}|, \quad r \in [0, \infty),$$

which shows that $|f|$ and f^* are identically distributed. In particular,

$$\|f\|_{L^p(S)} = \|f^*\|_{L^p(\mathbb{R}_+)} = \|f\|_{L^{p,p}(S)}, \quad p \in (0, \infty]. \quad (\text{F.3})$$

Lemma F.3.4. For all $0 < p \leq \infty$ and $0 < q < \infty$ the following identity for the Lorentz norm holds:

$$\|f\|_{L^{p,q}(S)} = p^{1/q} \|t \mapsto t(\mu(|f| > t))^{1/p}\|_{L^q(\mathbb{R}_+, \frac{dt}{t})}. \tag{F.4}$$

In the case $q = \infty$ the above definition of $L^{p,\infty}(S)$ coincides with the one of Section 2.2.b.

Proof. We first observe that $f^*(t) > r$ if and only if $\mu(|f| > r) > t$.

For $0 < q < \infty$, the identity follows by comparing the two iterated integrals of $r^{q-1}t^{q/p-1}$ over the subset $\{f^*(t) > r\} = \{\mu(|f| > r) > t\}$ of $(0, \infty) \times (0, \infty)$.

For $q = \infty$, let $r > 0$ and $0 < \varepsilon < \mu(|f| > r)$ be arbitrary. Taking $t = t_0 = \mu(|f| > r) - \varepsilon$ in the above observation gives $f^*(t_0) > r$. Therefore,

$$\|f\|_{L^{p,\infty}(S)} \geq t_0^{1/p} f^*(t_0) \geq t_0^{1/p} r = \left(\mu(|f| > r) - \varepsilon\right)^{1/p} r.$$

The inequality ‘ \geq ’ in (F.4) is obtained by first letting $\varepsilon \downarrow 0$ and then taking the supremum over $r > 0$. To prove the inequality ‘ \leq ’, let $t > 0$ and $0 < \varepsilon < f^*(t)$ be arbitrary. Setting $r_0 = f^*(t) - \varepsilon$ in the above observation gives $\mu(|f| > r_0) > t$. Thus

$$\sup_{r>0} r\mu(|f| > r)^{1/p} \geq r_0\mu(|f| > r_0)^{1/p} \geq r_0 t^{1/p} = (f^*(t) - \varepsilon)t^{1/p}.$$

First letting $\varepsilon \downarrow 0$ and then taking the supremum over all $t > 0$ gives the remaining estimate. □

The following identity for a μ -measurable function $f : S \rightarrow \mathbb{K}$ and $r > 0$ is simple to verify

$$\| |f|^r \|_{L^{p,q}(S)} = \|f\|_{L^{p,qr}(S)}^r. \tag{F.5}$$

The Lorentz spaces are ordered in the following way.

Lemma F.3.5. Let $p \in (0, \infty)$. For $0 < q < r \leq \infty$, we have $L^{p,q}(S) \hookrightarrow L^{p,r}(S)$ with constant $(q/p)^{(r-q)/qr}$.

Proof. We first consider the case $r = \infty$. Using that f^* is non-increasing we can estimate

$$\begin{aligned} t^{1/p} f^*(t) &= \left(\frac{q}{p} \int_0^t (s^{1/p} f^*(s))^q \frac{ds}{s}\right)^{1/q} \\ &\leq \left(\frac{q}{p} \int_0^t (s^{1/p} f^*(s))^q \frac{ds}{s}\right)^{1/q} \leq \left(\frac{q}{p}\right)^{1/q} \|f\|_{L^{p,q}(S)}. \end{aligned}$$

Taking the supremum over all $t > 0$, we find $\|f\|_{L^{p,\infty}(S)} \leq \left(\frac{q}{p}\right)^{1/q} \|f\|_{L^{p,q}(S)}$.

For $r < \infty$, using the previous case we find

$$\|f\|_{L^{p,r}(S)}^r = \int_0^\infty (s^{1/p} f^*(s))^{r-q+q} \frac{ds}{s}$$

$$\leq \|f\|_{L^{p,\infty}(S)}^{r-q} \|f\|_{L^{p,q}(S)}^q \leq \left(\frac{q}{p}\right)^{(r-q)/q} \|f\|_{L^{p,q}(S)}^r$$

and the result follows with constant $\left(\frac{q}{p}\right)^{(r-q)/qr}$. \square

Lemma F.3.6. *Let $p \in (1, \infty)$. For all $f \in L^1(S) \cap L^\infty(S)$,*

$$\|f\|_{L^{p,1}(S)} \leq p \|f\|_{L^1(S)}^{1/p} \|f\|_{L^\infty(S)}^{1/p'}.$$

Proof. By density it suffices to consider simple functions f . By homogeneity we may assume that $\|f\|_{L^\infty(S)} = 1$. If we let f be represented as in (F.2), then $a_1 = 1$. Put $s_n = t_n^{1/p}$ for $n = 0, \dots, N$ and $a_{N+1} := 0$. By a summation by parts and Jensen's inequality (applied with the probability measure $\nu(\{n\}) = |a_n| - |a_{n+1}|$ on $\{1, \dots, N\}$),

$$\begin{aligned} \|f\|_{L^{p,1}(S)} &= p \sum_{n=1}^N |a_n| (s_n - s_{n-1}) = p \sum_{n=1}^N (|a_n| - |a_{n+1}|) s_n \\ &\leq p \left(\sum_{n=1}^N (|a_n| - |a_{n+1}|) s_n^p \right)^{1/p} = p \left(\sum_{n=1}^N (|a_n| - |a_{n+1}|) t_n \right)^{1/p} \\ &= p \left(\sum_{n=1}^N |a_n| (t_n - t_{n-1}) \right)^{1/p} = p \|f\|_{L^1(S)}^{1/p}. \end{aligned}$$

\square

F.4 Notes

Standard references on the theory of Banach lattices include [Aliprantis and Burkinshaw \[2006\]](#), [Meyer-Nieberg \[1991\]](#), [Schaefer \[1974\]](#). An excellent exposition of the Krivine calculus is presented in [Lindenstrauss and Tzafriri \[1979\]](#). A complete proof of Kakutani's representation theorem [F.2.1](#) can be found in [Aliprantis and Burkinshaw \[2006, Theorems 4.21 and 4.29\]](#). Detailed accounts on Lorentz spaces can be found in [Grafakos \[2008\]](#), [Lindenstrauss and Tzafriri \[1979\]](#).

G

Semigroups of linear operators

G.1 Unbounded linear operators

By a *linear operator* in X we understand a pair $(A, D(A))$, where $D(A)$ is a linear subspace of X and $A : D(A) \rightarrow X$ is linear. If no confusion is likely to arise will just write A instead of $(A, D(A))$. The space $D(A)$ is referred to as the *domain* of A . The range and null space of A will be denoted by $R(A)$ and $N(A)$, respectively.

We begin our discussion with some generalities on spectra and resolvents of linear operators. The *resolvent set* $\rho(A)$ of a linear operator A on a Banach space X is the set of all $\lambda \in \mathbb{C}$ for which $\lambda - A$ has a two-sided bounded inverse. More precisely, there should exist a (necessarily unique) bounded linear operator B on X such that

- (i) $B(\lambda - A)x = x$ for all $x \in D(A)$;
- (ii) $Bx \in D(A)$ and $(\lambda - A)Bx = x$ for all $x \in X$.

In this situation we write $B =: R(\lambda, A) =: (\lambda - A)^{-1}$ and call this operator the *resolvent* of A at the point $\lambda \in \rho(A)$. The *spectrum* of A is the complement $\sigma(A) := \mathbb{C} \setminus \rho(A)$. We recall the *resolvent identity*

$$R(\lambda, A) - R(\mu, A) = (\mu - \lambda)R(\lambda, A)R(\mu, A), \quad \lambda, \mu \in \rho(A).$$

As in the case of a bounded operator one proves that $\rho(A)$ is an open set. More precisely:

Lemma G.1.1. *If $\lambda \in \rho(A)$, then $B(\lambda, r) \subseteq \rho(A)$ with $r = 1/\|R(\lambda, A)\|$. Moreover, if $|\lambda - \mu| \leq \delta r$ with $0 \leq \delta < 1$, then*

$$\|R(\mu, A)\| \leq \frac{\delta}{1 - \delta} \|R(\lambda, A)\|.$$

Proof. Set $B := \lambda - A$. If $T \in \mathcal{L}(X)$ has norm $\|T\| \leq \delta r$ with $0 \leq \delta < 1$ and $r = 1/\|B^{-1}\|$, then $\|B^{-1}T\| \leq \delta < 1$ and therefore the linear operator $B - T = B(I - B^{-1}T)$ is boundedly invertible. By the Neumann series,

$$\begin{aligned} \|(B - T)^{-1} - B^{-1}\| &\leq \|B^{-1}\| \|(I - B^{-1}T)^{-1} - I\| \\ &= \|B^{-1}\| \left\| \sum_{n \geq 1} (B^{-1}T)^n \right\| \leq \frac{1}{r} \frac{\delta}{1 - \delta}. \end{aligned}$$

Taking $T = (\lambda - \mu)I$ gives the result. \square

This lemma has a number of easy consequences we shall explore next.

Lemma G.1.2. *The function $\lambda \mapsto R(\lambda, A)$ is holomorphic on $\varrho(A)$.*

Proof. By letting $\delta \downarrow 0$, the estimate in the proof of the previous lemma shows that the function $\lambda \mapsto R(\lambda, A)$ is continuous on $\varrho(A)$. To prove its holomorphy, we use the resolvent identity and the continuity just proved to obtain

$$\lim_{\mu \rightarrow \lambda} \frac{R(\lambda, A) - R(\mu, A)}{\lambda - \mu} = - \lim_{\mu \rightarrow \lambda} R(\lambda, A)R(\mu, A) = -R(\lambda, A)^2.$$

\square

The norms of the resolvent operators blow up near the boundary of the resolvent set:

Lemma G.1.3. *If $\lambda_n \rightarrow \lambda$ in \mathbb{C} , with each $\lambda_n \in \varrho(A)$ and $\lambda \in \partial\varrho(A)$, then $\lim_{n \rightarrow \infty} \|R(\lambda_n, A)\| = \infty$.*

Proof. If not, then along a subsequence the norms of the resolvent operators $R(\lambda_{n_k}, A)$ would remain bounded, say by constant M . By the estimate of Lemma G.1.1, this would imply that the balls $B(\lambda_{n_k}, 1/M)$ are contained in $\varrho(A)$. For large k , however, these balls contain λ as an interior point, and this contradicts the assumption $\lambda \in \partial\varrho(A)$. \square

The following lemma will also be very useful.

Lemma G.1.4. *If the open half-line $(0, \infty)$ is contained in $\varrho(A)$ and*

$$\sup_{\lambda > 0} \|\lambda R(\lambda, A)\| =: M < \infty,$$

then $M \geq 1$, the open sector $\Sigma := \{\lambda \in \mathbb{C} : |\arg(\lambda)| < \arcsin(1/M)\}$ is contained in $\varrho(A)$, and

$$\sup_{\lambda \in \Sigma} \|\lambda R(\lambda, A)\| \leq \frac{M}{1 - M \arcsin(1/M)}.$$

The argument is always taken in the interval $(-\pi, \pi)$.

Proof. For $x \in D(A)$ we have $\lambda R(\lambda, A)x = x + R(\lambda, A)Ax \rightarrow x$ as $\lambda \rightarrow \infty$, from which it follows that $M \geq 1$.

Lemma G.1.1 shows that for each $\mu > 0$ the open ball with radius $1/\|R(\mu, A)\|$ is contained in $\varrho(A)$. The union of these balls is a sector; we shall now verify that the sine of its angle equals at least $1/M$.

Let $\varphi \in (0, \arcsin(1/M)) \subseteq (0, \frac{1}{2}\pi)$. Fix $\lambda \in \overline{\Sigma}_\varphi$ and let $\mu > 0$ be determined by the requirement that the triangle spanned by $0, \lambda, \mu$ has a right angle at λ (thus, by Pythagoras, $|\lambda - \mu|^2 + |\lambda|^2 = |\mu|^2$, so $\mu = -|\lambda|^2/\Re\lambda$). Let θ denote the angle of λ with the positive axis. See Figure G.1. Then

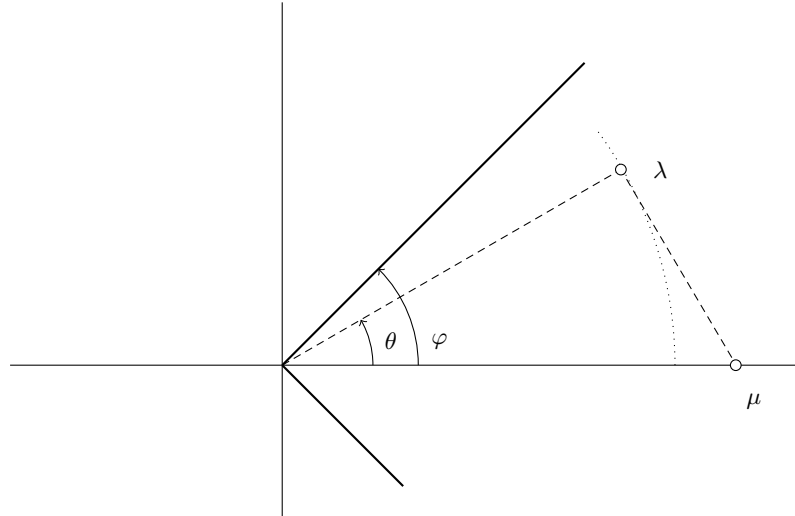

Fig. G.1: The proof of Lemma G.1.4

$|\lambda - \mu|/|\mu| = \sin \theta < \sin \varphi < 1/M$, so $|\lambda - \mu| < |\mu|/M \leq 1/\|R(\mu, A)\|$. Hence $\lambda \in \varrho(A)$ and by the estimate for the Neumann series in Lemma G.1.1

$$\begin{aligned} \|R(\lambda, A)\| &\leq \|R(\mu, A)\| \sum_{n=0}^{\infty} \frac{|\lambda - \mu|^n}{|\mu|^n} \|\mu R(\mu, A)\|^n \\ &\leq \frac{M}{|\mu|} \sum_{n=0}^{\infty} (\sin \varphi)^n M^n \leq \frac{M}{1 - M \sin \varphi} \cdot \frac{1}{|\lambda|}. \end{aligned}$$

□

Duality

Let X_1 and X_2 be Banach spaces and consider a linear operator $(A, D(A))$ acting from X_1 to X_2 . If A is *densely defined*, i.e., if $D(A)$ is dense, we may

define a linear operator $(A^*, D(A^*))$ from X_2^* to X_1^* in the following way. We define $D(A^*)$ to be the set of all $x_2^* \in X_2^*$ with the property that there exists an element $x_1^* \in X_1^*$ such that

$$\langle x, x_1^* \rangle = \langle Ax, x_2^* \rangle, \quad x \in D(A).$$

Since $D(A)$ is dense in X_1 , the element $x_1^* \in X_1^*$ (if it exists) is unique and we set

$$A^* x_2^* := x_1^*, \quad x_2^* \in D(A^*).$$

Definition G.1.5. *Let A be a densely defined linear operator. The operator A^* is called the adjoint of A .*

We recall that the weak*-topology of a dual Banach space X is the coarsest topology on X^* which renders the mappings $x^* \mapsto \langle x, x^* \rangle$ continuous. From this it is immediate that the annihilator of a non-empty subset V of X , i.e., the set

$$V^\perp := \{x^* \in X^* : \langle v, x^* \rangle = 0 \text{ for all } v \in V\}$$

is weak*-closed.

Proposition G.1.6. *Let X_1 and X_2 be Banach spaces and let A be a densely defined linear operator from X_1 to X_2 . The following assertions hold:*

- (1) *the adjoint A^* is weak*-closed from X_2^* to X_1^* , that is, the graph of A^* is weak*-closed in $X_2^* \times X_1^*$;*
- (2) *if A is also closed, then A^* is weak*-densely defined, i.e., the domain of A^* is weak*-dense in X_2^* .*

Proof. We start with the preliminary remark that if X and Y are Banach spaces, then the pairing

$$\langle (x, y), (x^*, y^*) \rangle := \langle x, x^* \rangle + \langle y, y^* \rangle$$

allows us to identify $X^* \times Y^*$ with the dual of $X \times Y$.

(1): Let $G(A^*) = \{(x_1^*, A^* x_1^*) : x_1^* \in D(A^*)\}$ be the graph of A^* in $X_2^* \times X_1^*$. By definition of $D(A^*)$ we have $(x_2^*, x_1^*) \in G(A^*)$ if and only if

$$\langle (-Ax_1, x_1), (x_2^*, x_1^*) \rangle = 0, \quad x_1 \in D(A).$$

In other words, $G(A^*)$ is the annihilator of $\rho(G(A))$, where $\rho : X_1 \times X_2 \rightarrow X_2 \times X_1$ is defined by $\rho(x_1, x_2) = (-x_2, x_1)$, and therefore $G(A^*)$ is weak*-closed. This proves that A^* is weak*-closed.

(2): Now assume that $(A, D(A))$ is also closed. We will show that $D(A^*)$ separates the points of X_2 . Suppose $x_2 \neq y_2$ in X_2 . Then $(0, x_2 - y_2)$ is a non-zero element of $X_1 \times X_2$ which does not belong to $G(A)$. Since $G(A)$ is closed, by the Hahn-Banach theorem there exists an element $(x_1^*, x_2^*) \in (G(A))^\perp$ such that

$$\langle (0, x_2 - y_2), (x_1^*, x_2^*) \rangle = \langle x_2 - y_2, x_2^* \rangle \neq 0.$$

To finish the proof we check that $x_2^* \in D(A^*)$. For all $x_1 \in D(A)$ we have $(x_1, Ax_1) \in G(A)$ and therefore

$$0 = \langle (x_1, Ax_1), (x_1^*, x_2^*) \rangle = \langle x_1, x_1^* \rangle + \langle Ax_1, x_2^* \rangle.$$

But this means that $x_2^* \in D(A^*)$ and $A^*x_2^* = -x_1^*$. \square

The following simple result ‘dualises’ the definition of $D(A^*)$.

Proposition G.1.7. *Let $(A, D(A))$ be a closed and densely defined linear operator from X_1 to X_2 . If $x_1 \in X_1$ and $x_2 \in X_2$ are such that $\langle x_2, x_2^* \rangle = \langle x_1, A^*x_2^* \rangle$ for all $x_2^* \in D(A^*)$, then $x_1 \in D(A)$ and $Ax_1 = x_2$.*

Proof. We must prove that $(x_1, x_2) \in G(A)$. Since $G(A)$ is closed in $X_1 \times X_2$, by the Hahn-Banach theorem it suffices to check that $\langle (x_1, x_2), (x_1^*, x_2^*) \rangle = 0$ for all $(x_1^*, x_2^*) \in (G(A))^\perp$.

Fix an arbitrary $(x_1^*, x_2^*) \in (G(A))^\perp$. As in the second part of the previous proof we have $x_2^* \in D(A^*)$ and $A^*x_2^* = -x_1^*$. Hence,

$$\langle (x_1, x_2), (x_1^*, x_2^*) \rangle = \langle x_1, -A^*x_2^* \rangle + \langle x_2, x_2^* \rangle = 0.$$

\square

G.2 C_0 -semigroups

Linear equations of mathematical physics can often be cast in the abstract form

$$\begin{cases} u'(t) = Gu(t), & t \in [0, T], \\ u(0) = x, \end{cases} \quad (\text{ACP})$$

where $(G, D(G))$ is a linear operator in some Banach space X . Typically, X is a Banach space of functions suited for the particular problem at hand and G is a partial differential operator. The abstract initial value problem (ACP) is referred to as the *abstract Cauchy problem* associated with G . A ‘solution’ of the problem (ACP) is a function $u : [0, T] \rightarrow X$ which satisfies the equation in some suitable sense. We will consider various solution concepts shortly.

Let us first take a look at the much simpler case where G is a bounded operator. In that case, the unique solution of (ACP) is given by

$$u(t) = e^{tG}u_0, \quad t \in [0, T],$$

where

$$e^{tG} := \sum_{n=0}^{\infty} \frac{1}{n!} t^n G^n.$$

The operators e^{tG} may be thought of as ‘solution operators’ mapping the initial value u_0 to the solution $e^{tG}u_0$ at time t . Clearly, $e^{0G} = I$, $e^{tG}e^{sG} = e^{(t+s)G}$, and $t \mapsto e^{tG}$ is continuous. We generalise these properties as follows.

Definition G.2.1. A family $S = \{S(t)\}_{t \geq 0}$ of bounded linear operators acting on a Banach space X is called a C_0 -semigroup if the following three properties are satisfied:

- (S1) $S(0) = I$;
- (S2) $S(t)S(s) = S(t+s)$ for all $t, s \geq 0$;
- (S3) $\lim_{t \downarrow 0} \|S(t)x - x\| = 0$ for all $x \in X$.

It is sometimes convenient to call a family of operators that satisfies (S1) and (S2) a semigroup. The third property is usually referred to as the strong continuity of the semigroup, and indeed the terms ‘ C_0 -semigroup’ and ‘strongly continuous semigroup’ are used synonymously in the literature.

The infinitesimal generator, or briefly the generator, of $(S(t))_{t \geq 0}$ is the linear operator $(G, D(G))$ defined by

$$D(G) := \{x \in X : \lim_{t \downarrow 0} \frac{1}{t}(S(t)x - x) \text{ exists in } X\},$$

$$Gx := \lim_{t \downarrow 0} \frac{1}{t}(S(t)x - x), \quad x \in D(G).$$

A C_0 -group (of operators) is defined similarly, by replacing the index set $\{t \geq 0\}$ by $\{t \in \mathbb{R}\}$.

We shall frequently use the trivial observation that if G generates the C_0 -semigroup $(S(t))_{t \geq 0}$, then $G - \mu$ generates the C_0 -semigroup $(e^{-\mu t} S(t))_{t \geq 0}$. The next two propositions collect some elementary properties of C_0 -semigroups and their generators.

Proposition G.2.2. Let $(S(t))_{t \geq 0}$ be a C_0 -semigroup on X . There exist constants $M \geq 1$ and $\omega \in \mathbb{R}$ such that $\|S(t)\| \leq M e^{\omega t}$ for all $t \geq 0$.

Proof. There exists a number $\delta > 0$ such that $\sup_{t \in [0, \delta]} \|S(t)\| =: \sigma < \infty$. Indeed, otherwise we could find a sequence $t_n \downarrow 0$ such that $\lim_{n \rightarrow \infty} \|S(t_n)\| = \infty$. By the uniform boundedness theorem, this implies the existence of an $x \in X$ such that $\sup_{n \geq 1} \|S(t_n)x\| = \infty$, contradicting the strong continuity assumption (S3). This proves the claim. By the semigroup property (S2), for $t \in [(k-1)\delta, k\delta]$ it follows that $\|S(t)\| \leq \sigma^k \leq \sigma^{1+t/\delta}$, where the second inequality uses that $\sigma \geq 1$ by (S1). This proves the proposition, with $M = \sigma$ and $\omega = (1/\delta) \log \sigma$. \square

Proposition G.2.3. Let $(S(t))_{t \geq 0}$ be a C_0 -semigroup on X with generator G . The following assertions hold:

- (1) for all $x \in X$ the orbit $t \mapsto S(t)x$ is continuous for $t \geq 0$;
- (2) for all $x \in D(G)$ and $t \geq 0$ we have $S(t)x \in D(G)$ and $GS(t)x = S(t)Gx$;
- (3) for all $x \in X$ we have $\int_0^t S(s)x \, ds \in D(G)$ and

$$G \int_0^t S(s)x \, ds = S(t)x - x,$$

- and if $x \in D(G)$, then both sides are equal to $\int_0^t S(s)Gx \, ds$;
- (4) the generator G is a closed and densely defined operator;
- (5) for all $x \in D(G)$ the orbit $t \mapsto S(t)x$ is continuously differentiable for $t \geq 0$ and

$$\frac{d}{dt}S(t)x = GS(t)x = S(t)Gx, \quad t \geq 0.$$

Proof. (1): The right continuity of $t \mapsto S(t)x$ follows from the right continuity at $t = 0$ (S3) and the semigroup property (S2). For the left continuity, observe that for $t \geq h \geq 0$,

$$\|S(t)x - S(t-h)x\| \leq \|S(t-h)\| \|S(h)x - x\| \leq \sup_{s \in [0,t]} \|S(s)\| \|S(h)x - x\|,$$

where the supremum is finite by Proposition G.2.2.

(2): By the semigroup property

$$\lim_{h \downarrow 0} \frac{1}{h} (S(h)S(t)x - S(t)x) = S(t) \lim_{h \downarrow 0} \frac{1}{h} (S(h)x - x) = S(t)Gx.$$

This shows that $S(t)x \in D(G)$ and $GS(t)x = S(t)Gx$.

(3): The first identity follows from

$$\begin{aligned} \lim_{h \downarrow 0} \frac{1}{h} (S(h) - I) \int_0^t S(s)x \, ds &= \lim_{h \downarrow 0} \frac{1}{h} \left(\int_0^t S(s+h)x \, ds - \int_0^t S(s)x \, ds \right) \\ &= \lim_{h \downarrow 0} \frac{1}{h} \left(\int_t^{t+h} S(s)x \, ds - \int_0^h S(s)x \, ds \right) \\ &= S(t)x - x, \end{aligned}$$

where we used the continuity of $t \mapsto S(t)x$. The identity for $x \in D(G)$ will follow from the second part of the proof of (4).

(4): Density of $D(G)$ follows from the first part of (3), since by (1) we have $\lim_{t \downarrow 0} \frac{1}{t} \int_0^t S(s)x \, ds = x$.

To prove that G is closed we must check that the graph $\mathbf{G}(G) = \{(x, Gx) : x \in D(G)\}$ is closed in $X \times X$. Suppose that $(x_n)_{n \geq 1}$ is a sequence in $D(G)$ such that $\lim_{n \rightarrow \infty} x_n = x$ and $\lim_{n \rightarrow \infty} Gx_n = y$ in X . Then

$$\begin{aligned} \frac{1}{h} (S(h)x - x) &= \lim_{n \rightarrow \infty} \frac{1}{h} (S(h)x_n - x_n) \\ &= \lim_{n \rightarrow \infty} \frac{1}{h} \int_0^h S(s)Gx_n \, ds = \frac{1}{h} \int_0^h S(s)y \, ds. \end{aligned}$$

Passing to the limit for $h \downarrow 0$, this gives $x \in D(G)$ and $Gx = y$. The above identities also prove the second part of (3).

(5): This follows from (1), (2), and the definition of G . \square

By considering repeated integrals, (3) self-improves to the assertion that $D(G^n)$ is dense for all $n \geq 1$.

As a first application let us prove that a C_0 -semigroup is determined by its generator. Suppose G generates the C_0 -semigroups $(S(t))_{t \geq 0}$ and $(T(t))_{t \geq 0}$. For $x \in D(G)$, differentiating the function $f : [0, t] \rightarrow X$, $f(s) := S(t-s)T(s)x$, with respect to s , we obtain $f'(s) = -GS(t-s)T(s)x + S(t-s)GT(s)x = 0$, and therefore f is constant. Hence $S(t)x = f(0) = f(t) = T(t)x$. Since this is true for all $x \in D(G)$, and $D(G)$ is dense in X , this proves the result.

For initial values $x \in D(G)$, Proposition G.2.3(5) proves that $t \mapsto u(t) = S(t)x$ is a *classical solution* in the sense that it belongs to $C([0, T]; D(G)) \cap C^1([0, T]; X)$ and solves the equation pointwise in $t \in [0, T]$. This classical solution is unique. Indeed, suppose $t \mapsto v(t)$ is another classical solution. The function $s \mapsto S(t-s)v(s)$ is continuous on $[0, t]$ and continuously differentiable on $(0, t)$, with derivative

$$\frac{d}{ds} S(t-s)v(s) = -GS(t-s)v(s) + S(t-s)v'(s) = 0$$

since $v'(t) = Gv(s)$. Thus, $s \mapsto S(t-s)v(s)$ is constant on every interval $[0, t]$. Since $v(0) = x$ it follows that $v(t) = S(t-t)v(t) = S(t-0)v(0) = S(t)x = u(t)$. This proves uniqueness. Hence if u is a classical solution, then the initial value x belongs to $D(G)$ and $u(t) = S(t)x$.

Although classical solutions exist only for initial values $x \in D(G)$, the mapping $u(t) := S(t)x$ is well defined for all $x \in X$ and may therefore be considered as a generalised solution to (ACP).

We have seen in Proposition G.2.3 that the generator of a C_0 -semigroup is always densely defined and closed. As a consequence, $D(G)$ is a Banach space with respect to its graph norm. In various applications it is of interest to know when a given dense subspace Y of X , contained in $D(G)$, is dense as a subspace of $D(G)$. If this is the case, Y is called a *core* for G . The next result gives a simple sufficient condition for this.

Proposition G.2.4. *Let $(S(t))_{t \geq 0}$ be a C_0 -semigroup with generator G . If Y is a linear subspace of $D(G)$ which is dense in Y and invariant under each operator $S(t)$, then Y is dense in $D(G)$.*

Proof. By the exponential boundedness of $(S(t))_{t \geq 0}$, upon replacing G by $G - \lambda$ for sufficiently large $\lambda > 0$ we may assume that $\lim_{n \rightarrow \infty} \|S(t)\| = 0$.

Fix $x \in D(G)$ and choose a sequence $(y_n)_{n \geq 1}$ in Y such that $\lim_{n \rightarrow \infty} y_n = Gx$ in X . Fix $t > 0$. Then

$$\lim_{n \rightarrow \infty} \int_0^t S(s)y_n ds = \int_0^t S(s)Gx ds = S(t)x - x$$

in X and

$$\lim_{n \rightarrow \infty} G \int_0^t S(s)y_n ds = \lim_{n \rightarrow \infty} S(t)y_n - y_n = S(t)Gx - Gx.$$

It follows that

$$\lim_{n \rightarrow \infty} \int_0^t S(s)y_n \, ds = S(t)x - x \text{ in } D(G).$$

Since the restriction of $(S(t))_{t \geq 0}$ to $D(G)$ is strongly continuous on $D(G)$ we may approximate the integrals by Riemann sums in the norm of $D(G)$. By the invariance of Y under $(S(t))_{t \geq 0}$, these Riemann sums belong to Y . It follows that for each $t > 0$ and $\varepsilon > 0$ there is a $y_{t,\varepsilon} \in Y$ such that

$$\|(S(t)x - x) - y_{t,\varepsilon}\|_{D(G)} < \varepsilon.$$

As $t \rightarrow \infty$, $\|S(t)x\|_{D(G)} = \|S(t)x\| + \|S(t)Gx\| \rightarrow 0$ and therefore, for large enough $t > 0$,

$$\|y_{t,\varepsilon} - x\|_{D(G)} \leq \varepsilon + \|S(t)x\|_{D(G)} < 2\varepsilon.$$

This shows that x can be approximated in $D(G)$ by elements of Y . □

We continue with two results which show that the semigroup property self-improves in several ways.

A family of bounded linear operators $(S(t))_{t \geq 0}$ on X is said to be a *weakly continuous semigroup* if (S1) and (S2) hold and for all $x \in X$ and $x^* \in X^*$ one has $\lim_{t \downarrow 0} \langle S(t)x, x^* \rangle = \langle x, x^* \rangle$.

Proposition G.2.5. *Every weakly continuous semigroup is strongly continuous.*

Proof. Suppose $(S(t))_{t \geq 0}$ is a weakly continuous semigroup on the Banach space X . Let

$$X_0 := \{x \in X : \lim_{t \downarrow 0} \|S(t)x - x\| = 0\}$$

be the subspace of all elements in X on which $(S(t))_{t \geq 0}$ acts in a strongly continuous way. We must show that $X_0 = X$.

Repeating the argument in the proof of Proposition G.2.2, $t \mapsto \|S(t)\|$ is bounded on some non-trivial interval $[0, \delta]$. By a standard $\varepsilon/3$ -argument, this implies that X_0 is a closed subspace of X . Also, by the semigroup property, it follows that $t \mapsto \|S(t)\|$ is bounded on every bounded sub-interval in $[0, \infty)$.

Next, because of its weak continuity at $t = 0$ combined with the semigroup property, the range of each orbit $t \mapsto S(t)x$ is weakly separable, hence separable by a corollary to the Hahn–Banach theorem. Again by the semigroup property, the orbits are also weakly right-continuous, hence weakly measurable. Therefore, by the Pettis measurability theorem, they are strongly measurable. In particular the Bochner integrals

$$y(t, x) := \frac{1}{t} \int_0^t S(r)x \, dr$$

exist for all $x \in X$ and $t > 0$. Fix $x \in X$ and $0 < t < 1$. For $0 < s < t$,

$$\begin{aligned}
\|S(s)y(t, x) - y(t, x)\| &= \frac{1}{t} \left\| \int_0^t S(s+r)x \, dr - \int_0^t S(r)x \, dr \right\| \\
&= \frac{1}{t} \left\| \int_t^{t+s} S(r)x \, dr - \int_0^s S(r)x \, dr \right\| \\
&\leq 2s \cdot \frac{1}{t} \left(\sup_{0 \leq r \leq 2} \|S(r)\| \right) \|x\|
\end{aligned}$$

shows that $y(t, x) \in X_0$. But then

$$\lim_{t \downarrow 0} \langle y(t, x), x^* \rangle = \lim_{t \downarrow 0} \frac{1}{t} \int_0^t \langle S(r)x, x^* \rangle \, dr = \langle x, x^* \rangle.$$

This shows that x belongs to the weak closure of X_0 , and hence to X_0 . \square

Corollary G.2.6. *Let $(S(t))_{t \geq 0}$ be a C_0 -semigroup on a Banach space X . If X is reflexive, then the family $(S^*(t))_{t \geq 0}$ of adjoint operators is a C_0 -semigroup on X^* .*

Proof. The only thing that needs attention is strong continuity. It is evident that $(S^*(t))_{t \geq 0}$ is weak*-continuous, and if X is reflexive this is the same thing as weakly continuous. Now the result follows from Proposition G.2.5. \square

A family of operators $(S(t))_{t \geq 0}$ on X is said to be *strongly measurable* if for all $x \in X$ the orbit $t \mapsto S(t)x$ is strongly measurable on $[0, \infty)$, and *strongly continuous for $t > 0$* (briefly, $C_{>0}$) if for all $x \in X$ the orbit $t \mapsto S(t)x$ is continuous for $t > 0$.

Proposition G.2.7. *Every strongly measurable semigroup of operators is $C_{>0}$.*

Proof. The proof is divided into two steps.

Step 1 – First we prove that $\|S(t)\|$ is bounded on each interval $[\alpha, \beta]$ with $0 < \alpha < \beta < \infty$. Assuming the contrary, let $0 < a < b < \infty$ be such that $\|S(t)\|$ is unbounded on $[a, b]$. By the uniform boundedness theorem there exists a sequence $(\xi_n) \subseteq [a, b]$ and an $x \in X$ of norm one such that $\xi_n \rightarrow \xi$ and $\|S(\xi_n)x\| > n$. On the other hand, because $t \mapsto \|S(t)x\|$ is measurable, there exists a constant M and a measurable subset $F \subseteq [0, \xi]$ of measure $|F| > \xi/2$ such that $\|S(t)x\| \leq M$ on F . The sets

$$E_n := \{\xi_n - t : t \in F \cap [0, \xi_n]\}$$

are measurable, and for n large enough we have $|E_n| > \xi/2$. For $t \in F \cap [0, \xi_n]$ we have

$$n \leq \|S(\xi_n)x\| \leq \|S(\xi_n - t)\| \|S(t)x\| \leq M \|S(\xi_n - t)\|$$

and therefore $\|S(\eta)\| \geq n/M$ for all $\eta \in E_n$. Let $E := \bigcap_n \bigcup_{k \geq n} E_k$. Since $\bigcup_{k \geq n} E_k \downarrow E$ and $|\bigcup_{k \geq n} E_k| \geq |E_n| \geq \xi/2 - |\xi_n - \xi|$, we have $|E| \geq \xi/2$. For $\eta \in E$ it follows that $\|S(\eta)\| = \infty$, a contradiction.

Step 2 – Fix $x \in X$ and $\xi > 0$ and choose numbers $0 < \alpha < \beta < \xi$. For all $\eta > 0$,

$$(\beta - \alpha) [S(\xi + \eta) - S(\xi)]x = \int_{\alpha}^{\beta} S(\tau)[S(\xi + \eta - \tau) - S(\xi - \tau)]x \, d\tau.$$

If $\|S(t)\| \leq M$ for all $t \in [\alpha, \beta]$, then the norm of the integrand does not exceed $M\| [S(\xi + \eta - \tau) - S(\xi - \tau)]x \|$, which is a measurable function of τ on $[\alpha, \beta]$. For $\eta \rightarrow 0$ this gives

$$(\beta - \alpha) \| (S(\xi + \eta) - S(\xi))x \| \leq M \int_{\xi - \beta}^{\xi - \alpha} \| S(\sigma + \eta)x - S(\sigma)x \| \, d\sigma \rightarrow 0,$$

the convergence being a consequence of the strong continuity of translations in $L^1(\mathbb{R}; X)$. \square

The adjoint semigroup

Let $(S(t))_{t \geq 0}$ be a C_0 -semigroup on X . The *adjoint semigroup* $(S^*(t))_{t \geq 0}$ consisting of the adjoint operators $S^*(t) := (S(t))^*$ generally fails to be strongly continuous. For example, the adjoint of the semigroup $(S(t))_{t \geq 0}$ of left-translations on $L^1(\mathbb{R})$ is the semigroup $(S^*(t))_{t \geq 0}$ of right-translations on $L^\infty(\mathbb{R})$, and for a given $f \in L^\infty(\mathbb{R})$ the mapping $t \mapsto S^*(t)f$ is continuous if and only if f is uniformly continuous. Replacing $L^1(\mathbb{R})$ by $C_0(\mathbb{R})$ and $L^\infty(\mathbb{R})$ by $M(\mathbb{R})$, the space of bounded Borel measures on \mathbb{R} , then for a given $\mu \in M(\mathbb{R})$ the mapping $t \mapsto S^*(t)\mu$ is continuous if and only if μ is absolutely continuous with respect to the Lebesgue measure.

These examples show that it is natural to define

$$X^\odot := \{x^* \in X^* : \lim_{t \downarrow 0} \|S^*(t)x^* - x^*\| = 0\}.$$

It follows trivially from this definition that X^\odot is $S^*(t)$ -invariant, i.e., for all $t \geq 0$ we have $S^*(t)X^\odot \subseteq X^\odot$. Also, since $S(t)$ is locally bounded, X^\odot is a closed subspace of X^* .

Proposition G.2.8. *The space X^\odot is a closed, weak*-dense, $S^*(t)$ -invariant linear subspace of X^* . Moreover $X^\odot = \overline{D(G^*)}$.*

Proof. We have already seen that X^\odot is closed and $S^*(t)$ -invariant. Weak*-density of X^\odot follows from the weak*-density of $D(G^*)$ and $X^\odot = \overline{D(G^*)}$, which will be proved next.

Let $x^* \in D(G^*)$. Dualising the identity of Proposition G.2.3(3),

$$\|S^*(t)x^* - x^*\| = \sup_{\|x\| \leq 1} \left| \int_0^t \langle x, S^*(s)G^*x^* \rangle \, ds \right| \leq t \left(\sup_{0 \leq s \leq t} \|S(s)\| \right) \|G^*x^*\|.$$

This shows that $D(G^*) \subseteq X^\odot$. Since X^\odot is closed, also the norm closure $\overline{D(G^*)}$ belongs to X^\odot .

For the converse inclusion let $x^\odot \in X^\odot$. Then

$$\left\| \frac{1}{t} \int_0^t S^*(s)x^\odot \, ds - x^\odot \right\| \leq \frac{1}{t} \int_0^t \|S^*(s)x^\odot - x^\odot\| \, ds \rightarrow 0 \quad \text{as } t \downarrow 0$$

since $x^\odot \in X^\odot$, the first integral being understood in the weak*-sense (cf. the discussion in Section 1.2.c). To complete the proof we will show that $\frac{1}{t} \int_0^t S^*(s)x^\odot \, ds \in D(G^*)$. For $x \in D(G)$ we have, again by dualising Proposition G.2.3(3),

$$\left\langle Gx, \int_0^t S^*(s)x^* \, ds \right\rangle = \langle x, S^*(t)x^* - x^* \rangle.$$

It follows that $\int_0^t S^*(s)x^* \, ds \in D(G^*)$ and $G^* \int_0^t S^*(s)x^* \, ds = S^*(t)x^* - x^*$. \square

Let $S^\odot(t)$ denote the restriction of $S^*(t)$ to the invariant subspace X^\odot . Since X^\odot is closed, X^\odot is a Banach space and it is clear from the definition of X^\odot that $S^\odot(t)$ is a strongly continuous semigroup on X^\odot . We will call $(S^\odot(t))_{t \geq 0}$ the *strongly continuous adjoint* of $(S(t))_{t \geq 0}$. Let its generator be G^\odot . The following proposition gives a precise description of G^\odot in terms of G^* .

If B is a linear operator on a Banach space Y and Z is a linear subspace of Y containing its domain $D(B)$, then the *part of B in Z* is the linear operator B_Z defined by

$$\begin{aligned} D(B_Z) &:= \{y \in D(B) : By \in Z\}, \\ B_Z y &:= By, \quad y \in D(B_Z). \end{aligned}$$

Proposition G.2.9. G^\odot is the part of G^* in X^\odot .

Proof. Let B be the part of G^* in X^\odot . If $x^\odot \in D(G^\odot)$, then

$$\lim_{t \downarrow 0} \frac{1}{t} (S^*(t)x^\odot - x^\odot) = \lim_{t \downarrow 0} \frac{1}{t} (S^\odot(t)x^\odot - x^\odot) = G^\odot x^\odot,$$

where the limits are in the strong sense. Hence these limits exist also in the weak*-sense, so $x^\odot \in D(G^*)$ and $G^*x^\odot = G^\odot x^\odot \in X^\odot$. This proves that $G^\odot \subseteq B$.

To prove the converse inclusion, let $x^* \in D(B)$. This means that $x^* \in D(G^*)$ and $G^*x^* \in X^\odot$. But this implies that

$$\frac{1}{t} (S^\odot(t)x^* - x^*) = \frac{1}{t} (S^*(t)x^* - x^*) = \frac{1}{t} \int_0^t S^*(s)G^*x^* \, ds.$$

The integrand of the last integral being continuous since $G^*x^* \in X^\odot$, letting $t \downarrow 0$ gives $\lim_{t \downarrow 0} \frac{1}{t} (S^\odot(t)x^* - x^*) = G^*x^*$. This shows that $x^* \in D(G^\odot)$ and $G^\odot x^* = G^*x^*$, that is, $B \subseteq G^\odot$. \square

As a special case, if X is reflexive and G is the generator of a $(S(t))_{t \geq 0}$ is a C_0 -semigroup on X , then the adjoint operator G^* is the generator of the adjoint C_0 -semigroup $(S^*(t))_{t \geq 0}$ on X^* .

G.3 The inhomogeneous abstract Cauchy problem

We now take a look at the inhomogeneous abstract Cauchy problem

$$\begin{cases} u'(t) = Gu(t) + f(t), & t \in [0, T], \\ u(0) = x \end{cases} \quad (\text{G.1})$$

with initial value $x \in X$. We assume that G generates a C_0 -semigroup $(S(t))_{t \geq 0}$ on X and take $f \in L^1(0, T; X)$. The results of this subsection for $f = 0$ will be used in the Section G.5; the reason for presenting them in the present generality is that the inhomogeneous abstract Cauchy problem is tied up with the notion of maximal L^p -regularity which will be studied extensively in Volume III.

Definition G.3.1. A weak solution of (G.1) is a function $u \in L^1(0, T; X)$ such that for all $t \in [0, T]$ and $x^* \in D(G^*)$ we have

$$\langle u(t), x^* \rangle = \langle x, x^* \rangle + \int_0^t \langle u(s), G^* x^* \rangle ds + \int_0^t \langle f(s), x^* \rangle ds.$$

We have the following existence and uniqueness result for weak solutions.

Theorem G.3.2. The problem (G.1) admits a unique weak solution u . It is given by the convolution formula

$$u(t) = S(t)x + \int_0^t S(t-s)f(s) ds. \quad (\text{G.2})$$

If $f \in L^p(0, T; X)$ with $1 \leq p \leq \infty$, then $u \in L^p(0, T; X)$.

Proof. We begin with the existence part. It is an easy consequence of Proposition G.2.3 (3) that u is a weak solution corresponding to the initial value x if and only if $t \mapsto u(t) - S(t)x$ is a weak solution corresponding to the initial value 0. Therefore, without loss of generality we may assume that $x = 0$.

Let u be given by (G.2). Then $u \in L^1(0, T; X)$; if $f \in L^p(0, T; X)$, then $u \in L^p(0, T; X)$. By Fubini's theorem and Proposition G.2.3 (3), for all $t \in [0, T]$ and $x^* \in D(G^*)$ we have

$$\begin{aligned} \int_0^t \langle u(s), G^* x^* \rangle ds &= \int_0^t \int_0^s \langle f(r), S^*(s-r)G^* x^* \rangle dr ds \\ &= \int_0^t \int_r^t \langle f(r), S^*(s-r)G^* x^* \rangle ds dr \\ &= \int_0^t \langle f(r), S^*(t-r)x^* - x^* \rangle dr \\ &= \langle u(t), x^* \rangle - \int_0^t \langle f(r), x^* \rangle dr. \end{aligned}$$

This shows that u is a weak solution.

To prove uniqueness, suppose that u and \tilde{u} are weak solutions of (G.1). Then $v := u - \tilde{u}$ is integrable and satisfies $\langle v(t), x^* \rangle = \int_0^t \langle v(s), G^* x^* \rangle ds$ for all $x^* \in D(G^*)$ and $t \in [0, T]$. Put

$$w(t) := \int_0^t \int_0^s v(r) dr ds.$$

By the fundamental theorem of calculus, w is continuously differentiable on $[0, T]$ and

$$\langle w'(t), x^* \rangle = \int_0^t \langle v(s), x^* \rangle ds = \int_0^t \int_0^s \langle v(r), G^* x^* \rangle dr ds = \langle w(t), G^* x^* \rangle.$$

For all $x^* \in D(G^\odot)$ and $t \in (0, T]$ the function $s \mapsto g_{x^*}(s) := \langle S(t-s)w(s), x^* \rangle$ is continuously differentiable on $[0, t]$ with derivative

$$g'_{x^*}(s) = \frac{d}{ds} \langle w(s), S^*(t-s)x^* \rangle = \langle w(s), G^\odot x^* \rangle + \langle w'(s), S^*(t-s)x^* \rangle = 0,$$

using that $x^* \in D(G^*)$ and $G^* x^* = G^\odot x^*$. It follows that g_{x^*} is constant on $[0, t]$. Hence

$$\langle w(t), x^* \rangle = g_{x^*}(t) = g_{x^*}(0) = \langle S(t)w(0), x^* \rangle = 0.$$

We have shown that $\int_0^t \int_0^s \langle v(r), x^* \rangle dr ds = 0$ for all $t \in [0, T]$. It follows that $\langle v, x^* \rangle = 0$ almost everywhere for all $x^* \in D(G^\odot)$. Since $D(G^\odot)$ is weak*-dense (it is a dense subspace of the weak*-dense subspace X^\odot) it follows that $v = 0$ almost everywhere by Proposition 1.1.25. \square

G.4 The Hille–Yosida theorem

In the remainder of this appendix the Banach space X will always be taken to be complex. The real case can be treated by complexification.

The following proposition identifies the resolvent of the generator of a C_0 -semigroup with the Laplace transform of the semigroup:

Proposition G.4.1. *Suppose that G is the generator of a C_0 -semigroup $(S(t))_{t \geq 0}$ on a Banach space X , and fix constants $M \geq 1$ and $\omega \in \mathbb{R}$ such that $\|S(t)\| \leq M e^{\omega t}$ for all $t \geq 0$. Then $\{\lambda \in \mathbb{C} : \Re \lambda > \omega\} \subseteq \rho(G)$, and on this set the resolvent of G is given as the Laplace transform of $(S(t))_{t \geq 0}$:*

$$R(\lambda, G)x = \int_0^\infty e^{-\lambda t} S(t)x dt, \quad x \in X.$$

As a consequence, for $\Re \lambda > \omega$ we have

$$\|R(\lambda, G)\| \leq \frac{M}{\Re \lambda - \omega}.$$

Proof. Fix $x \in X$ and define $R_\lambda x := \int_0^\infty e^{-\lambda t} S(t)x \, dt$. From the semigroup property we obtain

$$\begin{aligned} \frac{1}{h}(S(h) - I)R_\lambda x &= \frac{1}{h} \int_0^\infty e^{-\lambda t} (S(t+h) - S(t))x \, dt \\ &= \frac{1}{h} \left(e^{\lambda h} \int_h^\infty e^{-\lambda s} S(s)x \, ds - \int_0^\infty e^{-\lambda t} S(t)x \, dt \right) \\ &= \frac{1}{h} (e^{\lambda h} - 1) \int_h^\infty e^{-\lambda t} S(t)x \, dt - \frac{1}{h} \int_0^h e^{-\lambda t} S(t)x \, dt \end{aligned}$$

and hence

$$\lim_{h \downarrow 0} \frac{1}{h} (S(h) - I)R_\lambda x = \lambda R_\lambda x - x.$$

It follows that $R_\lambda x \in D(G)$ and $GR_\lambda x = \lambda R_\lambda x - x$. This shows that the bounded operator R_λ is a right inverse for $\lambda - G$.

Integrating by parts and using that $\frac{d}{dt} S(t)x = S(t)Gx$ for $x \in D(G)$ we obtain

$$\lambda \int_0^T e^{-\lambda t} S(t)x \, dt = x - e^{-\lambda T} S(T)x + \int_0^T e^{-\lambda t} S(t)Gx \, dt.$$

Since $\Re \lambda > \omega$, sending $T \rightarrow \infty$ gives $\lambda R_\lambda x = x + R_\lambda Gx$. This shows that R_λ is also a left inverse. It follows that $\lambda \in \rho(G)$ and $R(\lambda, G) = R_\lambda$.

The estimate for the resolvent follows from

$$\begin{aligned} \left\| \int_0^\infty e^{-\lambda t} S(t)x \, dt \right\| &\leq \int_0^\infty e^{-\Re \lambda t} \|S(t)x\| \, dt \\ &\leq M \|x\| \int_0^\infty e^{(\omega - \Re \lambda)t} \, dt = \frac{M}{\Re \lambda - \omega} \|x\|. \end{aligned}$$

□

We continue with a useful approximation result.

Proposition G.4.2. *Let G be a closed and densely defined operator in X , and suppose that for some $\omega \in \mathbb{R}$ we have $\{\Re \lambda > \omega\} \subseteq \rho(G)$ and*

$$\|R(\lambda, G)\| \leq \frac{M}{\Re \lambda - \omega}, \quad \Re \lambda > \omega.$$

Then for all $x \in X$ we have

$$\lim_{\lambda \rightarrow \infty} \lambda R(\lambda, G)x = x.$$

Proof. First let $x \in D(G)$ and fix an arbitrary $\mu \in \rho(G)$. Then $x = R(\mu, G)y$ for $y := (\mu - G)x$. Using the resolvent identity and the estimate on the resolvent to get

$$\begin{aligned} \lim_{\lambda \rightarrow \infty} \lambda R(\lambda, G)x &= \lim_{\lambda \rightarrow \infty} \lambda R(\lambda, G)R(\mu, G)y \\ &= \lim_{\lambda \rightarrow \infty} \frac{\lambda}{\lambda - \mu} (R(\mu, G) - R(\lambda, G))y = R(\mu, G)y = x. \end{aligned}$$

For general $x \in X$ the claim then follows by approximation with elements from $D(G)$, using the uniform boundedness of the resolvent for $\Re \lambda \geq \omega + 1$. \square

The main generation theorem for C_0 -semigroups is the Hille–Yosida theorem, which gives necessary and sufficient conditions for a linear operator to be the generator of a C_0 -semigroup in terms of resolvent growth. We will only need the version for contraction semigroups which is somewhat easier to state and prove. Its extension to general C_0 -semigroups can be reduced to this case by first rescaling G (to reduce to bounded semigroups) and then renorming X (to reduce to contraction semigroups); this will be discussed in the Notes.

Theorem G.4.3 (Hille–Yosida). *For a densely defined linear operator G in X the following assertions are equivalent:*

- (1) G generates a C_0 -contraction semigroup on X ;
- (2) $\{\lambda \in \mathbb{C} : \Re \lambda > 0\} \subseteq \rho(G)$ and

$$\|R(\lambda, G)\| \leq \frac{1}{\Re \lambda}, \quad \Re \lambda > 0.$$

Proof. The implication (1) \Rightarrow (2) follows from Proposition G.4.2.

In the converse direction, assume that (2) holds. We introduce the *Yosida approximations* $G_n := nGR(n, G) = n^2R(n, G) - nI$, $n \geq 1$. These operators are bounded, and Proposition G.4.2 implies $\lim_{n \rightarrow \infty} G_n x = Gx$ for all $x \in D(G)$. Also,

$$\|e^{tG_n}\| \leq e^{n^2\|R(n, G)\|t} e^{-nt} \leq e^{nt} e^{-nt} = 1. \quad (\text{G.3})$$

Fix $x \in D(G)$ and $t \geq 0$. The identity

$$\begin{aligned} e^{tG_n}x - e^{tG_m}x &= \int_0^t \frac{d}{ds} [e^{(t-s)G_m} e^{sG_n}x] ds \\ &= \int_0^t e^{(t-s)G_m} e^{sG_n} (G_n x - G_m x) ds \end{aligned}$$

and (G.3) imply that

$$\|e^{tG_n}x - e^{tG_m}x\| \leq t \|G_n x - G_m x\|.$$

Therefore $(e^{tG_n}x)_{n \geq 1}$ is Cauchy in X for all $x \in D(G)$ and the limit $S(t)x := \lim_{n \rightarrow \infty} e^{tG_n}x$ exists for all $x \in D(G)$, uniformly on compact time intervals in $[0, \infty)$. Using (G.3), this limit in fact exists for all $x \in X$, uniformly on compact time intervals in $[0, \infty)$. Moreover, for each $t \geq 0$ the

resulting mapping $x \mapsto S(t)x$ is linear and contractive. It remains to verify that the contractions $S(t)$, $t \geq 0$, form a C_0 -semigroup on X and that G is its generator.

It is clear that $S(0) = I$. The semigroup property follows from

$$S(t)S(s)x = \lim_{n \rightarrow \infty} e^{tG_n} e^{sG_n} x = \lim_{n \rightarrow \infty} e^{(t+s)G_n} x = S(t+s)x,$$

using the uniform boundedness of the sequence $(e^{tG_n})_{n \geq 1}$ in the first identity and that the properties of the power series of the exponential function in the second.

Next we prove the strong continuity. For $x \in D(G)$ we have

$$S(t)x - x = \lim_{n \rightarrow \infty} e^{tG_n} x - x = \lim_{n \rightarrow \infty} \int_0^t e^{sG_n} G_n x \, ds = \int_0^t S(s)Gx \, ds,$$

where we used that

$$\begin{aligned} \|e^{sG_n} G_n x - S(s)Gx\| &\leq \|e^{sG_n} (G_n x - Gx)\| + \|(e^{sG_n} - S(s))Gx\| \\ &\leq \|G_n x - Gx\| + \|(e^{sG_n} - S(s))Gx\| \rightarrow 0. \end{aligned}$$

Therefore, still for $x \in D(G)$,

$$\lim_{t \downarrow 0} S(t)x - x = \lim_{t \downarrow 0} \int_0^t S(s)Gx \, ds = 0,$$

uniformly for $s \in [0, t]$. Once again the strong continuity for general $x \in X$ follows from this by approximation.

It remains to check that G is the generator of $(S(t))_{t \geq 0}$. Let us call this generator B . By what we have already proved, for $x \in D(G)$ we have

$$\lim_{t \downarrow 0} \frac{1}{t} (S(t)x - x) = \lim_{t \downarrow 0} \frac{1}{t} \int_0^t S(s)Gx \, ds = Gx,$$

so $x \in D(B)$ and $Bx = Gx$. Since both G and B are closed and share the open right-half plane in their resolvent sets, this implies $G = B$ (use that for $\lambda \in \rho(G) \cap \rho(B)$, $\lambda - G$ is surjective and $\lambda - B$ is injective). \square

Example G.4.4. Consider the first derivative $Gf = -f'$ with domain $D(G) = W^{1,p}(\mathbb{R}; X)$. We will check that G is the generator of the translation group $S(t)f(s) = f(s - t)$ on $L^p(\mathbb{R}; X)$, which can be checked to be strongly continuous and isometric on $L^p(\mathbb{R}; X)$ for all $p \in [1, \infty)$. For the moment, denote this generator by B . By routine estimates it follows that $C_c^1(\mathbb{R}; X) \subseteq D(B)$ and $Bf = -f' = Gf$. Since $C_c^1(\mathbb{R}; X)$ is dense in $L^p(\mathbb{R}; X)$ and invariant under translations, $C_c^1(\mathbb{R}; X)$ is dense in $D(B)$ by Lemma G.2.4. By Lemma 2.5.5, $C_c^1(\mathbb{R}; X)$ is also dense in $W^{1,p}(\mathbb{R}; X) = D(G)$. Since both G and B are closed operators (the latter since semigroup generators are always closed), it follows that $D(B) = D(G)$ and hence $B = G$.

Corollary G.4.5. *Let G be a densely defined operator on a Hilbert space H . The following assertions are equivalent:*

- (1) G generates a C_0 -semigroup of contractions on H ;
- (2) $\mu - G$ has dense range for some $\mu > 0$ and $-\Re(Gh|h) \geq 0$ for all $h \in D(G)$.

Proof. (1): For all $\mu > 0$ we have $\mu \in \varrho(A)$ and therefore the range of $\mu - A$ equals all of H .

Since $\|S(t)\| \geq 1$ for all $t \geq 0$, for all $h \in H$ the function $f_h(t) := \|S(t)h\|^2 = (S(t)h|S(t)h)$ is non-increasing. If $h \in D(G)$, the f_h is continuously differentiable with derivative $f'_h(t) \leq 0$, so

$$f'_h(t) = (GS(t)h|S(t)h) + (S(t)h|GS(t)h) = 2\Re(AS(t)h|S(t)h) \leq 0.$$

For $t = 0$ this gives $\Re(Gh|h) \leq 0$.

(2): There is no loss of generality in assuming that $\mu = 1$. By assumption, for all $\lambda > 0$ and non-zero $h \in D(G)$ we have $\lambda\|h\|^2 \leq \Re((\lambda - G)h|h) \leq \|(\lambda - G)h\|\|h\|$, so

$$\|(\lambda - G)h\| \geq \lambda\|h\|. \tag{G.4}$$

In particular $\lambda - G$ is injective. Taking $\lambda = 1$ we find that $I - G$ is invertible.

Now suppose, for a contradiction, that $\lambda_1 - G$ fails to be invertible for some $\lambda_1 > 0$. Set $\lambda_t := (1 - t) + t\lambda_0$. Then $\lambda_t > 0$ for all $t \in [0, 1]$. Let $t_0 := \inf\{t \in [0, 1] : \lambda_t \in \sigma(G)\}$. Then $t_0 \in (0, 1]$ (since $\lambda_0 = 1$ and $1 \in \varrho(G)$) and $\lim_{t \uparrow t_0} \|R(\lambda_t, G)\| = \infty$ since resolvent norms diverge as we approach the boundary of the spectrum by Lemma G.1.3. But this clearly contradicts (G.4), which tells us that $\|R(\lambda_t, G)\| \leq 1/\lambda_t \leq 1/\min\{1, \lambda_1\}$ for all $t \in [0, t_0)$.

It follows that for all $\lambda > 0$ we have $\lambda \in \varrho(G)$ and, by (G.4), implies that $\|R(\lambda, G)\| \leq 1/\lambda$. Therefore G is the generator of a C_0 -semigroup of contractions by the Hille–Yosida theorem. \square

G.5 Analytic semigroups

For $\omega \in (0, \pi)$ consider the open sector

$$\Sigma_\omega := \{z \in \mathbb{C} \setminus \{0\} : |\arg(z)| < \omega\},$$

where the argument is taken in $(-\pi, \pi)$.

Definition G.5.1. *A C_0 -semigroup $(S(t))_{t \geq 0}$ on a Banach space X is called analytic on Σ_ω if for all $x \in X$ the function $t \mapsto S(t)x$ extends analytically to Σ_ω and satisfies*

$$\lim_{z \in \Sigma_\omega, z \rightarrow 0} S(z)x = x.$$

We call $(S(t))_{t \geq 0}$ an analytic C_0 -semigroup if $(S(t))_{t \geq 0}$ is analytic on Σ_ω for some $\omega \in (0, \pi)$.

If $(S(t))_{t \geq 0}$ is analytic on Σ_ω , then for all $z_1, z_2 \in \Sigma_\omega$ we have

$$S(z_1)S(z_2) = S(z_1 + z_2).$$

Indeed, for each $x \in X$ the functions $z_1 \mapsto S(z_1)S(t)x$ and $S(z_1 + t)x$ are analytic extensions of $s \mapsto S(s + t)x$ and are therefore equal. Repeating this argument, the functions $z_2 \mapsto S(z_1)S(z_2)x$ and $S(z_1 + z_2)x$ are analytic extensions of $t \mapsto S(z_1 + t)x$ and are therefore equal.

As in the proof of Proposition G.2.2, the uniform boundedness theorem implies that if $(S(t))_{t \geq 0}$ is analytic on Σ_ω , then $(S(t))_{t \geq 0}$ is uniformly bounded on $\Sigma_{\omega'} \cap B(0, r)$ for all $0 < \omega' < \omega$ and $r \geq 0$. The same argument as in Proposition G.2.2 then gives exponential boundedness on $\Sigma_{\omega'}$ for all $0 < \omega' < \omega$, in the sense that there are constants $M \geq 1$ and $c' = c_{\omega'} \in \mathbb{R}$ such that

$$\|S(e^{i\nu t})\| \leq M e^{c' t}, \quad |\nu| \leq \omega', \quad t \geq 0.$$

We say that $(S(t))_{t \geq 0}$ a *bounded analytic C_0 -semigroup on Σ_ω* if $(S(t))_{t \geq 0}$ is analytic and uniformly bounded on Σ_ω . *Analytic C_0 -contraction semigroups on Σ_ω* are defined similarly. There is a rather subtle point here: the boundedness and contractivity is imposed on a sector, not just on the positive real line. That this makes a difference is shown by simple example of the rotation group on $H = \mathbb{C}^2$, given by

$$S(t) = \begin{pmatrix} \cos t & -\sin t \\ \sin t & \cos t \end{pmatrix}.$$

For each $t \in \mathbb{R}$ we have $\|S(t)\| = 1$. Upon replacing t by a complex parameter z the group extends analytically to the entire complex plane, but it is unbounded on every sector Σ_θ . It may even happen that a bounded analytic C_0 -semigroup is contractive on the positive real line, yet fails to be an analytic C_0 -contraction semigroup; an example is discussed in the Notes.

Theorem G.5.2. *For a closed and densely defined operator G on a Banach space X the following assertions are equivalent:*

- (1) *there exists $\eta \in (0, \frac{1}{2}\pi)$ such that G generates a bounded analytic C_0 -semigroup on Σ_η ;*
- (2) *there exists $\theta \in (\frac{1}{2}\pi, \pi)$ such that $\Sigma_\theta \subseteq \varrho(G)$ and*

$$\sup_{\lambda \in \Sigma_\theta} \|\lambda R(\lambda, G)\| < \infty.$$

Denoting the suprema of all admissible η and θ in (1) and (2) by $\omega_{\text{holo}}(G)$ and $\omega_{\text{res}}(G)$ respectively, we have

$$\omega_{\text{res}}(G) = \frac{1}{2}\pi + \omega_{\text{holo}}(G).$$

Under the equivalent conditions (1) and (2) we have the inverse Laplace transform representation

$$S(t)x = \frac{1}{2\pi i} \int_{\Gamma} e^{zt} R(z, G)x \, dz, \quad t > 0, \quad x \in X,$$

where $\Gamma = \Gamma_{\theta', B}$ is the upwards oriented boundary of $\Sigma_{\theta'} \setminus B$, for any $\theta' \in (\frac{1}{2}\pi, \theta)$ and any closed ball B centred at the origin.

Proof. By Cauchy's theorem, if the integral representation holds for some choice of $\theta' \in (\frac{1}{2}\pi, \theta)$ and a closed ball B centred at the origin, then it holds for any such θ' and B .

(1) \Rightarrow (2): We start with the preliminary observation that by Proposition G.4.1, if a linear operator \tilde{G} generates a uniformly bounded C_0 -semigroup $(\tilde{S}(t))_{t \geq 0}$ on a Banach space X , then, by Proposition G.4.1, the open right half-plane $\mathbb{C}_+ = \{\Re \lambda > 0\}$ is contained in the resolvent set of \tilde{G} and we have the bound $\|\tilde{R}(\lambda, \tilde{G})\| \leq M/\Re \lambda$ for all $\lambda \in \mathbb{C}_+$. Moreover, for all $\theta \in (0, \frac{1}{2}\pi)$ we have $\Re \lambda \geq |\lambda| \cos(\theta)$ and therefore

$$\sup_{\lambda \in \Sigma_{\theta}} \|\lambda R(\lambda, \tilde{G})\| \leq \frac{M}{\cos \theta}.$$

Now if G generates a C_0 -semigroup which is bounded on a sector Σ_{η} with $\eta \in (0, \frac{1}{2}\pi]$, say by a constant M , we can apply the above reasoning to the bounded semigroups $S(e^{i\theta'} t)$, with $\theta' \in (0, \eta)$, and (after passing to the limit $\theta' \rightarrow \eta$) obtain that for all $\theta \in (0, \frac{1}{2}\pi + \eta)$,

$$\sup_{\lambda \in \Sigma_{\theta}} \|\lambda R(\lambda, G)\| \leq \frac{M}{\cos(\theta - \eta)}.$$

This gives (2). Optimising the various choices of angles, this also gives the inequality $\omega_{\text{res}}(G) \leq \frac{1}{2}\pi + \omega_{\text{holo}}(G)$.

(2) \Rightarrow (1): The proof proceeds in two steps. First we prove the integral representation for $S(t)x$, for any contour Γ given by $\theta' \in (\frac{1}{2}\pi, \theta)$ and a ball B centre at the origin as described in the statement of the theorem. Once we have this, it is fairly straightforward to deduce (1) with $\eta = \theta'' - \frac{1}{2}\pi$ for any $\frac{1}{2} < \theta'' < \theta'$; this is done in the second step.

Step 1 – Fix a arbitrary $\theta' \in (\frac{1}{2}\pi, \theta)$ and let Γ be the boundary of $\Sigma_{\theta'} \setminus B$. See Figure G.2.

Fix $t > 0$ and $x \in X$. For $\mu > 0$ such that $\mu \notin B$ define

$$v_{\mu}(t)x = \frac{1}{2\pi i} \int_{\Gamma} e^{zt} (\mu - z)^{-1} R(z, G)x \, dz.$$

Our aim is to show that $v_{\mu}(t)x = S(t)R(\mu, G)x$. Then,

$$S(t)x = \lim_{\mu \rightarrow \infty} S(t)\mu R(\mu, G)x = \lim_{\mu \rightarrow \infty} \mu v_{\mu}(t)x = \frac{1}{2\pi i} \int_{\Gamma} e^{zt} R(z, G)x \, dz,$$

where the first equality follows from Proposition G.4.2 and the second is obtained by splitting $\Gamma = \Gamma_{r,1} \cup \Gamma_{r,2}$ with $\Gamma_{r,1} = \{z \in \Gamma : \|z\| \leq r\}$ and

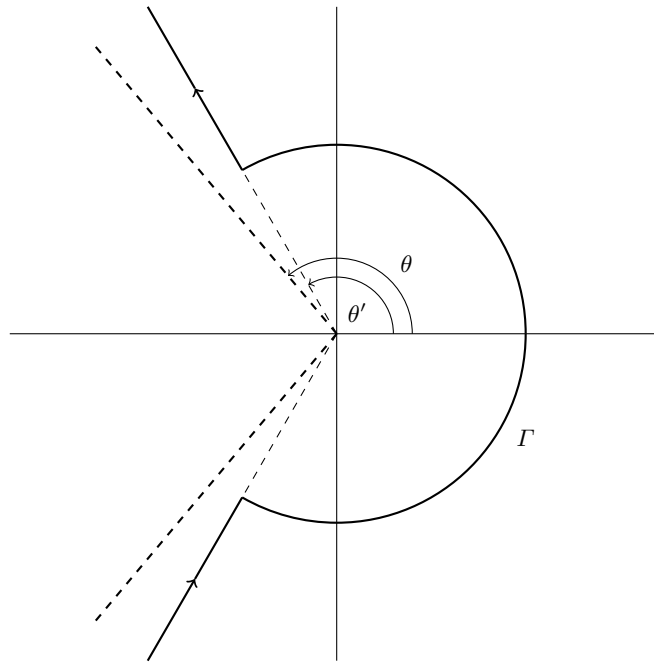

Fig. G.2: The contour Γ

$\Gamma_{r,2} = \{z \in \Gamma : \|z\| \geq r\}$: for large fixed r , the integral over $\Gamma_{r,2}$ is less than ε , uniformly with respect to $\mu \geq 2r$, while the integral over $\Gamma_{r,1}$ tends to $\frac{1}{2\pi i} \int_{\Gamma_{r,1}} e^{zt} R(z, G)x \, dz$ by dominated convergence. Now pass to the limit $r \rightarrow \infty$.

The strategy is to prove that $t \mapsto v_\mu(t)x$ is a weak solution of the Cauchy problem

$$\begin{cases} u'(t) = Gu(t), & t \in [0, T], \\ u(0) = R(\mu, G)x. \end{cases}$$

The uniqueness part of Theorem G.3.2 (with $f = 0$) then implies $v_\mu(t)x = S(t)R(\mu, G)x$.

It is easily checked that $t \mapsto v_\mu(t)$ is integrable on $[0, T]$ (even continuous), and for all $x^* \in D(G^*)$ we obtain

$$\begin{aligned}
\int_0^t \langle v_\mu(s), G^* x^* \rangle ds &= \int_0^t \frac{1}{2\pi i} \int_\Gamma e^{zs} (\mu - z)^{-1} \langle R(z, G)x, G^* x^* \rangle dz ds \\
&= \int_0^t \frac{1}{2\pi i} \int_\Gamma e^{zs} (\mu - z)^{-1} \langle zR(z, G)x - x, x^* \rangle dz ds \\
&\stackrel{(1)}{=} \int_0^t \frac{1}{2\pi i} \int_\Gamma e^{zs} (\mu - z)^{-1} \langle zR(z, G)x, x^* \rangle dz ds \\
&= \frac{1}{2\pi i} \int_\Gamma (e^{zt} - 1) (\mu - z)^{-1} \langle R(z, G)x, x^* \rangle dz \\
&\stackrel{(2)}{=} \frac{1}{2\pi i} \int_\Gamma e^{zt} (\mu - z)^{-1} \langle R(z, G)x, x^* \rangle dz - \langle R(\mu, G)x, x^* \rangle \\
&= \langle v_\mu(t), x^* \rangle.
\end{aligned}$$

Here the equality (1) follows from the observation that by Cauchy's theorem we have

$$\frac{1}{2\pi i} \int_\Gamma e^{zs} (\mu - z)^{-1} dz = 0,$$

since $\mu \notin B$ is on the right of Γ . The equality (2) follows from

$$\frac{1}{2\pi i} \int_\Gamma (\mu - z)^{-1} \langle R(z, G)x, x^* \rangle dz = \langle R(\mu, G)x, x^* \rangle$$

by the analyticity of the resolvent and Cauchy's theorem.

Step 2 – By now we have shown that

$$S(t)x = \frac{1}{2\pi i} \int_\Gamma e^{zt} R(z, G)x dz, \quad t > 0, \quad x \in X,$$

with Γ as in Step 1. This integral converges absolutely for all $t > 0$ and $x \in X$, and extends to a bounded analytic function on the sector $\Sigma_{\eta'}$, where $\eta' = \theta' - \frac{1}{2}\pi$, given by

$$S(\zeta)x = \frac{1}{2\pi i} \int_\Gamma e^{z\zeta} R(z, G)x dz, \quad \zeta \in \Sigma_{\eta'}, \quad x \in X.$$

To estimate the norm of $S(\zeta)$, by Cauchy's theorem we may take $\Gamma = \Gamma_{\theta', B_r}$ with $B_r = B(0, r)$ the ball of radius r and centre 0; the choice of r will be made shortly.

Put $M := \sup_{\lambda \in \Sigma_\theta} \|\lambda R(\lambda, G)\|$ and fix $\zeta \in \Sigma_{\eta'}$. The arc $\{|z| = r, |\arg(z)| \leq \theta\}$ contributes at most

$$\frac{1}{2\pi} \cdot 2\theta r \cdot \exp(r|\zeta|) \frac{M}{r} = \frac{\theta M}{\pi} \exp(r|\zeta|),$$

while each of the rays $\{|z| \geq r, \arg(z) = \pm\theta\}$ contributes at most

$$\frac{1}{2\pi} \cdot \frac{M}{r} \int_r^\infty \exp(-\rho|\zeta| |\cos(\theta)|) d\rho \leq \frac{1}{2\pi} \cdot \frac{M}{|\zeta| |\cos(\theta)|}.$$

It follows that

$$\|S(\zeta)\| \leq \frac{M}{\pi} \left(\theta \exp(r|\zeta|) + \frac{1}{r|\zeta|\cos(\theta)} \right).$$

Taking $r = 1/|\zeta|$ and keeping in mind that the estimate holds for all $\theta' \in (\frac{1}{2}\pi, \theta)$, we obtain the uniform bound

$$\|S(\zeta)\| \leq \frac{M}{\pi} \left(\theta e + \frac{1}{|\cos(\theta)|} \right), \quad z \in \Sigma_\eta, \quad \eta := \frac{1}{2}\pi - \theta. \quad (\text{G.5})$$

It remains to prove strong continuity on each of the sectors $\Sigma_{\theta'' - \frac{1}{2}\pi}$ with $\frac{1}{2} < \theta'' < \theta'$. First let $x \in \text{D}(G)$. Fix $\zeta \in \Sigma_{\theta'' - \frac{1}{2}\pi}$ and write $x = R(\mu, G)y$ with $\mu \in \Sigma_{\theta'} \setminus \Sigma_{\theta''}$. Inserting this in the integral expression for $S(\zeta)x$, using the resolvent identity to rewrite $R(z, G)R(\mu)y = (R(z, G) - R(\mu, G))/(\mu - z)$. Arguing as in Step 1, the integral corresponding to the term with $R(\mu, G)$ vanishes by Cauchy's theorem and the choice of μ , and we obtain

$$S(\zeta)x = \frac{1}{2\pi i} \int_\Gamma e^{z\zeta} (\mu - z)^{-1} R(z, G)y \, dz.$$

Letting $\zeta \rightarrow 0$ inside $\Sigma_{\theta'' - \frac{1}{2}\pi}$, we see that $S(\zeta)x$ converges to $\frac{1}{2\pi i} \int_\Gamma (\mu - z)^{-1} R(z, G)y \, dz = R(\mu, G)y = x$ by dominated convergence.

This proves the convergence $S(\zeta)x \rightarrow x$ for $x \in \text{D}(G)$. In view of the uniform boundedness of $S(\zeta)$ on $\Sigma_{\theta'' - \frac{1}{2}\pi}$, the convergence for general $x \in X$ follows from this. By the choices of θ' and θ'' , this also proves the inequality $\omega_{\text{res}}(G) \geq \frac{1}{2}\pi + \omega_{\text{holo}}(G)$. \square

The following result characterises analytic C_0 -semigroups directly in terms of the semigroup and its generator, without reference to the resolvent.

Theorem G.5.3. *Let G be the generator of a C_0 -semigroup $(S(t))_{t \geq 0}$ on a Banach space X . The following assertions are equivalent:*

- (1) $(S(t))_{t \geq 0}$ is bounded analytic;
- (2) $S(t)x \in \text{D}(G)$ for all $x \in X$ and $t > 0$, and

$$\sup_{t > 0} t \|GS(t)\| < \infty.$$

Proof. (1) \Rightarrow (2): Fix $t > 0$ and $x \in X$. Since

$$M := \sup_{z \in \Gamma} \|GR(z, G)\| = \sup_{z \in \Gamma} \|zR(z, G) - I\|$$

is finite, the integral $\frac{1}{2\pi i} \int_\Gamma e^{tz} R(z, G)Gx \, dz$ converges absolutely. From Hille's theorem we deduce that $S(t)x \in \text{D}(G)$ and

$$GS(t)x = \frac{1}{2\pi i} \int_\Gamma e^{tz} R(z, G)Gx \, dz.$$

By estimating this integral and letting the radius of the ball B in the definition of Γ tend to 0, it follows moreover that

$$t\|GS(t)x\| \leq \frac{M}{\pi} \|x\| \int_0^\infty te^{\rho t \cos \theta'} d\rho = \frac{M}{\pi |\cos \theta'|} \|x\|.$$

(2) \Rightarrow (1): For all $x \in D(G^n)$, $t \mapsto S(t)x$ is n times continuously differentiable and $S^{(n)}(t)x = G^n S(t)x = (GS(t/n))^n x$. Since $D(G^n)$ is dense, the boundedness of $GS(t/n)$ and closedness of the n th derivative in $C([0, T]; X)$ together imply that the same conclusion holds for $x \in X$. Moreover,

$$\|S^{(n)}(t)x\| \leq \frac{C^n n^n}{t^n} \|x\|,$$

where C is the supremum in (2). From $n! \geq n^n/e^n$ we obtain that for each $t > 0$ the series

$$S(z)x := \sum_{n=0}^\infty \frac{1}{n!} (z-t)^n S^{(n)}(t)x$$

converges absolutely on the ball $B(t, rt/eC)$ for all $0 < r < 1$ and defines an analytic function there. The union of these balls is the sector Σ_η with $\sin \eta = 1/eC$. We shall complete the proof by showing that $S(z)$ is uniformly bounded and satisfies $\lim_{z \rightarrow 0} S(z)x = x$ in $\Sigma_{\eta'}$ for each $0 < \eta' < \eta$. To this end we fix $0 < r < 1$. For $z \in B(t, rt/eC)$ we have

$$\|S(z)x\| \leq \sum_{n=0}^\infty \frac{1}{n!} r^n (t/eC)^n \frac{C^n n^n}{t^n} \|x\| \leq \sum_{n=0}^\infty r^n \|x\|.$$

This proves uniform boundedness on the sectors $\Sigma_{\eta'}$. To prove strong continuity it then suffices to consider $x \in D(G)$, for which it follows from estimating the identity

$$S(z)x - x = e^{i\theta} \int_0^r S(se^{i\theta})Gx ds$$

where $z = re^{i\theta}$. □

Remark G.5.4. Condition (2) gives a ‘real’ characterisation of analyticity. In the context of semigroups on real Banach spaces this condition could be taken as the definition for analyticity. This has the advantage of avoiding the digressions through complexified spaces. In concrete examples, however, it is often easier to check analyticity using Definition G.5.1 or condition (2) of Theorem G.5.2.

By a rescaling argument we obtain:

Corollary G.5.5. *If G generates an analytic C_0 -semigroup $(S(t))_{t \geq 0}$ on X , then*

$$\limsup_{t \downarrow 0} t\|GS(t)\| < \infty.$$

Example G.5.6 (Laplacian on \mathbb{R}^d). Consider the Laplacian $\Delta = \sum_{j=1}^d \frac{\partial^2}{\partial x_j^2}$ on $L^p(\mathbb{R}^d; X)$, $p \in [1, \infty)$, with domain $D(\Delta) = H^{2,p}(\mathbb{R}^d; X)$, the space of all $f \in L^p(\mathbb{R}^d; X)$ admitting a weak Laplacian in $L^p(\mathbb{R}^d; X)$ in the sense of Section 5.5.

We show that Δ is the generator of the heat semigroup $(H(t))_{t \geq 0}$ on $L^p(\mathbb{R}^d)$ given by $H(0) = I$ and

$$H(t)f := k_t * f, \quad t > 0,$$

where $k_t(x) = (4\pi t)^{-d/2} e^{-|x|^2/(4t)}$ is the heat kernel. By Young's inequality, $\|H(t)\| \leq \|k_t\|_{L^1(\mathbb{R}^d)} = 1$ (see Example 8.2.5) and hence each $H(t)$ is a contraction.

Let for the moment B denote the generator of this semigroup. Taking Fourier transforms, for $t > 0$ and Schwartz functions $f \in \mathcal{S}(\mathbb{R}^d; X)$ we have

$$\mathcal{F}\left(\frac{H(t)f - f}{t}\right) = \frac{e^{-4t\pi^2|\cdot|^2} - 1}{t} \mathcal{F}f.$$

As $t \downarrow 0$ the right-hand side tends to $-4\pi^2|\cdot|^2 \mathcal{F}f = \mathcal{F}(\Delta f)$ in $\mathcal{S}(\mathbb{R}^d; X)$. Therefore, by the continuity of \mathcal{F} (see Proposition 2.4.22), $\lim_{t \downarrow 0} \frac{1}{t}(H(t)f - f) \rightarrow \Delta f$ in $\mathcal{S}(\mathbb{R}^d; X)$ and hence in $L^p(\mathbb{R}^d; X)$. It follows that $f \in D(B)$ and $Bf = \Delta f$. By repeating the density argument of the preceding example, this time using Lemma 5.5.5, the domain of the generator of $H(t)$ is seen to equal $H^{2,p}(\mathbb{R}^d; X)$, and therefore $B = \Delta$ with equality of domains.

We claim that for $z \in \mathbb{C}$ with $\Re z > 0$, the complex heat kernel k_z still belongs to $L^1(\mathbb{R}^d)$, and the function $z \mapsto k_z$ is holomorphic as an $L^1(\mathbb{R}^d)$ -valued function. To check this let $t = \Re z$ and note that, with $c(z) := \cos(\arg z)$, $|z| = t/c(z)$ and $\Re(1/z) = \Re \bar{z}/|z|^2 = t^{-1}c^2(z)$. Hence we find that

$$\int_{\mathbb{R}^d} |k_z(x)| \, dx = c^{-d/2}(z) \int_{\mathbb{R}^d} k_{t/c^2(z)}(x) \, dx \leq \frac{1}{\cos^{d/2} \theta}.$$

It follows that the heat semigroup extends analytically to $\{z \in \mathbb{C} : \Re z > 0\}$ by the formula

$$H(z)f = k_z * f, \quad \Re z > 0.$$

Moreover, $H(z)$ is uniformly bounded and strongly continuous on every sector Σ_ω with $0 < \omega < \frac{1}{2}\pi$.

Finally let us mention that if $p \in (1, \infty)$ and X is a UMD space, then $D(\Delta) = H^{2,p}(\mathbb{R}^d; X) = W^{2,p}(\mathbb{R}^d; X)$ by Theorem 5.6.11.

G.6 Stone's theorem

In this final section we prove a celebrated result due to Stone which asserts that a linear operator A with dense domain $D(A)$ in a complex Hilbert space

H is self-adjoint if and only if iA generates a strongly continuous group of unitary operators on H .

When A is a densely defined linear operator on a Hilbert space H , upon identifying H with its dual H^* via the Riesz representation theorem the adjoint operator A^* on H^* induces an operator on H , which we shall denote by A^* . Thus, by definition, $D(A^*)$ consists of all $h \in H$ with the property that there exists an element $h' \in H$ such that

$$(h|h') = (Ax|h), \quad x \in D(A),$$

and in this case $A^*h := h'$. Thus, by definition, we have the identity

$$(Ah|h') = (h|A^*h'), \quad h \in D(A), \quad h' \in D(A^*).$$

A densely defined operator A on a Hilbert space is called *self-adjoint* if $D(A) = D(A^*)$ and $Ah = A^*h$ for all $h \in D(A) = D(A^*)$. We need the following standard fact about the spectra of self-adjoint operators.

Proposition G.6.1. *If A is a self-adjoint operator on a Hilbert space H , then $\sigma(A) \subseteq \mathbb{R}$ and*

$$\|R(\lambda, A)\| \leq \frac{1}{|\Im \lambda|}, \quad \lambda \in \mathbb{C} \setminus \mathbb{R}.$$

Proof. Let $\lambda = \alpha + i\beta$ with $\beta \neq 0$. For all $x \in D(A)$ we have $(Ax|x) = \overline{(x|Ax)}$ and therefore $(Ax|x) \in \mathbb{R}$. Then,

$$\|(\lambda - A)x\| \|x\| \geq |((\lambda - A)x|x)| = |\alpha(x|x) - (Ax|x) + i\beta(x|x)| \geq |\beta| \|x\|^2.$$

This implies that $\|(\lambda - A)x\| \geq \beta \|x\|$ and therefore $\lambda - A$ is injective and has closed range. The same argument can be applied to $\bar{\lambda}$ and allows us to conclude that $\bar{\lambda} - A$ is injective and has closed range.

We claim that $\lambda - A$ has dense range. If this were not the case, we could pick a non-zero x orthogonal to the range of $\lambda - A$. Then for all $y \in D(A)$ we have $(x|(\lambda - A)y) = 0$, implying that $x \in D(A^*) = D(A)$ and $(\bar{\lambda} - A)x|y) = (x|(\lambda - A)y) = 0$ for all $y \in D(A)$. Since $D(A)$ is dense (this is part of the definition of a self-adjoint operator), it follows that $(\bar{\lambda} - A)x = 0$. This contradicts the injectivity of $\bar{\lambda} - A$.

It follows that $\lambda - A$ is bijective, hence invertible, and the inequality $\|(\lambda - A)x\| \geq \beta \|x\|$ implies $\|R(\lambda, A)\| \leq 1/|\beta|$. \square

Theorem G.6.2 (Stone). *For a densely defined operator $(A, D(A))$ in H , the following assertions are equivalent:*

- (1) A is self-adjoint;
- (2) iA is the generator of a C_0 -group of unitary operators.

Proof. (1) \Rightarrow (2): Suppose first that A is self-adjoint. We could use the spectral theorem for (possibly unbounded) self-adjoint operators to define $U(t) = \exp(itA)$, $t \in \mathbb{R}$, and proceed by showing that this defines a unitary C_0 -group, but for reasons of self-containedness we will follow a more elementary approach.

By Proposition G.6.1, the spectrum of A is contained in the real line and for all $\lambda \in \mathbb{C} \setminus \mathbb{R}$ we have $\|(\lambda - A)^{-1}\| \leq 1/|\Im \lambda|$. Hence by the Hille–Yosida theorem (Theorem G.4.3) $\pm iA$ generate C_0 -contraction semigroups, say $(S_{\pm}(t))_{t \geq 0}$. For $x \in D(A)$, differentiating $f(t) := S_-(t)S_+(t)x$ gives $f'(t) = -iAf(t) + iAf(t) = 0$, so f is constant, and since $f(0) = x$ it follows that $S_-(t)S_+(t)x = x$ for all $x \in D(A)$. By boundedness this extends to all $x \in X$ and therefore $S_-(t)S_+(t) = I$. The same argument proves that also $S_+(t)S_-(t) = I$. Also, since $(iA)^* = -iA^* = -iA$, we have $S_-(t) = S_+^*(t)$ and vice versa. Setting $U(t) := S_+(t)$ and $U(-t) := S_-(t)$, it follows that the operators $U(\pm t)$ are unitary. The verification of the group property $U(r + s) = U(r)U(s)$ is now clear, and so is the strong continuity. Thus $(U(t))_{t \in \mathbb{R}}$ is a C_0 -group, and its generator equals iA .

(2) \Rightarrow (1): Suppose iA generates the unitary C_0 -group $(U(t))_{t \in \mathbb{R}}$. From $U(-t) = (U(t))^{-1} = U^*(t)$ we see that $(U^*(t))_{t \in \mathbb{R}}$ is a strongly continuous group as well. To determine its generator, which we call B for the moment, suppose that $x \in D(A)$ and $h \in D(B)$. Then

$$(x|Bh) = \lim_{t \rightarrow 0} \frac{1}{t}(x|U^*(t)h - h) = \lim_{t \rightarrow 0} \frac{1}{t}(U(t)x - x|h) = (iAx|h).$$

This shows that $h \in D(A^*)$ and $-iA^*h = (iA)^*h = Bh$. In the converse direction, if $h \in D(A^*)$, then for all $x \in D(A)$ we have

$$(x|-iA^*h) = (iAx|h) = \lim_{t \rightarrow 0} \frac{1}{t}(U(t)x - x|h) = \lim_{t \rightarrow 0} \frac{1}{t}(x|U^*(t)h - h) = (x|Bh).$$

This shows that $h \in D(B)$ and $Bh = -iA^*h$. We conclude that $B = -iA^*$ with equal domains. But then the identity

$$\frac{1}{t}(U(-t)x - x) = \frac{1}{t}(U^*(t)x - x)$$

shows that $x \in D(A)$ if and only if $x \in D(A^*)$ and $-iAx = Bx = -iA^*x$. \square

G.7 Notes

Section G.1

The material of this section is entirely standard and can be found in most textbooks on Functional Analysis.

Section G.2

Excellent introductions to the theory of C_0 -semigroups include the monographs [Davies \[1980\]](#), [Engel and Nagel \[2000\]](#), [Goldstein \[1985\]](#), [Pazy \[1983\]](#), [Tanabe \[1979\]](#). The monumental 1957 treatise of [Hille and Phillips \[1957\]](#) is freely available on-line (http://www.ams.org/online_bks/coll131/). A fair amount of semigroup theory can be understood from the point of view of Laplace transforms; this aspect is highlighted in [Arendt, Batty, Hieber, and Neubrander \[2011\]](#).

Propositions [G.2.5](#) and [G.2.7](#) are due to [Phillips \[1955\]](#) and [Phillips \[1951\]](#), respectively; the proof of the latter presented here is from [Miyadera \[1951\]](#). See also [Hille and Phillips \[1957\]](#), where further references are given. Corollary [G.2.6](#) admits a partial extension to a larger class of Banach spaces: it was observed in [Van Neerven \[1990\]](#) that if X^* has the RNP, then the adjoint semigroup $(S^*(t))_{t \geq 0}$ is $C_{>0}$. In particular, the adjoint of a C_0 -group on a Banach space whose dual has the RNP is a C_0 -group again.

The material on adjoint semigroups is taken from [Van Neerven \[1992\]](#).

Section G.3

General references on evolution equations include [Amann \[1995\]](#), [Lunardi \[1995\]](#), [Prüss and Simonett \[2016\]](#), [Tanabe \[1979, 1997\]](#), [Yagi \[2010\]](#).

Theorem [G.3.2](#) is due to [Ball \[1977\]](#), who also proved the following converse: if [\(G.1\)](#) admits a unique weak solution for all $f \in L^1(0, T; X)$ and initial values $x \in X$, then G is the generator of a C_0 -semigroup on X .

The convolution formula [\(G.2\)](#) is often taken as the definition of a *mild solution*. Typical questions then revolve around proving regularity properties of mild solutions in terms of properties of the forcing function f and the semigroup $(S(t))_{t \geq 0}$. We refer to [[Pazy, 1983, Chapter 4](#)] for some elementary results in this direction. For the treatment of certain classes of non-linear Cauchy problems it is of particular importance to know whether the mild solutions have *maximal L^p -regularity*, meaning that for all $f \in L^p(0, T; X)$ the solution u belongs to $W^{1,p}(0, T; X) \cap L^p(0, T; D(A))$. A necessary condition for this is that $(S(t))_{t \geq 0}$ be analytic; it is a classical result that this condition is also sufficient in Hilbert spaces. For analytic C_0 -semigroups on Banach spaces the *maximal L^p -regularity problem*, which asks if the converse holds, has recently be settled by [Kalton and Lancien \[2000\]](#) (who gave a counterexample in an L^p -space) and [Weis \[2001b\]](#) (where necessary and sufficient conditions were obtained for maximal L^p -regularity in UMD Banach spaces). We take up this topic in more detail in the third volume.

Section G.4

The Hille–Yosida theorem (Theorem [G.4.3](#)) can be generalised to arbitrary C_0 -semigroups in two steps. First, if $(S(t))_{t \geq 0}$ is uniformly bounded, the version

presented in the text may be applied in the Banach space $(X, \|\cdot\|)$, where $\|x\| := \sup_{t \geq 0} \|S(t)x\|$. With respect to this equivalent norm, $(S(t))_{t \geq 0}$ is contractive. Secondly, if $(S(t))_{t \geq 0}$ is arbitrary and satisfies $\|S(t)\| \leq Me^{\omega t}$ for all $t \geq 0$, the previous version of the theorem may be applied to the semigroup $(e^{-\omega t}S(t))_{t \geq 0}$ which is uniformly bounded. Upon going through the details one arrives at the following result.

Theorem G.7.1 (Hille–Yosida). *For a densely defined operator G on a Banach space X and constants $M \geq 1$ and $\omega \in \mathbb{R}$, the following assertions are equivalent:*

- (1) G generates a C_0 -semigroup on X satisfying $\|S(t)\| \leq Me^{\omega t}$ for all $t \geq 0$;
- (2) $\{\lambda \in \mathbb{C} : \lambda > \omega\} \subseteq \varrho(A)$ and $\|(R(\lambda, A))^k\| \leq M/(\lambda - \omega)^k$ for all $\lambda > \omega$ and $k = 1, 2, \dots$;
- (3) $\{\lambda \in \mathbb{C} : \Re \lambda > \omega\} \subseteq \varrho(A)$ and $\|(R(\lambda, A))^{-1}\|^k \leq M/(\Re \lambda - \omega)^k$ for all $\Re \lambda > \omega$ and $k = 1, 2, \dots$

Theorem G.7.1, in the form stated, was obtained independently and simultaneously by Hille [1948] and Yosida [1948]; the above extension to arbitrary C_0 -semigroups was found independently by Feller [1953], Miyadera [1952], and Phillips [1953].

Section G.5

A comprehensive treatment of analytic semigroups and their applications to evolution equations is given in Lunardi [1995].

An example of a bounded analytic C_0 -semigroup on \mathbb{C}^2 that is contractive on the positive real line but not on any larger sector was given by Fuhrman [1995] where it was studied for different purposes; that it has the properties just mentioned here was shown in Goldys and Van Neerven [2003].

Section G.6

Theorem G.6.2 is from Stone [1932].

H

Hardy spaces of holomorphic functions

Holomorphic functions on the sectors

$$\Sigma_\vartheta = \{z \in \mathbb{C} \setminus \{0\} : |\arg(z)| < \vartheta\},$$

play an important role in this volume. Here, and everywhere else in this book, it is implicit that $0 < \vartheta < \pi$ and arguments are taken in $(-\pi, \pi)$. The sector Σ_ϑ is the bi-holomorphic image under exponential function $\exp(z)$ of the strip

$$\mathbb{S}_\vartheta := \{z \in \mathbb{C} : |\Im z| < \vartheta\}.$$

Although we are primarily interested in holomorphic functions on sectors, we shall study holomorphic functions on strips first, and later transfer their properties to sectors. The advantage of this is that the proofs for the strip are notationally a bit easier.

H.1 Hardy spaces on a strip

Fix a real number $\vartheta > 0$.

Definition H.1.1 (The Hardy spaces $H^p(\mathbb{S}_\vartheta)$). For $1 \leq p \leq \infty$, $H^p(\mathbb{S}_\vartheta)$ is the Banach space of all holomorphic functions $f : \mathbb{S}_\vartheta \rightarrow \mathbb{C}$ for which

$$\|f\|_{H^p(\mathbb{S}_\vartheta)} := \sup_{|y| < \vartheta} \|t \mapsto f(t + iy)\|_{L^p(\mathbb{R})} < \infty.$$

Proposition H.1.2. Let $1 \leq p \leq \infty$. If $f \in H^p(\mathbb{S}_\vartheta)$, then

$$\sup_{x \in \mathbb{R}} \|n \mapsto f(x + n)\|_{\ell^p(\mathbb{Z})} \leq \left(\frac{4}{\pi} \vee \frac{2}{\pi\vartheta}\right)^{1/p} \|f\|_{H^p(\mathbb{S}_\vartheta)}$$

Proof. We will give the proof for $1 \leq p < \infty$, the case $p = \infty$ being easier. For each fixed $x \in \mathbb{R}$, the discs $D_n = \{z \in \mathbb{C} : |z - (x + n)| < \frac{1}{2} \wedge \vartheta\}$, $n \in \mathbb{Z}$,

are disjoint and contained in $\mathbb{S}_{\frac{1}{2} \wedge \vartheta}$. By the mean value theorem, Jensen's inequality, and Fubini's theorem,

$$\begin{aligned} \sum_{n \in \mathbb{Z}} |f(x+n)|^p &= \sum_{n \in \mathbb{Z}} \left| \frac{1}{|D_n|} \int_{D_n} f(t+iy) dt dy \right|^p \\ &\leq \sum_{n \in \mathbb{Z}} \frac{1}{|D_n|} \int_{D_n} |f(t+iy)|^p dt dy \\ &\leq \frac{1}{\pi(\frac{1}{2} \wedge \vartheta)^2} \int_{\{|\Im z| < \frac{1}{2} \wedge \vartheta\}} |f(t+iy)|^p dt dy \\ &\leq \frac{2}{\pi(\frac{1}{2} \wedge \vartheta)} \sup_{|y| < \vartheta} \|t \mapsto f(t+iy)\|_{L^p(\mathbb{R})}^p \leq \left(\frac{4}{\pi} \vee \frac{2}{\pi\vartheta}\right) \|f\|_{H^p(\mathbb{S}_\vartheta)}^p. \end{aligned}$$

□

Proposition H.1.3. *Let $1 \leq p \leq \infty$. If $f \in H^p(\mathbb{S}_\vartheta)$, then for all $0 < \eta < \vartheta$ we have $f \in H^\infty(\mathbb{S}_\eta)$ and*

$$\|f\|_{H^\infty(\mathbb{S}_\eta)} \leq \left(\frac{2}{\pi(\vartheta - \eta)}\right)^{1/p} \|f\|_{H^p(\mathbb{S}_\vartheta)}.$$

Proof. Fix $0 < \eta < \vartheta$ and $z \in \mathbb{S}_\eta$. Let $\delta = \vartheta - \eta$ and $D = \{w \in \mathbb{C} : |z-w| < \delta\}$. By the mean value theorem, Jensen's inequality, and Fubini's theorem,

$$\begin{aligned} |f(z)|^p &\leq \frac{1}{|D|} \int_D |f(t+iy)|^p dt dy \\ &\leq \frac{1}{\pi\delta^2} \int_{\{|y| < \delta\}} \|t \mapsto f(t+iy)\|_{L^p(\mathbb{R})}^p dy \leq \frac{2}{\pi\delta} \|f\|_{H^p(\mathbb{S}_\vartheta)}^p. \end{aligned}$$

□

The following convergence result will be needed.

Lemma H.1.4. *Let $f \in H^1(\mathbb{S}_\vartheta)$. Then for all $0 < \eta < \vartheta$,*

$$\lim_{|x| \rightarrow \infty} \sup_{|y| \leq \eta} |f(x+iy)| = 0.$$

Proof. First observe that

$$\int_{-\vartheta}^{\vartheta} \int_{\mathbb{R}} |f(u+iv)| du dv \leq 2\vartheta \|f\|_{H^1(\mathbb{S}_\vartheta)}.$$

Fix $x \in \mathbb{R}$ and $|y| \leq \eta$, put $\delta := (\vartheta - \eta)/2$, and consider the disc $D := \{z \in \mathbb{C} : |z - x - iy| < \delta\}$ and the rectangle $R := \{u + iv \in \mathbb{C} : |u| < \delta, |v| < \vartheta\}$. By the mean value theorem,

$$|f(x+iy)| \leq \frac{1}{|D|} \int_D |f(u+iv)| d(u,v) \leq \frac{1}{\pi\delta^2} \int_{R+x} |f(u+iv)| d(u,v).$$

Therefore,

$$\lim_{|x| \rightarrow \infty} \sup_{|y| \leq \eta} |f(x + iy)| \leq \lim_{|x| \rightarrow \infty} \frac{1}{\pi \delta^2} \int_{R+x} |f(u + iv)| d(u, v) = 0$$

by the dominated convergence theorem. □

The following L^p -version of the classical three lines lemma (Lemma 2.2.2) holds:

Proposition H.1.5 (Three lines lemma, L^p -version for the strip). *Let $1 \leq p \leq \infty$. If $f \in H^p(\mathbb{S}_\vartheta)$, then for all $-\vartheta < a < c < b < \vartheta$ we have*

$$\|t \mapsto f(t + ic)\|_p \leq \|t \mapsto f(t + ia)\|_p^{\frac{c-a}{b-a}} \|t \mapsto f(t + ib)\|_p^{\frac{b-c}{b-a}}.$$

Proof. By Proposition H.1.3, f is bounded on \mathbb{S}_η for all $0 < \eta < \vartheta$, so in particular f is bounded on $\{a \leq |\Im z| \leq b\}$. There is no loss of generality in assuming that $a = 0$, $b = 1$, and $c = \theta$. We apply Lemma C.2.10 (which we rotate over $\frac{1}{2}\pi$ for this purpose). We then find

$$|f(s + i\theta)| \leq \left((|f(\cdot)| * p_0(\theta, \cdot))(-s) \right)^{1-\theta} \left((|f(\cdot + i)| * p_1(\theta, \cdot))(-s) \right)^\theta,$$

where $p_0(\theta, t)$ and $p_1(\theta, t)$ are the L^1 -normalised functions obtained by rotating the functions $\widetilde{P}_0(\theta, t) = P_0(\theta, t)/(1-\theta)$ and $\widetilde{P}_1(\theta, t) = P_1(\theta, t)/\theta$ appearing in the Poisson formula for the strip. Taking L^p -norms and using Hölder's inequality with exponents $\frac{1}{1-\theta}$ and $\frac{1}{\theta}$, it follows that

$$\begin{aligned} \|s \mapsto f(s + i\theta)\|_p &\leq \left(\| |f(\cdot)| * p_0(\theta, \cdot) \|_p \right)^{1-\theta} \left(\| |f(\cdot + i)| * p_1(\theta, \cdot) \|_p \right)^\theta \\ &\leq \|f(\cdot)\|_p^{1-\theta} \|f(\cdot + i)\|_p^\theta, \end{aligned}$$

where in the last step we applied Young's inequality. □

We continue with an interpolation result. It (or rather, its sectorial version given below) will only be needed once, namely in the proof of Proposition 10.2.28.

Proposition H.1.6 (Interpolating sequences for the strip). *For all real numbers $a > 0$ the sequence $a\mathbb{Z}$ is an interpolating sequence for \mathbb{S}_ϑ , i.e., for all bounded sequences $(c_n)_{n \in \mathbb{Z}}$ there exists $f \in H^\infty(\mathbb{S}_\vartheta)$ such that*

$$f(an) = c_n \text{ for all } n \in \mathbb{Z}.$$

Moreover, there is a constant $M = M_a$ such that for any given sequence $(c_n)_{n \in \mathbb{Z}} \in \ell^\infty(\mathbb{Z})$ an interpolating function can be found of norm

$$\|f\|_{H^\infty(\mathbb{S}_\vartheta)} \leq M \|c\|_{\ell^\infty(\mathbb{Z})}.$$

Proof. By scaling it suffices to consider the case $\vartheta = 1$. The function $i \exp(\frac{1}{2}\pi z)$ maps the unit strip \mathbb{S} conformally onto the right half-plane $\mathbb{C}_+ = \{\Re z > 0\}$. On \mathbb{C}_+ , a classical theorem due to Carleson asserts that a necessary and sufficient condition for a sequence $(\zeta_n)_{n \in \mathbb{Z}}$ to be an interpolating sequence is that

$$\inf_{k \in \mathbb{Z}} \prod_{j \in \mathbb{Z} \setminus \{k\}} \left| \frac{\zeta_k - \zeta_j}{\zeta_k - \bar{\zeta}_j} \right| > 0.$$

Let us now consider the sequence $a\mathbb{Z}$ in \mathbb{S} with $a > 0$. With $b := e^{\frac{1}{2}\pi a}$ this corresponds to the sequence $\zeta_n = (ib^n)_{n \in \mathbb{Z}}$ in \mathbb{C}_+ . Then

$$\prod_{j \in \mathbb{Z} \setminus \{k\}} \left| \frac{\zeta_k - \zeta_j}{\zeta_k - \bar{\zeta}_j} \right| = \prod_{j \in \mathbb{Z} \setminus \{k\}} \left| \frac{b^k - b^j}{b^k + b^j} \right| = \prod_{n \neq 0} \left| \frac{b^n - 1}{b^n + 1} \right|.$$

Now

$$\delta := \prod_{n \leq -1} \left| \frac{b^n - 1}{b^n + 1} \right| = \prod_{n \geq 1} \left| \frac{b^n - 1}{b^n + 1} \right| = \prod_{n \geq 1} \left(1 - \frac{2}{b^n + 1} \right) > 0$$

since $\sum_{n \geq 1} \frac{2}{b^n + 1} < \infty$ (note that $b > 1$), and therefore Carleson's criterion is satisfied and we find the existence of $f \in H^\infty(\mathbb{C}_+)$ with $\|f\|_{H^\infty(\mathbb{C}_+)} \leq C\delta$. \square

H.2 Hardy spaces on a sector

As we have already observed, for $0 < \vartheta < \pi$ the function $z \mapsto \exp(z)$ maps the strip \mathbb{S}_ϑ bi-holomorphically onto the sector Σ_ϑ . Under this mapping, the lines $\{\Re z = r\}$ are mapped to the rays $\{\arg(z) = r\}$. Furthermore, the image measure of the Lebesgue measure dt on these lines is the measure dt/t along the rays. Either by using these observations or by redoing the proofs, most of the results proved in the preceding sections can be transferred to sectors.

Throughout the discussion we fix $0 < \vartheta < \pi$.

Definition H.2.1 (The Hardy spaces $H^p(\Sigma_\vartheta)$). For $1 \leq p \leq \infty$, $H^p(\Sigma_\vartheta)$ is the Banach space of all holomorphic functions $f : \Sigma_\vartheta \rightarrow \mathbb{C}$ for which

$$\|f\|_{H^p(\Sigma_\vartheta)} := \sup_{|\nu| < \vartheta} \|t \mapsto f(e^{i\nu}t)\|_{L^p(\mathbb{R}_+, \frac{dt}{t})} < \infty.$$

Remark H.2.2. A subtle point arises for $\vartheta = \frac{1}{2}\pi$: in that case $\mathbb{S}_{\frac{1}{2}\pi} = \mathbb{C}_+$ is the open right-half plane and the spaces $H^p(\mathbb{S}_{\frac{1}{2}\pi})$ introduced here should not be confused with the Hardy spaces obtained by imposing that

$$\sup_{s > 0} \|t \mapsto f(s + it)\|_{L^p(\mathbb{R})}$$

be finite.

We will need the sectorial versions of the results in the previous sections. For referencing purposes we document them here.

Proposition H.2.3. *Let $1 \leq p \leq \infty$. If $f \in H^p(\Sigma_\vartheta)$, then*

$$\sup_{t>0} \|n \mapsto f(2^n t)\|_{\ell^p(\mathbb{Z})} \leq K_\vartheta^{1/p} \|f\|_{H^p(\Sigma_\vartheta)},$$

where $K_\vartheta = \frac{4}{\pi \log(2)} \vee \frac{2}{\pi \vartheta}$.

Proof. Let $\vartheta' = \vartheta / \log(2)$ and define $g : \mathbb{S}_{\vartheta'} \rightarrow \mathbb{C}$ by $g(z) = f(2^z) = f(e^{z \log(2)})$. Fix $t > 0$ and $s = \log(t) / \log(2)$. Then by Proposition H.1.2

$$\begin{aligned} \sum_{n \in \mathbb{Z}} |f(2^n t)|^p &= \sum_{n \in \mathbb{Z}} |g(s + n)|^p \leq \left(\frac{4}{\pi} \vee \frac{2}{\pi \vartheta'}\right)^p \|g\|_{H^p(\mathbb{S}_{\vartheta'})}^p \\ &= K_\vartheta \log(2) \|g\|_{H^p(\mathbb{S}_{\vartheta'})}^p = K_\vartheta \|f\|_{H^p(\Sigma_\vartheta)}^p. \end{aligned}$$

□

Proposition H.2.4. *Let $1 \leq p \leq \infty$. If $f \in H^p(\Sigma_\vartheta)$, then for all $0 < \eta < \vartheta$ we have $f \in H^\infty(\Sigma_\eta)$ and*

$$\|f\|_{H^\infty(\Sigma_\eta)} \leq \left(\frac{2}{\pi(\vartheta - \eta)}\right)^{1/p} \|f\|_{H^p(\Sigma_\vartheta)}.$$

Proposition H.2.5. *Let $f \in H^1(\mathbb{S}_\vartheta)$. Then for all $0 < \eta < \vartheta$,*

$$\sup_{|y| \leq \eta} |f(re^{iy})| \rightarrow 0 \text{ as } r \rightarrow \infty \text{ or } r \downarrow 0.$$

Proposition H.2.6 (Three lines lemma, L^p -version for the sector). *Let $1 \leq p \leq \infty$. If $f \in H^p(\Sigma_\vartheta)$, then for all $-\vartheta < \nu < \sigma < \eta < \vartheta$ we have*

$$\|t \mapsto f(te^{i\sigma})\|_{L^p(\mathbb{R}_+, \frac{dt}{t})} \leq \|t \mapsto f(te^{i\nu})\|_{L^p(\mathbb{R}_+, \frac{dt}{t})}^{\frac{\sigma-\nu}{\eta-\nu}} \|t \mapsto f(te^{i\eta})\|_{L^p(\mathbb{R}_+, \frac{dt}{t})}^{\frac{\eta-\sigma}{\eta-\nu}}.$$

Proposition H.2.7 (Interpolating sequences for the sector). *For all real $b > 1$ and all $0 < \vartheta < \pi$ the sequence $(b^n)_{n \in \mathbb{Z}}$ is an interpolating sequence for Σ_ϑ . Moreover, there is a constant M_b such that for any given sequence $(c_n)_{n \in \mathbb{Z}} \in \ell^\infty(\mathbb{Z})$ an interpolating function can be found of norm*

$$\|f\|_{H^\infty(\Sigma_\vartheta)} \leq M_b \|c\|_{\ell^\infty(\mathbb{Z})}.$$

H.3 The Franks–McIntosh decomposition

We continue with a useful decomposition for vector-valued H^∞ -functions.

Theorem H.3.1 (Franks–McIntosh). *Given the angles $0 < \mu < \nu < \pi$, there exist sequences $(f_n)_{n \geq 1}, (g_n)_{n \geq 1}$ in $H^\infty(\Sigma_\mu)$ such that the following two assertions hold:*

(i) *for all $z \in \Sigma_\mu$ we have*

$$\sum_{n \geq 1} |f_n(z)| \leq 1 \quad \text{and} \quad \sum_{n \geq 1} |g_n(z)| \leq 1;$$

(ii) *every function $F \in H^\infty(\Sigma_\nu; X)$, where X is any Banach space, can be represented on Σ_μ as a pointwise convergent sum*

$$F(z) = \sum_{n \geq 1} f_n(z)g_n(z)x_n, \quad z \in \Sigma_\mu,$$

with coefficients $x_n \in X$ satisfying

$$\sup_{n \geq 1} \|x_n\| \lesssim_{\mu, \nu} \|F\|_{H^\infty(\Sigma_\nu; X)}.$$

For the proof of this theorem we need to introduce some notation. Choose $\rho > 1$ so that

$$\rho - 1 = \frac{1}{2} \text{dist}(e^{i\beta}, \Sigma_\mu) = \frac{1}{2} \sin\left(\frac{1}{2}(\nu - \mu)\right), \tag{H.1}$$

where $\beta := \frac{1}{2}(\mu + \nu)$. See Figure (H.1). For $k \in \mathbb{Z}$ we define the line segments I_k^+ and I_k^- by

$$I_k^\pm := \{r e^{\pm i\beta} : \rho^k \leq r \leq \rho^{k+1}\}.$$

The union of these segments is $\partial\Sigma_\beta \setminus \{0\}$. For $\sigma \in \{+, -\}$ let $(e_{j,0}^\sigma)_{j \geq 0}$ be the orthonormal basis for $L^2(I_0^\sigma, |dz|/|z|)$ obtained by a Gram–Schmidt orthogonalisation procedure applied to the sequence $(z^j)_{j \geq 0}$. Thus each $e_{j,0}^\sigma$ is a polynomial of degree j which satisfies

$$\int_{I_0^\sigma} z^l e_{j,0}^\sigma(z) \frac{|dz|}{|z|} = 0, \quad l = 0, 1, \dots, j - 1. \tag{H.2}$$

For $z \in I_k^\sigma$ and $k \in \mathbb{Z}$ set

$$e_{j,k}^\sigma(z) := e_{j,0}^\sigma(\rho^{-k}z). \tag{H.3}$$

Then $(e_{j,k}^\sigma)_{j \geq 0}$ is an orthonormal basis for $L^2(I_k^\sigma, |dz|/|z|)$. Extending these functions identically zero on $\Sigma_\beta \setminus I_k^\sigma$, we obtain an orthonormal basis for $L^2(\partial\Sigma_\beta, |dz|/|z|)$.

For $z, \zeta \in \Sigma_\beta, z \neq \zeta$, set

$$K(z, \zeta) := \frac{z^{1/2} \zeta^{1/2}}{z - \zeta}. \tag{H.4}$$

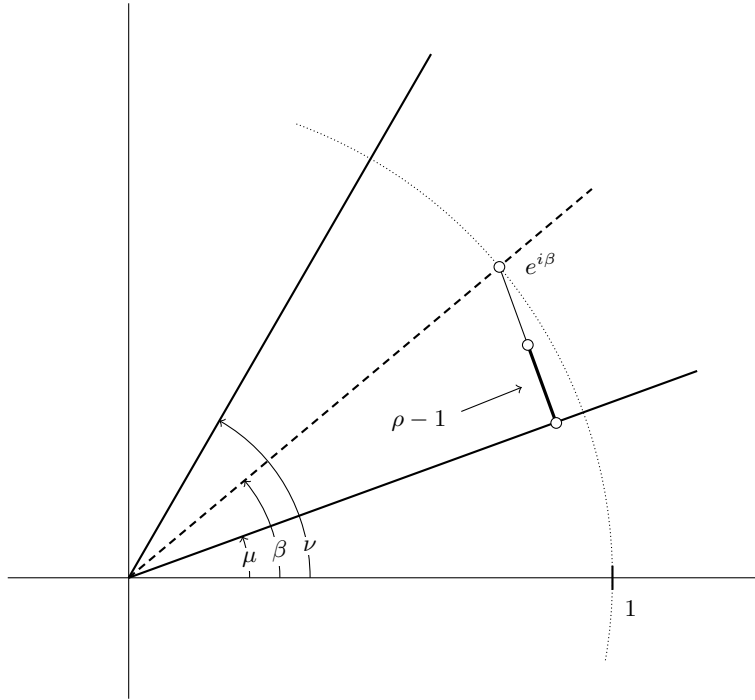

Fig. H.1: The definition of ρ

By Cauchy’s theorem, for all $g \in H^\infty(\Sigma_\beta)$ and $|\arg(\zeta)| < \beta' < \beta$ we have

$$g(\zeta) = \zeta^{1/2} \cdot \frac{1}{2\pi i} \int_{\partial\Sigma_{\beta'}} \frac{z^{-1/2}g(z)}{z - \zeta} dz = \frac{1}{2\pi i} \int_{\partial\Sigma_{\beta'}} g(z)K(z, \zeta) \frac{dz}{z}. \tag{H.5}$$

Motivated by this formula we define the holomorphic functions $\Phi_{j,k}^\sigma : \Sigma_\beta \rightarrow \mathbb{C}$,

$$\Phi_{j,k}^\sigma(\zeta) := \frac{1}{2\pi i} \int_{\partial\Sigma_{\beta'}} e_{j,k}^\sigma(z)K(z, \zeta) \frac{dz}{z}, \tag{H.6}$$

where $\beta' = \beta'(\zeta)$ is as before. By (H.3),

$$\Phi_{j,k}^\sigma(\zeta) = \Phi_{j,0}^\sigma(\rho^{-k}\zeta), \quad \eta \in \Sigma_\beta.$$

For these functions we have the following decay estimate.

Lemma H.3.2. *There is a constant $C \geq 0$, depending only on ρ , such that if $\zeta \in \Sigma_\mu$ and $n \in \mathbb{Z}$ are such that $\rho^n < |\zeta| \leq \rho^{n+1}$, then*

$$|\Phi_{j,k}^\sigma(\zeta)| \leq C\rho^{-\frac{1}{2}|k-n|}2^{-j}, \quad \sigma \in \{+, -\}, \quad j \geq 0, \quad k \in \mathbb{Z}.$$

As a consequence, for all $p > 0$ there is a constant c_p such that

$$\sup_{\zeta \in \Sigma_\mu} \sum_{\sigma \in \{+, -\}} \sum_{j \geq 0} \sum_{k \in \mathbb{Z}} |\Phi_{j,k}^\sigma(\zeta)|^p \leq c_p.$$

Proof. Fix $\zeta \in \Sigma_\mu$ and let $n \in \mathbb{Z}$ be such that $\rho^n < |\zeta| \leq \rho^{n+1}$. Let B_k^σ denote the ball of radius $\rho^{k+1} - \rho^k$ centred at $z_k^\sigma := \frac{1}{2}(\rho^{k+1} - \rho^k)e^{\sigma i\beta}$. By (H.1) this ball does not intersect Σ_μ or $\partial\Sigma_\nu$.

Suppose $z \in B_k^\sigma$. Using (H.4) and (H.1) we see the following (see Figure H.2):

- if $n \geq k + 2$, then $|z - \zeta| \geq \rho^n - \rho^{k+1} \geq \rho^{n-1}(\rho - 1)$;
- if $k - 1 \leq n \leq k + 1$, then $|z - \zeta| \geq \rho^k - \rho^{k-1} = \rho^{k-1}(\rho - 1)$;
- if $n \leq k - 2$, then $|z - \zeta| \geq \rho^k - \rho^{n+1} \geq \rho^k - \rho^{k-1} \geq \rho^{k-1}(\rho - 1)$.

In all three cases we have $|z - \zeta| \geq \rho^{\max\{n,k\}}\rho^{-2}(\rho - 1)$. As a consequence,

$$\begin{aligned} \sup_{z \in B_k^\sigma} |K(z, \zeta)| &= \sup_{z \in B_k^\sigma} \left| \frac{z^{1/2}\zeta^{1/2}}{z - \zeta} \right| \\ &\leq \rho^2(\rho - 1)^{-1}\rho^{-\max\{k,n\}} \sup_{z \in B_k^\sigma} |z^{1/2}\zeta^{1/2}| \\ &\leq \rho^2(\rho - 1)^{-1}\rho^{-\max\{k,n\}}\rho^{(k+1)/2}\rho^{(n+1)/2} = c\rho^{-|k-n|/2}, \end{aligned}$$

where $c = \rho^3(\rho - 1)^{-1}$ only depends on ρ (and hence on μ and ν). Let

$$K(z, \zeta) = \sum_{m \geq 0} b_{m,k}^\sigma(\zeta) \left(\frac{z - z_k^\sigma}{\rho^{k+1} - \rho^k} \right)^m$$

be the power series of $K(\cdot, \zeta)$ on B_k^σ in the variable $(z - z_k^\sigma)/(\rho^{k+1} - \rho^k)$. Then

$$\left(\sum_{m \geq 0} |b_{m,k}^\sigma(\zeta)|^2 \right)^{1/2} = \left(\int_{\partial B_k^\sigma} |K(z, \zeta)|^2 \frac{|dz|}{2\pi(\rho^{k+1} - \rho^k)} \right)^{1/2} \leq c\rho^{-\frac{1}{2}|k-n|}.$$

The interval I_k^σ is contained in a closed ball of half the radius of B_k^σ . Thus, by the Cauchy–Schwarz inequality, for $z \in I_k^\sigma$ and $j \in \mathbb{Z}$ we obtain

$$\begin{aligned} \sum_{m=j}^\infty \left| b_{m,k}^\sigma(\zeta) \left(\frac{z - z_k^\sigma}{\rho^{k+1} - \rho^k} \right)^m \right| &\leq \left(\sum_{m=j}^\infty |b_{m,k}^\sigma(\zeta)|^2 \right)^{1/2} \left(\sum_{m=j}^\infty \frac{1}{2^{2m}} \right)^{1/2} \\ &\leq c\rho^{-\frac{1}{2}|k-n|} 2^{-j+\frac{1}{2}}. \end{aligned}$$

Finally, by (H.2), $e_{j,k}^\sigma$ is orthogonal to $(z - z_k^\sigma)^l$ for $0 \leq l \leq j - 1$, and since $e_{j,k}^\sigma$ is supported in I_k^σ we obtain

$$|\Phi_{j,k}^\sigma(\zeta)| = \left| \frac{1}{2\pi i} \int_{\partial\Sigma_\beta} e_{j,k}^\sigma(z) K(z, \zeta) \frac{dz}{z} \right|$$

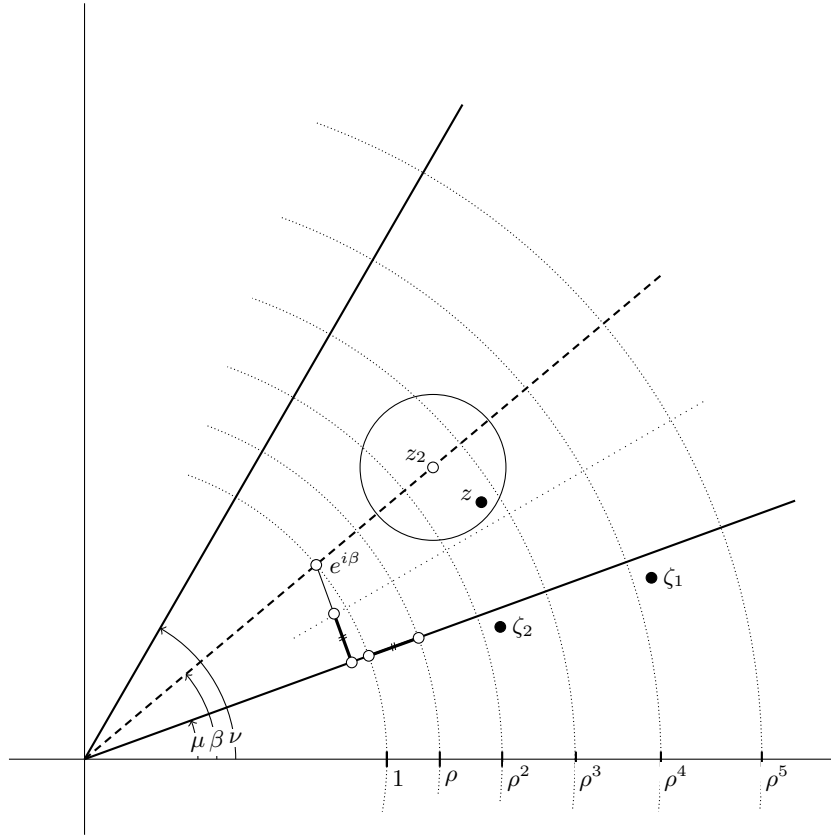

Fig. H.2: $|z - \zeta| \geq \rho^n - \rho^{k+1}$ for $n \geq k + 2$ and $|z - \zeta| \geq \rho^k - \rho^{k-1}$ for $k - 1 \leq n \leq k + 1$.

$$\begin{aligned}
 &= \left| \frac{1}{2\pi i} \int_{I_k^\sigma} e_{j,k}^\sigma(z) \sum_{m=j}^\infty b_{m,k}^\sigma(\zeta) \left(\frac{z - z_k^\sigma}{\rho^{k+1} - \rho^k} \right)^m \frac{dz}{z} \right| \\
 &\leq \frac{1}{2\pi} \int_{I_k^\sigma} |e_{j,k}^\sigma(z)| \sum_{m=j}^\infty |b_{m,k}^\sigma(\zeta)| \left(\frac{z - z_k^\sigma}{\rho^{k+1} - \rho^k} \right)^m \left| \frac{dz}{z} \right| \\
 &\leq \frac{\log^{1/2}(\rho)}{2\pi} c \rho^{-\frac{1}{2}|k-n|} 2^{-j+\frac{1}{2}}.
 \end{aligned}$$

□

Proof of Theorem H.3.1. Fix $F \in H^\infty(\Sigma_\nu; X)$.

Step 1 – In this step we show that F can be represented as

$$F(\zeta) = \sum_{\sigma \in \{+, -\}} \sum_{j \geq 0} \sum_{k \in \mathbb{Z}} \Phi_{j,k}^\sigma \otimes x_{j,k}^\sigma, \quad \zeta \in \Sigma_\mu, \tag{H.7}$$

where

$$x_{j,k}^\sigma := \int_{I_k^\sigma} F(z) \overline{e_{j,k}^\sigma(z)} \frac{|dz|}{|z|}.$$

We begin by noting that

$$\|x_{j,k}^\sigma\|^2 \leq \int_{I_k^\sigma} |F(z)|^2 \frac{|dz|}{|z|} \leq \log(\rho) \|F\|_{H^\infty(\Sigma_\nu)}^2.$$

For fixed $\zeta \in \Sigma_\mu$ we have $K(\cdot, \zeta) \in L^1(\partial\Sigma_\beta, |dz|/|z|)$, and (H.5) and (H.6) give

$$\begin{aligned} F(\zeta) &= \lim_{n \rightarrow \infty} \sum_{\sigma \in \{+, -\}} \sum_{|k| \leq n} \int_{I_k^\sigma} F(z) K(z, \zeta) \frac{|dz|}{|z|} \\ &= \lim_{n \rightarrow \infty} \sum_{\sigma \in \{+, -\}} \sum_{|k| \leq n} \int_{I_k^\sigma} \sum_j e_{j,k}^\sigma(z) (z) K(z, \zeta) x_{j,k}^\sigma \frac{|dz|}{|z|} \\ &= \lim_{n \rightarrow \infty} \sum_{\sigma \in \{+, -\}} \sum_{|k| \leq n} \Phi_{j,k}^\sigma(\zeta) x_{j,k}^\sigma \\ &= \sum_{\sigma \in \{+, -\}} \sum_{j \geq 0} \sum_{k \in \mathbb{Z}} \Phi_{j,k}^\sigma \otimes x_{j,k}^\sigma, \end{aligned}$$

using Lemma H.3.2 to justify the convergence in the last step. This completes the proof of (H.7).

Step 2 – We now derive the decomposition of the theorem from the representation given in Step 1. First, $(\Phi_n)_{n \geq 1}$ and $(x_n)_{n \geq 1}$ be compatible enumerations of the countable families $\Phi_{j,k}^\sigma$ and $x_{j,k}^\sigma$, so that (H.7) takes the form

$$F(\zeta) = \sum_{n \geq 1} \Phi_n(\zeta) \otimes x_n.$$

Next, let $\Theta(z) := (\frac{1-z}{1+z})^{2\mu/\pi}$ be a bi-holomorphic mapping of the unit disk \mathbb{D} onto Σ_μ , and note that it is also a continuous bijection of $\overline{\mathbb{D}} \setminus \{-1, +1\}$ onto $\overline{\Sigma_\mu} \setminus \{0\}$. Then each $\phi_n := \Phi_n \circ \Theta$ belongs to $H^\infty(\mathbb{D})$ and thereby has an inner-outer factorisation $\phi_n = \iota_n \omega_n$, where the inner function ι_n has radial limits $|\iota_n(z)| = 1$ for $z \in \partial\mathbb{D}$, while the outer function ω_n has a holomorphic root $\sqrt{\omega_n} \in H^\infty(\mathbb{D})$, which can be represented as the Poisson integral of its radial boundary values on $\partial\mathbb{D}$:

$$\sqrt{\omega_n(z)} = \frac{1}{2\pi} \int_{-\pi}^\pi P(z, e^{it}) \sqrt{\omega_n(e^{it})} dt,$$

where the Poisson kernel P satisfies $P \geq 1$ and $\frac{1}{2\pi} \int_{-\pi}^\pi P(z, e^{it}) dt = 1$ for all $z \in \mathbb{D}$.

Since $|\phi_n(z)| = |\iota_n(z)\omega_n(z)| = |\omega_n(z)|$ for $z \in \partial\mathbb{D}$, we have

$$\begin{aligned} \sum_{n \geq 1} |\sqrt{\omega_n(z)}| &\leq \frac{1}{2\pi} \int_{-\pi}^{\pi} P(z, e^{it}) \sum_{n \geq 1} |\phi_n(e^{it})|^{1/2} dt \\ &= \frac{1}{2\pi} \int_{-\pi}^{\pi} P(z, e^{it}) \sum_{n \geq 1} |\Phi_n(\Theta(e^{it}))|^{1/2} dt \\ &\leq \frac{1}{2\pi} \int_{-\pi}^{\pi} P(z, e^{it}) c_{1/2} dt = c_{1/2}, \end{aligned}$$

where $c_{1/2}$ is the constant from Lemma H.3.2 when $p = 1/2$; we used this lemma at $\zeta = \Theta(e^{it}) \in \partial\Sigma_\mu$, noting that the functions Φ_n , an enumeration of the $\Phi_{j,k}^\sigma$, are holomorphic in a bigger sector; hence in particular continuous up to the boundary $\partial\Sigma_\mu$.

Now it remains to set $f_n := c_{1/2}^{-1}(\iota_n\omega_n^{1/2}) \circ \Theta^{-1}$ and $g_n := c_{1/2}^{-1}\omega_n^{1/2} \circ \Theta^{-1}$. Since the inner function satisfies $|\iota_n(z)| \leq 1$, we have

$$\sum_{n \geq 1} |f_n(\zeta)| \leq \sum_{n \geq 1} |g_n(\zeta)| = c_{1/2}^{-1} \sum_{n \geq 1} |\sqrt{\omega_n(\Theta^{-1}(\zeta))}| \leq 1,$$

whereas

$$\begin{aligned} \sum_{n \geq 1} f_n(\zeta)g_n(\zeta)x_n &= \sum_{n \geq 1} c_{1/2}^{-2}(\iota_n\omega_n)(\Theta^{-1}\zeta)x_n = c_{1/2}^{-2} \sum_{n \geq 1} \phi_n(\Theta^{-1}\zeta)x_n \\ &= c_{1/2}^{-2} \sum_{n \geq 1} \Phi_n(\Theta^{-1}\zeta)x_n = c_{1/2}^{-2}F(\zeta). \end{aligned}$$

Replacing x_n by $c_{1/2}^2x_n$, we obtain the claimed representation of $F(\zeta)$ for all $\zeta \in \Sigma_\mu$. □

H.4 Notes

Excellent treatments of Hardy spaces include [Duren \[1970\]](#), [Garnett \[2007\]](#), and [Hoffman \[1962\]](#). These references also contain proofs of Carleson’s criterion used in the proof of Proposition H.1.6.

Section H.1

Hardy spaces on a strip can be defined in various non-equivalent ways. Besides the approach taken here, one could alternatively map the unit disc bi-holomorphically onto the strip $\mathbb{S}_1 = \{|\Im z| < 1\}$ by means on the conformal mapping $\psi : \mathbb{S}_1 \rightarrow \mathbb{D}$, $\psi(z) = \tanh(\frac{1}{4}\pi z)$, and then introduce the norm

$$\|f\|_{\tilde{H}^p(\mathbb{S}_1)} := \|f \circ \psi^{-1}\|_{H^p(\mathbb{D})}$$

where

$$\|g\|_{H^p(\mathbb{D})} = \sup_{0 < r < 1} \|\theta \mapsto g(re^{i\theta})\|_{L^p(\mathbb{T})}.$$

The case of a general strip can be handled similarly. The relation between the spaces $H^p(\mathbb{S}_1)$ and $\tilde{H}^p(\mathbb{S}_1)$ is studied in detail in [Bakan and Kaijser \[2007\]](#), where it is shown that for $1 \leq p < \infty$, a holomorphic function $f : \mathbb{S}_1 \rightarrow \mathbb{C}$ belongs to $H^p(\mathbb{S}_1)$ if and only if the function $w^{1/p}f$ belongs to $\tilde{H}^p(\mathbb{S}_1)$, where $w(z) = \cosh^2(\frac{1}{4}\pi z)$, and this correspondence sets up an isomorphism of Banach spaces.

Section H.2

Hardy spaces on the half-plane based on the norm mentioned in [Remark H.2.2](#) are studied in detail in [Hoffman \[1962\]](#).

Section H.3

[Theorem H.3.1](#) and its proof are taken from [Franks and McIntosh \[1998\]](#). More on the inner-outer factorisation used in the proof can be found in [Rudin \[1987, Chapter 17\]](#).

Akcoglu's theory of positive contractions on L^p

This appendix reviews some classical results on positive contractions $T \in \mathcal{L}(L^p(S))$ which play a role in establishing the boundedness of the H^∞ -functional calculus of several classes of sectorial operators in Chapter 10. Our discussion is tailored for the needs of these applications and splits into two topics: dilation theory and a maximal ergodic theorem.

I.1 Isometric dilations

The main object of interest in this section is defined as follows:

Definition I.1.1 (Dilations). *Let X and Y be Banach spaces and $T \in \mathcal{L}(X)$ and $U \in \mathcal{L}(Y)$. Then U is called a dilation of T if there exist an isometric embedding $J : X \rightarrow Y$ and a contractive projection P in Y onto $R(J)$ such that*

$$JT^k = PU^k J, \quad \text{for all } k = 0, 1, 2, \dots$$

The equation can also be expressed by saying that the following 'diagram commutes':

$$\begin{array}{ccc} X & \xrightarrow{T^k} & X \\ J \downarrow & & \uparrow J^{-1}P \\ Y & \xrightarrow{U^k} & Y \end{array}$$

Obviously, T itself is its own dilation with $Y = X$ and $J = P = I_X$. The main interest in dilations is that they may be required to possess additional properties compared to the original operator T . The following main result of this section is a prime example of this phenomenon: clearly being an invertible isometry is a much stronger property than just being contractive. While the class of finite-dimensional spaces ℓ_n^p -spaces considered in the theorem might appear somewhat restricted at first, it provides a good model for general L^p -spaces by means of approximation arguments.

Theorem I.1.2 (Akcoglu–Sucheston). *Let T be a positive contraction on ℓ_n^p , where $1 < p < \infty$ and $n \in \mathbb{Z}_+$. Then T has a dilation $U \in \mathcal{L}(L^p(D))$ on some measurable subset $D \subseteq \mathbb{R}^2$, such that U is a positive invertible isometry.*

Here we think of D as a measure space equipped with the Lebesgue measure inherited from \mathbb{R}^2 by restriction.

Theorem I.1.2 is a special case of a more general Akcoglu–Sucheston theorem, which asserts that every positive contraction on a space $L^p(S)$ has a positive isometric dilation to a space $L^p(T)$, for some measure space (T, \mathcal{B}, ν) . This result can be deduced from Theorem I.1.2 using ultrapower techniques. Since we will not need this more general version, we defer a discussion of it to the Notes at the end of the chapter.

Before turning to the proof of Theorem I.1.2 we note that it suffices to prove the theorem for the case where all spaces are real. Indeed, if T is a positive contraction on the space $\ell_n^p(\mathbb{C}) = \ell^p(\{1, 2, \dots, n\}; \mathbb{C})$, then it restricts to a positive contraction on its real subspace $\ell_n^p(\mathbb{R}) = \ell^p(\{1, 2, \dots, n\}; \mathbb{R})$. Let us denote this restriction by $T^{\mathbb{R}}$. If U is a positive isometric extension of $T^{\mathbb{R}}$ to the real space $L^p(D; \mathbb{R})$ for some measurable set $D \subseteq \mathbb{R}^2$, then its complexification $U_{\mathbb{C}}$ provides the desired isometric extension of $T = (T^{\mathbb{R}})_{\mathbb{C}}$ (all steps in this procedure are isometric; cf. Section B.4).

Thanks to this reduction we may, and shall, assume that all spaces are real. We fix the exponent $1 < p < \infty$ and assume that T is a positive contraction on the space $E := \ell_n^p$. The dual space of E will be denoted by $E^* = (\ell_n^p)^* = \ell_n^{p'}$, and the positive cones in E and E^* will be denoted by E_+ and E_+^* , respectively.

We will treat the vectors $x \in E$ as functions $x : \{1, \dots, n\} \rightarrow \mathbb{R}$ and, accordingly, interpret all usual algebra like exponentiation and inequalities in the pointwise (component-wise) sense. In particular, for $x \in E_+$, the vector $x^{p-1} \in E_+^*$ satisfies

$$\|x\|_p^p = \|x^{p-1}\|_{p'}^{p'} = \langle x, x^{p-1} \rangle \tag{I.1}$$

We define the (non-linear) mapping $M_T : E_+ \rightarrow E_+^*$ by

$$M_T x := T^*((Tx)^{p-1}).$$

Our first aim is to establish the following:

Lemma I.1.3. *There exists a vector $x \in E_+$ with strictly positive coordinates such that*

$$M_T x \leq x^{p-1}.$$

The proof of the lemma proceeds in several steps.

Lemma I.1.4. *If $x \in E_+$ satisfies $\|Tx\|_p = \|T\|\|x\|_p$, then*

$$M_T x = \|T\|^p x^{p-1}.$$

Proof. By (I.1) we have

$$\|M_T x\|_{p'} \leq \|T^*\| \|(Tx)^{p-1}\|_{p'} = \|T\| \|Tx\|_p^{p-1} = \|T\|^p \|x\|_p^{p-1}.$$

Also, by Hölder's inequality,

$$\|x\|_p \|M_T x\|_{p'} \geq \langle x, M_T x \rangle = \langle Tx, (Tx)^{p-1} \rangle = \|Tx\|_p^p = \|T\|^p \|x\|_p^p.$$

Combining these inequalities we find that $\|M_T x\|_{p'} = \|T\|^p \|x\|_p^{p-1}$, which means that we had equality throughout. In particular we have equality in Hölder's inequality, i.e., $\|x\|_p \|M_T x\|_{p'} = \langle x, M_T x \rangle$. This is only possible if $M_T x = \lambda x^{p-1}$ for some constant $\lambda \geq 0$. But then $\langle x, \lambda x^{p-1} \rangle = \|T\|^p \|x\|_p^p$ shows that $\lambda = \|T\|^p$. \square

For any subset I of $\{1, \dots, n\}$ we denote by T_I the positive contraction on E defined by

$$T_I x := T(\mathbf{1}_I x), \quad x \in E.$$

The *support* of an element $x \in E$ is defined as $\text{supp}(x) := \{i \in \{1, \dots, n\} : x_i \neq 0\}$. For subsets $I \subseteq \{1, \dots, n\}$ let

$$E_I = \{x \in E : \text{supp}(x) \subseteq I\}$$

be the subspace of elements with support contained in I . By $E_+(I) = \{x \in E_I : x \geq 0\}$ we denote its positive cone. It is immediate to check that the adjoint of T_I is given by $T_I^* = \mathbf{1}_I T^*$.

Lemma I.1.5. *If $x \in E_+(I)$ satisfies $\|Tx\|_p = \|T_I\| \|x\|_p$, then*

$$\mathbf{1}_I M_T x = \|T_I\|^p x^{p-1}.$$

Proof. By the previous lemma applied to T_I ,

$$\mathbf{1}_I M_T x = \mathbf{1}_I T^* (Tx)^{p-1} = T_I^* (Tx)^{p-1} = T_I^* (T_I x)^{p-1} = M_{T_I} x = \|T_I\|^p x^{p-1}.$$

\square

Lemma I.1.6. *Let $x, y \in E_+$ have disjoint supports. If $M_T x \leq x^{p-1}$, then the supports of x and $M_T y$ are disjoint and $M_T(x + y) = M_T x + M_T y$.*

Proof. Using the positivity of T and assumptions we have $0 \leq \langle Ty, (Tx)^{p-1} \rangle = \langle y, M_T x \rangle \leq \langle y, x^{p-1} \rangle = 0$. It follows that $\langle Ty, (Tx)^{p-1} \rangle = 0$. Therefore Ty and $(Tx)^{p-1}$ must have disjoint supports, and this implies that Ty and Tx have disjoint supports. But then $0 = \langle Tx, (Ty)^{p-1} \rangle = \langle x, M_T y \rangle$, from which we infer that x and $M_T y$ have disjoint supports.

Using again that Tx and Ty have disjoint supports, we find that $(T(x + y))^{p-1} = (Tx)^{p-1} + (Ty)^{p-1}$. Applying T^* to both sides of this identity gives $M_T(x + y) = M_T x + M_T y$. \square

The attentive reader will have noticed that, in the preceding lemmas, the role of $E = \ell_n^p$ could be taken over by any L^p -space, provided we replace I by a general measurable set. In the next proof, however, the finite-dimensionality of ℓ_n^p is decisive:

Proof of Lemma I.1.3. We claim that if $x \in E_+$ has support strictly contained in $\{1, \dots, n\}$ and satisfies $M_T x \leq x^{p-1}$, then there exists $x' \in E_+$ with support strictly larger than the support of x and satisfying $M_T x' \leq (x')^{p-1}$.

Once we have convinced ourselves of the truth of this claim, we may prove the lemma by starting with $x = 0$ and repeatedly applying the claim until we arrive, in finitely many steps, at a positive element $x \in E_+$ of full support satisfying $M_T x \leq x^{p-1}$.

To prove the claim let $x \in E_+$ have support I strictly contained in $\{1, \dots, n\}$ and satisfy $M_T x \leq x^{p-1}$. Let $J := \mathbb{C}I$. Since E_J is non-zero and finite-dimensional there exists $y \in E_J$ such that $\|y\| = 1$ and

$$\|Ty\| = \|T_J y\| = \|T_J\|.$$

Therefore by Lemma I.1.5 and the contractivity of T_J ,

$$\mathbf{1}_J M_T y = \|T_J\|^p y^{p-1} \leq y^{p-1}.$$

Since by assumption $M_T x \leq x^{p-1}$, by Lemma I.1.6 the supports of x and $M_T y$ are disjoint and we have $M_T(x + y) = M_T x + M_T y$. Since the support of x equals I , the disjointness of x and $M_T y$ implies that the support of $M_T y$ is contained in J , so $\mathbf{1}_J M_T y = M_T y$. Then the latter implies

$$M_T(x + y) = M_T x + M_T y = M_T x + \mathbf{1}_J M_T y \leq x^{p-1} + y^{p-1} = (x + y)^{p-1},$$

where we used that the supports of x and y are disjoint. The element $x + y$ has the desired properties. \square

We are now ready for:

Proof of Theorem I.1.2. As before we write $E = \ell_n^p$. By Lemma I.1.3 there exists a vector $x \in E_+$, with all coordinates strictly positive, satisfying $M_T x \leq x^{p-1}$. Let $y := Tx$. Let

$$I := \{1, \dots, n\} \quad \text{and} \quad J := \{j \in I : y_j \neq 0\} \tag{I.2}$$

be the supports of x and y , respectively. Representing $T = (t_{ij})_{i,j=1}^n$ as a matrix with respect to the standard basis of E , we set

$$\begin{aligned} \xi_{ij} &:= t_{ji} \frac{x_i}{y_j}, & (i, j) \in I \times J, \\ \eta_{ij} &:= t_{ji} \left(\frac{y_j}{x_i}\right)^{p-1}, & (i, j) \in I \times I. \end{aligned}$$

Then for all $j \in J$ we have

$$\sum_{i=1}^n \xi_{ij} = \frac{1}{y_j} \sum_{i=1}^n t_{ji} x_i = \frac{(Tx)_j}{y_j} = \frac{y_j}{y_j} = 1$$

and similarly, for all $i \in I$,

$$\begin{aligned} \sum_{j \in J} \eta_{ij} &= \sum_{j=1}^n \eta_{ij} = \frac{1}{x_i^{p-1}} \sum_{j=1}^n t_{ji} (Tx)_j^{p-1} \\ &= \frac{(T^*(Tx)^{p-1})_i}{x_i^{p-1}} = \frac{(M_T x)_i}{x_i^{p-1}} \leq \frac{x_i^{p-1}}{x_i^{p-1}} = 1. \end{aligned} \tag{I.3}$$

We will now describe the construction of the new measure space, which will arise as a union of (axes-parallel) rectangles in \mathbb{R}^2 . We say that subsets of $A, B \subseteq \mathbb{R}^2$ are *strongly disjoint* if their projections into both coordinate axes are disjoint, i.e., if $(x, y) \in A$, then $\{x\} \times \mathbb{R}$ and $\mathbb{R} \times \{y\}$ are both disjoint from B .

We choose disjoint intervals $I_i, i \in I$, of length one and set $N_i := I_i \times I_i$; these are strongly disjoint. For each $i \in I$, we choose disjoint subintervals $J_{ij} \subseteq I_i, j \in J$, of length η_{ij} , and denote

$$J_i := \bigcup_{j \in J} J_{ij} \subseteq I_i, \quad |J_i| = \sum_{j \in J} |J_{ij}| \sum_{j \in J} \eta_{ij} = \sum_{j=1}^n \eta_{ij} \leq 1.$$

Also, for each $j \in J$ we partition

$$I_j = \bigcup_{i \in I} I_{ij}, \quad |I_{ij}| = \xi_{ij}.$$

For $(i, j) \in I \times J$ we now set

$$N_i := I_i \times I_i, \quad R_{ij} := I_i \times J_{ij} \subseteq I_i \times J_i \subseteq N_i, \quad S_{ij} := I_{ij} \times I_j \subseteq N_j$$

and

$$R := \bigcup_{(i,j) \in I \times J} R_{ij} = \bigcup_{i \in I} I_i \times J_i, \quad S := \bigcup_{(i,j) \in I \times J} S_{ij} = \bigcup_{j \in J} N_j.$$

Let further $D_0 := \bigcup_{i=1}^n N_i$ and observe that

$$D_0 \setminus R = \bigcup_{i \in I} I_i \times (I_i \setminus J_i), \quad D_0 \setminus S = \bigcup_{i \in I \setminus J_i} N_i$$

are certain unions of rectangles. We then define $D_k, k \geq 1$, to consist of strongly disjoint translates of $D_0 \setminus R$, and $D_k, k \leq -1$, to consist of strongly disjoint translates of $D_0 \setminus S$. Let finally $D := \bigcup_{k \in \mathbb{Z}} D_k$.

Given two rectangles $A = A_1 \times A_2, B = B_1 \times B_2 \subseteq \mathbb{R}^2$, we define the *special affine transform* of A onto B as the unique $\tau : A \rightarrow B$ of the form $\tau(u, v) = (\tau_1(u), \tau_2(v))$, where $\tau_i(t) = a_{i1}t + a_{i2}$ is the unique increasing affine bijection of the interval $A_i \subseteq \mathbb{R}$ onto the interval $B_i \subseteq \mathbb{R}$ for both $i = 1, 2$. While this precise form of τ is somewhat irrelevant, it is important for later considerations that we choose our mapping to act independently in the first and the second coordinate.

We next construct a bijection of D onto itself.

Step 1 (action on R) – We define $\tau : R \rightarrow S$ by $\tau = \tau_{ij}$ on R_{ij} , where τ_{ij} is the special affine transform of R_{ij} onto S_{ij} .

Step 2 (action on $D_0 \setminus R$ and $\bigcup_{k \geq 1} D_k$) – If $R = D_0$, then we define τ as the identity mapping on $\bigcup_{k \geq 1} D_k$; otherwise we define τ to be the translation of $D_0 \setminus R$ onto D_1 , and of D_k onto D_{k+1} for each $k \geq 1$.

Step 3 (action on $\bigcup_{k \geq 1} D_{-k}$) – If $S = D_0$, then define τ as the identity mapping on $\bigcup_{k \geq 1} D_{-k}$; otherwise we define τ to be the translation of D_{-1} onto $D_0 \setminus S$, and of D_{-k-1} onto D_{-k} for $k \geq 1$.

On D we consider the image measure $\mu := \lambda \circ \tau^{-1}$, where λ is the restriction of the Lebesgue measure to D . The measure μ is absolutely continuous with respect to λ . Denoting the Radon–Nikodým derivative of μ with respect to λ by ρ , for $(i, j) \in I \times J$ and $(u, v) \in S_{ij}$ we have

$$\rho(u, v) = \frac{d\mu}{d\lambda}(u, v) = \frac{\lambda(\tau^{-1}(S_{ij}))}{\lambda(S_{ij})} = \frac{\lambda(R_{ij})}{\lambda(S_{ij})} = \frac{\eta_{ij}}{\xi_{ij}} = \frac{t_{ji}(\frac{y_j}{x_j})^{p-1}}{t_{ji}(\frac{x_i}{y_j})} = \left(\frac{y_j}{x_i}\right)^p.$$

Consider the positive operator $U : f \mapsto Uf$ defined by

$$Uf(u, v) := \rho(u, v)^{1/p} f(\tau^{-1}(u, v)), \quad (u, v) \in D.$$

This operator is an invertible isometry of $L^p(D, \lambda)$: invertibility is clear and it is an isometry since

$$\begin{aligned} \int_D |Uf|^p d\lambda &= \int_D \rho |f \circ \tau^{-1}|^p d\lambda \\ &= \int_D |f \circ \tau^{-1}|^p d(\lambda \circ \tau^{-1}) = \int_D |f|^p d\lambda. \end{aligned}$$

To conclude the proof of Theorem I.1.2 we will now show that U is a positive isometric dilation of T . More precisely, we will show that

$$HT^k = PU^k H, \quad k = 0, 1, \dots, \tag{I.4}$$

where $H : E \rightarrow L^p(D, \lambda)$ is the isometric embedding given by

$$H\xi = \sum_{i=1}^n \xi_i \mathbf{1}_{N_i}, \quad \xi \in E = \ell_n^p,$$

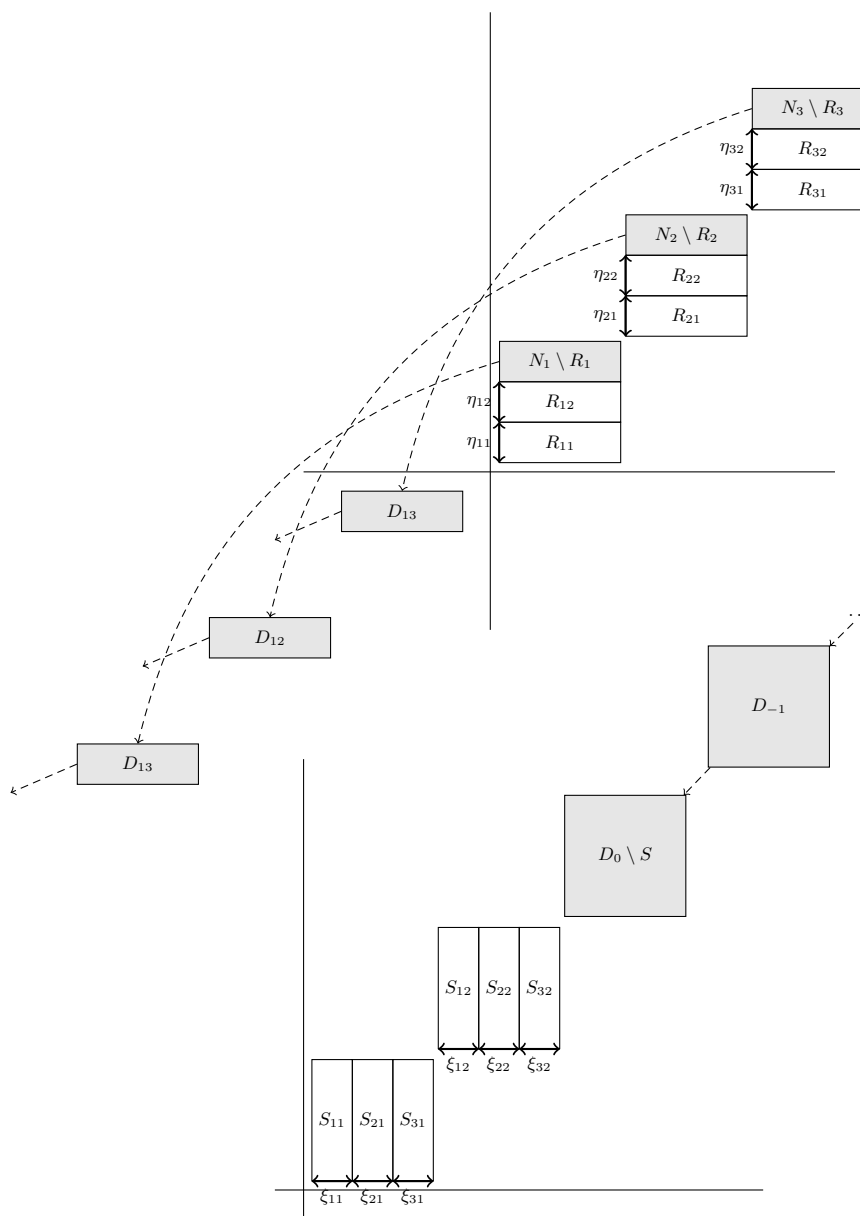

Fig. I.1: The case $I = \{1, 2, 3\}$ and $J = \{1, 2\}$. The action of τ is indicated with dashed arrows. The rectangles R_{ij} are mapped on S_{ij} ; $D_0 \setminus R = \bigcup_{i=1}^3 N_i \setminus R_i$ is mapped to $D_1 = \bigcup_{i=1}^3 D_{1i}$; D_1 to D_2 ; D_{-1} is mapped to $D_0 \setminus S$, D_{-2} to D_{-1} , etc.

and P is the contractive projection in $L^p(D, \lambda)$ onto the range of H , given as the averaging operator over the sets N_i :

$$Pf(u, v) := \begin{cases} \frac{1}{\lambda(N_i)} \int_{N_i} f \, d\lambda = \int_{N_i} f \, d\lambda, & \text{if } (u, v) \in N_i \text{ for some } i \in I; \\ 0 & \text{otherwise.} \end{cases} \tag{I.5}$$

The proof of (I.4) will be split into several lemmas.

Lemma I.1.7. *If $f, g \in L^p(D, \lambda)$ are two functions supported in $D_0 \cup \bigcup_{k \geq 1} D_k$ which depend only on the first coordinate, then $Pf = Pg$ implies $PUf = PUG$. Furthermore, PUf and PUG have their supports in $D_0 \cup \bigcup_{k \geq 1} D_k$ again.*

Proof. If $f : D \rightarrow \mathbb{R}$, $(u, v) \mapsto f(u, v)$, depends only on the u -coordinate we may define $F(u) := f(u, v)$ for $(u, v) \in D$. For $j \in J$ we then have

$$\begin{aligned} \int_{N_j} Uf \, d\lambda &= \sum_{i \in I} \int_{S_{ij}} \rho^{1/p} f(\tau_{ij}^{-1}) \, d\lambda = \sum_{i \in I} \int_{S_{ij}} \rho^{1/p} \rho^{-1} f(\tau_{ij}^{-1}) \, d\mu \\ &= \sum_{i \in I} \left(\frac{y_j}{x_i}\right)^{1-p} \int_{R_{ij}} f \, d\lambda = \sum_{i \in I} \left(\frac{y_j}{x_i}\right)^{1-p} \int_{R_{ij}} F(u) \, du \, dv \\ &= \sum_{i \in I} \left(\frac{y_j}{x_i}\right)^{1-p} \eta_{ij} \int_{I_i} F(u) \, du = \sum_{i \in I} t_{ji} \int_{N_i} f \, d\lambda, \end{aligned}$$

keeping in mind that $|N_i| = 1$ in the last step. If $j \in I \setminus J$ then $N_j \subseteq D_0 \setminus S$ and $\tau^{-1}(N_j) \subseteq D_{-1}$. It follows that $PUf = 0$ on N_j whenever $f = 0$ on D_{-1} . Hence,

$$PUf = \sum_{j \in J} \sum_{i \in I} t_{ji} \int_{N_i} f \, d\lambda \mathbf{1}_{N_j}. \tag{I.6}$$

Now, if $Pf = Pg$ and f, g are both supported in $D_0 \cup \bigcup_{k \geq 1} D_k$, then for all $j \in J$ we have $\int_{N_j} f \, d\lambda = \int_{N_j} g \, d\lambda$ and hence $PUf = PUG$ by (I.6). \square

Lemma I.1.8. *For all $\xi \in E$ and $k \in \mathbb{Z}_+$ we have*

$$PU^k \left(\sum_{i \in I} \xi_i \mathbf{1}_{N_i} \right) = \sum_{j \in J} (T^k \xi)_j \mathbf{1}_{N_j}.$$

Proof. We prove the lemma by induction on k . For $k = 0$ the assertion follows from $P\mathbf{1}_{N_i} = \mathbf{1}_{N_i}$ if $i \in J$ and $P\mathbf{1}_{N_i} = 0$ if $i \notin J$. The case $k = 1$ follows from (I.6) since

$$\begin{aligned} PU \left(\sum_{i \in I} \xi_i \mathbf{1}_{N_i} \right) &= \sum_{j \in J} \sum_{m \in I} t_{jm} \int_{N_m} \sum_{i \in I} \xi_i \mathbf{1}_{N_i} \, d\lambda \mathbf{1}_{N_j} \\ &= \sum_{j \in J} \sum_{m \in I} t_{jm} \xi_m \mathbf{1}_{N_j} = \sum_{j \in J} (T\xi)_j \mathbf{1}_{N_j}. \end{aligned}$$

For the induction step, suppose the lemma has been shown for the indices $0, 1, \dots, k$. Since $f = \sum_{i \in I} \xi_i \mathbf{1}_{N_i}$ depends only on the u -coordinate, the same is true for Uf , since τ is piecewise affine and the Radon–Nikodým derivative ρ depends only on the u -coordinate. Hence $U^k f$ depends only on the u -coordinate. Since, trivially,

$$P\left(U^k\left(\sum_{i \in I} \xi_i \mathbf{1}_{N_i}\right)\right) = P\left(PU^k \sum_{i \in I} \xi_i \mathbf{1}_{N_i}\right),$$

by Lemma I.1.7 we obtain

$$\begin{aligned} PU^{k+1}\left(\sum_{i \in I} \xi_i \mathbf{1}_{N_i}\right) &= PU\left(U^k\left(\sum_{i \in I} \xi_i \mathbf{1}_{N_i}\right)\right) \\ &= PU\left(PU^k \sum_{i \in I} \xi_i \mathbf{1}_{N_i}\right) \\ &= PU\left(\sum_{i \in I} (T^k \xi)_i \mathbf{1}_{N_i}\right) \\ &\stackrel{(1.6)}{=} \sum_{j \in J} \sum_{m \in I} t_{jm} \int_{N_m} \left(\sum_{i \in I} (T^k \xi)_i \mathbf{1}_{N_i}\right) d\lambda \mathbf{1}_{N_j} \\ &= \sum_{j \in J} \sum_{i \in I} t_{ji} (T^k \xi)_i \mathbf{1}_{N_j} = \sum_{j \in J} (T^{k+1} \xi)_j \mathbf{1}_{N_j}. \end{aligned}$$

This concludes the induction step. □

Combining the preceding lemmas we obtain $JT^n = PU^n J$ for all $n = 0, 1, \dots$. As we have already pointed out, this concludes the proof of Theorem I.1.2. □

Remark I.1.9. In some applications, notably the proof of Theorem I.2.1 below, it suffices to consider the special case where $t_{ij} > 0$ for all $1 \leq i, j \leq n$ and $\|T\| = 1$. Under these conditions we have $J = I = \{1, \dots, n\}$ in (I.2) and $\sum_{j \in J} \eta_{ij} = \sum_{j=1}^n \eta_{ij} = 1$ in (I.3), the reason for the latter being that we now have equality $M_T x = x^{p-1}$ in Lemma I.1.4. The action of τ becomes trivial on the sets D_k for $k \neq 0$ and they can be omitted from the construction; they were introduced only to accommodate the possibility that $\sum_{j \in J} \eta_{ij} < 1$.

I.2 Maximal ergodic averages

The main result of this section is the following maximal theorem which, besides its independent interest, also illustrates the application of Theorem I.1.2.

Theorem I.2.1 (Akçoglu). *Let (S, \mathcal{A}, μ) be a measure space, $1 < p < \infty$, and T be a positive contraction on $L^p(S)$. Then, for each $f \in L^p(S)$,*

$$\left\| \sup_{n \geq 1} \left| \frac{1}{n} \sum_{m=0}^{n-1} T^m f \right| \right\|_p \leq p' \|f\|_p.$$

We begin by establishing an important special case:

Lemma I.2.2 (Hardy and Littlewood). *Theorem I.2.1 holds for $S = \mathbb{Z}$ and the forward shift $Tf(x) := f(x + 1)$.*

Proof. In this case

$$\sup_{n \geq 1} |n^{-1} \sum_{m=0}^{n-1} T^m f(x)| =: Mf(x)$$

is a one-sided Hardy–Littlewood maximal function. Consider the set

$$\{x \in \mathbb{Z} : Mf(x) > \lambda\} \cap [-N, \infty).$$

If it is non-empty, let x_1 be its smallest element, and let $y_1 > x_1$ be the smallest integer such that

$$\frac{1}{y_1 - x_1} \sum_{k=x_1}^{y_1} |f(k)| > \lambda.$$

Assuming that $x_1 < y_1 \leq x_2 < y_2 \leq \dots \leq x_{m-1} < y_{m-1}$ are already chosen, let $x_m \geq y_{m-1}$ be the smallest integer such that $Mf(x_m) > \lambda$, and let $y_m > x_m$ be the smallest integer such that

$$\frac{1}{y_m - x_m} \sum_{k=x_m}^{y_m} |f(k)| > \lambda.$$

Continuing this way we find that every $x \geq -N$ such that $Mf(x) > \lambda$ is contained in some $I_m := [x_m, y_m) \cap \mathbb{Z}$ such that

$$\frac{1}{\#I_m} \sum_{k \in I_m} |f(k)| > \lambda,$$

and these intervals are disjoint. Hence

$$\#\{x \geq -N : Mf(x) > \lambda\} \leq \sum_{m=1}^{\infty} \#I_m \leq \frac{1}{\lambda} \sum_{m=1}^{\infty} \sum_{k \in I_m} |f(k)| \leq \frac{1}{\lambda} \|f\|_{\ell^1(\mathbb{Z})}.$$

Taking the limit $N \rightarrow \infty$ we see that

$$\|Mf\|_{\ell^1, \infty(\mathbb{Z})} \leq \|f\|_{\ell^1(\mathbb{Z})}.$$

Now the estimate in $\ell^p(\mathbb{Z})$ follows by the Marcinkiewicz interpolation theorem (Corollary 2.2.4) from the established weak ℓ^1 bound and a trivial ℓ^∞ bound, both of which have constant 1. \square

We proceed to a somewhat more general special case of the theorem:

Lemma I.2.3. *Theorem I.2.1 holds for positive invertible isometries.*

Proof. The proof consists of a reduction to the previous Lemma I.2.2.

For $0 \leq g \in L^p(S)$ and $N \geq 1$ define

$$M_N g := \max_{1 \leq n \leq N} \frac{1}{n} \sum_{m=0}^{n-1} T^m g, \quad M g := \sup_{n \geq 1} \frac{1}{n} \sum_{m=0}^{n-1} T^m g,$$

where the maximum and supremum are taken pointwise with respect to S .

In view of the inequality $|T^m f| \leq T^m |f|$, to prove the lemma it suffices to consider positive functions $f \geq 0$. We fix such a function and keep $N \geq 1$ fixed for the moment. For $k = 1, \dots, N$ and $j \in \mathbb{Z}$ let

$$A_{j,k} := \left\{ s \in S : M_N(T^j f) = \frac{1}{k} \sum_{m=0}^{k-1} T^{j+m} f \right\}$$

be the set of all $s \in S$ where the maximum in the definition of $M_N(T^j f)$ is taken at index $n = k$. On $A_{j,k}$ we have the pointwise inequality

$$M_N(T^j f) = T^j \left(\frac{1}{k} \sum_{m=0}^{k-1} T^m f \right) \leq T^j \left(\max_{1 \leq n \leq N} \frac{1}{n} \sum_{m=0}^{n-1} T^m f \right) = T^j(M_N f)$$

using the positivity of T in the middle step. Since $S = A_{j,1} \cup \dots \cup A_{j,N}$, it follows that $(M(T^j f))_N \leq T^j(M_N f)$ on S , and taking L^p -norms gives

$$\|M_N(T^j f)\|_p \leq \|T^j(M_N f)\|_p.$$

Applying this to $T^{-j} f$ in place of f and using that T is a contraction, we obtain

$$\|M_N f\|_p \leq \|T^j(M_N(T^{-j} f))\|_p \leq \|M_N(T^{-j} f)\|_p.$$

Averaging over $-k \leq j \leq k$, this implies

$$\begin{aligned} \|M_N f\|_p^p &\leq \frac{1}{2k+1} \sum_{j=-k}^k \int_S |M_N(T^j f)|^p d\mu \\ &= \frac{1}{2k+1} \int_S \sum_{j=-k}^k \left(\max_{1 \leq n \leq N} \frac{1}{n} \sum_{m=0}^{n-1} T^{j+m} f \right)^p d\mu \\ &\leq \frac{1}{2k+1} \int_S \sum_{j \in \mathbb{Z}} \left(\max_{1 \leq n \leq N} \frac{1}{n} \sum_{m=0}^{n-1} \mathbf{1}_{[-k, k+N-1]}(j+m) T^{j+m} f \right)^p d\mu. \end{aligned}$$

By Lemma I.2.2, applied to $\xi_j = \mathbf{1}_{[-k-N, k+N]}(j) T^j f(s)$ with $s \in S$,

$$\sum_{j \in \mathbb{Z}} \left(\max_{1 \leq n \leq N} \frac{1}{n} \sum_{m=0}^{n-1} \mathbf{1}_{[-k, k+N-1]}(j+m) T^{j+m} f(s) \right)^p$$

$$\leq (p')^p \sum_{j \in \mathbb{Z}} |\mathbf{1}_{[-k, k+N-1]}(j) T^j f(s)|^p = (p')^p \sum_{j=-k}^{k+N-1} |T^j f(s)|^p.$$

Putting things together and using that T is a contraction, this gives

$$\begin{aligned} \|M_N f\|_p^p &\leq (p')^p \frac{1}{2k+1} \sum_{j=-k}^{k+N-1} \int_S |T^j f|^p \, d\mu \\ &\leq (p')^p \frac{1}{2k+1} \sum_{j=-k}^{k+N-1} \|f\|_p^p = (p')^p \frac{2k+N}{2k+1} \|f\|_p^p. \end{aligned}$$

Letting $k \rightarrow \infty$ gives $\|M_N f\|_p \leq p' \|f\|_p$, and letting $N \rightarrow \infty$ we finally obtain $\|Mf\|_p \leq p' \|f\|_p$. \square

In order to deduce the general case from this lemma, we also need:

Lemma I.2.4. *For positive functions $f_1, g_1, \dots, f_k, g_k$ in $L^p(S)$, we have*

$$\left\| \max_{1 \leq j \leq k} f_j - \max_{1 \leq j \leq k} g_j \right\|_p \leq k^{1/p} \max_{1 \leq j \leq k} \|f_j - g_j\|_p.$$

Proof. Starting with the reverse triangle inequality $\|x\| - \|y\| \leq \|x - y\|$ in ℓ_k^∞ , we have

$$\begin{aligned} \left\| \max_{1 \leq j \leq k} f_j - \max_{1 \leq j \leq k} g_j \right\|_p &\leq \left\| \max_{1 \leq j \leq k} |f_j - g_j| \right\|_p \leq \left\| \left(\sum_{1 \leq j \leq k} |f_j - g_j|^p \right)^{1/p} \right\|_p \\ &= \left(\sum_{1 \leq j \leq k} \|f_j - g_j\|_p^p \right)^{1/p} \leq k^{1/p} \max_{1 \leq j \leq k} \|f_j - g_j\|_p. \end{aligned}$$

\square

Proof of Theorem I.2.1. It suffices to consider positive functions $f \geq 0$. The proof is divided into a number of steps.

Step 1 – First we will prove the theorem for positive contractions $T = (t_{ij})_{i,j=1}^n$ on ℓ_n^p . Let $\xi \geq 0$ be a positive element in ℓ_n^p and set

$$\bar{\xi}_j := \sup_{M \geq 1} \frac{1}{M} \sum_{m=0}^{M-1} (T^m \xi)_j, \quad j = 1, \dots, n.$$

Let U be a positive, invertible isometry of $L^p(D)$ dilating T , as provided by Theorem I.1.2, and let $f = \sum_{i=1}^n \xi_i \mathbf{1}_{N_i}$ be a simple function in $L^p(D)$, with the sets N_i as before. Set

$$\bar{f} := \sup_{M \geq 1} \frac{1}{M} \sum_{m=0}^{M-1} U^m f.$$

Then $\|f\|_p = \|\xi\|_p$ and, by Lemma I.2.3,

$$\|\bar{f}\|_p \leq p' \|f\|_p = p' \|\xi\|_p.$$

Denote by P the positive projection associated with the dilation of T , given by (I.5). Since P is positive we have

$$\sup_{M \geq 1} \frac{1}{M} \sum_{m=0}^{M-1} P U^m f \leq P \bar{f}.$$

But

$$\sup_{M \geq 1} \frac{1}{M} \sum_{m=0}^{M-1} P U^m f = \sup_{M \geq 1} \frac{1}{M} \sum_{m=0}^{M-1} \sum_{j \in J} (T^m \xi)_j \mathbf{1}_{N_j} = \sum_{j=1}^n \bar{\xi}_j \mathbf{1}_{N_j},$$

where the last equality uses the disjointness of the N_j . Therefore

$$\left\| \sup_{M \geq 1} \frac{1}{M} \sum_{m=0}^{M-1} T^m \xi \right\|_p = \|\bar{\xi}\|_p = \left\| \sum_{j=1}^n \bar{\xi}_j \mathbf{1}_{N_j} \right\|_p \leq \|P \bar{f}\|_p \leq p' \|\xi\|_p,$$

using that P is contractive in the last step.

Step 2 – The general case of a positive contraction on $L^p(S)$ will be handled by approximation. If $\pi := \{S_1, \dots, S_n\}$ is a finite partition of S , we define the positive contraction E_π on $L^p(S)$ by $E_\pi f = \sum_{i=1}^n c_i \mathbf{1}_{S_i}$, where

$$c_i = \begin{cases} \frac{1}{\mu(S_i)} \int_{S_i} f \, d\mu & \text{if } \mu(S_i) < \infty; \\ 0 & \text{otherwise.} \end{cases}$$

This operator is a close relative, but in general not strictly an instance, of the conditional expectations considered in Chapter 2, when $\mu(S_i) = \infty$ for some i . Below we shall use the following simple observation: Given an $\varepsilon > 0$ and any finite sequence f_1, \dots, f_k in $L^p(S)$, by a simple approximation argument it is possible to find a partition π of S such that $\|f_j - E_\pi f_j\|_p < \varepsilon$ for all $1 \leq j \leq k$.

We claim that if $\varepsilon > 0$, $f \in L^p(S)$, and an integer $k \geq 1$ are given, we can find a partition π of S such that

$$\|T^j f - (E_\pi T)^j E_\pi f\|_p < \varepsilon, \quad j = 0, 1, \dots, k-1. \tag{I.7}$$

Indeed, choose π so that $\|T^j f - E_\pi T^j f\|_p < \varepsilon/k$ for $j = 0, 1, \dots, k$. By induction on j we will show that

$$\|T^j f - (E_\pi T)^j E_\pi f\|_p < \varepsilon(j+1)/k \quad \text{for } j = 0, 1, \dots, k-1.$$

The result is true for $j = 0$. If it is true for j , then

$$\begin{aligned} & \|T^{j+1}f - (\mathbb{E}_\pi T)^{j+1}\mathbb{E}_\pi f\|_p \\ & \leq \|T^{j+1}f - \mathbb{E}_\pi T^{j+1}f\|_p + \|\mathbb{E}_\pi T\| \|T^j f - (\mathbb{E}_\pi T)^j \mathbb{E}_\pi f\|_p < \varepsilon/k + \varepsilon(j+1)/k \end{aligned}$$

by the choice of π , the contractivity of \mathbb{E}_π and T , and the induction hypothesis. This proves the claim (I.7) by induction.

Step 3 – To finish the proof, we observe by Step 1 that

$$\left\| \sup_{N \geq 1} \frac{1}{N} \sum_{m=0}^{N-1} (\mathbb{E}_\pi T)^m \mathbb{E}_\pi f \right\|_p \leq p' \|\mathbb{E}_\pi f\|_p \leq p' \|f\|_p,$$

since $\mathbb{E}_\pi f$ lives in the L^p -space over a measure space generated by the finitely many elements of $\pi = \{S_1, \dots, S_n\}$ of finite measure, which can be identified with $\ell_{n_1}^p$ for some $n_1 \leq n$, and $\mathbb{E}_\pi T$ is a positive contraction on this same space. On the other hand, by Lemma I.2.4, we have

$$\begin{aligned} & \left\| \max_{1 \leq N \leq k} \frac{1}{N} \sum_{m=0}^{N-1} T^m f - \max_{1 \leq N \leq k} \frac{1}{N} \sum_{m=0}^{N-1} (\mathbb{E}_\pi T)^m \mathbb{E}_\pi f \right\|_p \\ & \leq k^{1/p} \max_{1 \leq N \leq k} \left\| \frac{1}{N} \sum_{m=0}^{N-1} T^m f - \sum_{m=0}^{N-1} (\mathbb{E}_\pi T)^m \mathbb{E}_\pi f \right\|_p \\ & \leq k^{1/p} \max_{0 \leq m \leq k-1} \left\| T^m f - (\mathbb{E}_\pi T)^m \mathbb{E}_\pi f \right\|_p, \end{aligned}$$

where the right side can be made arbitrarily small by the choice of π , according to Step 3. Thus

$$\left\| \max_{1 \leq N \leq k} \frac{1}{N} \sum_{m=0}^{N-1} T^m f \right\|_p \leq p' \|f\|_p,$$

and passing to the limit $k \rightarrow \infty$, the theorem is proved. \square

I.3 Notes

Section I.1

The proof of Theorem I.1.2 follows the original argument of Akcoglu and Sucheston [1977] as presented in Fendler [1998]. The simpler case when T has norm one and strictly positive matrix elements, had been established before in Akcoglu [1975]; these additional assumptions could be avoided in Akcoglu and Sucheston [1977] thanks to Lemma I.1.3, which is from the same paper. In its most general form, the Akcoglu–Sucheston theorem can be formulated as follows.

Theorem I.3.1 (Akcoglu–Sucheston, Peller). *Let (S, \mathcal{A}, μ) be a measure space and let $1 < p < \infty$. For a bounded operator T on $L^p(S)$ the following assertions are equivalent:*

- (1) *there exists a measure space (T, \mathcal{B}, ν) such that T has a positive isometric dilation $L^p(T)$;*
- (2) *there exists a positive contraction \tilde{T} on $L^p(S)$ such that for all $f \in L^p(S)$ we have $|Tf| \leq \tilde{T}|f|$ μ -almost everywhere.*

The special case of the implication (2) \Rightarrow (1) for positive operators T is due to Akcoglu and Sucheston [1977] and is usually referred to as the Akcoglu–Sucheston theorem. Its extension to bounded operators dominated by a positive contraction, as well as the converse implication (1) \Rightarrow (2), is due to Peller [1983]. We refer to Peller [1983], Fendler [1998] for an extensive discussion of this theorem and its various ramifications and extension. The proofs in these references heavily rely on ultrapower techniques.

An alternative proof of the Akcoglu–Sucheston theorem based on Banach lattice arguments is due to Nagel and Palm [1982]; see also Kern, Nagel, and Palm [1977]. It also takes Lemma I.1.3 as its starting point, but the actual construction of the dilation is less elementary. Its main feature is that D is taken to be an infinite product rather than a union of infinitely many disjoint sets; the isometric extension is then obtained essentially by a shift on the indices.

A systematic ‘toolkit’ for producing isometric dilations is due to Fackler and Glück [2017]. Among other things, it includes general mechanisms to obtain simultaneous dilations and dilations of convex combinations.

Section I.2

Theorem I.2.1 is from Akcoglu [1975], whose proof we follow, except for a minor simplification: the original proof of Akcoglu [1975] was based on a special case of Theorem I.1.2 proved in the same paper, and required an additional step of reduction, which could be avoided with the full force of Theorem I.1.2 — this result of Akcoglu and Sucheston [1977] only became available slightly later. Lemma I.2.3, which establishes the special case of Theorem I.2.1 for positive invertible isometries, is due to Ionescu Tulcea [1964]; we present the simple proof due to De la Torre [1976].

Theorem I.2.1 is a substantial elaboration of the classical maximal ergodic theorem from Dunford and Schwartz [1958], based on earlier work of Hopf [1954], which achieves a similar conclusion as Theorem I.2.1 under the assumption that T is simultaneously contractive on $L^p(S)$ for all $p \in [1, \infty]$, whereas Theorem I.2.1 needs the assumption only for a fixed $p \in (1, \infty)$ in order to get the conclusion for this same p . We refer the reader to the notes of Dunford and Schwartz [1958] for the early history of such results. Stein [1970b, p. 48] refers to the Hopf–Dunford–Schwartz ergodic theorem as “one of the most powerful results in abstract analysis”.

An extension of Theorem I.2.1 to contractions acting on Bochner spaces of UMD lattice-valued functions is due to Xu [2015].

Muckenhoupt weights

A function $w \in L^1_{\text{loc}}(\mathbb{R}^d)$ is called a *weight* if $w(x) \in (0, \infty)$ almost everywhere. For $p \in (1, \infty)$ the Muckenhoupt A_p characteristic of a weight is defined by

$$[w]_{A_p} := \sup_Q \left(\int_Q w(x) \, dx \right) \left(\int_Q w^{1-p'}(x) \, dx \right)^{p-1}, \quad (\text{J.1})$$

where the supremum is over all (axes-parallel) cubes $Q \subseteq \mathbb{R}^d$. We say that w is an A_p weight if $[w]_{A_p} < \infty$.

J.1 Weighted boundedness of the maximal operator

We recall the Hardy–Littlewood maximal operator

$$Mf(x) := \sup_{Q \ni x} \int_Q |f(y)| \, dy,$$

where the supremum is over all axes-parallel cubes Q containing x . The dyadic maximal operator M_d is defined similarly by restricting the supremum to dyadic cubes only. For a weight w , we define the weighted maximal operator

$$M_w f(x) := \sup_{Q \ni x} \frac{1}{w(Q)} \int_Q |f(y)| w(y) \, dy, \quad w(Q) := \int_Q w(y) \, dy$$

and its dyadic version M_w^d by restricting to dyadic cubes only.

A key property of M_w^d is the ‘universal’ bound for $p \in (1, \infty)$

$$\|M_w^d f\|_{L^p(w)} \leq p' \|f\|_{L^p(w)}, \quad (\text{J.2})$$

where the constant is in particular independent of the particular weight w . This is simply a statement of Doob’s maximal inequality (Theorem 3.2.2) on the measure space $(\mathbb{R}^d, w(y) \, dy)$ equipped with the filtration generated by the dyadic cubes.

In (J.2), both the operator and the space is adapted to the weight w . Often we are concerned with a situation, where only the space but not the operator is modified, and it is in this case that the A_p weights make their appearance:

Theorem J.1.1 (Buckley, Muckenhoupt). *For each $p \in (1, \infty)$,*

$$\|Mf\|_{L^p(w)} \leq c_d p' [w]_{A_p}^{1/(p-1)} \|f\|_{L^p(w)}.$$

We prove this theorem via the following pointwise inequality:

Lemma J.1.2 (Lerner). *For $w \in A_p$ and $\sigma := w^{-1/(p-1)}$, we have*

$$(M_d f)^{p-1} \leq [w]_{A_p} M_w^d [(M_\sigma^d (f \sigma^{-1}))^{p-1} w^{-1}].$$

Proof.

$$\begin{aligned} \left(\frac{1}{|Q|} \int_Q f\right)^{p-1} &= \frac{w(Q)}{|Q|} \left(\frac{\sigma(Q)}{|Q|}\right)^{p-1} \frac{|Q|}{w(Q)} \left(\frac{1}{\sigma(Q)} \int_Q f \sigma^{-1} \sigma\right)^{p-1} \\ &\leq [w]_{A_p} \frac{|Q|}{w(Q)} \inf_Q [M_\sigma^d (f \sigma^{-1})]^{p-1} \\ &\leq [w]_{A_p} \frac{1}{w(Q)} \int_Q [M_\sigma^d (f \sigma^{-1})]^{p-1} w^{-1} w. \end{aligned}$$

Taking the supremum over all dyadic $Q \ni x$ gives the assertion. □

Proof of Theorem J.1.1. By Lemma J.1.2 and two applications of (J.2) (first with p' in place of p , and then with σ in place of w), we have

$$\begin{aligned} \|M_d f\|_{L^p(w)} &= \|(M_d f)^{p-1}\|_{L^{p'}(w)}^{1/(p-1)} \\ &\leq [w]_{A_p}^{1/(p-1)} \|M_w^d [(M_\sigma^d (f \sigma^{-1}))^{p-1} w^{-1}]\|_{L^{p'}(w)}^{1/(p-1)} \\ &\leq [w]_{A_p}^{1/(p-1)} (p \cdot \|(M_\sigma^d (f \sigma^{-1}))^{p-1} w^{-1}\|_{L^{p'}(w)})^{1/(p-1)} \\ &= [w]_{A_p}^{1/(p-1)} p^{1/(p-1)} \|M_\sigma^d (f \sigma^{-1})\|_{L^p(\sigma)} \\ &\leq [w]_{A_p}^{1/(p-1)} p^{1/(p-1)} \cdot p' \cdot \|f \sigma^{-1}\|_{L^p(\sigma)} \\ &= p^{1/(p-1)} \cdot p' \cdot [w]_{A_p}^{1/(p-1)} \|f\|_{L^p(w)} \end{aligned}$$

A standard calculus optimisation shows that $p^{1/(p-1)} \leq e$, so altogether

$$\|M_d f\|_{L^p(w)} \leq e \cdot p' \cdot [w]_{A_p}^{1/(p-1)} \|f\|_{L^p(w)}.$$

The case of the Hardy–Littlewood maximal operator follows from the pointwise domination of Mf by a sum of 3^d versions of the dyadic maximal operator (see (3.36)). □

J.2 Rubio de Francia's weighted extrapolation theorem

The following extrapolation result is one of the most useful tools in the theory of A_p weights:

Theorem J.2.1. *Let (f, h) be a pair of functions and $r \in (1, \infty)$. Suppose that*

$$\|h\|_{L^r(w)} \leq \phi_r([w]_{A_r}) \|f\|_{L^r(w)} \tag{J.3}$$

for all $w \in A_r$, where ϕ_r is a non-negative increasing function. Then

$$\|h\|_{L^p(w)} \leq \phi_{pr}([w]_{A_p}) \|f\|_{L^p(w)}$$

for all $p \in (1, \infty)$ and $w \in A_p$, where each ϕ_{pr} is a non-negative increasing function. In particular, if $\phi_r(t) = c_r t^\tau$, then $\phi_{pr}(t) \leq c_{pr} t^{\tau \max\{\frac{r-1}{p-1}, 1\}}$.

The proof naturally splits into two cases, $p \in (1, r)$ and $p \in (r, \infty)$. We first give the beginning of the proof, which motivates a certain auxiliary construction that is needed to complete it.

Proof of Theorem J.2.1, case $p \in (1, r)$, beginning

In order to use the assumed L^r inequality, we apply Hölder, after dividing and multiplying by an auxiliary function ψ , yet to be chosen:

$$\begin{aligned} \|h\|_{L^p(w)} &= \left(\int_{\mathbb{R}^d} \left(\frac{|h|}{\psi} \right)^p \cdot \psi^p w \right)^{1/p} \\ &\leq \left(\int_{\mathbb{R}^d} \left(\frac{|h|}{\psi} \right)^r \cdot \psi^p w \right)^{1/r} \left(\int_{\mathbb{R}^d} \psi^p w \right)^{1/p-1/r}. \end{aligned}$$

Now, we would like to apply (J.3) to the first factor, which would require that $\psi^{-r/p} w \in A_r$, and we would like to estimate the second factor by $\|f\|_{L^p(w)}$. We try to achieve this by some $\psi = Rf$. Thus, we would get

$$\begin{aligned} \|h\|_{L^p(w)} &\leq \left(\int_{\mathbb{R}^d} |h|^r (Rf)^{p-r} w \right)^{1/r} \left(\int_{\mathbb{R}^d} (Rf)^p w \right)^{1/p-1/r} \\ &\leq \phi_r([(Rf)^{p-r} w]_{A_r}) \left(\int_{\mathbb{R}^d} |h|^r (Rf)^{p-r} w \right)^{1/r} \\ &\quad \times \|R\|_{L^p(w) \rightarrow L^p(w)}^{1-p/r} \left(\int_{\mathbb{R}^d} |f|^p w \right)^{1/p-1/r} \\ &\leq \phi_r([(Rf)^{p-r} w]_{A_r}) \|R\|_{L^p(w) \rightarrow L^p(w)}^{1-p/r} \left(\int_{\mathbb{R}^d} |f|^p w \right)^{1/p}, \end{aligned} \tag{J.4}$$

provided that $Rf \geq |f|$, so that $(Rf)^{p-r} \leq |f|^{p-r}$ in the last step.

Altogether, we would like to have an operator R such that: $Rf \geq |f|$ pointwise, R is bounded on $L^p(w)$, and $(Rf)^{p-r} w \in A_r$ for all $w \in A_p$. Such an operator is constructed next:

The Rubio de Francia algorithm

The following general construction is the key to our problem. It has many other applications as well.

Proposition J.2.2 (Rubio de Francia algorithm). *For $\epsilon > 0$, consider the operator*

$$Rg = R_\epsilon g := \sum_{k=0}^{\infty} \epsilon^k M^k g,$$

where $M^0 g := |g|$, $M^1 g := Mg$ is the maximal function of g , and $M^k g := M(M^{k-1}g)$ is the k -fold iteration of M acting on g . Then this satisfies

- (i) $|g| \leq Rg$,
- (ii) $\|Rg\|_{L^p(w)} \leq \left(\sum_{k=0}^{\infty} \epsilon^k \|M\|_{L^p(w) \rightarrow L^p(w)}^k \right) \|g\|_{L^p(w)}$,
- (iii) $M(Rg) \leq \epsilon^{-1} Rg$.

In particular, if $\epsilon = \epsilon(p, w) := \frac{1}{2} \|M\|_{L^p(w) \rightarrow L^p(w)}^{-1}$, then

- (a) $\|Rg\|_{L^p(w)} \leq 2 \|g\|_{L^p(w)}$
- (b) $M(Rg) \leq 2 \|M\|_{L^p(w) \rightarrow L^p(w)} Rg \leq c_p [w]_{A_p}^{1/(p-1)} Rg$.

Here (i) says that Rg is bigger than g , but not too much bigger by (ii) or especially (a). The whole point of the construction is (iii) (or (b)), which shows that Rg is essentially invariant under the maximal operator.

Proof. (i) is clear, since Rg is a sum of non-negative terms, and the zeroth term is $|g|$. (ii) follows from the triangle inequality in $L^p(w)$ and iteration of the estimate

$$\|M^k g\|_{L^p(w)} \leq \|M\|_{L^p(w) \rightarrow L^p(w)} \|M^{k-1} g\|_{L^p(w)}.$$

Finally, by the sublinearity of M , we have

$$M(Rg) \leq \sum_{k=0}^{\infty} \epsilon^k M^{k+1} g = \epsilon^{-1} \sum_{k=0}^{\infty} \epsilon^{k+1} M^{k+1} g = \epsilon^{-1} \sum_{k=1}^{\infty} \epsilon^k M^k g \leq \epsilon^{-1} Rg,$$

which proves (iii). □

Remark J.2.3. In applications of the Rubio de Francia algorithm, the following consequence of (iii) is often handy: for $x \in Q$, we have

$$Rg(x) \geq \epsilon M(Rg)(x) \geq \epsilon \langle Rg \rangle_Q, \quad x \in Q. \tag{J.5}$$

Lemma J.2.4. *Let $1 < p < r < \infty$. Let $w \in A_p$, $f \in L^p(w)$ and let $\epsilon = \epsilon(p, w) := \frac{1}{2} \|M\|_{L^p(w) \rightarrow L^p(w)}^{-1}$. Then $W := (Rf)^{p-r} w = (R_\epsilon f)^{p-r} w$ satisfies $[W]_{A_r} \leq c_p^{r-p} [w]_{A_p}^{(r-1)/(p-1)}$.*

Substituting Lemma J.2.4 into (J.4), we obtain

$$\|h\|_{L^p(w)} \leq \phi_r(c_p^{r-p}[w]_{A_p}^{(r-1)/(p-1)}) \cdot 2^{1-p/r} \cdot \|f\|_{L^p(w)},$$

which completes the proof of Theorem J.2.1 in the case $p \in (1, r)$.

Proof of the Lemma. By (J.5), since $r - p > 0$, we have

$$\langle W \rangle_Q \leq \langle (Rf)^{p-r} w \rangle_Q \leq \epsilon^{p-r} \langle Rf \rangle_Q^{p-r} \langle w \rangle_Q,$$

whereas by Hölder's inequality, the second factor is

$$\begin{aligned} \langle W^{-1/(r-1)} \rangle_Q^{r-1} &= \langle (Rf)^{(r-p)/(r-1)} w^{-1/(r-1)} \rangle_Q^{r-1} \\ &\leq \langle Rf \rangle_Q^{r-p} \langle w^{-1/(p-1)} \rangle_Q^{p-1}. \end{aligned}$$

Forming the product, the factors involving $\langle Rf \rangle_Q$ cancel out to give

$$\begin{aligned} \langle W \rangle_Q \langle W^{-1/(r-1)} \rangle_Q^{r-1} &\leq \epsilon^{p-r} \langle w \rangle_Q \langle w^{-1/(p-1)} \rangle_Q^{p-1} \\ &\leq (c_p[w]_{A_p}^{1/p-1})^{r-p} [w]_{A_p} = c_p^{r-p} [w]_{A_p}^{(r-1)/(p-1)}. \end{aligned}$$

□

Proof of Theorem J.2.1, case $p \in (r, \infty)$

In the attempt to argue by Hölder's inequality as before, we face the problem that "Hölder increases the exponent", while we now would like to use information about the smaller exponent r to get bounds for $p > r$. We circumvent this problem by duality:

$$\|h\|_{L^p(w)} = \sup \left\{ \int_{\mathbb{R}^d} |h| \cdot g : \|g\|_{L^{p'}(\sigma)} \leq 1 \right\}, \quad \sigma = w^{-1/(p-1)}.$$

Here it is useful to observe that

$$[w]_{A_p}^{1/p} = [\sigma]_{A_{p'}}^{1/p'}. \tag{J.6}$$

We use the Rubio de Francia algorithm $R = R_\epsilon$ with $\epsilon = \epsilon(p', \sigma)$ defined by

$$\epsilon^{-1} := 2 \|M\|_{L^{p'}(\sigma) \rightarrow L^{p'}(\sigma)} \leq c_{p'} [\sigma]_{A_{p'}}^{1/(p'-1)} = c_{p'} [w]_{A_p}, \tag{J.7}$$

and estimate

$$\begin{aligned} \int_{\mathbb{R}^d} |h| \cdot g &\leq \int_{\mathbb{R}^d} |h| \cdot Rg = \int_{\mathbb{R}^d} |h| \cdot \frac{Rg}{w} \cdot w = \int_{\mathbb{R}^d} |h| \cdot \left(\frac{Rg}{w}\right)^{1-u} \cdot \left(\frac{Rg}{w}\right)^u \cdot w \\ &\leq \left(\int_{\mathbb{R}^d} |h|^r \left(\frac{Rg}{w}\right)^{(1-u)r} w \right)^{1/r} \left(\int_{\mathbb{R}^d} \left(\frac{Rg}{w}\right)^{ur'} w \right)^{1/r'}. \end{aligned}$$

We demand that $ur' = p'$, so that $u = p'/r'$ and

$$(1 - u)r = \left(1 - \frac{p'}{r'}\right)r = r - \frac{p}{p-1}(r-1) = \frac{r(p-1) - p(r-1)}{p-1} = \frac{p-r}{p-1}.$$

Thus

$$\begin{aligned} \int_{\mathbb{R}^d} |h| \cdot g &\leq \left(\int_{\mathbb{R}^d} |h|^r (Rg)^{\frac{p-r}{p-1}} w^{\frac{r-1}{p-1}} \right)^{1/r} \left(\int_{\mathbb{R}^d} (Rg)^{p'} w^{1-p'} \right)^{1/r'} \\ &\leq \phi_r([W]_{A_r}) \left(\int_{\mathbb{R}^d} |f|^r (Rg)^{\frac{p-r}{p-1}} w^{r/p} w^{\frac{r-p}{p(p-1)}} \right)^{1/r} (2\|g\|_{L^{p'}(\sigma)})^{p'/r'} \\ &\leq \phi_r([W]_{A_r}) \left(\int_{\mathbb{R}^d} |f|^p w \right)^{1/p} \left(\int_{\mathbb{R}^d} (Rg)^{\frac{p-r}{p-1} \cdot (p/r)'} w^{\frac{r-p}{p(p-1)} \cdot (p/r)'} \right)^{1/r-1/p} 2^{p'/r'} \\ &= \phi_r([W]_{A_r}) \left(\int_{\mathbb{R}^d} |f|^p w \right)^{1/p} \left(\int_{\mathbb{R}^d} (Rg)^{p'} w^{-\frac{1}{p-1}} \right)^{1/r-1/p} 2^{p'/r'} \\ &\leq \phi_r([W]_{A_r}) \left(\int_{\mathbb{R}^d} |f|^p w \right)^{1/p} 2^{p'(1/r-1/p)} 2^{p'/r'} = 2\phi_r([W]_{A_r}) \|f\|_{L^p(w)}, \end{aligned} \tag{J.8}$$

where $W := (Rg)^{\frac{p-r}{p-1}} w^{\frac{r-1}{p-1}}$. The proof of Theorem J.2.1 is then completed by the following Lemma:

Lemma J.2.5. *Let $1 < r < p < \infty$, let $w \in A_p$, $g \in L^{p'}(w^{1-p'})$ and $R = R_\epsilon$ with $\epsilon = \epsilon(p', w^{1-p'})$. Then $W := (Rg)^{\frac{p-r}{p-1}} w^{\frac{r-1}{p-1}} \in A_r$, and $[W]_{A_r} \leq c_{pr}[w]_{A_p}$.*

Proof. We estimate $\langle W \rangle_Q$ by Hölder's inequality:

$$\langle W \rangle_Q \leq \langle Rg \rangle_Q^{(p-r)/(p-1)} \langle w \rangle_Q^{(r-1)/(p-1)},$$

and $\langle W^{-1/(r-1)} \rangle_Q^{r-1}$ with the help of (J.5):

$$\begin{aligned} \langle W^{-1/(r-1)} \rangle_Q^{r-1} &= \langle (Rg)^{-\frac{p-r}{(p-1)(r-1)}} w^{-\frac{1}{p-1}} \rangle_Q^{r-1} \\ &\leq \epsilon^{-\frac{p-r}{p-1}} \langle Rg \rangle_Q^{-(p-r)/(p-1)} \langle w^{-1/(p-1)} \rangle_Q^{r-1}. \end{aligned}$$

Forming the product, observing that terms with $\langle Rg \rangle_Q$ cancel out, and estimating ϵ^{-1} by (J.7), we are left with

$$\begin{aligned} \langle W \rangle_Q \langle W^{-1/(r-1)} \rangle_Q^{r-1} &\leq [Rg]_{A_1}^{(p-r)/(p-1)} (\langle w \rangle_Q \langle w^{-1/(p-1)} \rangle_Q^{p-1})^{(r-1)/(p-1)} \\ &\leq (c_{p'}[w]_{A_p})^{(p-r)/(p-1)} [w]_{A_p}^{(r-1)/(p-1)} = c_{p'}^{(p-r)/(p-1)} [w]_{A_p}, \end{aligned}$$

which is what we wanted. □

It is useful to extract the following additional information provided by the above argument:

Corollary J.2.6. *Let $1 < p, r < \infty$. Suppose that $f \in L^p(w)$ for some $w \in A_p$. Then $f \in L^r(W)$ for some $W \in A_r$.*

Proof. The conclusion is clear if $p = r$.

Case $1 < p < r$: Let $W := (Rf)^{p-r}w$, where $R = R_\epsilon$ and $\epsilon = \epsilon(p, w)$ are as in Proposition J.2.2. Then $W \in A_r$ by Lemma J.2.4 and

$$\int_{\mathbb{R}^d} |f|^r W = \int_{\mathbb{R}^d} |f|^r (Rf)^{p-r} w \leq \int_{\mathbb{R}^d} (Rf)^p w \leq 2^p \int_{\mathbb{R}^d} |f|^p w$$

by the properties of R guaranteed by Proposition J.2.2; thus $f \in L^r(W)$.

Case $r < p < \infty$: Take any non-zero function $g \in L^{p'}(w^{1-p'})$, and let $W := (Rg)^{\frac{p-r}{p-1}} w^{\frac{r-1}{p-1}}$, where $R = R_\epsilon$ and $\epsilon = \epsilon(p', w^{1-p'})$. Then $W \in A_r$ by Lemma J.2.5 and $\|f\|_{L^r(W)} \leq 2^{p'(1/r-1/p)} \|f\|_{L^p(w)}$ by a computation contained in (J.8). \square

J.3 Notes

In its qualitative form, Theorem J.1.1 is a classical result of Muckenhoupt [1972]. The (sharp) quantitative bound of the operator norm in terms of $[w]_{A_p}$ is due to Buckley [1993]. We have presented the simple approach to this theorem found by Lerner [2008].

The Extrapolation Theorem J.2.1, first in a qualitative form, was found by Rubio de Francia [1984], and shortly after (so soon that it was published earlier) another proof was given by García-Cuerva [1983]. The quantitative form given here is from Dragičević, Grafakos, Pereyra, and Petermichl [2005].

References

- Abels, H. Bounded imaginary powers and H_∞ -calculus of the Stokes operator in two-dimensional exterior domains. *Math. Z.*, 251(3):589–605, 2005a. [477](#)
- Abels, H. Bounded imaginary powers and H_∞ -calculus of the Stokes operator in unbounded domains. In *Nonlinear elliptic and parabolic problems*, volume 64 of *Progr. Nonlinear Differential Equations Appl.*, pages 1–15. Birkhäuser, Basel, 2005b. [477](#)
- Abels, H. and Y. Terasawa. On Stokes operators with variable viscosity in bounded and unbounded domains. *Math. Ann.*, 344(2):381–429, 2009. [477](#)
- Acosta, A. de. Inequalities for B -valued random vectors with applications to the strong law of large numbers. *Ann. Probab.*, 9(1):157–161, 1981. [147](#)
- Akcoglu, M. A. A pointwise ergodic theorem in L_p -spaces. *Canad. J. Math.*, 27(5):1075–1082, 1975. [574](#), [575](#)
- Akcoglu, M. A. and L. Sucheston. Dilations of positive contractions on L_p spaces. *Canad. Math. Bull.*, 20(3):285–292, 1977. [574](#), [575](#)
- Albiac, F. and N. J. Kalton. *Topics in Banach space theory*, volume 233 of *Graduate Texts in Mathematics*. Springer, New York, 2006. [47](#), [146](#), [149](#), [150](#), [469](#)
- Albrecht, D., X. Duong, and A. McIntosh. Operator theory and harmonic analysis. In *Instructional workshop on analysis and geometry, Part III (Canberra, 1995)*, volume 34 of *Proc. Centre Math. Appl. Austral. Nat. Univ.*, pages 77–136. Austral. Nat. Univ., Canberra, 1996. [469](#), [473](#)
- Aliprantis, C. D. and O. Burkinshaw. *Positive operators*. Springer, Dordrecht, 2006. Reprint of the 1985 original. [517](#)
- Amann, H. *Linear and quasilinear parabolic problems. Vol. I: Abstract linear theory*, volume 89 of *Monographs in Mathematics*. Birkhäuser Boston Inc., Boston, MA, 1995. [546](#)
- Amann, H., M. Hieber, and G. Simonett. Bounded H_∞ -calculus for elliptic operators. *Differ. Integral Equ.*, 7(3-4):613–653, 1994. [476](#)
- Amenta, A. and P. Auscher. Elliptic boundary value problems with fractional regularity data: the first order approach. *arXiv:1607.03852*, 2016. CRM Monograph Series (to appear). [474](#)

- Amenta, A., E. Lorist, and M.C. Veraar. Rescaled extrapolation for vector-valued functions. *arXiv:1703.06044*, 2017a. 482
- Amenta, A., E. Lorist, and M.C. Veraar. Fourier multipliers in Banach function spaces with UMD concavifications. *arXiv:1705.07792*, 2017b. 245, 482
- Arendt, W. *Heat kernels*. 2005/06. Internet Seminar Lecture Notes. 348
- Arendt, W. and S. Bu. The operator-valued Marcinkiewicz multiplier theorem and maximal regularity. *Math. Z.*, 240(2):311–343, 2002. 249
- Arendt, W. and S. Bu. Sums of bisectorial operators and applications. *Integral Equations Operator Theory*, 52(3):299–321, 2005. 473
- Arendt, W. and M. M. Duelli. Maximal L^p -regularity for parabolic and elliptic equations on the line. *J. Evol. Equ.*, 6(4):773–790, 2006. 473
- Arendt, W. and M. Kreuter. Mapping theorems for sobolev spaces of vector-valued functions. *Studia Math.* (online first), 2016. 249
- Arendt, W. and A. Zamboni. Decomposing and twisting bisectorial operators. *Studia Math.*, 197(3):205–227, 2010. 473
- Arendt, W., C. J. K. Batty, M. Hieber, and F. Neubrander. *Vector-valued Laplace transforms and Cauchy problems*, volume 96 of *Monographs in Mathematics*. Birkhäuser/Springer Basel AG, Basel, second edition, 2011. 546
- Arhancet, C. On a conjecture of Pisier on the analyticity of semigroups. *Semigroup Forum*, 91(2):450–462, 2015. 153, 481
- Arhancet, C. and C. Le Merdy. Dilation of Ritt operators on L^p -spaces. *Israel J. Math.*, 201(1):373–414, 2014. 471
- Arhancet, F., S. Fackler, and C. Le Merdy. Isometric dilations and H^∞ calculus for bounded analytic semigroups and Ritt operators. *Trans. Amer. Math. Soc.*, 369(10):6899–6933, 2017. 471, 476
- Asmar, N. H., E. Berkson, and T. A. Gillespie. Representations of groups with ordered duals and generalized analyticity. *J. Funct. Anal.*, 90(1):206–235, 1990. 474
- Auscher, P. On necessary and sufficient conditions for L^p -estimates of Riesz transforms associated to elliptic operators on \mathbb{R}^n and related estimates. *Mem. Amer. Math. Soc.*, 186(871):xviii+75, 2007. 472
- Auscher, P. Change of angle in tent spaces. *C. R. Math. Acad. Sci. Paris*, 349(5-6):297–301, 2011. 243
- Auscher, P. and S. Stahlhut. Remarks on functional calculus for perturbed first order Dirac operators. In *Operator theory in harmonic and non-commutative analysis*, pages 31–43. Springer-Verlag, 2013. 474
- Auscher, P. and S. Stahlhut. Functional calculus for first order systems of Dirac type and boundary value problems. *Mém. Soc. Math. Fr. (N.S.)*, (144):vii+164, 2016. 474
- Auscher, P., A. McIntosh, and A. Nahmod. Holomorphic functional calculi of operators, quadratic estimates and interpolation. *Indiana Univ. Math. J.*, 46(2):375–403, 1997. 473

- Auscher, P., S. Hofmann, M. Lacey, A. McIntosh, and Ph. Tchamitchian. The solution of the Kato square root problem for second order elliptic operators on \mathbb{R}^n . *Ann. of Math. (2)*, 156(2):633–654, 2002. 474
- Auscher, P., A. McIntosh, and E. Russ. Hardy spaces of differential forms and Riesz transforms on Riemannian manifolds. *C. R. Math. Acad. Sci. Paris*, 344(2):103–108, 2007. 472
- Auscher, P., A. Axelsson, and S. Hofmann. Functional calculus of Dirac operators and complex perturbations of Neumann and Dirichlet problems. *J. Funct. Anal.*, 255(2):374–448, 2008. 474
- Auscher, P., S. Hofmann, and J.-M. Martell. Vertical versus conical square functions. *Trans. Amer. Math. Soc.*, 364(10):5469–5489, 2012a. 473
- Auscher, P., C. Kriegler, S. Monniaux, and Pierre Portal. Singular integral operators on tent spaces. *J. Evol. Equ.*, 12(4):741–765, 2012b. 472
- Auscher, P., S. Monniaux, and P. Portal. The maximal regularity operator on tent spaces. *Commun. Pure Appl. Anal.*, 11(6):2213–2219, 2012c. 472
- Auscher, P., S. Monniaux, and P. Portal. On existence and uniqueness for non-autonomous parabolic cauchy problems with rough coefficients. *arXiv:1511.05134*, 2015. 472
- Axelsson, A., S. Keith, and A. McIntosh. Quadratic estimates and functional calculi of perturbed Dirac operators. *Invent. Math.*, 163(3):455–497, 2006. 473, 474
- Badrikian, A. and S. Chevet. *Mesures cylindriques, espaces de Wiener et fonctions aléatoires gaussiennes*. Lecture Notes in Mathematics, Vol. 379. Springer-Verlag, Berlin, 1974. 355
- Baernstein, II, A. and R. C. Culverhouse. Majorization of sequences, sharp vector Khinchin inequalities, and bisubharmonic functions. *Studia Math.*, 152(3):231–248, 2002. 48
- Baillon, J.-B. and Ph. Clément. Examples of unbounded imaginary powers of operators. *J. Funct. Anal.*, 100(2):419–434, 1991. 469
- Bakan, A. and S. Kaijser. Hardy spaces for the strip. *J. Math. Anal. Appl.*, 333(1):347–364, 2007. 560
- Bakry, D., I. Gentil, and M. Ledoux. *Analysis and geometry of Markov diffusion operators*, volume 348 of *Grundlehren der Mathematischen Wissenschaften*. Springer-Verlag, Cham, 2014. 48
- Ball, J. M. Strongly continuous semigroups, weak solutions, and the variation of constants formula. *Proc. Amer. Math. Soc.*, 63(2):370–373, 1977. 546
- Bandara, L. and A. Rosén. Riesz continuity of the Atiyah-Singer Dirac operator under perturbations of local boundary conditions. *arXiv:1703.06548*, 2017. 474
- Bandara, L., A. McIntosh, and A. Rosén. Riesz continuity of the Atiyah-Singer Dirac operator under perturbations of the metric. *arXiv:1603.03647*, 2016. 474
- Bañuelos, R., A. Bielaszewski, and K. Bogdan. Fourier multipliers for non-symmetric Lévy processes. In *Marcinkiewicz centenary volume*, volume 95

- of *Banach Center Publ.*, pages 9–25. Polish Acad. Sci. Inst. Math., Warsaw, 2011. [248](#)
- Bateman, M. and C. Thiele. L^p estimates for the Hilbert transforms along a one-variable vector field. *Anal. PDE*, 6(7):1577–1600, 2013. [245](#), [246](#)
- Batty, C. Unbounded operators: functional calculus, generation, perturbations. *Extracta Math.*, 24(2):99–133, 2009. [468](#)
- Baxendale, P. Gaussian measures on function spaces. *Amer. J. Math.*, 98(4): 891–952, 1976. [347](#)
- Beck, A. A convexity condition in Banach spaces and the strong law of large numbers. *Proc. Amer. Math. Soc.*, 13:329–334, 1962. [147](#)
- Beckner, W. Inequalities in Fourier analysis. *Ann. of Math. (2)*, 102(1): 159–182, 1975. [48](#)
- Beckner, W. Geometric inequalities in Fourier analysis. In *Essays on Fourier analysis in honor of Elias M. Stein (Princeton, NJ, 1991)*, volume 42 of *Princeton Math. Ser.*, pages 36–68. Princeton Univ. Press, Princeton, NJ, 1995. [50](#)
- Bergh, J. and J. Löfström. *Interpolation spaces. An introduction*, volume 223 of *Grundlehren der Mathematischen Wissenschaften*. Springer-Verlag, Berlin, 1976. [478](#)
- Berkson, E. and T. A. Gillespie. Spectral decompositions and harmonic analysis on UMD spaces. *Studia Math.*, 112(1):13–49, 1994. [242](#)
- Berkson, E., T. A. Gillespie, and P. S. Muhly. Abstract spectral decompositions guaranteed by the Hilbert transform. *Proc. London Math. Soc. (3)*, 53(3):489–517, 1986. [474](#)
- Berkson, E., T. A. Gillespie, and P. S. Muhly. Generalized analyticity in UMD spaces. *Ark. Mat.*, 27(1):1–14, 1989. [474](#)
- Billingsley, P. *Convergence of probability measures*. Wiley Series in Probability and Statistics. John Wiley & Sons Inc., New York, second edition, 1999. [509](#)
- Bilyj, O., E. Schrohe, and J. Seiler. H^∞ -calculus for hypoelliptic pseudodifferential operators. *Proc. Amer. Math. Soc.*, pages 1645–1656, 2010. [478](#)
- Blackadar, B. *Operator algebras*, volume 122 of *Encyclopaedia of Mathematical Sciences*. Springer-Verlag, Berlin, 2006. [346](#)
- Blasco, O., J. Fourie, and I. Schoeman. On operator valued sequences of multipliers and R -boundedness. *J. Math. Anal. Appl.*, 328(1):7–23, 2007. [244](#)
- Blunck, S. Maximal regularity of discrete and continuous time evolution equations. *Studia Math.*, 146(2):157–176, 2001. [471](#)
- Blunck, S. and P. C. Kunstmann. Weighted norm estimates and maximal regularity. *Adv. Differential Equations*, 7(12):1513–1532, 2002. [245](#)
- Blunck, S. and P. C. Kunstmann. Calderón-Zygmund theory for non-integral operators and the H^∞ functional calculus. *Rev. Mat. Iberoam.*, 19(3):919–942, 2003. [477](#)
- Bogachev, V. I. *Gaussian measures*, volume 62 of *Mathematical Surveys and Monographs*. American Mathematical Society, Providence, RI, 1998. [348](#), [355](#)

- Bonami, A. Étude des coefficients de Fourier des fonctions de $L^p(G)$. *Ann. Inst. Fourier (Grenoble)*, 20(fasc. 2):335–402 (1971), 1970. 47
- Bonami, A. and J.-L. Clerc. Sommes de Cesàro et multiplicateurs des développements en harmoniques sphériques. *Trans. Amer. Math. Soc.*, 183: 223–263, 1973. 241
- Borell, C. On the integrability of Banach space valued Walsh polynomials. In *Séminaire de probabilités, XIII (Univ. Strasbourg, Strasbourg, 1977/78)*, volume 721 of *Lecture Notes in Math.*, pages 1–3. Springer, Berlin, 1979. 48
- Bourgain, J. Some remarks on Banach spaces in which martingale difference sequences are unconditional. *Ark. Mat.*, 21(2):163–168, 1983. 473
- Bourgain, J. Vector valued singular integrals and the H^1 -BMO duality. In *Israel seminar on geometrical aspects of functional analysis (1983/84)*, pages XVI, 23. Tel Aviv Univ., Tel Aviv, 1984. 242
- Bourgain, J. Vector-valued singular integrals and the H^1 -BMO duality. In *Probability theory and harmonic analysis (Cleveland, Ohio, 1983)*, volume 98 of *Monogr. Textbooks Pure Appl. Math.*, pages 1–19. Dekker, New York, 1986. 241, 242, 246
- Bourgain, J., V. Milman, and H. Wolfson. On type of metric spaces. *Trans. Amer. Math. Soc.*, 294(1):295–317, 1986. 152
- Boydzhiev, K. and R. deLaubenfels. Semigroups and resolvents of bounded variation, imaginary powers and H^∞ functional calculus. *Semigroup Forum*, 45(3):372–384, 1992. 469
- Brzeźniak, Z. and J. M. A. M. van Neerven. Space-time regularity for linear stochastic evolution equations driven by spatially homogeneous noise. *J. Math. Kyoto Univ.*, 43(2):261–303, 2003. 348
- Brzeźniak, Z. and S. Peszat. Space-time continuous solutions to SPDE's driven by a homogeneous Wiener process. *Studia Math.*, 137(3):261–299, 1999. 348
- Buckley, S. M. Estimates for operator norms on weighted spaces and reverse Jensen inequalities. *Trans. Amer. Math. Soc.*, 340(1):253–272, 1993. 583
- Carathéodory, C. *Theory of functions of a complex variable*. Chelsea Publishing Company, New York, 1954. 248
- Carbonaro, O. and A. Dragičević. Functional calculus for generators of symmetric contraction semigroups. *Duke Math. J.*, 166(5):937–974, 2017. 475, 484
- Carmona, R. and S. Chevet. Tensor Gaussian measures on $L^p(E)$. *J. Funct. Anal.*, 33(3):297–310, 1979. 348
- Casazza, P. G., O. Christensen, and N. J. Kalton. Frames of translates. *Collect. Math.*, 52(1):35–54, 2001. 350
- Ciesielski, Z. Modulus of smoothness of the Brownian paths in the L^p norm. In *Constructive theory of functions (Varna, Bulgaria, 1991)*, pages 71–75, 1991. 346
- Ciesielski, Z. Orlicz spaces, spline systems, and Brownian motion. *Constr. Approx.*, 9(2-3):191–208, 1993. 346
- Clément, Ph. and J. Prüss. Completely positive measures and Feller semigroups. *Math. Ann.*, 287(1):73–105, 1990. 475

- Clément, Ph. and J. Prüss. An operator-valued transference principle and maximal regularity on vector-valued L_p -spaces. In *Evolution equations and their applications in physical and life sciences (Bad Herrenalb, 1998)*, volume 215 of *Lecture Notes in Pure and Appl. Math.*, pages 67–87. Dekker, New York, 2001. [469](#), [475](#)
- Clément, Ph., B. de Pagter, F. A. Sukochev, and H. Witvliet. Schauder decompositions and multiplier theorems. *Studia Math.*, 138(2):135–163, 2000. [242](#)
- Cobos, F. and Th. Kühn. Entropy numbers of embeddings of Besov spaces in generalized Lipschitz spaces. *J. Approx. Theory*, 112(1):73–92, 2001. [358](#)
- Coifman, R. R. and G. Weiss. *Transference methods in analysis*, volume 31 of *Conference Series in Mathematics*. American Mathematical Society, Providence, R.I., 1976. [474](#), [475](#)
- Coifman, R. R., Y. Meyer, and E. M. Stein. Some new function spaces and their applications to harmonic analysis. *J. Funct. Anal.*, 62(2):304–335, 1985. [473](#)
- Coifman, R. R., J. L. Rubio de Francia, and S. Semmes. Multiplicateurs de Fourier de $L^p(\mathbf{R})$ et estimations quadratiques. *C. R. Acad. Sci. Paris Sér. I Math.*, 306(8):351–354, 1988. [482](#)
- Coriasco, S., E. Schrohe, and J. Seiler. Bounded H^∞ -calculus for differential operators on conic manifolds with boundary. *Comm. Partial Differential Equations*, 32(2):229–255, 2007. [478](#)
- Cowling, M., I. Doust, A. McIntosh, and A. Yagi. Banach space operators with a bounded H^∞ functional calculus. *J. Austral. Math. Soc. Ser. A*, 60(1):51–89, 1996. [468](#), [469](#), [470](#), [471](#)
- Cowling, M. G. Harmonic analysis on semigroups. *Ann. Math. (2)*, 117:267–283, 1983. [475](#)
- Cox, S. G. and J. M. A. M. van Neerven. Convergence rates of the splitting scheme for parabolic linear stochastic Cauchy problems. *SIAM J. Numer. Anal.*, 48(2):428–451, 2010. [346](#)
- Cruz-Uribe, D. V., J. M. Martell, and C. Pérez. *Weights, extrapolation and the theory of Rubio de Francia*, volume 215 of *Operator Theory: Advances and Applications*. Birkhäuser/Springer Basel AG, Basel, 2011. [245](#)
- Davies, E. B. *One-parameter semigroups*, volume 15 of *London Mathematical Society Monographs*. Academic Press Inc., London, 1980. [546](#)
- Davies, E. B., L. Gross, and B. Simon. Hypercontractivity: a bibliographic review. In *Ideas and methods in quantum and statistical physics (Oslo, 1988)*, pages 370–389. Cambridge Univ. Press, Cambridge, 1992. [48](#)
- De la Peña, V. H. and E. Giné. *Decoupling*. Probability and its Applications (New York). Springer-Verlag, New York, 1999. [47](#), [48](#), [49](#)
- Defant, A. and E. A. Sánchez Pérez. Domination of operators on function spaces. *Math. Proc. Cambridge Philos. Soc.*, 146(1):57–66, 2009. [148](#)
- Demeter, C. and P. Silva. Some new light on a few classical results. *Colloq. Math.*, 140(1):129–147, 2015. [246](#)

- Denk, R., M. Hieber, and J. Prüss. \mathcal{R} -boundedness, Fourier multipliers and problems of elliptic and parabolic type. *Mem. Amer. Math. Soc.*, 166(788), 2003. [242](#), [244](#), [246](#), [468](#), [476](#)
- Denk, R., G. Dore, M. Hieber, J. Prüss, and A. Venni. New thoughts on old results of R. T. Seeley. *Math. Ann.*, 328(4):545–583, 2004. [476](#)
- Denk, R., J. Saal, and J. Seiler. Bounded H^∞ -calculus for pseudo-differential Douglis–Nirenberg systems of mild regularity. *Math. Nachr.*, 282(3):386–407, 2009. [478](#)
- Diestel, J., H. Jarchow, and A. Tonge. *Absolutely summing operators*, volume 43 of *Cambridge Studies in Advanced Mathematics*. Cambridge University Press, Cambridge, 1995. [46](#), [146](#), [148](#), [160](#), [346](#), [352](#), [353](#), [355](#)
- Dodds, P. G. and F. A. Sukochev. RUC-decompositions in symmetric operator spaces. *Integral Equations and Operator Theory*, 29(3):269–287, 1997. [147](#)
- Dore, G. H^∞ functional calculus in real interpolation spaces. *Stud. Math.*, 137(2):161–167, 1999. [478](#)
- Dore, G. H^∞ functional calculus in real interpolation spaces. II. *Stud. Math.*, 145(1):75–83, 2001. [478](#)
- Dore, G. and A. Venni. H^∞ functional calculus for sectorial and bisectorial operators. *Studia Math.*, 166(3):221–241, 2005. [473](#)
- Dragičević, O., L. Grafakos, M. C. Pereyra, and S. Petermichl. Extrapolation and sharp norm estimates for classical operators on weighted Lebesgue spaces. *Publ. Mat.*, 49(1):73–91, 2005. [583](#)
- Dudley, R. M. The sizes of compact subsets of Hilbert space and continuity of Gaussian processes. *J. Funct. Anal.*, 1:290–330, 1967. [357](#)
- Duelli, M. M. and L. W. Weis. Spectral projections, Riesz transforms and H^∞ -calculus for bisectorial operators. In *Nonlinear elliptic and parabolic problems*, volume 64 of *Progr. Nonlinear Differential Equations Appl.*, pages 99–111. Birkhäuser, Basel, 2005. [473](#)
- Duembgen, L. Bounding standard gaussian tail probabilities. *arXiv:1012.2063*, 2010. [509](#)
- Dümbgen, L., S. A. van de Geer, M. C. Veraar, and J. A. Wellner. Nemirovski’s inequalities revisited. *Amer. Math. Monthly*, 117(2):138–160, 2010. [146](#)
- Dunford, N. and J. T. Schwartz. *Linear operators. I: General theory*. Pure and Applied Mathematics, Vol. 7. Interscience Publishers, Inc., New York; Interscience Publishers, Ltd., London, 1958. [575](#)
- Duong, X. T. and A. McIntosh. Singular integral operators with non-smooth kernels on irregular domains. *Rev. Mat. Iberoam.*, 15(2):233–265, 1999. [476](#), [477](#)
- Duong, X. T. and D. W. Robinson. Semigroup kernels, Poisson bounds, and holomorphic functional calculus. *J. Funct. Anal.*, 142(1):89–128, 1996. [476](#), [477](#)
- Duong, X. T. and G. Simonett. H_∞ -calculus for elliptic operators with non-smooth coefficients. *Differ. Integral Equ.*, 10(2):201–217, 1997. [476](#)

- Duong, X. T. and L. X. Yan. Bounded holomorphic functional calculus for non-divergence form differential operators. *Differ. Integral Equ.*, 15(6):709–730, 2002. [475](#), [476](#)
- Duren, P. L. *Theory of H^p spaces*. Pure and Applied Mathematics, Vol. 38. Academic Press, New York-London, 1970. [559](#)
- Edwards, R. E. and G. I. Gaudry. *Littlewood-Paley and multiplier theory*. Springer-Verlag, Berlin, 1977. *Ergebnisse der Mathematik und ihrer Grenzgebiete, Band 90*. [241](#), [242](#)
- Egert, M. *On Kato's conjecture and mixed boundary conditions*. PhD thesis, TU Darmstadt, 2015. [473](#)
- Enflo, P. On the nonexistence of uniform homeomorphisms between L_p -spaces. *Ark. Mat.*, 8:103–105, 1969. [152](#)
- Enflo, P. On infinite-dimensional topological groups. In *Séminaire sur la géométrie des espaces de Banach (1977–1978)*. École Polytech., Palaiseau, 1978. Exp. No. 10–11, 11. [152](#), [480](#)
- Engel, K.-J. and R. Nagel. *One-parameter semigroups for linear evolution equations*, volume 194 of *Graduate Texts in Mathematics*. Springer-Verlag, New York, 2000. [546](#)
- Escher, J. and J. Seiler. Bounded H^∞ -calculus for pseudodifferential operators and applications to the Dirichlet-Neumann operator. *Trans. Amer. Math. Soc.*, 360(8):3945–3973, 2008. [478](#)
- Eskenazis, A., P. Nayar, and T. Tkocz. Gaussian mixtures: entropy and geometric inequalities. *arXiv:1611.04921*, 2016. [49](#)
- Fabes, E. B. and N. M. Rivière. Singular intervals with mixed homogeneity. *Studia Math.*, 27:19–38, 1966. [247](#)
- Fack, T. Type and cotype inequalities for noncommutative L^p -spaces. *J. Operator Theory*, 17(2):255–279, 1987. [146](#)
- Fackler, S. Regularity properties of sectorial operators: counterexamples and open problems. In *Operator semigroups meet complex analysis, harmonic analysis and mathematical physics*, volume 250 of *Oper. Theory Adv. Appl.*, pages 171–197. Birkhäuser/Springer, Cham, 2015. [484](#)
- Fackler, S. and J. Glück. A toolkit for constructing dilations on Banach spaces. preprint, 2017. [575](#)
- Fan, K. Minimax theorems. *Proc. Nat. Acad. Sci. U. S. A.*, 39:42–47, 1953. [245](#)
- Farwig, R. and R. Myong-Hwan. The resolvent problem and H^∞ -calculus of the Stokes operator in unbounded cylinders with several exits to infinity. *J. Evol. Equ.*, 7(3):497–528, 2007. [477](#)
- Fefferman, C. The multiplier problem for the ball. *Ann. of Math. (2)*, 94:330–336, 1971. [241](#)
- Feller, W. On the generation of unbounded semigroups of bounded linear operators. *Ann. Math. (2)*, 58:166–174, 1953. [547](#)
- Fendler, G. On dilations and transference for continuous one-parameter semigroups of positive contractions on \mathcal{L}^p -spaces. *Ann. Univ. Sarav. Ser. Math.*, 9(1), 1998. [574](#), [575](#)

- Figiel, T. On equivalence of some bases to the Haar system in spaces of vector-valued functions. *Bull. Polish Acad. Sci. Math.*, 36(3-4):119–131 (1989), 1988. [243](#)
- Figiel, T. and N. Tomczak-Jaegermann. Projections onto Hilbertian subspaces of Banach spaces. *Israel J. Math.*, 33(2):155–171, 1979. [345](#)
- Franks, E. Modified Cauchy kernels and functional calculus for operators on Banach space. *J. Austral. Math. Soc. Ser. A*, 63(1):91–99, 1997. [469](#)
- Franks, E. and A. McIntosh. Discrete quadratic estimates and holomorphic functional calculi in Banach spaces. *Bull. Austral. Math. Soc.*, 58(2):271–290, 1998. [560](#)
- Frey, D., A. McIntosh, and P. Portal. Conical square function estimates and functional calculi for perturbed Hodge-Dirac operators in L^p . *arXiv:1407.4774*, 2014. [472](#), [474](#)
- Fröhlich, A. *Stokes- und Navier-Stokes-Gleichungen in gewichteten Funktionenräumen*. PhD thesis, TU Darmstadt, 2001. [477](#)
- Fröhlich, A. The Stokes operator in weighted L^q -spaces. II. Weighted resolvent estimates and maximal L^p -regularity. *Math. Ann.*, 339(2):287–316, 2007. [245](#)
- Fröhlich, A. M. and L. W. Weis. H^∞ calculus and dilations. *Bull. Soc. Math. France*, 134(4):487–508, 2006. [476](#)
- Fuhrman, M. Analyticity of transition semigroups and closability of bilinear forms in Hilbert spaces. *Studia Math.*, 115(1):53–71, 1995. [547](#)
- Gaans, O. van. On R -boundedness of unions of sets of operators. In *Partial differential equations and functional analysis*, volume 168 of *Oper. Theory Adv. Appl.*, pages 97–111. Birkhäuser, Basel, 2006. [242](#)
- Gallarati, C. and M. C. Veraar. Maximal regularity for non-autonomous equations with measurable dependence on time. *Potential Anal.*, 46(3):527–567, 2017a. [245](#)
- Gallarati, C. and M. C. Veraar. Evolution families and maximal regularity for systems of parabolic equations. *Adv. Differential Equations*, 22(3-4):169–190, 2017b. [245](#)
- Gallarati, C., E. Lorist, and M. C. Veraar. On the ℓ^s -boundedness of a family of integral operators. *Rev. Mat. Iberoam.*, 32(4):1277–1294, 2016. [245](#)
- García-Cuerva, J. An extrapolation theorem in the theory of A_p weights. *Proc. Amer. Math. Soc.*, 87(3):422–426, 1983. [583](#)
- García-Cuerva, J. and J. L. Rubio de Francia. *Weighted norm inequalities and related topics*, volume 116 of *North-Holland Mathematics Studies*. North-Holland Publishing Co., Amsterdam, 1985. [245](#), [250](#)
- García-Cuerva, J., J. L. Torrea, and K. S. Kazarian. On the Fourier type of Banach lattices. In *Interaction between functional analysis, harmonic analysis, and probability (Columbia, MO, 1994)*, volume 175 of *Lecture Notes in Pure and Appl. Math.*, pages 169–179. Dekker, New York, 1996. [161](#)
- García-Cuerva, J., G. Mauceri, S. Meda, P. Sjögren, and J. L. Torrea. Functional calculus for the Ornstein-Uhlenbeck operator. *J. Funct. Anal.*, 183(2):413–450, 2001. [475](#), [484](#)

- Gardner, L. T. An elementary proof of the Russo-Dye theorem. *Proc. Amer. Math. Soc.*, 90(1):171, 1984. [346](#)
- Garling, D. J. H. *Inequalities: a journey into linear analysis*. Cambridge University Press, Cambridge, 2007. [146](#)
- Garling, D. J. H. and S. J. Montgomery-Smith. Complemented subspaces of spaces obtained by interpolation. *J. London Math. Soc. (2)*, 44(3):503–513, 1991. [146](#)
- Garnett, J. B. *Bounded analytic functions*, volume 236 of *Graduate Texts in Mathematics*. Springer-Verlag, New York, first edition, 2007. [559](#)
- Geißert, M. and P. C. Kunstmann. Weak Neumann implies H^∞ for Stokes. *J. Math. Soc. Japan*, 67(1):183–193, 2015. [477](#)
- Gelfand, I. M. Generalized random processes. *Dokl. Akad. Nauk SSSR (N.S.)*, 100:853–856, 1955. [345](#), [347](#)
- Giga, Y. Domains of fractional powers of the Stokes operator in L_r spaces. *Arch. Ration. Mech. Anal.*, 89:251–265, 1985. [477](#)
- Giga, Y., M. Gries, M. Hieber, A. Hussein, and T. Kashiwabara. Bounded H^∞ -calculus for the hydrostatic Stokes operator on L^p -spaces and applications. *Proc. Amer. Math. Soc.*, 2017. doi.org/10.1090/proc/13676. [477](#)
- Girardi, M. and L. W. Weis. Operator-valued Fourier multiplier theorems on $L_p(X)$ and geometry of Banach spaces. *J. Funct. Anal.*, 204(2):320–354, 2003a. [243](#), [248](#)
- Girardi, M. and L. W. Weis. Criteria for R-boundedness of operator families. In *Evolution equations*, volume 234 of *Lecture Notes in Pure and Appl. Math.*, pages 203–221. Dekker, New York, 2003b. [247](#)
- Goldstein, J. A. *Semigroups of linear operators and applications*. Oxford Mathematical Monographs. Oxford University Press, New York, 1985. [546](#)
- Goldys, B. and J. M. A. M. van Neerven. Transition semigroups of Banach space-valued Ornstein-Uhlenbeck processes. *Acta Appl. Math.*, 76(3):283–330, 2003. [547](#)
- Grabowski, P. and F. M. Callier. Admissible observation operators. Semigroup criteria of admissibility. *Integral Equations Operator Theory*, 25(2):182–198, 1996. [470](#)
- Grafakos, L. *Classical Fourier analysis*, volume 249 of *Graduate Texts in Mathematics*. Springer, New York, second edition, 2008. [245](#), [517](#)
- Grafakos, L. *Modern Fourier analysis*, volume 250 of *Graduate Texts in Mathematics*. Springer, New York, second edition, 2009. [245](#)
- Gross, L. Measurable functions on Hilbert space. *Trans. Amer. Math. Soc.*, 105:372–390, 1962. [345](#), [347](#), [348](#)
- Gross, L. Abstract Wiener spaces. In *Proc. fifth Berkeley sympos. math. statist. and probability (Berkeley, Calif., 1965/66)*, Vol. II: Contributions to Probability Theory, Part 1, pages 31–42. Univ. California Press, Berkeley, Calif., 1967. [345](#), [347](#), [348](#)
- Gross, L. Logarithmic Sobolev inequalities. *Amer. J. Math.*, 97(4):1061–1083, 1975. [48](#)

- Grothendieck, A. Résumé de la théorie métrique des produits tensoriels topologiques. *Bol. Soc. Mat. São Paulo*, 8:1–79, 1953. [148](#)
- Guerre-Delabrière, S. Some remarks on complex powers of $(-\Delta)$ and UMD spaces. *Illinois J. Math.*, 35(3):401–407, 1991. [473](#)
- Haagerup, U. The best constants in the Khintchine inequality. *Studia Math.*, 70(3):231–283 (1982), 1981. [48](#)
- Haagerup, U. and G. Pisier. Factorization of analytic functions with values in noncommutative L_1 -spaces and applications. *Canad. J. Math.*, 41(5): 882–906, 1989. [157](#)
- Haak, B. H. *Kontrolltheorie in Banachräumen und quadratische Abschätzungen*. PhD thesis, Karlsruhe, 2004. [349](#)
- Haak, B. H. and M. H. A. Haase. Square function estimates and functional calculi. *arXiv:1311.0453*, 2013. [471](#)
- Haak, B. H. and P. C. Kunstmann. Admissibility of unbounded operators and wellposedness of linear systems in Banach spaces. *Integral Equations Oper. Theory*, 55(4):497–533, 2006. [349](#)
- Haak, B. H., J. M. A. M. van Neerven, and M. C. Veraar. A stochastic Datko-Pazy theorem. *J. Math. Anal. Appl.*, 329(2):1230–1239, 2007. [350](#)
- Haase, M. and J. Rozendaal. Functional calculus for semigroup generators via transference. *J. Funct. Anal.*, 265(12):3345–3368, 2013. [474](#)
- Haase, M. and J. Rozendaal. Functional calculus on real interpolation spaces for generators of C_0 -groups. *Math. Nachr.*, 289(2-3):275–289, 2016. [478](#)
- Haase, M. H. A. *The functional calculus for sectorial operators*, volume 169 of *Operator Theory: Advances and Applications*. Birkhäuser Verlag, Basel, 2006. [468](#), [474](#)
- Haase, M. H. A. Functional calculus for groups and applications to evolution equations. *J. Evol. Equ.*, 7(3):529–554, 2007. [474](#)
- Haase, M. H. A. A transference principle for general groups and functional calculus on UMD spaces. *Math. Ann.*, 345(2):245–265, 2009. [474](#)
- Haase, M. H. A. Transference principles for semigroups and a theorem of Peller. *J. Funct. Anal.*, 261(10):2959–2998, 2011. [474](#)
- Haller-Dintelmann, R., H. Heck, and M. Hieber. Muckenhoupt weights and maximal L^p -regularity. *Arch. Math. (Basel)*, 81(4):422–430, 2003. [245](#)
- Haller-Dintelmann, R., H. Heck, and M. Hieber. L^p - L^q estimates for parabolic systems in non-divergence form with VMO coefficients. *J. London Math. Soc. (2)*, 74(3):717–736, 2006. [245](#)
- Haller, R., H. Heck, and A. Noll. Mihlin’s theorem for operator-valued Fourier multipliers in n variables. *Math. Nachr.*, 244:110–130, 2002. [246](#)
- Harboure, E., J. L. Torrea, and B. E. Viviani. A vector-valued approach to tent spaces. *J. Analyse Math.*, 56:125–140, 1991. [473](#)
- Hebisch, W., G. Mauceri, and S. Meda. Holomorphy of spectral multipliers of the Ornstein-Uhlenbeck operator. *J. Funct. Anal.*, 210(1):101–124, 2004. [475](#), [484](#)
- Heck, H. and M. Hieber. Maximal L^p -regularity for elliptic operators with VMO-coefficients. *J. Evol. Equ.*, 3(2):332–359, 2003. [476](#)

- Hieber, M. and J. Prüss. Functional calculi for linear operators in vector-valued L^p -spaces via the transference principle. *Adv. Differential Equations*, 3(6):847–872, 1998. [469](#), [474](#), [475](#)
- Hille, E. *Functional analysis and semi-groups*. American Mathematical Society Colloquium Publications, vol. 31. American Mathematical Society, New York, 1948. [547](#)
- Hille, E. and R. S. Phillips. *Functional analysis and semi-groups*. American Mathematical Society Colloquium Publications, vol. 31. American Mathematical Society, Providence, R.I., 1957. rev. ed. [546](#)
- Hinrichs, A. On the type constants with respect to systems of characters of a compact abelian group. *Studia Math.*, 118(3):231–243, 1996. [146](#), [149](#), [154](#)
- Hinrichs, A. K -convex operators and Walsh type norms. *Math. Nachr.*, 208:121–140, 1999. [154](#)
- Hoffman, K. *Banach spaces of analytic functions*. Prentice-Hall Series in Modern Analysis. Prentice-Hall, Inc., Englewood Cliffs, N. J., 1962. [559](#), [560](#)
- Hoffmann-Jørgensen, J. Sums of independent Banach space valued random variables. *Studia Math.*, 52:159–186, 1974. [51](#)
- Hoffmann-Jørgensen, J. Probability in Banach space. In *École d'été de probabilités de Saint-Flour, VI-1976*, volume 598 of *Lecture Notes in Math.*, pages 1–186. Springer-Verlag, Berlin, 1977. [147](#)
- Hoffmann-Jørgensen, J. and G. Pisier. The law of large numbers and the central limit theorem in Banach spaces. *Ann. Probab.*, 4(4):587–599, 1976. [147](#), [348](#)
- Hoffmann, M., N. J. Kalton, and T. Kucherenko. R -bounded approximating sequences and applications to semigroups. *J. Math. Anal. Appl.*, 294(2):373–386, 2004. [243](#), [244](#), [248](#), [477](#)
- Hofmann, S. and S. Mayboroda. Hardy and BMO spaces associated to divergence form elliptic operators. *Math. Ann.*, 344(1):37–116, 2009. [472](#)
- Hopf, E. The general temporally discrete Markoff process. *J. Rational Mech. Anal.*, 3:13–45, 1954. [575](#)
- Hytönen, T. P. Anisotropic Fourier multipliers and singular integrals for vector-valued functions. *Ann. Mat. Pura Appl. (4)*, 186(3):455–468, 2007a. [247](#)
- Hytönen, T. P. Aspects of probabilistic Littlewood-Paley theory in Banach spaces. In *Banach spaces and their applications in analysis*, pages 343–355. Walter de Gruyter, Berlin, 2007b. [473](#)
- Hytönen, T. P. Vector-valued singular integrals, and the border between the one-parameter and the multi-parameter theories. In *CMA/AMSI research symposium asymptotic geometric analysis, harmonic analysis, and related topics*, volume 42 of *Proc. Centre Math. Appl. Austral. Nat. Univ.*, pages 11–41. Austral. Nat. Univ., Canberra, 2007c. [247](#), [248](#)
- Hytönen, T. P. and A. McIntosh. Stability in p of the H^∞ -calculus of first-order systems in L^p . In *The AMSI-ANU Workshop on spectral theory and*

- harmonic analysis*, volume 44 of *Proc. Centre Math. Appl. Austral. Nat. Univ.*, pages 167–181. Austral. Nat. Univ., Canberra, 2010. 474
- Hytönen, T. P. and D. Potapov. Vector-valued multiplier theorems of Coifman-Rubio de Francia-Semmes type. *Arch. Math. (Basel)*, 87(3):245–254, 2006. 482
- Hytönen, T. P. and M. C. Veraar. On Besov regularity of Brownian motions in infinite dimensions. *Probab. Math. Statist.*, 28(1):143–162, 2008. 347
- Hytönen, T. P. and M. C. Veraar. R -boundedness of smooth operator-valued functions. *Integral Equations Operator Theory*, 63(3):373–402, 2009. 148, 243, 248, 349
- Hytönen, T. P. and L. W. Weis. On the necessity of property (α) for some vector-valued multiplier theorems. *Arch. Math. (Basel)*, 90(1):44–52, 2008. 247, 473
- Hytönen, T. P., A. McIntosh, and P. Portal. Kato’s square root problem in Banach spaces. *J. Funct. Anal.*, 254(3):675–726, 2008a. 243, 474
- Hytönen, T. P., J. M. A. M. van Neerven, and P. Portal. Conical square function estimates in UMD Banach spaces and applications to H^∞ -functional calculi. *J. Anal. Math.*, 106:317–351, 2008b. 242, 473
- Hytönen, T. P., A. McIntosh, and P. Portal. Holomorphic functional calculus of Hodge-Dirac operators in L^p . *J. Evol. Equ.*, 11(1):71–105, 2011. 474
- Hytönen, T. P., S. Li, and A. Naor. Quantitative affine approximation for UMD targets. *Discrete Anal.*, 2016. Paper No. 6, 37. 150, 248, 484
- Ionescu Tulcea, A. Ergodic properties of isometries in L_p spaces, $1 < p < \infty$. *Bull. Am. Math. Soc.*, 70:366–371, 1964. 575
- Itô, K. and M. Nisio. On the convergence of sums of independent Banach space valued random variables. *Osaka J. Math.*, 5:35–48, 1968. 51
- Jacob, B. and H. Zwart. Exact observability of diagonal systems with a one-dimensional output operator. *Int. J. Appl. Math. Comput. Sci.*, 11(6):1277–1283, 2001. 350
- James, R. C. Nonreflexive spaces of type 2. *Israel J. Math.*, 30(1-2):1–13, 1978. 146
- Jameson, G. J. O. *Summing and nuclear norms in Banach space theory*, volume 8 of *London Mathematical Society Student Texts*. Cambridge University Press, Cambridge, 1987. 148
- Janson, S. On hypercontractivity for multipliers on orthogonal polynomials. *Ark. Mat.*, 21(1):97–110, 1983. 50
- Johnson, W. B. and G. Schechtman. Embedding l_p^m into l_1^n . *Acta Math.*, 149(1-2):71–85, 1982. 150
- Junge, M., C. Le Merdy, and Q. Xu. Calcul fonctionnel et fonctions carrées dans les espaces L^p non commutatifs. *C. R., Math., Acad. Sci. Paris*, 337(2):93–98, 2003. 476
- Kahane, J.-P. Sur les sommes vectorielles $\sum \pm u_n$. *C. R. Acad. Sci. Paris*, 259:2577–2580, 1964. 48

- Kahane, J.-P. *Some random series of functions*, volume 5 of *Cambridge Studies in Advanced Mathematics*. Cambridge University Press, Cambridge, second edition, 1985. [46](#), [47](#), [48](#)
- Kaip, M. and J. Saal. The permanence of \mathcal{R} -boundedness and property (α) under interpolation and applications to parabolic systems. *J. Math. Sci. Univ. Tokyo*, 19(3):359–407, 2012. [153](#), [157](#), [248](#), [469](#)
- Kaiser, C. and L. W. Weis. Wavelet transform for functions with values in UMD spaces. *Studia Math.*, 186(2):101–126, 2008. [349](#)
- Kallenberg, O. *Foundations of modern probability*. Probability and its Applications (New York). Springer-Verlag, New York, second edition, 2002. [509](#)
- Kallianpur, G. Abstract Wiener processes and their reproducing kernel Hilbert spaces. *Z. Wahrscheinlichkeitstheorie und Verw. Gebiete*, 17:113–123, 1971. [345](#), [347](#)
- Kalton, N. J. A remark on sectorial operators with an H^∞ -calculus. In *Trends in Banach spaces and operator theory (Memphis, TN, 2001)*, volume 321 of *Contemp. Math.*, pages 91–99. Amer. Math. Soc., Providence, RI, 2003. [470](#), [485](#)
- Kalton, N. J. Rademacher series and decoupling. *New York J. Math.*, 11: 563–595 (electronic), 2005. [148](#)
- Kalton, N. J. and T. Kucherenko. Rademacher bounded families of operators on L_1 . *Proc. Amer. Math. Soc.*, 136(1):263–272 (electronic), 2008. [243](#)
- Kalton, N. J. and T. Kucherenko. Operators with an absolute functional calculus. *Math. Ann.*, 346(2):259–306, 2010. [478](#)
- Kalton, N. J. and G. Lancien. A solution to the problem of L^p -maximal regularity. *Math. Z.*, 235(3):559–568, 2000. [546](#)
- Kalton, N. J. and S. J. Montgomery-Smith. Set-functions and factorization. *Arch. Math. (Basel)*, 61(2):183–200, 1993. [148](#)
- Kalton, N. J. and P. Portal. Remarks on ℓ_1 and ℓ_∞ -maximal regularity for power-bounded operators. *J. Aust. Math. Soc.*, 84(3):345–365, 2008. [471](#)
- Kalton, N. J. and L. W. Weis. The H^∞ -calculus and sums of closed operators. *Math. Ann.*, 321(2):319–345, 2001. [157](#), [242](#), [244](#), [248](#), [469](#), [470](#), [475](#), [477](#)
- Kalton, N. J. and L. W. Weis. The H^∞ -calculus and square function estimates. In *Nigel J. Kalton Selecta, Vol. 1*, pages 715–764. Springer-Verlag, 2016. [345](#), [346](#), [348](#), [349](#), [469](#), [470](#)
- Kalton, N. J. and L. W. Weis. Euclidean structures and their applications to spectral theory. In preparation, preprint. [250](#), [470](#), [471](#), [485](#)
- Kalton, N. J., P. Kunstmann, and L. W. Weis. Perturbation and interpolation theorems for the H^∞ -calculus with applications to differential operators. *Math. Ann.*, 336(4):747–801, 2006. [470](#), [476](#), [477](#)
- Kalton, N. J., J. M. A. M. van Neerven, M. C. Veraar, and L. W. Weis. Embedding vector-valued Besov spaces into spaces of γ -radonifying operators. *Math. Nachr.*, 281:238–252, 2008. [349](#), [350](#)
- Kato, T. *Perturbation theory for linear operators*. Classics in Mathematics. Springer-Verlag, Berlin, 1995. Reprint of the 1980 edition. [468](#)

- Katok, A. and B. Hasselblatt. *Introduction to the modern theory of dynamical systems*, volume 54 of *Encyclopedia of Mathematics and its Applications*. Cambridge University Press, Cambridge, 1995. With a supplementary chapter by Katok and Leonardo Mendoza. 473
- Kern, M., R. Nagel, and G. Palm. Dilations of positive operators: construction and ergodic theory. *Math. Z.*, 156(3):265–277, 1977. 575
- Khintchine, A. Über dyadische Brüche. *Math. Z.*, 18(1):109–116, 1923. 48
- Komatsu, H. Fractional powers of operators. *Pacific J. Math.*, 19:285–346, 1966. 468
- König, H. On the best constants in the Khintchine inequality for Steinhaus variables. *Israel J. Math.*, 203(1):23–57, 2014. 48
- König, H. and S. Kwapien. Best Khintchine type inequalities for sums of independent, rotationally invariant random vectors. *Positivity*, 5(2):115–152, 2001. 48
- König, H. and L. Tzafriri. Some estimates for type and cotype constants. *Math. Ann.*, 256(1):85–94, 1981. 146
- Kriegler, C. Analyticity angle for non-commutative diffusion semigroups. *J. Lond. Math. Soc. (2)*, 83(1):168–186, 2011. 484
- Kriegler, C. Hörmander functional calculus for Poisson estimates. *Integral Equations Operator Theory*, 80(3):379–413, 2014. 249
- Kriegler, C. and C. Le Merdy. Tensor extension properties of $C(K)$ -representations and applications to unconditionality. *J. Aust. Math. Soc.*, 88(2):205–230, 2010. 250
- Kriegler, C. and L. W. Weis. Contractivity of the H^∞ -calculus and Blaschke products. In *Operator algebras, operator theory and applications*, volume 195 of *Oper. Theory Adv. Appl.*, pages 231–244. Birkhäuser Verlag, Basel, 2010. 469
- Kriegler, C. and L. W. Weis. Spectral multiplier theorems and averaged R -boundedness. *Semigroup Forum*, 94(2):260–296, 2017. 249
- Krivine, J. L. Théorèmes de factorisation dans les espaces réticulés. In *Séminaire Maurey-Schwartz 1973–1974: Espaces L^p , applications radonifiantes et géométrie des espaces de Banach, Exp. Nos. 22 et 23*, page 22. Centre de Math., École Polytech., Paris, 1974. 242
- Kucherenko, T. and L. W. Weis. Real interpolation of domains of sectorial operators on L_p -spaces. *J. Math. Anal. Appl.*, 310(1):278–285, 2005. 477
- Kühn, Th. γ -Radonifying operators and entropy ideals. *Math. Nachr.*, 107:53–58, 1982. 357, 358
- Kühn, Th. and T. P. Schonbek. Entropy numbers of diagonal operators between vector-valued sequence spaces. *J. London Math. Soc. (2)*, 64(3):739–754, 2001. 358
- Kunstmann, P. C. H^∞ -calculus for the Stokes operator on unbounded domains. *Arch. Math. (Basel)*, 91(2):178–186, 2008. 477
- Kunstmann, P. C. and A. Ullmann. \mathcal{R}_s -sectorial operators and generalized Triebel-Lizorkin spaces. *J. Fourier Anal. Appl.*, 20(1):135–185, 2014. 244, 245, 478

- Kunstmann, P. C. and L. W. Weis. Maximal L_p -regularity for parabolic equations, Fourier multiplier theorems and H^∞ -functional calculus. In *Functional analytic methods for evolution equations*, volume 1855 of *Lecture Notes in Math.*, pages 65–311. Springer, Berlin, 2004. [242](#), [245](#), [246](#), [248](#), [468](#), [470](#), [475](#)
- Kunstmann, P. C. and L. W. Weis. New criteria for the H^∞ -calculus and the Stokes operator on bounded Lipschitz domains. *J. Evol. Equ.*, 17:387–409, 2017. [477](#)
- Kuo, H.-H. *Gaussian measures in Banach spaces*, volume 463. Springer-Verlag, Berlin, 1975. Lecture Notes in Mathematics. [348](#)
- Kwapień, S. Isomorphic characterizations of inner product spaces by orthogonal series with vector valued coefficients. *Studia Math.*, 44:583–595, 1972. [149](#)
- Kwapień, S. On Banach spaces containing c_0 . *Studia Math.*, 52:187–188, 1974. A supplement to the paper by J. Hoffmann-Jørgensen, Sums of independent Banach space valued random variables, (*Studia Math.* **52** (1974), 159–186). [51](#), [52](#)
- Kwapień, S. and A. Pełczyński. The main triangle projection in matrix spaces and its applications. *Studia Math.*, 34:43–68, 1970. [157](#)
- Kwapień, S. and J. Szulga. Hypercontraction methods in moment inequalities for series of independent random variables in normed spaces. *Ann. Probab.*, 19(1):369–379, 1991. [48](#)
- Kwapień, S. and B. Szymański. Some remarks on Gaussian measures in Banach spaces. *Probab. Math. Statist.*, 1(1):59–65, 1980. [356](#)
- Kwapień, S. and W. A. Woyczyński. *Random series and stochastic integrals: single and multiple, 2nd ed.* Probability and its Applications. Birkhäuser Boston Inc., Boston, MA, 2002. [46](#), [48](#), [51](#)
- Kwapień, S., M. C. Veraar, and L. W. Weis. R -boundedness versus γ -boundedness. *Ark. Mat.*, 54(1):125–145, 2016. [242](#), [248](#), [249](#)
- Lancien, F. and C. Le Merdy. On functional calculus properties of Ritt operators. *Proc. Roy. Soc. Edinburgh Sect. A*, 145(6):1239–1250, 2015. [471](#)
- Lancien, G. Counterexamples concerning sectorial operators. *Arch. Math. (Basel)*, 71(5):388–398, 1998. [247](#), [469](#)
- Latała, R. and K. Oleszkiewicz. On the best constant in the Khinchin-Kahane inequality. *Studia Math.*, 109(1):101–104, 1994. [49](#)
- Latała, R. and K. Oleszkiewicz. A note on sums of independent uniformly distributed random variables. *Colloq. Math.*, 68(2):197–206, 1995a. [48](#)
- Latała, R. and K. Oleszkiewicz. A note on the constants in the Khinchin-Kahane inequality. Unpublished manuscript, 1995b. [49](#)
- Latała, R. and K. Oleszkiewicz. Gaussian measures of dilatations of convex symmetric sets. *Ann. Probab.*, 27(4):1922–1938, 1999. [49](#)
- Le Merdy, C. On dilation theory for c_0 -semigroups on Hilbert space. *Indiana Univ. Math. J.*, 45(4):945–959, 1996. [470](#)
- Le Merdy, C. The similarity problem for bounded analytic semigroups on Hilbert space. *Semigroup Forum*, 56(2):205–224, 1998. [470](#)

- Le Merdy, C. The Weiss conjecture for bounded analytic semigroups. *J. London Math. Soc. (2)*, 67(3):715–738, 2003. [470](#)
- Le Merdy, C. On square functions associated to sectorial operators. *Bull. Soc. Math. France*, 132(1):137–156, 2004. [470](#)
- Le Merdy, C. Square functions, bounded analytic semigroups, and applications. In *Perspectives in operator theory*, volume 75 of *Banach Center Publ.*, pages 191–220. Polish Acad. Sci. Inst. Math., Warsaw, 2007. [470](#)
- Le Merdy, C. γ -Bounded representations of amenable groups. *Adv. Math.*, 224(4):1641–1671, 2010. [249](#)
- Le Merdy, C. A sharp equivalence between H^∞ functional calculus and square function estimates. *J. Evol. Equ.*, 12(4):789–800, 2012. [471](#)
- Le Merdy, C. H^∞ functional calculus and square function estimates for Ritt operators. *Rev. Mat. Iberoam.*, 30(4):1149–1190, 2014. [471](#), [472](#)
- Le Merdy, C. and A. Simard. A factorization property of R -bounded sets of operators on L^p -spaces. *Math. Nachr.*, 243:146–155, 2002. [250](#)
- Ledoux, M. and M. Talagrand. *Probability in Banach spaces: isoperimetry and processes*, volume 23 of *Ergebnisse der Mathematik und ihrer Grenzgebiete (3)*. Springer-Verlag, Berlin, 1991. [46](#), [48](#), [146](#), [147](#), [148](#), [347](#), [350](#)
- Lerner, A. K. An elementary approach to several results on the Hardy-Littlewood maximal operator. *Proc. Amer. Math. Soc.*, 136(8):2829–2833, 2008. [583](#)
- Li, D. and H. Queffélec. *Introduction à l'étude des espaces de Banach*, volume 12 of *Cours Spécialisés*. Société Mathématique de France, Paris, 2004. [146](#)
- Linde, V. and A. Pietsch. Mappings of Gaussian measures of cylindrical sets in Banach spaces. *Teor. Veroyatnost. i Primenen.*, 19:472–487, 1974. English translation in: *Theory Probab. Appl.* 19 (1974), 445–460. [345](#), [346](#), [353](#)
- Linde, W. *Probability in Banach spaces. Stable and infinitely divisible distributions*. A Wiley-Interscience Publication. John Wiley & Sons Ltd., Chichester, second edition, 1986. [147](#)
- Lindenstrauss, J. and A. Pełczyński. Contributions to the theory of the classical Banach spaces. *J. Funct. Anal.*, 8:225–249, 1971. [148](#), [149](#)
- Lindenstrauss, J. and L. Tzafriri. *Classical Banach spaces, Vol. II: Function spaces*, volume 97 of *Ergebnisse der Mathematik und ihrer Grenzgebiete*. Springer-Verlag, Berlin, 1979. [146](#), [149](#), [160](#), [242](#), [517](#)
- Lizorkin, P. I. (L_p, L_q) -multipliers of Fourier integrals. *Dokl. Akad. Nauk SSSR*, 152:808–811, 1963. [246](#)
- Lunardi, A. *Analytic semigroups and optimal regularity in parabolic problems*. Progress in Nonlinear Differential Equations and their Applications, 16. Birkhäuser Verlag, Basel, 1995. [546](#), [547](#)
- Lyubich, Yu. Spectral localization, power boundedness and invariant subspaces under Ritt's type condition. *Studia Math.*, 134(2):153–167, 1999. [472](#)

- Maas, J. and J. M. A. M. van Neerven. Boundedness of Riesz transforms for elliptic operators on abstract Wiener spaces. *J. Funct. Anal.*, 257(8): 2410–2475, 2009. [243](#), [474](#)
- Maier, S. and J. Saal. Stokes and Navier-Stokes equations with perfect slip on wedge type domains. *Discr. Contin. Dyn. Syst., Ser. S*, 7(5):1045–1063, 2014. [477](#)
- Marcinkiewicz, J. Sur les multiplicateurs des séries de Fourier. *Studia Math.*, 8:78–91, 1939. [246](#)
- Maurey, B. *Théorèmes de factorisation pour les opérateurs linéaires à valeurs dans les espaces L^p* . Société Mathématique de France, Paris, 1974a. With an English summary, Astérisque, No. 11. [250](#)
- Maurey, B. Type et cotype dans les espaces munis de structures locales inconditionnelles. In *Séminaire Maurey-Schwartz 1973–1974: Espaces L^p , applications radonifiantes et géométrie des espaces de Banach, Exp. Nos. 24 et 25*, page 25. Centre de Math., École Polytech., Paris, 1974b. [149](#)
- Maurey, B. Un théorème de prolongement. *C. R. Acad. Sci. Paris Sér. A*, 279:329–332, 1974c. [149](#)
- Maurey, B. Type, cotype and K -convexity. In *Handbook of the geometry of Banach spaces, Vol. 2*, pages 1299–1332. North-Holland, Amsterdam, 2003. [146](#), [150](#), [153](#)
- Maurey, B. and G. Pisier. Séries de variables aléatoires vectorielles indépendantes et propriétés géométriques des espaces de Banach. *Studia Math.*, 58(1):45–90, 1976. [148](#), [150](#), [153](#)
- McIntosh, A. Operators which have an H_∞ functional calculus. In *Miniconference on operator theory and partial differential equations (North Ryde, 1986)*, volume 14 of *Proc. Centre Math. Anal. Austral. Nat. Univ.*, pages 210–231. Austral. Nat. Univ., Canberra, 1986. [468](#), [469](#), [470](#), [471](#)
- McIntosh, A. and S. Monniaux. Hodge-Dirac, Hodge-Laplacian and Hodge-Stokes operators in L^p spaces on Lipschitz domains. *arXiv:1608.01797*, 2016. [474](#), [477](#)
- McIntosh, A. and A. Yagi. Operators of type ω without a bounded H_∞ functional calculus. In *Miniconference on operators in analysis (Sydney, 1989)*, volume 24 of *Proc. Centre Math. Anal. Austral. Nat. Univ.*, pages 159–172. Austral. Nat. Univ., Canberra, 1990. [468](#)
- Mendel, M. and A. Naor. Metric cotype. *Ann. of Math. (2)*, 168(1):247–298, 2008. [153](#)
- Meyer-Nieberg, P. *Banach lattices*. Universitext. Springer-Verlag, Berlin, 1991. [517](#)
- Mihlin, S. G. On the multipliers of Fourier integrals. *Dokl. Akad. Nauk SSSR (N.S.)*, 109:701–703, 1956. [246](#)
- Milman, V. D. and G. Schechtman. *Asymptotic theory of finite-dimensional normed spaces*, volume 1200 of *Lecture Notes in Mathematics*. Springer-Verlag, Berlin, 1986. With an appendix by M. Gromov. [150](#)
- Miyadera, I. On one-parameter semi-group of operators. *J. Math. Tokyo*, 1: 23–26, 1951. [546](#)

- Miyadera, I. Generation of a strongly continuous semi-group operations. *Tohoku Math. J. (2)*, 4:109–114, 1952. [547](#)
- Montgomery-Smith, S. J. The $p^{1/p}$ in Pisier’s factorization theorem. In *Geometry of Banach spaces (Strobl, 1989)*, volume 158 of *London Math. Soc. Lecture Note Ser.*, pages 231–235. Cambridge Univ. Press, Cambridge, 1990. [148](#)
- Mourier, É. Sur l’espérance mathématique d’un élément aléatoire dans un espace de Banach. *C. R. Acad. Sci. Paris*, 229:1300–1301, 1949. [147](#)
- Muckenhoupt, B. Weighted norm inequalities for the Hardy maximal function. *Trans. Amer. Math. Soc.*, 165:207–226, 1972. [583](#)
- Muckenhoupt, B. and E. M. Stein. Classical expansions and their relation to conjugate harmonic functions. *Trans. Amer. Math. Soc.*, 118:17–92, 1965. [241](#)
- Mushtari, D. H. *Probabilities and topologies on linear spaces*, volume 1 of *Kazan Tracts in Mathematics*. Kazan Mathematics Foundation, Kazan’, 1996. [355](#)
- Nagel, R. and G. Palm. Lattice dilations of positive contractions on L^p -spaces. *Canad. Math. Bull.*, 25(3):371–374, 1982. [575](#)
- Nagy, B. and J. Zemánek. A resolvent condition implying power boundedness. *Studia Math.*, 134(2):143–151, 1999. [472](#)
- Naor, A. An introduction to the Ribe program. *Jpn. J. Math.*, 7(2):167–233, 2012. [153](#)
- Naor, A. and G. Schechtman. Remarks on non linear type and Pisier’s inequality. *J. Reine Angew. Math.*, 552:213–236, 2002. [152](#), [480](#)
- Nau, T. and J. Saal. H^∞ -calculus for cylindrical boundary value problems. *Adv. Differential Equations*, 17(7-8):767–800, 2012. [476](#)
- Nayar, P. and K. Oleszkiewicz. Khinchine type inequalities with optimal constants via ultra log-concavity. *Positivity*, 16(2):359–371, 2012. [48](#)
- Neerven, J. M. A. M. van. Reflexivity, the dual Radon-Nikodým property, and continuity of adjoint semigroups. *Indag. Math. (N.S.)*, 1(3):365–379, 1990. [546](#)
- Neerven, J. M. A. M. van. *The adjoint of a semigroup of linear operators*, volume 1529 of *Lecture Notes in Mathematics*. Springer-Verlag, Berlin, 1992. [546](#)
- Neerven, J. M. A. M. van. γ -Radonifying operators—a survey. In *The AMSI-ANU Workshop on spectral theory and harmonic analysis*, volume 44 of *Proc. Centre Math. Appl. Austral. Nat. Univ.*, pages 1–61. Austral. Nat. Univ., Canberra, 2010. [346](#), [349](#)
- Neerven, J. M. A. M. van and L. W. Weis. Stochastic integration of functions with values in a Banach space. *Studia Math.*, 166(2):131–170, 2005a. [348](#), [349](#)
- Neerven, J. M. A. M. van and L. W. Weis. Weak limits and integrals of Gaussian covariances in Banach spaces. *Probab. Math. Statist.*, 25(1):55–74, 2005b. [348](#)

- Neerven, J. M. A. M. van and L. W. Weis. Invariant measures for the linear stochastic Cauchy problem and R -boundedness of the resolvent. *J. Evol. Equ.*, 6(2):205–228, 2006. [350](#)
- Neerven, J. M. A. M. van and L. W. Weis. Stochastic integration of operator-valued functions with respect to Banach space-valued Brownian motion. *Potential Anal.*, 29:65–88, 2008. [157](#), [158](#), [159](#), [349](#)
- Neerven, J. M. A. M. van, M. C. Veraar, and L. W. Weis. Stochastic integration in UMD Banach spaces. *Annals Probab.*, 35:1438–1478, 2007a. [346](#), [348](#)
- Neerven, J. M. A. M. van, M. C. Veraar, and L. W. Weis. Conditions for stochastic integrability in UMD Banach spaces. In *Banach spaces and their applications in analysis*, pages 125–146. Walter de Gruyter, Berlin, 2007b. [348](#), [350](#)
- Neerven, J. M. A. M. van, M. C. Veraar, and L. W. Weis. Stochastic evolution equations in UMD Banach spaces. *J. Funct. Anal.*, 255(4):940–993, 2008. [348](#)
- Neerven, J. M. A. M. van, M. C. Veraar, and L. W. Weis. On the R -boundedness of stochastic convolution operators. *Positivity*, 19(2):355–384, 2015. [160](#)
- Neidhardt, A. L. *Stochastic integrals in 2-uniformly smooth Banach spaces*. PhD thesis, University of Wisconsin, 1978. [345](#), [349](#)
- Nelson, E. A quartic interaction in two dimensions. In *Mathematical theory of elementary particles (Proc. Conf., Dedham, Mass., 1965)*, pages 69–73. M.I.T. Press, Cambridge, Mass., 1966. [47](#)
- Nelson, E. The free Markoff field. *J. Functional Analysis*, 12:211–227, 1973. [47](#)
- Noll, A. and J. Saal. H^∞ -calculus for the stokes operator on L_q -spaces. *Math. Z.*, 244(3):651–688, 2003. [477](#)
- Oleszkiewicz, K. On a nonsymmetric version of the Khinchine-Kahane inequality. In *Stochastic inequalities and applications*, volume 56 of *Progr. Probab.*, pages 157–168. Birkhäuser, Basel, 2003. [48](#)
- Oleszkiewicz, K. Precise moment and tail bounds for Rademacher sums in terms of weak parameters. *Israel J. Math.*, 203(1):429–443, 2014. [48](#), [49](#)
- Pagter, B. de and W. J. Ricker. $C(K)$ -representations and R -boundedness. *J. Lond. Math. Soc. (2)*, 76(2):498–512, 2007. [250](#)
- Pagter, B. de and W.J. Ricker. A note on R -boundedness in bidual spaces. In *Vector measures, integration and related topics*, volume 201 of *Oper. Theory Adv. Appl.*, pages 323–325. Birkhäuser Verlag, Basel, 2010. [248](#)
- Parthasarathy, K. R. *Probability measures on metric spaces*. Academic Press, New York-London, 1967. [509](#)
- Pazy, A. *Semigroups of linear operators and applications to partial differential equations*, volume 44 of *Applied Mathematical Sciences*. Springer-Verlag, New York, 1983. [546](#)
- Pelczyński, A. and I. Singer. On non-equivalent bases and conditional bases in Banach spaces. *Studia Math.*, 25:5–25, 1964/1965. [469](#)

- Peller, V. V. Estimates of functions of power bounded operators on Hilbert spaces. *J. Operator Theory*, 7(2):341–372, 1982. 474
- Peller, V. V. Analogue of J. von Neumann’s inequality, isometric dilation of contractions and approximation by isometries in spaces of measurable functions. In *Spectral theory of functions and operators. II*, pages 101–145. American Mathematical Society, Providence, R.I., 1983. A translation of Trudy Mat. Inst. Steklov. 155 (1981). 575
- Phillips, R. S. On one-parameter semi-groups of linear transformations. *Proc. Amer. Math. Soc.*, 2:234–237, 1951. 546
- Phillips, R. S. Perturbation theory for semi-groups of linear operators. *Trans. Amer. Math. Soc.*, 2:199–221, 1953. 547
- Phillips, R. S. The adjoint semi-group. *Pac. J. Math.*, 5:269–283, 1955. 546
- Pietsch, A. Absolut p -summierende Abbildungen in normierten Räumen. *Studia Math.*, 28:333–353, 1966/1967. 148
- Pietsch, A. *Operator ideals*, volume 20 of *North-Holland Mathematical Library*. North-Holland Publishing Co., Amsterdam, 1980. 357
- Pietsch, A. and J. Wenzel. *Orthonormal systems and Banach space geometry*, volume 70 of *Encyclopedia of Mathematics and its Applications*. Cambridge University Press, Cambridge, 1998. 47, 146, 154
- Pisier, G. Sur les espaces qui ne contiennent pas de l_n^1 uniformément. In *Séminaire Maurey-Schwartz (1973–1974), Espaces L^p , applications radonifiantes et géométrie des espaces de Banach, Exp. No. 7*, pages 19 pp. (errata, p. E.1). Centre de Math., École Polytech., Paris, 1974. 149
- Pisier, G. Les inégalités de Khintchine-Kahane, d’après C. Borell. In *Séminaire sur la Géométrie des Espaces de Banach (1977–1978)*, pages Exp. No. 7, 14. École Polytech., Palaiseau, 1978a. 52
- Pisier, G. Some results on Banach spaces without local unconditional structure. *Compositio Math.*, 37(1):3–19, 1978b. 157
- Pisier, G. Holomorphic semigroups and the geometry of Banach spaces. *Ann. of Math. (2)*, 115(2):375–392, 1982. 153, 480, 481
- Pisier, G. On the dimension of the l_p^n -subspaces of Banach spaces, for $1 \leq p < 2$. *Trans. Amer. Math. Soc.*, 276(1):201–211, 1983. 150
- Pisier, G. Probabilistic methods in the geometry of Banach spaces. In *Probability and analysis (Varenna, 1985)*, volume 1206 of *Lecture Notes in Math.*, pages 167–241. Springer, Berlin, 1986a. 148, 150, 152, 350, 480
- Pisier, G. *Factorization of linear operators and geometry of Banach spaces*, volume 60 of *CBMS Regional Conference Series in Mathematics*. Washington, DC, 1986b. 148
- Pisier, G. *The volume of convex bodies and Banach space geometry*, volume 94 of *Cambridge Tracts in Mathematics*. Cambridge University Press, Cambridge, 1989. 51, 146, 346
- Pisier, G. *Similarity problems and completely bounded maps*, volume 1618 of *Lecture Notes in Mathematics*. Springer-Verlag, Berlin, expanded edition, 2001. Includes the solution to “The Halmos problem”. 249

- Pisier, G. *Martingales in Banach spaces*, volume 155 of *Cambridge Studies in Advanced Mathematics*. Cambridge University Press, 2016. 146
- Portal, P. Discrete time analytic semigroups and the geometry of Banach spaces. *Semigroup Forum*, 67(1):125–144, 2003. 471
- Prüss, J. and G. Simonett. *Moving interfaces and quasilinear parabolic evolution equations*, volume 105 of *Monographs in Mathematics*. Birkhäuser, Basel, 2016. 477, 546
- Revuz, D. and M. Yor. *Continuous martingales and Brownian motion*, volume 293 of *Grundlehren der Mathematischen Wissenschaften*. Springer-Verlag, Berlin, third edition, 1999. 346
- Ribe, M. On uniformly homeomorphic normed spaces. *Ark. Mat.*, 14(2):237–244, 1976. 153
- Riesz, M. Sur les fonctions conjuguées. *Math. Z.*, 27(1):218–244, 1928. 241
- Rosiński, J. and Z. Suchanecki. On the space of vector-valued functions integrable with respect to the white noise. *Colloq. Math.*, 43(1):183–201 (1981), 1980. 348
- Roynette, B. Mouvement brownien et espaces de Besov. *Stochastics Stochastics Rep.*, 43(3-4):221–260, 1993. 347
- Rubio de Francia, J. L. Weighted norm inequalities and vector valued inequalities. In *Harmonic analysis (Minneapolis, Minn., 1981)*, volume 908 of *Lecture Notes in Math.*, pages 86–101. Springer, Berlin, 1982. 245
- Rubio de Francia, J. L. Factorization theory and A_p weights. *Amer. J. Math.*, 106(3):533–547, 1984. 245, 583
- Rubio de Francia, J. L. Martingale and integral transforms of Banach space valued functions. In *Probability and Banach spaces (Zaragoza, 1985)*, volume 1221 of *Lecture Notes in Math.*, pages 195–222. Springer, Berlin, 1986. 484
- Rudin, W. *Real and complex analysis*. McGraw-Hill, Inc., New York, third edition, 1987. 51, 560
- Schaefer, H. H. *Banach lattices and positive operators*, volume 215 of *Grundlehren der Mathematischen Wissenschaften*. Springer-Verlag, New York, 1974. 517
- Schur, J. Bemerkungen zur Theorie der beschränkten Bilinearformen mit unendlich vielen Veränderlichen. *J. Reine Angew. Math.*, 140:1–28, 1911. 157
- Schwartz, L. *Radon measures on arbitrary topological spaces and cylindrical measures*, volume 6 of *Tata Institute of Fundamental Research Studies in Mathematics*. Oxford University Press, London, 1973. 355
- Schwenninger, F. L. On measuring unboundedness of the H^∞ -calculus for generators of analytic semigroups. *J. Funct. Anal.*, 271(1):49–84, 2016a. 474
- Schwenninger, F. L. Functional calculus estimates for Tadmor-Ritt operators. *J. Math. Anal. Appl.*, 439(1):103–124, 2016b. 472
- Schwenninger, F. L. and H. Zwart. Weakly admissible \mathcal{H}_∞^- -calculus on reflexive Banach spaces. *Indag. Math. (N.S.)*, 23(4):796–815, 2012. 475

- Segal, I. E. Tensor algebras over Hilbert spaces. I. *Trans. Amer. Math. Soc.*, 81:106–134, 1956. [345](#), [347](#)
- Simon, B. *Harmonic analysis*. A comprehensive course in Analysis, Part 3. American Mathematical Society, Providence, RI, 2015. [48](#)
- Stečín, S. B. On the best lacunary system of functions. *Izv. Akad. Nauk SSSR Ser. Mat.*, 25:357–366, 1961. [48](#)
- Stein, E. M. Interpolation of linear operators. *Trans. Amer. Math. Soc.*, 83:482–492, 1956. [476](#)
- Stein, E. M. *Singular integrals and differentiability properties of functions*. Princeton Mathematical Series, No. 30. Princeton University Press, Princeton, N. J., 1970a. [472](#)
- Stein, E. M. *Topics in harmonic analysis related to the Littlewood-Paley theory*. Annals of Mathematics Studies, No. 63. Princeton University Press, Princeton, N. J., 1970b. [242](#), [469](#), [475](#), [480](#), [575](#)
- Stein, E. M. The development of square functions in the work of A. Zygmund. *Bull. Amer. Math. Soc. (N.S.)*, 7(2):359–376, 1982. [345](#)
- Stone, M. H. On one-parameter unitary groups in Hilbert space. *Ann. Math. (2)*, 33:643–648, 1932. [547](#)
- Štrkalj, Ž. and L. W. Weis. On operator-valued Fourier multiplier theorems. *Trans. Amer. Math. Soc.*, 359(8):3529–3547, 2007. [246](#)
- Suárez, J. and L. W. Weis. Interpolation of Banach spaces by the γ -method. In *Methods in Banach space theory*, volume 337 of *London Math. Soc. Lecture Note Ser.*, pages 293–306. Cambridge Univ. Press, Cambridge, 2006. [346](#)
- Suárez, J. and L. W. Weis. Addendum to “Interpolation of Banach spaces by the γ -method”. *Extracta Math.*, 24(3):265–269, 2009. [346](#)
- Sudakov, V. N. Gaussian random processes, and measures of solid angles in Hilbert spaces. *Dokl. Akad. Nauk SSSR*, 197:43–45, 1971. [357](#)
- Szarek, S. J. On the best constants in the Khinchin inequality. *Studia Math.*, 58(2):197–208, 1976. [48](#), [49](#)
- Talagrand, M. Cotype of operators from $C(K)$. *Invent. Math.*, 107(1):1–40, 1992a. [148](#), [249](#)
- Talagrand, M. Cotype and $(q, 1)$ -summing norm in a Banach space. *Invent. Math.*, 110(3):545–556, 1992b. [148](#)
- Talagrand, M. *Upper and lower bounds for stochastic processes*, volume 60 of *Ergebnisse der Mathematik und ihrer Grenzgebiete. 3. Folge*. Springer-Verlag, Heidelberg, 2014. [148](#)
- Tanabe, H. *Equations of evolution*, volume 6 of *Monographs and Studies in Mathematics*. Pitman (Advanced Publishing Program), Boston, Mass., 1979. [546](#)
- Tanabe, H. *Functional analytic methods for partial differential equations*, volume 204 of *Monographs and Textbooks in Pure and Applied Mathematics*. Marcel Dekker Inc., New York, 1997. [546](#)
- Tomczak-Jaegermann, N. The moduli of smoothness and convexity and the Rademacher averages of trace classes $S_p(1 \leq p < \infty)$. *Studia Math.*, 50:163–182, 1974. [146](#)

- Tomczak-Jaegermann, N. Dualité des nombres d'entropie pour des opérateurs à valeurs dans un espace de Hilbert. *C. R. Acad. Sci. Paris Sér. I Math.*, 305(7):299–301, 1987. [357](#)
- Tomczak-Jaegermann, N. *Banach-Mazur distances and finite-dimensional operator ideals*, volume 38 of *Pitman Monographs and Surveys in Pure and Applied Mathematics*. Longman, Harlow, 1989. [148](#), [153](#)
- Torre, A. de la. A simple proof of the maximal ergodic theorem. *Can. J. Math.*, 28:1073–1075, 1976. [575](#)
- Vakhania, N. N., V. I. Tarieladze, and S. A. Chobanyan. *Probability distributions on Banach spaces*, volume 14 of *Mathematics and its Applications*. D. Reidel Publishing Co., Dordrecht, 1987. [46](#), [147](#), [348](#), [355](#)
- Venni, A. A counterexample concerning imaginary powers of linear operators. In *Functional analysis and related topics, 1991 (Kyoto)*, volume 1540 of *Lecture Notes in Math.*, pages 381–387. Springer-Verlag, Berlin, 1993. [469](#)
- Venni, A. Marcinkiewicz and Mihlin multiplier theorems, and R -boundedness. In *Evolution equations: applications to physics, industry, life sciences and economics (Levico Terme, 2000)*, volume 55 of *Progr. Nonlinear Differential Equations Appl.*, pages 403–413. Birkhäuser, Basel, 2003. [247](#)
- Veraar, M. C. and L. W. Weis. Estimates for vector-valued holomorphic functions and Littlewood-Paley-Stein theory. *Studia Math.*, 228(1):73–99, 2015. [349](#), [350](#)
- Veraar, M. C. and L. W. Weis. On semi- R -boundedness and its applications. *J. Math. Anal. Appl.*, 363(2):431–443, 2010. [243](#), [244](#)
- Vitse, P. A Besov class functional calculus for bounded holomorphic semigroups. *J. Funct. Anal.*, 228(2):245–269, 2005. [474](#)
- Voigt, J. Abstract Stein interpolation. *Math. Nachr.*, 157:197–199, 1992. [476](#)
- Weis, L. W. A new approach to maximal L_p -regularity. In *Evolution equations and their applications in physical and life sciences (Bad Herrenalb, 1998)*, volume 215 of *Lecture Notes in Pure and Appl. Math.*, pages 195–214. Dekker, New York, 2001a. [244](#), [245](#), [469](#), [475](#)
- Weis, L. W. Operator-valued Fourier multiplier theorems and maximal L_p -regularity. *Math. Ann.*, 319(4):735–758, 2001b. [242](#), [246](#), [248](#), [469](#), [546](#)
- Weis, L. W. The H^∞ holomorphic functional calculus for sectorial operators—a survey. In *Partial differential equations and functional analysis*, volume 168 of *Oper. Theory Adv. Appl.*, pages 263–294. Birkhäuser, Basel, 2006. [468](#)
- Weissler, F. B. Logarithmic Sobolev inequalities and hypercontractive estimates on the circle. *J. Funct. Anal.*, 37(2):218–234, 1980. [50](#)
- Whittle, P. Bounds for the moments of linear and quadratic forms in independent variables. *Teor. Veroyatnost. i Primenen.*, 5:331–335, 1960. [48](#)
- Wiener, N. Differential space. *J. Math. Phys.*, 2:131–174, 1923. [346](#)
- Wolff, P. Hypercontractivity of simple random variables. *Studia Math.*, 180(3):219–236, 2007. [48](#)

- Xu, Q. H^∞ functional calculus and maximal inequalities for semigroups of contractions on vector-valued L_p -spaces. *Int. Math. Res. Not. IMRN*, 14: 5715–5732, 2015. [476](#), [484](#), [575](#)
- Yagi, A. Coïncidence entre des espaces d'interpolation et des domaines de puissances fractionnaires d'opérateurs. *C. R. Acad. Sci. Paris Sér. I Math.*, 299(6):173–176, 1984. [469](#)
- Yagi, A. *Abstract parabolic evolution equations and their applications*. Springer Monographs in Mathematics. Springer-Verlag, Berlin, 2010. [546](#)
- Yaroslavstev, I. Fourier multipliers and weak differential subordination of martingales in UMD Banach spaces. *arXiv:1703.07817*, 2017. *Studia Math.* (to appear). [248](#)
- Yosida, K. On the differentiability and the representation of one-parameter semi-group of linear operators. *J. Math. Soc. Japan*, 1:15–21, 1948. [547](#)
- Young, R. M. *An introduction to nonharmonic Fourier series*. Academic Press Inc., San Diego, CA, first edition, 2001. [351](#)
- Zimmermann, F. On vector-valued Fourier multiplier theorems. *Studia Math.*, 93(3):201–222, 1989. [246](#)
- Zwart, H. Toeplitz operators and \mathcal{H}_∞ calculus. *J. Funct. Anal.*, 263(1): 167–182, 2012. [475](#)
- Zygmund, A. On the convergence and summability of power series on the circle of convergence. I. *Fund. Math.*, 30:170–196, 1938. [241](#)
- Zygmund, A. *Trigonometric series. Vol. I, II*. Cambridge Mathematical Library. Cambridge University Press, Cambridge, third edition, 2002. [52](#)

Index

- $C_b(E)$, 488
 $D(A)$, 519
 $\Delta_{p,X}$, 136
 $H^{2,p}(\mathbb{R}; X)$, 543
 $H^p(\mathbb{S}_\vartheta)$, 549
 $H^p(\Sigma_\sigma)$, 369, 552
 $H^p(\Sigma_\sigma^{\text{bi}})$, 449
 $K_{p,X}$, 109
 K_N^N , 109
 $L^{p,q}(S)$, 515
 $M_{\sigma,A}$, 369
 $M_{\sigma,A}^\infty$, 381
 $M_{\sigma,A}^\gamma$, 399
 $M_{\sigma,A}^R$, 399
 $N(A)$, 519
 $R(A)$, 519
 $R(\lambda, A)$, 519
 Σ_ω , 360, 536
 $\Sigma_\omega^{\text{bi}}$, 446
 $W^{s,p}(D; X)$, 231
 $X_{\mathbb{R}}$, 494
 $\alpha_{p,X}$, 131
 $\alpha_{p,X}^+$, $\alpha_{p,X}^-$, 132
 $\beta_{p,X}$, 99
 $\beta_{p,X}^+$, $\beta_{p,X}^-$, 113
 $c_{q,X}$, 54
 c_0 , 27, 40, 41
 $\gamma_N^p(X)$, 26
 $\gamma^p(X)$, 26
 $c_{q,X}^\gamma$, 67
 e_k , 43
 $\varepsilon_N^p(X)$, 26
 $\varepsilon^p(X)$, 26, 116
 $\zeta(z) = \frac{z}{(1+z)^2}$, 371, 373
 $\zeta_n(z) = \frac{n}{n+z} - \frac{1}{1+nz}$, 375
 f^* , 515
 $\kappa_{q,p}$, 17
 $\kappa_{q,p,X}^{\mathbb{R}}$, 18
 $\kappa_{q,p}^\gamma$, 18
 ℓ_N^1 , 96
 ℓ_N^∞ , 96
 ℓ_N^p , 96, 562
 $\varrho(A)$, 519
 $\sigma(A)$, 519
 $\tau_{p,X}$, 54
 $\tau_{p,X}^{\mathbb{R}}$, 56
 $\tau_{p,X}^\gamma$, 67
 $[w]_{A_p}$, 185, 577

- $\omega(A)$, 361
- $\omega^{\text{bi}}(A)$, 447
- $\omega_R(A)$, 399
- $\omega_\gamma(A)$, 399
- $\omega_{H^\infty}(A)$, 379

- absolute functional calculus, 478
- abstract Cauchy problem, 523
 - inhomogeneous, 531
- adjoint
 - operator, 522
 - semigroup, 529
- almost R -sectorial, 470
- analytic C_0 -semigroup, 536
- angle
 - of bisectoriality, 447
 - of R -sectoriality, 399
 - of sectoriality, 361
 - of the H^∞ -calculus, 379
- anisotropic size, 247

- B -convex, 151
- ball multiplier, 241
- Banach function space, 515
- Banach lattice, 511
 - p -convex, 161
 - q -concave, 161
- Banach space
 - B -convex, 151
 - complex, 494
 - containing ℓ_N^p uniformly, 96
 - cotype q , 54
 - Gaussian cotype q , 67
 - Gaussian type p , 67
 - isomorphic copy, 60
 - K -convex, 109
 - Pisier's contraction property, 130, 144
 - property (α) , 157
 - property (Δ) , 136
 - real, 494
 - reflexive, 367
 - triangular contraction property, 136
 - type p , 54
 - UMD, 99, 391, 441
- Walsh type, 154
- ξ -cotype q , 67
- ξ -type p , 67
- Banach–Mazur distance, 153
- basis
 - conditional, 394
 - unconditional, 394
- Bessel sequence, 350
- bisectorial operator, 363, 447
- Bonami inequality, 20
- bounded analytic C_0 -semigroup, 537
- bounded imaginary powers, 471
- bounded in probability, 39
- bounded variation, 193
- boundedness constant of the H^∞ -calculus, 381
- Brownian motion, 272

- C_0 -group, 524
 - and bisectoriality, 448
 - and transference, 456
 - Stone's theorem, 544
- C_0 -semigroup, 524
 - adjoint, 529
 - analytic, 536
 - analytic contraction, 537
 - bounded analytic, 537
 - contraction, 534
- Calderón reproducing formula, 372, 383
- Cauchy in probability, 488
- central limit theorem, 504
 - applications, 157
- characteristic function, 493
 - of a complex Gaussian, 498
 - of a real Gaussian, 496
- complex-symmetric random variable, 4
- concave Banach lattice, q -, 161
- conditional basis, 394
- cone, 90
- conical square function, 472
- constant
 - Grothendieck, 242
 - Kahane–Khintchine, 17

- containing ℓ_N^p uniformly, 96
- contraction principle, 9, 220
- convergence
 - in $\gamma(H, X)$, 261
 - in distribution, 488
 - in probability, 488
 - weak, 502
- convergence property
 - of the H^∞ calculus, 381
 - of the Dunford calculus, 370
- convex Banach lattice, p -, 161
- core (for an operator), 526
- cotype, 54
 - finite, 55
 - Gaussian, 67
 - with respect to ξ , 67
- covariance domination, 16, 293
- covariance matrix, 499
- cylindrical distribution, 347

- Davies–Gaffney estimates, 477
- densely defined, 521
- diagonal projection, 214
- diffusion semigroup, 475, 480
- dilation, 561
- discrete heat semigroup, 19
 - hypercontractivity, 19
- discrete Hilbert transform, 137
- distribution, 3, 491
 - cylindrical, 347
- domain
 - Jordan, 224
 - of an unbounded operator, 519
 - plump, 231
 - Stolz, 472
- dual Banach space, 494
- Dunford calculus, 369
 - convergence property, 370
 - extended, 378
 - multiplicativity, 370
 - of a bisectorial operator, 449
 - of a sectorial operator, 370

- Enflo-type, 152
- entropy number, 357

- expectation, 3

- factorisation
 - of $(q, 1)$ -summing operators, 75
 - of R -bounded sets through Hilbert spaces, 250
- finite cotype, 55
 - \Leftrightarrow fails to contain ℓ_N^∞ , 96
 - and $\sum \gamma_n x_n$ versus $\sum \varepsilon_n x_n$, 85
- Fourier multiplier, 192
- functional calculus
 - H^∞ , 379
 - absolute, 478
 - Dunford, 369
 - Phillips, 452

- γ -boundedness, 165
- γ -radonifying operator, 257, 352
- γ -summing operator, 255, 352
- Gaussian
 - cylindrical distribution, 347
 - random variable, xxi, 496, 497
 - standard, 496
 - sequence, 6
- generator, 524
- greatest lower bound, 511
- Grothendieck constant, 242
- group (of operators), 524

- H^∞ -calculus, 379, 381, 450
 - \Leftarrow square function bounds, 421, 429
 - \Rightarrow square function bounds, 415, 426
 - and R -sectoriality, 401
 - and contraction semigroups, 389
 - bisectorial, 449
 - examples, 388
 - of the Laplacian, 391, 441
 - quadratic, 432
 - uniqueness, 382
- Haar basis, 273
- Hardy space
 - on a sector, 552
 - on a strip, 549
- heat kernel, 543
- heat semigroup

- discrete, 19
- generator of, 543
- R -analyticity of, 185, 196
- Hilbert sequence, 338, 342
- Hilbert space
 - \Leftrightarrow Fourier type 2, 94
 - \Leftrightarrow type and cotype 2, 89
 - \Leftrightarrow uniformly bounded sets are R -bounded, 235
- Hilbert system, 337
- Hilbert transform, discrete, 137
- Hilbert–Schmidt operator, 258
- Hodge–Dirac operator, 448, 473
- hypercontractivity
 - of the discrete heat semigroup, 19
 - of the Poisson semigroup, 50
- ideal (in a Banach lattice), 512
- ideal property
 - of γ -radonifying operators, 260
- identically distributed, 7
- imaginary powers of $-\Delta$, 441, 444
- independence, 7, 491
- inequality
 - Bonami, 20
 - Chebyshev, 39
 - Kahane–Khintchine, 21, 23
 - Khintchine, 22
 - Lévy, 8
 - Paley–Zygmund, 25
 - Stein, conditional expectations, 172
- infinitesimal generator, 524
- integral operator, Pettis, 275
- interpolating sequence, 551
- isomorphic copy, 60
- Jordan domain, 224
- K -convex, 109
 - \Leftrightarrow non-trivial type, 124
 - applications, 114, 140, 149
 - with respect to ξ , 121
- Kahane contraction principle, 9
- Kahane–Khintchine constant, 17
- Krivine calculus, 86, 512
- ℓ^s -boundedness, 184, 465
- lacunary sequence, 43
- Laplace transform, 220, 227, 532
 - inverse, for analytic semigroups, 537
- Laplacian
 - as a sectorial operator, 363
 - generates the heat semigroup, 543
 - H^∞ -calculus of, 391
 - imaginary powers of, 441, 444
- lattice homomorphism, 512
- lattice isomorphism, 512
- least upper bound, 511
- Lebesgue point, strong, 304
- lemma
 - Borel–Cantelli, 487
 - covering, 173
 - γ -Fatou, 295
- Lévy multiplier, 248
- linear operator, 519
- locally finite, 303
- locally integrable, strongly, 304
- Lorentz space, 515
 - and factorisation of $(q, 1)$ -summing operators, 75
- maximal L^p -regularity, 531, 546
- mean value, 3
- measurable seminorm, 348
- measure, locally finite, 303
- metric cotype, 153
- metric measure space, 303
- metric type, 152
- mild solution, 546
- modulus in a Banach lattice, 511
- Muckenhoupt A_p class, 185, 577
- multiplicativity
 - of the Dunford calculus, 370
- multipliers
 - Fourier, 192
 - pointwise, R -boundedness of, 170
- non-increasing rearrangement, 515
- non-linear type, 152
- non-trivial type, 55
 - \Leftrightarrow B -convex, 151

- $\Leftrightarrow K$ -convex, 124
 - \Leftrightarrow fails to contain ℓ_N^1 , 96
- off-diagonal bounds, 477
- operator
 - adjoint, 522
 - almost R -sectorial, 470
 - bisectorial, 363, 447
 - Fourier multiplier, 192
 - γ -sectorial, 399
 - γ -radonifying, 257, 352
 - γ -summing, 255, 352
 - Hilbert–Schmidt, 258
 - Hodge–Dirac, 448, 473
 - lattice homomorphism, 512
 - p -summing, 354
 - positive (Hilbertian sense), 388
 - positive (lattice sense), 512
 - power bounded, 471
 - (q, p) -summing, 74
 - R -bisectorial, 447
 - R -sectorial, 399
 - Ritt, 471
 - sectorial, 360
 - self-adjoint, 388
 - and H^∞ -calculus, 388
 - and Stone’s theorem, 544
 - summing, 74, 354
- part (of an operator), 365, 530
- Pettis integral operator, 275
- Phillips calculus, 452
- Pisier’s contraction property, 130
 - duality, 140
 - Gaussian version, 144
- plump domain, 231
- Poisson formula
 - for the disc, 224
 - for the sector, 407
- Poisson semigroup, 50
- polar decomposition, 6
- positive
 - element, 511
 - operator, 512
- power bounded, 471
- principal ideal, 512
- property
 - (Δ) , 136
 - (α) , 157
 - Pisier’s contraction, 140
 - triangular contraction, 136
- quadratic H^∞ -calculus, 432
- quadratic estimates, 430
- R -bisectorial operator, 447
- R -boundedness, 165
 - and duality, 211, 213
 - of averaging operators, 172
 - of convex hulls, 180
 - of functions with integrable derivative, 221
 - of H -valued extensions, 174
 - of holomorphic functions, 222, 224
 - of L^1 -integral means, 218
 - of L^r -integral means, 225
 - of L^∞ -integral means, 219
 - of Laplace transforms, 220, 227
 - of Sobolev functions, 233
 - via domination, 171, 184
 - via the Poisson formula, 224
 - vs. γ -boundedness, 166, 237
 - vs. uniform boundedness, 166, 234
 - vs. weighted inequalities, 191
- R -sectorial operator, 399
- R -sectorial operator
 - vs. H^∞ -calculus, 401
- Rademacher projection, 33, 111
- Rademacher sequence, 5
- Rademacher variable, xxi, 5
- Radon
 - cylindrical distribution, 347
 - measure, 348
 - weak*, 353
- radonification problem, 347
- random variable, 2
 - Banach space-valued, 487
 - complex-symmetric, 4
 - Gaussian, xxi, 496
 - metric space valued, 487

- Rademacher, [xxi](#)
- real-symmetric, [4](#)
- stable, [150](#)
- standard Gaussian, [496](#), [497](#)
- symmetric, [4](#)
- tight, [37](#)
- randomisation, [7](#)
- real-symmetric random variable, [4](#)
- reflexive, [367](#)
- reproducing formula
 - Calderón, [372](#), [383](#)
- resolvent, [360](#), [519](#)
 - as Laplace transform, [532](#)
- resolvent identity, [367](#), [519](#)
- Riesz product, [43](#)
- Riesz sequence, [350](#)
- Ritt operator, [471](#)

- Schauder basis, [392](#)
- Schauder functions, [327](#)
- sector, [360](#), [536](#)
- sectorial operator, [360](#)
 - bi-, [447](#)
 - examples of, [362](#)
 - γ -, [399](#)
 - ω -, [361](#)
 - R -, [399](#)
- sectoriality constant, [369](#)
- self-adjoint, [544](#)
- semi- R -bounded, [244](#)
- semigroup
 - C_0 -, [524](#)
 - diffusion, [475](#)
 - strongly measurable, [528](#)
 - weakly continuous, [527](#)
- Sidon set, [43](#)
- Sobolev space, [231](#), [271](#)
 - embedding into $\gamma(I; X)$, [321](#)
 - R -bounded range, [233](#)
- solution
 - mild, [546](#)
 - weak, [531](#)
- spectrum, [360](#), [519](#)
- square function
 - conical, [472](#)
 - continuous, [423](#)
 - discrete, [414](#)
 - dual, [423](#)
 - in L^q , [28](#)
 - in Banach lattices, [86](#)
 - norm, [253](#), [286](#)
 - Stein's quote on, [251](#)
- stable random variable, [150](#)
- stable type, [150](#), [350](#)
- Steinhaus variable, [xxi](#), [5](#)
- Stokes operator, [477](#)
- Stolz domain, [472](#)
- strong law of large numbers, [147](#)
- strongly measurable semigroup, [528](#)
- summing operator
 - (q, p) -, [74](#)
 - p -, [354](#)
- support, topological, [303](#)
- symmetric diffusion semigroup, [480](#)
- symmetric random variable, [4](#)

- tent spaces, [243](#), [473](#)
- theorem
 - Akcoglu maximal ergodic, [463](#), [569](#)
 - Akcoglu–Sucheston, [562](#), [574](#)
 - Beck, [147](#)
 - Bessaga–Pelczyński, [41](#)
 - Bourgain–Milman–Wolfson, [152](#)
 - Buckley, [578](#)
 - central limit, [504](#), [505](#)
 - applications, [23](#), [157](#)
 - Coifman–Weiss, [456](#), [459](#)
 - covariance domination, [16](#), [293](#)
 - Fourier multiplier, [197](#), [199](#)
 - anisotropic, [247](#)
 - on product space, [205](#), [207](#)
 - R -bounded families, [199](#), [208](#)
 - Franks–McIntosh, [554](#)
 - γ -dominated convergence, [294](#)
 - γ -extension, [308](#)
 - γ -Fubini, [296](#), [297](#)
 - γ -multiplier, [300](#)
 - Guerre–Delabrière, [441](#)
 - Haak–Haase and Le Merdy, [432](#)
 - Haak–Kunstmann, [312](#)

- Hieber–Prüss, 461, 462
- Hille–Yosida, 534
- Hinrichs, 154
- Hoffmann–Jørgensen–Kwapień, 40
 - applications, 118, 119
- Itô–Nisio, 33
- Kahane contraction principle, 9, 47
- Kahane–Khintchine, 21, 23
- Kakutani, 512
- Khintchine–Maurey, 86
 - and characterisation of γ , 289
 - proof in K -convex case, 149
- König–Tzafriri, 64
- Kwapień, on type and cotype 2, 89
 - corollary on Fourier type 2, 94
 - other applications, 177, 236, 281
- Kwapień–Szymański, 356
- Lévy, 502
- Le Merdy, 431, 432, 435
- Lizorkin multiplier, 207
- Marcinkiewicz multiplier, 197, 205
- Maurey factorisation, 89
- Maurey–Pisier, 96, 240
 - applications, 115, 139, 143, 329
- McIntosh, 430
- Mendel–Naor, 153
- Mihlin multiplier, 199
- Muckenhoupt, 578
- Naor–Schechtman, 152
- Pisier
 - cotype in Banach lattices, 145
 - factorisation of $(q, 1)$ -summing operators, 75
 - K -convexity vs. type, 124
 - non-linear type vs. type, 152
 - random vs. trigonometric sums, 43
- Rubio de Francia extrapolation, 579
- Sobolev embedding, 233
- spectral theorem, 389
- Stone, 449, 544
- strong law of large numbers, 147
- uniqueness of the characteristic function, 493, 495
- Venni, 199
- tight, 37
 - uniformly, 37, 38
- trace duality, 269, 282
- transference
 - for C_0 -groups, 456
 - for positive contraction semigroups on L^p , 459
- triangular contraction property, 136
- type, 54
 - and R -bounded range, 233
 - and embedding $W^{s,p} \hookrightarrow \gamma$, 322
 - Enflo-, 152
 - Gaussian, 67
 - metric, 152
 - non-linear, 152
 - non-trivial, 55
 - stable, 150
 - Walsh, 154
 - with respect to ξ , 67
- UMD constant, 99
 - one-sided, 113
- unconditional, 394
- uniformly integrable, 490
- uniformly tight, 37, 38
- universe, 129
- variance, 496
- Walsh system, 156
- Walsh type, 154
- weak convergence, 502
- weak solution, 531
- weak*-Radon, 353
- weak*-topology, 522
- weakly continuous semigroup, 527
- weakly in L^p , 275
- weight, 577
- weighted norm estimates, 477
- Yosida approximation, 534