

ISSN (Print) : 2320 – 3765
ISSN (Online): 2278 – 8875

International Journal of Advanced Research in Electrical, Electronics and Instrumentation Engineering

(An ISO 3297: 2007 Certified Organization)

Vol. 2, Special Issue 1, December 2013

Development of Low Power ARM7 Processor Based Adaptive Vibration Controller

Anitha Vasan M V¹, SivaSubba Rao Patange², S.Raja.³, Srinivas K.S⁴

Department of Electronics and Communication Engineering, School of Engineering & Technology, Jain University,
Bangalore, India^{1,4}

CSIR NATIONAL AEROSPACE LABORATORIES, Bangalore, India^{2,3}

Abstract: The purpose of this paper is to present an adaptive algorithm approach to control the vibrations of an aircraft structure and also use low power based system by real time implementation of the adaptive algorithm using ARM7 LPC2148 Processor. The adaptive algorithm used is Least Mean Square (LMS) the method used is steepest descent. LMS algorithm is an effective algorithm to reduce the vibrations and it does not require complex computations hence complexity of the system is reduced. The KEIL micro vision4 software is used. The programming language used is embedded C. The power consumption comparison of the ARM7 processor with other DSP processors is done.

Keywords: ARM processor, vibration control, LMS, Adaptive control

I. INTRODUCTION

Power consumption has become a major design consideration for battery-operated, portable systems as well as high-performance, desktop systems. Strict limitations on power dissipation must be met by the designer while still meeting higher computational requirements. A comprehensive approach is thus required at all levels of system design, ranging from algorithms and architectures to the logic styles and the underlying technology. Low power processors are cost effective and it helps to reduce the complexity of the system. [1].

Vibration is a mechanical phenomenon whereby oscillations occur about an equilibrium point. Vibration can cause damage or compromise precision instruments and human health, especially for operators of heavy equipment In aerospace sector, vibration results in material fatigue lower than optimal performance characteristics and limited pilot flying times. Elimination of vibrations may improve process accuracies, aircraft performance, pilot flying times and prevent damage. Undesirable vibrations can be attenuated using both passive and active damping techniques. Passive vibration control methods usually use techniques which increase the weight of the aircraft, such as the addition of isolating spring, dampers or material design. The passive techniques do not always provide sufficient bandwidth or attenuation to damp vibrations while active methods which create nullifying disturbances are promising [2].

The Least Mean Square (LMS) algorithm is an adaptive algorithm, which uses a gradient-based method of steepest decent. LMS algorithm uses the estimates of the gradient vector from the available data. LMS incorporates an iterative procedure that makes successive corrections to the weight vector in the direction of the negative of the gradient vector which eventually leads to the minimum mean square error compared to other algorithms LMS algorithm is relatively simple; it does not require correlation function nor does it require matrix inversion[3].

The LPC2148 microcontrollers are based on a 16-bit/32-bit ARM7TDMI-S CPU with real time emulation is used for the implementation of the LMS algorithm to control the vibrations of an aircraft structure which is caused due to the engines. In the LMS algorithm the co-efficient of the filter are modified to control the vibrations. The development platform for this work is in KEIL micro vision 4 and the program was written using embedded C. In this work, the aircraft structure vibrations are controlled using LMS algorithm and it is implemented on an ARM7 processor to obtain a low power based system.

International Journal of Advanced Research in Electrical, Electronics and Instrumentation Engineering

(An ISO 3297: 2007 Certified Organization)

Vol. 2, Special Issue 1, December 2013

II BACKGROUND

Normal and abnormal vibrations occur for several reasons. Aerodynamics, mechanical malfunctions, and external factors such as atmospheric turbulence can cause airplane vibration. All vibrations have associated frequencies and magnitudes that may be readily detected or barely perceptible to the flight crew and passengers. For some vibrations, such as those associated with engine operation, the flight crew has dedicated instrumentation to measure magnitude. Other vibrations are detected by sight, sound, or feel and may depend on flight crew experience for analysis.

Normal Vibrations: Each airplane structural component has a unique signature of normal vibration. This is a consequence of mass distribution and structural stiffness that result in vibration modes at certain frequencies. When external forces act on the airplane, such as normal airflow over the surfaces, very-low-level vibrations result. More noticeable, but also normal, is the reaction of the airplane to turbulent air, in which the magnitude of the vibration may be larger and thus clearly visible and felt. Engine operation at some spool speeds may result in increased vibration because spool imbalance excites the engine and transmits this vibration throughout the airframe. Finally, the operation of some mechanical components, such as pumps, may be associated with normal noise and vibration.

Abnormal Vibrations: The most easily identified abnormal vibration is that which has a sudden onset and may be accompanied by noise. When the onset of abnormal vibration can be associated with a previous action or event, the source may be obvious. However, some vibrations initially are rather subtle and require diagnostic procedures to determine their probable causes. Abnormal vibration usually is related to one or more of the following causes: engine rotor imbalance, malfunction of mechanical equipment, and airflow disturbances acting over doors or control surfaces that are misrigged or misfaired or that have excessive wear or free play. Abnormal vibration rarely is caused by a structural failure or an unstable power control system [4].

III. PZT(LEAD ZIRCONIUM TITANATE)

PZT, or lead zirconium titanate ($\text{Pb}[\text{Zr}(x)\text{Ti}(1-x)]\text{O}_3$), is one of the world's most widely used piezoelectric ceramic materials. When fired, PZT has a perovskite crystal structure, each unit of which consists of a small tetravalent metal ion in a lattice of large divalent metal ions. In the case of PZT, the small tetravalent metal ion is usually titanium or zirconium. The large divalent metal ion is usually lead. Under conditions that confer a tetragonal or rhombohedral symmetry on the PZT crystals, each crystal has a dipole moment. In a basic sense, if a piezoelectric material is deformed, an electric charge is generated it is known as the piezoelectric effect. The opposite of this phenomenon also holds true: If an electric field is applied to a piezoelectric material, deformation occurs in what is known as the inverse piezoelectric effect [5]. A piezoelectric sensor is a device that uses that uses the piezoelectric effect to measure pressure, acceleration, strain or force converting them to electrical energy.

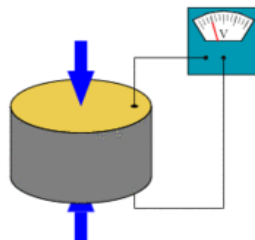

Figure 1: Piezoelectric effect

International Journal of Advanced Research in Electrical, Electronics and Instrumentation Engineering

(An ISO 3297: 2007 Certified Organization)

Vol. 2, Special Issue 1, December 2013

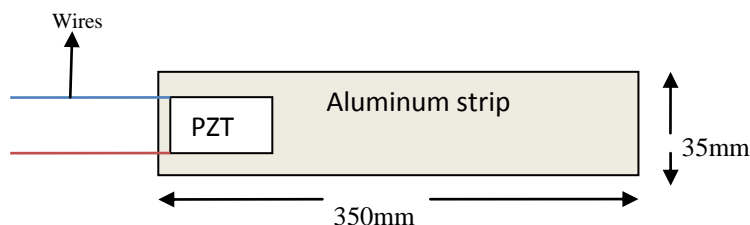

Figure 2: Cantilever Beam generation

PZT actuators convert electrical signals like voltages or charges into mechanical displacements or forces [6]. The operating frequency range of actuators is from static up to about half the resonant frequency of the mechanical system. As for sensors, a reasonably linear relationship between input signal and movement is required [7]. On the other hand, there is the special class of actuators, which is purposely driven at their resonant frequency, known as ultrasonic transducers. These transducers convert electrical energy into mechanical Energy [8]. In this paper cantilever beam with 40x20mm shown in above Figure 2. PZT patch is used one acts as an actuator and the other as sensor is the input fed to the inbuilt ADC of ARM7 LPC2148.

IV. ADAPTIVE ALGORITHM

The Least Mean Square (LMS) algorithm is an adaptive algorithm, which uses a gradient-based method of steepest decent. LMS algorithm uses the estimates of the gradient vector from the available data. LMS incorporates an iterative procedure that makes successive corrections to the weight vector in the direction of the negative of the gradient vector which eventually leads to the minimum mean square error. Compared to other algorithms LMS algorithm shown in figure 3 is relatively simple; it does not require correlation function calculation nor does it require matrix inversions [9].

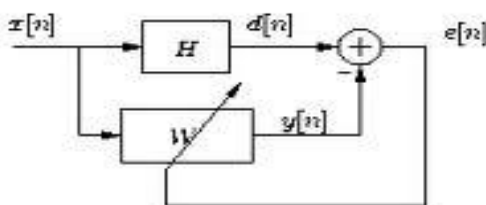

Figure 3: LMS Algorithm

The optimum tap-weights of a transversal (FIR) Wiener filter can be obtained by solving the Wiener-Hopf equation provided that the required statistics of the underlying signals are available. An alternative way of finding the optimum tap-weights is to use an iterative search algorithm that starts at some arbitrary initial point in the tap-weight vector space and progressively moves towards the optimum point in steps. There are many iterative search algorithms derived for minimizing the underlying cost function with the true statistics replaced by their estimate obtained in some manner [10].

Gradient-based iterative methods

- (1) Method of Steepest Descent
- (2) Newton's Method

Assuming that all the signals involved are real-valued signals.

Tap-weight vector $w = [w_0 w_1 \dots w_{N-1}]^T$

Signal input $x^1(n) = [x(n) x(n-1) \dots x(n-N+1)]^T$

Filter output $y(n) = w^T x^1(n)$

Error signal $e(n) = d(n) - y(n)$

International Journal of Advanced Research in Electrical, Electronics and Instrumentation Engineering

(An ISO 3297: 2007 Certified Organization)

Vol. 2, Special Issue 1, December 2013

Performance function $\xi = E[e^2(n)]$

V. IMPLEMENTATION METHOD

In this method the vibrations from the aircraft structure is sensed using PZT sensor but for experimental setup the cantilever beam is used, the detected vibration is voltage signal and it is fed to the inbuilt Analog to digital converter (ADC) of LPC2148. ADC output is fed to LMS algorithm as input $x(n)$, is used to detect the output and the error based on the weight vectors $w(n)$ of the system and input $x(n)$. Error is the difference between the desired input and the output obtained. The weight vectors are updated based on the step size and corrected output is obtained. The output is then fed to the inbuilt Digital to analog converter (DAC) of the LPC2148 and we obtain analog signal which is then fed to the high voltage amplifier. The corrected signal is tested for the aircraft structure to measure the reduction in vibration. Then the power consumed by the ARM 7 processor is computed and compared with the other DSP processor.

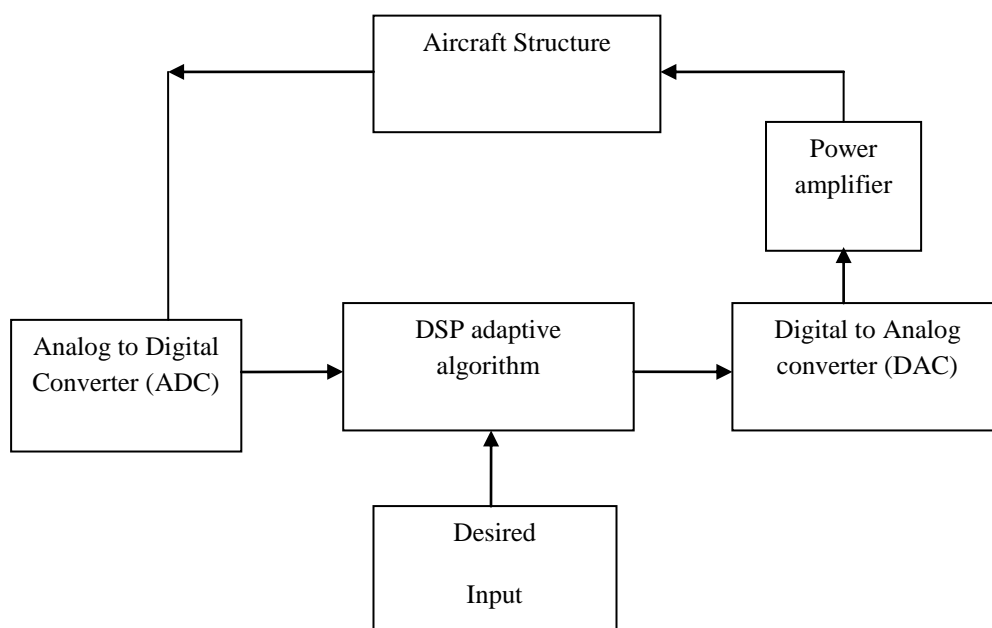

Figure 4: Block diagram of the implementation of adaptive vibration controller

Hardware required stepping down in ADC for LPC2148 the voltage from 5V to 3.3V and stepping up in DAC for LPC2148.

In figure 5 op-amp LM358 is used to step down the voltage range from 5V to 3.3V. We require this extra hardware since the LPC2148 can operate in 3.3V so the step down is necessary, if the step down circuit is not used then the development kit will not operate accurately.

International Journal of Advanced Research in Electrical, Electronics and Instrumentation Engineering

(An ISO 3297: 2007 Certified Organization)

Vol. 2, Special Issue 1, December 2013

ADC step down Circuit using LM358

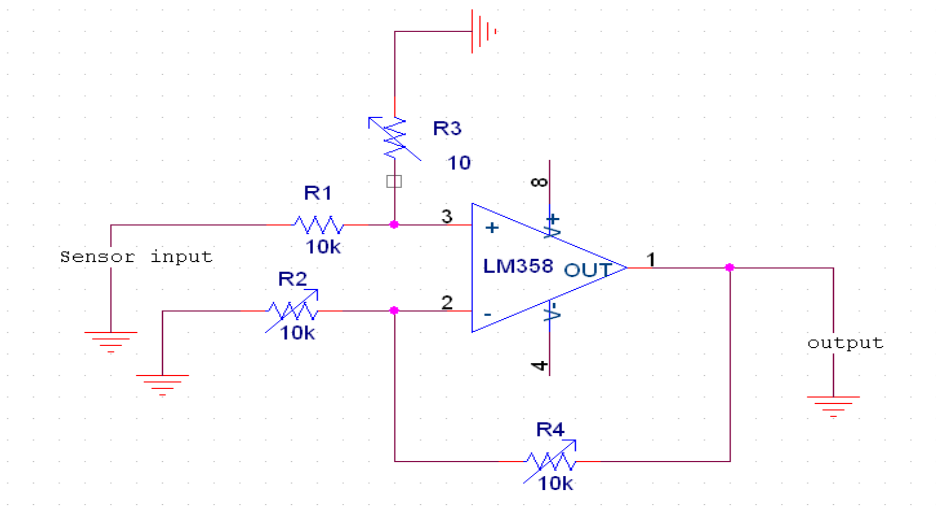

Figure 5: ADC step down circuit

DAC Step Up Circuit using LM358

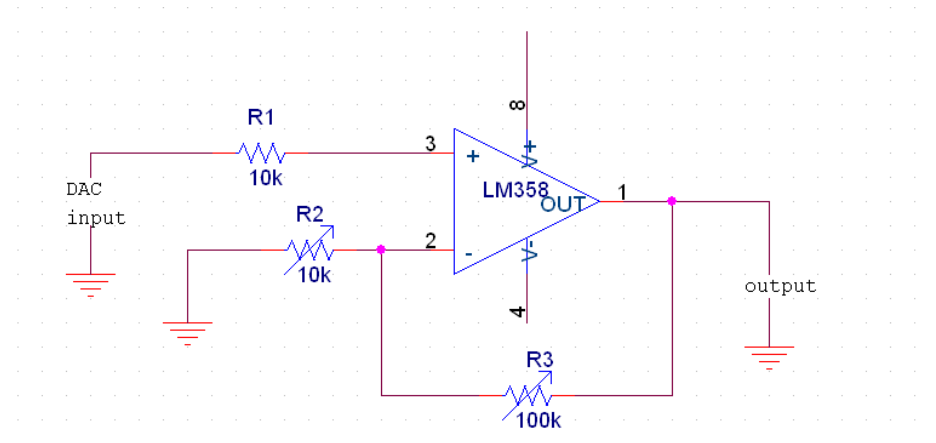

Figure 6: DAC step up circuit

The DAC step up is used to increase the voltage range of the output so the step up is done using op-amp LM358. In this the step up is from 3.3V to 5V the step up is achieved.

VI. RESULTS AND PERFORMANCE ANALYSIS

The LMS adaptive algorithm with ARM 7 processor was implemented and discussed in the previous chapters. Now this chapter deals with simulation results and analog signal obtained in the oscilloscope of the implemented LMS algorithm with ARM 7 processor. Here Keil microvision 4 is used in order to compute the update coefficients.

International Journal of Advanced Research in Electrical, Electronics and Instrumentation Engineering

(An ISO 3297: 2007 Certified Organization)

Vol. 2, Special Issue 1, December 2013

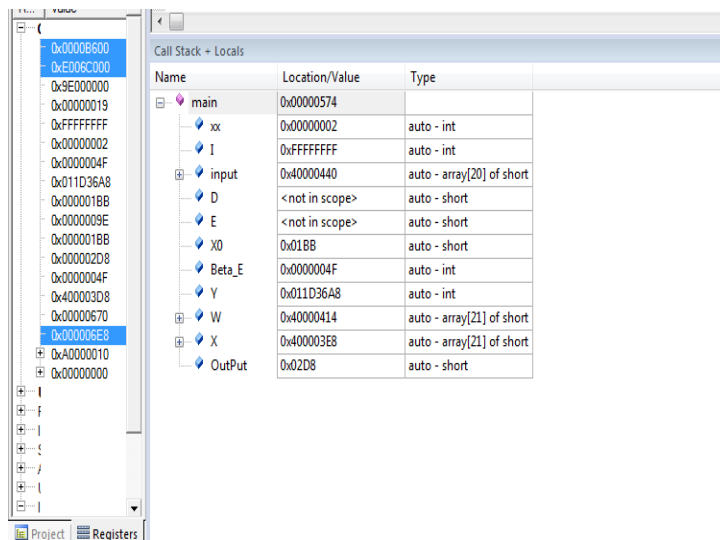

Figure 7: Simulate the Program and we the results are obtained n the hex form

Figure 7 shows the simulated results for the control of vibrations using LMS algorithm using Keil microvision4. Figure 8 shows the result when the input is connected to the power supply the input is indicated by the yellow signal and the controlled vibration is indicated by blue. Figure 9 shows the input which is obtained from the PZT sensor in this indicated by yellow sinusoidal wave in the oscilloscope LeCroy WaveSurfer and the output obtained is the controlled which is indicated in red. Figure 10 is the complete experimental setup of the Adaptive Vibration Controller.

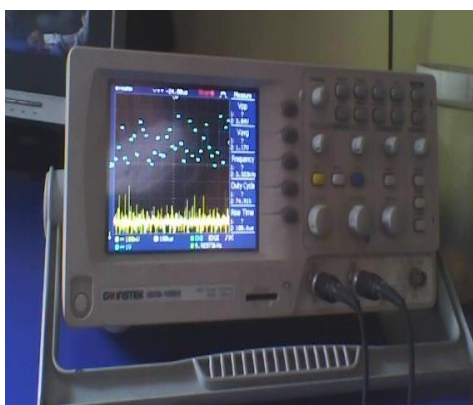

Figure 8: When the ARM 7 Processor is connected to the power supply

International Journal of Advanced Research in Electrical, Electronics and Instrumentation Engineering

(An ISO 3297: 2007 Certified Organization)

Vol. 2, Special Issue 1, December 2013

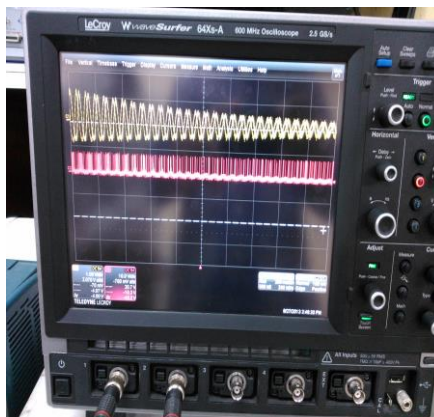

Figure 9: When the ARM processor is connected to the PZT sensor

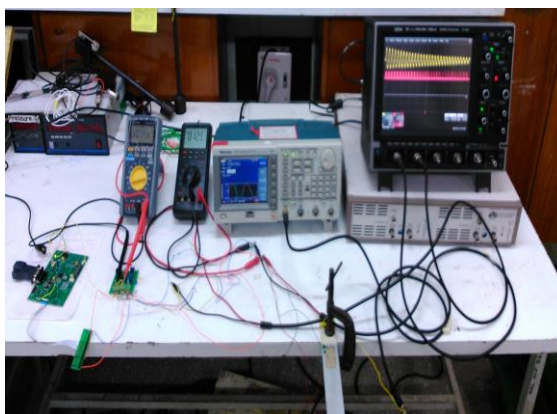

Figure 10: The complete setup of the experiment

TABLE I DAC OUTPUT FOR DIFFERENT FREQUENCY

Frequency(Hz)	DAC output (mV)
1	0.401
2	0.42
3	0.428
4	0.427
5	0.426
6	0.424
7	0.431



International Journal of Advanced Research in Electrical, Electronics and Instrumentation Engineering

(An ISO 3297: 2007 Certified Organization)

Vol. 2, Special Issue 1, December 2013

8	0.44
9	0.433
10	0.446
11	0.46
12	0.44
13	0.45
14	0.461
15	0.431

Table I shows that for different frequencies the DAC output obtained in this table we observe that voltage increases until 14 HZ which is the resonant frequency in this case and after it crosses the resonant frequency the voltage reduces. Table II shows the sensor input and the corresponding DAC output obtained. In this DAC output means the controlled vibrations. The power consumption of the LPC2148 ARM7 the current is 45mA and voltage is 3.3V processor the power consumed in this processor is 148.5 mW. In Table III we can observe that the power consumed by ARM7 LPC2148 is less compared to the DSP processors hence the experiment consumes low power. The values are taken from datasheets of corresponding processors.

TABLE II: SENSOR INPUT AND DAC OUTPUT OBTAINED

Sensor Input (mV)	DAC output (mV)
15	1.3
16	1.4
13	1.2
19	1.5
21	1.31
23	1.4
26	1.1



International Journal of Advanced Research in Electrical, Electronics and Instrumentation Engineering

(An ISO 3297: 2007 Certified Organization)

Vol. 2, Special Issue 1, December 2013

TABLE III POWER COMPARISON OF DIFFERENT PROCESSORS

Processors	Current (mA)	Voltage(V)	Power(mW)
ARM7 LPC2148	45	3.3	148.5
TMS320C6711D (Texas Instruments DSP Processor)	75	3.3	247.5
SAA7715AH (Philips DSP Processor)	95	3.45	327.7
DSP56001 (Motorola)	155	5.5	852.5

VII. CONCLUSION

In this paper LMS algorithm is used to control the vibrations of an aircraft structure is presented. For trails the Aircraft wing considered as a cantilever beam with 40x20mm PZT patch one acts as actuator and the other as a sensor is used. The vibrations on the beam were sensed using PZT sensor. From the results it can be concluded that the use of ARM7 processor is effective for low power based system requirement when compared to other DSP processor.

ACKNOWLEDGMENT

Authors would like to thank Mr. Shyam Chetty, Director CSIR-NAL, Dr. Satish Chandra, Head STTD, CSIR-NAL, for their constant help and encouragement. Prof. Ramesha K, Head of Department, Electronics and Communication, Sri Bhagawan Mahaveer Jain college of Engineering for their constant encouragement to carry out this work.

REFERENCES

- [1] Keshab K Parhi "Approaches to low power implementation of DSP systems" IEEE transactions on circuits and systems Fundamental theory and applications Vol. 48 2001.
- [2] L.J Eriksson "Active Sound and Vibration Control using Adaptive Digital Signal Processing" IEEE International Conference Vol.1 April 1993.
- [3] Gergely Takács, Boris Rohal'-Ilkiv "Algorithms in Active Vibration Control" Model Predictive Vibration Control 2012, pp 105-140
- [4] www.boeing.com/commercial/aeromagazine/aero_16/vibration_story.
- [5] C.Karthikeyan Shashikala Prakash" FxLMS Algorithm with Feedback Neutralization for Active Vibration Control" INSTITUTE OF SMART STRUCTURES AND SYSTEMS (ISSS) J. ISSS Vol. 1 No. 1, pp. 23-33, Sept 2012.
- [6] A. Madkour, M. A. Hossain, K. P. Dahal, and H. Yu "Intelligent Learning Algorithms for Active Vibration Control" IEEE TRANSACTIONS ON SYSTEMS Vol.37 No.5 September 2007
- [7] Sungsoo Na and Liviu I. Librescu "Optimal vibration control of adaptive aircraft wings carrying externally mounted stores and exposed to blast loading", Proc. SPIE 3667, Smart Structures and Materials 1999: Mathematics and Control in Smart Structures, 498 (June 4, 1999);
- [8] Peretz P. Friedmann and Thomas A. Millott. "Vibration reduction in rotorcraft using active control - A comparison of various approaches", Journal of Guidance, Control, and Dynamics, Vol. 18, No. 4 (1995).
- [9] DePriest, J., "Aircraft Engine Attachment and Vibration Control," SAE Technical Paper 2000-01-1708, 2000
- [10] Yousefi-Koma, D G Zimcik "Applications of Smart Structures to Aircraft for Performance Enhancement" Canadian Aeronautics and Space Journal, Vol. 49, No. 4 2003: