

Siemens Westinghouse Advanced Turbine Systems Program Final Summary

Ihor S. Diakunchak

Greg R. Gaul

Gerry McQuiggan

Leslie R. Southall

Siemens Westinghouse Power Corporation,
4400 Alafaya Trail,
Orlando, FL 32826-2399

This paper summarizes achievements in the Siemens Westinghouse Advanced Turbine Systems (ATS) Program. The ATS Program, co-funded by the U.S. Department of Energy, Office of Fossil Energy, was a very successful multiyear (from 1992 to 2001) collaborative effort between government, industry, and participating universities. The program goals were to develop technologies necessary for achieving significant gains in natural gas-fired power generation plant efficiency, a reduction in emissions, and a decrease in cost of electricity, while maintaining current state-of-the-art electricity generation systems' reliability, availability, and maintainability levels. Siemens Westinghouse technology development concentrated on the following areas: aerodynamic design, combustion, heat transfer/cooling design, engine mechanical design, advanced alloys, advanced coating systems, and single crystal (SC) alloy casting development. Success was achieved in designing and full scale verification testing of a high-pressure high-efficiency compressor, airfoil clocking concept verification on a two-stage turbine rig test, high-temperature bond coat/TBC system development, and demonstrating feasibility of large SC turbine airfoil castings. The ATS program included successful completion of W501G engine development testing. This engine is the first step in the W501ATS engine introduction and incorporates many ATS technologies, such as closed-loop steam cooling, advanced compressor design, advanced sealing, and high-temperature materials and coatings.

[DOI: 10.1115/1.1719030]

Introduction

The Advanced Turbine Systems Program co-funded by the U.S. Department of Energy, Office of Fossil Energy, was an ambitious ten-year effort to develop the necessary technologies which will result in a significant increase in natural gas-fired power generation plant efficiencies, decrease in cost of electricity, and a reduction in emissions, while maintaining the current state-of-art reliability, availability, and maintainability (RAM) levels. This three-phase technology development and demonstration program was started in 1992 and was completed in 2001.

The ATS Program objective was to develop ultra-high efficiency, environmentally superior, and cost competitive systems for base load application in utility, independent power producer, and industrial markets. The following specific performance targets were set using natural gas as the primary fuel:

1. system efficiency exceeding 60% (net, lower heating value basis) on natural gas for large scale utility turbine systems; for industrial applications, systems that will result in a 15% improvement in heat rate compared to currently available gas turbine systems.
2. an environmentally superior system that will not require the use of post combustion emissions controls under full load operating conditions.
3. busbar energy costs that are 10% lower than current state-of-the-art turbine systems, while meeting the same environmental requirements.
4. fuel-flexible designs that will operate on natural gas but are capable of being adapted to operate on coal-derived or bio-mass fuels.
5. RAM that is equivalent to the current turbine systems.

6. water consumption minimized to levels consistent with cost and efficiency goals.
7. commercialization in the year 2000.

In Phase 1 of the ATS Program, preliminary investigations on different gas turbine cycles demonstrated that net plant LHV based efficiency greater than 60% was achievable, [1]. In Phase 2 the more promising cycles were evaluated in greater detail and the closed-loop steam-cooled combined cycle was selected for development because it offered the best solution with least risk for achieving the ATS Program goals of plant efficiency, emissions, cost of electricity and RAM, [2]. Phase 2 also involved conceptual ATS engine and plant design and technology developments in aerodynamics, sealing, combustion, cooling, materials, coatings, and casting development, [3,4].

Phase 3 and Phase 3 Extension involved further technology development, component testing and W501ATS engine design. The technology development efforts consisted of ultra low NO_x combustion, catalytic combustion, heat transfer, advanced coating systems, advanced alloys, single crystal casting development, and determining the effect of steam on turbine alloys. Included in this phase was full-load testing of the W501G engine at the McIntosh No. 5 site in Lakeland, FL, [5].

The W501ATS engine incorporates new technologies, as well as design features developed over the last 50 years and employed successfully in the W501 series of heavy-duty industrial and utility engines, [6]. These design features include single-shaft two-bearing rotor, cold-end generator drive, compressor blade rings, individual combustor baskets, low alloy steel rotor discs, curvic clutched turbine rotor, four-stage turbine, cooled and filtered rotor cooling air, single first-stage turbine vane segments, and tangential exhaust struts. The evolution of large gas turbines started at Westinghouse with the introduction of the 45 MW W501A engine in 1968 (see Fig. 1). Continuous enhancements in performance were made up to the 100 MW W501D5, introduced in 1981. The

Contributed by the International Gas Turbine Institute (IGTI) of THE AMERICAN SOCIETY OF MECHANICAL ENGINEERS for publication in the ASME JOURNAL OF ENGINEERING FOR GAS TURBINES AND POWER. Paper presented at the International Gas Turbine and Aeroengine Congress and Exhibition, Amsterdam, The Netherlands, June 3–6, 2002; Paper No. 2002-GT-30654. Manuscript received by IGTI, Dec. 2001, final revision, Mar. 2002. Associate Editor: E. Benvenuti.

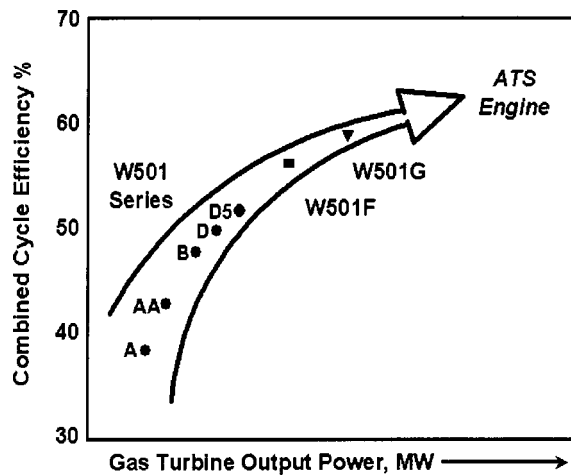

Fig. 1 Evolution of large gas turbines

W501ATS engine is the latest evolutionary design that builds on the success of its predecessors, such as the 186 MW W501F, introduced in 1991, and 250 MW W501G, [7,8].

Siemens Westinghouse's strategy to achieve, and exceed ATS Program goals is to build on the proven technologies used in the successfully operating fleet of its utility gas turbines, such as the W501F, and to extend the technologies developed for the W501G. To help in defining the W501ATS engine and plant, Siemens Westinghouse constituted a 12-member ATS Advisory Board composed of major utilities and independent power producers from the U.S. and U.K. The objective was to ensure that the W501ATS engine will address the customers' needs and find early acceptance in the market place.

Cycle Selection

An extensive study was carried out to select the optimum cost-effective cycle that will achieve the ATS Program goals. The following major cycles were analyzed in considerable detail: increased firing temperature, intercooling, recuperation, intercooling with recuperation, reheat, chemical recuperation, steam injection, and closed-loop steam cooling (CLSC). Based on performance, emissions, cost of electricity and RAM considerations, the cycle selected for the ATS plant consisted of an advanced, high firing temperature, closed-looped steam cooled gas turbine, with a high efficiency bottoming cycle and high efficiency generator.

Technology Development

The main objective of the technology development effort was to develop and verify technologies considered necessary to ATS Program success. To achieve this objective, research was carried out in the following areas: aerodynamics, sealing, combustion, cooling/heat transfer, materials, coatings, and single crystal casting development.

Aerodynamics. High-pressure ratio, high efficiency compressor was designed using the latest three-dimensional viscous code and controlled diffusion airfoils. Variable stators were incorporated into the first two stages to improve starting capability and part-load performance. The mechanical integrity of each stationary and rotating airfoil was verified by finite element analyses to satisfy steady stress and endurance strength criteria. Each airfoil was tuned to avoid potentially harmful resonant frequencies. A plastic model based on the W501F combustion cylinder was constructed to investigate in detail the flow conditions between the compressor exit and the turbine inlet. One of the sixteen combustors was the exact scaled replica of the W501F design while the other combustors simulated the correct combustor pressure loss with the aid of orifices. The model testing and extensive compu-

tational analysis addressed the detail flow distributions around the combustors with and without air extraction for applications in an integrated gasification combined cycle, [9]. Even air flow distributions around the combustor baskets, and hence uniform fuel/air ratios, are very important in achieving ultra low NO_x required in the ATS combustion system.

Sealing. Gas turbine performance is adversely affected by internal leakages. One percent air leakage results in about 1.5% decrease in combined cycle output power and about 0.5% decrease in thermal efficiency. In order to minimize leakages and hence optimize performance, an extensive sealing development program was carried out in the following areas: brush seals, face seals, rope seals, and abradable coatings applied to outer air seal surfaces to allow reduced compressor and turbine blade tip clearances. To reduce air leakage, as well as hot gas ingestion into turbine disk cavities, brush seals will be incorporated under the compressor diaphragms, turbine disk front, turbine rims, and turbine interstage locations. Tests were carried on test rigs for the different brush seal locations to develop effective, rugged, reliable, and long service life brush seal systems. These tests verified the brush seal low leakage and wear characteristics.

A face seal was designed and developed for the rotor rear location in closed-loop rotor cooling applications to prevent rotor cooling air leakage. The noncontacting, dry running face seal has been used in aircraft gas turbines and other turbomachinery applications. Development was necessary to demonstrate that such a seal could meet the requirements of life, durability, large axial movement and turning gear operation in the W501ATS applications. Two full-size prototype seals were designed and tested under simulated engine conditions. Test results showed that the leakage was a fraction of the target value, there was no seal wear and large axial movement could be accommodated.

Considerable performance benefits result from reduced compressor and turbine blade tip clearances. Abradable coatings are being used to reduce tip clearances by allowing minimum build clearances without fear of damaging hardware and by providing more circumferentially uniform tip clearances. Abradable coatings, identified for compressor and turbine applications, were tested to determine abrasability, tip-to-seal wear rate, and erosion characteristics.

Several active turbine blade tip clearance control schemes were investigated. One of them, based on the closed-loop steam cooling concept, showed considerable promise in minimizing the steady-state blade tip clearances, while allowing large clearances on start-up so as to avoid blade tip rubs.

Combustion. To achieve single-digit NO_x emissions at the ATS firing temperature required a considerable development effort, balancing the design for efficiency, emissions, mechanical integrity, and cost. Three different combustor concepts were included in this development. The most successful candidate is the dry low NO_x (DLN) combustor, which consists of eight premixed swirler assemblies arranged around a diffusion/pilot nozzle/swirler assembly. The premixed swirlers are designed to enhance mixing without recirculation, whereas the pilot swirler provides strong swirl to produce a recirculation zone and, hence, good flame stability. The DLN combustor development is concentrated on air management and fuel/air mixing optimization. Although the combustor design allows the pilot to run at very low fuel flows, the pilot is primarily responsible for the NO_x production. To achieve low NO_x levels, a catalytic pilot is being developed to allow operation below the lean extinction limit.

To aid in combustion system development flow visualization tests were carried out on a dry low NO_x combustor using both a single combustor rig and a full-scale sector rig, in order to verify qualitatively CFD predictions. The agreement between the experimental and CFD results was excellent.

Optical diagnostics allow measurement of pertinent parameters, such as the composition and concentration of combustion products

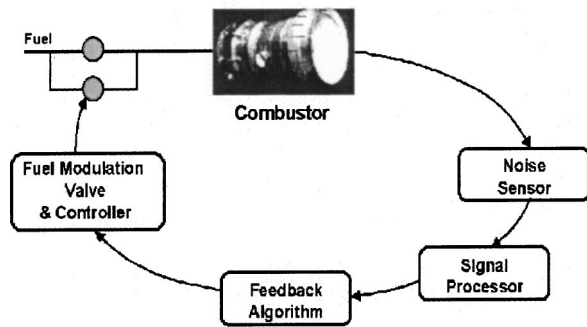

Fig. 2 Active combustion noise control loop

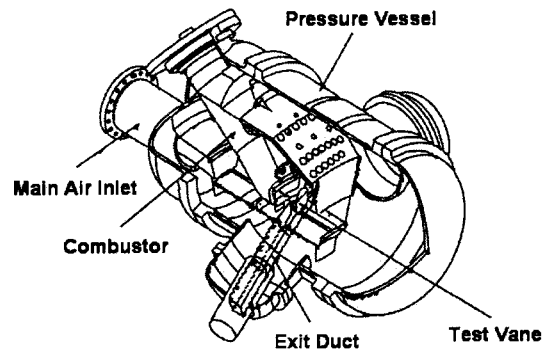

Fig. 3 Cutaway view of vane cascade test rig

in addition to velocities and flow angles, without disturbing the main flow. A laser-induced fluorescence probe was developed. The probe, which will be used in both cold flow and fired tests, will be a very useful tool in enhancing combustion development productivity.

Lean-premix combustion system will be employed to achieve the NO_x emissions goals. The lean combustion with its inherent flame instability results in more combustion generated noise, and hence, in vibration problems in the combustion system as well as in the downstream components. A program to develop the theoretical background for combustion instabilities, to carry out experiments to aid in the understanding of the problem, to develop a generalized analysis procedure, and to develop stability criteria is under way. An active noise control system is being developed to eliminate combustion instabilities. It consists of a sensor to detect the combustion instabilities, signal processor, feedback algorithm generator, and a fuel modulation valve and controller (see Fig. 2).

To ensure that single digit NO_x emissions are achieved a catalytically enhanced combustor development program is being pursued in parallel with other combustion development efforts. Catalytic combustion is expected to play an important role in achieving ultra low NO_x emissions at the ATS engine firing temperature. The catalyst allows ultra lean-premix combustion without flame instability and flame outs. Therefore, NO_x production is restricted to low single digits at ATS firing temperature with stable operation. Development is in progress to gain theoretical understanding of catalytic combustion, to design a catalytic combustion system and to develop a practical catalytic combustor. The catalytic combustor development effort involves lab testing and field testing prior to the components being installed for commercial operation.

Cooling. Closed-loop cooling is the largest contributor to the ATS plant performance. Eliminating cooling air ejection into the turbine gas path raises the gas temperature downstream of the first stage vane, hence increasing the gas energy level during the expansion process and eliminating cooling air mixing losses. Closed-loop cooling provides an additional benefit in NO_x reduction, by making more air available at the combustor inlet for the lean premix combustion, while maintaining the same burner outlet temperature. Without a cooling air film to shield the turbine components from the hot gases and trailing edge cooling air ejection to enhance cooling in the critical trailing edge region, it is quite a challenge to develop a successful closed-loop cooling design. This challenge was overcome in the W501ATS turbine airfoil cooling design by using thin outer wall design concept. In order to verify the critical closed-loop cooled designs, the following development programs were undertaken: outside heat transfer coefficient measurement, internal heat transfer coefficient and pressure loss measurement, and first-stage vane hot cascade test.

The outside heat transfer coefficients on airfoil and endwall surfaces were measured on the model turbine tests performed at Ohio State University. Internal heat transfer coefficients and flow

characterization tests were carried out at Carnegie-Mellon University on the first-stage vane and blade-cooling designs. These tests involved ten plastic models representing six cooling techniques utilized in the various sections of the first stage turbine vane and blade. The transient liquid crystal technique was the primary measurement method. Test results confirmed analytical predictions. The first-stage vane cooling design will be verified at ATS operating conditions in an integrated combustion and hot cascade test rig, located at the Arnold Engineering Development Center, Arnold AFB, TN (see Fig. 3).

Heat transfer development included plastic model tests to measure internal heat transfer coefficients and pressure drops in multipass blade cooling channels and stator airfoil and endwall film cooling. Third-stage turbine blade shroud cooling design was carried out to ensure adequate cooling for the highly stressed portion of the blade.

Materials. ATS operating conditions extend the technology envelope of current materials, hence materials development work is an important element in the evolution and success of the W501ATS engine. To ensure this success, development programs were carried out on the effect of steam cooling on materials, blade life prediction, advanced vane alloy, nickel-based superalloy for rotors, directionally solidified blade alloy properties, and single-crystal material data.

Coatings. Thermal barrier coatings are critical to the mechanical integrity of the W501ATS engine design. An advanced bond coat/TBC system was developed for more than 24,000 hours service life. Different bond coats and ceramic materials were evaluated under accelerated oxidation test conditions and down selected. The advanced bond coat/TBC system mechanical integrity and durability were demonstrated in more than 24,000 hours of cyclic testing at 1010°C (1850°F).

Novel ceramic chemistries were investigated in an effort to improve upon the phase stability and sintering resistance of 8% yttria-stabilized-zirconia TBC. Under a related program, DOE-Oak Ridge National Laboratory Thermal Barrier Coatings Program, new ceramic TBC's have been identified with superior performance. With the selection of a new bond coat, identified earlier in the program, and a new TBC composition, a TBC system is available for application at the estimated ATS airfoil surface temperatures.

An advanced abrasable TBC system was developed under the ATS program. The system was designed for the ATS first-stage turbine ring segment, which forms the outer flow path surface around the first stage turbine blade. In this application, the system requires state-of-the-art thermal barrier properties and sufficient abrasability to prevent excessive blade tip wear. Laboratory component testing verified its ability to withstand high surface temperatures, large thermal gradients, and engine-typical blade incursion. To verify performance in an operating engine, seven first-stage turbine ring segments were installed in an engine. These

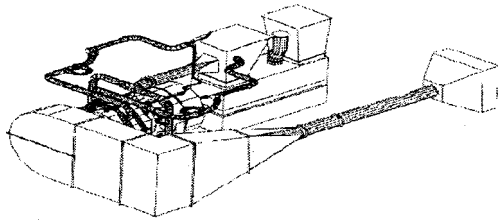

Fig. 4 Compressor test facility

segments were inspected with excellent results after 6000 hours of operation. No detectable erosion or blade tip wear was observed.

Single Crystal Casting Development. To achieve ATS Program performance and mechanical integrity goals, SC vanes and blades are used in the W501ATS engine. Casting development programs were carried out to demonstrate castability of large industrial turbine airfoils in CMSX-4 alloy. Casting trials on first-stage turbine vanes and blades incorporating thin wall cooling design features demonstrated the viability of this concept. Casting trials carried out on the thick-walled second-stage blade and shrouded third-stage blade were also successful. This development effort will be continued to further improve the casting process, and hence improve the yield and make large SC turbine airfoil castings cost effective.

Component Testing

Compressor. To verify the aerodynamic performance and mechanical integrity of the new high-pressure ratio design, the full-scale W501ATS compressor was manufactured and tested in a specially designed facility constructed at the U.S. Navy Base in Philadelphia (see Fig. 4). The compressor test was carried out at subatmospheric inlet conditions to reduce the power required to drive the test compressor to that available at the test facility.

The compressor was instrumented with static pressure taps, fixed temperature and pressure rakes, thermocouples, tip clearance probes, blade vibration monitoring probes, rotor vibration probes, acoustic probes, and strain gages installed on several stages of stators. Provisions were made for radial traverses in eight axial locations in the compressor and four radial locations in the inlet duct. More than 500 individual measurements were recorded. A dedicated data acquisition system was used to collect and reduce the test data. Important performance and health monitoring parameters were displayed on computer screens in real time. After the compressor test facility was commissioned, an extensive test program was performed. The test program included design point performance verification, blade vibration, and diaphragm strain gage measurements, inlet guide vane and variable stator optimization, compressor map definition and starting characteristics optimization. The compressor testing, which was successfully completed ahead of schedule, confirmed all mechanical and aerodynamic performance predictions.

Turbine Testing. The objectives of this development program were the experimental verification of turbine performance with airfoils designed for reduced solidity (and hence reduced cooling requirement) and optimized for closed-loop cooling, performance benefits due to optimum circumferential alignment of turbine airfoils, and airfoil surface heat transfer coefficients. A 1/3 scale model of the first two turbine stages was designed, manufactured, and tested in the shock tube test facility located at Ohio State University (see Fig. 5). Approximately 400 individual sensors were installed on the model turbine, including miniaturized pressure transducers, thermocouples, and thin-film heat flux gages on both stationary and rotating airfoils. Provision was made for exit

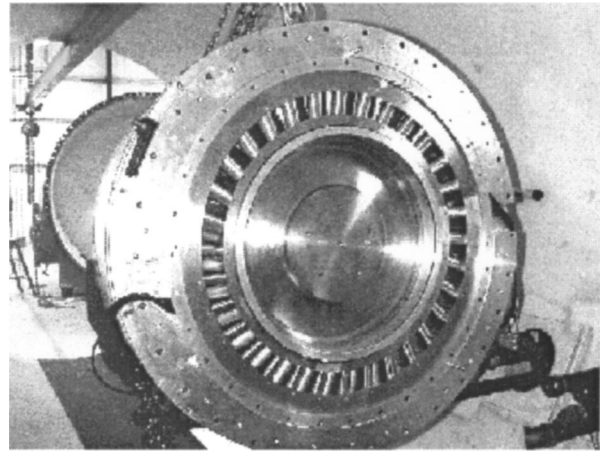

Fig. 5 Model turbine test rig

traversing. Test results confirmed efficiency and heat transfer coefficient predictions and indicated that clocking benefits were greater than expected.

ATS Plant

The ATS plant utilizes a single shaft design concept which incorporates a gas turbine on one end of the generator and a steam turbine on the other (see Fig. 6). The gas turbine is coupled to the generator in the typical manner. However, the steam turbine is coupled to the generator through a self-shifting, and self-synchronizing clutch which is connected to the generator's collector shaft. The gas turbine exhaust passes through the three-pressure level heat recovery steam generator (HRSG) before being exhausted through the stack. The high-pressure steam turbine exhaust steam is utilized to cool the transitions and the first two stages of turbine vanes. The reheated steam is returned to the steam cycle for reheat and induction into the intermediate pressure steam turbine (see Fig. 7).

The two-case multistage single-flow reheat, axial exhaust, condensing steam turbine employs advanced aerodynamic design methods. High-performance bowed impulse and reaction blades are used on the high pressure and intermediate pressure turbines, respectively. Optimized reaction blading is used on the low pressure turbine which includes 1.07 meter (42 in.) long last-stage rotating blades.

The two-pole, 60 Hz, hydrogen inner-cooled generator design absorbs the combined gas turbine and steam turbine power output. The generator operates with static excitation and supports static starting of the gas turbine. To achieve high efficiency, several design enhancements, such as reduced windage and core losses and improved insulation, were incorporated.

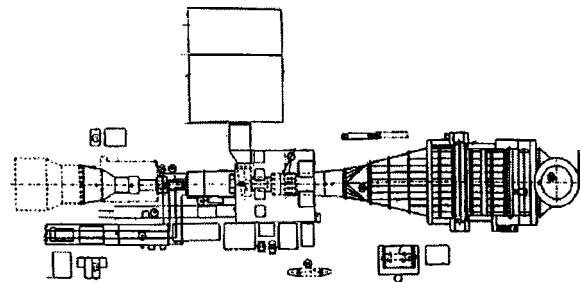

Fig. 6 ATS plant layout

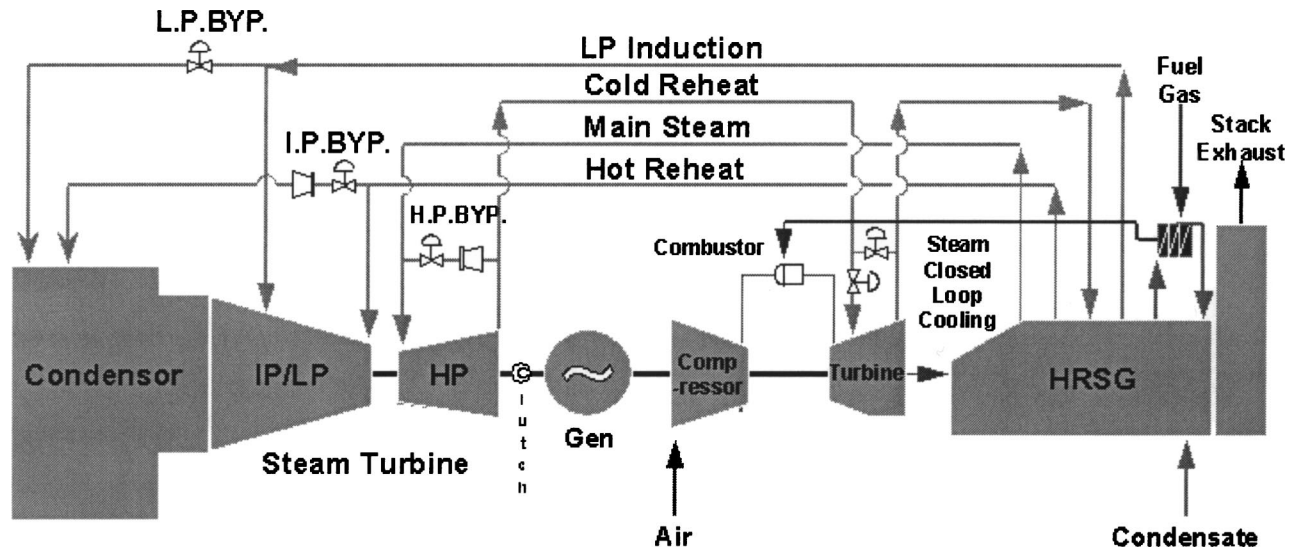

Fig. 7 ATS plant steam system

W501G Engine Development

Siemens Westinghouse solicited input from an industry advisory panel comprised of members from major U.S. and international utilities and independent power producers. Based on the input from this panel and market analyses, Siemens Westinghouse is pursuing an evolutionary introduction of the W501ATS, which incorporates ATS technology in stages culminating in an engine that meets or exceeds all of the program objectives. This approach has two main advantages. First, the evolutionary approach mitigates the risk associated with introducing multiple, advanced technologies simultaneously. Second, the early introduction of ATS technology expands the net benefit of the program, as compared with limiting the technology incorporation to only the W501ATS engine.

The evolutionary approach is shown schematically in Fig. 8. First, the introduction of the ATS frame begins with the 250 MW W501G. This engine is the latest in the series of heavy-duty utility gas turbines and incorporates many ATS technologies. This engine utilizes advanced materials, coatings, cooling technology and advanced aerodynamic design. The 19.5:1 pressure ratio 16-stage compressor, which is derived from the ATS compressor, uses advanced profile high-efficiency airfoils. The combustor design is similar to W501F and hence has the same low NO_x emissions. The 4-stage turbine uses full three-dimensional design airfoils. Brush seals are used in the turbine interstage locations and abradable coatings are used in both the compressor and the turbine to reduce blade tip clearances. Second, from the initial W501G fu-

ture enhancements include steam-cooled turbine vanes, leakage improvements, and increased combustor outlet temperature. Third, the W501ATS engine evolves from the W501G which reduces development risks through early demonstration of many critical technologies.

W501G Test Results. The first W501G was ignited in April 1999, at the City of Lakeland, MacIntosh No. 5 site. The unit has undergone extensive testing and verification. Since March 2000, the customer has dispatched the unit based on power demands. Currently, the unit operates in a simple cycle mode with a once-through-steam-generator for cooling steam production. Construction of the combined cycle plant is underway and will be completed in 2002.

The W501G test program included starting optimization, performance and emissions verification, hot parts metal temperature measurement, including telemetry and thermal paint testing, vibration measurement, tip clearance measurement, etc. The engine instrumentation included over 3000 sensors and measured parameters. An engine schematic showing the various sensors is shown in Fig. 9. The test program consisted of two distinct phases: emissions/performance mapping phase and thermal paint testing. In the emissions/performance mapping phase, testing targeted combustion system variables and provided engine performance mapping from different operating conditions, such as IGV position and exhaust temperature.

Following the initial testing, turbine flowpath and combustion components were painted with thermal paints and installed into the engine. The thermal paint changes colors based on exposed temperature. This method is used extensively in aeroengine validation since it provides a complete and accurate temperature map of the components at operating conditions. To react the thermal paint, the engine was ramped up to full load, run for approximately five minutes at full load and then shut down. The thermal paint test was conducted in two phases. In July 2000, the transitions and first stage turbine vanes were painted and tested. These components are removable without a major cover lift. In October 2000, a full paint test was carried out. This test included all turbine blades and vanes and areas of the rotor subjected to high temperatures. Figure 10 shows the scope of the painted components. Both tests were conducted successfully and results were evaluated in great detail to verify the hot parts' cooling design and to validate computer codes used in W501G engine design. The testing validated the transition duct closed-loop steam cooling in a commercial application.

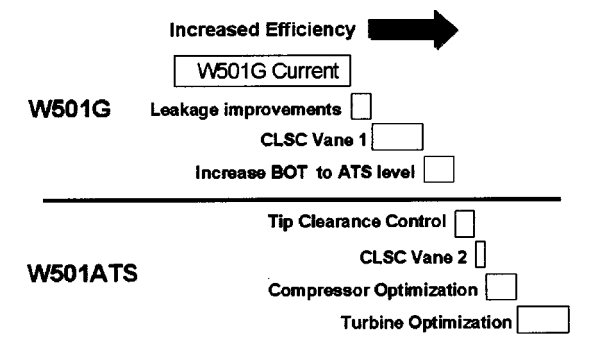

Fig. 8 W501ATS engine evolution

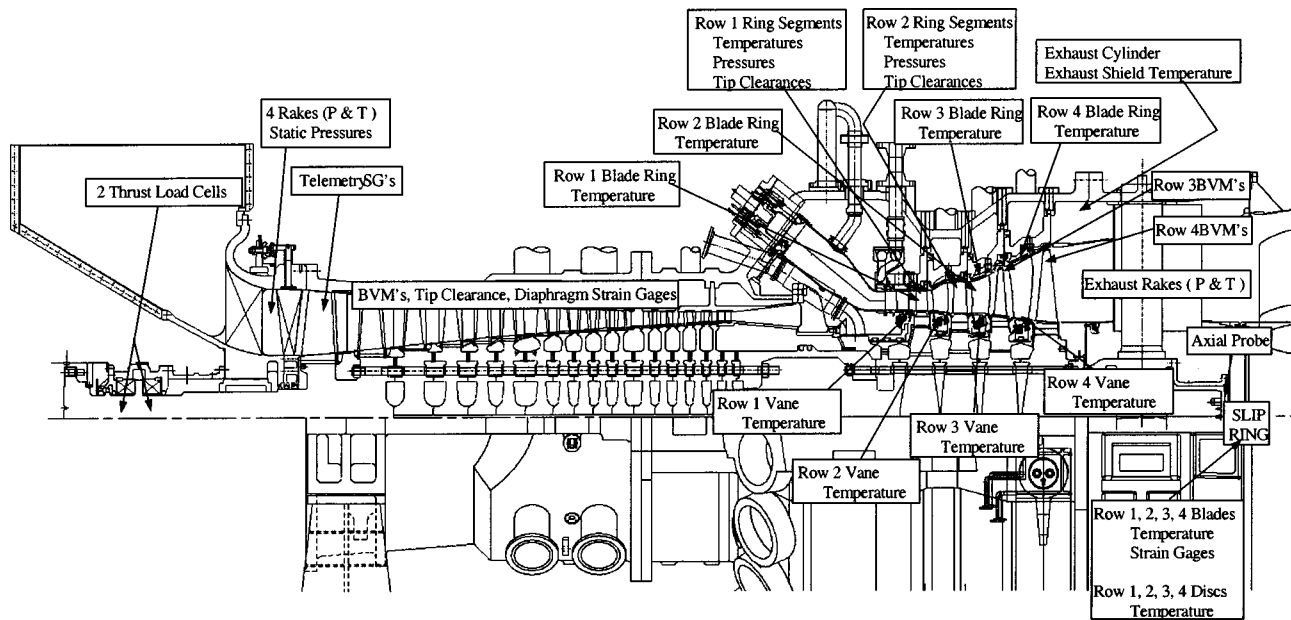

Fig. 9 W501G field test instrumentation

Technology Infusion Into Mature Frames

New technologies developed in the ATS Program were retrofitted into the whole Siemens Westinghouse gas turbine product line to improve efficiency, reduce emissions and improve mechanical integrity.

The ATS-developed compressor technology has been retrofitted into the W501F product line. Using the analytical techniques developed and proven in the ATS program, the W501F compressor was upgraded in the latest improvement to this successful frame. This advanced compressor is used on all new 501F engines. In addition, the redesigned compressor can be retrofitted to any of the 42 W501F engines that were built with the original W501F compressor. Applying this ATS technology to the W501F engine expands the benefit of the ATS program, since the W501F comprises more than 70% of future units that are sold or on order at Siemens Westinghouse.

To date, ATS-developed brush seals have been successfully incorporated and operated in W501G and W501F product lines. Pre- and post-upgrade tests have demonstrated performance improvement in retrofit applications. The ATS-developed abrasion coatings have been incorporated into W501F and W501G compressors and front turbine stages (first and second stages). The later turbine

stages (third and fourth stages) employ shrouded blades with stationary honeycomb seals, and do not require abrasion coatings.

Summary

Technology development efforts have demonstrated that ATS Program goals are achievable. Full-scale compressor tests verified the ATS compressor aerodynamic performance and mechanical integrity. Model turbine tests and internal heat transfer tests on first stage turbine vane and blade cooling designs were completed. Development of brush seals, rotor rear face seal, and abrasion coatings were completed. Development of the ultra low NO_x combustor and catalytically enhanced combustor is progressing. Several materials development programs were successfully completed. Preproduction casting development will continue on the single crystal thin wall vanes and blades. Long-term verification tests are continuing on the advanced bond coat/TBC system. W501G field verification testing was completed. New technologies developed in the ATS Program were retrofitted into the whole Siemens Westinghouse gas turbine product line. Future plans include the W501G engine evolution into the W501ATS engine by incorporating first and second-stage turbine vane closed-loop steam cooling, optimized compressor and turbine aerodynamic designs, active tip clearance control, advanced sealing, and catalytic combustion.

Acknowledgments

This research was prepared with the support of the U.S. Department of Energy, under Cooperative Agreement No. DE-FC21-95MC32267. However, any opinions, findings, conclusions, or recommendations expressed herein are those of the authors and do not necessarily reflect the views of the DOE.

References

- [1] Little, D. A., Bannister, R. L., and Wiant, B. C., 1993, "Development of Advanced Turbine Systems," *ASME Cogen Turbo Power '93 Proceedings*, IGTI, ASME, New York, 8, pp. 271-280.
- [2] Briesch, M. S., Bannister, R. L., Diakunchak, I. S., and Huber, D. J., 1994, "A Combined Cycle Designed to Achieve Greater Than 60 Percent Efficiency," *ASME J. Eng. Gas Turbines Power*, 117, pp. 734-741.
- [3] Bannister, R. L., Cheruvu, N. S., Little, D. A., and McQuiggan, G., 1995, "Development Requirements for an Advanced Turbine System," *ASME J. Eng. Gas Turbines Power*, 117, pp. 723-732.

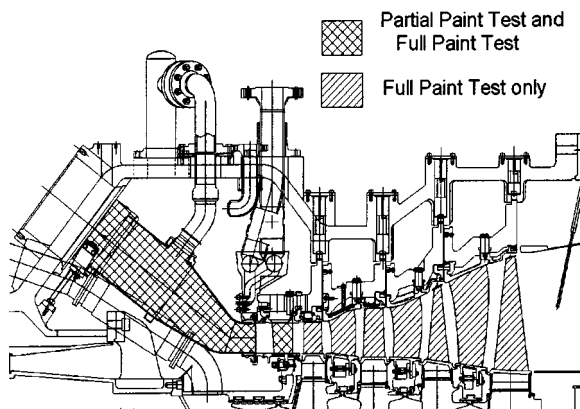

Fig. 10 W501G thermal paint test

- [4] Diakunchak, I. S., Bannister, R. L., Huber, D. J., and Roan, D. F., 1996, "Technology Development Programs for the Advanced Turbine Systems Engine," ASME Paper No. 96-GT-5.
- [5] Gaul, G., Diakunchak, I. S., and Dodd, A. M., 2001, "The W501G Testing and Validation in the Siemens Westinghouse Advanced Turbine Systems Program," ASME Paper No. 02-GT-399.
- [6] Scalzo, A. J., Bannister, R. L., DeCorso, M., and Howard, G. S., 1994, "Evolution of Westinghouse Heavy-Duty Power Generation and Industrial Combustion Turbines," ASME J. Eng. Gas Turbines Power, **118**, pp. 316–330.
- [7] Scalzo, A. J., McLaurin, L. D., Howard, G. S., Mori, Y., Hiura, H., and Sato, T., 1988, "A New 150 MW High Efficiency Heavy-Duty Combustion Turbine," ASME Paper No. 88-GT-162.
- [8] Southall, L., and McQuiggan, G., 1995, "New 200 MW Class 501G Combustion Turbine," ASME Paper No. 95-GT-215.
- [9] Wang, T., Kapat, J. S., Ryan, W. R., Diakunchak, I. S., and Bannister, R. L., 1999, "Effect of Air Extraction for Cooling and/or Gasification on Combustor Flow Uniformity," ASME J. Eng. Gas Turbines Power, **121**, pp. 46–55.