

Growth Hormone Secretagogue Increases Muscle Strength during Remobilization after Canine Hindlimb Immobilization

Richard L. Lieber, *Thomas M. Jacks, Randall L. Mohler, *Klaus Schleim, *Michelle Haven, Denise Cuizon, David H. Gershuni, Michael A. Lopez, *Donald Hora, Jr., *Ravi Nargund, *William Feeney, and *Gerard J. Hickey

*Departments of Orthopaedics and Bioengineering, Biomedical Sciences Graduate Group, University of California and Veterans Administration Medical Centers, San Diego, California, and *Merck Research Laboratories (MRL), Rahway, New Jersey, U.S.A.*

Summary: Twenty-two beagles were divided into two equal groups, and the right hindlimb of each animal was immobilized at 105° of knee flexion by external fixation. After 10 weeks of fixation, the device was removed, allowing free mobility for the following 5 weeks. Each day throughout the 15 weeks, one group received a growth hormone secretagogue (treatment) at a dose of 5 mg/kg, and the other received a lactose placebo (control). At weeks 0, 10, and 15, strength as indicated by maximum isometric extension torque was measured in the right hindlimb, biopsies of the vastus lateralis muscle were taken, and the dogs were weighed. Weekly blood samples were analyzed for insulin-like growth factor-1, blood urea nitrogen, and creatine phosphokinase. Between weeks 0 and 10, tetanic torque declined by about 60% ($p < 0.001$) in both groups, with no significant difference between the groups ($p > 0.7$). Between weeks 10 and 15, tetanic torque in the treated group increased by 0.81 Nm; this was significantly greater than the increase of 0.25 Nm in the placebo group ($p < 0.05$). The diameters of slow (type-1) and fast (type-2) fibers measured from the vastus lateralis muscle followed the same trend. At all time points, fiber diameter correlated strongly with torque; this argues against nonmuscular causes such as nerve injury for strength loss. The mean levels of insulin-like growth factor-1 increased 100% by week 4 in the treated group and remained elevated by about 60% throughout the experiment. Levels of insulin-like growth factor-1 in the placebo group decreased 30% within week 1 and remained depressed throughout the experiment. Our interpretation of these data suggests that the growth hormone secretagogue elevated levels of serum insulin-like growth factor-1, which in turn increased the size and strength of the quadriceps muscle during remobilization. These data may ultimately have therapeutic application to humans during rehabilitation after prolonged inactivity.

The strengthening of skeletal muscle after surgery or prolonged disuse remains a primary goal of rehabilitation. Many approaches — including electrical stimulation (10), voluntary exercise (15), continuous passive motion (7), and hormone therapy (32) — have been used to strengthen atrophied muscles. In some cases, treatment modalities are limited by a patient's access to rehabilitation professionals or rehabilitation devices. Medical treatment of muscle atrophy with hormone therapy offers the advantage of requiring relatively little effort on the part of the patient to achieve the desired therapeutic result.

There is ample evidence of hypertrophy of skeletal muscle in response to anabolic steroids. For example,

strong correlations were demonstrated between muscle strength and serum testosterone concentration in elderly men in whom a marked loss of muscle function was correlated with low testosterone levels relative to stronger age-matched controls (1). In related studies, the administration of testosterone to elderly men (to increase serum testosterone to a range observed in younger men) increased lean body mass (32) and grip strength (25). The effect of this hormone may be mediated, at least in part, by serum insulin-like growth factor-1 (IGF-1) (4). The anabolic effects on humans of IGF-1 administration have been well documented. For example, recombinant IGF-1 attenuated the catabolic effects of glucocorticoids (23) and increased muscle protein synthesis in young men (9). Similar results were obtained *in vitro* with other muscle growth factors such as fibroblast growth factor (FGF). At the cellular level, skeletal muscle myotubes grown in culture in the presence of FGF demonstrated a marked increase in protein synthesis. This effect was enhanced

Received November 25, 1996; accepted June 18, 1997.

Address correspondence and reprint requests to R. L. Lieber at Department of Orthopaedics (9151), U.C. San Diego School of Medicine and V.A. Medical Centers, 3350 La Jolla Village Drive, San Diego, CA 92161, U.S.A. E-mail: rlieber@ucsd.edu

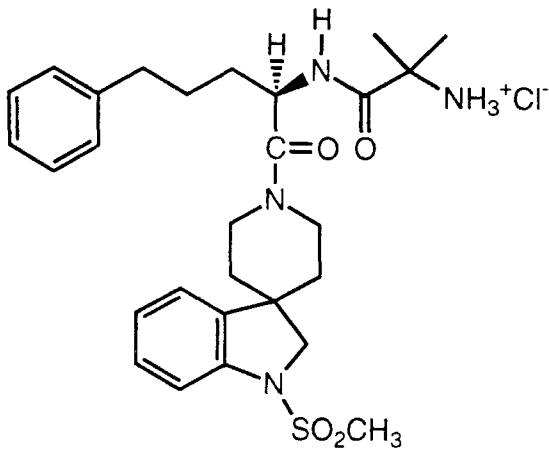

FIG. 1. The chemical structure of compound L163,255, a growth hormone secretagogue.

when the cultured cells were mechanically loaded, whereas it was lessened when the availability of growth factor was attenuated by adding specific binding proteins (5). Thus, both *in vitro* model systems and human clinical studies provide evidence that hormone therapy increases muscle mass by directly activating protein synthesis, which causes hypertrophy of muscle fiber. Hormone therapy may therefore represent an adjuvant method for preventing muscle atrophy or facilitating muscle recovery from muscle atrophy in a human patient population.

MK-0677 is a novel, orally active growth hormone secretagogue that, in beagles, induces an immediate and long-lasting increase in levels of serum growth hormone after a single intravenous or oral dose (12,27). This compound caused serum growth hor-

mone levels to be elevated for as long as 360 minutes after oral dosing, compared with only 75-90 minutes for the benzolactam and growth hormone-releasing peptide secretagogues (11,13). IGF-1 levels were increased 30% at 480 minutes after oral dosing with MK-0677. After repeated oral dosing in dogs at 1 mg/kg, IGF-1 levels increased 122 and 124% on days 7 and 14, respectively (12,14).

In this study, L-163,255, a spiro-piperidine growth hormone secretagogue (Fig. 1) and a close structural analog of MK-0677, was administered to a mature female beagle population undergoing muscle atrophy secondary to immobilization by external fixation. Our hypothesis was that the treated group would experience less atrophy and loss of muscle strength than controls matched for age and sex.

METHODS

Experimental Subjects

Twenty-two intact, mature female beagles (4-8 years of age), weighing 9.5-15.4 kg, were paired according to weight. The pairs were randomly divided to form two groups of 11 animals each. All procedures were conducted in accordance with the National Institutes of Health Guide for the Care and Use of Animals and the University of California, San Diego and Merck Research Laboratories Committees' Guidelines on the Use of Animal Subjects in Research. One group of dogs received L-163,255, at a dose of 5 mg/kg, as a solution (2 ml water/kg body mass) by gavage once per day. The control group received a lactose placebo (5 mg/kg) as a solution (2 ml water/kg body mass).

Limb Immobilization

The right hindlimb of each dog was maintained in a nonweight-bearing position for 10 weeks by a transarticular bilateral external skeletal fixator that immobilized the right knee joint at approxi-

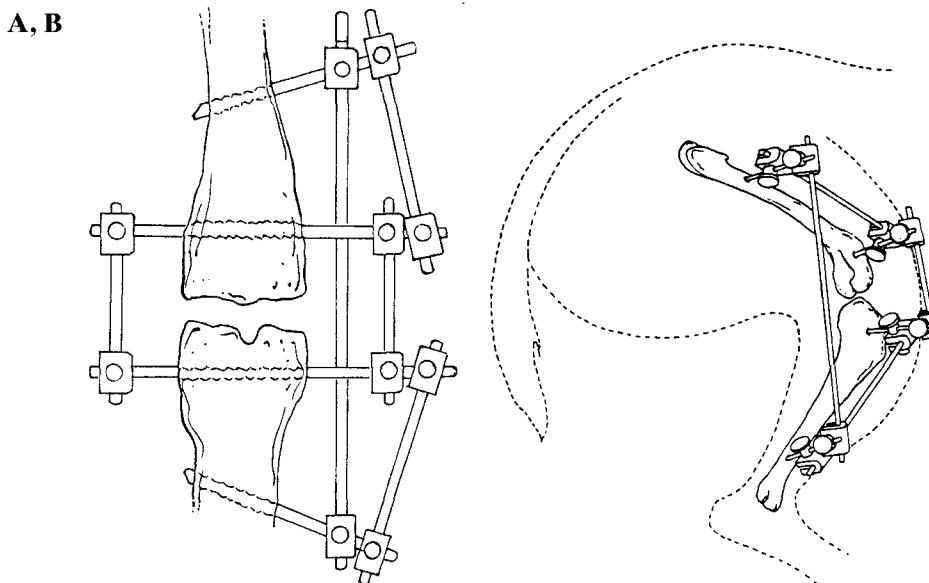

FIG. 2. A: Diagram depicting the placement of the transarticular bilateral external skeletal fixator on the right hindlimb. Interface cortical half-pins inserted in the diaphysis of the femur and tibia were connected to one another laterally to place the stifle in 105° of flexion. Full centerface cancellous pins in the distal femur and proximal tibia were connected medially and laterally to one another and laterally to the proximal and distal half-pins. **B:** Depiction of the apparatus, placed on the beagle hindlimb, that was designed to maintain the angle of the knee joint at about 105° of flexion.

A, B

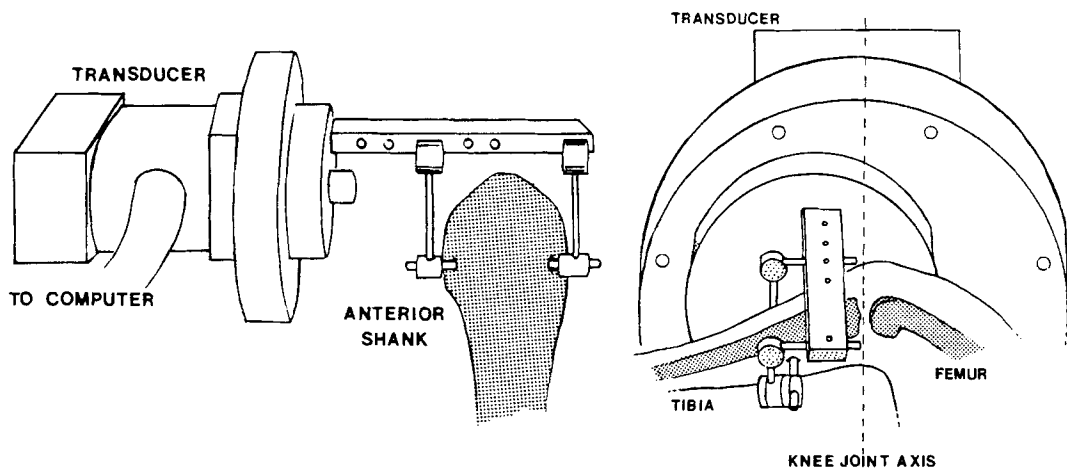

FIG. 3. The apparatus used to measure knee extension torque. The measuring axis of the torque transducer is aligned with the rotating axis of the knee, permitting true torque transduction. The device is clamped to the pins used by the external fixator.

mately 105° of flexion (Fig. 2). Prior to surgery, the dogs were given acepromazine (0.07 mg/kg) and atropine (0.022 mg/kg) intramuscularly. Anesthesia was induced with methohexital administered intravenously to effect (8.8-13.2 mg/kg) and maintained with isoflurane in oxygen. Immediately after surgery, buprenorphine (0.02 mg/kg) was administered intramuscularly for analgesia. The dogs were examined twice daily throughout the 10-week immobilization period, and the sites of pin entry were cleaned as needed. No pin track infections were observed throughout this period. After removal of the external fixators, the dogs were allowed free mobility within the 1 × 2 m pens for an additional 5 weeks and were walked outside of the cage for a few minutes during cage maintenance operations. The transarticular bone pins were replaced at week 15 for the final tetanic torque testing.

Serum Analyses

Blood samples were collected from the jugular vein at weekly intervals, and serum was harvested and stored at -20°C for determination of IGF-1, blood urea nitrogen, and creatine phosphokinase. The assays were performed at the Veterinary Diagnostic and Clinical Pathology Laboratories, Cornell University, Ithaca, NY, U.S.A. Each assay had been previously validated for dog serum. The levels of blood urea nitrogen and creatine phosphokinase were determined on an Autoanalyzer (model 911; Boehringer-Mannheim, St. Louis, MO, U.S.A.), and IGF-1 levels were measured by radioimmunoassay. For IGF-1, the sensitivity, intra-assay, and interassay coefficients of variation were 0.06 ng/ml, 5%, and 10%, respectively.

Knee Extension Torque Testing

At 0, 10, and 15 weeks, maximum tetanic knee extension torque was measured with a specially designed jig that was secured to the fixator pins after the fixator connecting bars were removed. The dogs were anesthetized throughout the muscle-testing session, which lasted approximately 1 hour. During this testing period, body temperature was monitored with a rectal probe and maintained within a normal range with use of a heating pad. Investigators conducting these tests were blinded with regard to treatment groups.

The torque-measuring device was designed so that extension torque was transduced directly by a six-degrees-of-freedom load cell (JW³ Transducers, Woodland, CA, U.S.A.) aligned with the knee axis of rotation. This alignment was accomplished with the use of an adjustable plate having a displaceable rotation axis that was aligned with the knee joint of each dog at the time of surgery (Fig. 3). Alignment was determined by translating the transducer during rotation of the knee joint such that the transducer self-aligned with the axis of rotation of the knee joint. The angular stiffness of the

device, including pins, was 1-2 Nm/°; this permitted 5-10° of joint rotation during maximal quadriceps activation. Repeated measurements of maximum knee extension torque on two animals in pilot experiments that lasted over 3 weeks (torque was measured twice per week) yielded a root-mean-squared variation of only 0.73 Nm, corresponding to a relative variability of about 12%.

Supramaximal activation of the quadriceps muscle was accomplished by direct stimulation of the surgically isolated femoral nerve. The femoral nerve was exposed in the groin area, and maximum tetanic activation of the quadriceps was elicited with the use of a stimulation paradigm consisting of approximately 30 mA of current delivered at 100 Hz for 2 seconds (Fig. 4). The nerves were protected from drying by replacing the natural skin flap created by the procedure after the cuff was placed on the nerve. The measured fluctuation in torque was extremely small (nominally 0.05 Nm root-mean-square), indicating sufficient stiffness in the measuring device to prevent muscle shortening or limb movement. Preliminary studies of the frequency-force and current-force relationships demonstrated that this stimulation paradigm consistently represented a supramaximal level, and thus it was used for all testing sessions. Two-minute rest periods were interposed between contractions, which were taken in repeated fashion to avoid

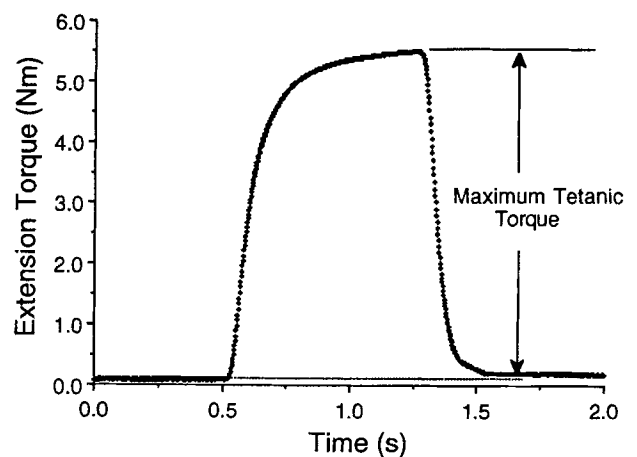

FIG. 4. Sample record from the torque transducer. Stimulation occurred from 0.5 to 1.5 seconds at 100 Hz and 30 mA. Torque reaches its peak by about 1 second. The peak torque is measured from the maximum torque value to the baseline value of the pre-stimulation torque record (dotted line).

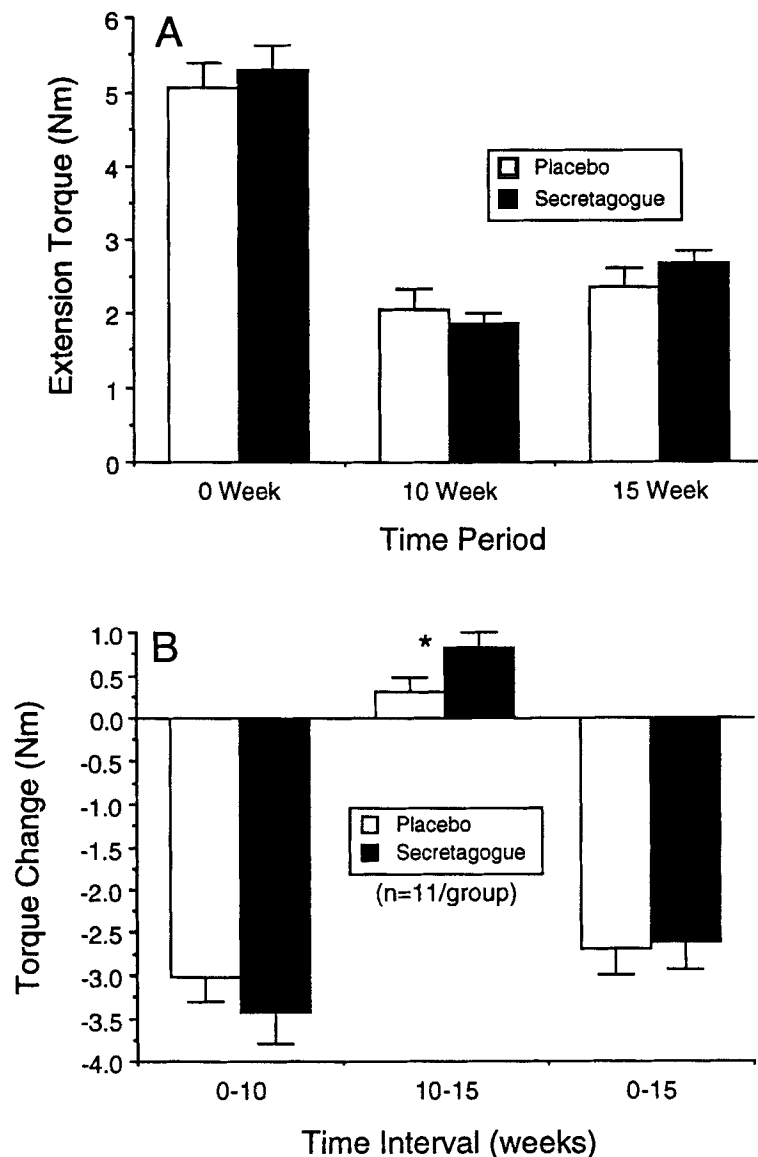

FIG. 5. Torque measured over the experimental intervals studied. Bars show mean \pm SEM for the secretagogue group ($n = 10$, filled bars) and the control group ($n = 11$, open bars). The only significant difference between groups occurred during the remobilization period from 10 to 15 weeks (asterisk). **A:** Absolute torque change. **B:** Torque change relative to the initial value in time interval.

the complications of fatigue. Pilot experiments demonstrated no change in maximum tetanic torque for as long as even 1 hour of stimulation when repeated stimuli spaced at 90-second intervals were used. After the nerve was isolated and the torque jig was set up, the nominal time required to perform contractile tests on the animals was 10 minutes. Contractile data were acquired on a Macintosh IIfx computer running the Superscope program (GW Instruments, Watertown, MA, U.S.A.). The data were acquired at 500 Hz and stored on a disk for subsequent analysis. At the conclusion of contractile testing, the exposed femoral nerve was wrapped in a sterile silicone sheath to prevent the proliferation of connective tissue in the region of the tested nerve, the exposed area was closed in layers, and a subcuticular skin suture was performed. Care was taken not to constrict the nerve in any way, and no signs of ischemic or mechanical injury were seen in any nerves examined 10 and 15 weeks later.

Muscle Biopsies and Immunohistochemistry

At 0, 10, and 15 weeks, open biopsies were taken from the vastus

lateralis muscle through the same incision and in the same general area. The muscle biopsy was isolated and secured to wooden sticks with suture material at resting length. The muscle tissue proximal and distal to the sutures was cut with iris scissors, leaving the biopsy on the wooden stick at resting length. The biopsy was then frozen in isopentane cooled by liquid nitrogen (-159°C) and stored at -80°C for subsequent analysis.

Cross sections ($8\ \mu\text{m}$) of frozen muscle were stained with hematoxylin and eosin for routine examination of fiber packing and extracellular matrix material and for determination of oxidative activity with use of the succinate dehydrogenase reaction (26). Serial sections were labeled with commercially obtained antibodies (Novocastro Laboratories, distributed by Vector Laboratories, Burlingame, CA, U.S.A.) against fast and slow myosin heavy chains to distinguish between fast and slow fiber types, respectively. The fibers were classified as either type 1 (slow) or type 2 (fast) depending on their reactivity with the myosin heavy chain antibodies (28). Serial sections were also stained with the laminin antibody clone 2E8 (Gibco, Gaithersburg, MD, U.S.A.) to identify the fiber outline. This

outline was recognized by a threshold algorithm on an imaging system consisting of an IBM 486 microcomputer (Image 1, West Chester, PA, U.S.A.) for data acquisition. After semiautomated outlining of the muscle fibers, final editing to define individual fiber outlines was conducted manually. Fiber area and minor diameter of the elliptical shape were then quantified. Some muscles were sectioned at oblique angles; therefore, the minor fiber diameter was used to quantify fiber size. This value is known to be insensitive to the sectioning angle (33). The number of fibers to be sampled (n) within each biopsy was calculated with use of the equation:

$$n = \frac{\sigma^2 \cdot \left[\frac{Z_{\alpha}}{2} \right]^2}{\delta^2}$$

where σ is the SD of the sample, δ is the desired confidence interval, and α is the confidence level. In pilot experiments measuring the diameter of muscle fibers in both normal and immobilized tissues, we obtained SDs of $5.4 \mu\text{m}^2$, used a confidence interval of 95% ($Z = 1.96$), and attempted to be within $2.5 \mu\text{m}$ ($\delta = 2.5$) of the true fiber diameter. Thus, to have a 95% chance of being within $2.5 \mu\text{m}$, it was necessary to sample at least 20 fibers per field. Our final sampling protocol consisted of measurement in three regions per section and 25 fibers per region in order to provide an adequate representation.

TABLE 1. *Vastus lateralis* muscle fiber diameter (μm)

	Fast (type-2) fibers		Slow (type-1) fibers	
	Secretagogue	Control	Secretagogue	Control
0 weeks	28.6 \pm 1.0	28.7 \pm 1.6	31.3 \pm 2.0	29.3 \pm 1.6
10 weeks	13.1 \pm 1.3	12.2 \pm 1.0	21.8 \pm 1.4	19.1 \pm 1.1
15 weeks	19.8 \pm 1.8	16.3 \pm 1.3	20.6 \pm 2.1	21.2 \pm 1.3

Statistical Analyses

The various parameters measured as a function of time were compared between groups with the use of a 2×3 two-way analysis of variance (ANOVA) with repeated measures (the experimental group as the grouping factor and time as the repeated measure). In addition, to allow for the examination of change relative to the initial values, parameters of change were calculated relative to these values and changes were compared for the 0-10, 10-15, and 0-15 week intervals by one-way ANOVA. Trapezoidal areas under the IGF-1 response curve for different time periods were calculated for each animal and were compared between

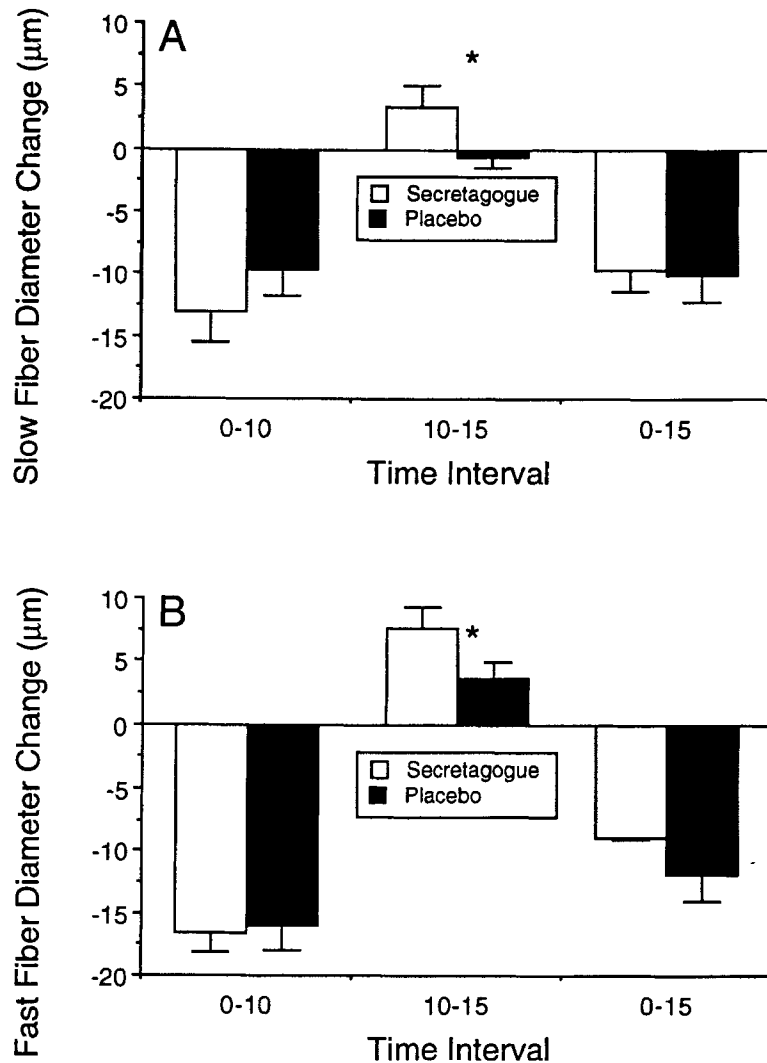

FIG. 6. Change in fiber size measured over the experimental intervals studied. Bars show mean \pm SEM. The only significant difference between groups was during the remobilization period from 10 to 15 weeks (asterisk). **A:** Type-1 (slow) fibers. **B:** Type-2 (fast) fibers. Absolute fiber sizes corresponding to these changes in diameter are provided in Table 1.

groups for the three time periods by one-way ANOVA. Linear regression was used to investigate correlations between fiber size and extension torque. For all parametric statistics, data sets were first screened for normality to justify the assumptions of the parametric tests (Statview 4.5; Abacus Concepts, Berkeley, CA, U.S.A.). For the change scores and the IGF-1 trapezoidal areas, the high degree of kurtosis required the use of arcsine and natural log transformations, respectively, to restore normality to the data set (29).

To assess the effects of treatment on weight gain from week 0 to week 10, first the two observations (weight at weeks 0 and 10) on the same animal were paired together to reduce the variation due to animals, and then the weight gain of each animal was calculated as the difference between the paired data. The paired *t* test was used to test the significance of the effects of treatment on weight gain. Similarly, the significance of the effects of treatment on weight gain at week 15 in comparison with weeks 0 and 10 was also tested by the paired *t* test.

IGF-1 levels at week 0 were compared by the two-sample *t* test to verify that the animals in the two groups were not significantly different prior to treatment. Trapezoidal areas under the IGF-1 response curve over different lengths of time were calculated for each animal. ANOVA techniques were used to assess the significance of the effects of treatment on area under curve between week 0 and week 15. The data were transformed to the natural logarithm scale to better meet the normality and homogeneity of variance assumptions required by the ANOVA techniques. In all cases, the critical type-I error rate was set to 5% (i.e., $\alpha = 0.05$) and statistical power was approximately 50%. All data are presented as mean \pm SEM unless otherwise stated.

RESULTS

One treated dog was removed from the study due to a tibial fracture sustained during week 1. At the beginning of the study, the mean body weights of the

treated ($n = 10$) and placebo ($n = 11$) groups were 12.3 ± 0.5 and 11.9 ± 0.4 kg, respectively. Two-way ANOVA revealed a significant effect of time ($p < 0.05$) but no significant difference between groups and no significant interaction. Over the 15 weeks, the mean weight loss in the treated group was only 0.21 ± 0.20 kg compared with 1.13 ± 0.19 kg in the placebo group ($p < 0.005$). In the first week, levels of creatine phosphokinase increased, probably due to the disruption of muscle cell membranes during surgery (35), whereas levels of blood urea nitrogen decreased, probably due to the reduced intake of food observed. However, each of these parameters returned to baseline levels over the course of the study, with no differences between the two groups.

Between 0 and 10 weeks, maximum tetanic torque declined by more than 50% in both groups: from 4.91 ± 1.12 to 1.95 ± 0.93 Nm in the placebo group and from 5.30 ± 1.05 to 1.87 ± 0.44 Nm in the treated group (Fig. 5). However, between weeks 10 and 15, tetanic torque increased significantly more in the treated group (0.82 ± 0.17 Nm or 43% of the value at 10 weeks) than in the placebo group (0.31 ± 0.14 Nm or 16% of the value at 10 weeks) ($p < 0.05$). Two-way ANOVA revealed a significant effect of time ($p < 0.0001$) but no significant difference between groups ($p > 0.5$) and no significant interaction ($p > 0.5$).

Paralleling the change in torque, there was no significant difference between the groups in the magnitude of the decrease of diameter of type-1 or type-2

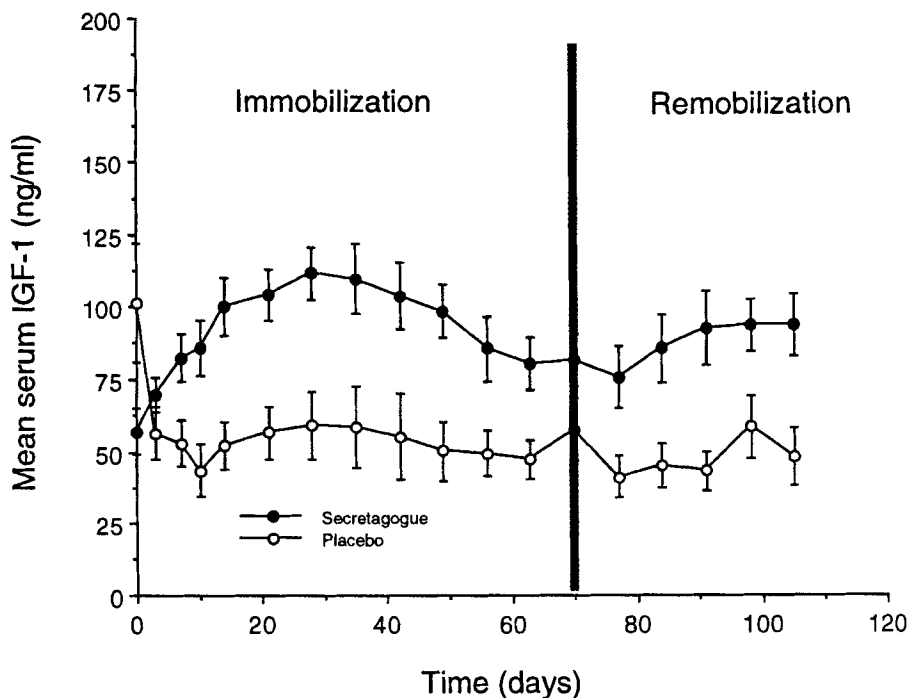

FIG. 7. Serum insulin-like growth factor-1 (IGF-1) levels recorded at weekly intervals throughout the experimental period. Data represent mean \pm SEM for each time period and demonstrate a significant difference between groups on the basis of area under curve as a function of time ($p < 0.01$).

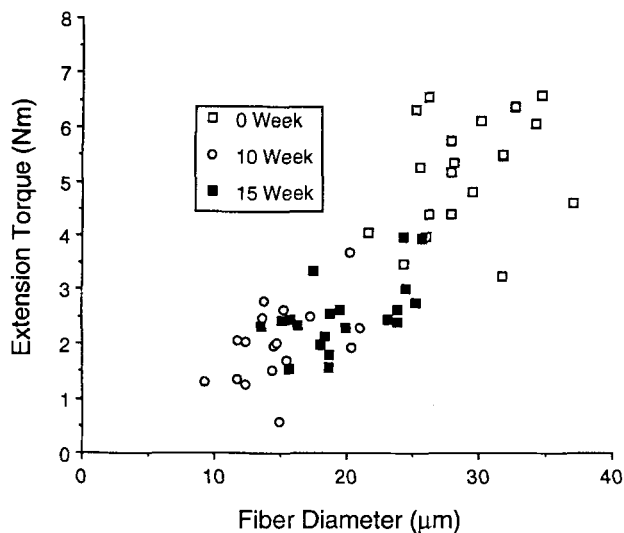

FIG. 8. The relationship between average fiber size and knee extension torque across groups for the three experimental time periods examined. Note the strong correlation between the two parameters. Data for both experimental groups are pooled at each of three time points. Linear regression revealed a highly significant relationship between fiber size and knee extension torque ($p < 0.001$, $r^2 = 0.688$), given by the following equation: torque (Nm) = fiber size (μm) * 0.198 (Nm/ μm) - 0.977. The y intercept is nonzero due to preloading of the torque transducer by the shank.

fiber in the vastus lateralis muscle between weeks 0 and 10. The diameter of type-1 fiber decreased by about 35% in both groups ($-13 \mu\text{m}$ in the treated group and $-10 \mu\text{m}$ in the control group), whereas that of type-2 fiber decreased by about 50% ($-16 \mu\text{m}$ in both groups) (Fig. 6). Between 10 and 15 weeks, as with the functional torque measurements, a significantly greater muscle response to remobilization was seen in the treated group. The diameter of type-1 fibers increased significantly more in the treated group (32%; $+3.4 \mu\text{m}$) than in the placebo group (2% decrease; $-0.6 \mu\text{m}$) ($p < 0.05$). Similarly, the diameter of type-2 fiber increased by 68% ($+7.6 \mu\text{m}$) in the treated group but only by 32% ($+3.6 \mu\text{m}$) in the placebo group; the difference between these diameters was nearly statistically significant ($p = 0.078$). As with the functional parameters, two-way ANOVA revealed a significant effect of time ($p < 0.0001$) but no significant difference between groups ($p > 0.3$) and no significant interaction ($p > 0.1$).

Serum IGF-1 levels were slightly higher ($p = 0.09$) in the placebo group at the beginning of the study (Fig. 7). In spite of this initial difference, mean IGF-1 levels in the treated group increased by 100% by week 4 and remained elevated by about 60% throughout the experimental period. IGF-1 levels in the placebo group decreased by 30% within the first week and remained depressed throughout the experimental period. The difference in IGF-1 levels over time between groups, on the basis of area under curve, was highly significant ($p < 0.01$).

To determine whether changes in the size of muscle fiber were causally related to the change in torque, we examined the correlation between the two variables. Other factors could alter torque, including damage to nerve or muscle fiber and changes in muscle fiber length that would shift the joint angle at which optimal force was generated. Our analysis demonstrated a strong correlation between fiber diameter and torque across all time periods and experimental groups, suggesting a causal relation between the two parameters (Fig. 8) ($p < 0.001$). The equation describing this result is torque (Nm) = fiber size (μm) * 0.198 (Nm/ μm) - 0.977 ($p < 0.001$, $r^2 = 0.688$).

DISCUSSION

The purpose of this study was to determine whether the administration of a growth hormone secretagogue could prevent muscle atrophy or facilitate recovery from atrophy due to external fixation, or both. We found that the compound had no effect on either muscle strength or muscle fiber size during immobilization but that a significant enhancement of the size and strength of fiber occurred during the remobilization period.

In retrospect, it may not be surprising that the increased IGF-1 levels had no effect in preventing muscle atrophy but did facilitate recovery from the atrophic condition. There is ample evidence in the basic science literature that the anabolic effects of growth factors are dependent on mechanical stimulation of the muscle tissue. A clear example of such a requirement is seen in *in vitro* studies in which exogenous FGF was added to a myoblast cell culture system (5). Although the addition of the growth factor alone resulted in a modest (10%) upregulation of protein synthesis in the native culture, when the addition of the growth factor was combined with mechanical stimulation, the rates of protein synthesis doubled. This effect was apparently mediated by the small disruptions of the plasma membrane known to release growth factors that can then act in an autocrine fashion (24). Thus, it is likely that the growth hormone secretagogue would have had a larger effect during remobilization if the dogs had been explicitly exercised or even if they had received functional electrical stimulation therapy. In the current study, the dogs were permitted cage activity and a short daily walk during remobilization, but no attempt was made to provide any type of exercise designed to rehabilitate the immobilized limb.

Numerous experimental studies have documented the time course and nature of muscle atrophy that occurs secondary to immobilization (2,3,6,8,19,30), but, to our knowledge, this study is the first to quantify muscle strength and muscle fiber size in the same experimental system. The significance of this com-

bined structural and functional approach is that the potential causal relationship between the two factors can be defined. It is significant that a strong correlation between size of muscle fiber and joint torque was obtained (Fig. 8). This is the inevitable result if atrophy of muscle fiber is actually the cause of the reduced joint torque. (Note that the torque graph does not pass through 0, because there is a resting negative torque on the transducer device due to the moment produced by the mass of the shank.) Other muscular changes could alter joint torque but would be independent of the size of muscle fiber because the joint moment measured results from the interaction between muscle force and knee extension moment arm and not from either factor in isolation. We demonstrated, in frog hindlimbs (16-18,22) and human upper extremities (20,21), that the joint angle at which the maximum moment occurs is neither the angle at which maximum muscle force occurs nor the angle at which maximum moment arm occurs but is a result of the interaction between the two. We are not confident that the angle of 105°C used to test the knee joint corresponded to optimal muscle length. In fact, on the basis of pilot data demonstrating increased torque at lesser angles of flexion (where the moment arm is presumably smaller), this is probably not the case. As a result, any factor that changed optimal muscle length would change the extension moment independent of maximal muscle force and muscle fiber size. In the immobilization model, the most likely muscular change (other than the fiber atrophy reported here) is the change in the serial sarcomere number. This number is highly plastic and changes dramatically in skeletal muscle after immobilization (31,35). Other potential confounding factors could include increased patellar tendon compliance, which would shift optimal muscle length (36), or connective tissue proliferation. The fact that the correlation between fiber area and torque was so strong does not rule out these other possibilities but suggests that their relative influence would be small. The regression coefficients for both slope ($p < 0.0001$) and intercept ($p < 0.05$) were highly significant. Although the nonzero slope was expected, the large nonzero intercept (-0.977) was surprising because one would expect a muscle with a fiber diameter of zero to produce zero torque. The explanation for the nonzero intercept was that the shank itself loaded the torque transducer device in the flexion direction with a preload of about 1 Nm.

Although the levels of growth hormone were not measured in this study, it is reasonable to assume that the increases were of the same magnitude as those measured in previous studies. The fact that IGF-1 levels were not increased more than 100% was probably due to the downregulation of the growth hormone response as described above because IGF-1

levels can be increased 150% or more by directly administering growth hormone to healthy beagles (12). The trauma due to the surgery and subsequent immobilization of one limb, which apparently was the cause of a 30% decrease in IGF-1 levels in dogs treated with a placebo, may also have prevented a further increase in IGF-1 levels. It is possible, therefore, that the strength and cross-sectional increases were delayed in this group rather than enhanced in the experimental group.

In summary, our interpretation of these data is that administration of the growth hormone secretagogue increased serum IGF-1 levels such that muscle fiber protein synthesis associated with the remobilization period was enhanced, resulting in increased fiber size and muscle strength. These findings suggest that growth hormone secretagogues may ultimately have therapeutic application to humans during rehabilitation after prolonged inactivity if their use is coupled with remobilization.

Acknowledgment: We thank Jennie Massie (U.C. San Diego) for helpful advice regarding canine surgical treatment and postoperative care. We also thank Brian Chen, Jennifer Kim, and Sheryl Kramer for helpful technical assistance and Rebecca Chamberlain for skilled artistic rendition of the experimental apparatus. Also, we acknowledge the Laboratory Animal Resources staff at Merck (Paul Cunningham, Bonnie Friscino, Liza Gantert, and Chris Livingston) for surgical assistance and Dr. Simon Roe (North Carolina State University, College of Veterinary Medicine) for assistance in the design of the external skeletal fixator. Finally, we thank Bruce Mrosko and Dr. Mark Gomez for assistance in designing the experimental apparatus and Dongui Zhang for statistical analysis.

REFERENCES

1. Abbasi AA, Drinka PJ, Mattson DE, Rudman D: Low circulating levels of insulin-like growth factors and testosterone in chronically institutionalized elderly men. *J Am Geriatr Soc* 41:975-982, 1993
2. Booth FW, Kelso JR: Effect of hind-limb immobilization on contractile and histochemical properties of skeletal muscle. *Pfluegers Arch* 342:123-238, 1973
3. Booth FW, Seider MJ: Recovery of skeletal muscle after 3 mo of hindlimb immobilization in rats. *J Appl Physiol* 47:435-439, 1979
4. Borski RJ, Tsai W, DeMott-Friberg R, Barkan AL: Regulation of somatic growth and the somatotrophic axis by gonadal steroids: primary effect on insulin-like growth factor I gene expression and secretion. *Endocrinology* 137:3253-3259, 1996
5. Clarke MSF, Feeback DL: Mechanical load induces sarcoplasmic wounding and FGF release in differentiated human skeletal muscle cultures. *FASEB J* 10:502-509, 1996
6. Edgerton VR, Barnard RJ, Peter JB, Maier A, Simpson DR: Properties of immobilized hind-limb muscles of the Galago senegalensis. *Exp Neurol* 46:115-131, 1975
7. Feehan LM, Beauchene JG: Early tensile properties of healing chicken flexor tendons: early controlled passive motion versus postoperative immobilization. *J Hand Surg [Am]* 15:63-68, 1990
8. Fournier M, Roy RR, Perham H, Simard CP, Edgerton VR: Is limb immobilization a model of muscle disuse? *Exp Neurol* 80:147-156, 1983
9. Fryburg DA: Insulin-like growth factor I exerts growth hormone- and insulin-like actions on human muscle protein metabolism. *Am J Physiol* 267:E331-E336, 1994
10. Gould N, Donnermeyer D, Pope M, Ashikaga T: Transcutane-

- ous muscle stimulation as a method to retard disuse atrophy. *Clin Orthop* 164:215-220, 1982
11. Hickey G, Jacks T, Judith F, Taylor J, Schoen WR, Krupa D, Cunningham P, Clark J, Smith RG: Efficacy and specificity of L-692,429, a novel nonpeptidyl growth hormone secretagogue, in beagles. *Endocrinology* 134:695-701, 1994
 12. Hickey G, Jacks TM, Schleim K-D, Frazier E, Chen H, Krupa D, Feeney W, Nargund R, Patchett A, Smith RG: Repeat administration of growth hormone secretagogue MK-0677 increases and maintains elevated IGF-1 levels in beagles. *J Endocrinol* 152:183-192, 1997
 13. Jacks T, Hickey G, Judith F, Taylor J, Chen H, Krupa D, Feeney W, Schoen W, Ok D, Fisher MH, Wyratt MJ, Smith RG: Effects of acute and repeated intravenous administration of L-692,585, a novel non-peptidyl growth hormone secretagogue, on plasma growth hormone, IGF-1, ACTH, cortisol, prolactin, insulin, and thyroxine levels in beagles. *J Endocrinol* 143:399-406, 1994
 14. Jacks T, Smith R, Judith F, Schleim K, Frazier E, Chen H, Krupa D, Hora D Jr, Nargund R, Patchett A, Hickey G: MK-0677, a potent, novel, orally active growth hormone (GH) secretagogue: GH, insulin-like growth factor I, and hormonal responses in beagles. *Endocrinology* 137:5284-5289, 1996
 15. Laughman RK, Youdas JW, Garrett TR, Chao EYS: Strength changes in the normal quadriceps femoris muscle as a result of electrical stimulation. *Phys Ther* 63:494-499, 1983
 16. Lieber RL, Baskin RJ: Direct memory access of diffraction patterns from striated muscle: a software view. *Comp Prog Biomed* 13:27-31, 1981
 17. Lieber RL, Boakes JL: Sarcomere length and joint kinematics during torque production in frog hindlimb. *Am J Physiol* 254:C759-C768, 1988
 18. Lieber RL, Boakes JL: Muscle force and moment arm contributions to torque production in frog hindlimb. *Am J Physiol* 254:C769-C772, 1988
 19. Lieber RL, McKee-Woodburn T, Gershuni DH: Recovery of the dog quadriceps after 10 weeks of immobilization followed by 4 weeks of remobilization. *J Orthop Res* 7:408-412, 1989
 20. Lieber RL, Loren GJ, Fridén J: In vivo measurement of human wrist extensor muscle sarcomere length changes. *J Neurophysiol* 71:874-881, 1994
 21. Loren GJ, Shoemaker SD, Burkholder TJ, Jacobson MD, Fridén J, Lieber RL: Influences of human wrist motor design on joint torque. *J Biomech* 29:331-342, 1996
 22. Mai MT, Lieber RL: A model of semitendinosus muscle sarcomere length, knee and hip joint interaction in the frog hindlimb. *J Biomech* 23:271-279, 1990
 23. Mauras N, Beaufreere B: Recombinant human insulin-like growth factor-I enhances whole body protein anabolism and significantly diminishes the protein catabolic effects of prednisone in humans without a diabetogenic effect. *J Clin Endocrinol Metab* 80:869-874, 1995
 24. McNeil PL, Khakee R: Disruptions of muscle fiber plasma membranes: role in exercise-induced damage. *Am J Pathol* 140:1097-1109, 1992
 25. Morley JE, Perry HM III, Kaiser FE, Kraenzle D, Jensen J, Houston K, Mattammal M, Perry HM Jr: Effects of testosterone replacement therapy in old hypogonadal males: a preliminary study. *J Am Geriatr Soc* 41:149-152, 1993
 26. Nachlas MM, Tsou KC, de SE, Cheng CS, Seligman AM: Cytochemical demonstration of succinic dehydrogenase by the use of a new p-nitrophenyl substituted ditetrazole. *J Histochem Cytochem insert*:420-436, 1957
 27. Patchett AA, Nargund RP, Tata JR, Chen M-H, Barakat KJ, Johnston DBR, Cheng K, Chan WW-S, Butler B, Hickey G, Jacks T, Schleim K, Pong S-S, Chaung L-YP, Chen HY, Frazier E, Leung KH, Chiu S-HL, Smith RG: Design and biological activities of L-163,191 (MK-0677): a potent, orally active growth hormone secretagogue. *Proc Natl Acad Sci U S A* 92:7001-7005, 1995
 28. Pearse AGE: *Histochemistry: Theoretical and Applied*, 2nd ed. Boston, Little, Brown, 1961
 29. Sokal RR, Rohlf FJ: *Biometry*, 2nd ed. San Francisco, Freeman, 1981
 30. Tabary JC, Tabary C, Tardieu C, Tardieu G, Goldspink G: Physiological and structural changes in the cat's soleus muscle due to immobilization at different lengths by plaster casts. *J Physiol (Lond)* 224:231-244, 1972
 31. Tabary JC, Tardieu C, Tardieu G, Tabary C, Gagnard L: Functional adaptation of sarcomere number of normal cat muscle. *J Physiol (Paris)* 72:277-291, 1976
 32. Tenover JS: Effects of testosterone supplementation in the aging male. *J Clin Endocrinol Metab* 75:1092-1098, 1992
 33. Weibel ER: *Point Counting Methods: Practical Methods for Biological Morphometry*, vol 2, pp 101-161. London, Academic Press, 1979
 34. Willard MD, Turnwald GH: *Small Animal Clinical Diagnosis by Laboratory Methods*. San Francisco, Saunders, 1989
 35. Williams PE, Goldspink G: Changes in sarcomere length and physiological properties in immobilized muscle. *J Anat* 127:459-468, 1978
 36. Zajac FE: Muscle and tendon: properties, models, scaling and application to biomechanics and motor control. *Crit Rev Biomed Eng* 17:359-411, 1989