

To the Question of Fuzzy Evaluation of Quality of Trainees Knowledge in the System of Distance Learning

Usmanov R.N., Khamidov V.S.*

Tashkent University of Information Technologies, Tashkent, 108, Republic of Uzbekistan

*Corresponding Author: vkhamidov@gmail.com

Copyright © 2013 Horizon Research Publishing All rights reserved.

Abstract The technique of computational experiments to assess the quality of the educational process in the distance learning systems based on fuzzy-set approach.

Keywords Fuzzy Logic, Fuzzy Sets, Elearning, The System of Distance Education

1. Introduction

Now the system of distance learning (SDL) is widely applied in all stages of education, which contributes to the rapid development of information and telecommunication technologies, which open new and perspective opportunities for independent study that exempts a student from the spatial and temporal constraints. One of the specific parties of SDL is learning how to study on their own [2,8].

In this regard, one of the scientific problems in the learning process in the SDL is working on information about student's progress at all stages of training, the results needed for making decision by organizing training, improving the control technologies of student's knowledge etc. It should be noted that much information relating to the education system is given in the form of verbal estimates of most parameters of the educational process, for example such as progress, the level of educational material (EM), student's abilities, etc. Traditionally, evaluation of training activities are mainly carried out on the basis of quantitative information - rating points, estimates in a five point rating scale, etc. The paper deals with the matters of application the principles of the theory of fuzzy sets (TFS) to simulate some aspects of the educational process in the SDL and the results of computational experiments (CE) based on the program of Fuzzy Logic Toolbox (FLT) of MatLab.

2. The Mathematical Formulation of the Problem

The problem of obtaining a comprehensive, objective

assessment of the quality of the organization of the learning process in the SDL depends on the extent of use on making decision processes of all available information, including quantitative information (students' rating scores, the number of missed classes, etc.), as well as qualitative data (linguistic assessment of the quality of teaching materials, student's creative abilities, etc.). It should be noted weak adaptation of traditional methods [2,4,8].

A perspective method of working on pedagogical information is the use of educational information of TFS, appearance of which is explained by the ambition a formal apparatus, which is adequate to fuzzy language of discourse. It should be noted that direct use of fuzzy, linguistic information on the process of making decision is an important point to achieve the main objectives of modeling - clarity, certainty, objectivity.

The formalization of the educational process on the basis of application principles of TFS allows us to consider the methodology of fuzzy modeling on the one hand, as an object of study, and on the other - as a matter of addressing specific educational tasks, while considering the epistemological, general methodological and psychological problems.

The simplest scheme of fuzzy-logic inference is represented as the following construction [3,4]:

$$\left. \begin{array}{l} \text{Knowledge: if } x \text{ is } A \text{ then } y \text{ is } B \\ \text{Fact: } x \text{ is } A' \\ \text{Conclusion: } y \text{ is } B' \end{array} \right\} (1)$$

Here, A, B, A', B' are linguistic variables (LP), in general presented a set of: (X, T, U, G, M) , where X - the name of the LV, T - the set of its values or terms, each of them is presented as: $(T_i, U, M(T_i))$. T is also called the base term-set, U -basic set-universe. G -syntactic rule the formation of many new values of LV of T , M -semantic rule allowing to the term T_i its meaning $M(T_i)$.

Let the student's academic performance in the SDL be estimated by using the concepts of L -Low, M -Medium, H -high. Then, formalization of fuzzy information can be carried out using LV form (Progress, T , $[0,100]$, G, M), where $T = \{T_1, T_2, T_3\} = \{N, C, B\}$ is a base term of plurality, as assessed Percentage. LP is divided into numeric linguistic

variables (NLV) and non-numeric linguistic variables (NNLV), depending on which in the scale-quantitative or qualitative-basic variable is measured.

Let $T=\{T_k\}$ - basic term set of LV of X . Using the semantic relations "and," "or" "not" using basic terms, it is possible to build composite terms T_i and T_j , T_i or T_j , T_i is not etc. which allow to produce further expansion of the base term - set. In this case, the following operations on the belonging functions (BF):

$$\mu_{A \cup B}(x) = \max(\mu_A(x), \mu_B(x)), x \in U$$

$$\mu_{A \cap B}(x) = \min(\mu_A(x), \mu_B(x)), x \in U$$

$$\mu_{\bar{A}}(x) = 1 - \mu_A(x), x \in U$$

BF of LV is based on the package of FLT of the system Matlab.

3. Materials and Methods

In the process of fuzzy modeling it may arise two problems:

Transition from received fuzzy sets to concrete numeral value

Decode received fuzzy sets (FS), that's realize linguistic approximation holding a lot of numbers, fuzzy conceptions, terms.

Based on the principles of TFS look through the process of fuzzy modeling monitoring of learning in the SDL. The structure of fuzzy-set model to assess the quality of the student of the SDL is presented as follows:

$$Y(y_1, y_2, y_3) = \tilde{f}(x_1, x_2, x_3, x_4, x_5), \quad (2)$$

Where:

- x_1 - The level of student's knowledge on student's k-cycle ;
- x_2 - The level of organization the learning process in the SDL;
- x_3 - The ways of development educational materials in the SDL;
- x_4 - E-learner ratio to training in the SDL;
- x_5 - The degree of student's preparation to work in the SDL.

y_1 -Systemation of student's knowledge;

y_2 - The effectiveness of student's knowledge;

y_3 -Strength of student's knowledge.

To select the final structure of the model (2) apply the method of paired comparisons T.Saati [10], according to which forms the matrix of paired comparisons of $A = \{a_{ij}\}$ of dimension $n \times n$, where a_{ij} assessment of the intensity to display properties on object l_i in comparison with object l_j in the scale of Saaty $\{1,3,5,7,9\}$. Estimates a_{ij} ask the experts at that $a_{ji} = 1/a_{ij}$.

Further, by an expert survey it is considered the issue of ranking parameters x_1, x_2, x_3, x_4, x_5 of the model (2).

The experts identified the following assessment of the significance of parameters on a scale of Saaty:

The level of student's knowledge and the level of organization the learning process in the SDL - 7;

The level of student's knowledge and ways of development educational materials in the SDL -5;

The level of student's knowledge to study in the SDL and ratio of students to teaching in the SDL -5;

The level of student's knowledge to study in the SDL and the degree of preparedness of the student to study in the SDL - 5;

The level of organization the learning process in the SDL and ways of the development educational materials in the SDL -7;

The level of organization the learning process in the SDL and student's relationship in the SDL -7;

The level of organization the learning process in the SDL and the degree of preparedness of the student to study in the SDL - 5;

Ways of development educational materials in the SDL and student's attitude to learning in the SDL-7;

Ways of development educational materials in the SDL and the level of preparedness of the student to study in the SDL -7;

Student's attitude to learning in the SDL and the degree of preparedness of student to study in the SDL-5.

Ranking the parameters of the model (2) is carried on in the Matlab (look at listing of numerical experiments).

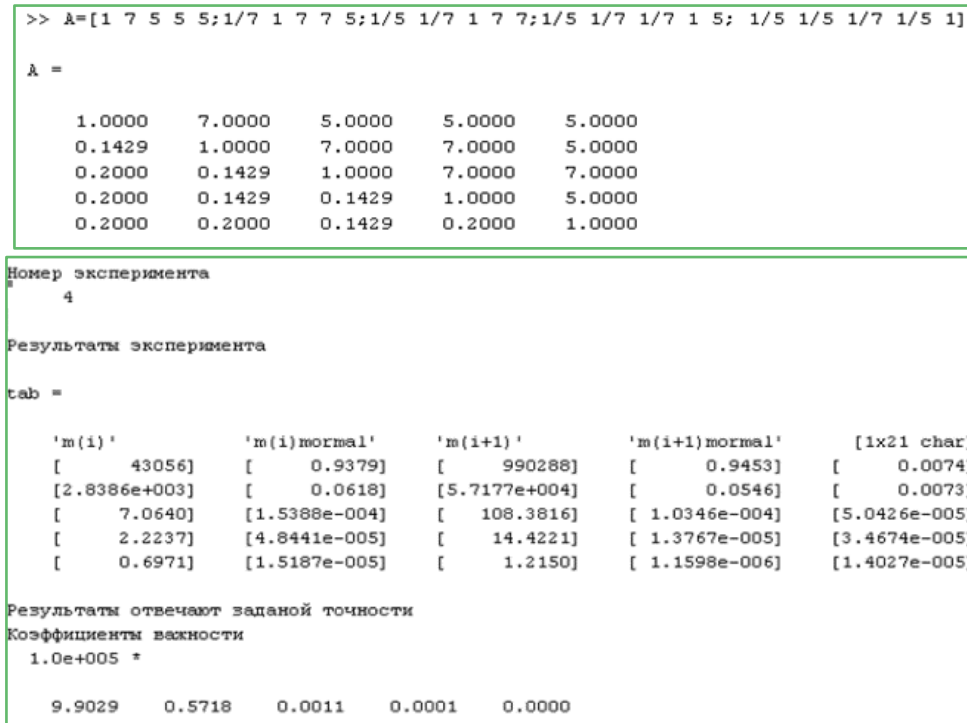

Figure 1. Listing computational experiments

According to the results of CE (see Figure 1) factors x_1, x_2, x_3, x_4, x_5 care ranged follows $x_1 > x_2 > x_3 > x_4 > x_5$.

On such a basis by the selection of the final structure of the fuzzy-logic model of assessing the quality of the student's knowledge in the LMS to present this:

$$Y(y_1, y_2, y_3) = \tilde{f}(x_1, x_2, x_3), \quad (3)$$

Monitoring changes of the level of student's knowledge is performed as shown in Figure 2.

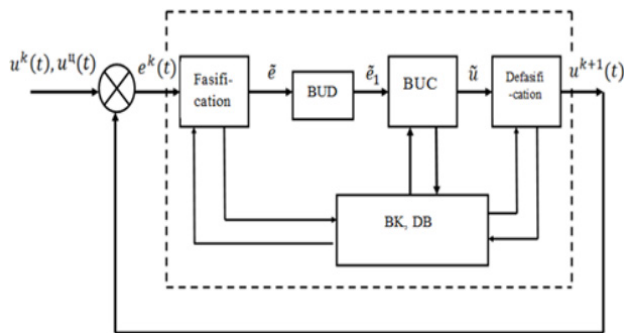

Figure.2. Schematic diagram of the fuzzy adaptive control in the SDL.

Here: BFD-block of fuzzy diagnosis the condition of the object of research (the student), CBF – block of fuzzy-logic inference, base of knowledge, database.

According to scheme it is calculated:

$$u^k(t) = \{x_1^k(t), x_2^k(t), x_3^k(t), y^k(t)\} \text{-trainee`s State on the k-cycle learning; Introduced:}$$

$$u^u(t) = \{x_1^u(t), x_2^u(t), x_3^u(t), y^u(t)\} \text{ target condition of the}$$

student; t-time;

$x_1^k(t), x_2^k(t), x_3^k(t), x_1^u(t), x_2^u(t), x_3^u(t)$ -levels of student's knowledge and training in the SDL, the methods of developing EM and their targets.

$y^k(t)$ - <Quality of education>.

$e^k(t) = u^k(t) - u^u(t)$ - Deviation of the current state of the student from the target, which may take the linguistic values.

If take \tilde{e} as a fuzzy value of $e^k(t)$ that is \tilde{e} characterized by the term - set: $T(\tilde{e}) = \{T_1(\tilde{e}), T_2(\tilde{e}), T_3(\tilde{e}), T_4(\tilde{e}), T_5(\tilde{e})\}$, where $T_1(\tilde{e})$ - <ZNN >, $T_2(\tilde{e})$ - <NN >, $T_3(\tilde{e})$ - <H >, $T_4(\tilde{e})$ - <BH >, $T_5(\tilde{e})$ - <ZVN >. Here, it is taken the following designations: ZNN - well below the norm; NN - below the norm, H - the norm; BH - above the norm; ZVN - well above the norm.

These linguistic assessments of the quality of the learning are determined with the help of testing, tests, surveys on the basis of generally accepted standards of assessment adopted in the education system. These characteristics are quite sufficient for the organization of adaptive management learning in the SDL [1,7,9].

The basis of the management system of quality of learning, presented in Figure 2 is a block fuzzy-inference based on the implementation of a fuzzy-logic model (3).

Attributes LV - x_1, x_2, x_3, y are represented by the term set in the respective universes $X, Y - X \in [0,1], Y \in [0,100]$ changing at each training cycle. Thus,

$$T(x_i) = \{T_1^i(x_i), T_2^i(x_i), T_3^i(x_i)\} \quad (4)$$

For convenience, we assume uniform notation for all terms including the LV : H - lower C - Intermediate B - high.

The database in the proposed system of adaptive management of the educational process in the SDL includes the results of the sampling, scaling, normalization of universes-fuzzy division of inputs and outputs (number of terms), determining the belonging function (BF) of the terms LV: x_1, x_2, x_3, y (Bell-shaped, triangular, trapezoidal, etc.)

The base of knowledge is a system of fuzzy rules that implement the fuzzy model of type (1). Briefly stop at the linguistic evaluations (semantics) of the terms LV x_1, x_2, x_3 and y [4,6]

$T_1^1(x_1) < H >$ - <The student has superficial knowledge by the studied subject, and the student is trying to get any positive assessment with minimal>;

$T_2^1(x_1) < C >$ - <The student has hard knowledge, and he is seeking to gain the knowledge needed for typical problems in the subject area>;

$T_3^1(x_1) < B >$ - <The student has a high level of preparedness, he is trying to get maximum knowledge which is necessary for using in practice >;

$T_1^2(x_2) < H >$ - <The training in the SDL is organized without assessing the level of preparedness of the trainee>;

$T_2^2(x_2) < C >$ - <In the selection of EM it is in the learning process it is taken into account the level of a learner, but the feedback is organized loosely>;

$T_3^2(x_2) < B >$ - <The educational process in the SDL was organized according to the level of a learner, feedback organized at the high methodological level, according to the possible limitations >;

$T_1^3(x_3) < H >$ - <The proposed method of training is inadequate to the level of trainee's preparedness >;

$T_2^3(x_3) < C >$ - <The components are the subject of interim control of the degree of assimilation of knowledge is inadequate trained partition object>;

$T_3^3(x_3) < B >$ - <Method of training is chosen by assessment of student's progress on sections of the object>;

$T_1^4(y) < H >$ - <Student's Knowledge does not meet the learning goals>;

$T_2^4(y) < C >$ - <The student obtained the necessary knowledge to solve some common tasks, while at the same time, the student has gaps on the application of acquired knowledge in solving practical problems>;

$T_3^4(y) < B >$ - <The student has sufficiently strong knowledge he knows how to use them for specific tasks>.

Implementation of fuzzy logic model of integrated assessment of the quality of the student's knowledge (1) is based on the design of production rules - a set of control rules of fuzzy logic, coupling input of the system with its output. It is used the LV adopted above, and their form - terms and their fuzzy values. Based on the introduced LV and their terms, fuzzy model of the quality of student's knowledge in the SDL can be summarized as:

If the level of preparing a learner ($x1$) = (H,C,B),
 And the level of organization of the learning process ($x2$)=(H,C,B) (5)
 And developing methods EM ($x3$) = (H,C,B),
 Then the quality of knowledge (Y) = (H,C,B),

Numerical evaluation of the quality of the student's knowledge (y^*) for specific values (numeric, linguistic) of the parameters x_1^*, x_2^*, x_3^* quantitatively determined by

defuzzification on the basis of the center of gravity [3,4].

Diagnostic unit in the adaptive management of the educational process is based on the definition of strategy decisions made on the basis of the fuzzy analysis of the situation, according to which all the information delivered to the input of the system ($e^k(t)$) is fuzzified and defined a set of typical situations, which refers to lots of the most typical situations, as well as many target situations. Fuzzified information supplied to the input block of diagnostics is presented in the form of fuzzy current situation, that is compared with the target situation. In result it is determined the object state of the control object, taken control solutions that are implemented on the fuzzy-logic inference.

The process of PR begins with the definition FP of parameters of the situation [6]:

$$\Delta u^k(t) = \{\Delta x_1^k(t), \Delta x_2^k(t), \Delta x_3^k(t), \Delta y^k(t)\}. \quad (4)$$

Where

$$\Delta x_i^k(t) = x_i^k(t) - x_i^u(t); \quad (5)$$

$$\Delta y^k(t) = y^k(t) - y^u(t);$$

$$i=1,2,3 \quad \Delta u^k(t) = u^k(t) - u^u(t);$$

On the basis of (4) it is calculated the current values of FP [6]

$$\mu_i^k = \begin{cases} \frac{a_i^k - a_i}{\tilde{a}_i - a_i}, & a_i \leq a_i^k \leq \tilde{a}_i \\ \frac{\tilde{a}_i - a_i^k}{\tilde{a}_i - a_i}, & \tilde{a}_i \leq a_i^k \leq \bar{a}_i \end{cases}, \quad (6)$$

According to the value of μ_i^k it is determined the fuzzy evaluations of signs of x_1, x_2, x_3, y the object of research. It is used the structures of the form:

$$\langle \Delta \tilde{x}_i, X, \tilde{C}_{(i)} \rangle, \quad \langle \Delta \tilde{y}, Y, \tilde{C}_{(y)} \rangle, \quad (7)$$

where

$$\left. \begin{aligned} \tilde{C}_{(i)} &= \{ \langle \alpha_i / T_1^i \rangle, \langle \beta_i / T_2^i \rangle, \langle \gamma_i / T_3^i \rangle \}, \\ \tilde{C}_{(y)} &= \{ \langle \alpha_y / T_1^4 \rangle, \langle \beta_y / T_2^4 \rangle, \langle \gamma_y / T_3^4 \rangle \}, \\ a_i &= \{ \Delta \underline{x}_i, \Delta \underline{y} \}, \quad \tilde{a}_i = \{ \Delta \tilde{x}_i, \Delta \tilde{y} \}, \\ \bar{a}_i &= \{ \Delta \bar{x}_i, \Delta \bar{y} \}, \quad \Delta \underline{x}_i < \Delta \tilde{x}_i < \Delta \bar{x}_i, \quad \Delta \underline{y} < \Delta \tilde{y} < \Delta \bar{y} \end{aligned} \right\}$$

a_i, \bar{a}_i - Lower and upper value of fuzzy numbers; $\Delta \tilde{x}_i, \Delta \tilde{y}$ on α -zero level; \tilde{a}_i - The averages of these numbers on a single α -level.

Adaptive control is implemented on the basis of the

following fuzzy operators [5]:

$\langle G, T_G, X \rangle, \langle L, T_L, X \rangle, \langle Z, T_Z, X \rangle$ where G, L, Z - LV wherein, G-<reinforce>, L-<decrease>, Z - <not modify> $X \in [-1, 1]$.

The components of the term – the sets of LV G, L are <a bit much>;

The control solutions are designed on the basis of changes terms of LV G, L, Z.

An effective means of realization complex approach in organization, planning and management of the OP in the SDL is a software package Fuzzy Logic Toolbox (FLT) functioning in MatLab [3,6].

Simulation of the OP in the FLT should be divided into the following interrelated steps [3,4,6]:

Definition input and output parameters of the model ;

Projection database and base of knowledge to develop fuzzy models of Mamdan's type ;

Leading CE on the base built by the fuzzy model;

Accepting pedagogical decision and reference on the base of adaptation results of CE;

For the convenience all input and output variables (x_1, x_2, x_3, y) are characterized by the same term set $T = \{\text{low, medium, high}\}$ in a single universe of points $[0, 100]$.

Fuzzy model of assessing the quality of the student's knowledge on the basis of (3) is represented as follows:

$$y = \tilde{f}(x), \quad (8)$$

In the process of implementation of the model (8) on the FLT it is taken the following notation:

$x_1 \sim \text{UPO}; x_2 \sim \text{UOPO}; x_3 \sim \text{SPOSOB}; y \sim \text{CHOB}.$

At the same time, user-friendly interface and graphical capabilities of the system of FLT allow FLT to plan and carry out CE on the basis of projected fuzzy-logic model.

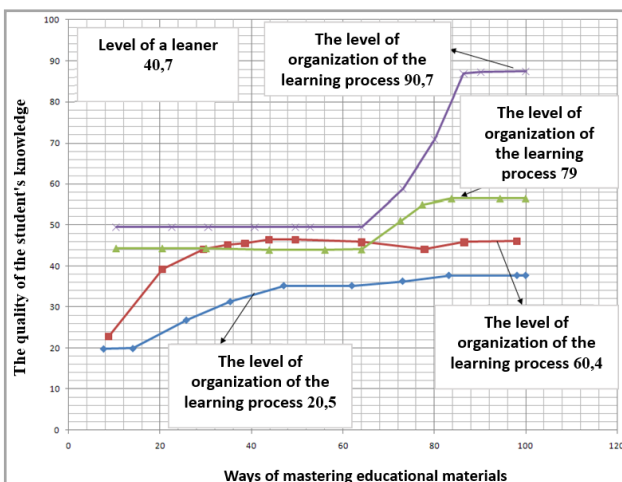

Figure 3. The results of CE-based on the interactive model of the OP in FLT.

It was lead a series of CE-based FLT models, the result of which is shown in Fig. 3.

4. Discussion

The results of the CE show that at the level of a learner, which is close to the bottom ($\approx 40, 7$) it is a very significant enhancement works on implementation of advanced learning technologies (Figure 3).

Since one of the defining elements of productivity of the SDL is adequate definition of the level of student's knowledge in the k-th cycle of training, it is necessary to highlight the issues related to the assessment of quality of knowledge, including a comprehensive assessment of such parties as the fullness, depth, speed, flexibility, contrast, Hide , regularity, consistency and awareness of knowledge [8].

5. Conclusion

In conclusion, we note that the effectiveness of computer-based training systems is largely determined by drawing the methodological aspects of assessment of the learner's mastering the subject being studied, timely diagnosis of detection, prevention elements of the backlog, as well as an adaptive decision addressing to their removal.

REFERENCES

- [1] A.V. Solovov Projection of computer systems of educational destination; Samara's educational handbook; SGAU, 1995-138 p.
- [2] Mixeev V.T. Modelling and methods of the theory of measurement in pedagogics. M. High school ., 1987-200 p.
- [3] A.V. Leonenkov Fuzzy modeling in Matlab and FUZZY TECH – SPB, BXV – Peterburg, 200-736 s.
- [4] R.N. Usmanov, V.Khamidov To the question of integration principles of the theory of fuzzy sets in modeling pedagogical processes/ messenger of TUIT; 2009, №1, C, 113-118.
- [5] Melixov A.N., Bershteyn S.Y. Situational advised systems with fuzzy logics – M: Science., 1990-272 s.
- [6] RN Usmonov, VS Khamidov. Working out The Principles of Adaptive Management to Educational Processes in the E-Learning / Applied Mathematics.USA / 2011, 1 (1): 1 - 4 / p-ISSN: 2163-1409.
- [7] S.V. Astanin., T.G. Kalashnikova. Development individual models of trainee's behavior in the SDL.// Perspective information technologies and intellectual systems., №1 (5), 2001, <http://pitis.tsure.ru/>
- [8] The quality of trainee's knowledge and ways of it's development. Under M.N. Skatkin's wording

- <<Pedogogics>> 1997, 208 s.
- [9] A.N. Alekseev. Distance learning for engineering specialists ITD. <<A book for students of university>> 2005, 333 p.
- [10] Saaty TL, Measuring the fuzziness of sets, J. Cybernetics 4, 53-61, 1974.