

LLNL-PROC-484033



LAWRENCE
LIVERMORE
NATIONAL
LABORATORY

Axisymmetric Magnetic Mirror Fusion-Fission Hybrid

R. W. Moir, N. N. Martovetsky, A. W. Molvik, D. D.
Ryutov, T. C. Simonen

May 13, 2011

15th International Conference on Emerging Nuclear Energy
Systems
San Francisco, CA, United States
May 15, 2011 through May 19, 2011

Disclaimer

This document was prepared as an account of work sponsored by an agency of the United States government. Neither the United States government nor Lawrence Livermore National Security, LLC, nor any of their employees makes any warranty, expressed or implied, or assumes any legal liability or responsibility for the accuracy, completeness, or usefulness of any information, apparatus, product, or process disclosed, or represents that its use would not infringe privately owned rights. Reference herein to any specific commercial product, process, or service by trade name, trademark, manufacturer, or otherwise does not necessarily constitute or imply its endorsement, recommendation, or favoring by the United States government or Lawrence Livermore National Security, LLC. The views and opinions of authors expressed herein do not necessarily state or reflect those of the United States government or Lawrence Livermore National Security, LLC, and shall not be used for advertising or product endorsement purposes.

Axisymmetric Magnetic Mirror Fusion-Fission Hybrid (LLNL-PROC-484033)

R. W. Moir¹, N. N. Martovetsky¹, A. W. Molvik¹, D. D. Ryutov¹, T. C. Simonen²

¹Lawrence Livermore National Laboratory, Livermore, CA USA, ralph@ralphmoir.com, martovetskyn@ornl.gov,
AWMolvik@lbl.gov, ryutov1@llnl.gov

²University of California, Berkeley, CA USA, simonen42@yahoo.com

ABSTRACT

Early application of the simple axisymmetric mirror, requiring intermediate performance between a neutron source for materials testing $Q=P_{\text{fusion}}/P_{\text{input}} \sim 0.05$ and pure fusion $Q > 10$, are the hybrid applications. The Axisymmetric Mirror has attractive features as a driver for a fusion-fission hybrid system: geometrical simplicity, as well as the typical mirror features of inherently steady-state operation, and natural divertors in the form of end tanks. This level of physics performance has the virtue of being low risk with only modest R&D needed; and its simplicity promises economy advantages. Operation at $Q \sim 1$ allows for relatively low electron temperatures, in the range of 3 keV, for the DT injection energy ~ 80 keV from existing positive ion neutral beams designed for steady state. A simple mirror with the plasma diameter of 1 m and mirror-to-mirror length of 40 m is discussed. Simple circular steady state superconducting coils are based on 15 T technology development of the ITER central solenoid. Three groups of physics issues are presented: axial heat loss, MHD stability, and microstability of sloshing ions.

Burning fission reactor wastes by fissioning transuranics in the hybrid will multiply fusion's neutron energy by a factor of ~ 10 or more and diminish the Q needed to overcome the cost of recirculating power for good economics to less than 2 and for minor actinides with multiplication over 50 to $Q \sim 0.2$. Hybrids that obtain revenues from sale of both electricity and production of fissile fuel with fissioning blankets might need $Q < 2$ while suppressing fissioning might be the most economical application of fusion but will require $Q > 4$.

I. INTRODUCTION

Mirrors have a number of attractive features as future fusion devices: they have simple linear geometry to ease construction and maintenance, are inherently steady state, operate at high beta, have no externally driven currents, and have natural divertors to handle heat loads external to the magnet system that also reduces first wall heat loads.

Over the past decades, largely after the termination of the mirror program in the US, several techniques have been suggested and, in some cases, tested experimentally, for making mirrors stable in axisymmetric geometry. The

confidence in the practicality of axisymmetric MHD-stable mirrors has increased significantly after a set of experiments conducted in 2005-2010 on the upgraded axisymmetric mirror machine GDT at Novosibirsk [1]. It routinely operates at a plasma beta equal to 0.6 and average ion energy of a few keV, with the plasma axial losses being in a good agreement with the classical predictions. Its important feature is being fully axisymmetric and, at the same time MHD – stable. A significant role in making this device MHD stable is played by the out flowing plasma, which, on the one hand, provides a favorable contribution to the stability integral of [2] and, on the other hand, provides an electric contact with the conducting end wall. Applying radial potential to the segmented limiter is transferred to the confinement zone along the field lines and may further improve stability [3,4]. This technique can be used in a fusion neutron source, which will operate at plasma Q of order of a few percent [5].

The attractive features of mirrors are tremendously amplified in the case of axial symmetry. In particular, neoclassical and resonant transport are completely eliminated; engineering simplicity and general flexibility of the device increase significantly; much higher magnetic fields become available for mirror throats, etc. Axisymmetry is thus a game-changer in mirror systems!

The parameters already attained in the GDT experiment make a strong case for the feasibility of a neutron source for materials and subcomponent testing [5]. The neutron source version of this device is attractive with no (or with a minor) extrapolation of the plasma parameters from the existing experiment [1]. It operates at a low level of the fusion gain Q , of order of a few percent. This allows one to fully exploit the stabilization by the out flowing plasma and makes the operation scenario of the neutron source quite simple.

In this paper, we concentrate on the use of an axisymmetric mirror as a driver for a fusion-fission hybrid [6]. In order to have a meaningful power balance of this system, the fusion driver has to have a much higher value of Q than the neutron source. A physics background for this more challenging application has been assessed in [7], where plausible stabilization techniques have been identified and other plasma physics issues affecting the driver performance have been analyzed. The result was a simple, single cell mirror device with large expansion tanks at the ends.

Fusion-fission hybrids can potentially be used to produce energy, to breed fuel for fission reactors, to “burn” the most hazardous waste of fission reactors, or perform some combination of these functions [8]. We do not try to be very specific with regard to a possible best application of a mirror driver. We show that it is compatible with a broad variety of blankets and can perform any of the aforementioned functions. We discuss the requirements for the main systems of the facility: neutral beam injection system, gas feed and vacuum systems, magnetic system, tritium breeding and, of course, blanket and shield. We identify areas where the required technologies and components are available today and where some further development is needed.

Producing ^{233}U from thorium has both proliferation advantages and concerns. ^{232}U that inevitably accompanies ^{233}U production makes the material undesirable but not impossible for use in fission weapons. Fusion’s 14 MeV neutron being well above the threshold for making ^{232}U can enhance the $^{232}\text{U}/^{233}\text{U}$ ratio from its usual value of $\sim 0.1\%$ to $\gg 1\%$. This enhances the generation of both 2.6 MeV gamma rays and decay heat that facilitates detection of stolen material and makes for weapon design problems.

The rest of the paper is structured as follows: In Sec. II, a general scheme of the mirror driver is described and a summary of the physics issues and main plasma parameters is presented, the neutral beam injection system is described, the superconducting magnetic system is presented, the structure of the end tanks is characterized, together with a vacuum and direct energy conversion systems, and the tritium system is briefly assessed. In Sec. III, the Q required for favorable economics is discussed. In Sec. IV, the structure of the blanket is described. In Sec. V the pure fusion axisymmetric mirror is described. In Sec. VI is the Development path. Finally, Sec. VII and VIII contain summary and discussion and conclusions.

Our main conclusion is that the hybrid driver in the form of an axisymmetric mirrors can be built based mostly on either the existing technologies or technologies that will be needed in any of the fusion energy systems (like, e.g., tritium breeding).

This paper is a summary of a more complete report [9].

II. A GENERAL SCHEME AND A SUMMARY OF THE PHYSICS PARAMETERS

Schematic of the system is presented in Fig. 1 and its parameters are summarized in Table 1. Atomic beams are injected normally to the magnetic axis near the ends of the confinement region where the magnetic field is ~ 2 times higher than in the uniform part of the facility. The maximum magnetic field (in the mirror throat) will be 3-4 times higher than that in the injection point, this means

the injected ions are well confined. In this uniform section the ions will have a “sloshing” distribution, with the average pitch-angle of 45° . Such a distribution was proven to possess good micro-stability [10]. The sloshing distribution is compatible only with relatively cold electrons, so that the slowing-down time is shorter than the ion scattering time. To hold the electron temperature low, at the level of 3 keV, we envisage injection of cold atomic streams in the zone between the mirrors and the ion turning points. The distance to the latter has to be large-enough to minimize penetration of atoms to the zone with significant hot ion population, in order to minimize charge exchange losses.

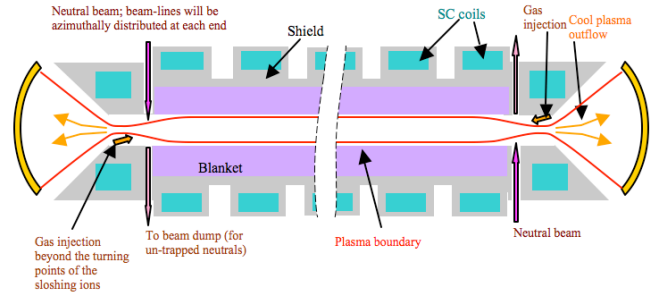

Fig. 1. Schematic of a simple axisymmetric mirror as a driver for fusion-fission hybrid.

TABLE 1. Characteristic parameters of a mirror driver

| | |
|---|----------------------|
| Plasma radius ¹ , m | 0.5 |
| Mirror-to-mirror length, m | 40 |
| Length of a reacting plasma ² , m | 35 |
| Volume of a reacting plasma ² , m ³ | 25 |
| Plasma surface area ² , m ² | 100 |
| Injected ion energy ³ , keV | 80 |
| Average ion energy ³ , keV | 40 |
| Average ion density, m ⁻³ | 10^{20} |
| Electron temperature, keV | 3 |
| Peak ion density, m ⁻³ | 1.3×10^{20} |
| Z_{eff} ⁴ | 1.2 |
| Magnetic field, T | 2.5 |
| Mirror field, T | 15 |
| Volume-averaged beta | 0.25 |
| s = plasma radius/ average ion gyroradius | 30 |
| NBI trapped power, MW | 65 |
| Plasma Q | 0.7 |
| Fusion power, MW | 45 |
| Neutron power, MW | 36 |
| Neutron wall load, MW/m ² @ 0.6 m | 0.27 |
| Power to end tanks, MW | 75 |

¹ In the midplane

² Between the turning points of the sloshing ions

³ Ignoring $1/2$ and $1/3$ energies

⁴ Based on the previous experience with large-scale mirror facilities and composition of the injected particle beams [11].

Injected gas, after having been ionized, flows out of the facility to the end tanks and establishes an electrical contact of the confinement zone with the conducting wall. This provides conditions for suppression of the large-scale flute perturbations via the partial line-tying. The growth rate of instability decreases by an order of magnitude compared to its un-inhibited value. The residual slow instability can be stabilized by other techniques, like feedback stabilization.

The flaring of the magnetic field in the end tank allows one to reduce the heat flux on the plasma absorbers to a manageable level of 1 MW/m^2 . For the parameters of Table 1, this requires the surface area of each of the absorbers to be $\sim 40 \text{ m}^2$, meaning that the magnetic field at the end surface will be $\sim 0.05 \text{ T}$. Strong flaring leads to a formation of the ambipolar potential between the mirror throat and the end-wall; this potential barrier repels most of the electrons back to the mirror and reduces the electron heat loss to a small level.

More detailed description of the physics processes can be found in Ref. [7], together with further references.

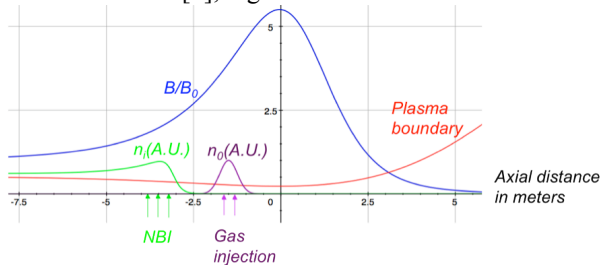

Fig. 2. The vicinity of the mirror. Horizontal coordinate is the distance from the mirror point in meters. Blue line: the magnetic field strength normalized to its value at the uniform part of the device. Red line: the plasma radius in meters; on the uniform part the plasma radius is 0.5 m. Green arrows indicate injection zone of the neutral beams 80 cm long). The green line is the density of fast ions normalized to its maximum value. The magenta arrows indicate the injection zone of slow atomic particles ($\sim 50 \text{ cm}$ long). The magenta line is the density of these slow atoms. Note that there is no overlap between the fast ion and cold atom population.

Plasma sustainment and control systems

In order to provide some insight into the technical readiness of various systems needed for the construction of the fusion ‘core’, we briefly outline a possible overall design. We expect a facility like this to be preceded by a neutron source that will develop steady-state neutral beams (possibly with direct conversion of the unneutralized ion beam), cryopanel with regeneration, tritium-generating lithium blankets, and fusion-fission hybrid blankets.

Magnetic system

The magnet system consists of two subsystems – a long solenoid with 2.5 T central field and mirror

solenoids at the end with a high field of 15 T. The long solenoid is quite feasible with NbTi superconductor [9]. The engineering current density in the coil with the winding pack 60 mm thick without gaps will be 33.2 A/mm^2 , which is quite achievable. It will be thicker winding or higher current density if gaps will be introduced, but still quite achievable at reasonable optimization of the magnet. The least expensive design will be based on the technology developed for HEP detectors – indirect cooling inside a strong aluminum tube, supporting hoop stresses [12]. Then it will be sufficient to have 40 mm thick cylinder to support hoop stresses, which is also quite feasible.

The 40 m long magnets will store about 1.25 GJ, which can be evacuated in the event of the quench on a dump resistor with several kV dump voltage. Taking into account a large operating margin that can be provided, design of the solenoid with access gaps is quite feasible.

Another option for such a solenoid is a self-supported solenoid made out of the cable-in-conduit conductor (CICC) that will have a jacket strong enough to support hoop stress without a massive structure. The conductor is cooled by forced flow supercritical helium. This technology is well developed in fusion community and used in ITER machine, under construction in France [13].

The 15 T mirror solenoid is feasible but at the state-of-the-art level with the today’s technology. A close to the required parameters is the 13 T peak field Central Solenoid Model Coil (CSMC) [14] built by ITER collaboration in 1999, see Fig. 3. There has been a significant progress in superconducting materials since 1999, although structural materials, that occupy most of the winding pack, did not improve that much since then. The ITER CS under design and development that will generate 13 T in a bore 2.6 m ID has only 25% thinner winding pack despite using a superconducting strand that is capable of carrying twice the current of the CSMC strand. The CSMC facility is functional and may be used for development of a conductor for 15 T mirror.

The magnet system feasibility for the hybrid is discussed in [9] in more details.

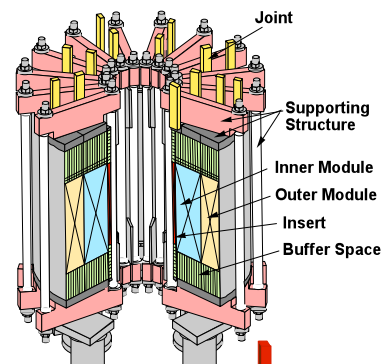

Fig. 3. Central Solenoid Model Coil (CSMC) Facility.

Plasma sustainment and exhaust

The power density to the end-wall is not the serious problem in mirror machines as it is to divertor strike surfaces in tokamaks, because we are free to expand the plasma cross section to a large area, to reduce the power density below any reasonable threshold desired. To keep end-wall sputtering to $\leq 560 \mu\text{m}/\text{yr}$, we expand the plasma radius from 0.2 m at the mirror to 3.5 m at the end wall.

We find that end-cell pumping is an issue with too much charge exchange so direct converter efficiency is low for this fusion-fission hybrid because we have selected a fusion gain of not quite unity, $Q \leq 1$. This means that end losses are large. [For pure fusion, where Q needs to be >10 , this ceases to be an issue, because the end-loss currents decrease nearly as Q^{-1} .]

A possible solution is to add gas (to limit T_e to ~ 3 keV) at only one end, reduce the cryopump area at that end to allow a high gas pressure (perhaps as high as 6×10^{-5} torr), which causes most ions to charge exchange, prohibiting efficient direct conversion of the end-loss power at that end; but at the other end with only hot-ion end losses, a reasonable area of cryopumps can reduce the gas pressure to $\sim 5 \times 10^{-6}$ torr. There $\leq 10\%$ of the ions undergo charge-exchange, so their energy can be efficiently recovered with direct conversion.

Gas injection will be located beyond the turning point of energetic beam-injected ions, and near the peak magnetic field at the mirror. The exact location will be optimized to minimize hot-ion loss through charge-exchange on injected gas by moving the injection away from the neutral beam injection location and towards the mirror or even outside of it.

Separation of tritium from deuterium, hydrogen, and other impurities has been demonstrated at Los Alamos on the Tritium Systems Test Assembly (TSTA) [15]. This is a known technology, but is quite expensive for the large flow rates envisioned for a fusion-fission hybrid. We therefore propose to use a near 50:50 mixture of deuterium and tritium, thereby minimizing the amount of isotope separation needed. The flow rate of tritium circulating in the system is ~ 0.6 kg/hr, ~ 0.22 kg/hr to the end tank pumps, and ~ 0.34 kg/hr to the neutral beam line pumps. This is about 33% of the ITER tritium flow rate of 1.8 kg/hr [16, p 145].

Long-pulse neutral beam accelerators on TFTR, and DIID [17,18,19] have demonstrated reliable operation at durations of a few seconds, these durations exceed ten thermal time constants of the accelerator electrodes, and so they are effectively steady-state cooled. Direct conversion of the power in the unneutralized portion of the beam was demonstrated on 0.5 s pulsed neutral beams [20]. The self-space charge of the ion beam expanded it into retarding electrodes located along both

broad sides of the rectangular beam that then collected the ions at low energy of a few keV. As we show in the next section, increases in beam efficiency have a particularly large-favorable effect on the efficiency and economics of operation near $Q \sim 1$; so we suggest developing steady-state direct converters as part of the neutral-beam line.

We suggest focusing the neutral beams on the aperture to the plasma; this allows injecting through the smallest possible aperture, which will be part of the neutron shield; thereby minimizing the neutron flux into the neutral beam lines. Minimizing neutrons is essential to minimize the neutron heat load to cryopanel, and to maximize the lifetime of beamline components, especially the insulators, against degradation by neutrons [21,22,23]. Focusing the neutral beams is conceptually simple. The long-pulse accelerator electrodes are hollow tubes, carrying coolant, which is tritium compatible (not water). By slightly curving the tubes, beams will be focused in one plane to the center of curvature. By also curving the surface the tubes are mounted on (as was done with short pulse (20 ms) neutral beams used on TMX-U [24], and tested with 500 ms 80 keV neutral beams intended for MFTF-B [25] ion beams can be focused in two planes.

Linear, axisymmetric systems like magnetic mirrors provide attractive options for maintenance. Cylindrical symmetry is convenient because all sides of the system are accessible, with no need to squeeze components into the donut hole of a torus. If we locate the vacuum walls outside of the blankets and neutron shields where it is protected from neutrons for a long-reliable life, then access to the blankets can be obtained by rolling the ends of the facility outwards on rails. Vacuum seals can be bolted hard seals, or edge-seam-welded sheet-metal. The latter can be opened by grinding off the weld; then rewelded after closing up, as is done daily on some industrial ovens.

III. Q REQUIRED FOR FAVORABLE ECONOMICS

A detailed model of the mirror fusion-fission hybrid would allow us to determine the fusion performance especially Q (=fusion power/absorbed power) to make any particular system economical be it a fuel producer, actinide burner or power only. In lieu of having a detailed economic model, we take as a figure of merit, $F_{\text{recirculating}} = \text{recirculating power to the injector system/gross electrical power}$ because it will turn out revenues from the sale of electricity will be important even for fuel production or actinide burning. The power flow diagram is shown in Fig. 4.

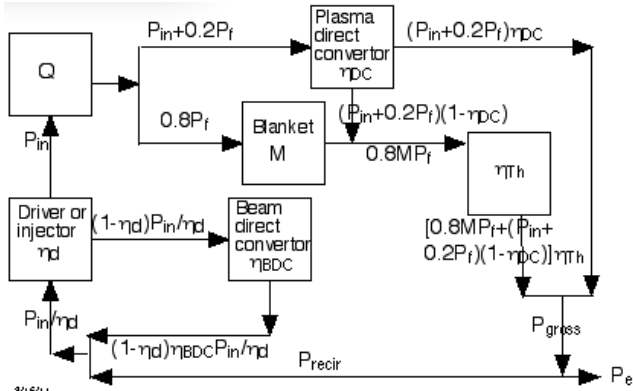

Fig. 4. Power flow diagram for axisymmetric mirror hybrid.

We include direct conversion of end loss plasma flow and of unneutralized ions in the neutral beams.

η_{th} =thermal conversion efficiency, typically = 0.4.

η_d =efficiency of converting electrical energy into neutral beam power trapped in the plasma = 0.5.

η_{BDC} =efficiency of conversion of unneutralized beam, i.e., beam direct conversion =0.5 for our examples.

η_{DC} =efficiency of plasma direct conversion of end losses, typically 0.5 for our examples. Our figure of merit, F_{recirc} is plotted in Fig. 5 for values of the blanket energy multiplication by nuclear reactions, M of 1.34, 2.1, 10 and 20 that spans from pure fusion, fission suppressed thorium hybrid, fast-fission hybrids and certain actinide burners all of which are discussed in Sec.IV.

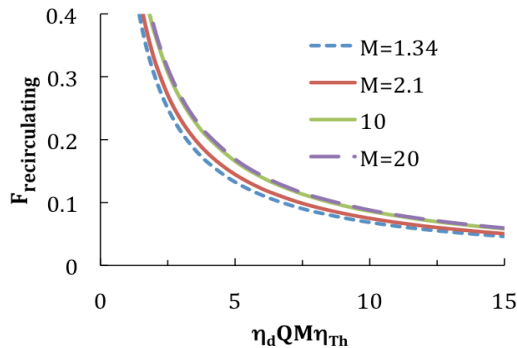

Fig. 5. Recirculating power fraction figure of merit versus $\eta_d Q M \eta_{th}$.

Based on experience, serious economic loss occurs for $F_{recirc} > 0.2$ the quantity $\eta_d Q M \eta_{th}$ should exceed 3 to 4 or 6 without direct conversion. This means Q should be greater than 8 for the $M=2.1$ blanket and 2 for the $M=10$ or 20 blankets. Another way of gauging economics is to look at the annual revenues from the sales of electricity and fuel sold or actinide destroyed by fission. For example if we sell ^{233}U for 50\$/g and electricity for 50\$/MWeh then we get the revenues plotted against Q shown in Fig. 6 and 7, where the numbers along the top

curves are the recirculating power fractions from Fig. 4.

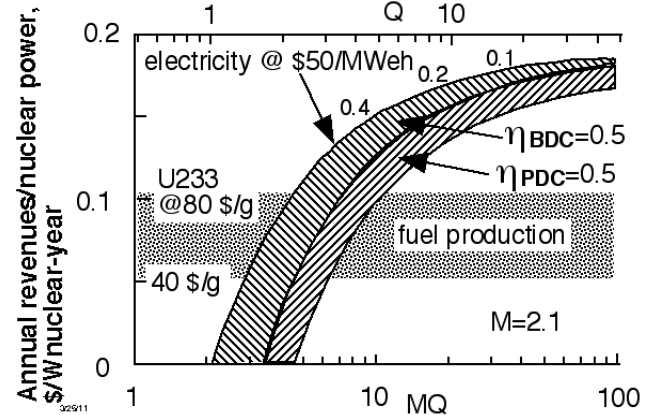

Fig. 6. Annual revenues for both fuel and electricity sales versus Q and QM for the fission suppressed fusion breeder when producing 0.6 fissile atoms per fusion event and $M=2.1$.

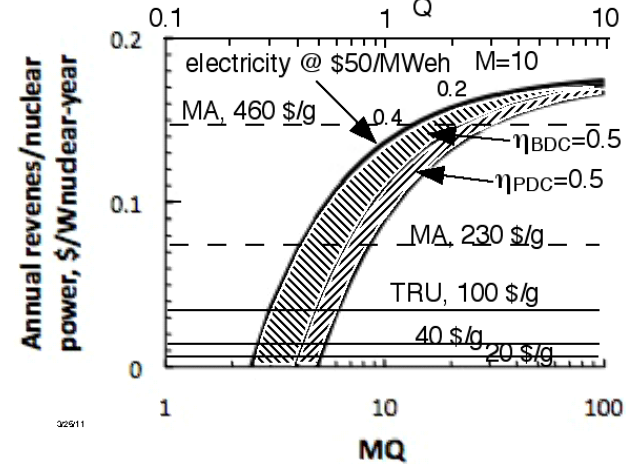

Fig. 7. Annual revenues for both actinide burning and electricity sales versus Q and QM for the actinide burning hybrid $M=10$.

IV. HYBRID BLANKET DESIGNS: ACTINIDE BURNER, FUEL PRODUCER AND POWER PRODUCER

Fission-suppressed fuel producing hybrids maximize safety and the amount of fuel production, uses helium cooling of beryllium pebbles to multiply neutrons and molten salt slowing flowing through tubes to both breed tritium and ^{233}U . Producing ^{233}U from thorium has both proliferation advantages and concerns. ^{232}U that inevitably accompanies ^{233}U production makes the material undesirable but not impossible for use in fission weapons. Fusion is unique compared to fission in its role of making ^{233}U . Fusion's 14 MeV neutron being well above the threshold for making ^{232}U can enhance the $^{232}\text{U}/^{233}\text{U}$ ratio from its usual value in fission reactors of $\sim 0.1\%$ to $\gg 1\%$. This enhances the generation of both 2.6 MeV gamma rays and decay heat that facilitates

detection of stolen material and makes for weapon design problems.

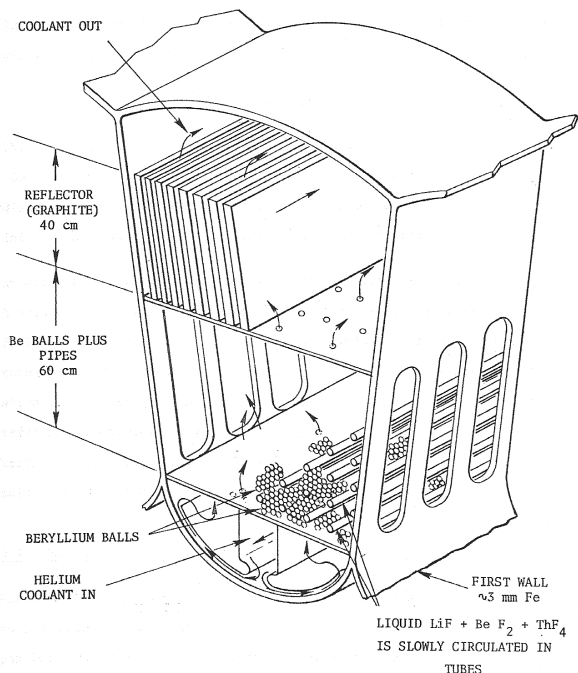

Fig. 8. Blanket submodule designed both for a tandem mirror [26] and a tokamak [27] with pebbles and helium cooling.

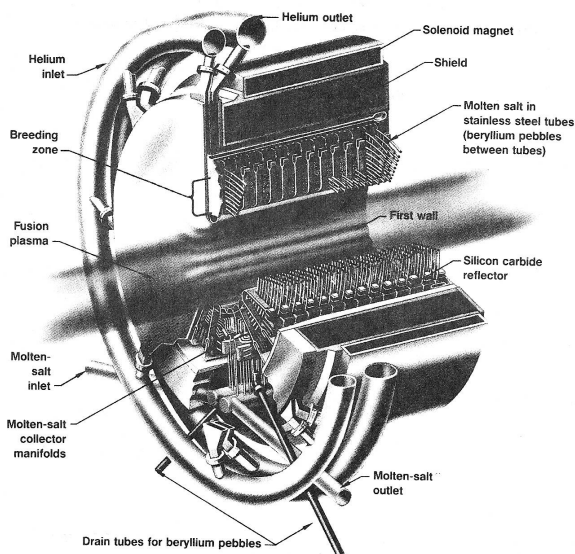

Fig. 9. Submodule adapted to mirror geometry making an integrated package of first wall, blanket, shield and solenoidal magnet.

The performance of the blanket shown in Fig. 8 & 9 is $M=2.1$ and 0.6 ^{233}U atoms are produced for each fusion event. Safety is enhanced by fission being suppressed, therefore fewer fission products and in the event of a failure, the molten salt can be passively drained to safe passively cooled storage tanks. As mentioned in the previous section the Q should be >8 for a first approximation of economics but perhaps for 40%

recirculating power, $Q>4$ might be allowed. Typical parameters of this blanket are given in Table 2.

TABLE 2. Molten salt blanket parameters.

| | |
|-----------------------------|---|
| P_{nuclear} | 4440 MW |
| P_{fusion} | 3000 MW |
| $P_{\text{alpha particle}}$ | 600 MW |
| P_{blanket} | 3840 MW |
| P_{electric} | 1380 MW |
| $P_{\text{wall load}}$ | 2 MW/m ² |
| Length of blanket | 127 m |
| First wall radius | 1.5 m |
| T | 1.1 |
| F_{net}^* | 0.6 |
| M^* | 1.6 |
| Fissile production | 6380 kg ^{233}U /yr at 80% capacity factor |
| Total cost | \$4870 M (1982\$) |

* F_{net} is the fissile atoms bred/triton consumed. M is the energy released in the blanket per triton consumed divided by 14 MeV. More recent studies gives $M=2.1$ as mentioned above.

Waste burning of transuranic elements ($A>92$) by fission in a tokamak has been studied by [28] where fuel elements are made up of separated wastes and cooled by liquid sodium. Similar studies of minor actinide (transuranics other than plutonium) burning have been carried by [29] for fissioning in a normal conducting spherical tokamak also with liquid metal cooling. Both these designs require active cooling of afterheat. A transuranic burner using molten salt with passive cooling of afterheat was studied [30].

V. AXISYMMETRIC MIRROR AS A PURE FUSION DEVICE

In order to be economical a pure fusion reactor must have sufficiently small amount of recirculating power. As can be seen from Fig. 5, in order to keep the recirculating power less than 20%, we get the following requirement on Q :

$$\eta_d Q M \eta_{th} > 3$$

$$\text{for } \eta_d = 0.7; M = 1.34; \eta_{th} = 0.4 \quad Q > 11$$

To develop a mirror into an attractive pure-fusion reactor, that is, to achieve $Q > 11$, one has to use ambipolar end plugs (see for example Ref.[31, 32]). As these plugs will now be axisymmetric, their magnetic field can be made significantly higher than in 1980s designs, and their volume much smaller. This allows using a simple tandem mirror plugs, without resorting to more sophisticated concepts like thermal barriers. The MHD stabilization schemes (of which many have been proposed and some

have even underwent preliminary tests) would have to be tested at a small-scale (similar to the existing GDT) facility.

VI. DEVELOPMENT PATH FOR NEUTRON SOURCE, HYBRID, AND PURE-FUSION DEVICES

We expect that a neutron source will be developed and operated before a hybrid device, in order to ensure reliable operation of steady-state neutral beams, cryopumps with regeneration techniques to achieve steady-state pumping, tritium generating lithium blankets, and fission-materials blankets. Whether the neutron source is a mirror or a tokamak, technology developments equivalent to those discussed above are necessary.

Development of axisymmetric mirrors for the aforementioned applications can be achieved at a relatively low cost due to the engineering simplicity of axisymmetric mirrors. These facilities are remarkably flexible: adding or removing axisymmetric coils, to test new configurations, can be done without changing the overall structure of the device. As an example, a small-volume ambipolar plug was installed and successfully tested at the GDT facility. In the past, construction of more complex facilities, like TMX, took about 1.5 years after decision to build them. The GDT facility at Novosibirsk was built in about 1 year.

One of the paths to construction of the neutron source could be as follows. Building a pulsed (20 ms) hydrogen model and demonstrating that absolute (not scaled!) values of the plasma parameter are achievable (3 years) then develop steady-state technology (common to all MFE systems) and building a neutron source (5 years). The neutron source will be first operated with hydrogen and will later be switched to a DT mode. The times here are counted from the decision point.

Performance tests of the mirror as a driver for the actinide burner can be carried out at the same facility as that built to reach design values of parameters for the neutron source. This can be done by small modifications of the geometry and reconfiguring the beam injectors, in parallel or after the neutron source-related experiments.

Stabilization techniques required for a pure-fusion reactor can be tested in an experiment of the scale of the present GDT device.

VII. SUMMARY AND DISCUSSION

The Q required for several different hybrid blankets designed for different purposes are given in Table 3. Actinide waste incineration or burning by fissioning can be accomplished with fusion neutrons. Blankets can use solid fuel forms or molten salt fuel form. With solid fuel forms, cooling of after-heat requires active or engineered safety systems. By comparison, with molten salt fuel

forms, the fuel can be drained passively during off-normal conditions to passively cooled dump or storage tanks. The recent Fukushima accidents remind us of the desirability of “walk away” or passive safety of nuclear systems.

TABLE 3. Require Q for various versions of the hybrid for the recirculating power fraction = 0.2,

$$P_{\text{nuclear}}=3000\text{MW}$$

| Actinide burner | | | Comments |
|---|-----------------------|--------------------------|--|
| Blanket multiplication, M | Minimum Q required | P_{fusion} , MW | |
| Transuranics, M=19 | 1 | 200 | solid fuel, engineered or active safety |
| Minor actinides, M=38 to 150 | 0.1 to 0.5 0.2 av. | 25 to 100 50 av. | “ |
| Transuranics, Molten salt, M=13 | 1.5 | 280 | passive safety |
| Fuel producer | | | passive safety |
| Fission-suppressed, M=2.1, ^{233}U | 8 | 1600 | |
| Fast-fission, M=10, ^{239}Pu | 2 | 370 | engineered safety |
| Power producer | | | molten salt passive safety solid fuel engineered safety |
| M=10 | 2 | 370 | |
| Pure fusion | | | passive safety |
| M=1.34 | 11 | 2300 | |

The condition of recirculating power fraction no more than 20% is restrictive resulting in the require Q values given above. If the recirculating power fraction could be allowed as high as 40%, the required Q values given above would drop approximately in half. A more detailed economic model that fully includes the value of the dual product of both electricity and fuel production or waste burning might result in a higher value of the combined products and therefore a lower required Q. Such a model would include the fleet of fission reactors whose fuel is supplied by the hybrid or the fleet of fission reactors whose wastes are incinerated by fissioning in the hybrid.

The fusion performance measured by Q for various operating modes of the mirror confinement is shown in Fig. 10. Also shown is the minimum Q required for the various hybrid applications from Table 3.

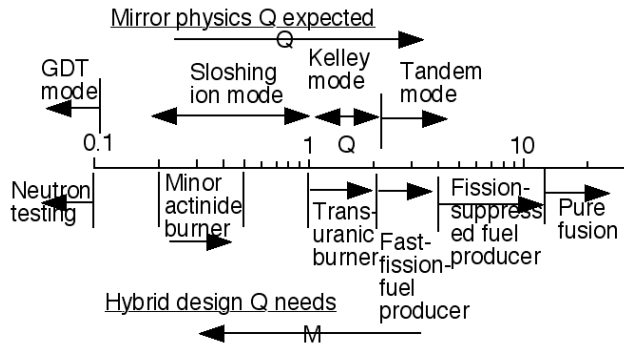

Fig. 10. Hybrid options and corresponding mirror operating regimes to obtain the required Q .

VIII. CONCLUSIONS

A fusion neutron source can be based on an all axisymmetric set of magnet employing existing neutral beams at 80 keV to achieve plasma conditions modestly extended from those already achieved. The predicted Q of ~ 0.6 would be sufficient for applications to burn minor actinide wastes (elements beyond Pu) in the sloshing ion mode. The system would be steady state requiring neutral beam technology development to extend lifetime to about a year. The heat load is spread over as much area as needed in end tanks and therefore is within the state-of-the-art. Pumping would be by well know condensation pumping that would need to be made steady by proposed techniques of cycling a portion of the pumps for outgassing at any one time. The solenoidal magnets at 2.5 T are common and even the 15 T mirror magnets are similar to those tested for ITER. With tandem mirror end cells added in the Kelley mode, the Q might be raised to about 1 to permit burning all actinides or in the tandem mode to >4 to allow fuel production in the fission suppressed mode. Fusion applications such as a materials-testing neutron source and other fusion technology will likely be developed independently and can be used by this hybrid application.

IX. ACKNOWLEDGMENTS

The authors are grateful to Curt Bolton for valuable discussions and encouragement. Work performed under the auspices of the U.S. Department of Energy, Oak Ridge Associated Universities, the University of California, Berkeley, and by Lawrence Livermore National Laboratory under Contract DE-AC52-07NA27344.

X. REFERENCES

1. A. A. IVANOV, A. D. BEKLEMISHEV, E. P. KRUGLYAKOV, P. A. BAGRYANSKY, A. A.

- LIZUNOV, V. V. MAXIMOV, S. B. MURAKHTIN, V. V. PRIKHODKO, "Results of Recent experiments on GDT Device after upgrade of heating neutral beams," *Fusion Sci. Technol.*, **57**, 320-325 (2010).
2. M.N. ROSENBLUTH, C.L. LONGMIRE, "Stability of plasmas confined by magnetic fields." *Annals of Physics*, **1**, 120 (1957).
3. P.A. BAGRYANSKY, A.A. LIZUNOV, A.A. ZUEV, E. YU. KOLESNIKOV, A.L. SOLOMACHIN. "Experiments with Controllable Application of Radial Electrostatic Fields in GDT Central Cell." *Fusion Sci. and Technology* **43**, 152 (2003)
4. P.A. BAGRYANSKY, A.D. BEKLEMISHEV, E.I. SOLDATKINA. "Influence of radial electric field on high-beta plasma confinement in the Gas-Dynamic Trap." *Fusion Sci. Technol.* **51**, 340 (2007).
- 5 D.D. RYUTOV. "Mirror type neutron source," *Plasma Physics and Contr. Fusion*, **32**, 999 (1990).
6. L. M. LIDSKY, "Fission-fusion systems: hybrid, symbiotic and augean", *Nuclear Fusion* **15**, 151-173 (1975).
7. D.D. RYUTOV, A.W. MOLVIK, T.C. SIMONEN. "Axisymmetric Mirror as a Driver for a Fusion-Fission Hybrid: Physics Issues," *J. Fusion Energy*, **29** (2010).
8. J. FREIDBERG, P. FINCK, C. BOLTON, Eds. Report "Research Needs for Fusion-Fission Hybrid Systems," Report of the Research Needs Workshop) ReNeW) Gaithersburg, Maryland Sept 30-Oct 2, 2009. MIT, January 2010.
9. R. W. MOIR, N. N. MARTOVETSKY, A. W. MOLVIK, D. D. RYUTOV, T. C. SIMONEN, "Axisymmetric Magnetic Mirror Fusion-Fission Hybrid," LLNL-TR-484071 (2011).
10. T.C. SIMONEN, S.L. ALLEN, T.A. CASPER, et al., "Operation of the tandem-mirror plasma-experiment with skew neutral-beam injection," *Phys. Rev. Lett.* **50**, 1668 (1983).
11. A. W. MOLVIK, "Impurity radiation from a beam-plasma neutron source," *Nuclear Fusion* **35**, 1247 (1995).
12. A. HERVE, "The CMS detector magnet", *IEEE Trans. Appl. Supercon.*, vol 10, No. 1, pp. 389-394, 2000.
13. Design Description Document: DDD 11 ITER_D_2NBKXY v1.2 Magnets 7. Conductors 09 September 2009.
14. N. MARTOVETSKY, J. MINERVINI, A. RADOVINSKY ET AL., "Test of the ITER Central Solenoid Model Coil and CS Insert", *IEEE Transactions on Applied. Superconductivity* v.12, N 1 March 2002, p. 600-605.

15. R.S. WILLMS, K. KOBAYASHI, Y. IWAI, T. HAYASHI, S. O'HIRA, M. NISHI, D. HYATT AND R.V. CARLSON; "Behavior of tritium in the TSTA test cell combined with operation of the Experimental Tritium Cleanup (ETC) system"; *Fusion Engineering and Design*, 61-62, 575 - 583 (2002).
16. R. HAZELTINE, ET AL., "Research Needs for Magnetic Fusion Energy Sciences," Report of Research Needs Workshop;
http://fire.pppl.gov/renew_final_report_2009.pdf
17. M. C. VELLA, W. S. COOPER, P. A. PINCOSY, R. V. PYLE, P. D. WEBER, and R. P. WELLS, "Development testing of the U.S. common long pulse source at 120 keV," *Rev. Sci. Instrum.* **59**, 2357 (1988).
18. J. KIM, R. W. CALLIS, A. P. COLLERAINE, ET AL., "Performance of the DIII-D neutral beam injection system," *Proc. 12th Symposium on fusion engineering, IEEE* (1987), p. 290.
19. T. STEVENSON, K. SILBER, L. LAGIN, ET AL., "The TFTR Neutral Beam Performance Database," *Fusion Technology* **21**, 1644, Part 2A (1992).
20. W. L. BARR, R. W. MOIR, G. W. HAMILTON, "Experimental results from a beam direct converter at 100 kV," *J. of Fusion Energy* **2**, 131 (1982).
21. E. R. HODGSON, "Challenges for insulating materials in fusion applications," *Nuclear Instrum. And Methods in Physics Research B* **191**, 744 (2002).
22. S. J. ZINKLE, V. A. SKURATOV, AND D. T. HOELZER, "On the conflicting roles of ionizing radiation in ceramics," *Nuclear Instrum. and Methods in Physics Research B* **191**, 758 (2002).
23. M. DECRETON, T. SHIKAMA, E. HODGSON, "Performance of functional materials and components in a fusion reactor: the issue of radiation effects in ceramics and glass materials for diagnostics," *J. Nuclear Materials* **329-333**, 125 (2004).
24. A. W. MOLVIK, R. H. MUNGER, T. J. DUFFY, and D. L. CORRELL, "Geometrically focused neutral beam accelerators," *Rev. Sci. Instrum.* **52**, 965 (1981).
25. A. W. MOLVIK, "Testing of Developmental Neutral Beam Sources for MFTF," *Proceedings of the 8th Symposium on Engineering Problems of Fusion Research, (IEEE)* p661 (1979).
26. R. W. Moir, et al., "Design of a Helium-Cooled Molten Salt Fusion Breeder", *Fusion Technology*, **8**, 1985, 465-473.
27. R. W. MOIR, ET AL., "Feasibility Study of a Fission-Suppressed Tokamak Fusion Breeder", Lawrence Livermore National Laboratory, Livermore, CA, UCID-20154 (1984).
28. W.M. STACEY ET AL., "A TRU-Zr metal-fuel sodium-cooled fast subcritical advanced burner reactor," *Nuclear Technology*, 162, 53, 2008.
29. M. KOTSCHENREUTHER, P.M. VALANJU, S.M. MAHAJAN, E.A. SCHNEIDER, "Fusion-Fission Transmutation Scheme-Efficient Destruction of Nuclear Waste." *Fusion Engineering and Design* 84 (2009) 83-88.
30. E. T. CHENG, "Performance characteristics of actinide-burning fusion power plants," *Fusion Science & Technology*, **47**, 1219-1223 (2005).
31. R. F. Post, "Mirror-based fusion: some possible new directions," *Trans. Fusion Sci. Technol.*, **35**, #1T, 40 (1999).
32. R.F. Post, "Magnetohydrodynamic stabilization of axisymmetric mirror systems using pulsed ECRH," *Fusion Sci. Technol.*, **57**, 335 (2010).