

Droplet Formation with Electromagnetic Pulse Force

V. Bojarevics, K. Pericleous

Abstract

Methods for serial generation of droplets from a liquid jet are shortly reviewed. A method of liquid metal droplet generation based on AC high frequency magnetic field is considered in detail. Numerical model for direct simulation of the time dependent droplet generation process is presented. Computed examples demonstrate the liquid silicon droplet formation for the cases of 500-1500 μm diameter.

Introduction

Micro droplet serial production is based on capillary break-up of liquid cylindrical jet. The initial theories describing the process were developed in 19th century by Rayleigh. The surface tension induced break-up can start, in principle, if the perturbation wave-length exceeds the circumference:

$$\lambda = \pi D, \quad (1)$$

where D is the liquid cylinder diameter. The fastest growing instabilities for the inviscid cylinder are axisymmetric ‘varicose’ type of the wave length $\lambda = 4.51 D$. Viscosity μ increases the critical wave length [1]:

$$\lambda = \sqrt{2}\pi D \sqrt{1 + \frac{3\mu}{\sqrt{\rho\sigma D}}}, \quad (2)$$

but the density ρ and the surface tension σ act to reduce the critical wave length for a simple cylindrical jet of infinite length.

In practical applications the liquid jet is of finite length, often contaminated by surface active elements (oxide films) and sensitive to external perturbations. Various successful practical applications of the liquid metal droplet generation are described in [2]. The most often used method for the droplet creation is by acoustic pressure perturbation of the jet at the outflow container. The falling droplets can be charged electrically to deflect their trajectories and to create desired deposition patterns. Alternatively the deposition substrate can be moved in an intricate manner, and used for the net-form manufacturing of complex 3-dimensional objects.

The drawbacks of the acoustic generation method are the need for strictly controlled atmosphere, pressure and metal cleanliness. The corrosion of the container and erosion of the nozzle (usually made of precious materials of typical orifice 0.1 – 0.3 mm) is precluding use of aggressive, refractory requiring liquid melts like aluminium, titanium, silicon etc. Therefore noncontact magnetohydrodynamic (MHD) methods are a viable alternative for the droplet creation. Various MHD interaction methods are described in the book by Kolesnichenko et al.

[3]. These methods are applied to various metals of moderate melting temperature. The droplet shape uniformity is very sensitive to various factors and the corrosiveness of the vessel and the nozzle material are posing significant problems.

For the purpose of reactive high melting temperature metal powder creation similar MHD methods are proposed in combination with the high velocity inert gas streams [4]. The droplets produced with these techniques are of highly non-uniform shape. Another useful idea is expressed in [5]: the nozzle clogging can be significantly reduced or even eliminated by applying electromagnetic stirring to the metal at the nozzle.

Numerical modelling of the fluid dynamics of droplet formation is usually restricted to relatively low velocities and including an encapsulating fluid in order to reduce value of the interaction parameters, see for example [6]. In the present work we attempt to model with the dynamic pseudo-spectral method the surface tension controlled electrically conducting droplet detachment process, initiated by the very high frequency AC magnetic field.

1. Numerical model

The numerical model is axisymmetric which permits accurate and fast calculation of the electromagnetic force at each time step during the full droplet formation and detachment cycle of the melt shape variation. The AC electromagnetic field in the axisymmetric situation can be described by introducing the magnetic vector potential \mathbf{A} related to the magnetic field $\mathbf{B} = \nabla \times \mathbf{A}$. Then the electric current is given as

$$\mathbf{J} = -\sigma \partial_t \mathbf{A} - \sigma \nabla \varphi = -i\sigma\omega \mathbf{A} + \mathbf{J}_s, \quad (3)$$

assuming that all functions can be expressed by means of complex exponents for the time dependence: $Q(x,t) = \text{Re}[Q(x)e^{i\omega t}]$, and the potential φ difference is imposed by the external power source to the coaxial coil carrying a given AC electric current \mathbf{J}_s surrounding the metal charge. The equation for the vector potential follows from the Ampere law for magnetically homogenous media

$$\nabla \times \mathbf{B} / \mu_0 = \mathbf{J}, \quad \nabla^2 \mathbf{A} = \mu_0 (\mathbf{J}_s - i\sigma\omega \mathbf{A}), \quad (4)$$

which can be solved by dividing the conducting region in finite cross-section rings according to the prescribed grid - the same grid as used for the solution of the fluid dynamic equations, which ensures a high resolution within the external boundary layer because of the dense Chebyshev grid used by the spectral representation of the fluid dynamic equations in this region [7].

The details of fluid dynamic numerical simulation technique are described in publications [7,8]. The shape and position of the liquid metal depend on the instantaneous balance of forces acting on it. Hence, the electromagnetic field and the associated force field are strongly coupled to the free surface dynamics of the liquid metal, the turbulent fluid flow within it and the heat transfer. This dynamic coupling of fields that are traditionally solved using different numerical methods poses a considerable modeling challenge, which has been addressed here using a unique spectral-collocation approach.

The present modelling approach is based on the turbulent momentum and heat transfer equations for an incompressible fluid:

$$\partial_t \mathbf{v} + (\mathbf{v} \cdot \nabla) \mathbf{v} = -\rho^{-1} \nabla p + \nabla \cdot (\nu_e (\nabla \mathbf{v} + \nabla \mathbf{v}^T)) + \rho^{-1} \mathbf{f} + \mathbf{g}, \quad (5)$$

$$\nabla \cdot \mathbf{v} = 0, \quad (6)$$

$$C_p(\partial_t T + \mathbf{v} \cdot \nabla T) = \nabla \cdot (C_p \alpha_e \nabla T) + \rho^{-1} |\mathbf{J}|^2 / \sigma , \quad (7)$$

where \mathbf{v} is the velocity vector, p - the pressure, ρ - the density, $\nu_e = \nu_T + \nu$ (summ of turbulent and laminar viscosity) is the effective viscosity which is variable in time and position, \mathbf{f} is the electromagnetic force, \mathbf{g} - the gravity vector, T - the temperature, $\alpha_e = \alpha_T + \alpha$ (summ of turbulent and laminar) is the effective thermal diffusivity, C_p - the specific heat, and $|\mathbf{J}|^2 / \sigma$ is the Joule heat.

The general conditions at the external free surface boundary are stated for the hydrodynamic stress tensor Π component projections on the surface at each time moment. The normal stress component is compensated by the surface tension and the tangential stress component is zero:

$$\Pi_{nn} = \gamma K , \quad \Pi_{n\tau} = 0 , \quad (8)$$

where γ is the surface tension coefficient, K - the mean curvature of the surface, and the subscripts correspond to projections onto \mathbf{e}_n and \mathbf{e}_τ - the normal and tangent unit vectors at the free surface. In addition to the dynamic conditions (8), the kinematic condition states that the calculated material fluid velocity \mathbf{v} moves continuously with the interface position $\mathbf{R} = \mathbf{e}_R R(t)$:

$$\mathbf{e}_n \cdot \mathbf{v} = \mathbf{e}_n \cdot \partial_t \mathbf{R} . \quad (9)$$

The boundary condition for the thermal losses is pure radiation:

$$-\rho C_p \alpha_e \mathbf{e}_n \cdot \nabla T = \varepsilon \sigma_B (T^4 - T_0^4) , \quad (10)$$

where ε is the emissivity constant for a particular material, σ_B is Boltzman constant, and T_0 is the environment temperature. The conditions at the jet influx are the given melt temperature, pressure at the bottom of the holding vessel, and the Poiseuille velocity profile.

2. Droplet generation simulation

Let us consider first the liquid silicon (Si) jet emanating from the nozzle of diameter 0.5 mm without any electromagnetic interference. As can be seen in Fig. 1, the detachment at its initial stage is predicted when the capillary instability sets in, however the exit velocity is kept rather low and the process takes rather long time of approximately 0.00720 s. The exit velocity is controlled by the pressure at the nozzle which results from the liquid level and, possibly, imposed excess pressure in the container above the nozzle exit. In the case of Fig. 1 the pressure corresponds to 15 cm level of liquid Si in the container, and the resulting exit velocity is variable during the process, on average 0.6 – 1.0 m/s.

When the pressure at the nozzle is increased, corresponding to 20 cm of liquid Si in the container (exit velocity 1 – 1.4 m/s), the droplet detachment is not achievable any more, because the flow dynamically moves the constriction downstream, and a continuous jet is created. The same occurs for even higher pressure and the correspondingly higher exit velocities.

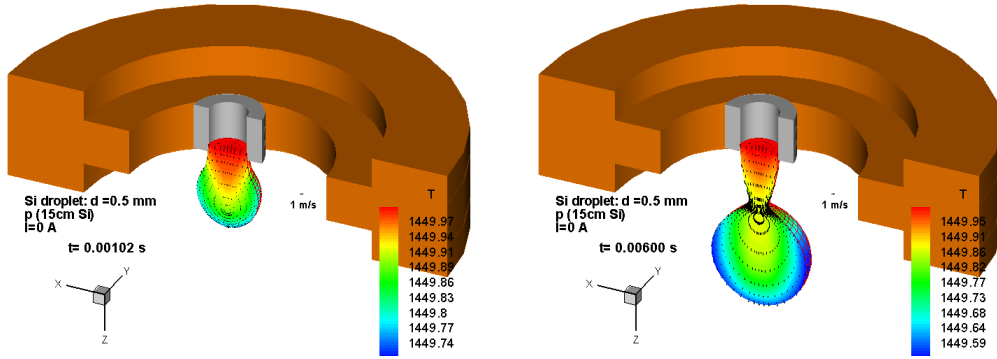

Fig. 1. 0.5mm diameter Si droplet detachment at lower exit velocities, $I = 0$ A.

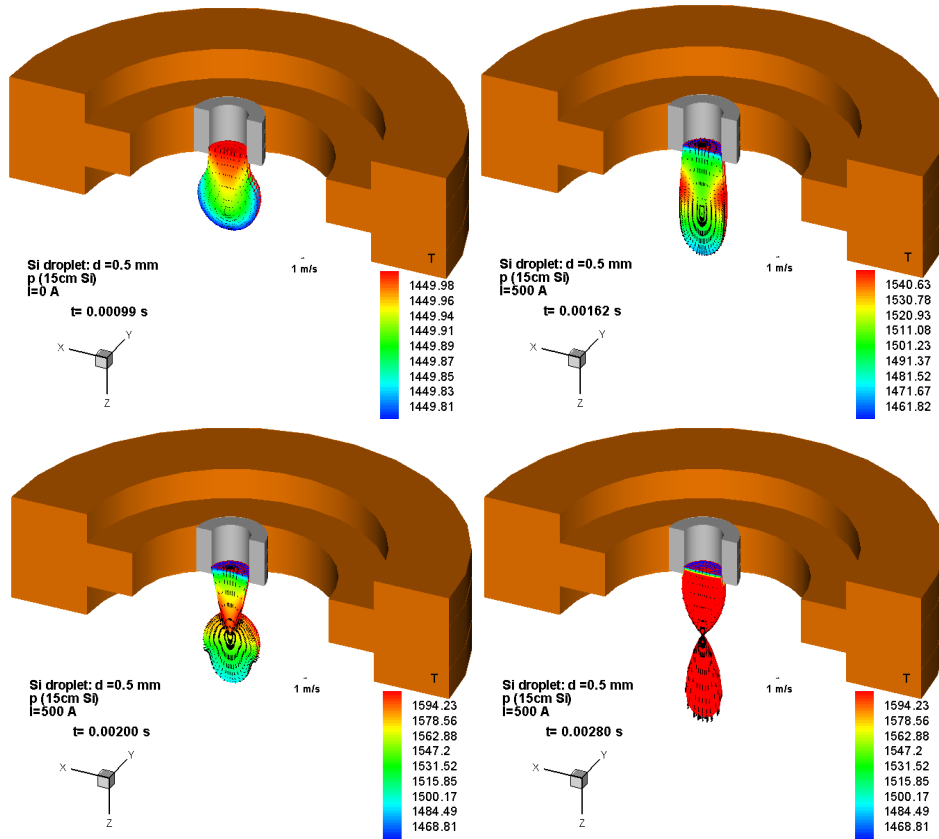

Fig. 2. Magnetically perturbed 0.5mm diameter Si droplet detachment, $I = 500$ A.

A series of numerical experiments with the varying coil geometry and the current magnitudes showed that a single turn coil is sufficient and optimal for the droplet detachment process. Fig. 2 demonstrates how the droplet detachment process can be made controllable and much faster with the electromagnetic induction interaction. Still the main physical mechanism for the droplet detachment is the capillary instability, which however is triggered by the compressing electromagnetic force created at a small, limited time interval of about 0.001 s. The full droplet detachment cycle lasts about 0.003 s, during which an individual droplet of about 0.5 mm diameter can be created. This process can be classified as a ‘droplet on demand’, and can be used at arbitrary intervals or at continuous rate.

Fig. 3 shows the electromagnetic force and the induced electric current distribution in the droplet during the short electromagnetic force impulse. The force is rather distributed along the surface of the liquid and does not lead to a local constriction. The force is more effective with the higher frequencies.

It is easier to create local constriction of the out-coming jet for a nozzle of larger diameter. The detachment process for 1.5 mm diameter nozzle is illustrated in Fig. 4. In order to maintain the sufficiently high exit velocity, the pressure at nozzle was corresponding to 20 cm level of the liquid in container. The velocity of about 1 m/s is computed at the nozzle. The induced force effectively blocks the outflow from the nozzle by creating the oppositely driven mass flow for a short time, similarly to the acoustic pressure modulation, in this case however created by the action of the rotational electromagnetic force. The capillary forces are responsible for the final fast detachment instability, triggered by the electromagnetic ‘constriction’ and the short flow ‘blockage’ at the nozzle. Considerable heating occurs at the jet exit during the very short time while the electric current is imposed. The temperature increases by approximately 70 -100 degrees locally at the nozzle, which could be beneficial to prevent nozzle clogging and melting the solidified metal after the process interruption.

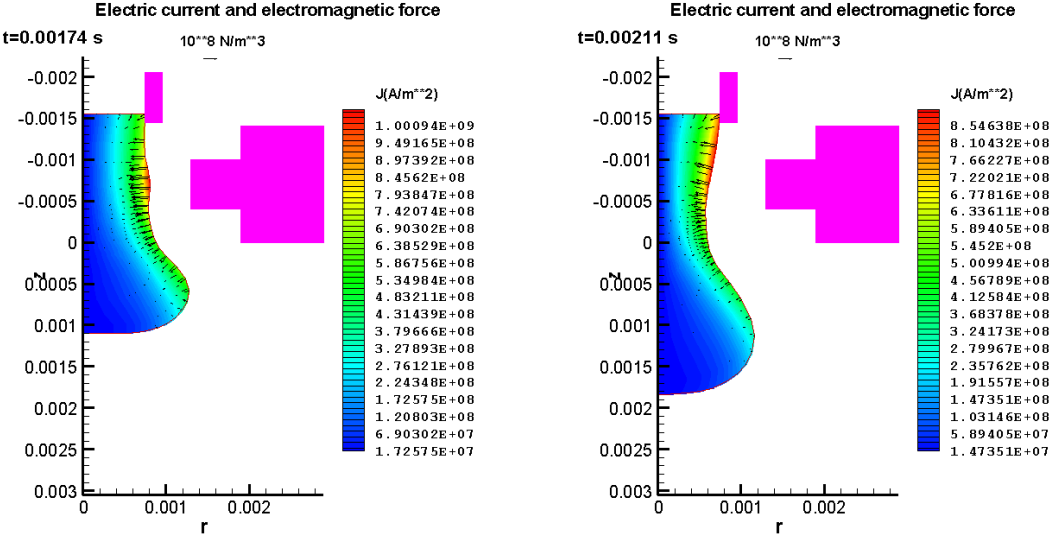

Fig. 3. Electromagnetic force induced in the 1.5 mm diameter Si droplet, $I = 400$ A.

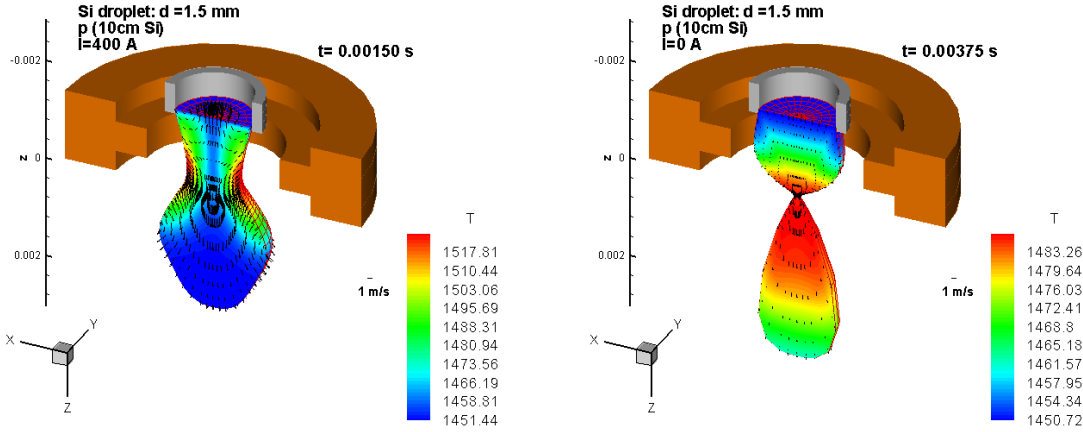

Fig. 4. 1.5 mm diameter Si droplet detachment at low exit velocity, $I = 400$ A.

At lower exit velocities, corresponding to 10 cm of liquid level in the container, and without the electromagnetic interaction, the thicker jet of 1.5 mm nozzle exit fails to detach, similarly

to the narrow nozzle (0.5 mm) case. But with the electromagnetic impulse the droplet readily detaches, producing a rather small size droplet at the end of cycle.

Most of the detached droplets in the described numerical experiments, similar to those observed in experiments [3], are quite elongated in shape after the detachment. Our simulations demonstrate also the fast constriction of the droplet by surface tension forces and the inertial oscillations arising. The larger the viscosity, the faster the oscillation damping, as it is confirmed by our numerical experiments. If the fluid temperature approaches the mushy zone temperature interval, then the oscillations are immediately damped. The preexisting turbulence in the jet, created at the container exit and by the electromagnetic stirring, is favorable to damp the oscillations because the effective turbulent viscosity is much higher than the laminar.

3. Conclusions

1. The dynamic spectral simulation method permits to detect the capillary instability development for the short liquid metal jet from a nozzle.
2. The optimum electromagnetic interaction to initiate the droplet detachment is limited in time and depends on the critical AC field magnitude.
3. Larger diameter nozzle is preferable for the more efficient electromagnetic interaction.
4. Nozzle can be maintained clean from impurities and the metal can be remelted if the metal solidifies in the nozzle.

References

- [1] S.Chandrasekhar. *Hydrodynamic and Hydromagnetic Stability*. 1961, Dover, New York, p. 537-542.
- [2] M.Orme, A.Bright. *Recent advances in highly controlled molten metal droplet formation from capillary stream breakup*. In *Liquid Metal Atomization: Fundamentals and Practice*, eds. S.D.Ridder and F.S.Biancanillo, The Minerals, Metals & Materials Society, 2000, Warrendale, p. 157-168.
- [3] A.F.Kolesnichenko et al. *Capillary MHD Flows with free surface*. 1988, Kiev (Ukraine), Naukova Dumka. (In Russian).
- [4] R.Gerling, H.Clemens, F.P.Schimansky. *Powder metallurgical processing of intermetallic gamma titanium aluminides*. *Advanced Engineering Materials*, 2000, **6**, No. 1-2, p. 23-38.
- [5] J.D.Lavers, L.Kadar. *Application of electromagnetic forces to reduce tundish nozzle clogging*. *Applied Mathematical Modelling*, 2003, **28**, p. 29-45.
- [6] Y.Pan, K.Suga. *Capturing the pinch-off of liquid jets by the level set method*. *Journal of Fluids Engineering*, 2003, **125**, p.922-930.
- [7] V. Bojarevics, K. Pericleous. *Modelling Electromagnetically Levitated Liquid Droplet Oscillations*, *ISIJ International*, 2003, **43**, No. 6, p. 890-898.
- [8] Bojarevics V., Pericleous K., Harding R.A. and Wickins M. *The Development and Validation of a Numerical Model of an Induction Skull Melting Furnace*. *Metall. Materials Tran. B*, 2004, **35**, p.785-803.

Authors

Dr. Bojarevics, Valdis
Prof. Pericleous, Koulis
School of Computing and Mathematical Sciences
University of Greenwich
Park Row
London, SE10 9LS, UK
E-mail: v.bojarevics@gre.ac.uk