



INTERNATIONAL JOURNAL OF ADVANCE RESEARCH, IDEAS AND INNOVATIONS IN TECHNOLOGY

ISSN: 2454-132X

Impact factor: 4.295

(Volume3, Issue2)

Smart RTO System (SRS)

Avanish Mishra¹

Computer Department ,
Yadavrao Tasgaonkar Collage of
Engineering and Technology, Chandhai,
India

Ashish Singh

Computer Department ,
Yadavrao Tasgaonkar Collage of
Engineering and Technology, Chandhai,
India

Rajeshwar Singh

Computer Department ,
Yadavrao Tasgaonkar Collage of
Engineering and Technology, Chandhai,
India

Abstract: This document describes the project of SMART RTO SYSTEM (SRS) it describes the development in technology. Saving time and making more efforts for Traffic Police. Our Objective is to provide the advance technology to Police officer. This document is all about the system used for traffic challan. It consists of interfacing of printer and Smart card reader to Android phone. The data will be stored in Main server. All the functions will be made according to the Indian Penal Code Sections. The machine will be connected to the server. The penal code will be entered by traffic police officer and it will print the challan with IPC section code and amount of penalty.

Keywords: RTO, Microprocessor, IPC.

INTRODUCTION

The SMART RTO SYSTEM is a basic need in now-a-days developing technology.

- By using this software one can easily manage all the jobs
- Prof. Nilima Nikam² Professor at Department of Computer Engineering from Yadavrao Tasgaonkar Institute of Engineering and Technology, Bhivpuri road, Chandhai, Karjat
- Which is difficult to sort by RTO.
- This project should reflect majority program outcomes as achieved by the officers.
- Through the new system, the Traffic police will create a centralised data bank of all vehicles, details of their registered owners and driving licences. The traffic cops on beat duty will be provided with smart phone with a special Android software.

1.1 About License

Now days the license has transformed into smart card. The smart card can be classified by its chip type:

1. Memory: It simply store data like floppy disk with poor security.
2. Microprocessor card: It can add, delete, update and manipulate the data.

In license card Contact cards are inserted for read-write operations. They have small gold plate about 1/2" diameter known as micro module. When card is inserted into Smart card reader, the data is transferred to and from.

1.2 About machine

This machine consists following hardware:

- Smart Card Reader
- Android phone
- Mini printer
- Hc05

Literature Review

In this project we have made research over the working Traffic police. Whenever the driver violates any rule, it takes very long time to pay fine. It is also very difficult to verify the license that whether it is original or fake. Police needs to maintain all records manually. If officer needs the record of the driver coming for distant place, its takes long procedure and multiple of days.

Let's take the example, consider a driver who had parked his car at wrong place. Traffic police will make challan and take the documents of car. The person will have to pay fine immediately. The next day he has visit to court to confess whether driver had

made any mistake or not. If driver accept his mistakes then court refunds particular amount of fine. In all these procedures neither the court nor that officer aware of that person whether he had violated the same rule or not. By observing all these problems, we have introduced a new system which helps to overcome with these problems. This device will be assign to every Traffic officer so that they can make challan through this device. All the data of driver will be stored in the main server, which helps to retrieve the data of any driver at any corner of location.

This device also keeps the location of person where challan had made. So that he can visit to nearest court of that location.

Problem Definition and Scope

- Now-a-days it is very difficult to update all the data of challans in database
- Each entry is done manually.
- It is very difficult for officers to verify for correct license holders on road.
- To overcome these problems Smart RTO System introduced.
- It is very easy to verify the license of the driver
- The data of individuals with the violated rules will be stored in database
- The same of number rules violated by same person will be noticed, so that violator have to more penalty according to court.
- It is very time efficient.
- It also saves the paper, because all the data are in digital format
- Since it is in digital format, it requires less physical space as compared to paper files and registers kept in office.
-

METHODOLOGY

This project is based on Android application
 There will be interfacing of hardware with android smart phone.

3.1 Working of project

- Officer will ask for license card to driver
- The licence will be scanned with the help of Smart Card reader
- Details of driver will be retrieved in app
- System will Verify for original license card
- The IPC code will be written according violation of rules
- If the violation of rule found repeated by same driver, then there will be more amount of penalties charged from user
- The record will be updated in the main server of government.

3.2 Block diagram of microcontroller

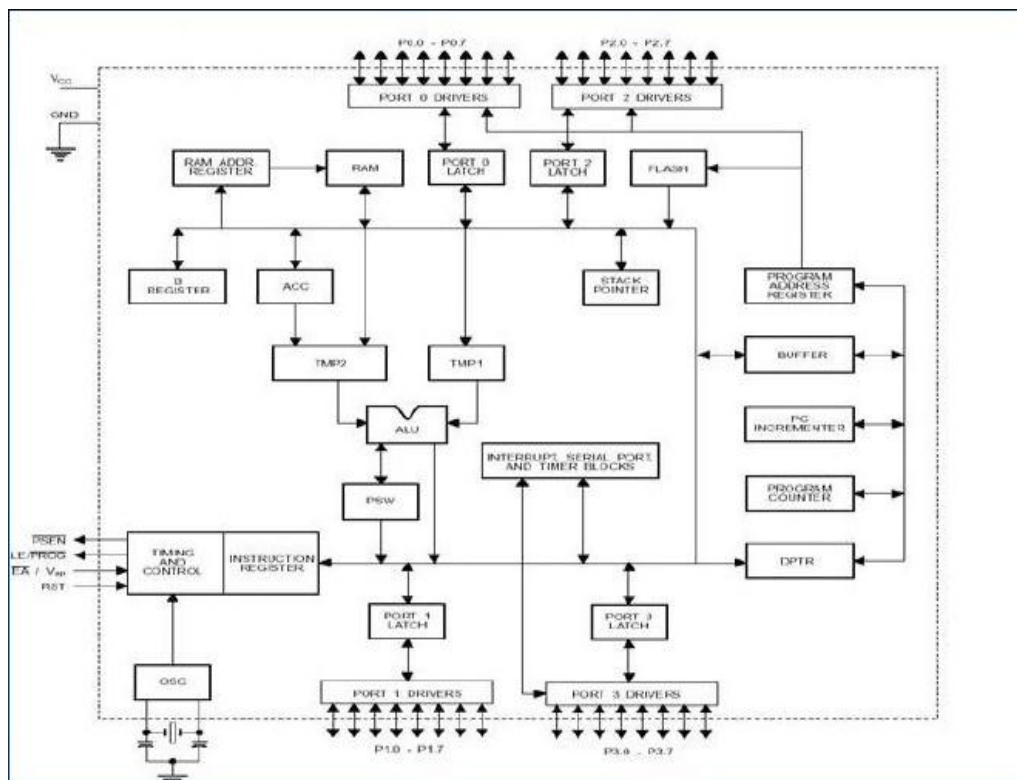

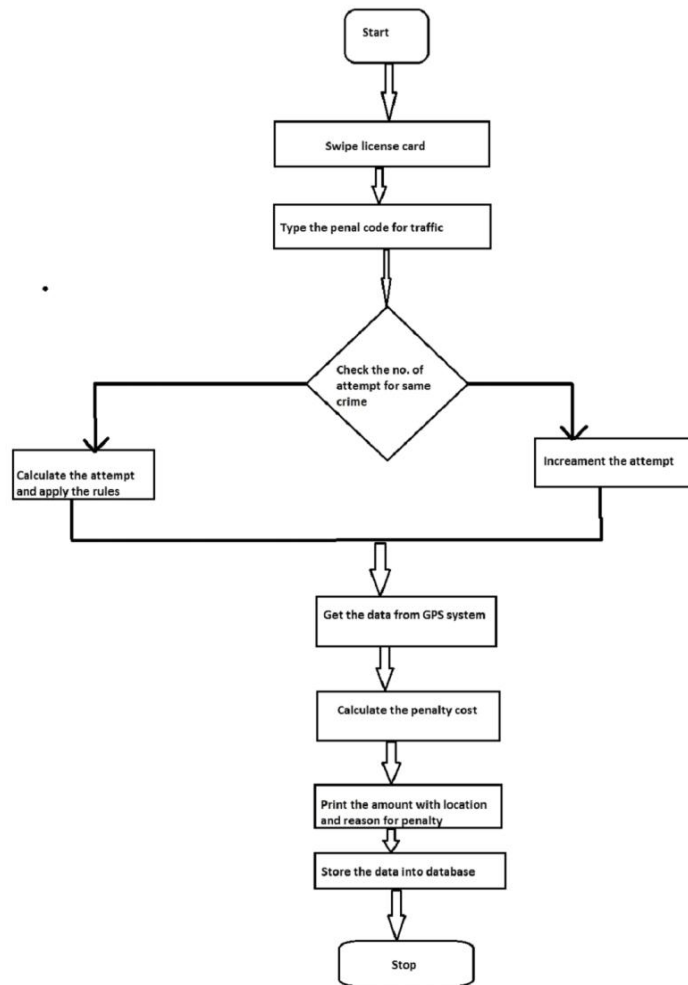

Flow chart for working of device (fig.b)

3.3 Language Used

Embedded C: This language is used for writing the code for chip level. It is also known as mixed language.

Java: This language is used for writing the code of android app. This is also most secure language.

ASP Dot Net using C#: This language is used for making web application.

Design

4.1 Data flow diagram

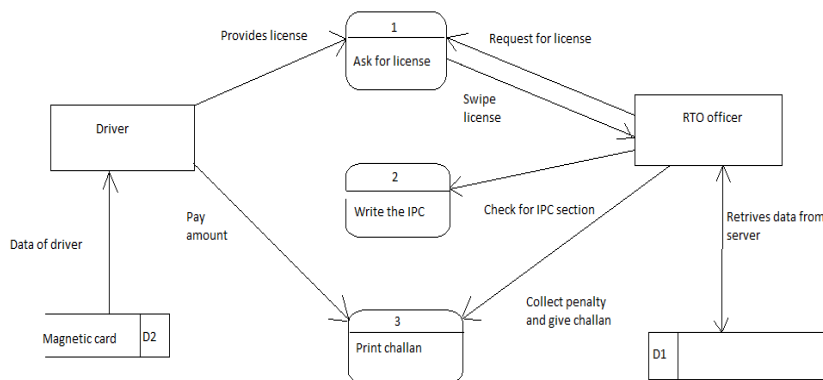

DFD level 0
DFD level 1

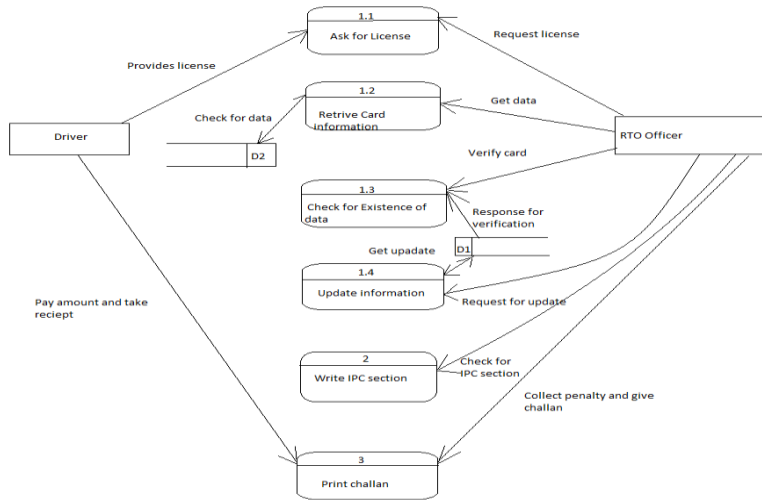

DFD level 2

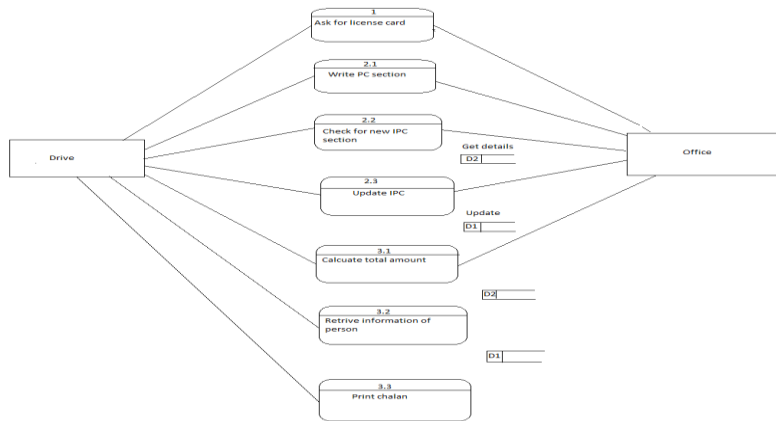

4.2 UML diagram
4.2.1 Sequence diagram

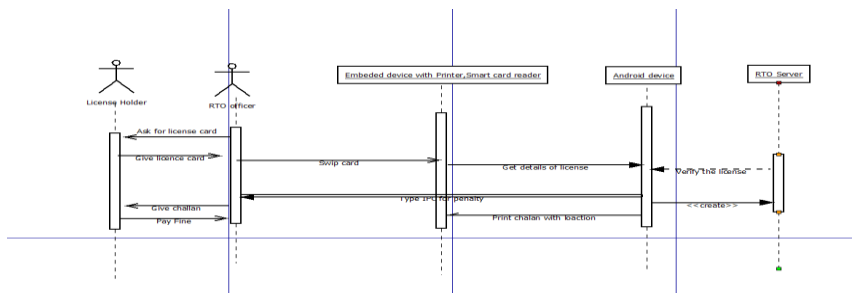

4.2.3 Use case Diagram

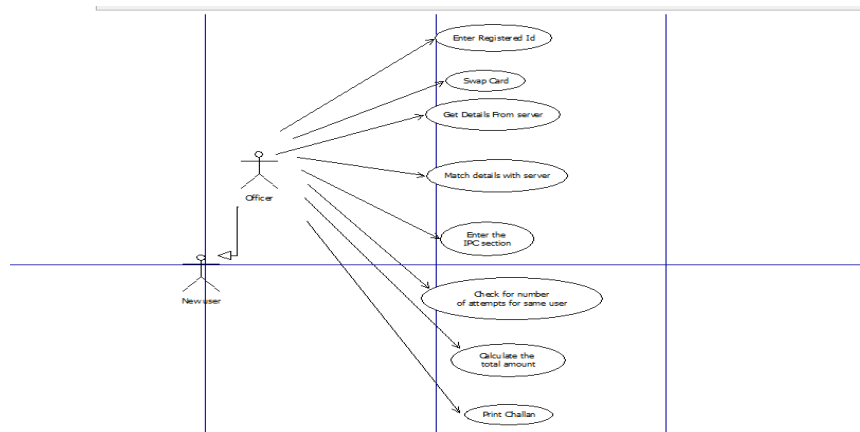

Software Requirement

5.1 For server

Visual studio:

It is a Microsoft product used as IDE for software and Web pages.

My SQL is needed for database.

5.2 System requirement

Minimum 4GB RAM

1 GHz Processor, Windows 7/8/8.1/10

5.3 KEIL

KEIL IDE is basically an assembler and a compiler. You can write either an Assembly or C language code and KEIL will take care of the rest for you. Furthermore, it supports many of the 8051 variants that you will face.

5.4 Android studio

Android Studio is the official integrated development environment (IDE) for Android platform development.

5.4.1 System requirements

Windows OS X Linux

OS version

Microsoft Windows 10/8.1/8/7/Vista/2003/XP (32 or 64 bit)

Mac OS X 10.8.5 or higher, up to 10.10 to up 10.10.2 up 10.10.3 or 10.10.5 (Yosemite)

GNOME or KDE or Unity desktop on Ubuntu or Fedora or GNU/Linux Debian RAM 2 GB RAM minimum, 4 GB RAM

recommended Disk space 500 MB disk space for Android SDK At least 1 GB for Android SDK, emulator system images, and caches JDK version Java Development Kit (JDK) 7 or higher Screen resolution 1280x800 minimum screen resolution.

Hardware requirement

6.1 Android phone:

- OS minimum 5.0,
- 512MB RAM

6.2 Blue-tooth module-JY MCU BT HC-06

The module provides a method to connect wirelessly with a PC or Bluetooth phone. Bluetooth module can be used in master slave configuration. The role of the module can be configured only by AT COMMAND. The user can use it simply to establish a connection to other device. In Bluetooth module hardware used as

- Up to +4dBm RF transmits the power.
- 3.3 to 5 V I/O.
- PIO (Programmable Input/ Output) control.
- UART interface with programmable baud rate.
- With integrated antenna.
- With edge connector

Software features

- Slave default Baud rate: 9600, Data bits: 8, Stop bit: 1, Parity: No parity.
- Auto-connect to the last device on power as default.
- Permit pairing device to connect as default.

- Auto-pairing PINCODE:”1234” as default.

6.3 Microcontroller

It consists of memory, peripheral device and I/O device used for embedded system

Block Diagram of ATMEL

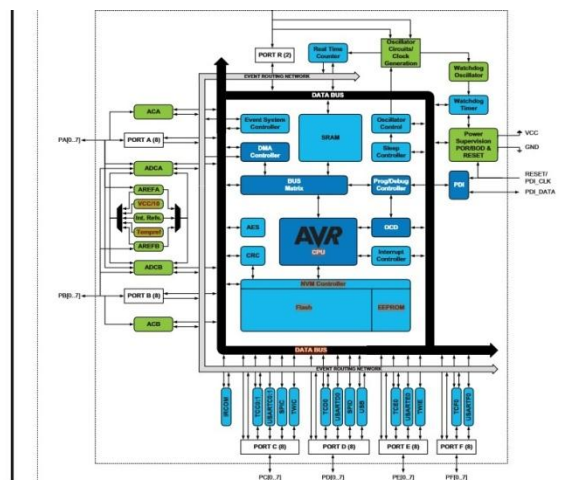

6.4 Smart Card Reader

There are two types of smart cards: contact and contactless. Both have an embedded microprocessor and memory.

The smart card differs from the proximity card in that the microchip and the proximity card has only one function: to provide the reader with the card's identification number.

The processor on the smart card has an embedded operating system and can handle multiple applications such as a cash card, a pre-paid membership card, or an access control card.

Since contact cards must be inserted into readers carefully in the proper orientation, the speed and convenience of such a transaction is not acceptable for most access control applications.

The difference between the two types of smart cards is the manner with which the microprocessor on the card communicates with the outside world. A contact smart card has eight contact points, which must physically touch the contacts on the reader to convey information between them.

The use of contact smart cards as physical access control is limited mostly to parking applications when payment data is stored in card memory, and when the speed of transactions is not as important.

Applications

- This device is used for RTO system.
- On road if driver forget his license, but if they know their license number they could easily safe from penalty.
- The data of all the licensed holder will be stored in the main server.
- This will reduce cost and space of the department.
- No, need for doing heavy file work, as all the records will be stored in digital format.
- Criminals from other states could be traced easily.
- Same numbers of violated rules by individual can be found easily.
- Officers can easily charge on one click instead of writing on paper.
- Details of crime will be stored automatically on database.
- No need of entering regular data of penalties manually.
- Fake license holder will be caught easily.
- It will be easy to determine the same number of penalties over individuals.
- People will aware of traffic rules and regulations.
- This reduces corruption.
- People will give fine for particular penalties, as the penalties are already assigned in machine.

CONCLUSION

This project is in development stage. The operating system of smart phone is Android which helps in interfacing with embedded system. This device uses either blue-tooth or USB 2.0 for interfacing between embedded hardware and smart phone. Through this project it will be great help for Police officers.

ACKNOWLEDGEMENT

I take the privilege to express my sincere thanks to **Dr. Rajendra Prasad, Principal of Y.T.I.E.T. Bhivpuri road** and **Prof. Vaishali Londhe Head Department Of Computer Engineering, Yadavrao Tasgaonkar Institute of Engineering and Technology** for providing the much needed support.

I wish to express my wholehearted appreciation and deep sense of heartfelt gratitude to my guide **Prof. Nilima Nikam, Professor, Department Of Computer Engineering** for generous help

Excellent guidance, lucid suggestions and encouragement throughout the course of this work. His concrete directions and critical views have greatly helped me in successful completion of this work.

I am also thankful to all those who directly or indirectly in completion of this work.

REFERENCES

1. <https://developer.android.com/guide/topics/>
2. <http://www.atmel.com/products/microcontrollers/default.aspx>
3. Embedded Systems Book by Raj kamal