



AENSI Journals

## Advances in Environmental Biology

Journal home page: <http://www.aensiweb.com/aeb.html>

## Development of Pilot Plant for Novel Geopolymer Brick Making Machine

<sup>1</sup>M.T. Muhammad Faheem, <sup>1</sup>A.M. Mustafa Al Bakri, <sup>1</sup>C.M. Ruzaidi, <sup>2</sup>M. Bnhussain, <sup>1</sup>H. Kamarudin, <sup>2</sup>S. Mohammad Tamizi, <sup>1</sup>A.M. Izzat and <sup>1</sup>A. Alida

<sup>1</sup>Center of Excellence Geopolymer & Green Technology (CEGeoGTech), School of Material Engineering, Universiti Malaysia Perlis (UniMAP), P. O. Box 77, d/a Pejabat Pos Besar, 01000 Kangar, Perlis Malaysia

<sup>2</sup>King Abdul Aziz City Science and Technology, P.O Box 6086, Riyadh 11442 Kingdom of Saudi Arabia

## ARTICLE INFO

**Article history:**

Received 11 September 2013

Received in revised form 21

November 2013

Accepted 25 November 2013

Available online 5 December 2013

**Key words:**

Geopolymer, Brick, Kaolin, Fly Ash, Boiler Ash, Alkaline Activator, Masonry Brick, Brick Making Machine

## ABSTRACT

With rapid growing country's development and rose in construction activity, rising demand of building materials and increased construction wastes have encouraged the development of new building materials. Geopolymer based construction materials such as concrete, aggregate, brick and so on are getting good response by the public especially those in the construction and development industries nowadays. Geopolymer bricks making process consume less energy and low cost in term of raw materials and production compared to conventional bricks. It become a necessity nowadays to provide a machine that produced construction material based on geopolymer that are compatible with geopolymer process that can improved productivity and promote geopolymer construction material to replace conventional construction material. This paper presents the main component, specification and controlling system of the geopolymer brick making machine. This paper also describes the basic operation of the brick produced by using novel geopolymer brick making machine. The capacity production is adequate which has mixing tank capacity of 40 kg per batch with high compaction pressure which is 40 tonne and low curing temperature needed (less than 100 °C) that can produce high quality and environmental friendly brick. The size of the brick produced is 9" x 4" x 2.5" accordance with the standard size based on British Standard BS 3921: 1985.

© 2013 AENSI Publisher All rights reserved.

To Cite This Article: M.T. Muhammad Faheem, A.M. Mustafa Al Bakri, C.M. Ruzaidi, M. Bnhussain, H. Kamarudin, S. Mohammad Tamizi, A.M. Izzat and A. Alida., Development of Pilot Plant for Novel Geopolymer Brick Making Machine. *Adv. Environ. Biol.*, 7(12), 3611-3616, 2013

## INTRODUCTION

The construction industry is important towards sustainable development. Sustainable construction can be achieved with the application of tools that deal with the assessment of the whole life cycle, site planning and organization, material selection, re-use and recycling of materials, waste and energy minimization. With the development of building construction activities all around the world, inadequacy of conventional building materials like bricks, cement, aggregates, and so on, have made development of new building materials very important with the aid of modern advanced technologies in the present competitive days of economic liberalization and globalization. The environmental issues are among reason that pressured the industries to provide a product and materials that are more environmental friendly. Ordinary Portland cement (OPC) which is a highly energy intense product that generate CO<sub>2</sub> is the binder used in the production of concrete used in nowadays [1]. It is commonly accepted that geopolymer binder is a potential material to be part of the solution due to its lower CO<sub>2</sub> emissions compared to OPC concrete [1]. There are a lot of studies that suggest the possibility of CO<sub>2</sub> mitigation in cement industry by implementing the advance technology in cement production technology [2, 3, 4]. This can possibly reduce the CO<sub>2</sub> emissions level.

J. Davidovits had been the first to developed and introduced geopolymer which is a type of three-dimensional CaO-free aluminosilicate binder, which was developed in the late 1970s [5]. Geopolymer is claimed to possess excellent mechanical performance with respect to high compressive strength, chemical resistant and fire resistant [6,7, 8].

**Corresponding Author:** M.T. Muhammad Faheem, Center of Excellence Geopolymer & Green Technology (CEGeoGTech), School of Material Engineering, Universiti Malaysia Perlis (UniMAP), P. O. Box 77, d/a Pejabat Pos Besar, 01000 Kangar, Perlis Malaysia.

Commercial bricks that usually used in construction are made from ordinary Portland cement (OPC) or clay with sand, which are mixed and molded in various ways and need to be dried or burned [9]. The conventional brick processing process is more complicated and take longer time. Geopolymer bricks are made with less energy and low cost than that needed in production of conventional bricks. The development of geopolymer brick is an important step towards produce bricks with better performance and environmental friendly material. However, studies on the brick produced using the geopolymer were still limited.

In this paper, we will be providing details of component and specification of geopolymer brick making machine. This paper also described the controlling system and basic operation in producing the geopolymer brick by using this novel geopolymer brick making machine.

#### *Main Component and Specifications:*

##### *Mixer:*

The structure of the mixer including mixing tank, spindle shaft, and body of mixer was made with mild steel structure coated with powder coating. The motor installed were spindle motor with 2 horse power helical gear. The speed of motor for mixing process was 10 rotations per minute that can be control with controlling board. The capacity of the mixing tank was 40 kg. The mixing will be transfer from the mixing tank to the moulding component by mini conveyor below the mixing tank. The speed of the mini conveyor can be control with speed controller at the conveyor. The schematic of mixer can be seen in Figure 1 below.

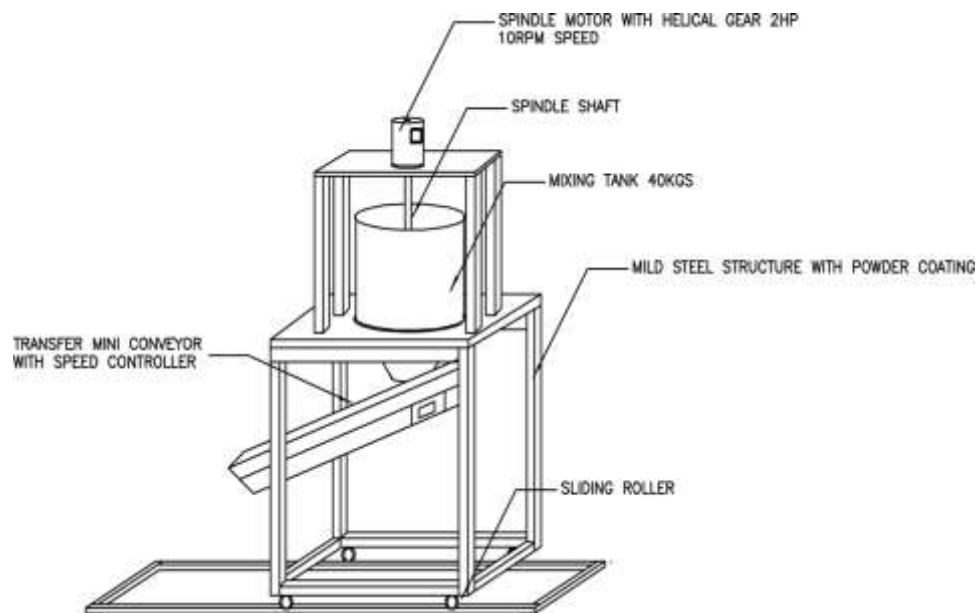

**Fig. 1:** Schematic Diagram of Mixer.

##### *Moulding and compactor:*

Figure 2 shows the schematic diagram of moulding and compactor part of geopolymer brick making machine. The main component of compactor is air cylinder pressing with force capacity of 40 tonne. The size of the mould is 9" x 4" x 2.5" accordance with the standard size based on British Standard BS 3921: 1985 [10]. There are three plates in the moulding and compactor. The first plate is top support plate made with 12 mm steel plate to support the air cylinder presser. Then 12 mm steel pressing plate that hold the top pressing plate and bottom base plate connected with mould made with 15 mm steel plate.

##### *Extension conveyor:*

Extension conveyor function is to transfer the brick specimen after mould and compacted from moulding and compactor part to curing conveyor oven. As shown in Figure 3, the conveyor belt was made with nylon with aluminum profile frame. The speed of the conveyor can be controlled with conveyor speed controller at maximum speed of 200 mm per second. The stand leveling is adjustable and heavy duty.

##### *Curing conveyor oven:*

Figure 4 shows the schematic diagram of curing conveyor oven part of geopolymer brick making machine. The curing process of geopolymer brick is different than conventional concrete brick where it needs to be cured with heat. For the clay brick, the curing process is divided into two where the brick need to be dried first for 4 to 5

days in order to dry before the brick is baked with high temperature around 980 to 1030 °C for 100 to 130 minutes [11]. Geopolymer brick only need to be heated with low temperature less than 100 °C for 20 to 30 minutes depending on the material and design ratio [12, 13, 14]. The operating temperature capacity for the oven is between 50 °C to 500 °C. The temperature can be adjusted depending on the geopolymer used to produce geopolymer brick. The oven use infrared as the heating element with fiber wool insulated cover. The heating time used for one brick specimen can be adjusted by adjusting the speed of the conveyor. For the conveyor, stainless steel belt was used in this machine.

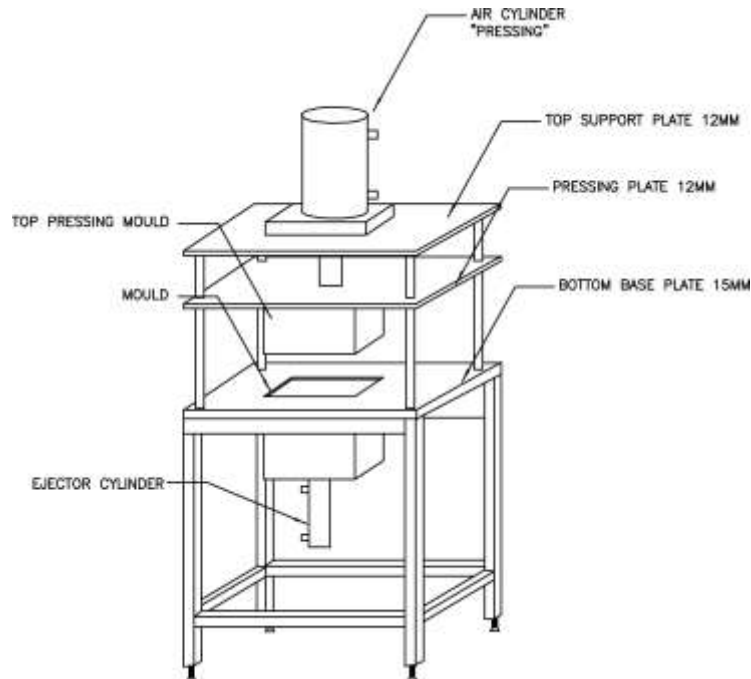

**Fig. 2:** Schematic Diagram of Moulding and Compactor.

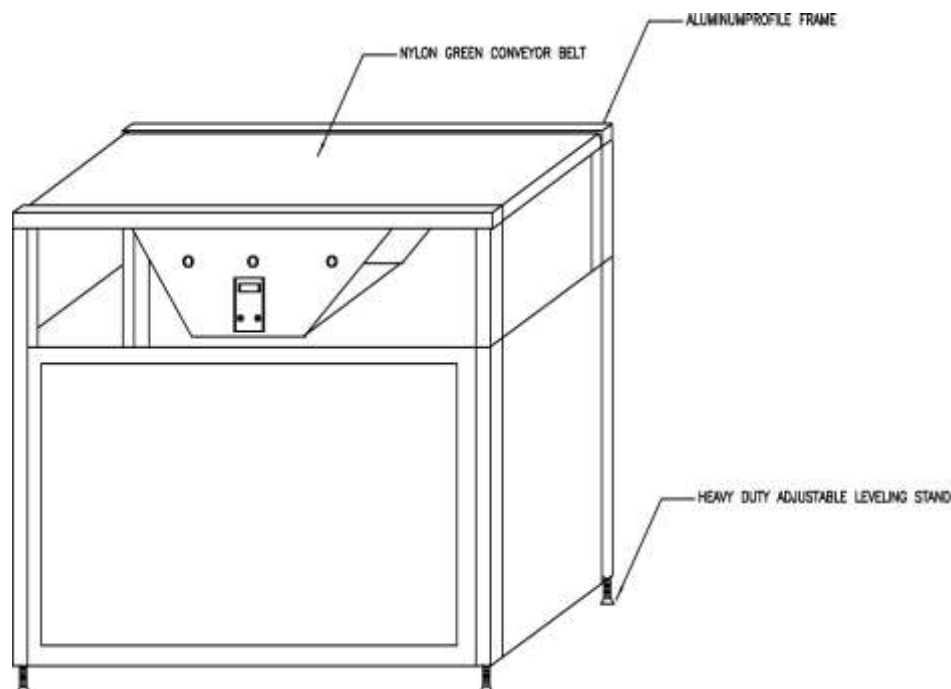

**Fig. 3:** Schematic Diagram of Extension Conveyor.

*End gravity conveyor:*

The component of end gravity conveyor made with from steel coated with powder coating. At the bottom of the end gravity conveyor, a heavy duty adjustable leveling stand was installed as in Figure 5. The purpose of this part of geopolymer brick making machine is to roll the end product of brick specimen to be use.

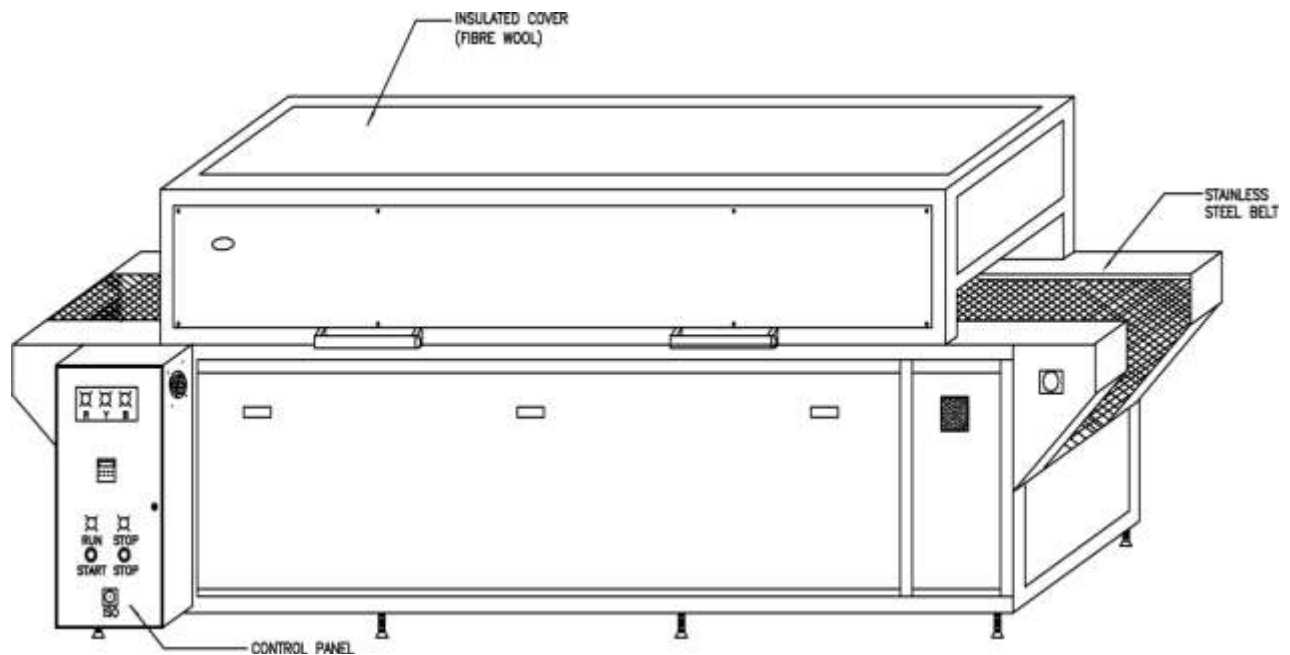

**Fig. 4:** Schematic Diagram of Curing Conveyor Oven.

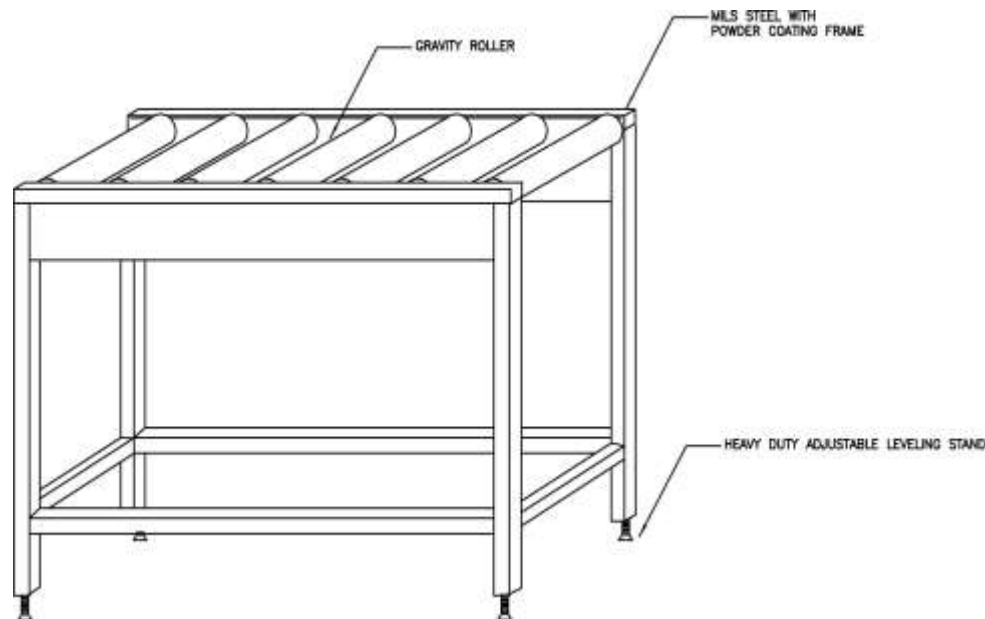

**Fig. 5:** Schematic Diagram of End Gravity Conveyor.

*Control Panel Board:*

The whole process of brick making machine is being control either automatically or manually by using control panel board. Figure 6 below shows the part in control panel board of geopolymer brick making machine.

*Basic Operation:*

There are 4 components in the operation of geopolymer brick making machine in order to produce geopolymer brick, which are preparation of raw materials, mixing, moulding and compressing, and lastly curing. The operation was based on manual mode usage.

*Raw materials and preparation:*

This machine suitable for all kind of geopolymer material which can produce brick such as fly ash, kaolin, calcined kaolin, ground granulated blast furnace, oil palm ash and so on. The machine is suitable to be used with any kind of alkaline activator. The raw need to be prepared based on the mixing design before put into the mixer.

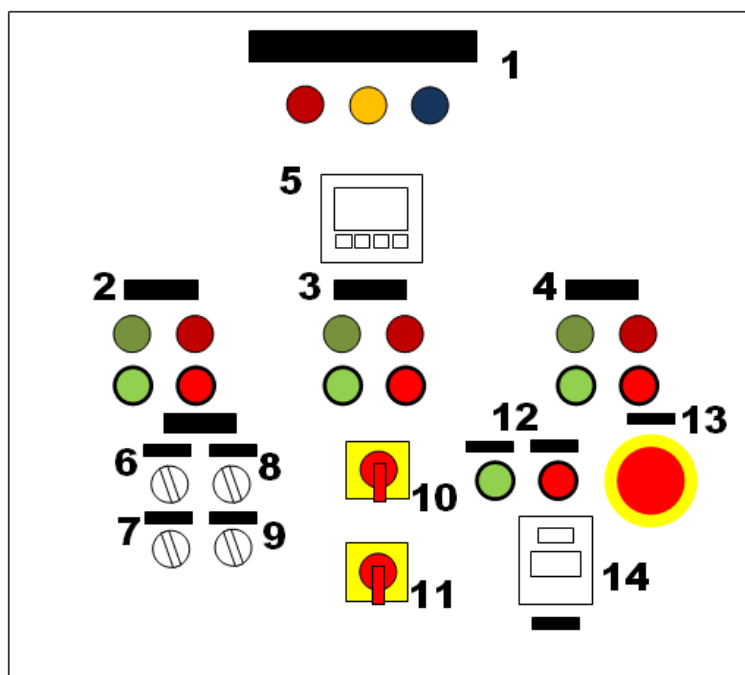

- |  |  |
|--|--|
| 1 Incoming Phase Indicator             | 8 Lower Cylinder for Compressor Switch |
| 2 Mixer On/Off Button                  | 9 Nozzle Open/Close Switch             |
| 3 Heater On/Off Button                 | 10 Auto/Manual Switch                  |
| 4 Curing Conveyor On/Off Button        | 11 Main On/Off Switch                  |
| 5 Temperature Control                  | 12 Auto Start/Auto Stop Button         |
| 6 Upper Cylinder for Compressor Switch | 13 Emergency Stop Button               |
| 7 Mixer Moving Switch                  | 14 Filing Time Control                 |

**Fig. 5:** Schematic Diagram of Control Panel Board.

*Mixing:*

The materials that had been prepared before which are various types of clay, sand, and alkaline activator should be weighed accordingly based on the design ratio. Then the materials need to be put into the mixer by following the sequence which is geopolymer material before sand and lastly alkaline activator accordance to the standard. The sequence is important due to different properties in each material that affect the mixing process. Before mixing it, the sand should be prepared in a right condition that is surface saturated dry. This condition is important to make sure that the sand does not add or absorb any solution in the mix. The source of material need to mix first before the alkaline activator was added to the mix. After all the material already being put into the mixer then press mixer button on. The duration of mixing process is depending on the design ratio and material used. Usually the mixing process does not take more than 20 minutes for each batch [12, 13, 14].

*Moulding and compressing:*

After the mixing already is mixed, on mixer moving switch then open the nozzle by switching on the nozzle switch. Then switch on upper cylinder button. After an accordance suitable time, switch off upper cylinder and switch on lower cylinder. To move the brick, switch on the mixer moving switch again. Then the brick will be move into the curing oven thru the extension conveyor.

*Curing:*

For curing operation, the brick will be automatically moved in and out of the oven by the stainless still belt at the curing conveyor oven. The temperature need to be set to required temperature before the brick being pulled into the oven by using oven temperature control at the control board. After the brick finish going thru the curing conveyor oven, the brick end product will go to end gravity conveyor and ready to be use.

*Pilot Plant Location and Layout:*

The development of pilot plant for geopolymer brick making machine were conducted in collaboration with the King Abdul Aziz City Science and Technology (KACST). The geopolymer brick making machine which being used in this research is being set up in the construction lab facilities at Center of Excellence Geopolymer & Green Technology, Universiti Malaysia Perlis. For the location of the machine, parameter like working space, electricity and other utilities had been considered. The layout of the machine involved arrangement of materials processing, handling, dumping storage, proper arrangement of the machine and related equipment and other facilities.

*Conclusion:*

The production process to make the geopolymer brick is easy and can produce high scale of brick quantity that can support the demand of the construction industry. The process of geopolymer brick making machine is suitable with geopolymerization process. It is potentially applicable to be used as a substitute construction material to replace commercial brick in the market.

**ACKNOWLEDGMENTS**

Gratitude to King Abdul Aziz City Science and Technology (KACST) for funded this research. We would like to extend our appreciation to the Center of Excellence Geopolymer & Green Technology and all the people who helped to ensure that the successful completion of this study.

**REFERENCES**

- [1] Habert, G., J.B. d'Espinose de Lacaillerie, N. Roussel, 2011. An environmental evaluation of geopolymer based concrete production: reviewing current research trends. *Journal of Cleaner Production*, 19(11): 1229e1238.
- [2] Habert, G., C. Billard, P. Rossi, C. Chen, N. Roussel, 2010. Cement production technology improvement compared to factor 4 objectives. *Cement and Concrete Research*, 40(5): 820e826.
- [3] Von Bahr, B., O.J. Hanssen, M. Vold, G. Pott, 2013. Experiences of environmental performance evaluation in the cement industry. Data quality of environmental performance indicators as a limiting factor for benchmarking and rating. *Journal of Cleaner Production*, 11(7): 713e725.
- [4] Huntzinger, D.N., T.D. Eatmon, 2009. A life-cycle assessment of Portland cement manufacturing: comparing the traditional process with alternative technologies. *Journal of Cleaner Production*, 17(7): 668e675.
- [5] Davidovits, J., in : Geopolymer chemistry and properties. 1988. Davidovits, J., Orlinsl, J.(Eds.), Proceedings of the First European Conference on Soft Mineralogy. The geopolymer Institute, Compiègne, pp: 25-48.
- [6] Abdul Aleem, M.I. and P.D. Arumairaj, 2012. Geopolymer concrete- A review, *International Journal of Engineering Sciences and Emerging Technologies*, 1(2): 118.
- [7] Abdullah, M.M.A., H. Kamarudin, H. Mohammed, I. Khairul Nizar, A.R. Rafiza, Y. Zarina, 2011. The relationship of NaOH molarity, Na<sub>2</sub>SiO<sub>3</sub>/NaOH ratio, fly ash/alkaline activator ratio, and curing temperature to the strength of fly ash-based geopolymer. *Advanced Materials Research* 328-330, pp: 1475-1482.
- [8] Mustafa Al Bakri, A.M., H. Kamarudin, I. Khairul Nizar, M. Bnhussain, Y. Zarina, A.R. Rafiza, 2011. Correlation between Na<sub>2</sub>SiO<sub>3</sub>/NaOH ratio and fly ash/alkaline activator ratio to the strength of geopolymer. *Advanced Materials Research*, 341-342 , pp: 189-193.
- [9] Fatih, T. and A. Umit, in Proceedings of the 2011 International Ash Utilization Symposium, Lexington, 2011, p. 1.
- [10] BS 3921 - 1985. Specifications of Clay Bricks.
- [11] Christopher Koroneos, 2006. Aris Dompros in Environmental assessment of brick production in Greece, 2006. *Building and Environment*, 42: 2114-2123.
- [12] Muhammad Faheem, M.T., A.M. Mustafa Al Bakri, H. Kamarudin, C.M. Ruzaidi, M. Binhussain and A.M. Izzat, 2013. The Relationship of Na<sub>2</sub>SiO<sub>3</sub>/NaOH Ratio, Kaolin/Alkaline Activator Ratio and Sand/Kaolin Ratio to the Strength of Kaolin - Based Geopolymer Brick. *Int. Review of Mech. Eng;* Vol. 7, N1.ISSN 1970-8734.
- [13] Wan Mastura, W. I., H. Kamarudin, I. Khairul Nizar, A.M. Mustafa Al Bakri, M. Bnhussain, 2013. Effect of Curing System on Properties of Fly Ash-based Geopolymer Bricks, *Int. Review of Mech. Eng.*, 7: N1.ISSN 1970-8734.
- [14] Wan Mastura, W.I., H. Kamarudin, I. Khairul Nizar, A.M.M. Al Bakri, 2013. Mechanical Performances of Fly Ash Geopolymer Bricks, *Advanced Science Letters*, 19(1): 186-189.