

# A new test procedure to measure the soil-water characteristic curves using a small-scale centrifuge

R. M. Khanzode,

*Graduate Student, University of Saskatchewan, Saskatoon, Canada, S7N 5A9*

D.G. Fredlund,

*Professor of Civil Engineering, University of Saskatchewan, Saskatoon, Canada, S7N 5A9*

S.K. Vanapalli

*Research Engineer, Royal Military College of Canada, Kingston, Canada, K7K 7B4*

**ABSTRACT:** The soil-water characteristic curve is conventionally measured using a pressure plate apparatus or a Tempe cell. Considerably long periods of time are required to measure the soil-water characteristic curves using the conventional equipment. A new test procedure is proposed, using a small-scale medical centrifuge to measure the soil-water characteristic curves for compacted, fine-grained soil specimens. Soil specimen holders were designed for the small-scale centrifuge. The soil-water characteristic curves of statically compacted specimens for three different fine-grained soils with varying percentages of clay were measured using the centrifuge for a suction range between 0 to 500 kPa. There is good comparison between the soil-water characteristic curves measured using the small-scale centrifuge and the conventional laboratory equipment. The results of this study are encouraging as soil-water characteristic curves can be measured in a shorter period of time, resulting in considerable savings.

## 1 INTRODUCTION

The engineering behavior of an unsaturated soil can be interpreted in terms of two stress state variables namely; net normal stress,  $(\sigma_n - u_a)$ , and matric suction,  $(u_a - u_w)$ , using experimental test results (Fredlund and Rahardjo 1993). Experimental techniques to determine the unsaturated soil properties are however costly and time consuming. In the last five years, several simple procedures have been proposed in the literature to predict the engineering behavior of unsaturated soils using the soil-water characteristic curve and the saturated soil properties. The procedures to predict the engineering behavior of unsaturated soils are simple and economical, and therefore useful to practicing geotechnical and geo-environmental engineers.

The soil-water characteristic curve defines the relationship between the soil suction and soil gravimetric water content,  $w$ , or volumetric water content,  $\theta_w$ , or the degree of saturation,  $S$ . Soil-water characteristic curves are commonly measured in the laboratory for a suction range between 0 to 1,000 kPa using conventional equipment. This suction range is of interest to the geotechnical and geo-environmental engineers. Typically, six to eight data points are measured such that the important features of the soil-water characteristic curve (i.e., the air-entry

value and the residual state conditions) can be determined from the measured data.

Conventional equipment used for the measurement of the soil-water characteristic curve includes the pressure plate or the Tempe cells. These apparatuses are reliable for measuring the soil-water characteristic curve behavior of both coarse and fine-grained soils, but considerable time is required. More details of these equipment and testing procedures are available in Fredlund and Rahardjo (1993).

The time period required for the measurement of the soil-water characteristic curve, using conventional testing procedures for soils such as sand or silt is between 6 to 8 days (for obtaining 6 to 8 data points). In other words, approximately one day is required to obtain one data point for relatively coarse-grained soils. Longer periods of time are required to measure the soil-water characteristic curves for fine-grained soils such as tills and clays. A time period of approximately 5 to 6 days is required for specimens to equilibrate under each value of soil suction. Typically, 4 to 6 weeks of time is required to obtain the soil-water characteristic curve for a fine-grained soil with a suction range of 0 to 1,000 kPa (i.e., for 6 to 8 data points).

Soil-water characteristic curves were measured for some coarse-grained and fine-grained soils using

the centrifuge technique (Gardner 1937, Russell and Richards 1938, Croney et al. 1952, Skibinsky 1996). However, centrifuge techniques are not conventionally used for the measurement of soil-water characteristic curves. Limited studies have been undertaken to measure the soil-water characteristics of fine-grained, compacted soil specimens using centrifuge techniques.

The centrifuge principle and technique for measuring the soil-water characteristic curve are provided in this paper. The design details of soil specimen holder are also described. Test result comparisons between the measured soil-water characteristic curve using conventional equipment and the proposed centrifuge technique for three different, fine-grained soils with varying percentages of clay is also presented and discussed.

## 2 PRINCIPLE OF THE CENTRIFUGE TECHNIQUE

A high gravity field is applied to the soil specimen supported on a saturated, porous ceramic column using the centrifuge. The base of the ceramic stone has a water table that is at atmospheric pressure conditions. The water content profile in soil specimen after attaining equilibrium conditions is similar to water draining under field conditions to a groundwater table where gravity is several times that on earth.

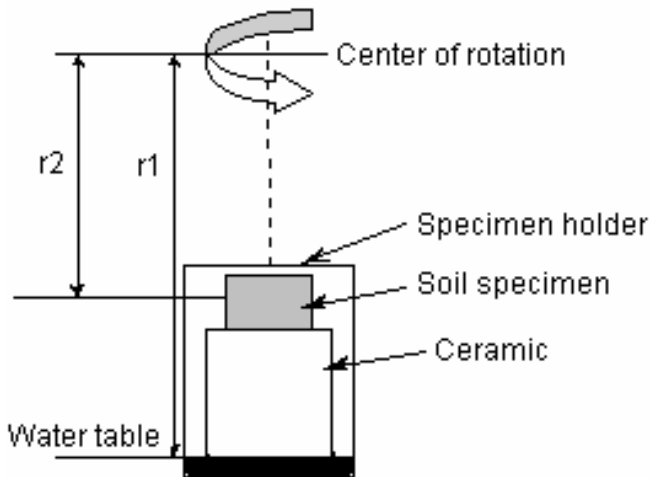

Figure 1. Suction measurement principle of the centrifuge.

Figure 1 demonstrates the suction measurement principle of the centrifuge method detailed earlier. The suction in the soil specimen in a centrifuge can be calculated using Eq. [1] proposed by Gardner (1937).

$$\psi = \frac{\rho\omega^2}{2}(r_2^2 - r_1^2) \quad [1]$$

where :

- $\psi$  = suction in the soil specimen
- $r_1$  = radial distance to the free water surface
- $r_2$  = radial distance to the midpoint of the soil specimen
- $\omega$  = angular velocity
- $\rho$  = density of the pore fluid

Equation 1 defines a non-linear relationship between suction and centrifugal radius. The soil suction,  $\psi$ , becomes a function of the difference of the squares of the centrifugal radii,  $r_1$  and  $r_2$  keeping the density,  $\rho$ , and the angular velocity,  $\omega$ , constant. The distance from the centre of rotation to the free water surface,  $r_1$ , is fixed and is a constant.

Different values of suction can be induced in the soil specimen by varying the radial distance to the midpoint of the soil specimen,  $r_2$ . This can be achieved by using ceramic cylinders of different heights. Higher values of suction can also be induced in soil specimens by increasing the test speed (i.e., angular velocity,  $\omega$ ).

## 3 SMALL-SCALE MEDICAL CENTRIFUGE

A J6-HC small-scale medical centrifuge with JS-4.2 rotor assembly with an operable radius of 254 mm was used in the research program. The JS-4.2 rotor assembly of the centrifuge consists of six swinging type buckets (Fig. 2). The buckets in the centrifuge are able to rotate at angular velocities varying from 300 to 4200 rpm. The maximum suction that can be induced in the specimen at 4200-rpm using this centrifuge is equal 2800 kPa. The swinging type buckets of the small-scale centrifuge, assumes horizontal position when the centrifuge is spinning. All the six buckets can be used simultaneously with six specimen holders for testing. The mass in all the specimen holders, however, should be the same to avoid rotary imbalance.

Specially designed soil specimen holders are required to accommodate the specimens in the centrifuge buckets. Six data points of water content versus suction can be obtained in a single test run using a J6-HC small-scale medical centrifuge at one particular angular velocity,  $\omega$ . Identical soil specimens have to be placed at different heights in the six specimen holders such that the six data points result in different water contents and suction values. The water content in the specimen can be measured from mass-volume relationships and the suction in the specimen can be estimated using Eq. [1].

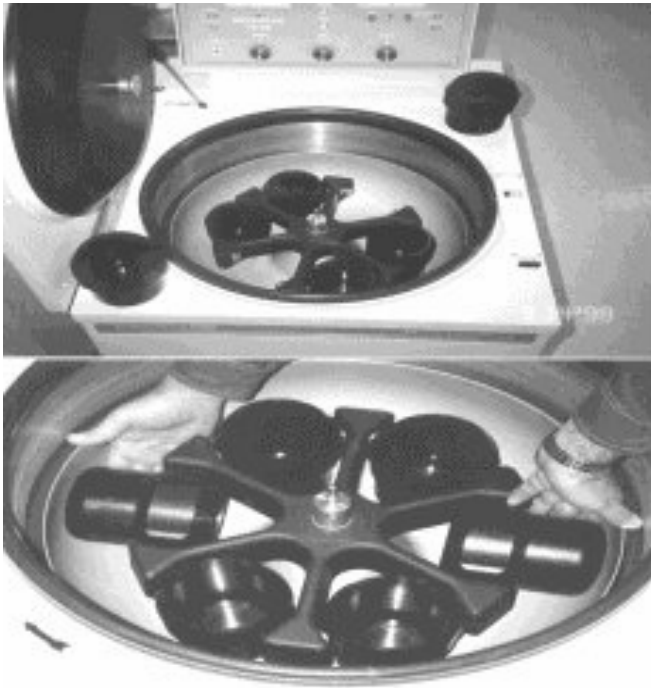

Figure 2. J6-HC centrifuge with six swinging type buckets of the JS-4.2 rotor assembly.

In the present study, only two swinging buckets were used during one test spin with two specimen holders. The remainder four buckets of the centrifuge were left empty without any specimen holders.

#### 4 SOIL SPECIMEN HOLDERS

Two aluminum soil specimen holders were specially designed for use in the J6-HC centrifuge to hold 10 to 15 mm thick soil specimens at different heights. Figure 3 shows a typical aluminum soil specimen holder used in the study. The soil specimen holder consists of five individual outer rings (inner diameter of 75mm and 15 mm thick), a drainage plate with a free water surface reservoir to accommodate a ceramic cylinder. A reservoir cup serves as a collection area for water extracted from the soil specimens at the base of the holder.

A porous cylinder was designed to act as a filter to prevent the movement of soil from the specimen to the drainage plate. This plate facilitates drainage into the reservoir cup through eight evenly spaced drainage ports drilled horizontally through sides of the plate. The horizontal overflow ports are connected to vertically drilled drainage holes to allow the removal of water from the soil specimen that flows down from the drainage plate into the reservoir cup.

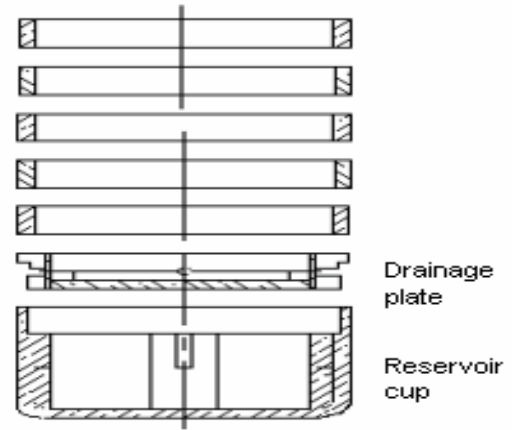

Figure 3. Aluminum soil specimen holder (from Skibinsky 1996).

#### 4.1 Ceramic cylinders

The ceramic cylinders used in the drainage plate were made up of 60% Kaolinite and 40% Aluminum Oxide. The porosity of the ceramic cylinders was equivalent to 45%. Ceramic cylinders of different heights in combination with different test speeds can be used to apply different suctions in the soil specimens.

In the present study, four ceramic cylinders with different heights of 15mm, 30mm, 45mm and 60 mm were used to keep the soil specimen at four different distances from the centre of rotation. This would enable the application of different suctions in the soil specimens at one constant test speed.



Figure 4. Saturated soil specimens on top of the saturated ceramic cylinders in the drainage plate.

The saturated ceramic cylinders are held in the drainage plate as shown in Figure 4 at the start of the test. The ceramic cylinder bottom rests in the free water surface reservoir in the drainage plate. The ceramic cylinder remains saturated during the entire period of spinning. The statically compacted, satu-

rated soil specimens are placed on top of the saturated cylinders such that there is a direct hydraulic connection between the pore-water in the soil specimens and the free water surface reservoir at the base of the ceramic cylinder.

Water from the saturated soil specimen escapes into the bottom reservoir through the ceramic cylinder and reaches equilibrium conditions when the specimen is centrifuged. The suction in the soil specimen will be equivalent to the applied centrifugal force after reaching equilibrium conditions.

Ceramic cylinders of two different heights were used in one test run to position the soil specimens at two different distances from the centre of rotation of the centrifuge. The soil specimens were subjected to two different centrifugal forces and different values of suction were induced in two identical soil specimens placed in the soil specimen holders, subjected to the same speed.

Different cylinder heights and increasing test speeds of 300, 500, 1000, 1500, 2000 and 2500 rpm were used in the present study. The soil-water characteristics were measured for a suction range from 0 kPa to 600 kPa. Table 1 shows the calculated suction values at the midpoint of the soil specimens using Eq. [1] for different distances from the centre of rotation at different test speeds.

Table 1. Suction associated with different test speeds and different ceramic cylinders

Test Speed in rpm	Suction in the soil specimen (kPa)			
	15 mm cylinder	30 mm cylinder	45 mm cylinder	60 mm cylinder
300	6.04	8.38	10.51	12.41
500	16.69	23.18	29.06	34.32
1000	67.11	93.26	116.8	138.8
1500	151.1	210.0	263.1	310.8
2000	268.7	373.3	467.7	552.5
2500	420.0	583.6	731.1	863.6

## 5 TEST PROGRAM

Three different fine-grained soils, namely, the Processed silt ( $w_L = 24\%$ ,  $I_p = 0$ , and Clay = 7%,  $G_s = 2.7$ ), Indian Head till ( $w_L = 35.5\%$ ,  $I_p = 17\%$ , and Clay = 30%,  $G_s = 2.73$ ) and Regina Clay ( $w_L = 75.5\%$  and  $I_p = 21\%$ , and Clay = 70%,  $G_s = 2.75$ ) were used for testing in the centrifuge. All the three soils were first air-dried and then pulverized. Pre-calculated amounts of water content was added to the soil and stored in polythene bags in a humidity-controlled room for 24 hours to attain uniform water content.

The Processed silt specimens were statically compacted at an initial water content,  $w$ , of 22% and a dry density,  $\rho_d$ , of 1.57 Mg/m<sup>3</sup>. For Indian Head till specimens, representing the wet of optimum conditions, soil specimens were statically compacted at an initial water content of 19.2% and  $\rho_d$  of 1.77 Mg/m<sup>3</sup>. The Regina clay specimens were statically compacted at an initial water content of 38% and  $\rho_d$  of 1.30 Mg/m<sup>3</sup>. All the specimens were statically compacted in steel rings of 50mm diameter and 15mm height. More details of soil properties and specimen preparation are available in Khanzode (1999).

## 6 TEST PROCEDURE

Ceramic cylinders of two different heights (i.e., 30mm and 60 mm) and the statically compacted soil specimens were saturated at the start of the test by submerging in a water bath for 24 hours. The centrifuge was started and allowed to run at 300 rpm for half an hour to adjust the temperature of the rotating chamber. All the tests were conducted at a constant temperature of 20° C. The ceramic cylinders and the drainage plates were then placed in respective specimen holders (Figure 4). The bottom end of the ceramic cylinder was placed such that it just dips into the reference free water reservoir in the drainage plate.

The masses of the saturated soil specimens were determined and the soil specimens were placed on the top of the ceramic cylinders. The top of ceramic cylinders was wetted before placing the specimens. A filter paper was placed between the saturated soil specimens and the ceramic cylinders to prevent loss of any soil from the soil specimen. The soil specimens were covered on top with an aluminum foil to prevent moisture loss by evaporation. Hollow aluminum spacer cylinders were then placed around the ceramic cylinders and the soil specimens.

The spacer cylinders were required as the soil specimens and the ceramic cylinders used had a diameter of 50 mm and the outer aluminum spacer rings of the holder had an inner diameter of 75 mm. The aluminum spacer rings were pushed down the side bolts around the aluminum spacer cylinders and tightened with nuts on the top.

The mass in the specimen holders was weighed before subjecting to spinning. An additional mass was placed in the reservoir cup of one of the specimen holders to balance the rotor. It was ensured that the difference in the masses between both the specimen holders was less than 0.5gms. The soil specimen holders were then placed in the centrifuge buckets as shown in Figure 5 before subjecting for centrifugation.

## 7 EXPERIMENTAL RESULTS & DISCUSSIONS



Figure 5. Soil specimen holders in the centrifuge buckets ready for centrifugation.

The specimens were centrifuged initially at a speed of 300 rpm until equilibrium conditions were attained. Two hours of rotation time was found to be sufficient to attain equilibrium conditions for soil specimens tested with a thickness of 15mm for silty soils. However, it was found that 2 hrs of centrifugation time was not sufficient to attain equilibrium conditions for the specimens of Indian Head till and Regina clay. Both these soils had higher percentage of fines in comparison to Processed silt. The time of centrifugation was increased in steps for these specimens to achieve equilibrium conditions. Table 2 summarizes the testing speeds along with the equilibration times used for all soils tested.

Table 2. Centrifugation time at different testing speeds

#	Test speed in rpm	Time of rotation in hrs		
		Silt	Till	Clay
1	300	2	2	4
2	500	2	2	6
3	1000	2	4	8
4	1500	2	4	8
5	2000	2	6	10
6	2500	2	6	12

The centrifuge was stopped after attaining equilibrium conditions at each speed tested and the masses of the soil specimens were determined. After the 2500 rpm run, the soil specimens were kept in an oven for water content determination. The water content values for the earlier test speeds were then back-calculated.

Figure 6 shows the comparison between the soil-water characteristic curves for the Processed silt, Indian Head till and Regina clay measured using Tempe cell, Pressure plate and the centrifuge method.

The soil-water characteristic curves were measured using Tempe cell for the Processed silt specimens compacted at an initial water content of 23% and dry density,  $\rho_d$ , of 1.68 Mg/m<sup>3</sup> in two weeks time (Wright 1999). The time period required for measuring the soil-water characteristic curve for Processed silt specimens compacted at an initial water content of 22% and dry density,  $\rho_d$ , of 1.57 Mg/m<sup>3</sup> using the centrifuge method was only 12 hours. The small differences in the soil-water characteristics for the Processed silt specimens may be associated with the differences in the dry densities and initial water contents at which the silt specimens were prepared.

A time period of 24 hours was required for Indian Head till specimens compacted at 19.2% (wet of optimum) initial water contents to obtain the soil-water characteristic curves using the centrifuge. However, the time required for identical Indian Head till specimens for the same suction range using the Tempe cell was 6 weeks. There is a good correlation between the soil-water characteristic curves obtained by both the two methods for 19.3% (wet of optimum) specimens.

Figure 6 also shows the comparison between the soil-water characteristic curves for the Regina clay measured using pressure plate and the centrifuge method. The soil-water characteristic curve using the centrifuge for Regina clay specimens were measured in 36 hours. A time period of almost 16 weeks was required to obtain the soil-water characteristic curve using pressure plate apparatus (Shuai 1996). The differences in soil-water characteristics can be associated mainly due to the variations in initial water content conditions.

Table 3 summarizes the time required by all the three types of soils to obtain the centrifuge as well as the Tempe cell and pressure plate soil-water characteristic curves.

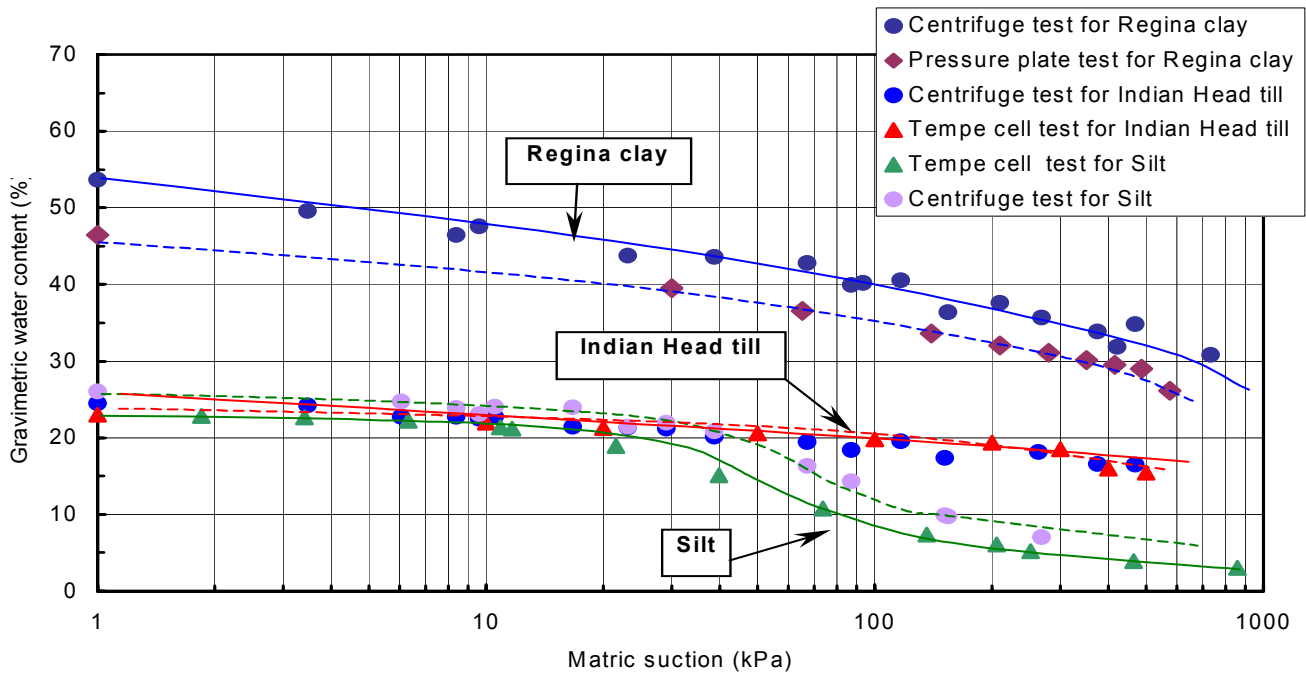

Figure 6. Comparison between the soil-water characteristic curves measured using the conventional procedure and the proposed new procedure using the small-scale medical centrifuge.

Table 3. Time periods to obtain the soil-water characteristic curve using centrifuge and conventional testing methods

Test Method	Silt	Indian Head till	Regina Clay
Centrifuge (time in days)	0.5	1	2
Tempe cell (time in days)	14	42	112

## 8 SUMMARY & CONCLUSIONS

The small-scale centrifuge can be used to obtain multiple water content versus suction data points of the soil-water characteristic curve. The time period for measuring the soil-water characteristic curves for compacted, fine-grained soils reduces considerably when using the centrifuge method. There is a good comparison between the experimental results obtained by using conventional procedures and the centrifuge for the three soils tested. The results of this study are encouraging to use the proposed centrifuge method for the determination of the soil-water characteristic curves for compacted, fine-grained soils.

## 9 REFERENCES

- Croney, D., Coleman, J.D., and Bridge, P.M. 1952. The suction of moisture held in soil and other porous materials. *Road Research Technical Paper*, No. 24. London.
- Fredlund, D.G. and Rahardjo, H. 1993. *Soil Mechanics for Unsaturated soils*. Inc., New York, NY, John Wiley and Sons
- Gardner, R. A. 1937. The method of measuring the capillary tension of soil moisture over a wide moisture range, *Soil Science*. **43**: 277-283.
- Khanzode, R.M. 1999. An alternative centrifuge method to obtain the soil-water characteristic curves for fine-grained soils. M.Sc. thesis, University of Saskatchewan. In progress.
- Russell, M.B., and Richards L.A. 1938. The determination of soil moisture energy relations by centrifugation. *Soil Sci. Soc. America*. Proceedings, **3**: 65-69.
- Skibinsky, D.N. 1996. A centrifuge method to obtain the soil-water characteristic curve. M.Sc. thesis, University of Saskatchewan.
- Shuai, F. 1996. Simulation of swelling pressure measurements on expansive soils. Ph.D. thesis, University of Saskatchewan.
- Wright, A. 1999. Shear strength of unsaturated soils in residual conditions. Undergraduate thesis. Civil Engineering Department, University of Saskatchewan.