

Contents lists available at ScienceDirect

Signal Processing

journal homepage: www.elsevier.com/locate/sigpro

Principles of minimum variance robust adaptive beamforming design

Sergiy A. Vorobyov

Department of Electrical and Computer Engineering, University of Alberta, Alberta, Canada T6G 2V4

ARTICLE INFO

Article history:

Received 2 August 2012

Received in revised form

19 October 2012

Accepted 29 October 2012

Dedicated to the memory of

Prof. Alex B. Gershman

Available online 16 November 2012

Keywords:

Robust adaptive beamforming

Convex optimization

ABSTRACT

Robustness is typically understood as an ability of adaptive beamforming algorithm to achieve high performance in the situations with imperfect, incomplete, or erroneous knowledge about the source, propagation media, and antenna array. It is also desired to achieve high performance with as little as possible prior information. In the last decade, several fruitful principles to minimum variance distortionless response (MVDR) robust adaptive beamforming (RAB) design have been developed and successfully applied to solve a number of problems in a wide range of applications. Such principles of MVDR RAB design are summarized here in a single paper. Prof. Gershman has actively participated in the development and applications of a number of such MVDR RAB design principles.

© 2012 Elsevier B.V. All rights reserved.

1. Introduction

Robust adaptive beamforming (RAB) was perhaps the favorite research topic of Prof. Gershman. He obtained a number of fundamental results that shaped the research in this field in the last two decades. Therefore, it is most appropriate to have in this special issue a tutorial paper devoted to the overview of the results in the RAB field with a stress on the most recent results. Alex himself has published as a single author or a coauthor two excellent tutorial papers on RAB and its applications [1,2]. The paper [1] has been published more than a decade ago and does not reflect the most recent progress in the field. Moreover, it is not devoted to the review of the design principles for minimum variance distortionless response (MVDR) RAB, but rather overviews the solutions to such particular RAB issues as robustness against pointing and antenna calibration errors [3–7], robustness against small sample size [8–11], robustness against coherent signal and interferers [12–16], robustness against imperfect wave-form coherence at sensor outputs [17–22], robustness

against moving and broadband interferences [23–28]. The paper [2] overviews the recent applications of adaptive and robust beamforming to new emerging fields in wireless communications such as downlink beamforming in cellular wireless networks [29], robust code-division multiple-access (CDMA) multiuser detection [30–32], linear receiver design for multi-access space-time coded systems [33,34], multicast beamforming [35,36], secondary multicast beamforming for spectrum sharing in cognitive radio systems [37], relay network beamforming [38], etc.

The emphasize of this tutorial paper is on the overview of some most notable principles of MVDR RAB design rather than the review of particular RAB techniques as in [1] or their applications as in [2]. The design principles will be explained based on the application to receive beamforming in array signal processing, radar, and sonar [39–45]. However, the same principles are used or can be used in other applications such as the above mentioned wireless communications (see also [46,47]) as well as speech processing [48], radio astronomy [49,50], biomedicine [51,52], and other fields.

The traditional approach to the design of adaptive beamforming is to maximize the beamformer output signal-to-interference-plus-noise ratio (SINR) assuming

E-mail addresses: svor@ieee.org, svorobyov@ualberta.ca

that there is no desired signal in the beamforming training data [40,42]. Although such desired signal free data assumption may be relevant to certain radar applications, the beamforming training snapshots include the desired signal component in most of the practical applications of interest [6,53–55]. In such non-ideal situation, the SINR performance of adaptive beamforming can severely degrade even in the presence of small signal steering vector errors/mismatches, because the desired signal component in the beamformer training data set can be mistakenly interpreted by the adaptive beamforming algorithm as an interferer and, consequently, it can be suppressed rather than being protected. The latter effect is known as signal cancellation phenomenon [56]. The steering vector errors are, however, very common in practice and can be caused by a number of reasons such as signal look direction/pointing errors; array calibration imperfections; non-linearities in amplifiers, A/D converters, modulators and other hardware; distorted antenna shape; unknown wavefront distortions/fluctuations; signal fading; near-far wavefront mismodeling; local scattering; and many other effects. Even if the steering vector of the desired signal is known perfectly, the performance degradation of adaptive beamformer can take place when the number of samples at the training stage is small [6]. To protect against multiple imperfections, the RAB has to be considered.

The particular design principles for MVDR RAB explained in this paper include the generalized sidelobe canceller [3,4,57], the regularization (diagonal loading) principle [53–55], the eigenspace projection principle [58], the design principles that use the worst-case optimization [59–67] and the outage probability constrained optimization [68,69], one-dimensional and multi-dimensional covariance fitting [63,67,70], eigenvalue beamforming using a multi-rank MVDR beamformer and subspace selection [71], and steering vector estimation with as little as possible prior information [72–75]. All the aforementioned design principles can be gathered under one unified design paradigm [75] which will also be explained. The MVDR RAB design principles will be explained based on the narrowband point source model. However, the extensions to the general-rank source model [76–79] and the broadband signal model [80–83] will also be briefly reviewed.

2. MVDR RAB principles

The MVDR RAB design principles are reviewed in this section based on the point source narrowband signal model. It is also assumed for simplicity that an antenna array has linear geometry and it consists of omnidirectional antenna elements.

2.1. Signal model

Consider a linear antenna array with M omni-directional antenna elements. The narrowband signal received by the antenna array at the time instant k is mathematically represented as

$$\mathbf{x}(k) = \mathbf{s}(k) + \mathbf{i}(k) + \mathbf{n}(k) \quad (1)$$

where $\mathbf{s}(k)$, $\mathbf{i}(k)$, and $\mathbf{n}(k)$ denote the $M \times 1$ vectors of the desired signal, interference, and noise, respectively. The desired signal is assumed to be uncorrelated with the interferers and noise, while the received signal is assumed to be zero-mean and quasi-stationary. Under the aforementioned point source assumption, the desired signal $\mathbf{s}(k)$ is expressed as

$$\mathbf{s}(k) = s(k)\mathbf{a}(\theta_s) \quad (2)$$

where $s(k)$ is the signal waveform and $\mathbf{a}(\theta_s)$ is the steering vector associated with the desired signal. This steering vector is a function of array geometry as well as source and propagation media characteristics such as, for example, the desired source direction-of-arrival (DOA) θ_s .

2.2. MVDR Beamformer

The beamformer output at the time instant k can be written as

$$y(k) = \mathbf{w}^H \mathbf{x}(k) \quad (3)$$

where \mathbf{w} is the $M \times 1$ complex weight (beamforming) vector of the antenna array and $(\cdot)^H$ stands for the Hermitian transpose.

In the case of a point source, under the assumption that the steering vector $\mathbf{a}(\theta_s)$ is known precisely, the optimal weight vector \mathbf{w} can be obtained by maximizing the beamformer output SINR given as

$$\text{SINR} \triangleq \frac{E[|\mathbf{w}^H \mathbf{s}|^2]}{E[|\mathbf{w}^H (\mathbf{i} + \mathbf{n})|^2]} = \frac{\sigma_s^2 |\mathbf{w}^H \mathbf{a}(\theta_s)|^2}{\mathbf{w}^H \mathbf{R}_{i+n} \mathbf{w}} \quad (4)$$

where $\sigma_s^2 \triangleq E[|s(k)|^2]$ is the desired signal power, $\mathbf{R}_{i+n} \triangleq E[(\mathbf{i}(k) + \mathbf{n}(k))(\mathbf{i}(k) + \mathbf{n}(k))^H]$ is the $M \times M$ interference-plus-noise covariance matrix, and $E[\cdot]$ denotes the expectation operator.

The MVDR beamformer is obtained by minimizing the denominator of (4), i.e., minimizing the variance/power of interference and noise at the output of the adaptive beamformer, while keeping the numerator (4) fixed, i.e., ensuring the distortionless response of the beamformer towards the direction of the desired source. The corresponding optimization problem is

$$\min_{\mathbf{w}} \mathbf{w}^H \mathbf{R}_{i+n} \mathbf{w} \quad \text{s.t.} \quad \mathbf{w}^H \mathbf{a}(\theta_s) = 1 \quad (5)$$

The solution of the optimization problem (5) is well known under the name MVDR beamformer and it is given as

$$\mathbf{w}_{\text{MVDR}} = \alpha \mathbf{R}_{i+n}^{-1} \mathbf{a}(\theta_s) \quad (6)$$

where $(\cdot)^{-1}$ denotes the inverse of a positive definite square matrix and $\alpha = 1/\mathbf{a}^H(\theta_s) \mathbf{R}_{i+n}^{-1} \mathbf{a}(\theta_s)$ is the normalization constant that does not affect the output SINR (4) and, therefore, will be omitted.

2.3. SMI Beamformer

The interference-plus-noise covariance matrix \mathbf{R}_{i+n} is unknown in practice, and it is substituted by the following

data sample covariance matrix:

$$\hat{\mathbf{R}} \triangleq \frac{1}{K} \sum_{k=1}^K \mathbf{x}(k)\mathbf{x}^H(k) \quad (7)$$

where K is the number of training data samples which also include the desired signal component. Note that other more sophisticated estimates of the data covariance matrix than (7) can be used [84,85].

The sample matrix inversion (SMI) adaptive beamformer [86] is obtained by replacing the interference-plus-noise covariance matrix \mathbf{R}_{i+n} in the MVDR beamformer (6) with the sample estimate of the data covariance matrix (7). Then the expression for the corresponding beamformer is given as

$$\mathbf{w}_{\text{SMI}} = \hat{\mathbf{R}}^{-1} \mathbf{a}(\theta_s). \quad (8)$$

Under the assumption shared by all traditional adaptive beamforming techniques that the desired signal component is not present in the training data, the requirement of the SMI beamformer on the number of training snapshots is given by the well known Reed–Mallett–Brennan (RMB) rule [86]: the mean losses relative to the optimal SINR due to the SMI approximation of \mathbf{w}_{MVDR} do not exceed 3 dB if $K \geq 2M$.

2.4. Motivations of RAB

If the desired signal component is present in the data vector \mathbf{x} , but the estimate of the data covariance matrix is perfect and the steering vector of the desired signal $\mathbf{a}(\theta_s)$ is known precisely, the SMI beamformer (8) is equivalent to the MVDR beamformer (6). Indeed, the data covariance matrix can be written as

$$\mathbf{R} = E[\mathbf{x}(k)\mathbf{x}^H(k)] = \sigma_s^2 \mathbf{a}(\theta_s)\mathbf{a}^H(\theta_s) + \mathbf{R}_{i+n} \quad (9)$$

Substituting (9) into (6) and applying the matrix inversion lemma, it can be obtained for the SMI beamformer that

$$\begin{aligned} \mathbf{R}^{-1} \mathbf{a}(\theta_s) &= (\mathbf{R}_{i+n} + \sigma_s^2 \mathbf{a}(\theta_s)\mathbf{a}^H(\theta_s))^{-1} \mathbf{a}(\theta_s) \\ &= \left(\mathbf{R}_{i+n}^{-1} - \frac{\mathbf{R}_{i+n}^{-1} \mathbf{a}(\theta_s)\mathbf{a}^H(\theta_s)\mathbf{R}_{i+n}^{-1}}{1/\sigma_s^2 + \mathbf{a}^H(\theta_s)\mathbf{R}_{i+n}^{-1}\mathbf{a}(\theta_s)} \right) \mathbf{a}(\theta_s) \\ &= \left(1 - \frac{\mathbf{a}^H(\theta_s)\mathbf{R}_{i+n}^{-1}\mathbf{a}(\theta_s)}{1/\sigma_s^2 + \mathbf{a}^H(\theta_s)\mathbf{R}_{i+n}^{-1}\mathbf{a}(\theta_s)} \right) \mathbf{R}_{i+n}^{-1} \mathbf{a}(\theta_s) \end{aligned} \quad (10)$$

where the coefficient $1 - \mathbf{a}^H(\theta_s)\mathbf{R}_{i+n}^{-1}\mathbf{a}(\theta_s)/(1/\sigma_s^2 + \mathbf{a}^H(\theta_s)\mathbf{R}_{i+n}^{-1}\mathbf{a}(\theta_s))$ is immaterial for the output SINR of the adaptive beamformer.

The result (10) on the equivalence between the MVDR and SMI beamformers holds true only under the conditions that (i) there is infinite number of snapshots available at the training stage and the data covariance matrix can be estimated with very high accuracy and (ii) the desired signal steering vector $\mathbf{a}(\theta_s)$ is known precisely. However, these conditions are not satisfied in practice since the data covariance matrix \mathbf{R} cannot be known exactly and its estimate $\hat{\mathbf{R}}$ typically contains the desired signal component where the desired signal steering vector $\mathbf{a}(\theta_s)$ may be known imprecisely. The inaccuracies in the knowledge of the desired signal steering vector may appear for multiple reasons associated with imperfect knowledge of the source

characteristics, propagation media and/or antenna array itself. Indeed, even small look direction errors can lead to significant degradation of the adaptive beamformer performance [57,87]. Similarly, an imperfect array calibration and distorted antenna shape can also lead to significant degradations [4]. Other common causes of the adaptive beamformer's performance degradation are the array manifold mismodeling due to source wavefront distortions resulting from environmental inhomogeneities [18], near-far problem [19], source spreading and local scattering [20–22], and so on. Other effects such as possible coherence between the desired signal and interferers also lead to the performance degradation [12–16]. We, however, assume that the desired signal is uncorrelated to interferers and noise and concentrate the discussion around the design principles of MVDR RAB while the techniques such as decorrelation of coherent sources are summarized in the existing tutorial [1].

2.5. Generalized sidelobe canceller

The simplest reason for the mismatch in the desired signal steering vector is the pointing error. Even a very slight look direction mismatch can lead to the effect that is known as the signal cancellation phenomenon when the adaptive beamformer misinterprets the desired signal with an interference and puts the null in the direction of the desired signal [56].

To stabilize the mainbeam response of adaptive beamformer in the case of pointing error, additional constraints are required in the MVDR beamforming. If all additional constraints are of the same type as the distortionless response constraint, i.e., linear constraints, the optimization problem can be reformulated as

$$\min_{\mathbf{w}} \mathbf{w}^H \mathbf{R} \mathbf{w} \quad \text{s.t.} \quad \mathbf{C}^H \mathbf{w} = \mathbf{f} \quad (11)$$

where \mathbf{C} and \mathbf{f} are some $Q \times M$ and $Q \times 1$ matrix and vector, respectively. Depending on the choice of \mathbf{C} or \mathbf{f} , we may have point or derivative mainbeam constraints [3,88]. For example, in the case of the point mainbeam constraints, the matrix of constrained directions is given as $\mathbf{C} = [\mathbf{a}(\theta_{s,1}), \mathbf{a}(\theta_{s,2}), \dots, \mathbf{a}(\theta_{s,Q})]$, where $\mathbf{a}(\theta_{s,q}), \forall q$ are taken in the neighborhood of the steering vector in the presumed direction $\mathbf{a}(\theta_s)$ and include the steering vector in the presumed direction as well. Then the vector of constraints \mathbf{f} is $\mathbf{f} = [1, 1, \dots, 1]^T$, where $(\cdot)^T$ stands for the transpose. The constraint in the optimization problem (11) consists of multiple point constraints similar to the distortionless response constraint, but covers not only the presumed direction, but also the directions in the neighborhood of the presumed direction. The disadvantage of using multiple distortionless response constraints is that additional degrees of freedom are used by the beamformer in order to satisfy these constraints. Since for an antenna array of M sensors, the number of degrees of freedom is M , the use of each additional degree of freedom for satisfying additional distortionless response constraints limits the remaining degrees of freedom that may be needed for suppressing interference signals.

The solution of the optimization problem (11) can be found in a similar way as the solution (6), and it is given as

$$\mathbf{w}_{\text{SMI}} = \mathbf{R}^{-1} \mathbf{C} (\mathbf{C}^H \mathbf{R}^{-1} \mathbf{C})^{-1} \mathbf{f}. \quad (12)$$

The solution (12) can be further decomposed into two components, one in the constrained subspace and the other in the orthogonal subspace to the constrained subspace, as follows [3]:

$$\mathbf{w}_{\text{opt}} = (\mathbf{P}_C + \mathbf{P}_C^\perp) \mathbf{w}_{\text{opt}} = \mathbf{C} (\mathbf{C}^H \mathbf{C})^{-1} \mathbf{C}^H \mathbf{R}^{-1} \mathbf{C} (\mathbf{C}^H \mathbf{R}^{-1} \mathbf{C})^{-1} \mathbf{f} + \mathbf{P}_C^\perp \mathbf{R}^{-1} \mathbf{C} (\mathbf{C}^H \mathbf{R}^{-1} \mathbf{C})^{-1} \mathbf{f} \quad (13)$$

where $\mathbf{P}_C \triangleq \mathbf{C} (\mathbf{C}^H \mathbf{C})^{-1} \mathbf{C}^H$ and $\mathbf{P}_C^\perp \triangleq \mathbf{I} - \mathbf{C} (\mathbf{C}^H \mathbf{C})^{-1} \mathbf{C}^H$ are the projection matrix on the constrained subspace and the orthogonal projection matrix on the constrained subspace, respectively.

The decomposition (13) can be written in a general form as

$$\mathbf{w}_{\text{GSC}} = \mathbf{w}_q - \mathbf{B} \mathbf{w}_a \quad (14)$$

where $\mathbf{w}_q = \mathbf{C} (\mathbf{C}^H \mathbf{C})^{-1} \mathbf{f}$ is the so-called quiescent beamforming vector, which is independent of the input/output data of the antenna array. The matrix \mathbf{B} in (14) must be selected so that $\mathbf{B}^H \mathbf{C} = \mathbf{0}$ and it is called the blocking matrix. The vector \mathbf{w}_a is the new adaptive weight vector, while \mathbf{w}_q is non-adaptive. The beamformer (14) is called the generalized sidelobe canceller (GSC).

The choice of the blocking matrix \mathbf{B} in the GSC (14) is not unique. In (13), for example, the blocking matrix $\mathbf{B} = \mathbf{P}_C^\perp$ is used. However, in this case, \mathbf{B} is not a full-rank matrix. Therefore, it is more common to select an $M \times (M-Q)$ full-rank matrix \mathbf{B} . Then, the vectors $\mathbf{z}(k) \triangleq \mathbf{B}^H \mathbf{x}(k)$ and \mathbf{w}_a both have shorter length of $(M-Q) \times 1$ relative to the $M \times 1$ vectors \mathbf{x} and \mathbf{w}_q . Since the non-adaptive component \mathbf{w}_q is data independent and has to be pre-computed only once, the GSC reduces the computational complexity by requiring to compute only the adaptive component \mathbf{w}_a of a shorter length.

To find the adaptive component \mathbf{w}_a , it can be observed that since the constrained directions are blocked by the matrix \mathbf{B} , the desired signal cannot be suppressed and, therefore, the weight vector \mathbf{w}_a can adapt freely to suppress interference by minimizing the output GSC power:

$$P_{\text{GSC}} = \mathbf{w}_{\text{opt}}^H \mathbf{R} \mathbf{w}_{\text{opt}} = (\mathbf{w}_q - \mathbf{B} \mathbf{w}_a)^H \mathbf{R} (\mathbf{w}_q - \mathbf{B} \mathbf{w}_a) = \mathbf{w}_q^H \mathbf{R} \mathbf{w}_q - \mathbf{w}_q^H \mathbf{R} \mathbf{B} \mathbf{w}_a - \mathbf{w}_a^H \mathbf{B}^H \mathbf{R} \mathbf{w}_q + \mathbf{w}_a^H \mathbf{B}^H \mathbf{R} \mathbf{B} \mathbf{w}_a. \quad (15)$$

The unconstrained minimization of (15) results in the following expression for the adaptive component of the GSC:

$$\mathbf{w}_{a,\text{opt}} = (\mathbf{B}^H \mathbf{R} \mathbf{B})^{-1} \mathbf{B}^H \mathbf{R} \mathbf{w}_q. \quad (16)$$

Noting that $y(k) \triangleq \mathbf{w}_q^H \mathbf{x}(k)$ and $\mathbf{z}(k) \triangleq \mathbf{B}^H \mathbf{x}(k)$, the following covariance matrix of the data vector $\mathbf{z}(k)$ and the correlation vector between $\mathbf{z}(k)$ and $y(k)$ can be introduced as $\mathbf{R}_z \triangleq E[\mathbf{z}(k) \mathbf{z}^H(k)] = \mathbf{B}^H E[\mathbf{x}(k) \mathbf{x}^H(k)] \mathbf{B} = \mathbf{B}^H \mathbf{R} \mathbf{B}$ and $\mathbf{r}_{yz} \triangleq E[\mathbf{z}(k) y^*(k)] = \mathbf{B}^H E[\mathbf{x}(k) \mathbf{x}^H(k)] \mathbf{w}_q = \mathbf{B}^H \mathbf{R} \mathbf{w}_q$. Using these notations, the expression (16) can be rewritten as

$$\mathbf{w}_{a,\text{opt}} = \mathbf{R}_z^{-1} \mathbf{r}_{yz} \quad (17)$$

which is a similar to SMI beamformer expression for finding optimal \mathbf{w}_a of a shorter length than \mathbf{w} after the desired signal direction is already protected.

The main disadvantage of the GSC is the very specific type of the desired signal steering vector mismatch considered, which limits its applicability. The GSC is also used for broadband adaptive beamforming [3]. If the matrix \mathbf{C} contains a single column, that is, the presumed steering vector, the GSC boils down to the standard MVDR beamformer (6).

2.6. Regularization (diagonal loading) principle

The presence of the desired signal in the training data may dramatically reduce the convergence rate of adaptive beamforming algorithms even if the desired signal steering vector is precisely known [6]. It is especially so in the situation of small training sample size. The RMB rule for the SMI adaptive beamformer (8) does not hold in such situations any longer.

In order to penalize the imperfections of the data covariance matrix estimate due to small sample size as well as imperfections in the knowledge of the desired signal steering vector, the regularization principle [89] can be used. Specifically, adding a regularization term in the objective function of the optimization problem (5) and using the sample data covariance matrix, the problem can be reformulated as

$$\min_{\mathbf{w}} \mathbf{w}^H \hat{\mathbf{R}} \mathbf{w} + \gamma \|\mathbf{w}\|^2 \quad \text{s.t.} \quad \mathbf{w}^H \mathbf{a}(\theta_s) = 1 \quad (18)$$

where γ is some penalty parameter and $\|\cdot\|$ denotes the Euclidian norm of a vector. The solution to the problem (18) after omitting the immaterial scaling factor α is given by the well known diagonally loaded or shortly just loaded SMI (LSMI) beamformer [53–55]:

$$\mathbf{w}_{\text{LSMI}} = (\hat{\mathbf{R}} + \gamma \mathbf{I})^{-1} \mathbf{a}(\theta_s) \quad (19)$$

where the empirically optimal penalty weight γ equals to double the noise power [53]. LSMI beamformer allows to converge faster than in 2 M snapshots as suggested by RMB rule. Particularly, the LSMI convergence rule is formulated as follows. The mean losses relative to the optimal SINR due to the LSMI approximation of (6) do not exceed a few dB's if the number of training snapshots is equal or larger than the number of interference signals. The fact that for a properly selected γ the LSMI beamformer is also efficient in the case when the desired signal steering vector is mismatched will be explained in details later. However, the choice of γ is not a trivial problem for the LSMI beamformer.

2.7. Eigenspace projection principle

Hereafter, the imperfectly known presumed desired signal steering vector is denoted as \mathbf{p} , while \mathbf{a} stands for the actual desired signal steering vector that is different from \mathbf{p} , i.e., $\mathbf{a} \neq \mathbf{p}$. The estimate of the actual desired signal steering vector is denoted as $\hat{\mathbf{a}}$.

Using a priori knowledge on the presumed desired signal steering vector \mathbf{p} , the eigenspace projection-based RAB computes and uses the projection of \mathbf{p} onto the sample signal-plus-interference subspace as a corrected estimate of the actual desired signal steering vector.

The eigendecomposition of (7) yields $\hat{\mathbf{R}} = \mathbf{E}\mathbf{A}\mathbf{E}^H + \mathbf{G}\mathbf{F}\mathbf{G}^H$, where the $M \times (L+1)$ matrix \mathbf{E} and $M \times (M-L-1)$ matrix \mathbf{G} contain the signal-plus-interference subspace eigenvectors of $\hat{\mathbf{R}}$ and the noise subspace eigenvectors, respectively, while the $(L+1) \times (L+1)$ matrix \mathbf{A} and $(M-L-1) \times (M-L-1)$ matrix \mathbf{F} contain the eigenvalues corresponding to \mathbf{E} and \mathbf{G} , respectively, and as before L stands for the number of interfering signals.

The estimate of the actual desired signal steering vector is found as

$$\hat{\mathbf{a}} = \mathbf{E}\mathbf{E}^H \mathbf{p} \quad (20)$$

where $\mathbf{E}\mathbf{E}^H$ is the projection matrix to the desired signal-plus-interference subspace. Then the eigenspace-based beamformer is obtained by substituting the so-obtained estimate of the steering vector to the SMI beamformer (8), and it can be expressed as [58]

$$\mathbf{w}_{\text{eig}} = \hat{\mathbf{R}}^{-1} \hat{\mathbf{a}} = \hat{\mathbf{R}}^{-1} \mathbf{E}\mathbf{E}^H \mathbf{p} = \mathbf{E}\mathbf{A}^{-1} \mathbf{E}^H \mathbf{p}. \quad (21)$$

Summarizing, the essence of the eigenspace projection principle is to project the presumed desired signal steering vector onto the measured signal-plus-interference subspace prior to processing in order to reduce the signal wavefront mismatch. Then, the estimate of the actual desired signal steering vector is plugged to the standard SMI beamformer. The interference rejection part remains unchanged for this beamformer as compared to the SMI beamformer. The prior information used is the presumed steering vector \mathbf{p} and the number of interfering sources L . Moreover, it is required that the noise components at antenna elements are mutually uncorrelated and have the same power. The notion of robustness is the projection of the presumed steering vector to the signal-plus-interference subspace. It is, however, well known that at low signal-to-noise ratio (SNR), the eigenspace-based beamformer suffers from a high probability of subspace swap and incorrect estimation of the signal-plus-interference subspace dimension [90].

2.8. The worst-case optimization-based RAB design principle

This RAB design principle is based on modeling the actual desired signal steering vector \mathbf{a} as a sum of the presumed steering vector and a deterministic norm bounded mismatch vector δ : $\mathbf{a} \triangleq \mathbf{p} + \delta$, $\|\delta\| \leq \varepsilon$, where ε is some a priori known bound. Thus, the worst-case optimization-based RAB uses the prior information about the presumed steering vector and the information that the mismatch vector is norm bounded [59]. An ellipsoidal uncertainty region can also be considered instead of the mentioned above spherical uncertainty [60]. However, a more sophisticated prior information has to be available in the case of ellipsoidal uncertainty. Assuming spherical uncertainty for δ , the uncertainty set can be represented as $\mathcal{A}(\delta) \triangleq \{\mathbf{a} = \mathbf{p} + \delta \mid \|\delta\| \leq \varepsilon\}$. Then the worst-case optimization-based RAB aims at solving the following optimization problem [59]:

$$\min_{\mathbf{w}} \mathbf{w}^H \hat{\mathbf{R}} \mathbf{w} \quad \text{s.t.} \quad \min_{\mathbf{a} \in \mathcal{A}(\delta)} |\mathbf{w}^H \hat{\mathbf{a}}| \geq 1. \quad (22)$$

The optimization problem (22) is equivalent to the following second-order cone (SOC) programming problem [59]:

$$\min_{\mathbf{w}} \mathbf{w}^H \hat{\mathbf{R}} \mathbf{w} \quad \text{s.t.} \quad \mathbf{w}^H \mathbf{p} \geq \varepsilon \|\mathbf{w}\| + 1 \quad (23)$$

which can be solved efficiently using standard numerical optimization methods with complexity comparable to the complexity of matrix inversion.

For the future discussion, it is worth mentioning that many modern RAB techniques are based on convex optimization theory [91]. Most of such RAB techniques cannot be expressed in closed-form, but the complexity of solving optimization problems that correspond to such RAB techniques is comparable to the complexity of the closed-form solutions like the SMI beamformer. Indeed, the most computationally costly operation of the SMI beamformer is the matrix inversion. Although strictly speaking the matrix inversion is not a closed-form operation, we call such solution to be closed-form following the tradition in array signal processing field. The complexity of matrix inversion is of order 3 the dimension of the matrix. The numerical solution of the worst-case optimization-based RAB problem (23) has a comparable computational complexity of order 3.5 of the dimension of the sample data covariance matrix. Thus, there is no significant difference in terms of computational complexity between the so-called closed-form solutions and numerical solutions of convex problems.

2.9. RAB using one-dimensional covariance fitting principle

The above worst-case optimization-based RAB design principle can be equivalently interpreted in terms of the use of the standard SMI beamformer in tandem with the desired signal steering vector estimation obtained using the covariance fitting approach. Specifically, the desired signal steering vector estimate is obtained by solving the following problem [63]:

$$\min_{\hat{\mathbf{a}}} \sigma_s^2 \quad \text{s.t.} \quad \hat{\mathbf{R}} - \sigma_s^2 \hat{\mathbf{a}} \hat{\mathbf{a}}^H \succcurlyeq 0 \quad (24)$$

for any $\hat{\mathbf{a}}$ satisfying $\|\delta\| \leq \varepsilon$

where the notation $\succcurlyeq 0$ indicates that the matrix on the left-hand side is positive semi-definite. It is worth to note that the corresponding MVDR RAB coincides with (22). It is because the same model for actual desired signal steering vector is used.

Summarizing, the prior information used in the worst-case optimization-based RAB design as well as in the RAB based on one-dimensional covariance fitting design principles is the presumed steering vector and the value ε , which may be difficult to obtain in practice. The notion of robustness is the uncertainty region for the presumed steering vector. The robustness to the rapidly moving interference sources can also be added to the worst-case optimization-based RAB design [64].

The RAB based on one-dimensional covariance fitting principle can be extended to the doubly constrained RAB [67]. The doubly constrained RAB is similar to the worst-case optimization-based one (22) (equivalently (24)), but it exposes also an additional constraint on the norm of the

desired signal steering vector estimate, that is, $\|\hat{\mathbf{a}}\|^2 = M$. Then the corresponding optimization problem for finding $\hat{\mathbf{a}}$ is

$$\min_{\sigma_s^2, \hat{\mathbf{a}}} \sigma_s^2 \quad \text{s.t.} \quad \hat{\mathbf{R}} - \sigma_s^2 \hat{\mathbf{a}} \hat{\mathbf{a}}^H \succcurlyeq 0$$

for any $\hat{\mathbf{a}}$ satisfying $\|\delta\| \leq \varepsilon$, $\|\hat{\mathbf{a}}\|^2 = M$. (25)

This beamforming approach uses the same prior information as the worst-case optimization-based RAB. Clearly, the notion of robustness for this method is the same as well. Due to the constraint $\|\hat{\mathbf{a}}\|^2 = M$, the doubly constrained RAB provides a better estimate of the desired signal in the applications where such estimate is needed.

2.10. Relationship between the worst-case and regularization RAB design principles

The constraint in the optimization problem (22) must be satisfied with equality at optimality. Indeed, if the constraint is not satisfied with equality, then the minimum of the objective function in (22) is achieved when $\kappa \triangleq \min_{\mathbf{a} \in \mathcal{A}(\delta)} |\mathbf{w}^H \mathbf{a}| > 1$. However, by replacing \mathbf{w} with $\mathbf{w}/\sqrt{\kappa}$, the objective function of (22) can be decreased by the factor of $\kappa > 1$, whereas the constraint in (22) will be still satisfied. This contradicts the original statement that the objective function is minimized when $\kappa > 1$. Therefore, the minimum of the objective function is achieved at $\kappa = 1$, and the inequality constraint in (22) is equivalent to the equality constraint. This also means that $\mathbf{w}^H \mathbf{a}$ is real-valued and positive. Using these facts, the problem (22) can be rewritten as

$$\min_{\mathbf{w}} \mathbf{w}^H \hat{\mathbf{R}} \mathbf{w} \quad \text{s.t.} \quad (\mathbf{w}^H \mathbf{p} - 1)^2 = \varepsilon^2 \mathbf{w}^H \mathbf{w}. \quad (26)$$

The solution to (26) can be found by using the method of Lagrange multipliers, i.e., by optimizing the following Lagrangian:

$$L(\mathbf{w}, \lambda) = \mathbf{w}^H \hat{\mathbf{R}} \mathbf{w} + \lambda (\varepsilon^2 \mathbf{w}^H \mathbf{w} - (\mathbf{w}^H \mathbf{p} - 1)^2) \quad (27)$$

where λ is a Lagrange multiplier. Taking the gradient of (27) and equating it to zero, it can be found that

$$\mathbf{w} = -\lambda (\hat{\mathbf{R}} + \lambda \varepsilon^2 \mathbf{I} - \lambda \mathbf{p} \mathbf{p}^H)^{-1} \mathbf{p}. \quad (28)$$

Furthermore, applying the matrix inversion lemma to (28), the beamforming vector can be expressed as [59]

$$\mathbf{w} = \frac{\lambda}{\lambda \mathbf{p}^H (\hat{\mathbf{R}} + \lambda \varepsilon^2 \mathbf{I})^{-1} \mathbf{p} - 1} (\hat{\mathbf{R}} + \lambda \varepsilon^2 \mathbf{I})^{-1} \mathbf{p} \quad (29)$$

which is the LSMI beamformer with adaptive diagonal loading factor. The expression (29) cannot be used practically since the optimal value of λ has to be first found. The numerical algorithms designed in [60] are particularly based on finding λ numerically, while the general SOC programming is used in [59]. The complexity of both type of methods is, however, the same and is comparable to the matrix inversion as in SMI and LSMI beamformers.

2.11. Unified framework to MVDR RAB design

It is interesting to note now that the aforementioned different MVDR RAB design principles, which use different

specific notions of robustness, can be all explained based on the same design framework. Indeed, the signal cancellation effect for the SMI beamformer occurs in the situation when the desired signal steering vector is misinterpreted with any of the interference steering vectors or their linear combinations. Thus, if with incomplete and/or imperfect prior information, a RAB technique is able to estimate the desired signal steering vector so that the estimate does not converge to any of the interferences and their linear combinations, such technique is robust. Using this general notion of robustness (versus specific notions of robustness mentioned above to motivate each of the aforementioned techniques), the unified framework to MVDR RAB design can be formulated as follows. Use the standard SMI beamformer (8) in tandem with the desired signal steering vector estimation performed based on some possibly incomplete and imperfect prior information [75]. The differences between different MVDR RAB design principles can be then shown to boil down to the differences in the assumed prior information, the specific notions of robustness, and the corresponding steering vector estimation techniques used [75]. This unified framework to MVDR RAB design can be used for developing other design principles as we explain in what follows.

2.12. The MVDR RAB design principle based on outage probability constrained optimization

The other MVDR RAB design principle is based on the assumption that the mismatch vector δ is random (versus the deterministic norm-bounded as in the worst-case optimization-based design). Then the problem has to be formulated in probabilistic terms. Specifically, the probabilistically constrained RAB problem is formulated as [68]

$$\min_{\mathbf{w}} \mathbf{w}^H \hat{\mathbf{R}} \mathbf{w} \quad \text{s.t.} \quad \Pr\{|\mathbf{w}^H \mathbf{a}| \geq 1\} \geq p_0 \quad (30)$$

where $\Pr\{\cdot\}$ denotes probability and p_0 is preselected probability value. In this case, the prior information is the presumed steering vector \mathbf{p} as before, but since the steering vector mismatch is assumed to be random, the other prior information is the distribution type and the distribution covariance of δ as well as the non-outage probability p_0 for the distortionless response constraint. In two cases when δ is Gaussian distributed and the distribution of δ is unknown and assumed to be the worst possible, it has been shown that the problem (30) can be tightly approximated by the following problem [68]:

$$\min_{\mathbf{w}} \mathbf{w}^H \hat{\mathbf{R}} \mathbf{w} \quad \text{s.t.} \quad \tilde{\varepsilon} \|\mathbf{Q}_\delta^{1/2} \mathbf{w}\| \leq \mathbf{w}^H \mathbf{p} - 1 \quad (31)$$

where \mathbf{Q}_δ is the covariance matrix of the random mismatch vector δ and $\tilde{\varepsilon} = \sqrt{-\ln(1-p_0)}$ if δ is Gaussian distributed and $\tilde{\varepsilon} = 1/\sqrt{1-p_0}$ if the distribution of δ is unknown. Thus, the latter problem boils down mathematically to the same form as the worst-case optimization-based RAB formulation and can be considered as a part of the unified framework. However, the prior information required by the MVDR RAB design principle based on the outage probability constrained optimization may be easier to obtain than that required by the worst-case optimization-based one since it is typically easier to estimate the statistics of the mismatch distribution

reliably, while p_0 has a clear physical meaning. The non-outage probability is the specific notion of robustness used in this approach.

2.13. RAB using multi-dimensional covariance fitting principle

It has been observed in [70] that the refined estimate of the desired signal steering vector obtained using the RAB based on one-dimensional covariance fitting principle tends towards the principal eigenvector of the sample covariance matrix. This principal eigenvector, however, does not entirely correspond to the desired signal, but rather is a weighted sum of the steering vectors of all sources including the interference sources. It results in the fact that the application of the RAB based on one-dimensional covariance fitting principle can lead to an erroneous estimate of the desired signal steering vector in the presence of interferers. Therefore, to reduce the detrimental effect of interferers on the desired signal steering vector estimate, the RAB based on one-dimensional covariance fitting principle has been extended to the RAB based on multi-dimensional covariance fitting in [70].

Assuming that the steering vectors of the desired source and interfering sources are all linearly independent, the RAB based on one-dimensional covariance fitting optimization problem (24) can be extended to the RAB based on multi-dimensional covariance fitting by replacing (24) with the following optimization problem [70]:

$$\begin{aligned} & \max_{\hat{\mathbf{A}}, \hat{\mathbf{P}}, \hat{\sigma}_n^2} \log \det(\hat{\mathbf{A}}\hat{\mathbf{P}}\hat{\mathbf{A}}^H + \hat{\sigma}_n^2\mathbf{I}) \\ & \text{s.t. } \hat{\mathbf{R}} - \hat{\mathbf{A}}\hat{\mathbf{P}}\hat{\mathbf{A}}^H - \hat{\sigma}_n^2\mathbf{I} \succeq \mathbf{0} \\ & \|(\hat{\mathbf{A}} - \tilde{\mathbf{A}})\mathbf{e}_l\| \leq \varepsilon_l \forall l, \quad \hat{\mathbf{P}} \odot \mathbf{I}_{L+1} \succeq \mathbf{0} \end{aligned} \quad (32)$$

where $\tilde{\mathbf{A}} \triangleq [\tilde{\mathbf{a}}, \tilde{\mathbf{a}}_1, \dots, \tilde{\mathbf{a}}_L]$ is the $M \times (L+1)$ matrix of the source steering vector estimates, $\tilde{\mathbf{a}}_l$ is an estimate of the steering vector of l th interference source, ε_l is an estimated upper bound on $\|\tilde{\mathbf{a}}_l - \mathbf{a}_l\|$, $\hat{\mathbf{A}}$ is the optimization variable standing for the matrix of source steering vectors, $\hat{\mathbf{P}}$ is the optimization variable standing for the $(L+1) \times (L+1)$ source covariance matrix, $\hat{\sigma}_n^2$ is the optimization variable standing for the noise power, \mathbf{e}_l is the unit column-vector whose l th entry is equal to one and all other entries are equal to zero, and \odot denotes the Schur–Hadamard element-wise matrix product. The last constraint in (32) ensures that the matrix $\hat{\mathbf{P}}$ is positive semi-definite and diagonal. A multiple steering vector uncertainty sets are used here, one per each steering vector, and they are assumed to be sufficiently separated one from another so that the columns of $\hat{\mathbf{A}}$ are pairwise linearly independent. The optimization problem (32) is based on a maximum volume inscribed ellipsoid approach, it is not convex, but its approximate version can be efficiently solved [70]. Clearly the solution of an approximate version of (32) contains refined estimates of the steering vectors of all sources. The beamformer weight vector is computed subsequently based on the MVDR expression, using the refined estimate of the desired signal steering vector just as in the RAB based on one-dimensional covariance fitting case.

In addition to the prior information used by the RAB based on one-dimensional covariance fitting principle, the RAB based on multi-dimensional covariance fitting extension uses information about the interferer steering vectors to compute a refined estimate of the desired signal steering vector. Thus, in fact, it requires more prior information that goes against the general notion of robustness mentioned above. Moreover, the desired signal, interferers, and noise components are assumed to be uncorrelated as well as the noise waveforms are assumed to have the same power in all antenna elements for the RAB based on one-dimensional covariance fitting principle. However, the RAB based on multi-dimensional covariance fitting principle outperforms the RAB based in one-dimensional covariance fitting principle in the scenarios with large sample size and, thus, is competitive in the scenarios when it is applicable.

2.14. Eigenvalue beamforming using multi-rank MVDR beamformer

Let the desired signal and interference steering vectors lie in known signal subspaces and the rank of the signal correlation matrix is known. For example, let us consider the case when the interference and desired signals have the same structure and are modeled as signals with a rank-one covariance matrix from a p -dimensional subspace. The corresponding steering vector of the desired and interference signals are all modeled as $\mathbf{s} = \Psi\mathbf{b}_0$ where Ψ is an $M \times p$ ($p < M$) matrix whose columns are orthogonal ($\Psi^H\Psi = \mathbf{I}_{p \times p}$) and \mathbf{b}_0 is an unknown but fixed vector over the snapshots. The matrix Ψ is different for each signal and is obtained by choosing p dominant eigenvectors of the matrix $\int_{\phi_p - \Delta\phi}^{\phi_p + \Delta\phi} \mathbf{d}(\theta)\mathbf{d}^H(\theta)d\theta$ (here $\mathbf{d}(\theta)$ is the steering vector associated with direction θ and having the structure defined by the antenna geometry) as the columns of Ψ where ϕ_p denotes the presumed location of the source and $\Delta\phi$ is the phase shift that is the same for all the signals. Then, the eigenvalue beamforming using multi-rank MVDR beamformer can be efficient [71]. The multi-rank beamformer matrix is computed as [71]

$$\mathbf{W} = \hat{\mathbf{R}}^{-1}\Psi(\Psi^H\hat{\mathbf{R}}^{-1}\Psi)^{-1}\mathbf{Q} \quad (33)$$

where \mathbf{Q} is a data dependent left-orthogonal matrix, i.e., $\mathbf{Q}^H\mathbf{Q} = \mathbf{I}$. For example, for resolving a signal with a rank-one covariance matrix, i.e., a point source, and an unknown but fixed DOA, the columns of \mathbf{Q} should be selected as the dominant eigenvectors of the error covariance matrix $\mathbf{R}_e = (\Psi^H\hat{\mathbf{R}}^{-1}\Psi)^{-1}$. If it is assumed that the signal lies in a known subspace, but the DOA is unknown and unfixed (randomly changes from snapshot to snapshot), it is the subdominant eigenvectors of the error covariance matrix that should be used as the columns of the matrix \mathbf{Q} .

The prior information required for this beamforming is the linear subspace in which the desired signal lies and the rank of the desired signal covariance matrix. The main disadvantages are that a very specific modeling of the

covariance matrix is used and the signal subspace has to be known.

2.15. The MVDR RAB design principle based on steering vector estimation with the knowledge of the angular sector

According to this MVDR RAB design principle, the estimate of the actual steering vector \mathbf{a} is found so that the beamformer output power is maximized while the convergence of the estimate $\hat{\mathbf{a}}$ to any interference steering vector is prohibited [72]. This principle is also based on and, in fact, motivated by the above explained unified framework to the MVDR RAB design. The rationale behind maximization of the beamformer output power is the following. In the steering vector mismatched case, the solution (8) can be written as a function of unknown δ as $\mathbf{w}(\delta) = \hat{\mathbf{R}}^{-1}(\mathbf{p} + \delta)$. Using $\mathbf{w}(\delta)$, the beamformer output power can be also written as a function of the mismatch δ as

$$P(\delta) = \frac{1}{(\mathbf{p} + \delta)^H \hat{\mathbf{R}}^{-1} (\mathbf{p} + \delta)}. \quad (34)$$

Thus, the estimate of δ or, equivalently, the estimate of $\mathbf{a} \triangleq \mathbf{p} + \delta$ that maximizes (34) is the best estimate of the actual steering vector \mathbf{a} under the constraints that the norm of $\hat{\mathbf{a}}$ equals \sqrt{M} and $\hat{\mathbf{a}}$ does not converge to any of the interference steering vectors. The latter is guaranteed by requiring that

$$\mathbf{P}^\perp(\mathbf{p} + \hat{\delta}) = \mathbf{P}^\perp \hat{\mathbf{a}} = 0 \quad (35)$$

where $\mathbf{P}^\perp \triangleq \mathbf{I} - \mathbf{U}\mathbf{U}^H$, $\mathbf{U} \triangleq [\mathbf{u}_1, \mathbf{u}_2, \dots, \mathbf{u}_T]$, $\mathbf{u}_l, l = 1, \dots, T$ are the T dominant eigenvectors of the matrix $\mathbf{C} \triangleq \int_{\Theta} \mathbf{d}(\theta) \mathbf{d}^H(\theta) d\theta$, $\mathbf{d}(\theta)$ is the steering vector associated with direction θ and having the structure defined by the antenna geometry, Θ is the angular sector in which the desired source is located, $\hat{\delta}$ and $\hat{\mathbf{a}}$ stand for the estimates of the steering vector mismatch and the actual desired signal steering vector, respectively. The optimization problem for finding the estimate $\hat{\mathbf{a}}$ can be written as [72]

$$\begin{aligned} \min_{\hat{\mathbf{a}}} \quad & \hat{\mathbf{a}}^H \hat{\mathbf{R}}^{-1} \hat{\mathbf{a}} \\ \text{s.t.} \quad & \mathbf{P}^\perp \hat{\mathbf{a}} = \mathbf{0}, \quad \|\hat{\mathbf{a}}\|^2 = M \\ & \hat{\mathbf{a}}^H \hat{\mathbf{C}} \hat{\mathbf{a}} \leq \mathbf{p}^H \mathbf{C} \mathbf{p} \end{aligned} \quad (36)$$

where $\hat{\mathbf{C}} \triangleq \int_{\hat{\Theta}} \mathbf{d}(\theta) \mathbf{d}^H(\theta) d\theta$ and the sector $\hat{\Theta}$ is the complement of the sector Θ . The last constraint in (36) limits the noise power collected in $\hat{\Theta}$. The optimization problem (36) is non-convex and, thus, it is modified in [72] so that the orthogonal component of δ could be estimated iteratively by solving a simpler convex problem. Here δ is decomposed to collinear and orthogonal components. The corresponding solution technique is called the sequential quadratic programming (SQP)-based RAB.

It is interesting, however, that the steering vector estimation problem (36) can be expressed as a quadratically constrained quadratic programming (QCQP) problem that makes it possible to find a much simpler solution than the SQP-based RAB of [72]. Let us first find the set of vectors satisfying the constraint $\mathbf{P}^\perp \hat{\mathbf{a}} = 0$.

Note that $\mathbf{P}^\perp \hat{\mathbf{a}} = 0$ implies that $\hat{\mathbf{a}} = \mathbf{U}\mathbf{U}^H \hat{\mathbf{a}}$ and, therefore, we can write that $\hat{\mathbf{a}} = \mathbf{U}\mathbf{b}$, where \mathbf{b} is an $L \times 1$ complex valued vector. Using the latter expression for $\hat{\mathbf{a}}$, the optimization problem (36) for estimating the steering vector can be equivalently rewritten in terms of \mathbf{b} as [75]

$$\begin{aligned} \min_{\mathbf{b}} \quad & \mathbf{b}^H \mathbf{U}^H \hat{\mathbf{R}}^{-1} \mathbf{U} \mathbf{b} \\ \text{s.t.} \quad & \|\mathbf{b}\|^2 = M \\ & \mathbf{b}^H \mathbf{U}^H \hat{\mathbf{C}} \mathbf{U} \mathbf{b} \leq \mathbf{p}^H \hat{\mathbf{C}} \mathbf{p} \end{aligned} \quad (37)$$

which is a QCQP problem.

It can be seen that the prior information used in this MVDR RAB design principle is the presumed steering vector and the angular sector Θ in which the desired source is located. Note that if the constraint (35) is replaced by the constraint $\|\delta\| \leq \varepsilon$ used in the worst-case optimization-based MVDR RAB design principle, the convergence to an interference steering vector will also be avoided, but the design principle becomes equivalent to that of the worst-case optimization-based MVDR RAB design principle (see also [67]). Techniques obtained based on this design principle can be further simplified for more structured uncertainties, for example, when it is known that the array is partially calibrated [73]. However, the amount of prior information about the uncertainty then increases. It brings us to the last design principle that is motivated by the wish to use as little as possible prior information, while still ensuring the robustness.

2.16. MVDR RAB design principle based on steering vector estimation with as little as possible prior information

In essence, the robustness can be practically viewed as an ability of adaptive beamformer to achieve acceptably high output SINR despite imprecise and perhaps very limited prior information. The following MVDR RAB design principle aims at fulfilling such most general notion of robustness. Assume that the desired source lies in the known angular sector $\Theta = [\theta_{\min}, \theta_{\max}]$ that is distinguishable from general locations of the interfering signals. The estimate $\hat{\mathbf{a}}$ can be forced not to converge to any vector with DOAs within the complement of Θ including the interference steering vectors and their linear combinations by the means of the following constraint [75]:

$$\hat{\mathbf{a}}^H \hat{\mathbf{C}} \hat{\mathbf{a}} \leq \Delta_0 \quad (38)$$

where Δ_0 is a uniquely selected value for a given angular sector Θ , that is,

$$\Delta_0 \triangleq \max_{\theta \in \Theta} \mathbf{d}^H(\theta) \hat{\mathbf{C}} \mathbf{d}(\theta). \quad (39)$$

It is worth stressing that no restrictions/assumptions on the structure of the interferences are needed. Moreover, the interferences do not need to have the same structure as the desired signal.

In order to illustrate how the quadratic constraint (38) works, let us consider a ULA of 10 omni-directional antenna elements spaced half wavelength apart from each other. Let the range of the desired signal angular locations be $\Theta = [0^\circ, 10^\circ]$. Fig. 1 depicts the values of the

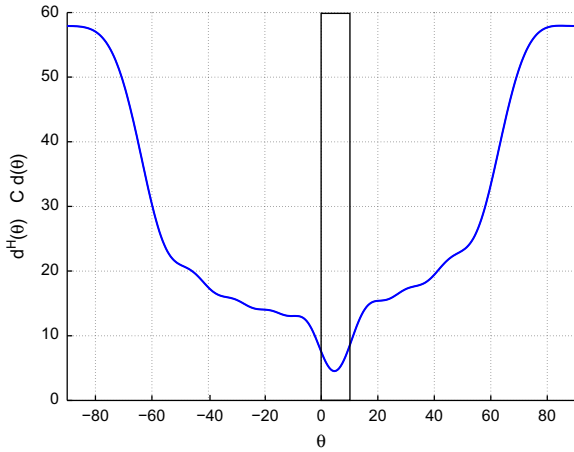

Fig. 1. Values of the term $\mathbf{d}^H(\theta)\tilde{\mathbf{C}}\mathbf{d}(\theta)$ in the constraint (38) for different angles.

quadratic term $\mathbf{d}^H(\theta)\tilde{\mathbf{C}}\mathbf{d}(\theta)$ for different angles. The rectangular bar in the figure marks the directions within the angular sector Θ . It can be observed from this figure that the term $\mathbf{d}^H(\theta)\tilde{\mathbf{C}}\mathbf{d}(\theta)$ takes the smallest values within the angular sector Θ and increases outside of the sector. Therefore, if Δ_0 is selected to be equal to the maximum value of the term $\mathbf{d}^H(\theta)\tilde{\mathbf{C}}\mathbf{d}(\theta)$ within the angular sector Θ , the constraint (38) guarantees that the estimate of the desired signal steering vector does not converge to any of the interference steering vectors and their linear combinations. The equality $\mathbf{d}^H(\theta)\tilde{\mathbf{C}}\mathbf{d}(\theta) = \Delta_0$ must occur at one of the edges of Θ . However, the value of the quadratic term might be smaller than Δ_0 at the other edge of Θ . Therefore, a possibly larger sector $\Theta_a \geq \Theta$ has to be defined, at which the equality $\mathbf{d}^H(\theta)\tilde{\mathbf{C}}\mathbf{d}(\theta) = \Delta_0$ holds at both edges.

Although for computing the matrix $\tilde{\mathbf{C}}$, the presumed knowledge of the antenna array geometry is used, an inaccurate information about the antenna array geometry is sufficient. It further stresses on the robustness of such beamforming design principle to the imperfect prior information [74]. Taking into account the desired signal steering vector normalization constraint and the constraint (38), the problem of estimating the desired signal steering vector based on the knowledge of the sector Θ can be formulated as the following optimization problem:

$$\begin{aligned} \min_{\hat{\mathbf{a}}} \quad & \hat{\mathbf{a}}^H \hat{\mathbf{R}}^{-1} \hat{\mathbf{a}} \\ \text{s.t.} \quad & \|\hat{\mathbf{a}}\|^2 = M \\ & \hat{\mathbf{a}}^H \tilde{\mathbf{C}} \hat{\mathbf{a}} \leq \Delta_0. \end{aligned} \quad (40)$$

Compared to the other MVDR RAB design principles, which require the knowledge of the presumed steering vector and, thus, the knowledge of the presumed antenna array geometry, propagation media, and source characteristics, only imprecise knowledge of the antenna array geometry and of the angular sector Θ are needed for the RAB (40).

Compared to the SQP-based beamformer, where the constraint $\mathbf{P}^+ \hat{\mathbf{a}} = \mathbf{0}$ enforces the estimated steering vector

to be a linear combination of T dominant eigenvectors \mathbf{U} , the steering vector in (40) is not restricted by such linear combination requirement, while the convergence to any of the interference steering vectors and their linear combinations is avoided by means of the constraint (38). As a result, the beamformer (40) has more degrees of freedom compared to the SQP-based beamformer. Thus, it is expected that it outperforms the latter one. Finally, due to the non-convex equality constraint, the problem (40) is non-convex and NP-hard in general. The efficient polynomial-time solution to this problem is developed in [75] based on the semi-definite programming relaxation theory [92–94].

In addition, the solution of the problem (37) leads to a better performance for RAB compared to that of the other techniques designed based on other principles, particularly, the worst-case optimization-based and outage probability constrained MVDR RAB design principles. This performance improvement is the result of forming the beam toward a single corrected steering vector yielding maximum output power, while the worst-case type of methods maximize the output power for all steering vectors in its uncertainty set. Thus, despite a significantly more relaxed assumptions on the prior information, the performance of the MVDR RAB design based on (40) is expected to be superior to that of the other RAB techniques designed according to other principles.

2.17. Comparison between MVDR RAB design principles

To compare a number of aforementioned MVDR RAB design principles, the following example is considered. A ULA of 10 omni-directional sensors with the inter-element spacing of half wavelength is used. Additive noise in antenna elements is modeled as spatially and temporally independent complex Gaussian noise with zero mean and unit variance. Two interfering sources are assumed to impinge on the antenna array from the directions 30° and 50° , while the presumed direction towards the desired signal is assumed to be 3° . The INR equals 30 dB and the desired signal is always present in the training data that contain $K=30$ samples. The desired signal steering vector is distorted by local scattering effect so that the actual steering vector is formed by five signal paths as $\mathbf{a} = \mathbf{p} + \sum_{i=1}^4 e^{j\psi_i} \mathbf{b}(\theta_i)$ where \mathbf{p} corresponds to the direct path and $\mathbf{b}(\theta_i)$, $i=1,2,3,4$ correspond to the coherently scattered paths. The i th path $\mathbf{b}(\theta_i)$ is modeled as a plane wave impinging on the antenna array from the direction θ_i . The angles θ_i , $i=1,2,3,4$ are independently drawn in each simulation run from a uniform random generator with mean 3° and standard deviation 1° . The parameters ψ_i , $i=1,2,3,4$ represent path phases that are independently and uniformly drawn from the interval $[0,2\pi]$ in each simulation run. Note that θ_i and ψ_i , $i=1,2,3,4$ change from run to run but do not change from snapshot to snapshot. Moreover, the antenna elements are assumed to be displaced. The difference between the presumed and actual positions of each antenna element is modeled as a uniform random variable distributed in the interval $[-0.05,0.05]$ measured in wavelength.

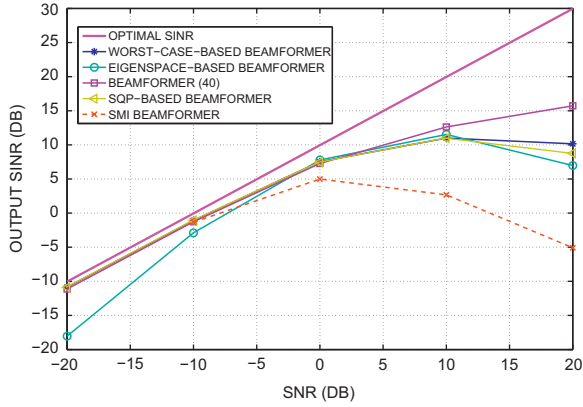

Fig. 2. Output SINR versus SNR for training data size of $K=30$ and $INR=30$ dB for the case of perturbations in antenna array geometry.

The RAB of (40) is compared with the eigenspace-based, the worst-case optimization-based, the SQP-based, and the LSMI RAB techniques. For the beamformer (40) and the SQP-based one, the angular sector of interest Θ is assumed to be $\Theta = [\theta_p - 5^\circ, \theta_p + 5^\circ]$ where θ_p is the presumed DOA of the desired signal. The value $\delta = 0.1$ and 8 dominant eigenvectors of the matrix \mathbf{C} are used in the SQP-based beamformer and the value $\varepsilon = 0.3$ M is used for the worst-case optimization-based beamformer. The dimension of the signal-plus-interference subspace is assumed to be always estimated correctly for the eigenspace-based beamformer. Diagonal loading factor of the SMI beamformer is selected as twice the noise power as recommended in [53].

Fig. 2 depicts the output SINR performance of the aforementioned RAB techniques tested versus the SNR. As it can be observed from the figure, the beamformer (40) has a better performance even if there is an error in the knowledge of the antenna array geometry.

3. Extensions to general-rank and broadband sources

3.1. General-rank signal model

In the case of general-rank desired signal, the desired signal can no longer be presented as in (2). Then, the SINR expression also changes as

$$\text{SINR} = \frac{\mathbf{w}^H \mathbf{R}_s \mathbf{w}}{\mathbf{w}^H \mathbf{R}_{i+n} \mathbf{w}} \quad (41)$$

where \mathbf{R}_s is the covariance matrix of the general-rank source that is no longer a rank one matrix as in the case of a point source. Typically, the desired signal is modeled as a spatially distributed source with some central angle and angular spread. The source covariance matrix is, therefore, no longer a rank-one matrix and, for example, in the incoherently scattered source case is given as [17]:

$\mathbf{R}_s = \int_{-\pi/2}^{\pi/2} \rho(\theta) \mathbf{a}(\theta) \mathbf{a}^H(\theta) d\theta$, where $\rho(\theta)$ is the normalized angular power density (i.e., $\int_{-\pi/2}^{\pi/2} \rho(\theta) d\theta = 1$). The name ‘general rank source’ is reflecting the fact that the desired signal covariance matrix can have any rank from 1 in a degenerate case to M .

3.2. Adaptive beamforming for general-rank source

In the case of general-rank source, the SINR expression (41) is the one that has to be used. The corresponding MVDR-type optimization problem can be then formulated as

$$\min_{\mathbf{w}} \mathbf{w}^H \mathbf{R}_{i+n} \mathbf{w} \quad \text{s.t.} \quad \mathbf{w}^H \mathbf{R}_s \mathbf{w} = 1. \quad (42)$$

The solution of the optimization problem (42) is well known to be given by the following generalized eigenvalue problem:

$$\mathbf{R}_{i+n} \mathbf{w} = \lambda \mathbf{R}_s \mathbf{w} \quad (43)$$

where λ is a generalized eigenvalue. Then the solution is the generalized eigenvector corresponding to the smallest generalized eigenvalue of the matrix pencil $\{\mathbf{R}_{i+n}, \mathbf{R}_s\}$.

Multiplying (43) by \mathbf{R}_{i+n}^{-1} , this equation can be rewritten as $\mathbf{R}_{i+n}^{-1} \mathbf{R}_s \mathbf{w} = (1/\lambda) \mathbf{w}$, which is the characteristic equation of the matrix $\mathbf{R}_{i+n}^{-1} \mathbf{R}_s$. The minimum generalized eigenvalue λ_{\min} in (43) corresponds to the maximum eigenvalue $1/\lambda_{\min}$ in the characteristic equation $\mathbf{R}_{i+n}^{-1} \mathbf{R}_s \mathbf{w} = (1/\lambda) \mathbf{w}$. Then the optimum beamforming vector can be written as

$$\mathbf{w}_{\text{opt}} = \mathcal{P}\{\mathbf{R}_{i+n}^{-1} \mathbf{R}_s\} \quad (44)$$

where $\mathcal{P}\{\cdot\}$ denotes the operator that computes the principal eigenvector of a matrix. The solution (44) is of a limited practical use because in most applications, the matrix \mathbf{R}_s is unknown, and often no reasonable estimate of it is available. However, if the estimate of \mathbf{R}_s is available as well as the estimate of \mathbf{R}_{i+n} , (44) provides a simple solution to the adaptive beamforming problem for the general-rank source. The solution of (42) can be equivalently found as the solution of the characteristic equation for the matrix $\mathbf{R}_s^{-1} \mathbf{R}_{i+n}$, that is, $\mathbf{R}_s^{-1} \mathbf{R}_{i+n} \mathbf{w} = \lambda \mathbf{w}$, if the matrix \mathbf{R}_s is full-rank invertible. In practice, however, the rank of the desired source can be smaller than the number of sensors in the antenna array and the source covariance matrix \mathbf{R}_s may not be invertible, while the matrix \mathbf{R}_{i+n} is guaranteed to be invertible due to the presence of the noise component. Therefore, the solution (44) is always preferred practically.

3.3. RAB for general-rank source

RAB techniques for general-rank signal model address the situation when the desired signal covariance matrix \mathbf{R}_s is not known precisely as well as the sample estimate of the data covariance matrix (7) is inaccurate because of small sample size.

In order to provide robustness against the norm-bounded mismatches $\|\Delta_1\| \leq \epsilon$ and $\|\Delta_2\| \leq \gamma$ (where ϵ and γ are some preselected bounds) in the desired signal and data sample covariance matrices, respectively, the worst-case optimization-based MVDR RAB design principle has been extended and the following solution has been derived [61,76]:

$$\mathbf{w} = \mathcal{P}\{(\hat{\mathbf{R}} + \gamma \mathbf{I})^{-1} (\mathbf{R}_s - \epsilon \mathbf{I})\}. \quad (45)$$

Although it is a simple closed-form solution, it is overly conservative due to the fact that the negatively diagonally loaded signal covariance matrix can be indefinite. A less

conservative RAB problem formulation, which enforces the matrix $\mathbf{R}_s + \Delta_1$ to be positive semi-definite has been considered in [77]. Defining $\mathbf{R}_s = \mathbf{Q}^H \mathbf{Q}$, which is, for example, the Cholesky decomposition, the corresponding RAB problem for a norm bounded-mismatch $\|\Delta\| \leq \eta$ (where η is some bound value found based on the bound value ϵ) to the matrix \mathbf{Q} is given as [77]

$$\begin{aligned} \min_{\mathbf{w}} \quad & \max_{\|\Delta_2\| \leq \gamma} \mathbf{w}^H (\hat{\mathbf{R}} + \Delta_2) \mathbf{w} \\ \text{s.t.} \quad & \min_{\|\Delta\| \leq \eta} \mathbf{w}^H (\mathbf{Q} + \Delta)^H (\mathbf{Q} + \Delta) \mathbf{w} \geq 1. \end{aligned} \quad (46)$$

If the mismatch of the signal covariance matrix is small enough, the optimization problem (46) can be equivalently recast as

$$\begin{aligned} \min_{\mathbf{w}} \quad & \mathbf{w}^H (\hat{\mathbf{R}} + \gamma \mathbf{I}) \mathbf{w} \\ \text{s.t.} \quad & \|\mathbf{Q} \mathbf{w}\| - \eta \|\mathbf{w}\| \geq 1. \end{aligned} \quad (47)$$

Due to the non-convex (difference-of-convex functions) constraint, the problem (47) is non-convex. Although the difference-of-convex functions (DC) programming problems are believed to be NP-hard in general, the problem (47) is shown to have very efficient polynomial-time solution [78,79] by applying the polynomial-time DC (POTDC) method [95].

3.4. Broadband signal model

In the broadband case, the desired signal and/or the interference signals is widely spread in the frequency domain. As a result, it is not possible to factorize the processing in temporal and spatial parts. Therefore, joint space-time adaptive processing (STAP) has to be performed.

Let the number of taps in the time domain be denoted as P . Let also the M array sensors be uniformly spaced with the inter-element spacing less than or equal to $c/2f_u$, where $f_u = f_c + B_s/2$ is the maximum frequency of the desired signal/maximum passband frequency, f_c is the carrier frequency, B_s is the signal bandwidth, and c is the wave propagation speed. The received signal at the i th sensor goes to a broadband presteering delay filter with the delay Δ_i . Let the output of the broadband presteering delay filter be sampled with the sampling frequency $f_s = 1/\tau$ where τ is the sampling time and f_s is greater than or equal to $2f_u$. Then the $MP \times 1$ stacked snapshot vector containing P delayed presteered data vectors is the data vector $\mathbf{x}(k)$. The beamformer output $y(k)$ is then given as: $y(k) = \mathbf{w}^T \mathbf{x}(k)$ where \mathbf{w} is the real-valued $MP \times 1$ beamformer weight vector, i.e., $w_{M(p-1)+m} = w_{m,p}$. The above described modeling is shown schematically in Fig. 3.

In the broadband case, the steering vector also depends on frequency and is given as $\mathbf{a}(f, \theta) = [e^{j2\pi f z_1 \sin(\theta)/c}, \dots, e^{j2\pi f z_M \sin(\theta)/c}]^T$ where z_i is the i th sensor location. The overall $MP \times 1$ steering vector can be expressed as $\bar{\mathbf{a}}(f, \theta) = \mathbf{d}(f) \otimes (\mathbf{B}(f) \mathbf{a}(f, \theta))$, where $\mathbf{d}(f) \triangleq [1, e^{-j2\pi f \tau}, \dots, e^{-j2\pi f (P-1)\tau}]^T$, $\mathbf{B}(f) \triangleq \text{diag}\{e^{-j2\pi f \Delta_1}, \dots, e^{-j2\pi f \Delta_M}\}$, and \otimes denotes the Kronecker product. Then the array response to a plane wave with the frequency f and angle of arrival θ is $H(f, \theta) = \mathbf{w}^T \bar{\mathbf{a}}(f, \theta)$.

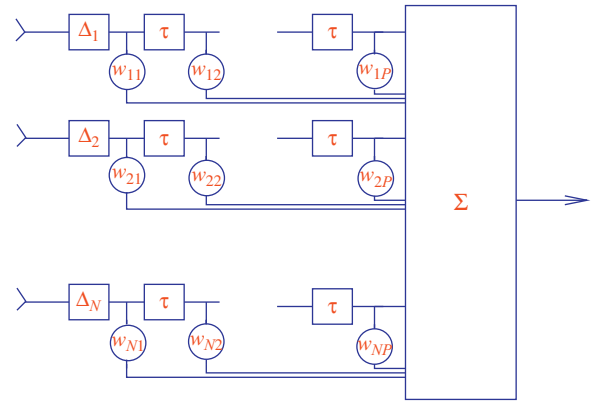

Fig. 3. Block scheme of the presteered broadband adaptive beamformer.

The presteering delays are selected so that the desired signal arriving from the look direction θ_0 appears coherently at the output of the M presteering filters so that [3]

$$\mathbf{B}(f) \mathbf{a}(f, \theta_0) = \mathbf{1}_M \quad (48)$$

where $\mathbf{1}_M$ is the $M \times 1$ vector containing all ones. Then the steering vector towards the look direction θ_0 becomes

$$\bar{\mathbf{a}}(f, \theta_0) = \mathbf{d}(f) \otimes \mathbf{1}_M \quad (49)$$

and the array response towards such signal becomes

$$H(f, \theta_0) = \mathbf{w}^T \bar{\mathbf{a}}(f, \theta_0) = \mathbf{w}^T \mathbf{C}_0 \mathbf{d}(f) \quad (50)$$

where $\mathbf{C}_0 \triangleq \mathbf{I}_P \otimes \mathbf{1}_M$.

3.5. Broadband beamforming

One popular approach to broadband beamforming is to decompose the baseband waveforms into narrowband frequency components by means of fast Fourier transform (FFT) [81,96]. Subsequently, the subbands can be processed independently from each other using narrowband beamforming techniques as it is shown in Fig. 4. Then any of the above discussed adaptive beamforming methods can be used to solve each narrowband beamforming problem. Thus, P adaptive beamforming problems, each for the beamforming vector of length M , are needed to be solved. The time-domain beamformer output samples are obtained by applying an inverse FFT (IFFT) of the output samples of the individual narrowband beamformers. However, such FFT-based broadband beamforming technique is non-optimum, since correlations between the frequency domain snapshot vectors of different subbands are not taken into account. Although these correlations can be reduced by increasing the FFT length, the latter requires a larger training data set [96].

Based on the broadband data and beamforming models, another approach to broadband beamforming that does not require subband decomposition exists [3]. The block scheme of such adaptive beamformer is shown in Fig. 3. This beamformer uses a presteering delay front-end consisting of presteering delay filters to time-align the desired signal components in different sensors. Then the

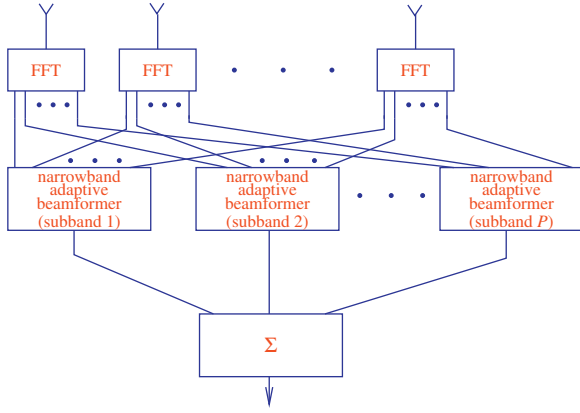

Fig. 4. Subband processing scheme for broadband adaptive beamforming.

presteering delays are followed by finite impulse response (FIR) filters, each of length P . The beamformer output is then the sum of the filtered waveforms. The weights of such spatial-temporal filter for the broadband MVDR beamformer are designed to minimize the output power subject to the distortionless response constraint for the desired signal. Multiple mainbeam constraints are required to protect the desired signal in the frequency band of interest. The distortionless response constraint is formulated for the steering vector (49) after the desired signal components in different sensors are made identical at the presteering stage. Then the narrowband adaptive beamforming algorithms can be extended relatively straightforwardly for the STAP shown in Fig. 3. Moreover, the GSC design principle can be straightforwardly used [3].

3.6. Broadband RAB

In the broadband case (see Fig. 3), the desired signal components at different frequencies are typically not perfectly phased-aligned by the presteering delays because of multiple practical imperfections. The reasons for imperfections are accentually the same as in the narrowband case with an addition of more error sources such as the presteering delay quantization effects. Therefore, there are errors that can be modeled in terms of the phase error vector $\delta(f)$ that is the function of the frequency f . Then the actual components of the desired signal arriving from DOA θ_s after the presteering delay filter are [80]

$$\mathbf{B}(f)\mathbf{a}(f, \theta_s) = e^{j\pi f \zeta} \mathbf{1}_M + \delta(f) \quad \forall f \in [f_l, f_u] \quad (51)$$

instead of (48) in the case of no mismatch. Here ζ is a common time delay at each of the M sensors and f_l is the minimum frequency of the desired signal.

Defining the mismatch set that contains all possible phase error vectors at the frequency f as $\mathcal{A}_\varepsilon(f) \triangleq \{\delta(f) \in \mathbb{C}^M \mid \|\delta(f)\| \leq \varepsilon(f)\}$, the broadband RAB problem can be written as

$$\min_{\delta(f) \in \mathcal{A}_\varepsilon(f)} |H(f, \theta_s)| \geq 1 \quad \forall f \in [f_l, f_u]. \quad (52)$$

Using (50) and (51), the array response towards DOA θ_s can be written as [80]

$$H(f, \theta_s) = e^{j\pi f \zeta} \mathbf{w}^T \mathbf{C}_0 \mathbf{d}(f) + \mathbf{w}^T \mathbf{Q}(f) \delta(f) \quad (53)$$

where $\mathbf{Q}(f) \triangleq \mathbf{d}(f) \otimes \mathbf{I}_M$ is $MP \times M$ matrix.

Using the triangular and then Cauchy–Schwarz inequalities, the magnitude of the lower bound for the array response (53) can be found as

$$\begin{aligned} |H(f, \theta_s)| &= |e^{j\pi f \zeta} \mathbf{w}^T \mathbf{C}_0 \mathbf{d}(f) + \mathbf{w}^T \mathbf{Q}(f) \delta(f)| \\ &\geq |\mathbf{w}^T \mathbf{C}_0 \mathbf{d}(f)| - |\mathbf{w}^T \mathbf{Q}(f) \delta(f)| \\ &\geq |\mathbf{w}^T \mathbf{C}_0 \mathbf{d}(f)| - \varepsilon(f) \|\mathbf{Q}^T(f) \mathbf{w}\|. \end{aligned} \quad (54)$$

Finally, using the lower bound (54) for the constraint $|H(f, \theta_s)| \geq 1$ in (52) and imposing a linear phase constraint on each of the M FIR filters of the array processor, Fig. 3, the optimization problem (52) can be reformulated as the following worst-case robust MVDR optimization problem:

$$\begin{aligned} \min_{\mathbf{w}} \quad & \mathbf{w}^T \mathbf{R} \mathbf{w} \\ \text{s.t.} \quad & |\mathbf{w}^T \mathbf{C}_0 \mathbf{d}(f)| - \varepsilon(f) \|\mathbf{Q}^T(f) \mathbf{w}\| \geq 1, \quad f \in [f_l, f_u] \\ & w_{m,l} = w_{m,p-l+1} \quad \forall m \in \mathbb{Z}_1^M, \quad l \in \mathbb{Z}_1^{P-l-1} \end{aligned} \quad (55)$$

where \mathbf{R} is the covariance matrix of the stacked snapshot vectors, $P_c = (P+1)/2$, and \mathbb{Z}_i^j denotes the ring of integers from i to j . The last constraint in the optimization problem (55) ensures the linear phase at each of the M FIR filters and it provides additional robustness against presteering errors [80]. The problem (55) is non-convex, but it can be reformulated as a convex problem that can be solved efficiently [80]. The disadvantage is, however, that the constraint on the magnitude of the array response is strengthened by using the triangular and Cauchy–Schwarz inequalities (see (54)). More sophisticated broadband RAB designs can be found, for example, in [83].

4. Conclusion

The basic principles of MVDR RAB design have been summarized based on the example of narrowband point source. The extensions of some design principles to general-rank and broadband desired signal have also been given. Many (other than summarized in this tutorial) more particular MVDR RAB techniques which use more specific notions of robustness and are based on more specific assumptions on the available prior information have been designed based on the revised MVDR RAB design principles. The area of RAB remains to be an exciting field of research and this tutorial is anticipated to be constructive for further developments in the field.

References

- [1] A.B. Gershman, Robust adaptive beamforming in sensor arrays, *International Journal of Electronics and Communications* 53 (December) (1999) 305–314. (invited paper).
- [2] A.B. Gershman, N.D. Sidiropoulos, S. Shahbazpanahi, M. Bengtsson, B. Ottersten, Convex optimization-based beamforming, *IEEE Signal Processing Magazine* 27 (June (3)) (2010) 62–75.
- [3] O.L. Frost, An algorithm for linearly constrained adaptive array processing, *Proceedings of the IEEE* 60 (1972) 926–935.

- [4] N.K. Jablon, Adaptive beamforming with the generalized sidelobe canceller in the presence of array imperfections, *IEEE Transactions on Antennas and Propagation* 34 (1986) 996–1012.
- [5] J.C. Preisig, Robust maximum energy adaptive matched field processing, *IEEE Transactions on Signal Processing* 42 (1994) 1585–1593.
- [6] D.D. Feldman, L.J. Griffiths, A projection approach to robust adaptive beamforming, *IEEE Transactions on Signal Processing* 42 (April) (1994) 867–876.
- [7] J.L. Yu, C.C. Yeh, Generalized eigenspace-based beamformers, *IEEE Transactions on Signal Processing* 43 (1995) 2453–2461.
- [8] U. Nickel, On the application of subspace methods for small sample size, *International Journal of Electronics and Communications* 51 (1997) 279–289.
- [9] E.K. Hung, R.M. Turner, A fast beamforming algorithm for large arrays, *IEEE Transactions on Aerospace and Electronic Systems* 19 (July) (1983) 598–607.
- [10] A.B. Gershman, G.V. Serebryakov, J.F. Boehme, Constrained Hung-Turner adaptive beamforming algorithm with additional robustness to wideband and moving jammers, *IEEE Transactions on Antennas and Propagation* 44 (1996) 361–367.
- [11] C.H. Gierull, Performance analysis of fast projections of the Hung-Turner type for adaptive beamforming, *Signal Processing* 50 (1996) 17–28.
- [12] T.J. Shan, T. Kailath, Adaptive beamforming for coherent signals and interference, *IEEE Transactions on Acoustics, Speech, and Signal Processing* 33 (1985) 527–536.
- [13] M.D. Zoltowski, On the performance of the MVDR beamformer in the presence of correlated interference, *IEEE Transactions on Acoustics, Speech, and Signal Processing* 36 (1988) 945–947.
- [14] A.B. Gershman, V.T. Ermolaev, Optimal subarray size for spatial smoothing, *IEEE Signal Processing Letters* 2 (1995) 28–30.
- [15] R.T. Williams, S. Prasad, A.K. Mahalanabis, L. Sibul, An improved spatial smoothing technique for bearing estimation in a multipath environment, *IEEE Transactions on Acoustics, Speech, and Signal Processing* 36 (1988) 425–432.
- [16] K. Takao, N. Kikuma, T. Yano, Toeplitzization of correlation matrix in multipath environment, in: *Proceedings of the ICASSP'86, Tokyo, Japan, 1986*, pp. 1873–1876.
- [17] A.B. Gershman, C.F. Mecklenbraeucker, J.F. Boehme, Matrix fitting approach to direction of arrival estimation with imperfect spatial coherence of wavefronts, *IEEE Transactions on Signal Processing* 45 (1997) 1894–1899.
- [18] A.B. Gershman, V.I. Turchin, V.A. Zverev, Experimental results of localization of moving underwater signal by adaptive beamforming, *IEEE Transactions on Signal Processing* 43 (October) (1995) 2249–2257.
- [19] Y.J. Hong, C.C. Yeh, D.R. Ucci, The effect of a finite-distance signal source on a far-field steering Applebaum array – two dimensional array case, *IEEE Transactions on Antennas and Propagation* 36 (April) (1988) 468–475.
- [20] J. Goldberg, H. Messer, Inherent limitations in the localization of a coherently scattered source, *IEEE Transactions on Signal Processing* 46 (December) (1998) 3441–3444.
- [21] O. Besson, P. Stoica, Decoupled estimation of DOA and angular spread for a spatially distributed source, *IEEE Transactions on Signal Processing* 48 (July) (2000) 1872–1882.
- [22] D. Astely, B. Ottersten, The effects of local scattering on direction of arrival estimation with MUSIC, *IEEE Transactions on Signal Processing* 47 (December) (1999) 3220–3234.
- [23] R.J. Mallioux, Covariance matrix augmentation to produce adaptive array pattern troughs, *Electronic Letters* 31 (1995) 771–772.
- [24] A.B. Gershman, U. Nickel, J.F. Boehme, Adaptive beamforming algorithms with robustness against jammer motion, *IEEE Transactions on Signal Processing* 45 (1997) 1878–1885.
- [25] J.R. Guerci, Theory and application of covariance matrix tapers to robust adaptive beamforming, *IEEE Transactions on Signal Processing* 47 (April) (2000) 977–985.
- [26] M.A. Zatman, Comment on theory and application of covariance matrix tapers for robust adaptive beamforming, *IEEE Transactions on Signal Processing* 48 (June) (2000) 1796–1800.
- [27] S.D. Hayward, Adaptive beamforming for rapidly moving arrays, in: *Proceedings of the International Conference on Radar, Beijing, China, 1996*, pp. 546–549.
- [28] K. Takao, K. Komiyama, An adaptive antenna for rejection of wideband interference, *IEEE Transactions on Aerospace and Electronic Systems* 16 (1980) 452–459.
- [29] M. Bengtsson, B. Ottersten, Optimal and suboptimal transmit beamforming, in: L. Godara (Ed.), *Handbook of Antennas in Wireless Communications*, CRC Press, Boca Raton, FL, 2001. (Chapter 18).
- [30] S. Verdú, *Multiuser Detection*, Cambridge University Press, Cambridge, UK, 1998.
- [31] K. Zarifi, S. Shahbazpanahi, A.B. Gershman, Z.-Q. Luo, Robust blind multiuser detection based on the worst-case performance optimization of the MMSE receiver, *IEEE Transactions on Signal Processing* 53 (January) (2005) 295–305.
- [32] S.A. Vorobyov, Robust CDMA multiuser detectors: probability-constrained versus the worst-case based design, *IEEE Signal Processing Letters* 15 (2008) 273–276.
- [33] S. Shahbazpanahi, M. Beheshti, A.B. Gershman, M. Gharavi-Alkhansari, K.M. Wong, Minimum variance linear receivers for multi-access MIMO wireless systems with space-time block coding, *IEEE Transactions on Signal Processing* 52 (December) (2004) 3306–3313.
- [34] Y. Rong, S.A. Vorobyov, A.B. Gershman, Robust linear receivers for multi-access space-time block coded MIMO systems: A probabilistically constrained approach, *IEEE Journal of Selected Areas in Communications* 24 (August) (2006) 1560–1570.
- [35] N.D. Sidiropoulos, T.N. Davidson, Z.-Q. Luo, Transmit beamforming for physical-layer multicasting, *IEEE Transactions on Signal Processing* 54 (June) (2006) 2239–2251.
- [36] E. Karipidis, N.D. Sidiropoulos, Z.-Q. Luo, Far-field multicast beamforming for uniform linear antenna arrays, *IEEE Transactions on Signal Processing* 55 (October) (2007) 4916–4927.
- [37] K.T. Phan, S.A. Vorobyov, N.D. Sidiropoulos, C. Tellambura, Spectrum sharing in wireless networks via QoS-aware secondary multicast beamforming, *IEEE Transactions on Signal Processing* 57 (June) (2009) 2323–2335.
- [38] V. Havary-Nassab, S. Shahbazpanahi, A. Grami, Z.-Q. Luo, Distributed beamforming for relay networks based on second-order statistics of the channel state information, *IEEE Transactions on Signal Processing* 56 (September) (2008) 4306–4316.
- [39] B. Widrow, P.E. Mantej, J.L. Griffiths, B.B. Goode, Adaptive antenna systems, *Proceeding of the IEEE* 55 (December) (1967) 2143–2159.
- [40] R.A. Monzingo, T.W. Miller, *Introduction to Adaptive Arrays*, Wiley, NY, 1980.
- [41] B. Widrow, S.D. Stearns, *Adaptive Signal Processing*, Prentice Hall, Englewood Cliffs, NJ, 1985.
- [42] H.L. Van Trees, *Optimum Array Processing*, Wiley, NY, 2002.
- [43] S. Haykin, J. Litva, T. Shepherd (Eds.), *Radar Array Processing*, Springer-Verlag, 1992.
- [44] A. Farina, *Antenna-Based Signal Processing Techniques for Radar Systems*, Artech House, Norwood, MA, 1992.
- [45] R.J. Vaccaro (Ed.), The past, present, and the future of underwater acoustic signal processing, *IEEE Signal Processing Magazine* 15 (July) (1998) 21–51.
- [46] T.S. Rappaport (Ed.), *Smart Antennas: Adaptive Arrays, Algorithms, and Wireless Position Location*, IEEE Press, 1998.
- [47] A.B. Gershman, N.D. Sidiropoulos (Eds.), *Space-Time Processing for MIMO Communications*, John Wiley and Sons, 2005.
- [48] Y. Kameda, J. Ohga, Adaptive microphone-array system for noise reduction, *IEEE Transactions on Acoustics, Speech, and Signal Processing* 34 (December) (1986) 1391–1400.
- [49] S.W. Ellingson, G.A. Hampson, A subspace-tracking approach to interference nulling for phased array-based radio telescopes, *IEEE Transactions on Antennas and Propagation* 50 (January) (2002) 25–30.
- [50] A. Leshem, J. Christou, B.D. Jeffs, E. Kuruoglu, A.J. van der Veen (Eds.), Issue on signal processing for space research and astronomy, *IEEE Journal of Selected Topics in Signal Processing* 2(5, October) (2008).
- [51] K. Sekihara, Performance of an MEG adaptive beamformer source reconstruction technique in the presence of adaptive low-rank interference, *IEEE Transactions on Biomedical Engineering* 51 (January) (2004) 90–99.
- [52] K.-M. Chen, D. Misra, H. Wang, H.-R. Chuang, E. Postow, An X-band microwave life-detection system, *IEEE Transactions on Biomedical Engineering* 33 (July) (1986) 697–701.
- [53] H. Cox, R.M. Zeskind, M.H. Owen, Robust adaptive beamforming, *IEEE Transactions on Acoustic, Speech, and Signal Processing* 35 (October) (1987) 1365–1376.
- [54] Y.I. Abramovich, Controlled method for adaptive optimization of filters using the criterion of maximum SNR, *Radio Engineering and Electronic Physics* 26 (March) (1981) 87–95.
- [55] B.D. Carlson, Covariance matrix estimation errors and diagonal loading in adaptive arrays, *IEEE Transactions on Aerospace and Electronic Systems* 24 (July (7)) (1988) 397–401.
- [56] B. Widrow, K.M. Duvall, R.P. Gooch, W.C. Newman, Signal cancellation phenomena in adaptive antennas: causes and cures, *IEEE Transactions on Antennas and Propagation* 30 (1982) 469–478.

- [57] J.W. Kim, C.K. Un, An adaptive array robust to beam pointing error, *IEEE Transactions on Signal Processing* 40 (June) (1992) 1582–1584.
- [58] L. Chang, C.C. Yeh, Performance of DMI and eigenspace-based beamformers, *IEEE Transactions on Antennas and Propagation* 40 (November) (1992) 1336–1347.
- [59] S.A. Vorobyov, A.B. Gershman, Z.-Q. Luo, Robust adaptive beamforming using worst-case performance optimization: a solution to the signal mismatch problem, *IEEE Transactions on Signal Processing* 51 (February) (2003) 313–324.
- [60] R.G. Lorenz, S.P. Boyd, Robust minimum variance beamforming, *IEEE Transactions on Signal Processing* 53 (May) (2005) 1684–1696.
- [61] A.B. Gershman, Z.-Q. Luo, S. Shahbazpanahi, Robust adaptive beamforming based on worst-case performance optimization in: P. Stoica, J. Li (Eds.), *Robust Adaptive Beamforming*, Wiley, Hoboken, NJ, 2006, pp. 49–89.
- [62] G.A. Fabrizio, A.B. Gershman, M.D. Turley, Robust adaptive beamforming for HF surface wave over-the-horizon radar, *IEEE Transactions on Aerospace and Electronic Systems* 40 (April) (2004) 510–625.
- [63] J. Li, P. Stoica, Z. Wang, On robust Capon beamforming and diagonal loading, *IEEE Transactions on Signal Processing* 51 (July) (2003) 1702–1715.
- [64] S.A. Vorobyov, A.B. Gershman, Z.-Q. Luo, N. Ma, Adaptive beamforming with joint robustness against mismatched signal steering vector and interference nonstationarity, *IEEE Signal Processing Letters* 11 (February) (2004) 108–111.
- [65] J. Li, P. Stoica (Eds.), *Robust Adaptive Beamforming*, John Wiley and Sons, New York, NY, 2005.
- [66] P. Stoica, Z. Wang, J. Li, Robust Capon beamforming, *IEEE Signal Processing Letters* 10 (June (6)) (2003) 172–175.
- [67] J. Li, P. Stoica, Z. Wang, Doubly constrained robust capon beamformer, *IEEE Transactions on Signal Processing* 52 (September) (2004) 2407–2423.
- [68] S.A. Vorobyov, H. Chen, A.B. Gershman, On the relationship between robust minimum variance beamformers with probabilistic and worst-case distortionless response constraints, *IEEE Transactions on Signal Processing* 56 (November) (2008) 5719–5724.
- [69] S.A. Vorobyov, A.B. Gershman, Y. Rong, On the relationship between the worst-case optimization-based and probability-constrained approaches to robust adaptive beamforming, in: *Proceedings of the 32nd IEEE International Conference on Acoustics, Speech, and Signal Processing*, Honolulu, Hawaii, USA, April 2007, pp. 977–980.
- [70] M. Ruebsamen, A.B. Gershman, Robust adaptive beamforming using multi-dimensional covariance fitting, *IEEE Transactions on Signal Processing* 60 (February) (2012) 740–753.
- [71] A. Pezeshki, B.D. Van Veen, L.L. Scharf, H. Cox, M. Lundberg, Eigenvalue beamforming using a multi-rank MVDR beamformer and subspace selection, *IEEE Transactions on Signal Processing* 56 (May) (2008) 1954–1967.
- [72] A. Hassani, S.A. Vorobyov, K.M. Wong, Robust adaptive beamforming using sequential programming: an iterative solution to the mismatch problem, *IEEE Signal Processing Letters* 15 (2008) 733–736.
- [73] L. Lei, J.P. Lie, A.B. Gershman, C.M.S. See, Robust adaptive beamforming in partly calibrated sparse sensor arrays, *IEEE Transactions on Signal Processing* 58 (March) (2010) 1661–1667.
- [74] A. Khabbazi, S.A. Vorobyov, A. Hassani, Robust adaptive beamforming via estimating steering vector based on semidefinite relaxation, in: *Proceedings of the 44th Asilomar Conference on Signals, Systems and Computers*, Pacific Grove, California, November 2010, pp. 1102–1106.
- [75] A. Khabbazi, S.A. Vorobyov, A. Hassani, Robust adaptive beamforming based on steering vector estimation with as little as possible prior information, *IEEE Transactions on Signal Processing* 60 (June) (2012) 2974–2987.
- [76] S. Shahbazpanahi, A.B. Gershman, Z.-Q. Luo, K.M. Wong, Robust adaptive beamforming for general-rank signal models, *IEEE Transactions on Signal Processing* 51 (September) (2003) 2257–2269.
- [77] H.H. Chen, A.B. Gershman, Robust adaptive beamforming for general-rank signal models with positive semi-definite constraints, in: *Proceedings of the IEEE International Conference on Acoustic, Speech, and Signal Processing*, Las Vegas, USA, April 2008, pp. 2341–2344.
- [78] A. Khabbazi, S.A. Vorobyov, A computationally efficient robust adaptive beamforming for general-rank signal model with positive semi-definite constraint, in: *Proceedings of the IEEE International Workshop on Computational Advances in Multi-Sensor Adaptive Processing*, San Juan, Puerto Rico, December 2011, pp. 185–188.
- [79] A. Khabbazi, S.A. Vorobyov, Robust adaptive beamforming for general-rank signal model with positive semi-definite constraint via POTDC, *IEEE Transactions on Signal Processing*, submitted for publication <<http://www.ece.ualberta.ca/~vorobyov/TPS13a.pdf>>.
- [80] A. El-Keyi, T. Kirubarajan, A.B. Gershman, Adaptive wideband beamforming with robustness against presteering errors, in: *Proceedings of the IEEE Workshop on Sensor Arrays and Multi-Channel Processing*, Waltham, MA, USA, July 2006, pp. 11–15.
- [81] Z. Wang, J. Li, P. Stoica, T. Nishida, M. Sheplak, Constant beamwidth and constant-powerwidth wideband robust Capon beamformers for acoustic imaging, *Journal of the Acoustical Society of America* 116 (3) (2004) 1621–1631.
- [82] M. Ruebsamen, *Advanced Direction-of-Arrival Estimation and Beamforming Techniques for Multiple Antenna Systems*, Ph.D. Thesis, Darmstadt University of Technology, 2011 (Chapter 5).
- [83] M. Ruebsamen, A. El-Keyi, A.B. Gershman, T. Kirubarajan, Robust broadband adaptive beamforming using convex optimization, in: D.P. Palomar, Y.C. Eldar (Eds.), *Convex Optimization in Signal Processing and Communications*, Cambridge University Press, 2010, pp. 315–339. (Chapter 9).
- [84] O. Leodit, M. Wolf, Improved estimation of the covariance matrix of the stock returns with an application to portfolio selection, *Journal of Empirical Finance* 10 (2003) 603–621.
- [85] Y. Gu, A. Leshem, Robust adaptive beam forming based on interference covariance matrix reconstruction and steering vector estimation, *IEEE Transactions on Signal Processing* 60 (July) (2012) 3881–3885.
- [86] I.S. Reed, J.D. Mallett, L.E. Brennan, Rapid convergence rate in adaptive arrays, *IEEE Transactions on Aerospace and Electronic Systems* 10 (November) (1974) 853–863.
- [87] L.C. Godara, The effect of phase-shift errors on the performance of an antenna-array beamformer, *IEEE Journal of Oceanic Engineering* 10 (July) (1985) 278–284.
- [88] Special issue on adaptive antennas, *IEEE Transactions on Antennas and Propagation*, 24 (1976).
- [89] A.N. Tikhonov, V.Y. Arsenin, *Solution to Ill-Posed Problems*, V.H. Winston, Washington, DC, 1977.
- [90] J.K. Thomas, L.L. Scharf, D.W. Tufts, The probability of a subspace swap in the SVD, *IEEE Transactions on Signal Processing* 43 (March) (1995) 730–736.
- [91] Z.-Q. Luo, W. Yu, An introduction to convex optimization for communications and signal processing, *IEEE Journal of Selected Areas in Communications* 24 (August) (2006) 20–34.
- [92] Z.-Q. Luo, W.-K. Ma, A.M.-C. So, Y. Ye, S. Zhang, Semidefinite relaxation of quadratic optimization problems, *IEEE Signal Processing Magazine* 27 (May (3)) (2010) 20–34.
- [93] Y.S. Nesterov, Semidefinite relaxation and nonconvex quadratic optimization, *Optimization Methods and Software* 9 (1–3) (1998) 141–160.
- [94] S. Zhang, Quadratic maximization and semidefinite relaxation, *Mathematics Programs A* 87 (2000) 453–465.
- [95] A. Khabbazi, F. Roemer, S.A. Vorobyov, M. Haardt, Sum-rate maximization in two-way AF MIMO relaying: polynomial time solutions to a class of DC programming problems, *IEEE Transactions on Signal Processing* 60 (October (10)) (2012) 5478–5493.
- [96] T.J. Cornwell, A novel principle for optimization of the instantaneous Fourier plane coverage of correlation arrays, *IEEE Transactions on Antennas and Propagation* 36 (8) (1988) 1165–1167.