

The 14th Symposium on Accelerator Science and Technology, Tsukuba, Japan, November 2003

## REPLACEMENT OF ACCELERATOR TUBES OF THE JAERI TANDEM ACCELERATOR WITH TUBES CLEANED BY A HIGH-PRESSURE WATER JET

S. Takeuchi, T. Nakanoya, H. Kabumoto, N. Ishizaki, M. Matsuda, Y. Tsukihashi, S. Kanda, H. Tayama, S. Abe and T. Yoshida

Japan Atomic Energy Research Institute, Tokai Research Establishment  
Tokai Naka Ibaraki 319-1195, Japan

### Abstract

In an effort of increasing the terminal voltage of the JAERI tandem accelerator by replacing the acceleration tubes with compressed geometry tubes, we investigated a high-pressure water-jet rinsing of tube insides. There were a lot of microscopic particles loosely bound on inside ceramic surfaces. The cleaning was found to be very effective to reduce discharge activities as a result of a 3 MV test. And then, the replacement was carried out.

### INTRODUCTION

The JAERI tandem accelerator has been running over 20 years. Its operating terminal voltage has been in a range of 16 MV these years, although it started at 18 MV in 1982 or the design voltage was 20 MV. We intended to improve the terminal voltage by replacing the 11 acceleration-gap tubes to 21 acceleration-gap *compressed geometry* tubes.

An addition of more acceleration tubes in place of useless heater plates done at ORNL was certainly effective[1]. But, we have to be careful to use new tubes because one often needs very lengthy conditioning to get rated voltages. We attribute the reason to pollution of tube inner surfaces. We believed that cleaning the pollution using a high-pressure water jet is effective to eliminate lengthy conditioning as it is popularly used for eliminating electron field emission in superconducting cavities[2,3]. It is very important for us to resume the machine time as soon as possible after the tube replacement.

We investigated how much the tube insides or ceramic insulator surfaces were polluted with dust or micro-particles and how much they were cleaned by the cleaning. Old and new tubes and their ceramics were compared in the investigation. We carried out a 3 MV test with new tubes for replacement at National Electrostatics Corp(NEC).

After a cleaning over six months, the tube replacement was carried out.

### CLEANING METHOD

An apparatus of high-pressure water jet spray, used for acceleration tubes, is illustrated in Fig. 1. Air of 1 MPa was fed to the nozzle to create two water jets. The jet speed was 250-300 m/s. The nozzle moved up and down,

the tube was rotated on a turn table and the two jets were tilted by  $\pm 15$  degrees, so that the tube inside with electrodes were cleaned thoroughly. The air was filtered

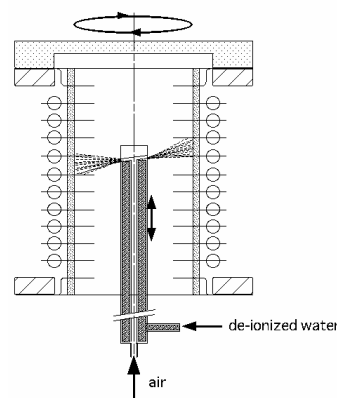

Fig. 1. High-pressure water jet spray nozzle for acceleration tubes

and warmed to 40 °C. The water was 15 - 18 M-ohm-cm de-ionised water passed through a 0.2  $\mu\text{m}$  filter. The spraying took about 25 minutes for a tube. After rinsing, the tube was dried at 50 °C in a clean booth. Cleaned tubes were baked and pumped at 200 °C for two weeks.

For more perfect cleaning, ultra-sonic wave cleaning was added as a pre-cleaning process.

### CLEANING EFFECTS

In order to know the cleaning effect of the high-pressure water jet spray, the high-pressure water jet sprayer was used without feeding water. Dry and filtered air jet was sprayed to the inner surfaces of a tube and particles in the air from the tube were counted by using a particle counter. The measurements were done with an old unused spare tube before and after a high-pressure water jet spray and with another one after putting in an ultrasonic wave bath for 30 minutes. As is presented in Fig.2, millions of particles came out from the unused tube and the numbers were reduced greatly by a high-pressure water jet rinse as well as ultrasonic wave cleaning.

## COMPARISON OF CERAMICS BETWEEN OLD AND NEW TUBES

### Grain size

From observations through a microscope, ceramic grains in the insulators were found to be very different between old and new tube ceramic insulator samples. The *old* ceramics contained a lot of grains as large as 40  $\mu\text{m}$  and the *new* ceramics had much fewer and covered with small grains. The mean values were 25  $\mu\text{m}$  and 14  $\mu\text{m}$ , respectively.

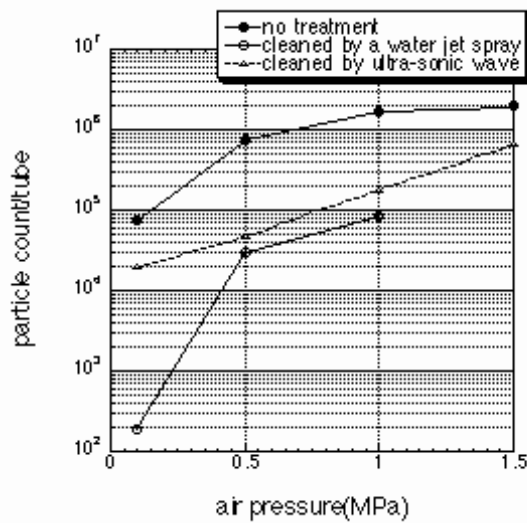

Fig.2 Particles which came out from the tubes sprayed by an air jet with increasing pressure before and after a high-pressure water jet spray and ultrasonic wave cleaning.

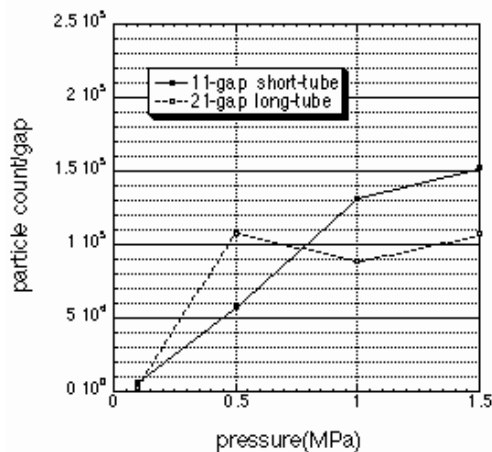

Fig. 3. Particles which came out from the old(11 gap tube) and new(21 gap compressed geometry tube) sprayed by an air jet with increasing pressure.

### Loosely bound particles

By spraying air jets, particles from old and new tubes were similarly measured as described in the previous section. The results are shown in Fig. 3. The new tube had

much more particles which came off easily at a low air pressure of 0.5 MPa than the old tube had. These loosely bound particles on surfaces must help discharge activities develop under a high voltage gradient. Loosely bound particles being hit by electrons are easily charged-up, create secondary electrons or jump out with full of charges into the vacuum space between electrodes, and result in a chain reaction of discharges. This result indicates that the cleaning is much more important for the new tubes than for the old ones.

### Electron feed-and-collection experiment

In order to know the interaction between electrons and ceramic surfaces under an electric field parallel to the surfaces, we carried out an experiment of feeding electrons (with an injection energy of 100 eV) to one edge of a ceramic sample, which was put between parallel electrodes, and collecting electrons, which flowed over the sample surface, at the other side of the sample. As shown in Fig. 4, nothing happened above a gap voltage of 1000V (the rated gap voltage in actual acceleration tubes is 30 kV) and a transition-like abrupt increase was observed at several hundred volts for each sample during a slow increase of the gap voltage. Such part was irreversible for a decreasing path. The abrupt increase seems to be a transition of electron multiplication factor from  $<1$  to  $>1$ . The transition voltages were high(380-400V) for the old ceramic surfaces with large grains and low(240-270V) for the new ones with small grains, and those were greatly lowered by a sand blast surface treatment and significantly recovered by high-pressure water jet rinsing (as  $\rightarrow 200-220\text{V} \rightarrow 260-280\text{V}, \rightarrow 160-180\text{V} \rightarrow 220-240\text{V}$ , respectively). This phenomenon must be due to loosely bound micro-particles on the surfaces. The transition voltage can be regarded as a barometer of surface cleanliness.

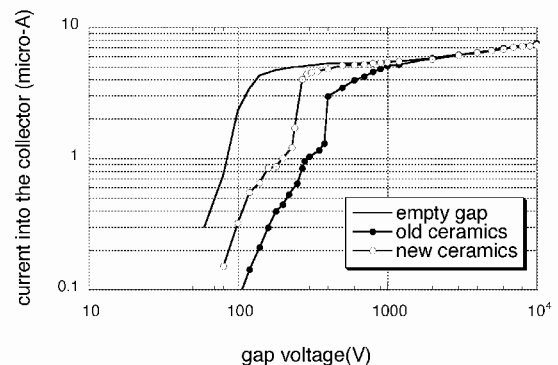

Fig. 4 Electron current into the collector as a function of gap voltage during 100eV electron feeding onto a ceramic sample set in a pair of electrodes.

## HIGH-VOLTAGE TEST RESULT

We carried out a 3 MV test with new tubes. Six of the new tubes for the tube replacement were cleaned with ultrasonic wave and high-pressure water jets and baked and sent to NEC for testing. NEC carried out the test

according to a contract. The chart during the test is shown in Fig. 5. The rated voltage of 3 MV was achieved only in 4 hours. There were only a few sparks in three days or over about 24 hours. The voltage reached at 3.2 MV without increasing charging current and became very stable after a small discharge.

For comparison, a chart of 3MV test for original new tubes before shipping from NEC is presented in Fig. 6. Frequent small discharges and sparks happened to the tubes at 2.6-2.8 MV. The voltage would not have increased by continuing the conditioning.

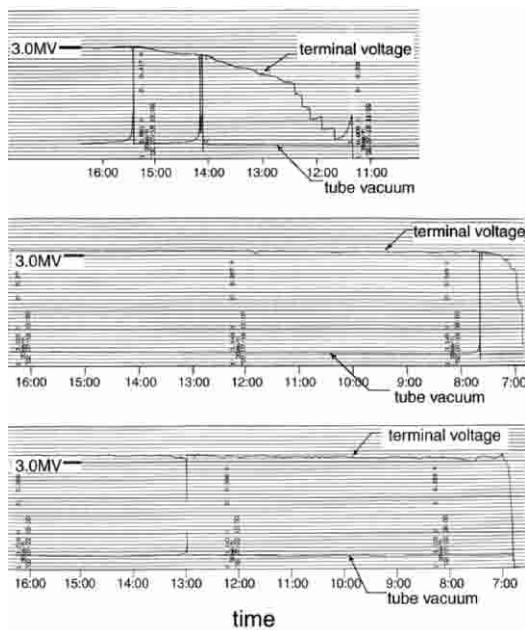

Fig. 5 Chart records during a 3 MV high voltage test with 6 new compressed geometry tubes after a high-pressure water jet treatment.

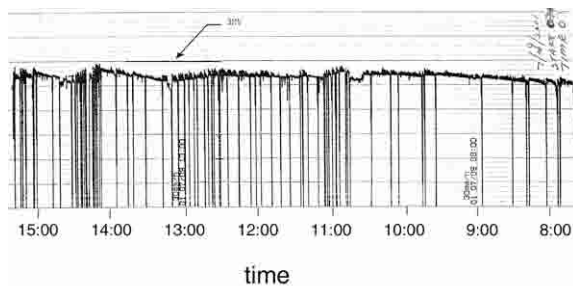

Fig. 6 Chart record of the high voltage during a 3 MV test with original new compressed geometry tubes.

There was a big reduction of 5-10  $\mu\text{A}$  to 0.4-2.1  $\mu\text{A}$  in the lost charge between before and after the cleaning. This reduction indicates that loose micro-particles were playing an important role of electron carriers in the tubes.

## TUBE REPLACEMENT

The tube replacement was executed after the investigations described above and 6 months long cleaning of 80 new tubes. The replacement work took about 4 months as a result that it took several weeks more than expected to clean the column, check and stop many tiny vacuum leaks through gaskets and so on. The work itself was successfully done, but we were allowed to have only one week for conditioning. The conditioning was done in sectional bases. Stable voltages after a short (several hours for each) conditioning were 2.69MV(90%) for #1-#3 modules, 2.06MV(103%) for #4-#5, 3.68MV (92%) for #6-#9 and 6.25MV(91%) for #14-#20. The conditioning resulted in 15.8MV(80%) for the full column. The fact that we could start the beam time again soon after the tube replacement was as successful as we expected, although we are not satisfied with the voltage. We will have to make further effort to attain a voltage higher than 18 MV.

## SUMMARY

We planned an acceleration tube replacement program for the JAERI tandem accelerator, expecting an increase of the terminal voltages from 16 MV to 18-20MV by using compressed geometry tubes and applying high-pressure water jet rinsing to the tubes. For this program, we investigated the tube inner surfaces or ceramic surfaces and the effect of high-pressure water jet rinsing on the high-voltage voltage performance before carrying out the tube replacement.

Millions of loosely bound micro-particles were found in old and new tubes and cleaned well by high-pressure water jet sprays. The new ceramics contained smaller grains and more loosely bound micro-particles than old ones. This problem could be solved by cleaning.

The 3 MV high-voltage tests with six new tubes indicated that the high-voltage performance of the tubes were dramatically improved by the cleaning which included ultrasonic wave cleaning and high-pressure water jet spray rinsing. It should be noted that loosely bound micro-particles are source of discharge activities in the acceleration tubes.

The tube replacement was successfully done. We obtained the former voltage of about 16 MV by only one week conditioning. This program took a break for running the accelerator for user's experiments. We will need more conditioning and further investigations about the real accelerator system to get a terminal voltage of 18 - 20 MV.

## REFERENCES

- [1] M.J. Meigs *et al*, Proc. Symp. N.E. Accelerator Personnel(World Scientific, 1988) pp23-36.
- [2] C.Z.Antoine *et al*, Proc. 5th Workshop on RF Superconductivity, Hamburg(1991)pp456-462.
- [3] K. Saito *et al*, Proc. 6th Workshop on RF Superconductivity, Gif-sur-Yvette(1995)pp379-383.