

# A Review of Fixed Bed Gasification Systems for Biomass

Sangeeta Chopra<sup>1</sup> and Anil Kr Jain<sup>2</sup>

<sup>1</sup>Ph.D. Student and <sup>2</sup>Director

School of Energy Studies for Agriculture, PAU, Ludhiana, 141004, India

sangeeta.dhingra@yahoo.com, akjain\_123@yahoo.com

## ABSTRACT

The gasification of biomass into useful fuel enhances its potential as a renewable energy resource. The fixed bed gasification systems are classified as updraft, Imbert downdraft, throatless downdraft, crossdraft and two stage gasifiers. Updraft gasifiers are suitable for gasification of biomass containing high ash (up to 15 %) and high moisture content (up to 50 %) and generate producer gas having high tar content (50–100 g/Nm<sup>3</sup>). The high temperature (830 °C) air gasification of biomass in updraft gasifiers increase the lower calorific value of producer gas and reduce the tar content. The updraft gasifiers have been used for gasification of bark, wood blocks, chips and pellets, straw, maize cobs, refuse derived fuel (RDF), and waste pellets with air and O<sub>2</sub> as the gasifying media. The Imbert downdraft gasifiers are suitable to handle biomass fuel having ash and moisture content less than five per cent and 20% respectively. Modifications in the design of grate and hopper of Imbert downdraft gasifiers have been suggested to gasify non-woody biomass such as coir dust, cotton stalks, wheat straw, hazelnut shells, leather residues, sludge etc. Downdraft gasifiers yield producer gas with lower tar content (1-2 g/Nm<sup>3</sup>) than updraft gasifiers. Throatless downdraft gasifiers have been developed to overcome the problems of bridging and channelling in Imbert downdraft gasifiers. The throatless gasifiers have been successfully used for gasification of rice husk, wood chips, bagasse, sugarcane leaves, coconut shells etc. Improving the insulation of the gasifier, re-circulation of producer gas and varying the air distribution have been reported to enhance the performance of the throatless gasifiers and reduce the tar content to 50–250 mg/Nm<sup>3</sup>. In two stage gasifiers, pyrolysis and gasification of biomass takes place in separate chambers resulting in low tar (15–50 mg/Nm<sup>3</sup>) producer gas. Some aspects of the research and development in fixed bed gasification of biomass and their commercial applications are reviewed and cited in this paper.

**Keywords:** Biomass, fixed bed gasification, updraft gasifier, downdraft gasifier, throatless gasifier, two-stage gasifier.

## 1. INTRODUCTION

Global energy consumption is rising due to rapid industrialization and improvement in living standards. Nearly 80 % of the world's energy consumption is fossil fuel based which is causing environmental and health concerns due to increased emissions of CO<sub>2</sub>, NO<sub>x</sub> and SO<sub>2</sub>. After fossil fuels, biomass is the fourth largest source of energy. It supplies about 11-12 % of world's primary energy consumption. In developing countries, it is the predominant form of energy and accounts for about 38 % of their primary energy consumption and in rural areas 90 % of their total energy supplies. As 90 % of the world's population is expected to reside in developing countries by 2050, biomass energy is likely to remain a substantial energy feedstock (Kucuk and Demirbas, 1997 and Pathak, 2005, Sims 2003). Biomass has a high but

variable moisture content and is made up of carbon, hydrogen, oxygen, nitrogen, sulphur and inorganic elements. In comparison to fossil fuels, biomass contains much less carbon, more oxygen and a lower heating value in the range of 12-16 MJ/kg (Mukunda, *et al.*, 1994; Jain, 1997 and Pathak, 2005). The chemical energy of biomass can be converted to useful forms through biochemical, chemical and thermo-chemical conversion methods (Sokhansanj *et al.*, 2003, Zhou *et al.*, 2003). Only selected biomass can be converted into biogas, ethanol, bio-diesel etc. through biochemical and chemical methods, whereas most of the biomass material can undergo thermo- chemical conversion, thus making this method much more attractive than the others. Amongst the thermo-chemical conversion technologies, biomass gasification has attracted the highest interest as it offers higher efficiencies in relation to combustion. Gasification is a partial oxidation process at elevated temperatures (500-1400 °C) that results in producer gas consisting of CO, H<sub>2</sub>, CO<sub>2</sub>, CH<sub>4</sub>, traces of higher hydrocarbons such as ethane and ethene, water vapour, nitrogen (if air is the oxidizing agent) and various contaminants such as small char particles, ash, tar and oil. Gasification of biomass is primarily done in fixed and fluidized beds. The fixed bed gasifiers are suitable for small-scale applications (<10 MW<sub>th</sub>) and the fluidized bed configurations are cost effective in large-scale applications that generate over 15 MW<sub>e</sub> (Barker, 1996; Carlos, 2005; VTT, 2002 and Rajvanshi, 1986, Sims, 2003). This paper presents a review of the status of fixed bed gasification systems for biomass.

## 2. FIXED BED GASIFICATION SYSTEM

### 2.1 History

The first commercial updraft (fixed bed) gasifier was installed in 1839, when Bischof patented a simple process for gasifying coke. The first attempt to use producer gas to fire internal combustion engine was carried out in 1881 (Loewer, *et al.*, 1982). The downdraft gasifiers (wood gas generators) were used for power generation and automotive applications before and during the Second World War. After the end of the Second World War, availability of cheap fossil fuels led to decline of producer gas industry. The interest in biomass gasification was renewed after the energy crisis of 1970s'. The technology began to be perceived as a relatively cheap indigenous alternative for small scale industrial and utility power generation, especially in developing countries that suffered from high petroleum prices and had sufficient sustainable biomass resources (Stassen and Knoef, 1993)

### 2.2 Theory

The fixed bed gasification system consists of a reactor / gasifier with a gas cooling and cleaning system. The fixed bed gasifier has a bed of solid fuel particles through which the gasifying media and gas move either up or down. It is the simplest type of gasifier consisting of usually a cylindrical space for fuel and gasifying media with a fuel feeding unit, an ash removal unit and a gas exit. It is made up of firebricks, steel or concrete. In the fixed bed gasifier the fuel bed moves slowly down the reactor as the gasification occurs. The fixed bed gasifiers are of simple construction and generally operate with high carbon conversion, long solid residence time, low gas velocity and low ash carry over (Carlos, 2005; Reed and Das, 1988). In fixed bed gasifiers tar removal is a major problem, however recent progress in thermal and catalytic conversion of tar has given credible options. The fixed bed gasifiers are being considered to be of average strength for small-scale heat and power applications. The gas cleaning and cooling system normally consists of filtration through cyclones, wet scrubbers and dry filters (Carlos, 2005; Rajvanshi, 1986 and Demirbas, 2002, Riva 2006).

### 3. TYPES OF FIXED BED GASIFIER SYSTEMS

There are many types of fixed bed gasifiers with varying schemes for both reactor design and reaction media. The fixed bed gasifier can be classified according to the ways in which the gasifying agent enters the gasifier i.e. updraft, downdraft, crossdraft and two stage gasifier. The downdraft gasifiers are Imbert type (gasifier with throat) and open core type (throatless). The gasifying media may be air, steam, oxygen or a mixture of these and the producer gas may be used in thermal (heat gasifiers) or engine (power gasifiers) applications. The composition of producer gas and the level of contamination vary with the biomass, type of gasifier and operating conditions (Bridgwater,1999; Reed and Das,1988; Stassen and Knoef, 1995).

#### 3.1 Updraft Gasification Systems

##### 3.1.1 Principle

The updraft gasifier is the oldest and simplest form of fixed bed gasifier. It can handle biomass fuels with high ash (up to 15 %) and high moisture content (up to 50 %). It is more robust than other fixed bed gasifiers because it is less sensitive to variations in size and quality of biomass. In an updraft (counter current) gasifier, biomass fuel enters from the top of the reaction chamber and the gasifying media or agent (air, O<sub>2</sub> or mixture) enters from the bottom of the unit from below a grate. The fuel flows down slowly through the drying, pyrolysis, gasification and combustion zones. The ash is removed from the bottom. The updraft gasifier has high thermal efficiency as the sensible heat of the producer gas is recovered by direct heat exchange with the entering feedstock, which is dried, and pyrolysed before entering the gasification zone. The producer gas exits at low temperature (80-300 °C) and contains an abundance of oils and tar (10-20 %) since the products of the pyrolysis and drying zone are directly drawn into it without decomposition. The dust content in the producer gas is low due to low gas velocities and filtering effect of feed in drying and pyrolysis zones. (Carlos, 2005; Reed and Das, 1998; VTT, 2002; Stassen and Knoef, 1993).

##### 3.1.2 High Temperature Agent Gasification (HiTAG) in Updraft Gasifiers

The high temperature (>1000 °C) agent gasification in updraft gasifiers permits the gasification of a wide range of feedstock including low rank biomass fuels and waste such as sludge. The higher temperatures of the preheated feed gas lead to a lower yield of tar, higher production of producer gas rich in H<sub>2</sub> content. Carlos (2005) investigated the high temperature air/steam gasification process for gasification of bark, charcoal, woodchips and wood pellets in a conventional batch type countercurrent updraft gasifier. Preheated air, steam and air/steam mixture were used as gasifying media. Preheating of air up to 830 °C kept the temperature in the oxidation zone of gasifier above 1000 °C, which promoted the thermal cracking of tar in one step in the gasifier. The lower heating value (LHV) of producer gas, cold gas efficiency and specific gas production rate (SGPR) increased from 4.6 to 7.3 MJ/Nm<sup>3</sup>, 36.1 to 45.2 % and 744.9 to 916.6 kg m<sup>-2</sup> h<sup>-1</sup> respectively as the temperature of the preheated feed gas was increased from 350 to 830 °C. With preheated air of 830 °C the LHV (7.3 MJ/Nm<sup>3</sup>) of producer gas was well above that reported for downdraft gasifiers. When the feed gas used was mixture of steam and air, increase in the steam fraction with respect to the high temperature air favoured the water gas shift equilibrium and steam reforming of tars and hydrocarbons which led to increase in fraction of H<sub>2</sub> (10.4 to 29.9%) and decrease in CO (29.4 to 18.4%) in the producer gas. However use of steam lowered the temperature of gasification and the cold gas efficiency (43 to 37%).

Yang, *et al.*, (2006) investigated high temperature agent gasification (HiTAG) of wood pellets in a batch type updraft fixed bed gasifier (Fig.1). The gasifier was a vertical cylindrical reactor consisting of wind box and gasifier bed. The feedstock bed was supported by a bed of ceramic balls placed on perforated disk inside the reactor. The gasification process became faster with increase in temperature of feed gas (650 to 830 °C). The higher feed gas temperature led to increase in concentration of CO (20.1 to 26.8 %) and H<sub>2</sub> (6.6 to 12.7 %) in producer gas. The critical feed gas temperature (at which the yield of gaseous products was maximum) was between ignition temperature of biomass and the melting temperature of the ash in the biomass.

### 3.1.3 Gasification of Non-Woody Biomass in Updraft Gasifiers

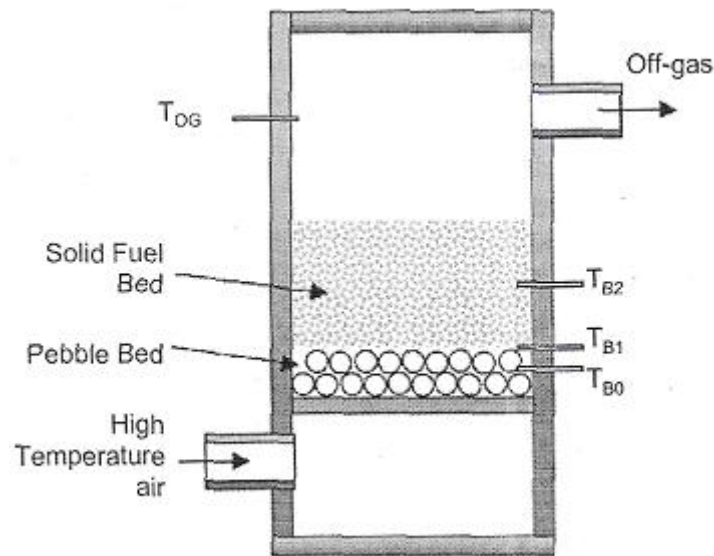

Fig.1. Updraft gasifier for high temperature air gasification

The updraft gasifier was generally used for gasification of conventional biomass fuel like wood, wood chips, bark etc. However Rao, *et al.*, (2004) studied the gasification of non-conventional fuels like low-density refuse derived fuel (RDF) pellets in an updraft gasifier with an inclined grate. The grate inclination helped in crushing of large clinkers. An air-partitioner in the gasifier ensured uniform distribution of air in the combustion zone. The high heating value (HHV) and energy content of producer gas was 5.58 MJ/Nm<sup>3</sup> and 12.2 MJ/kg respectively. The tar content from RDF pellets was 45 % less than that in gas generated from wood chips. The specific gasification rate of RDF pellets was within the range reported for updraft gasifiers with fixed grate i.e. SGR 100-200 kg m<sup>-2</sup>h<sup>-1</sup>. The cold gas efficiency obtained with RDF was 73 %, which was over 8 % higher than that obtained with wood chips.

Na, *et al.*, (2003) gasified combustible waste pellets in an updraft fixed bed gasifier lined with alumina refractory (Fig. 2) using O<sub>2</sub> as the gasifying medium. The composition of H<sub>2</sub> and CO in the producer gas was in the range 30-40 % and 15-30 % respectively depending on oxygen/waste ratio. As the bed height was increased the H<sub>2</sub> and CO content in producer gas increased whereas CO<sub>2</sub> content reduced. Gasification was difficult above a bed height of 700 mm because of pressure drop of O<sub>2</sub>. The cold gas efficiency was around 61 % at O<sub>2</sub>/waste ratio of 0.4-0.5 and the heating value of producer gas was 11.72-13.40 MJ/Nm<sup>3</sup>, which was more than heating value of producer gas generated by air gasification. The gas was cleaned of the particulate matter by a cyclone. O<sub>2</sub> gasification was reported to produce a medium heating

value (MHV) gas (10-18 MJ/Nm<sup>3</sup>), which is suitable for limited pipeline distribution and as synthesis gas for conversion to methane and methanol.

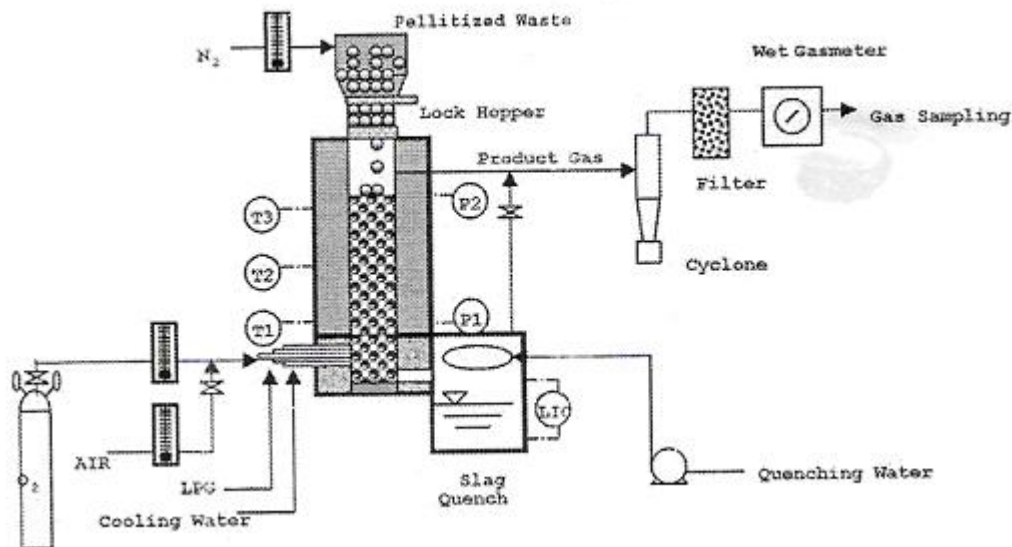

Fig. 2. Updraft gasifier using O<sub>2</sub> as gasifying medium

### 3.1.4 Application of Updraft Gasifier Systems

The producer gas from updraft gasifier has high amount of tar and is therefore mostly used in thermal applications i.e. close coupled steam boilers and crop dryers. Payne, *et al.*, (1983) investigated the performance of an updraft gasifier (Fig.3) used in conjunction with a combustor for grain drying. Maize cobs of varying moisture content (9-46 %) were gasified in the gasifier with primary air as the gasifying medium. The producer gas was then completely combusted with secondary air and the exhaust gas mixed with the ambient air and used directly for drying the grain. The total particulate emission was proportional to the second power of the gasification rate (amount of corncobs gasified per unit grate area per unit time), which in turn was dependent on the corncob moisture content and primary airflow rate.

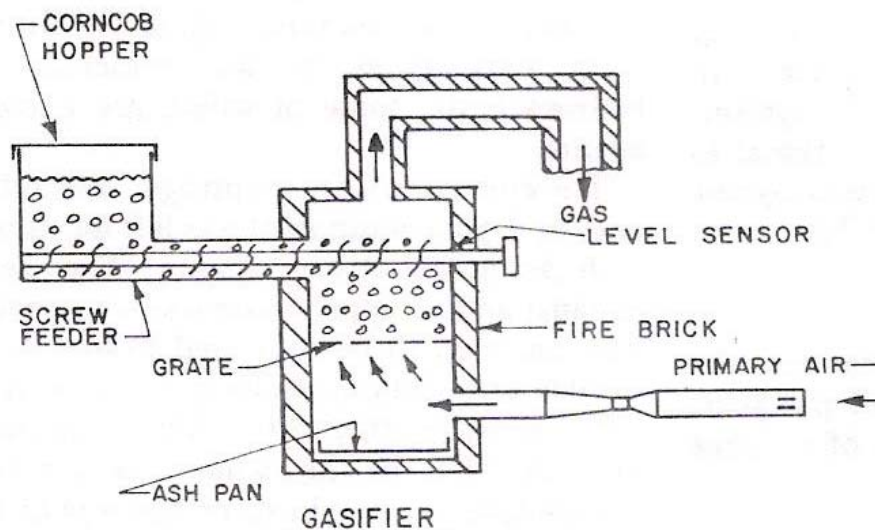

Fig. 3 Updraft gasifier for corn drying

VTT (2002) reported commercial use of an updraft fixed bed gasifier of 8 MW capacity (BIONEER) for thermal applications. The gasifier consisted of a refractory lined vessel with a rotating cone shaped grate. The temperature of the combustion zone was controlled by humidification of gasification air. The gasifier was used to gasify a variety of feedstock (wood chips, forest wastes, peat, straw etc) and the gas was used for burning in a boiler to generate hot water. For successful operation the biomass fuel had moisture content less than 50 %, ash less than 10 % of dry matter with minimum softening point of ash above 1190 °C. Above 50 % moisture content the producer gas contained lot of tar aerosols. The producer gas generated from gasification of wood chips of 41 % moisture content consisted of 30 % CO, 11 % H<sub>2</sub>, 3 % CH<sub>4</sub>, 7 % CO<sub>2</sub>, and 49 % N<sub>2</sub> with HHV of 6.2 MJ/Nm<sup>3</sup>. The tar content of dry producer gas was in the range 50–100 g/Nm<sup>3</sup>. The gasifier proved to be economically feasible for small heating systems.

Leung, *et al.*, (2004) reviewed the gasification technologies being applied in China and surmised that the updraft gasifiers of capacity 2–30 kW were used for gasification of tree barks and timber blocks generating producer gas of lower heating value 4.1–5.3 MJ/Nm<sup>3</sup> at efficiency of 70–75 %. The producer gas was being used as boiler fuel commercially.

The high amount of tar and pyrolysis products in the producer gas of updraft gasifier makes it highly unsuitable in engines and gas turbines. Barker, *et al.*, (1996) reported that the updraft gasification between 2 – 20 MW was suitable for supplying fuel gas to reciprocating engines at efficiency of 30–35 % only, if the gas phase tars were cracked into smaller components, which do not condense at lower temperatures. This can be done by thermal cracking i.e. by raising temperature of gasifier over 1200 °C as in HiTAG (Carlos, 2005 and Yang *et al.*, 2006)

### 3.2 Imbert Downdraft Gasification System

#### 3.2.1 Principle

The Imbert downdraft gasifier or throated downdraft gasifier features a cocurrent flow of gases and solids through a descending packed bed, which is supported across a constriction or throat. The biomass fuel enters through the hopper and flows down, gets dried and pyrolysed

before being partially combusted by the gasifying media (air) entering at the nozzles. The throat allows maximum mixing of gases in high temperature region, which aids tar cracking. Below the constriction or 'throat' the combustion gases along with tar pass through the hot char and are reduced to primarily CO and H<sub>2</sub>. The gasifier can handle uniformly sized biomass fuels having moisture content and ash content less than 20 % and 5 % respectively. The throated (Imbert) downdraft gasifier is generally used for gasification of woody biomass of uniform sizes and shapes (blocks) as they flow smoothly through the constricted hearth. The producer gas from downdraft gasifier has lesser tar-oils (<1 %), higher temperature (around 700 °C) and more particulate matter than that from an updraft gasifier. The gasifier has lower overall efficiency since a high amount of heat content is carried over by the hot gas (Clarke, 1981; Reed and Das, 1988). The physical limitations of biomass particle size limit the capacity of the throated downdraft gasifiers to 500 kW.

### 3.2.2 Modifications in Throated Downdraft Gasifier System

The throat of the downdraft gasifier presents a hazard to low-density biomass fuels. The biomass in form of twigs, sticks or bars does not flow down smoothly causing bridging and channelling leading to increased tar production. The throated downdraft gasifier operation is very sensitive to feedstock size and quality. Modifications have been made in the gasifier to successfully gasify the low and medium density fuels like stalks, shells etc.

Liinanki, *et al*, (1985) introduced a rotating grate and a double conical hopper in a downdraft gasifier for gasification of coir dust, cotton stalk and wheat straw. The fuel had lower density and higher ash content compared to that of wood and was densified into briquettes. The double conical hopper in the gasifier (Fig.4) created space for the fuel briquettes to expand when they were heated up to avoid the bridging problem in the pyrolysis zone. A rotating grate fed out the slag particles before their agglomeration in the gasifier. The distance between the choke plate and the grate was also increased to increase the volume of the reduction zone to get better distribution of slag in the char bed. The gasification system consisted of a gasifier with a cyclone for coarse dust removal and a glass fibre-fabric for removal of fine material. The cold gas efficiency was 72-77 %. The tar content was below 1 g/Nm<sup>3</sup>. Wheat straw pellets were also tested but due to small particle size, streams of cold gas passed between the throat and air nozzles resulting in incomplete tar cracking and in producer gas with high tar content.

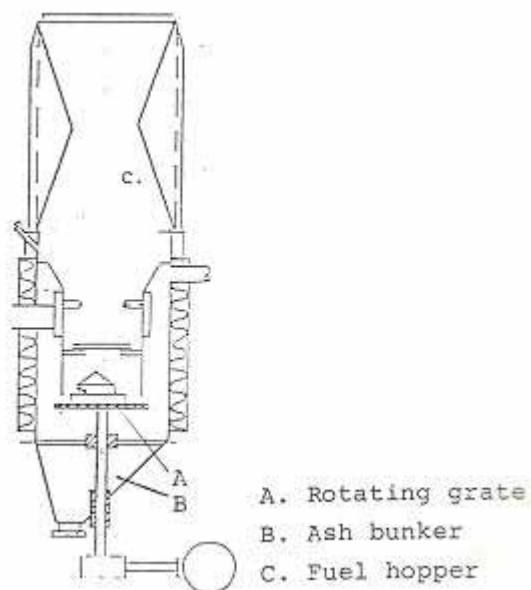

Fig. 4. Downdraft gasifier modified for non-woody biomass

Jayah *et al.*, (2003) investigated the gasification of chips of rubber wood of varying moisture content (12.5-18.5 %) and chip size (3.3–5.5 cm) in an 80 kW downdraft throated gasifier, which was double walled with an air gap in between. During the operation the gasifier was shaken to avoid bridging of fuel in throat. Small chips underwent faster char conversion increasing the conversion efficiency and therefore required smaller gasification zone length. Higher throat angle decreased temperature, reaction rate and conversion efficiency whereas smaller angles required a longer gasification zone length to reach optimum efficiency. For wood chip of moisture content 15 %, the optimum chip size was 5 cm, gasification zone length 22 – 33 cm, throat angle  $61^{\circ}$  and conversion efficiency 56 %. The tar, water vapour and ash content were 7-9 % of the producer gas output.

Sasidharan, *et al.*, (1995) reported that downdraft gasifiers lined with ceramic material had greater life and lesser cost than downdraft gasifiers made of austenitic steel for biomass gasifier system below 500 kW. The gasifier made of steel failed at the throat and air nozzle region due to high temperature oxidation and corrosion mostly within 1500 hours of operation whereas the gasifier lined with ceramic material could withstand thermal shock. The composition of ceramic material was alumina (50-70 %), kaolin (16-20 %), feldspar (10-15 %) and talc (3-7 %).

Warren, *et al.*, (1995) reduced the grate spacing and increased the grate height so that it does not block with char in downdraft throated gasifier used for gasification of wood chips of coppice willow and poplar. The fine particles of the wood chips blocked the flow of air reducing the temperature in some areas of the throat. A fuel agitator was used to stir up the wood chip to allow free fuel flow but it was ineffective. The bridging of the fine fuel particles was not solved successfully so the fuel had to be removed of these particles prior to gasification.

### 3.2.3 Gasification of Non-Woody Biomass in Throated Downdraft Gasifier

Dogru, *et al.*, (2004) and Midilli, *et al.*, (2004) also used the throated downdraft gasifier to gasify briquetted-buffing dust leather (BDLW) residues of moisture content 11.23% (d.b.). As the feed rate of BDLW increased from 2.09–5.04 kg/h, 0.08–0.21 kg/h of ash, 0.04–0.06 kg/h of tar and 0.60–1.39 kg/h of condensate were obtained. The flow rates of wet gas



increased almost linearly from 3.78 Nm<sup>3</sup>/h to 9.72 Nm<sup>3</sup>/h, with the increase of the fuel feed rate. The combustible gases varied between 29 and 33 % of the total wet gas produced. The most productive region for the gasification of leather residues was between 486.39 and 584.36 Nm<sup>3</sup> m<sup>-2</sup> h<sup>-1</sup> of the specific gasification rate (SGR). The optimum efficiency of cold gas was 46.50 % around 486.39 Nm<sup>3</sup> m<sup>-2</sup> h<sup>-1</sup> of the SGR. The large briquette sizes of the leather residues occasionally formed bridging in the throat zone of the gasifier.

Midilli, *et al.*, (2001) gasified sewage sludge in a throated downdraft gasifier of 10 kW capacity and the producer gas generated had 19-23 % combustible gases and LCV of 2.55-3.2 MJ/Nm<sup>3</sup>. Dogru, *et al.*, (2002) investigated the gasification of hazelnut shells of moisture content 12 % (d.b.) in a 5 kW throated downdraft gasifier. The optimum operation of the gasifier was between 1.44 and 1.47 Nm<sup>3</sup>/kg of air fuel ratios and 4.06 and 4.48 kg/h of wet feed rate. The high quality of producer gas of HHV (4.75 –5.15 MJ/m<sup>3</sup>) was due to high throat temperature (1015-1206 °C) and low char (0.201-0.228 kg/h) and low tar (0.023-0.025 kg/h) content. There was no sign of bridging or ash fusion at optimum throat temperature of 1000-1050 °C since the ash content in hazel nut shells was quite low i.e. 0.77 %. At higher flow rates of air (>1.5 Nm<sup>3</sup>/kg), the HHV of producer gas showed a significant decrease while tar output increased as more air resulted in more combustion. The producer gas was cleaned and cooled by passing through a packed bed scrubber and a dry filter with wood or charcoal.

### 3.2.4 Applications of Throated Downdraft Gasifier

The producer gas from downdraft gasifier is used for thermal application like grain drying or as fuel in boiler. Kutz, *et al.*, (1983) used a downdraft-throated gasifier (830 MJ/h) in conjunction with a combustor for grain drying. The throat of the gasifier was made up of V shaped channels framed by triangular ducts, which were subdivided to separate primary air from secondary air. The gasifier was insulated with firebricks lined by mild steel shell. The air was preheated as it traveled through the ducts. The maize cobs having 8.1, 23.2 and 32 % moisture content were gasified with air. As the primary airflow rate increased the gasification rate increased linearly whereas as moisture content of biomass increased the gasification rate decreased. The turn down ratio also decreased with the increase in moisture content of biomass and was 3:1 at 8.1% moisture content. The particulate emission to energy input ratio was 134 mg/MJ, which was above the EPA standard for that from high capacity coal fired boilers.

The downdraft gasifier with throat is known to generate best quality producer gas with minimum tar for engines (Jain 2006). Sheng, (1989) reported that the downdraft gasifiers with throat were commercially available in China (Fig. 5). These could operate on multi-fuels (wood, corncobs, hard nut shells, sawdust and hard coal) and the producer gas had 20-28 % CO and over 12 % H<sub>2</sub> content and was suitable to drive diesel engines.

Warren, *et al.*, (1995) used the throated downdraft gasifier for gasification of wood chips of coppice willow and poplar. The producer gas was passed through a twin cyclone, a pipe and fin cooler and a sawdust and foam filter to remove particulate matter and tar. It was mixed with air in a venturi before using in an engine to generate 30 kW of electricity (Fig. 6).

A 10 kW downdraft throated gasifier was tested for various biomass fuels after their pre-treatment (size reduction and/or briquetting). The producer gas was used as a supplementary fuel in diesel engine pump set. The producer gas from the gasification of acacia auriculiformis, wood chips, fuel wood and sorghum stems replaced diesel in compression ignition (CI) engines by 70-76 %, 62.25 %, 22.5 % and 58.60 % respectively. In another trial

of 3.75 kW downdraft throated gasifier, tamarindus and maize cobs were gasified and producer gas replaced 62.27 % and 48-52 % of diesel respectively (Jain, 1996).

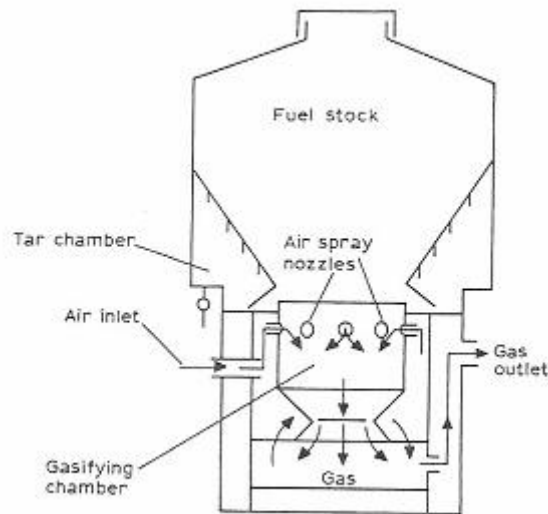

Fig. 5 Multifuel downdraft gasifier

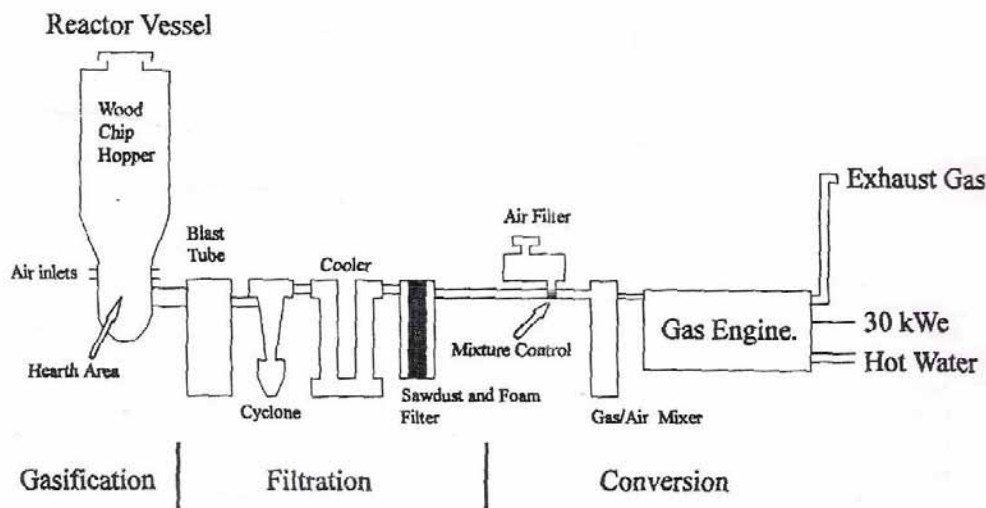

Fig. 6. Downdraft gasification system for engine application

Ghosh, *et al.*, (2004) reported 5 x 100 kW downdraft gasifiers being used for electrification of 5 villages in Gosaba islands in West Bengal, India. Each 100 kW downdraft gasifier was equipped with a water sprayed gas cooling system, two-stage gas cleaning system, blower, an engine (165 hp) coupled to a 125 kVA alternator and pump sets for circulating water in the gas cooling tower and for removal of ash from the reactor. The average consumption of fuel wood and diesel per kWh of electricity generated was 0.822 kg and 0.135 l. The diesel replacement by producer gas was 59 %. The overall efficiency of the Gosaba plant was 19 %.

Leung, *et al.*, (2004) reported the use of downdraft gasifiers with efficiency of 75 % in China for gasification of straw for domestic cooking. The output of the gasifiers ranged from 60-200 kW and the heating value of producer gas was 3.8-4.6 MJ/m<sup>3</sup>.

### 3.3 Throatless Downdraft Gasification Systems

#### 3.3.1 Principle

The throatless (stratified or open top) downdraft gasifier was developed to overcome the problem of bridging and channeling in throated (Imbert) downdraft gasifiers. The gasifier consists of a cylindrical vessel with a hearth at the bottom. During operation the air and biomass move downwards through the four zones in the reactor. The open top ensures uniform access of air and permits fuel to be fed easily and uniformly, which keeps the local temperatures in control. The hot producer gas generated is drawn below the grate and up through the annulus of the reactor, where a part of the heat of the gas is transferred to the cold fuel entering the reactor, improving the thermal efficiency of the system (Reed and Das, 1988 and Mukunda, *et al.*, 1994). The pyrolysis components are cracked in the oxidation zone, as gas traverses a long uniformly arranged bed of hot char without any low temperature zones, therefore the tar generated is low 0.05 kg tar/kg gas. The open top throatless gasifier is suitable for small sized biomass having high ash content up to 20 % (Stassen and Knoef, 1993, Jain 2000b and Sims 2003, Tiwari *et. al.* 2006 ). The gasifier is easy to construct and has good scale up properties.

### 3.3.2 Modifications in Design of Throatless Gasifiers

In order to improve the performance of throatless (stratified or open top) gasifier and use it for power and heat applications, changes were made in the design by allowing a varying air distribution in the gasifier, improving insulation of gasifier and re-circulating the gas within the gasifier.

Mukunda, *et al.*, (1994) developed an open top gasifier consisting of a vertical tubular reactor with an open top and a water seal at the bottom. The lower two-thirds of the reactor was lined with a ceramic material to prevent high temperature corrosion. The upper part of the reactor was made of stainless steel with an annular jacket around it. The producer gas was drawn from below the grate and taken through an insulated pipe (re-circulating duct) to the upper annulus of the reactor where part of the sensible heat of the gas was transferred to the cold wood chips inside the reactor improving the thermal efficiency of the system. The entire reactor surface along with the re-circulating duct was insulated with aluminosilicate blankets.

Dasappa *et al.*, (2003) developed an open top downdraft reburn reactor, a cylindrical vessel made of mild steel, with an inner lining of ceramic. Air nozzles were provided around the combustion zone. Uniform air distribution across the section was established by locating these nozzles at two different heights. The dual air entry – from top and the nozzles – favoured a high residence time for gases at elevated temperatures, thus eliminating the tar. The top of reactor helped in loading of fuel. The fuel bed was supported on an ash extraction screw. The screw was operated based on the ash content of biomass and / or the pressure drop across the reactor. Two discharge outlets were provided for ash extraction.

Wander *et al.*, (2004) developed an open top stratified gasifier with internal gas recirculation, which could burn a part of the gas produced to raise the gasification temperature. The gasifier (Fig. 7) consisted of a cylinder with a cast iron grate fixed to a rotating shaft. Rods were fixed on the shaft to mix sawdust in the reduction zone and to extract the ash. In the center of the gasifier a device like a venturi aspirated part of the gases produced in it to be burnt in a chamber. The gasifier was used for gasification of 12 kg/h of sawdust of moisture content (9-11 %). With no recirculation of gases, the air / sawdust ratio had to be kept above 1.5 to get cold gas efficiency of 60 %, whereas with re-circulation of gases, the ratio was lower i.e. 1.1 – 1.4. Gas re-circulation raised the gasification reaction temperature, helped in burning a part of the tar and improved efficiency of gasifier. Strong mixing of sawdust was required to avoid bridging and channeling. The gasifier was used with a cyclone to remove particulate matter from producer gas.

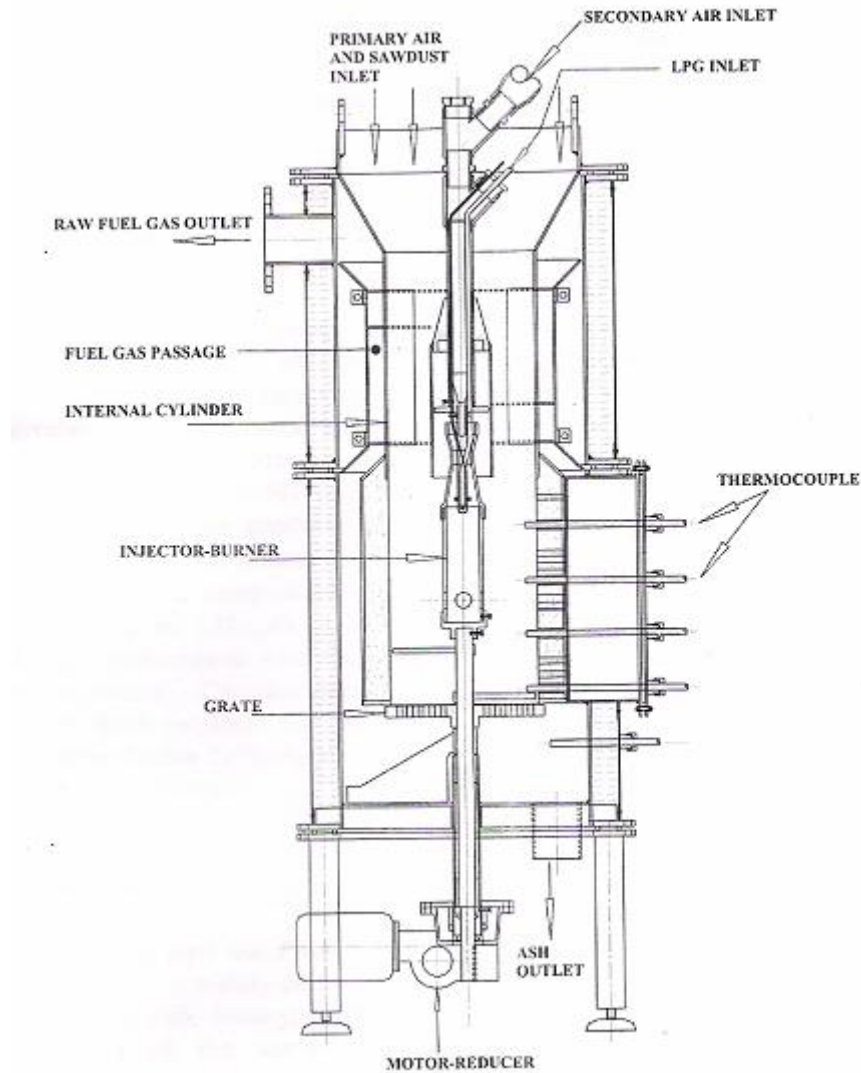

Fig. 7 Stratified gasifier with gas re-circulation

In another trial on the open core gasifier with gas re-circulation conducted by Altafini *et al.*, (2003) the feed rate of sawdust, temperature and pressure in the gasifier was 11.34 kg/h, 800 °C and 0.93 bar respectively. The moisture content of sawdust was varied from 0 – 30 %. It was observed that as the moisture content of the sawdust increased the air/sawdust ratio had to be increased to keep the temperature constant. The LHV of the producer gas reduced with the increasing moisture content of sawdust. Maximum cold gas efficiency (68 %) was achieved with sawdust having moisture content of 20 %.

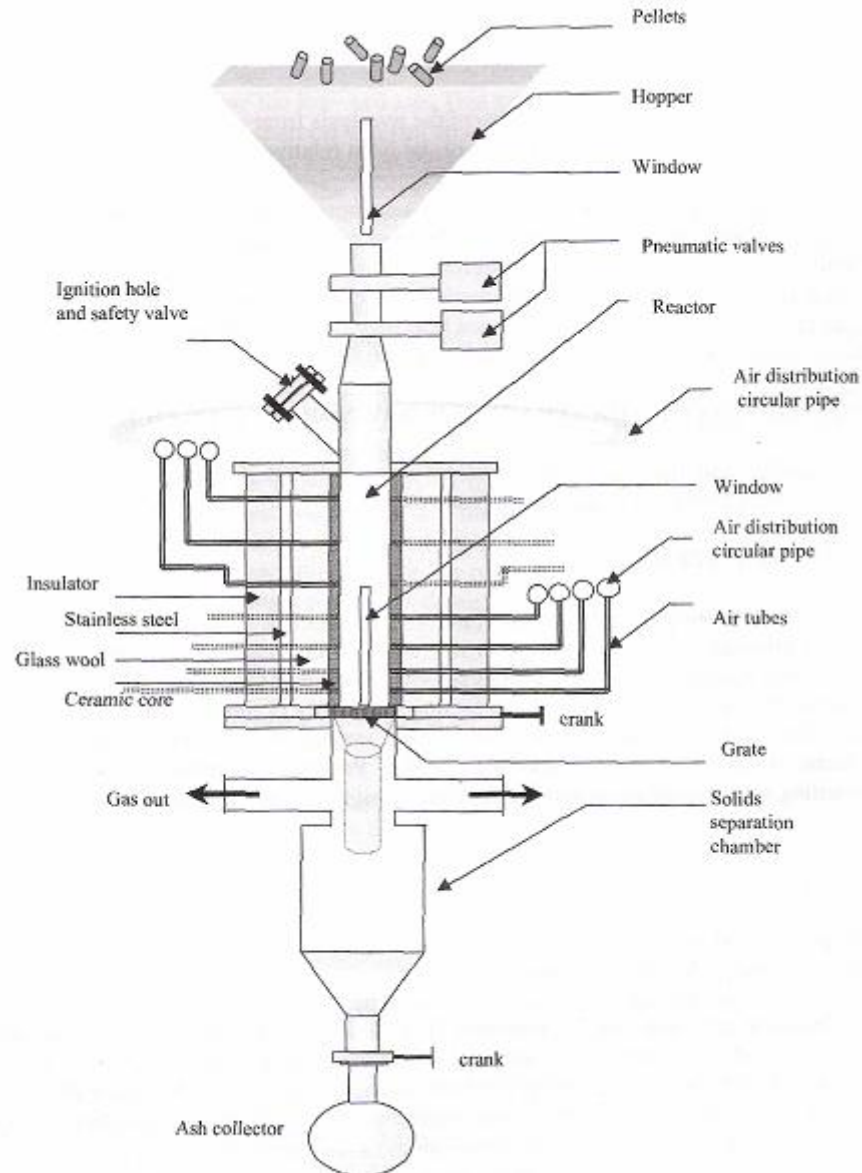

Fig. 8 Stratified downdraft gasifier

Barrio, *et al.*, (2001) used a small-scale (30 kW) stratified downdraft gasifier (Fig. 8) to gasify wood pellets at a feed rate 5 kg/h. The design of the gasifier allowed for variation in the point of air injection along the length of gasifier. The grate was a perforated plate with a crank, which could be shaken manually. The equivalence ratio was lower (0.3) when air was taken in from the top (80 %) and sides (20 %) of the gasifier. It was 0.4-0.45 when 100 % air was taken in from the top (traditional open core). The gasifier produced 12 Nm<sup>3</sup>/h of producer gas with a calorific value of 5 MJ/Nm<sup>3</sup> and CO and H<sub>2</sub> content of 20% each.

### 3.3.3 Optimization of Operating Conditions of Throatless Gasifiers

The specific gasification rate (SGR) i.e. rate of fuel consumption per unit area of reactor area has been optimized for throatless gasifiers. Knowing the optimal value of SGR, the size of the reactor can be computed from the energy demand of the gasification system. Tiangco, *et*

*al.*, (1996) gasified rice hulls in an open core or static bed gasifier of varying reactor diameters from 16-30 cm. The specific gasification rate was varied in the range of 100-400  $\text{kgm}^{-2}\text{h}^{-1}$ . As the specific gasification rate (SGR) increased the producer gas flow rate and reaction airflow ratio increased. The cold gas efficiency increased up to an optimum value of SGR and then decreased. The highest cold gas efficiency was between 50-60 % at SGR of 200  $\text{kgm}^{-2}\text{h}^{-1}$ . It was observed that the cold gas efficiency and optimum value of SGR were independent of the size of the reactor thus indicating that SGR could be used satisfactorily to upscale the reactor size.

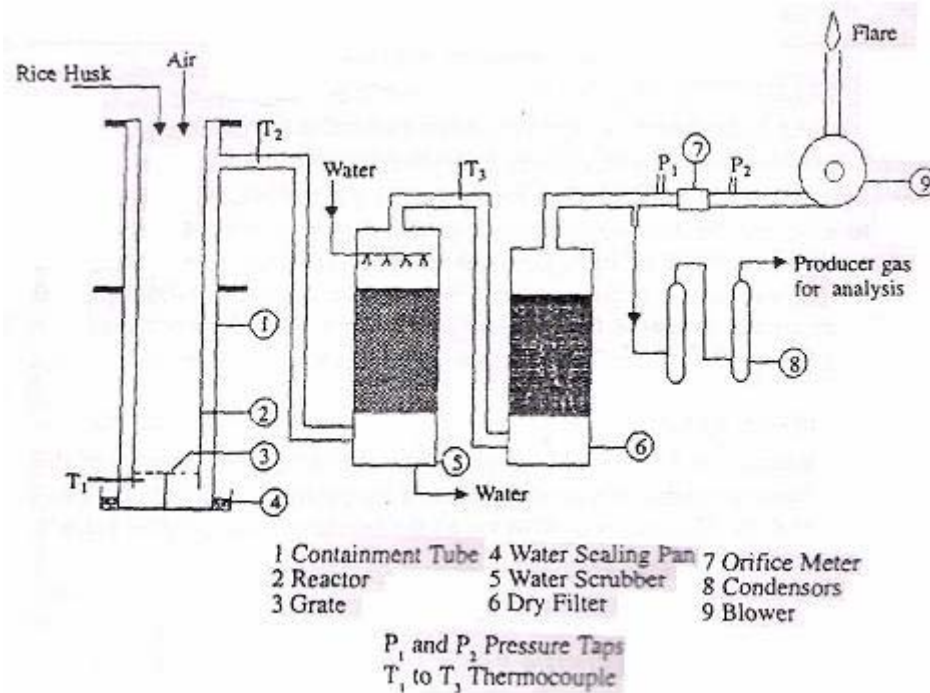

Fig. 9 Throatless gasifier for gasification of rice husk

Jain, *et al.*, (2000b) developed the design parameters for rice husk throatless gasifier for engine applications. The gasifier was made of two concentric cylinders of mild steel the inner one being reactor and the outer the containment tube. The grate was made of stainless steel wire mesh. The gas was passed through packed bed water scrubber and dry filter (Fig. 9). SGR was varied in the range 110-240  $\text{kgm}^{-2}\text{h}^{-1}$ . As the SGR increased the equivalence ratio increased from 0.33 to 0.44. The cold gas efficiency increased from 53 to 69 % up to SGR of 190  $\text{kgm}^{-2}\text{h}^{-1}$ . Further increase in SGR reduced the efficiency. The optimum value of SGR, at which the gasification efficiency was maximum, was 190  $\text{kgm}^{-2}\text{h}^{-1}$ . Jain and Goss (2000a) conducted gasification of rice husk in open core throatless batch fed gasifiers of four different diameters to develop the up scaling parameters for gas production. For all the reactors the gasification efficiency was the maximum (65 %) between SGR as 190-195  $\text{kgm}^{-2}\text{h}^{-1}$ . The specific gas production rate (SGPR) was 410-429  $\text{m}^3\text{h}^{-1}\text{m}^{-2}$  and equivalence ratio was 0.4. The LHV of producer gas was 4  $\text{MJNm}^{-3}$ . The optimum SGR and specific heat rate for 100 kg/h rice husk gasifier system was 200  $\text{kgm}^{-2}\text{h}^{-1}$  and 2.7  $\text{GJ m}^{-2}\text{h}^{-1}$  respectively (Jain, 2006).

Singh, *et al.*, (2006) carried out the gasification of cashew nut shells in an open core downdraft gasifier of capacity 150,000 kcal/h at varying gas flow rates. The maximum gasification efficiency was 70 % at SGR of 167  $\text{kgm}^{-2}\text{h}^{-1}$ . The producer gas flow rate was 130

$\text{m}^3/\text{h}$  and its LHV was  $1081 \text{ kcal}/\text{m}^3$ . The producer gas was used for thermal applications like boilers through direct combustion or for heating air using heat exchangers.

### 3.3.4 Applications of Throatless (stratified or open top) Gasifiers

Jorapur and Rajvanshi (1997) developed a commercial scale (1080 MJ/h) low-density biomass gasification system for thermal applications at Nimbkar Agricultural Research Institute (NARI), India. The reactor was lined by high temperature resistant firebricks on the inner side. The gas conditioning system consisted of high temperature char/ash coarse settler and a high efficiency cyclone separator. The gasifier was operated on sugarcane leaves, bagasse and their mixture and the HHV of the gas was between  $3.56\text{--}4.82 \text{ MJ}/\text{Nm}^3$ . The system also produced char, (with gross calorific value of  $18.9 \text{ MJ}/\text{kg}^1$ ) which was about 24 % by weight of the original fuel. The output was in the range of  $288\text{--}1080 \text{ MJh}^{-1}$ . The temperature of the gas was greater than  $300 \text{ }^\circ\text{C}$  and so there was no condensation of tars and particulate matter. The performance of the gasifier was excellent up to fuel moisture content of 15 %.

Dasappa, *et al.*, (2003) used throatless reactors of capacity  $500 \text{ kg}/\text{h}^1$  and  $300 \text{ kg}/\text{h}^1$  were used for low ( $100 \text{ }^\circ\text{C}$ ) and high ( $600 \text{ }^\circ\text{C}$ ) temperature applications respectively. The low temperature application was drying of marigold flowers for which the coconut shells were gasified and gas from the gasifier system replaced diesel fuel in the range of  $125\text{--}150 \text{ l}/\text{h}^1$ . The high temperature application was for a heat treatment furnace in which biomass gasifier replaced 2000 l of diesel per day. The gas quality after cleaning and cooling through a cyclone and water scrubber was comparable to that which could be used in engines.

Mukunda, *et al.*, (1994) reported that producer gas from throatless gasifier could be used for engine (power) applications as it contained low amount of tar. The gasifier was used for gasification of wood chips. The ratio of the cold gas flow rate to wood chips consumption rate was about 2.6. The composition of gas was 18 %  $\text{H}_2$ , 19 %  $\text{CO}$ , 1.25 %  $\text{CH}_4$ , 12 %  $\text{CO}_2$  and  $\text{N}_2$ . The calorific value ranged from  $4 \text{ MJ}/\text{kg}$  to  $4.4 \text{ MJ}/\text{kg}$ . The amount of tar and particulate matter in producer gas were  $100 \text{ mg}/\text{m}^3$  and  $700 \text{ mg}/\text{m}^3$ . They were reduced to  $20 \text{ mg}/\text{m}^3$  and  $50 \text{ mg}/\text{m}^3$  respectively after cleaning through a sand filled coarse filter and a fine filter. The total efficiency of the system measured in relation to the final electric energy was 27 % in a 100 kW compression ignition engine with 85 % diesel replacement.

Sardar Patel Renewable Energy Research Institute (SPRERI), India developed a 3.5 kW throatless gasifier for gasification of paddy husk and the producer gas was used in a diesel engine pump set. The average diesel replacement and specific husk consumption was 61.1 % and  $9.2 \text{ kg}/\text{h}$  respectively. Punjab Agricultural University, India developed a 10 kW throatless downdraft paddy husk gasifier coupled to a diesel engine. The gasifier efficiency, tar content and diesel replacement were 67 %,  $75 \text{ mg}/\text{Nm}^3$  and 75 % respectively at 8 kW load (Jain, 1996).

Leung, *et al.*, (2004) reviewed the open core gasifiers (60–200 kW) being developed in China for electricity generation. These operated on rice husk and produce producer gas of lower heating value  $3.8\text{--}4.6 \text{ MJ}/\text{m}^3$  with efficiency of 50 %.

Dasappa, *et al.*, (2004) tested the open top ceramic lined reactor for gasification of biomass with varying moisture contents up to 37 % and studied the variation of tar and particulate in the raw gas. The tar content in this reactor design was lower due the high quality insulating material used for reactor and air distribution between the nozzle and the reactor top. The cracking of the tars improves the overall gasification efficiency. With increase in moisture content, the tar level in the gas increased and particulate matter reduced. The tar content in

the raw gas was in the range of 50–250 mg/Nm<sup>3</sup> for fuel having moisture content less than 15 %, beyond which it increased to about 700 mg/Nm<sup>3</sup>. At a capacity of 75 kg/h the cold gas efficiency was around 75 %, whereas the large capacity gasifier system of 650 kg/h resulted in cold conversion efficiencies in the range of 85 %. The fraction of tar and particulate matter in the hot gas from open top reactor were observed to be lower than in the Imbert design. The gasification system consisted of the gasifier, high efficiency cyclone, and ejector scrubber to cool and clean gas before using it in the engine. Diesel savings of up to 70 % and an overall efficiency of 20 % were achieved.

### 3.4 Two Stage Gasifier System

#### 3.4.1 Principle

In contrast to the updraft, throated and throatless downdraft gasifiers where pyrolysis and gasification zones occur in the same chamber, these zones were separated in the two stage gasifier which improved control of the process temperatures resulting in markedly lower tar production and a high energy efficiency (McKendry, 2002; Hindsgaul, *et al.*, 2000). Experts have estimated that for internal combustion engine applications, the tar level in producer gas should be less than 30-50 mg/Nm<sup>3</sup> (Milne and Evans, 1998) to avoid problems associated with tar condensation on critical engine parts. Stassen and Knoef (1993) while conceding that some engine fouling is inevitable when fuelled by producer gas suggested that up to 100 mg/Nm<sup>3</sup> is acceptable and less than 50 mg/Nm<sup>3</sup> is preferable. The tar content was reported to range from 2 g/Nm<sup>3</sup> in a conventional downdraft gasification of wood to 58 g/Nm<sup>3</sup> in conventional updraft gasifiers (Bui *et al.*, 1994).

Bui *et al.*, (1994) investigated that the two-stage gasifier was very effective in producing clean gas. The concept of this design was to separate the pyrolysis zone (first stage) from the reduction zone (second stage). The gasifier has two levels of air intakes, primary air supply at the top section and secondary air at the middle section of the gasifier. The high temperature achieved in the second stage due to the addition of a secondary air helps in reducing the tar level to a considerably lower value. The two-stage gasifier resulted in gas having tar content about 50 mg/m<sup>3</sup>, about 40 times less than a single-stage reactor under similar operating conditions. However most of the tars were formed during the warm-up period. This could be avoided by filling the gasifier with a bed of char, which almost totally eliminated tar formation during start-up in the reactor.

#### 3.4.2 Modifications in Design of Two Stage Gasifier System

The modification in the design of two stage gasifier was done by Bhattacharya, *et al.*, (1999) in such a way that char was produced inside the gasifier itself, thus avoiding input of external char. For this purpose, an extra air inlet above the original primary air supply was added. The tar content in producer gas reduced with increase in the flow rate of primary and secondary air. The lowest value of tar was 45 mg/Nm<sup>3</sup> at primary and secondary air flow rates of 120 lmin<sup>-1</sup>. The gas composition also improved at higher airflow rate because of high temperatures in the gasifier.

A two-stage gasifier designed at the Technical University of Denmark was a combination of pyrolysis of the biomass feed with subsequent partial oxidation of the volatile products in presence of a char bed. Brandt, *et al.*, (2000) used the reactor (Fig.10) of 100 kW capacity for gasification of wood chips. The char and the volatile pyrolysis products from the pyrolysis unit entered the top of the gasification unit where the gases were mixed with the preheated steam and air starting partial combustion. The gases were allowed to pass through the bed of char resulting in significant tar reduction (15 mg/m<sup>3</sup>). Lower amounts of tar were attributed to



partial combustion of the pyrolytic gases as well as the catalytic effect of the char bed. The gas cleaning system consisted of a hot cyclone, gas cooler, venturi scrubber and a gas filter.

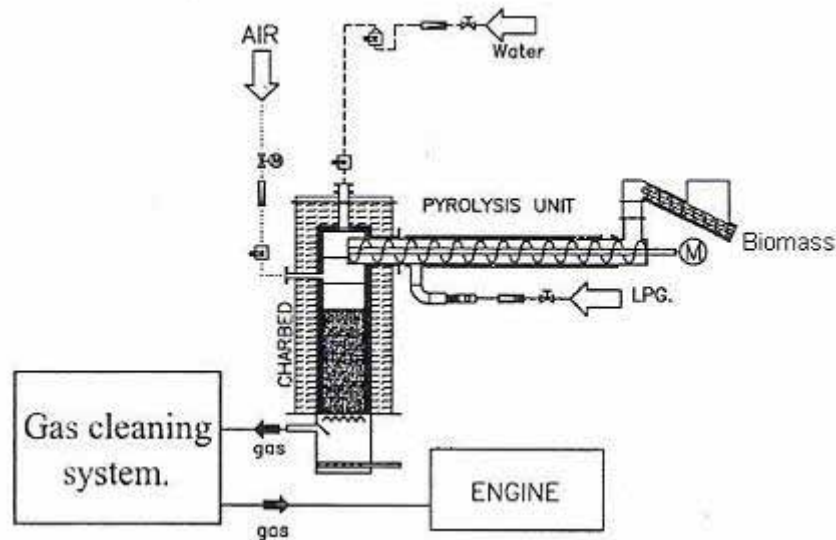

Fig. 10 Two-stage gasifier

Hindsgaul, *et al.*, (2000) investigated a two-stage gasifier of 100 kW consisting of an externally heated pyrolysis unit and a downdraft char gasifier for gasification of wood chips. The pyrolysis occurred at 600 °C and gasification at 1000 °C to 800 °C. The gasifying media was preheated steam air mixture. The gas was cleaned by venturi scrubber, demister (a steel sponge) and a filter. Under biomass: steam ratio of 1:1, the particle load was about 300 g/Nm<sup>3</sup>, and under ratio 3:1, the particle load increased above 1000 g/Nm<sup>3</sup>. The pressure drop through char bed was less when fuelled by briquettes than when fuelled by wood chips.

Filippis, *et al.*, (2004) proposed gasification of bagasse pellets of moisture content of about 11 % in a two-stage gasification reactor, which allowed for complete gasification avoiding the formation of carbon and tar. The reactor consisted of two stages, separated by the biomass feeder. Stage one was a reactor with a frit on the bottom side working as an updraft gasifier. Stage two was a fixed bed (high surface alumina or nickel on alumina) reforming reactor. The reactor was preheated and the feed was introduced in the reactor. It underwent immediate pyrolysis, and volatile component and char were formed. The char fell to the bottom of first stage, which reacted with the oxygen-steam (gasifying media) introduced through the frit. The gaseous mixture produced in stage one flowed up to stage two. In the second stage tar and heavy hydrocarbons were trapped in the bed, increased their residence time allowing for complete gasification and, if a reforming catalyst was used, also for complete reforming. The feed flow rate of bagasse was maintained constant at 0:80 g/min. The decrease in steam caused decrease in H<sub>2</sub>, and increase in CO<sub>2</sub> content in producer gas. The increase in temperature of stage one caused increase in CO and in CH<sub>4</sub> to a lesser extent. The presence of Ni (reforming and water shift catalyst) in stage two increased the reaction rate and CO and H<sub>2</sub> in the producer gas.

### 3.5 Crossdraft Gasification System

In this gasifier the fuel moves downwards while air is introduced on one side of the reactor and producer gas at 800-900 °C removed from the opposite side at the same level. Ash is removed from bottom. The overall energy efficiency is low and the tar content in producer gas is high and is mostly used in close-coupled boilers. A number of these gasifiers have been decommissioned in Brazil and South-American countries, as the fuel of acceptable quality

could not be produced on a sustainable basis. The tar cracking capability is limited therefore the gasifier is suitable only for low-tar fuels. Thus large-scale implementation of the cross draft gasifiers has not been done (Clarke, 1981; Reed and Das, 1988; Stassen and Knoef, 1993).

## 4. COMMERCIAL INSTALLATIONS OF FIXED BED GASIFIERS

Many countries have developed commercial biomass gasification technologies. Some of the commercially available fixed bed gasifiers are listed in Table 1.

Table 1. Few commercially available fixed bed gasifiers

Country	Type of fixed bed gasifiers	Fuel	Size	Organization / project
USA	Downdraft	Hogged wood, stumps	1 MW	CLEW
	Downdraft	Woodchips, corn cobs	40 kW	Stwalley Engg.
Denmark	Updraft	Hazardous, leather waste	2-15 MW	DTI
	Updraft	Straw, woodchips, bark	1-15 MW	VOLUND R&D Centre
	Downdraft	Wood residues	0.5 MW	Hollesen Engg.
New Zealand	Downdraft	Wood blocks, chips, coppice willow chips	30 kW	Fluidyne
France	Downdraft	Wood, agricultural residues	100-600 kW	Martezo
UK	Downdraft	Wood chips, hazel nut shells, MSW	30 kW	Newcastle University of technology
	Downdraft	Industrial agricultural wastes	300 kW	Shawton Engineering
Switzerland	Stratified	Woody and agricultural biomass	50-2500 kW	DASAG
	Downdraft	Wood, wood- waste	0.25-4 MW	HTV Energy
India	Downdraft	Wood chips, rice hulls	100 kg/h	Associated Engineering Works
	Downdraft	Wood stalks, cobs, shells, rice husk		Ankur Scientific Energy Technologies
Belgium	Small scale	Wood chips	160 kW	SRC Gazel
South Africa	Downdraft	Wood blocks, chips, briquettes	30-500 kW	SystBM Johansson gas producers
Finland	BIONEER updraft	Wood chips, straw, RDF pellets, peat	4-5 MW, 6.4 MW	Ahlstrom Corporation, VTT
Nether-	Downdraft	Rice husk	150 kW	KARA Energy Systems

S. Chopra and A. Jain. "A Review of Fixed Bed Gasification Systems for Biomass". Agricultural Engineering International: the CIGR Ejournal. Invited Overview No. 5. Vol. IX. April, 2007.

lands				
China	Downdraft	Sawdust	200 kW	Huairou wood equipment
	Downdraft	Crop residues	300 kW	Huantai Integrate Gas-supply System

Source: Ciferano and Marano, 2002 and Leung, *et al.*, 2004.

#### 4.1 Research Institutes Working on Biomass Gasification Systems

Some of the major research institutes working on gasification technologies of biomass are AIT, Thailand; Aston University, UK; Battele Columbus Laboratories, USA; Biomass Energy Foundation, USA; BTG, Netherlands; Delft University of Technology, Netherlands; CBMIG, Brazil; Chinese Academy of Agricultural and Mechanical Systems, China; Danish Technical University (DTU), Denmark; European Commission Directorate General for Energy, Belgium; IEA Bioenergy, USA; IGT, USA; IOWA State University, USA; IISC India; MNES, India; IIT, Bombay; TERI, India; Kansas State University, USA; KTH Sweden; Lund Institute of Technology, Sweden; NREL, USA; VIT Gasification R&D Centre, Finland; Vienna Technical University, Austria and Zaragoza University, Spain.

## 5. CONCLUSIONS

Biomass has high potential to contribute to energy needs of modern society worldwide. The fixed bed gasifier is the most practical option for production of a low calorific value gas for use in small-scale power generation schemes or thermal applications. The physical and chemical characteristics of biomass, capacity of gasifier and its intended application decides the choice of gasification system. The updraft gasifier is suitable essentially for thermal applications. The downdraft gasifier is suitable for both thermal and engine applications. The gasification of low-density biomass such as rice husk presents less problems in a throatless downdraft gasifier. The tar content can be minimized by separating pyrolysis and gasification zones as in two-stage gasifier. The commercial installations for fixed bed gasification systems have come up in many countries. The standardization of design and operating parameters of gasifiers, fuel processing and gas cleaning systems needs to be taken up to popularize small scale fixed bed gasification systems for decentralized thermal and power applications. The development in efficient utilization of biomass to meet energy needs will have dual advantage of reducing our dependence on commercial energy and protecting our environment. Although gasification technologies have recently been successfully demonstrated at small scale by the researchers and several demonstration projects are under implementation they still face economic and other non-technical barriers when trying to compete in the energy markets. This can be achieved via economic development through biomass systems integration. Thus the innovation in practically all demonstration projects under implementation lies not only on the technical aspects of the various processes but also in the integration of the gasification technologies in existing or newly developed systems.

## 6. REFERENCES

S. Chopra and A. Jain. "A Review of Fixed Bed Gasification Systems for Biomass". *Agricultural Engineering International: the CIGR Ejournal*. Invited Overview No. 5. Vol. IX. April, 2007.

- Altafini, C. R., P.R.Wander and R.M. Barreto. 2003. Prediction of the working parameters of a wood waste gasifier through an equilibrium model. *Energy Conversion and Management* 44:2763-2777.
- Barker, S.N. 1996. Gasification and pyrolysis- routes to competitive electricity production in the UK. *Energy Conversion and Management* 37(6-8):861-866.
- Barrio, M., M. Fossum and J. E. Hustad. 2001. A small-scale stratified downdraft gasifier coupled to a gas engine for combined heat and power production. In *Proc. 6<sup>th</sup> International Conference on Technologies and Combustion for a Clean Environment*, 1269-1276. Lisbon, Portugal, July.
- Bhattacharya, S. C., A. H. M. R. Siddique and H. L. Pham. 1999. A study on wood gasification for low-tar gas production. *Energy* 24:285–296.
- Brandt, P., E. Larsen and U. Henriksen. 2000. High tar reduction in a two-stage gasifier. *Energy and Fuels* 14:816–819.
- Bridgwater A. V., A. A. C. M. Beenackers and K. Sipila. 1999. *An assessment of the possibilities of transfer of European biomass gasification technology to China*. Report. EC DGXVIII Thermie Program. Aston University.
- Bui, T., R. Loof and S. C. Bhattacharya. 1994. Multi-stage reactor for thermal gasification of wood. *Energy* 19(4):397–404.
- Carlos, L. 2005. High temperature air/steam gasification of biomass in an updraft fixed batch type gasifier. Ph.D. thesis. Royal Institute of Technology, Energy Furnace and Technology, Stockholm, Sweden.
- Ciferano, J. P. and J. J. Marano. 2002. Benchmarking biomass gasification technologies for fuels, chemicals and hydrogen production. U.S. Department of Energy. National Energy Technology Laboratory.
- Clarke, S. J. 1981. Thermal biomass gasification. *Agricultural Engineering* 62(5):14-15.
- Dasappa, S., H. V. Sridhar, G. Sridhar, P. J. Paul and H. S. Mukunda. 2003. Biomass gasification – a substitute to fossil fuel for heat application. *Biomass Bioenergy* 23:637–649.
- Dasappa, S., P. J. Paul, H. S. Mukunda, N. K. S. Rajan, G. Sridhar and H.V. Sridhar. 2004. Biomass gasification technology – a route to meet energy needs. *Current Science* 87(7):908-916.
- Demirbas, A. 2002. Hydrogen production from biomass by the gasification process. *Energy Sources* 24:59-68.
- Dogru, M., A. Midilli, G. Akay and C. R. Howarth. 2004. Gasification of leather residues-part I. Experimental study via a pilot scale air blown downdraft gasifier. *Energy Sources* 26:35-44.
- Dogru, M., C. R. Howarth, G. Akay, B. Keskinler and A. A. Malik. 2002. Gasification of hazelnut shells in a downdraft gasifier. *Energy* 27:415-427.
- Filippis, P. D., C. Borgianni, M. Paolucci and F. Pochetti. 2004. Gasification process of Cuban bagasse in a two-stage reactor. *Biomass and Bioenergy* 27:247-252.
- Ghosh, S., T. K. Das and T. Jash. 2004. Sustainability of decentralized woodfuel-based power plant: an experience in India. *Energy* 29:155-166.

- Hindsgaul, C., J. Schramm, L. Gratz, U. Henriksen and J.D. Bentzen. 2000. Physical and chemical characterization of particles in producer gas from wood chips. *Bioresource Technology* 73:147-155.
- Jain, A. Design parameters for a rice husk throatless gasifier. 2006. *Agricultural Engineering International: the CIGR Ejournal*, Manuscript EE 05 012. Vol VIII.
- Jain, A. K. 1996. *Producer gas technology*. Report for IX annual workshop of all India co-ordinated research project on renewable energy sources for agriculture and agro-based industries. PAU, Ludhiana, India.
- Jain, A. K. and J. R. Goss. 2000a. Determination of reactor scaling factors for throatless rice husk gasifier. *Biomass and Bioenergy* 18:249-256.
- Jain, A. K., 1997. Correlation models for predicting heating value through biomass characteristics. *Journal of Agricultural Engineering* 34(3):12-25.
- Jain, A. K., S. K. Sharma and D. Singh. 2000b. Designing and performance characteristics of a throatless paddy husk gasifier. *J Agril. Issues* 5:57-67.
- Jayah, T. H., L. Aye, R. J. Fuller and D. F. Stewart. 2003. Computer simulation of a downdraft wood gasifier for tea drying. *Biomass and Bioenergy* 25:459-469.
- Jorapur, R. and A.K. Rajvanshi. 1997. Sugarcane leaf-bagasse gasifiers for industrial heating applications. *Biomass and Bioenergy* 13(3):141-146.
- Kucuk, M. M. and A. Demirbas. 1997 Biomass conversion processes. *Energy Conversion and Management* 38:151-165.
- Kutz, L. J., J. R. Barrett, C. B. Richey and R. B. Jacko. 1983. Downdraft channel gasifier operation and particulate emissions. *Transactions of the ASAE* 1614-1618.
- Leung, D. Y. C., X. L. Yin and C. Z. Wu. 2004. A review on the development and commercialization of biomass gasification technologies in China. *Renewable and Sustainable Energy Reviews* 8:565-580.
- Liinanki, L., P. J. Svenningsson and G. Thessen. 1985. Gasification of agricultural residues in a downdraft gasifier. 2<sup>nd</sup> International Producer Gas Conference, Bandung, Indonesia.
- Loewer, O. J., R. J. Black, R. C. Brook, I. J. Ross and F. Payne. 1982. Economic potential of on-farm biomass gasification for corn drying. *Transactions of ASAE* 779-784.
- Mckendry, P. 2002. Energy production from biomass (part 3): gasification technologies. *Bioresource Technology* 83:55-63.
- Midilli, A., M. Dogru, C. R. Howarth, M. J. Ling and T. Ayhan. 2001. Combustible gas production from sewage sludge with a downdraft gasifier. *Energy Conversion and Management*. 42:157-172
- Midilli, A., M. Dogru, G. Akay and C. R. Howarth. 2004. Gasification of leather residues-part II. Conversion into combustible gases and effects of some operational parameters. *Energy Sources* 26:45-53.
- Milne, T. A. and R. J. Evans. 1998. Biomass gasification “tars”: their nature, formation and conversion. NREL, Golden, CO, USA, Report no. NREL/TP-570-25357.

- Mukunda, H. S., S. Dasappa, P. J. Paul, N. K. S. Rajan and U Shrinivasa. 1994. Gasifiers and combustors for biomass—technology and field studies, *Energy for Sustainable Development*. 1(3):27-38
- Na, J. I., S. J. Park, Y. K. Kim, J. G. Lee and J. H. Kim. 2003. Characteristics of oxygen-blown gasification for combustible waste in a fixed-bed gasifier. *Applied Energy* 75:275-285.
- Pathak, B. S. 2005. Biomass to power rural development. In *Proc. of National Seminar on Biomass Based Decentralized Power Generation*, ed. B.S.Pathak and N.S.L. Srivastava, 1-6. Vallabh Vidhyanagar: Sardar Patel Renewable Energy Research Institute.
- Payne, F. A., I. J. Ross, J. N. Walker and R. S. Brashear. 1983. Exhaust analysis from gasification-combustion of corncobs. *Transactions of the ASAE* 246-249.
- Rajvanshi, A. K. 1986. Biomass gasification. In *Alternative energy in agriculture Vol. II*, ed. D. Y. Goswami, 83-102. CRC Press.
- Rao, M. S., S. P. Singha, M. S. Sodha, A. K. Dubey and M. Shyam. 2004. Stoichiometric, mass, energy and exergy balance analysis of countercurrent fixed-bed gasification of post-consumer residues. *Biomass and Bioenergy* 27:155-171.
- Reed, T. B. and A. Das. 1988. *Handbook of biomass downdraft gasifier engine systems*. Colorado: Solar Energy Research Institute.
- Riva G. 2006 . Utilisation of Biofuels on the Farm. *Agricultural Engineering International: the CIGR Ejournal*. Invited Overview No. 15. Vol. VIII.
- Sasidharan, P., K. P. Murali and K. Sasidharan. 1995. Design and development of ceramic-based biomass gasifier-an R&D study from India. *Energy for Sustainable Development* Vol. II, 4:49-52
- Sheng, G. X. 1989. Biomass gasifiers: from waste to production. *Biomass* 20:3-12.
- Sims R. 2003. Climate Change Solutions From Biomass, Bioenergy and Biomaterials. *Agricultural Engineering International: the CIGR Journal of Scientific Research and Development*. Invited Overview. Vol. V.
- Singh, R. N., U. Jena, J. B. Patel and A. M. Sharma. 2006. Feasibility study of cashew nut shells as an open core gasifier feedstock. *Renewable Energy* 31(4): 481-487.
- Sokhansanj S., J. Cushman, and L. Wright. 2003. Collection and Delivery of Feedstock Biomass for Fuel and Power Production. *Agricultural Engineering International: the CIGR Journal of Scientific Research and Development*. Invited Overview. Vol. V.
- Stassen, H. E. M and H. A. M. Knoef. 1995. UNDP/WB small-scale biomass gasifier monitoring programme—final findings. *Energy for Sustainable Development* Vol. II(1): 41-48.
- Stassen, H. E. M. and H. A. M. Knoef. 1993. Small-scale gasification systems. The Netherlands: Biomass Technology Group, University of Twente.
- Tiangco, V. M., B. M. Jenkins and J. R. Goss. 1996. Optimum specific gasification rate for static bed rice hull gasifiers. *Biomass and Bioenergy* 11(1):51-62.
- Tiwari G., B. Sarkar, and L. Ghosh. 2006. Design Parameters for a Rice Husk Throatless Gasifier Reactor. *Agricultural Engineering International: the CIGR Journal of Scientific Research and Development* Manuscript EE 05 012. Vol. VIII.

- VTT. 2002. *Review of Finnish biomass gasification technologies*. OPET Report No. 4. Technical research centre of Finland, Finland.
- Wander P. R., C. R. Altafini and R. M. Barreto. 2004. Assessment of a small sawdust gasification unit. *Biomass and Bioenergy*. 27:467-476.
- Warren T. J. B., R. Poulter and R. I. Parfitt. 1995. Converting biomass to electricity on a farm-sized scale using downdraft gasification and a spark-ignition engine. *Bioresource Technology* 52:95-98.
- Yang W., A. Ponzio, C. Lucas and W. Blasiak. 2006. Performance analysis of a fixed-bed biomass gasifier using high-temperature air. *Fuel Processing Technology* 87:235-245.
- Zhou X., R. Dong, S. Li, G. Peng, L. Zhang, J. Hou, J. Xiao, and B. Zhu. 2003. Agricultural Engineering in China. *Agricultural Engineering International: the CIGR Journal of Scientific Research and Development*. Invited Overview Paper.