

Approved for public release; distribution is unlimited.

A BIOLOGICAL MODEL FOR DIRECTIONAL SENSING OF SEISMIC VIBRATION

R. N. Miles
Department of Mechanical Engineering
State University of New York
Binghamton, NY 13902-6000
Miles@binghamton.edu

R. B. Cocroft
Division of Biological Sciences
University of Missouri
Columbia, MO 65211

ABSTRACT

There are many applications for a compact device that is capable of indicating the direction of propagation of substrate vibration. In order to develop effective devices for this purpose, it can be helpful to examine biological systems that have evolved specialized sensory systems for finding a vibration source. We are studying an insect model of vibration localization that provides an approach to directional vibration sensing over very small spatial scales. The treehopper *Umbonia crassicornis* communicates using vibrational signals transmitted along plant stems in the form of bending waves. The insect detects these substrate vibrations using sensors in the legs. Because the legs in this small species span a distance along the stem of only 5 mm, the insect is faced with a difficult localization problem: time-of-arrival differences between receptors on different legs are in the microsecond range, and wavelengths are an order of magnitude larger than the insect's own dimensions. To study this system we constructed a simulator that mimics the surface motion of propagating bending waves, then used the simulator to explore directional sensing mechanisms. Using laser vibrometry, we characterized the dynamic response of the insect's body (analogous to a mass on a set of springs) when driven with vibration of the substrate. We found a remarkable mechanical directionality in the response of the insect's body to substrate vibration, in which small time differences are converted to large amplitude differences across the insect's body. Preliminary evidence suggests that directionality results from the interaction of two modes of vibration in the insect's body: one that responds to the spatial gradient of the vibrational signal, and one that responds to the spatial average of the signal over the region sampled. This system generates a marked directionality in the amplitude response of the insect's body while sampling only 5 mm of a vibration gradient. We believe that a directional sensing system based on this insect model has direct applications to localization of other surface waves, such as those propagating along the surface of the ground.

1.0 INTRODUCTION

Many small animals must deal with the problem of localizing sound and vibration sources for mate selection and predator avoidance (reviewed in Cocroft et al., 2000). As in man-made systems, these animals must process differences in the signals detected at spatially separated sensory organs to identify the direction of propagation. Large animals such as humans, with ears located on either side of the head, can detect and process interaural differences in intensity and arrival time to identify the source location. Very small animals such as insects and spiders, however, must localize signals that contain wavelengths many times longer than their own dimensions. Their small size precludes use of sensors far enough apart to detect significant signal differences, and as a result they are faced with minute time and amplitude differences between receptors. Furthermore, they must make do with relatively modest signal processing capabilities in their central nervous systems.

For insects, vibrations traveling through the substrate provide one of the most important sources of information about the environment (Markl 1983; Henry, 1994; Stewart 1997). To use this information in finding mates, capturing prey, or avoiding predators, it is often necessary to locate the vibration source. As in acoustic sensing, large species can use time and amplitude differences among receptors to determine the direction of a propagating

wave (Barth 1998). However, most species of insects that use substrate vibrations in social and ecological interactions are very small, with dimensions only a small fraction of the wavelengths used. How these species localize vibration sources remains a fundamental problem in bioacoustics, and overcoming the current limits of our understanding will require an integration of engineering and biology.



We are examining a system that shows great promise for understanding directional mechanisms in vibration sensing. Our model system is a treehopper, *Umbonia crassicornis*, shown in figure 1. This small insect communicates using vibrational signals transmitted through the stems of plants (Cocroft 1996, 1999a,b). In our previous collaboration, we discovered a novel means of vibrational directionality in this species. Large, directional amplitude differences (10 dB) are created by the biomechanical response of the insect's body to substrate vibration (Cocroft et al., 2000). We are investigating the mechanical principles underlying this remarkable directional mechanism, as well as the insect's strategies for using this information for vibrational homing in complex vibrational environments.

Figure 1. The treehopper *Umbonia crassicornis* on a host plant stem. The insect is approximately 1 cm long.

The pattern emerging from our studies of both sound (e.g., Miles et al., 1995) and vibration localization in small insects is that enhancement of directional cues is accomplished by a form of mechanical pre-processing. This passive, mechanical approach to the design of small directional sensors is ideally suited to modern fabrication techniques based on silicon micromachining. An important feature of all insect sensory systems is that they must be quite small, owing to the relatively small stature of most insects. The design constraints of small size and high sensitivity also pose great challenges in the development of new acoustic and vibration sensors. One of our labs (R. Miles) is using insights from our studies of acoustic sensing systems to design innovative smart microsensors for localizing a sound source. We are now poised to extend this work to solve problems of localizing sources of substrate vibration.

2.0 VIBRATION SENSING IN INSECTS

Insects, spiders and their relatives perceive vibration through receptors in their legs, which are in contact with the substrate (Kalmring 1985). Studies of vibration localization on solid substrates have been limited to large species of insects, spiders and scorpions with legs spanning 5-10 cm (Brownell and Farley 1979; Cokl et al. 1985). In these species, differences in arrival time and amplitude at different legs are large enough to provide readily accessible directional information. However, species using vibrations in social and ecological interactions span more than two orders of magnitude in size (Gogala 1985; Henry 1994; Stewart 1997), and the mechanisms found in large species do not translate directly to smaller scales. Mechanisms of vibration localization in small species, which experience microsecond time delays and minuscule amplitude differences between inputs, are not currently understood.

We have developed a study system that provides an excellent bioassay for directionality in small insects. Many insects use vibrations traveling through the stems and leave of plants for communication and for the detection of predators and prey (Henry 1994; Stewart 1997). These signals are transmitted in the form of bending waves (Michelsen et al. 1982; Barth 1998; Cocroft et al., 2000). Vibrational signals play a critical role in the biology of our study species (Cocroft 1996, 1999 a,b, 2001), and localization of the source of a vibrational signal is important in reproduction and survival. Adult male treehoppers search for mates by producing a complex vibrational signal that travels through the plant. If a receptive female is present, she responds with a vibrational signal of her own. The male then homes in on the female to mate with her, localizing her by means of her vibrational signals. Speed and accuracy are important, because there is competition among all of the males on the plant to be the first to locate the female. The male's localization behavior can be easily studied, because males will respond vigorously to vibrational playback of natural female signals.

Homing is a complex task for a male treehopper, because females may be detected at ranges of up to 1-2 m away on a heterogeneous, branching structure. The male is about 1 cm long, with legs (and thus vibration sensors) separated by a maximum of 5 mm front-to-back. Most of the energy in the female signals is at about 100 Hz. With a phase propagation velocity of bending waves of about 15 m/s for a 100-Hz signal on a typical host plant, the signal wavelength will be about 15 cm. The male must therefore localize a signal whose wavelength is 30 times longer than the distance between his vibration sensors. However, male treehoppers do locate females. In fact, accurate directional abilities have been demonstrated in an even smaller species, in which receptors are separated by only 2-3 mm (Cocroft, in prep). Treehoppers have therefore clearly solved the problems of localization, but the mechanisms underlying this ability are only now coming to light.

3.0 CHARACTERIZING AND REPRODUCING THE VIBRATIONAL ENVIRONMENT

To investigate an insect's mechanical and behavioral responses to substrate vibration, it is necessary to be able to both describe and reproduce its natural vibratory environment. In principle, a number of distinct vibrational wave types can be produced in a rod-like structure such as a plant stem (Cremer and Heckl, 1988). However, only one of these -- bending waves -- has been found to be

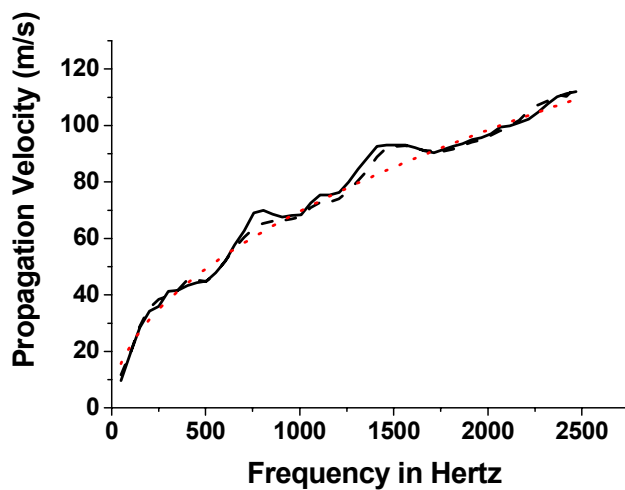

important for insects using plant-borne vibrations (reviewed in Cocroft et al., 2000). Our study was the first to measure the propagation velocity of natural insect signals, and our results were consistent with previous studies using mechanically induced vibrations (Michelsen et al. 1982; Barth 1998). Figure 2 shows the phase propagation velocity of a treehopper signal in a stem, with the typical dispersive propagation characteristic of bending waves.

Figure 2. Propagation velocity measurements of signals produced by female *U. crassicornis* on a host plant stem.

To reproduce the surface moments of propagating bending waves, we designed a bending wave simulator (Fig. 3) consisting of a short length of dowel controlled by a pair of piezoelectric actuators (the design of this simulator, and the relevant background theory, are discussed in Miles et al., 2001). The actuators are driven with random noise signals with specified phase relationships that create the slope and displacement of bending waves propagating along a beam (Fig. 4). This simulator thus replicates not only the physical dimensions of natural substrates, but also the vibrational environment of an insect on that substrate. Development of this simulator provides an important new tool for investigating the mechanics of vibration sensing in insects.



Figure 3. Stem simulator used to characterize the treehopper's mechanical response to substrate vibration.

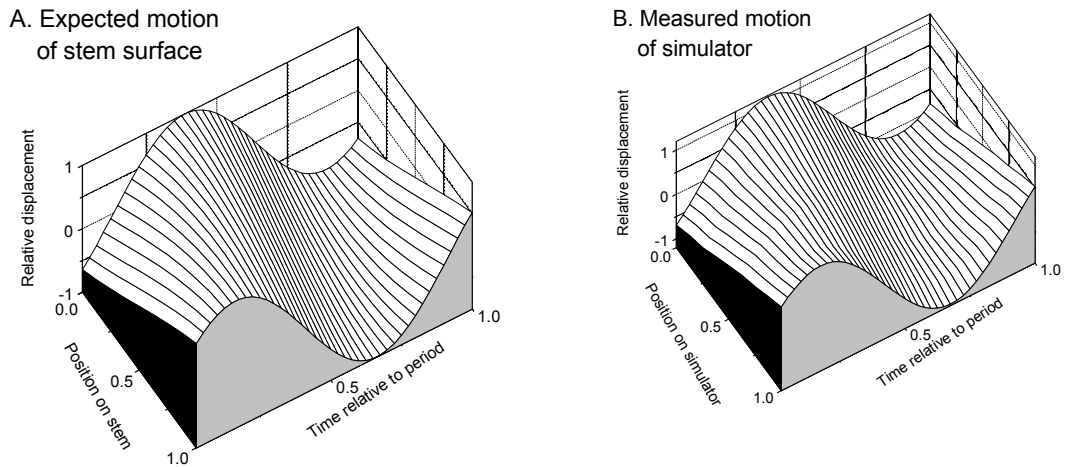

Figure 4. Performance of the stem simulator. A. Motion of surface expected in an ideal beam with propagating bending waves. B. Motion of surface of dowel measured with laser vibrometer.

4.0 DIRECTIONAL SENSING IN THE TREEHOPPER

We use laser Doppler vibrometry to make non-invasive measurements of the insect and the substrate. Our experimental setup is shown in Figure 5, with the laser beam parallel to the plane of motion of the simulator and the lens approx. 20 cm in front of the vertical dowel segment. Using this system, we can characterize the mechanical response of an intact, unrestrained insect on an appropriate substrate. Our approach is to simulate bending motion of the substrate over the frequency range present in the insect's signals (most energy is in the 100-200 Hz range, with some energy present up to 4 kHz). We place an insect in the center of the dowel where, because of its sedentary lifestyle, it will usually remain for an extended period (up to 30 min or more). We then drive the simulator with a random noise signal (maximum frequency = 4 kHz) with the appropriate phase delays between the two actuators. This allows us to reproduce bending wave motion first in one direction, then the other. That is, the insect experiences the motion due to propagating bending waves originating first from in front, then from behind.

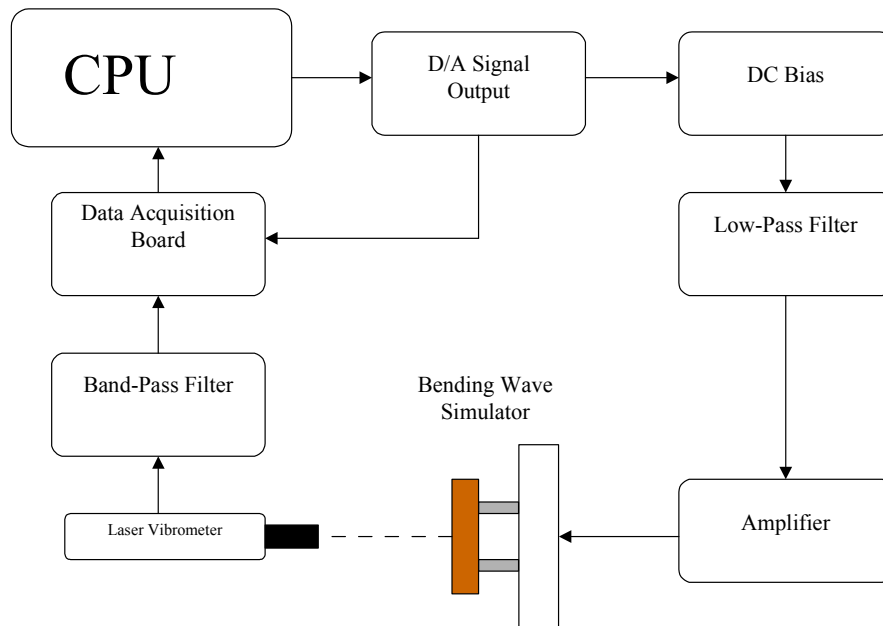

Figure 5. Experimental Setup for the Bending Wave Simulator

Results of our previous studies are presented in detail in Cocroft et al. (2000) and Miles et al. (2001); however, we here briefly describe our experiments and results. For each individual insect, we measured points along the long axis of the body (Figure 6). We also measured three points on the dowel (one just in front of the insect, one just behind it, and one near the insect's middle leg). The points measured on the substrate allow us to normalize the response of the insect's body relative to the substrate. We then calculate transfer functions between the signal measured on the substrate and the signal measured on the insect.

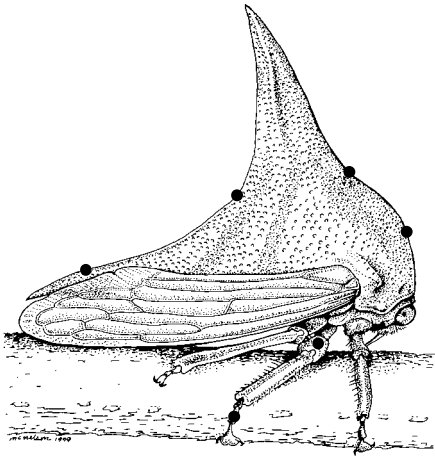
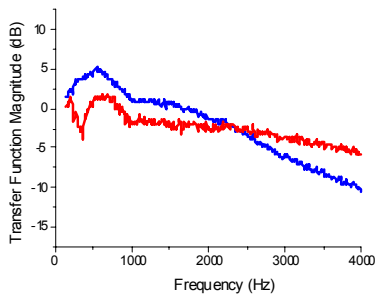

Figure 6. Female *U. crassicornis* in a typical position on a host plant stem. Black dots indicate locations of vibration measurements made using a laser vibrometer. The front of the body is to the right.

Importantly, the mechanical response of the body relative to the substrate differed depending on the stimulus direction.

Figure 7 shows the relative motion of the front and back of the insect's body. When the wave originated in front of the insect, the two locations had a similar amplitude spectrum; however, when the wave originated behind the insect, the amplitude was greater at the posterior end at all frequencies.

A. Wave traveling front to back



B. Wave traveling back to front

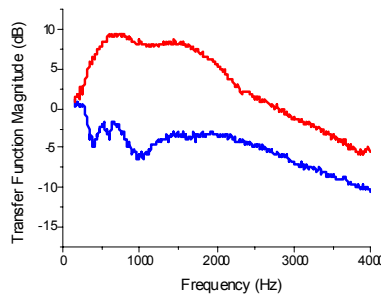

Thus, the mechanical response of the insect's body converts small time differences between inputs into large amplitude differences at different points on the body.

Figure 7. Directional changes in motion of the treehopper's body relative to the substrate. Blue: front of body; red:

back of body. Relative motion differs by over 10 dB for stimuli from opposite directions.

5.0 CURRENT RESEARCH DIRECTIONS

The vibrational environment:

Current research aims at extending our understanding of the vibratory environment of insects. Previous studies have shown the possibility of reflected and standing waves in plant stems, as well as unpredictable patterns of amplitude decay at increasing distances from the source (Michelsen et al., 1982). However, no study has characterized the propagation patterns of the entire transmission pathway over which an insect must home in on a signal. This knowledge is critical for understanding the behavioral sampling strategies that have evolved to allow a small insect to home in on a vibration source in a complex vibrational environment. Describing the mechanics of a complex structure like a plant is not a trivial task, but the R. Miles lab has extensive experience in this area. The work will be done in the R. Cocroft laboratory, using the two-laser measuring system and in consultation with the R. Miles laboratory. To examine a range of natural plant environments, we will use 3 host plant species that differ in structural characteristics (including branching patterns and stem properties that influence transmission range and propagation velocity). Saplings 1-1.5 m tall will be obtained from nurseries or grown in the greenhouse. These data will enable us to characterize general patterns of amplitude decay within plant structures, as well as to quantify the influence of reflections and standing waves.

Sampling strategies and decision-making in complex vibrational environments:

A plant constitutes a heterogeneous transmission channel with a complex three-dimensional geometry. Studies of vibration transmission along plant stems have revealed the presence of reflections, standing waves, and unpredictable amplitude peaks (Michelsen et al. 1982; Barth et al. 1988). Insects that use plant-borne vibrations thus provide a useful model system for the problem of vibration localization in complex environments. Once we have characterized the vibrational properties of natural plants, we will use what we know about the vibrational environment to understand the insects' decision-making process. Rather than using a random noise signal, we will now use natural signals that elicit homing responses in the insects. We will describe the insects' localization behavior in three contexts: on the bending wave simulator; on stems with a single Y-branch; and on saplings with complex branching patterns.

The vibrational localization behavior of treehoppers provides an excellent bioassay for understanding sampling strategies, because individuals alternate periods of movement with clearly defined stopping points at which their directional information is updated and a new decision is made. By tracking these decision points, we can reconstruct the information that was available at each point. To do this, we will videotape the insect responding to the playback, then use the laser to characterize the local vibration environment at the decision point. We can then correlate the vibration characteristics of the local region with the insect's subsequent decision of which direction to move.

Locating a vibration source is often necessary for survival and reproduction in these insects, and their abilities and localization strategies have been optimized by millions of generations of natural selection. We aim to provide a picture of how a single, small individual integrates information from point samples of a series of local environments in order to arrive at a vibration source, as well as the sampling rules that optimize homing success. Our results will have implications for the deployment of mobile devices that incorporate directional sensing and sequential sampling strategies to find a vibration source.

Mechanical modeling:

An insect resting on its six legs is analogous to a mass on a set of springs, and will have a characteristic response when driven by vibration of the substrate. In our previous collaboration, we characterized this response using free-standing insects on the bending-wave simulator. We drove the simulator with a random signal, and measured the transfer function between the substrate and the insect's body with laser Doppler vibrometry. As expected for a mass-and-spring system, we found that the body vibrations follow the substrate at low frequencies, show resonance at intermediate frequencies, and attenuation at higher frequencies. Furthermore, we found that the response properties of the body differed significantly depending on stimulus direction (see above Fig. 7). When the signal originates in front of the insect, the responses of the front and back of the body are similar. However, when the signal originates behind the insect, the response is substantially higher at the back. The biomechanical response of the insect's body thus converts the small amplitude and phase differences among the legs into substantial amplitude differences. These amplitude differences provide an elegant mechanism for directionality.

We propose to investigate the mechanical principles underlying this remarkable directional response. How might this directionality arise? Given a system with two modes, one mode that responds to the spatial gradient of the quantity being detected and one that responds to the spatial average of the signal over the region sampled, the mechanical response of the system can differ significantly depending on the direction of propagation of the signal. The two modes can combine to convert a small phase difference across the region into a large amplitude difference at various points on the structure (Gerzon 1994). We observed both a translational mode and a rotational mode in the movement of the insect's body relative to the substrate (Fig 8), and it is likely that the interaction of these modes is responsible for the mechanical directionality of the body.

We hope to use insights from our studies of this vibrational sensing system to design innovative smart microsensors for localizing sources of vibration. This will involve the development of analytical models of potential sensor concepts based on a lumped parameter approach. Having demonstrated that the general sensor concepts are reasonable, we can develop detailed finite element models of candidate structures that could be fabricated using silicon microfabrication technology.

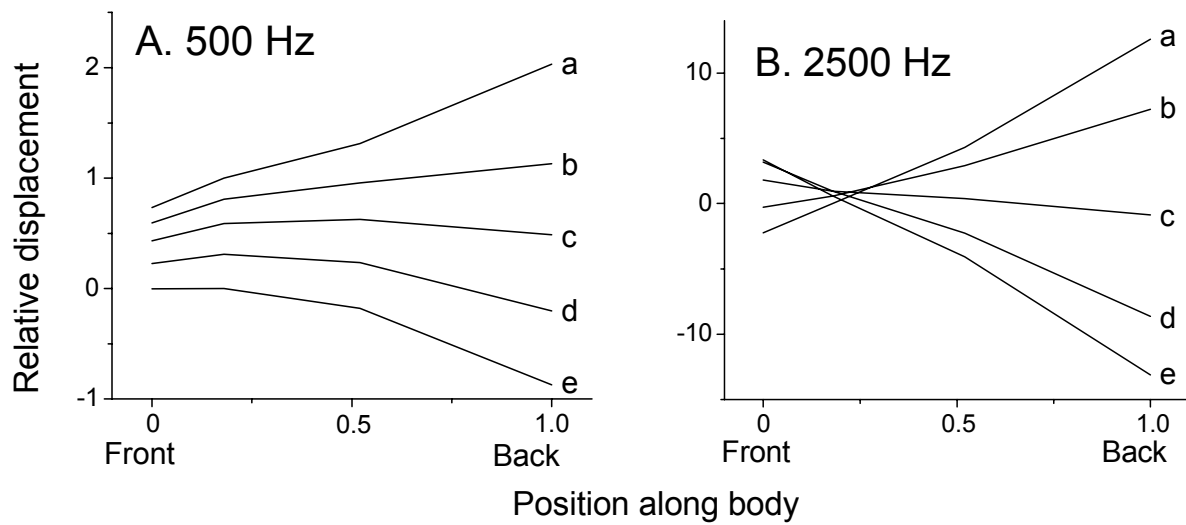

Figure 8. Modes of vibration of the treehopper's body. Each line represents motion of the body as a whole, at sequential time intervals (a-e) equally spaced through one-half of a cycle. A. Translational mode; B. Rotational mode. The back of the body moves with greater amplitude in each case.

6.0 REFERENCES

- Barth, F. G. 1998. The vibrational sense of spiders. Pp. 228-278 in: *Comparative Hearing: Insects*, Hoy, RR, Popper, A. N., and Fay, R. R. (eds.), *Springer Handbook of Auditory Research*, series editors Fay, R. R. and Popper, A. N. Springer, NY.
- Brownell, P. H. and Farley, R. D. 1979. Orientation to vibrations in sand by the nocturnal scorpion *Paruroctonus mesaensis*: mechanism of target localization. *J. Comp. Physiol.* 131:31-38.
- Cocroft, R. B. 1996. Insect vibrational defense signals. *Nature* 382: 679-80.
- Cocroft, R. B. 1999a. Offspring-parent communication in a subsocial treehopper (Hemiptera: Membracidae: *Umbonia crassicornis*). *Behaviour* 136:1-21.
- Cocroft, R. B. 1999b. Parent-offspring communication in response to predators in a subsocial treehopper (Hemiptera: Membracidae: *Umbonia crassicornis*). *Ethology* 105:553-568.
- Cocroft, R. B., T. D. Tieu, R. R. Hoy, and R. N. Miles. 2000. Directionality in the mechanical response to substrate vibration in a treehopper (Hemiptera: Membracidae: *Umbonia crassicornis*). *J. Comp. Physiol.* 186: 695-705.
- Cokl, A., Otto, C. and Kalmring, K. 1985. The processing of directional vibratory signals in the ventral nerve cord of *Locusta migratoria*. *J. Comp. Physiol. A* 156:45-52.
- Cokl, A., M. Virant-Doberlet, and A. McDowell. 1999. Vibrational directionality in the southern green stink bug, *Nezara viridula* (L.), is mediated by female song. *Anim. Behav.* 58:1277-1283
- Cremer, L. and Heckl, M. 1988. *Structure-borne sound: Structural vibrations and sound radiation at audio frequencies*, 2nd ed. Springer Verlag, Berlin.
- Gerzon, M. A. 1994. Applications of Blumlein shuffling to stereo microphone techniques. *J. Audio Eng. Soc.* 42:435-453.
- Henry, C. S. 1994. Singing and cryptic speciation in insects. *Trends Ecol. Evol.* 9:388-392.
- Kalmring, K. 1985. Vibrational communication in insects (reception and integration of vibratory information), in Kalmring, K, and Elsner, N (eds.), *Acoustic and Vibrational Communication in Insects*. Verlag Paul Parey, Berlin.
- Markl, H. 1983. Vibrational Communication, Pp. 332-353 in: Huber, F. and Markl, H (eds.), *Neurobiology and Behavioral Physiology*, Springer Verlag, Berlin.
- Michelsen, A., Fink, F., Gogala, M. and Traue, D. 1982. Plants as transmission channels for insect vibrational songs. *Behav. Ecol. Sociobiol.* 11:269-281.
- Miles, R.N. Robert, D., and Hoy, R. R. 1995. Mechanically coupled ears for directional hearing in the parasitoid fly *O. ochracea*. *J. Acoustical Soc. America* 98:2059-2070.
- Miles, R. N., Cocroft, R. B., Gibbons, C. and Batt, D. 2001. A bending wave simulator for investigating directional vibration sensing in insects. *J. Acoustical Soc. America* (*in press*).
- Stewart, K. W. 1997. Vibrational communication in insects: epitome in the language of stoneflies? *Amer. Entomol. Summer* 1997:81-91.