

Physics and Chemistry of Aging – Early Developments⁺

J.Va'vra*

Stanford Linear Accelerator Center, Stanford, CA 94309, USA

Abstract

The aging phenomena are very complex physical and chemical processes. The author attempts to qualitatively discuss various physical processes contributing to aging. The satisfactory quantitative explanation is not presently available. In this sense, there is little progress made since the 1986 LBL Aging Workshop. However, what was accomplished during the past decade is a heightened awareness from the research and management sides to pay more attention to this problem, and as a result a number of aging tests have increased in quantity and quality. These efforts will undoubtedly yield some new results in the future. Examples in this paper are mainly from a “pre-LHC and pre-HERA-B era of aging,” where the total charge doses is limited to much less than one C/cm.

1. Introduction

When I talk about aging, I refer to the general deterioration of the detectors during their operation, i.e., I do not restrict to usual wire aging which typically creates anode wire coating. The aging phenomenon is very complex. A multi-layer structure of an onion is a good model to describe it, where each particular process is on a separate layer. There are simply too many variables in the problem, and therefore, it is too naive to expect that one can express the aging rate using simple-minded variables, such as the accumulated charge per length of wire, etc. The correct variables include the cross-sections, the electron or photon energies, the electrostatic forces, the dipole moments, the chemical reactivity of atoms and molecules, etc. Presently, we do not know the relationship between the microscopic and the macroscopic variables we can control. Therefore, it is difficult to truly understand any aging measurements quantitatively from the physics point of view. At best, we can describe it qualitatively and measure some systematic dependencies. The aim of this workshop is quite modest, as we want to find a simple practical remedy for each particular process on a single layer of an onion, even if we might not understand the full problem.

Plasma chemistry is the closest branch of science, which can shed some “practical” light on the detector aging phenomena. This was already realized before the 1986 LBL Aging Workshop [1], and a search was under way to correlate the aging phenomena with plasma chemistry observations (see, for example, references 2 and 3). Apart from similarity of the energy range of electrons, the operating parameters are quite different [2], and therefore it would appear that one couldn't share

⁺ Invited talk at the International Workshop on Aging Phenomena in Gaseous Detectors, DESY, Hamburg, Germany, October 2-5,2001

* Work supported by the Department of Energy under contract DE-AC03-76SF00515.

the experiences significantly. Yet, in retrospect, some plasma chemistry conclusions proved to be directly applicable to our field, at least qualitatively. Some examples include a beneficial role of oxygen, oxygen-based molecules such as water or alcohol or DME, CF₄, etc. Still, one cannot apply them religiously, because additives in some applications simply do not work, or may be even harmful. It seems to me that if plasma chemistry is to contribute directly to high-energy physics detector field, it may have to allocate more time to operate tests under very similar conditions, i.e., at one bar of pressure instead of at a few Torr, using similar gases, etc.

2. Important Physics Processes Involved in Aging Phenomena

I will discuss qualitatively some of the most typical physical processes, which play an important role in the aging phenomena.

2.1. Production of γ 's

Photons are responsible for the secondary electron emission processes, which can result in the positive feedback mechanisms or avalanche growth (avalanche breeding). Typical processes responsible for the photon production are:

- electron-atom collisions in the avalanches ($e^- + A \rightarrow e^- + A^* \rightarrow e^- + A + \gamma$),
- positive ion-electron recombination at the cathode ($A^+ + \text{Cathode } (e^-) \rightarrow A + \gamma$,

$$E_\gamma = E_{\text{ioniz.potential}} - E_{\text{work function}},$$

- positive ion-electron recombination in the avalanches ($e^- + A^+ \rightarrow A^* + \gamma, E_\gamma = E_e + (E_i - E_k)$).

2.2. Secondary Electron Emission

The secondary electron emission processes are responsible for the creation of positive feedback mechanisms. These processes are especially devastating as they can rapidly increase the total deposited charge dose in the advanced stages of aging. The secondary electrons can play a similar role as the secondary neutrons in the U²³⁵ fission. Their typical examples and characteristic signatures are (the way in which we can recognize them, for example, on an oscilloscope):

- photons, generated during the ion-electron recombination at the cathode, produce secondary electrons through photoeffect or via a photosensitive film developed on the cathode (signature: the primary pulse is followed by secondary pulses, which are delayed by a long delay due to the slow drift of positive ions);
- avalanche photons, caused for example by carbon excitations ($e^- + C \rightarrow C^* + \gamma, E_\gamma \sim 156, 166, 193 \text{ nm}$), interacting with the cathode surface (signature: the primary pulse is followed by secondary pulses with a short delay);

- avalanche photons interacting with the gas; for example, CF_4 gas mixed with TMAE ($e^- + \text{CF}_4 \rightarrow (\text{CF}_3^+)^* \text{ or } + (\text{CF}_4^+)^* \rightarrow \gamma, E_\gamma \sim 160 \text{ nm}, \text{ and } E_\gamma + \text{TMAE} \rightarrow \text{TMAE}^+ + e^-$ [4,5])
(signature: the primary pulses start growing in amplitude and time);
- emission on sharp points on the cathode (signature: a very steep gain-voltage characteristic with a steep threshold behavior),
- the Malter effect [6], which is a “classical” positive feedback established between the amplification and the secondary electron emission from the cathode (signature: the current starts as single electrons and can grow up to hundreds of nA. The effect is very localized. It can be persistent even after the source of radiation is removed, if the positive feedback is strong).

Although, one can observe the secondary effects with an oscilloscope, a quantitative statistical method to recognize onset of the secondary effects is to measure the single-electron pulse height spectra using a UV lamp creating photoelectrons off the electrodes. A chamber suffering from a large rate of the cathode secondary effects will show excessive tail in such distribution [4]. To illustrate this phenomenon, I will quote an example of such behavior using CF_4 gas, which is known to scintillate very efficiently hard UV photons near 160nm [5]. The single-electron pulse height spectrum in CF_4 is very broad, probably because of the electron attachment during the avalanche (7-35 kV/cm at 1 bar) [7]. For example, adding TMAE to CF_4 will trigger avalanche breeding, resulting in a long tail in the single-electron pulse height spectrum [4]. This is because TMAE can be easily photo-ionized by the 160nm photons. To stop the secondary effects in this case, one needs to add 20-30% of iC_4H_{10} . Aging in $\text{CF}_4 + \text{TMAE}$ gas with a strong Fe^{55} source in a small diameter tube chamber can also reveal another interesting effect: the current steadily increases as a function of the charge dose as the photosensitive film builds up on the cathode surface. To return to a “normal aging behavior,” where the current decays away, one needs to add ~20% of iC_4H_{10} . However, the photosensitive film remains on the cathode and the chamber will remain photosensitive even if TMAE is removed [4].

The Malter effect, which is the most devastating of all secondary electron emission effects, needs three conditions to be established: (a) an insulator on the cathode, (b) the rate of ion buildup must be higher than its removal from the insulating layer, and (c) some ignition mechanism.

Examples how to establish the insulating layer are (a) avalanche producing polymers, (b) glue on electrodes, (c) gas pollutants, (d) insulating deposits left from sparks, (e) corona on a sharp point of the cathode, (f) allowing the Malter currents to go on undetected even for a few minutes, (g) poor plating, (h) resistive oxides, (i) photosensitive molecules such as TMAE, TEA, etc., (j) poorly conducting “conducting epoxies,” (k) poorly conducting carbon composite materials, (l) etching a conducting layer away from the cathode, (m) finger prints, etc.

Examples of the ignition mechanisms are (a) highly ionizing heavy ions or slow protons, (b) X-rays, (c) sparks, (d) sharp points on electrodes causing corona, (e) thin anode wires help the ignition, (f) background muons aligned with the TPC electric field direction, (g) running out of gas, etc.

By the 1986 LBL Workshop [1], many of us believed that the Malter current jumps immediately to rather high magnitude (ten to hundreds of nanoamperes). However, Ref. 8 showed that it could occur as a train of single electrons by providing first images of the Malter effect ever observed using the CRID RICH detector, which had an excellent 3-D single electron imaging capability [8]. Large currents, which would trip the HV power supply never occurred (trip level was set to 300nA). The single electron pulses came in bursts every 10-15 minutes, and in the location of UV fibers, which were used for calibration. Such a long time constant would be consistent with a very high cathode film resistance of $\rho_v \sim 2 \times 10^{15} \Omega \cdot \text{cm}$. Such a high value rarely occurs, and it may probably happen only in a very tight gas system with a very low humidity, and with a vacuum distilled TMAE, which aims to remove water from TMAE. In addition, because of charge exchange, TMAE ions are delivering a charge to cathode, and thus provide a fresh deposition of an insulating film. One should mention that prior to the very first appearance of the Malter effect, the UV fibers were producing a continuous photoelectron rate of $\sim 10 \text{ Hz/cm}$ of wire length for ~ 2 years. This was apparently enough to create an insulating film on the cathode in locations corresponding to the fiber positions only. The Malter effect was observed both on the high voltage cathode ($\sim 1.2 \text{ m}$ away), and the detector cathode (a few mm away). Fortunately, because of a vigilance, the problem was diagnosed early and could be corrected simply by reducing the UV fiber rate by a factor of ~ 2000 . In this case, reducing the supply of charge would be enough to stop it. The SLC accelerator never produced large enough background densities to ignite the effect during the physics running (perhaps, we would not be so lucky near a hadron accelerator). However, we did observe the Malter effect on one detector during the gating operation in early period (the gating wires serve as cathode when the gating pulse is on, which prevents ions to drift into TPC volume), creating a standing current of 5-10 nA even after the beam went off. Based on that experience, we decided to switch off the gating circuit during the entire SLD operation (it turns out that we did not needed). The most important lesson learned in this example is that the Malter current can consist of single electron pulses, it is localized, it can go easily undetected if the detector does not have a single electron detection sensitivity. It is very important to catch it early before thick cathode deposits develop and consequently larger persistent currents are triggered causing a real damage to electrode structure.

Subsequent laboratory tests revealed that it is indeed very easy to ignite the Malter effect in any chamber, that either has been or is exposed to TMAE [8], and it works equally well if one uses a high intensity UV Mercury lamp, or a Fe^{55} source. However, when similar tests were done with a

CsI-based MWPC photodetector, it was not possible to ignite the Malter current.¹ A possible explanation may lie in the fact that the test was done on a detector exposed to air for ~10 minutes. A typical volume resistance of the CsI layer is $\rho_v \sim 10^7 \Omega \cdot \text{cm}$, if exposed to air for ~10 minutes, which is usually the case (just after evaporation, is $\rho_v \sim 10^{10} \Omega \cdot \text{cm}$) [9]. It is believed that the volume resistance of TMAE prepared with a vacuum distillation method is much higher by at least 5 orders of magnitude. If true, it would mean that superbly prepared CsI photocathode with no contact to air may be closer to the Malter effect ignition than one exposed to air for a few minutes. One should add, however, that given a good ignition source, such as provided by HERA-B, for example, one could excite the Malter effect even in the CsI-based detectors [10].

In two following examples we show that certain materials are not conducting enough on a microscopic scale even though a simple-minded DVM test would pass. HERA-B experience with a polycarbonate foil doped with graphite (Pokalon-C) showed that it is not conducting enough from point of view of the Malter effect [11]. A chamber made of this material died in a few hours of operation at HERA-B, despite having survived long-term tests in X-ray setup. A likely explanation is that the real hadron beam produced very localized charge deposits such as ions or slow protons, which were not present in the X-ray beam. In this case, the problem was solved by coating the foil with ~90nm thick Cu/Au layer. Similarly, author's experience with a Fe^{55} source-doped silver conducting paint applied on the jet chamber potential wires was equally negative [12]. This paint was applied to study the pulse propagation along the long wires. In a week, the Malter effect was observed. White deposits were observed on many neighboring potential wires in a perpendicular direction to wires. After careful cleaning of the deposits, the chamber was operated again. However, the Malter effect returned shortly. This experience points to a danger of propagation of the problem from one wire to next. Therefore it is important to segment the wire structure so one can switch off a given segment if necessary.

The next example shows the Malter effect caused by simply running out of gas in straw chambers. The gas was CF_4 -based mixture. The trip setting was rather high (~10 μA), and after several hours of allowing large currents, the inner copper conductor was gone, all etched away [13].

It is clear from the above examples that there is a relationship between a chance to trigger the Malter effect and the cathode film resistance. Let's consider an insulating film on cathode with resistance ρ_v , relative dielectric constant ϵ_r . Let's also consider the time domain only (neglect gain and spot along the wire variation). The time constant describing the neutralization of the positive charge is $RC \sim \epsilon_r \epsilon_0 \rho_v$. Let's assume that the charge is deposited in one spot with a meantime period of T, i.e., with a rate of $r = 1/T$. To prevent the charge build up, one needs: $RC < 0.1 T$.

¹ During author's visit of A. Breskin group, Weizmann Institute, Israel.

Therefore, the maximum rate is: $r_{\max} \sim 1/(10 RC) = 1/(10 \epsilon_r \epsilon_0 \rho_v)$. For $\epsilon_r \sim 4$, $\epsilon_0 = 8.87 \text{ pF/m}$, $\rho_v \sim 2.8 \times 10^7 \text{ } \Omega \cdot \text{cm}$: $r_{\max} \sim 10 \text{ kHz}$, and for $\rho_v \sim 2.8 \times 10^{12} \text{ } \Omega \cdot \text{cm}$: $r_{\max} \sim 0.1 \text{ Hz}$.

One may conclude this section by listing suggestions on how to prevent, or at least detect, the Malter effect:

- Run at the lowest gas gain possible ($< 2 \times 10^4$).
- Pay keen attention to single electron signal activities.
- Monitor currents to a nA sensitivity.
- Segment HV as much as possible to have a chance to observe the effect in measured current.
- Have the HV trip setting as low as possible.
- Shut off voltages of the gas flow stops.
- Develop “clever” software, which can:
 - a) look for the single electron activity on a single wire,
 - b) look for any remnant activity in the chamber, when the beam is switched off,
 - c) switch off the HV power supply automatically, if a sign of persistent current occurs.
- Vigilance.
- In chapter 2.5 we will mention a possibility to cure the Malter effect with additives.
- In chapters 2.6 and 2.7 we will discuss other effects, which can alter the resistance of the electrodes.

2.3. Molecular Dissociation

The formation of molecular fragments is a necessary precursor for polymerization. Molecular fragments are formed by (a) electron or photon impact, or (b) by heat [14]. Electrons and photons in a typical avalanche have large enough energy to break the typical molecular bonds. Generally, $E_{\text{Thermal dissociation}} < E_{\text{Electron impact}} < E_{\text{Ionization energy}}$, as detailed in Table 1. The avalanche is probably too short to create thermal dissociation, except, possibly, during the Malter effect, which is a very repetitive process.

Ideal goal would be to utilize the charge exchange mechanism to send only ions of such molecules towards the cathode, which do not polymerize easily. Based on the ionization energies listed in Table 1, one can conclude that (remember that the charge is carried by molecules with the lowest ionization energy in a given gas mix):

- a) Water is less capable of performing the charge exchange when compared to DME or alcohol.
- b) TMAE mixed with any gas will always deliver charge to a cathode and thus be subject to possible damage during the ion recombination process, which can produce hard photons (note that TMAE molecule can easily polymerize).
- c) Water will deliver the charge to the cathode when mixed with Ar /CO₂ gas mix (note that water does not polymerize).

Table 1: Dissociation & ionization energies [14].

ATOM	Thermal Dissociation	Dissociation by electron impact	Ionization Energy
Ar	-	-	15.8 eV
Xe	-	-	12.1
H2	4.5 eV	8.8 eV	15.43
O2	5.1	8	12.06
H2O	4.83		12.6
CO2	7.8		13.77
CH4	4.3	4.5	12.6
CF4	5.35	5.2	
C2H6	3.6		11.5
Iso-C4H10	3.2	7	10.57
Methylal	3.2		10.0
Ethanol	3.2		10.49
Iso-propanol	3.2		10.15
DME	3.2		9.98
TMAE	2.7		5.6

2.4. Polymerization of Molecules

The polymerization of hydrocarbon molecules is often preceded by production of, for example, $\text{CH}_2\cdot$ radical, which is a typical precursor [15] for production of the polyethylene, an excellent insulator. The $\text{CH}_2\cdot$ radical has a large dipole moment and will stick preferentially to electrode surfaces. The $\text{CH}_2\cdot$ can be produced, for example, in the reaction $e^- + \text{CH}_4 \rightarrow \text{CH}_2\cdot + \text{H}_2 + e^-$. Gases, such as a mixture of argon and CO_2 , will not produce similar reaction unless there is hydrocarbon contamination. Therefore, there is indeed some logic to avoid hydrocarbons in high rate applications (above $\sim 0.5\text{-}1\text{C/cm}$).

2.5. Prevention of the Polymerization

In some cases there are some additives preventing polymerization. For example, adding the following additives in the plasma chemistry processes tend to eliminate the $\text{CH}_2\cdot$ radical by forming stable, volatile products, which impedes the polymerization process [15]: $\text{CH}_2\cdot + \text{H}_2 \rightarrow \text{CH}_4$, $2\text{CH}_2\cdot + \text{N}_2 \rightarrow 2\text{HCN} + \text{H}_2$, $\text{CH}_2\cdot + \text{O}_2 \rightarrow \text{CO}_2 + \text{H}_2$, $\text{CH}_2\cdot + \text{O}_2 \rightarrow \text{CO} + \text{H}_2\text{O}$, $\text{CH}_2\cdot + \text{H}_2\text{O} \rightarrow$

$\text{CO} + 2\text{H}_2$, $\text{CH}_2 : + \text{CO}_2 \rightarrow 2\text{CO} + \text{H}_2$, $\text{CH}_2 : + \text{CF}_4 \rightarrow \text{C}_2\text{H}_2\text{F}_4$. More generally, atomic oxygen reacts with hydrocarbon radicals and the end-product of this reaction are volatile molecules such as CO, CO₂, H₂O and H₂, which are more stable, and can be removed by a sufficient gas flow. Furthermore, organic compounds with oxygen containing groups –COOH, –CO–, –OCO–, –OH, –O–, –C=O are generally reluctant to form polymers in the plasma environment [16]. Examples of such molecules are shown in Table 2.

Table 2: Examples of usual additives to prevent polymerization [14].

Additive	Chemical formula	Dipole Moment
Water	H-O-H	1.85 D
Alcohols:	R-O-H	~1.7 D
a) Methanol	$\text{R} \equiv \text{CH}_3$	1.70 D
b) Ehanol	$\text{R} \equiv \text{CH}_3\text{CH}_2$	1.69 D
c) Iso-propanol	$\text{R} \equiv (\text{CH}_3)_2\text{CH}$	1.66 D
Methylal:	R-O-R'-O-R $\text{R} \equiv \text{CH}_3$, $\text{R}' \equiv \text{CH}_2$	
Ethers	R-O-R' DME: $\text{R} \equiv \text{R}' \equiv \text{CH}_3$	1.30 D

The above mentioned additives help to prevent the polymerization through the following processes:

- high electronegativity of oxygen.
- molecular charge exchange (avalanche-produced positive ions, which would produce higher energy photons during the recombination process, are exchanged with ions, which have lower ionization potential and does contain oxygen in its molecule. For example, if one can charge exchange into an ion of water, there is a benefit since water does not polymerize),
- molecular dipole moment (therefore they stick to anode or cathode surfaces, and therefore, the oxygen-based molecule tends to help right where it is important),
- oxygen has the freedom to make double bonds, which are stronger and allow to make more stable volatile molecules, which can be removed by gas flow (CO, CO₂, etc.),
- etching of the deposits (this effect competes with the deposition rate [17]).

Since water and alcohol are typical additives, we would like to present specific arguments why we think they are helpful. First, let's discuss water: (a) water prevents the start of polymerization, when introduced at the beginning through the reaction: $\text{CH}_2 : + \text{H}_2\text{O} \rightarrow \text{CO} + 2\text{H}_2$. (b) If water is introduced after the deposits are formed, it tends to stabilize the operation and prevent the Malter effect. (c) A water molecule may perform the charge exchange with some avalanche hydrocarbon ions, which will tend to avoid their polymerization during the charge recombination at the cathode. (d) Water by itself does not polymerize. (e) Water will help to increase the conductivity of the

insulator. (f) Its large dipole moment cools electrons with less than ~ 1 eV (it is actually the best “cool” gas available, if we would manage to prevent a condensation). Good examples of detectors where water works well are the SLD drift chamber (25%Ar+71%CO₂+4%C₄H₁₀+3000ppm H₂O), and the BaBar drift chamber (80%He+20%C₄H₁₀+3500ppm H₂O), where $\sim 85\%$ of the gas recirculates through a O₂ palladium getter. However, water additives are best suited to metal-only-designs, such as the classical large wire chambers. In applications involving dielectrics operating at high electric surface gradients, such as the anode wire supports or GEM amplifying structure, large amounts of water may cause surface breakdowns [18]. It can also cause a problematic chemistry in the CsI and TMAE-based, the RPC detectors, or CF₄-filled chambers (see chapter 2.7).

Second, let's discuss alcohol: (a) Alcohol molecules have large dipole moments, and therefore, they will be attached directly on the electrodes. (b) Alcohol molecules will perform the charge exchange more readily than water. (c) If alcohol is introduced once the deposits are formed, it tends to stabilize the operation and prevents the Malter effect [19]. (d) Alcohol molecule absorbs UV photons. (e) However, alcohol can be broken, at least in principle, to formaldehyde CH₂ = O, which can polymerize. However, the rate of this polymerization is slower compared to the rate of the ordinary hydrocarbons, and therefore, the addition of alcohol can be considered as beneficial. (f) Various dissociation byproducts, such as CH₂O₂, C₂H₄O or C₂H₄O₂ can react with aluminum and nickel and create oxides that are highly resistant [20]. (g) Last, but not least, alcohol is a solvent and can cause swelling and expansions of some plastic material, such as Mylar or Kapton, which may be important for straw tubes.

A. Boyarski showed that the Malter deposits in a form of whiskers could actually be removed by adding 200-1000ppm of oxygen to 80%He+20%*i*C₄H₁₀ gas and allowing large current [19]. It appears that the damaged chamber could be cured by this method. However, one should point out that the curing was done on artificially created whiskers, which have very high gradient; one has to repeat it with an oil film deposited on a cathode wire. If proven, this would be the first result in our field, which supports the tests previously reported by plasma chemists, and also by astronomers who clean the mirrors in the oxygen plasma [21].

Unfortunately, the oxygen additive is not going to help with the Si deposits, because the equivalent molecule to CO₂ is SiO₂, which is not volatile. One way to remove the Si deposits is to operate with the CF₄ gas, and form gaseous SiF₄ in avalanches. However, one has to be prepared to face the fact that CF₄ introduces a very complicated chemistry, such as a possible formation of (a) HF when water or hydrocarbons are present [22], (b) resistive metal fluorides on nearby electrodes [23], (c) long-lived electronegative ions F⁻ and CF₃⁻ [24]. In addition, CF₄ is producing hard UV photons in the avalanches (~ 160 nm) [5], which may trigger the secondary electrons on nearby electrodes. A better way to deal with the Si deposits might be to remove the source of the silicone. Known sources are (a) O-rings with Si-based grease, (b) valves with Si-based grease, (c) G-10 boards, (d) molecular sieves, (e) general pollution of the system, (e) possibly copper tubing,

which may be produced with a help of Si-based grease, etc. One way to protect against the Si pollution is to use the semiconductor industry quality gas system.

Despite certain dangers involved in using CF_4 gas, a temptation to use it is strong because it is a very fast gas suitable for high rate applications at future high luminosity accelerators. According to Plasma Chemistry, CF_4 gas is as excellent etching additive equal to O_2 [14], and therefore it should help to remove possible polymerization deposits, which can be present due to a presence of hydrocarbon impurities. A nice example of this effect is work of Openshaw and his co-workers in Ref. 25. Several chambers were aged in 50%Ar+50% C_2H_6 and 50%Ar+50% C_2H_6 +0.2% Ethanol, causing a pulse height reduction of 25-30% and visible deposits on the anode wire. After switching to 80% CF_4 +20% C_4H_{10} , the pulse height and currents recovered to greater than 98% of their initial values. The authors stress that all of the recovery tests have been done with 80% CF_4 +20% C_4H_{10} gas mixture and that introducing different components or even changing the relative proportions of CF_4 and C_4H_{10} could totally change the chemical reactions. Wise, Kadyk and Hess studied the aging properties of $\text{CF}_4/\text{C}_4\text{H}_{10}$ gases and have found two regions of higher anode depositions, one in the region of low concentration of CF_4 (0-20%) and one in the region of high concentration of CF_4 (85-100%) [23]. The existence of the second region was not expected. In addition to this complexity, Kadyk reported an amazingly rapid aging rate of $\sim 123000\%/C/cm$ in 50%Ar+40% CF_4 + 10% O_2 (with a gold-plated anode wire) [3,23], a mixture expected to be strongly etching. No wire deposit could be seen under an optical microscope. In this case, one is likely dealing with resistive metal-fluoride film deposits on the cathode (see further discussion in chapter 2.7 and Ref. 23). Gold-plated wires do not age in CF_4 in this case (see chapter 2.7 for other aspects through). Because of the formation of resistive metal-fluoride films, the current drawn in accelerated aging test is not a reliable indicator of anode aging for CF_4 -rich gases. Instead, one should use the pulse height measurement and an analysis of deposits. I would like to add that understanding of these details shows difficulty of the detector aging science. Nevertheless, as I said, despite certain dangers, a gas mix 95%Ar+5% CF_4 is a current candidate for gaseous detectors, such as Micromegas, to operate at high rate [26]. Because there is no quencher of hard UV photons in this gas, one should operate at very low gas gain, which may eliminate the single electron detection capability. In addition, the electrodes should be gold plated, and the system should have low hydrocarbon contamination.

2.6. Electrolytic Processes in the Insulators

By electrolytic processes we mean that current is made of ions rather than electrons, as we are used to in metals or simple resistors. This subject was not discussed during the 1986 LBL Aging Workshop, and not much even during the DESY workshop. It is a new subject in the detector physics, and it is becoming more and more relevant mainly because of high luminosity operations,

which are being planned. With the introduction of RPC, CsI-based and micro-strip detectors, questions can be asked what role the ionic currents play in the aging effects. This is a very complicated question, because the chemistry of ionic currents in glass, Bakelite (Phenol-Formaldehyde polymer), Linseed oil and other materials is not well understood, especially from the point of view of changes in the volume resistance as a function of the accumulated charge. These materials are not simple resistors as one could naively assume. Because of a relative novelty of this type of aging, I will spend a bit more time on this topic.

(a)

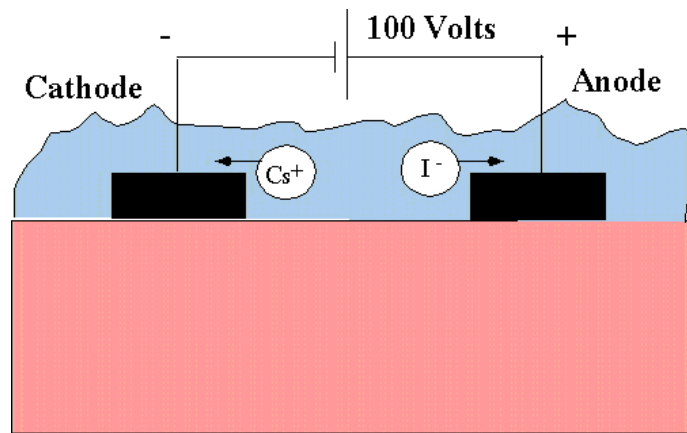

(b)

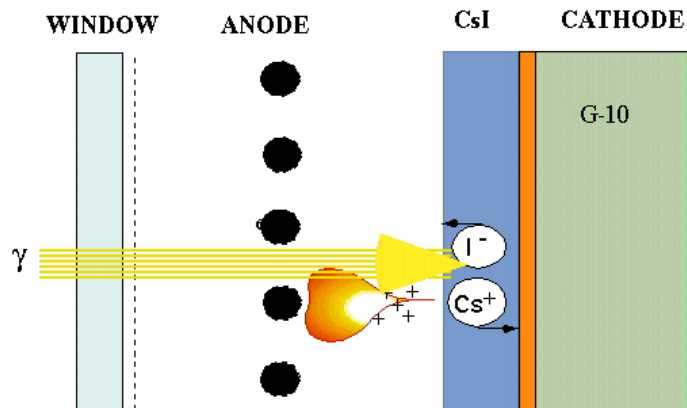

Fig.1. (a) Electrolytic current in CsI on a Micro-strip detector surface under influence of external voltage. Iodine ions move to anode, cesium ions to cathode [9]. This process will alter the resistance distribution in the CsI layer. (b) A similar electrolytic current is expected in the operating MWPC chamber under an influence of the gain and the photon flux.

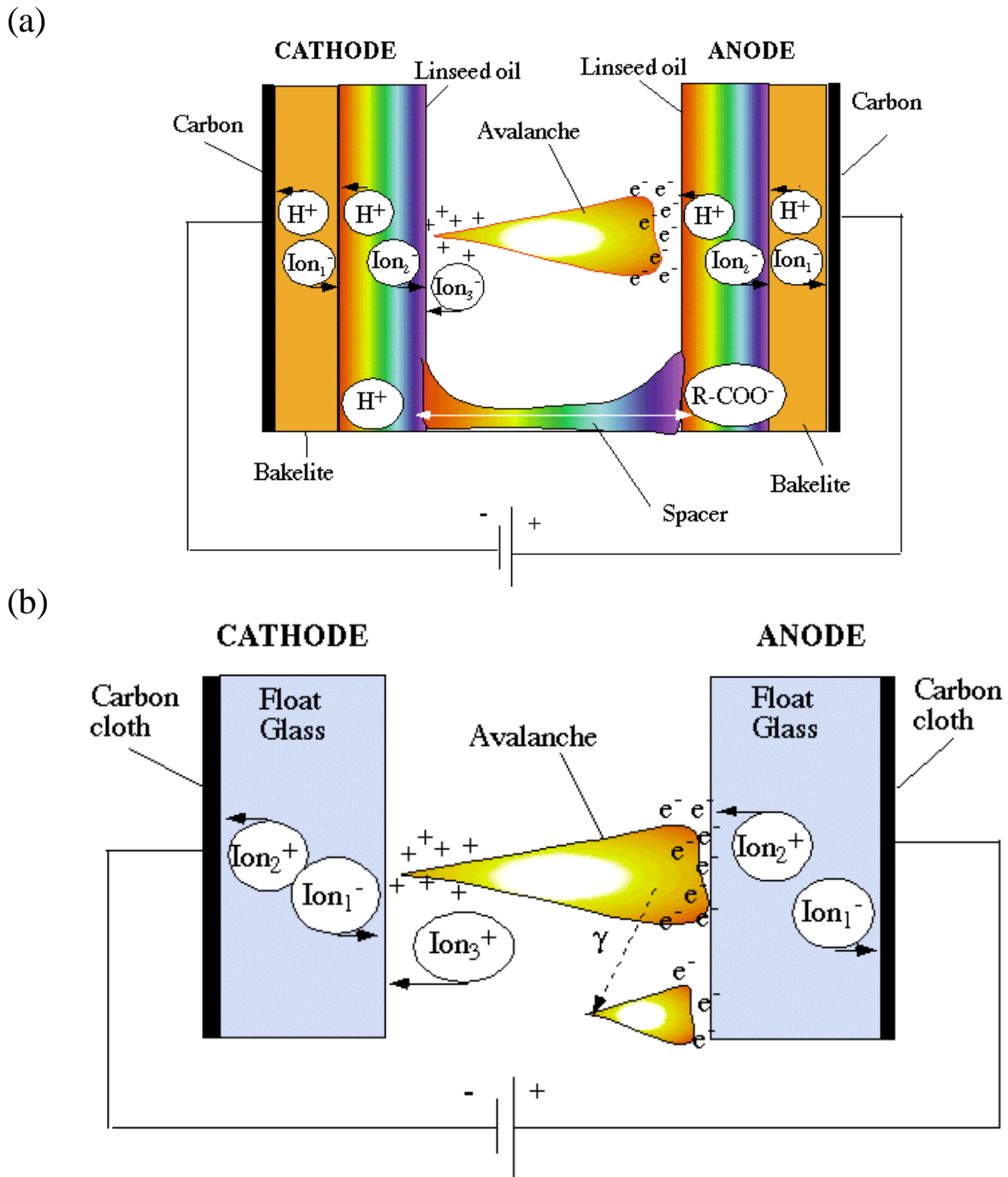
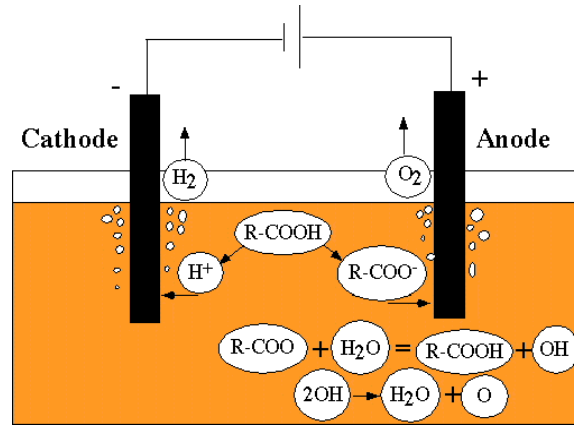
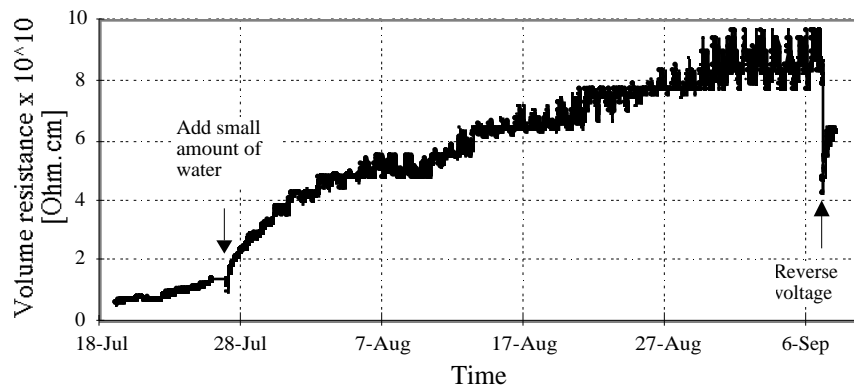

Fig. 2. (a) Ionic current in a Linseed oil-filled Bakelite RPC requires the charge exchange among three different ions of the gas, the Linseed oil and the Bakelite. (b) Although the glass-based RPC seems to be more simple from the ionic current point of view, a long term behavior of the float glass resistance is poorly understood at present.

(a)



(b)



(c)

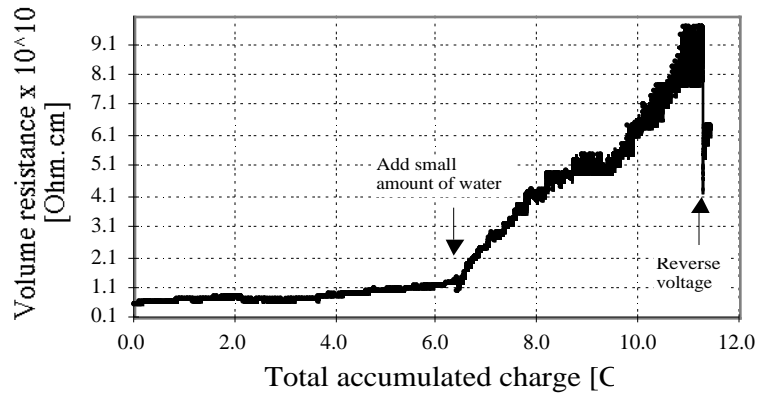

Fig. 3. (a) Proposed equivalent model of the electrolytic process in the Linseed oil [30]. (b) Volume resistance of the fresh new liquid Linseed oil as a function of time. The electrodes were $\sim 1\text{mm}$ apart and a potential between them is at 3 kV. The current is not much sensitive to a voltage reversal, however, it is very sensitive to day-to-night humidity variation and to water addition. After ~ 11 Coulombs, the viscosity of the Linseed oil became like thick honey, full of surface wrinkles. (c) The same data, now plotted as a function of accumulated charge density.

The current through evaporated layer of CsI is carried by the Cs^+ and I^- ions [9]. In fact, this phenomenon can be observed visually if one arrange a simple test according to Fig.1a. Fig. 1b shows a MWPC chamber with a CsI layer on its cathode. When exposed to a gain and a high photon flux, a photocurrent through the CsI layer brings iodine ions to the cathode surface and the cesium ions in contact with the pad electrodes, where they might react chemically. The iodine on the surface alters its quantum efficiency and the resistance, because it is very resistive ($\rho \sim 1.3 \times 10^9 \Omega \cdot \text{cm}$). On the other hand, Cesium is very conductive $\rho \sim 2 \times 10^{-5} \Omega \cdot \text{cm}$. As we mentioned above, a typical volume resistance of the CsI layer is $\rho \sim 10^7 \Omega \cdot \text{cm}$, if exposed to air for ~ 10 minutes, which is usually the case (just after evaporation, it is $\rho \sim 10^{10} \Omega \cdot \text{cm}$) [9]. The iodine migration to the top of the surface is a possible mechanism to increase the resistance of the CsI layer, and therefore increase a chance of the Malter effect ignition.

Changes in conductivity of the ordinary glass were observed in the Micro-strip detectors, which prevented a successful operation, and forced the designers to choose a special expensive electron conducting glass for the substrate [27]. The conductivity of the standard glass is due to the movement of the alkaline ions. However, during the long-term operation, the alkali ions, such as sodium, migrate towards the cathode by a force of the electric field and leave a depleted layer close to anode. This leads to a permanent increase of the surface resistance. The ionic glasses therefore suffer from long-term instability. It is therefore expected that the Belle RPCs will suffer from the same phenomenon, although at this point they did not reach this particular limit yet. To use the electron conducting glasses on such a large scale, as the typical RPC size requires is out of question. It is interesting to point out that the BaBar/DIRC photomultiplier glass started to corrode in the presence of ultra-pure water [28]. Such water, hungry for ions, acted as a “vacuum pump” removing the sodium from the glass, which resulted in subsequent glass corrosion. Luckily for the DIRC group, the corrosion rates are slow and the detector is expected to operate for up to ten years.

The BaBar RPCs are using Bakelite electrodes covered with the Linseed oil. Again, the current is due to ionic motion, which may be even more complicated than in the glass, because both the Linseed oil and the Bakelite are more complex substances. Ionic current in such RPC requires a delicate charge exchange among different ions of the gas, the Linseed oil and the Bakelite - see Fig.2a. A model of the Belle glass-based RPC ionic current is shown on Fig.2b. The Linseed oil, made from pressed seeds, is a very complex organic compound [29]. We will simplify the complexity involved by proposing the following simple model – see Fig. 3a. One could safely assume that the initial “cocktail of molecules” also contains water. The water can also get into the Linseed oil layer either from the gas or from the Bakelite, which is known to have affinity to water. Pure water does not conduct; however, when mixed with acid, it does conduct very well through

(a)

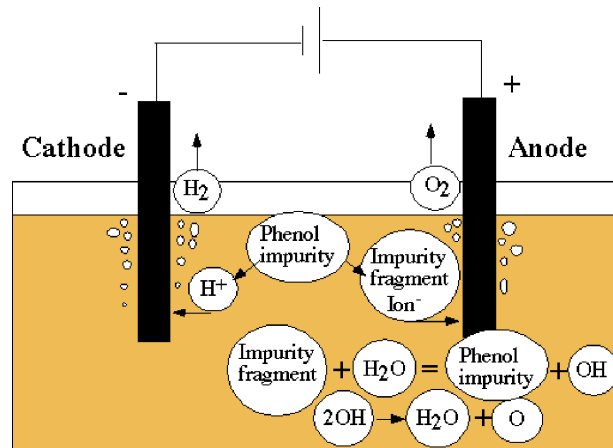

(b)

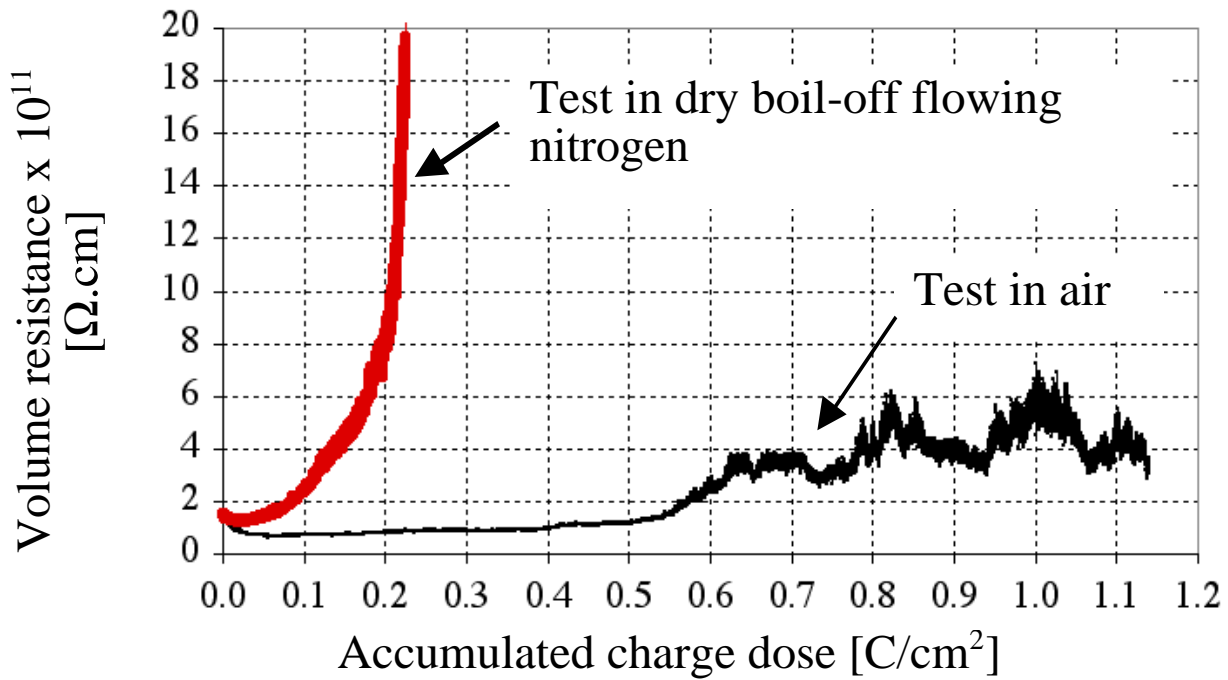

Fig. 4. (a) Proposed equivalent model of the electrolytic process in the Bakelite [30]. (b) Volume resistance of the Bakelite sheet as a function of accumulated charge density. In one case the Bakelite sheet was in air and subject to humidity variation, and in the second case a different sheet was placed in dry flowing boil-off nitrogen. Clearly, the resistance is increasing very rapidly in the second case. The initial drop below $\sim 0.03\text{C}/\text{cm}^2$ is due to settling of the weight changing the contact.

the ionic carriers. A molecule, which may facilitate current conductivity in the “uncured” Linseed oil, is the fatty acid R-COOH — an organic acid molecule. A possible sequence is as follows: (a)

R-COOH + potential \rightarrow H⁺ = R-COO⁻; (b) R-COO⁻ ion delivers the charge to anode and R-COO returns to the fluid; (c) H⁺ ion delivers the charge to the cathode, where it forms an H₂ molecule and escapes; (d) R-COO + H₂O \rightarrow R-COOH + OH, which returns the fatty acid back into the cycle; (e) 2OH \rightarrow H₂O + 2O, and 2O \rightarrow O₂, which delivers oxygen near the anode. The important point is that water modulates conductivity. If we remove water, R-COO⁻ will only deliver the charge, R-COO will just plate on anode, but it will not return R-COOH back into the current forming cycle, i.e., the current will slowly stop. Adding water back should restart the conduction. In fact, this was exactly what was observed in a simple bench-top electrolytic experiment that was conducted by the author [30]. Figures 3b and 3c show author's measurement of the volume resistance increase of the fresh liquid Linseed oil. One should also point out that the liquid had some bubbles at the end, indicating a trapped gas, and after ~10 Coulombs the liquid turned to a thick honey-like substance.

One can propose a similar electrolytic model for the Bakelite conductivity – see Fig. 4a. Figure 4b show author's measurement showing that the Bakelite volume resistance increased by a factor of five after ~0.7C/cm², if the Bakelite sheet is in air; however, the same resistance increase occurred after only ~0.15C/cm², if it is in dry flowing boil-off nitrogen at room temperature. This again confirms that water modulates the resistance value of the Bakelite, and makes it consistent with the electrolytic model. The dependency in air appears to be complicated and perhaps even nonlinear with an appearance of a threshold behavior. In principle, it is possible to have a threshold in the resistance increase, if ions, responsible for the conductivity, are all used up. In fact, if several types of ions are involved, one could have several thresholds. A value between ~0.15 and ~0.7C/cm² is a very high accumulated charge density, which will be relevant only at very high rate applications, or localized breakdowns. In addition, there is a dependency on temperature. For example, one week at 40°C in air increases the Bakelite volume resistance by a factor of ~3 [30]. Combining all these effects may increase the Bakelite resistance significantly. For example, if it would increase by a factor of 50-100, it would start affecting the efficiency due to the voltage division effect, and one may also drive the RPC into a Malter effect.

However, in addition to the above general comments, the BaBar RPCs have an additional very significant problem. It is related to a poor drainage of the Linseed oil during the chamber construction, which resulted in “over-oiling” of some areas [31]. High voltage operation in C₂H₂F₄ gas while allowing large currents at elevated temperature resulted in a chemical reaction resulting in a very low resistance of such modified Linseed oil ($\rho_v \sim 2 \times 10^8 \Omega \cdot \text{cm}$ compared to a nominal value of the fresh Linseed oil: $\rho_v \sim 8 \times 10^9 \Omega \cdot \text{cm}$). Each button covered with such modified oil represents effectively a short [30], which affects the efficiency nearby, especially if the Bakelite electrodes are also covered by a thick Linseed oil film. Marcello Picollo discovered that running high currents in the damaged RPCs filled with Argon gas allows a partial or full recovery of the

efficiency in these regions [32]. Subsequent author's tests showed that the resistance of the extracted Linseed oil-covered buttons from the bad RPC regions can be increased substantially (a factor of >100) by allowing a large current through with a total charge of ~0.5-1.5 C/button, independent of polarity of current [30]. If this will be proven on a large scale, one can probably cure a good portion of bad BaBar RPCs.

2.7. Chemistry of Gases and Nearby Electrodes

I will choose three examples. The first example shows a rapid aging in CF_4 gas after a charge dose of a few mC/cm [23]. These results were obtained with a 99.999% pure CF_4 gas, with or without Nanochem filter. Addition of 20% of iC_4H_{10} stopped the rapid aging rate. This effect was explained by a formation of the resistive metal-fluoride film on the non-gold plated surfaces near avalanche (either anode or cathode, or both). The formation of such resistive layer on the cathode may be then easily trigger the subsequent Malter effect, although, the resistance of such film is presently not known. It may be important to gold-plate electrode surfaces of the MICROMEGAS or GEM detectors, if CF_4 gas is considered.

The second example is from the Belle experiment at KEK, Japan. Their RPC detector electrodes are made of ordinary float glass. After a successful start at full efficiency, the RPCs started to deteriorate rapidly. A massive R&D effort was initiated, which resulted in formulating the following model [33]. Freon gas ($\text{C}_2\text{H}_2\text{F}_4$) together with water, in the presence of plasma formed HF acid which etched the glass surface. This in turn increased the current and the detection efficiency drop. It was found that initially the chambers operated with a large volume of water in gas (~2000 ppm). The water permeated through the Polyflow gas tubing. The solution to suppress the formation of HF was to reduce water fraction from 2000ppm to <10ppm, by installing copper tubing (it may still form using hydrogen from the hydrocarbon, but this rate seems to be acceptable).

The third example is a swelling of anode [34], observed in straw tube tests operating with 70%Xe+10%CO₂+20%CF₄. A wire diameter increased by 20% after an accumulated charge of ~9 C/cm. A very complex chemistry model, involving reaction products of tungsten, oxygen and fluorine, was proposed to explain the phenomenon. Water may have played also a part to form HF molecule.

2.8. Gas system consideration

I will chose only one example. The measurement by Kothaus showing that even a temporary replacement of stainless steel tubing with a PVC tubing triggers a high rate of aging, and that the deterioration continues even when the original stainless steel tubing is restored [35]. It is interesting to point out the PVC tubing contains molecular chains involving CH_2 molecular fragment [2]. The measurement of Kothaus is now accepted as a classical example showing the

importance to choose a high quality gas tubing. Yet, it appears that people continue to select “smelly” valves and low-quality plumbing materials (for example, a copper, tubing which was not even cleaned in hydrogen oven). Similarly, Si-based molecular sieves without adequate mechanical filters preventing Si to get into the active areas of the detector, detectors full of G-10, etc. The usual argument of the management is the cost of the gas system, of course. However, usually, the cost of a possible detector replacement is not included in such discussions. The semiconductor industry did not learn about their plumbing specification by accident. It is an expensive endeavor even for them; however, alternatives are even more expensive. This point was already argued at the 1986 LBL aging workshop.

2.9. Micro-pattern detectors

There are two major sources of degradation of the Microstrip detectors: substrate charging and deposition of polymers. It has been demonstrated [36] that the polymerization can be avoided up to at least ~ 120 mC/cm of collected charge, which is equivalent to ten years of operation at LHC. Authors also show that one should avoid using Borosilicate glass to prevent long-term modification of gain due to charging caused by the sodium migration. Use of electron-conducting glass solves the problem (see also Ref. 27).

Based on tests with the 8.9 keV X-rays for the Compass experiment, the GEM detectors are doing well, i.e., no loss of energy resolution or gain was reported up to a charge dose of ~ 7 mC/mm² [37].

Tests with MICROMEGAS detector are also in progress. So far, no gain loss was reported up to a charge dose of 2-3 mC/mm² with Ar+5%CF₄ or Ne+10%C₂H₆+11%CF₄ gases [26].

Conclusions

The most devastating of all aging effects are the secondary electron emission processes, such as the Malter effect. These effects can be very localized, and can proceed undetected because the small currents are involved, at least in the early stages before a thick film develops on the cathode. The detection of such processes is difficult because the single electron sensitivity is required, often in a presence of large background. Clever software approaches may be needed to catch such effects early enough before they do damage. More frequent use of oscilloscopes would help. To clean the insulating deposits periodically either in oxygen or CF₄ plasma needs more studies to dare to apply it in large systems.

Although the CF₄-based gases are promising from several point of views, they may have complicated chemistry resulting in a possible severe electrode corrosion. Before any large experiment decides to use such gas we recommend extensive long-term testing. For example, such gases cannot use water additive or be mixed with hydrocarbon molecules because of a formation of HF, and all electrodes should be gold-plated to prevent a formation of resistive metal fluorides.

Detectors operating at high luminosity, which use insulators, may face a new domain of aging: changes in resistance of the electrodes and supporting structure due to ionic currents. This subject is relatively new and not yet fully understood in case of the RPC detectors, although it is already recognized in the Microstrip detectors.

It is important to worry about material choice and cleanliness of the system. We do not understand a precise role of impurities and their relationship to a particular gas mix. In some cases they matter, in some other cases they do not seem to. One probably should generate a well-equipped centralized facility employing a dedicated pair of chemist and physicist, both serving the entire community, which would support it financially and intellectually. Perhaps, after 5-10 years, repeating systematically all significant aging tests reported in literature up to this point, under conditions which are better understood, one may yield some understanding. To duplicate such facility in many places would be a mistake.

The aging science is still in its infancy, if we insist on quantitative explanations. Many new things will be learned by the time the LHC finishes. The benefits from Plasma Chemistry would be greater if there are more tests with similar conditions as in our field.

REFERENCES

- [1] Proc. Workshop on Radiation Damage to Wire Chambers, LBL, Jan.1986, LBL-21170 (J. Kadyk – editor).
- [2] J. Va'vra, Nucl. Instr. & Meth., A252(1986)547.
- [3] J. Kadyk, Nucl. Instr. & Meth., A300(1991)436.
- [4] J. Va'vra, J. Kadyk, J. Wise, O. Coyle, Nucl. Instr. & Meth., A370 (1996) 352.
- [5] A. Pansky, A. Breskin, A. Buzulutskov, R. Chechik, V. Elkind, and J. Va'vra, Nucl. Instr. & Meth., A354(1995)262.
- [6] L. Malter, Phys. Rev. 50(1936).
- [7] P.G. Datskos, J.G. Carter and L.G. Chrisoprou, J. Appl. Phys. 71(1992)15.
- [8] J. Va'vra, Nucl. Instr. & Meth., A367(1995)353.
- [9] J. Va'vra, A. Breskin, A. Buzulutskov, R. Chechik, and E. Shefer, Nucl. Instr. & Meth., A387(1997)154.
- [10] P. Krizan, private communication.
- [11] Ch. Stegmann, Nucl. Instr. & Meth., A453(2000)153 and
M Hohlmann, Nucl. Instr. & Meth., A461(2001)21.
- [12] J. Va'vra, "The 8-wire prototype," OPAL R&D during author's stay at CERN, 1984, unpublished.
- [13] K. Lang, private communication.
- [14] H. Yasuda, Plasma Polymerization, Academic Press, Inc., 1985.
H. V. Boeing, Plasma Science and Technology, Cornell University Press, 1982.
A. von Engel, Ionized gases, American Institute of Physics, AIP Press, 1965.

- The Handbook of Chemistry and Physics, The Chemical Rubber Co., Cleveland, Ohio.
- [15] D. W. Hess, Proc. Workshop on Radiation Damage to Wire Chambers, LBL, Jan.1986, LBL-21170.
- [16] H. Yasuda, Plasma Polymerization, page 113, Academic Press, Inc., 1985.
- [17] H. Yasuda, Plasma Polymerization, Academic Press, Inc., 1985, and
“New Insights into Aging Phenomena from Plasma Chemistry,” DESY workshop, 2001.
- [18] S. Bachman et al., CERN-EP/2000-151, 11 December 2000.
- [19] A. Boyarski, DESY workshop, 2001
- [20] M. Atac, Proc. Workshop on Radiation Damage to Wire Chambers, LBL, Jan.1986, LBL-21170, and
IEEE Trans. Nucl. Sci. NS-34 (1) (1987)481.
- [21] R. Gillette et al., Vac. Sci. Tech., 7(1070)534.
- [22] J. Schreiner and M. Titov, DESY workshop, 2001.
- [23] J. Wise, LBL Ph.D Thesis, LBL-32500, UC-414, August 1992, and
J. Wise, J. Kadyk and D.W. Hess, J. Appl. Physics, 74(9)5327, and
J. Va’vra, P. Coyle, J. Kadyk and J. Wise, Nucl. Instr. & Meth., A324(1993)113.
- [24] M. Copeans et al., Nucl. Instr. & Meth., A337(1993)122.
- [25] R. Openshaw, R.S. Henderson, W. Faszler and M. Salomom, Nucl. Instr. & Meth., A307(1991)298.
- [26] Y. Giomataris, private communication.
- [27] G. Cicognani, P. Convert, A. Oed, J. Pannetier, "Stability of different Microstrip plates on ionic and
electronic conducting glass," Proc. of the Int. Workshop on Micro-Strip Gas Chamber, Lyon, pp. 235-
241, December 1995.
- [28] P. Bourgeois and J. Va’vra, “Corrosion of Glass Windows of DIRC PMTs,” ICFA Instrumentation
Bulletin, Vol. 22, Spring 2001, <http://www.slac.stanford.edu/pubs/icfa/spring01/paper3/paper3.pdf>.
- [29] Linseed oil contains the glycerides of linolenic, linoleic, oleic, stearic, and palmitic acids with a high-
degree of unsaturation of its fatty acid radicals.
- [30] J. Va’vra, http://www.slac.stanford.edu/~jjv/activity/babar_rpc_my_summary.pdf.
- [31] J.Va’vra, “Short Summary of a Session on New Aging Effects – RPC detectors,” DESY workshop, 2001.
- [32] M. Piccolo, private communication.
- [33] D. Marlow, Vienna Instrumentation Conference, Vienna, 2001, and invited talk at this workshop.
- [34] A. Krivchitch, Vienna Instrumentation Conference, Vienna, 2001.
- [35] D. Kothaus, Proc. Workshop on Radiation Damage to Wire Chambers, LBL, Jan.1986, LBL-21170.
- [36] R. Bouclier et al., Nucl. Instr. & Meth., A381(1996)289.
- [37] S. Kappler, DESY workshop, 2001.