



ISSN (Print) : 2320 – 3765
ISSN (Online): 2278 – 8875

International Journal of Advanced Research in Electrical, Electronics and Instrumentation Engineering

(An ISO 3297: 2007 Certified Organization)

Vol. 2, Issue 12, December 2013

Integrating Wireless Sensor Network and Internet of Things for Detecting Fire using Fuzzy Logic

A.Krishna Mohan

Professor, Department of ECE, S V College of Engineering, Tirupati, A.P, India

ABSTRACT: The recent rapid increase of global network has an enormous impact on the smart elements cooperation. These smart elements can be located anywhere and interact with the computer system. they are random kind and have to be intelligently planned in order to support, monitoring and control of real world phenomena such as fire. Hence, the Internet of Things (IoT) concept rises like new, promising pattern for future Internet development. Wireless Sensor Networks are visualizing as integral part of the Internet of Things. These huge number of IoTs are usually used in the cooperating, monitoring, and management of real world phenomena. The WSN is designed to monitor the fire, a real world interesting phenomena. The soft computing technology like fuzzy logic is incorporated in fire security sensor nodes in order to gain the manageable sensor net work, monitoring and control of the environment. For the best design of the sensor node and maximum extension of components life cycle, the selection of the best soft computing technique is useful. In this paper the aspects such as energy efficiency, coverage, cost of the system, prediction of fire and quality of services are analyzed. The fire security sensor network is integrated with IoT which supports fast critical event signaling of fire and remote access to sensor data via the Internet.

KEYWORDS: fire protection, fuzzy logic, sensor web node, wireless sensor networks, Internet of Things, temperature sensor.

I. INTRODUCTION

Fire security systems play an increasingly significant role in life safety operations because of fire threats, risks and dangers that exist today. The effective fire management safety systems are possible within the building automation infrastructure through fast delivery of sensed data, quick response, access control, fire detection and alarm and emergency communications. One of the ways to monitor and detect fire is to use the Wireless Sensor Networks (WSN) and integrating WSN with the Internet of Things (IoT). WSN are composed of spatially distributed nodes equipped with sensing devices to monitor environmental conditions at different location, processing unit, communication components (wireless transmitter/receiver), storage unit, and an energy source power unit as in Fig. 1. These tiny sensing devices have limited computation capabilities, and can collaborate in real time monitoring, sensing, and communicating to base station or computer system for providing the feature of Internet of Things.

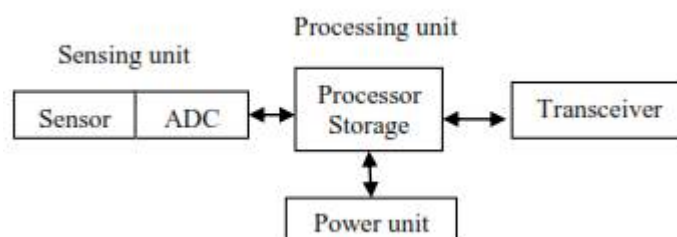

Fig.1. Architecture of a sensor node

International Journal of Advanced Research in Electrical, Electronics and Instrumentation Engineering

(An ISO 3297: 2007 Certified Organization)

Vol. 2, Issue 12, December 2013

Event detection is one of the main components in numerous WSN applications. To detect critical events like fire, one or a combination of sensors and detection algorithm is needed. The sensors are the part of a WSN. Thus, the detection of a critical event should be delivered to the user as soon as possible. The IoT will connect physical or analog environments to the digital Internet for building and home automation. In order to show how the WSN based system for continuous monitoring and/or recording critical temperature values, powered soft computing technologies and web enablement, can be designed and deployed are discussed in this paper. The rest of the paper is organized as follows. Section 2 presents the related work analysis. In Section 3 the use of fuzzy logic in WSNs for fire detection is presented. Section 4 presents the process of Sensor Web structure creation and the way of data processing and visualization along with the obtained measurement results. Section 5 provides conclusion remarks and outlines the directions for future work.

II. RELATED WORK

The Zujue Chen [1] et al. discussed about the design of wireless sensor network node for carbon monoxide monitoring. The Hakilo Sabit [2] et al. discussed about the wireless sensor network based wildfire hazard prediction system modeling. The Andrey Somov [3] et al. analyzed about the deployment and evaluation of a wireless sensor network for methane leak detection. Yeon-sup Lim et al. are analyzed [4] Fire Detection and Rescue Support Framework with Wireless Sensor Networks. Daniela Ballari et al. [5] are analyzed about a mobility constraint model to infer sensor behaviour in forest fire risk monitoring. Junguo ZHANG et al. [6] are discussed about the forest fire detection system based on a ZigBee wireless sensor network. Sudipta Bhattacharjee et al. [7] are discussed wireless sensor network-based fire detection, alarming, monitoring and prevention system for Bord-and-Pillar coal mines. The Cetin Elmas and Yusuf Sonmez [8] are analyzed the data fusion framework with novel hybrid algorithm for multi-agent decision support system for forest fire. The Gui Yang et al. [9] are analyzed about the study on remote monitoring system for landslide hazard based on Wireless Sensor Network and its application. Wei Tan et al. [10] is discussed the Mine Fire Detection System Based on Wireless Sensor Network.

III. FUZZY LOGIC USAGE IN WSN FOR FIRE DETECTION

Fuzzy logic is derived from fuzzy set theory dealing with reasoning that is approximate rather than precisely deduced from classical predicate logic. Fuzzy logic based system performs its work with the help of four steps denoted as fuzzifier, fuzzy inference machine, rule base and defuzzifier. A typical fuzzy logic system is shown in Figure 2. The fuzzy logic became a mathematical discipline for describing human reasoning with rigorous mathematical notation. It is a multi valued logic that allows the definition of intermediate values between conventional evaluations like true/false, yes/no, high/low, small/big, short/long, etc. Notions like rather long or very long, small or very small can be formulated and processed mathematically.

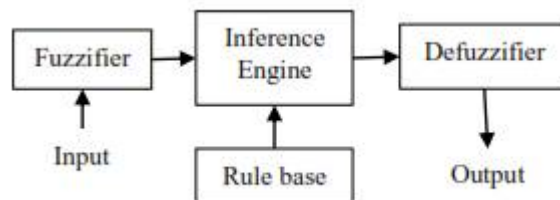

Fig.2. The structure of a fuzzy logic system

The values of Linguistic variables are words or sentences in a natural or artificial language, providing a means of systematic manipulation of vague and imprecise concepts. A MF (membership function) defines the degree of truth of input and output. MF has a value between 0 and 1. This function has different variables according to number of variables which are predefined for each individual I/O. For example, in this fire detecting system five inputs that can be taken are Temperature, Smoke, Light, Humidity, and Distance. MF for output is the probability of fire, having five variables: Very Low (VL), Very High (VH), Medium (M), High (H), Low (L). For distance, we have three variables: Close, Average, Far. The other inputs include the variables: Low (L), Medium (M), High (H). These fuzzy inputs are then fed into the inference in which the fuzzy rule base manages the inference for yielding a fuzzy output. We can define the fuzzy rule as:- If x_1 is F_1 and x_2 is F_2& x_n is F_n , then y is y_k . In the final step, the fuzzy outputs are

International Journal of Advanced Research in Electrical, Electronics and Instrumentation Engineering

(An ISO 3297: 2007 Certified Organization)

Vol. 2, Issue 12, December 2013

converted into crisp outputs & which is known as defuzzifications. The AND fuzzy operation can be used for all the rules. The minimum and the intersection between two sets are given as in equation 1, $ABCDE(x)=\min[\mu A(x),\mu B(x),\mu C(x),\mu D(x),\mu E(x)]$ ----[1]

Where, A,B,C,D,E are temperature, smoke, height, humidity and distance respectively. The evaluation result of fuzzy logic system is shown in table1.

Table 1.Evaluation results of Fuzzy Logic System

s.no	Temperatu re(°c)	Smoke (ppm)	Light (lux)	Humidity (ppm)	Distance (m)	Threat of fire (%)
1	20	30	300	80	70	27
2	80	30	300	80	70	41
3	20	80	300	80	70	34
4	20	30	900	80	70	40
5	20	30	300	100	70	19
6	20	30	300	80	50	30
7	80	80	300	80	70	50
8	80	80	800	80	70	54
9	80	80	800	40	70	63
10	100	80	800	40	20	70

IV. SENSOR WEB ARCHITECTURE

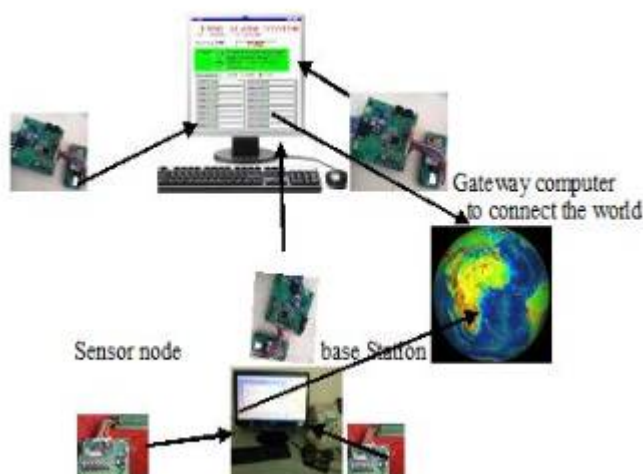

Sensor nodes in general powered by small batteries that are hard to replace or recharge. Therefore energy constraint is a major challenge for wide and remote applications. In a typical wireless enabled sensor system energy consumption occurs in three domains: Sensing, data processing and communication. During sensing the least possible of energy is consumed by the sensing circuits. In this paper fuzzy logic control mechanism is used to activate the sensing circuits (i.e., data processing and communication) only when the event of interest in the environment is available. So that WSN empowered by fuzzy logic control mechanism will work as an intelligent and power efficient sensing network. The sensed information is transmitted to the base station of short range wirelessly. The base station is communicating the information to the web based architecture as shown in fig.3.

International Journal of Advanced Research in Electrical, Electronics and Instrumentation Engineering

(An ISO 3297: 2007 Certified Organization)

Vol. 2, Issue 12, December 2013

V. RESULTS AND DISCUSSION

The sensor node as shown in fig.4 is designed with the sensors such as MQ2 sensor for smoke sensing, SHT75 sensor for temperature and humidity sensing, OPT101 sensor for light sensing. All the sensors are interfaced with the MSP 430 microcontroller with minimum interfacing components. XBeePro transceiver IC is interfaced with the microcontroller for transmitting and receiving information to and from the base station.

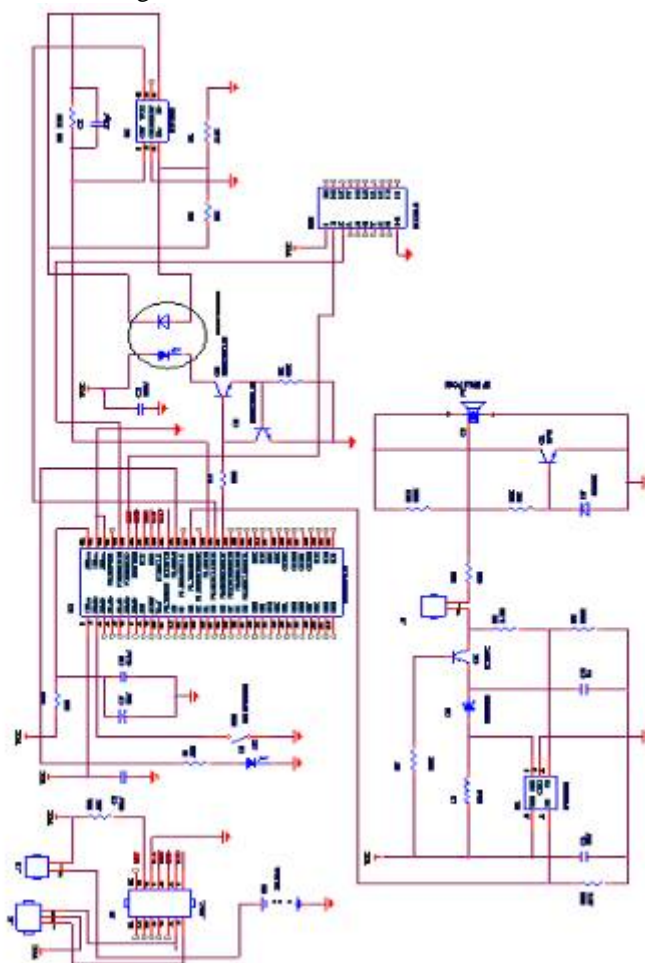

Fig.4. Design circuit of sensor node

Using team viewer software in the base station the information is shared by many users. The flowchart of base station is shown in the fig.5. With few interfacing components sensor node is designed. The cost of the system is reduced. Based on fuzzy logic the software is designed inside the node to analyze the fire risk level based on the smoke, light, temperature, humidity and distance. The fire risk level is communicated to base station by the sensor node. The base station is designed using the Visual Basic GUI software. The power consumption is achieved by activating the node after sending the authentication information and device address. Once node received its authenticated information from the base station, it send the fire risk level to base station for communication to the web architecture. After transmitting the information node will enters into sleep or power saving mode. Low power mode of microcontroller is selected. The power consumption of the node is reduced. So it can be operated for long period of time without changing the battery. The node can communicate to the base station wirelessly at a short range of 300m indoor and 1500m outdoor. If the antenna and repeater is placed the distance coverage is increased.

International Journal of Advanced Research in Electrical, Electronics and Instrumentation Engineering

(An ISO 3297: 2007 Certified Organization)

Vol. 2, Issue 12, December 2013

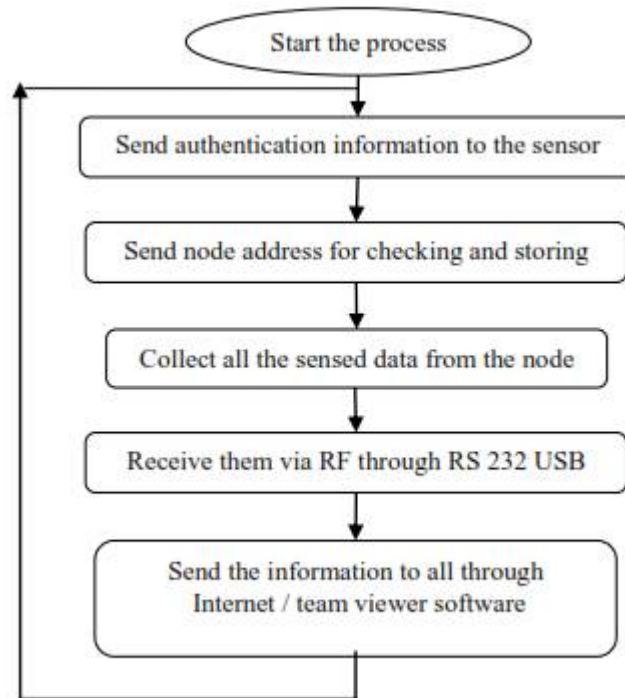

Fig.5. Flowchart of base station program

Using the fuzzy logic algorithm lux meter is used to measure the light and smoke measuring device is used to measure the smoke. The sensor node distance is calculated using the scale. The temperature and humidity value are directly measure by the sensor and displayed in the LCD module. All the sensed information is used to analyze the fire risk level as shown in the fig.6.

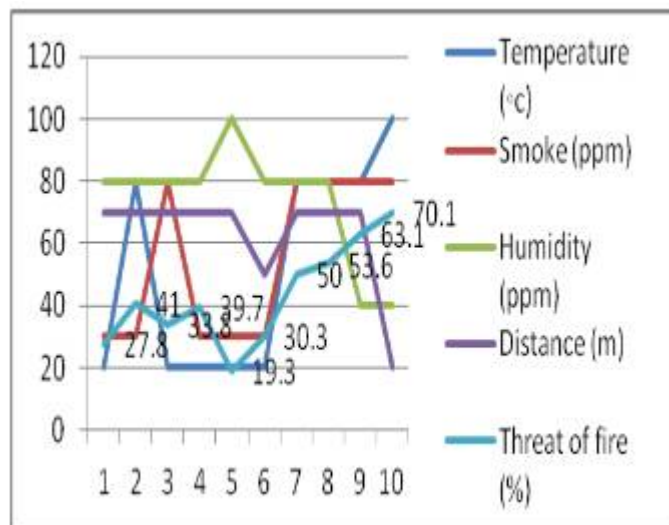

Fig.6. Analysing fire risk level using the fuzzy logic algorithm

The risk level is communicated to base station by the sensor node for further actions. From the figure, the threat of fire risk increases when temperature increases and humidity decreases. It also considers the distance between the node and

International Journal of Advanced Research in Electrical, Electronics and Instrumentation Engineering

(An ISO 3297: 2007 Certified Organization)

Vol. 2, Issue 12, December 2013

sensor. When smoke particles rise causes the rise in the threat of fire risk percentage. The base station displays the information of the sensor node as shown in fig. 7.

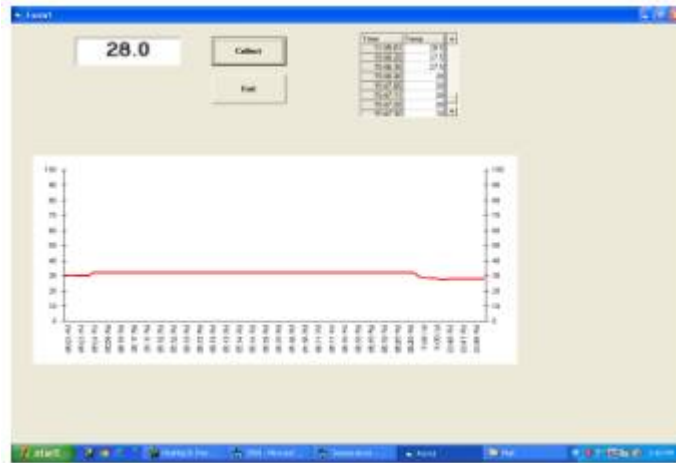

Fig.7. Sensor node output at base station

The transceiver circuit is designed to interface with the computer system or base station to activate the node and to send the authentication information. After the node gets the authentication information the information is received by the base station through the transceiver unit. The figure 8 shows the circuit diagram of the transceiver unit and figure 9 show the designed unit to interface with the computer system.

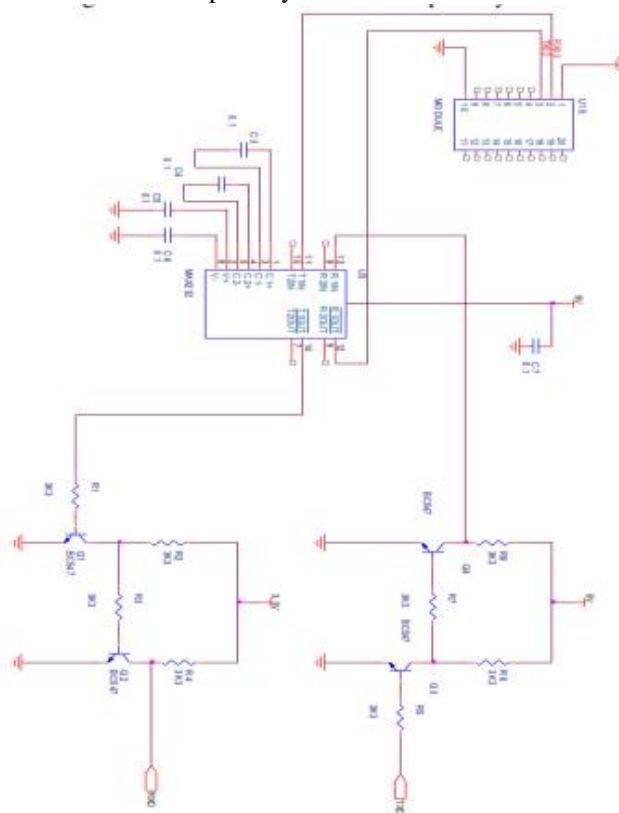

Fig.8. Transceiver Unit Design

International Journal of Advanced Research in Electrical, Electronics and Instrumentation Engineering

(An ISO 3297: 2007 Certified Organization)

Vol. 2, Issue 12, December 2013



Fig.9. Transceiver unit to interface with base station

Comparison and analyzing the work with experimental parameters:

The work has been compared with the threshold algorithm, Dempster sheffer Theory (DST) based algorithm and comparison algorithm. The following parameters are compared for the performance. They are

1. undetect fire
2. Detect unfire
3. Delay time
4. Precision in findings.

- Undetected fire: it occurs when the methods do not detect a fire event (event is not detected).
- Detect unfired: it occurs when the methods indicate a false fire presence (event is wrongly detected).
- Delay time: The difference between the time of a fire event starts and the time it is actually detected.
- Precision in finding: Precision indicates how the methods agreed to classify the condition of the environment as normal.

The performance in fuzzy logic shows excellent work [as shown in table1] in analyzing all the 4 above metrics. The comparison and threshold algorithm are simple and very poor in detecting the fire risk conditions. The Dempster Sheffer Theory based DST algorithm gives better than threshold algorithm but precision in finding is less [11]. The fuzzy logic detects fire in all conditions with all possible cases. The temperature humidity sensor only used in the threshold and DST algorithm for detecting the fire. Hence the efficiency in detecting fire locations is very less. In case of fuzzy logic the smoke sensor, light sensor, temperature and humidity sensor are used. All kind of sensors are possible to interface in the node and finds the fire in excellent way.

undetected fire and detect unfired are the major metrics. It has to be avoided. The results indicate all the algorithms are giving undetected fire and detecting unfire cases increases except the fuzzy logic. The delay of event detection in algorithms was in nanoseconds, which is an acceptable value to make reactive actions depending on the location of application. To save energy, the sensed data were sent to the PC center monitoring station every 5 seconds. After detecting fire the information is transmitted to monitoring station wirelessly using xbeepro. Fire, police and owner are informed from monitoring station through Internet at real time.

VI. CONCLUSION AND FUTURE WORK

The development of wireless sensors networks with the integration of Internet of Things arise new challenges in several fields. This system includes two aspects hardware and software. The hardware is composed of one base station with RS232& XBeePro and several sensor nodes. The sensor node and base station control module are designed. The software aspect is mainly consisted of one monitoring center/ base station that can supervise all the fire location, through the information given by all the nodes inside the whole network. The results provided can indicate the fire risk level inside the area based on fuzzy logic algorithm. This new approach gives a reliable solution that can permit to detect fires risks, in order to avoid severe damage of this disaster, when it happens. Finding the simple best algorithm is



ISSN (Print) : 2320 – 3765
ISSN (Online): 2278 – 8875

International Journal of Advanced Research in Electrical, Electronics and Instrumentation Engineering

(An ISO 3297: 2007 Certified Organization)

Vol. 2, Issue 12, December 2013

future work which suits for this architecture after analysing all possible algorithms. The fuzzy logic is compared with the threshold algorithm, comparison algorithm and Dempster sheffer theory based algorithms. Even all the remaining theory are simple and only used the temperature humidity sensor, fuzzy logic gives best performance, improved efficiency in detecting the fire risk and evaluating more sensing parameters such as smoke, light , temperature, humidity and distance. It gives best solution for finding the fire risk. The work will be extended by adding the sensors such as fire, PIR sensor and implementing algorithm like evolutionary and genetic algorithms.

REFERENCES

- [1] Zujue Chen et al., "Design of wireless sensor network node for carbon monoxide Monitoring, Telecommunication Systems", 2013, vol.53, pp.47–53.
- [2] Hakilo Sabit et al., Wireless Sensor Network Based Wildfire Hazard Prediction System Modeling, Procedia Computer Science ,2011,vol.5,pp. 106–114.
- [3] Andrey Somov et al., Deployment and evaluation of a wireless sensor network for methane leak detection, Sensors and Actuators, 2013 ,Vol.202 ,pp.217– 225.
- [4] Yeon-sup Lim et al., "A Fire Detection and Rescue Support Framework with Wireless Sensor Networks", 2007 International Conference on Convergence Information Technology, pp.135-138.
- [5] Daniela Ballari et al., "A mobility constraint model to infer sensor behaviour in forest fire risk monitoring" ,2012, the journal Computers, Environment and Urban Systems, vol.36, pp.81–95.
- [6] Junguo ZHANG et al., "Forest fire detection system based on a ZigBee wireless sensor network", 2008, Journal front for China, vol.3, pp.369–374.
- [7] Sudipta Bhattacharjee et al., " Wireless sensor network- based fire detection, alarming, monitoring and prevention system for Bord-and-Pillar coal mines", 2012, The Journal of Systems and Software , vol.85, pp. 571– 581.
- [8] Cetin Elmas and Yusuf Sonmez," Data fusion framework with novel hybrid algorithm for multi-agent Decision Support System for Forest Fire", Expert Systems with Applications, Vol. 38, 2011, pp. 9225–9236.
- [9] GUI Yang et al., "Study on remote monitoring system for landslide hazard based on Wireless Sensor Network and its application" JOURNAL OF COAL SCIENCE & ENGINEERING, Vol.17 No.4 Dec. 2011, pp 464–468.
- [10] Wei Tan et al., "Mine Fire Detection System Based on Wireless Sensor Network", Proceedings of the 2007 International Conference on Information Acquisition, 2007, Korea.
- [11] S.R. Vijayalakshmi and S.Muruganand," Real Time Monitoring of Wireless Fire Detection Node " International Conference on Emerging Trends in Engineering, Science and Technology (ICETEST - 2015) proceedings, India