

Research Article

Numerical Analysis of variation in mesh stiffness for Spur Gear Pair with Method of Phasing

D.K.Kokare^{A*} and S.S.Patil^B^AP.G.Moze, COE, Wagholi, Pune, Department of Mechanical Engineering, Maharashtra, India^BCOE, Malegaon (Bk), Pune, Department of Mechanical Engineering, Maharashtra, IndiaAccepted 13 March 2014, Available online 01 April 2014, **Special Issue-3, (April 2014)**

Abstract

Gearing assembly remains one of the major vibration sources in power transmission systems especially used in automotive, aerospace, marine and industrial applications. This study presents a novel means of reducing gear vibrations using a simple 1:1 ratio spur gear pair using a method of phasing. Variation in the gear mesh stiffness over a mesh cycle which depends on the number of pairs of teeth in contact is one of the principal causes of vibrations and instabilities and has a strong influence on the overall dynamics of the geared system. This method is based on reducing the variation in gear mesh stiffness by adding another pair of gears with phasing. Because of added phasing gear, the numbers of pairs of teeth in contacts are increased which reduces the variation in mesh stiffness. A simple spur gear model with rectangular-wave-type mesh stiffness are assumed and mesh stiffness variation is obtained numerically using MATLAB 7.5 software and is comparable in both cases i.e. normal and phasing gears. The numerical result of analysis shows the reduction in mesh stiffness variation and the possibility of reduction in vibration in simple spur gear pair using the proposed method.

Keywords: Time-varying Mesh stiffness, phasing, spur gear, vibration, MATLAB

1. Introduction

Gears are widely used basic machine element in automotive, industrial, marine and aerospace applications. Vibration reduction is a major concern in gearing applications requiring smooth and quiet operation of machinery. Many studies have reported gear dynamics to reduce vibration in spur gear pair (Ozguven, H *et al* 1988). As it is very difficult to design and manufacture gears considering the actual dynamic behaviour parameters, most of the methods for reducing gear vibration are based on static calculations. The problem of vibration with gears is studied considering three main areas: (1) macro-geometry, (2) micro-geometry and (3) surface finishing. In macro-geometry, effect of gear parameters such as number of teeth, pressure angle, contact ratio, backlash and clearance on gear vibration is studied. Micro-geometric modifications consist the tooth profile modification i.e. an intentional removal of material from the gear teeth flanks. Surface finishing as a third way of reducing gear vibrations considers teeth quality such as surface roughness, surface finishing, manufacturing tolerances, manufacturing errors as they are possible sources of dynamic excitation and their improvement can play a significant role in reducing vibrations (Giorgio, B *et al*

2008). Many studies have examined the internal excitation caused by the changing stiffness of the meshing teeth which varies periodically over a mesh cycle as the primary source of gear vibration and noise. Variation in mesh stiffness depends on the number of pairs of teeth in contact and the point of contact of the pair of teeth (Lin, J *et al* 2002, Wadkar, S *et al* 2005) and taking this into consideration, many studies have been concentrated on the modification of gear teeth (Giorgio, B *et al* 2008). But due to load dependency, such passive methods have limitations on the modifications (Townsend, D *et al* 1992). The other passive methods like the use of periodic struts for gearbox support systems, periodic drive shafts (Richards, D *et al* 2003) and one-way clutches (Cheon, *et al* 2006, 2007) are also studied for vibration reduction in spur gear pair. Active methods like use of piezoelectric actuators and magnetic bearings have also been suggested to change the operating conditions (Guan, Y *et al* 2005). However, these methods can't prevent the vibration of gears themselves as they require additional actuators, external power, signal processing etc.

Hence it is necessary to establish the method, due to which the vibration in gear pair will be minimized by gear itself without requiring any additional energy or signal processing in a manner that is independent of load conditions. Viewing this need, the method of vibration reduction in spur gear pair with phasing (i.e. phasing

*Corresponding author: D.K.Kokare

gears) is introduced in this paper.

2. Method of Phasing Gears

To control the vibrations in tooth gearings effectively, one should have an adequate knowledge of the physical nature of what causes vibrations in spur gear pair with imprecise and deformed teeth. Vibrations in gearing is caused by an internal excitations, as it occurs at the contact of two compressed elastic bodies (teeth) during their relative motion and acts on both bodies with the same intensity but in opposite directions. Because the variation of tooth mesh stiffness during meshing as a principal source of internal excitation force and vibration, modifications of the optimal tooth shape and contact ratio (CR) have been studied as ways of reducing the variation in mesh stiffness. Major variations in stiffness are caused by changes in meshing pair numbers, usually in the range 1.0-2.0 for normal spur gears. It is impossible to avoid this variation due to the integer numbers of gear teeth.

If another meshed and phased gear pair is added to reverse the stiffness functions of the two pairs, these phasing gears will complement the primary gears and reduce the mesh stiffness variation. The phasing gear pair is made up of two gears half the width and half the pitch phasing of the primary gears. The conceptual model of phasing gears is shown in Fig.1.

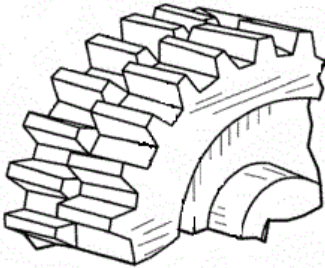

Fig.1 Conceptual model of phasing gear pair

2.1 SDOF spur gear model

Consider two identical spur gears in mesh, then, various positions of gear teeth meshing events within a mesh cycle (T_o) are determined from precise and un-deformed spur gear pair geometry as shown in Fig.2. During one complete mesh cycle, the contact starts at point A (SPC) where the addendum circle diameter of gear intersects the line of action (LOA). When pair 1 contact at point A, pair 2 is already in contact at point C which is the highest point of single tooth contact (HPSTC). As gear rotates, a point of contact moves along the line of action APD. When the pair 1 reaches the point B which is the lowest point of single tooth contact (LPSTC), pair 2 disengages at point D which the finishing point of the mesh cycle (FPC) leaving only the pair 1 in the single contact zone. When pair 1 reaches to point C, the next tooth pair engages at point A which starts another mesh cycle. Finally, when pair 1 rotates to point D, one complete tooth meshing cycle is completed. In short, AB and CD is a double pair contact zone while BC is the single pair contact zone.

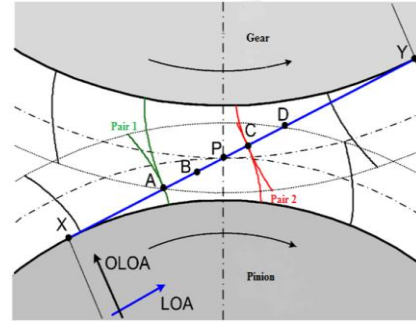

Fig.2 Various positions of gear teeth meshing events for one mesh Cycle: AB, CD= Double pair contact zone
BC= Single pair contact zone
AD= Actual length of contact

The main objective of this study is the vibration reduction and this is achieved by minimizing the excitation source due to the mesh stiffness fluctuation. For this, the system in the present study consists a SDOF non-linear model of spur gears which is available in the literature (Cheon, *et al* 2010), and is schematically represented as shown in Fig.3. Such dynamic model considers a pair of spur gears as two rigid disks coupled along the line of action through a time varying mesh stiffness $k(t)$ and a constant mesh damping c ; r_1 and r_2 are the base circle radii of the gear 1 and 2, respectively, and mass moments of inertia I_1 and I_2 ; T_i is the driving torque and T_o is the load torque.

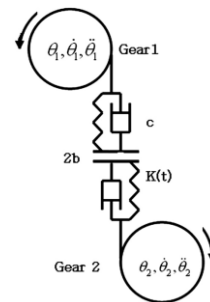

Fig.3 SDOF spur gear pair system

The total backlash is $2b$ while θ_i , θ_o , θ_1 and θ_2 represent the vibrations of the driver, load, and gears 1 and 2 about the nominal rigid body rotation, respectively.

According to the literature (Cheon, *et al* 2010), the equations of the motion of the two gears are:

$$(I_1 + I_i)\ddot{\theta}_1 + r_1c(\dot{r}_1\dot{\theta}_1 - r_2\dot{\theta}_2) + r_1k(t)\beta(t) = T_i \dots(1)$$

$$(I_2 + I_o)\ddot{\theta}_2 - r_2c(r_1\dot{\theta}_1 - r_2\dot{\theta}_2) - r_2k(t)\beta(t) = -T_o \dots(2)$$

The gear backlash non-linearity was modelled as a piecewise linear function:

$$\beta(t) = \begin{cases} r_1\theta_1 - r_2\theta_2 - b & \text{when } r_1\theta_1 - r_2\theta_2 > b \\ r_1\theta_1 - r_2\theta_2 + b & \text{when } r_1\theta_1 - r_2\theta_2 < -b \\ 0 & \text{when } |r_1\theta_1 - r_2\theta_2| \leq b \end{cases} \dots(3)$$

$s(t)$ is the distance from the contacting point to the starting point along the LOA and can be expressed as a function of

time to synchronize the time-varying stiffness with the tooth meshing phase. As the magnitude of s varies periodically with the tooth mesh frequency f_m , it can be Fourier-Transformed and is expressed as shown in (4) with $L=30$.

$$s(t) = \frac{P_b}{\pi} - \frac{P_b}{\pi} \sum_{i=1}^L \frac{1}{i} \sin(i2\pi f_m t) \dots \dots \dots (4)$$

Where f_m = Gear mesh frequency
 P_b = Transverse base pitch

2.2 Mesh period and mesh stiffness

The total mesh period T_e consists of double tooth pair contact zone (AB or CD) and single tooth pair contact zone (BC) as shown in Fig.4.

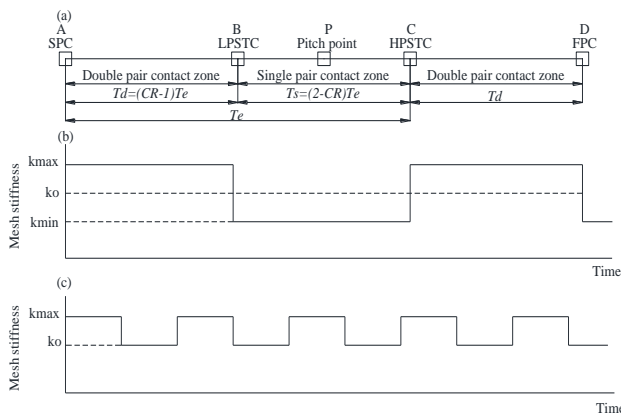

Fig.4 (a) Mesh period of a meshing spur gear pair (b) Mesh stiffness for normal spur gears (c) Mesh stiffness for phasing gears ($CR \geq 1.5$)

Mesh periods T_e , T_d and T_s are determined as:

$$T_e = \frac{60}{Nz} \dots (5)$$

$$T_d = (CR - 1)T_e \dots (6)$$

$$T_s = (2 - CR)T_e \dots (7)$$

Where N = rotational speed in rpm
 z = number of teeth
 CR = contact ratio
 T_d = mesh period for double tooth contact
 T_s = mesh period for single tooth contact
 T_e = total mesh period

3. Simulation results

Table 1 shows the parameters of an identical spur gear pair used in this study. The average mesh stiffness ($k_o = 286.3 \times 10^6 N/m$), is calculated using ISO-6336 standard

(Fernandez, A et al 2013) and is used here to evaluate mesh stiffness variation.

Table 1 Gear parameters

Parameters	Value
Type	Standard full depth, Involute
Teeth number	20
Module(mm)	1.86
Pressure angle(degrees)	20
Base radius(mm)	17.4282
Face width(mm)	15
Base pitch(mm)	5.3975
ICR	1.62
Material	Steel
Young's modulus(N/mm ²)	2*10 ⁵

Mesh stiffness Variation is numerically calculated using MATLAB 7.5 software and the results are plotted as shown in Fig.5. The time-varying mesh stiffness $k(t)$ is obtained as (Kahraman, A et al 1999):

$$k(t) = k_o + \sum_{r=1}^R k_r \cos(2\pi f_m t - \phi_r) \dots \dots \dots (8)$$

The values of k_r and ϕ_r are obtained using following formulae:

$$\frac{k_o}{k_s} = ICR \dots \dots \dots (9)$$

$$\frac{k_r}{k_s} = \frac{\sqrt{2 - 2 \cos[2\pi(ICR - 1)]}}{\pi} \dots \dots \dots (10)$$

$$\phi_r = \frac{1 - \cos[2\pi(ICR - 1)]}{\sin[2\pi(ICR - 1)]} \dots \dots \dots (11)$$

Where, k_o = Average mesh stiffness,
 ICR = Involute Contact Ratio,
 k_s = Gear mesh stiffness during single tooth contact
 k_r and $\phi_r = r^{th}$ Fourier Coefficient and phase angle of $k(t)$, here, $R=5$.

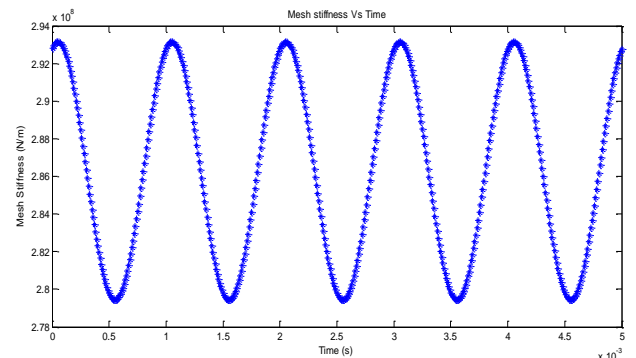

Fig.5 (a) Mesh stiffness variation for normal gears at 600 rpm

Fig.5 shows the mesh stiffness variation from the normal and phasing gears at 600 RPM which is in sinusoidal square form. From these plots, it is clear that mesh stiffness variation is reduced for phasing gears. This is

because the number of tooth pairs in contact is increased due to the phasing of gears which indicates the possibility of vibration reduction.

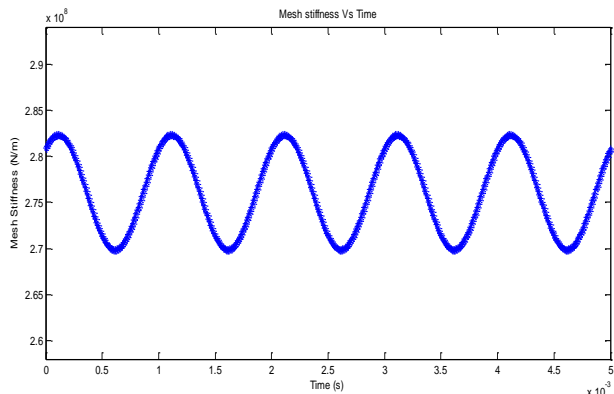

Fig.5 (b) Mesh stiffness variation for phasing gears at 600 rpm

The effect of phasing gears on mesh stiffness variation is studied analytically and the mesh stiffness variation for the normal and phasing gears is calculated using MATLAB 7.5 software as explained in Fig.5 which is in sinusoidal square form. The numerically calculated values of k_{max} , k_{min} and k_o for normal and phasing gears are summarized in the following Table 2:

Table 2 Calculated values of maximum, minimum and average mesh stiffness

	Normal gears	Phasing gears
k_{max} (N/m)	2.932×10^8	2.823×10^8
k_{min} (N/m)	2.794×10^8	2.699×10^8
k_o (N/m)	2.863×10^8	2.761×10^8

As discussed by Wadkar, *et al* (Wadkar, 2005), mesh stiffness increases when number of tooth pairs in a contact change from one to two pairs and vice versa. In normal gears, the number of tooth pairs in contact changes from one to two while in phasing gears, it changes from one to four.

Conclusions

The effects of phasing gears on time-varying gear mesh stiffness are studied in this paper. This new method of phasing gears reduced the variation in mesh stiffness which is the principle cause of vibration in gear systems and can be used to minimize the vibrations in industrial machine tool gearboxes, automobile gearboxes etc. The results of this study are analytical and should be verified experimentally.

Acknowledgements

The author wishes to thank Mr. Amol Pawar from Precision Gauging & Instruments Pvt. Ltd. Khalad and Mr. Ganesh Sonawane from Carl Zeiss India, Pune for measuring gear parameters used in this study.

References

A. Fernandez del Rincon, F.Viadero, M.Iglesias, P.García, A.de-Juan, R.Sancibrian. (2013), A model for the study of meshing stiffness in spur gear transmissions, *Mechanism and Machine Theory* 61, 30–58.

D.P.Townsend, 1992, *Dudley’s Gear Handbook*, McGraw-Hill, NewYork,

D.Richards, D.J.Pines, (2003), Passive reduction of gear mesh vibration using a periodic driveshaft, *Journal of Sound and Vibration* 264, 317–342.

G.J.Cheon, (2007), Nonlinear behaviour analysis of spur gear pairs with a one-way clutch, *Journal of Sound and Vibration* 301, 760–776.

G.J.Cheon, (2006), Effects of a one-way clutch on the nonlinear dynamic behaviour of spur gear pairs under periodic excitation, *Journal of Mechanical Science and Technology* 20 (7), 941–949.

Giorgio Bonori, Marco Barbieri, Francesco Pellicano, (2008), Optimum profile modifications of spur gears by means of genetic algorithms, *Journal of Sound and Vibration* 313, 603–616.

G.J.Cheon, (2010), Numerical study on reducing the vibration of spur gear pairs with phasing, *Journal of sound and vibration*, 329, 3915-3927.

H.N.Ozguven, D.R.Houser, (1988), Mathematical models used in gear dynamics- a review, *Journal of Sound and Vibration* 121, 383–411.

J.Lin, R.G.Parker, (2002), Mesh stiffness variation instabilities in two-stage gear systems, ASME, *Journal of Vibration and Acoustics* 124, 68–75.

J.H. Kuang, A.D. Lin, (2003), Theoretical aspects of torque responses in spur gearing due to mesh stiffness variation, *Mechanical Systems and Signal Processing*, 17 (2), 255–271.

Kahraman, A., and Blankenship, G. W., (1999), Effect of Involute Contact Ratio on Spur Gear Dynamics, ASME J. Mech. Des., 121, 112–118.

M.Vaishya, R.Singh, (2001), Analysis of periodically varying gear mesh systems with coulomb friction using floquet theory, *Journal of Sound and Vibration* 243 (3), 525-545.

S.B. Wadkar and S. R. Kajale, (2005), Theoretical evaluation of effect of gear parameters on mesh stiffness variations, *Proceedings of 14th ISME International Conference on Mechanical Engineering in Knowledge Age*, 148-153.

Y.H.Guan, T.C.Lim, W.S.Shepard Jr, (2005), Experimental study on active vibration control of a gearbox system, *Journal of Sound and Vibration* 282, 713–733.