

RF PARAMETER AND FIELD STABILITY REQUIREMENTS FOR THE CORNELL ERL PROTOTYPE

M. Liepe* and S. Belomestnykh, Cornell University, Ithaca, NY, 14853, USA

Abstract

Cornell University, in collaboration with Jefferson Laboratory, has proposed the construction of a prototype energy-recovery linac (ERL) to study the energy recovery concept with high current, low emittance beams [1, 2]. The ERL will require the operation of superconducting cavities in two extreme regimes. In the injector a multi-mA beam is accelerated to several MeV energy. The resulting high beam loading in the superconducting cavities requires a strong coupling of the fundamental mode coupler and a high power transfer. The dominating sources of field perturbation in the injector cavities are beam transients and beam current fluctuations. In the main linac the decelerated recirculated beam cancels the beam loading of the accelerated beam. Accordingly these cavities are operated at a high external quality factor to minimize the RF power requirements. Microphonic cavity detuning and path length fluctuations significantly increase the RF power demands. In this paper an overview of the prototype RF system is given and the RF power demands and field stability requirements are discussed in detail.

OVERVIEW

The schematic of the injector RF system is shown in Figure 1 (see also [3]). A bunched 100 mA, 500 keV beam of a DC gun will be compressed in a normal-conducting copper buncher and subsequently accelerated by five superconducting (s.c.) 2-cell cavities to an energy of 5.5 MeV.

The main linac with energy recovery is based on five superconducting 9-cell cavities, each with its own field control system and klystron; see Figure 2.

INJECTOR CAVITIES

Buncher Cavity:

The buncher cavity is a normal-conducting single-cell cavity made of copper. It is used to produce a correlated energy variation of about 10 keV along a $\sigma_{gun} = 12$ ps, 500 keV bunch coming from the gun. This will shorten the bunch to $\sigma_{inj} = 2.3$ ps in a drift space between the buncher cavity and first superconducting cavity. The RF properties [4] of the buncher cavity are listed in Table 1.

Power requirements: In order to maximize the energy variation along the the bunch at a given cavity accelerating voltage V_{acc} , the beam passes the buncher cavity -90° off-crest, i.e. during zero-crossing. The RF power required to maintain a constant field in the cavity is then given by

$$P_g = \frac{V_{acc}^2}{R/Q_0} \frac{(1+\beta)^2}{4\beta} \left\{ 1 + \frac{Q_0^2}{(1+\beta)^2} \left(\frac{\omega_c}{\omega} - \frac{\omega}{\omega_c} - \frac{R}{Q} \frac{I_b}{V_{acc}} \right)^2 \right\}, \quad (1)$$

*mul2@cornell.edu

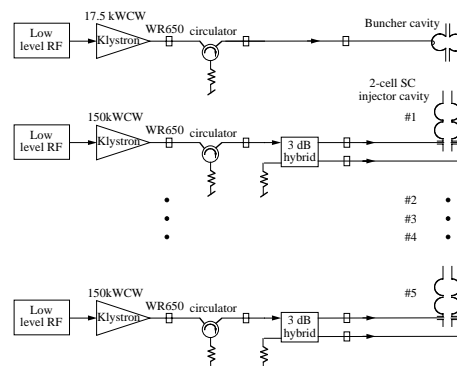

Figure 1: Schematic view of the ERL injector RF system.

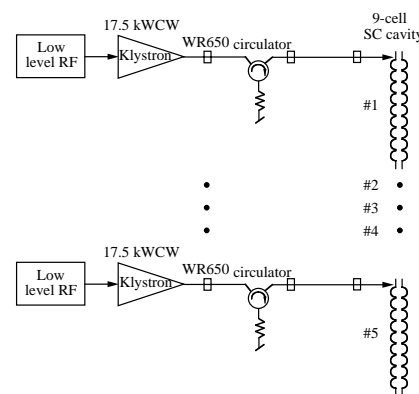

Figure 2: Schematic view of the ERL main linac RF system.

where $\beta = Q_0/Q_{ext}$ is the coupling factor of the input coupler, ω_c is the cavity eigenfrequency and ω is the RF frequency of the driving power. It is desirable to minimize the required RF drive power with and without beam passing the cavity. The short ion-clearing gaps in the beam train will not allow to retune the cavity for beam/ no beam conditions. In both cases a minimum RF power of 5.2 kW is required, if the frequency of the cavity is tuned to 1.3 GHz + 57 kHz, and if the coupling factor of the input coupler is

Table 1: RF properties of the ERL cavities.

	buncher cavity	2-cell injector	9-cell main linac
Frequency	1300 MHz	1300 MHz	1300 MHz
Num. of cells	1	2	9
R/Q	210.5 Ω	218 Ω	1036 Ω
Q_0	20,000	$> 5 \cdot 10^9$	$> 1 \cdot 10^{10}$
Q_{ext}	9,900	$4.6 \cdot 10^4$ ($4.1 \cdot 10^5$)	$2.6 \cdot 10^7$
Acc. voltage	120 kV	1MV (3MV)	$\approx 21MV$

$\beta = 2.02$. To account for waveguide losses and power overhead for control we shall add 30 % to this number. Thus the required unsaturated output power of the klystron driving the buncher cavity is 6.8 kW.

2-Cell S.C. Cavities:

Downstream of the copper buncher the beam will be accelerated by five superconducting 2-cell cavities (see [5]) to 5.5 MeV (up to 15.5 MeV for special studies). The beam passes these cavities on-crest at small bunch charges and slightly off-crest (up to 15°) for a 77 pC bunch charge to compensate space charge effects. The RF properties of the s.c. injector cavities are summarized in Table 1.

Power requirements: With optimized (matched) input coupler coupling the required RF drive power for a superconducting injector cavity is simply given by the power transferred to the beam: $P = V_{acc} I_b = 1 \text{ MV} \cdot 0.1 \text{ A} = 100 \text{ kW}$. Increasing this number by 30 % for waveguide losses and control overhead yields 130 kW as required klystron output power per cavity. As mentioned above, this requires matched coupling of the input coupler with

$$Q_{opt} = \frac{V_{acc}}{\frac{R}{Q} I_b \cos \phi_b}. \quad (2)$$

Assuming on-crest acceleration this gives $4.6 \cdot 10^4$ for the baseline energy gain of 1 MeV per cavity and $4.1 \cdot 10^5$ for a 3 MeV operation with 33 mA beam current. These relatively low values reflect the strong beam loading in the injector cavities. Because of the resulting large bandwidth, microphonics cavity detuning (usually well below 50 Hz) will give no significant increase in the RF power demand.

Stability Requirements:

Amplitude fluctuations of the buncher cavity voltage will affect the resulting bunch length. It is desirable that the bunch length does not fluctuate more than 0.1 ps (rms). This results in a modest amplitude stability requirement of $8 \cdot 10^{-3}$ (rms).

The intra-bunch energy spread behind the injector is about $\sigma_{inj} = 10 \text{ keV}$ for 5.5 MeV, 77 pC bunches (dominated by space charge effects [6]). It is desirable for the bunch-to-bunch energy fluctuation (bunch centroid energy) at the end of the injector to be well below the intra-beam energy spread. Then the total energy spread of the beam is dominated by the latter. The gun laser timing jitter, the buncher cavity as well as the five superconducting injector cavities contribute to a bunch-to-bunch energy variation in the injector. We have to separate between uncorrelated and correlated (from cavity to cavity) errors. For the ERL injector cavities the 100 mA beam loading will be dominating field perturbation, which will cause correlated field errors. Accordingly, we shall consider correlated field errors in the injector cavities. A stability of 2 ps rms is achievable for the gun laser timing jitter. This jitter is compressed by the buncher cavity to 0.1 ps (0.047° phase error at 1.3 GHz). The resulting energy error in the buncher and the five SC

injector cavities (for 15° off crest acceleration) is 0.87 keV. We require that the bunch-to-bunch energy fluctuation is increasing the total energy spread at the injector by less than 20%, i.e. to a total of 12 keV rms. Accordingly, the maximum bunch-to-bunch fluctuation is 6.6 keV. Quadratically subtracting 0.87 keV contribution of the gun timing jitter will allow for 4.7 keV energy spread contribution of the phase errors and amplitude errors each. Considering that the phase errors of the buncher cavity and the five injector cavities contribute equally, this gives a maximum allowable energy fluctuation of 2.35 keV rms from phase errors. Table 2 summarizes the resulting stability requirements in the injector. For more details refer to [7].

S.C. MAIN LINAC CAVITIES

In the main linac a 100 mA beam is accelerated by five superconducting 9-cell TESLA-style cavities (baseline layout) to a final energy of about 105 MeV (assuming 5.5 MeV injection energy), while the recirculated beam is decelerated from 105 MeV to 5.5 MeV. Each cavity is operated at an accelerating cw gradient of about 20 MV/m. The RF properties of the linac cavities are summarized in Table 1.

Depending on the machine-operating mode, the beam will pass these cavities on-crest or slightly off-crest [6]:

- (1) Minimum energy spread operation: On-crest beam acceleration results in a minimum intra-bunch energy spread of $\sigma \approx 50 \text{ keV}$.
- (2) Low emittance operation: Off-crest acceleration by about -15° gives minimum CSR emittance growth.
- (3) Short-bunch operation: Off-crest acceleration by about 15° for bunch compression in the Bates magnets results in a bunch length of about 100 fs.

Power requirements: Since the beam loading of the accelerated and decelerated beam cancel, ideally there is no effective beam loading for the accelerating cavity mode. The required RF power to maintain a given accelerating voltage V_{acc} is then

$$P_g = \frac{V_{acc}^2}{4 \frac{R}{Q} Q_{ext}} \left\{ 1 + \left(\frac{\Delta\omega 2Q_{ext}}{\omega_c} \right)^2 \right\}. \quad (3)$$

We see that the maximum power is determined by the peak microphonics cavity detuning $\Delta\omega = \omega_c - \omega$ during cavity operation; see Figure 3. Therefore passive and active

Table 2: RF stability requirements in the injector and resulting energy spread.

	gun timing jitter	buncher cavity	s.c. cavities
Ampl. stab. (rms)	-	$8 \cdot 10^{-3}$	$9.5 \cdot 10^{-4}$
Phase stab. (rms)	2ps	0.1°	0.1°
Contrib. of ampl. fluct. to energy spread	-	-	4.7 keV
Contrib. of phase fluct. to energy spread	0.87 keV	2.35 keV	2.35 keV

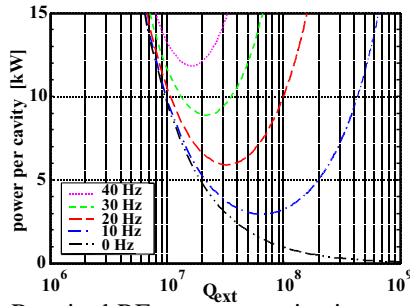

Figure 3: Required RF power to maintain an accelerating gradient of 20 MV/m in a 9-cell main linac cavity as function of the coupler external quality factor for different peak microphonic detunings.

reduction of the cavity vibration is desirable to further improve the efficiency of an ERL. From equation 3 one finds for the optimum external quality factor of the input coupler

$$Q_{opt} = \frac{1}{2} \frac{\omega_c}{\Delta\omega}. \quad (4)$$

Note that the optimum external quality factor is determined only by the peak cavity detuning. If we assume a peak detuning of 25 Hz, we find $Q_{opt} = 2.6 \cdot 10^7$. According to equation 3 the required RF power is then $P_g \approx 8$ kW per 9-cell cavity with $V_{acc} = 21$ MV.

While beam loss within reasonable limits gives no significant increase in RF power demands, a small phase error $\delta\phi$ of the recirculated beam does. Ideally the recirculated beam is decelerated at an RF phase shifted by 180° relative to the phase at which the initial beam is accelerated. Any deviation $\delta\phi$ from this ideal condition results in a effective beam current in the main linac cavities (complex vector representation)

$$I_{eff} = I_{acc}(1 - e^{i\delta\phi}) \approx -iI_{acc}\delta\phi, \quad (5)$$

where I_{acc} is the average current of the accelerated beam. As a result of a non-zero current, the required RF power to maintain a given field increases; see Figure 4. Proper cavity detuning is required to minimize the RF power demand. Path length errors of the recirculated beam and a phase slip along the linac due to a not fully relativistic beam will contribute to a phase error $\delta\phi$ of up to 1° in some cavities.

Stability requirements: In short bunch operation the beam is accelerated off-crest by about 15° and subsequently the bunches are compressed from $\sigma = 2.3$ ps to $\sigma \approx 100$ fs in bending magnets [6]. We shall require that the timing jitter of the bunch-centroids after the compression should not exceed the length of a single bunch. This translates to a required bunch-to-bunch energy stability of $2 \cdot 10^{-4}$ or 20 keV at the end of the linac ($R_{56} = 15$ cm). A bunch-to-bunch energy fluctuation of less than 30 keV is also desirable for on-crest operation, because then the total beam energy spread is dominated by the intra-bunch energy spread of $\sigma \approx 50$ keV.

We may neglect contributions from the injector cavities to the energy spread in the following. Further, we can neglect contributions resulting from the timing jitter of the

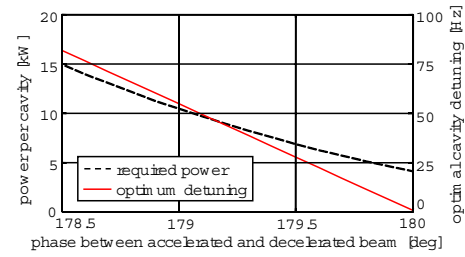

Figure 4: Required RF power to maintain an accelerating gradient of 20 MV/m in a main linac cavity in presence of a phase error of the recirculated beam. Also shown is the optimum detuning needed to minimize the RF power demands. The accelerating phase is -15° .

bunches after the injector; see [7]. Microphonics cavity detuning will be one of the major field perturbations in the ERL main linac, and previous measurements at the Tesla-Test-Facility linac indicate that this effect is not correlated between the cavities. Therefore we will assume non-correlation for the field errors in the five main linac cavities. It should be noted that this assumption has to be verified at the ERL prototype, since it has major impact on the field stability requirements in a large scale facility. Assuming further equal contributions ($20keV/\sqrt{10} \approx 6$ keV per cavity) from amplitude and phase errors we find an rms amplitude stability requirement of (15° off crest acceleration)

$$\frac{\sigma_A}{A} = \frac{\sigma_E}{eV_{acc} \cos \phi_b} = \frac{6keV}{e21MV \cos(15^\circ)} \approx 3 \cdot 10^{-4} \quad (6)$$

for the field in the main linac cavities. The required rms phase stability is

$$\sigma_\phi = \frac{\sigma_E}{eV_{acc} \sin \phi_b} = \frac{6keV}{e21MV \sin(15^\circ)} \approx 0.06^\circ. \quad (7)$$

CONCLUSIONS

The RF power demands and field stability requirements have been estimated for the Cornell ERL prototype. The stability requirements are demanding, and a fast digital RF controller is under development to address these challenges [8].

REFERENCES

- [1] Study for a proposed Phase I ERL Synchrotron Light Source at Cornell University, ed. by S. Gruner and M. Tigner, CHESS Tech. Memo 01-003, JLAB-ACT-01-04 (July 2001)
- [2] C. Sinclair et al., this conference, paper TOAC005.
- [3] H. Padamsee et al., this conference, paper TPAB052.
- [4] V. Veshcherevich, this conference, paper TPAB008.
- [5] V. Shemelin et al., this conference, paper WPAB012.
- [6] I. Bazarov, private communications.
- [7] S. Belomestnykh, M. Liepe, Cornell ERL Note 2003-01.
- [8] M. Liepe et al., this conference, paper FPAB027.