

# Recovery of Prostacyclin Production by De-endothelialized Rabbit Aorta

## CRITICAL ROLE OF NEOINTIMAL SMOOTH MUSCLE CELLS

AMIRAM ELDOR, DOMENICK J. FALCONE, DAVID P. HAJJAR, C. RICHARD MINICK, and  
BABETTE B. WEKSLER, *Departments of Medicine and Pathology, The New  
York Hospital-Cornell Medical Center, New York, 10021*

**ABSTRACT** Prostacyclin (PGI<sub>2</sub>) synthetic capacity was assayed at the surface of aortas at various intervals after removal of endothelium with a balloon catheter. Results were correlated with morphologic changes in the vessel wall seen by light microscopy, scanning and transmission electron microscopy. To assay PGI<sub>2</sub> synthetic capacity, we applied an incubation chamber to the luminal surface of the aortas; after arachidonic acid stimulation we assayed the PGI<sub>2</sub> synthesized with a bioassay and radioimmunoassay. PGI<sub>2</sub> synthesis in de-endothelialized aortas was determined immediately after balloon-catheter injury and at intervals of 1 h and 2, 4, 15, 35, and 70 d. PGI<sub>2</sub> synthesis was low at 1 h and increased over time with levels at 35 and 70 d reaching that of normal artery. Scanning and transmission electron microscopy of de-endothelialized areas showed persistent absence of endothelium with formation of a neointima composed of smooth muscle cells. De-endothelialized aorta was covered with adherent platelets shortly after injury, however several days later only a few platelets adhered to the denuded surface.

Results indicated that (a) endothelium is responsible for nearly all PGI<sub>2</sub> production at the luminal surface of the normal aorta, (b) de-endothelialized muscular neointima synthesized increasing quantities of PGI<sub>2</sub> with time after injury, and (c) increase of PGI<sub>2</sub>

production at the luminal surface of de-endothelialized aorta correlates with formation of a neointima and with the acquired thromboresistance of the aorta.

### INTRODUCTION

Endothelial cells form a thromboresistant surface between the circulating blood and the underlying vessel wall. Several mechanisms have been proposed to explain the thromboresistant character of this endothelial surface. These include (a) electrostatic repulsion of blood cells by endothelial cells (1), (b) synthesis of plasminogen activator (2-5), (c) synthesis of an ecto-ADPase (6-8), and (d) synthesis of heparan sulfate (9-11). The recent finding that endothelial cells synthesize prostacyclin (PGI<sub>2</sub>)<sup>1</sup> suggests another possible mechanism to explain the lack of platelet reactivity with endothelium (12-14).

When endothelium is removed from the aortic wall, platelets immediately adhere to the exposed subendothelium, forming a carpetlike layer covering the entire luminal surface (15-17). However, if similar de-endothelialized areas are examined several days after endothelial removal, relatively few platelets adhere to the vascular surface (18, 19). The acquired thromboresistance of the de-endothelialized aortic wall is particularly interesting in view of the fact that endothelium is generally regarded as the only thromboresistant structure of blood vessels. The mechanism underlying the change in platelet reactivity of de-endothelialized aortic wall has not been well investigated.

Experiments reported here were conducted using an incubation chamber to measure the concentration of PGI<sub>2</sub> at the luminal surface of aortas at various intervals after endothelial removal. We used this new tech-

---

This work was presented in part to a meeting in December 1979 of the American Society of Hematology, Phoenix, Ariz.

Dr. Eldor is on sabbatical leave from the Department of Hematology, Hadassah University Hospital, Jerusalem, Israel and is supported by a fellowship from C. and Y. Jurzykowski. Dr. Weksler is a recipient of an American Heart Association research grant and an American Cancer Society Faculty Research Award. Dr. Hajjar is a recipient of a research fellowship from the National Institutes of Health. Address reprint requests to Dr. Minick.

Received for publication 6 May 1980 and in revised form 10 October 1980.

---

<sup>1</sup>Abbreviations used in this paper: PGF<sub>1α</sub>, prostaglandin F<sub>1α</sub>; PGI<sub>2</sub>, prostacyclin; SEM, scanning electron microscopy; TEM, transmission electron microscopy.

nique to test the hypothesis that increased PGI<sub>2</sub> production may be one important mechanism contributing to the acquired thromboresistance that develops with time in de-endothelialized aorta.

## METHODS

**Removal of endothelium.** Endothelium was removed from rabbit aortas by the method of Baumgartner et al. (20). A 4F thin-walled Fogarty embolectomy-catheter (Edwards Laboratory, Santa Ana, Calif.) was inserted into the right femoral artery of anesthetized rabbits and pushed into the proximal aorta. The balloon was then inflated to a pressure of 450–500 mm Hg and the inflated catheter was pulled through the aorta three times.

**Experimental groups.** 71 young female adult white New Zealand rabbits weighing 2,500–3,500 g were fed commercial rabbit ration (Purina Rabbit Chow, Ralston Purina Co., St. Louis, Mo.) and water ad lib. Rabbits were randomly divided into two groups. Group I consisted of 13 untreated control rabbits. Using the technique outlined below, capacity for PGI<sub>2</sub> synthesis was assessed at the endothelial surface of their aortas. Group II consisted of 49 rabbits and was divided into two subgroups, IIA and IIB. Aortas from rabbits of Group IIA were used to assess capacity for PGI<sub>2</sub> synthesis at the de-endothelialized and uninjured luminal surface. Aortas of rabbits of Group IIB were perfuse-fixed for scanning (SEM) and transmission (TEM) electron microscopy. Of the 35 rabbits in Group IIA, 2 were de-endothelialized immediately after killing and the remaining rabbits were killed as follows: six at 1 h, 5 at 2 d, 4 at 4 d, 5 each at 15 and 35 d, and 4 at 70 d after de-endothelialization. In addition, aortas of two rabbits were de-endothelialized with collagenase and two with mechanical abrasion using a gauze sponge. Of the 14 rabbits in Group IIB, 2 were de-endothelialized immediately after sacrifice and the remaining rabbits, 3 at each interval, were sacrificed at 1 and 48 h, and 15 and 35 d. For purposes of comparison, aortas of nine additional rabbits, five uninjured and four injured were used to assess PGI<sub>2</sub> production in full-thickness punch biopsies of aorta.

**Autopsy procedures.** To distinguish between de-endothelialized aortic luminal surface and surface covered by endothelium, all rabbits were injected intravenously 1 h before killing with 3 ml/kg of a 0.5% (wt/vol) solution of the protein-binding azo dye Evans blue (21) (Harvey Laboratories, Philadelphia, Pa.). Rabbits of Group I and group IIA were killed by an overdose of sodium pentobarbital. Aortas of these rabbits were dissected from adjacent tissues and maintained, until assayed for PGI<sub>2</sub>, at 4°C in ice cold Hepes buffered saline, pH 7.5, containing 1 mM MgCl<sub>2</sub> and 1.8 mM CaCl<sub>2</sub>. Rabbits of Group IIB were killed by perfusion with glutaraldehyde while under deep pentobarbital anesthesia. They were perfused at 100 mm Hg via the left ventricle with efflux from a vena caval catheter, using Ringer's solution for 2 min, followed by 1% glutaraldehyde in Sorenson's phosphate buffer, pH 7.4, for 40 min at 37°C. While continuing to be fixed in 1.5% glutaraldehyde, aortas were opened along the anterior wall to expose the luminal surface.

**Preparation of aortic tissue for microscopy.** In animals of Group IIB, full-thickness tissue specimens of aorta were dissected at standard sites for SEM and TEM. Tissue specimens for electron microscopy were taken from de-endothelialized blue areas, white zones of re-endothelialized islands, and from transitions between these zones and areas. (See Results). These tissues were washed in several changes of 0.1 M calcium cacodylate buffer, pH 7, and processed for SEM and TEM as described (21). Specimens for SEM were viewed

in an ETEC autoscan (ETEC Corp., Hayward, Calif.) and those for TEM in a Philips 301 microscope (Philips Electronic Instruments, Mahwah, N. J.).

**PGI<sub>2</sub> synthesis by rabbit aorta.** Two methods were used to assay PGI<sub>2</sub> synthetic capacity of the aortic wall. We sampled randomly chosen areas of luminal surface of uninjured or de-endothelialized aortas because extensive sampling in preliminary experiments indicated no regional difference in PGI<sub>2</sub> production along the abdominal and thoracic aorta. In the first method de-endothelialized or uninjured portions of aorta were placed between two lucite plates that were held together with two lateral screws (Fig. 1). The upper lucite plate contained an elliptical hole (6 × 13 mm) that was narrower than the aortic width, and served as an incubation chamber in which the aortic luminal surface formed the chamber base. Leakage of fluid from this chamber was prevented by a rubber washer attached to the bottom of the upper plate. The possibility of leakage in or out of the incubation chamber was tested in two ways. Evans blue dye placed in the chamber did not diffuse out of the well. PGI<sub>2</sub> placed in one of three incubation chambers of a multi-welled lucite plate was not detected in the other two wells. The remaining aorta, outside the chamber, was immersed in cold Hepes buffer. The aortic surface within the incubation chamber was washed with warm Hepes buffer (37°C). Then, to assay PGI<sub>2</sub> production, 15 mM Tris prepared in physiologic saline, pH 8.6, containing 27 μM arachidonic acid, was warmed to 37°C and placed in the incubation chamber for 2 min. The buffer alone did not stimulate PGI<sub>2</sub> production during the incubation period; it did preserve PGI<sub>2</sub> biological activity because of the alkaline pH. The temperature in the chamber did not fall below 35°C during the incubation period. Aortic incubation fluid was then collected, frozen immediately in a dry-ice acetone bath and maintained at -70°C until assayed. For comparison, a second assay method was used that employed full-thickness punch biopsies of aortic wall, measuring 6 mm in diameter and weighing ~15 mg. These biopsies were incubated at 37°C for 2 min in test tubes containing 15 mM Tris-HCl buffer, pH 8.6, plus 27 μM arachidonic acid. After incubation, the tissue was removed; the aortic incubation fluid was frozen and stored as described above. To determine if recently de-endothelialized aorta degrades PGI<sub>2</sub> to metabolic products other than 6-keto-prostaglandin (PG)F<sub>1α</sub>, we placed a measured quantity of PGI<sub>2</sub> in the incubation chamber on the aorta and measured PGI<sub>2</sub> or 6-keto-PGF<sub>1α</sub> at 2 min.

**Quantitation of PGI<sub>2</sub>.** This was performed using our modification of the thrombin-induced serotonin release assay first described by Baenziger et al. (22). This assay measures inhibition by PGI<sub>2</sub> of thrombin-induced [<sup>14</sup>C]serotonin release from

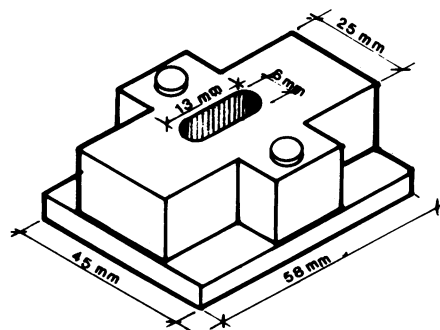

FIGURE 1 Mechanical drawing of incubation chamber used for PGI<sub>2</sub> assay.

prelabeled, washed, aspirin-treated platelets. This assay has been described in detail (13).

In these experiments, PGI<sub>2</sub> synthesis was also assessed by measurement of PGI<sub>2</sub> in aortic incubation fluids with a radioimmunoassay for 6-keto-PGF<sub>1α</sub>. PGI<sub>2</sub> in the aortic incubation fluid was converted to 6-keto-PGF<sub>1α</sub> by acidification to pH 3 with 1 N HCl and/or incubation for 1 h at 37°C. No residual biological activity of PGI<sub>2</sub> remained as tested by the inhibition of platelet aggregation. Antisera against authentic 6-keto-PGF<sub>1α</sub> conjugated to keyhole limpet hemocyanin were developed in rabbits. Incubation mixtures included 100 μl <sup>3</sup>H-6-keto-PGF<sub>1α</sub> (10,000 dpm; sp act 100 Ci/mmol, New England Nuclear Corp., Boston, Mass.), 100 μl test sample and 100 μl antiserum at a dilution (1:3200) which bound 50% of the radioactivity in the absence of standard. All dilutions were made using 50 mM Hepes buffer, pH 7.5, containing 0.2% bovine serum albumin. After the mixture was incubated for 18 h at room temperature, the bound radioactivity was separated from residual activity by the addition of *Staphylococcus aureus* Protein A (Pansorbin, Calbiochem-Behring Corp., American Hoechst Corp., San Diego, Calif.) followed by centrifugation at 3,000 g for 30 min. 300 μl of supernatant fluid was added to 6 ml Biofluor (New England Nuclear Corp.) and radioactivity was measured (13). Standard curves were run with each assay using 6-keto-PGF<sub>1α</sub> standards. (Authentic PGI<sub>2</sub> and 6-keto-PGF<sub>1α</sub> were generous gifts of Dr. John Pike, Upjohn Co., Kalamazoo, Mich.). These were interchangeable with PGI<sub>2</sub> standards. This assay had low (<1%) cross-reactivity with other prostaglandins which was similar to other radioimmunoassays reported previously (23).

**Statistical analysis.** Aortic-surface PGI<sub>2</sub> synthesis in Group I rabbits was compared with synthesis measured in de-endothelialized areas of Group IIA rabbits using a single-factor analysis of variance. Inasmuch as testing for homogeneity of variances demonstrated significant differences using Bartlett's test, the data were log transformed ( $x' = \log(x + 1)$ ). A nonparametric analysis of variance (Kruskal-Wallis) was also performed. If significant differences in PGI<sub>2</sub> production were detected by analysis of variance using log transformed data, subsequent pair-wise comparisons were performed using Duncan's multiple range test (24, 25).

Mean quantities of PGI<sub>2</sub> produced by aortic punch biopsies from uninjured aortas and de-endothelialized aortas were compared using an independent *t* test. To prevent bias in the data analyzed, PGI<sub>2</sub> synthesis assayed in replicate biopsies or surface incubations of the same aorta were averaged to give a single value for each animal.

Correlation between PGI<sub>2</sub> assessed by the thrombin-induced serotonin release assay and 6-keto-PGF<sub>1α</sub> assessed by the radioimmunoassay was tested by the Pearson product-moment correlation analysis (*r*) (24).

## RESULTS

**Macroscopic observations.** All rabbits were injected with Evans blue dye. Unballooned aortas of Group I rabbits did not stain. The luminal surface of previously de-endothelialized aortas showed changes similar to those described (21). A sharp transition was observed between the unballooned segment of the aorta that remained unstained and the more distal segment that had been previously de-endothelialized and stained blue. This latter segment extended from just cephalad to the first intercostal artery to the bifurcation of the abdominal aorta. The entire luminal surface

stained blue in aortas of animals de-endothelialized 1 h, 48 h, or 4 d before killing. Aortas of animals de-endothelialized 15, 35, or 70 d before killing revealed grossly distinguishable areas that stained with Evans blue dye, surrounding islands or bands that remained unstained, nonblue areas. Re-endothelialized, nonblue areas were present in the same distribution in all animals killed at the same interval and often surrounded the ostia of aortic branch vessels.

**Microscopic observations.** As seen with light microscopy, SEM, and TEM, the normal aorta showed intact endothelium and no intimal thickening or adherent platelets (Figs. 2a, b, and c). The luminal surface of aorta of the animals that were killed and immediately de-endothelialized revealed general loss of endothelium with exposure of basement membrane (not shown). Occasional widely scattered platelet aggregates were present on the surface. In aortas of animals de-endothelialized either 1 or 48 h before killing, the luminal surface was completely covered by a layer of platelets mixed with occasional leukocytes (Figs. 2d, e, and f). Aortas of rabbits de-endothelialized 15, 35, and 70 d before killing revealed a luminal surface variously lined by a neointima consisting of vascular smooth muscle cells without covering endothelium, blue de-endothelialized areas (Figs. 2g, h, and i) or a similar neointima covered by endothelial cells. The smooth muscle cells lining blue areas often had multiple bleb-like projections on their luminal surface (Figs. 2h and i). In contrast to animals sacrificed at 1 or 48 h, aortas of animals sacrificed at 15, 35, or 70 d revealed only occasional widely separated aggregates of platelets adhering to the luminal surface of blue areas. The neointima of nonblue islands was covered by endothelium. There were no platelets on the endothelial surface of the nonblue islands.

**Characterization of platelet inhibitor.** Thrombin-induced [<sup>14</sup>C]serotonin release from prelabeled aspirin-treated platelets was inhibited by aortic incubation fluid obtained from uninjured and some de-endothelialized aortas by the two methods described. This inhibiting activity was ended when fluids were incubated at room temperature for 30 min, boiled for 15 s, or briefly acidified to pH 3.0. Inhibiting activity was also ended in tissues preincubated for 10 min with the specific PGI<sub>2</sub> synthetase inhibitors tranilcypromine or 15-hydroperoxy-arachidonic acid, which were gifts, respectively, of Dr. Green (Smith Kline & French Co., Philadelphia, Pa.), and Dr. Marcus (New York Veterans Administration Hospital, New York). Results obtained with the bioassay for PGI<sub>2</sub> correlated closely with those obtained by radioimmunoassay for 6-keto-PGF<sub>1α</sub> ( $r = 0.82, P < 0.001$ ).

**PGI<sub>2</sub> production by uninjured aorta and de-endothelialized aorta.** When PGI<sub>2</sub> production was assayed at the aortic luminal surface, there were marked dif-

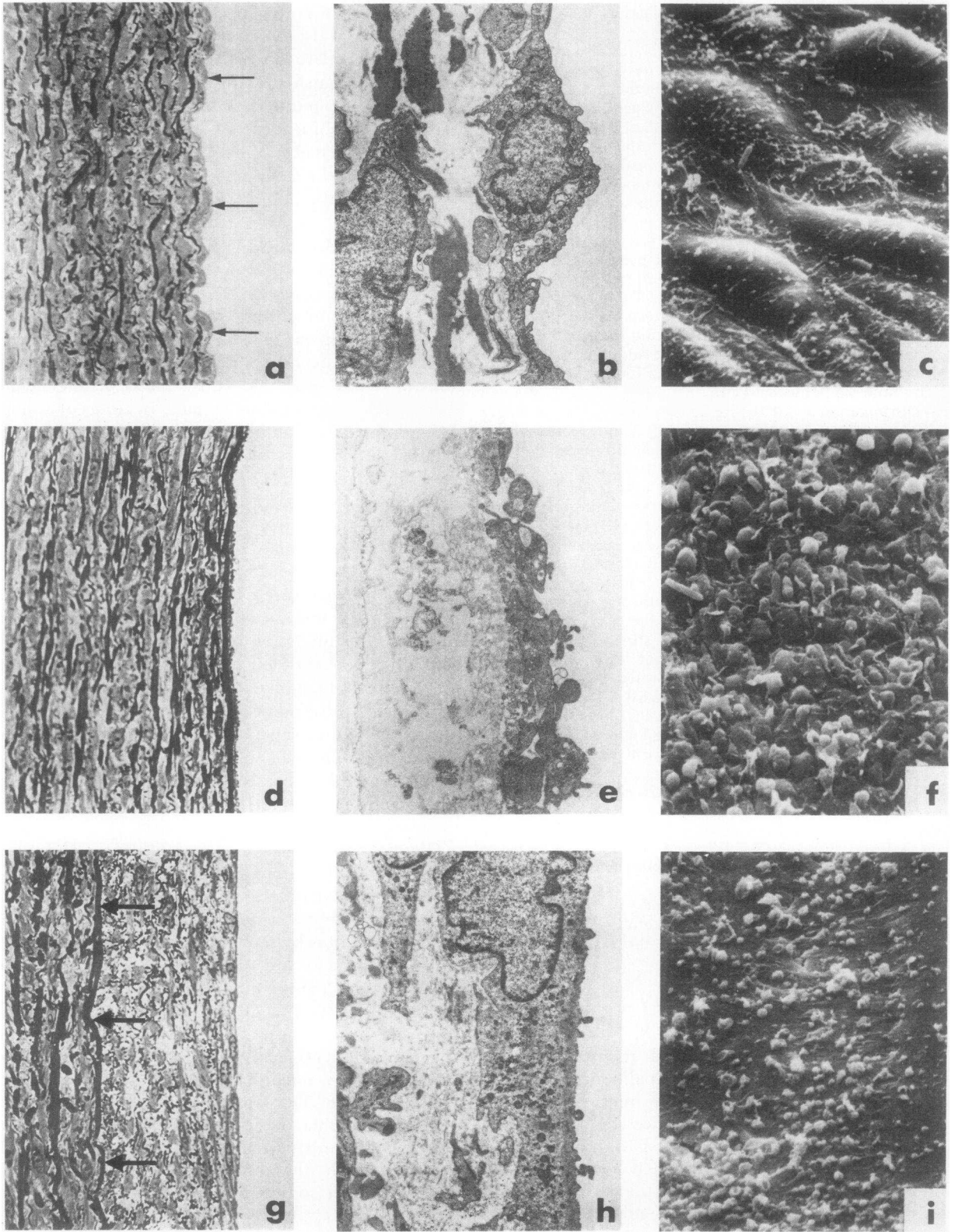

**FIGURE 2** As seen by light microscopy (arrows) (a), TEM (b), and SEM (c), the wall of the normal artery is covered by endothelial cells. There is no intimal thickening and platelets are not present

ferences in the quantity of PGI<sub>2</sub> synthesized by uninjured as compared with recently de-endothelialized aorta. Experiments performed with this method on uninjured aortas of 13 animals and de-endothelialized aortas of 5 animals killed 48 h after balloon injury revealed that uninjured aortas synthesized 16.5±4.3 ng/ml PGI<sub>2</sub> (mean±SEM) in contrast to the de-endothelialized aortas, which synthesized only 1.1±0.7 ng/ml PGI<sub>2</sub> (*P* < 0.001). The mean PGI<sub>2</sub> production in aortas of rabbits de-endothelialized after death was 0.1±0.01 ng/ml. Aortas of these latter animals were washed free of blood by saline perfusion before ballooning and hence there was little or no interaction between cellular elements of the blood and the luminal surface. Results were similar with aortas de-endothelialized by balloon catheter, by collagenase treatment, or by wiping with gauze. The de-endothelialized aortic surface did not degrade PGI<sub>2</sub> or 6-keto-PGF<sub>1α</sub> to other substances. Tissue staining with Evans blue dye did not affect the assay for PGI<sub>2</sub>. In contrast to the results obtained with the template method, when PGI<sub>2</sub> production was assayed in full-thickness punch biopsies of aorta, we were unable to demonstrate any difference in PGI<sub>2</sub> synthesis in uninjured aortas of five rabbits as compared with de-endothelialized aortas of four rabbits assayed 48 h after balloon injury. Punch biopsies of uninjured aortas synthesized 8.0±0.4 ng/ml PGI<sub>2</sub> and biopsies of de-endothelialized aortas synthesized 7.9±1.8 ng/ml.

In subsequent experiments, PGI<sub>2</sub> production by de-endothelialized areas was measured at the aortic luminal surface immediately after balloon-catheter injury and at intervals of 1 h, and 2, 4, 15, 35, and 70 d. The amounts were 0.1±0.01, 0.3±0.1, 1.1±0.7, 2.7±0.3, 4.9±2.2, 10.3±2.2, and 13.7±3.8 ng/ml, respectively. Thus, as shown in Fig. 3, PGI<sub>2</sub> production was initially low, and increased exponentially with time. PGI<sub>2</sub> production at 15 d was significantly increased as compared with 0 time. PGI<sub>2</sub> production by the neointima at 35 or 70 d was not significantly different from the normal aorta.

## DISCUSSION

We have used a new technique to assay for PGI<sub>2</sub> synthesis and release at the luminal surface of normal and de-endothelialized arterial wall. Results of these experiments indicate that as compared with normal artery, (a) PGI<sub>2</sub> production is markedly decreased

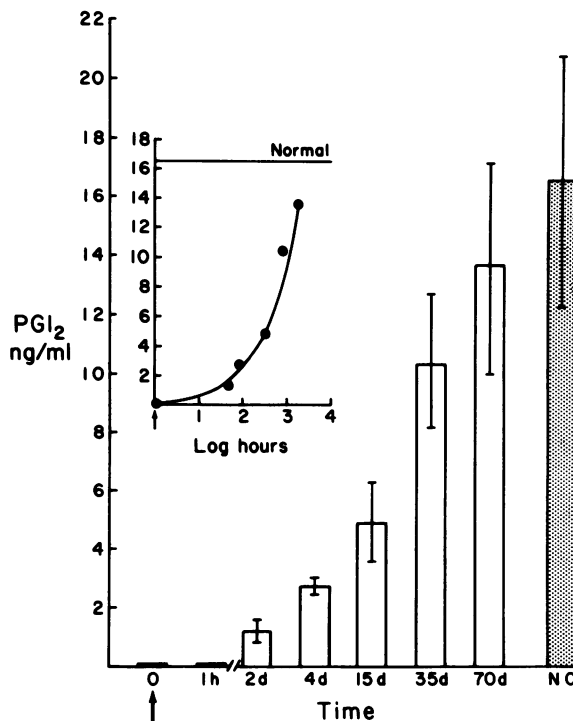

FIGURE 3 PGI<sub>2</sub> production by de-endothelialized rabbit aorta. After injury, PGI<sub>2</sub> synthesis is markedly decreased as compared with normal aorta. The de-endothelialized aortas synthesize increased quantities of PGI<sub>2</sub> with time after injury. PGI<sub>2</sub> production expressed on a continuous time scale (inset) demonstrates an exponential relationship. At 35 and 70 d after injury, smooth muscle cells in the neointima synthesize amounts of PGI<sub>2</sub> comparable to normal artery. For de-endothelialized aorta (□) at time 0, *n* = 2; 1 h, *n* = 6; 2 d, *n* = 5; 4 d, *n* = 4; 15 d, *n* = 5; 35 d, *n* = 5; 70 d, *n* = 4; and for normal controls (NC, shaded bar) *n* = 13. ↑, time of injury.

in the recently de-endothelialized aortic wall, (b) smooth muscle cells forming the neointima produce and release increasing quantities of PGI<sub>2</sub> onto the luminal surface over time, paralleling the increased thickness of the neointima, and (c) recovery of PGI<sub>2</sub> synthesis is temporally associated with recovery of thromboresistance by the de-endothelialized aortic wall.

The technique that we have used to assess prostaglandin production by the arterial tissue has several advantages as compared with arterial strips or rings that have been conventionally used (26, 27). First, this technique is more physiological in that it allows us to assay the activity of prostaglandin at the luminal surface of the vessel wall where these substances affect

on the endothelial surface. 1 h after de-endothelialization the endothelium is absent (d) and as seen by TEM and SEM, the wall of the artery is covered by a layer of platelets (e, f). At 35 d after catheter injury there is thickening of the fibromuscular neointima (arrows indicate boundary of intima and media) (g), and the neointima is lined by smooth muscle cells that have protrusions on the luminal surface (h, i). Even though the endothelium is absent, there are no platelets on the surface (h, i). (2a-i; ×375, ×6000, ×2500, ×450, ×7000, ×2500, ×750, ×5700 and ×2600).

platelets and platelet-vessel interactions. The capacity for production of PGI<sub>2</sub> with time following injury and during repair of blood vessel walls has been correlated with events at the luminal surface, e.g. platelet-blood vessel interaction. Second, this technique eliminates the contribution of prostaglandins made by smooth muscle cells exposed at the cut edge of specimen (as is the case when rings or strips of arterial tissue were incubated with arachidonic acid). Third, the technique eliminates the possible stimulation of prostaglandin synthesis by acute mechanical injury resulting from punch biopsies or cutting arterial strips or rings (27). All of these advantages were confirmed by the finding that the present technique was able to differentiate between de-endothelialized aorta and normal aorta, whereas the full-thickness punch-biopsy technique was not.

There was markedly diminished capacity of the aortic surface to synthesize PGI<sub>2</sub> in animals de-endothelialized 1 and 48 h before killing. Similar findings were seen in aortas of animals that were first perfused with Ringer's solution, killed, and then de-endothelialized to control for (a) an effect of platelet-derived endoperoxides on synthesis of PGI<sub>2</sub> by the underlying vascular smooth muscle cells, and (b) inhibition of penetration of arachidonic acid into the vessel wall by the platelet carpet which adheres to the luminal surface of vessels immediately after balloon injury in vivo. Thus, these experiments furnish strong evidence to indicate that in the normal intact artery, the endothelium is responsible for nearly all of the PGI<sub>2</sub> released at the luminal surface.

We found, unexpectedly, that the de-endothelialized aorta recovered its capacity to produce PGI<sub>2</sub> with time before restoration of a new endothelium, and by 35–70 d, it had a similar capacity to produce PGI<sub>2</sub> onto the luminal surface as did normal artery. Acquisition of this capacity correlates with the formation of a neointima of smooth muscle cells (28, 29) and indicates that with time, intimal smooth muscle cells in de-endothelialized aorta synthesize and secrete increased PGI<sub>2</sub> into the lumen. This is consistent with the finding that smooth muscle cells tested in vitro possess the capacity to synthesize PGI<sub>2</sub> (30) and that enzymes responsible for synthesis of PGI<sub>2</sub> are present in all layers of the vessel wall (31). Conceivably, this increase in PGI<sub>2</sub> production by neointimal smooth muscle cells could result either from increased enzyme activity or from increased access of substrate to smooth muscle cells. Whatever the mechanism, the acquisition of PGI<sub>2</sub> production by smooth muscle cells in the vessel wall may have important implications for the response of the arterial wall to injury and subsequent repair.

It is reasonable to suggest that synthesis of PGI<sub>2</sub> by intimal smooth muscle cells may contribute significantly to the acquired thromboresistance of the arterial

wall since it has been shown previously that PGI<sub>2</sub> can prevent adhesion of platelets to the subendothelium in vitro (32–34). Moncada et al. (31) suggest that the nonthrombogenicity of the endothelial lining is mainly the result of production of PGI<sub>2</sub>. Pretreatment of rabbits with high doses of aspirin, which completely blocked PGI<sub>2</sub> synthesis in vessels, significantly augmented the size of experimentally induced venous thrombi. A lower dosage of aspirin, which produced less inhibition of PGI<sub>2</sub>, did not produce this effect. Local instillation of tranlylcypromine, an inhibitor of PGI<sub>2</sub> synthesis, also significantly augmented thrombus size (35). However, in in vitro and in vivo systems, Cazenave et al. (36) and Dejana et al. (37) found that aspirin treatment did not promote platelet adherence to the endothelial lining or to subendothelium of the rabbit aorta. Thus conflicting observations exist in different systems as to the function of PGI<sub>2</sub> in thromboresistance. Although the temporal association of increased synthesis of PGI<sub>2</sub> with increased thromboresistance of de-endothelialized luminal surface suggests a cause and effect relationship, it is not possible to make this conclusion from results of these experiments because the relative contributions of PGI<sub>2</sub> and other factors to the thromboresistance of the normal artery and the de-endothelialized artery are not known. Definitive in vivo studies will be needed to clarify the relative roles of PGI<sub>2</sub> and other factors in the natural and acquired thromboresistance of the normal and abnormal vessel wall.

In conclusion, results of our experiments indicate (a) that endothelium is responsible for nearly all PGI<sub>2</sub> production at the luminal surface of the normal artery, and (b) smooth muscle cells in the neointima acquire the ability to produce increasing quantities of PGI<sub>2</sub> with time. Findings suggest that this acquisition of PGI<sub>2</sub> production by vascular smooth muscle may contribute importantly to the acquired thromboresistance of de-endothelialized aorta.

#### ACKNOWLEDGMENTS

The technical assistance of Charles Dorso, Karen Tack-Goldman, Joan Davol, John Shuman, Alice Hafner and Douglas Cohn is gratefully acknowledged. We are particularly grateful to Dr. Eric Jaffe for his advice. We thank Ms. Carol Ibsen and Ms. Naomi Nemtsov for assistance in the preparation of this manuscript.

This work was supported by the National Institutes of Health through a research grant for a Specialized Center for Thrombosis Research HL-18828, a research grant from the Heart, Lung, and Blood Institute HL-01803, and by grants from the Arnold R. Krakower Hematology Foundation and The Cross Foundation.

#### REFERENCES

1. Sawyer, P. N., J. W. Pate, and C. S. Weldon. 1953. Relations of abnormal and injury electric potential differences to intravascular thrombosis. *Am. J. Physiol.* 175: 108–112.
2. Loskutoff, D. J., and T. S. Edgington. 1977. Synthesis of



- a fibrinolytic activator and inhibitor by endothelial cells. *Proc. Natl. Acad. Sci. U. S. A.* **74**: 3903-3907.
3. Markwardt, F., and H. P. Klocking. 1977. Heparin-induced release of plasminogen activator. *Haemostasis*. **6**: 370-374.
  4. Levin, E. G., and D. J. Loskutoff. 1979. Comparative studies of the fibrinolytic activity of cultured vascular cells. *Thromb. Res.* **15**: 869-878.
  5. Emeis, J. J. 1979. The vascular wall and fibrinolysis. *Haemostasis*. **8**: 332-339.
  6. Habliston, D. L., U. S. Ryan, and J. W. Ryan. 1978. Endothelial cells degrade adenosine-5-diphosphate. *J. Cell Biol.* **79**: 206a.
  7. Dieterle, Y., C. Ody, and A. Ehrensberger. 1978. Metabolism and uptake of adenosine triphosphate and adenosine by porcine aortic and pulmonary endothelial cells and fibroblasts in culture. *Circ. Res.* **42**: 869-876.
  8. Pearson, J. D., and J. L. Gordon. 1979. Vascular endothelial and smooth muscle cells in culture selectively release adenine nucleotides. *Nature (Lond.)*. **281**: 384-386.
  9. Gamse, G., H. G. Fromme, and H. Kresse. 1978. Metabolism of sulfated glycosaminoglycans in cultured endothelial cells and smooth muscle cells from bovine aorta. *Biochim. Biophys. Acta*. **544**: 514-528.
  10. Barnhart, M. I., and C. A. Baechler. 1978. Endothelial cell physiology, perturbations and responses. *Semin. Thromb. Hemostasis*. **7**: 50-86.
  11. Buonassisi, V., and M. Root. 1975. Enzymatic degradation of heparin-related mucopolysaccharides from the surface of endothelial cell cultures. *Biochim. Biophys. Acta*. **385**: 1-10.
  12. Weksler, B. B., A. J. Marcus, and E. A. Jaffe. 1977. Synthesis of prostaglandin I<sub>2</sub> (prostacyclin) by cultured human and bovine endothelial cells. *Proc. Natl. Acad. Sci. U. S. A.* **74**: 3922-3926.
  13. Weksler, B. B., C. W. Ley, and E. A. Jaffe. 1978. Stimulation of endothelial cell prostacyclin by thrombin, trypsin, and ionophore A-23187. *J. Clin. Invest.* **62**: 923-930.
  14. Marcus, A. J., B. B. Weksler, and E. A. Jaffe. 1979. Synthesis of prostacyclin by cultured endothelial cells. In *Prostacyclin*. J. R. Vane and S. Bergstrom, editors. Raven Press, New York. 65-73.
  15. Baumgartner, H. R. 1974. The subendothelial surface and thrombosis. Thrombosis: pathogenesis and clinical trials. *Thromb. Diath. Haemorrh.* **59**(Suppl.): 91-106.
  16. Stemerman, M. B., and R. Ross. 1972. Experimental arteriosclerosis. I. Fibrous plaque formation in primates, an electron microscope study. *J. Exp. Med.* **136**: 769-789.
  17. Mustard, J. F., M. A. Packham, and R. L. Kinlough-Rathbone. 1978. Platelets and thrombosis in the development of atherosclerosis and its complications. In *Thrombosis: Animal and Clinical Models*. H. J. Day, B. A. Molony, E. E. Nishizawa, and R. H. Rynbrandt, editors. Plenum Publishing Corp., New York. 7-30.
  18. Haudenschild, C. C., and S. M. Schwartz. 1979. Endothelial regeneration. II. Restoration of endothelial continuity. *Lab. Invest.* **41**: 407-418.
  19. Groves, H. M., R. L. Kinlough-Rathbone, M. Richardson, S. Moore, and J. F. Mustard. 1979. Platelet interaction with damaged rabbit aorta. *Lab. Invest.* **40**: 194-200.
  20. Baumgartner, H. R., M. B. Stemerman, and T. H. Spaet. 1971. Adhesion of blood platelets to subendothelial surface: distinct from adhesion to collagen. *Experientia (Basel)*. **27**: 283-285.
  21. Minick, C. R., M. B. Stemerman, and W. Insull, Jr. 1979. Role of endothelium and hypercholesterolemia in intimal thickening and lipid accumulation. *Am. J. Pathol.* **95**: 131-158.
  22. Baenziger, N. J., M. J. Dillender, and P. W. Majerus. 1977. Cultured human skin fibroblasts and arterial cells produce a labile platelet-inhibiting prostaglandin. *Biochem. Biophys. Res. Commun.* **78**: 294-301.
  23. Czervionke, R. L., J. B. Smith, J. C. Hoak, G. L. Fry, and D. L. Haycraft. 1979. Use of a radioimmunoassay to study thrombin-induced release of PGI<sub>2</sub> from cultured endothelium. *Thromb. Res.* **14**: 781-786.
  24. Zar, J. H. 1974. *Biostatistical Analysis*. Prentice Hall, Inc., Englewood Cliffs, N. J. 130-148, 236-248.
  25. Bruning, J. L., and B. L. Kintz. 1977. *Computational Handbook of Statistics*. Scott, Foresman, and Company, Ill., 2nd Edition, 116-119.
  26. Pace-Asciak, C. R., M. C. Carrara, G. Rangaraj, and K. C. Nicolaou. 1978. Enhanced formation of PGI<sub>2</sub>, a potent hypotensive substance, by aortic rings and homogenates of the spontaneously hypertensive rat. *Prostaglandins*. **15**: 1005-1013.
  27. Clyman, R. I., F. Mauray, M. A. Koerper, F. Wiemer, M. A. Heymann, and A. M. Rudolph. 1978. Formation of prostacyclin (PGI<sub>2</sub>) by the ductus arteriosus of fetal lambs at different stages of gestation. *Prostaglandins*. **16**: 633-642.
  28. Spaet, T. H., M. B. Stemerman, F. J. Veith, and I. Lejnieks. 1975. Intimal injury and regrowth in the rabbit aorta: medial smooth muscle cells as a source of neointima. *Circ. Res.* **36**: 58-70.
  29. Stemerman, M. B., T. H. Spaet, F. Pitlick, J. Cintron, I. Lejnieks, and M. L. Tiell. 1977. Intimal healing. The pattern of re-endothelialization and intimal thickening. *Am. J. Pathol.* **87**: 125-142.
  30. Tansik, R. L., D. H. Namm, and H. L. White. 1978. Synthesis of prostaglandin 6-keto F<sub>1α</sub> by cultured aortic smooth muscle cells and stimulation of its formation in a coupled system with platelet lysates. *Prostaglandins*. **15**: 399-409.
  31. Moncada, S., A. G. Herman, E. A. Higgs, and J. R. Vane. 1977. Differential formation of prostacyclin (PGX or PGI<sub>2</sub>) by layers of the arterial wall. An explanation for the anti-thrombotic properties of vascular endothelium. *Thromb. Res.* **11**: 323-344.
  32. Higgs, E. A., S. Moncada, and J. R. Vane. 1978. Effect of prostacyclin (PGI<sub>2</sub>) on platelet adhesion to rabbit arterial subendothelium. *Prostaglandins*. **16**: 17-22.
  33. Weiss, H. J., and V. T. Turitto. 1979. Prostacyclin (Prostaglandin I<sub>2</sub>, PGI<sub>2</sub>) inhibits platelet adhesion and thrombus formation on subendothelium. *Blood*. **53**: 244-250.
  34. Fry, G. L., R. L. Czervionke, J. C. Hoak, J. B. Smith, and D. L. Haycraft. 1980. Platelet adherence to cultured vascular cells: influences of prostacyclin (PGI<sub>2</sub>). *Blood*. **55**: 271-275.
  35. Kelton, J. G., J. Hirsch, C. J. Carter, and W. R. Buchanan. 1978. Thrombogenic effect of high dose aspirin in rabbits. Relationship to inhibition of vessel wall synthesis of Prostaglandin I<sub>2</sub> like activity. *J. Clin. Invest.* **62**: 892-895.
  36. Cazenave, J. P., E. Dejana, R. Kinlough-Rathbone, M. A. Packham, and J. F. Mustard. 1979. Platelet interactions with the endothelium and the subendothelium: the role of thrombin and prostacyclin. *Haemostasis*. **8**: 183-192.
  37. Dejana, E., J. P. Cazenave, H. M. Groves, R. L. Kinlough-Rathbone, M. Richardson, M. A. Packham, and J. F. Mustard. 1980. The effect of aspirin inhibition of PGI<sub>2</sub> production on platelet adherence to normal and damaged rabbit aortae. *Thromb. Res.* **17**: 453-464.