

Mitigation and Monitoring of Structural Distress due to Mine Subsidence

Enrique BAZÁN-ZURITA*, **Juan J. GUTIERREZ**

Paul C. Rizzo, Associates
500 Penn Center Blvd. Suite 100, Pittsburgh, PA 15235, USA
enrique.bazanz@rizzoassoc.com, juan.gutierrez@rizzoassoc.com

Sittipong JARERNPRASERT, **Norma C. BAZÁN-ARIAS**

DiGioia Gray & Associates
570 Beatty Road, Monroeville, PA 15146, USA
sittipong@digioiagray.com, cathy@digioiagray.com

ABSTRACT

The prevalent coal mining technique in the United States and other countries is called long wall mining and eventually removes entirely coal seams over extended areas. The removal causes subsidence settlement and horizontal displacements of several feet above the mined seam. Structures located at the surface of affected areas are subjected to differential foundation displacements that can induce stresses beyond the capacity of structural members. It is desirable to preserve the integrity of affected structures not only to avoid costly repairs or replacements but also because they house electrical and industrial equipment that must remain operational. This paper first describes a recent development in the prediction of ground displacements, rotations and curvatures caused by mine subsidence. Then we present the concepts, analyses and design of structural measures for mitigating the anticipated effects of mine subsidence and to alleviate any observed distress during the event.

Keywords: *mitigation, monitoring, mine subsidence, soil-structure interaction.*

1 INTRODUCTION

Longwall mining, where large rectangular blocks of coal are extracted in a single continuous operation is currently the prevalent mining technique. Generally each defined block of coal, or panel, is created by driving a set of headings some distance into the panel. These roadways are then joined to form the longwall face. As the coal is cut and extracted, the longwall face is temporarily supported by hydraulic supports. Upon advancement of the mining face, the immediate roof above the coal is allowed to collapse behind the line of supports creating planned subsidence.

Subsidence is a time-dependent deformation of the ground surface resulting from readjustment of the overburden above a mine. Vertical components of movement are usually the largest, but horizontal movements and the resulting strains and displacements also can cause surface damage. Some movements take place during mining and some after, depending on the type and extent of mining, the thickness and character of the overburden and the mine floor, and other details of the site. With total extraction, subsidence is essentially contemporaneous with the advance of

the ground movement are a slow travelling wave that accompanies the advance of the mine face. The estimation of subsidence movements is governed by the composition, strength and deformability of the overburden strata, the dimensions of the mined-out area, the thickness of the overburden, the degree of caving, the compressibility of the caved material and other factors.

Obviously, it is highly desirable to minimize structural and non-structural damage induced by mine subsidence. In addition, despite of the significant disturbance produced by subsidence, some critical facilities need to remain operational during the subsidence event. In this paper we first present a model to estimate ground movement before planned mining. Then, we describe a soil-structure interaction procedure to assess the impact of the movements on affected structures and foundations. Finally, we propose measures that can be adopted to mitigate structural distress, as well as their modeling and monitoring.

2 ESTIMATION GROUND MOVEMENTS DUE TO MINE SUBSIDENCE

2.1 Analytical Modeling of Mine Subsidence

One of the authors has developed a three-dimensional model to estimate ground deformations induced by longwall mining subsidence, based on extensive set of data from south-western Pennsylvania [1]. Lateral deformations are handled through analytical derivations and represent conditions of flat terrain. Geometric parameters considered in the subsidence model are given in Figure 1. The overburden or mining depth, H , is the vertical distance between the extracted seam and the ground surface. The width, W , is the short horizontal dimension of longwall panels. The extraction thickness is M . Maximum subsidence, S^* , is the magnitude of maximum vertical surface deformation. The angle between the horizontal and the line connecting the extraction edge and the surface at zero vertical deformation is called the angle of influence, denoted by β .

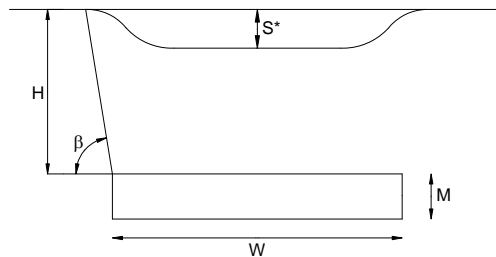

Figure 1. Definition of main parameters in transversal view of mine panel.

S^*/M , known as the subsidence factor, is the ratio of vertical deformation with respect to the thickness of extraction. As an example we have set the extraction thickness as 2.3 m, and the average S^*/M equal to 0.67, resulting in a maximum vertical deformation, S^* , equal to 1.5 m. The overburden height, H , was assumed to be 230 m, and the angle of influence, β , equal to 68 degrees. It was also assumed, as is typical, that the width of extraction is very large. This condition creates a flat central zone that settles by the magnitude of S^* , as shown in Figure 1. The subsidence function is:

$$\frac{S}{S^*} = \frac{1}{\left[1 + e^{-\left(a_1 + a_2 \frac{x}{H}\right)}\right]^{a_3} \left[1 + e^{-\left(a_4 + a_5 \frac{z}{H}\right)}\right]^{a_6}} \quad (1)$$

The origin of coordinates is at the left end of the projection of the mining face in the advance direction, as shown in Figure 2. Typical model parameters are $a_1 = -2.79$, $a_2 = 11.6$, $a_3 = 1.24$, $a_4 = -1.94$, $a_5 = 5.99$, $a_6 = 1.23$ [1], and the model is used for x to $W/2$. The other half is mirrored in

the case of a symmetrical profile. The instant deformation of the trough front at any given point in time is shown in Figure 3 for a panel width of 380 m.

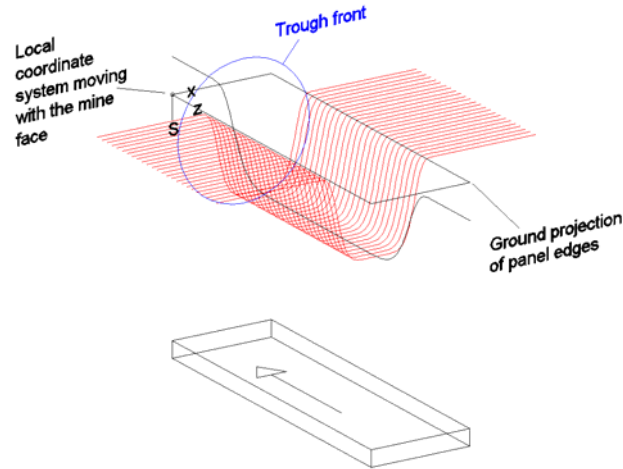

Figure 2. Definition of coordinate system.

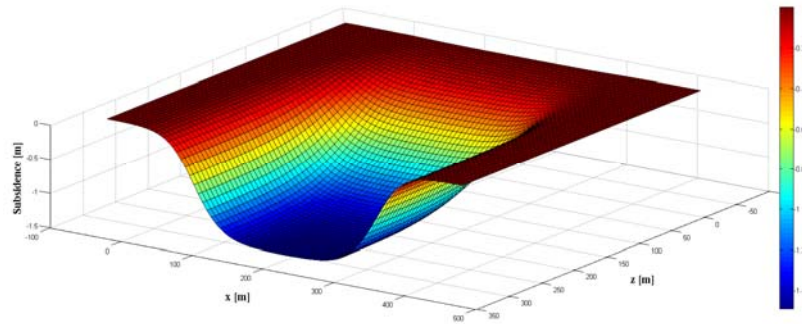

Figure 3. Subsidence trough obtained with the present model.

2.2 Temporal distribution of subsidence

The temporal effects of subsidence can be incorporated by expressing the longitudinal direction in terms of time. This can be done assuming that the rate of advance, v , of the mine face is constant. A typical rate of advance in current practice is 17 m/day. The longitudinal coordinate, z , is thus expressed as $z = vt$. This produces a model of subsidence that is a function of time, t , in days, and transversal position, x , in meters:

$$\frac{S}{S^*} = \frac{1}{\left[1 + e^{-\left(-2.79 + 11.6 \frac{x}{H}\right)}\right]^{1.24} \left[1 + e^{-\left(-1.94 + 102 \frac{t}{H}\right)}\right]^{1.23}} \quad (2)$$

2.3 Estimation of longitudinal deformations in the central trough

Deformation indices that can be derived analytically from the three dimensional model are:

- Slope, calculated as the first derivative of subsidence.
- Horizontal deformation, approximated by a linear correlation to slope in the case of flat terrain.
- Curvature, approximated by the second derivative of subsidence.
- Horizontal strain, calculated as the first derivative of horizontal deformation.

One scenario of interest is a large structure located in the center of the path to be followed by the advancing panel. The history of boundary deformations for the structure can be established with the subsidence model. For the model in equation (1), the following parts can be defined:

$$C_x = \frac{S^*}{\left[1 + e^{-\left(a_1 + a_2 \frac{x}{H}\right)}\right]^{a_3}} \quad (3)$$

$$S_z = \frac{1}{\left[1 + e^{-\left(a_4 + a_5 \frac{z}{H}\right)}\right]^{a_6}} \quad (4)$$

Since we are also interested in longitudinal displacements, we need the first derivative of (4) in order to calculate the longitudinal slope and displacements in the direction of mining:

$$S'_z = \frac{a_5 a_6}{H} \frac{e^{-\left(a_4 + a_5 \frac{z}{H}\right)}}{\left[1 + e^{-\left(a_4 + a_5 \frac{z}{H}\right)}\right]^{a_6 + 1}} \quad (4)$$

Using equations (3) and (5), we calculate the longitudinal slope:

$$\text{Slope}_z = \frac{\partial S}{\partial z} = C_x S'_z \quad (5)$$

The second derivative of S_z enables us to estimate curvature:

$$\text{Curvature}_z = \frac{\partial^2 S}{\partial z^2} = C_x S''_z \quad (6)$$

The distribution of longitudinal slope is depicted in Figure 4. Horizontal deformations can be estimated by linear correlation to the slope assuming flat terrain [1]. With reference to Figure 1, the factor $B_f = B(H/\tan\beta)$, where B is a constant and $H/\tan\beta$ is the radius of influence, can be used for this purpose [2]. For $B = 0.15$, the horizontal deformation and horizontal strain in the longitudinal direction are:

$$H.D._z = -B_f \frac{\partial S}{\partial z} = -(C_x)(B)(H/\tan\beta)S'_z \quad (7)$$

$$H.S._z = \frac{\partial(H.D._z)}{\partial z} = -(C_x)(B)(H/\tan\beta)S''_z \quad (8)$$

The longitudinal horizontal deformation is depicted in Figure 5. Longitudinal curvature and longitudinal horizontal are displayed in Figures 6 and 7.

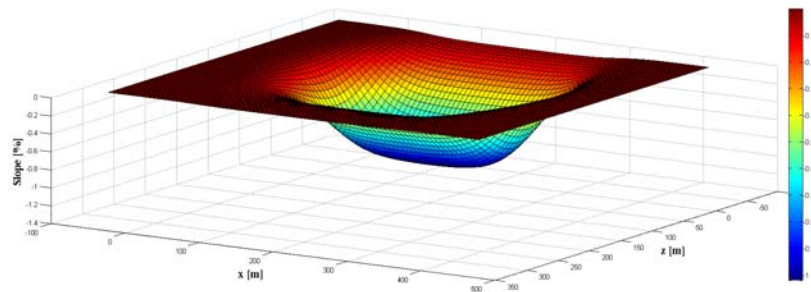

Figure 4. Longitudinal (z) slope distribution of subsidence trough obtained with new model.

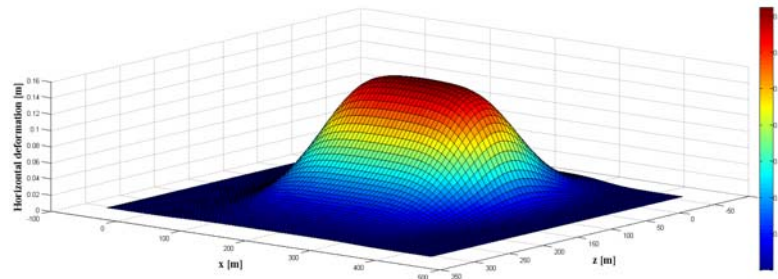

Figure 5. Longitudinal (z) horizontal deformation distribution of subsidence trough obtained with new model.

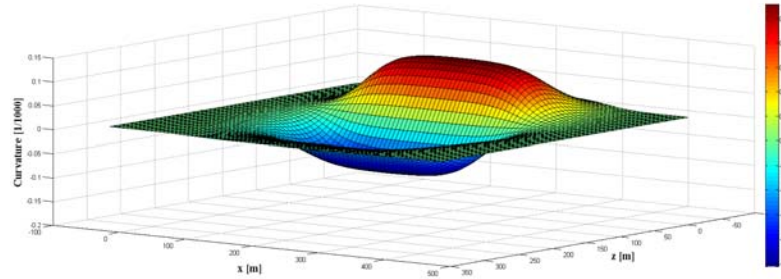

Figure 6. Longitudinal (z) curvature distribution of subsidence trough obtained with new model.

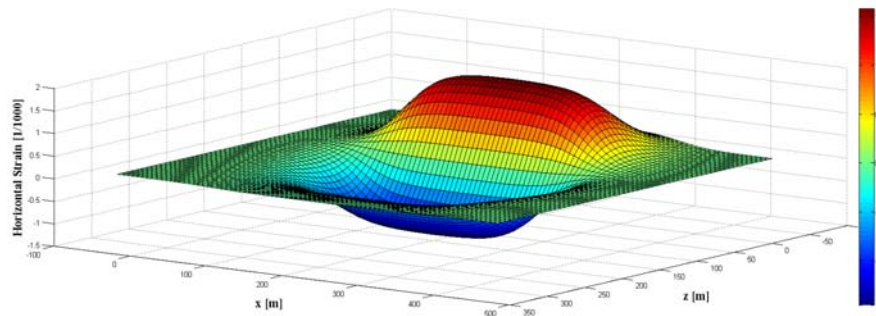

Figure 7. Longitudinal (z) horizontal strain distribution of subsidence trough obtained with new model.

3 EFFECTS OF MINE SUBSIDENCE ON STRUCTURES

3.1 Impact of ground displacements on structures

As illustrated in Figure 8, mine subsidence can originate uneven ground settlements and horizontal displacements of several feet. The foundations of buildings on the affected areas tend to move along with the ground exhibiting different levels of distortion as the mining wave progresses. This, in turn, can induce significant structural distress. The severity of damage is commensurate with the magnitude of the displacements and with the ability of the structures to preclude or to accommodate strains. Some constructions, as those supported on single columns or rugged components resting on stiff foundations, are practically unaffected because they move as rigid bodies. On the other end, very flexible structures have sufficient deformation capability to tolerate relatively large deformations without significant strains. Most buildings fall among these two extreme conditions and are able to accommodate the strains generated by design loads, but not the distortions and stresses generated by subsidence. Unreinforced masonry buildings are particularly sensitive. Long structures with multiple supports, underground wiring, rigid busses, and taut overhead cables are also very sensitive to the relative motion of their supporting points.

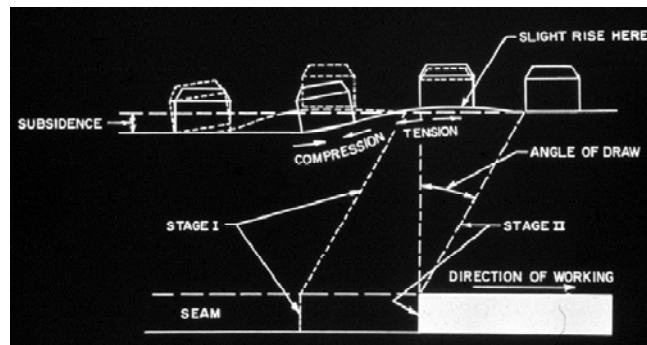

Figure 8. Typical surface motion due to longwall mine subsidence [3].

The following effects of mine subsidence are relevant for evaluation of structural distress:

- relative vertical displacements,
- relative horizontal displacements,
- tilting, and
- ground curvature.

4 STRUCTURAL ASSESSMENTS

Using finite element codes, it is straightforward to develop an elastic model of any structure affected by anticipated mine subsidence. The model can represent deformable foundations with translational and rotational springs, called soil structure interaction (SSI) springs, such as those shown in Figure 9, using formulas provided by Gazetas [4]. For drilled shaft foundations, SSI springs can be estimated with the help of recent computer codes such as MFAD [5]. Even though mine subsidence is a time varying event, the movements are too slow to generate any dynamic forces, i.e., no forces associated with accelerations or velocities need to be considered. Thus, the analysis of the effects of planned mine subsidence can be conducted through the following steps:

- use the previously described model to predict free field ground displacements and rotations due to subsidence;
- calculate stiffness of SSI springs that represent the foundations of affected structures;
- impose the appropriate free displacements on the SSI springs alone to calculate “SSI forces”;
- develop a finite element model of each affected structure including their SSI springs; and
- apply the SSI forces at the foundation locations of each finite element model and calculate the stresses on structural member and foundations.

The results of the stress analyses reveal areas of the structures that will be subject to the most damaging effects. Deformed structural configurations, such as the one depicted in Figure 10, indicate what non-rigid body displacements can be of major concerns. Figure 9 shows that the SSI spring parameters depend on the shear modulus, G , of the bearing soil. It must be kept in mind that G decreases for increasing shear strains. Thus, ground strains have also to be estimated with the subsidence model to select a representative value of G .

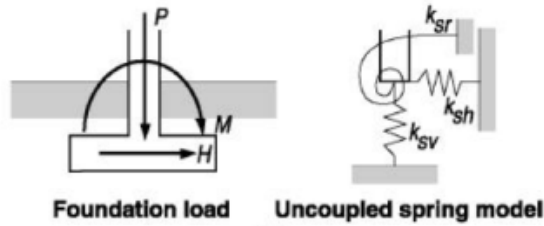

Figure 9. Spring model of foundation stiffness

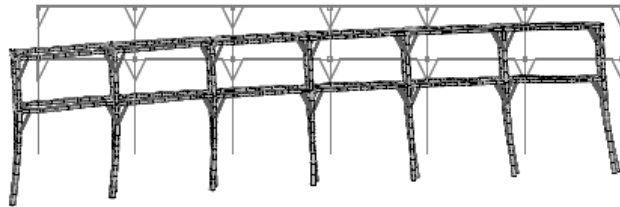

Figure 10. Multi-span frame subjected to estimated support displacements.

5 MITIGATING MEASURES

Measures to mitigate the impact of subsidence attempt to minimize strains on the affected structures by either promoting rigid body movements or by providing additional flexibility to accommodate the movements. In general, the mitigating measures fall into the following categories:

- stiffening of panels and foundations to promote rigid body structural movements;
- loosening of connections between structural members and at foundation locations to allow some extent of mechanism movements;
- tying members and foundations to provide temporary resistance to tensile and shear deformations; and
- excavating around foundations to make them more flexible and to promote ground cracks away from them.

The purpose of these measures is to reduce surface ground strains at structure locations, compensate for subsidence induced deformations in the structures, and reinforce structures to tolerate anticipated deformations.

Figure 11 illustrates the use of cables to tie four independent foundations of the same structure, thus limiting relative horizontal displacements. We use tension-only members to represent the cables and include them in the soil-structure interaction model, thus estimating the forces that they must resist. Since the cables resist only tensile forces, if the horizontal movements induce compressive stresses between foundations, we consider that they will be resisted by the ground.



Figure 11. Four separate foundations tied.

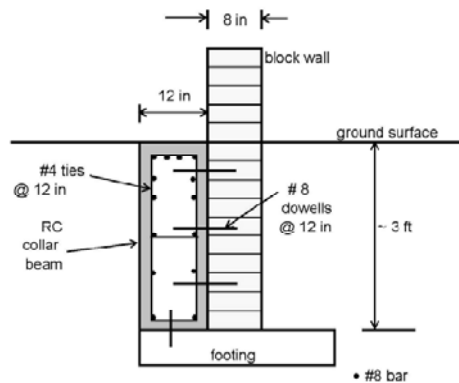

Figure 12. Stiffening and reinforcement of the strip footing of a masonry room.

Concrete slab foundations might be susceptible to propagation of existing cracks or formation of new cracks due to horizontal ground strains including propagation of ground cracks. A mitigating measure consists in wrapping tightly the foundations with cables to resist horizontal tensile stresses. An additional example of foundation stiffening is shown in Figure 12, where a strip footing supporting a masonry room is embraced by a stiff reinforced concrete beam, causing the room to move essentially as a rigid box. Figure 13 illustrates the effectiveness of this measure and also leaves the excavation around the foundation drives ground cracks away from the foundation.

On the other hand, some stiff elements, such as a rigid bus in electrical substations, can be replaced by a flexible counterpart to minimize its damage and to allow connected structures to move more independently. Steel structures can be temporarily modified to help them to accommodate relative displacements by loosening the bolts of connections at foundation locations, as illustrated in Figure 13. This figure shows that this loosening can result in appreciable displacements and rotations during the subsidence event, but the original position is normally restored when the mine front completely passes over the site. Rigid bolted connections between two steel members (say a beam and a column) can be also loosened to allow some extend of relative rotation at the joint. In these, it is prudent to add some mechanism to restrains excessive rotations, such as cables that being initially in slack condition will become taut under greater displacement, as illustrated in Figure 14. The release of displacements and rotations can be represented in the structural models by sliding supports or by hinges, respectively.



Figure 13. Reinforcement of footing of a masonry room.



Figure 14. Loosening of the bolts of the connection of the structure to a footing.

6 MONITORING

Even though predictions of total subsidence displacements are quite accurate, they do not reflect local deviations from average values due to the randomness of the subsurface materials, ground cracking, local sinking and other effects. Thus, a plan to monitor movements at critical locations in the structural and foundation elements must be devised and implemented. The first step is to establish a baseline by surveying selected points of the foundations and structures before mining. Subsequent surveying during the subsidence event allows determination of relative displacements between different points. Monitoring also includes visual examination and measurement of movements at the joints that have been loosened, and at the base of slab foundations. In addition, manometers should be installed to measure tension in tying cables.

A very important result of monitoring is the verification of the adequacy of the adopted mitigating measures. For instance, by recording relative displacements, tilting, extend of openings in loosened connections, ground and concrete cracking. It is frequently necessary to increase stiffening measures, to add additional deformability, to stretch cables to maintain tying forces, or to release cables to prevent tensile failures.

7 CONCLUDING REMARKS

Long wall coal mining causes significant settlement and horizontal displacements above the mined seam, in particular at the ground surface. Structures located on affected areas are subjected to

differential foundation displacements that can induce stresses beyond the capacity of structural members. Settlements easily reach several feet. Estimation of such displacements, structural assessment of their effects, design of mitigating measures and monitoring during the subsidence event are required to minimize structural and nonstructural damage. The analytical three-dimensional model described in this paper predicts subsidence induced displacements, rotations and curvatures with sufficient accuracy to assess the structural integrity of affected facilities affected. We also propose in this paper the steps to develop static soil-structure interaction models for estimating stresses due to planned mining. This allows accurate assessments of the structural integrity of potentially affected edifications.

Potential damage can be significantly decreased by devising, implementing and monitoring mitigation actions that reduce surface ground strains, compensate for induced deformations in the structures, and reinforce components to tolerate anticipated deformations. Depending on the materials, geometry, and foundation layout of particular structures, the impact of subsidence can be alleviated by stiffening of panels and foundations to promote rigid body movements, and/or by softening connections to facilitate limited mechanism type of movements. This was successfully performed in an electrical substation in western Pennsylvania, where the settlement reached 5 feet. Details are provided in Bazán et. al. [6].

8 REFERENCES

- [1] Gutierrez, J.J., 2010. Estimating Highway Subsidence due to Longwall Mining. PhD Dissertation, Department of Civil and Environmental Engineering, University of Pittsburgh.
- [2] Agioutantis, Z., and M. Karmis. 2009. *Surface Deformation Prediction System for Windows version 6.0: Quick reference guide and working examples*. Virginia Polytechnic and State University.
- [3] Gray, RE, and Bruhn, RW, 1984. Coal Mine Subsidence – Eastern United States, in Man Induced Land Subsidence, Reviews in Engineering Geology VI, Ed., T. Holzer, The Geological Society of America, Boulder, Co
- [4] Gazetas, G., 1991. Formulas and Charts for Impedances of Surface and Embedded Foundations, Journal of Geotechnical Engineering, Vol. 117. No. 9, ASCE.
- [5] EPRI, Palo Alto, CA and DiGioia, Gray & Associates, LLC: 2010. *MFAD 5.1: User Guide for MFAD 5.1 (Moment Foundation Analysis & Design)*. Product ID #: 1019957.
- [6] Bazán, E., P. Glogowski, R. Fandray, S. Jarernprasert and P. Cass. 2011. *Mitigation and Monitoring of Structural Distress in Electrical Substations Due to Mine Subsidence 5th International Conference on Structural Health Monitoring of Intelligent Infrastructure (SHMII-5), Cancún, México.*