

## REPLICATION TECHNIQUES FOR DRY AND WET BIOLOGICAL SURFACES

Bo Forslind\*

Experimental Dermatology Research Group, Department of Medical Biochemistry and Biophysics,  
Karolinska Institutet, Stockholm, Sweden

(Received for publication April 23, 1998 and in revised form November 16, 1998)

### Abstract

This overview of replication techniques for light and electron microscopic applications gives a generalized background to past and current approaches. The silicone mould replication techniques, which have the great advantage of being applicable to dry as well as wet surfaces, have proven to be the most successful so far. They are discussed in some detail and a number of practical hints for a successful procedure are given. These techniques have a potential of use in material, biological and even in archaeological sciences, although so far such applications have not attracted much attention.

**Key Words:** Replication, light microscopy, electron microscopy, biology, material science, archaeological science.

### Introduction

Replication is a means of depicting the topography of an object, such as a tissue surface. Even before the introduction of the scanning electron microscope (SEM) replication techniques had been used for light and transmission electron microscopy (TEM) [2, 11]. The TEM requires extremely thin, and essentially electron translucent objects and this requirement could be met by a multiple stage preparation procedure. An essential drawback with the techniques was that they were destructive in general, meaning that the bulk of material under the surface to be replicated had to be dissolved to free the replicating material from the "original". In general, the applicability was restricted to material that could be obtained as biopsies and it was therefore impossible to follow changes that occurred at a particular site of a tissue.

In principle the replica of a surface can be a negative (or direct) one alternatively a positive, and consequently a two-step replica. Ideally in the first step the replication material should have an initial fluid character, so as to fill out the finest details of the surface to be depicted. In the second step it should cure to form a coherent sheet that can be loosened from the surface to be replicated without leaving any material deposited on the replicated surface or extracting any material from the surface. A third feature of importance in biological applications is that the replicating material should be as applicable on wet as on dry surfaces [13]. It turns out that materials developed for replication in dental work have the required properties, adhering tightly to the surface whether dry or wet, easy to release from the surface and fully coherent after isolation from the replicated surface. The dental silicone plastics have proven to give a detailed recording of surface topography allowing a final analysis in the SEM at magnifications as high as 5000 X. After a short overview of old replication methods, an outline will be given for a two-step surface replication technique using silicone plastics for the primary replication and plastic polymers for the second, positive replica. The reader is provided with an approach that has proved to be highly successful but I do not aim to provide a complete catalogue of materials and references. The emphasis is on simple and fast measures

\*Address for correspondence:

Bo Forslind

Experimental Dermatology Research Group  
Department of Medical Biochemistry and Biophysics  
Karolinska Institutet, S-171 77 Stockholm, Sweden

Telephone number: +46-8-728 6796

FAX number: +46-8-326505

E-mail: [bosse@mango.mef.ki.se](mailto:bosse@mango.mef.ki.se)

or [Bo.Forslind@mbb.ki.se](mailto:Bo.Forslind@mbb.ki.se)

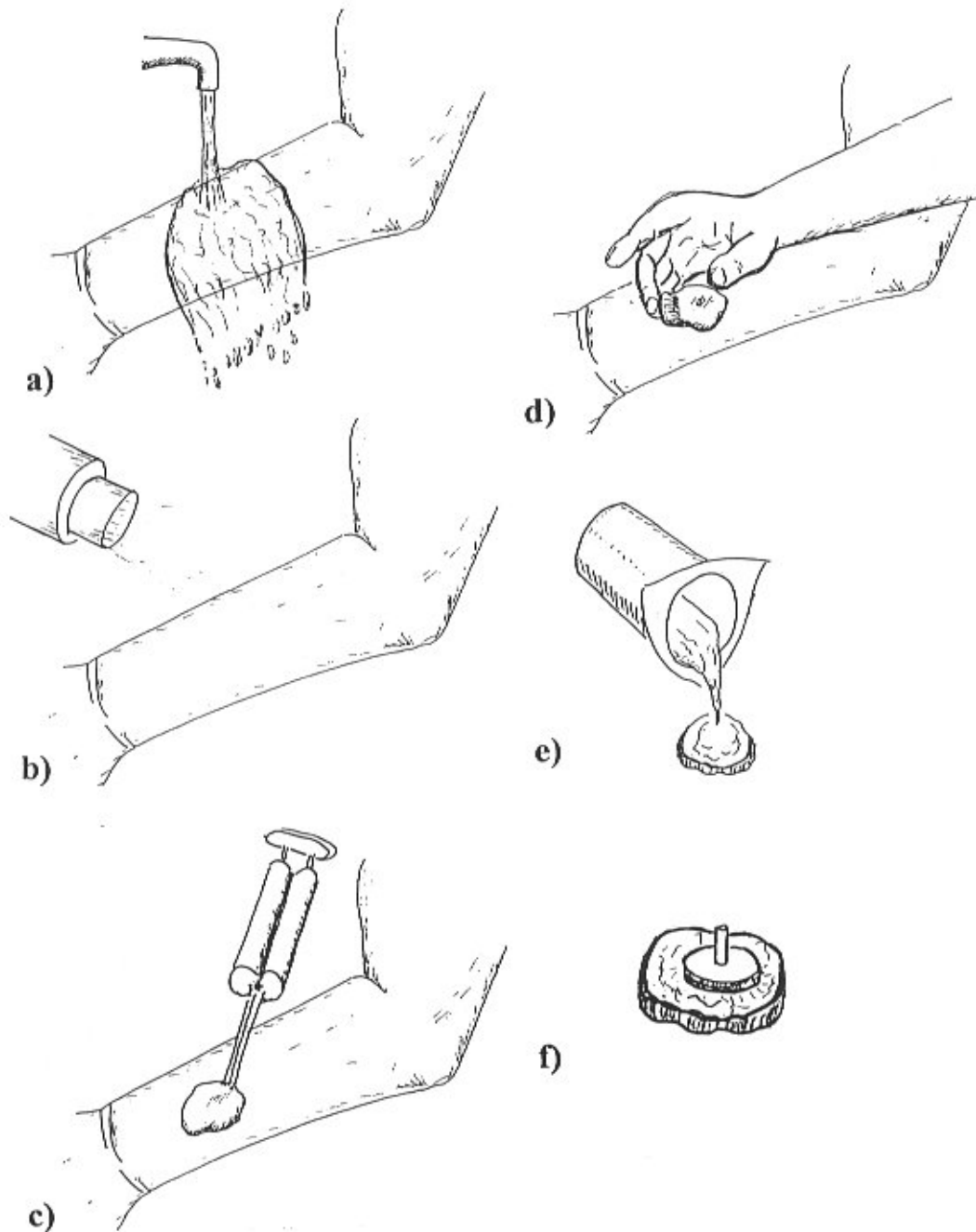

**Figure 1.** The preparation of an imprint from a dry or wet surface is here depicted as sampling a human skin surface. The skin surface is first rinsed under tap water (a), and air dried (b). The mixture of silicon polymer and catalyst are then applied (c) to the designated area (here via a dual application vessel). After approx. 3 minutes of curing the replica can be peeled off (d) and filled with appropriate resin (e) that cures to yield a hard positive replica, which subsequently is sputter coated with carbon or a metal to obtain a conductive surface, thus avoiding charged spots during microscopy. It is often a practical measure to secure the positive replica on the stub as it cures (f).

suitable in the field or in the consultation office [6]. I would like to underline that although our experience is in dermatological applications [3], I see no restriction for using

the methods in any imagined application. George Bernhard Shaw truly stated: *The golden rule is that there are no golden rules.*

### **Replication of Dry, Solid Surfaces: Carbon and Metal/Carbon Replication**

#### **The method**

Since it was developed for transmission electron microscopy (TEM) the carbon or metal/carbon technique provides a replica that is electron transparent enough to be used in the TEM. Since the crucial steps of preparation are performed in high vacuum it is mandatory that the specimen is fully dehydrated before the actual replication procedure. For biological specimens this can be achieved either by conventional chemical fixation or by cryo-methods including freeze-substitution and critical point drying.

The replication requires seven steps including an initial cleaning of the surface to be replicated by an appropriate method, e.g., ultrasonication, organic solvents, water etc. The subsequently dried object is subjected to the following six steps:

1. The clean surface is covered with a thin carbon or metal (Cr, Pd/Pt, Pt, Au) film at an angle (often 6-10°) by evaporation in vacuum.

2. The evaporated film is stabilized by application of a thin plastic film, e.g., Formvar.

3. The object is either removed mechanically or by chemical dissolution. The latter is preferred as the former often disrupts the replica.

4. The (negative) replica is stabilized by a thick layer of carbon and given a thin metal coating evaporated onto the replica in vacuum.

5. The plastic film is removed by the appropriate solvent for the plastic in question.

6. The positive carbon/metal replica is now transferred to a conventional electron microscopic grid and viewed in the TEM.

The resolution obtainable with this technique is satisfactory at least down to 20 nm (200 Å) on metal surfaces. The resolution is somewhat less for biological specimens and very much dependent on the nature of the specimen surface and the preparation.

It can be noted that a similar process, omitting the plastic intermediate stage, is used in the production of freeze-fracture replication which has been successfully used in membrane research.

#### **Sources of artefacts**

Obviously one has to be aware of the possible undesirable artefacts that can be introduced in this part of the preparation protocol. Detailed analysis of sources to artefacts are found in all books on electron microscopic preparation [e.g., reference 4]. All fixation and drying procedures induce various degrees of surface structure artefacts due to linear or volume changes, shrinkage, etc.

One of the important factors that determine the reso-

lution that can be obtained is related to the granularity of the replication film. This in turn depends on the metal chosen for producing the surface film, the heating of the metal source and the manner in which the object temperature is controlled during metal deposition [9, 10].

#### **Applicability**

The loss of the original sample and the fragmentation of the replica on transferring to the electron microscopic grid represent the main drawbacks of the technique, although virtually impossible to avoid. The technique is generally most advantageous when high-resolution replication is required, i.e. when sampling is made from minute areas. Consequently this is preferentially a TEM technique.

### **The Plastic Impression Technique**

#### **The method**

Replicas for light microscopy have been made from plastic compositions even before the introduction of the SEM. The plastic impression technique requires a clean and dry area for the replication [1, 8] and in the beginning, interest was focused on low resolution details of the object, e.g., in biological contexts the hairless skin where the cutaneous patterns of furrows form patterns characteristic of a certain area of the integument.

Simply spreading the liquid plastic over the area to be sampled and allowing it to cure before mechanical removal provides a detailed negative imprint. Household glues based on plastics in organic solvents that evaporate quickly can produce acceptable results when only low resolution is required.

When the plastic has cured and been removed from the object surface it is sputter-coated with, e.g., gold before introduction into the SEM.

#### **Sources of artefacts**

The preparation of the skin surface to be replicated includes measures such as cleaning, degreasing with organic solvents (in replication of animal skin also shaving) etc., which are likely to produce artefactual changes of fine surface structures. Gross features of the area replicated, e.g., in skin the patterns of furrows and wrinkles, reproduce well even at low magnifications, e.g., more than 10 times.

#### **Degree of correlation to other methods**

The plastic impression technique is a one-step method generally very simple to perform and yielding a negative imprint of the surface. There is some loss of loose surface material of the object and also loss of fine details at the high magnifications attainable in the SEM.

## The Silicone Elastomer Replication Technique: a Two-Step Method

### The method

**Step 1: the negative replica.** Silicone-elastomer replication has its basis in products developed for use in clinical dentistry [5, 17]. One can discern five main requirements on the plastic used for producing a negative mould:

1. The silicone plastic should have a low viscosity to be able to adhere closely even to the fine details of the surface.

2. The silicone plastic should adhere well even to wet surfaces.

3. After a fast and complete polymerization, it should be released from the original specimen without leaving any material behind.

4. The silicone plastic should possess an elastic memory to allow a complete return to the original status even when withdrawn from undercuts.

5. The polymerization process of the silicone plastic should not involve an exothermic reaction, which may change the surface properties of the object, along with the discomfort of the subject if used *in vivo*.

**Step 2: the positive replica.** To produce a faithful positive replica the plastic used should cure at room temperature with as little release of heat as possible to prevent deformation of the negative mould.

Our main experience comes from the use of moulds made from Provil-L® (Bayer Dental D-5090, Leverkusen, Germany), which is characterized as a low viscosity, type I silicone meeting the requirements of ISO 4823, type (e) 3, category A (adhesion induced polymerization). The silicone plastic is thoroughly mixed with an equal volume of catalyst (curer) and immediately applied to the surface to be replicated (Fig. 1). It is then allowed to set for about 3 minutes before gentle removal from the (skin) surface. The negative replica is subsequently covered with an Araldite® plastic (CIBA-Geigy, Basel, Switzerland) which cures within 3-5 hours depending on the volume applied. Alternatively we have used a methacrylate (Sigma, St. Louis, MO) designed for whole-mount embedding of e.g., insects, which has longer curing time. The London Resin (LR) White acrylic resin (hard) (London Resin Co., Reading, Berkshire, UK) using benzoyl peroxide as an initiator has proven to be an excellent choice. The surface of the plastic, positive replica is subsequently made conductive by gold or carbon sputtering.

### Sources of artefacts

**The negative mould.** A large negative imprint of a curved object, e.g., the skin of a fingertip surface (i.e., larger than 1x1 cm<sup>2</sup>), tends to bend when loosened from the original surface and this large curvature remains when

the positive replica is made. Due to high total absorption of energy in the electron beam, a *larger-than-the-stub* specimen tends to be unstable in the beam, i.e., be subject to drift during viewing in the SEM. Low voltage analysis (<5kV) is recommended for such objects if they are not cut up into smaller units.

**The positive replica.** Making the positive replica the amount of accelerator may be crucial to the final results. If the curing process proceeds at a rate that is too fast, gas bubbles will tend to accumulate at the replica surface.

### Applicability

As the silicon plastic is free from noxious and allergenic properties it can be applied to almost any biological surface without discomfort to the subject. In our hands it allows a resolution of at least 100 nm but the ultimate achievable resolution should be tested by replication of metal gratitudes. Better than other techniques it discloses undercuts etc. in the surface topography (Fig. 2).

### Recommendations for using the silicone elastomer replication technique

**The negative replica.** A critical stage in making a replication is the mixing of silicone base and catalyst. The two components should be thoroughly mixed but agitation should not be so vigorous as to produce air bubbles. The drawbacks of manual mixing can be virtually eliminated when using a dual vessel ejector (Bayer Cartridge delivery dispensing gun). If one makes a negative replica for SEM care should be taken to cover a surface area that does not exceed the size of the SEM specimen holder (the "stub") to avoid the unnecessary heating that results from having a large specimen surface.

Inspecting the negative replica under a light microscope at approx. 40 X magnification when it has been removed after setting, the replica surface can be checked to ensure that it is free from air bubbles. Such simple measures save much time, work and funding money.

Typically epithelial surface cells may adhere to the negative imprint when it is released from the skin surface. Usually this cell debris can be removed by a jet stream of dry, clean air. Alternatively the negative mould can be rinsed under running, cool tap water and subsequently air-dried in a dust-free environment. To avoid this effect as much as possible a clean epithelial/tissue surface can be obtained by a quick rinse under cool tap water (Fig. 1). After a thorough rinse the surface to be replicated is blotted dry with soft, fluff-free face tissue paper or dust-free cloth to avoid friction that could produce surface artefacts. An improvement of resolution of details by the silicone is sometimes obtained through a quick cool water rinsing which undoubtedly removes water-soluble surface material. Our experience from human stratum corneum stud-

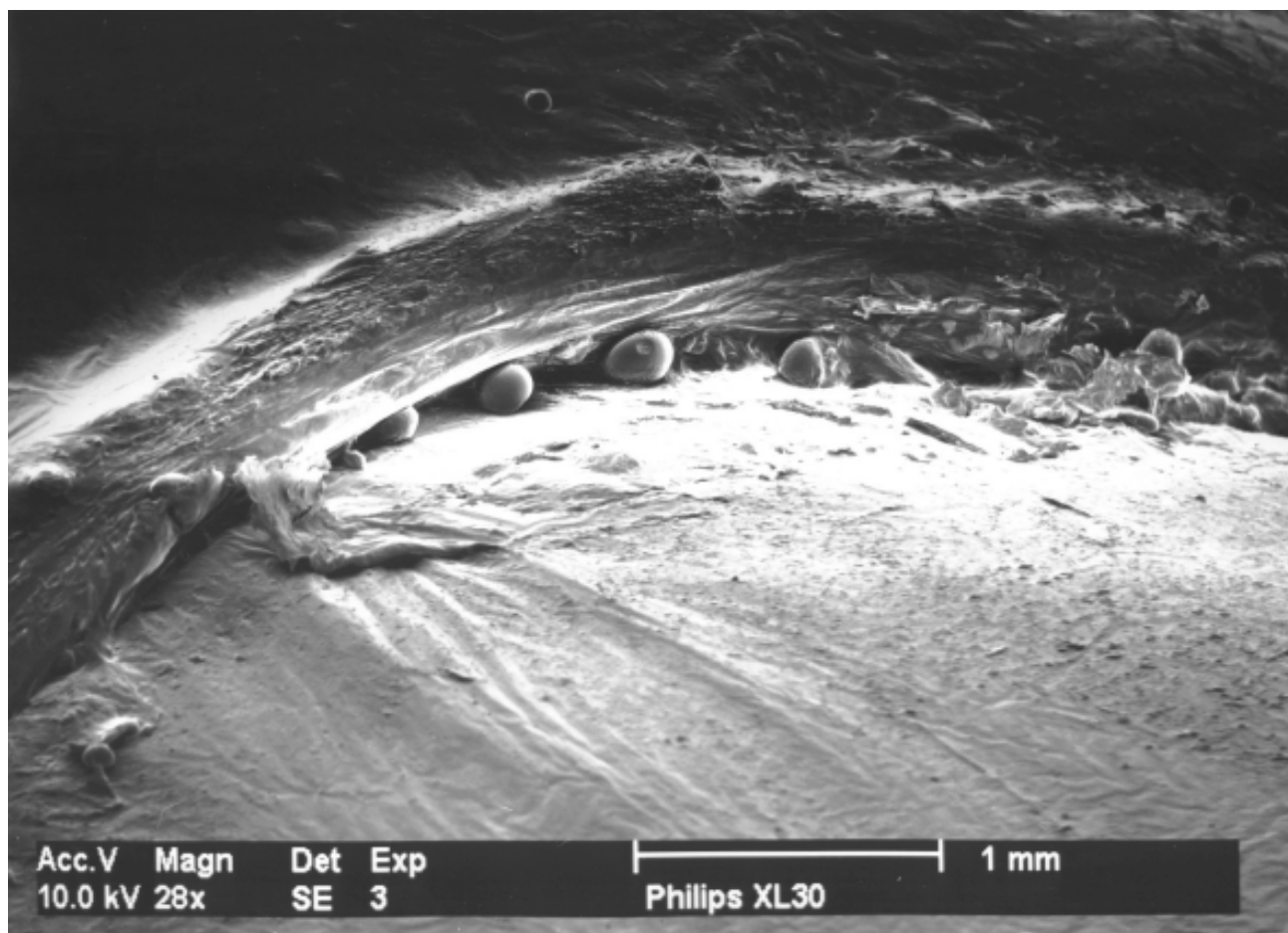

**Figure 2.** Scanning electron microscopic image of a silicon mould replica of the human nail plate emerging from the proximal nail fold. The plastic replica was gold sputtered after curing. Note the details of the underscoring at the opening to the nail fold. Here cuticle cells originating from the epidermal part of the nail fold roof can be seen to be closely adherent to the nail surface (thick arrows) as well as a few bacteria (rounded bodies). In the upper dark part of this image details of the horny layer surface can be seen.

ies suggests that at low magnification (e.g., 40 X) no swelling is apparent from this process. One must however, be aware that rinsing may introduce artefacts in pathologically disturbed skin, e.g., eczema. An alternative measure is then to make two or three impressions from the same surface rather than making the lesion subject to tap water rinse. This will evidently remove loose surface material, and the sequentially obtained moulds can be checked against each other for artefacts.

**The mould.** The negative imprint is not suited for direct study in the SEM. The silicone plastic has a very low melting point (<80°C) and evaporates when hit by the electron beam contaminating the microscope and produces an artefactual image. For light microscopic and photographic observations at low and moderate magnification

(10 X) the negative mould may be used directly. If this is the object, rather than a study in the SEM, large areas can be replicated, e.g., 2x2 cm<sup>2</sup>.

**The positive replica.** The right choice of plastic is crucial in the making of a successful positive replica. In our laboratory we have used Araldite® (Ciba-Geigy) in a 1:1 mixture with accelerator. The manufacturer's advice on mixing proportions for plastic and accelerator should be tested for each batch of plastic as it may vary during ageing of these materials. It is our experience that it is not unusual that the amount of accelerator should be somewhat reduced to get a curing rate that does not produce heat and solvent gas bubbles. However, it is easy to get incomplete curing that results in a sticky surface which deforms on removal from the negative mould. Therefore,

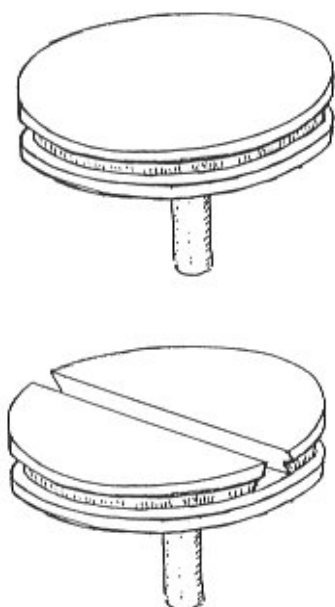

**Figure 3.** Milling a groove with an underscore in the specimen stub secures the plastic replica.

it is recommended that the curing properties be investigated before applying the plastic to the negative moulds.

We have found that a way to reduce the risk of gas bubbles at the interface between the negative mould and the plastic is to moisten the surface of the silicone imprint with the solvent of the plastic (e.g., acetone for Araldite®) immediately before pouring the plastic onto the negative template.

Small gas bubbles at the surface interface mars the images of the replicated object. Therefore, the positive casts should be inspected under a preparation microscope after gold sputtering, for the presence of gas bubbles in the surface. If bubbles are present they usually attain a size that allows them to be seen at moderate magnifications (about 40X).

We have used a hard methacrylate (Sigma) designed for embedding of large objects such as insects, e.g., a beetle as an alternative to Araldite®. This methacrylate, which takes more than 24 hours to cure even in thin sheets, tends to be very brittle. It reproduces the surface details well in our experience.

### Alternative Techniques and General Comments

A selective review of the literature shows that a number of alternative plastics have been used for the positive replica. Here we may mention the report by Pfister and Neukirchner [12] who used a polystyrol granulate dis-

solved in toluol for the positive replica. The non-cured plastic has a syrup-like consistency and to avoid air bubbles in small crevices of the negative replica the authors “moisten” it with the solvent (toluol) before applying the plastic. The curing time of this polystyrol plastic is comparatively long, approximately 24 hours. The authors claim that magnifications up to 5000 X are attainable with this technique.

### Gold sputtering and avoiding charging in large specimens

A plastic positive replica is made from a material that essentially is an insulator. Gold sputtering of the replica surface provides it with a very thin, conductive surface film that distributes charges to ground potential but also contributes as a heat sink. The stub surface should be cleared of the specimen at small point to allow the metal deposited by sputtering to provide a continuous contact between the replica surface and the specimen stub.

When large objects are used it is advantageous if the stub can be moulded into the positive plastic replica, e.g., by making an undercut groove with a milling cutter (Fig. 3). Alternatively a cavity with an undercut in the stub surface can be made using a dental drill. Through these means drift is virtually completely eliminated.

### Present Status of Replication Techniques

Our experience stems from applications in experimental dermatology but since we are dealing with both dry and wet biological surfaces these experiences should have applicability in most other areas. Using replication techniques most areas of the human integument in health have been described [1, 2, 6, 7, 8, 14, 16, 18]. Pathological conditions including lesions of psoriasis [15], superficial actinic porokeratosis as well as more unusual conditions like Gorlin’s syndrome [8] have also been documented. Little, if any functional interpretations of the findings using replication techniques are found in the literature and at least in studies of the skin topographic data collected by replication (and corresponding) techniques on skin and its appendices in general merely have a descriptive character. Industrial applications, e.g., cosmetic industries have since long utilized SEM studies of the effect of cosmetic formulations on the skin surface and the integument appendices, but details of such information have not been publicly available and cannot be scientifically evaluated.

It is obvious that topographical methods of investigating biological tissue surfaces represent an interesting and potentially fruitful area of research. Combination with morphometric systems, image analysis systems or other physical measurement systems [7] will allow quantitative analysis of changes in the surface structures as a result of the progress of a disease, the influence of environmental

factors or, in medical applications, a treatment of a disease. In addition to such applications a more extensive use of the excellent replication materials presently available will no doubt increase our knowledge of the functional dynamics animal and botanical tissue in health and disease.

### Acknowledgement

I am indebted to Ms. Eva Lundevall of the Swedish branch of Phillips Industrial Electronics AB for producing the SEM micrographs.

### References

1. Chinn HD, Dobson RL (1964) The topographic anatomy of human skin. *Arch Dermatol* **89**: 155-161.
2. Forslind B (1984) Clinical applications of scanning electron microscopy and X-ray microanalysis in dermatology. *Scanning Electron Microscopy 1984*; I: 183-206.
3. Forslind B (1995) Skin replication for light and scanning electron microscopy. In: *Handbook of Non-Invasive Methods and the Skin*. Serup J, Jemec BE (eds). CRC Press, Ann Arbor, MI. Chapter 4.3.
4. Glauert AM (1974) *Practical Methods in Electron Microscopy*. Vol. 3. Fixation, Dehydration, and Embedding of Biological Specimens. North Holland, Amsterdam.
5. Jokstad A, Mjör IA (1991) Assessment of marginal degradation of restorations on impressions. *Acta Odontol Scand* **49**: 15-25.
6. Marks R, Dawber RPR (1971). Skin surface biopsy: an improved technique for the examination of the horny layer. *Br J Dermatol* **84**: 117-123.
7. Marks R, Pearse AD (1975) Surfometry. A method of evaluating the internal structure of the stratum corneum. *Br J Dermatol* **92**: 651-657.
8. Nayler JR (1984) Applications of the skin surface replica technique in dermatology. *J Audiovisual Media Medicine* **7**: 21-26.
9. Pameijer CH (1978) Replica techniques for scanning electron microscopy - a review. *Scanning Electron Microscopy*; 1978: II:831-836.
10. Pameijer CH (1979) Replication techniques with new dental impression materials in combination with different negative impression materials. *Scanning Electron Microscopy 1979*; II: 571-574.
11. Pfefferkorn G, Boyde A (1974) Review of replica techniques for scanning electron microscopy. *Scanning Electron Microscopy 1974*; I: 75-82.
12. Pfister TC, Neukirchner A (1980) Raster-elektronen-mikroskopische Untersuchungen am kranken Nagel mittels Abdruck-Verfahren (Scanning electron microscopic investigations of diseased nails by replica techniques). *Fortschr Med* **98**: 1465-1470.
13. Sampson J (1961) A method for replicating dry or moist surfaces for examination by light microscopy. *Nature* **191**: 932-933.
14. Tring FC, Murgatroyd LB (1974) Surface microtopography of normal human skin. *Arch Dermatol* **109**: 223-226.
15. Tring FC, Murgatroyd LB (1975) Psoriasis - Changes in surface microtopography. *Arch Dermatol* **111**: 476-480.
16. Wagner G, Goltz RW (1979) Human cutaneous topography. A new photographic technique: Observation on normal skin. *Cutis* **23**: 830-842.
17. Walsh TF, Waimesley AD, Carotte PV (1991) Scanning electron microscopic investigation of changes in the dentogingival area during experimental gingivitis. *J Clin Periodontol* **18**: 20-25.
18. Wolf J (1939) Die innere Struktur der Zellen des Stratum desquamans der Menschlichen Epidermis (The inner structure of the cells of the stratum desquamans of the human epidermis). *Z Mikr Anat Forsch* **46**: 170-202.

### Discussion with Reviewer

**S.L. Erlandsen:** In your discussion of the silicone elastomer technique, you indicate that you have achieved a resolution of at least 100 nm. Can you describe how this resolution was achieved and on what tissue? Was it verified by examination with a different type of imaging?

**Author:** This refers to positive Araldite replicas of stratum corneum where you can discern surface structures that are the reminders of desmosomal contacts. It was not verified by a different type of imaging. The final resolution test for the silicone elastomer replication remains to be done, preferably by replication of high definition gratiules etched on metal surfaces.