

Structural Analysis of Casings in High Temperature Geothermal Wells in Iceland

Gunnar Skúlason Kaldal, Magnús Þ. Jónsson, Halldór Pálsson, Sigrún Nanna Karlsdóttir

Faculty of Industrial Engineering, Mechanical Engineering and Computer Science, University of Iceland, Hjarðarhagi 2-6, 107 Reykjavík, Iceland

gunnarsk@hi.is

Keywords: Casing, structural analysis, concrete, finite element, thermal loading, thermal expansion

ABSTRACT

Large temperature changes are a central design concern in a diverse range of structures. Large and quick wellbore temperature changes in high temperature geothermal wells, e.g. during discharge and quenching of wells, produce large thermal stresses in the production casing which can cause casing failures. The wellbore temperature change during discharge causes the wellhead to rise due to thermal expansion of the casings, since the wells are constructed of several concentric steel casings which are fully cemented to the top. The structural integrity of such casings is essential for the utilization of high temperature geothermal wells. The casings in connection to the wellhead form a structural system which involves nonlinear interaction of the contacting surfaces. Therefore, the structural system is analyzed numerically with the use of the nonlinear finite element method (FEM). Three FEM models are presented here with the purpose of evaluating the structural integrity of high temperature geothermal well casings. A load history is used in the analysis, consisting of transient wellbore temperature and pressure changes.

1. INTRODUCTION

Energy of deep geothermal heat sources is extracted from geothermal reservoirs through geothermal wells. The energy rich water turns to steam as the pressure drops while it flows up the well. High temperature geothermal wells are often constructed of three concentric casings; a surface casing, an anchor casing and a production casing where the geothermal fluid flows. The casing components that form the casing are either connected with threaded couplings or welded together. Each casing is cemented externally all the way to the top for structural support and leakage prevention. The purpose of the casings is multifold; to prevent collapse of the borehole, to prevent flow from unwanted aquifers, for blow out prevention during drilling and to be a conductor for the geothermal fluid to flow up the well (Björnsson et al., 1978). The anchor casing is connected to an expansion spool below the master valve, allowing for axial displacement for the production casing inside the wellhead when it expands thermally. Numerous casing load cases arise during different stages of geothermal wells, see Figure 1, the main ones being; casing weight (A), differential pressure between outer and inner surface of the casing (B) and temperature changes (C and D).

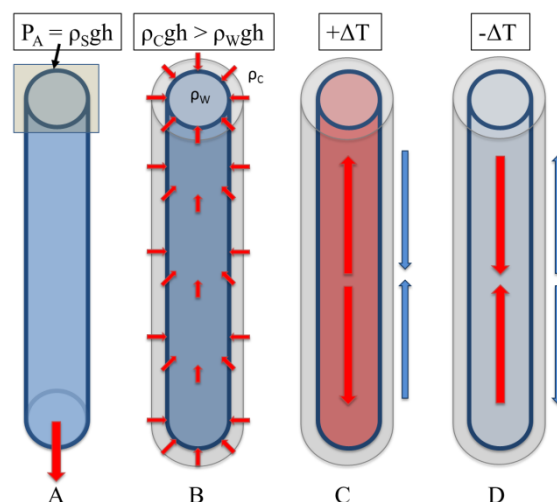

Figure 1: Main load cases of casings; (A) Self weight, (B) Differential pressure and (C and D) Temperature changes.

In general, casing strength is calculated in terms of axial tensile strength, collapse and burst pressures. The most important design loads for oil and gas are casing weight, tensile loading and fluid pressure, in geothermal wells however, high temperature loading is the most severe (Hole, 2008). The temperature change from the cementing temperature conditions to production temperature conditions is typically around 200-300°C uppermost in the well, but the temperature distribution of the casings during cementing provides the initial conditions for thermal stress calculations. Thermal expansion generates thermal stress in the casings and concrete because of the thermal gradient in between the layers. Assuming completely constrained casing, the thermal stress is about 2.5 MPa/°C, which means that a K55 steel casing reaches its yield point ($f_{ym} = 379$ MPa) at a temperature change of approximately 150°C. Fortunately, K55 casing steel is very ductile and can therefore generate large strain before problems occur. A well composed of concentric steel casings, concrete and surrounding rock formation forms a structural system which involves a number

of structural components, e.g. friction between contacting surfaces, tensile and compressive properties of materials and diminished material properties at elevated temperatures, all of which add nonlinear characteristics to the structure. The load subjected on the structure, the cased well, consists of transient wellbore pressure and temperature changes. The temperature rise while the well is initially discharged can lead to stresses reaching the yield strength of the casing which results in formation of plastic strain. The plastic strain is permanent so if the well cools down again, the plastic strain leads to tensile forces in the casing. These tensile stresses may be large enough to exceed the coupling joint strength of the casing which could result in casing failure (Maruyama et al., 1990). Because the well is composed of alternating layers of casings and concrete, the innermost casing, the production casing is most affected by temperature changes and the external casings are somewhat protected against thermal shocks by the insulation effect of the concrete in between. When initially cold wells are discharged, the thermal shock leads to sudden thermal expansion of the production casing which results in the production of large thermal stresses. Same applies when wells need to be quenched with cooling water, where instead of thermal expansion the cooling results in thermal contraction of the production casing. It's therefore favorable for the production casing that all the casings warm up as uniformly and with as little thermal gradient between them as possible. For that reason slow wellbore temperature changes are required, this can however be difficult to control. Recently, interests have developed in drilling deeper wells. With deeper wells the casing design becomes more challenging due to increased casing depths, higher pressures and temperatures and difficult corrosive environment. Therefore, it's important to know the structural risks involved.

A high temperature geothermal well consisting of a number of concentric cemented steel casings forms a nonlinear structural system where nonlinearities are found in material properties, large displacements and connection between contacting surfaces. The nonlinear finite element method (FEM) is used to construct three models of the cased well providing a tool which can be used to assess casing failure risks by modeling various possible load scenarios that could lead to casing problems. Such modeling also provides evaluation prospects of different materials that could be used in future wells. In this paper, three FEM models of high temperature geothermal well casings and numerical results are presented, some of which have previously been presented.

2. MODELING

2.1 Models

The analysis of the structural system of a high temperature geothermal well can be divided into categories depending on what is to be studied. A specific failure mode, such as a local casing failure, does not necessarily require a full 3D modeling of the whole well – a section of the well could be sufficient to explain the failure mode. In this paper, three models are essentially used to analyze different aspects of the structural system of the high temperature geothermal well; (i) a 2D axisymmetric model of the whole cased well used to model temperature, displacements, stress and strain distributions down the well, (ii) a 2D axisymmetric model of a detailed coupling surrounded by concrete used to further model coupling strength and concrete damage near couplings, and (iii) a 3D model of a section of the well which can be used to model non-symmetric phenomena such as collapse. Casing failure modes and the corresponding FEM models that are used to analyze them are listed in Table 1.

Table 1: Casing failure modes and corresponding FEM model used for analysis.

Failure mode	Description	FEM model
Axial tearing	Tearing at couplings due to high tensile stress.	(i) 2D axisymmetric model of the whole cased well. (ii) 2D axisymmetric model of a detailed coupling surrounded by concrete.
Collapse	Collapse due to pressure difference between the outer and inner pipe wall.	(iii) 3D model of a section of the well, includes impurities and geometrical defects, i.e. manufacturing tolerance, off center casing, external defect, eccentricity and ovality of the casing.
Burst	Rupture due to high internal pressure and low external pressure.	Not specifically modeled.
Concrete damage	Concrete braking because of stress reaching beyond the strength of the concrete.	(i) 2D axisymmetric model of the whole cased well. (ii) 2D axisymmetric model of a coupling surrounded by concrete. (iii) 3D model of a section of the well.
Wellhead displacement	Wellhead displacement due to wellhead pressure and wellbore temperature change.	(i) 2D axisymmetric model of the whole cased well.

Eight-node quadrilateral-shaped elements and six-node triangle-shaped elements are used in the 2D analyses, and 20-node structural solid elements are used in the 3D analysis. Contact element pairs are used between contacting surfaces with the main purpose of preventing intersection of surfaces, while still allowing gap formation and frictional displacement between casing and concrete surfaces. The Coulomb friction model is used to describe friction between contacting surfaces.

The largest of the three models, the (i) 2D axisymmetric model of the whole cased well is used to analyze the structural response of wells to wellbore temperature and pressure changes, see Figure 2. The geometrical sizes and material properties of a particular well and a load history of the well can be read into the model with specific input files. Temperature, displacements, stresses and strains of the casings and concrete at any depth is the output of the model. The structural response of geothermal wells to various load cases can therefore be analyzed. Wellhead displacement due to wellbore temperature changes and wellhead pressure can also be modeled with the model and the model shows correlation with measured wellhead displacement. The model is further described by Kaldal et al. (2013b, 2014).

The (ii) 2D axisymmetric model of a detailed coupling is used to analyze buttress couplings which have been cemented. The interaction between the casing, coupling and the concrete can therefore be modeled. The structural integrity of the concrete near the couplings can also be specially focused on, but all three models show signs of concrete damage near the couplings which are

essentially anchored in the concrete. Results from the two-dimensional model of the whole cased well can be superimposed on this model thus improving the resolution of the results. The geometry of the model can be seen in Figure 4. The boundaries of the model are located 3.5 meters up and down from the center of the coupling and 2 meters outwards from the center of the well.

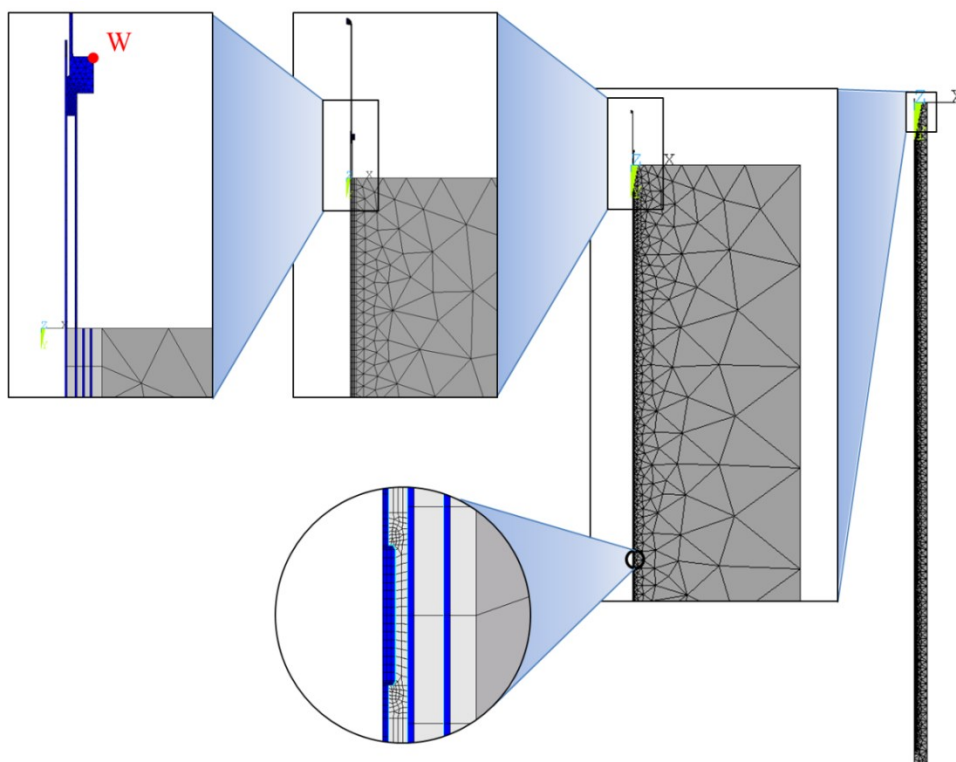

Figure 2: Model i, 2D axisymmetric model of the whole cased well used to model temperature, displacements, stress and strain distributions down the well. W denotes the node location where the wellhead displacement is followed, Kaldal (2013b, 2014).

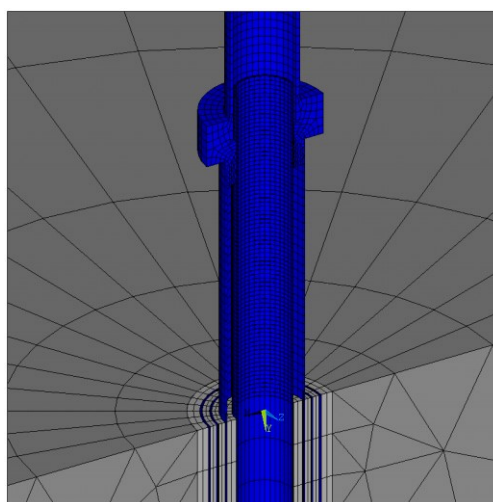

Figure 3: Symmetry expansion (180°) of the wellhead of model i.

The (iii) 3D model of a section of the well is used to model collapse of the production casing. A number of collapse analyses with various geometric imperfections, material impurities and combinations of loads have been modeled by Kaldal (2011, 2013a) where the model is further described.

2.2 Material properties

All models share the same material properties, the default material properties values are listed in Table 2. Tensile data by Karlsdottir and Thorbjornsson (2009) is used for the nonlinear stress-strain curves in the model. The strength reduction of casing steel at elevated temperatures has been tested and presented by Thomas (1967) and Snyder (1979), where reduction of the Young's modulus, yield strength and tensile strength are reported, but accurate stress-strain curves are not available. The stress-strain data in

the model is therefore scaled according to the reduction in Young’s modulus and yield strength with increased temperature. In the model the maximum compressive strength of concrete is defined as 27.6 MPa and when the maximum compressive strength is reached the concrete is assumed to yield plastically. The coefficient of friction between steel and concrete is defined as $\mu = 0.45$ and the maximum shear strength between the surfaces is defined as $\tau_{max} = 0.46\text{MPa}$, which is the mean value of two separate push-out shear strength tests of externally cemented casings performed by Gretarsdottir (2007) and Wallevik et al. (2009).

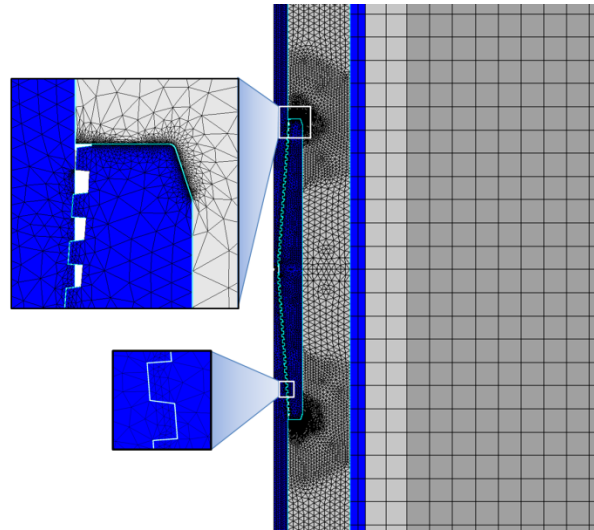

Figure 4: Model ii, 2D axisymmetric model of a detailed coupling.

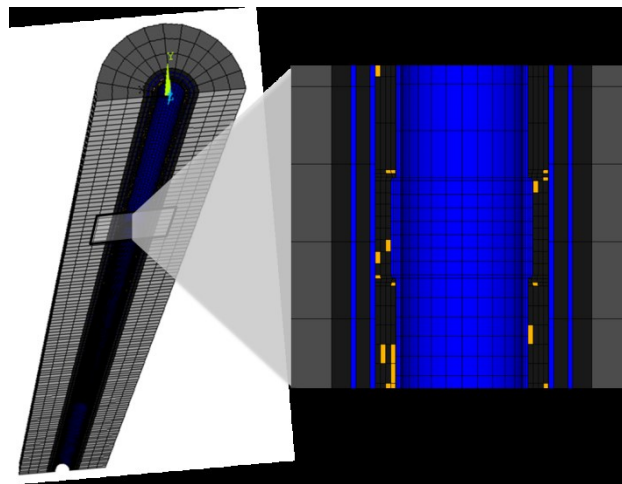

Figure 5: Model iii, a 3D model of a section of the well which is used to model non-symmetric phenomena such as collapse, Kaldal (2011).

Table 2: Default values of several material properties used in the FEM models. Other material properties are discussed in the text.

Item	Symbol	Unit	Steel	Concrete	Rock
Young's modulus	E	GPa	205	2,40	80.0
Poisson's ratio	γ	-	0.30	0.15	0.31
Density	ρ	kg/m ³	7850	1600	2650
Thermal conductivity	K	W/(m°C)	50	0.81	2.00
Specific heat	c	kJ/(kg°C)	0.40	0.88	0.84
Thermal expansion	α	1/°C	12e-6	10e-6	5.4e-6

2.3 Loads

In all cases the models are divided into two parts, a thermal part and a structural part. The thermal analysis precedes the structural analysis and calculates the transient temperature distribution of the model. The resulting temperature distribution is then used as temperature load in the structural analysis. In model i, the 2D axisymmetric model of the whole cased well, the load is based on wellbore temperature and pressure data which is logged down the well. In models ii and iii, the load is uniform inside the well,

since only a small section of the well is modeled. A load history of the well, i.e. the wellbore temperature and pressure changes with time, are important to evaluate the stresses that form during the lifetime of the well. A short load history of a well is listed in Table 4. The initial stress of the casings is important to evaluate further stress formation. It consists of casing weight and tensile stress due to cooling of the casing, from cementing conditions to further drilling with cooling fluid. The temperature distribution when the cement sets provides the initial conditions for calculating subsequent thermal stresses in each casing.

3. RESULTS AND DISCUSSION

3.1 Structural analysis of the whole cased well and detailed coupling

The casing program of the modeled well is listed in Table 3 and the load history of the well is listed in Table 4. The initial condition of the surrounding rock formation is the assumed virgin temperature before the well is drilled. When installed, the casings are assumed to hang free from the top before they are cemented and the temperature distribution of the casings during cementing provides the initial temperature for thermal stress calculations. Therefore, the initial conditions of the casings are (a) tensile stress due to casing weight and (b) tensile stress due to cooling, from the cementing temperature distribution to the drilling fluid temperature from further drilling.

Table 3: The casing program of the modeled well.

Casing	Outer diameter [inches]	Thickness [mm]	Depth [m]	Steel grade
Production casing	13 3/8	12.2	700	K55
Anchor casing	18 5/8	11.0	300	K55
Surface casing	22 1/2	11.0	75	X56

The load history of the well, listed in Table 4, consists of the initial conditions, cooling of the well due to drilling, temperature recovery, pre-discharge conditions where air-pressure is used for discharge assistance, discharge (ΔP and ΔT), and post-discharge where constant production conditions are assumed.

Table 4: A load history of the well for model i.

Nr.	Load case	Description	T_{wh} [°C]	$T_{@700m}$ [°C]	Time period
1.	Rock temperature	Assumed virgin temperature of rock formation.	11	210	Initial
2.	Cementing temperature	Initial temperature of casings when cemented.	4	107	Initial
3.	Cooling due to drilling	Cooling while drilling the total depth of the well.	5	10	40 days
4.	Temperature recovery	Well warm-up from cold conditions.	11	210	9 months
5.	Pre-discharge (air compressor)	T and P conditions prior to discharge assuming discharge assistance by pumping air into the well to increase wellhead pressure.	5	104	24 hours
6.	Discharge (ΔP)	Wellhead opened and pressure changes sharply.	5	104	1 minute
7.	Discharge (ΔT)	The wellbore temperature changes gradually.	203	240	12 minutes
8.	Post-discharge	Post discharge conditions followed assuming constant production.	203	240	9 days
9.	Post-discharge	Post discharge conditions further followed.	203	240	3 months

The temperature distribution of the well and the surrounding rock formation at different times in the load history are displayed in Figure 6. The geometry of the modeled wellhead and the displacement of the wellhead after going through the load history are displayed in Figure 7 and the modeled wellhead displacement during discharge can be seen in Figure 8. The wellhead displacement is fast during the first minute and then slows down.

Formation of stress during discharge near the topmost coupling of the production casing and the surrounding concrete is displayed in Figure 9. As the production casing expands due to thermal expansion, during the increasing wellbore temperature, the wellhead rises and large stress is produced in the surrounding concrete which warms up slower than the production casing. Similar production of stress is seen in the detailed coupling model (model ii), see Figure 12.

Axial stress in the production casing at various times in the load history of the well are plotted in Figure 10. The casing is initially in tension due to the casing weight and cooling from drilling, then when the well is allowed to warm up the tensile stress is decreased as the casings warm up from the outside. Since the well is warmer deeper in the well, compressive stress builds up as the casing expands thermally. In this case, air-compressor is assumed to be used to generate enough wellhead pressure in order for the well to be discharged. This cools down the casing and tensile stress is formed again. Now, the well is discharged and it warms up suddenly which generates high compressive thermal stress. Due to this, permanent strain is produced in the casing as the stress reaches above the yield strength of the material. As external casing layers slowly warm-up and the casings expand thermally, the stress is slowly reduced in the production casing.

When wells need to be quenched with cooling water in order to be shut down, large thermal stresses are produced. In Figure 11 the model is used to analyze the production of stress in the concrete near a production casing coupling during cooling. Cooling the well gradually over a longer period of time results in lower stress in the surrounding concrete due to lower thermal gradient between the casing and the concrete, this is shown in Figure 11.

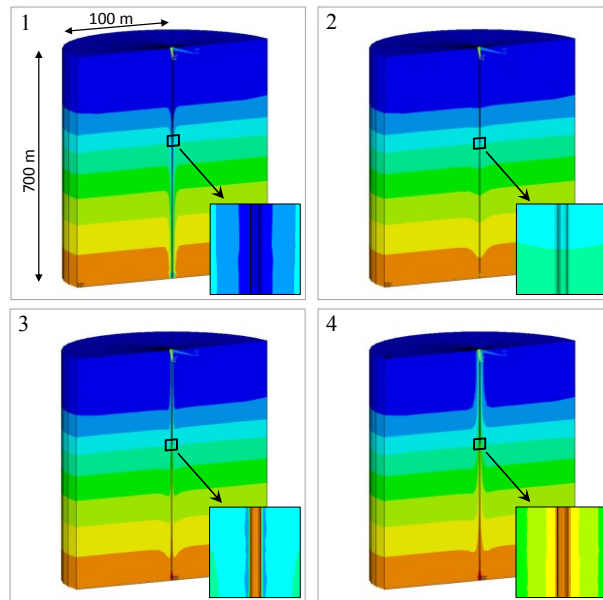

Figure 6: Temperature distribution of the well and formation at different times (180° symmetry expansion of model i). 1. Cooling due to drilling, 2. Warm-up, 3. Discharge (12 min), and 4. Discharge (3 months).

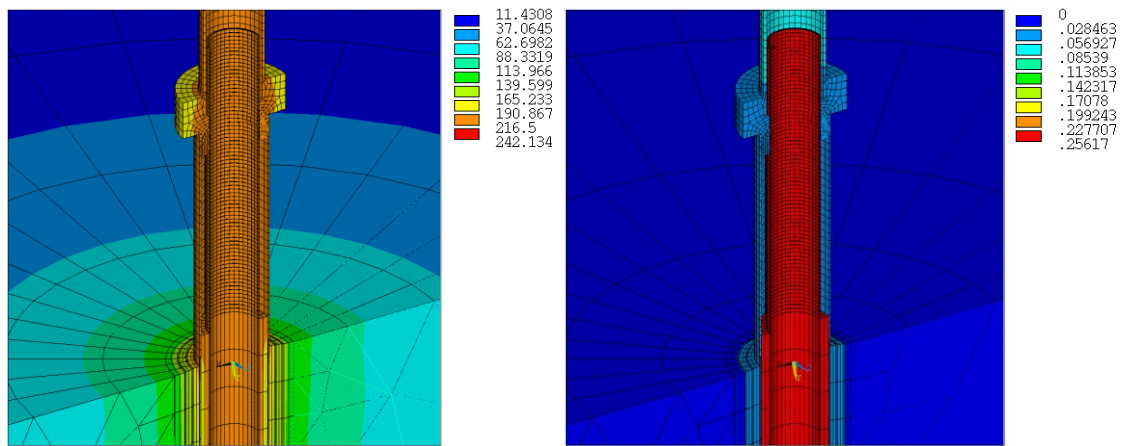

Figure 7: Left: temperature distribution of the wellhead three months after discharge (°C). Right: axial displacement of the wellhead (meters) after going through the load history that is listed in Table 4 (180° symmetry expansion of the wellhead of model i).

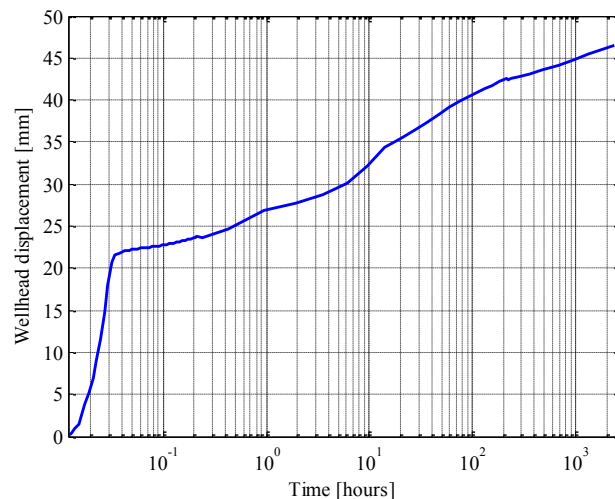

Figure 8: Modeled wellhead displacement of the well during discharge (model i).

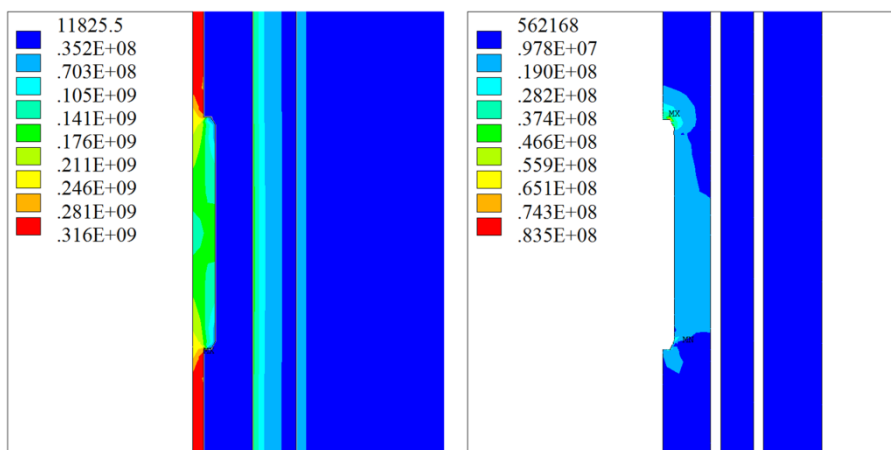

Figure 9: Stress (von Mises) in near the topmost coupling of the production casing during discharge (model i, concrete shown separately on the right), Kaldal 2014.

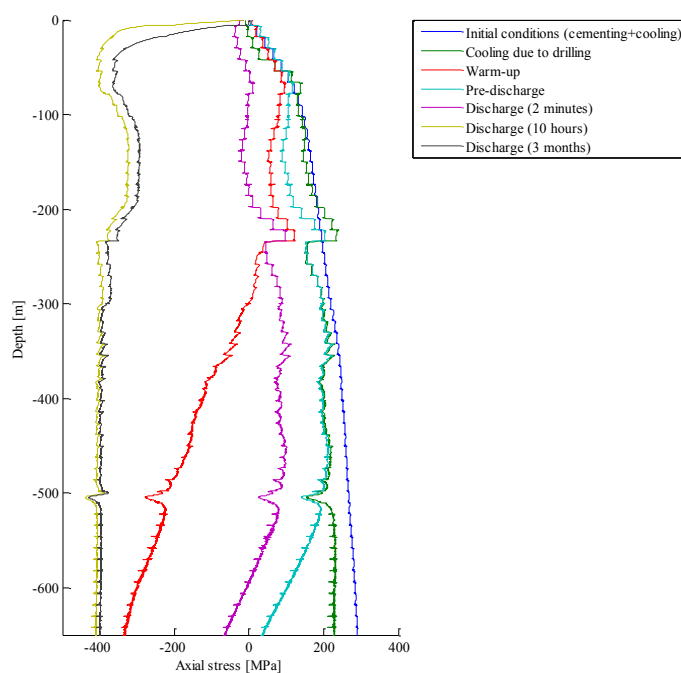

Figure 10: Axial stress in the production casing at different times in the load history analysis (model i).

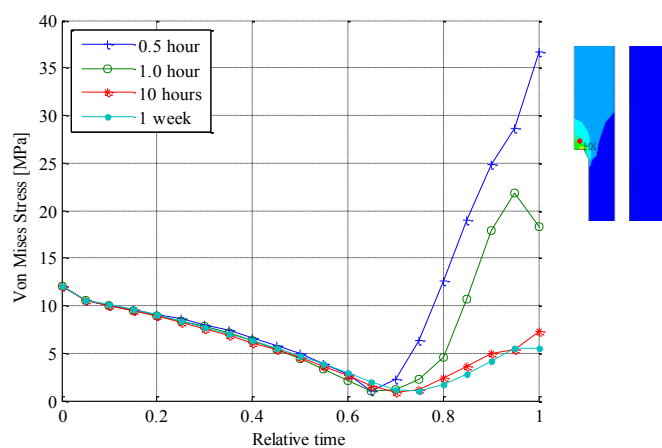

Figure 11: Comparison of stress in concrete near the topmost coupling of the production casing with different cooling times of a well (ΔT of $\sim 200^\circ\text{C}$).

The detailed coupling model is here used to further model concrete damage near the topmost coupling of the production casing in the well. First, the top end of the production casing is subjected to a displacement of 5 mm. This could be interpreted as tension due to a sudden cooling of the casing, or if the focus is on the concrete only, a displacement due to sudden thermal expansion in the top of the well. The displacement leads to tensile stress in the topmost threads of the coupling as is seen in the top left corner in Figure 12.

In this case, the concrete is modeled elastically, thus the stress is linear according to the Young’s modulus, and in each step the concrete elements are checked if they have exceeded the concrete compressive and tensile strength. The tensile strength is assumed to be 10% of the compressive strength. The elements that have exceeded the concrete strength are given diminished material properties to simulate concrete damage. These elements are colored red in the top right corner in Figure 12. Using this approach the large production casing displacement of 5 mm generates a concrete damage through the full thickness of the concrete.

Although this might be an overestimation, the analysis indicates that concrete damage could be substantial near the topmost couplings of the production casing where the casing displacement is not as restricted as it is deeper in the well.

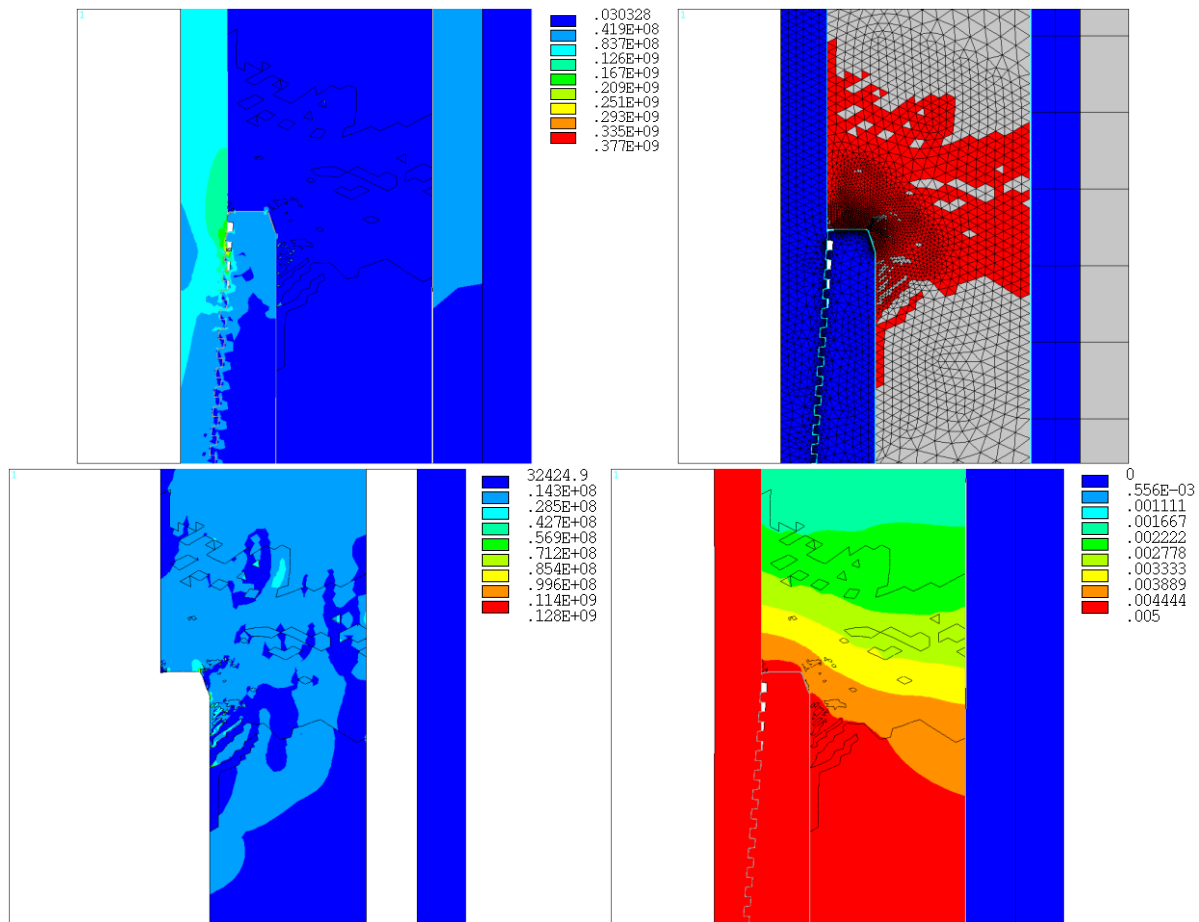

Figure 12: Model ii, analysis of the topmost coupling of the production casing, 5 mm upward displacement of the top end of the production casing. Top left corner: Stress (von Mises) in the casing and coupling due to displacement of the production casing. Bottom left corner: stress (von Mises) in concrete due to upwards displacement of the casing. Top right corner: concrete elements that have exceeded the compressive strength of the concrete are shown in red. Bottom right corner: displacement due to upwards casing displacement.

In the second analysis, the lower end of the production casing is subjected to the same displacement of 5 mm, see Figure 13. This could resemble sharp warm-up of the production casing. In this case, almost no stress is generated in the concrete near the top of the coupling, as the displacement fades out in the coupling. Instead, tensile stress is produced in the concrete near the bottom of the coupling.

In both these cases, concrete damage occurs near the coupling due to displacement of the production casing. If wells go through numerous discharge-cooling cycles, the top couplings in the production casing and the surrounding concrete might lose its sealing capacity and the topmost couplings of the casing might also become a weak point due to decreased support of the surrounding concrete.

3.2 Collapse analysis of the production casing of the well

Collapse analysis using the 3D model, where water is assumed to be trapped inside the annulus between the production casing and the external casing, is seen in Figure 14. The modeled casing has an outer diameter of 13 3/8 inch and wall thickness of 12.2 mm.

Imperfections, consisting of 80% water and 20% concrete, are randomly distributed in the area where the water is assumed to be trapped (Kaldal et al., 2011). In the analysis, the casing collapses at a load consisting of 300°C internal temperature and additional differential pressure between the outer and inner casing wall of 20 bars.

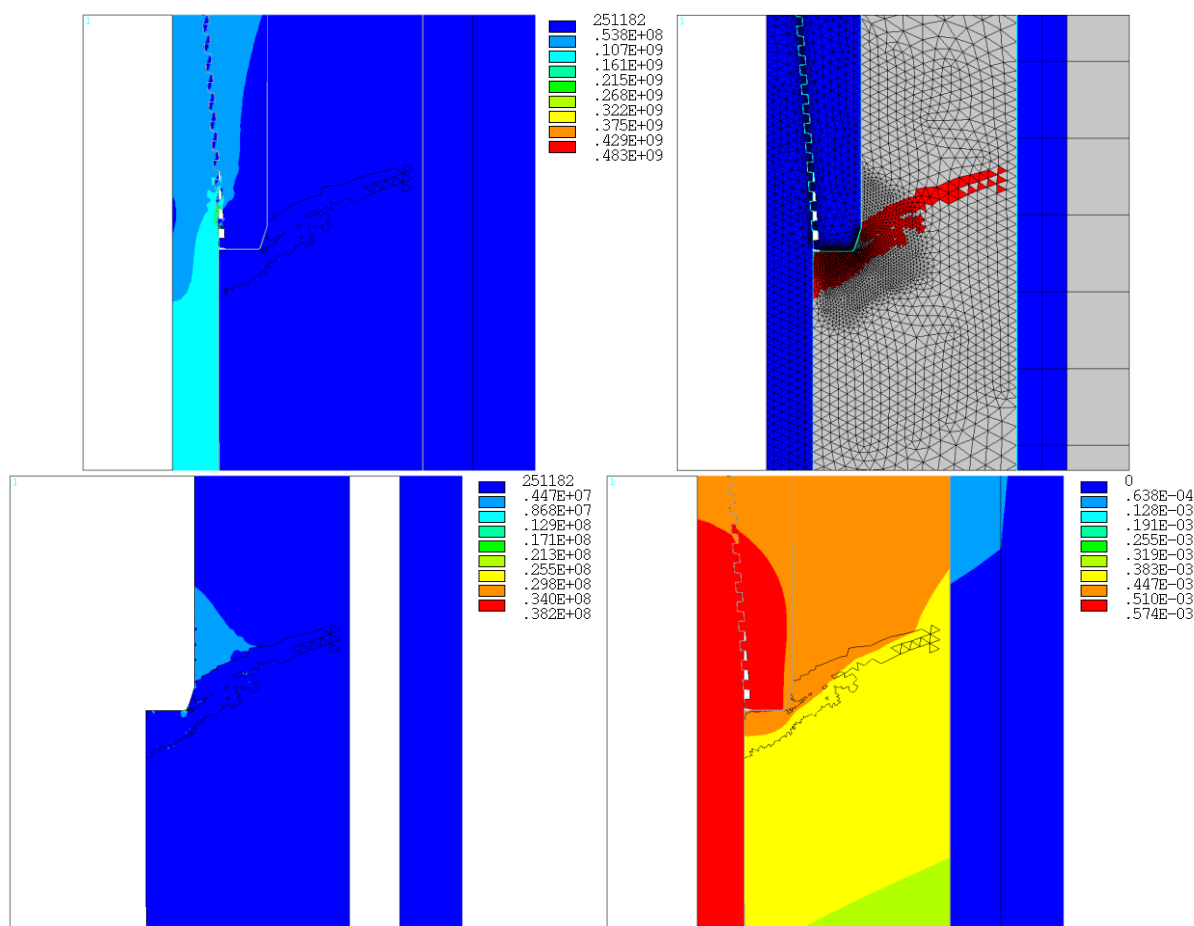

Figure 13: Model ii, analysis of the topmost coupling of the production casing, 5 mm upward displacement of the lower end of the production casing. Top left corner: Stress (von Mises) in the casing and coupling due to displacement of the production casing. Bottom left corner: stress (von Mises) in concrete due to upwards displacement of the casing. Top right corner: concrete elements that have exceeded the tensile strength of the concrete are shown in red. Bottom right corner: displacements due to upwards casing displacement.

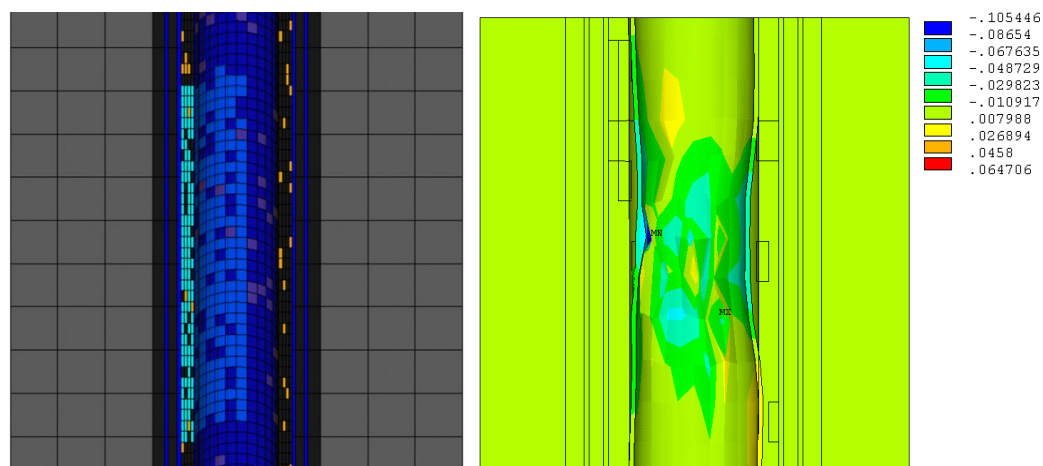

Figure 14: On the left: trapped water in concrete (water elements are cyan colored and production casing is transparent), Kaldal (2011). On the right: collapse at 300°C and 20 bar additional pressure difference between outer and inner casing wall (radial displacement in meters, 13 3/8 inch casing outer diameter with wall thickness of 12.2 mm, model iii), Kaldal (2011).

The effect of structural support of concrete and various defects have also been analyzed by Kaldal et al. (2013a). The results show how the collapse resistance of the modeled casing increases when support of concrete is added, see Figure 15 and Figure 16. The collapse shape of the casing that is structurally supported by concrete resembles collapse shapes that have been documented in high temperature geothermal wells. The results also show that defects and deformations, such as ovality and mode shape perturbation, results in reduction in collapse resistance of the casing of approximately 30-50% compared to a perfectly round casing, see Kaldal et al. (2013a).

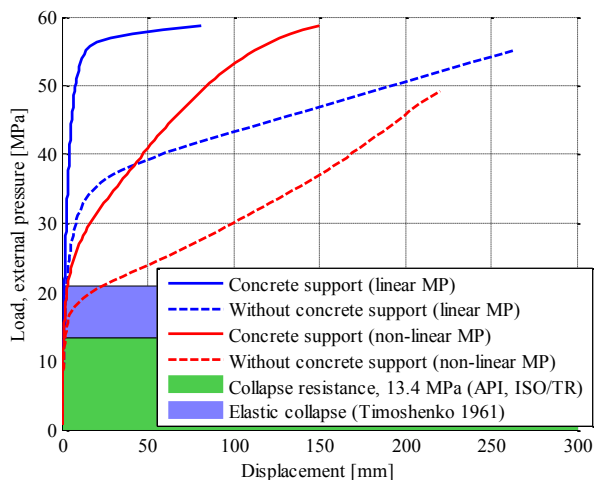

Figure 15: Load displacement curves comparing casing collapse with and without concrete support, external defect of 50% of the casing thickness is included, Kaldal (2013a).

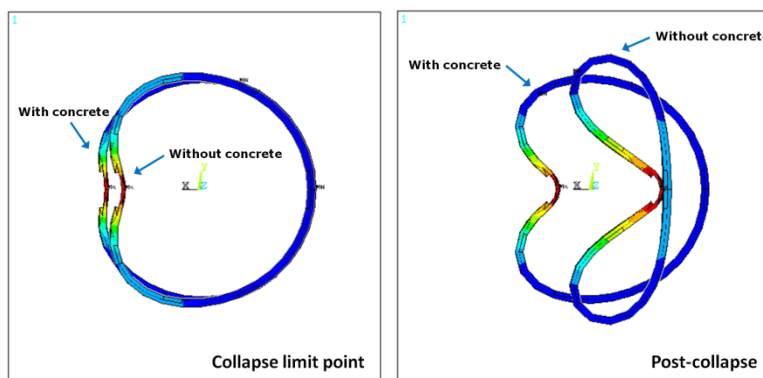

Figure 16: Collapse limit point and post-collapse with and without concrete support (cross-section view), Kaldal (2013a).

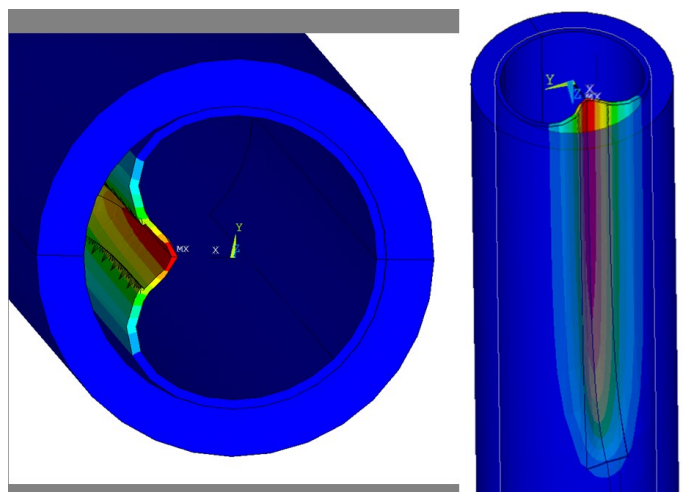

Figure 17: Collapsed casing with external defect with a depth of 40% of the wall thickness (13 3/8 inch casing outer diameter with wall thickness of 12.2 mm), Kaldal (2013a). Collapse occurs at external pressure of 13.3 MPa.

4. CONCLUSION

Analysis of a high temperature geothermal well using three FEM models was presented here. The results that were presented show how the models can be used to structurally evaluate the casing of the well. Possibilities of analysis by using these models are virtually unlimited in terms of load scenarios and material selection. By using the models, well design and well operations could be improved by analyzing material selection, casing sizes and various load scenarios during the lifetime of the well.

ACKNOWLEDGMENT

This work was financially supported by the University of Iceland research fund, the Technology Development Fund at RANNIS - The Icelandic Centre for Research, the Innovation Center Iceland, Landsvirkjun Energy Research Fund, and GEORG - Geothermal Research Group. Their support is much appreciated. The authors would like to thank Reykjavik Energy, HS Orka, Landsvirkjun, Iceland Drilling, Iceland Geosurvey, Mannvit and the Innovation Center Iceland for providing data and useful information for the work presented here.

REFERENCES

- Björnsson, G., Ragnars, K., Sigfússon, S., Karlsson, Þ.: Styrkleiki fðurröra í háhitaborholum (In Icelandic, translation: Casing Strength in High Temperature Wells). Orkustofnun, Virkir HF. and VST HF. Reykjavik (1978).
- Gretarsdóttir, S., 2007. Mechanical and thermal properties of well cement. Master's thesis. University of Iceland.
- Hole, H.: Geothermal well cementing. Petroleum Engineering Summer School Workshop 26, (2008)
- Kaldal, G. S., Jonsson, M. Þ., Pálsson, H., Karlsdóttir, S. N.: Load History and Buckling of the Production Casing in a High Temperature Geothermal Well. Proceedings, 36th Workshop on Geothermal Reservoir Engineering, Stanford University, Stanford, CA (2011).
- Kaldal, G.S., Jonsson, M. Þ., Pálsson, H., Karlsdóttir, S. N.: Thermal and structural analysis of the casing in a high temperature geothermal well during discharge. 37th Workshop on Geothermal Reservoir Engineering, Stanford University, Stanford, CA (2012).
- Kaldal, G. S., Jonsson, M. Þ., Pálsson, H., Karlsdóttir, S. N.: Collapse Analysis of the Casing in High Temperature Geothermal Wells. Proceedings, 38th Workshop on Geothermal Reservoir Engineering, Stanford University, Stanford, CA (2013a).
- Kaldal, G. S., Jonsson, M. Þ., Pálsson, H., Karlsdóttir, S. N.: Using probabilistic Analysis with Finite Element Modeling of High Temperature Geothermal Well Casings. SIMS 54th conference in Bergen, Norway, October 16-18 (2013b).
- Kaldal, G. S.: Structural Modeling of Casings in High Temperature Wells in Iceland (in Icelandic), *Vélabrögð*, **35**, (2014), 12-14
- Karlsdóttir, S.N., Thorbjörnsson, I.O.: High Temperature Geothermal Wells - Center of Excellence in Iceland - Phase I: Corrosion Testing of Steel in High Temperature Geothermal Wells in Iceland (in Icelandic). Technical Report for RANNIS (The Icelandic Centre for Research), Innovation Center Iceland, Reykjavik (2009).
- Maruyama, K., Tsuru, E., Ogasawara, M., Inoue, Y., Peters, E.J., 1990. An experimental study of casing performance under thermal cycling conditions. *SPE Drilling Engineering* 5, 156–164.
- Snyder, R.E.: Casing Failure Modes in Geothermal Wells. Geothermal Resources Council, (1979), 667–670.
- Thomas, P.D.: High temperature tensile properties of casing and tubing. API Division of Production 1967 Midyear Standardization Conference, San Francisco, CA (1967).
- Wallevik, S., Hjartarson, B., Alexandersson, K.F., Kubens, S., Oesterheld, S., Ólafur H. Wallevik, Ásgeirsdóttir, M.D., 2009. High Temperature Geothermal Wells - Center of Excellence in Iceland - Final report: Concrete Suited for High Temperature Geothermal Wells. Technical Report for RANNIS (The Icelandic Centre for Research), in Icelandic.