

Combination between CMA and On-Off Algorithms for Adaptive Array Antenna

#Tanawut Tantisopharak¹, Akkarat Boonpoonga², Phaophak Sirisuk² and Monai Krairiksh¹

¹Faculty of Engineering, King Monkut's Institute of Technology Ladkrabang
Bangkok 10520, Thailand, s8060960@kmitl.ac.th, kkmonai@kmitl.ac.th

²Department of Computer Engineering, Mahanakorn University of Technology
Nongchok, Bangkok 10530, Thailand, akkarat@mut.ac.th, phaophak@mut.ac.th

1. Introduction

During the last decade, an adaptive antenna has considerable received the interest for mobile communication systems. This is because it can increase the system capacity by reducing interference. To achieve the interference reduction, an adaptive algorithm is necessary. There are a number of the adaptive algorithms proposed to improve the signal-to-interference plus noise ratio (SINR) in such the systems i.e. [1]. Recently, an adaptive on-off algorithm was introduced to achieve a high SINR [2]-[3]. This approach maximizes the array output power. The SINR improvement using the algorithm depends on the strength of received signals. Namely, the algorithm work well if the power of the desired signal is sufficiently stronger than that of interference. It is know that generally an adaptive antenna using on-off algorithm adjusts its main beam to the desired signal. Nevertheless, its nullity does not appear at the interference direction.

Another popular adaptive algorithm recently proposed in [4] is a constant modulus algorithm (CMA) which is a blind algorithm. The algorithm does not need a training sequence for adaptation. It can eliminate interference with the condition that the transmitted signal has a constant envelope, for example, a frequency- or phase-modulated signal. This is because the interference signal involves the amplitude fluctuation on the received signal. The main drawback of applying the CMA to the adaptive antenna system is its slow convergence property. It was reported that the convergence behavior of CMA heavily depends on its initial condition [5]. Recently, the problem of CMA convergence property was resolved by using the concept of the digital beam-switching initialization for CMA [6]. However, it is still sensitive to convergence because there are only sixteen initial beams used for adaptation of CMA. Moreover, an adaptive antenna using CMA has a nullity at the interference signal but it does not guarantee whether its main beam directs to the desired signal.

In this paper, we propose a combination between CMA and on-off algorithms. The on-off algorithm is utilized to generate an initial beam for CMA. Then, CMA is used for adaptation to eliminate interference. After introduction, a combination between CMA and on-off algorithms is presented via its derivation in Section 2. Simulation results are shown to validate the performance of the proposed technique in Section 3. Finally, the conclusions are drawn in Section 4.

2. On-off and CMA Adaptive Array Antenna

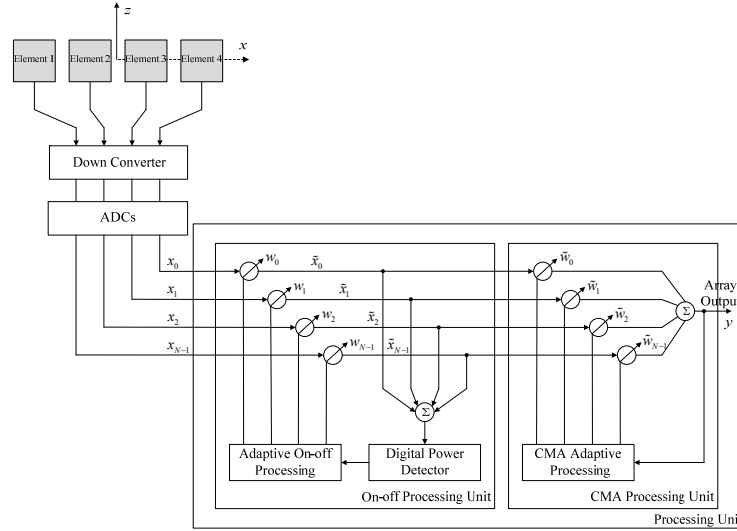

Figure 1: Architecture of the proposed technique

Fig.1 depicts the architecture of the proposed adaptive array antenna using a combination between on-off and CMA algorithms. The four-element linear array antenna with element spacing d of 0.25λ is used. The complex signals received by n^{th} antenna element and then down converted are digitized by analog-to-digital converters (ADCs). The received signals can be defined as

$$\mathbf{x}(k) = \mathbf{A}\mathbf{s}(k) + \boldsymbol{\eta}(k) \quad (1)$$

where $\mathbf{s}(k)$ and $\boldsymbol{\eta}(k)$ are the transmitted signal and additive noise vectors, respectively. The matrix $\mathbf{A} = [1 e^{-jkdcos\phi} \dots e^{-j(n-1)kdcos\phi}]^T$ denotes an array response and the received signal vector is defined in [6]

The adaptive on-off algorithm is used for yielding the maximum array output power. The adaptive weight is updated by

$$w(i) = e^{j\alpha(i)} \quad (2)$$

Here, α is a progressive phase between each element, which can be obtained from

$$\alpha = -kd \cos \phi_0 \quad (3)$$

where ϕ_0 are the main beam directions in azimuthal plane and can be adjusted by using the iterative algorithm as given by

$$\phi_0(i+1) = \phi_0(i) + \psi(i) \quad (4)$$

where $\psi(i)$ is the on-off variable which is chosen for the weight drives the output power to its maximum using the rule that [2]

$$\frac{dP(t)}{dt} \begin{cases} > 0 & D = 1 \\ < 0 & D = -1 \end{cases} \quad (5)$$

1) if $D = 1$, then $\psi(i+1) = \psi(i)$ and this means that if the output power $P(t)$ increases, then the direction of the next iteration is in the same direction as the previous one.

2) if $D = -1$, then $\psi(i+1) = -\psi(i)$, and this means that $P(t)$ is decreasing. Therefore the direction of the next iteration must be changed.

Hence, $D = 1$ is maintained as long as power increases.

The output from on-off algorithm has been used as the effective input of the CMA antenna system $\tilde{\mathbf{x}}(k)$ which can be expressed as

$$\tilde{x}_i(k) = w_i x_i(k). \quad (6)$$

Collecting the effective input $\tilde{x}_i(k)$, we may write

$$\tilde{\mathbf{x}}(k) = [\tilde{x}_0(k) \tilde{x}_1(k) \dots \tilde{x}_{N-1}(k)]^T. \quad (7)$$

The complex effective input signal $\tilde{x}_i(k)$ is then multiplied by an adjustable complex weight $\tilde{w}_i(k)$. Therefore, using matrix-vector notation the adaptive array output is written as

$$y(k) = \tilde{\mathbf{w}}(k)^H \tilde{\mathbf{x}}(k) \quad (8)$$

where

$$\tilde{\mathbf{w}}(k) = [\tilde{w}_0(k) \tilde{w}_1(k) \dots \tilde{w}_{N-1}(k)]^T \quad (9)$$

where H is the vector conjugate transpose. The CMA adjusts the weight vector $\tilde{w}(k)$ in a way that the cost function is minimized based on the stochastic gradient steepest descent method. The weight updated equation is defined as [4]

$$\tilde{w}(k+1) = \tilde{w}(k) - 4\mu\tilde{x}(k)y^*(k)(|y(k)|^2 - \sigma^2). \quad (10)$$

3. Simulation Results

The simulations were conducted to evaluate the performance of the proposed system. The desired and interference signals were $\pi/4$ -QPSK-modulated and propagated through an additive white Gaussian noise (AWGN) channel. In practical wireless environments, the desired signal power is normally larger than that of the co-channel interference. Here, the power of the desired signal was set to be 3 dB stronger than that of interference. The signal-to-noise ratio (SNR) was set to be 30 dB. In our simulations, the incident angle of desired (ϕ_D) and interference (ϕ_I) signals were 30° and 150° , respectively. Fig.2 illustrates the radiation pattern of the antenna after adjusting the main beam direction to the desired signal direction by using an on-off algorithm. With the on-off algorithm, the main beam of the antenna directs to 30° (desired signal direction) as seen in the figure. However, the nullity does not appear at the interference direction (150°). The resulting SINR is not enough. Therefore, the SINR should be further increased by using CMA in order to increase SINR.

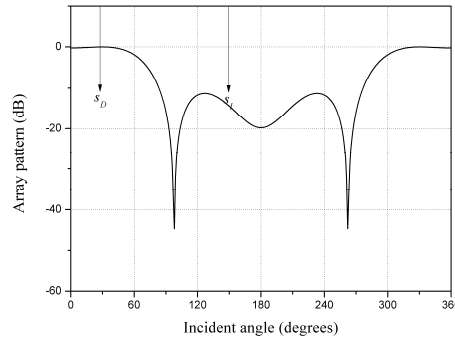

Figure 2: Radiation pattern obtained from only on-off algorithm.

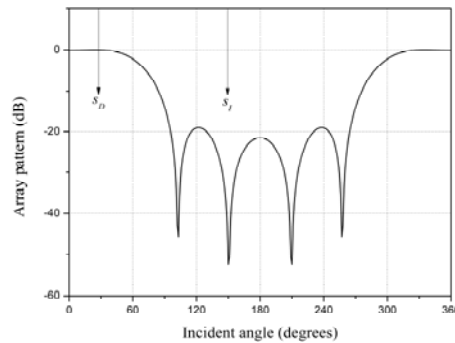

Figure 3: Radiation patterns obtained from a combination of CMA and on-off algorithm.

The antenna pattern obtained from the on-off algorithm is used as an initial beam for CMA. Fig.3 shows the radiation pattern after respectively performing on-off and CMA algorithms. The main beam of the antenna obtained from on-off and CMA algorithms direct to 27° close to the desired signal direction (30°) as seen in the figure in which the nullity appear at 150° . By using a combination between CMA and on-off algorithm, it is clear that the main beam and nullity of the final antenna pattern are in the direction of the desired signal and interference, respectively.

Table 1: SINR obtained from the adaptive array antenna

Incident Angle	SINR (dB)	
	On-off Algorithm	Proposed System
$\phi_D=30, \phi_I=150$	14.4	50.2
$\phi_D=60, \phi_I=150$	11.7	50.2
$\phi_D=90, \phi_I=150$	15.8	50.0
$\phi_D=30, \phi_I=100$	27.4	50.2
$\phi_D=60, \phi_I=100$	7.5	49.9

Besides only a simulation case seen above, Table 1 shows the SINR improvement with five different cases of the incident angles of the received signals. As seen in the table, all SINRs obtained from the conventional on-off algorithm are relatively small, which depend on the antenna pattern. The SINRs obtained from a combination of CMA and on-off algorithms are approximately 50 dB higher than that from only on-off algorithm. The on-off algorithm adjusts only the antenna main beam to the desired signal while does not guarantee whether the nullity of the antenna appears at the interference direction. On the other hand, the antenna pattern obtained from performing only a CMA has the nullity at the interference direction but its main beam does not direct to the desired signal direction. According to Fig. 3 and table 1, it reveals that the proposed system operates very well by reducing the interference and maximizing the array output power.

4. Conclusions

In this paper, a combination of CMA and on-off algorithms has been proposed. In the proposed technique, an on-off algorithm is utilized to maximize the array output power. The beam whose main beam almost direct to the desired signal is employed as an initial beam for CMA. With the initial beam, CMA is used to adjust the nullity of the antenna to the interference signal. The simulation results show that the nullity obtained from the proposed antenna appears at the interference direction while the main beam directs to the desired signal.

Acknowledgments

This work was supported by the Senior Research Scholar Program (Grant No. RTA 5180002).

References

- [1] T. Sukhonthaphong, P. Ngamjanyaporn, C. Phongcharoenpanich and M. Krairiksh, "Covariance Matrix Adjustment for Interference Cancellation Improvement in Adaptive Beamforming," ECTI Trans. Electric. Eng., Electron., and Commun., Vol. 1, no. 1, pp. 27-37, Aug. 2003.
- [2] T.A. Denidni and G.Y. Delisle, "A Nonlinear Algorithm for Output Power Maximization of an Indoor Adaptive Phased Array," IEEE Trans. Electromagn. Compat., Vol. 37, no. 2, pp. 201-209, May 1995.
- [3] T.A. Denidni, D. McNeil and G.Y. Delisle, "Experimental investigations of a new adaptive dual-antenna array for handset applications," IEEE Trans. Veh. Technol., Vol. 52, no. 6, pp. 1417-1423, Nov. 2003.
- [4] J.R. Treichler and B.G. Agee, "A New Approach to Multipath Correction of Constant Modulus Signals," IEEE Trans. Acoust. Speech Signal Process., ASSP-31, no. 2, pp. 459-472, Apr. 1983.
- [5] K. Takao and H. Matsuda, "The Choice of Initial Condition of CMA Adaptive Arrays," IEICE Trans. Commun., Vol. E78-B, no. 11, pp. 1474-1478, Nov. 1995.
- [6] T. Tantisoparak, A. Boonpoonga, P. Sirisuk and M. Krairiksh, "Simple Initialization Scheme for CMA Adaptive Antenna by Using Digital Beam Synthesis," Proc. 5th Int. Conf. Electrical Engineering/Electronics, Computer, Telecommunications and Information Technology (ECTI-CON 2008), Vol. 1, pp. I-289-I-292, May 2008.