

INTELLIGENT HOME: SMS BASED HOME SECURITY SYSTEM WITH IMMEDIATE FEEDBACK

¹Pankaj Kumar Yadav, ²Kumari Ratna Priya ³Deepali Srivastava

⁴Netra Kumari, ⁵Harendra Pal Singh

^{1,2,3,4} UG Student, Department of Electronics & Communication Engineering,

⁵Associate Professor, Department of Electronics & Communication Engineering,
Accurate Institute of Management & Technology, Greater Noida, UP (India)

ABSTRACT

A low cost Short Message System (SMS) based Home security system equipped with motion, smoke, temperature, humidity and light sensors has been studied and tested. The sensors are controlled by a microcontroller through the SMS having password protection code for the secure operation. The user is able to switch light and the appliances and get instant feedback. Also in cases of emergencies such as fire or robbery the system will send alert message to occupant and relevant civil authorities. The operation of the home security has been tested on Vodafone- Fiji network and Digicel Fiji Network for emergency and feedback responses for 25 samples. The experiment showed that it takes about 8-10s for the security system to respond in case of emergency. It takes about 18-22s for the occupant to switch and monitor lights and appliances and then get feedback depending upon the network traffic.

Keywords: Smart Home, SMS, Sensors, Microprocessor.

I INTRODUCTION

Smart Home' referred to as 'Intelligent Home' or 'Automated Home', indicates the automation of daily tasks with electrical devices used in homes. This could be the control of lights or more complex chores such as remote viewing of the house interiors for surveillance purposes. The emerging concept of smart homes offers a comfortable, convenient, and safe environment for occupants. Wireless technologies had some amazing achievements in automating homes via Bluetooth, ZigBee, and Wi-Fi but had a limited connectivity range. The use of internet is also being probed to develop automated home technologies. Mobile phones have become one of the most common communication devices amongst the people all over the world. SMS became popular as it provides cheap, convenient and faster method of communication. Unlike the Internet, SMS is safe from network security threats and can be operational from anywhere in the world where there is a mobile network. The advantage of SMS over ZigBee, Bluetooth and Wi-Fi is that it is communication range from anywhere in the world where is mobile network.

The penetration of internet connection for home automation is the new dimension as technologies continues to grow. Global System for Mobile Communication (GSM) module was then introduced for home automation. The GSM module system is battery powered which made home automation system safer from internet hacks. Home automation has also further advanced in successfully merging communication technologies GSM module, internet, and speech recognition system. The wireless automation reduces the cost of the system unit as well as it is much easier to install. The GSM module has advanced to automobiles. It is interfaced with the car ignition system where the owner carries the mobile phone rather than to carry around the key. Recent advances in the automation showed that the billing system for electricity, gas or water uses GSM module based SMS metering service rather than assigning person to visit each house and read the meter readings manually in cases of South Pacific. However, the GSM module has some drawbacks as it cannot behave like what the actual mobile does. GSM module users have to remove the SIM card for recharge top-up. There is more exposure in using the GSM network if only the mobile is interfaced rather than GSM module. In this paper we present SMS based Smart Home with feedback response. This system interfaces the mobile phone with embedded microcontroller and sensors which is based in the intelligent home. The user can use SMS for monitoring and controlling lights, home appliances and security sensors and get feedback on the same mobile phone about the status of different appliances. The entire system is password protected which can only be changed by the user. The system is generic as it can work with any mobile network. The system designed has two way switching properties which means that the home 240V AC or 110VAC electrical appliances, lights, appliances and sensors can be switched on and off by mobile phone and also by the manual switches.

II CONTROL, ARCHITECTURE AND MANAGEMENT OF THE SYSTEM

The overall architecture design and networking of the home system is shown in Fig. 1. The system first it checks the battery charge level of the mobile phone every cycle of the coding, that is, about 15 seconds and automatically turns on the battery charger if battery level is below 30%. It then reads the message received by the mobile phone interfaced with the microprocessor. The microprocessor then stores the phone number from which the message is received for feedback purpose. If the message indicates low credit, it sends call back message to user indicating that credit is low (Callback message is free for Vodafone Fiji Network). The system then looks for password in the Message, if password is wrong it replies origin SMS indicating "Incorrect Password". If the password is matched then it search for command to be executed in the message, does the required task and then writes the feedback in form of message to the reply from the sender. The user can activate any appliances, Lights or sensor to check their status in the house via SMS using mobile phone. This password can be only change by the user from home. . Once the SMS is received, the microcontroller reads it and performs s the task directed by the user and informs the interrupt is generated, which instructs the microcontroller to stop what it is doing and take care of the higher priority task. Then the microprocessor writes the emergency message and sends it to user or relevant civil authorities. The message to be detected. After sending the message the microprocessor will jump back to the function it was doing before interrupt.

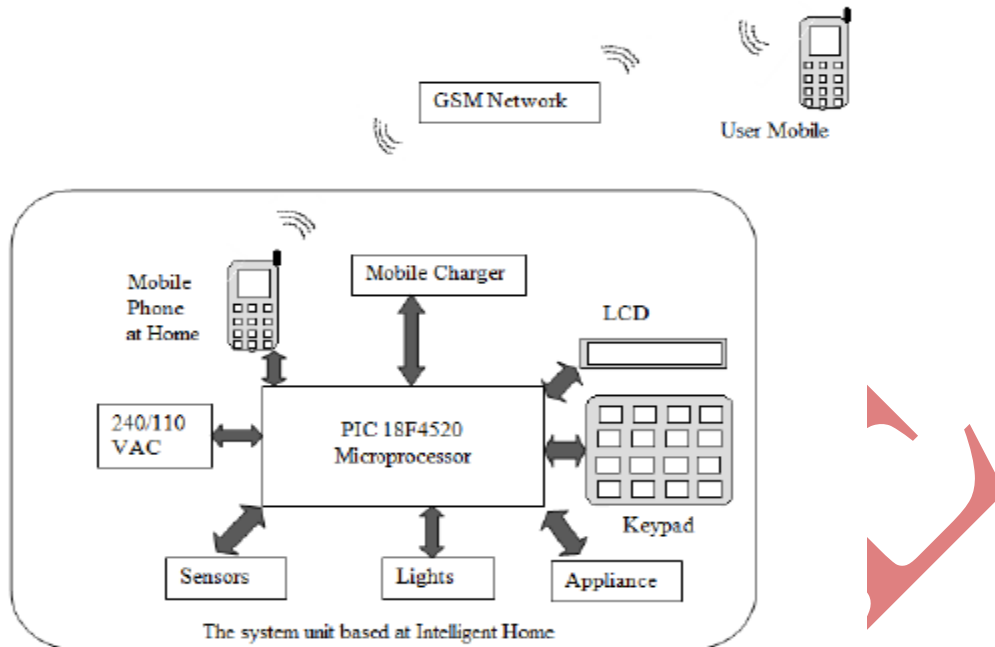

Fig. 1 Architecture of Intelligent Home system

The sensors are calibrated and programmed to read physical status of the intelligent home and give feedback. The smoke has to be turned on/off by the user. The motion detector is turned on/off by either SMS or manual switch located inside the home. The system uses the Light Dependent Resistor (LDR) which detects the status of the light and gives an analog output. Corresponding to the status of the lights the analog to digital conversion of the LDR output is done by the microcontroller programming. The AT commands are used to communicate with the mobile phone. AT is the abbreviation of "Attention". The interfacing between the mobile phone and the microprocessor is such that it can communicate with any mobile phone which can be connected serially to modems. The system based at home is generic, thus any mobile phone.

The user can easily change the emergency number on the unit at home. The C language program controlling the microprocessor uses 706.5 KB of RAM and 16711.68 KB ROM.

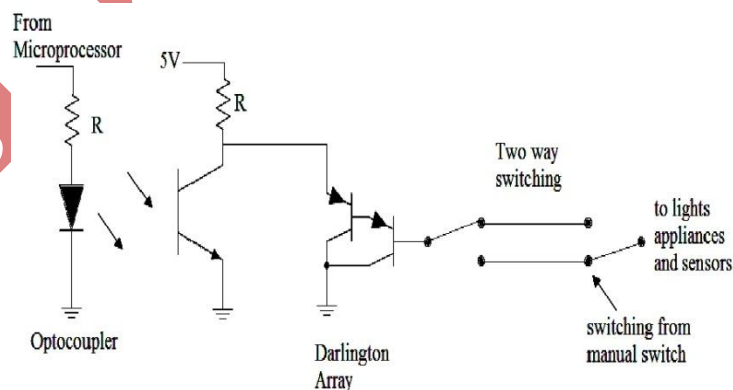
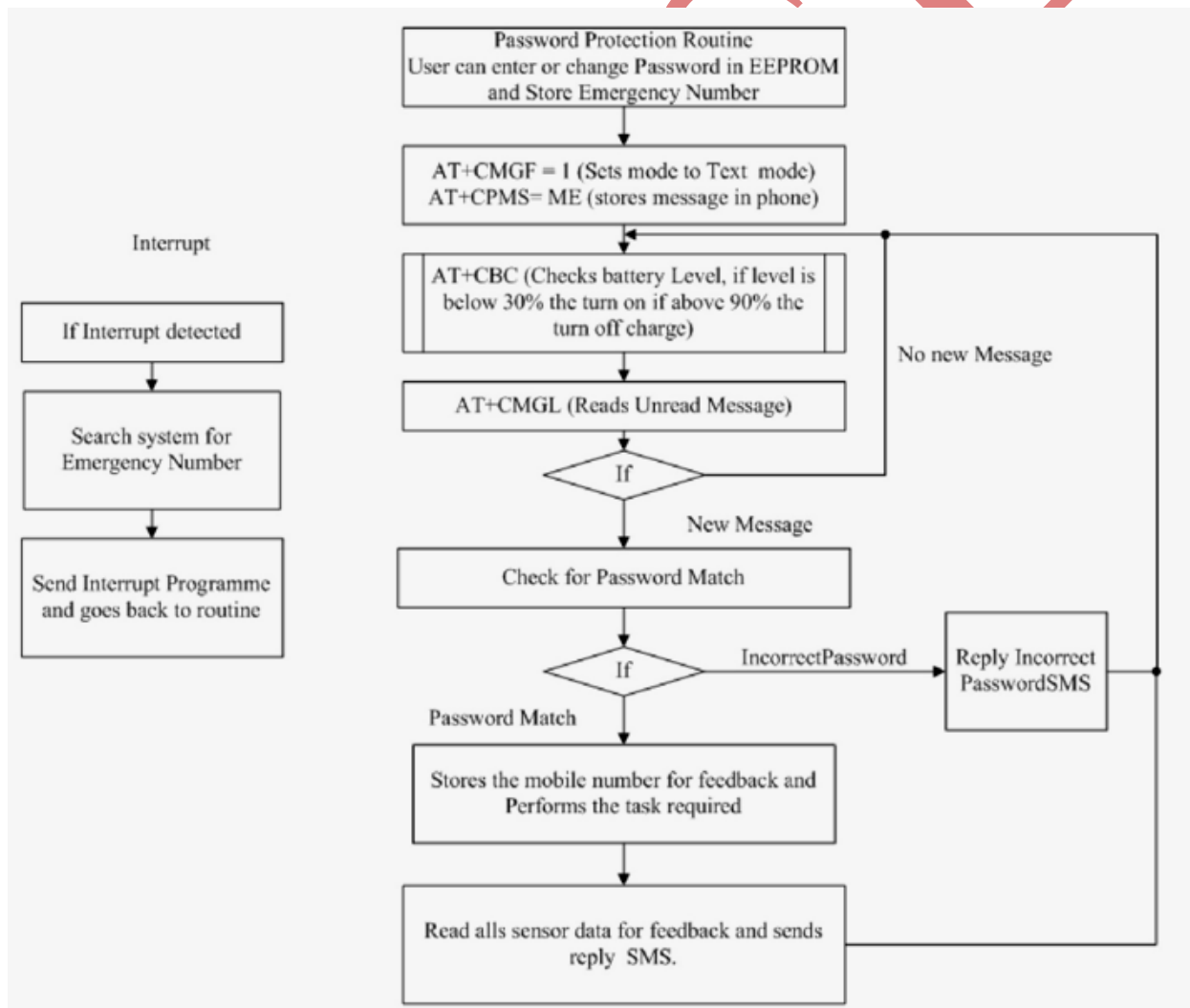

Fig. 3 Switching from low voltage to high voltage

The lights and other appliances controlled in the Intelligent home have two -way switching system. On e of the sides of the switching is manual and the other side s controlled by the microprocessor. Single Pole Double Throw (SPDT) relay is used to fulfill t he two way s switching from the microprocessor side. For the two way switching system, the light and appliances can be turned on or off from an y side of the switch as shown in Fig. 3.

The current from microcontroller is not enough to switch on the relay. Darlington array is used to boost the current supply t o the relays as shown in F ig. 3. Each channel for is rated at 500 mA and can withstand peak currents of 600 m A. Suppression diodes are included for inductive load driving and the inputs are pinned opposite to the outputs to simplify the board layout.

The microcontroller output is 5V which drives the relays to control the 240V AC. Whe n the relay s witches, the counter electromotive force is generated that can freeze the microcontroller. An Opto-coupler is used to solve the counter electromotive force problem by creating a wireless zone between the transmitter and the receiver sides in the Opto-coupler. Infrared transmitter and receiver have been used to design the Opto-coupler.



III EXPERIMENT ATION ON THE NETWORK

An experiment was design to obtain the time taken for Intelligent home to perform task given by the SMS and send feedback. In Fiji Islands there are two mobile networks. First a set of 25 SMS were sent from the user using Vodafone Fiji Network and Digicel Fiji Network to activate and deactivate the lights, switches and sensors at home. Fig. 3 shows that it takes an average of 20.16s for the user to send the message to the smart ho me to respond to the message sent b y the user and for the mobile phone based in the home to give feedback to the user between Vodafone Fijis to Vodafone Fiji network. Moreover, it takes an average of 20.56s for the same task using Digicel Fiji to Vodafone Fiji network. Hence SMS within the same network works faster. Another experiment was designed to get the time taken of 25 samples for the home to send an emergency SMS to the user and appropriate civil authority. Emergency situation in the design includes smoke detected at home and movement outside the home without the permission.

IV CONCLUSION

A cost effective and SMS operated home security system has been design need and tested with mobile network. The performance is commercially available. Sensors were first studied for their feasibility before installation in the intelligent home. The A T commands have been used that provide a flexible way to control and explore the services of the mobile. The communication with t he home is solely through SMS which has been tested with mobile networks and is expected to work on any mobile net work. The SMS should contain password anywhere in the message for the home to respond. In ca se of no password or incorrect password it will reply incorrect password message. In case of emergency the system will send an emergency SMS to the user and relevant civil authority in n average of 9.16s. This is one of the most effective and intelligent design to have at home for security and safety purposes. Moreover the same design can be used in business and other important places.

REFERENCES

- [1] Balasubramian, K. Cellatoglu, A. (2009). "Analysis of home control techniques employed in home automation and security system". IEEE transactions on consumer electronics.
- [2] Jin, M.H., Fu, C.J., Yu, C.H., Lai, H.R., Whei, M. (2008) "IBM3 Zigbee Positioning Method for Smart Home Applications", *International Journal of Smart Home*.
- [3] Yuksekkaya, B., Kayalar, A.A., Tonsun, M. B., Ozean, M.K., Alkar, A.Z. (2006) "A GSM, Int ernet and Speech Controlled Wireless interactive home automation system.
- [4] Zhao, Y., Ye, Z.(2008) "A Low Cost GSM/GP RS Based Wireless Home Security System", *IEEE Trans. Consumer Electronics*.
- [5] Karim, J., Amat, W.M.A.B. W., Razak, A.H.A. (2009) "Car Ignition System via Mobile Phone", *International Conference on Future Computer and Communication*
- [6] Ur-Rahman, M.W., Ahmed, M.T., Khan, T.H., Kabir, S.M.L . (2009) "Design of an Intelligent SMS based Remote Metering System", *IEEE Conference Information and Automation*.